

SECTION **HA**

CONTENTS

PRECAUTIONS AND PREPARATION2	Main Power Supply and Ground Circuit Check60
Supplemental Restraint System (SRS) "AIR BAG"2	Diagnostic Procedure 161
Precautions for Working with HFC-134a (R-134a)2	Diagnostic Procedure 262
General Refrigerant Precautions2	Diagnostic Procedure 363
Precautions for Refrigerant Connection3	Diagnostic Procedure 464
Precautions for Servicing Compressor.....6	Diagnostic Procedure 565
Special Service Tools6	Diagnostic Procedure 666
HFC-134a (R-134a) Service Tools and Equipment.....7	Diagnostic Procedure 767
Precautions for Service Equipment.....9	Diagnostic Procedure 869
DESCRIPTION11	Diagnostic Procedure 971
Refrigeration Cycle11	Electrical Components Inspection73
V-6 Variable Displacement Compressor.....12	Control Linkage Adjustment.....74
Component Layout16	SYSTEM DESCRIPTION76
Discharge Air Flow.....17	Overview of Control System.....76
Introduction18	Control System Input Components77
Features.....18	Control System Automatic Amplifier (Auto amp.)79
Control Operation21	Control System Output Components.....80
TROUBLE DIAGNOSES23	SERVICE PROCEDURES88
How to Perform Trouble Diagnoses for Quick and Accurate Repair.....23	HFC-134a (R-134a) Service Procedure88
Operational Check.....24	Maintenance of Lubricant Quantity in Compressor90
Symptom Chart.....28	Refrigerant Lines92
Self-diagnosis30	Checking Refrigerant Leaks93
Preliminary Check.....40	Compressor Mounting96
Performance Test Diagnoses48	Belt Tension96
Performance Chart50	Fast Idle Control Device (FICD)96
Trouble Diagnoses for Abnormal Pressure51	Compressor97
Harness Layout.....54	Compressor Clutch97
Circuit Diagram56	SERVICE DATA AND SPECIFICATIONS (SDS)101
Wiring Diagram — A/C, A —57	General Specifications.....101
	Inspection and Adjustment101

When you read wiring diagrams:

- Read GI section, "HOW TO READ WIRING DIAGRAMS".
- See EL section, "POWER SUPPLY ROUTING" for power distribution circuit.

When you perform trouble diagnoses, read GI section, "HOW TO FOLLOW FLOW CHART IN TROUBLE DIAGNOSES" and "HOW TO PERFORM EFFICIENT DIAGNOSIS FOR AN ELECTRICAL INCIDENT".

GI
MA
EM
LC
EC
FE
CL
MT
AT
FA
RA
BR
ST
RS
BT
HA
EL
IDX

PRECAUTIONS AND PREPARATION

Supplemental Restraint System (SRS) "AIR BAG"

The Supplemental Restraint System "AIR BAG", used along with a seat belt, helps to reduce the risk or severity of injury to the driver and front passenger in a frontal collision. The Supplemental Restraint System consists of air bag modules (located in the center of the steering wheel and on the instrument panel on the passenger side), a diagnosis sensor unit, warning lamp, wiring harness and spiral cable. If the vehicle is equipped with side air bag as the Supplemental Restraint System, the supplemental side air bag used along with the seat belt helps to reduce the risk or severity of injury to the driver and front passenger in a side collision. The supplemental side air bag consists of air bag modules (located in the outer side of front seats), satellite sensor, diagnosis sensor unit (which is one of components of supplemental air bags for a frontal collision), wiring harness, warning lamp (which is one of components of supplemental air bags for a frontal collision). Information necessary to service the system safely is included in the **RS section** in this Service Manual.

WARNING:

- To avoid rendering the SRS inoperative, which could increase the risk of personal injury or death in the event of a collision which would result in air bag inflation, all maintenance must be performed by an authorized INFINITI dealer.
- Improper maintenance, including incorrect removal and installation of the SRS, can lead to personal injury caused by unintentional activation of the system.
- Do not use electrical test equipment on any circuit related to the SRS unless instructed to in this Service Manual. SRS wiring harnesses can be identified with yellow harness protector or yellow insulation tape before the harness connectors.

Precautions for Working with HFC-134a (R-134a)

WARNING:

- CFC-12 (R-12) refrigerant and HFC-134a (R-134a) refrigerant are not compatible. These refrigerants must never be mixed, even in the smallest amounts. If the refrigerants are mixed, compressor failure is likely to occur.
- Use only specified lubricant for the HFC-134a (R-134a) A/C system and HFC-134a (R-134a) components. If lubricant other than that specified is used, compressor failure is likely to occur.
- The specified HFC-134a (R-134a) lubricant rapidly absorbs moisture from the atmosphere. The following handling precautions must be observed:
 - a: When removing refrigerant components from a vehicle, immediately cap (seal) the component to minimize the entry of moisture from the atmosphere.
 - b: When installing refrigerant components to a vehicle, do not remove the caps (unseal) until just before connecting the components. Connect all refrigerant loop components as quickly as possible to minimize the entry of moisture into system.
 - c: Only use the specified lubricant from a sealed container. Immediately reseal containers of lubricant. Without proper sealing, lubricant will become moisture saturated and should not be used.
 - d: Avoid breathing A/C refrigerant and lubricant vapor or mist. Exposure may irritate eyes, nose and throat. Remove R-134a from the A/C system, using certified service equipment meeting requirements of SAE J2210 (R-134a recycling equipment), or J2209 (R-134a recovery equipment). If accidental system discharge occurs, ventilate work area before resuming service. Additional health and safety information may be obtained from refrigerant and lubricant manufacturers.
 - e: Do not allow lubricant (Nissan A/C System Oil Type S) to come in contact with styrofoam parts. Damage may result.

General Refrigerant Precautions

WARNING:

- Do not release refrigerant into the air. Use approved recovery/recycling equipment to capture the refrigerant every time an air conditioning system is discharged.
- Always wear eye and hand protection (goggles and gloves) when working with any refrigerant or air conditioning system.
- Do not store or heat refrigerant containers above 52°C (125°F).

PRECAUTIONS AND PREPARATION

General Refrigerant Precautions (Cont'd)

- Do not heat a refrigerant container with an open flame; if container warming is required, place the bottom of the container in a warm pail of water.
- Do not intentionally drop, puncture, or incinerate refrigerant containers.
- Keep refrigerant away from open flames: poisonous gas will be produced if refrigerant burns.
- Refrigerant will displace oxygen, therefore be certain to work in well ventilated areas to prevent suffocation.
- Do not introduce compressed air to any refrigerant container or refrigerant component.

Precautions for Refrigerant Connection

A new type refrigerant connection has been introduced to all refrigerant lines except the following portion.

- Expansion valve to cooling unit

FEATURES OF NEW TYPE REFRIGERANT CONNECTION

- The O-ring has been relocated. It has also been provided with a groove for proper installation. This eliminates the chance of the O-ring being caught in, or damaged by, the mating part. The sealing direction of the O-ring is now set vertically in relation to the contacting surface of the mating part to improve sealing characteristics.
- The reaction force of the O-ring will not occur in the direction that causes the joint to pull out, thereby facilitating piping connections.

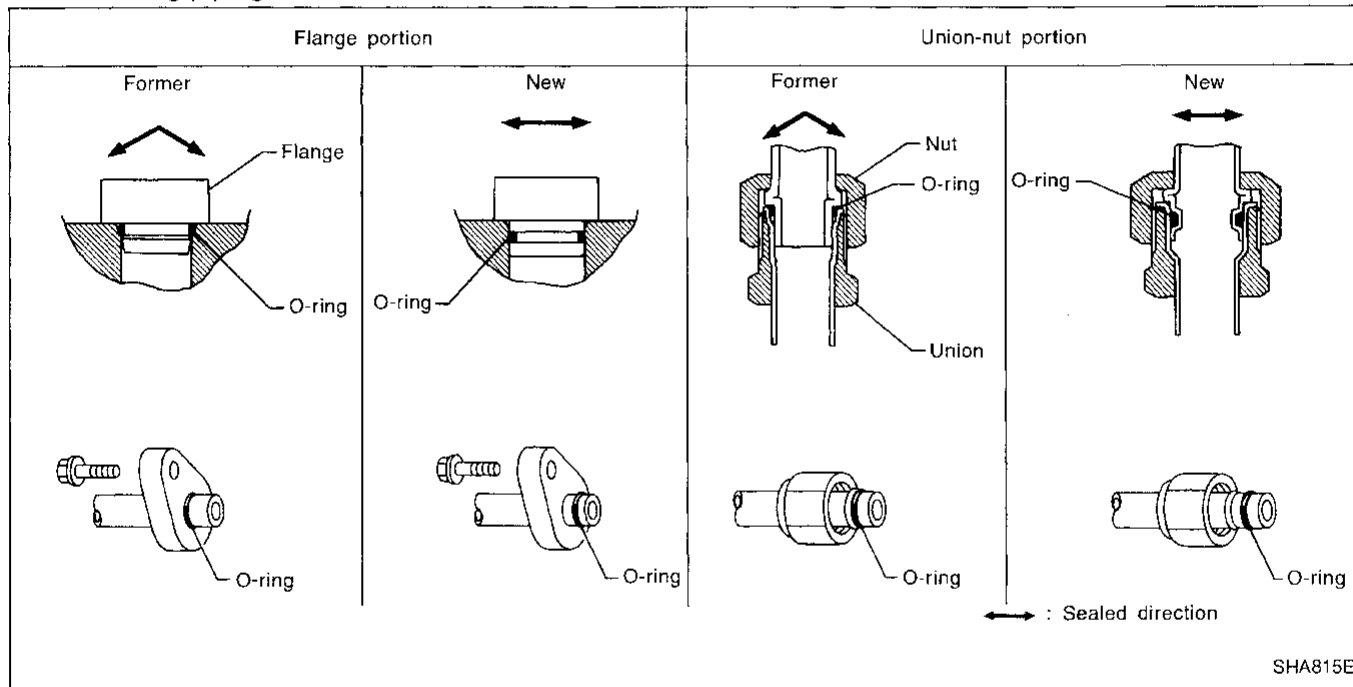

PRECAUTIONS AND PREPARATION

Precautions for Refrigerant Connection (Cont'd) O-RING AND REFRIGERANT CONNECTION

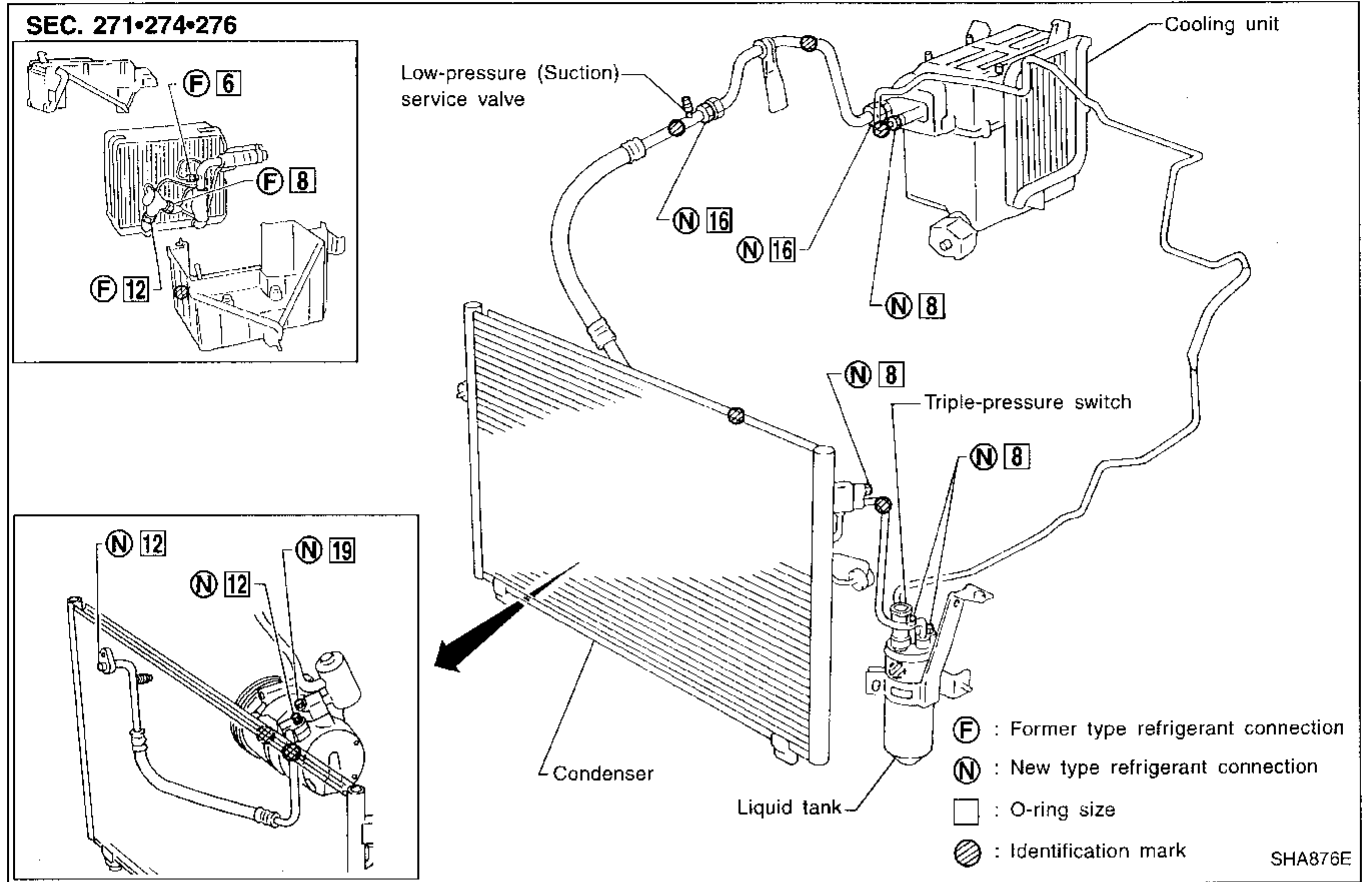

CAUTION:

The new and former refrigerant connections use different O-ring configurations. Do not confuse O-rings since they are not interchangeable. If a wrong O-ring is installed, refrigerant will leak at, or around, the connection.

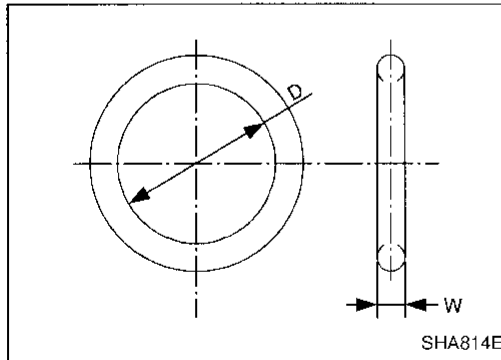

O-ring part numbers and specifications

Connection type	O-ring size	Part number	D mm (in)	W mm (in)
Former	6	92472 N8200	4.5 (0.177)	1.40 (0.0551)
New	8	92471 N8210	6.8 (0.268)	1.85 (0.0728)
Former	8	92470 N8200	6.07 (0.2390)	1.78 (0.0701)
New	12	92472 N8210	10.9 (0.429)	2.43 (0.0957)
Former	12	92471 N8200	10.8 (0.425)	1.78 (0.0701)
New	16	92473 N8210	13.6 (0.535)	2.43 (0.0957)
New	16	92474 N8210	16.5 (0.650)	2.43 (0.0957)
Former	19	92477 N8200	17.12 (0.6740)	1.78 (0.0701)

In accordance with the adoption of the new type refrigerant connection, the following components are not interchangeable between the former year model (1996 year model) and the current year model (1998 year model).

- Compressor
- Condenser
- Cooling unit
- Liquid tank
- Tubes and flexible hoses

PRECAUTIONS AND PREPARATION

Precautions for Refrigerant Connection (Cont'd)

WARNING:

Make sure all refrigerant is discharged into the recycling equipment and the pressure in the system is less than atmospheric pressure. Then gradually loosen the discharge side hose fitting and remove it.

CAUTION:

When replacing or cleaning refrigerant cycle components, observe the following.

- When the compressor is removed, store it in the same position as it is when mounted on the car. Failure to do so will cause lubricant to enter the low pressure chamber.
- When connecting tubes, always use a torque wrench and a back-up wrench.
- After disconnecting tubes, immediately plug all openings to prevent entry of dirt and moisture.
- When installing an air conditioner in the vehicle, connect the pipes as the final stage of the operation. Do not remove the seal caps of pipes and other components until just before required for connection.
- Allow components stored in cool areas to warm to working area temperature before removing seal caps. This prevents condensation from forming inside A/C components.
- Thoroughly remove moisture from the refrigeration system before charging the refrigerant.
- Always replace used O-rings.
- When connecting tube, apply lubricant to circle of the O-rings shown in illustration. Be careful not to apply lubricant to threaded portion.

Lubricant name: Nissan A/C System Oil Type S

Part number: KLH00-PAGS0

- O-ring must be closely attached to dented portion of tube.
- When replacing the O-ring, be careful not to damage O-ring and tube.
- Connect tube until you hear it click, then tighten the nut or bolt by hand until snug. Make sure that the O-ring is installed to tube correctly.
- After connecting line, conduct leak test and make sure that there is no leakage from connections. When the gas leaking point is found, disconnect that line and replace the O-ring. Then tighten connections of seal seat to the specified torque.

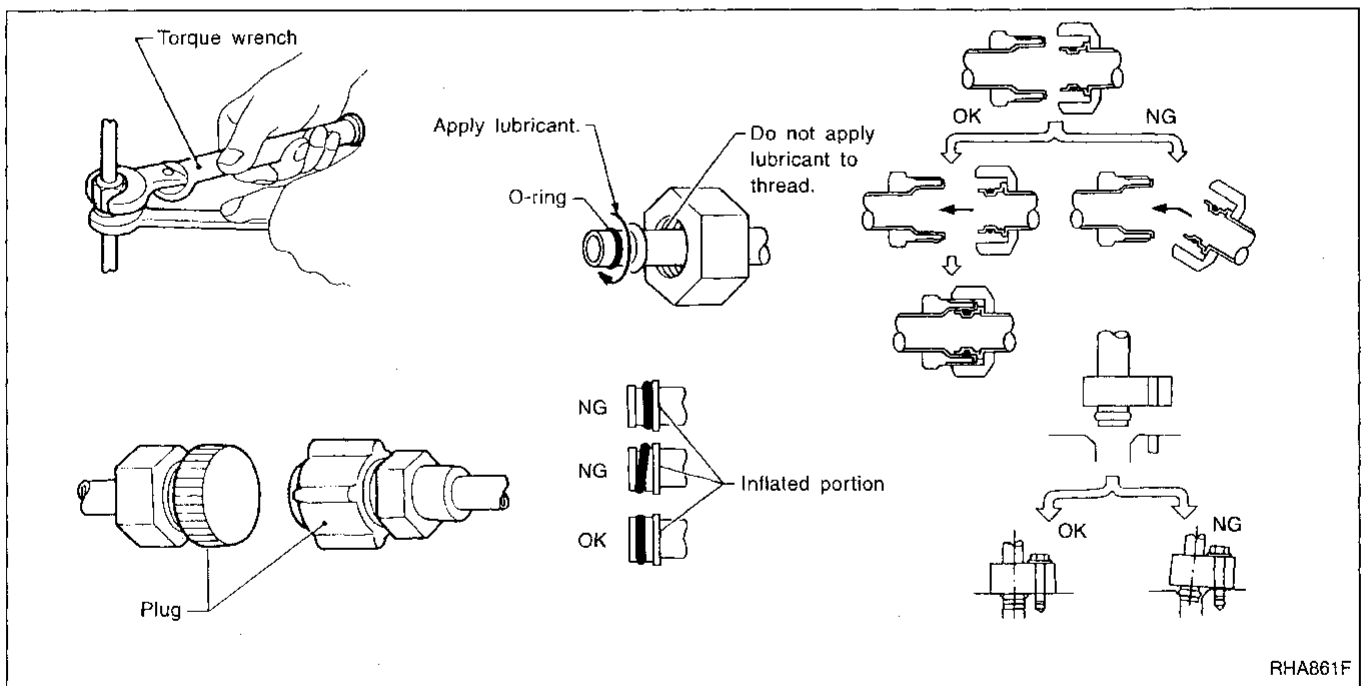



PRECAUTIONS AND PREPARATION

Precautions for Servicing Compressor

- Plug all openings to prevent moisture and foreign matter from entering.
- When the compressor is removed, store it in the same position as it is when mounted on the car.
- When replacing or repairing compressor, follow "Maintenance of Lubricant Quantity in Compressor" exactly. Refer to HA-90.
- Keep friction surfaces between clutch and pulley clean. If the surface is contaminated, with lubricant, wipe it off by using a clean waste cloth moistened with thinner.
- After compressor service operation, turn the compressor shaft by hand more than five turns in both directions. This will equally distribute lubricant inside the compressor. After the compressor is installed, let the engine idle and operate the compressor for one hour.
- After replacing the compressor magnet clutch, apply voltage to the new one and check for normal operation.

Special Service Tools

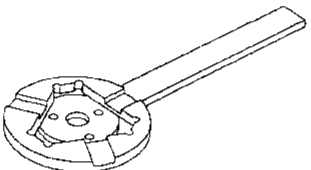
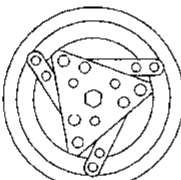
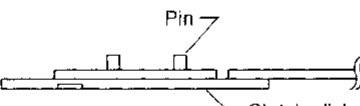
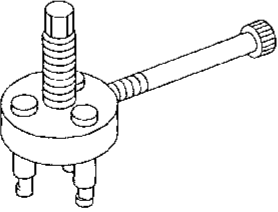
The actual shapes of Kent-Moore tools may differ from those of special service tools illustrated here.

Tool number (Kent-Moore No.) Tool name	Description
KV99106100 (J-41260) Clutch disc wrench	Removing center bolt  NT232  When replacing the magnet clutch in the above compressor, use a clutch disc wrench with the pin side on the clutch disc to remove it.  NT378
KV99232340 (J-38874) or KV992T0001 (—) Clutch disc puller	Removing clutch disc  NT376
KV99106200 (J-41261) Pulley installer	Installing pulley  NT235

PRECAUTIONS AND PREPARATION

HFC-134a (R-134a) Service Tools and Equipment

Never mix HFC-134a refrigerant and/or its specified lubricant with CFC-12 (R-12) refrigerant and/or its lubricant.

Separate and non-interchangeable service equipment must be used for handling each type of refrigerant/lubricant.

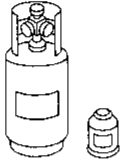
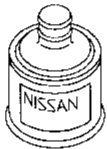
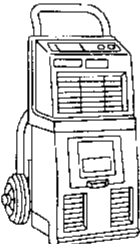
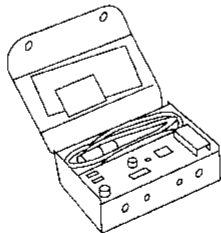
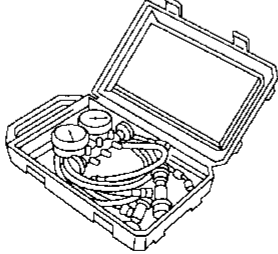

Refrigerant container fittings, service hose fittings and service equipment fittings (equipment which handles refrigerant and/or lubricant) are different between CFC-12 (R-12) and HFC-134a (R-134a). This is to avoid mixed use of the refrigerants/lubricant.

Adapters that convert one size fitting to another must never be used: refrigerant/lubricant contamination will occur and compressor failure will result.

Tool number (Kent-Moore No.) Tool name	Description	Note
HFC-134a (R-134a) refrigerant	 NT196	Container color: Light blue Container marking: HFC-134a (R-134a) Fitting size: Thread size • large container 1/2"-16 ACME
KLH00-PAGS0 (—) Nissan A/C System Oil Type S	 NT197	Type: Poly alkylene glycol oil (PAG), type S Application: HFC-134a (R-134a) swash plate (piston) compressors (Nissan only) Lubricity: 40 ml (1.4 US fl oz, 1.4 Imp fl oz)
(J-39500-INF) Recovery/Recycling Recharging equipment (ACR4)	 NT195	Function: Refrigerant Recovery and Recycling and Recharging
(J-39400) Electrical leak detector	 NT198	Power supply: • DC 12V (Cigarette lighter)
(J-39183) Manifold gauge set (with hoses and couplers)	 NT199	Identification: • The gauge face indicates R-134a. Fitting size: Thread size • 1/2"-16 ACME

PRECAUTIONS AND PREPARATION

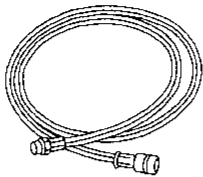
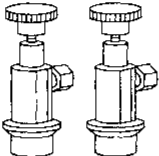
HFC-134a (R-134a) Service Tools and Equipment (Cont'd)

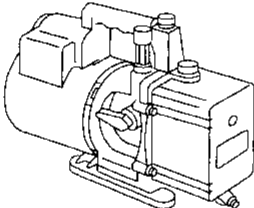
Tool number (Kent-Moore No.) Tool name	Description	Note
Service hoses <ul style="list-style-type: none"> ● High side hose (J-39501-72) ● Low side hose (J-39502-72) ● Utility hose (J-39476-72) 	 <p style="text-align: center;">NT201</p>	Hose color: <ul style="list-style-type: none"> ● Low hose: Blue with black stripe ● High hose: Red with black stripe ● Utility hose: Yellow with black stripe or green with black stripe Hose fitting to gauge: <ul style="list-style-type: none"> ● 1/2"-16 ACME
Service couplers <ul style="list-style-type: none"> ● High side coupler (J-39500-20) ● Low side coupler (J-39500-24) 	 <p style="text-align: center;">NT202</p>	Hose fitting to service hose: <ul style="list-style-type: none"> ● M14 x 1.5 fitting is optional or permanently attached.
(J-39650) Refrigerant weight scale	 <p style="text-align: center;">NT200</p>	For measuring of refrigerant Fitting size: Thread size <ul style="list-style-type: none"> ● 1/2"-16 ACME
(J-39649) Vacuum pump (Including the isolator valve)	 <p style="text-align: center;">NT203</p>	Capacity: <ul style="list-style-type: none"> ● Air displacement: 4 CFM ● Micron rating: 20 microns ● Oil capacity: 482 g (17 oz) Fitting size: Thread size <ul style="list-style-type: none"> ● 1/2"-16 ACME

PRECAUTIONS AND PREPARATION

Precautions for Service Equipment

RECOVERY/RECYCLING EQUIPMENT

Follow the manufacturer's instructions for machine operation and machine maintenance. Never introduce any refrigerant other than that specified into the machine.

ELECTRONIC LEAK DETECTOR

Follow the manufacture's instructions for tester operation and tester maintenance.

VACUUM PUMP

The lubricant contained inside the vacuum pump is not compatible with the specified lubricant for HFC-134a (R-134a) A/C systems. The vent side of the vacuum pump is exposed to atmospheric pressure. So the vacuum pump lubricant may migrate out of the pump into the service hose. This is possible when the pump is switched off after evacuation (vacuuming) and hose is connected to it.

To prevent this migration, use a manual valve situated near the hose-to-pump connection, as follows.

- Usually vacuum pumps have a manual isolator valve as part of the pump. Close this valve to isolate the service hose from the pump.
- For pumps without an isolator, use a hose equipped with a manual shut-off valve near the pump end. Close the valve to isolate the hose from the pump.
- If the hose has an automatic shut off valve, disconnect the hose from the pump: as long as the hose is connected, the valve is open and lubricating oil may migrate.

Some one-way valves open when vacuum is applied and close under a no vacuum condition. Such valves may restrict the pump's ability to pull a deep vacuum and are not recommended.

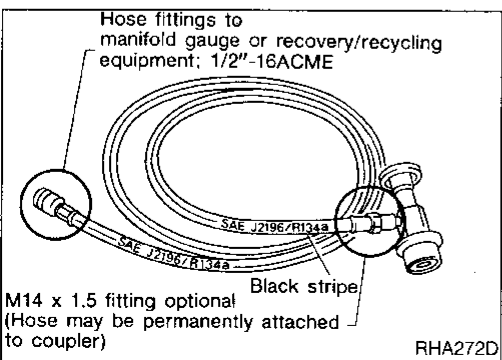
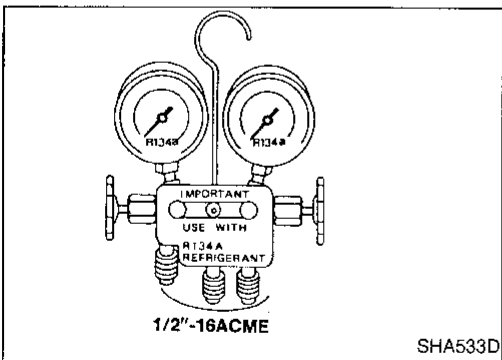
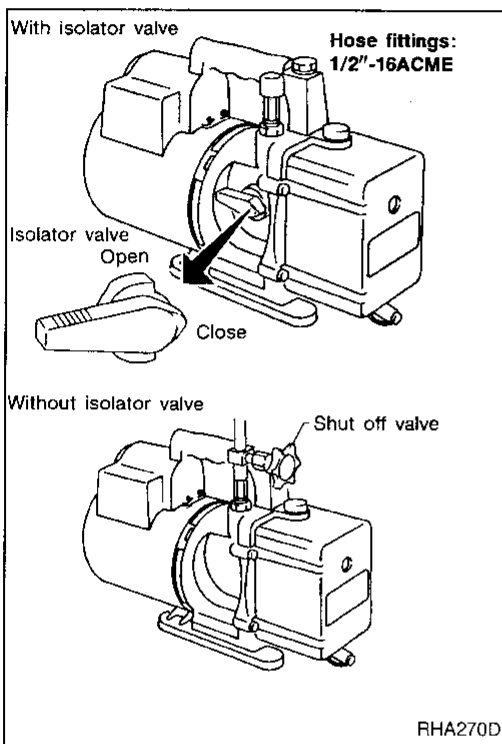

MANIFOLD GAUGE SET

Be certain that the gauge face indicates R-134a or 134a. Make sure the gauge set has 1/2"-16 ACME threaded connections for service hoses. Confirm the set has been used only with refrigerant HFC-134a (R-134a) along with specified lubricant.

SERVICE HOSES

Be certain that the service hoses display the markings described (colored hose with black stripe). All hoses must include positive shut off devices (either manual or automatic) near the end of the hoses opposite the manifold gauge.

GI

MA

EM

LC

EC

FE

CL

MT

AT

FA

RA

BR

ST

RS

BT

HA

EL

IDX

PRECAUTIONS AND PREPARATION

Precautions for Service Equipment (Cont'd)

SERVICE COUPLERS

Never attempt to connect HFC-134a (R-134a) service couplers to an CFC-12 (R-12) A/C system. The HFC-134a (R-134a) couplers will not properly connect to the CFC-12 (R-12) system. However, if an improper connection is attempted, discharging and contamination may occur.

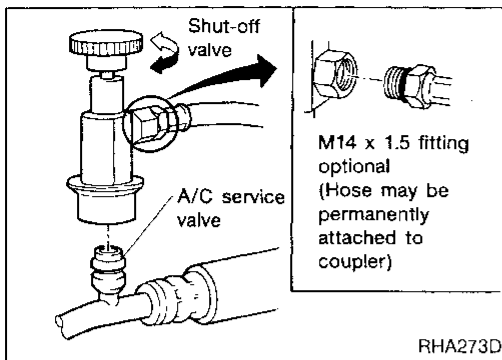

Shut off valve rotation	A/C service valve
Clockwise	Open
Counterclockwise	Close

REFRIGERANT WEIGHT SCALE

Verify that no refrigerant other than HFC-134a (R-134a) and specified lubricants have been used with the scale. If the scale controls refrigerant flow electronically, the hose fitting must be 1/2"-16 ACME.

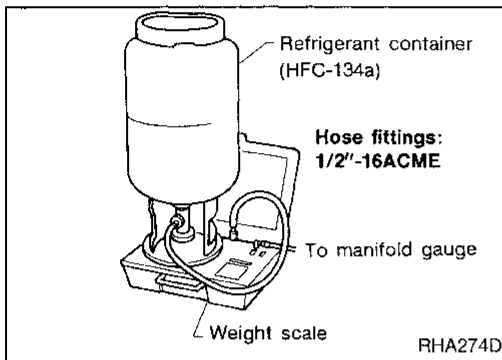

CHARGING CYLINDER

Using a charging cylinder is not recommended. Refrigerant may be vented into air from cylinder's top valve when filling the cylinder with refrigerant. Also, the accuracy of the cylinder is generally less than that of an electronic scale or of quality recycle/recharge equipment.

Refrigeration Cycle

REFRIGERANT FLOW

The refrigerant flow is in the standard pattern. Refrigerant flows through the compressor, condenser, liquid tank, evaporator, and back to the compressor.

The refrigerant evaporation through the evaporator coil is controlled by an externally equalized expansion valve, located inside the evaporator case.

FREEZE PROTECTION

Under normal operating conditions, when the AUTO is switched on, the compressor runs continuously, and the evaporator pressure, and therefore temperature, is controlled by the V-6 variable displacement compressor to prevent freeze up.

REFRIGERANT SYSTEM PROTECTION

Triple-pressure switch

The triple-pressure switch is located on the liquid tank. If the system pressure rises or falls out of specifications, the switch opens to interrupt compressor clutch operation. Triple-pressure switch closes to turn on the cooling fan to reduce system pressure.

Pressure relief valve

The refrigerant system is protected by a pressure relief valve. The valve is located on the bottom of the compressor. When refrigerant system pressure increases abnormally [over 3,727 kPa (38 kg/cm², 540 psi)], the relief valve's port opens. The valve then releases refrigerant into the atmosphere.

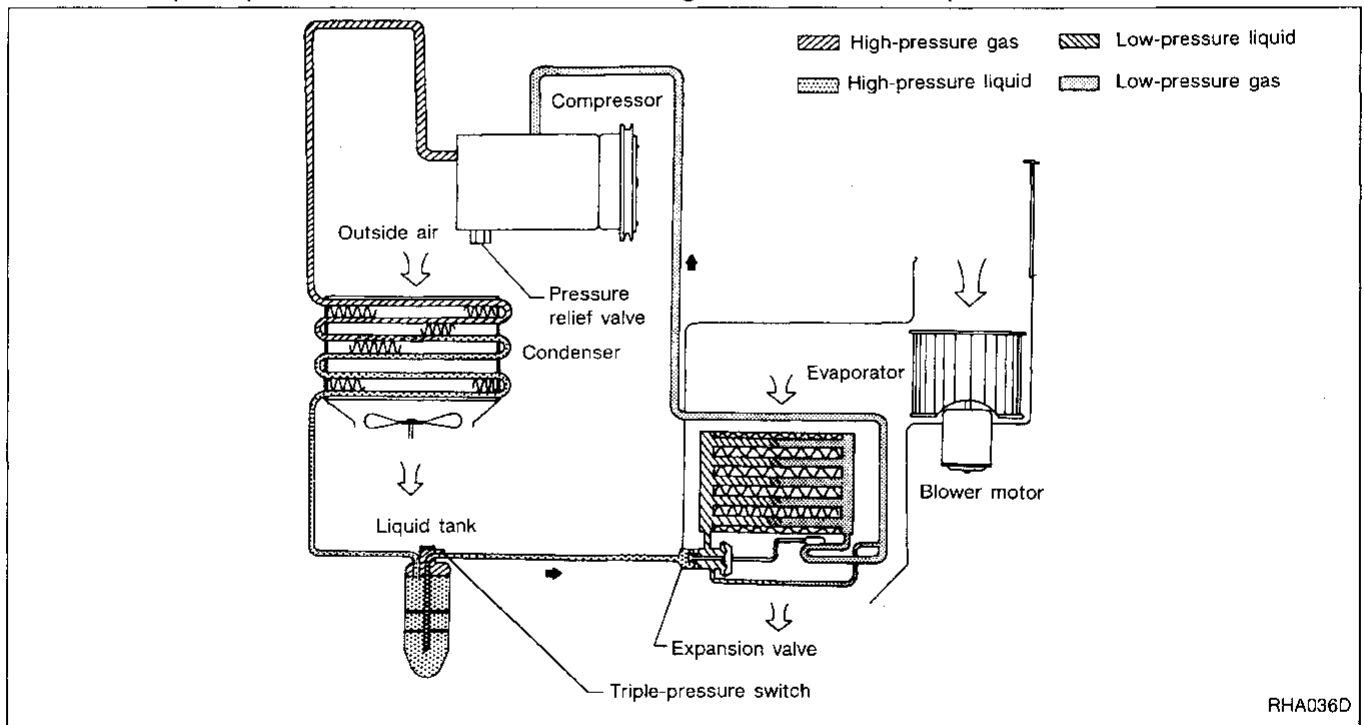

V-6 Variable Displacement Compressor

GENERAL INFORMATION

1. The V-6 variable compressor differs from previous units. The vent temperatures of the V-6 variable compressor do not drop too far below 5°C (41°F) when:
 - evaporator intake air temperature is less than 20°C (68°F)
 - engine is running at speeds less than 1,500 rpm.This is because the V-6 compressor provides a means of “capacity” control.
2. The V-6 variable compressor provides refrigerant control under varying conditions. During cold winters, it may not produce high refrigerant pressure discharge (compared to previous units) when used with air conditioning systems.
3. A “clanking” sound may occasionally be heard during refrigerant charge. The sound indicates that the tilt angle of the swash plate has changed and is not a problem.
4. For air conditioning systems with the V-6 compressor, the clutch remains engaged unless: the system main switch, fan switch or ignition switch is turned OFF. When ambient (outside) temperatures are low or when the amount of refrigerant is insufficient, the clutch is disengaged to protect the compressor.
5. A constant range of suction pressure is maintained when engine speed is greater than a certain value. It normally ranges from 147 to 177 kPa (1.5 to 1.8 kg/cm², 21 to 26 psi) under varying conditions. In previous compressors, however, suction pressure was reduced with increases in engine speed.

DESCRIPTION

V-6 Variable Displacement Compressor (Cont'd)

DESCRIPTION

General

The variable compressor is basically a swash plate type that changes piston stroke in response to the required cooling capacity.

The tilt of the swash plate allows the piston's stroke to change so that refrigerant discharge can be continuously changed from 10.5 to 184 cm³ (0.641 to 11.228 cu in).

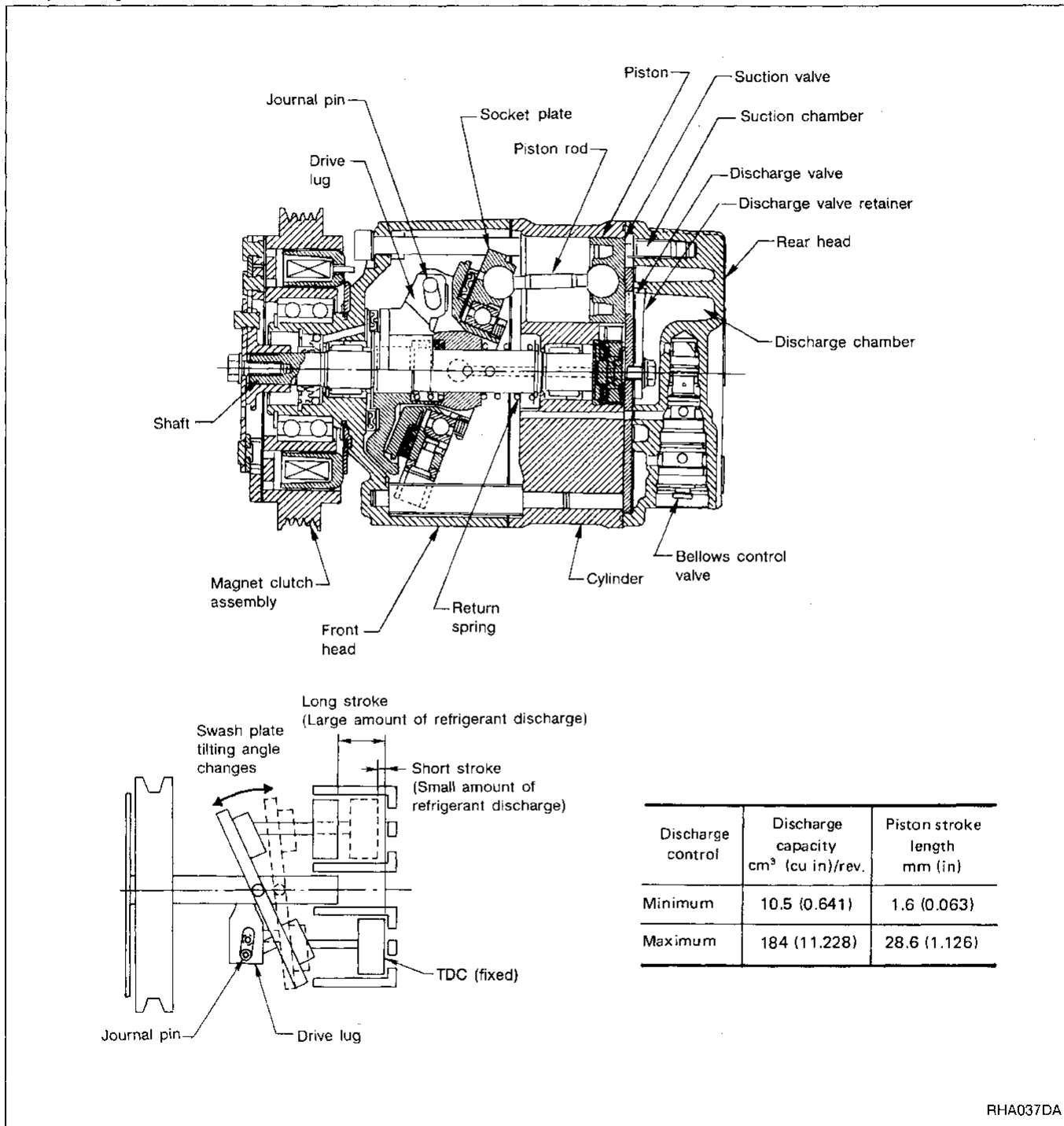

RHA037DA

GI
MA
EM
LC
EC
FE
CL
MT
AT
FA
RA
BR
ST
RS
BT
HA
EL
IDX

DESCRIPTION

V-6 Variable Displacement Compressor (Cont'd)

Operation

1. Operation control valve

Operation control valve is located in the suction port (low-pressure) side, and opens or closes in response to changes in refrigerant suction pressure.

Operation of the valve controls the internal pressure of the crankcase.

The angle of the swash plate is controlled between the crankcase's internal pressure and the piston cylinder pressure.

2. Maximum cooling

Refrigerant pressure on the low-pressure side increases with an increase in heat loads.

When this occurs, the control valve's bellows compress to open the low-pressure side valve and close the high-pressure side valve.

This causes the following pressure changes:

- the crankcase's internal pressure to equal the pressure on the low-pressure side;
- the cylinder's internal pressure to be greater than the crankcase's internal pressure.

Under this condition, the swash plate is set to the maximum stroke position.

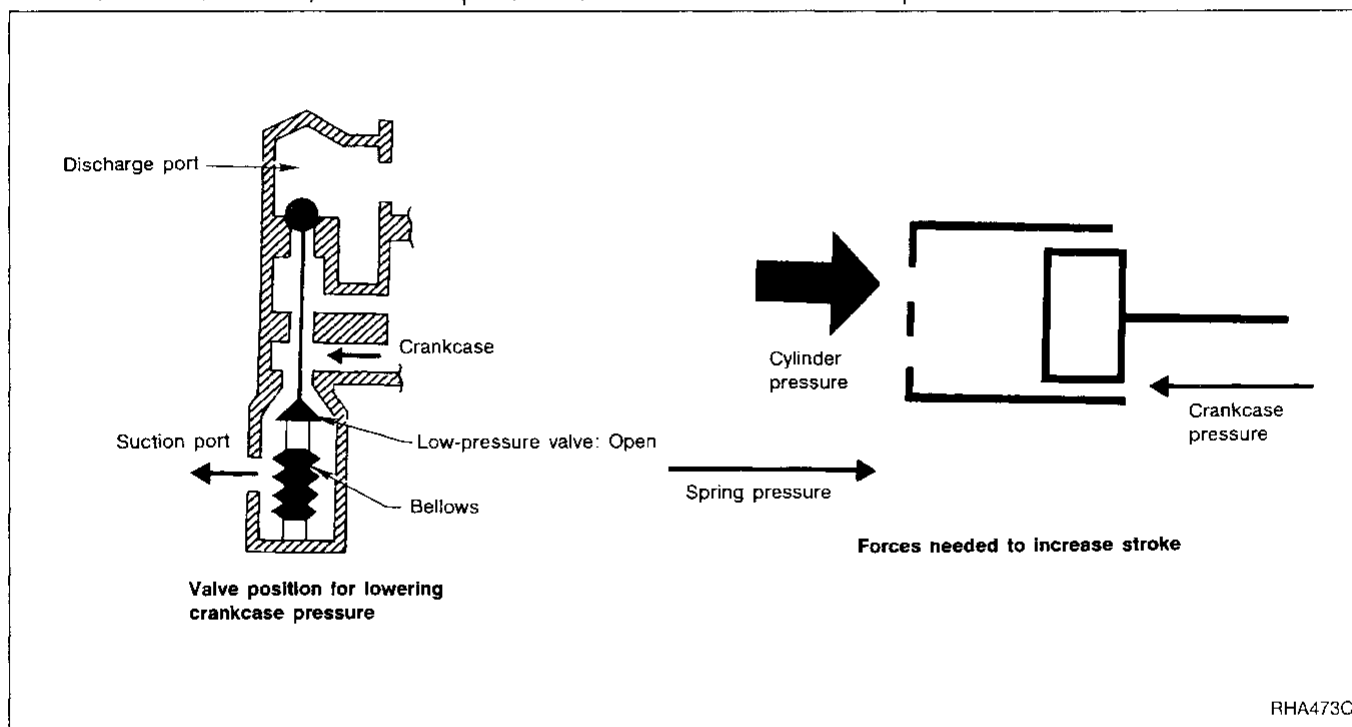

DESCRIPTION

V-6 Variable Displacement Compressor (Cont'd)

3. Capacity control

- Refrigerant pressure on suction side is low during high speed driving or when ambient or interior temperature is low.
- The bellows expands when refrigerant pressure on the suction pressure side drops below approximately 177 kPa (1.8 kg/cm², 26 psi).

Since suction pressure is low, it makes the suction port close and the discharge port open. Thus, crankcase pressure becomes high as high pressure enters the crankcase.

- The force acts around the journal pin near the swash plate, and is generated by the pressure difference before and behind the piston.

The drive lug and journal pin are located where the piston generates the highest pressure. Piston pressure is between suction pressure P_s and discharge pressure P_d , which is near suction pressure P_s . If crankcase pressure P_c rises due to capacity control, the force around the journal pin makes the swash plate angle decrease and also the piston stroke decrease. In other words, crankcase pressure increase triggers pressure difference between the piston and the crankcase. The pressure difference changes the angle of the swash plate.

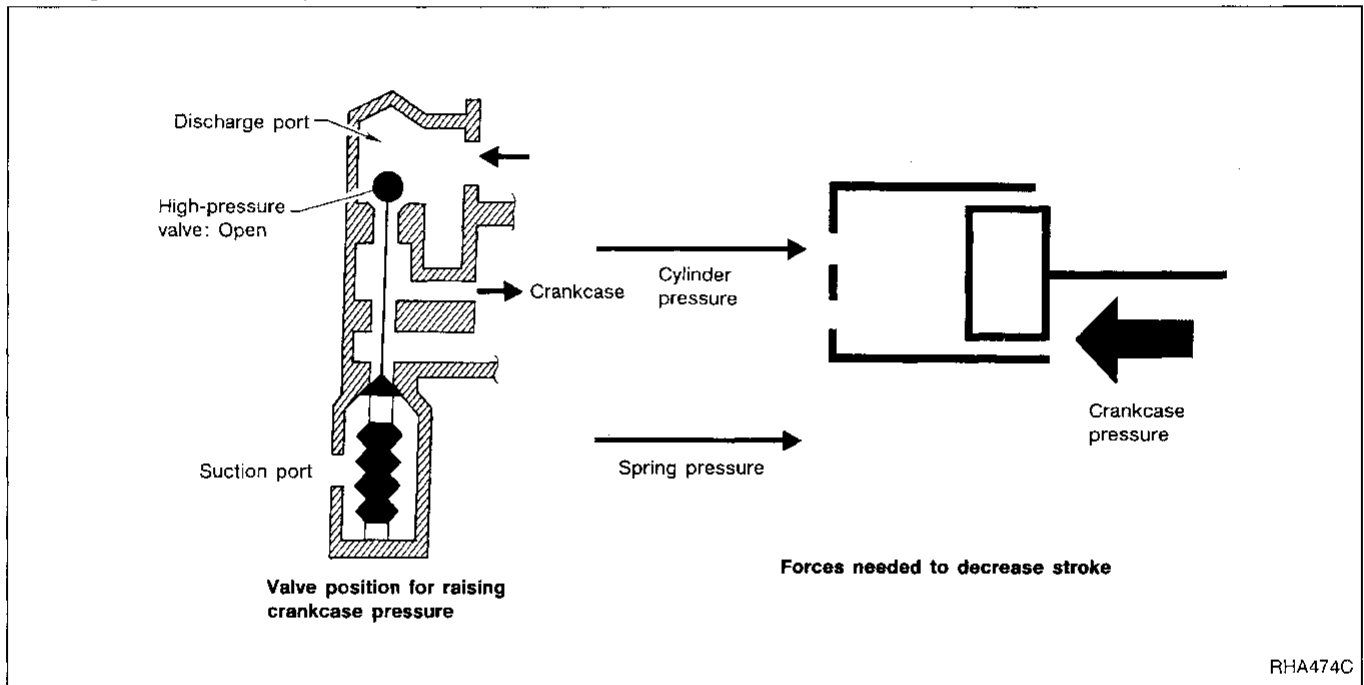

DESCRIPTION

Component Layout

SEC. 270-271-273

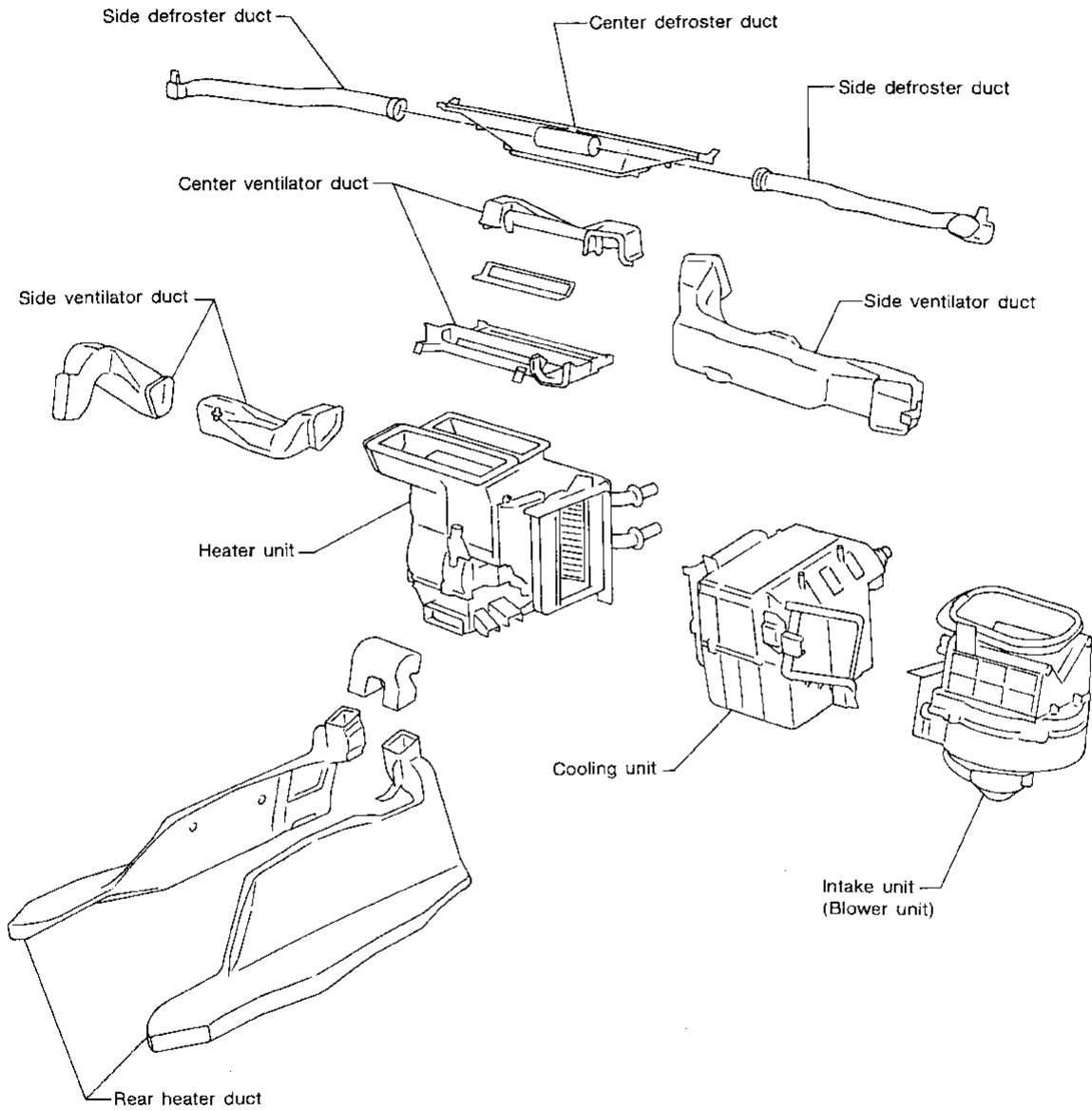

Discharge Air Flow

Air outlets

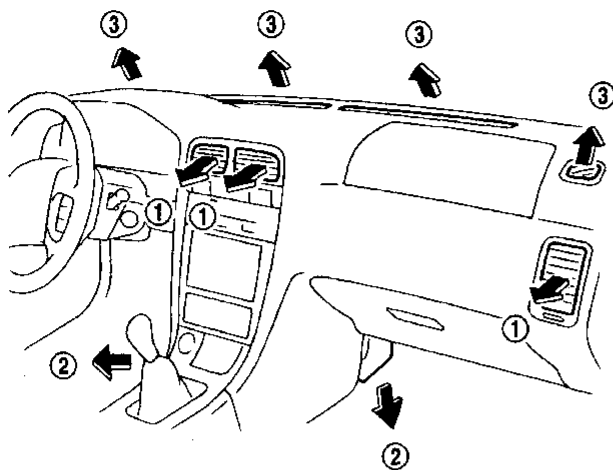

Foot

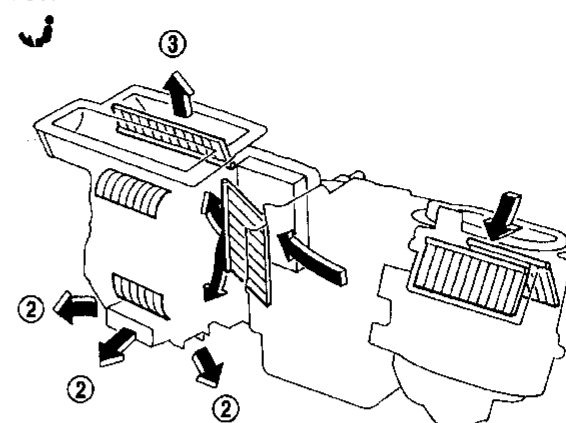

Face

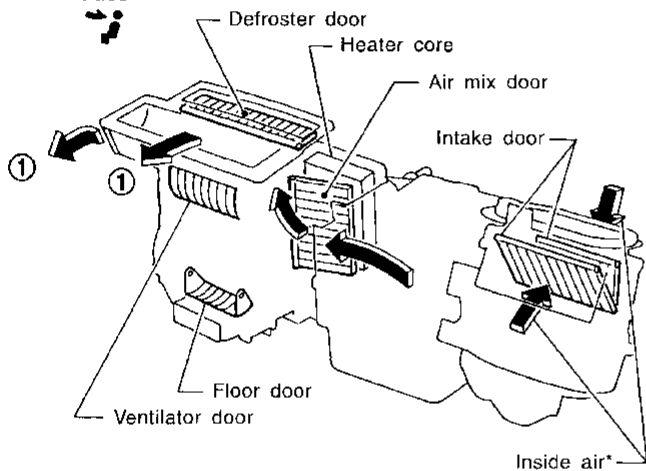

Foot and defroster

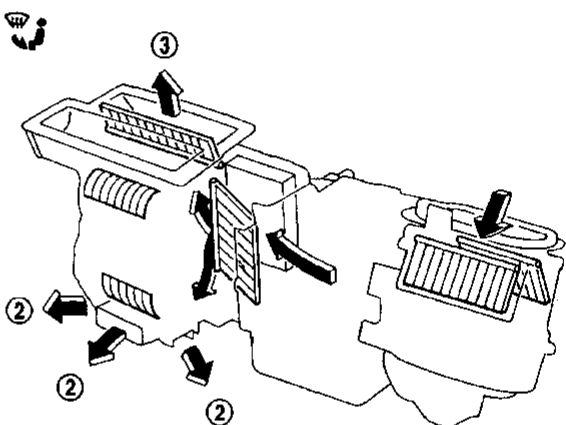

Bi-level

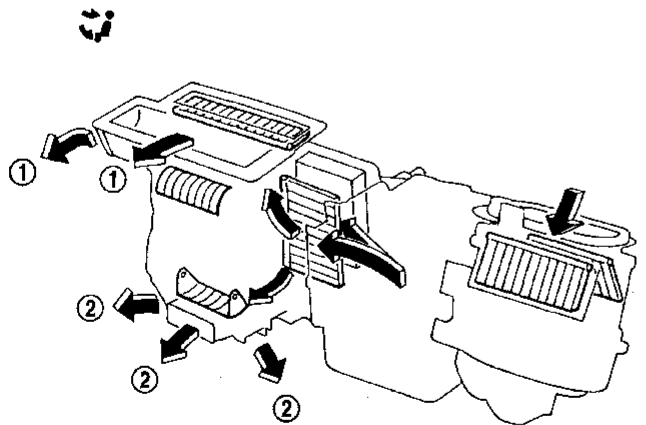

Defroster

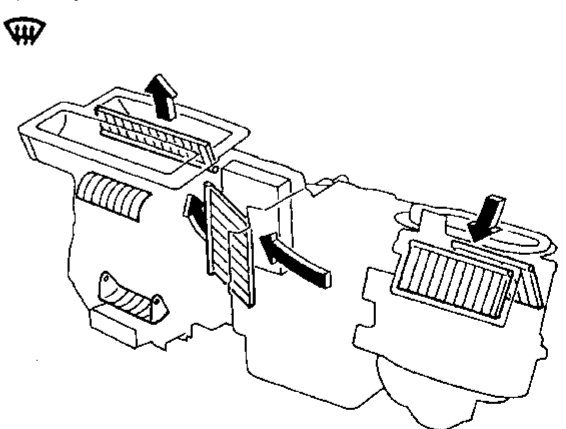

① : To face

② : To foot

③ : To defroster

* : When recirculation switch is ON

For air flow %, refer to "Operational Check", "TROUBLE DIAGNOSES".

GI
MA
EM
LC
EC
FE
CL
MT
AT
FA
RA
BR
ST
RS
BT
HA
EL
IDX

Introduction

AIR CONDITIONER LAN SYSTEM OVERVIEW CONTROL SYSTEM

The LAN system consists of auto amp., air mix door motor and mode door motor. A configuration of these components is shown in the diagram below.

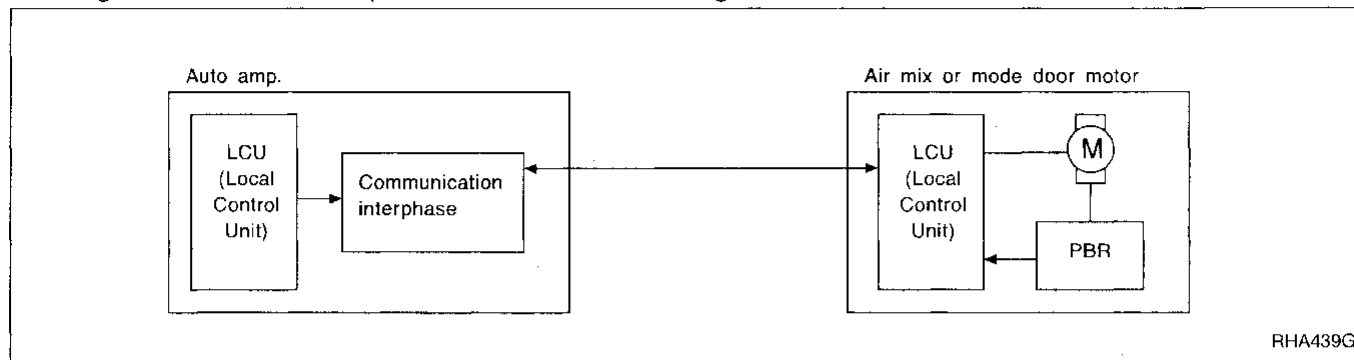

RHA439G

Features

System construction (LAN)

A small network is constructed between the auto amplifier, air mix door motor and mode door motor. The auto amplifier and motors are connected by data transmission lines and motor power supply lines. The LAN network is built through the ground circuits of the two motors.

Addresses, motor opening angle signals, motor stop signals and error checking messages are all transmitted through the data transmission lines connecting the auto amplifier and two motors.

The following functions are contained in LCUs built into the air mix door motor and the mode door motor.

- Address
- Motor opening angle signals
- Data transmission
- Motor stop and drive decision
- Opening angle sensor (PBR function)
- Comparison
- Decision (Auto amplifier indicated value and motor opening angle comparison)

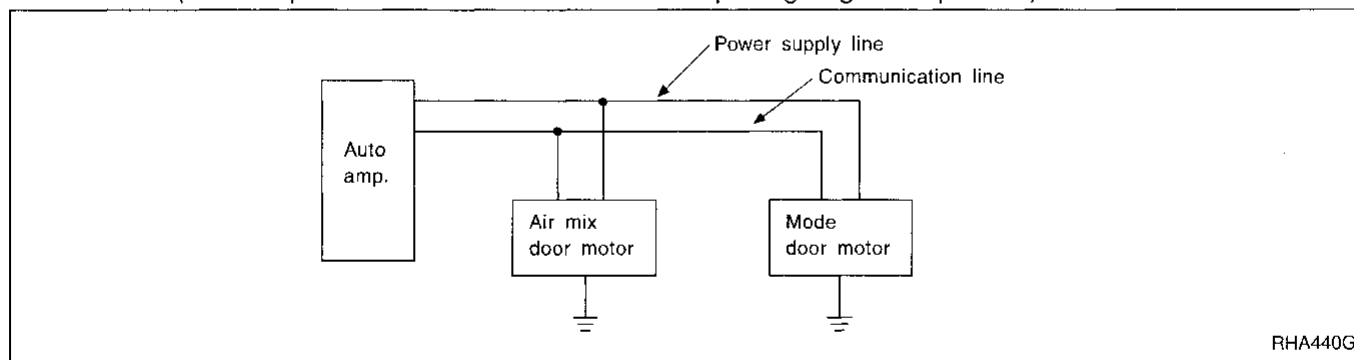

RHA440G

Operation

The auto amplifier receives data from each of the sensors. The amplifier sends air mix door and mode door opening angle data to the air mix door motor LCU and mode door motor LCU.

The air mix door motor and mode door motor read their respective signals according to the address signal. Opening angle indication signals received from the auto amplifier and each of the motor position sensors are compared by the LCUs in each motor with the existing decision and opening angles. Subsequently, HOT/COLD or DEFROST/VENT operation is selected. The new selection data is returned to the auto amplifier.

DESCRIPTION

Features (Cont'd)

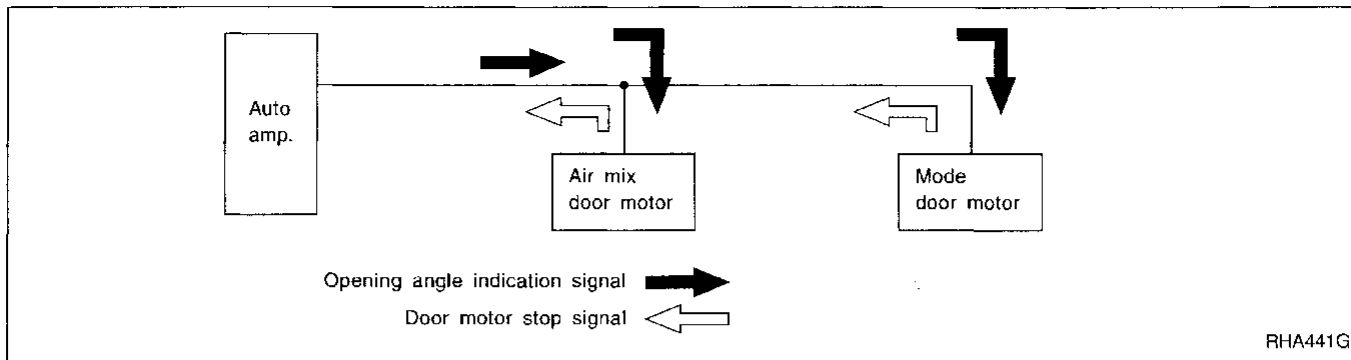

GI
MA
EM

Transmission data and transmission order

Amplifier data is transmitted consecutively to each of the door motors following the form shown in figure below. Start: Initial compulsory signal sent to each of the door motors.

Address: Data sent from the auto amplifier is selected according to data-based decisions made by the air mix door motor and mode door motor.

If the addresses are identical, the opening angle data and error check signals are received by the door motor LCUs. The LCUs then make the appropriate error decision. If the opening angle data is normal, door control begins.

If an error exists, the received data is rejected and corrected data received. Finally, door control is based upon the corrected opening angle data.

Opening angle: Data that shows the indicated door opening angle of each door motor.

Error check: Procedure by which sent and received data is checked for errors. Error data is then compiled. The error check prevents corrupted data from being used by the air mix door motor and mode door motor.

Error data can be related to the following problems.

- Abnormal electrical frequency
- Poor electrical connections
- Signal leakage from transmission lines
- Signal level fluctuation

Stop signal: At the end of each transmission, a stop operation, in-operation, or internal problem message is delivered to the auto amplifier. This completes one data transmission and control cycle.

LC
EC
FE
CL
MT
AT
FA

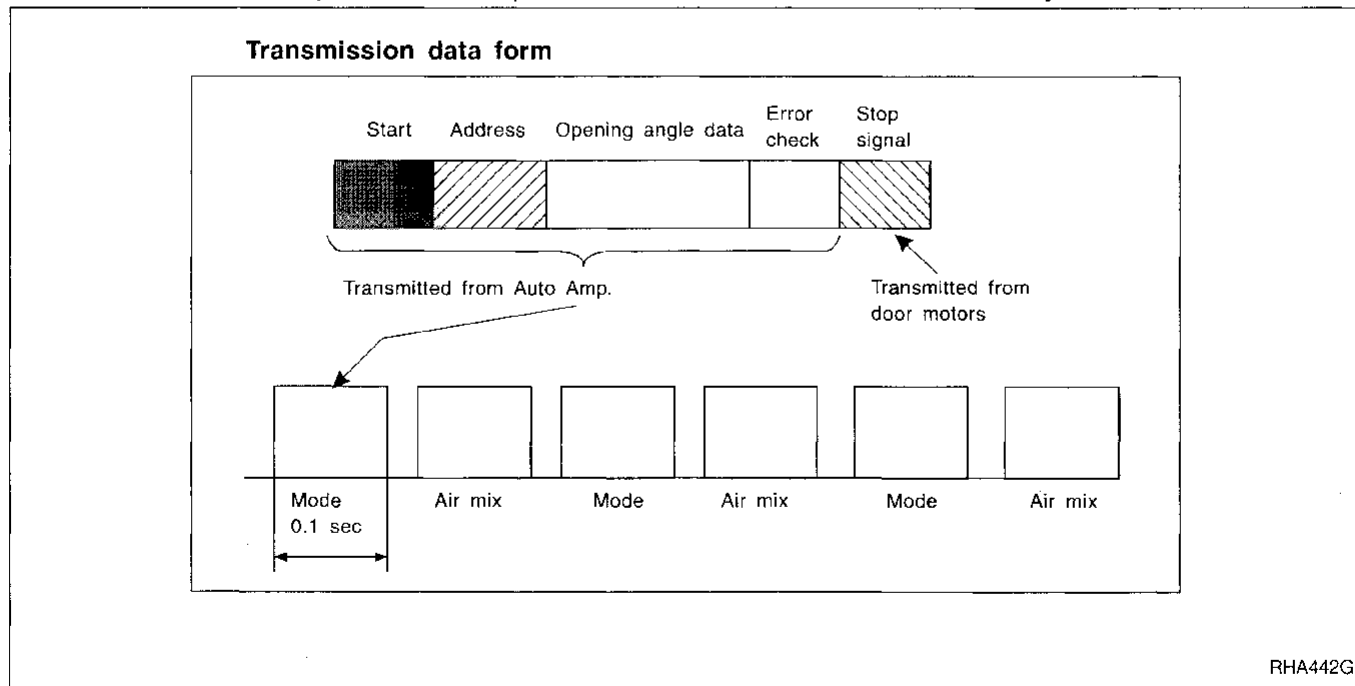

RA
BR
ST
RS
BT
HA
EL
IDX

Air mix door control (Automatic temperature control)

The air mix door is automatically controlled so that in-vehicle temperature is maintained at a predetermined value by: The temperature setting, ambient temperature, in-vehicle temperature and amount of sunload.

DESCRIPTION

Features (Cont'd)

Fan speed control

Blower speed is automatically controlled based on temperature setting, ambient temperature, in-vehicle temperature, intake temperature, amount of sunload and air mix door position.

With FAN switch set to "AUTO", the blower motor starts to gradually increase air flow volume.

When engine coolant temperature is low, the blower motor operation is delayed to prevent cool air from flowing.

Intake door control

The intake doors are automatically controlled by: The temperature setting, ambient temperature, in-vehicle temperature, intake temperature, amount of sunload and ON-OFF operation of the compressor.

Outlet door control

The outlet door is automatically controlled by: The temperature setting, ambient temperature, in-vehicle temperature, intake temperature and amount of sunload.

Magnet clutch control

The ECM (ECCS control module) controls compressor operation using input signals from the throttle position sensor and auto amplifier.

Self-diagnostic system

The self-diagnostic system is built into the auto amplifier (LCU) to quickly locate the cause of problems.

DESCRIPTION

Control Operation

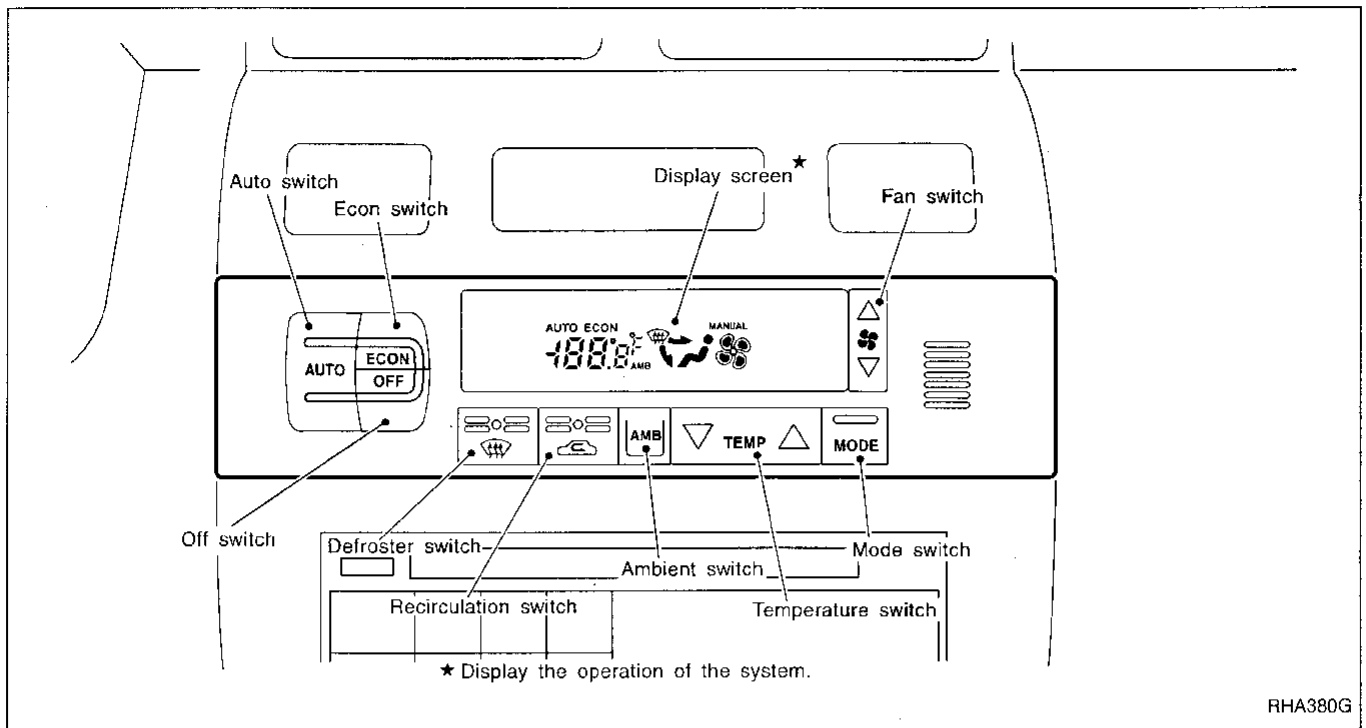

GI
MA
EM
LC
EC
FE
CL
MT
AT
FA
RA
BR
ST
RS
BT
HA
EL
IDX

AUTO SWITCH

The compressor, air intake doors, air mix door, mode doors, and blower speed are automatically controlled so that the in-vehicle temperature will reach, and be maintained at the set temperature selected by the operator. **The air conditioning cooling function operates only when the engine is running.**

ECON SWITCH

Fully automatic control with the compressor off. With the compressor off, the system will not remove heat (cool) or de-humidify. The system will maintain the in-vehicle temperature at the set temperature when the set temperature is above the ambient (outside) temperature.

TEMPERATURE SWITCH (Potentio Temperature Control)





Increases or decreases the set temperature.

OFF SWITCH

The compressor and blower are off, the air intake doors are set to the outside air position. Then, the mode doors are set to the foot (78% foot and 22% defrost) position. In the off position the ATC system uses the vehicle's "flow through" ventilation. It tries to maintain the interior temperature based on the last set temperature of the system.





FAN SWITCH

Manual control of the blower speed. Four speeds are available for manual control (as shown on the display screen):

low  , medium low  , medium high  , high 

MODE SWITCH

Manual control of the air discharge outlets. Four selections are available (as shown on the display screen):

face  , bi-level  , foot  , defrost/foot 

AMBIENT SWITCH

Shows the ambient (outside) air temperature on display screen for 5 seconds.

DESCRIPTION

Control Operation (Cont'd)

RECIRCULATION (REC) SWITCH

ON position: Interior air is recirculated inside the vehicle.

OFF position: Automatic control resumes.

Recirculation is canceled when AUTO, DEF or ECON is selected. Recirculation resumes when another mode is chosen.

DEFROSTER (DEF) SWITCH

Positions the mode doors to the defrost position. Also positions the air intake doors to the outside air position. The compressor operates at ambient temperature approx. 2°C (35°F) or above.

TROUBLE DIAGNOSES

How to Perform Trouble Diagnoses for Quick and Accurate Repair

WORK FLOW

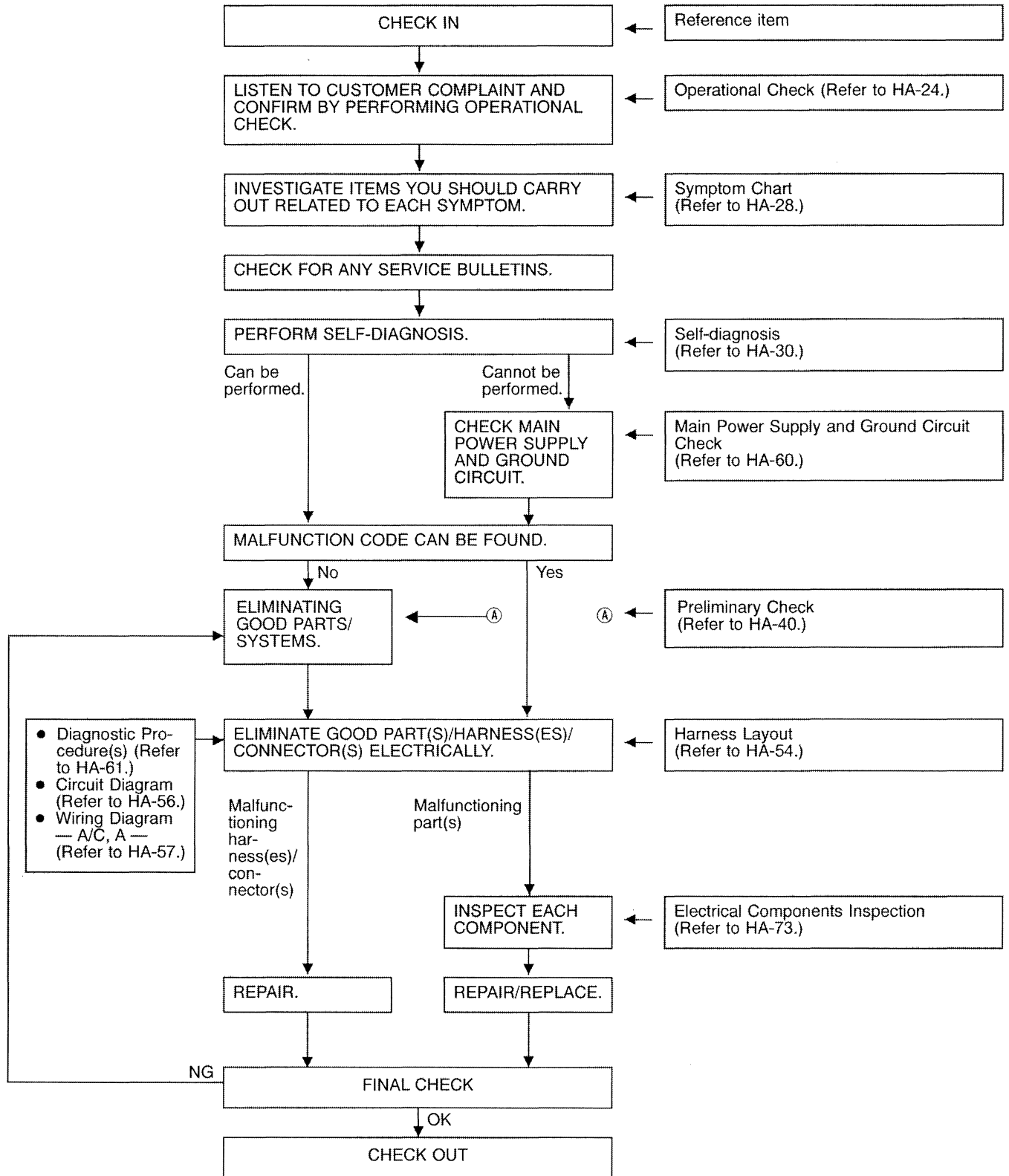

GI
MA
EM
LC
EC
FE
CL
MT
AT
FA
RA
BR
ST
RS
BT
HA
EL
IDX

Operational Check



The purpose of the operational check is to confirm that the system is as it should be. The systems which will be checked are the blower, mode (discharge air), intake air, temperature decrease, temperature increase, A/C switch and the memory function.

CONDITIONS:

- Engine running and at normal operating temperature.

PROCEDURE:

1. Check blower

- 1) Press fan switch (up side) one time.
Blower should operate on low speed.
The fan symbol should have one blade lit .
- 2) Press fan switch (up side) one more time.
- 3) Continue checking blower speed and fan symbol until all speeds are checked.
- 4) Leave blower on MAX speed .

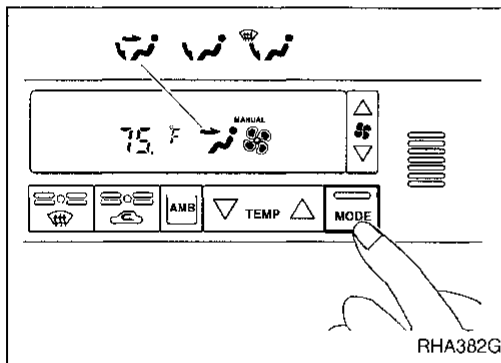
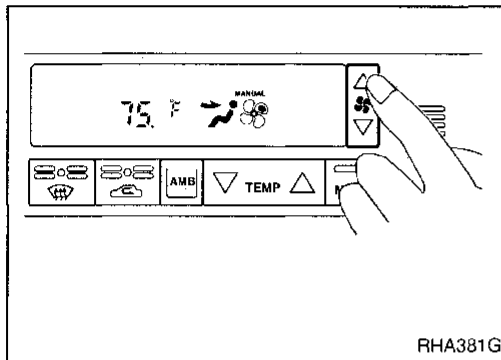

2. Check discharge air

- 1) Press mode switch four times and DEF button.





- 2) Confirm that discharge air comes out according to the air distribution table at left.

Refer to "Discharge Air Flow", "DESCRIPTION" (HA-17).

NOTE:

Confirm that the compressor clutch is engaged (visual inspection) and intake door position is at FRESH when the DEF button is pressed.

Intake door position is checked in the next step.

Discharge air flow			
Switch mode/ indicator	Air outlet/distribution		
	Face	Foot	Defroster
	100%	—	—
	60%	40%	—
	—	78%	22%
	—	60%	40%
	—	—	100%

RHA429E

TROUBLE DIAGNOSES

Operational Check (Cont'd)

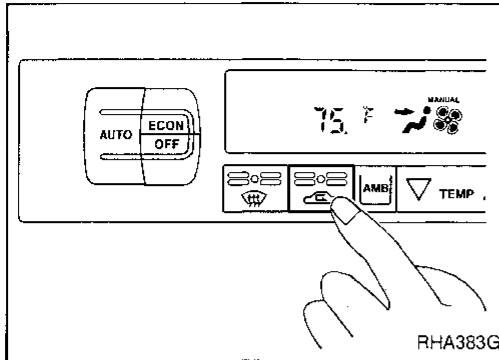

3. Check recirculation

- 1) Press REC  switch.
Recirculation indicator should illuminate.
- 2) Listen for intake door position change (you should hear blower sound change slightly).

GI

MA

EM

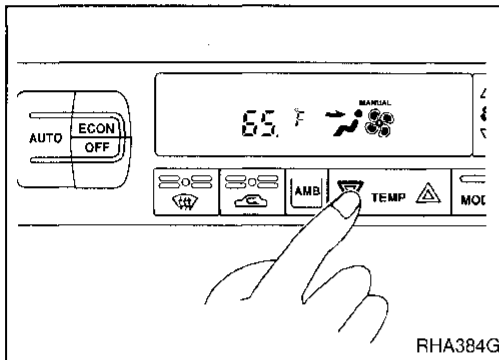

4. Check temperature decrease

- 1) Press the temperature decrease button until 18°C (65°F) is displayed.
- 2) Check for cold air at discharge air outlets.

LC

EC

FE

CL

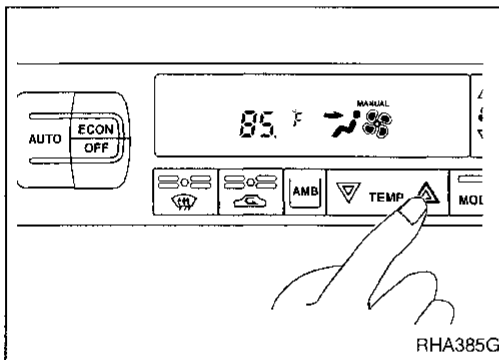

5. Check temperature increase

- 1) Press the temperature increase button until 32°C (85°F) is displayed.
- 2) Check for hot air at discharge air outlets.

MT

AT

FA

RA

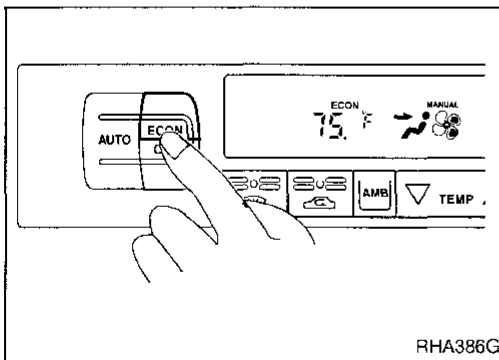

6. Check ECON mode

- 1) Press ECON switch.
- 2) Display should indicate ECON (no AUTO, no MANUAL).
Confirm that the compressor clutch is not engaged (visual inspection).
(Discharge air will depend on ambient, in-vehicle, and set temperatures.)
- 3) Check for intake air at Fresh position.

BR

ST

RS

BT

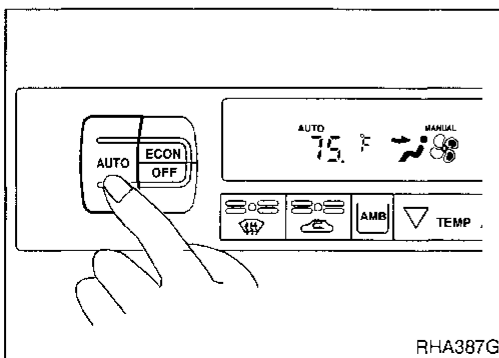

7. Check AUTO mode

- 1) Press AUTO switch.
- 2) Display should indicate AUTO (no ECON, no MANUAL).
Confirm that the compressor clutch engages (audio or visual inspection).
(Discharge air and suction air will depend on ambient, in-vehicle, and set temperatures.)

HA

EL

IDX

TROUBLE DIAGNOSES

Operational Check (Cont'd)

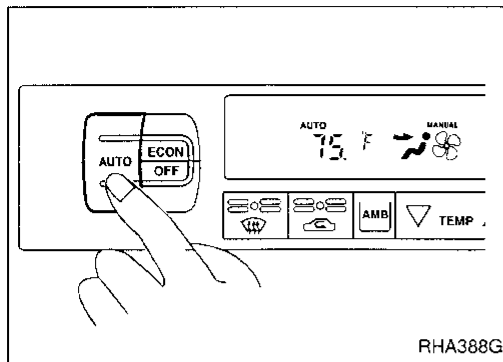

8. Check memory function

- 1) Press OFF switch.
- 2) Turn the ignition off.
- 3) Turn the ignition on.
- 4) Press the AUTO switch.
- 5) Confirm that the set temperature remains at previous temperature.

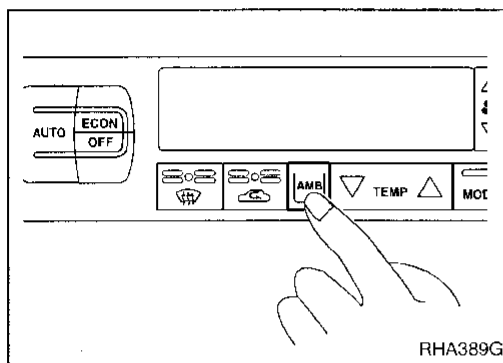

9. Check ambient display

- 1) Press AMB switch.
- 2) Display should show the outside (ambient) temperature for approximately 5 seconds.

TROUBLE DIAGNOSES

NOTE

GI

MA

EM

LC

EC

FE

CL

MT

AT

FA

RA

BR

ST

RS

BT

HA

EL

IDX

TROUBLE DIAGNOSES



Symptom Chart

DIAGNOSTIC TABLE

PROCEDURE	DIAGNOSTIC ITEM AND REFERENCE PAGE	Self-diagnosis					Preliminary Check								Diagnostic Procedure						
		STEP 1 (HA-31, 34)	STEP 2 (HA-31, 34)	STEP 3 (HA-32, 35)	STEP 4 (HA-32, 36)	STEP 5 (HA-33, 37)	AUXILIARY MECHANISM (HA-39)	Preliminary Check 1 (HA-40)	Preliminary Check 2 (HA-41)	Preliminary Check 3 (HA-42)	Preliminary Check 4 (HA-43)	Preliminary Check 5 (HA-44)	Preliminary Check 6 (HA-45)	Preliminary Check 7 (HA-46)	Preliminary Check 8 (HA-47)	Diagnostic Procedure 1 (HA-61)	Diagnostic Procedure 2 (HA-62)	Diagnostic Procedure 3 (HA-63)	Diagnostic Procedure 4 (HA-64)	Diagnostic Procedure 5 (HA-65)	
Air outlet does not change.		①	②	○	○	○		③								○	○		○	○	
Intake door does not change.		①	②	○	○	○			③							○	○		○	○	
Insufficient cooling		○	○	○	○	○	○	○	○	①		○	○			○	○		○	○	
Insufficient heating		○	○	○	○	○	○	○	○		①	○	○			○	○		○	○	
Blower motor operation is malfunctioning.		①	②		○	○						③				○	○	○	○	○	
Magnet clutch does not engage.		①	②		○	○							③			○	○		○	○	
Discharged air temperature does not change.		①	②		○	○								③		○	○		○	○	
Noise															①						
Result of self-diagnosis STEP 2	21 Ambient sensor circuit is open.	①	②			③										④					
	22 In-vehicle sensor circuit is open.	①	②			③											④				
	24 Intake sensor circuit is open.	①	②															③			
	25 Sunload sensor circuit is open.	①	②																	③	
	26 PBR signal is open.	①	②																		③
	21 Ambient sensor circuit is shorted.	①	②			③											④				
	22 In-vehicle sensor circuit is shorted.	①	②			③												④			
	24 Intake sensor circuit is shorted.	①	②																③		
	25 Sunload sensor circuit is shorted.	①	②																		③
	26 PBR signal is shorted.	①	②																		③
Either mode door motor or air mix door motor does not operate normally.		①	②	③	④	○										○	○		○	⑤	
Mode door motor and air mix door motor do not operate normally.		①	②		③	○										○	○		○		
Intake door motor does not operate normally.		①	②		③	○										○	○		○	○	
Blower motor operation is malfunctioning under out of Starting Fan Speed Control.		①	②		○	○						③				○	○	○	○	○	
Magnet clutch does not operate after performing Preliminary Check 6.		①	②		○	○							③			○					
Self-diagnosis cannot be performed.																					

① - ⑤ : The numbers refer to the probability of the cause, ① being the most likely.
 ○ : As for checking order, refer to each flow chart. (It depends on malfunctioning portion.)

Self-diagnosis

The self-diagnostic system diagnoses sensors, door motors, blower motor, etc. by system line. Refer to applicable sections (items) for details. Shifting from normal control to the self-diagnostic system is done as follows. Start the engine (turn the ignition switch from "OFF" to "ON"). And press "OFF" switch for at least 5 seconds. The "OFF" switch must be pressed within 5 seconds after starting the engine (ignition switch is turned "ON"). This system will be canceled by either pressing  switch or turning the ignition switch "OFF". Shifting from one step to another is accomplished by means of pushing  (HOT) or  (COLD) switch, as required.

Additionally shifting from STEP 5 to AUXILIARY MECHANISM is accomplished by means of pushing  (fan up) switch.

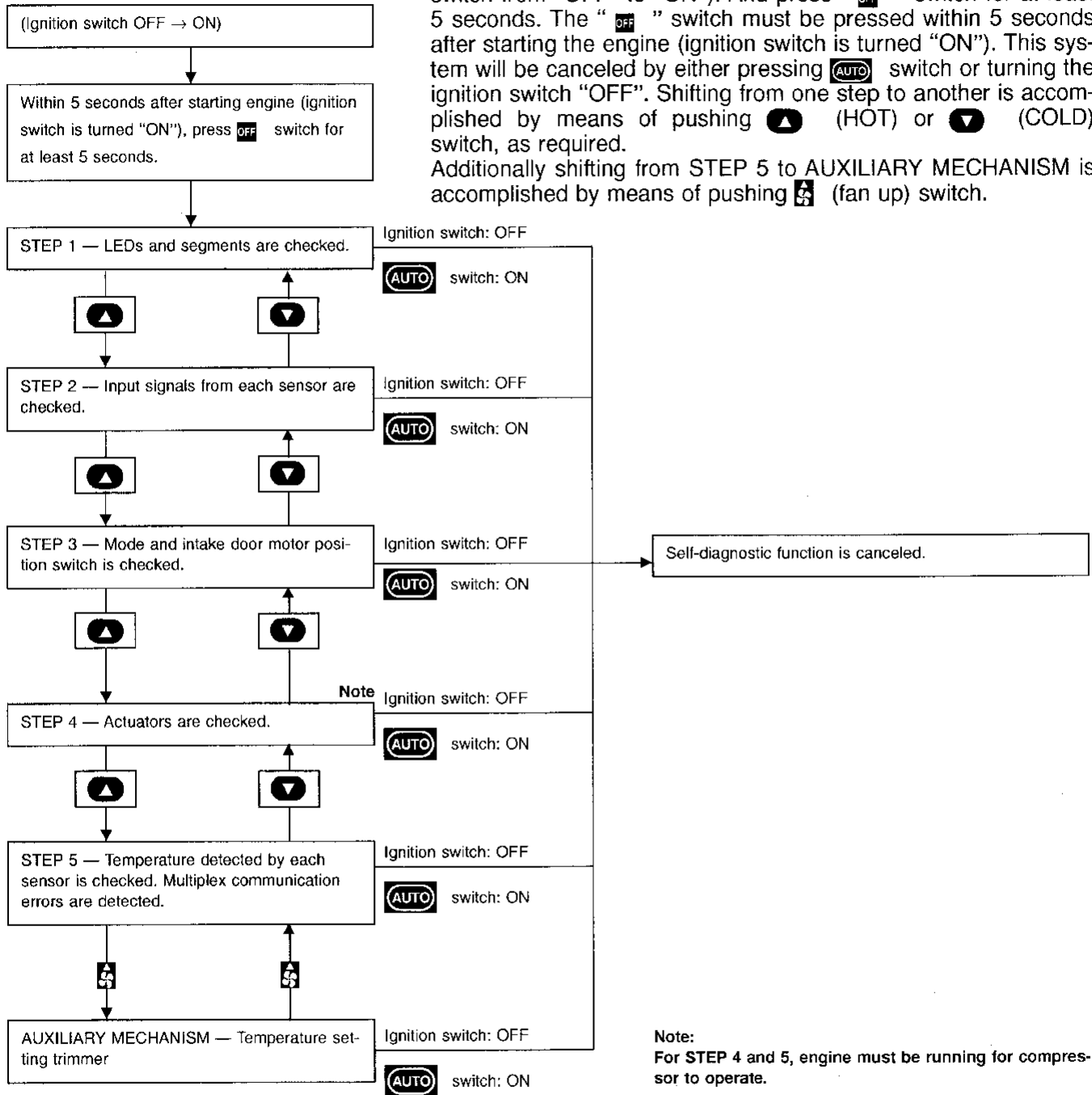

TROUBLE DIAGNOSES

Self-diagnosis (Cont'd)

CHECKING PROCEDURE

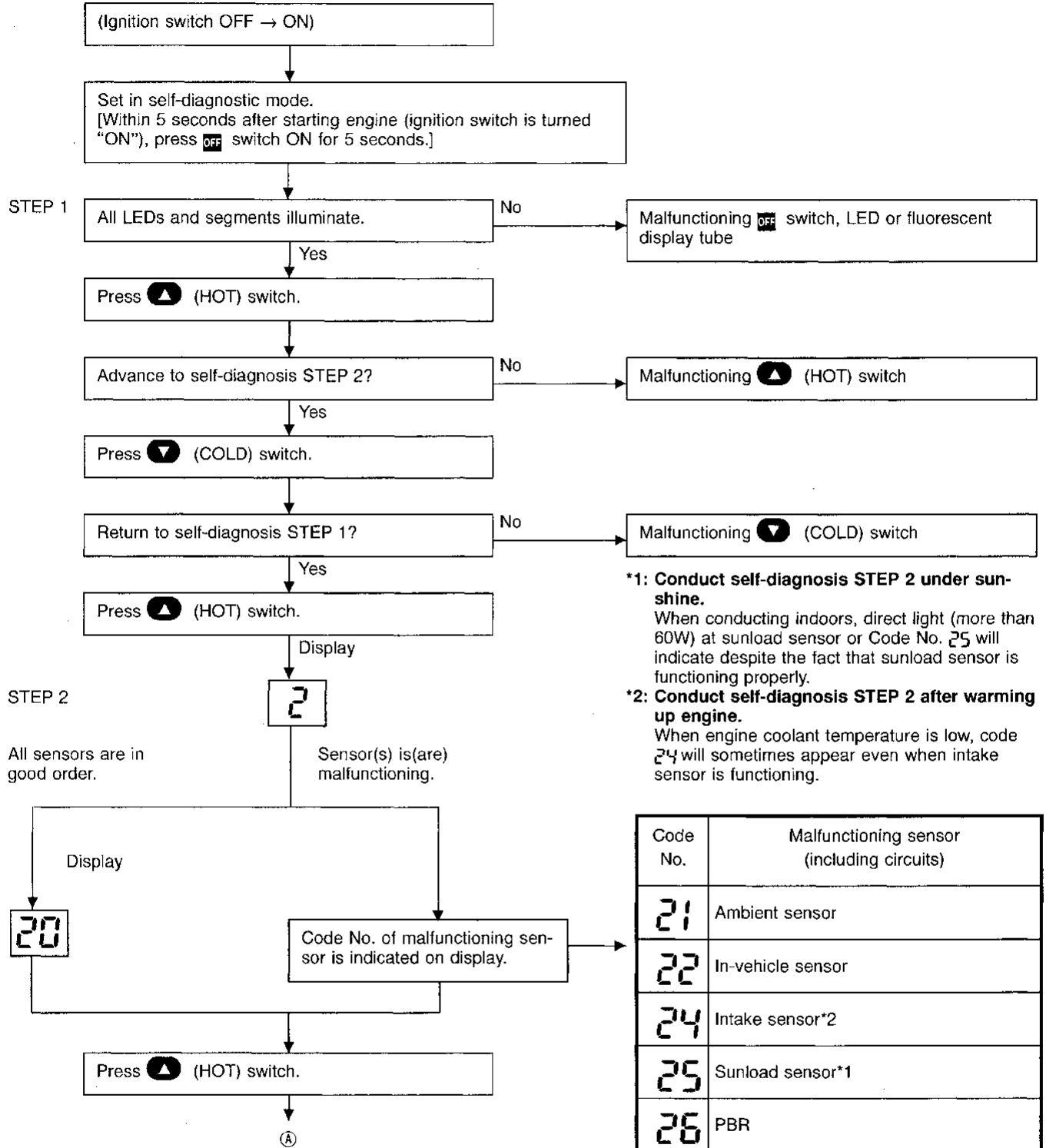

Note:
At any time, you can return to a previous step in the self-diagnosis by pressing the ▼ (COLD) switch.

TROUBLE DIAGNOSES

Self-diagnosis (Cont'd)

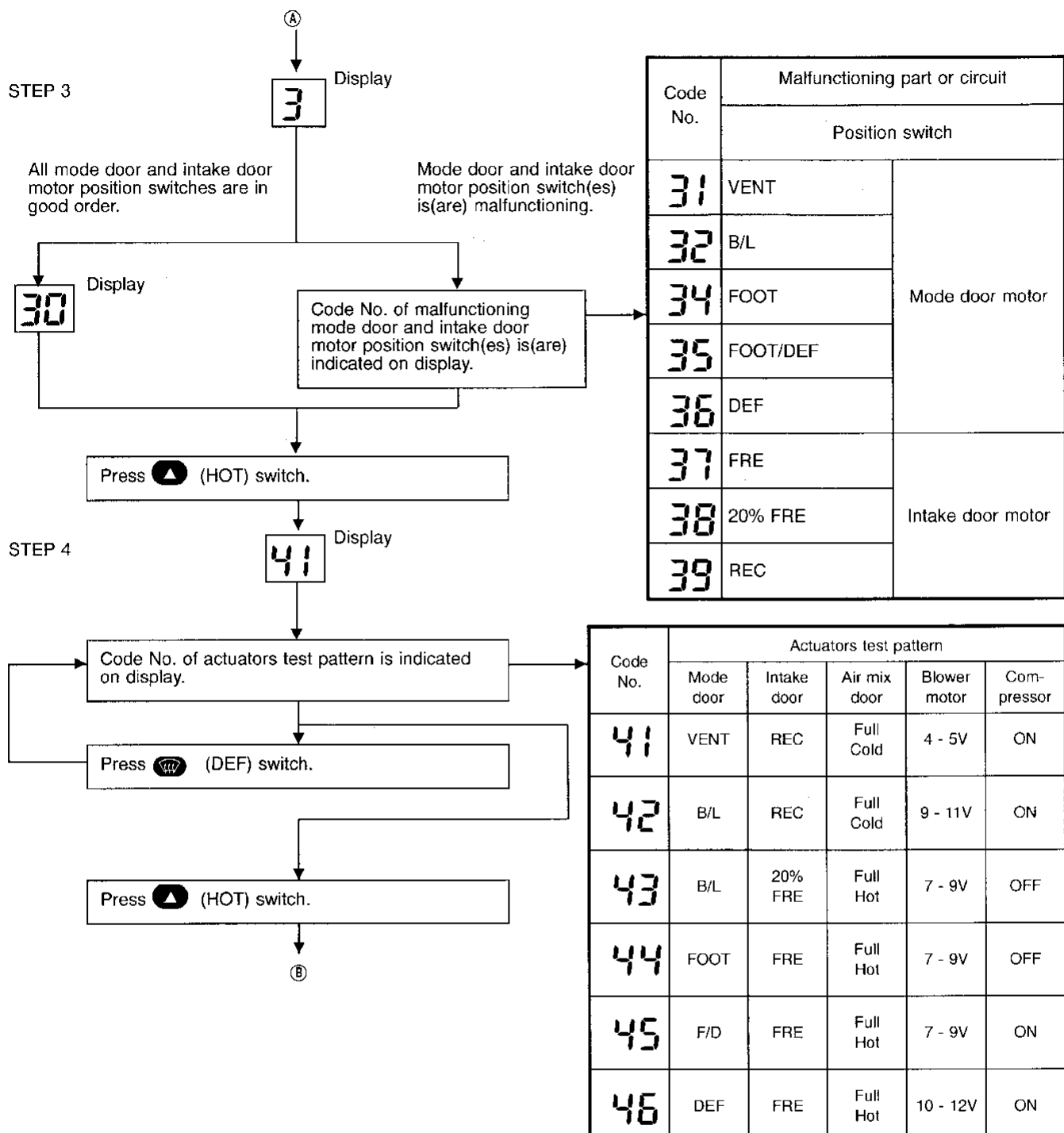

Note:
For STEP 4, engine must be running for compressor to operate.

TROUBLE DIAGNOSES

Self-diagnosis (Cont'd)

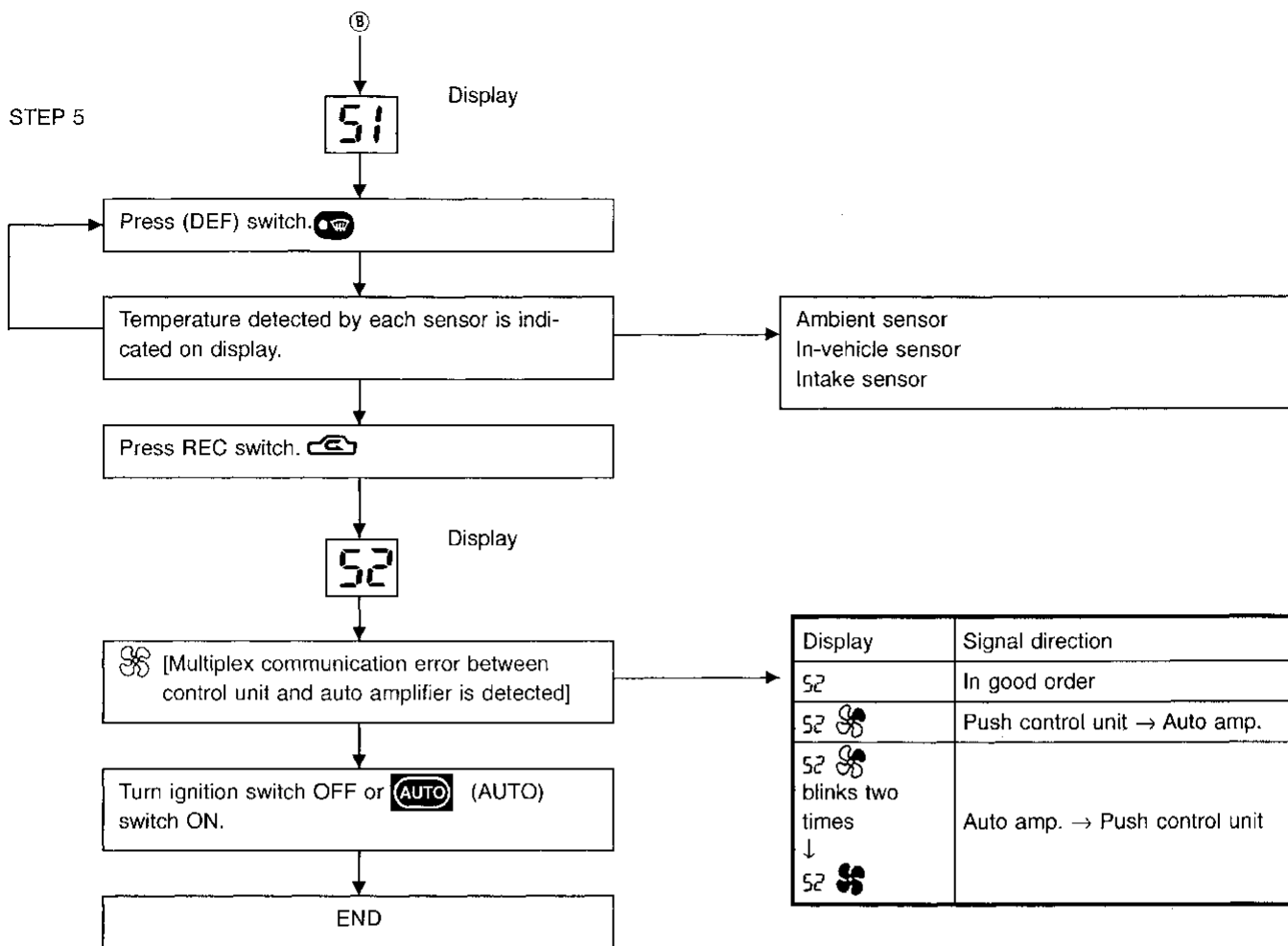

GI
MA
EM
LC
EC
FE
CL
MT
AT
FA
RA
BR
ST
RS
BT
HA
EL
IDX

TROUBLE DIAGNOSES

Self-diagnosis (Cont'd)

HOW TO INTERPRET THE RESULTS

STEP 1: Checks LEDs and segments

When switch's LED and segments are in functioning properly in STEP 1, LED and display will come on.

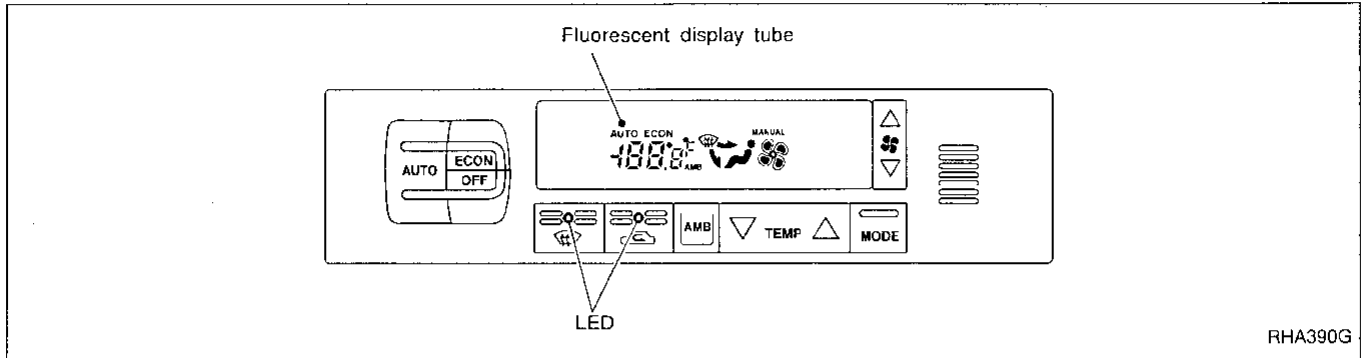

Display malfunction

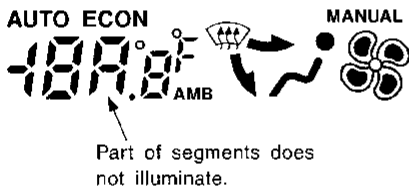

If LEDs or segments malfunction, LED will not come on or display will show incomplete segment.

Display (when all sensors are in good order)

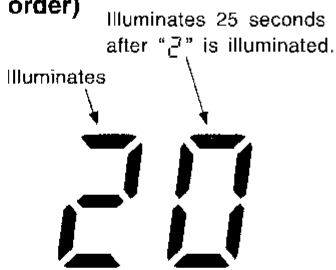

STEP 2: Checks each sensor circuit for open or short circuit

Display shows "2" in STEP 2 mode.

When all sensors are in good order, display shows "20".

It takes approximately 25 seconds to check all sensors.

Display (when sensor malfunctions)

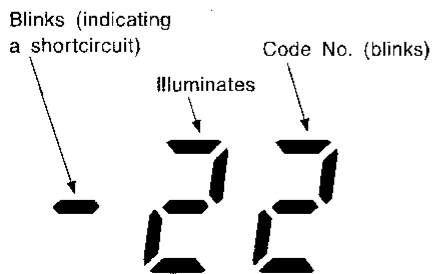

If a sensor is malfunctioning, the corresponding code No. blinks on display. A short circuit is identified by a blinking "-" mark preceding mode number.

TROUBLE DIAGNOSES

Self-diagnosis (Cont'd)

If two or more sensors malfunction, corresponding code Nos. respectively blink two times.

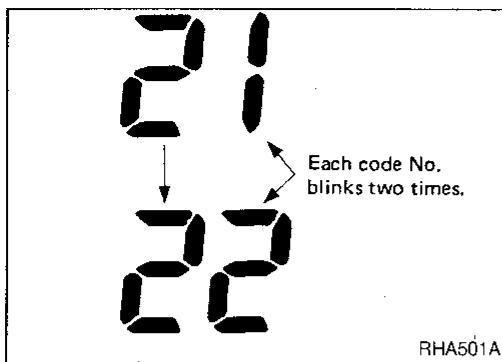

Sensors and abnormalities

If a circuit is opened or shorted, display shows its code No. when input corresponds with any of following conditions.

Code No.	Sensor	Open circuit	Short circuit
21 -21	Ambient sensor	Less than -41.9°C (-43°F)	Greater than 100°C (212°F)
22 -22	In-vehicle sensor	Less than -41.9°C (-43°F)	Greater than 100°C (212°F)
24 -24	Intake sensor	Less than -43.8°C (-47°F)	Greater than 100°C (212°F)
25 -25	Sunload sensor*2	Less than 0.01515 mA	Greater than 0.545 mA
26 -26	PBR*1	Greater than 0.05%	Less than 0.95%

*1: "0.05%" and "0.95%" refer to percentage with respect to full stroke of air mix door. (Full cold: 0%, Full hot: 100%)

*2: **Conduct self-diagnosis STEP 2 under sunshine.**

When conducting indoors, direct light (more than 60W) at sunload sensor.

*3: **Conduct self-diagnosis STEP 2 after warming up engine.**

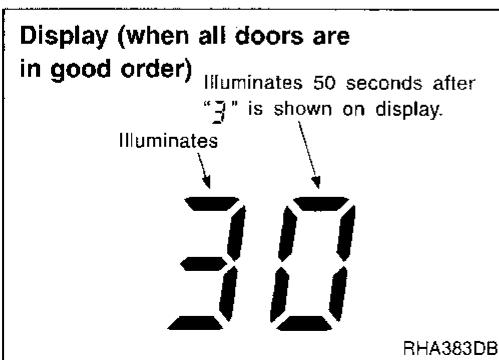

STEP 3: Checks mode and intake door positions

Display shows "3" in STEP 3 mode.

When all doors are in good order, display will then show "30".

It takes approximately 50 seconds to check all mode and intake doors.

TROUBLE DIAGNOSES

Self-diagnosis (Cont'd)

When abnormalities are detected, display shows a code No. corresponding with malfunctioning part.

Code No.	31	32	34	35	36	37	38	39
Malfunctioning part	VENT	B/L	FOOT	FOOT/DEF	DEF	FRE	20% FRE	REC

Display (when a door is out of order)

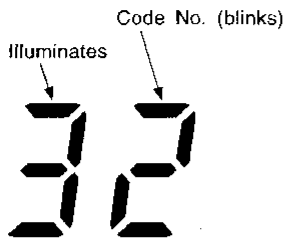

RHA394G

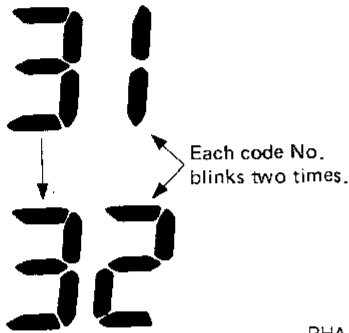

RHA498A

If two or more mode or intake doors are out of order, corresponding code numbers respectively blink two times.

If mode door motor harness connector is disconnected, the following display pattern will appear.

31 → 32 → 34 → 35 → 36

If intake mode door harness connector is disconnected, the following display pattern will appear.

37 → 38 → 39

If any mode door motor position switch is malfunctioning, mode door motor will also malfunction.

STEP 4: Checks operation of each actuator

Display shows "41" in STEP 4 mode.

When  DEF switch is pressed one time, display shows "42". Thereafter, each time the switch is pressed, display advances one number at a time, up to "46", then returns to "41".

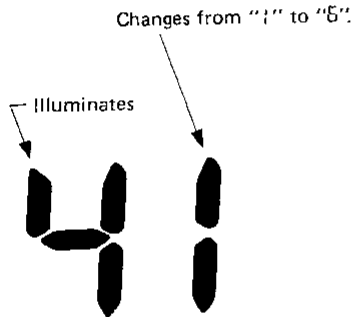

RHA495A

During inspection in STEP 4, the auto amp. will forcefully transmit an output to the affected actuators. The corresponding code Nos. are shown on display as indicated in the table below.

Checks must be made visually, by listening to any noise, or by touching air outlets with your hand, etc. for improper operation.

Code No.	41	42	43	44	45	46
Actuator	VENT	B/L	B/L	FOOT	F/D	DEF
Mode door	VENT	B/L	B/L	FOOT	F/D	DEF
Intake door	REC	REC	20% FRE	FRE	FRE	FRE
Air mix door	Full Cold	Full Cold	Full Hot	Full Hot	Full Hot	Full Hot
Blower motor	4 - 5 V	9 - 11 V	7 - 9 V	7 - 9 V	7 - 9 V	10 - 12 V
Compressor	ON	ON	OFF	OFF	ON	ON

Operating condition of each actuator cannot be checked by indicators.

Discharge air flow

Switch mode/ indicator	Air outlet/distribution		
	Face	Foot	Defroster
	100%	—	—
	60%	40%	—
	—	78%	22%
	—	60%	40%
	—	—	100%

RHA429E



TROUBLE DIAGNOSES

Self-diagnosis (Cont'd)

STEP 5: Checks temperature detected by sensors, and detects multiplex communication error

Checks temperature detected by sensors

Display shows "51" in STEP 5 mode.

- When  FRONT DEF switch is pressed one time, display shows temperature detected by ambient sensor.
- When  FRONT DEF switch is pressed second time, display shows temperature detected by in-vehicle sensor.
- When  FRONT DEF switch is pressed third time, display returns to original presentation "51".

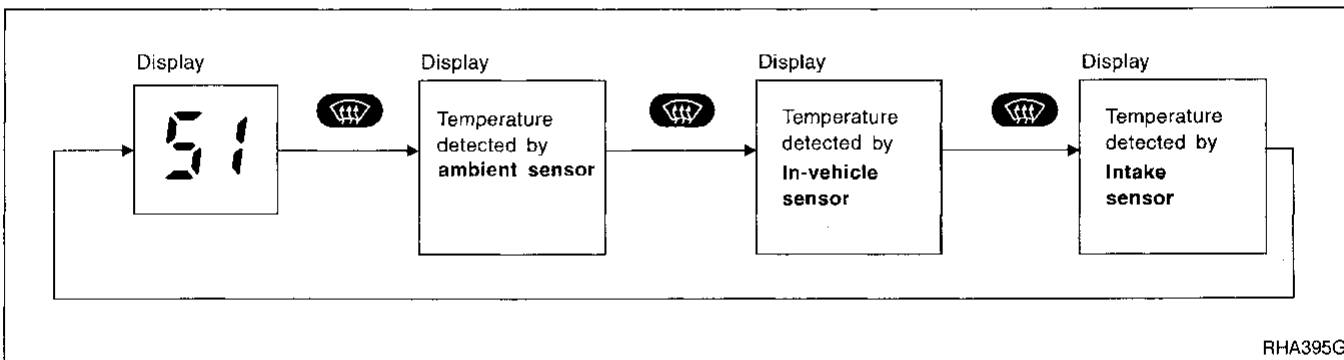
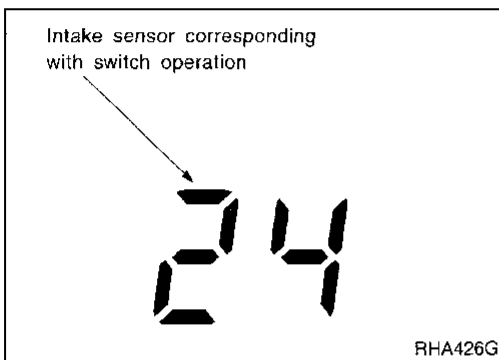
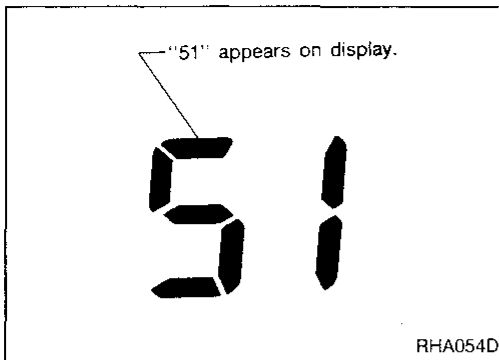

If temperature shown on display greatly differs from actual temperature, check sensor circuit at first. Then inspect sensor itself according to the procedures described in **Control System Input Component**. Refer to HA-77.

GI
MA
EM
LC
EC
FE
CL
MT
AT
FA
RA
BR
ST
RS
BT
HA
EL
IDX

TROUBLE DIAGNOSES

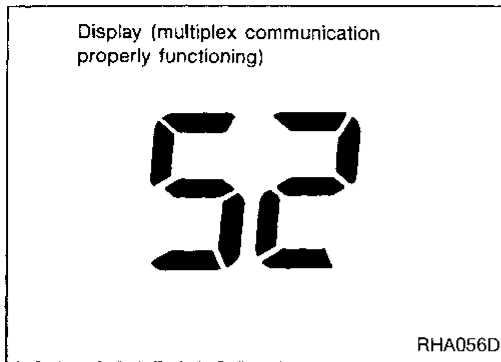



Self-diagnosis (Cont'd)

Detects multiplex communication error

Display shows "52" in STEP 5 mode.

[Multiplex communication error between push control unit and auto amplifier is detected]

Display	Signal direction
52	In good order
52 	Push control unit → auto amp.
52  blinks two times. ↓	Auto amp. → Push control unit
52 	

CAUTION:

The auto amp. memorizes any communication error in the system in a normal control with battery connected. When there is an error, display will be as shown above. When plural errors occur, the display of each error will blink two times for 0.5 second intervals.

If a communication error is displayed, follow the flow chart below. Determine if the error occurred in the past or is currently happening.



TROUBLE DIAGNOSES

Self-diagnosis (Cont'd)

AUXILIARY MECHANISM: Temperature setting trimmer

This trimmer compensates for differences between temperature setting (displayed digitally) and temperature felt by driver in a range of $\pm 3^{\circ}\text{C}$ ($\pm 6^{\circ}\text{F}$).

Operating procedures for this trimmer are as follows:

Starting with STEP 5 under "Self-diagnostic mode", press  (fan up) switch to set air conditioning system in auxiliary mode. Display shows "5:" in auxiliary mechanism. It takes approximately 3 seconds. Then, press either  (HOT) or  (COLD) switch as desired. Temperature will change at a rate of 0.5°C (1°F) each time a switch is pressed.

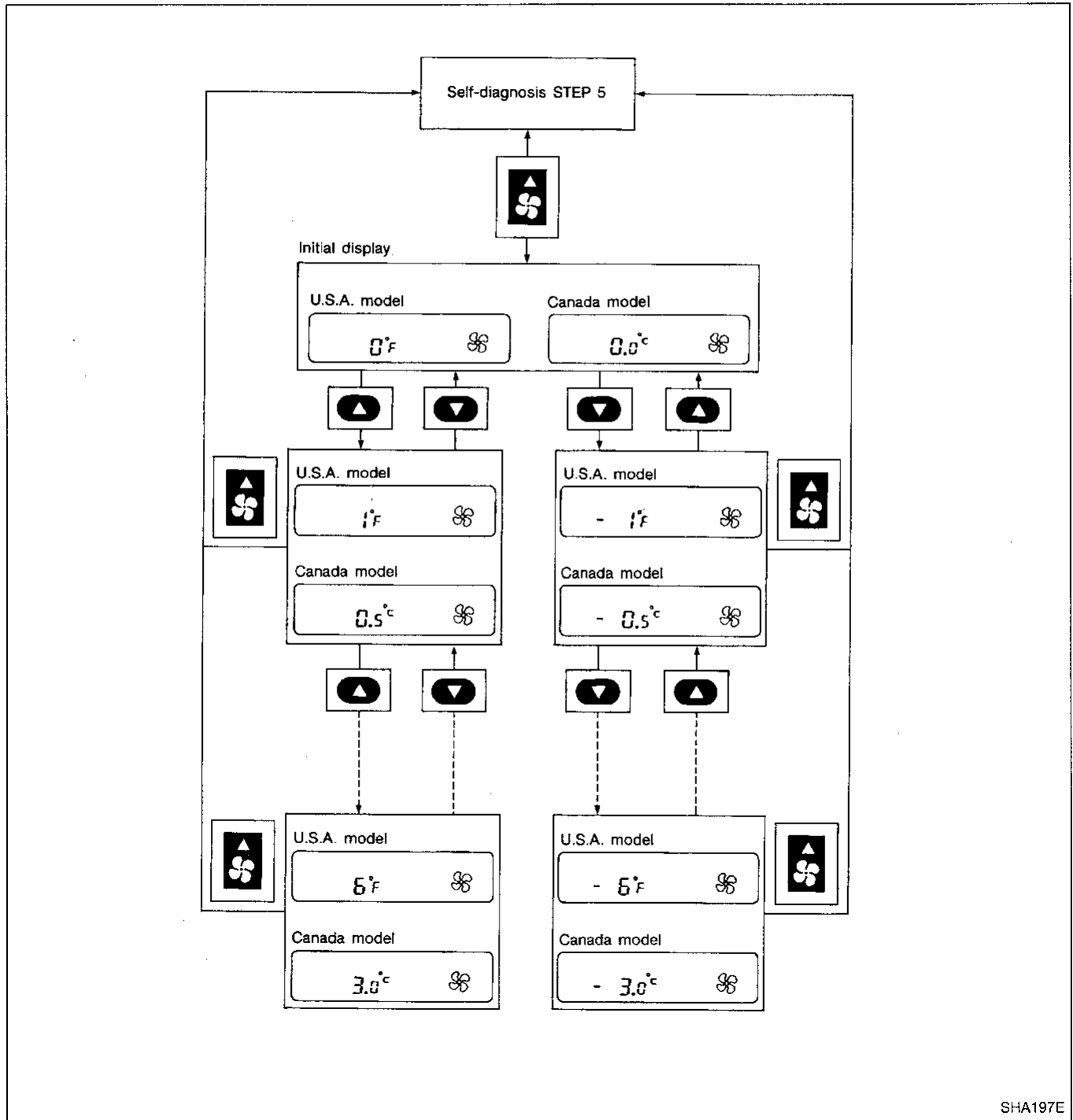

SHA197E

When battery cable is disconnected, trimmer operation is canceled and temperature set becomes that of initial condition, i.e. 0°C (0°F).

TROUBLE DIAGNOSES

Preliminary Check

PRELIMINARY CHECK 1

Air outlet does not change.

- Perform Self-diagnosis STEP 1 before referring to the flow chart.

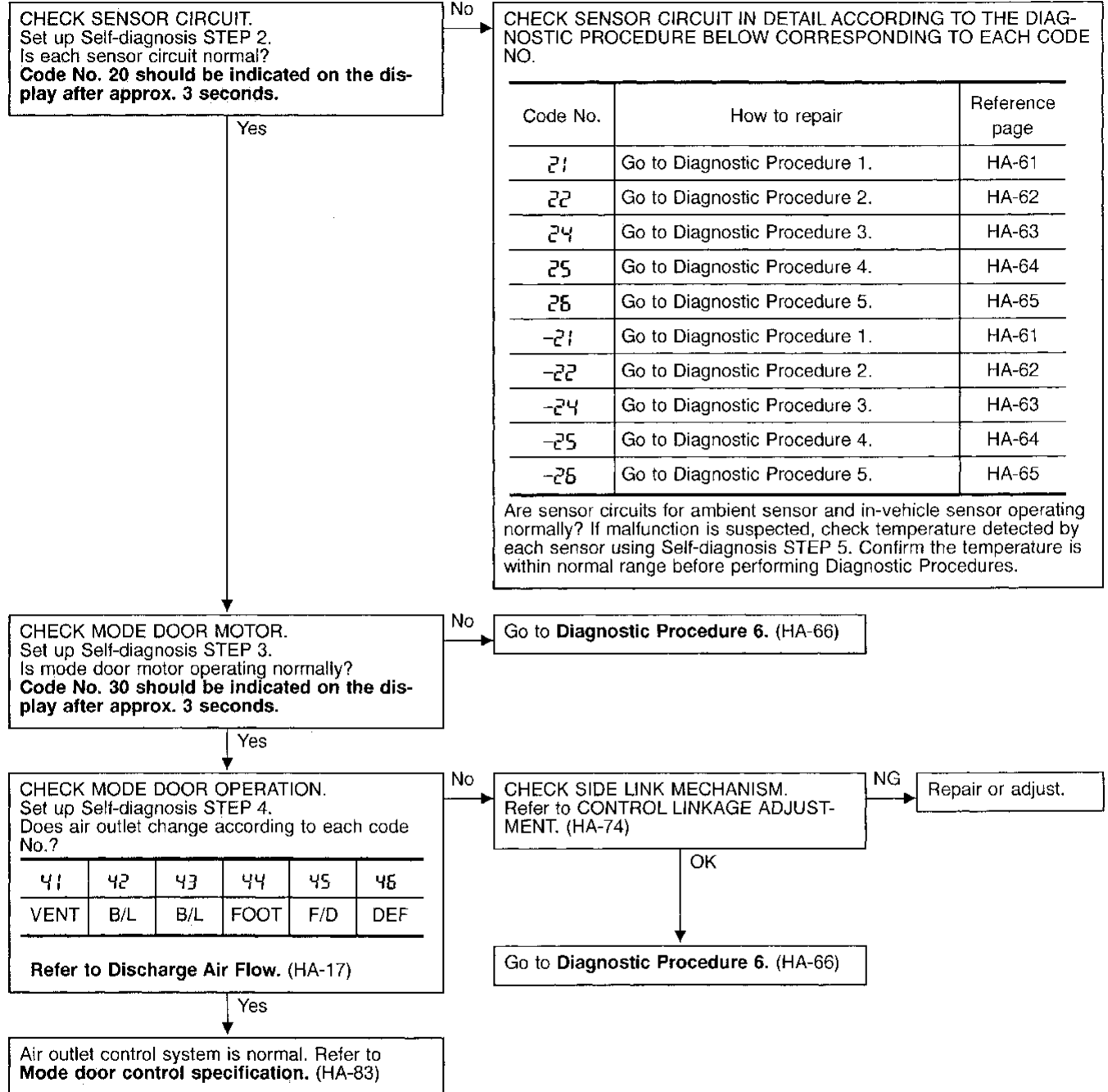

TROUBLE DIAGNOSES

Preliminary Check (Cont'd)

PRELIMINARY CHECK 2

Intake door does not change.

- Perform Self-diagnosis STEP 1 before referring to the following flow chart.

CHECK SENSOR CIRCUIT.
Set up Self-diagnosis STEP 2.
Is each sensor circuit normal?
Code No. 20 should be indicated on the display after approx. 3 seconds later.

No

CHECK SENSOR CIRCUIT IN DETAIL ACCORDING TO THE DIAGNOSTIC PROCEDURE BELOW CORRESPONDED TO EACH CODE NO.

Code No.	How to repair	Reference page
21	Go to Diagnostic Procedure 1.	HA-61
22	Go to Diagnostic Procedure 2.	HA-62
24	Go to Diagnostic Procedure 3.	HA-63
25	Go to Diagnostic Procedure 4.	HA-64
26	Go to Diagnostic Procedure 5.	HA-65
-21	Go to Diagnostic Procedure 1.	HA-61
-22	Go to Diagnostic Procedure 2.	HA-62
-24	Go to Diagnostic Procedure 3.	HA-63
-25	Go to Diagnostic Procedure 4.	HA-64
-26	Go to Diagnostic Procedure 5.	HA-65

Are sensor circuits for ambient sensor and in-vehicle sensor operating normally? If malfunction is suspected, check temperature detected by each sensor using Self-diagnosis STEP 5. Confirm the temperature is within normal range before performing Diagnostic Procedures.

Yes

CHECK INTAKE DOOR MOTOR OPERATION.
Set up Self-diagnosis STEP 4.
Does intake air change according to each code No.?

No

CHECK INTAKE DOOR ROD or LEVER MECHANISM.
Refer to CONTROL LINKAGE ADJUSTMENT. (HA-74)

NG

Repair or adjust.

41	42	43	44	45	46
REC	REC	20% FRE	FRE	FRE	FRE

Yes

Intake door control system is normal.
Refer to **Intake door control specification.** (HA-84)

OK

Go to **Diagnostic Procedure 7.** (HA-67)

GI

MA

EM

LC

EC

FE

CL

MT

AT

FA

RA

BR

ST

RS

BT

HA

EL

IDX

TROUBLE DIAGNOSES

PRELIMINARY CHECK 3 Insufficient cooling

Preliminary Check (Cont'd)

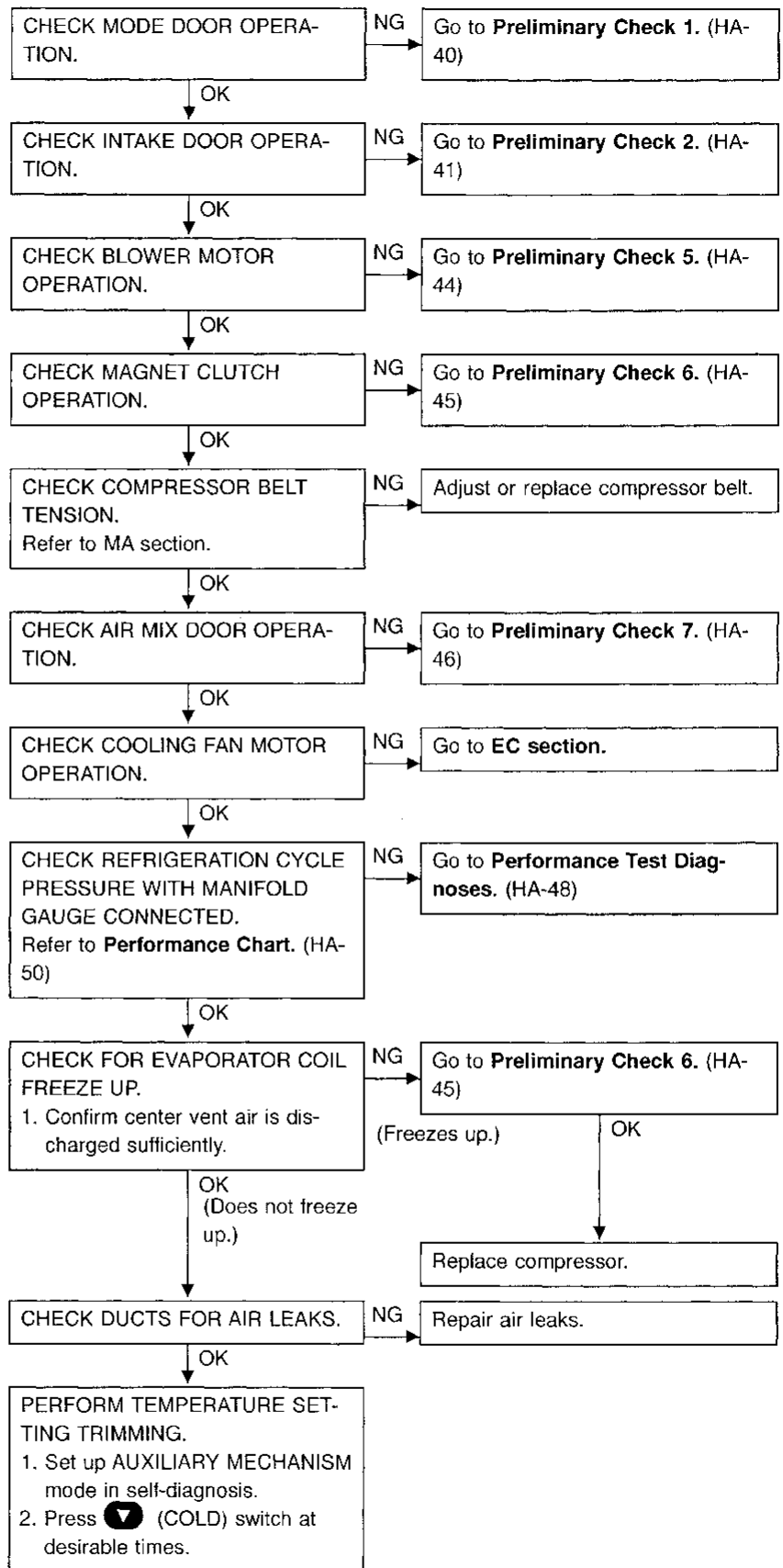

TROUBLE DIAGNOSES

Preliminary Check (Cont'd)

PRELIMINARY CHECK 4

Insufficient heating

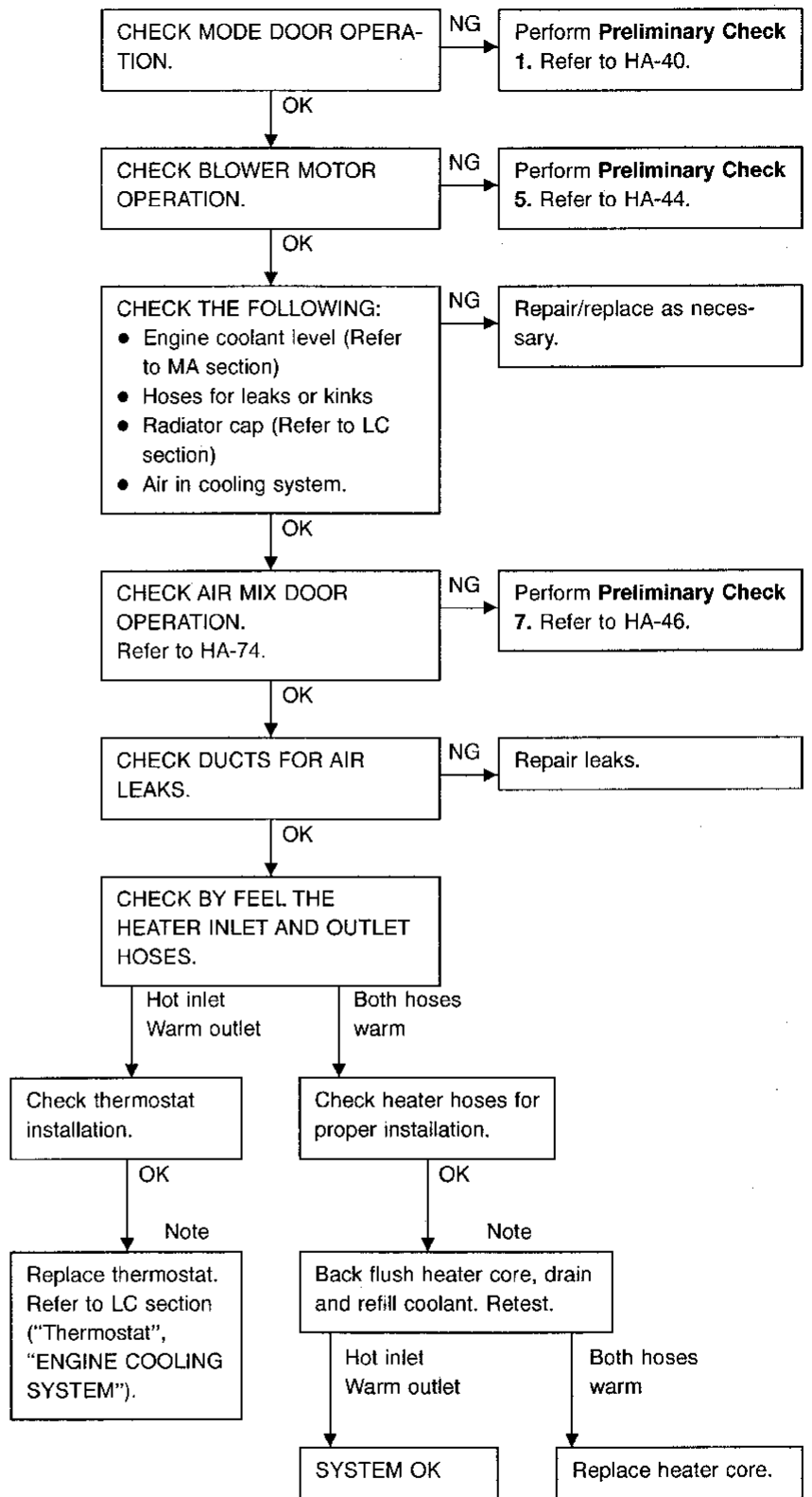

Note: To avoid unnecessary service of heating system, first perform TEMPERATURE SETTING TRIMMING. Refer to "AUXILIARY MECHANISM", "Self-diagnosis". (HA-39)

GI
MA
EM
LC
EC
FE
CL
MT
AT
FA
RA
BR
ST
RS
BT
HA
EL
IDX

TROUBLE DIAGNOSES

Preliminary Check (Cont'd)

PRELIMINARY CHECK 5

Blower motor operation is malfunctioning.

- Perform Self-diagnosis STEP 1 before referring to the following flow chart.

CHECK SENSOR CIRCUIT.
Set up Self-diagnosis STEP 2.
Is each sensor circuit normal?
Code No. 20 should be indicated on the display after approx. 3 seconds.

No → CHECK SENSOR CIRCUIT IN DETAIL ACCORDING TO THE DIAGNOSTIC PROCEDURE BELOW CORRESPONDING TO EACH CODE NO.

Code No.	How to repair	Reference page
21	Go to Diagnostic Procedure 1.	HA-61
22	Go to Diagnostic Procedure 2.	HA-62
24	Go to Diagnostic Procedure 3.	HA-63
25	Go to Diagnostic Procedure 4.	HA-64
26	Go to Diagnostic Procedure 5.	HA-65
-21	Go to Diagnostic Procedure 1.	HA-61
-22	Go to Diagnostic Procedure 2.	HA-62
-24	Go to Diagnostic Procedure 3.	HA-63
-25	Go to Diagnostic Procedure 4.	HA-64
-26	Go to Diagnostic Procedure 5.	HA-65

Are sensor circuits for ambient sensor and in-vehicle sensor operating normally? If malfunction is suspected, check temperature detected by each sensor using Self-diagnosis STEP 5. Confirm the temperature is within normal range before performing Diagnostic Procedures.

Yes ↓

CHECK BLOWER MOTOR OPERATION.
Set up Self-diagnosis STEP 4.
Does blower speed change according to each code No.?

Code No.	41	42	43	44	45	46
Blower motor speed	Low	Middle high	Middle low		High	

No → Go to **Diagnostic Procedure 8.** (HA-69)

Yes ↓

Is engine coolant temperature below 50°C (122°F) and ambient temperature below 15°C (59°F)?

No → Blower motor operation is normal. Refer to **Fan speed control specification.** (HA-86)

Yes ↓

IS BLOWER MOTOR CONTROLLED UNDER STARTING FAN SPEED CONTROL?
Refer to **Starting fan speed control.** (HA-86)

No → Check thermal transmitter. Refer to EL section.

Yes ↓

Blower motor operation is normal.

TROUBLE DIAGNOSES

Preliminary Check (Cont'd)

PRELIMINARY CHECK 6

Magnet clutch does not engage.

Perform Self-diagnosis STEP 1 before referring to the following flow chart.

CHECK SENSOR CIRCUIT.
Set up Self-diagnosis STEP 2.
Is each sensor circuit normal?
Code No. 20 should be indicated on the display after approx. 3 seconds.

No → CHECK SENSOR CIRCUIT IN DETAIL ACCORDING TO THE DIAGNOSTIC PROCEDURE BELOW CORRESPONDED TO EACH CODE NO.

Code No.	How to repair	Reference page
21	Go to Diagnostic Procedure 1.	HA-61
22	Go to Diagnostic Procedure 2.	HA-62
24	Go to Diagnostic Procedure 3.	HA-63
25	Go to Diagnostic Procedure 4.	HA-64
26	Go to Diagnostic Procedure 5.	HA-65
-21	Go to Diagnostic Procedure 1.	HA-61
-22	Go to Diagnostic Procedure 2.	HA-62
-24	Go to Diagnostic Procedure 3.	HA-63
-25	Go to Diagnostic Procedure 4.	HA-64
-26	Go to Diagnostic Procedure 5.	HA-65

Are sensor circuits for ambient sensor and in-vehicle sensor operating normally? If malfunction is suspected, check temperature detected by each sensor using Self-diagnosis STEP 5. Confirm the temperature is within normal range before performing Diagnostic Procedures.

Yes

CHECK MAGNET CLUTCH OPERATION.
Set up Self-diagnosis STEP 4.
Does magnet clutch operate according to each code No.?

Code No.	41	42	43	44	45	46
Actuator						
Compressor	ON	ON	ON	OFF	OFF	ON

No → CHECK REFRIGERANT.
Connect manifold gauge, then check system pressure.

NG → Check refrigerant leaks.

OK

Go to Diagnostic Procedure 9. (HA-71)

Yes

Magnet clutch control system is normal.
Refer to MAGNET CLUTCH CONTROL. (HA-87)

GI
MA
EM
LC
EC
FE
CL
MT
AT
FA
RA
BR
ST
RS
BT
HA
EL
IDX

TROUBLE DIAGNOSES

Preliminary Check (Cont'd)

PRELIMINARY CHECK 7

Discharged air temperature does not change.

Perform Self-diagnosis STEP 1 before referring to the following flow chart.

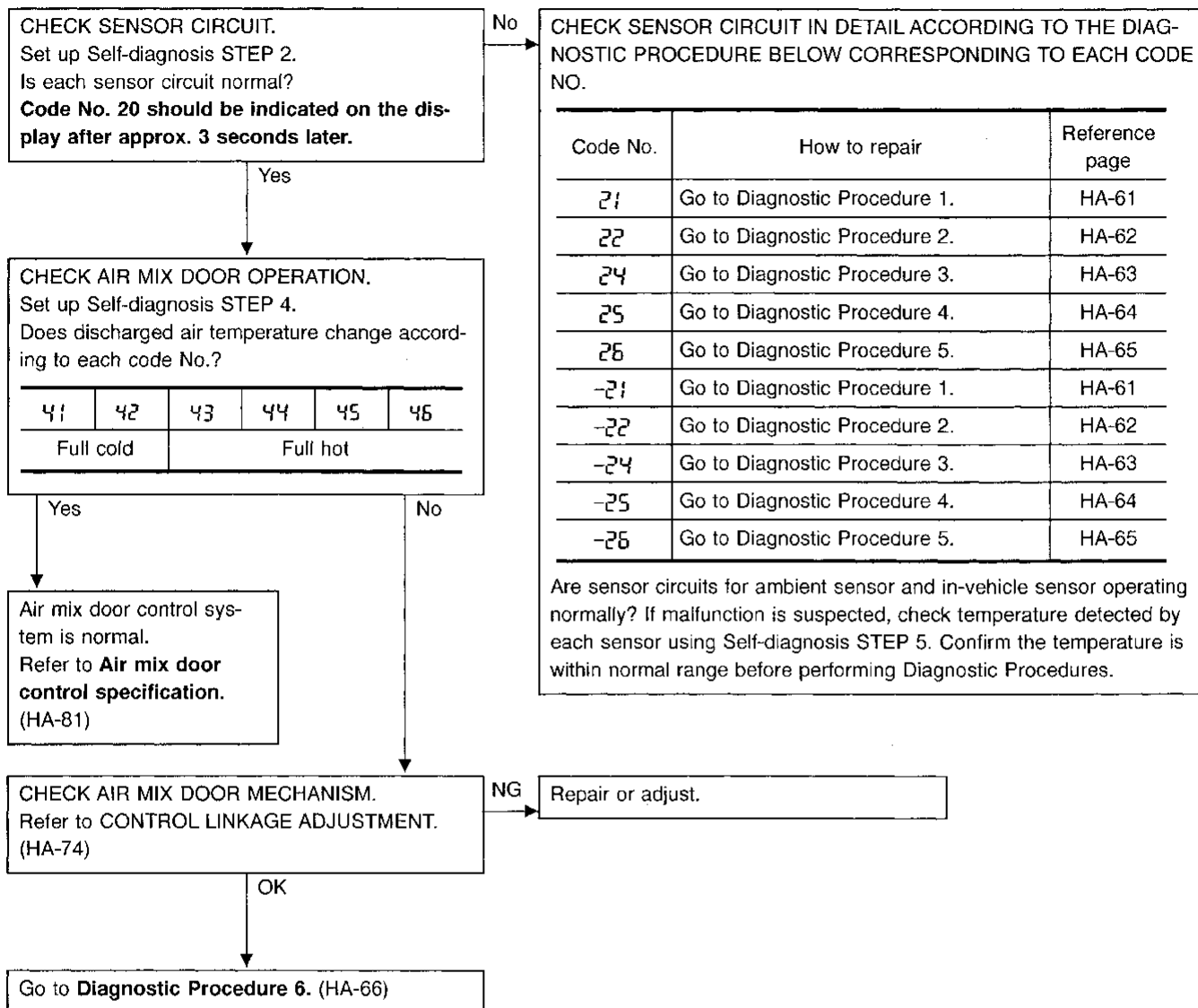

TROUBLE DIAGNOSES

Preliminary Check (Cont'd)

PRELIMINARY CHECK 8

Noise

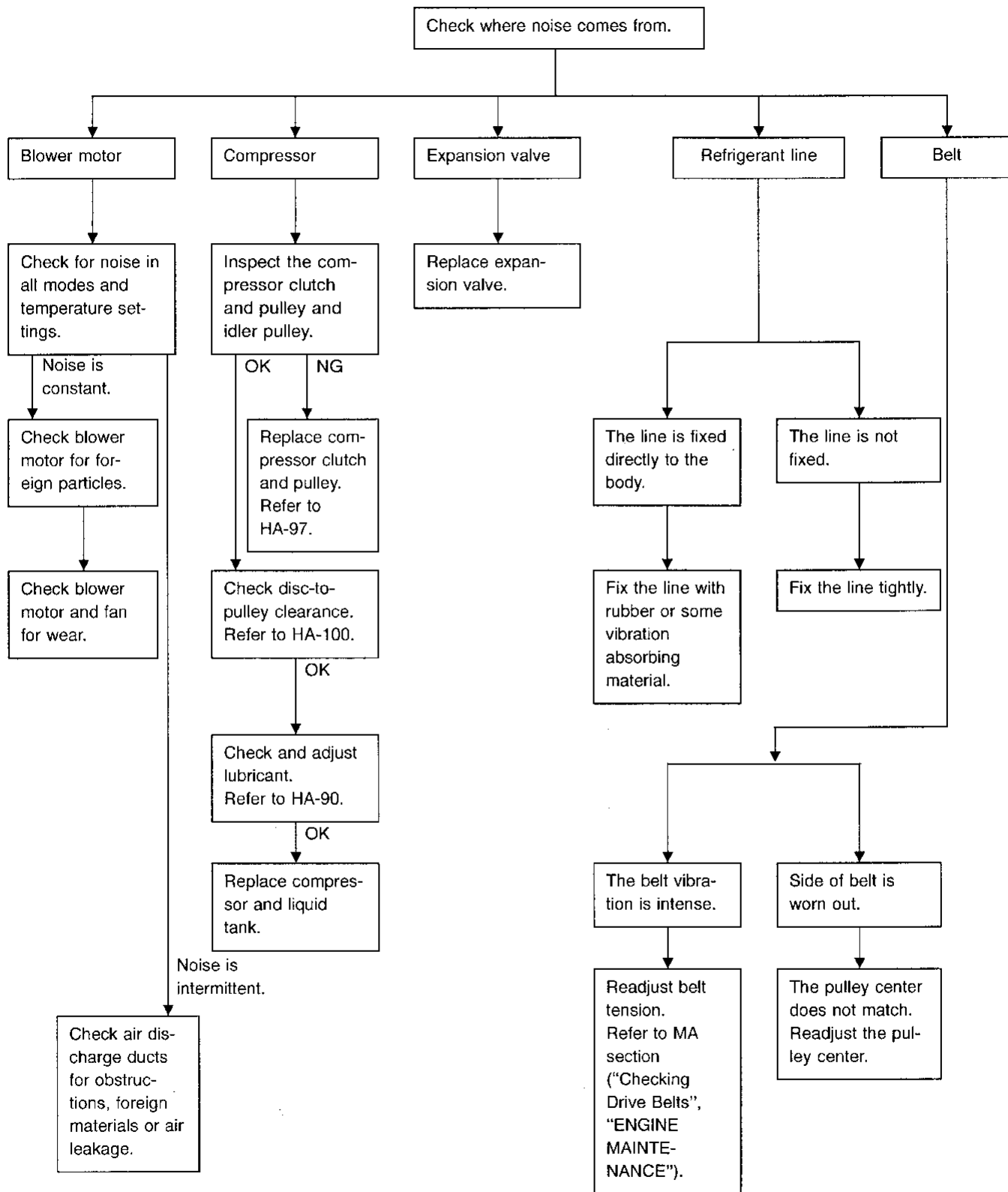

GI
MA
EM
LC
EC
FE
CL
MT
AT
FA
RA
BR
ST
RS
BT
HA
EL
IDX

TROUBLE DIAGNOSES

Performance Test Diagnoses

INSUFFICIENT COOLING

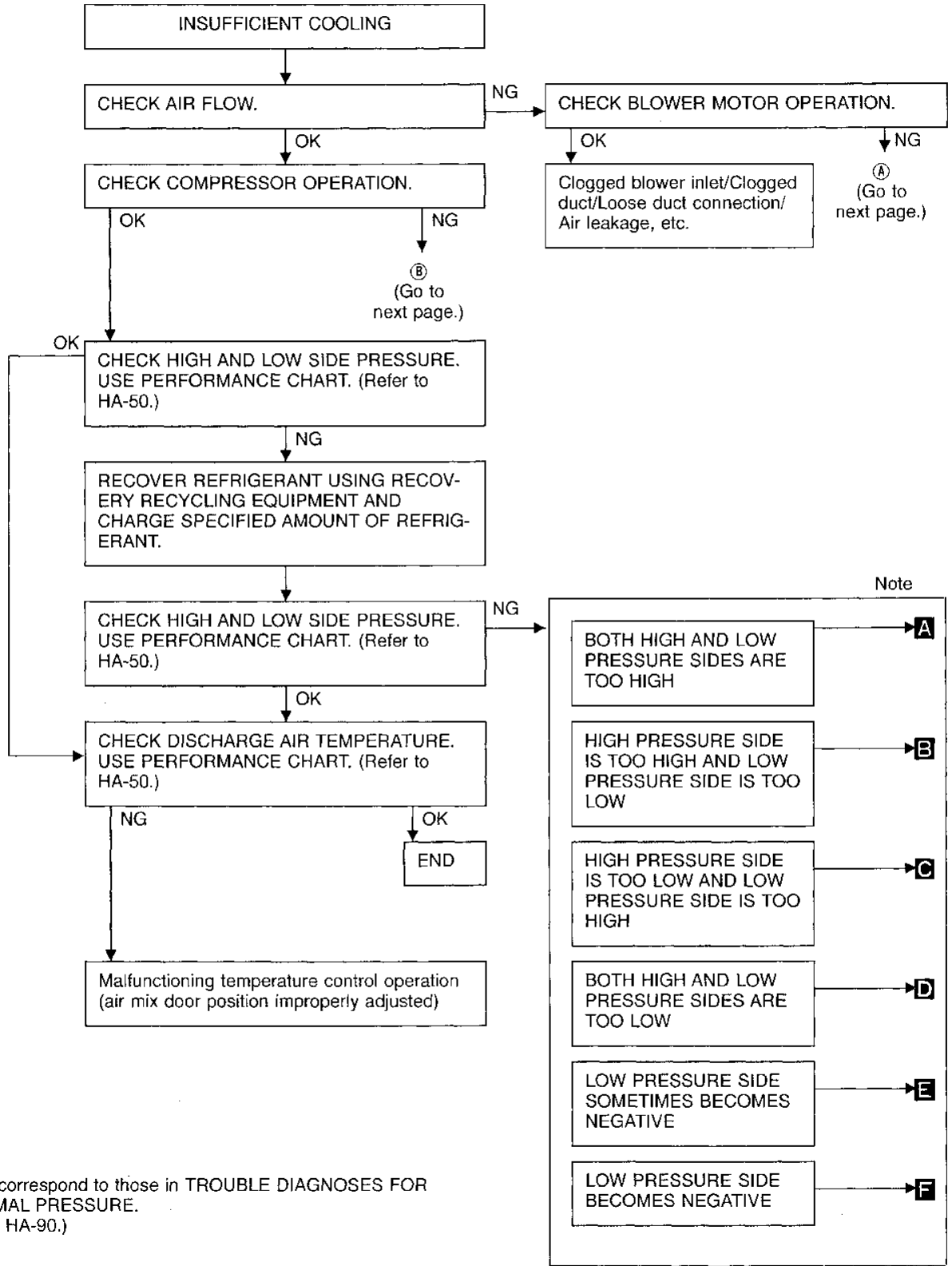

Note: **A - F** correspond to those in TROUBLE DIAGNOSES FOR ABNORMAL PRESSURE. (Refer to HA-90.)

TROUBLE DIAGNOSES

Performance Test Diagnoses (Cont'd)

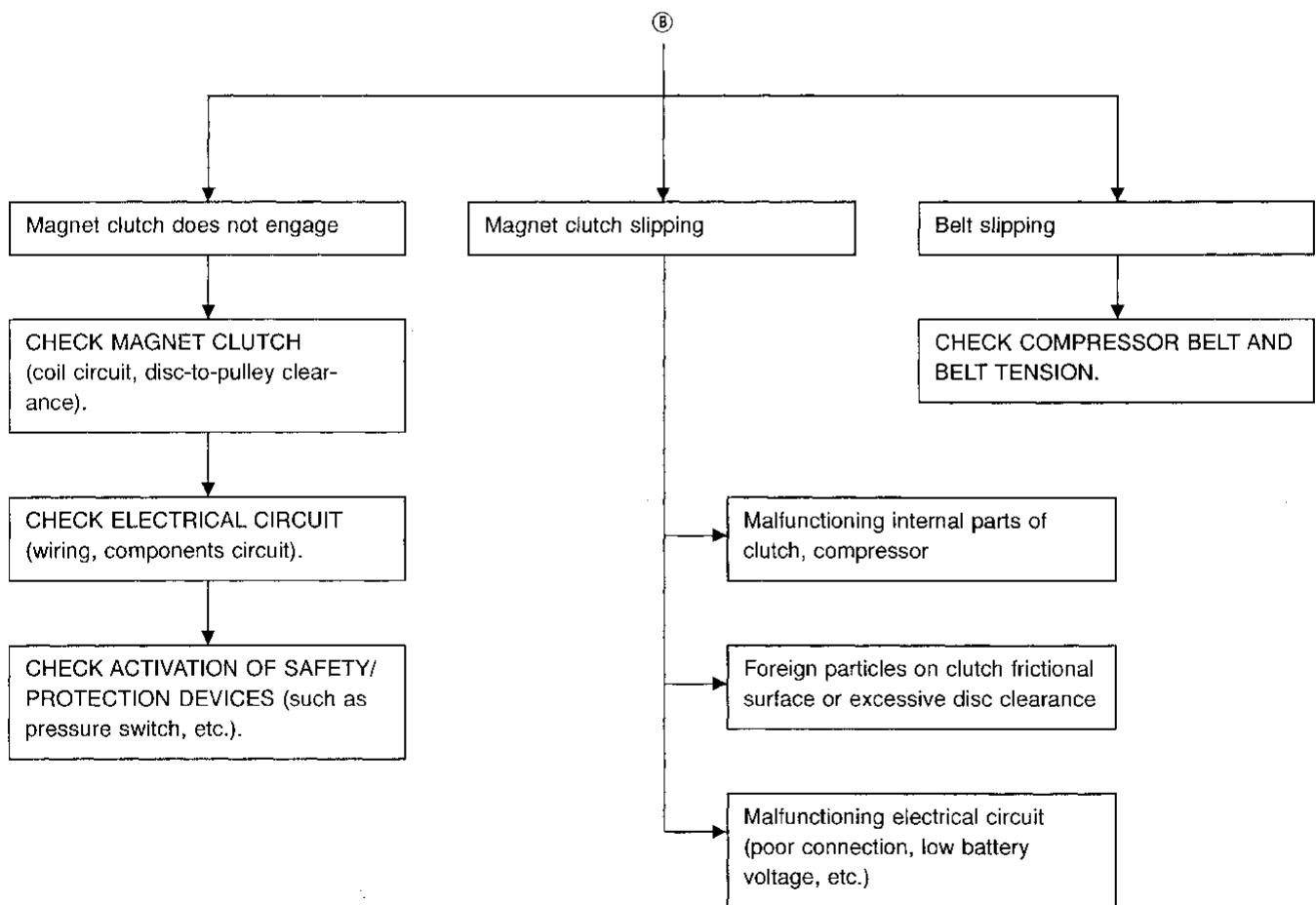
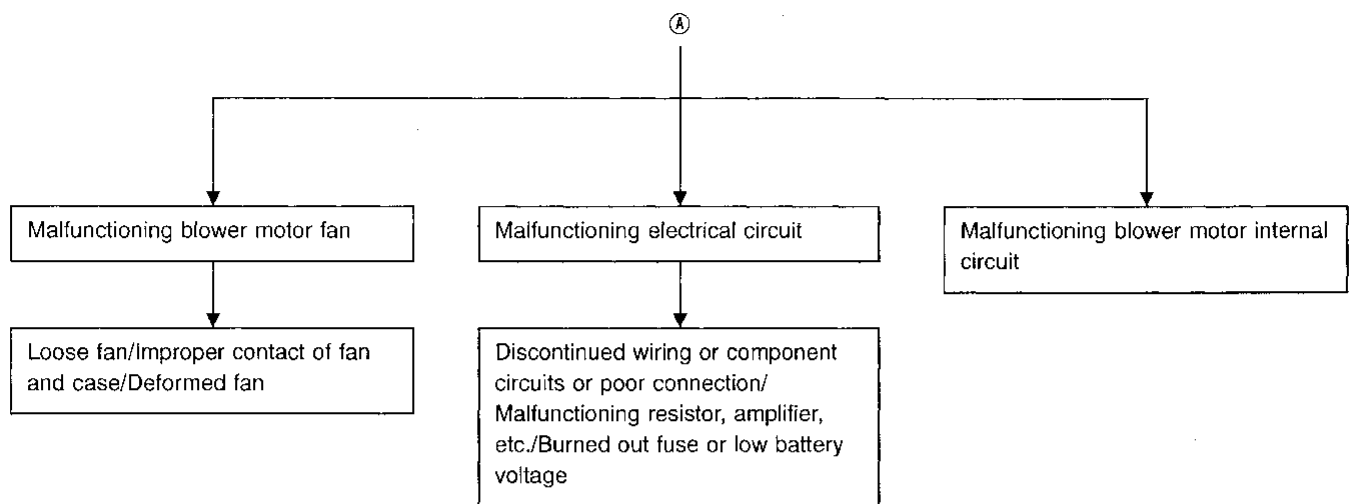

GI

MA

EM

LC

EC

FE

CL

MT

AT

FA

RA

BR

ST

RS

BT

HA

EL

IDX

TROUBLE DIAGNOSES

Performance Chart

TEST CONDITION

Testing must be performed as follows:

Vehicle location: Indoors or in the shade (in a well ventilated place)

Doors: Closed

Door window: Open

Hood: Open

TEMP. setting: Max. COLD

Discharge Air: Face Vent

RECIRC switch: (Recirculation) ON

FAN speed: 4-speed

A/C switch: ON

Engine speed: 1,500 rpm

Operate the air conditioning system for 10 minutes before taking measurements.

TEST READING

Recirculating-to-discharge air temperature table

Inside air (Recirculating air) at blower assembly inlet		Discharge air temperature at center vent-lator °C (°F)
Relative humidity %	Air temperature °C (°F)	
50 - 60	20 (68)	1.5 - 2.6 (35 - 37)
	25 (77)	3.7 - 5.7 (39 - 42)
	30 (86)	7.6 - 10.0 (46 - 50)
	35 (95)	12.4 - 15.2 (54 - 59)
60 - 70	20 (68)	2.6 - 3.6 (37 - 38)
	25 (77)	5.7 - 7.6 (42 - 46)
	30 (86)	10.0 - 12.4 (50 - 54)
	35 (95)	15.2 - 18.0 (59 - 64)

Ambient air temperature-to-operating pressure table

Ambient air		High-pressure (Discharge side) kPa (kg/cm ² , psi)	Low-pressure (Suction side) kPa (kg/cm ² , psi)
Relative humidity %	Air temperature °C (°F)		
50 - 70	20 (68)	785 - 1,040 (8.0 - 10.6, 114 - 151)	137 - 167 (1.4 - 1.7, 20 - 24)
	25 (77)	981 - 1,304 (10.0 - 13.3, 142 - 189)	137 - 167 (1.4 - 1.7, 20 - 24)
	30 (86)	1,167 - 1,550 (11.9 - 15.8, 169 - 225)	147 - 177 (1.5 - 1.8, 21 - 26)
	35 (95)	1,373 - 1,804 (14.0 - 18.4, 199 - 262)	157 - 186 (1.6 - 1.9, 23 - 27)
	40 (104)	1,550 - 2,059 (15.8 - 21.0, 225 - 299)	167 - 206 (1.7 - 2.1, 24 - 30)

If pressure is not within range, refer to HA-51, "Trouble Diagnoses for Abnormal Pressure".

TROUBLE DIAGNOSES

Trouble Diagnoses for Abnormal Pressure

Whenever system's high or low side pressure is abnormal, diagnose using a manifold gauge. The marker above the gauge scale in the following tables indicates the standard (normal) pressure range. Since the standard (normal) pressure, however, differs from vehicle to vehicle, refer to HA-50 ("Ambient air temperature-to-operating pressure table").

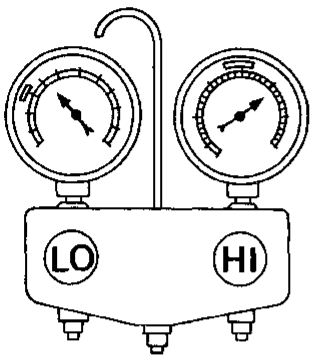
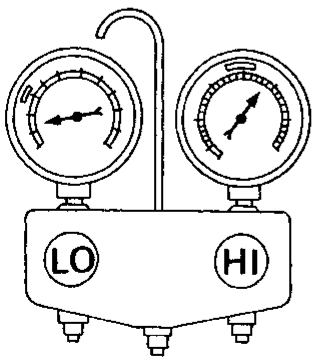
Gauge indication	Refrigerant cycle	Probable cause	Corrective action
<p>Both high and low-pressure sides are too high.</p> <p>A</p>  <p>AC359A</p>	<ul style="list-style-type: none"> Pressure is reduced soon after water is splashed on condenser. 	<p>Excessive refrigerant charge in refrigeration cycle</p>	<p>Reduce refrigerant until specified pressure is obtained.</p>
	<p>Air suction by cooling fan is insufficient.</p>	<p>Insufficient condenser cooling performance</p> <p>↓</p> <p>① Condenser fins are clogged. ② Improper fan rotation of cooling fan</p>	<ul style="list-style-type: none"> Clean condenser. Check and repair cooling fan as necessary.
	<ul style="list-style-type: none"> Low-pressure pipe is not cold. When compressor is stopped high-pressure value quickly drops by approximately 196 kPa (2 kg/cm², 28 psi). It then decreases gradually thereafter. 	<p>Poor heat exchange in condenser (After compressor operation stops, high pressure decreases too slowly.)</p> <p>↓</p> <p>Air in refrigeration cycle</p>	<p>Evacuate repeatedly and recharge system.</p>
	<p>Engine tends to overheat.</p>	<p>Engine cooling systems malfunction.</p>	<p>Check and repair each engine cooling system.</p>
	<ul style="list-style-type: none"> An area of the low-pressure pipe is colder than areas near the evaporator outlet. Plates are sometimes covered with frost. 	<ul style="list-style-type: none"> Excessive liquid refrigerant on low-pressure side Excessive refrigerant discharge flow Expansion valve is open a little compared with the specification. <p>↓</p> <p>① Improper thermal valve installation ② Improper expansion valve adjustment</p>	<p>Replace expansion valve.</p>
<p>High-pressure side is too high and low-pressure side is too low.</p> <p>B</p>  <p>AC360A</p>	<p>Upper side of condenser and high-pressure side are hot, however, liquid tank is not so hot.</p>	<p>High-pressure tube or parts located between compressor and condenser are clogged or hot.</p>	<ul style="list-style-type: none"> Check and repair or replace malfunctioning parts. Check lubricant for contamination.

GI

MA

EM

LC

EC

FE

CL

MT

AT

FA

RA

BR

ST

RS

BT

HA

EL

IDX

TROUBLE DIAGNOSES

Trouble Diagnoses for Abnormal Pressure (Cont'd)

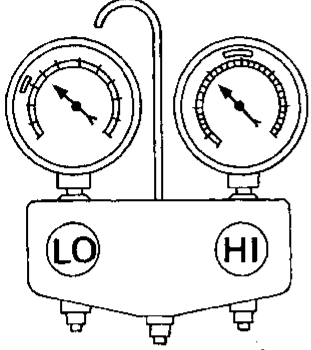
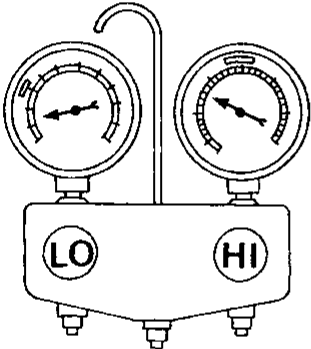
Gauge indication	Refrigerant cycle	Probable cause	Corrective action
High-pressure side is too low and low-pressure side is too high. C  AC356A	High and low-pressure sides become equal soon after compressor operation stops.	Compressor pressure operation is improper. ↓ Damaged inside compressor packings	Replace compressor.
	No temperature difference between high and low-pressure sides	Compressor discharge capacity does not change. (Compressor stroke is set at maximum.)	Replace compressor.
Both high- and low-pressure sides are too low. D  AC353A	<ul style="list-style-type: none"> • There is a big temperature difference between liquid tank outlet and inlet. Outlet temperature is extremely low. • Liquid tank inlet and expansion valve are frosted. 	Liquid tank inside is clogged a little.	<ul style="list-style-type: none"> • Replace liquid tank. • Check lubricant for contamination.
	<ul style="list-style-type: none"> • Temperature of expansion valve inlet is extremely low as compared with areas near liquid tank. • Expansion valve inlet may be frosted. • Temperature difference occurs somewhere in high-pressure side 	High-pressure pipe located between liquid tank and expansion valve is clogged.	<ul style="list-style-type: none"> • Check and repair malfunctioning parts. • Check lubricant for contamination.
	Expansion valve and liquid tank are warm or only cool to the touch.	Low refrigerant charge. ↓ Leaking fittings or components.	<ul style="list-style-type: none"> • Check for refrigerant leaks. Refer to "Checking Refrigerant Leaks", HA-93.
	There is a big temperature difference between expansion valve inlet and outlet while the valve itself is frosted.	Expansion valve closes a little compared with the specification. ↓ ① Improper expansion valve adjustment ② Malfunctioning thermal valve ③ Outlet and inlet may be clogged.	<ul style="list-style-type: none"> • Remove foreign particles by using compressed air. • Check lubricant for contamination.
	An area of the low-pressure pipe is colder than areas near the evaporator outlet.	Low-pressure pipe is clogged or crushed.	<ul style="list-style-type: none"> • Check and repair malfunctioning parts. • Check lubricant for contamination.
	Air flow volume is not enough or is too low.	Evaporator is frozen. ↓ Compressor discharge capacity does not change. (Compressor stroke is set at maximum length.)	Replace compressor.

TROUBLE DIAGNOSES

Trouble Diagnoses for Abnormal Pressure (Cont'd)

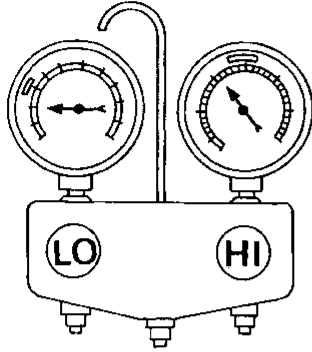
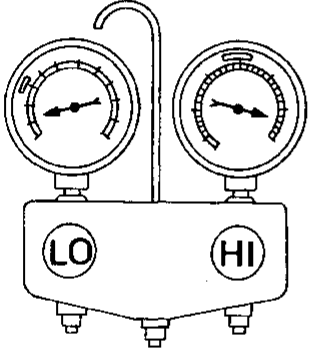
Gauge indication	Refrigerant cycle	Probable cause	Corrective action
<p>Low-pressure side sometimes becomes negative.</p> <p>E</p>  <p>AC354A</p>	<ul style="list-style-type: none"> • Air conditioning system does not function and does not cyclically cool the compartment air. • The system constantly functions for a certain period of time after compressor is stopped and restarted. 	<p>Refrigerant does not discharge cyclically.</p> <p style="text-align: center;">↓</p> <p>Moisture is frozen at expansion valve outlet and inlet.</p> <p style="text-align: center;">↓</p> <p>Water is mixed with refrigerant.</p>	<ul style="list-style-type: none"> • Drain water from refrigerant or replace refrigerant. • Replace liquid tank.
<p>Low-pressure side becomes negative.</p> <p>F</p>  <p>AC362A</p>	<p>Liquid tank or front/rear side of expansion valve's pipe is frosted or dewed.</p>	<p>High-pressure side is closed and refrigerant does not flow.</p> <p style="text-align: center;">↓</p> <p>Expansion valve or liquid tank is frosted.</p>	<p>Leave the system at rest until no frost is present. Start it again to check whether or not the problem is caused by water or foreign particles.</p> <ul style="list-style-type: none"> • If water is the cause, initially cooling is okay. Then the water freezes causing a blockage. Drain water from refrigerant or replace refrigerant. • If due to foreign particles, remove expansion valve and remove particles with dry and compressed air (not shop air). • If either of the above methods cannot correct the problem, replace expansion valve. • Replace liquid tank. • Check lubricant for contamination.

GI

MA

EM

LC

EC

FE

CL

MT

AT

FA

RA

BR

ST

RS

BT

HA

EL

IDX

Harness Layout

ENGINE COMPARTMENT

A Relay box-1

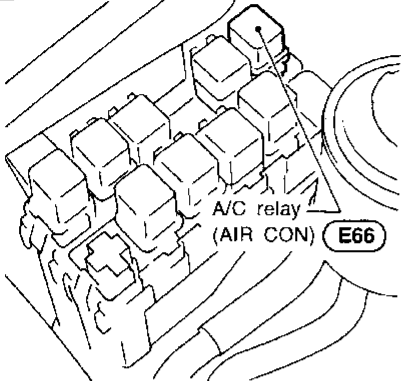

B Fuse block

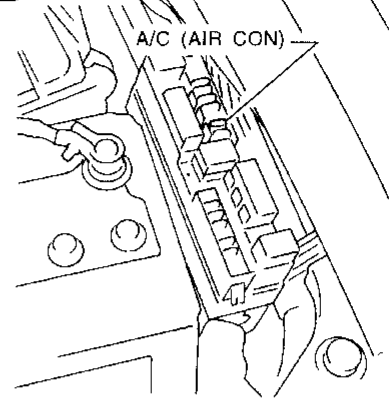

C Ambient sensor

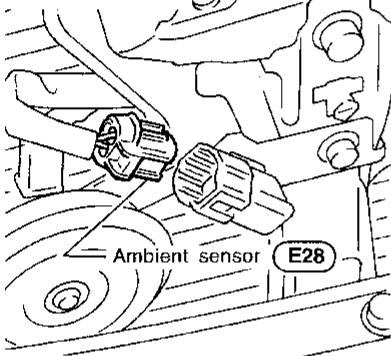

F Compressor

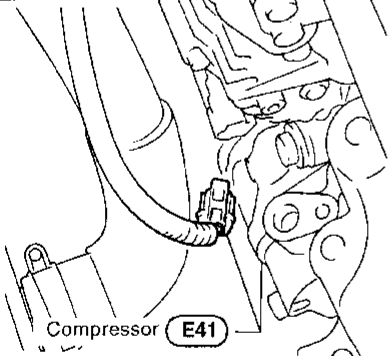

E Cooling fan motor

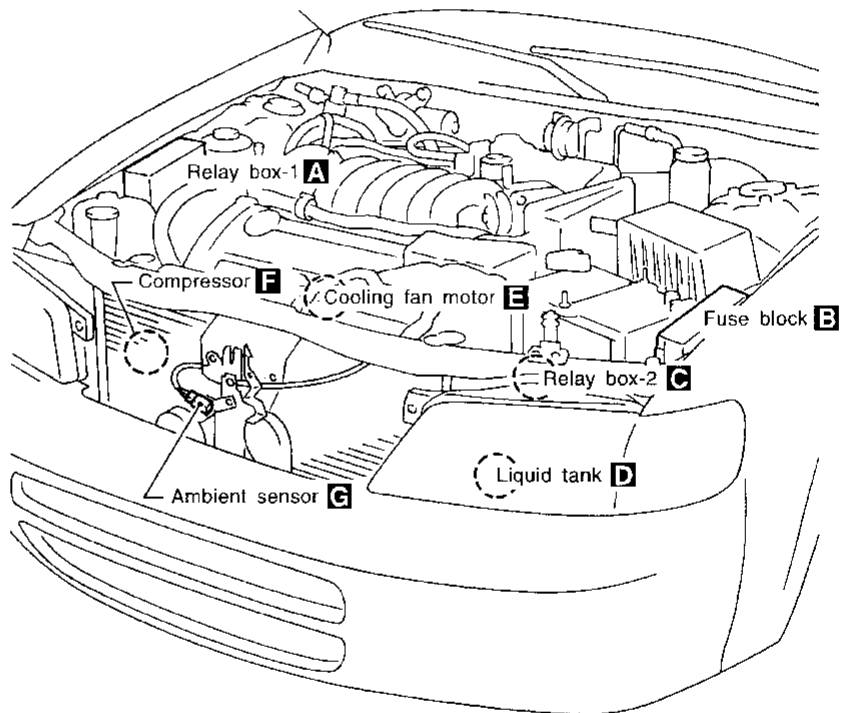
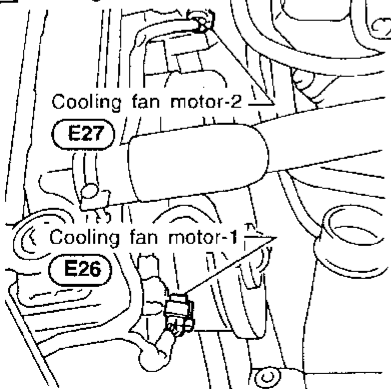

D Liquid tank

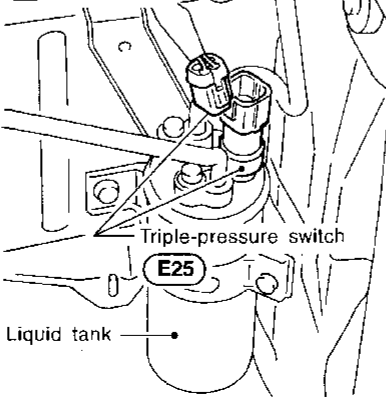

C Relay box-2

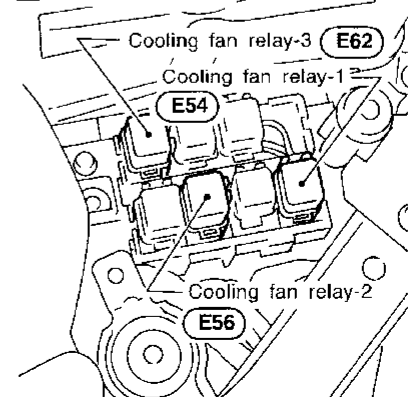

TROUBLE DIAGNOSES

Harness Layout (Cont'd)

PASSENGER COMPARTMENT

A Control unit

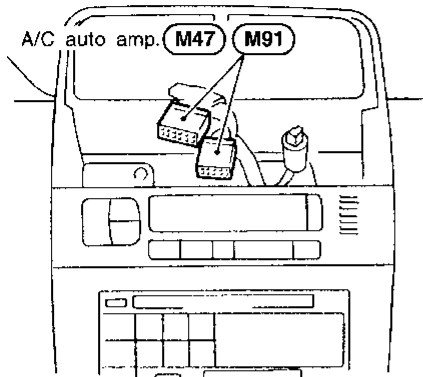

B Mode door motor

Mode door motor **M38**

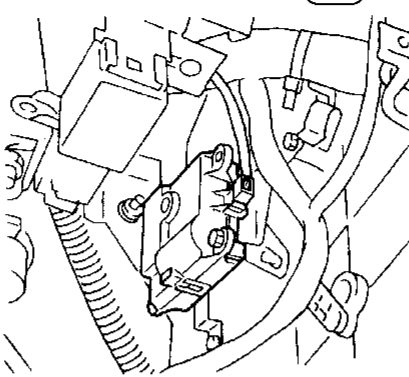

C Sunload sensor

Defroster grille RH

Sunload sensor **M64**

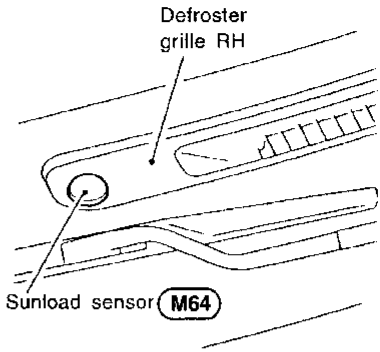

A/C auto amp. **A** **M47** **M91**

In-vehicle sensor **F** **M41**

Mode door motor **B** **M38**

Sunload sensor **C** **M64**

Intake door motor **D** **M69**

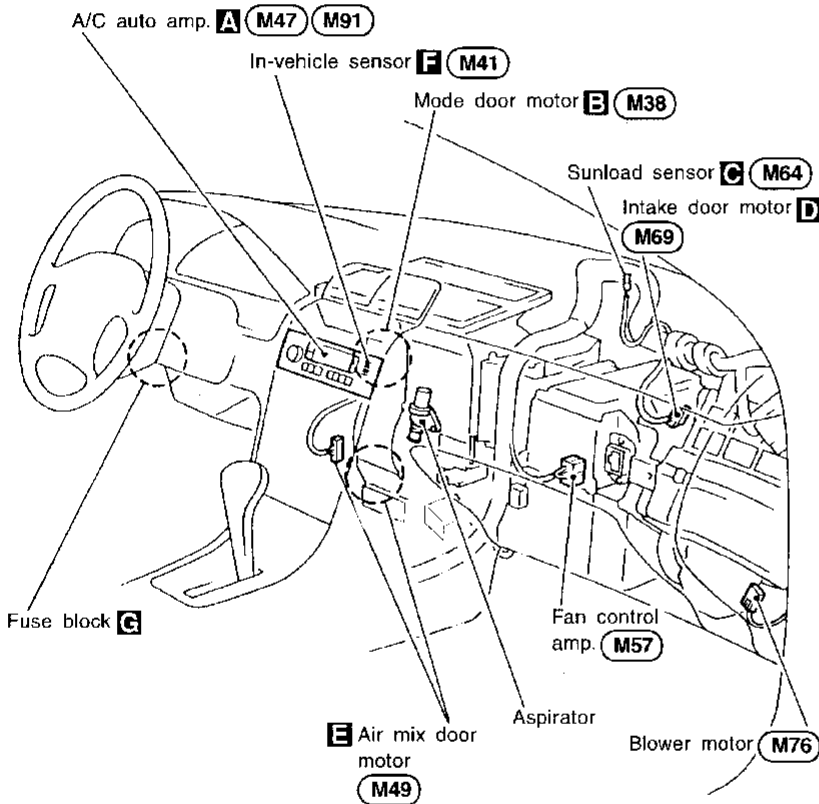

D Intake door motor

Intake door motor **M69**

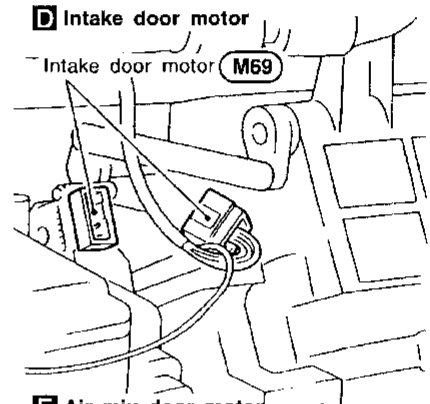

E Air mix door motor

Air mix door motor

Sub-harness

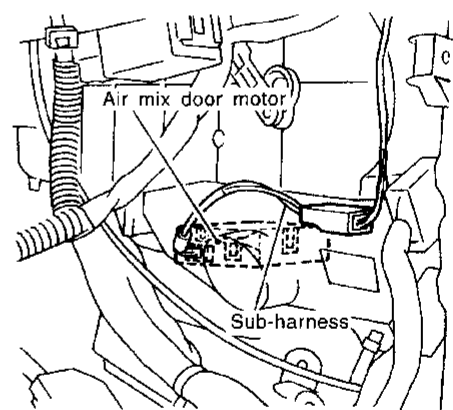

C Fuse block

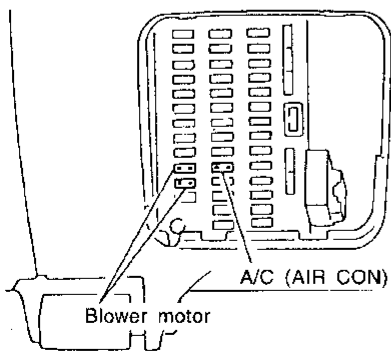

F In-vehicle sensor

Instrument finisher

In-vehicle sensor **M41**

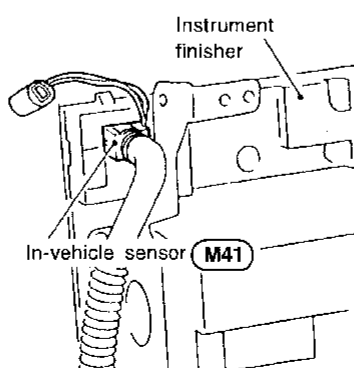

GI

MA

EM

LC

EC

FE

CL

MT

AT

FA

RA

BR

ST

RS

BT

HA

EL

IDX

Circuit Diagram

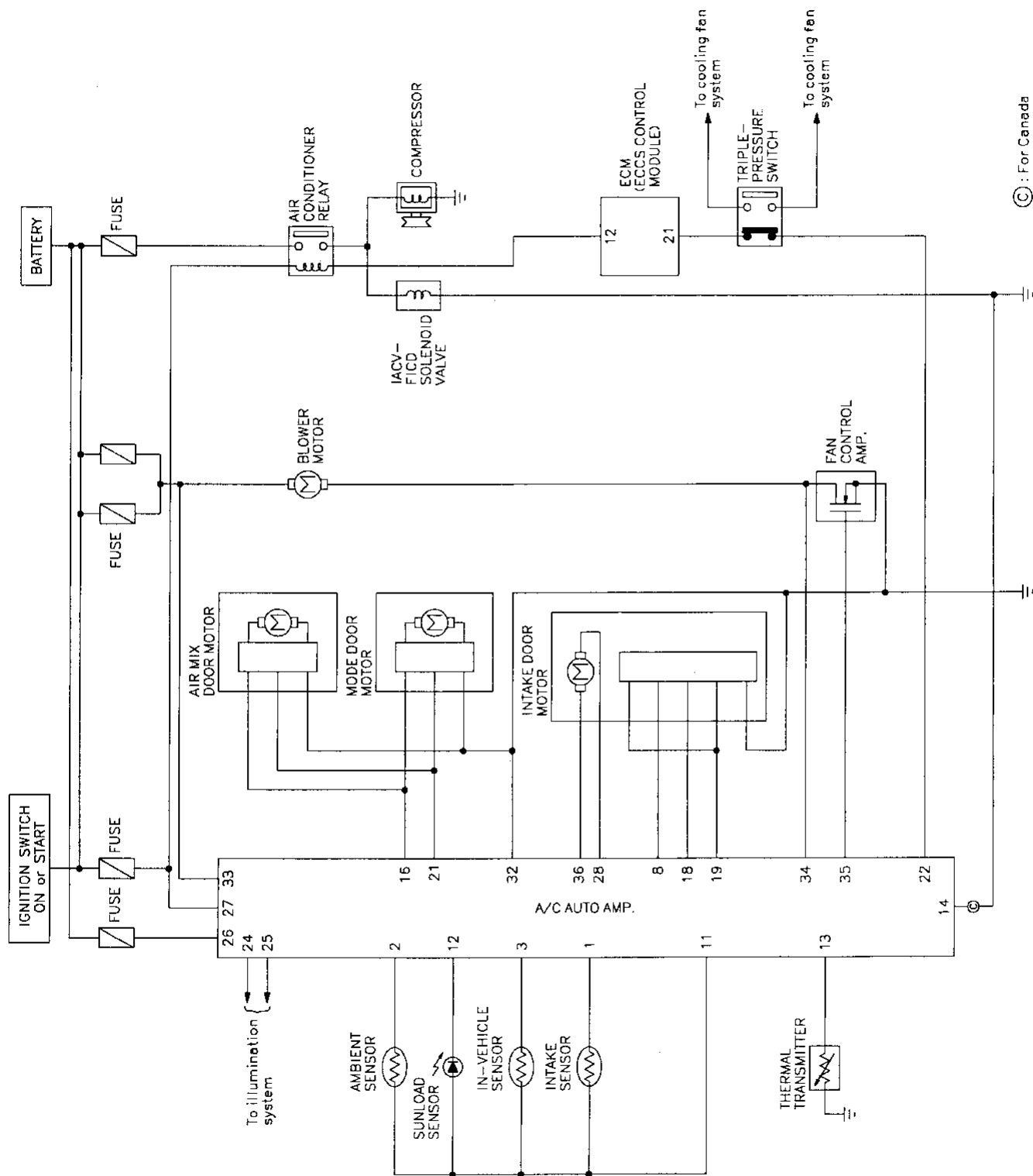

© : For Canada

TROUBLE DIAGNOSES

Wiring Diagram — A/C, A —

HA-A/C,A-01

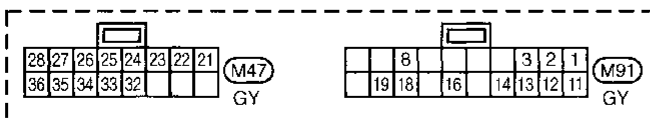
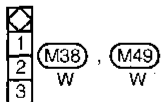
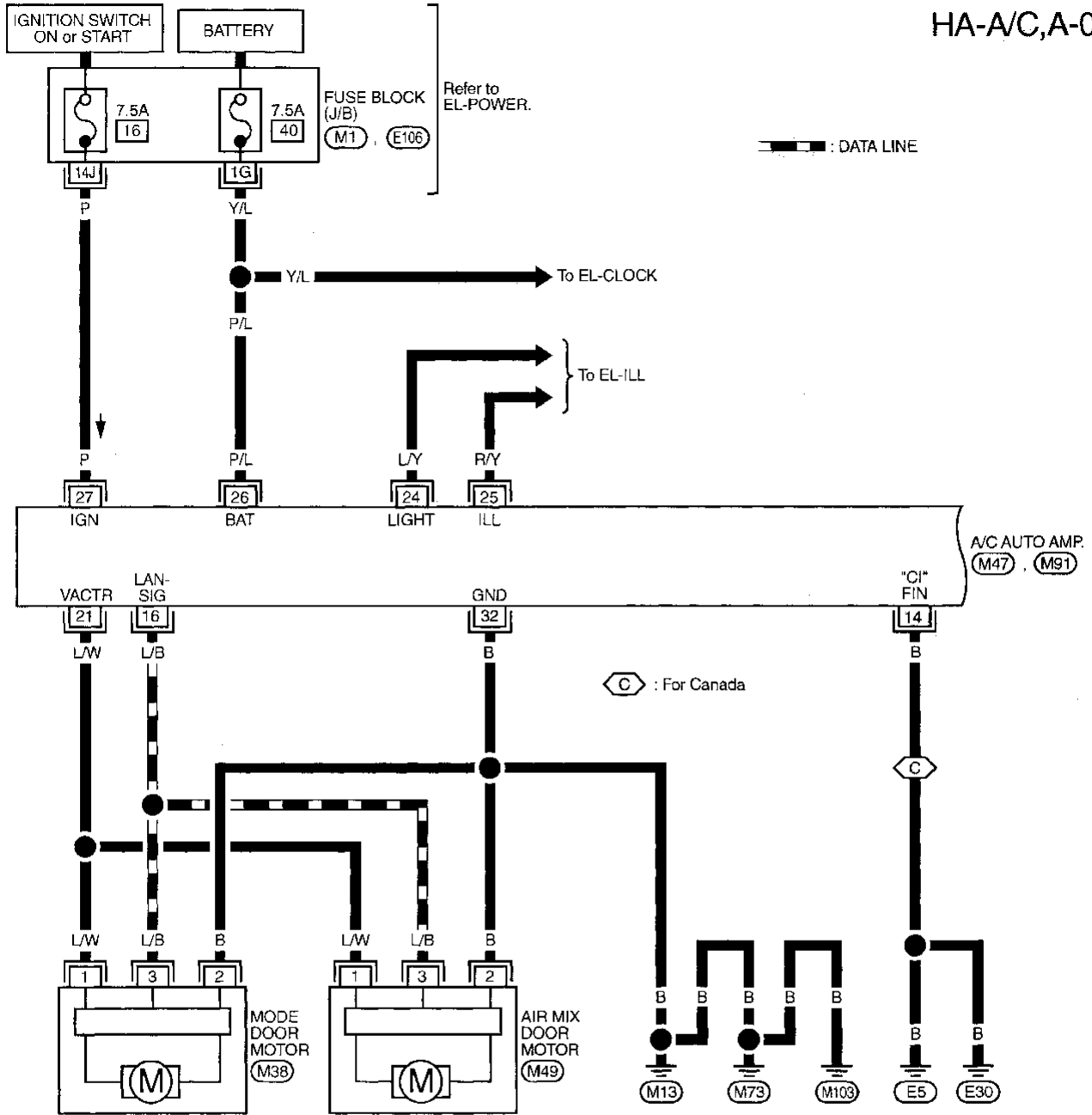

Refer to last page (Foldout page).

M1
E106

GI
MA
EM
LC
EC
FE
CL
MT
AT
FA
RA
BR
ST
RS
BT
HA
EL
IDX

TROUBLE DIAGNOSES

Wiring Diagram — A/C, A — (Cont'd)

HA-A/C,A-02

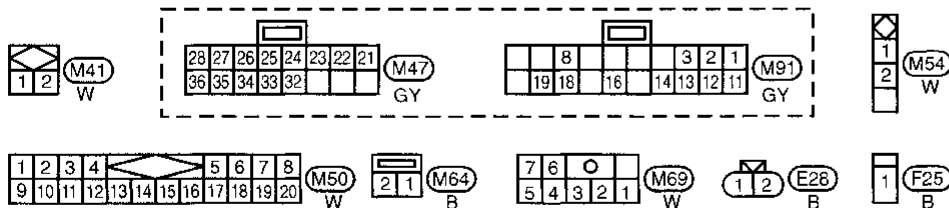
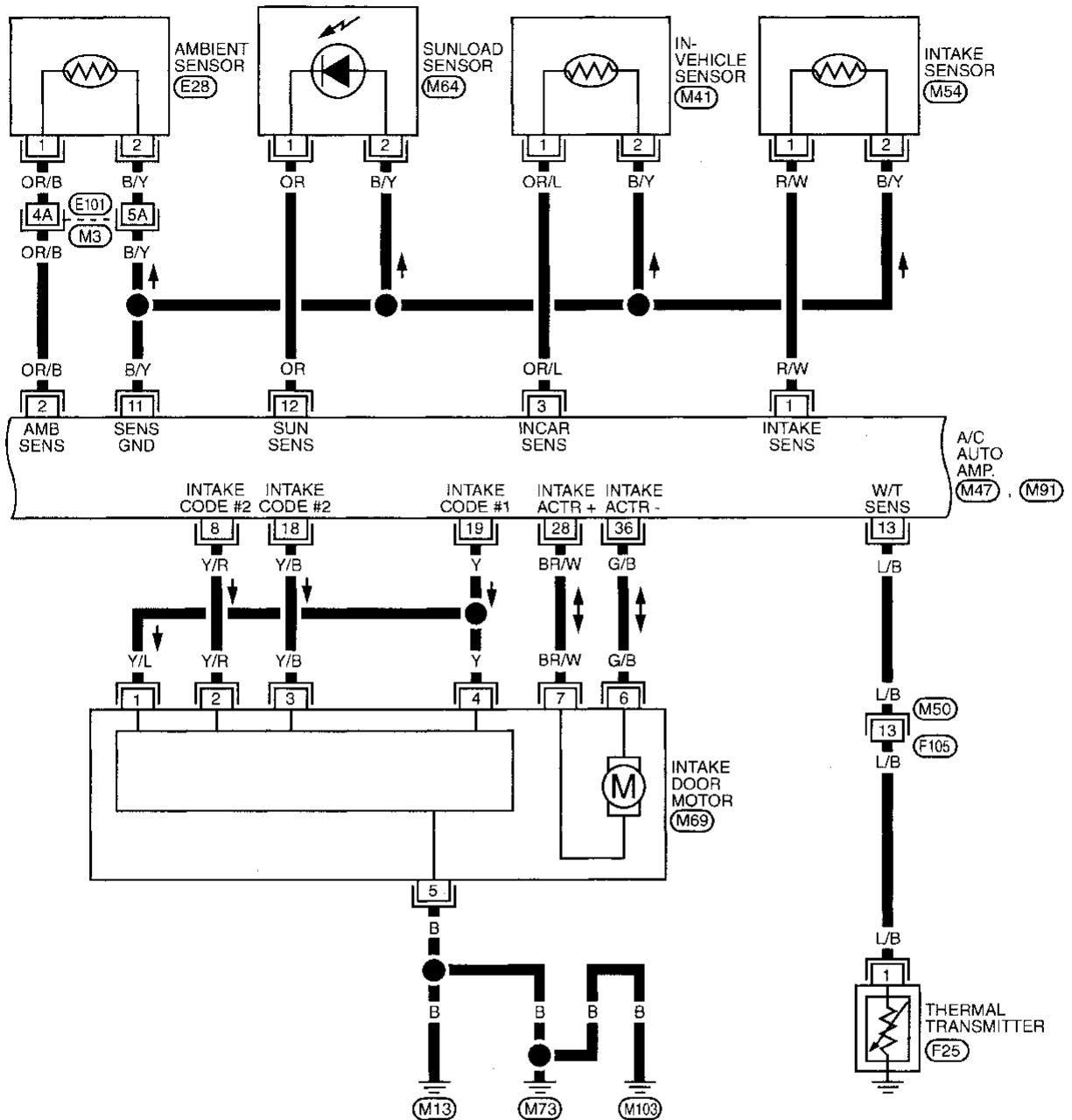

Refer to last page (Foldout page).
M3, E101

TROUBLE DIAGNOSES

Wiring Diagram — A/C, A — (Cont'd)

HA-A/C,A-03

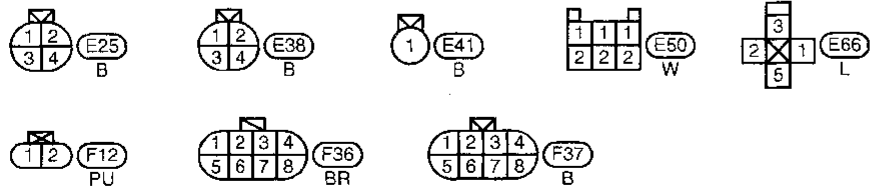
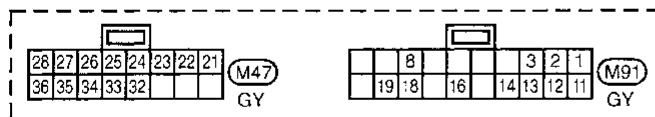
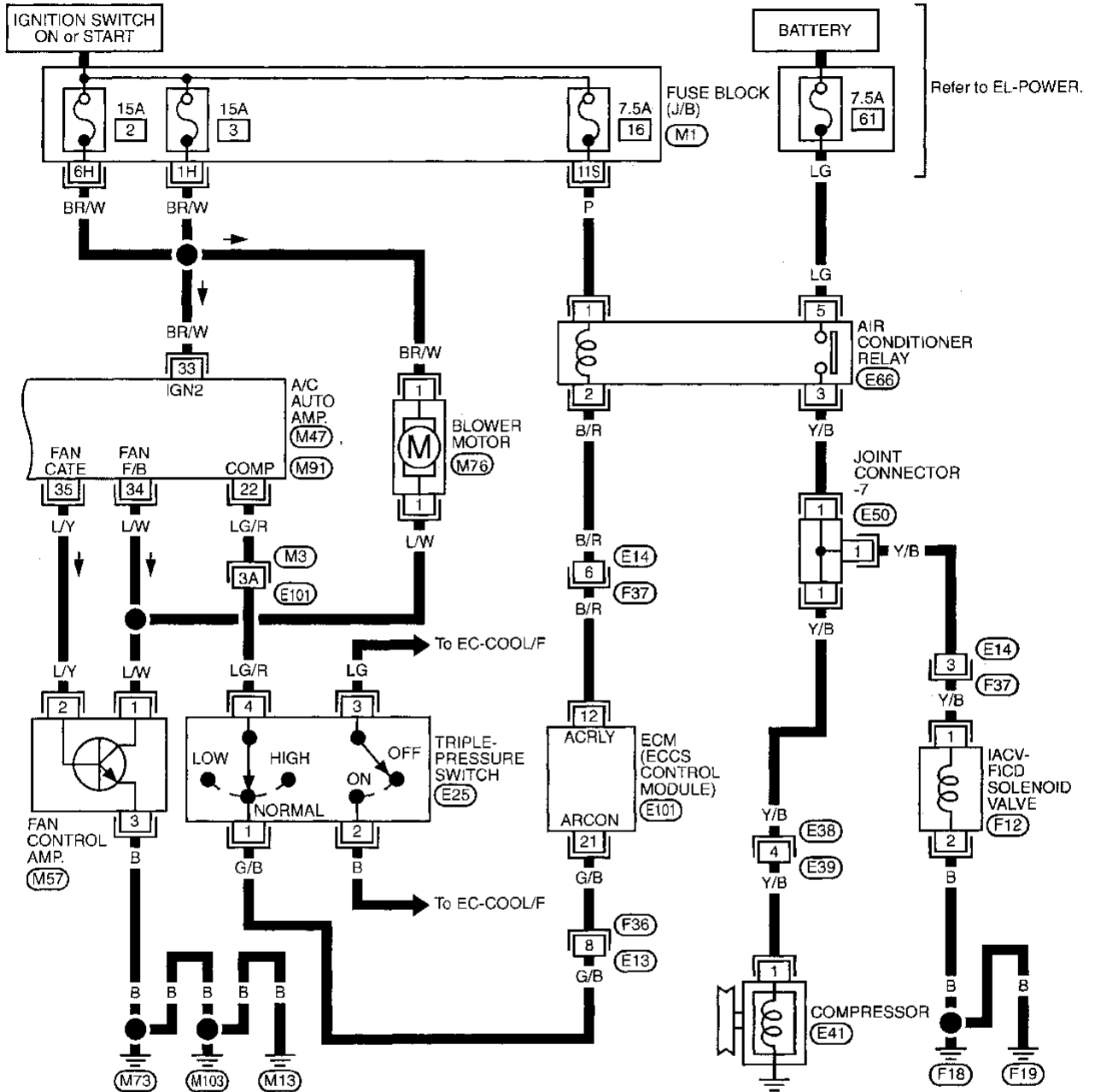

Refer to last page (Foldout page).

- (M1)
- (M3) (E101)
- (F101)

GI
MA
EM
LC
EC
FE
CL
MT
AT
FA
RA
BR
ST
RS

BT

HA

EL

IDX

TROUBLE DIAGNOSES

Main Power Supply and Ground Circuit Check POWER SUPPLY CIRCUIT CHECK FOR AUTO A/C SYSTEM

Check power supply circuit for auto air conditioning system.
Refer to "POWER SUPPLY ROUTING" in EL section and Wiring Diagram.

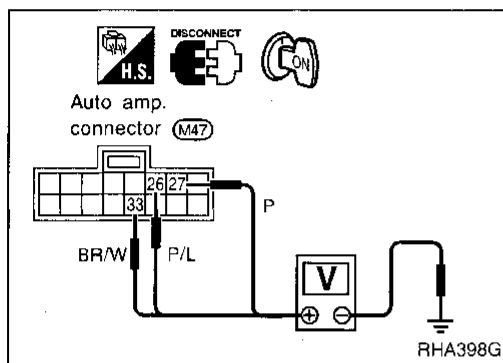

AUTO AMP. (LCU) CHECK

Check power supply circuit for auto amp. (LCU) with ignition switch ON.

1. Disconnect auto amp. (LCU) harness connector.
2. Connect voltmeter from harness side.
3. Measure voltage across terminal ②⑥, ②⑦, ③③ and body ground.

Voltmeter terminal		Voltage
⊕	⊖	
②⑥, ②⑦, ③③	Body ground	Approx. 12V

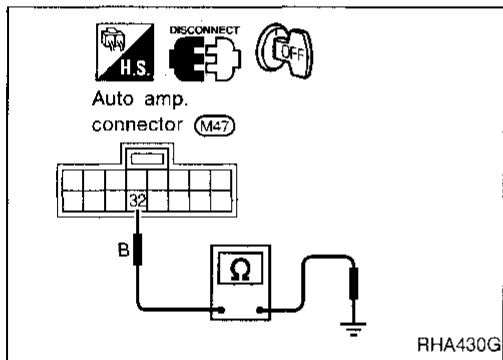

Check body ground circuit for push control unit.

1. Disconnect push control unit harness connector.
2. Connect ohmmeter from harness side.
3. Check for continuity between terminal ③② and body ground.

Ohmmeter terminal		Continuity
⊕	⊖	
③②	Body ground	Yes

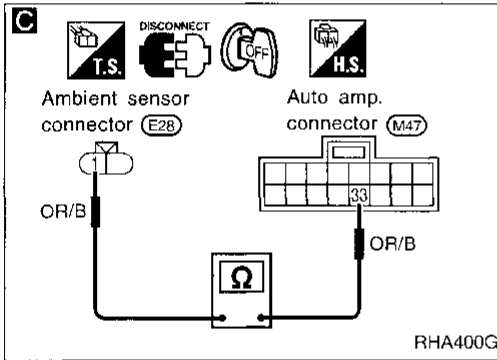
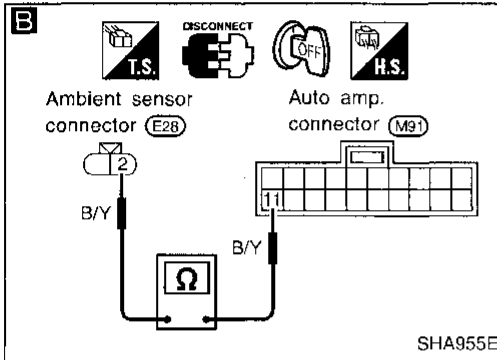
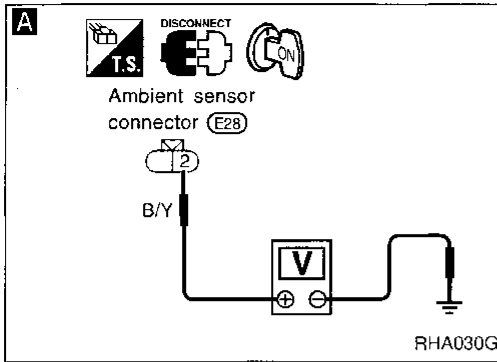

Diagnostic Procedure 1

SYMPTOM: Ambient sensor circuit is open or shorted. (21 or -21 is indicated on display as a result of conducting Self-diagnosis STEP 2.)

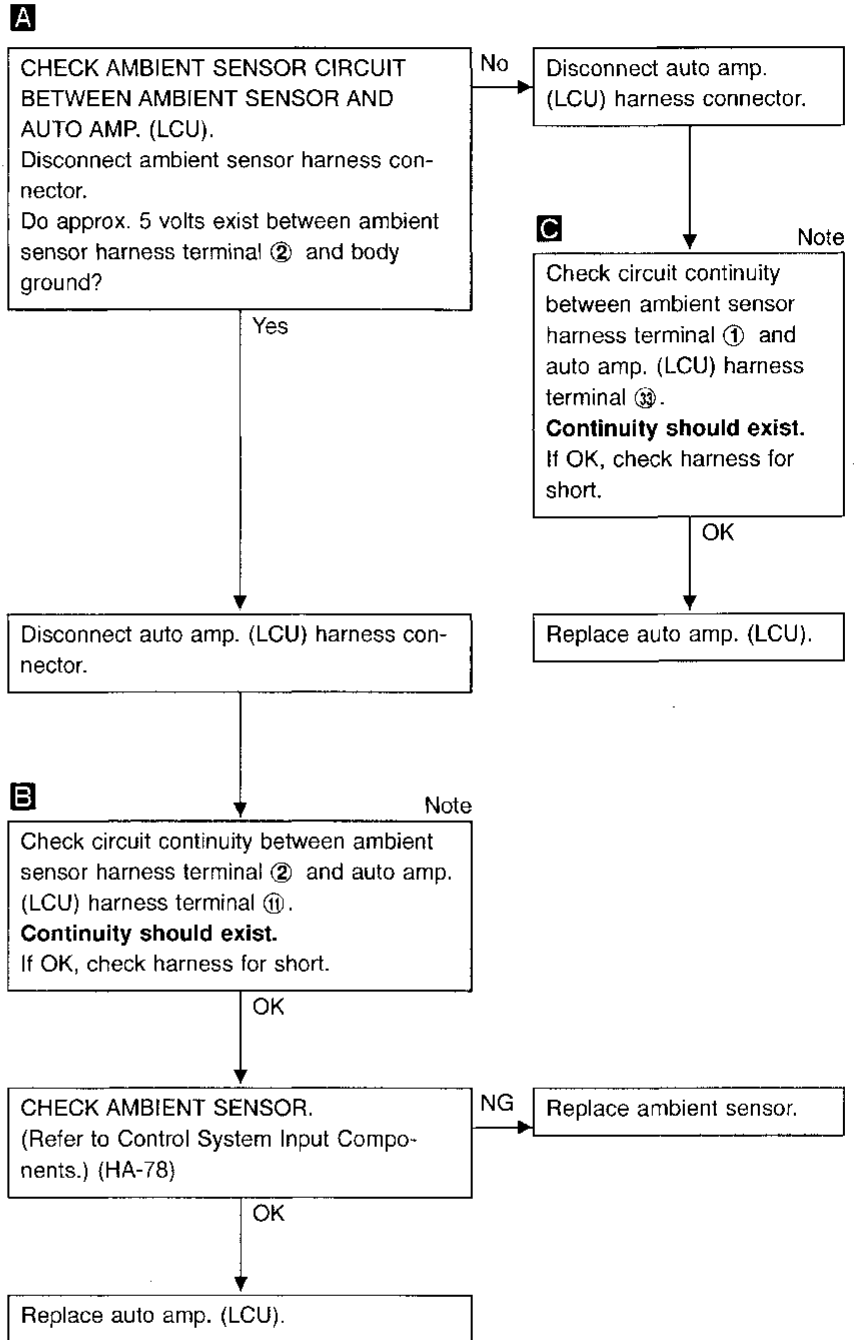

Note:
If the result is NG or No after checking circuit continuity, repair harness or connector.

GI
MA
EM
LC
EC
FE
CL
MT
AT
FA
RA
BR
ST
RS
BT
HA
EL
IDX

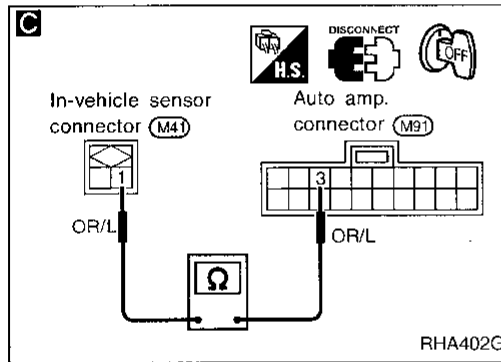
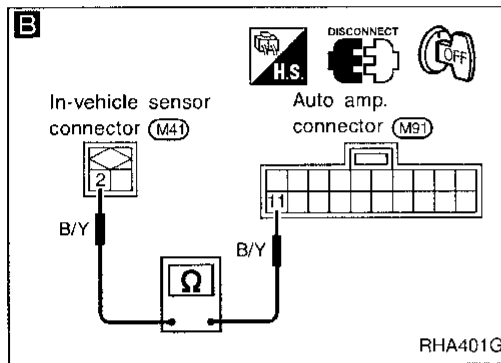
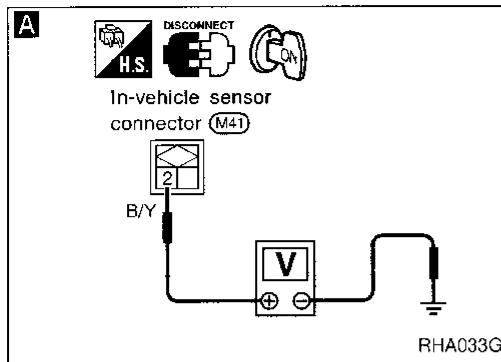

Diagnostic Procedure 2

SYMPTOM: In-vehicle sensor circuit is open or shorted. (?? or -?? is indicated on display as a result of conducting Self-diagnosis STEP 2.)

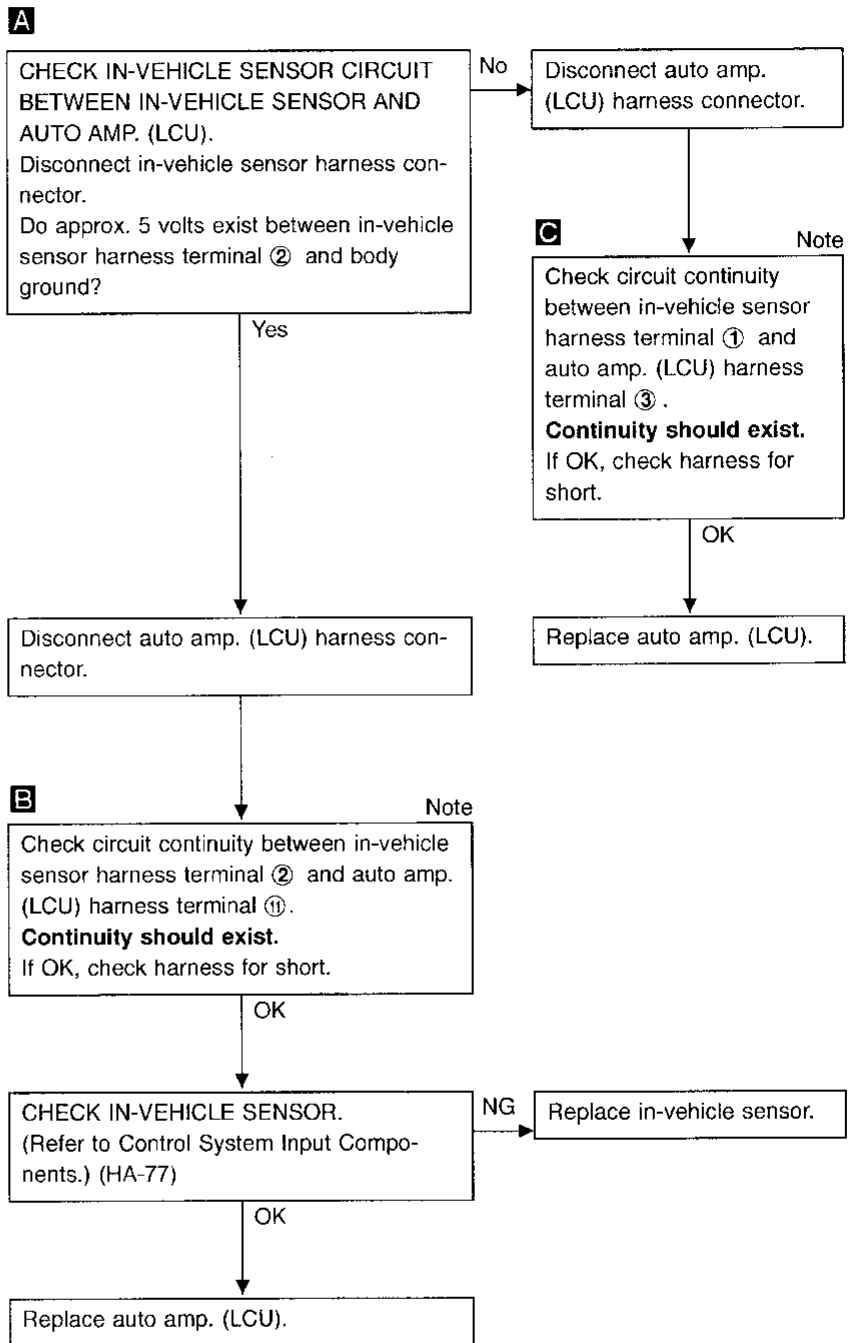

Note:

If the result is NG or No after checking circuit continuity, repair harness or connector.

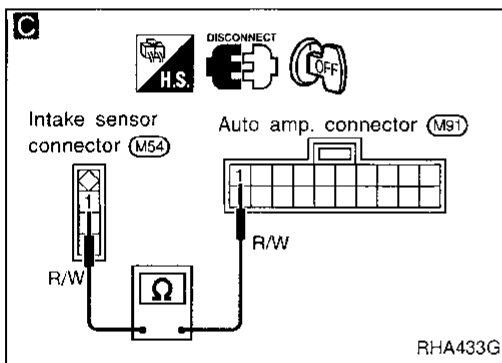
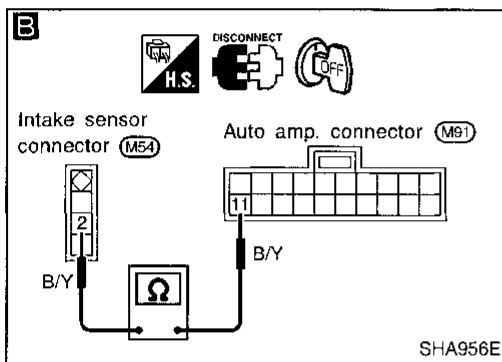
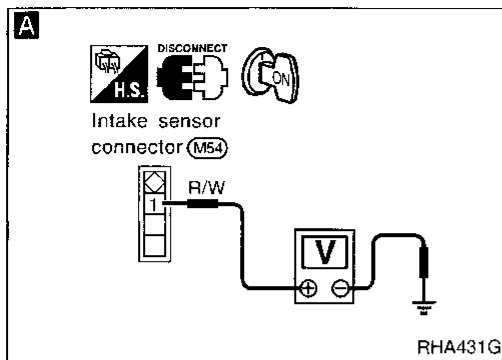

Diagnostic Procedure 3

SYMPTOM: Intake sensor circuit is open or shorted. (24 or -24 is indicated on auto amp. as a result of conducting Self-diagnosis STEP 2.)

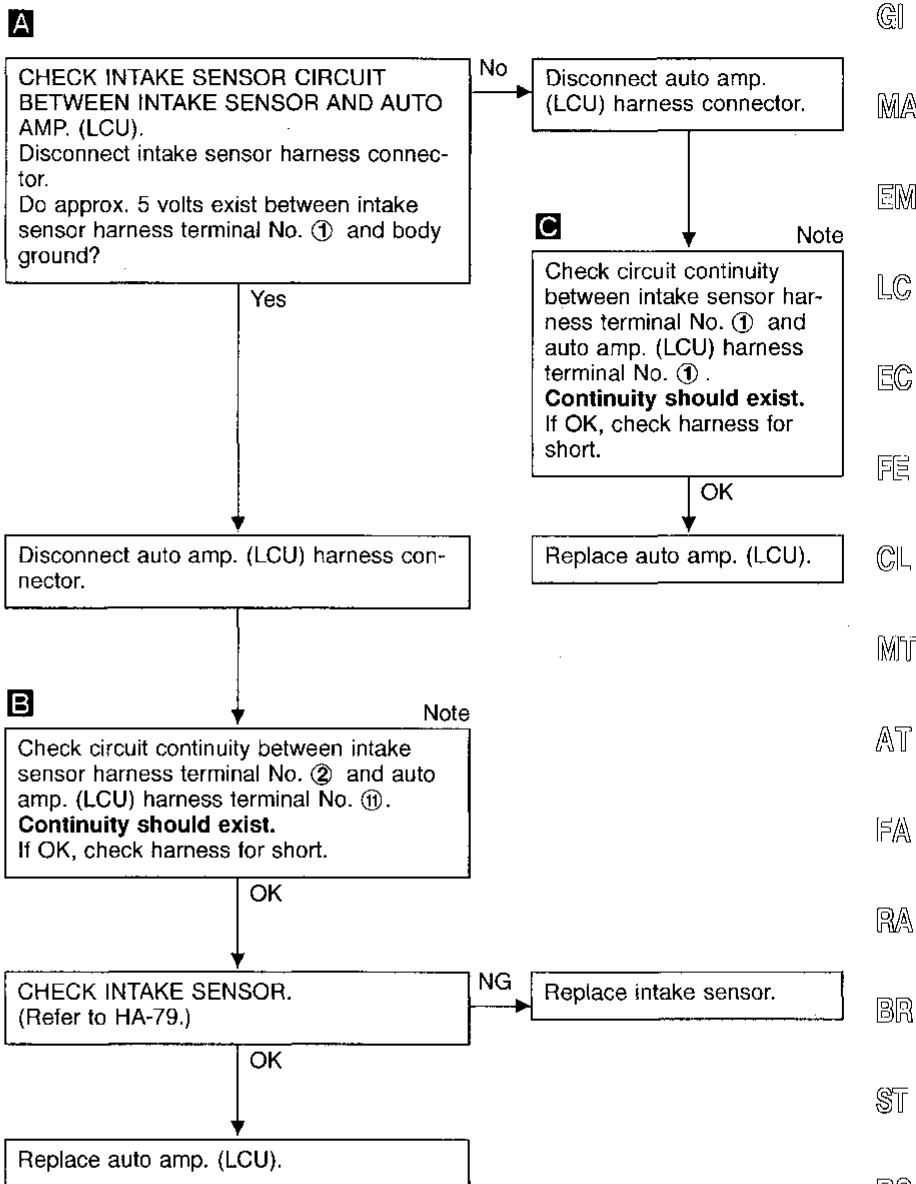

Note:

If the result is NG or No after checking circuit continuity, repair harness or connector.

GI
MA
EM
LC
EC
FE
CL
MT
AT
FA
RA
BR
ST
RS
BT
HA
FL
IDX

TROUBLE DIAGNOSES

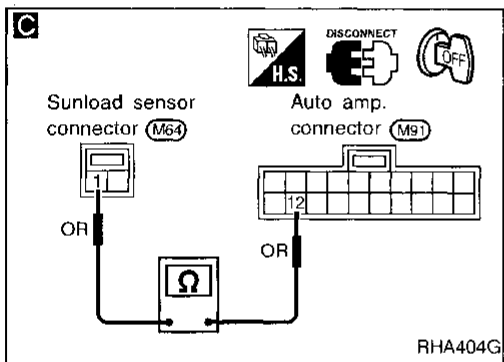
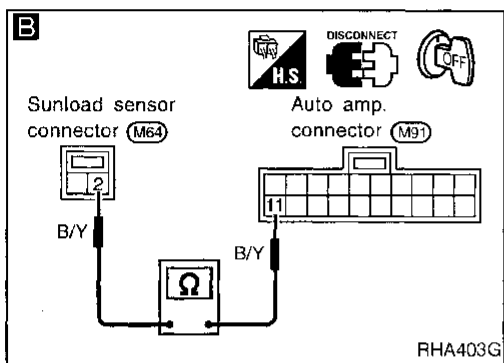
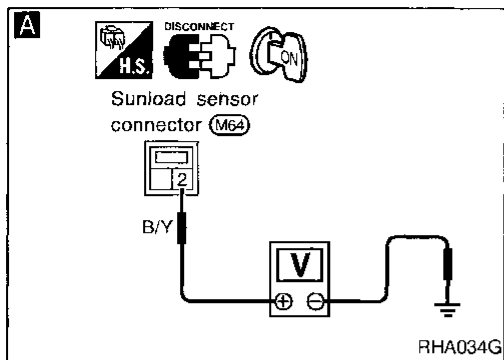

Diagnostic Procedure 4

SYMPTOM: Sunload sensor circuit is open or shorted. (25 or -25 is indicated on display as a result of conducting Self-diagnosis STEP 2.)

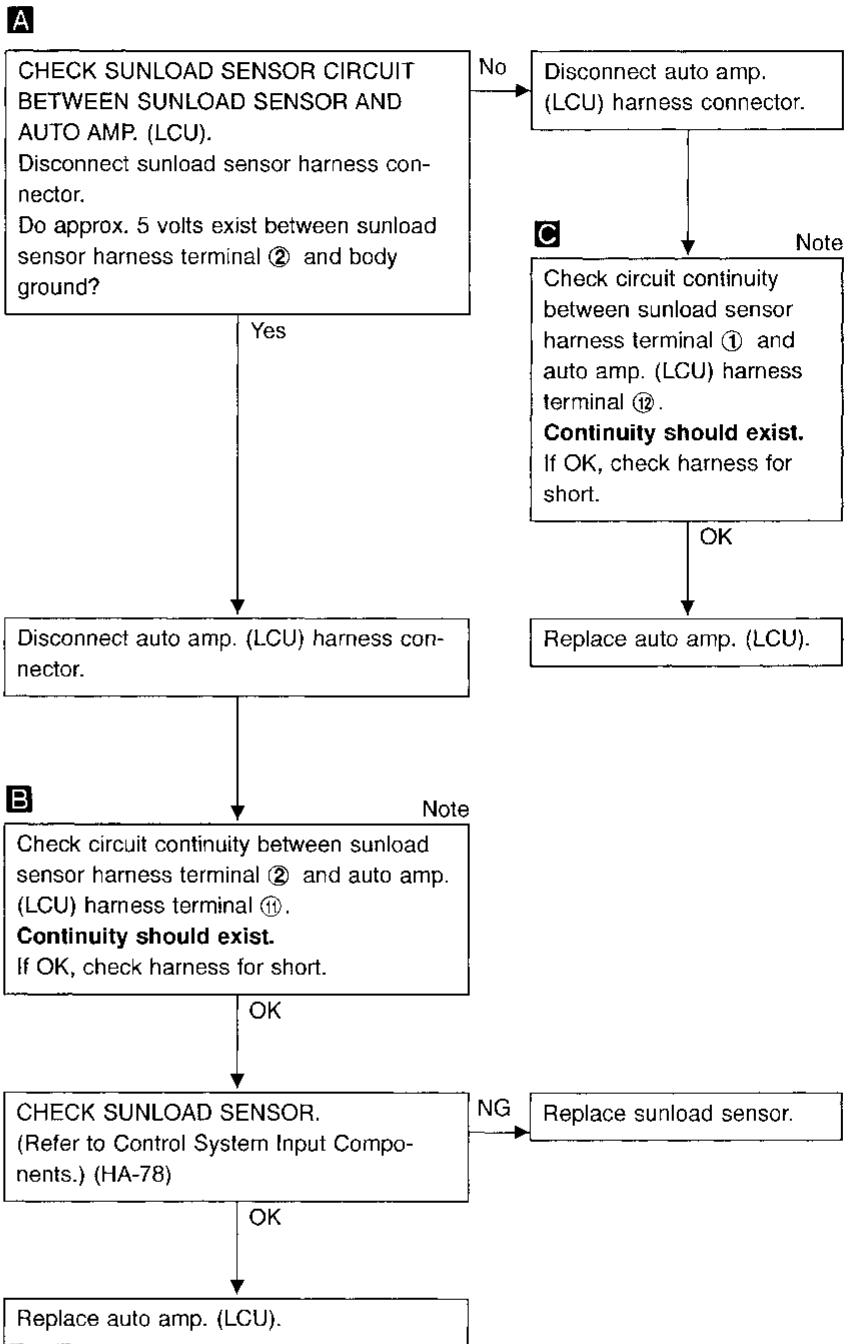

Note:

If the result is NG or No after checking circuit continuity, repair harness or connector.

TROUBLE DIAGNOSES

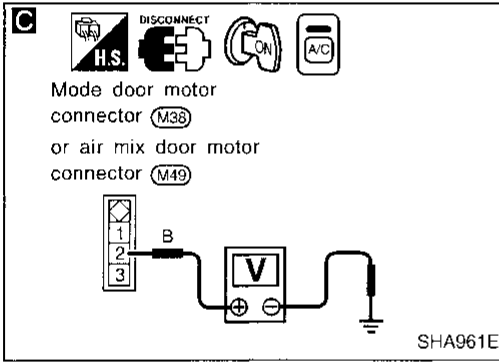
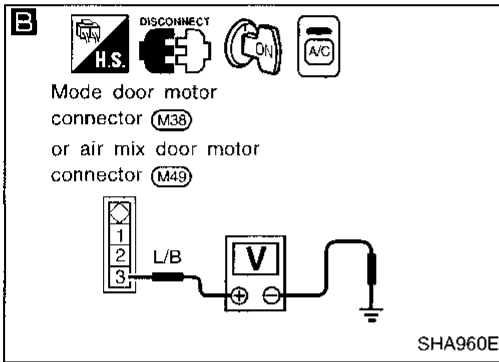
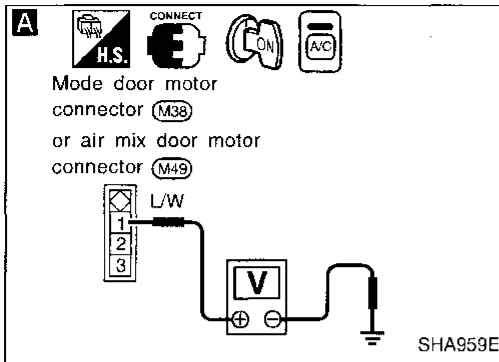

Diagnostic Procedure 5

SYMPTOM: Either mode door motor or air mix door motor does not operate normally.

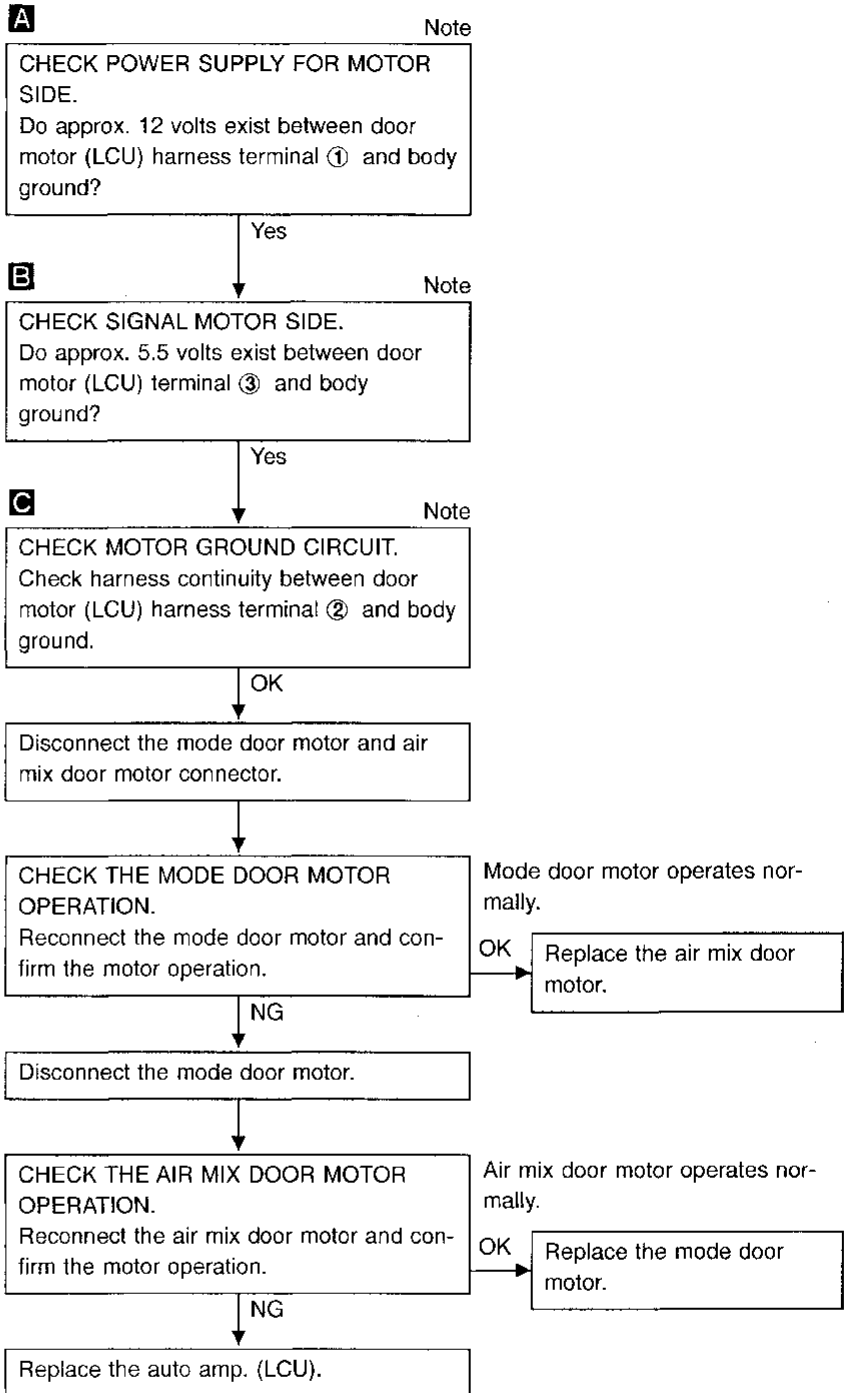

Note:

If the result is NG or No after checking circuit continuity, repair harness or connector.

GI

MA

EM

LC

EC

FE

CL

MT

AT

FA

RA

BR

ST

RS

BT

HA

EL

IDX

Diagnostic Procedure 6

SYMPTOM: Mode door motor and air mix door motor do not operate normally.

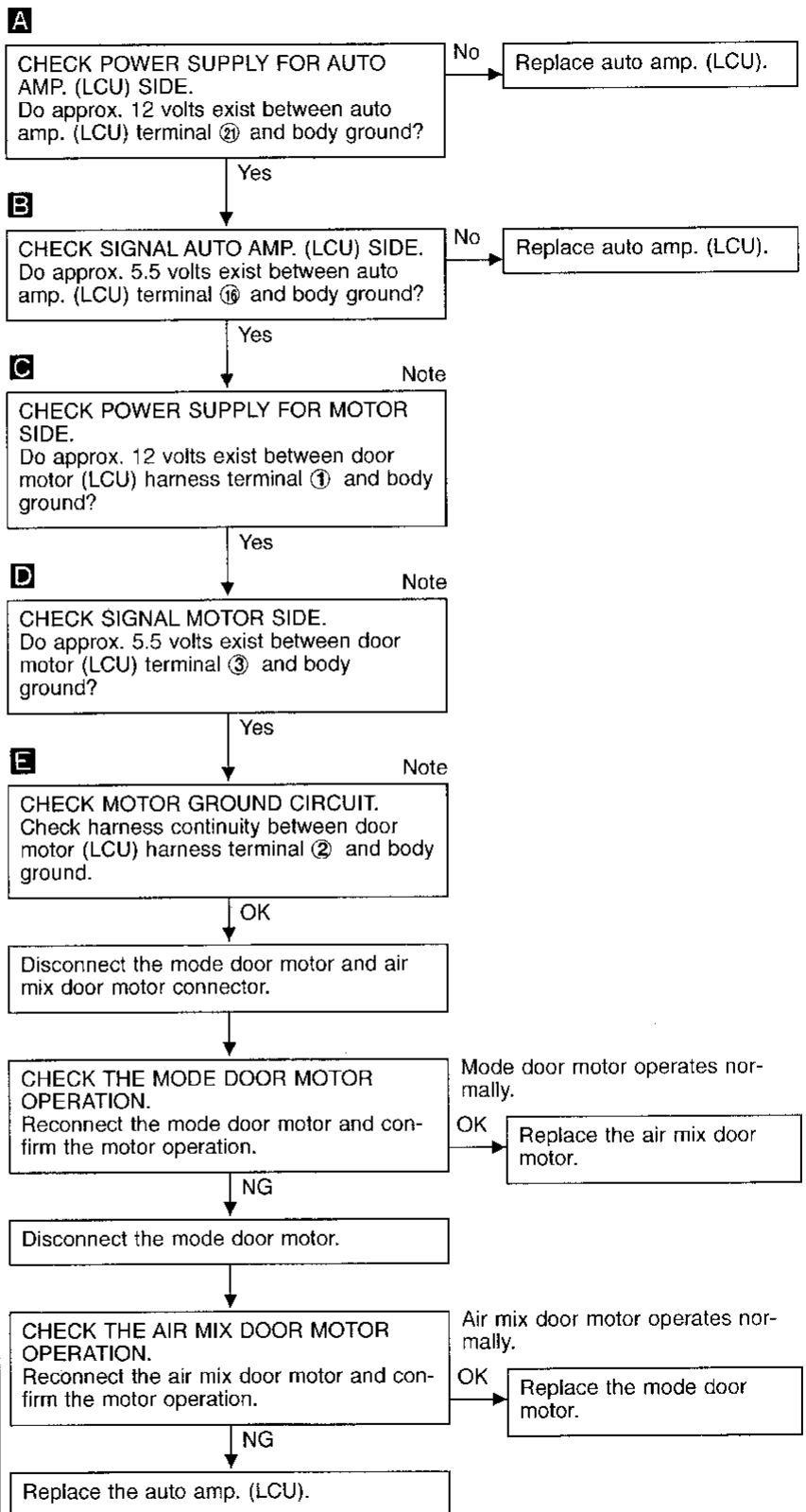
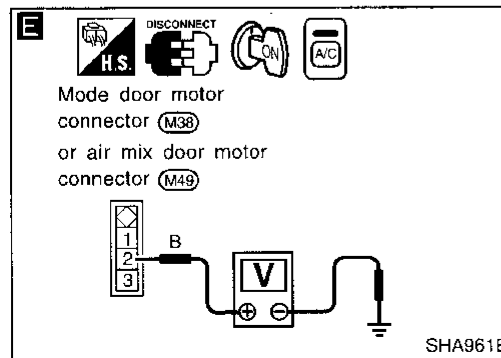
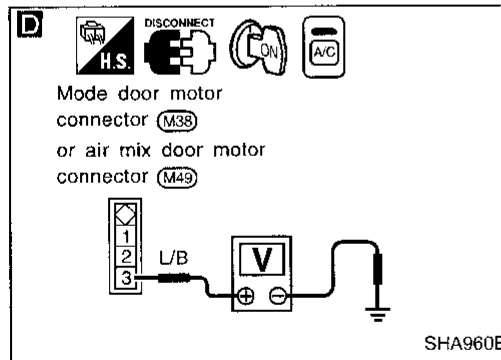
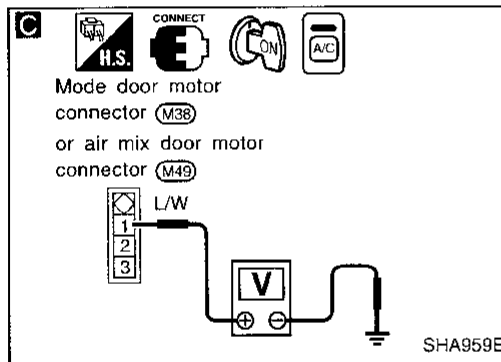
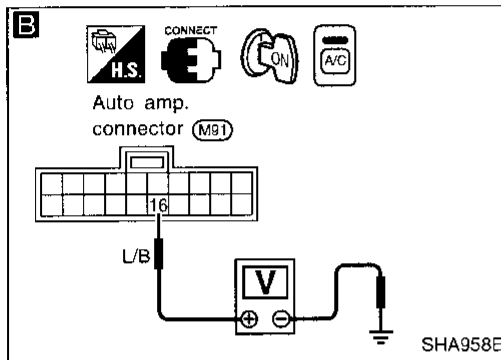
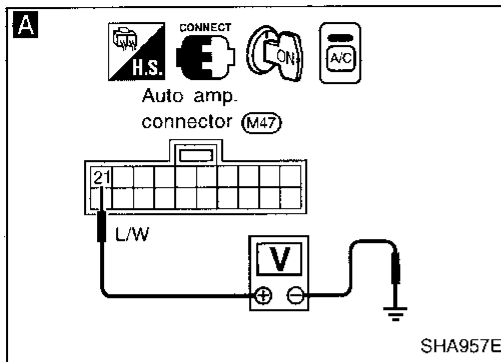

Note:

If the result is NG or No after checking circuit continuity, repair harness or connector.

TROUBLE DIAGNOSES

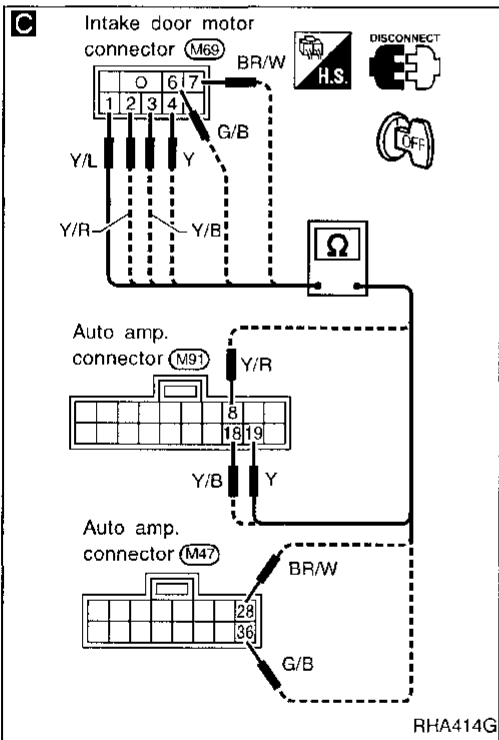
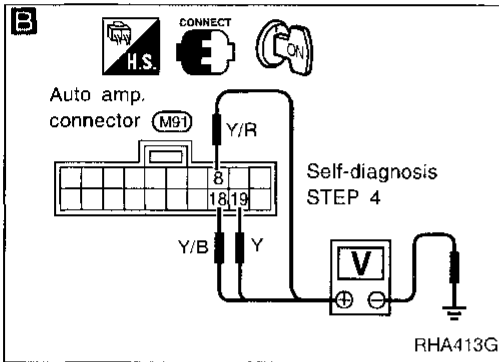
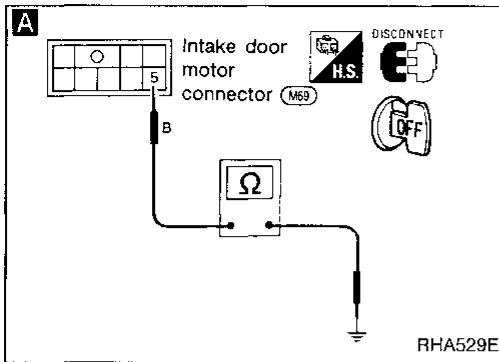

Diagnostic Procedure 7

SYMPTOM: Intake door motor does not operate normally.

- Perform Self-diagnosis STEPS 1, 2 and 4 before referring to the flow chart.

A Note

CHECK BODY GROUND CIRCUIT FOR INTAKE DOOR MOTOR.
Disconnect intake door motor harness connector.
Does continuity exist between intake door motor harness terminal ⑤ and body ground?

Yes

Reconnect intake door motor harness connector.

B Note

CHECK FOR AUTO AMP. (LCU) OUTPUT.
Set up Self-diagnosis STEP 4.
Measure voltage across auto amp. (LCU) harness terminals and body ground.

Code No.	Terminal No.		Condition	Voltage V
	⊕	⊖		
41 42	⑩	Body ground	REC	12
	⑧, ⑬			0
43	⑧	Body ground	20% REC	12
	⑩, ⑬			0
44 45 46	⑩	Body ground	FRE	12
	⑩, ⑧			0

12V: Approx. 12V
If OK, check harness for short.

OK

INSPECTION END

Note:
If the result is NG or No after checking circuit continuity, repair harness or connector.

C Note

Check circuit continuity between each terminal on auto amp. (LCU) and on intake door motor.

Terminal No.		Continuity
Auto amp. (LCU)	Intake door motor	
⑧	①	Yes
⑩	②	
⑩	③	
⑧	④	
⑩	⑦	
⑩	⑥	

If OK, check harness for short.

OK

Ⓐ
(Go to next page.)

GI

MA

EM

LC

EC

FE

CL

MT

AT

FA

RA

BR

ST

RS

BT

HA

EL

IDX

TROUBLE DIAGNOSES

Diagnostic Procedure 7 (Cont'd)

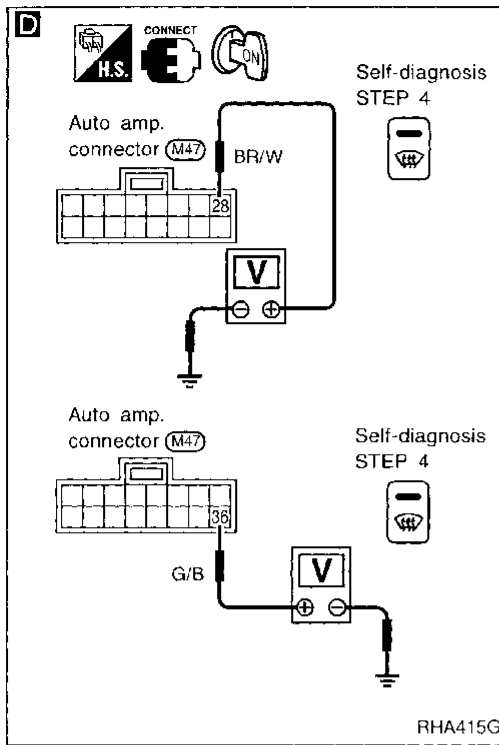

D

CHECK FOR AUTO AMP. (LCU) OUTPUT. NG → Replace auto amp. (LCU).
 Set up Self-diagnosis STEP 4.
 Measure voltage across auto amp. (LCU) harness terminals and body ground.

Code No.	Terminal No.		Condition	Voltage V
	⊕	⊖		
41	28	Body ground	REC	12
42	38			0
44	28	Body ground	FRE	0
45	38			12
46				

0V: Approx. 0V
 12V: Approx. 12V

OK → Replace intake door motor.

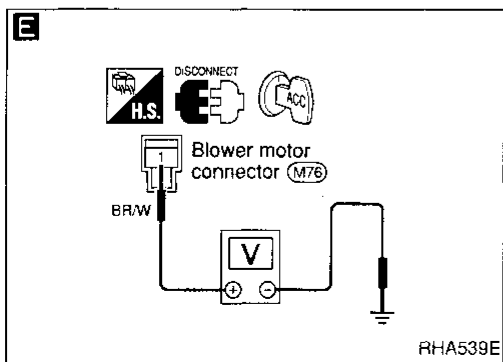
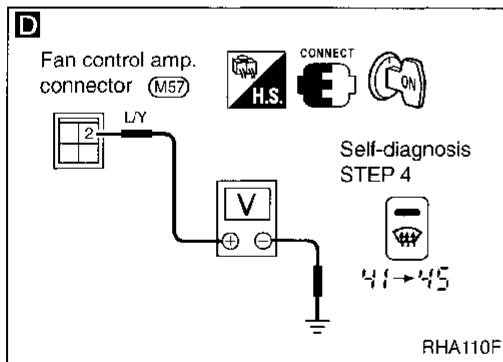
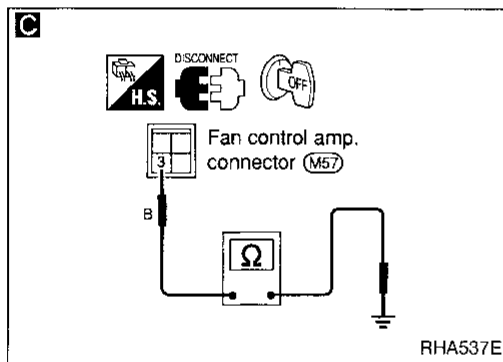
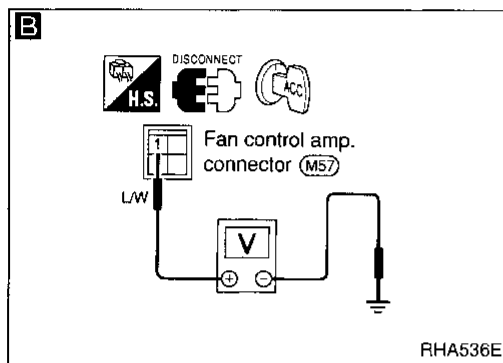
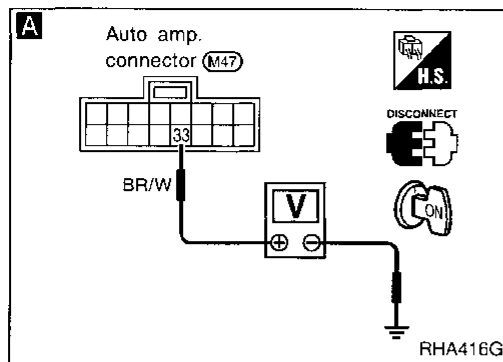

Diagnostic Procedure 8

SYMPTOM: Blower motor operation is malfunctioning under out of Starting Fan Speed Control.

- Perform Preliminary Check 5 before referring to the following flow chart.

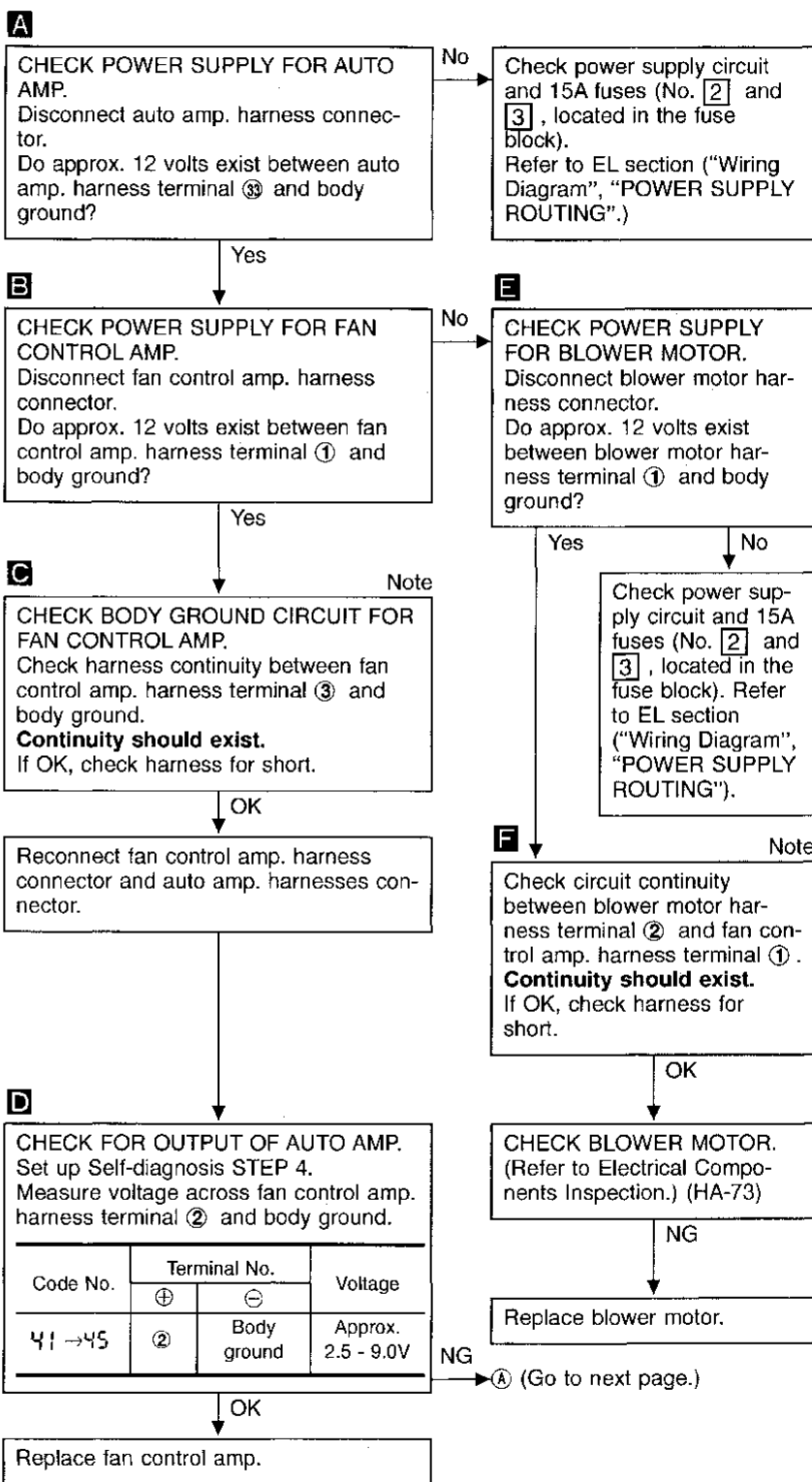

Note:

If the result is NG or No after checking circuit continuity, repair harness or connector.

TROUBLE DIAGNOSES

Diagnostic Procedure 8 (Cont'd)

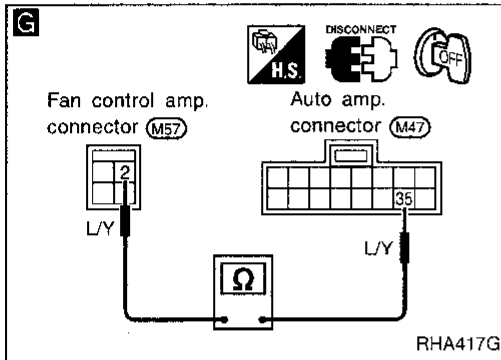
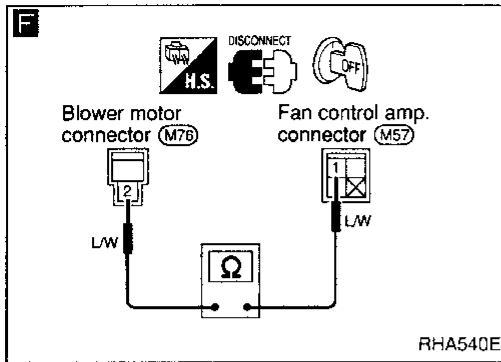

A

Disconnect auto amp. (LCU) and fan control amp. harness connector.

G

Note

Check harness continuity between auto amp. (LCU) harness terminal ③⑤ and fan control amp. harness terminal ②.

Continuity should exist.

If OK, check harness for short.

OK

Replace auto amp. (LCU).

Note:

If the result is NG or No after checking circuit continuity, repair harness or connector.

TROUBLE DIAGNOSES

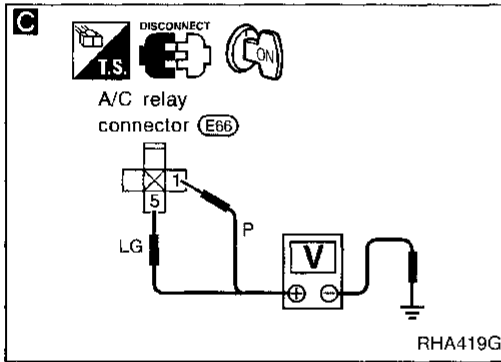
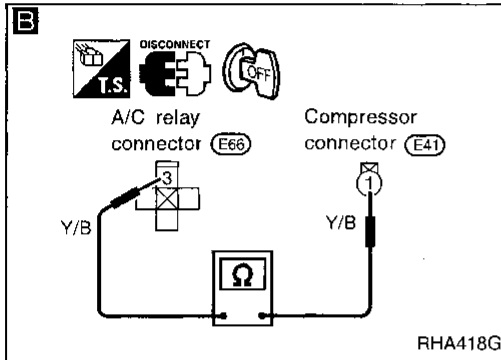
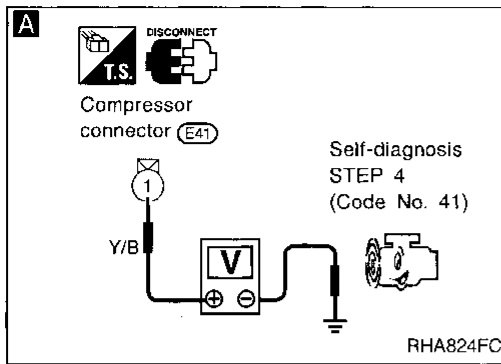

Diagnostic Procedure 9

SYMPTOM: Magnet clutch does not engage after performing Preliminary Check 6.

- Perform Preliminary Check 6 before referring to the flow chart.

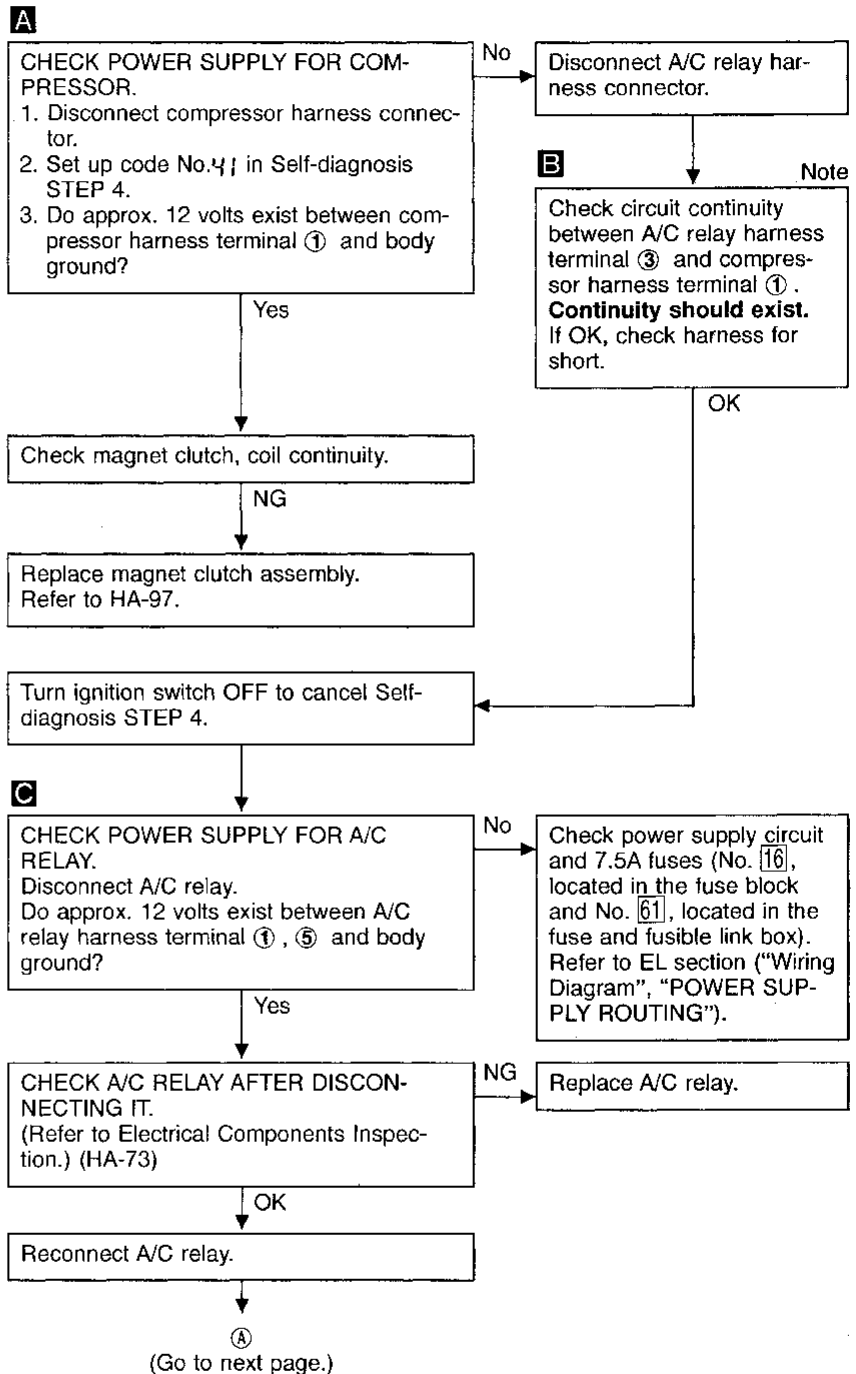

Note:

If the result is NG or No after checking circuit continuity, repair harness or connector.

TROUBLE DIAGNOSES

Diagnostic Procedure 9 (Cont'd)

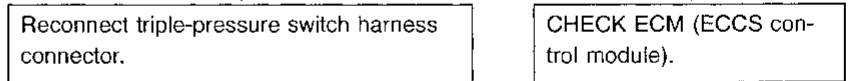
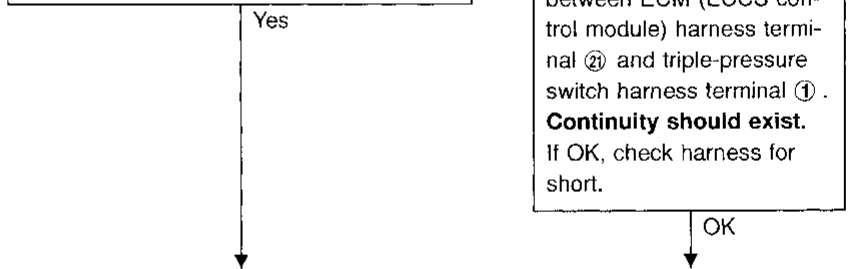
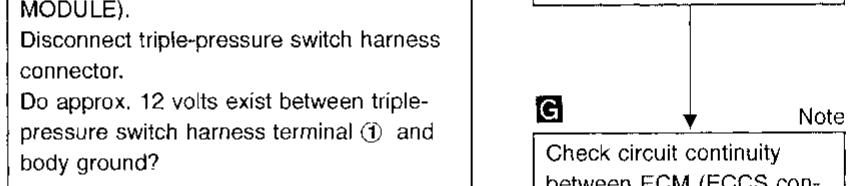
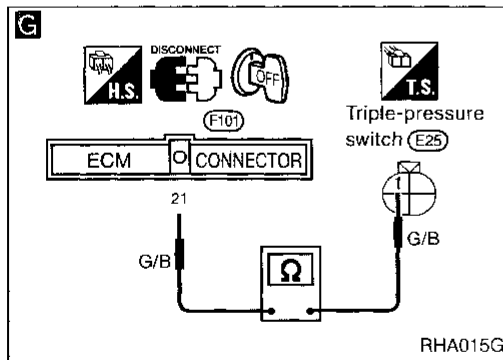
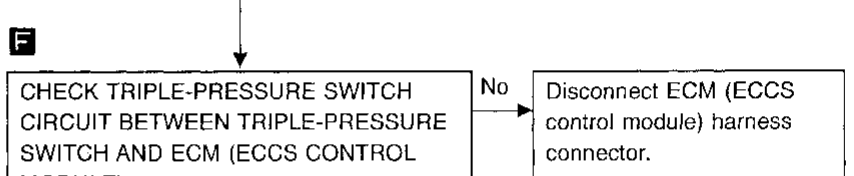
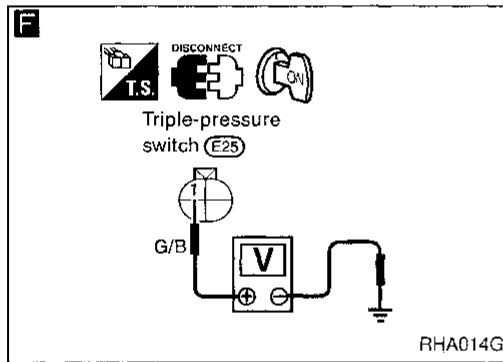
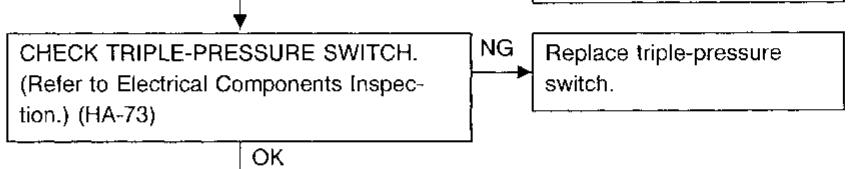
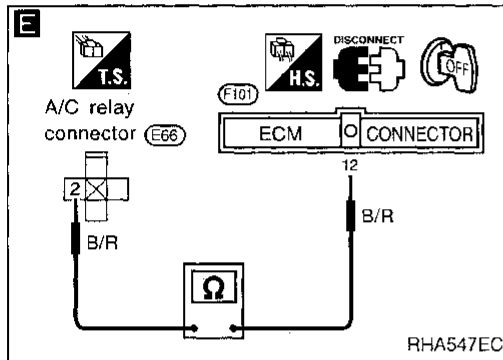
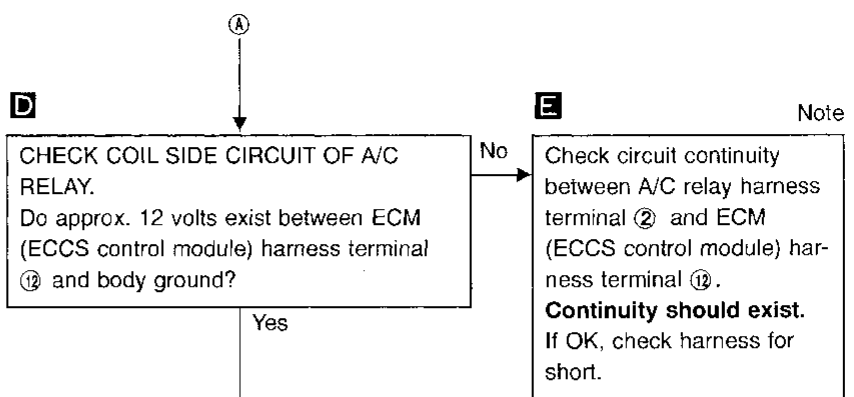
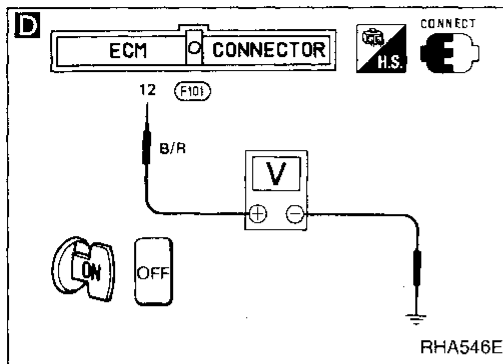

Note:

If the result is NG or No after checking circuit continuity, repair harness or connector.

TROUBLE DIAGNOSES

Diagnostic Procedure 9 (Cont'd)

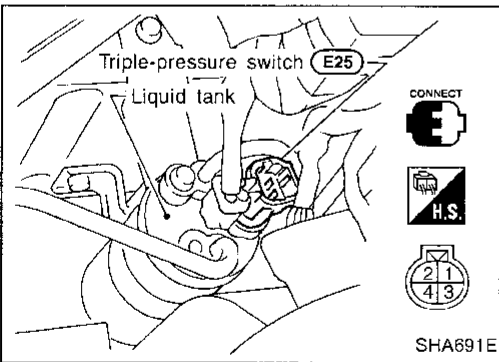
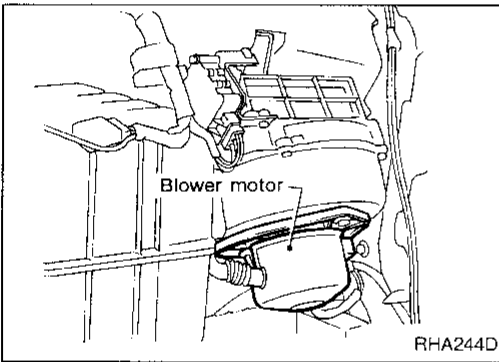
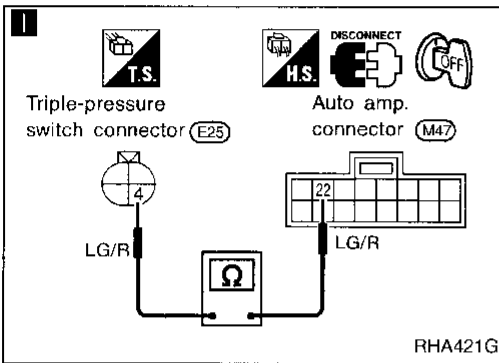
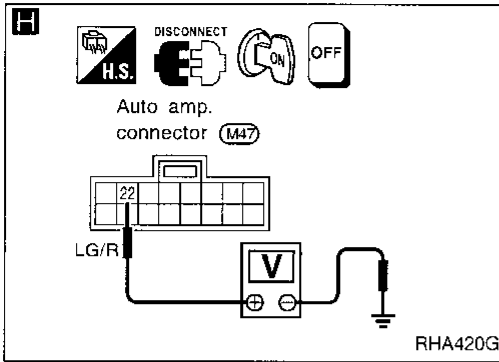

⑤
Disconnect auto amp. (LCU) harness connector.

⑥
CHECK AUTO AMP. (LCU) CIRCUIT BETWEEN AUTO AMP. (LCU) AND TRIPLE-PRESSURE SWITCH.
Do approx. 12 volts exist between auto amp. (LCU) harness terminal ② and body ground?

Note
Check circuit continuity between auto amp. (LCU) harness terminal ② and triple-pressure switch harness terminal ④.
Continuity should exist.
If OK, check harness for short.

Yes
Replace auto amp. (LCU).

Note:
If the result is NG or No after checking circuit continuity, repair harness or connector.

Electrical Components Inspection BLOWER MOTOR

Check blower motor for smooth rotation.

- Ensure that there are no foreign particles inside the intake unit.

TRIPLE-PRESSURE SWITCH

	Terminals	High-pressure side line pressure kPa (kg/cm ² , psi)	Operation	Continuity
Low-pressure side	① - ④	Increasing to 157 - 226 (1.6 - 2.3, 23 - 33)	ON	Exists.
		Decreasing to 152.0 - 201.0 (1.55 - 2.05, 22.0 - 29.2)	OFF	Does not exist.
Medium-pressure side*	② - ③	Increasing to 1,422 - 1,618 (14.5 - 16.5, 206 - 235)	ON	Exists.
		Decreasing to 1,128 - 1,422 (11.5 - 14.5, 164 - 206)	OFF	Does not exist.
High-pressure side	① - ④	Decreasing to 1,667 - 2,059 (17 - 21, 242 - 299)	ON	Exists.
		Increasing to 2,452 - 2,844 (25 - 29, 356 - 412)	OFF	Does not exist.

* For cooling fan motor operation.

TROUBLE DIAGNOSES

Electrical Components Inspection (Cont'd)

A/C RELAY

Check circuit continuity between terminals by supplying 12 volts to coil side terminals of the relay.

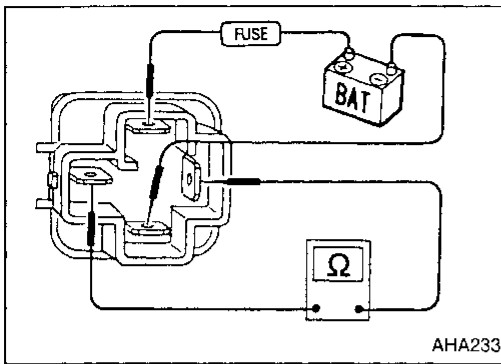

AHA233

Control Linkage Adjustment

MODE DOOR

1. Install mode door motor on heater unit and connect it to main harness.
Make sure lever of mode door motor is fitted into the slit of mode door link.
2. Set up code No. 45 in Self-diagnosis STEP 4.
3. Make sure mode door operates properly when changing from code No. 41 to 45 by pushing DEF switch.

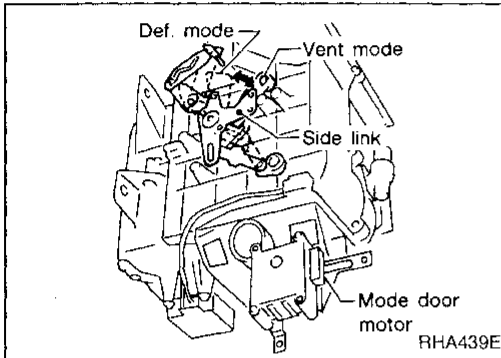

RHA439E

41	42	43	44	45	46
VENT	B/L	B/L	FOOT	F/D	DEF

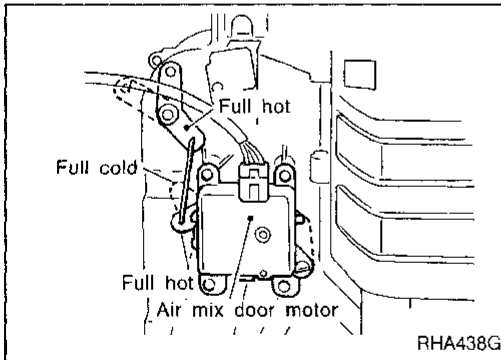

RHA438G

AIR MIX DOOR

1. Install air mix door motor on heater unit and connect it to main harness.
Make sure lever of Air mix door is fitted into the slit of air mix door link.
2. Set up code No. 41 in Self-diagnosis STEP 4.
3. Make sure air mix door operates properly when changing from code No. 41 to 45 by pushing DEF switch.

41	42	43	44	45	46
Full cold			Full hot		

TROUBLE DIAGNOSES

Control Linkage Adjustment (Cont'd)

INTAKE DOOR

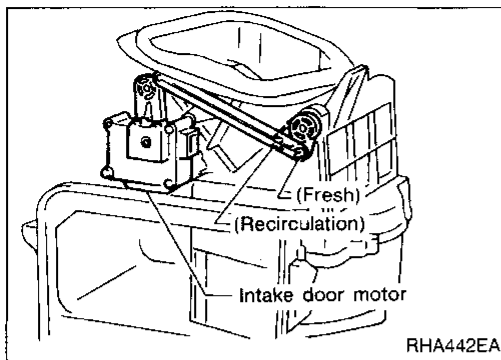

1. Install intake door motor on intake unit and connect it to main harness.
Make sure lever of intake door motor is fitted in the slit of intake door link.
2. Set up code No. 41 in Self-diagnosis STEP 4.
3. Make sure intake door operates properly when changing from code No. 41 to 45 by pushing DEF switch.

41	42	43	44	45	46
REC		20% FRE	FRE		

GI

MA

EM

LC

EC

FE

CL

MT

AT

FA

RA

BR

ST

RS

BT

HA

EL

IDX

SYSTEM DESCRIPTION

Overview of Control System

The control system consists of a) input sensors and switches, b) the auto amp. (microcomputer), and c) outputs. The relationship of these components is shown in the diagram below:

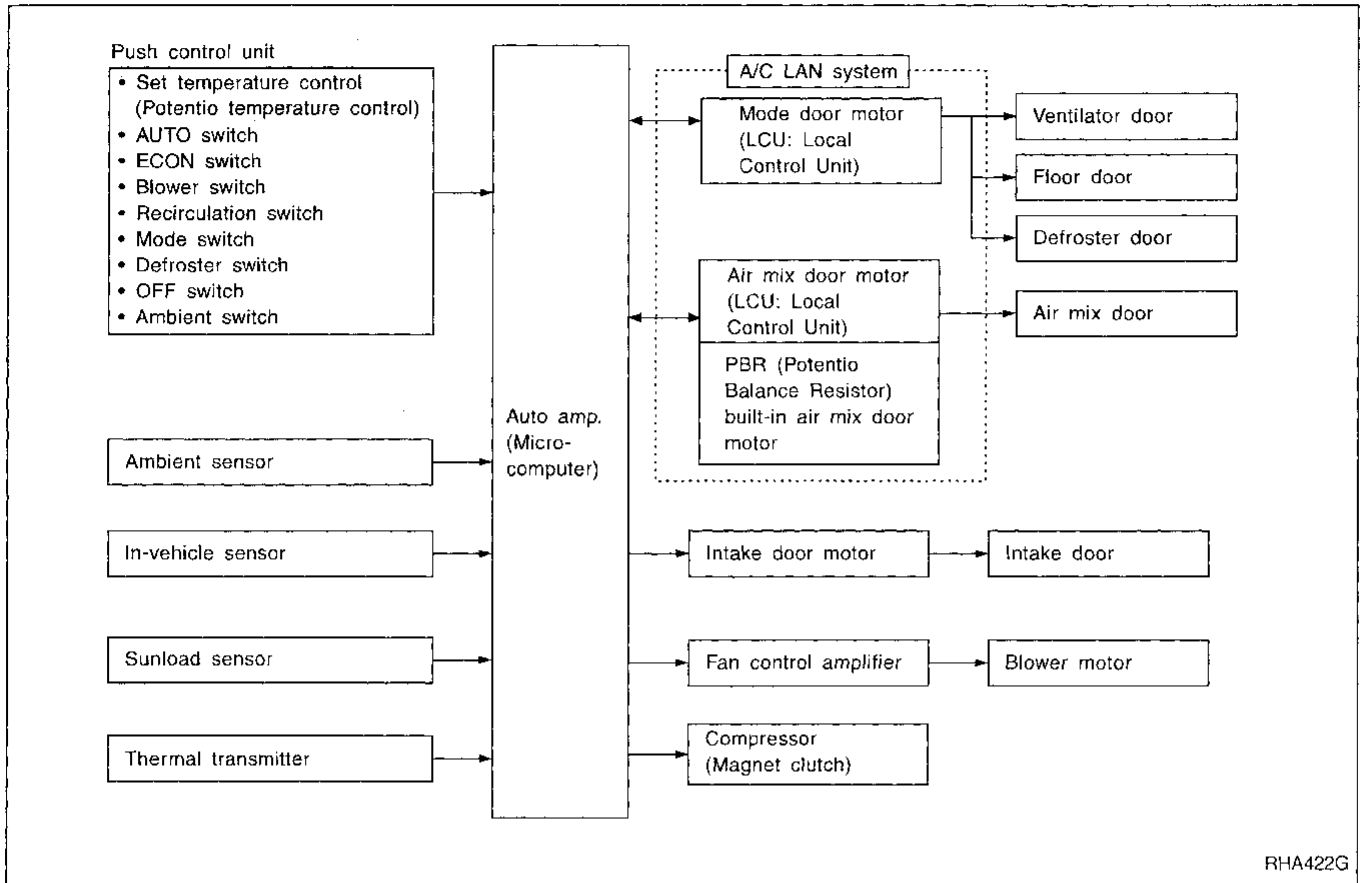

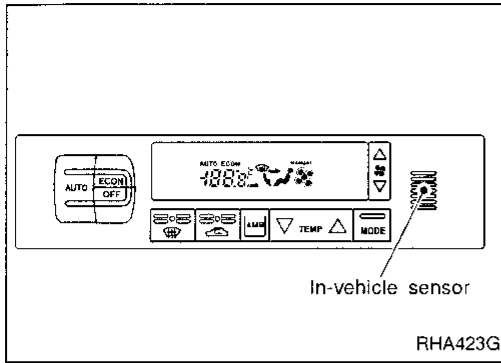

Control System Input Components

POTENTIO TEMPERATURE CONTROL (PTC)

The PTC is built into the push control unit. It can be set at an interval of 1°C (2°F) through both ▲ (HOT) and ▼ (COLD) control switches. Setting temperature is digitally displayed.

IN-VEHICLE SENSOR

The in-vehicle sensor is attached to A/C control finisher. It converts variations in temperature of compartment air drawn from an aspirator into a resistance value. It is then input into the auto amp. After disconnecting in-vehicle sensor harness connector, measure resistance between terminals ① and ② at sensor harness side, using the table below.

Temperature °C (°F)	Resistance kΩ
-15 (5)	12.73
-10 (14)	9.92
-5 (23)	7.80
0 (32)	6.19
5 (41)	4.95
10 (50)	3.99
15 (59)	3.24
20 (68)	2.65
25 (77)	2.19
30 (86)	1.81
35 (95)	1.51
40 (104)	1.27
45 (113)	1.07

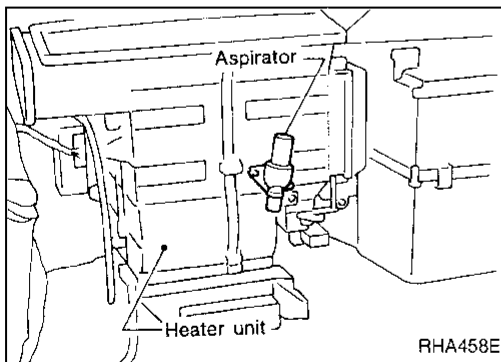

ASPIRATOR

The aspirator is located on heater unit. It produces vacuum pressure due to air discharged from the heater unit, continuously taking compartment air in the aspirator.

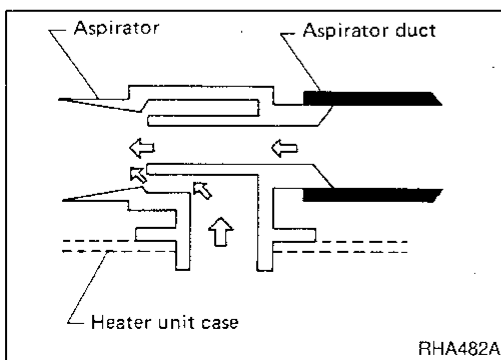

SYSTEM DESCRIPTION

Control System Input Components (Cont'd)

AMBIENT SENSOR

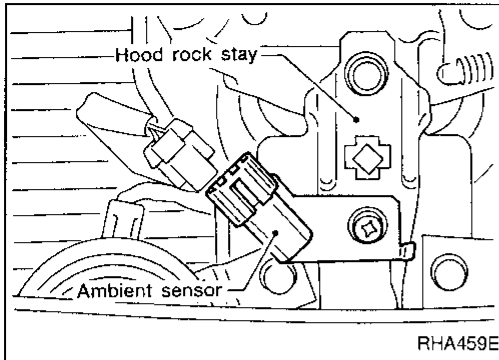

The ambient sensor is attached to the radiator core support. It detects ambient temperature and converts it into a resistance value which is then input to the auto amp.

After disconnecting ambient sensor harness connector, measure resistance between terminals ① and ② at sensor harness side, using the table below.

Temperature °C (°F)	Resistance kΩ
-15 (5)	12.73
-10 (14)	9.92
-5 (23)	7.80
0 (32)	6.19
5 (41)	4.95
10 (50)	3.99
15 (59)	3.24
20 (68)	2.65
25 (77)	2.19
30 (86)	1.81
35 (95)	1.51
40 (104)	1.27
45 (113)	1.07

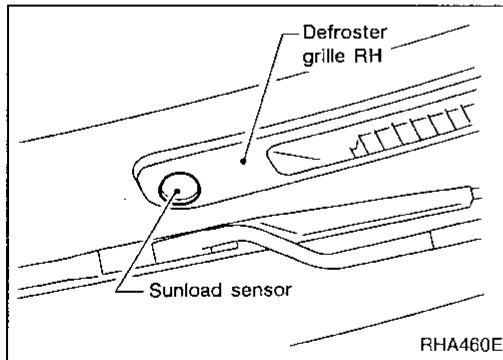

SUNLOAD SENSOR

The sunload sensor is located on the right defroster grille. It detects sunload entering through windshield by means of a photo diode and converts it into a current value which is then input to the auto amp.

Measure voltage between terminals ① and ② at vehicle harness side, using the table below.

Input current mA	Output voltage V
0	5.0
0.1	4.1
0.2	3.1
0.3	2.2
0.4	1.3
0.5	0.4

- When checking sunload sensor, select a place where sun shines directly on it.

SYSTEM DESCRIPTION

Control System Input Components (Cont'd) INTAKE SENSOR

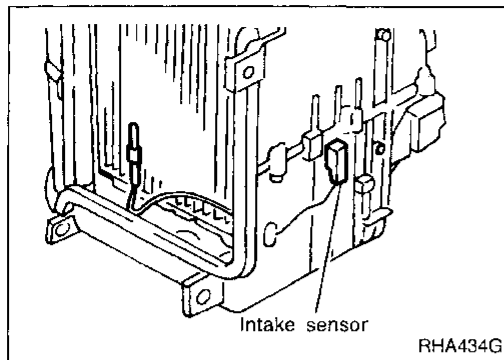

After disconnecting intake sensor harness connector, measure resistance between terminals ① and ⑨ at sensor harness side, using the table below.

Temperature °C (°F)	Resistance kΩ
-20 (-4)	16.2
-10 (14)	9.8
0 (32)	6.0
10 (50)	3.94
20 (68)	2.64
25 (77)	2.12
30 (86)	1.82
40 (104)	1.27

GI
MA
EM
LC
EC
FE
CL
MT
AT
FA
RA
BR
ST
RS
BT
HA
EL
IDX

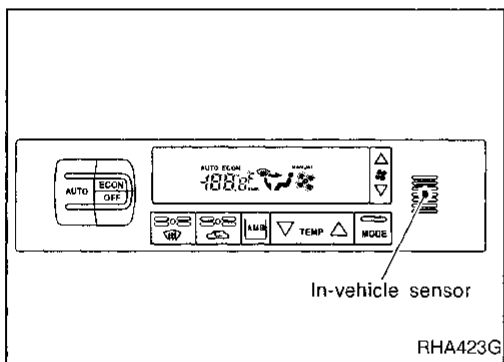

Control System Automatic Amplifier (Auto amp.)

The auto amplifier has a built-in microcomputer which processes information sent from various sensors needed for air conditioning operation. The air mix door motor, mode door motor, intake door motor, blower motor, bi-level door motor and compressor are then controlled.

The auto amp. is unitized with control mechanisms. Signals from various switches and Potentio Temperature Control (PTC) are directly entered into auto amplifier.

Self-diagnostic functions are also built into auto amp. to provide quick check of malfunctions in the auto air conditioning system.

AMBIENT TEMPERATURE INPUT PROCESS

The auto amp. includes a "processing circuit" for the ambient sensor input. When the ambient temperature increases quickly, the processing circuit controls the input from the ambient sensor. It allows the auto amp. to recognize the increase of temperature only 0.2°C (0.4°F) per 100 seconds.

As an example, consider stopping for a cup of coffee after high speed driving. Even though the ambient temperature has not changed, the ambient sensor will detect the increase of temperature. The heat radiated from the engine compartment can radiate to the front grille area. The ambient sensor is located there.

SUNLOAD INPUT PROCESS

The auto amp. also includes a processing circuit which "average" the variations in detected sunload over a period of time. This prevents drastic swings in the ATC system operation due to small or quick variations in detected sunload.

For example, consider driving along a road bordered by an occasional group of large trees. The sunload detected by the sunload sensor will vary whenever the trees obstruct the sunlight. The processing circuit averages the detected sunload over a period of time. As a result, the effect the above mentioned does not cause any change in the ATC system operation. On the other hand, shortly after entering a long tunnel, the system will recognize the change in sunload, and the system will react accordingly.

Control System Output Components

AIR MIX DOOR CONTROL (Automatic temperature control)

Component parts

- Air mix door control system components are:
- 1) Auto amp.
 - 2) Air mix door motor (LCU; Local Control Unit)
 - 3) In-vehicle sensor
 - 4) Ambient sensor
 - 5) Sunload sensor
 - 6) Intake sensor

System operation

The auto amplifier receives data from each of the sensors. The amplifier sends air mix door and mode door opening angle data to the air mix door motor LCU and mode door motor LCU. The air mix door motor and mode door motor read their respective signals according to the address signal. Opening angle indication signals received from the auto amplifier and each of the motor position sensors are compared by the LCUs in each motor with the existing decision and opening angles. Subsequently, HOT/COLD or DEFROST/VENT operation is selected. The new selection data is returned to the auto amplifier.

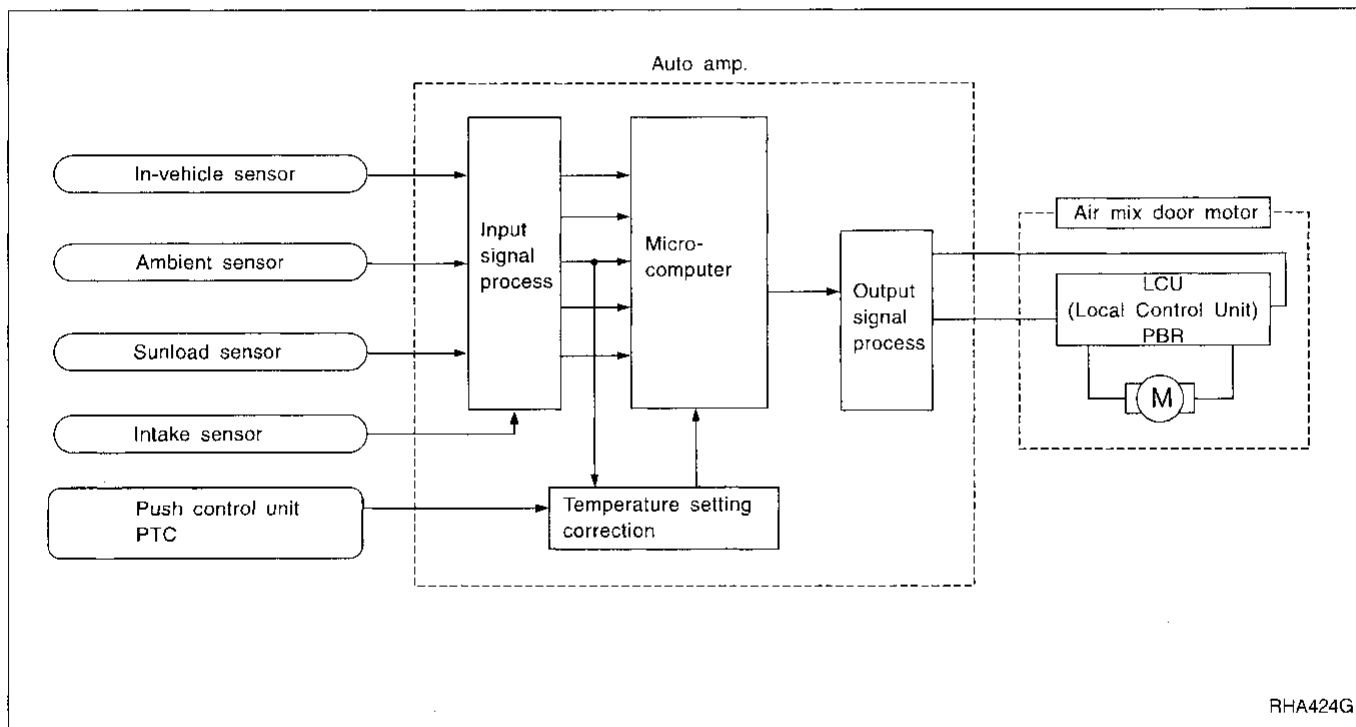

SYSTEM DESCRIPTION

Control System Output Components (Cont'd) Air mix door control specification

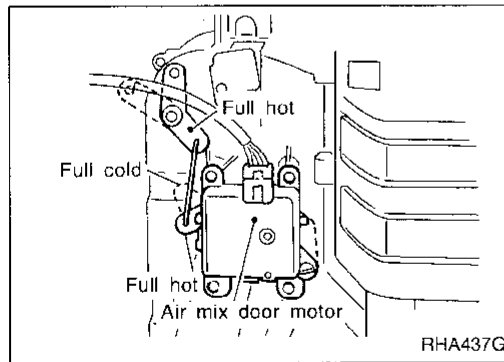
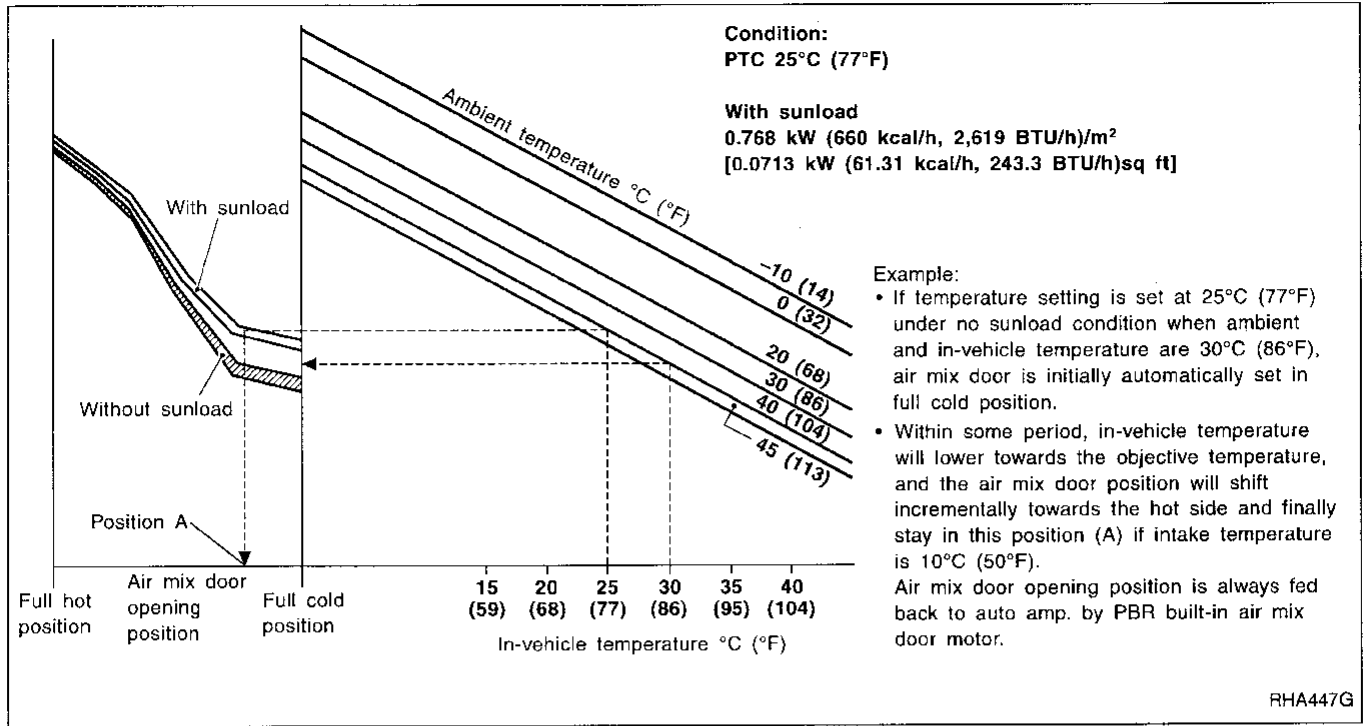

AIR MIX DOOR MOTOR

The air mix door motor is attached to the bottom of the heater unit. It rotates so that the air mix door is opened to a position set by the auto amp. Motor rotation is then conveyed through a shaft and air mix door position is then fed back to the auto amp. by PBR built-in air mix door motor.

GI
MA
EM
LC
EC
FE
CL
MT
AT
FA
RA
BR
ST
RS
BT
HA
EL
IDX

SYSTEM DESCRIPTION

Control System Output Components (Cont'd)

MODE DOOR CONTROL

Component parts

Mode door control system components are:

- 1) Auto amp.
- 2) Mode door motor
- 3) PBR
- 4) In-vehicle sensor
- 5) Ambient sensor
- 6) Sunload sensor
- 7) Intake sensor

System operation

The auto amp. computes the air discharge conditions according to the ambient temperature and the in-vehicle temperature. The computed discharge conditions are then corrected for sunload. By this correction, it is determined through which outlets air will flow into the passenger compartment.

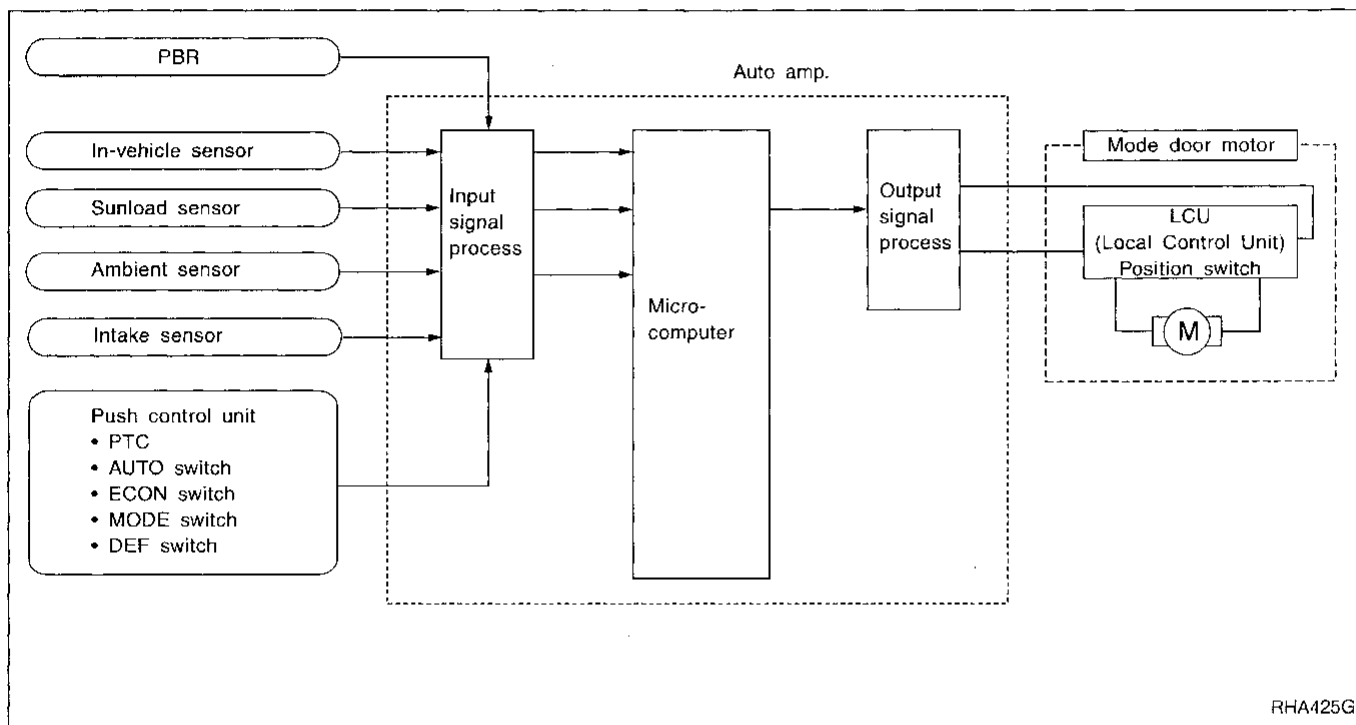

SYSTEM DESCRIPTION

Control System Output Components (Cont'd) Mode door control specification

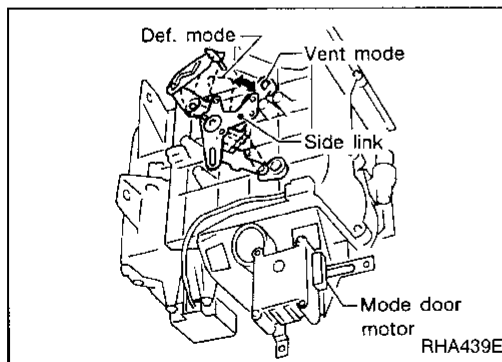
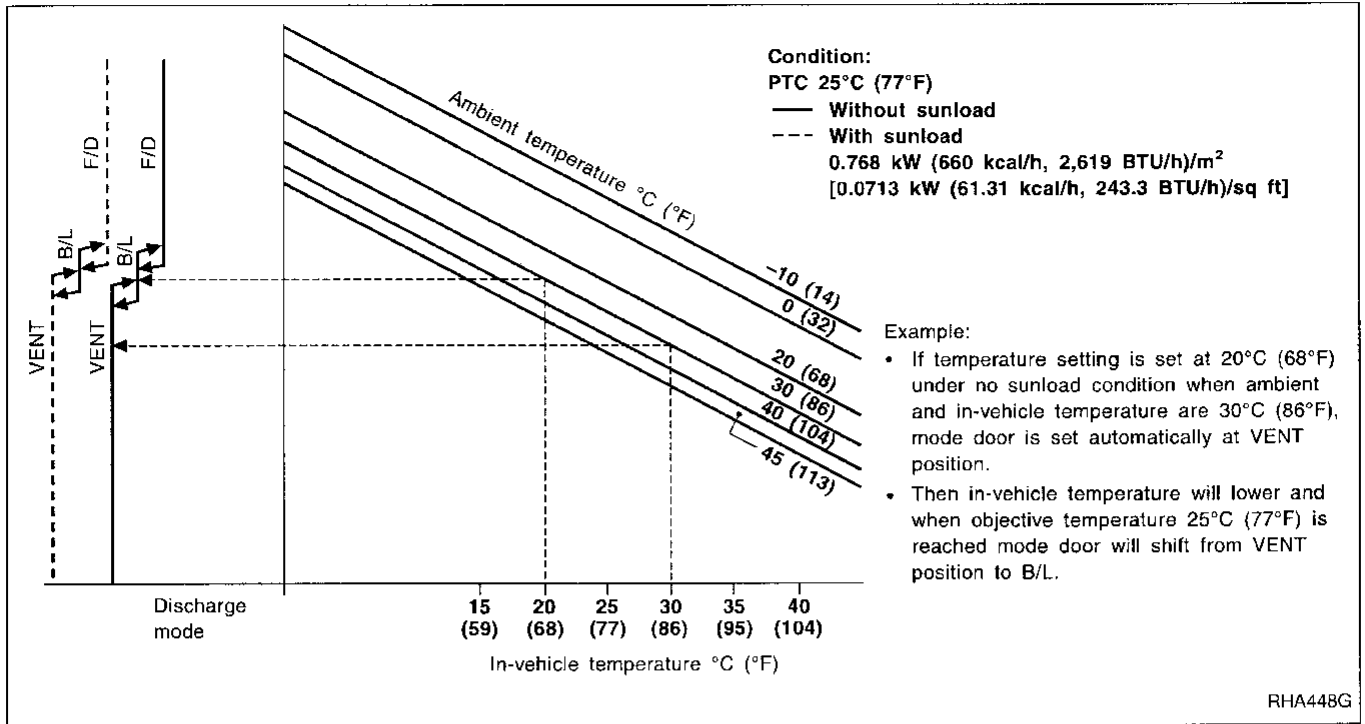

MODE DOOR MOTOR

The mode door motor is attached to the heater unit. It rotates so that air is discharged from the outlet set by the auto amp. Motor rotation is conveyed to a link which activates the mode door.

9	8	Mode door operation	Direction of side link rotation
⊕	⊖	VENT → DEF	Clockwise
—	—	STOP	STOP
⊖	⊕	DEF → VENT	Counterclockwise

GI

MA

EM

LC

EC

FE

CL

MT

AT

FA

RA

BR

ST

RS

BT

HA

EL

IDX

SYSTEM DESCRIPTION

Control System Output Components (Cont'd)

INTAKE DOOR CONTROL

Components parts

Intake door control system components are:

- 1) Auto amp.
- 2) Intake door motor
- 3) PBR
- 4) In-vehicle sensor
- 5) Ambient sensor
- 6) Sunload sensor
- 7) Intake sensor

System operation

The intake door control determines intake door position based on the ambient temperature and the in-vehicle temperature. When the ECON, DEF, or OFF buttons are pushed, the auto amp. sets the intake door at the "Fresh" position.

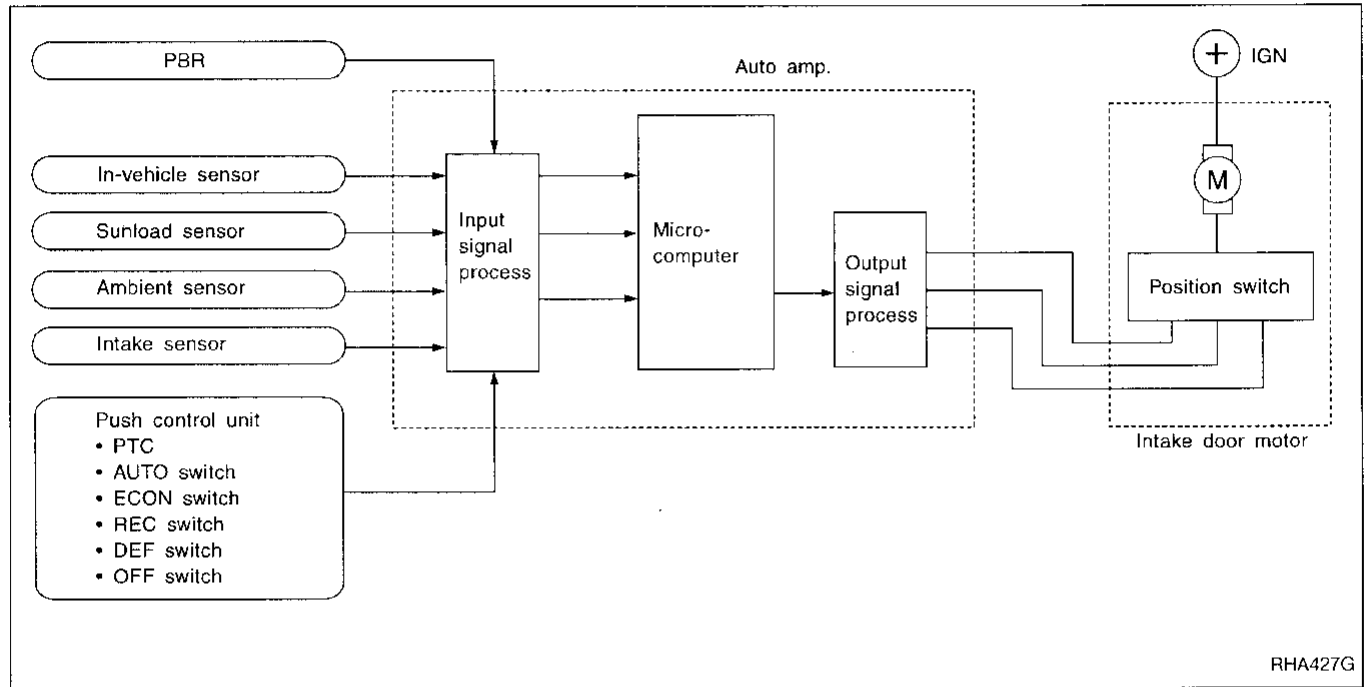

RHA427G

Intake door control specification

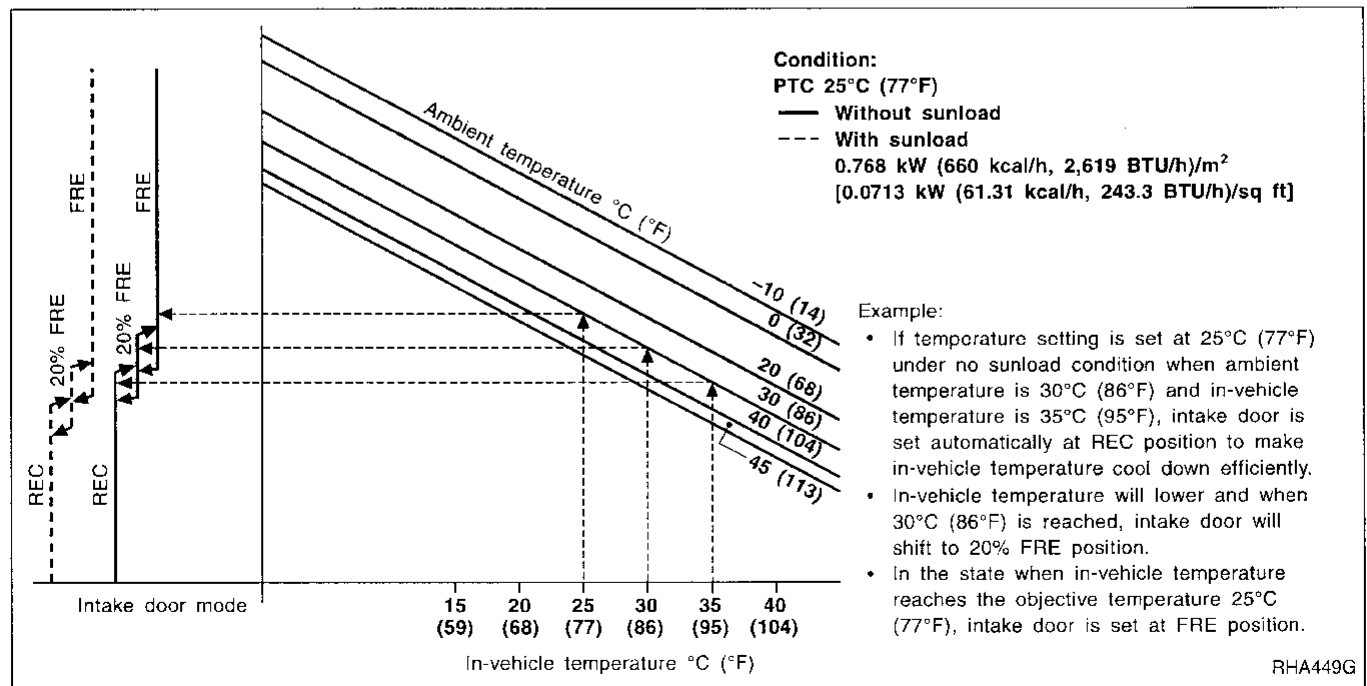

RHA449G

SYSTEM DESCRIPTION

Control System Output Components (Cont'd)

INTAKE DOOR MOTOR

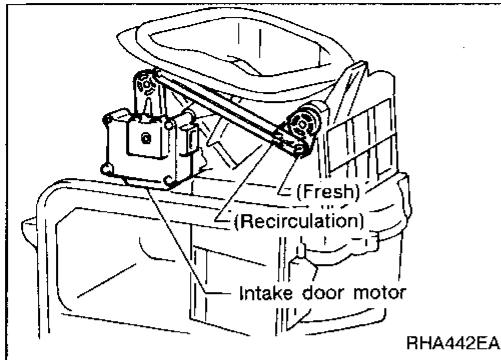

The intake door motor is attached to the intake unit. It rotates so that air is drawn from inlets set by the auto amp. Motor rotation is conveyed to a lever which activates the intake door.

Intake door motor operation

6	7	Intake door operation	Movement of link rotation
⊕	⊖	REC → FRE	Clockwise
—	—	STOP	STOP
⊖	⊕	FRE → REC	Counterclockwise

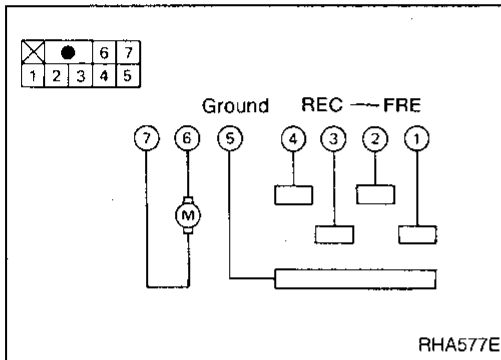

FAN SPEED CONTROL

Component parts

Fan speed control system components are:

- 1) Auto amp.
- 2) Fan control amplifier
- 3) PBR
- 4) In-vehicle sensor
- 5) Ambient sensor
- 6) Sunload sensor
- 7) Intake sensor

System operation

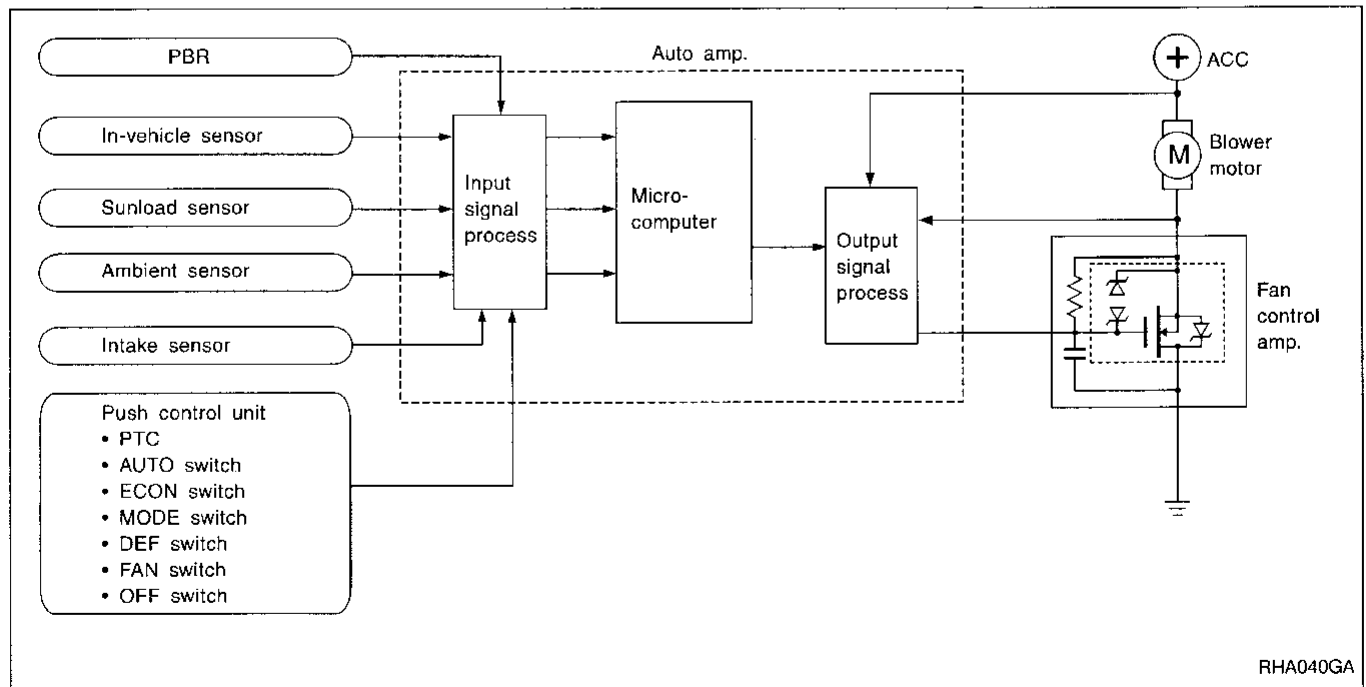

SYSTEM DESCRIPTION

Control System Output Components (Cont'd)

AUTOMATIC MODE

In the automatic mode, the blower motor speed is calculated by the auto amp. based on inputs from the PBR, in-vehicle sensor, sunload sensor, and ambient sensor. The blower motor applied voltage ranges from approximately 4.5 volts (lowest speed) to 12 volts (highest speed).

To control blower speed, the auto amp. supplies a signal (in the range of 2.5V to 9V), to the fan control amplifier. Based on this signal, the fan control amplifier controls the current flow from the blower motor to ground.

STARTING FAN SPEED CONTROL

Start up from "COLD SOAK" condition (Automatic mode)

In a cold start up condition where the engine coolant temperature is below 50°C (122°F), the blower will not operate for a short period of time (up to 150 seconds). The exact start delay time varies depending on the ambient and engine coolant temperature. In the most extreme case (very low ambient) the blower starting delay will be 150 seconds. After this

delay, the blower will operate at low speed until the engine coolant temperature rises above 50°C (122°F). Then the blower speed will increase to the objective speed.

Start up from normal or "HOT SOAK" condition (Automatic mode)

The blower will begin operation momentarily after the AUTO button is pushed. The blower speed will gradually rise to the objective speed over a time period of 5 seconds or less (actual time depends on the objective blower speed).

BLOWER SPEED COMPENSATION

Sunload

When the in-vehicle temperature and the set temperature are very close, the blower will operate at low speed. The low speed varies depending on the sunload. During conditions of high sunload, the blower low speed is "normal" low speed (approx. 5.5V). During lesser sunload conditions, the low speed will drop to "low" low speed (approx. 4.5V).

Fan speed control specification

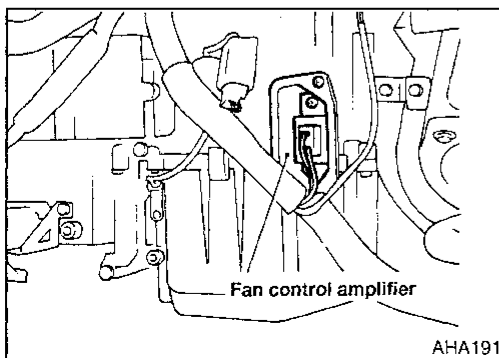
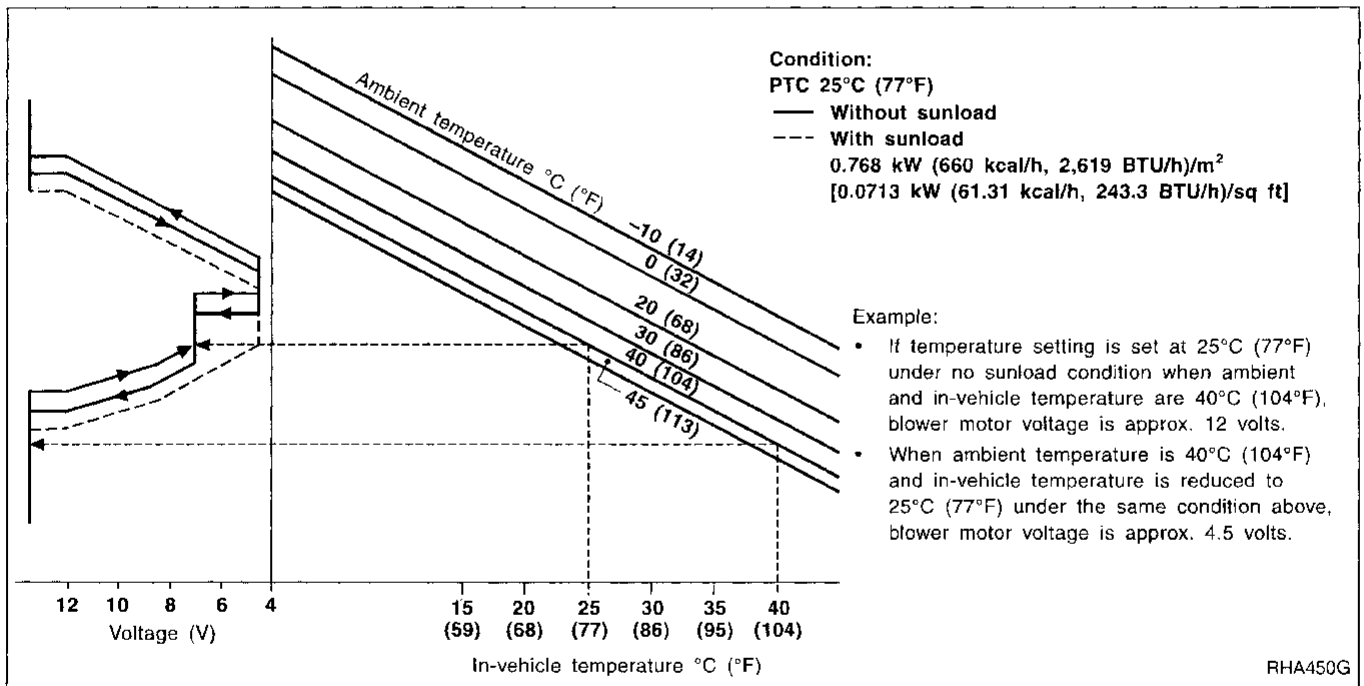

FAN CONTROL AMPLIFIER

The fan control amplifier is located on the cooling unit. It amplifies the base current flowing from the auto amp. to change the blower speed within the range of 4V to 12V.

SYSTEM DESCRIPTION

Control System Output Components (Cont'd) MAGNET CLUTCH CONTROL

The ECM (ECCS control module) controls compressor operation using inputs from the throttle position sensor and auto amplifier.

GI

MA

EM

LC

EC

FE

CL

MT

AT

FA

RA

BR

ST

RS

BT

HA

EL

IDX

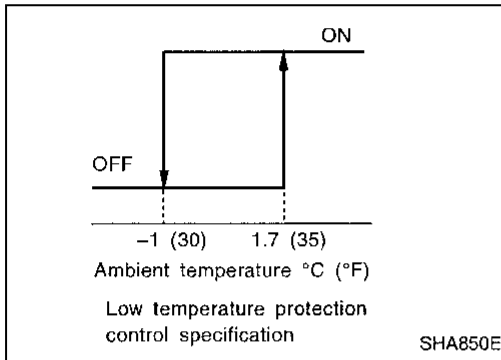

Low temperature protection control

Auto amplifier will turn the compressor "ON" or "OFF" as determined by a signal detected by ambient temperature sensor. The compressor turns "OFF" when ambient temperatures are less than -1°C (30°F).

Acceleration cut control

The ECM (ECCS control module) will turn the compressor "ON" or "OFF" based on the signal from the throttle position sensor.

SERVICE PROCEDURES

HFC-134a (R-134a) Service Procedure

SETTING OF SERVICE TOOLS AND EQUIPMENT

DISCHARGING REFRIGERANT

WARNING:

Avoid breathing A/C refrigerant and lubricant vapor or mist. Exposure may irritate eyes, nose and throat. Remove R-134a from A/C system, using certified service equipment meeting requirements of SAE J2210 (R-134a recycling equipment), or J2209 (R-134a recovery equipment). If accidental system discharge occurs, ventilate work area before resuming service. Additional health and safety information may be obtained from refrigerant and lubricant manufacturers.

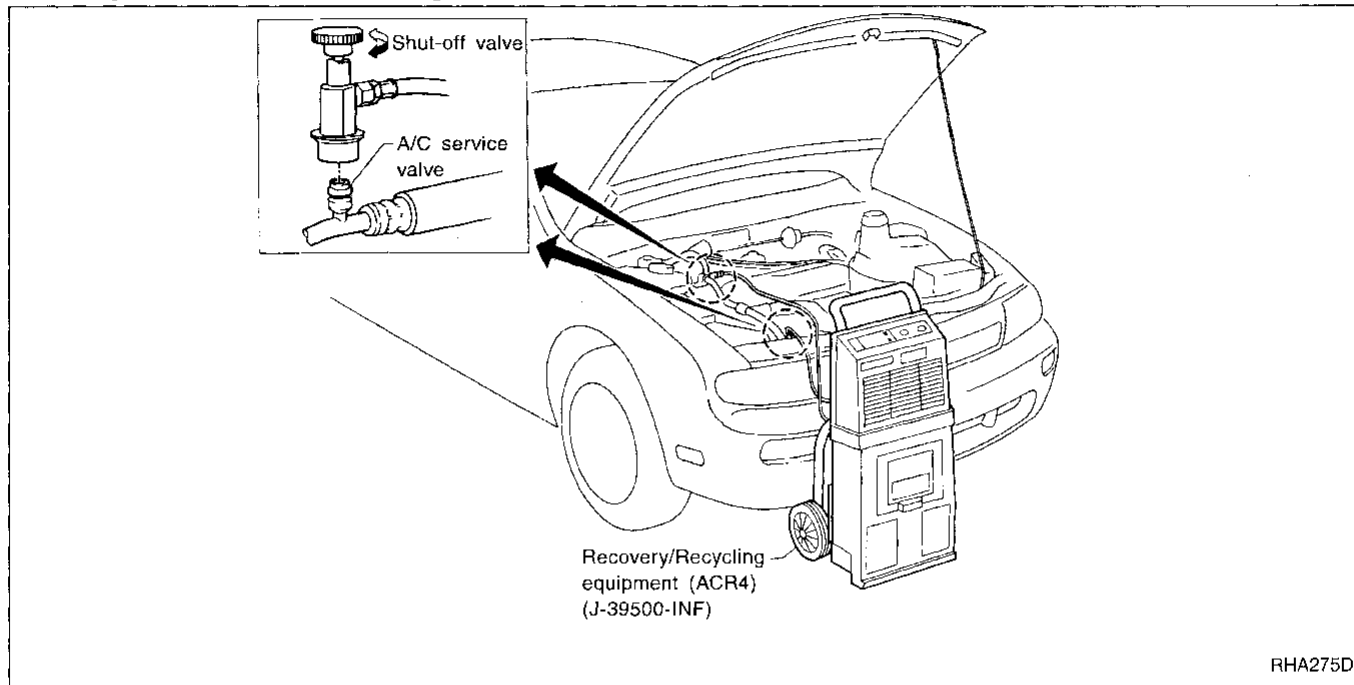

EVACUATING SYSTEM AND CHARGING REFRIGERANT

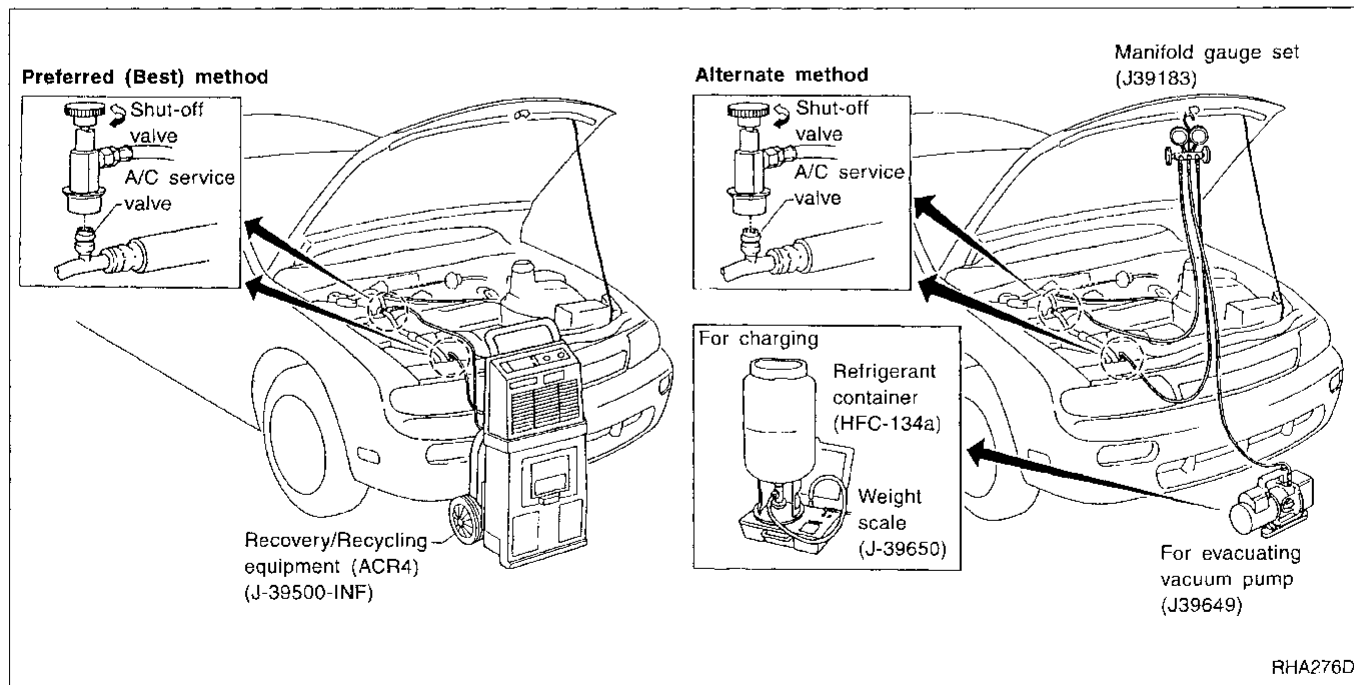

SERVICE PROCEDURES

HFC-134a (R-134a) Service Procedure (Cont'd)

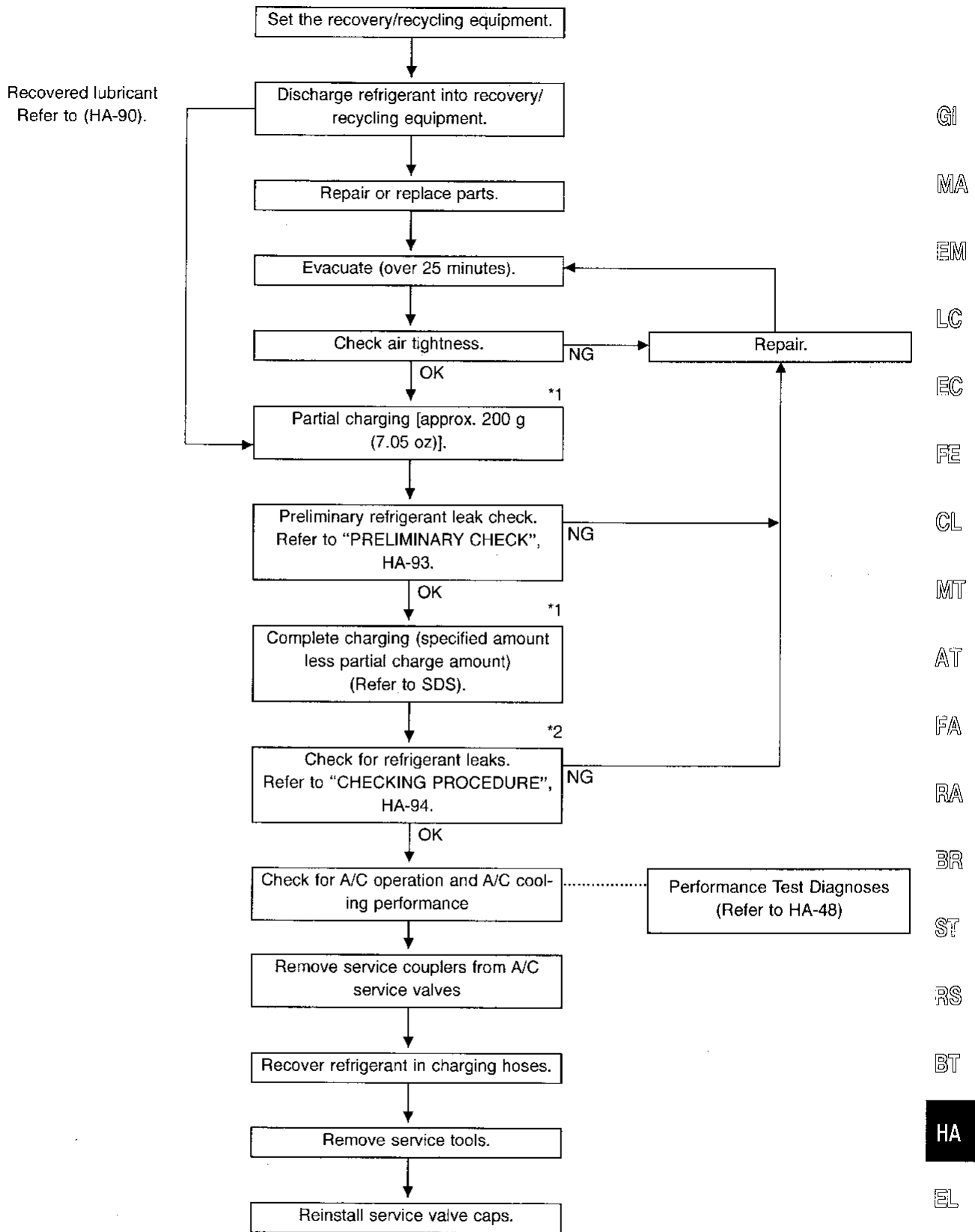

Note: *1 Before charging refrigerant, ensure engine is off.

*2 Before checking for leaks, start engine to activate air conditioning system then turn engine off.
Service valve caps must be installed to prevent leakage.

Maintenance of Lubricant Quantity in Compressor

The lubricant in the compressor circulates through the system with the refrigerant. Add lubricant to compressor when replacing any component or after a large gas leakage occurred. It is important to maintain the specified amount.

If lubricant quantity is not maintained properly, the following malfunctions may result:

- Lack of lubricant: May lead to a seized compressor
- Excessive lubricant: Inadequate cooling (thermal exchange interference)

LUBRICANT

Name: Nissan A/C System Oil Type S

Part number: KLH00-PAGS0

CHECKING AND ADJUSTING

Adjust the lubricant quantity according to the flowchart shown below.

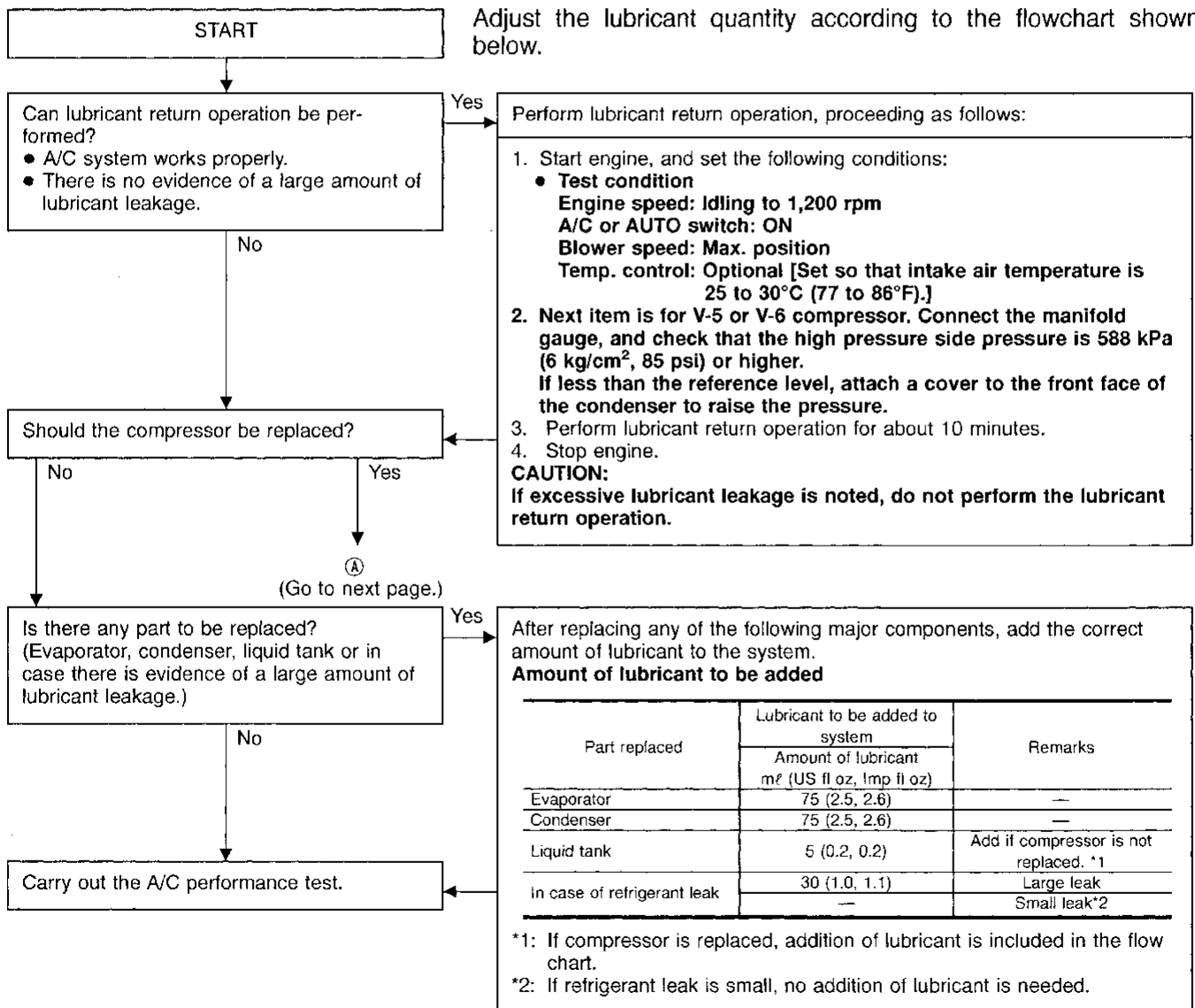

SERVICE PROCEDURES

Maintenance of Lubricant Quantity in Compressor (Cont'd)

Ⓐ

1. Discharge refrigerant into the refrigerant recovery/recycling equipment. Measure lubricant discharged into the recovery/recycling equipment.
2. Remove the drain plug of the "old" (removed) compressor (applicable only to V-5, V-6 or DKS-16H compressor). Drain the lubricant into a graduated container and record the amount of drained lubricant.
3. Remove the drain plug and drain the lubricant from the "new" compressor into a separate, clean container.
4. Measure an amount of new lubricant installed equal to amount drained from "old" compressor. Add this lubricant to "new" compressor through the suction port opening.
5. Measure an amount of new lubricant equal to the amount recovered during discharging. Add this lubricant to "new" compressor through the suction port opening.
6. Torque the drain plug.

V-5 or V-6 compressor: 18 - 19 N-m (1.8 - 1.9 kg-m, 13 - 14 ft-lb)

DKS-16H compressor: 14 - 16 N-m (1.4 - 1.6 kg-m, 10 - 12 ft-lb)

7. If the liquid tank also needs to be replaced, add an additional 5 ml (0.2 US fl oz, 0.2 Imp fl oz) of lubricant at this time.

Do not add this 5 ml (0.2 US fl oz, 0.2 Imp fl oz) of lubricant if only replacing the compressor.

Lubricant adjusting procedure for compressor replacement

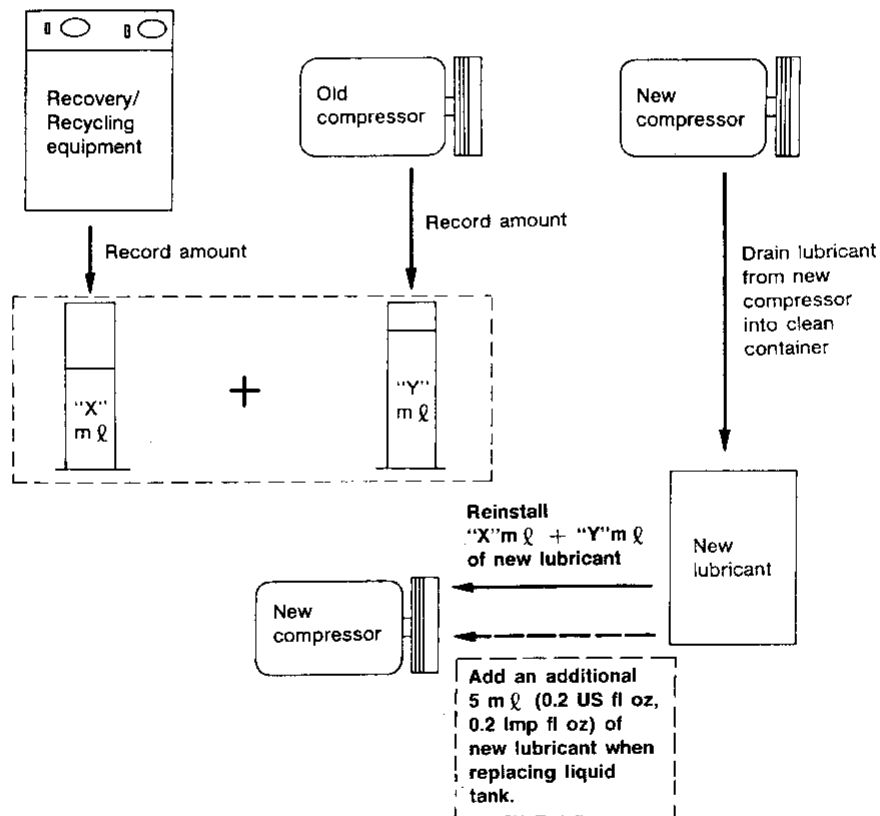

RHA065DD

GI

MA

EM

LC

EC

FE

CL

MT

AT

FA

RA

BR

ST

RS

BT

HA

EL

IDX

SERVICE PROCEDURES

Refrigerant Lines

- Refer to Precautions for Refrigerant Connection (HA-3).

SEC. 271•274•276

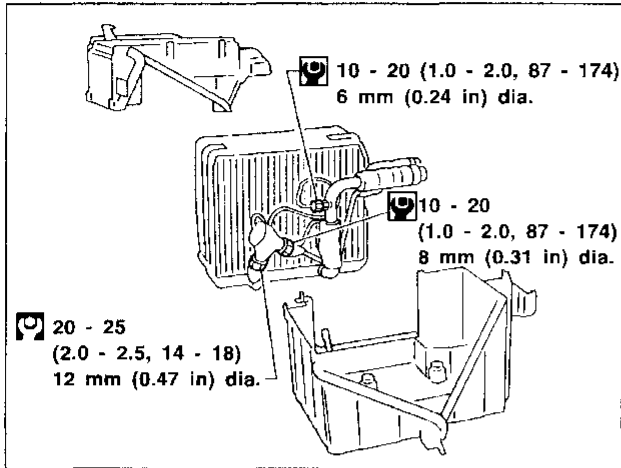

(k) Low-pressure (Suction) service valve

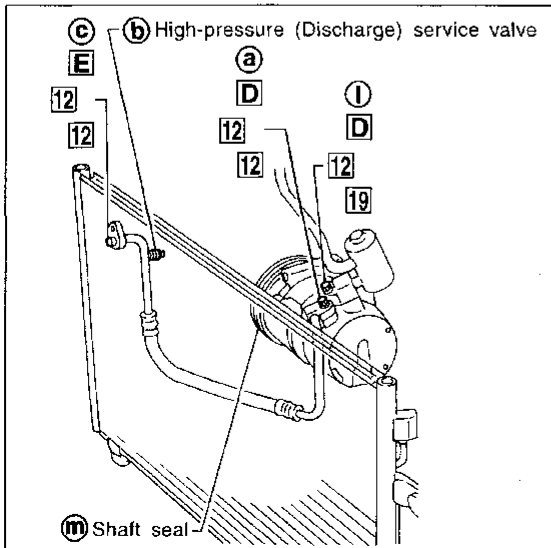
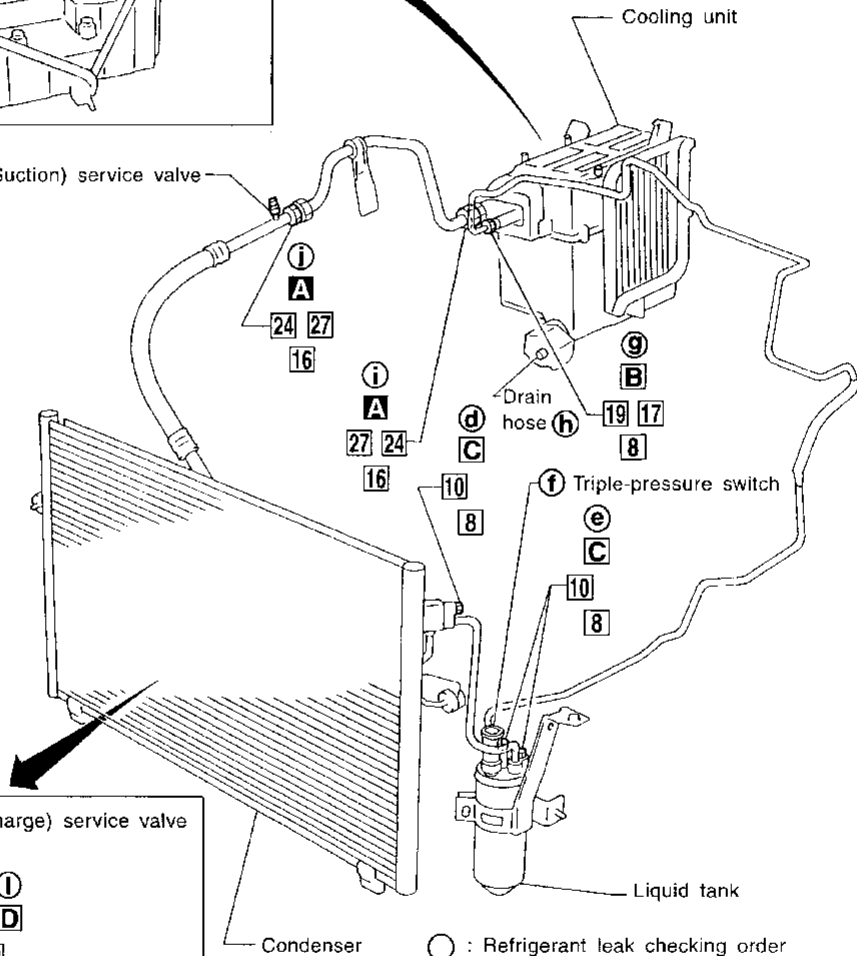

- : Refrigerant leak checking order
- (Tightening torque)
- (Wrench size)
- (O-ring size)
- Ⓜ : N·m (kg-m, ft-lb)
- Ⓐ : 20 - 29 (2.0 - 3.0, 14 - 22)
- Ⓜ : N·m (kg-m, in-lb)
- Ⓑ : 3.8 - 4.5 (0.39 - 0.46, 33.9 - 39.9)
- Ⓒ : 3 - 4 (0.3 - 0.4, 26 - 35)
- Ⓓ : 8 - 11 (0.8 - 1.1, 69 - 95)
- Ⓔ : 9.3 - 10.8 (0.95 - 1.1, 82.5 - 95.5)

SHA875E

Checking Refrigerant Leaks

PRELIMINARY CHECK

Perform a visual inspection of all refrigeration parts, fittings, hoses, and components for signs of A/C lubricant leakage, damage and corrosion.

GI

MA

EM

LC

EC

FE

CL

MT

AT

FA

RA

BR

ST

RS

BT

HA

EL

IDX

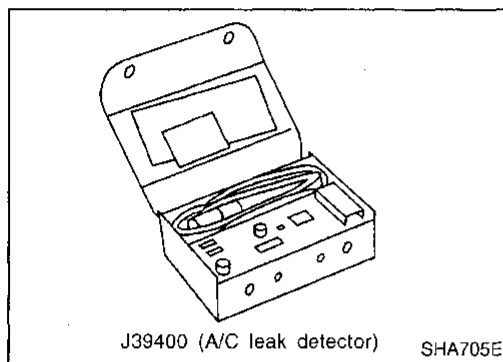

PRECAUTIONS FOR HANDLING LEAK DETECTOR

When performing a refrigerant leak check, use a J39400 A/C leak detector or equivalent. Ensure that the instrument is calibrated and set properly per the operating instructions.

The leak detector is a delicate device. In order to use the leak detector properly, read the operating instructions and perform any specified maintenance.

Other gases in the work area or substances on the A/C components, for example, anti-freeze, windshield washer fluid, solvents and cleaners, may falsely trigger the leak detector. Make sure the surfaces to be checked are clean. Do not allow the sensor tip of the detector to come into contact with any substance. This can also cause false readings and may damage the detector.

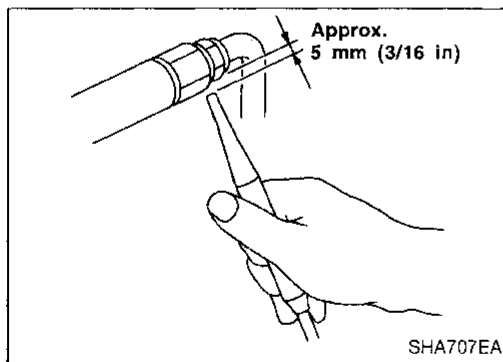

1. Position probe approximately 5 mm (3/16 in) away from point to be checked.

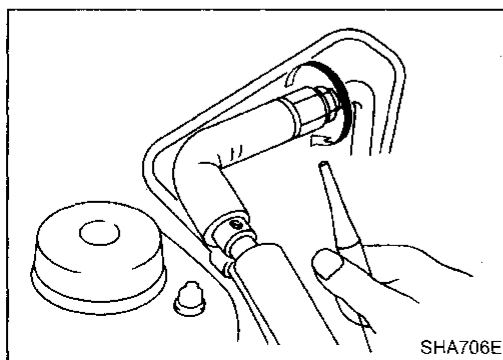

2. When testing, circle each fitting completely with probe.

SERVICE PROCEDURES

Checking Refrigerant Leaks (Cont'd)

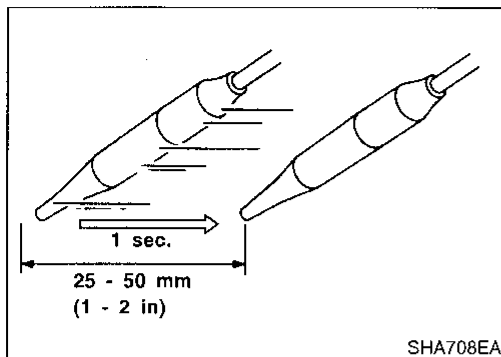

3. Move probe along component approximately 25 to 50 mm (1 to 2 in)/sec.

CHECKING PROCEDURE

To prevent inaccurate or false readings, make sure there is no refrigerant vapor or tobacco smoke in the vicinity of the vehicle. Perform the leak test in calm area (low air/wind movement) so that the leaking refrigerant is not dispersed.

1. Turn engine off.
2. Connect a suitable A/C manifold gauge set to the A/C service ports.
3. Check if the A/C refrigerant pressure is at least 345 kPa (3.52 kg/cm², 50 psi) above 16°C (61°F). If less than specification, evacuate and recharge the system with the specified amount of refrigerant.

NOTE: At temperatures below 16°C (61°F), leaks may not be detected since the system may not reach 345 kPa (3.52 kg/cm², 50 psi).

4. Conduct the leak test from the high side to the low side at points (a) through (m). Refer to HA-92.
Perform a leak check for the following areas carefully. Clean the component to be checked and move the leak detector probe completely around the connection/component.

- **Compressor**

Check the fitting of high and low pressure hoses, relief valve and shaft seal.

- **Liquid tank**

Check the pressure switch, tube fitting, weld seams and the fusible plug mounts.

- **Service valves**

Check all around the service valves. Ensure service valve caps are secured on the service valves (to prevent leaks).

NOTE: After removing A/C manifold gauge set from service valves, wipe any residue from valves to prevent any false readings by leak detector.

- **Cooling unit (Evaporator)**

Turn blower fan on "High" for at least 15 seconds to dissipate any refrigerant trace in the cooling unit. Insert the leak detector probe into the drain hose immediately after stopping the engine. (Keep the probe inserted for at least ten seconds.)

5. If a leak detector detects a leak, verify at least once by blowing compressed air into area of suspected leak, then repeat check.
6. Do not stop when one leak is found. Continue to check for additional leaks at all system components.
7. Start engine.
8. Set the heater A/C control as follows:
 - a. A/C switch ON
 - b. Face mode
 - c. Recirculation switch ON

HA-94

SERVICE PROCEDURES

Checking Refrigerant Leaks (Cont'd)

- d. Max cold temperature
- e. Fan speed high
9. Run engine at 1500 rpm for at least 2 minutes.
10. Turn engine off and perform leak check again following steps 4 through 6 above.

GI

MA

EM

LC

EC

FE

CL

MT

AT

FA

RA

BR

ST

RS

BT

HA

EL

IDX

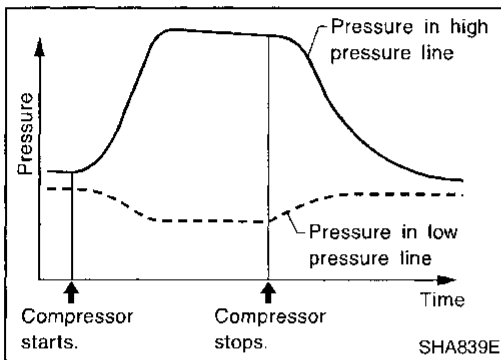

Refrigerant leaks should be checked immediately after stopping the engine. Begin with the leak detector on the high pressure line. The pressure in the high pressure line will gradually drop after refrigerant circulation stops and pressure in the low pressure line will gradually rise, as shown in the graph. Leaks are more easily detected when pressure is high.

11. Discharge A/C system using approved refrigerant recovery equipment. Repair the leaking fitting or component as necessary.
12. Evacuate and recharge A/C system and perform the leak test to confirm no refrigerant leaks.
13. Conduct A/C performance test to ensure system works properly.

Compressor Mounting

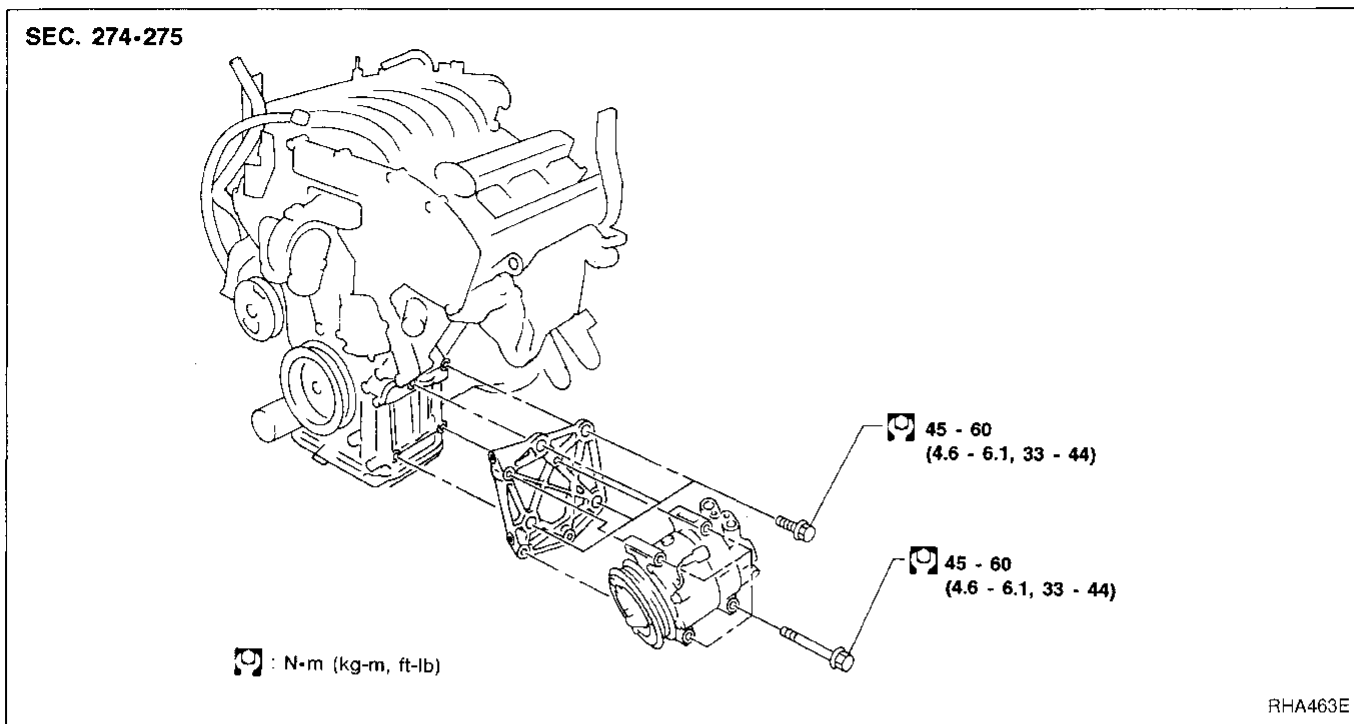

Belt Tension

- Refer to MA section ("Checking Drive Belts", "ENGINE MAINTENANCE").

Fast Idle Control Device (FICD)

- Refer to EC section ("IACV-FICD SOLENOID VALVE", "TROUBLE DIAGNOSES FOR NON-DETECTIVE ITEMS").

Compressor

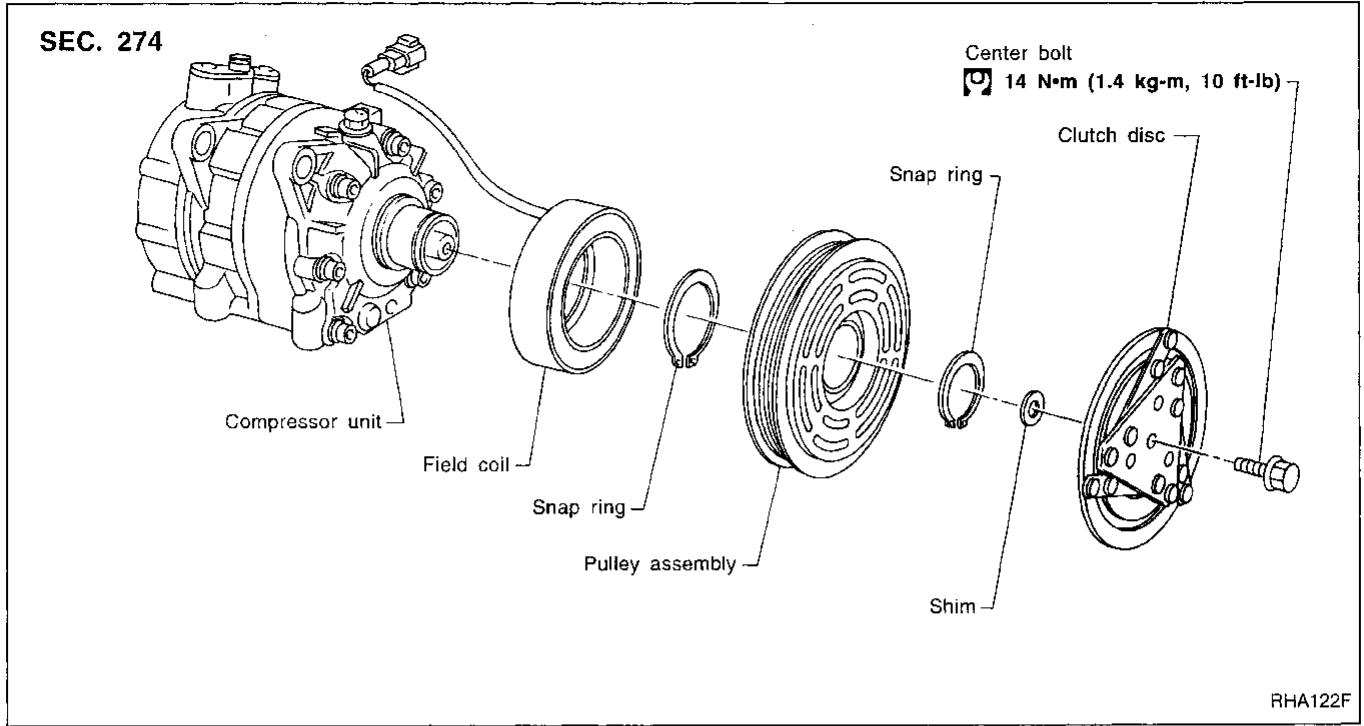

GI
 MA
 EM
 LC
 EC
 FE
 CL
 MT
 AT
 FA
 RA
 BR
 ST
 RS
 BT
 HA
 EL
 IDX

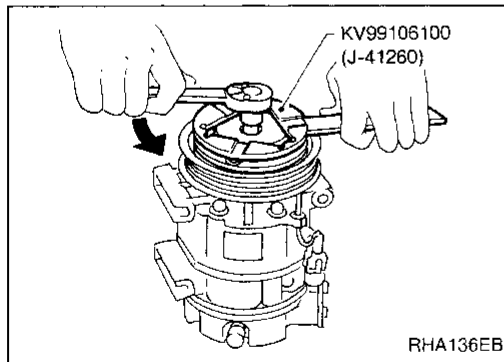

Compressor Clutch

REMOVAL

- When removing center bolt, hold clutch disc with clutch disc wrench.

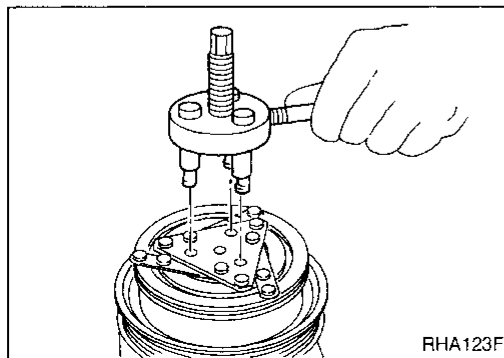

SERVICE PROCEDURES

Compressor Clutch (Cont'd)

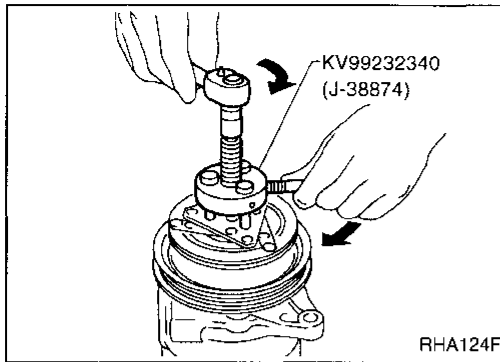

- Remove the clutch disc using the clutch disc puller. Insert the holder's three pins into the holes in the clutch disc. Rotate the holder clockwise to hook it onto the plate. Then, tighten the center bolt to remove the clutch disc. After removing the clutch disc, remove the shims from either the drive shaft or the clutch disc.

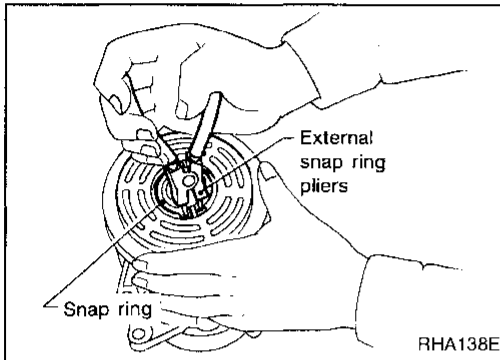

- Remove the snap ring using external snap ring pliers.

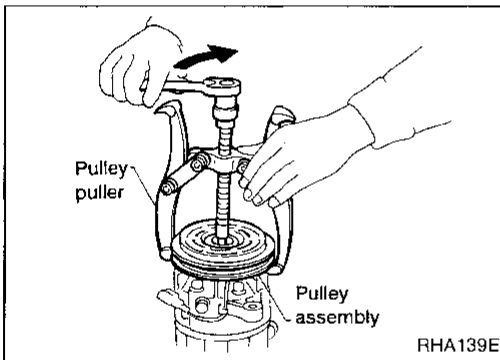

- Pulley removal
Position the center pulley puller on the end of the drive shaft, and remove the pulley assembly using any commercially available pulley puller.
To prevent the pulley groove from being deformed, the puller claws should be positioned onto the edge of the pulley assembly.

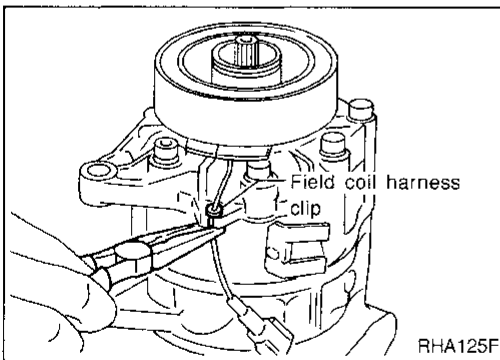

- Remove the field coil harness clip using a pair of pliers.

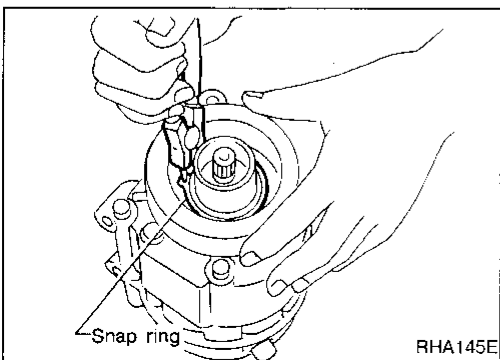

- Remove the snap ring using external snap ring pliers.

SERVICE PROCEDURES

Compressor Clutch (Cont'd)

INSPECTION

Clutch disc

If the contact surface shows signs of damage due to excessive heat, replace clutch disc and pulley.

Pulley

Check the appearance of the pulley assembly. If the contact surface of pulley shows signs of excessive grooving, replace clutch disc and pulley. The contact surfaces of the pulley assembly should be cleaned with a suitable solvent before reinstallation.

Coil

Check clubricant for loose connection or cracked insulation.

INSTALLATION

- Install the field coil.

Be sure to align the coil's pin with the hole in the compressor's front head.

- Install the field coil harness clip using a screwdriver.

- Install the pulley assembly using the installer and a hand press, and then install the snap ring using snap ring pliers.

- Install the clutch disc on the drive shaft, together with the original shim(s). Press the clutch disc down by hand.

- Using the holder to prevent clutch disc rotation, tighten the bolt to 14 N·m (1.4 kg-m, 10 ft-lb) torque.

After tightening the bolt, check that the pulley rotates smoothly.

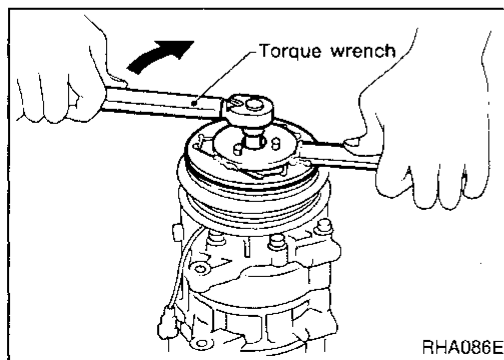
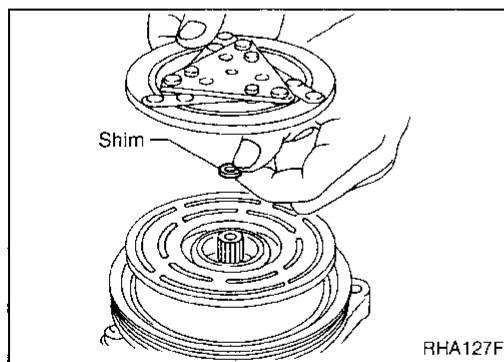
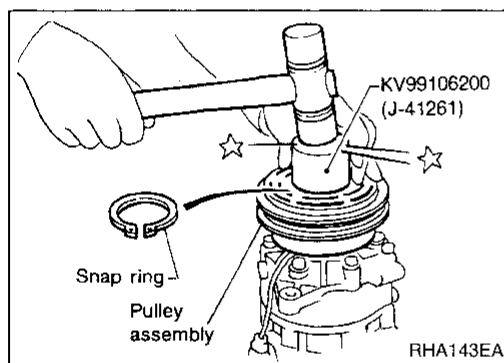
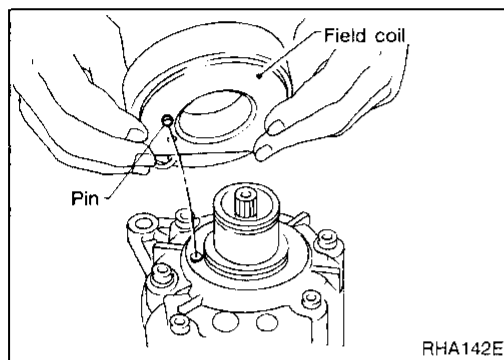
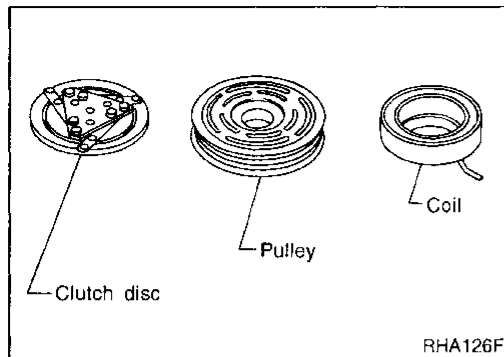

GI

MA

EM

LC

EC

FE

CL

MT

AT

FA

RA

BR

ST

RS

BT

HA

EL

IDX

SERVICE PROCEDURES

Compressor Clutch (Cont'd)

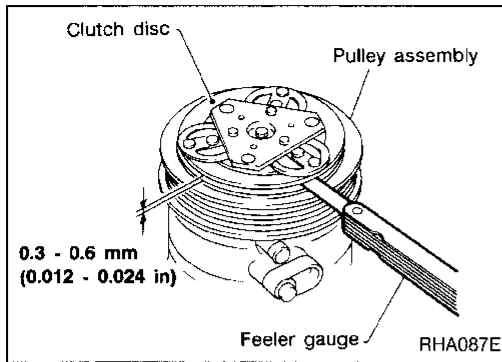

- Check clearance around the entire periphery of clutch disc.

Disc-to-pulley clearance:

0.3 - 0.6 mm (0.012 - 0.024 in)

If the specified clearance is not obtained, replace adjusting spacer and readjust.

BREAK-IN OPERATION

When replacing compressor clutch assembly, always carry out the break-in operation. This is done by engaging and disengaging the clutch about thirty times. Break-in operation raises the level of transmitted torque.

SERVICE DATA AND SPECIFICATIONS (SDS)

General Specifications

COMPRESSOR

Model	CALSONIC make V-6	
Type	V-6 variable displacement	
Displacement	cm ³ (cu in)/rev.	
Max.		184 (11.228)
Min.		10.5 (0.641)
Cylinder bore x stroke	mm (in)	37 (1.46) x [1.6 - 28.6 (0.063 - 1.126)]
Direction of rotation	Clockwise (viewed from drive end)	
Drive belt	Poly V	

LUBRICANT

Model	CALSONIC make V-6	
Name	Nissan A/C System Oil Type S	
Part number	KLH00-PAGS0	
Capacity	ml (US fl oz, Imp fl oz)	
Total in system		200 (6.8, 7.0)
Compressor (Service part) charging amount		200 (6.8, 7.0)

REFRIGERANT

Type	HFC-134a (R-134a)	
Capacity	kg (lb)	0.65±0.05 (1.43±0.11)

Inspection and Adjustment

ENGINE IDLING SPEED (When A/C is ON)

- Refer to EC section.

BELT TENSION

- Refer to MA section ("Checking Drive Belts").

GI

MA

EM

LC

EC

FE

CL

MT

AT

FA

RA

BR

ST

RS

BT

HA

EL

IDX