

# RESTRAINT SYSTEM

## SECTION **RS**

### CONTENTS

<b>PRECAUTION</b> .....	2	Removal — Air Bag Module and Spiral Cable.....	9
Supplemental Restraint System (SRS) "AIR BAG".....	2	Removal — Front Passenger Air Bag Module.....	10
<b>SEAT BELTS</b> .....	3	Installation — Air Bag Module and Spiral Cable.....	11
Front Seat Belt.....	3	Installation — Front Passenger Air Bag Module.....	12
Rear Seat Belt.....	4	Disposal of Air Bag Module.....	13
<b>SUPPLEMENTAL RESTRAINT SYSTEM (SRS)</b> .....	5	<b>TRouble DIAGNOSES — Supplemental Restraint System (SRS)</b> .....	17
Precautions for SRS "Air Bag" Service.....	5	How to Perform Trouble Diagnoses for Quick and Accurate Repair.....	17
Special Service Tools.....	5	Schematic.....	19
Description.....	6	Wiring Diagram — SRS —.....	20
SRS Component Parts Location.....	6	Self-diagnosis.....	22
Maintenance Items.....	7	Trouble Diagnoses for Air Bag Warning Lamp.....	34
Removal and Installation — Diagnosis Sensor Unit.....	8	<b>COLLISION DIAGNOSIS</b> .....	36
Removal and Installation — Air Bag Module and Spiral Cable.....	8		

**When you read wiring diagrams:**

- Read G1 section, "HOW TO READ WIRING DIAGRAMS".
- See EL section, "POWER SUPPLY ROUTING" for power distribution circuit.

**When you perform trouble diagnoses, read G1 section, "HOW TO FOLLOW FLOW CHART IN TROUBLE DIAGNOSES" and "HOW TO PERFORM EFFICIENT DIAGNOSIS FOR AN ELECTRICAL INCIDENT".**

GI  
MA  
EM  
LC  
EC  
FE  
CL  
MT  
AT  
FA  
RA  
BR  
ST  
RS  
BT  
HA  
EL  
IDX

## PRECAUTION

---

### **Supplemental Restraint System (SRS) "AIR BAG"**

The Supplemental Restraint System "Air Bag", used along with a seat belt, helps to reduce the risk or severity of injury to the driver and front passenger in a frontal collision. The Supplemental Restraint System consists of air bag modules (located in the center of the steering wheel and on the instrument panel on the passenger side), a diagnosis sensor unit, warning lamp, wiring harness and spiral cable.

**WARNING:**

- **To avoid rendering the SRS inoperative, which could increase the risk of personal injury or death in the event of a collision which would result in air bag inflation, all maintenance must be performed by an authorized INFINITI dealer.**
- **Improper maintenance, including incorrect removal and installation of the SRS, can lead to personal injury caused by unintentional activation of the system.**
- **All SRS electrical connectors are covered with yellow outer insulation. Do not use electrical test equipment on any circuit related to the SRS.**

# SEAT BELTS

## CAUTION:

- Do not disassemble buckle or seat belt assembly.
- Replace anchor bolts if they are deformed or worn out.
- Never oil tongue and buckle.
- If any component of seat belt assembly is questionable, do not repair. Replace the whole seat belt assembly.
- If webbing is cut, frayed, or damaged, replace seat belt assembly.
- When replacing seat belt assembly, use a genuine seat belt assembly.
- After any collision, inspect all seat belt assemblies, including retractors and other attached hardware (i.e., guide rail set).

## Front Seat Belt

- ① Remove front seat. Refer to "SEAT" in BT section for details.
- ② Remove adjuster cover.
- ③ Slide the floor anchor cover.
- ④ Remove floor anchor bolt.
- ⑤ Remove shoulder anchor bolt.
- ⑥ Remove center pillar upper and lower garnish. Refer to "INTERIOR TRIM" in BT section for details.
- ⑦ Remove the bolt securing seat belt retractor, then remove seat belt and seat belt retractor.
- ⑧ Remove bolts securing seat belt adjuster, then remove seat belt adjuster.

### SEC. 769-868

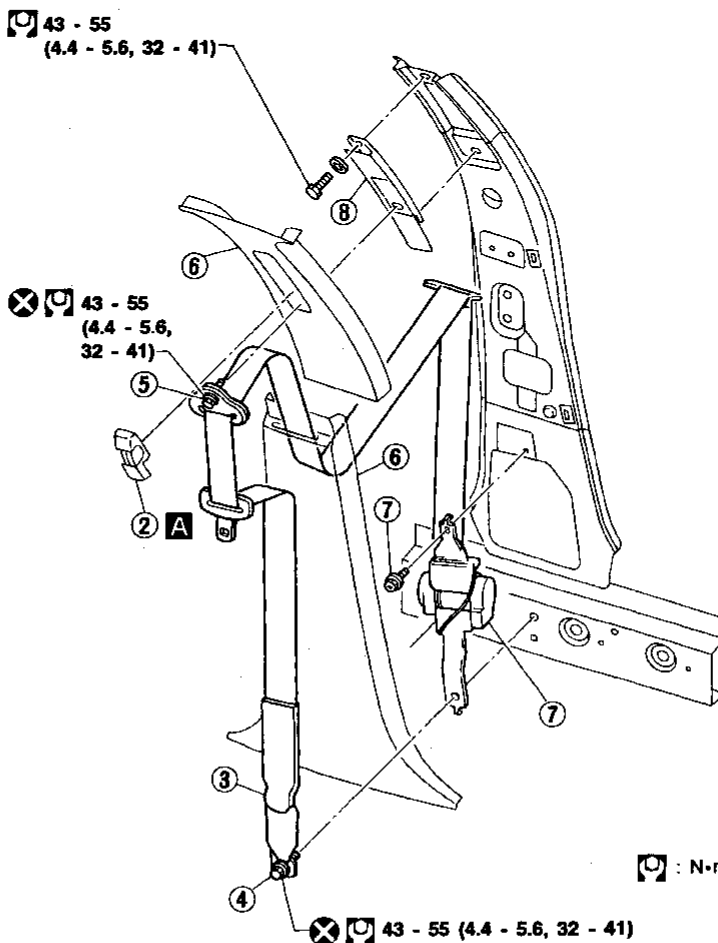
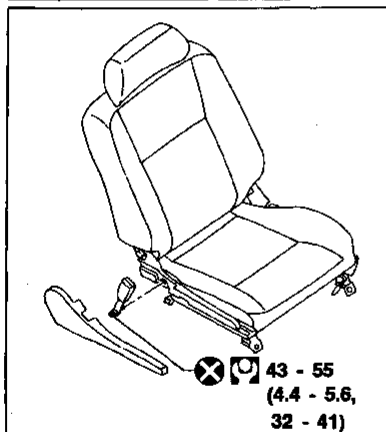
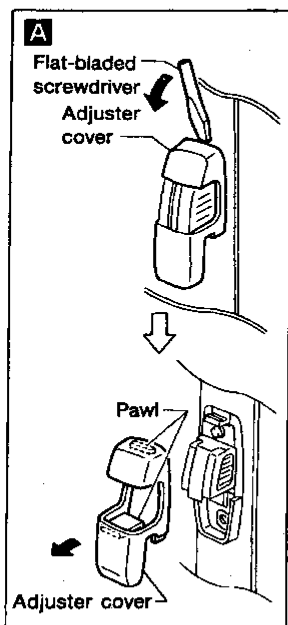

# SEAT BELTS

## Rear Seat Belt

- ① Remove rear seat. Refer to "SEAT" in BT section for details.
- ② Remove rear pillar garnish. Refer to "INTERIOR TRIM" in BT section for details.
- ③ Remove each anchor bolt.
- ④ Remove second sash guide.
- ⑤ Remove the bolt securing rear seat belt retractor, then remove seat belt retractor.

SEC. 869

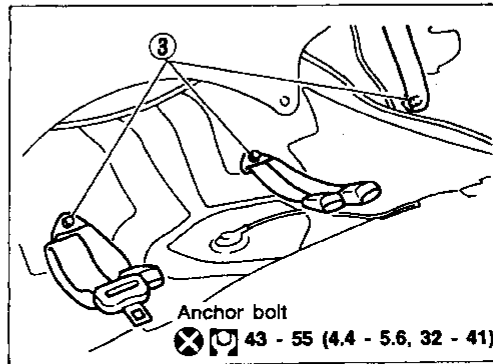
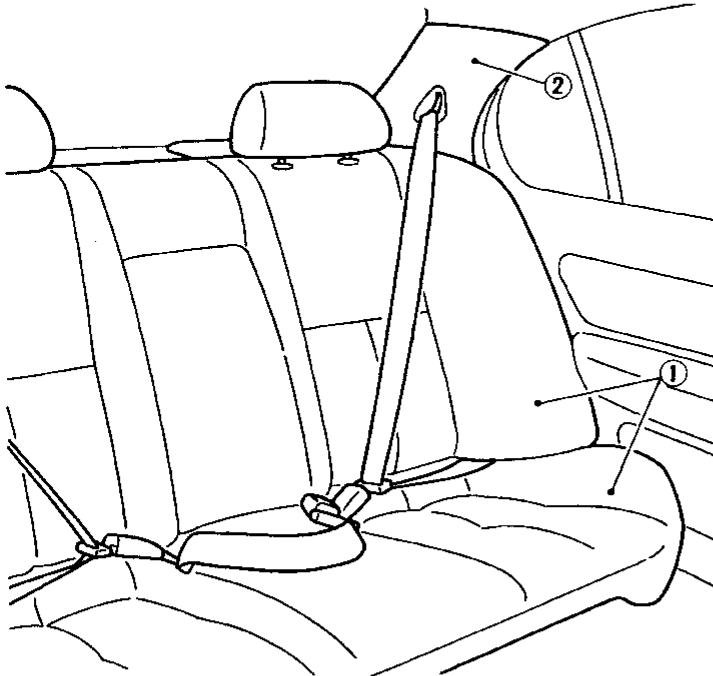
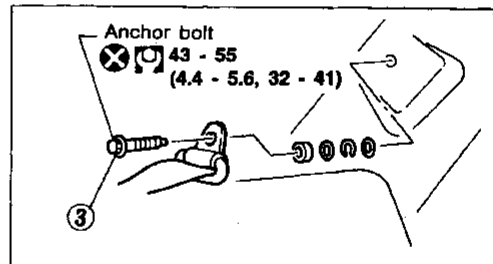
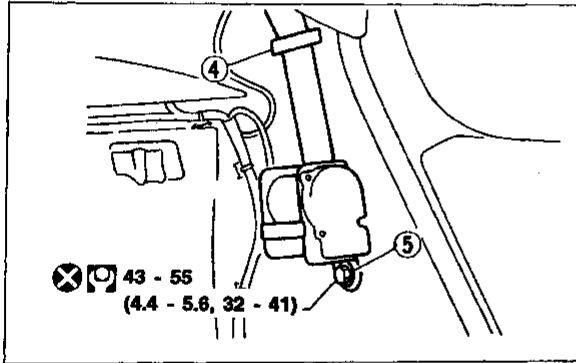

⊞: N·m (kg·m, ft·lb)

MRS033AA

# SUPPLEMENTAL RESTRAINT SYSTEM (SRS)

## Precautions for SRS "Air Bag" Service

- Do not use a circuit tester to check SRS circuits unless instructed to in this Service Manual.
- Before servicing the SRS, turn ignition switch "OFF", disconnect both battery cables and wait for at least 3 minutes.  
For approximately 3 minutes after the cables are removed, it is still possible for the air bag to deploy. Therefore, do not work on any SRS connectors or wires until at least 3 minutes have passed.
- Diagnosis sensor unit must always be installed with arrow marks "Q" pointing towards the front of the vehicle for proper operation. Also check diagnosis sensor unit for cracks, deformities or rust before installation and replace as required.
- The spiral cable must be aligned with the neutral position since its rotations are limited. Do not attempt to turn steering wheel or column after removal of steering gear.
- Handle air bag module carefully. Always place it with the pad side facing upward.
- Conduct self-diagnosis to check entire SRS for proper function after replacing any components.
- After air bag inflates, the front instrument panel assembly should be replaced if damaged.

## Special Service Tools

The actual shapes of Kent-Moore tools may differ from those of special service tools illustrated here.

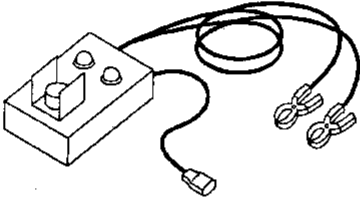
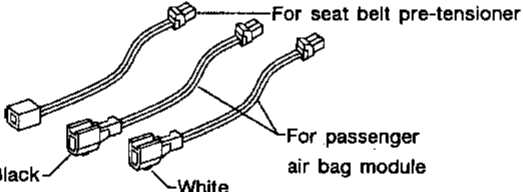
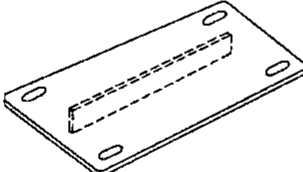
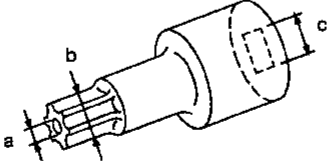
Tool number (Kent-Moore No.) Tool name	Description	
KV991072S0 (J38381-KIT) Air bag deployment kit  KV99106400 (J38381) Deployment tool		Disposing of air bag module
KV991065S0 (J38381-30) Deployment tool adapters		
KV99105300 (J41246) Air bag module bracket		Anchoring air bag module
HT61961000 and HT62152000 combined (J38219) *Special torx bit		Use for special bolts [TAMPER RESISTANT TORX (Size T50)]  a: 3.5 (0.138) dia. b: 8.5 - 8.6 (0.335 - 0.339) dia. c: approx. 10 (0.39) sq.

\*: Special tool or commercial equivalent

# SUPPLEMENTAL RESTRAINT SYSTEM (SRS)

## Description

The air bag deploys if the diagnosis sensor unit activates while the ignition switch is in the "ON" or "START" position.

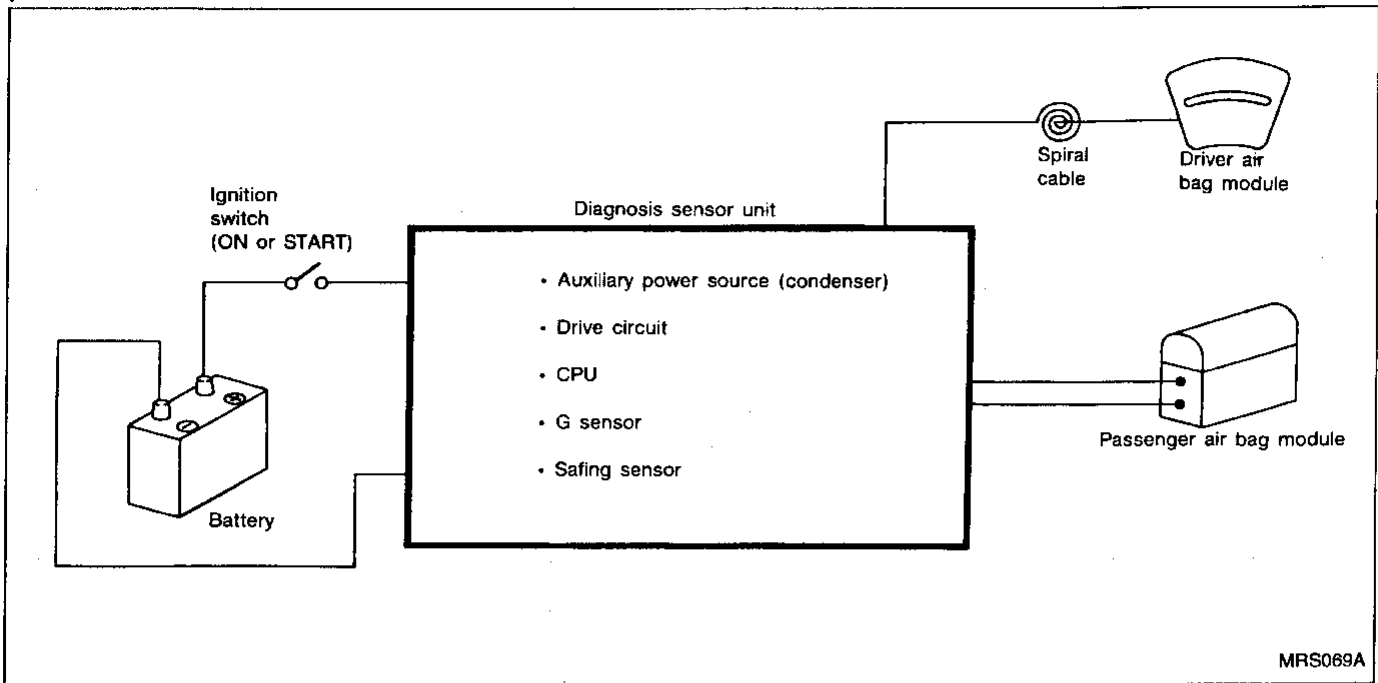

## SRS Component Parts Location

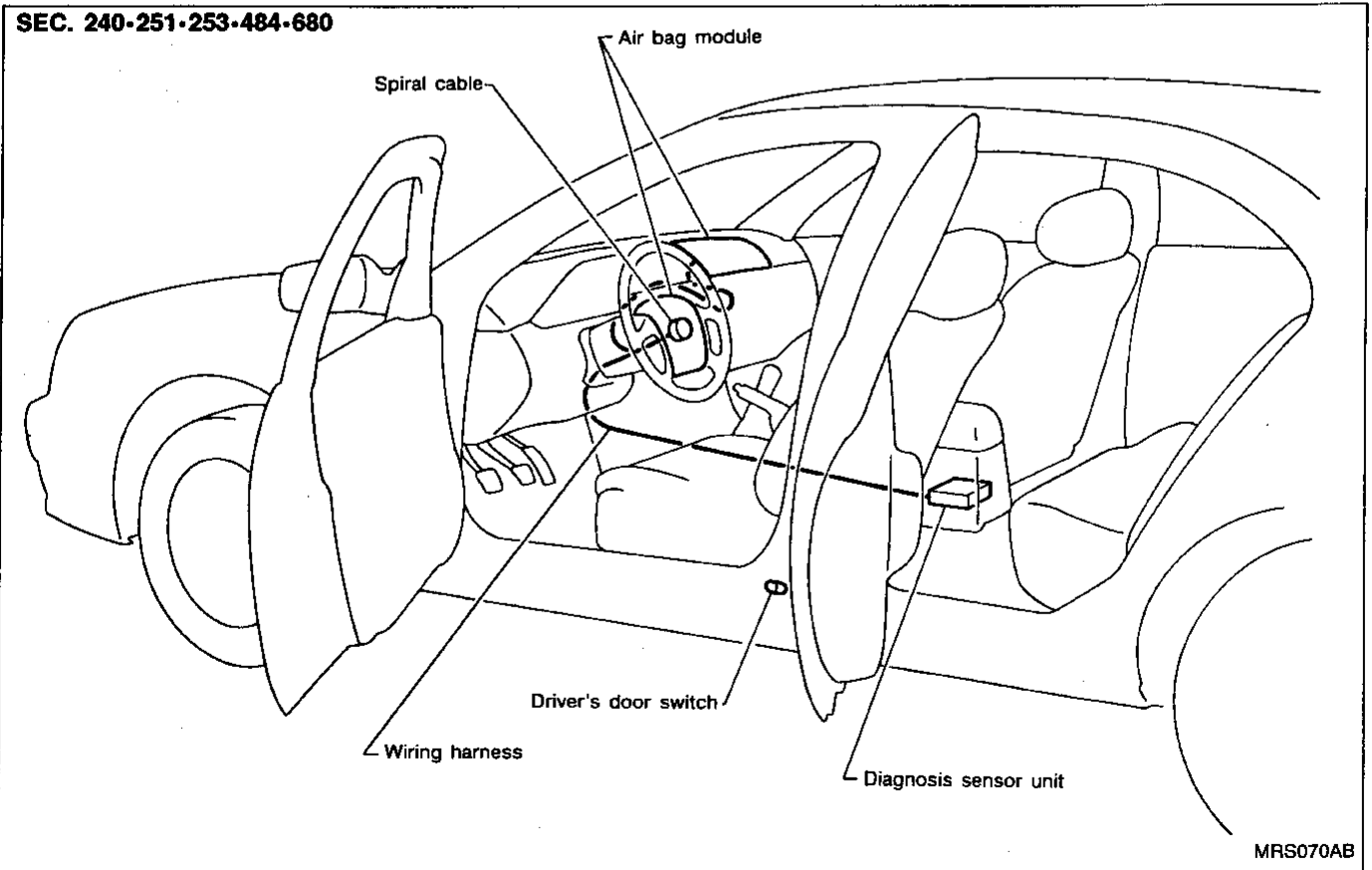

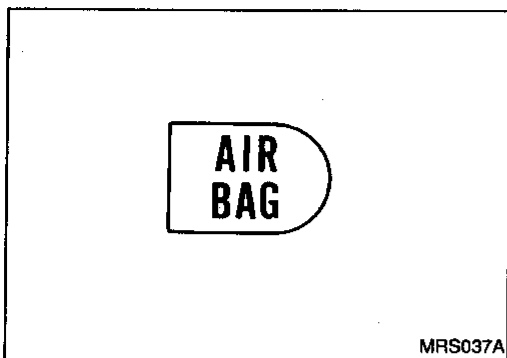

## Maintenance Items

### CAUTION:

**Do not use a circuit tester to check SRS circuit.**

1. Check "AIR BAG" warning lamp operation
  - After turning ignition key to "ON" position, "AIR BAG" warning lamp illuminates. The "AIR BAG" warning lamp will turn off after about 7 seconds if no malfunction is detected.
  - If any of the following air bag warning lamp conditions occur, immediately check the air bag system. Refer to RS-22 for details.
  - The warning lamp does not illuminate when the ignition switch is turned "ON".
  - The warning lamp does not turn off about 7 seconds after the ignition switch is turned "ON".
  - The warning lamp blinks about 7 seconds after the ignition switch is turned "ON".
  
2. Visually check SRS components
  - (1) Diagnosis sensor unit
    - Check diagnosis sensor unit and bracket for dents, cracks or deformities.
    - Check connectors for damage, and terminals for deformities.
  
  - (2) Air bag module and steering wheel
    - Remove air bag module from steering wheel or instrument panel. Check harness cover and connectors for damage, terminals for deformities, and harness for binding.
    - Install driver side air bag module to steering wheel to check fit or alignment with the wheel.
    - Check steering wheel for excessive free play.
    - Install passenger side air bag module to instrument panel to check fit or alignment with the instrument panel.
  
  - (3) Spiral cable
    - Check spiral cable for dents, cracks, or deformities.
    - Check connectors and protective tape for damage.
    - Check steering wheel for noise, binding or heavy operation.
  
  - (4) Main harness and air bag harness
    - Check connectors for poor connections, damage, and terminals for deformities.
    - Check harnesses for binding, chafing or cut.

### CAUTION:

**Replace previously used special bolts and ground bolt with new ones.**

GI  
MA  
EM  
LC  
EC  
FE  
CL  
MT  
AT  
FA  
RA  
BR  
ST  
RS  
BT  
HA  
EL  
IDX

# SUPPLEMENTAL RESTRAINT SYSTEM (SRS)

## Removal and Installation — Diagnosis Sensor Unit

### CAUTION:

- Before servicing SRS, turn the ignition switch off, disconnect both battery cables and wait for at least 3 minutes.
- The special bolts are coated with bonding agent while the other bolt is for ground. Do not use old bolts after removal; replace with new ones.
- Check diagnosis sensor unit for proper installation.
- Check diagnosis sensor unit to ensure they are free of deformities, dents, cracks or rust. If they show any visible signs of damage, replace them with new ones.
- Check diagnosis sensor unit brackets to ensure they are free of deformities or rust.
- Replace diagnosis sensor unit if it has been dropped or sustained an impact.
- After replacement of diagnosis sensor unit, perform self-diagnosis for SRS. Refer to "Self-diagnosis" for details (RS-22).

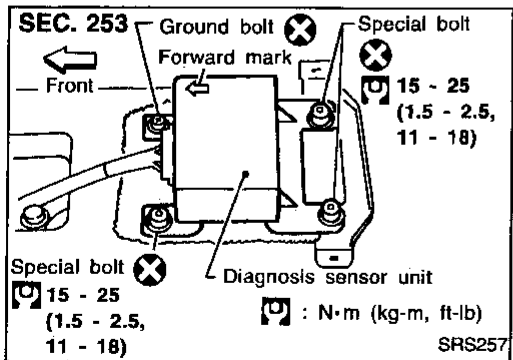

### REMOVAL OF DIAGNOSIS SENSOR UNIT

1. Disconnect driver and passenger air bag module connectors.
2. Remove console box. Refer to "INSTRUMENT PANEL" in BT section.
3. Disconnect diagnosis sensor unit connector.
4. Remove bolt and also remove special bolts using the TAMPER RESISTANT TORX (Size T50), from diagnosis sensor unit. Then remove the diagnosis sensor unit.

### NOTE:

- To install, reverse the removal procedure sequence.

## Removal and Installation — Air Bag Module and Spiral Cable

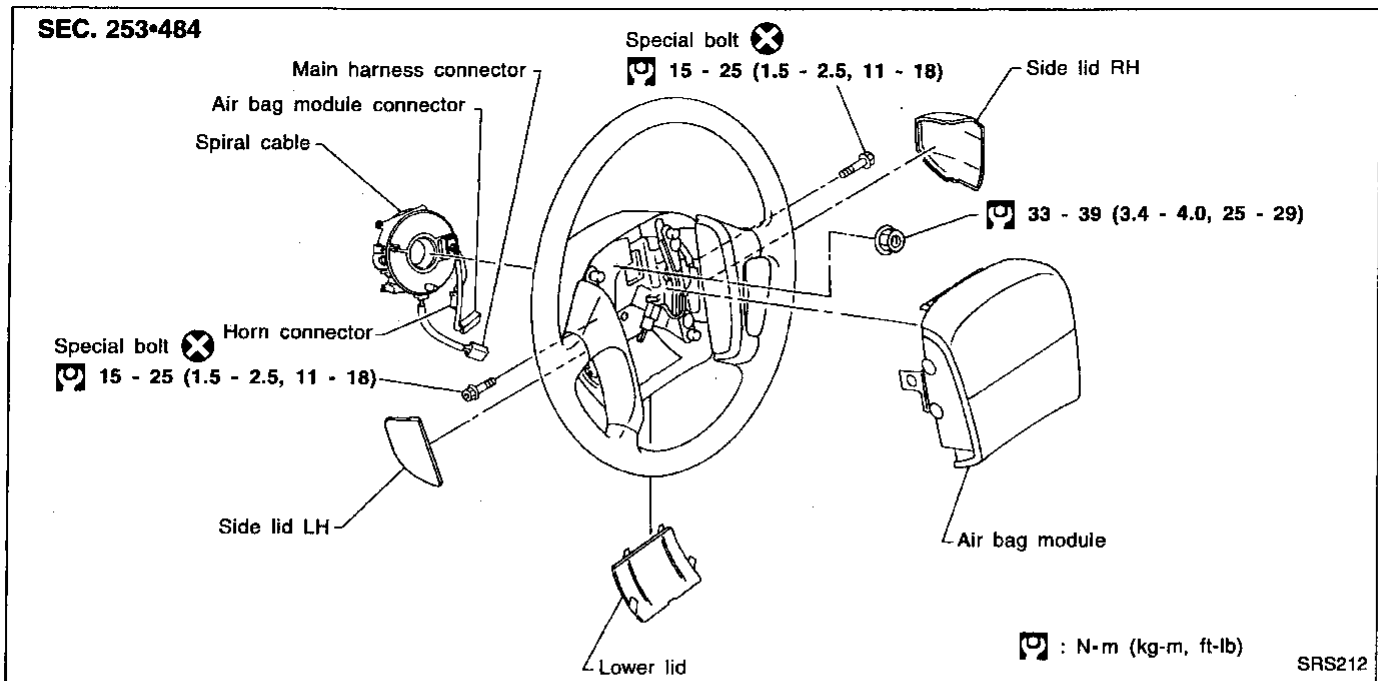



## SUPPLEMENTAL RESTRAINT SYSTEM (SRS)

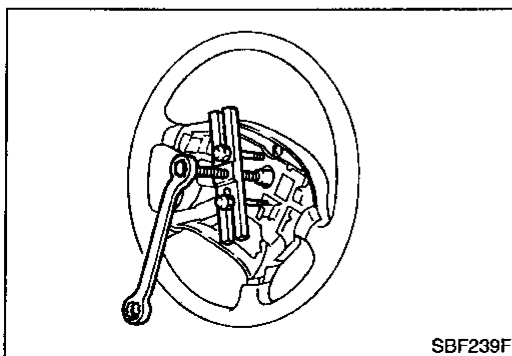
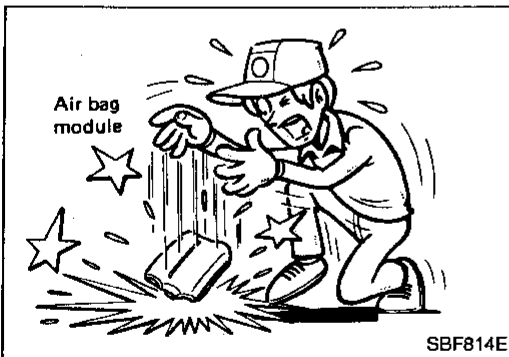
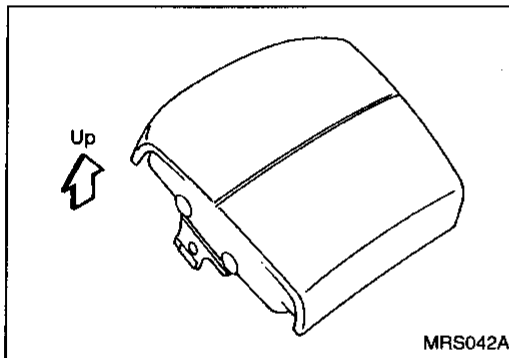
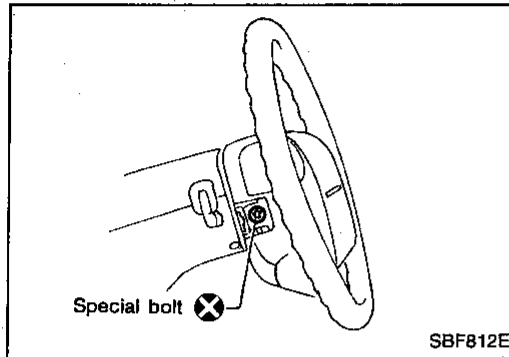
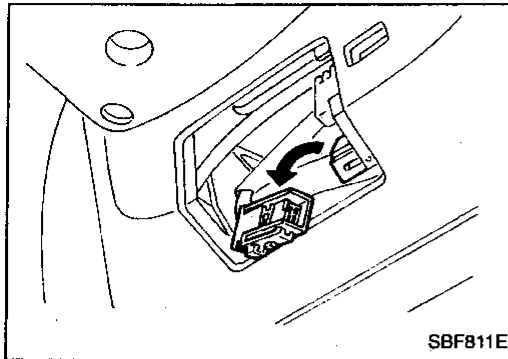

### Removal — Air Bag Module and Spiral Cable

#### CAUTION:

- Before servicing SRS, turn the ignition switch off, disconnect both battery cables and wait for at least 3 minutes.
- Always work from the side of air bag module.

1. Remove lower lid from steering wheel, and disconnect air bag module connector.
2. Remove side lids. Using the TAMPER RESISTANT TORX (Size T50), remove left and right special bolts. Air bag module can then be removed.

#### CAUTION:

- Always place air bag module with pad side facing upward.
- Do not attempt to disassemble air bag module.
- The special bolts are coated with bonding agent. Do not use old bolts after removal; replace with new ones.
- Do not insert any foreign objects (screwdriver, etc.) into air bag module connector.

- Replace air bag module if it has been dropped or sustained an impact.
- Do not expose the air bag module to temperatures exceeding 90°C (194°F).
- Do not allow oil, grease or water to come in contact with the air bag module.

3. Set steering wheel in the neutral position.
4. Disconnect horn connector and remove nuts.
5. Using steering wheel puller, remove steering wheel. Be careful not to over-tighten puller bolt on steering wheel.

#### CAUTION:

- Do not tap or bump the steering wheel.
6. Remove steering column cover.
  7. Disconnect connectors and remove the four screws. The spiral cable can then be removed.

#### CAUTION:

- Do not attempt to disassemble spiral cable.
- Do not apply lubricant to the spiral cable.

## SUPPLEMENTAL RESTRAINT SYSTEM (SRS)

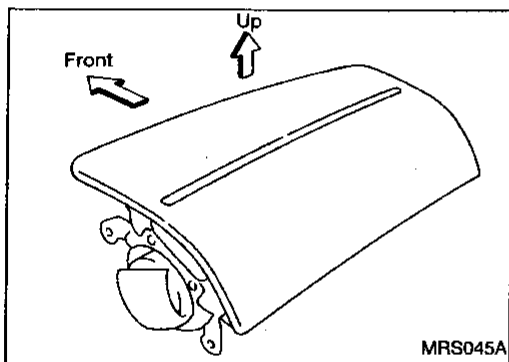
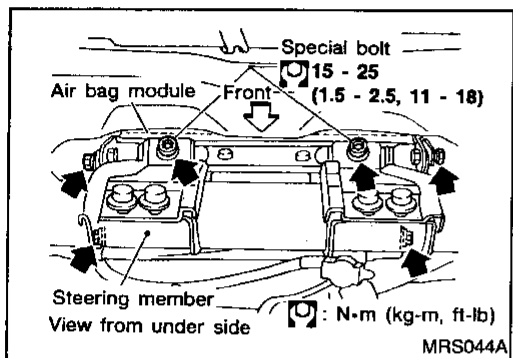
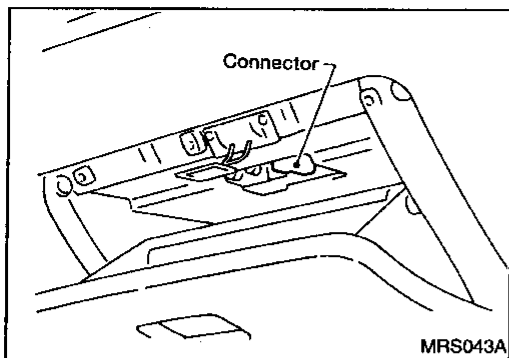

### Removal — Front Passenger Air Bag Module

#### CAUTION:

- Before servicing SRS, turn the ignition switch off, disconnect both battery cables and wait for at least 3 minutes.
  - Always work from the side of or under air bag module.
1. Open the glove box lid.
  2. Disconnect air bag module connector from body harness air bag connector.
  3. Remove glove box assembly. Refer to "INSTRUMENT PANEL" in BT section for details.
  4. Remove the bolts and special bolts using the TAMPER RESISTANT TORX (Size T50) from front passenger air bag module. Take out the air bag module from the instrument panel.
- The air bag module is heavy and should be supported using both hands during removal.

#### CAUTION:

- Always place air bag module with pad side facing upward.
  - Do not attempt to disassemble air bag module.
  - The special bolts are coated with bonding agent. Do not use old bolts after removal; replace with new coated bolts.
  - Do not insert any foreign objects (screwdriver, etc.) into air bag module connector.
- 
- Replace air bag module if it has been dropped or sustained an impact.
  - Do not expose the air bag module to temperatures exceeding 90°C (194°F).
  - Do not allow oil, grease or water to come in contact with the air bag module.
  - After air bag inflates, the front instrument panel assembly should be replaced if damaged.

## Installation — Air Bag Module and Spiral Cable

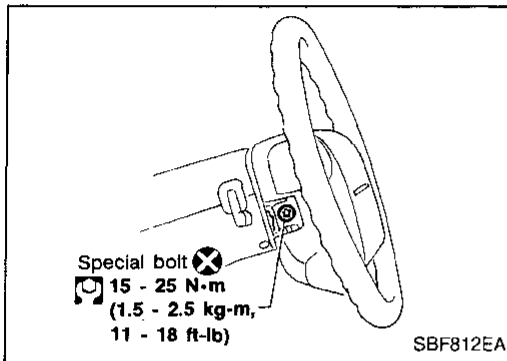
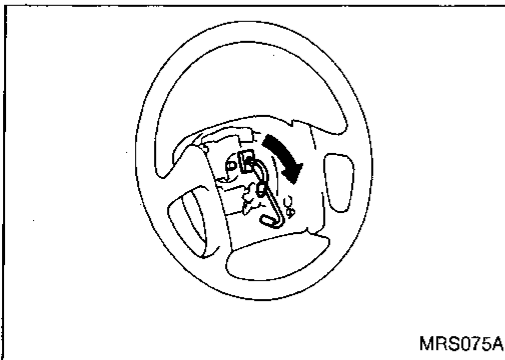
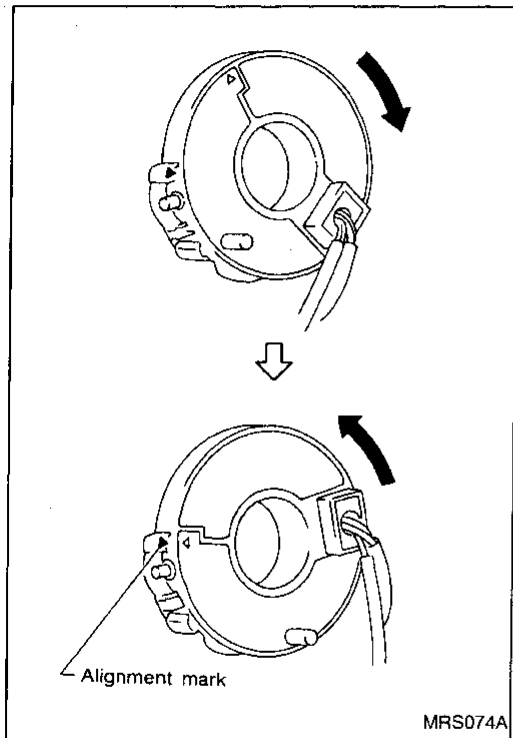

1. Set the front wheels in the straight-ahead position.
2. Make sure that the spiral cable is in the neutral position. The neutral position is detected by turning left about 3.5 revolutions from the right end position. Align the two marks (X).

### CAUTION:

- The spiral cable may snap due to steering operation if the cable is installed in an improper position.
- Also, with the steering linkage disconnected, the cable may snap by turning the steering wheel beyond the limited number of turns.

(The spiral cable can be turned up to about 3.5 turns from the neutral position to both the right and left. The number of turns depends on the spiral cable type. Always confirm the number indicated on the caution label attached to the spiral cable before starting work.)

3. Connect main harness connector and tighten with screws. Install steering column cover.

4. Install steering wheel setting spiral cable pin guides, and pull spiral cable through.
5. Connect horn connector and engage spiral cable with pawls in steering wheel.
6. Tighten nut.

: 33 - 39 N·m (3.4 - 4.0 kg·m, 25 - 29 ft·lb)

7. Position air bag module and tighten with new special bolts.
8. Connect air bag module connector.
9. Install all lids.

10. Conduct self-diagnosis to ensure entire SRS operates properly. (Use CONSULT or warning lamp check.) Before performing self-diagnosis, connect both battery cables.
11. Turn steering wheel to the left end and then to the right end fully to make sure that spiral cable is set in the neutral position.

If air bag warning lamp blinks or stays ON (at the user mode), it shows the spiral cable may be snapped due to its improper position. Perform self-diagnosis again (use CONSULT or warning lamp). If a malfunction is detected, replace the spiral cable with a new one.

12. Perform self-diagnosis again to check that no malfunction is detected.

## SUPPLEMENTAL RESTRAINT SYSTEM (SRS)

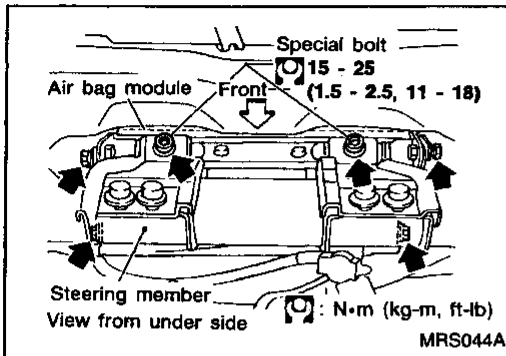

### Installation — Front Passenger Air Bag Module

1. Install front passenger air bag module on steering member.
- Ensure harness is not caught between rear of air bag module and steering member.
2. Install glove box assembly. (Glove box lid is open.)

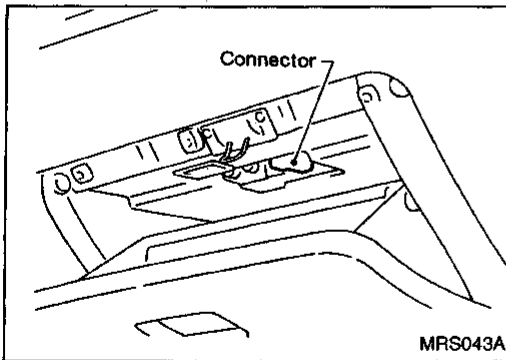

3. Connect air bag module connector to body harness connector.
4. Close the glove box lid.
5. Connect both battery cables.
6. Conduct self-diagnosis to ensure entire SRS operates properly. (Use CONSULT or warning lamp check.)

## Disposal of Air Bag Module

- Before disposing of air bag modules or vehicles equipped with such a system, deploy the system. If such a system has already been deployed due to an accident, dispose of as indicated in "DISPOSING OF AIR BAG MODULE" (RS-16).
- When deploying the air bag module, always use the Special Service Tool; Deployment tool KV99106400 (Kent-Moore No. J38381).
- When deploying the air bag module stand at least 5 m (16 ft) away from the deployment component.
- When deploying air bag module, a fairly loud noise is made, followed by smoke being released. The smoke is not poisonous, however, be careful not to inhale smoke since it irritates throat and can cause choking.
- Always activate one air bag module at a time.
- Due to heat, leave air bag module unattended for more than 30 minutes after deployment.
- Be sure to wear gloves when handling a deployed air bag module.
- Never apply water to a deployed air bag module.
- Wash your hands clean after finishing work.
- Place the vehicle outdoors with an open space of at least 6 m (20 ft) on all sides when deploying the air bag module while mounted in vehicle.
- Use a voltmeter to make sure the vehicle battery is fully charged.
- Do not dispose of the air bag module un-deployed.

GI

MA

EM

LC

EC

FE

CL

MT

AT

FA

RA

BR

ST

RS

BT

HA

EL

IDX

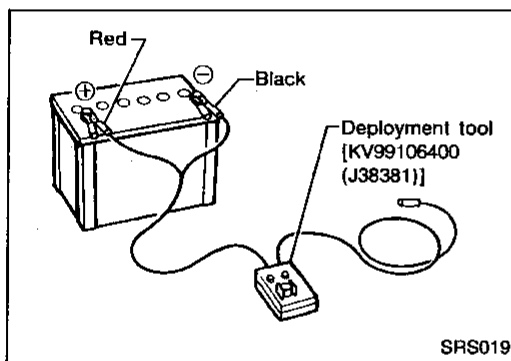

## CHECKING DEPLOYMENT TOOL

### Connecting to battery

#### CAUTION:

The battery must show voltage of 9.6V or more.

Remove the battery from the vehicle and place it on dry wood blocks approximately 5 m (16 ft) away from the vehicle.

- Wait 10 to 12 minutes after the vehicle battery is disconnected before proceeding.
- Connect red clip of deployment tool to battery positive terminal and black clip to negative terminal.

Make sure the polarity is correct. The right side lamp in the tool, marked "deployment tool power", should glow with a green light. If the right side lamp glows red, reverse the connections to the battery.

# SUPPLEMENTAL RESTRAINT SYSTEM (SRS)

## Disposal of Air Bag Module (Cont'd)

### Deployment tool check

Press the deployment tool switch to the "ON" position. The left side lamp in the tool, marked "air bag connector voltage" should illuminate. If it does not illuminate, replace the tool.

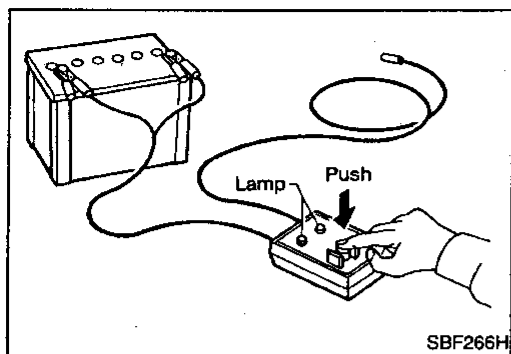

### Air bag deployment tool lamp illumination chart (Battery connected)

Switch operation	Left side lamp, green* "AIR BAG CONNECTOR VOLTAGE"	Right side lamp, green* "DEPLOYMENT TOOL POWER"
OFF	OFF	ON
ON	ON	ON

\*: If this lamp glows red, the tool is connected to the battery incorrectly. Reverse the connections and make sure the lamp glows green.

## DEPLOYMENT PROCEDURES FOR AIR BAG MODULE (OUTSIDE OF VEHICLE)

Unless the vehicle is being scrapped, deploying the air bag in the vehicle is not recommended. This may cause damage to the vehicle interior.

Anchor air bag module in a vise secured to a firm foundation during deployment.

### Deployment of driver's air bag module (outside of vehicle)

1. Prepare two sets of nuts and bolts (see figure at left). These bolts are required to secure driver's air bag module to the vise.
2. Install one set of nuts and bolts to each side of the air bag module.

#### CAUTION:

**Make sure to install a bolt and nut on each side.**

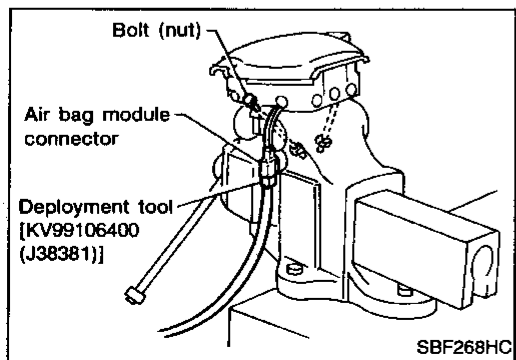
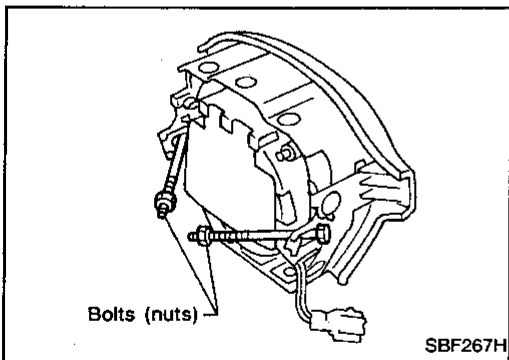
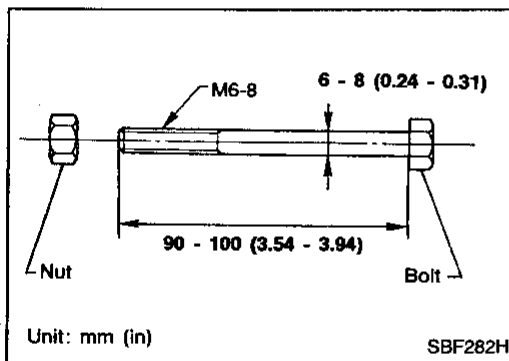

3. Firmly place two nuts (secured to air bag module) in the vise.

#### CAUTION:

**Ensure these two nuts are equally placed in the vise. Never finish the installation with just one nut.**

4. Connect deployment tool [SST: KV99106400 (J38381)] to air bag module connector.

## SUPPLEMENTAL RESTRAINT SYSTEM (SRS)

### Disposal of Air Bag Module (Cont'd)

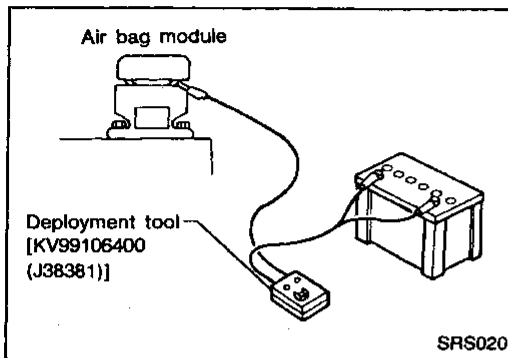

5. Connect red clip of deployment tool to battery positive terminal and black clip to negative terminal.
6. The lamp on the right side of the tool, marked "deployment tool power", should glow green, not red.
7. Press the button on the deployment tool. The left side lamp on the tool, marked "air bag connector voltage", will illuminate and the air bag module will deploy.

#### CAUTION:

When deploying the air bag module, stand at least 5 m (16 ft) away from the air bag module.

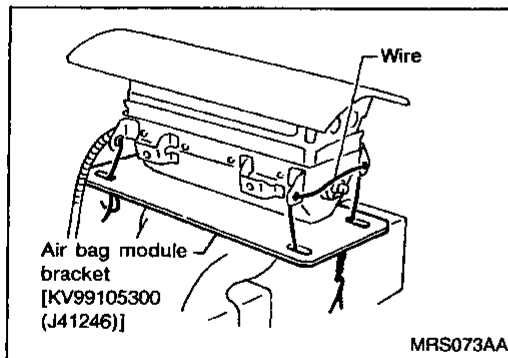

### Deployment of passenger air bag module (outside of vehicle)

1. Using wire, secure air bag module to air bag module bracket [SST: KV99105300 (J41246)] at two places.

#### CAUTION:

Use wire of at least 1 mm (0.04 in) in diameter.

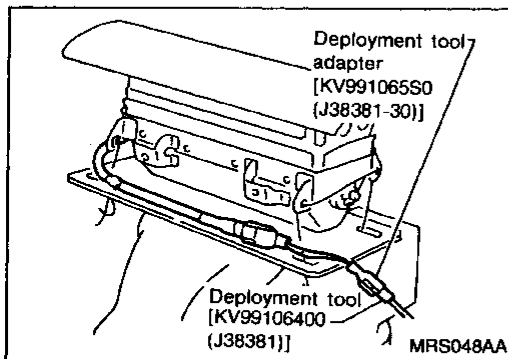

2. Firmly anchor air bag module bracket in a vise.
3. Connect deployment tool adapter [SST: KV991065S0 (J38381-30)] to deployment tool [SST: KV99106400 (J38381)] connector and connector on either side of air bag module.
4. Connect red clip of deployment tool to battery positive terminal and black clip to negative terminal.
5. The lamp on the right side of the tool, marked "deployment tool power", should glow green, not red.
6. Press the button on the deployment tool. The left side lamp on the tool, marked "air bag connector voltage", will illuminate and the air bag module will deploy.

#### CAUTION:

When deploying the air bag module, stand at least 5 m (16 ft) away from the air bag module.

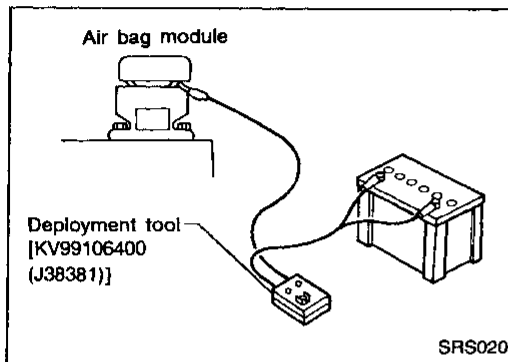

## SUPPLEMENTAL RESTRAINT SYSTEM (SRS)

### Disposal of Air Bag Module (Cont'd)

#### DEPLOYMENT OF AIR BAG MODULE WHILE MOUNTED IN VEHICLE

When disposing of a vehicle, deploy air bag module while it is mounted in vehicle.

#### CAUTION:

**When deploying air bag module, ensure vehicle is empty.**

1. Disconnect both battery cables and wait 3 minutes.
2. Disconnect air bag module connector.
3. Connect deployment tool connector [SST: KV99106400 (J38381)] to air bag module.

For passenger air bag module, attach deployment tool adapter [SST: KV991065S0 (J38381-30)] to the tool connector.

4. Connect red clip of deployment tool to battery positive terminal and black clip to negative terminal.
5. The lamp on the right side of the tool, marked "deployment tool power", should glow green, not red.
6. Press the button on the deployment tool. The left side lamp on the tool, marked "air bag connector voltage", will illuminate and the air bag module will deploy.

#### CAUTION:

**Activate only one air bag module at a time.**

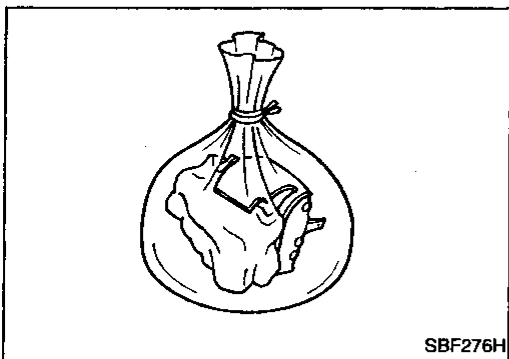
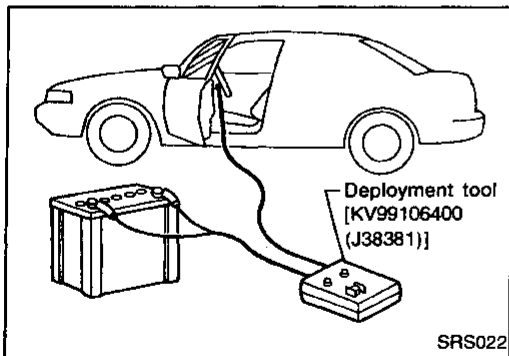
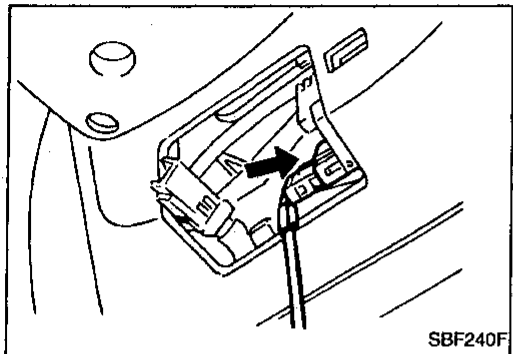

#### DISPOSING OF AIR BAG MODULE

Deployed air bag module is very hot. Before disposing of air bag modules, wait at least 30 minutes. Seal them in a plastic bag before disposal.

#### CAUTION:

- Never apply water to a deployed air bag module.
- Be sure to wear gloves when handling a deployed air bag module.
- No poisonous gas is produced upon air bag module deployment. However, be careful not to inhale gas since it irritates throat and can cause choking.
- Do not attempt to disassemble air bag module.
- Air bag module can not be re-used.
- Wash your hands clean after finishing work.



## How to Perform Trouble Diagnoses for Quick and Accurate Repair

A good understanding of the malfunction conditions can make troubleshooting faster and more accurate. In general, each customer feels differently about a problem. It is important to fully understand the symptoms or conditions for a customer complaint.

### INFORMATION FROM CUSTOMER

- WHAT ..... Vehicle model
- WHEN ..... Date, Frequencies
- WHERE ..... Road conditions
- HOW ..... Operating conditions, Symptoms

### PRELIMINARY CHECK

Check that the following parts are in good order.

- Battery [Refer to MA section (“GENERAL MAINTENANCE”).]
- Fuse [Refer to EL section (“Fuse”, “POWER SUPPLY ROUTING”).]
- System component-to-harness connections

### DIAGNOSIS FUNCTION

The SRS self-diagnosis results can be read by using “AIR BAG” warning lamp and/or CONSULT. The reading of these results is accomplished using one of two modes — “User mode” and “Diagnosis mode”.

The User mode is exclusively prepared for the customer (driver). This mode warns the driver of a system malfunction through the operation of the “AIR BAG” warning lamp.

The Diagnosis mode allows the technician to locate and inspect the malfunctioning part.

The mode applications for the “AIR BAG” warning lamp and CONSULT are as follows:

	User mode	Diagnosis mode	Display type
“AIR BAG” warning lamp	X	X	ON-OFF operation
CONSULT	—	X	Monitoring

### DIAGNOSIS MODE FOR CONSULT

- SELF-DIAG [CURRENT]  
A current Self-diagnosis result (also indicated by the warning lamp flashes in the Diagnosis mode) is displayed on the CONSULT screen in real time. This refers to a malfunctioning part requiring repairs.
- SELF-DIAG [PAST]  
Diagnosis results previously stored in the memory (also indicated by the warning lamp flashes in the Diagnosis mode) are displayed on the CONSULT screen. The stored results are not erased until memory erasing is executed.
- TROUBLE DIAG RECORD  
With TROUBLE DIAG RECORD, diagnosis results previously erased by a reset operation can be displayed on the CONSULT screen.

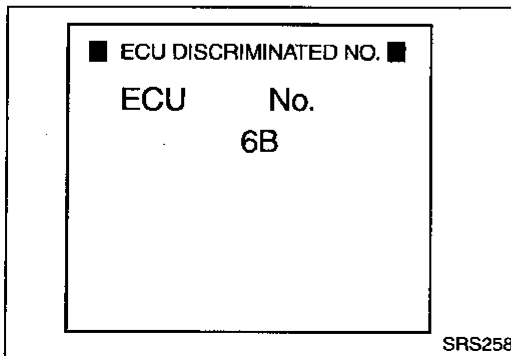

- ECU DISCRIMINATED NO.  
The diagnosis sensor unit for each vehicle model is assigned with its own, individual classification number. This number will be displayed on the CONSULT screen, as shown at left. When replacing the diagnosis sensor unit, refer to the part number for the compatibility. After installation, replacement with a correct unit can be checked by confirming this classification number on the CONSULT screen.

**For INFINITI I30, the diagnosis sensor unit classification number assigned is 6B.**

# TROUBLE DIAGNOSES — Supplemental Restraint System (SRS)

## How to Perform Trouble Diagnoses for Quick and Accurate Repair (Cont'd)

### CAUTION:

- Do not use a circuit tester to check SRS harness connectors unless instructed to in this Service Manual. The connectors have yellow outer insulation for easy identification.
- Do not attempt to repair, splice or modify the SRS wiring harness. If the harness is damaged, replace it with a new one.
- Keep ground portion clean.

### WORK FLOW

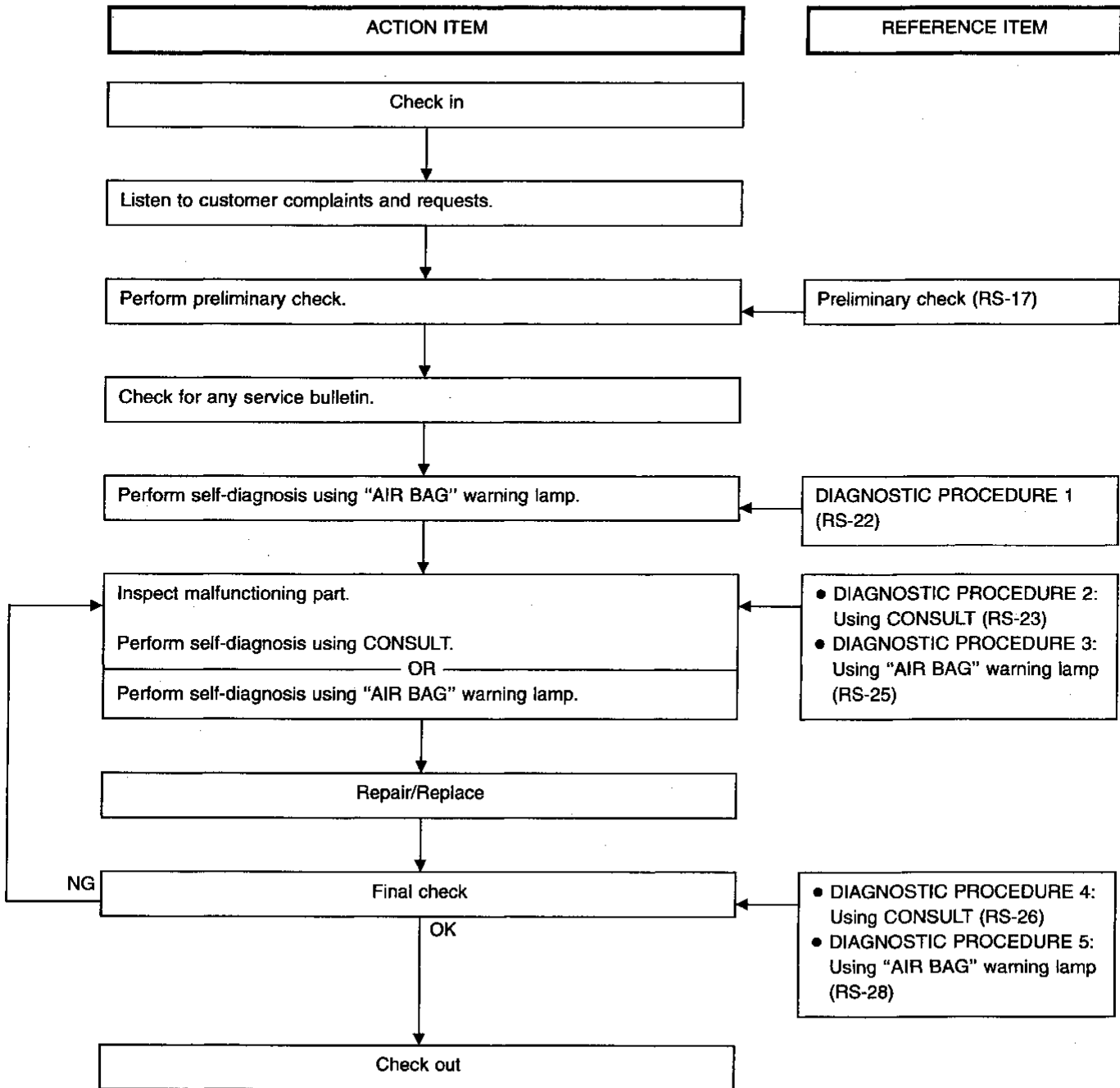

Schematic

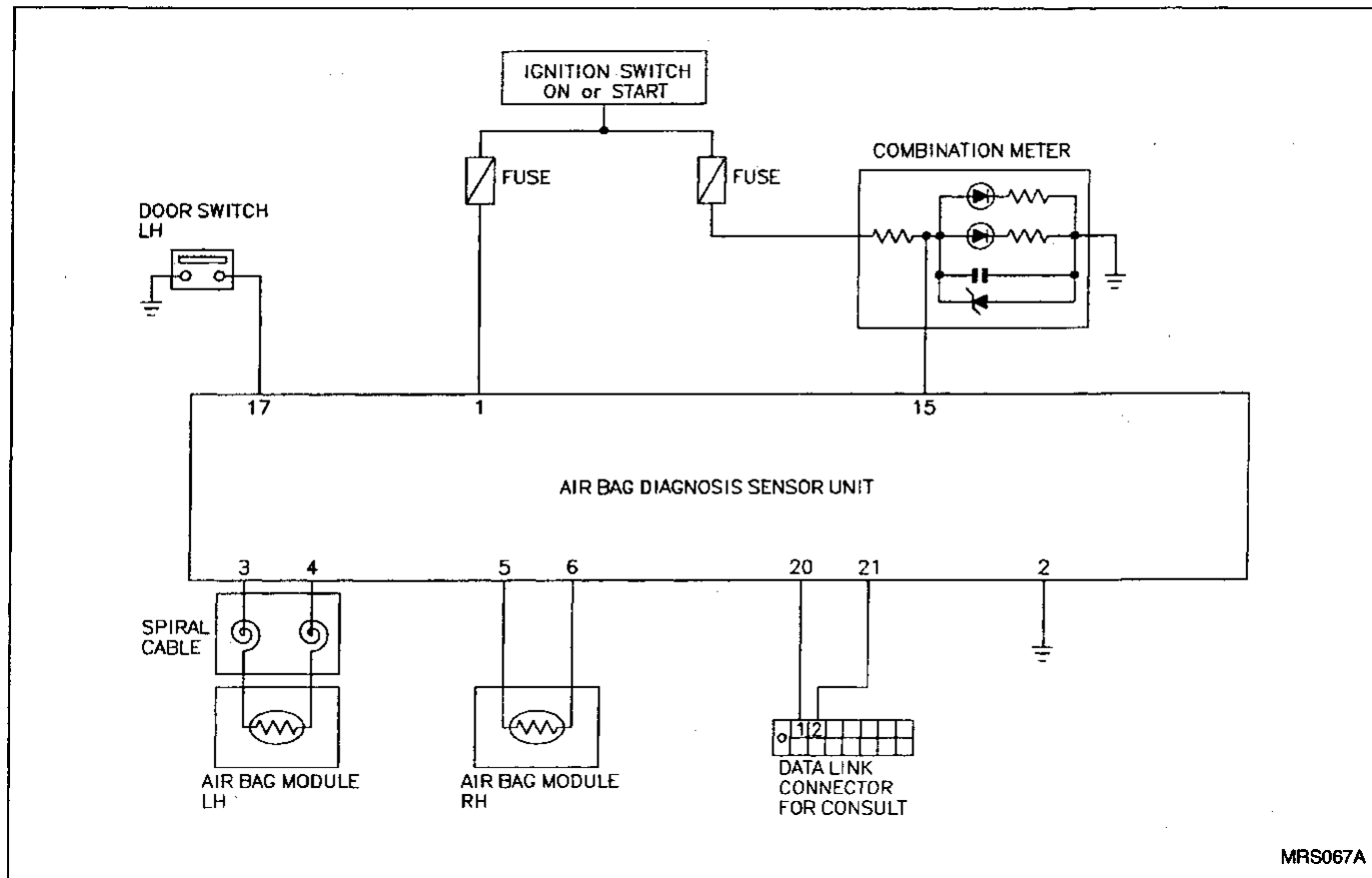

GI  
MA  
EM  
LC  
EC  
FE  
CL  
MT  
AT  
FA  
RA  
BR  
ST  
RS  
BT  
HA  
EL  
IDX

Wiring Diagram — SRS —

RS-SRS-01

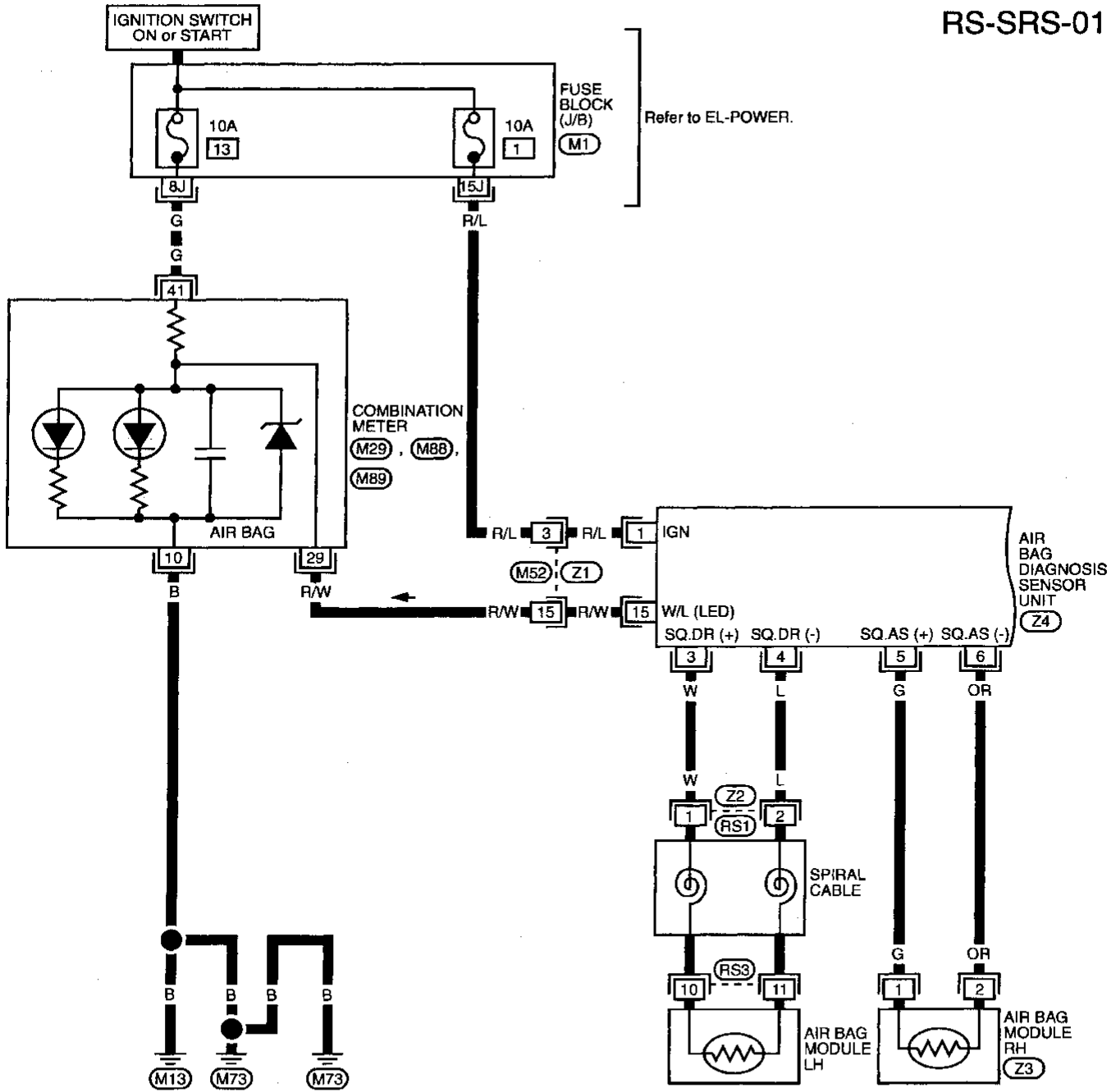

Refer to last page (Foldout page).

(M1)

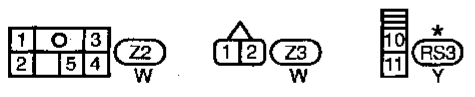
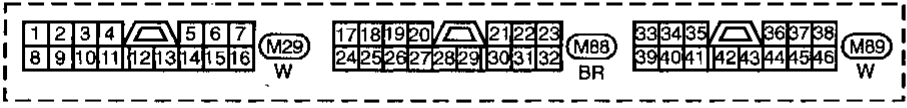

\* : This connector is not shown in "HARNESS LAYOUT" of EL section.

**TROUBLE DIAGNOSES — Supplemental Restraint System (SRS)**  
**Wiring Diagram — SRS — (Cont'd)**

RS-SRS-02

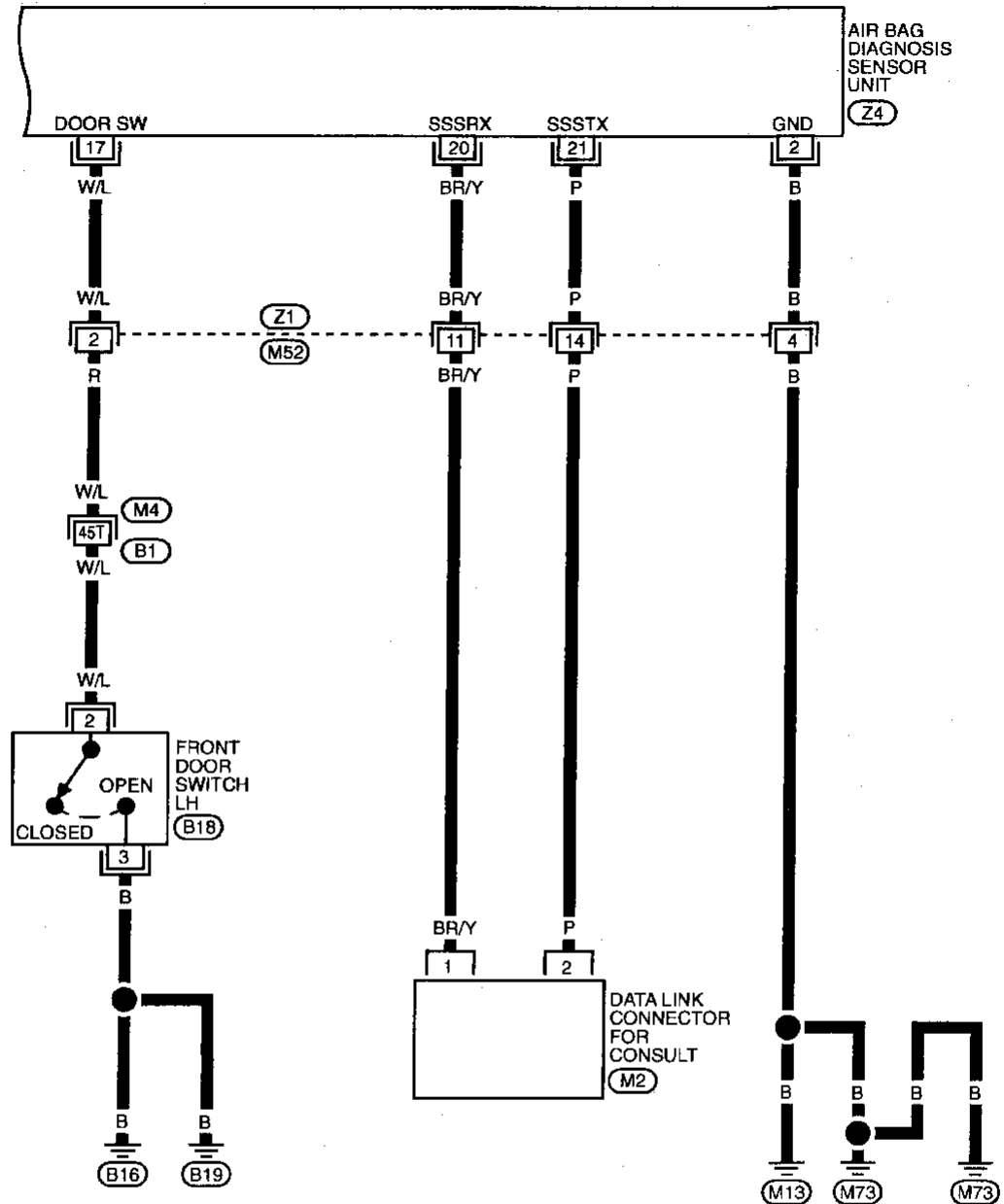

GI  
MA  
EM  
LC  
EC  
FE  
CL  
MT  
AT  
FA  
RA  
BR  
ST  
**RS**  
BT  
NA  
EL  
IDX

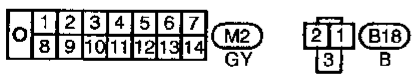
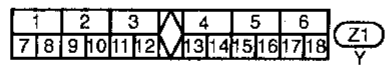
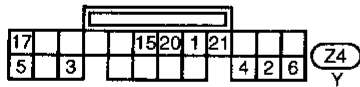

Refer to last page (Foldout page).  
 (M4) (B1)

# TROUBLE DIAGNOSES — Supplemental Restraint System (SRS)

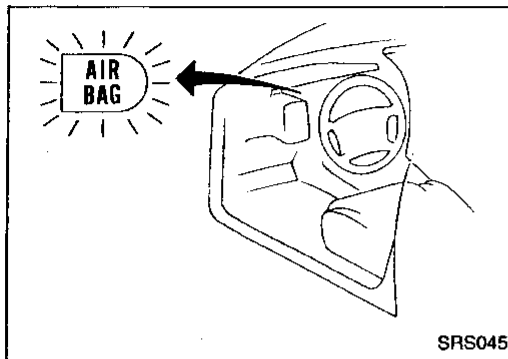

## Self-diagnosis

### DIAGNOSTIC PROCEDURE 1

#### Checking SRS operation by using "AIR BAG" warning lamp — User mode

1. After turning ignition switch from "OFF" to "ON", "AIR BAG" warning lamp operates.
2. Compare "AIR BAG" warning lamp operation to the chart below.

"AIR BAG" warning lamp operation — User mode —	SRS condition	Reference item
<p>MRS095A</p>	No malfunction is detected. No further action is necessary.	—
<p>MRS096A</p>	The system has problem and needs to be repaired as indicated.	Go to DIAGNOSTIC PROCEDURE 2, or 3 (RS-23 or 25).
<p>MRS097A</p>	Air bag is deployed.  Air bag fuse, diagnosis sensor unit or harness is malfunctioning and needs to be repaired.	Go to COLLISION DIAGNOSIS (RS-36).  Go to DIAGNOSTIC PROCEDURE 9 (RS-34).
<p>MRS098A</p>	One of the following has occurred and needs to be repaired. <ul style="list-style-type: none"> <li>● Meter fuse is blown.</li> <li>● "AIR BAG" warning lamp circuit has open or short.</li> <li>● Diagnosis sensor unit is malfunctioning.</li> </ul>	Go to DIAGNOSTIC PROCEDURE 10 (RS-34).

#### NOTE:

If "AIR BAG" warning lamp operates differently from the operations shown above, refer to "AIR BAG" warning lamp operation — Diagnosis mode —, DIAGNOSTIC PROCEDURE 3 (step 4), RS-25.

# TROUBLE DIAGNOSES — Supplemental Restraint System (SRS)

## Self-diagnosis (Cont'd)

### DIAGNOSTIC PROCEDURE 2 (CONSULT) with CONSULT

Inspecting SRS malfunctioning parts by using CONSULT — Diagnosis mode

1. Turn ignition switch "OFF".
2. Connect "CONSULT" to Data link connector.

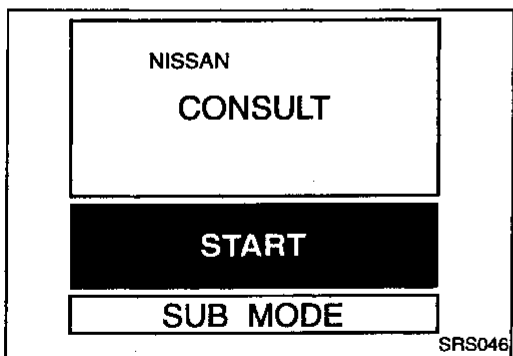
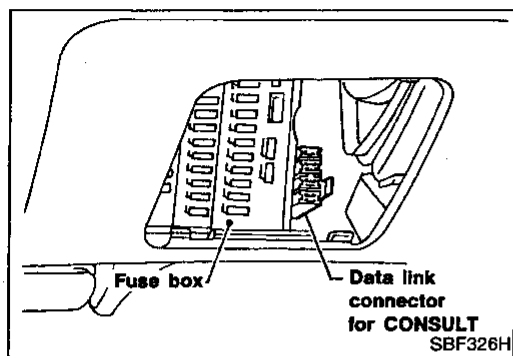

3. Turn ignition switch "ON".
4. Touch "START".

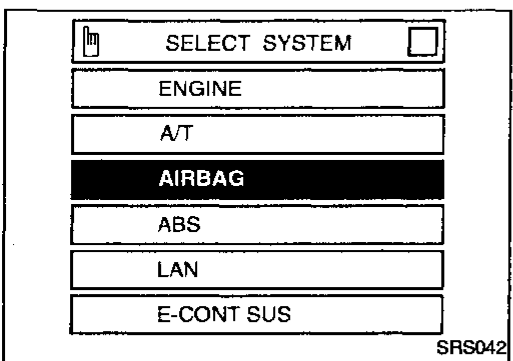

5. Touch "AIRBAG".

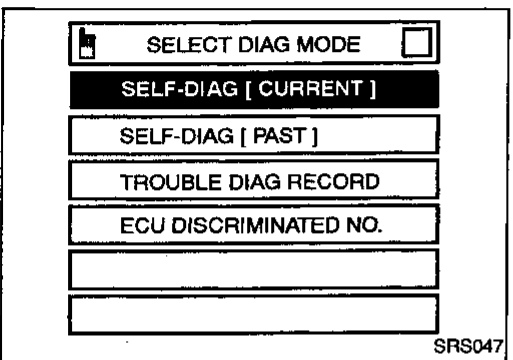

6. Touch "SELF-DIAG [CURRENT]".

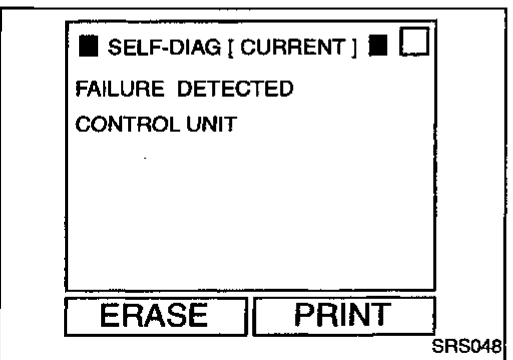

7. Diagnostic codes are displayed on "SELF-DIAG [CURRENT]".

GI  
MA  
EM  
LC  
EC  
FE  
CL  
MT  
AT  
FA  
RA  
BR  
ST  
RS  
BT  
HA  
EL  
IDX

# TROUBLE DIAGNOSES — Supplemental Restraint System (SRS)

## Self-diagnosis (Cont'd)

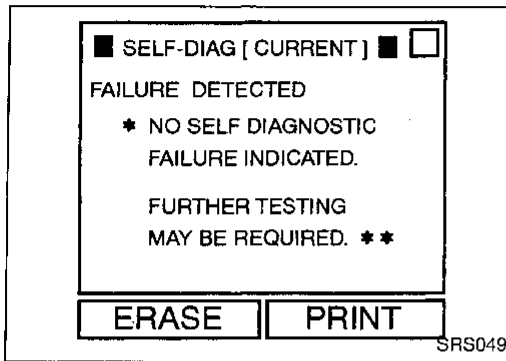

If no self-diagnostic failure is detected on "SELF-DIAG [CURRENT]" even though malfunction is detected in DIAGNOSTIC PROCEDURE 1, go to DIAGNOSTIC PROCEDURE 6, page RS-30.

8. Touch "PRINT".
9. Compare diagnostic codes to the CONSULT DIAGNOSTIC CODE CHART, page RS-24.
10. Touch "BACK" key of CONSULT until SELECT SYSTEM appears, then turn off CONSULT.
11. Turn ignition switch "OFF", then disconnect CONSULT and both battery cables.
12. Repair the system as outlined by the "Repair order" in CONSULT DIAGNOSTIC CODE CHART, that corresponds to the problem code. For replacement procedure of component parts, refer to RS-8.
13. After repairing the system, go to DIAGNOSTIC PROCEDURE 4, page RS-26.

## CONSULT DIAGNOSTIC CODE CHART

Diagnostic item	Explanation	Repair order Recheck SRS at each replacement.
NO SELF DIAGNOSTIC FAILURE INDICATED.	<ul style="list-style-type: none"> <li>● No malfunction is detected.</li> </ul>	<ul style="list-style-type: none"> <li>● Go to DIAGNOSTIC PROCEDURE 6 (RS-30).</li> </ul>
AIRBAG MODULE [OPEN]	<ul style="list-style-type: none"> <li>● Driver's air bag module circuit is open. (including the spiral cable)</li> </ul>	<ol style="list-style-type: none"> <li>1. Visually check the wiring harness connection.</li> <li>2. Replace the harness if it has visible damage.</li> <li>3. Replace driver's air bag module. (Before disposal of it, it must be deployed.)</li> <li>4. Replace the spiral cable.</li> <li>5. Replace the diagnosis sensor unit.</li> </ol>
AIRBAG MODULE [VB-SHORT]	<ul style="list-style-type: none"> <li>● Driver's air bag module circuit is shorted to some power supply circuit. (including the spiral cable)</li> </ul>	
AIRBAG MODULE [GND-SHORT]	<ul style="list-style-type: none"> <li>● Driver's air bag module circuit is shorted to ground. (including the spiral cable)</li> </ul>	
AIRBAG MODULE [SHORT]	<ul style="list-style-type: none"> <li>● Driver's air bag module circuits are shorted to each other.</li> </ul>	
ASSIST A/B MODULE [VB-SHORT]	<ul style="list-style-type: none"> <li>● Front passenger air bag module circuit is shorted to some power supply circuit.</li> </ul>	<ol style="list-style-type: none"> <li>1. Visually check the wiring harness connection.</li> <li>2. Replace the harness if it has visible damage.</li> <li>3. Replace front passenger air bag module. (Before disposal of it, it must be deployed.)</li> <li>4. Replace the diagnosis sensor unit.</li> </ol>
ASSIST A/B MODULE [OPEN]	<ul style="list-style-type: none"> <li>● Front passenger air bag module circuit is open.</li> </ul>	
ASSIST A/B MODULE [GND-SHORT]	<ul style="list-style-type: none"> <li>● Front passenger air bag module circuit is shorted to ground.</li> </ul>	
ASSIST A/B MODULE [SHORT]	<ul style="list-style-type: none"> <li>● Front passenger air bag module circuits are shorted to each other.</li> </ul>	
CONTROL UNIT	<ul style="list-style-type: none"> <li>● Diagnosis sensor unit is out of order.</li> </ul>	<ul style="list-style-type: none"> <li>● Replace the diagnosis sensor unit.</li> </ul>

\* Follow the procedures in numerical order when repairing malfunctioning parts. Confirm whether malfunction is eliminated using the air bag warning lamp (in User mode) or CONSULT each time repair is finished. If malfunction is still observed, proceed to the next step. When malfunction is eliminated, further repair work is not required.



# TROUBLE DIAGNOSES — Supplemental Restraint System (SRS)

## Self-diagnosis (Cont'd)

### DIAGNOSTIC PROCEDURE 3 ( without CONSULT) Inspecting SRS malfunctioning parts by using "AIR BAG" warning lamp — Diagnosis mode

**NOTE:**

SRS will not enter Diagnosis mode if no malfunction is detected.

1. Open driver's door.
2. Turn ignition switch from "OFF" to "ON".
3. Press driver's door switch at least 5 times within 7 seconds after turning ignition switch "ON".  
SRS is now in Diagnosis mode.
4. "AIR BAG" warning lamp operates in diagnosis mode as follows:

**NOTE:**

If SRS does not enter Diagnosis mode even though malfunction is detected in User mode, go to DIAGNOSTIC PROCEDURE 11, page RS-35.

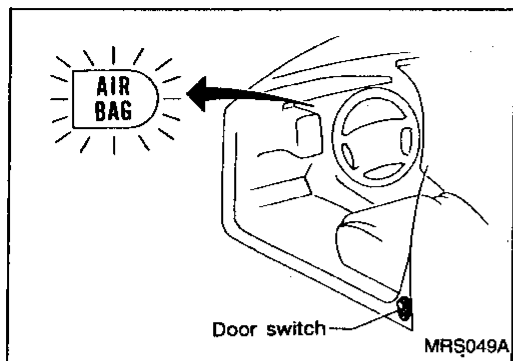

No.	"AIR BAG" warning lamp operation — Diagnosis mode —	SRS condition
1	<p style="text-align: right;">Ⓐ through Ⓑ are repeated.</p> <p style="text-align: center;">MRS100A</p>	<p>Intermittent problem has been detected in the past. Go to DIAGNOSTIC PROCEDURE 7 (RS-31).</p>
2	<p style="text-align: right;">Ⓐ through Ⓓ are repeated.</p> <p><b>NOTE:</b></p> <p>Ⓐ — Interval I            Ⓑ — Start signal (Start signal identifies display modes)            Ⓒ — Interval II            Ⓓ — Indicates malfunctioning part (0.5 sec. ON and 0.5 sec. OFF is counted as one flash.)</p> <p style="text-align: center;">MRS099A</p>	<p>The system has problem and needs to be repaired.</p>

5. Malfunctioning part is indicated by the number of flashes (part Ⓓ). Compare the number of flashes to WARNING LAMP FLASH CODE CHART, page RS-26, and locate malfunctioning part.
6. Turn ignition switch "OFF", and disconnect both battery cables.
7. Repair the system as outlined by the "Repair order" in WARNING LAMP FLASH CODE CHART that corresponds to the flash code. For replacement procedure of component parts, refer to RS-8.
8. After repairing the system, go to DIAGNOSTIC PROCEDURE 5, page RS-28.

# TROUBLE DIAGNOSES — Supplemental Restraint System (SRS)

## Self-diagnosis (Cont'd)

### WARNING LAMP FLASH CODE CHART

Warning lamp	Flash code ④ (# of flashes)	Explanation	Repair order Recheck SRS at each replacement.
"AIR BAG" warning lamp	0	No malfunction is detected.	Go to DIAGNOSTIC PROCEDURE 7 (RS-31).
	2	The driver's air bag module circuit is out of order.	1. Visually check the wiring harness connections. 2. Replace the spiral cable. 3. Replace the driver's air bag module. (Before disposing of it, it must be deployed.) 4. Replace the diagnosis sensor unit. 5. Replace the air bag harness.
	7	The diagnosis sensor unit is out of order.	1. Visually check the wiring harness connections. 2. Replace the diagnosis sensor unit.
	8	The front passenger air bag module circuit is out of order.	1. Visually check the wiring harness connections. 2. Replace the front passenger air bag module. (Before disposing of it, it must be deployed.) 3. Replace the diagnosis sensor unit. 4. Replace the air bag harness.

\* Follow the procedures in numerical order when repairing malfunctioning parts. Confirm whether malfunction is eliminated using the air bag warning lamp (in User mode) or CONSULT each time repair is finished. If malfunction is still observed, proceed to the next step. When malfunction is eliminated, further repair work is not required.

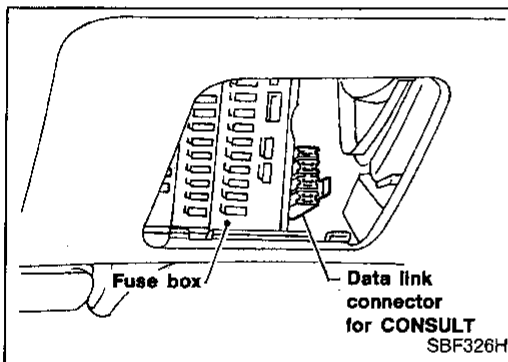

### DIAGNOSTIC PROCEDURE 4 (CONSULT with CONSULT)

#### Final checking after repairing SRS by using CONSULT — Diagnosis mode

1. After repairing SRS, connect both battery cables.
2. Connect CONSULT to Data link connector.
3. Turn ignition switch from "OFF" to "ON".

4. Touch "START".

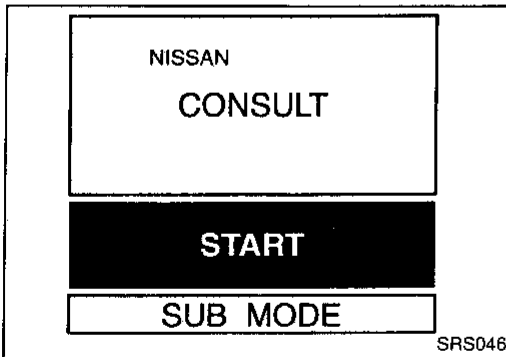

5. Touch "AIRBAG".

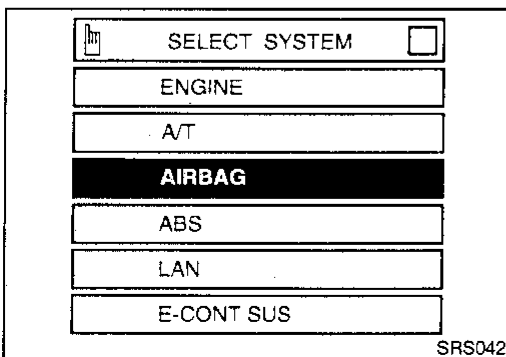

# TROUBLE DIAGNOSES — Supplemental Restraint System (SRS)

## Self-diagnosis (Cont'd)

SRS047

6. Touch "SELF-DIAG [CURRENT]".

SRS049

7. If no malfunction is detected on "SELF-DIAG [CURRENT]", repair of SRS is completed. Touch "ERASE".

**NOTE:**

Touch "ERASE" to erase problem (Trouble code) retained in memory. Otherwise, diagnosis sensor unit still senses problem in memory when step 13 (Air bag warning lamp operation check) is performed. The result is confusing a new with an old problem.

SRS048

If any problem code was displayed on "SELF-DIAG [CURRENT]", the malfunctioning part is not repaired completely or another malfunctioning part is detected. Go to DIAGNOSTIC PROCEDURE 2, page RS-23, and repair malfunctioning part completely.

8. Touch "BACK" key of CONSULT.

SRS050

9. Touch "SELF-DIAG [PAST]".

SRS062

10. Check that no self-diagnostic failure is detected on "SELF-DIAG [PAST]".

GI

MA

EM

LC

EC

FE

CL

MT

AT

FA

RA

BR

ST

RS

BT

HA

EL

IDX

# TROUBLE DIAGNOSES — Supplemental Restraint System (SRS)

## Self-diagnosis (Cont'd)

11. Touch "BACK" key of CONSULT until SELECT SYSTEM appears, turn off CONSULT, then disconnect CONSULT.
12. Turn ignition switch "OFF".
13. Go to DIAGNOSTIC PROCEDURE 1, page RS-22 to check SRS operation by using "AIR BAG" warning lamp with User mode.

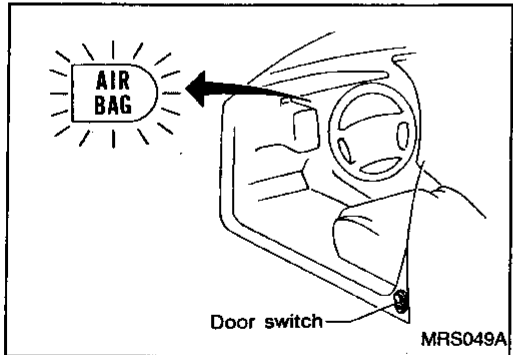

## DIAGNOSTIC PROCEDURE 5 (ⓧ without CONSULT)

Final checking after repairing SRS by using "AIR BAG" warning lamp — Diagnosis mode and User mode

1. After repairing SRS connect both battery cables.
2. Open driver's door.
3. Turn ignition switch from "OFF" to "ON".
4. "AIR BAG" warning lamp operates in diagnostic mode as follows:

No.	"AIR BAG" warning lamp operation — Diagnosis mode —	SRS condition
1	<p style="text-align: right;">① through ② are repeated.</p> <p style="text-align: right;">MRS100A</p>	<p>No malfunction is detected or repair is completed. No further action is necessary.</p>
2	<p style="text-align: right;">③ through ④ are repeated.</p> <p style="text-align: right;">NOTE:            ① — Interval I            ② — Start signal (Start signal identifies display modes)            ③ — Interval II            ④ — Indicates malfunctioning part (0.5 sec. ON and 0.5 sec. OFF is counted as one flash.)</p> <p style="text-align: right;">MRS099A</p>	<p>The system has problem and needs to be repaired.</p>

### NOTE:

When diagnosis sensor unit is replaced with new one, "AIR BAG" warning lamp will operate in User mode. Checking "AIR BAG" warning lamp operation in Diagnosis mode is not required. Go to step 6.

# TROUBLE DIAGNOSES — Supplemental Restraint System (SRS)

## Self-diagnosis (Cont'd)

- If "AIR BAG" warning lamp operates as shown in No. 1 in the chart above, turn ignition switch "OFF" to reset from Diagnosis mode to User mode. Then go to step 6.

If "AIR BAG" warning lamp operates as in No. 2 in chart above, the malfunctioning part is not repaired completely, or another malfunctioning part is detected. Go to DIAGNOSTIC PROCEDURE 3, page RS-25, and repair malfunctioning part completely.

- Turn ignition switch "ON". "AIR BAG" warning lamp operates in User mode. Compare "AIR BAG" warning lamp operation to the chart below.

### NOTE:

If switching Diagnosis mode to User mode is required while malfunction is being detected, turn ignition switch from "OFF" to "ON". Then press driver's door switch at least 5 times within 7 seconds after turning ignition switch "ON". SRS is now in User mode.

"AIR BAG" warning lamp operation — User mode —	SRS condition	Reference item
<p>MRS095A</p>	No malfunction is detected. No further action is necessary.	—
<p>MRS096A</p>	The system has problem and needs to be repaired as indicated.	Go to DIAGNOSTIC PROCEDURE 2 or 3 (RS-23 or 25).
<p>MRS097A</p>	Air bag is deployed.  Air bag fuse, diagnosis sensor unit or harness is malfunctioning and needs to be repaired.	Go to COLLISION DIAGNOSIS (RS-36).  Go to DIAGNOSTIC PROCEDURE 9 (RS-34).
<p>MRS098A</p>	One of the following has occurred and needs to be repaired. <ul style="list-style-type: none"> <li>• Meter fuse is blown.</li> <li>• "AIR BAG" warning lamp circuit has open or short.</li> <li>• Diagnosis sensor unit is malfunctioning.</li> </ul>	Go to DIAGNOSTIC PROCEDURE 10 (RS-34).

# TROUBLE DIAGNOSES — Supplemental Restraint System (SRS)

## Self-diagnosis (Cont'd)

### DIAGNOSTIC PROCEDURE 6 (Continued from DIAGNOSTIC PROCEDURE 2) ( with CONSULT)

Inspecting SRS malfunctioning record and checking battery voltage

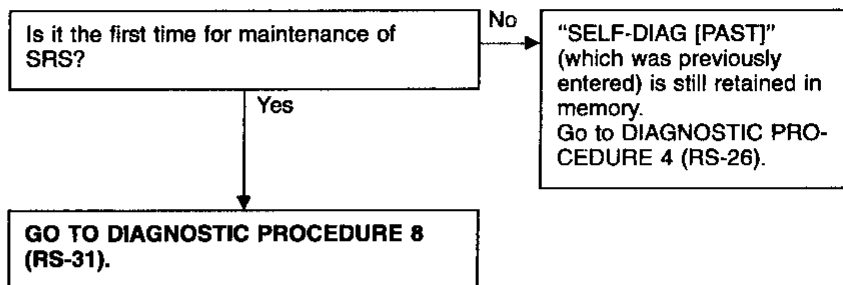

### DIAGNOSTIC PROCEDURE 7 (Continued from DIAGNOSTIC PROCEDURE 3) ( without CONSULT)

Inspecting SRS malfunctioning record and checking battery voltage

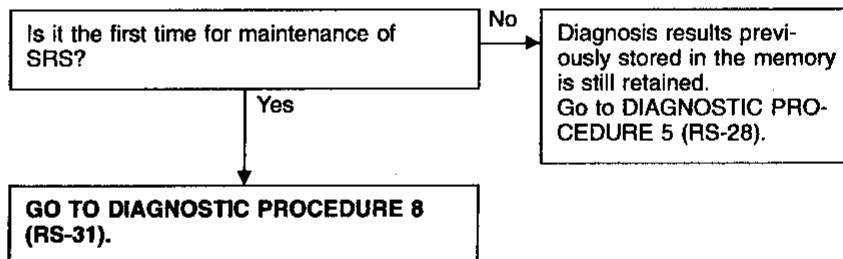

# TROUBLE DIAGNOSES — Supplemental Restraint System (SRS)

## Self-diagnosis (Cont'd)

### DIAGNOSTIC PROCEDURE 8 (CONSULT) with CONSULT

#### Inspecting SRS intermittent problem by using CONSULT — Diagnosis mode

1. Turn ignition switch "OFF".
2. Connect "CONSULT" to Data link connector.

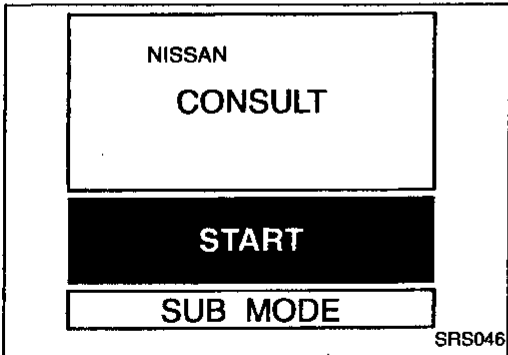
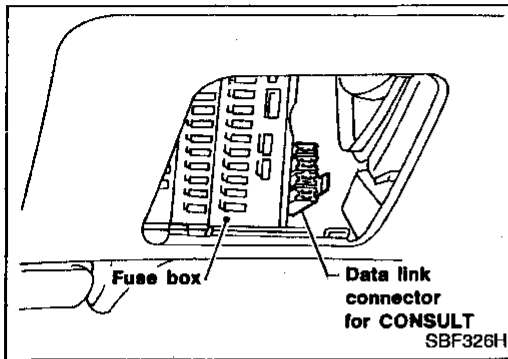

3. Turn ignition switch "ON".
4. Touch "START".

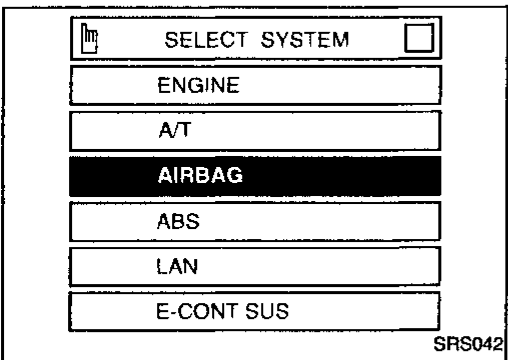

5. Touch "AIRBAG".

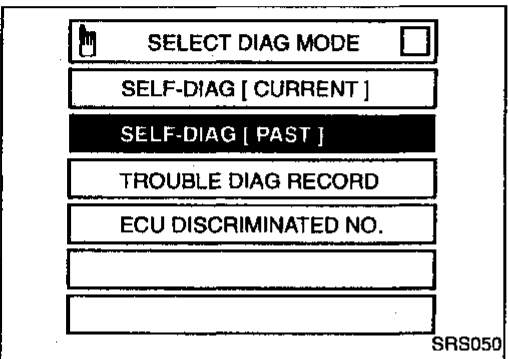

6. Touch "SELF-DIAG [PAST]".

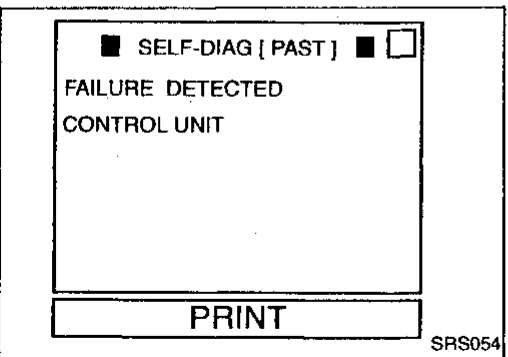

7. If diagnostic codes are displayed on "SELF-DIAG [PAST]", go to step 10.

GI

MA

EM

LC

EC

FE

CL

MT

AT

FA

RA

BR

ST

RS

BT

HA

EL

IDX

## TROUBLE DIAGNOSES — Supplemental Restraint System (SRS)

### Self-diagnosis (Cont'd)

If no self-diagnostic failure is detected on "SELF-DIAG [PAST]", touch "BACK" and go back to "SELECT DIAG MODE".

■ SELF-DIAG [ PAST ] ■

FAILURE DETECTED

\* NO SELF DIAGNOSTIC FAILURE INDICATED.

FURTHER TESTING MAY BE REQUIRED. \*\*

PRINT

SRS062

SELECT DIAG MODE

SELF-DIAG [ CURRENT ]

SELF-DIAG [ PAST ]

TROUBLE DIAG RECORD

ECU DISCRIMINATED NO.

SRS055

8. Touch "TROUBLE DIAG RECORD".

■ TROUBLE DIAG RECORD ■

FAILURE DETECTED

ASSIST A/B MODULE [ OPEN ]

PRINT

SRS056

9. Diagnostic code is displayed on "TROUBLE DIAG RECORD".

10. Touch "PRINT".
11. Compare diagnostic codes to the INTERMITTENT PROBLEM DIAGNOSTIC CODE CHART, page RS-33.
12. Touch "BACK" key of CONSULT until SELECT SYSTEM appears, then turn off CONSULT.
13. Turn ignition switch "OFF", then disconnect CONSULT and both battery cables.
14. Repair the system as outlined by the "Repair order" in INTERMITTENT PROBLEM DIAGNOSTIC CODE CHART, that corresponds to the problem code. For replacement procedure of component parts, refer to RS-8.
15. Go to DIAGNOSTIC PROCEDURE 4, page RS-26, for final-checking.



# TROUBLE DIAGNOSES — Supplemental Restraint System (SRS)

## Self-diagnosis (Cont'd)

### INTERMITTENT PROBLEM DIAGNOSTIC CODE CHART

Diagnostic item	Explanation	Repair order Recheck SRS at each replacement.	
NO SELF DIAGNOSTIC FAILURE INDICATED.	<ul style="list-style-type: none"> <li>No malfunction is detected.</li> </ul>	<ul style="list-style-type: none"> <li>Go to DIAGNOSTIC PROCEDURE 4 (RS-26) after charging battery.</li> </ul>	GI
AIRBAG MODULE [OPEN]	<ul style="list-style-type: none"> <li>Driver's air bag module circuit is open. (including the spiral cable)</li> </ul>	<ul style="list-style-type: none"> <li>Replace driver's air bag module. (Before disposal of it, it must be deployed.)</li> <li>Replace the diagnosis sensor unit.</li> <li>Replace the spiral cable.</li> <li>Replace the harness if it has visible damage.</li> </ul>	MA
AIRBAG MODULE [VB-SHORT]	<ul style="list-style-type: none"> <li>Driver's air bag module circuit is shorted to some power supply circuit. (including the spiral cable)</li> </ul>		EM
AIRBAG MODULE [GND-SHORT]	<ul style="list-style-type: none"> <li>Driver's air bag module circuit is shorted to ground. (including the spiral cable)</li> </ul>		LC
AIRBAG MODULE [SHORT]	<ul style="list-style-type: none"> <li>Driver's air bag module circuits are shorted to each other.</li> </ul>		EC
ASSIST A/B MODULE [VB-SHORT]	<ul style="list-style-type: none"> <li>Front passenger air bag module circuit is shorted to some power supply circuit.</li> </ul>	<ul style="list-style-type: none"> <li>Replace front passenger air bag module. (Before disposal of it, it must be deployed.)</li> <li>Replace the diagnosis sensor unit.</li> <li>Replace the harness if it has visible damage.</li> </ul>	FE
ASSIST A/B MODULE [OPEN]	<ul style="list-style-type: none"> <li>Front passenger air bag module circuit is open.</li> </ul>		CL
ASSIST A/B MODULE [GND-SHORT]	<ul style="list-style-type: none"> <li>Front passenger air bag module circuit is shorted to ground.</li> </ul>		MT
ASSIST A/B MODULE [SHORT]	<ul style="list-style-type: none"> <li>Front passenger air bag module circuits are shorted to each other.</li> </ul>		AT
CONTROL UNIT	<ul style="list-style-type: none"> <li>Diagnosis sensor unit is out of order.</li> </ul>	<ul style="list-style-type: none"> <li>Replace the diagnosis sensor unit.</li> </ul>	FA

\* Intermittent problem areas cannot be easily located. For this reason, perform the procedures outlined under the repair order, then make the final system check.

FA

RA

BR

ST

RS

BT

HA

EL

IDX

# TROUBLE DIAGNOSES — Supplemental Restraint System (SRS)

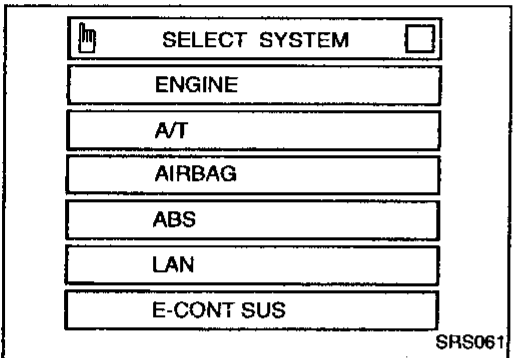
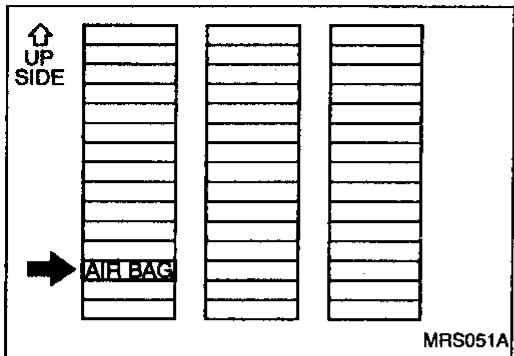

## Trouble Diagnoses for Air Bag Warning Lamp DIAGNOSTIC PROCEDURE 9

**SYMPTOM: "AIR BAG" warning lamp does not turn off.**

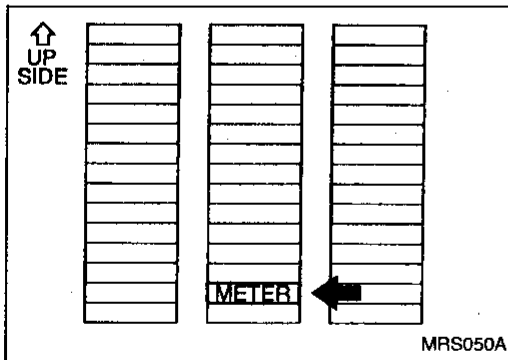
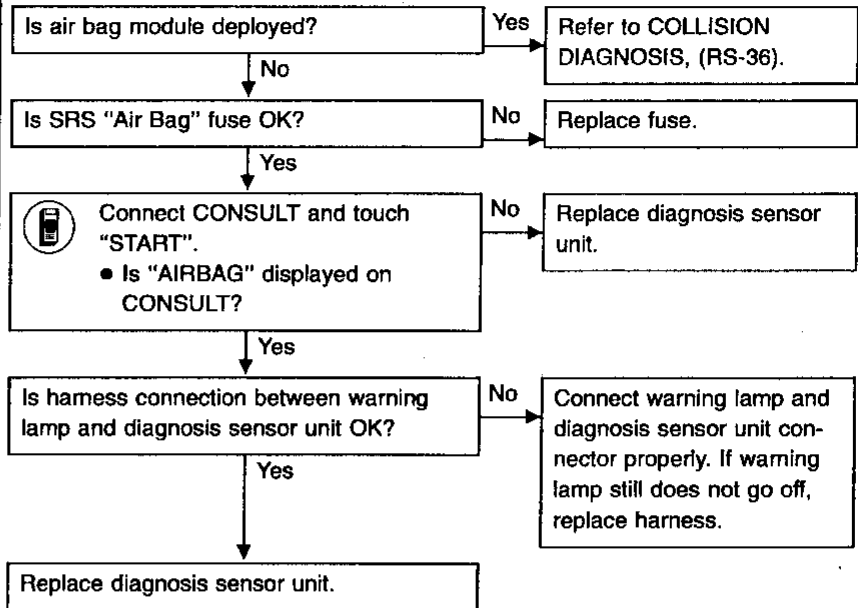

## DIAGNOSTIC PROCEDURE 10

**SYMPTOM: "AIR BAG" warning lamp does not turn on.**

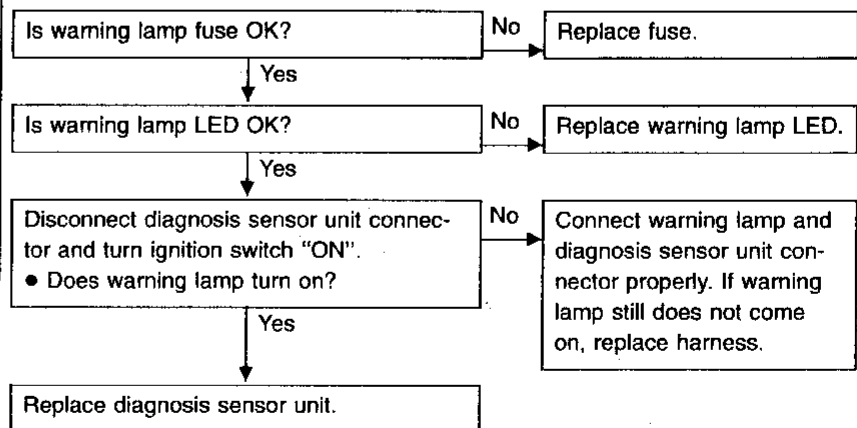

# TROUBLE DIAGNOSES — Supplemental Restraint System (SRS)

## Trouble Diagnoses for Air Bag Warning Lamp

(Cont'd)

### DIAGNOSTIC PROCEDURE 11

SYMPTOM: SRS does not enter Diagnostic mode.

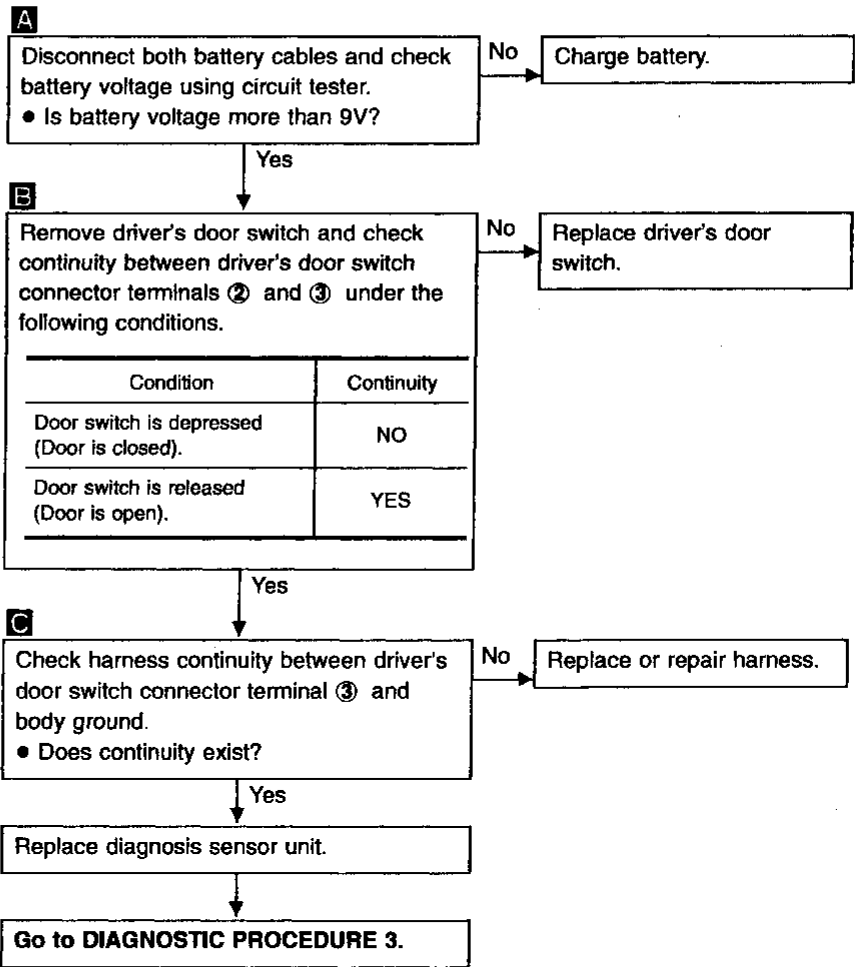
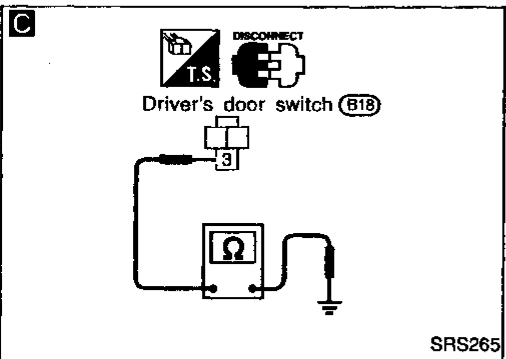
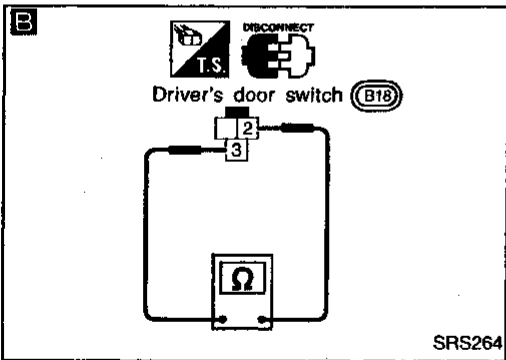
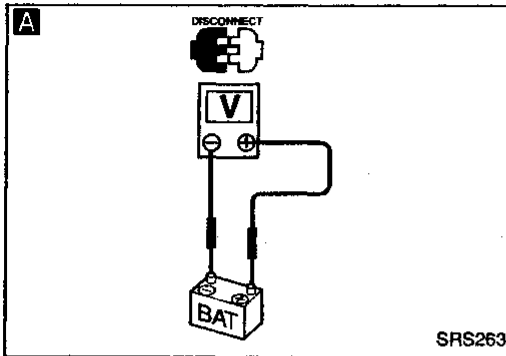

GI  
MA  
EM  
LC  
EC  
FE  
CL  
MT  
AT  
FA  
RA  
BR  
ST  
RS  
BT  
HA  
EL  
IDX

# COLLISION DIAGNOSIS

To repair the SRS, perform the following steps.

**When SRS is activated in a collision:**

- ① Replace the diagnosis sensor unit.
- ② Remove the air bag modules.
- ③ Check the SRS components using the table shown below:
  - Replace any SRS components showing visible signs of damage (dents, cracks, deformation).
- ④ Install new air bag modules.
- ⑤ Conduct self-diagnosis using CONSULT and "AIR BAG" warning lamp. Refer to "Self-diagnosis" for details (RS-22). Ensure entire SRS operates properly.

**When SRS is not activated in a collision:**

- ① Check the SRS components using the table shown below:
  - Replace any SRS components showing visible signs of damage (dents, cracks, deformation).
- ② Conduct self-diagnosis using CONSULT and "AIR BAG" warning lamp. Refer to "Self-diagnosis" for details (RS-22). Ensure entire SRS operates properly.

**SRS inspection**

Part	SRS is activated	SRS is NOT activated
Air bag module (driver and passenger side)	REPLACE Install with new bolts.	1. Remove air bag module. Check harness cover and connectors for damage, terminals for deformities, and harness for binding. 2-1. Install driver air bag module into the steering wheel to check fit and alignment with the wheel. 2-2. Install passenger air bag module into the instrument panel to check fit with the instrument panel. 3. No damage found, reinstall with new bolts. 4. If damaged—REPLACE. Air bag must be deployed before discarding.
Diagnosis sensor unit	REPLACE Install with new bolts.	1. Check case for dents, cracks or deformities. 2. Check connectors for damage, and terminals for deformities. 3. If no damage is found, reinstall with new bolts. 4. If damaged—REPLACE.
Instrument panel	1. Check instrument panel for bending, deformities, or cracks. 2. Check passenger side module brackets for dents, cracks or deformities. 3. If no damage is found, reinstall with new bolts. 4. If damaged—REPLACE.	
Steering wheel	1. Visually check steering wheel for deformities. 2. Check harness (built into steering wheel) and connectors for damage, and terminals for deformities. 3. Install air bag module to check fit or alignment with steering wheel. 4. Check steering wheel for excessive free play. 5. If no damage is found, reinstall with new bolts. 6. If damaged—REPLACE.	
Spiral cable	1. Visually check spiral cable and combination switch for damage. 2. Check connectors, and protective tape for damage. 3. Check steering wheel for noise, binding or heavy operation. 4. If no damage is found, reinstall with new bolts. 5. If damaged—REPLACE.	
Harness and Connectors	1. Check connectors for poor connection, damage, and terminals for deformities. 2. Check harness for binding, chafing, cuts, or deformities. 3. If no damage is found, reinstall the harness and connector. 4. Damaged—REPLACE damaged section of harness. Do not attempt to repair, splice or modify any SRS harness.	