

REAR AXLE & REAR SUSPENSION

SECTION **RA**

GI
MA
EM
LC
EC
FE
CL
MT
AT
FA
RA
BR
ST
RS
BT
HA
EL
IDX

CONTENTS

PRECAUTIONS AND PREPARATION	2	REAR AXLE	6
Precautions.....	2	Wheel Hub.....	6
Special Service Tools.....	2	REAR SUSPENSION	9
Commercial Service Tools.....	2	Removal and Installation.....	10
REAR SUSPENSION SYSTEM	3	Coil Spring and Shock Absorber.....	10
ON-VEHICLE SERVICE	4	Torsion Beam, Lateral Link and Control Rod.....	12
Rear Axle and Rear Suspension Parts.....	4	SERVICE DATA AND SPECIFICATIONS (SDS)	13
Rear Wheel Bearing.....	4	General Specifications.....	13
Rear Wheel Alignment.....	5	Inspection and Adjustment.....	13

PRECAUTIONS AND PREPARATION

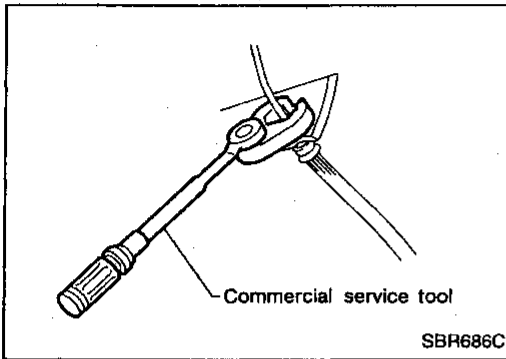

Precautions

- When installing each rubber part, final tightening must be carried out under unladen condition* with tires on ground.
- *: Fuel, radiator coolant and engine oil full. Spare tire, jack, hand tools and mats in designated positions.
- Use flare nut wrench when removing or installing brake tubes.
- After installing removed suspension parts, check wheel alignment.
- Always torque brake lines when installing.

Special Service Tools

Tool number (Kent-Moore No.) Tool name	Description
HT71780000 (—) Spring compressor	<div style="display: flex; justify-content: space-between;"> <div style="width: 20%;"> NT144 </div> <div style="width: 50%; text-align: center;"> </div> <div style="width: 30%; text-align: right;"> Removing and installing coil spring </div> </div>
ST35652000 (—) Strut attachment	<div style="display: flex; justify-content: space-between;"> <div style="width: 20%;"> NT145 </div> <div style="width: 50%; text-align: center;"> </div> <div style="width: 30%; text-align: right;"> Fixing strut assembly </div> </div>
ST15310000 (—) Drift	<div style="display: flex; justify-content: space-between;"> <div style="width: 20%;"> NT607 </div> <div style="width: 50%; text-align: center;"> </div> <div style="width: 30%; text-align: right;"> a: 84 mm (3.31 in) dia. b: 96 mm (3.78 in) dia. c: 8 mm (0.31 in) d: 20 mm (0.79 in) </div> </div>

Commercial Service Tools

Tool name	Description
① Flare nut crowfoot ② Torque wrench	<div style="display: flex; justify-content: space-between;"> <div style="width: 20%;"> NT360 </div> <div style="width: 50%; text-align: center;"> </div> <div style="width: 30%; text-align: right;"> Removing and installing brake piping a: 10 mm (0.39 in) </div> </div>
Drift	<div style="display: flex; justify-content: space-between;"> <div style="width: 20%;"> NT371 </div> <div style="width: 50%; text-align: center;"> </div> <div style="width: 30%; text-align: right;"> a: 75 mm (2.95 in) dia. b: 62 mm (2.44 in) dia. </div> </div>

REAR SUSPENSION SYSTEM

SEC. 431

When installing each rubber part, final tightening must be carried out under unladen condition* with tires on ground.

* Fuel, radiator coolant and engine oil full.
Spare tire, jack, hand tools and mats in designated positions.

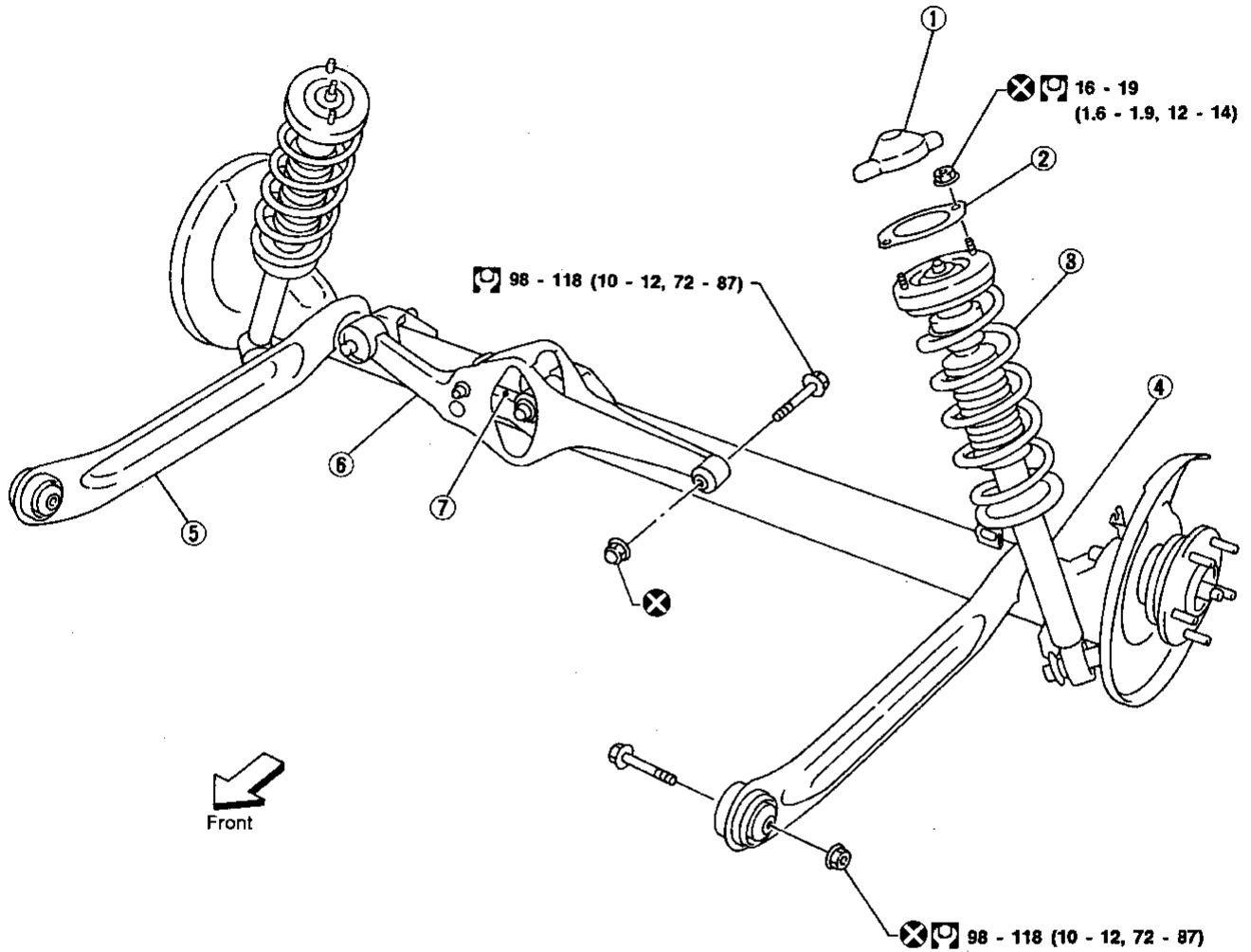

: N·m (kg-m, ft-lb)

- ① Shock absorber cap
- ② Shock absorber mounting seal
- ③ Coil spring

- ④ Shock absorber
- ⑤ Torsion beam

- ⑥ Lateral link
- ⑦ Control rod

SRA688A

GI

MA

EM

LC

EC

FE

CL

MT

AT

FA

RA

BR

ST

RS

BT

HA

EL

IDX

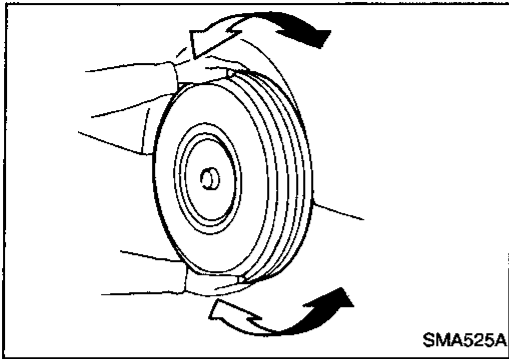

Rear Axle and Rear Suspension Parts

Check axle and suspension parts for looseness, wear or damage.

- Shake each rear wheel to check for excessive play.

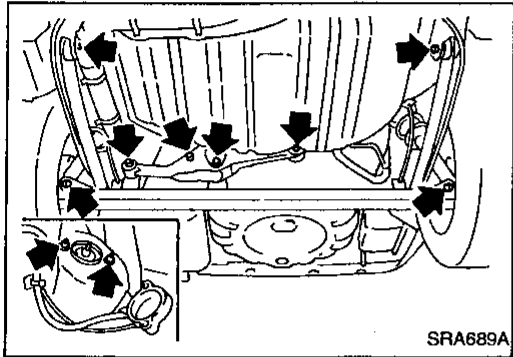

- Retighten all nuts and bolts to the specified torque.
Tightening torque:
Refer to REAR SUSPENSION (RA-9).

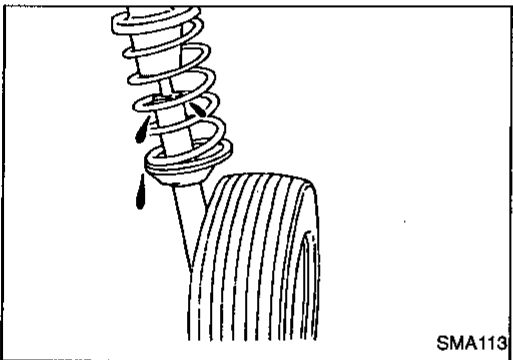

- Check shock absorber for oil leakage or other damage.
- Check wheelarch height. Refer to FA section.

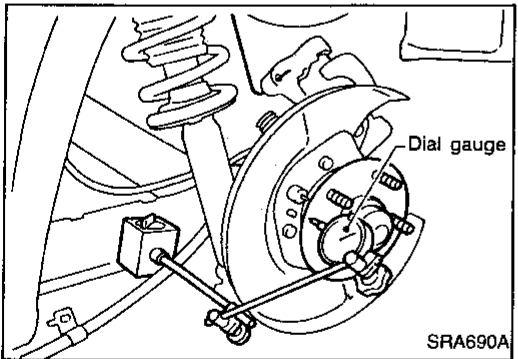

Rear Wheel Bearing

- Check axial end play.
Axial end play:
0.05 mm (0.0020 in) or less
- Check that wheel hub bearings operate smoothly.
- Check tightening torque of wheel bearing lock nut.
: 186 - 255 N·m
(19 - 26 kg·m, 137 - 188 ft·lb)
- Replace wheel bearing assembly if there is axial end play or wheel bearing does not turn smoothly. Refer to REAR AXLE — Wheel Hub (RA-6).

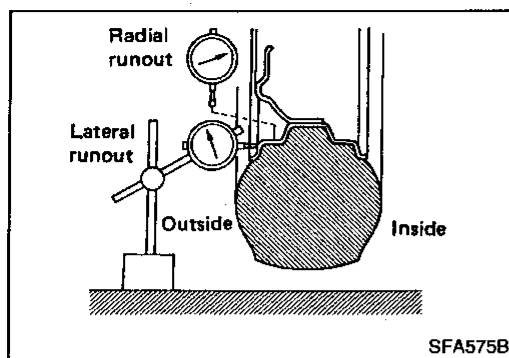

Rear Wheel Alignment

PRELIMINARY INSPECTION

Make following checks. Adjust, repair or replace if necessary.

- Check tires for wear and for improper inflation.
- Check rear wheel bearings for looseness.
- Check wheel runout.

Wheel runout: Refer to SDS in FA section.

- Check that rear shock absorber works properly.
- Check rear axle and rear suspension parts for looseness.
- Check vehicle posture (Unladen*).

*: Fuel, radiator coolant and engine oil full. Spare tire, jack, hand tools and mats in designated positions.

GI

MA

EM

LC

EC

FE

CL

MT

AT

FA

RA

BR

ST

RS

BT

HA

EL

IDX

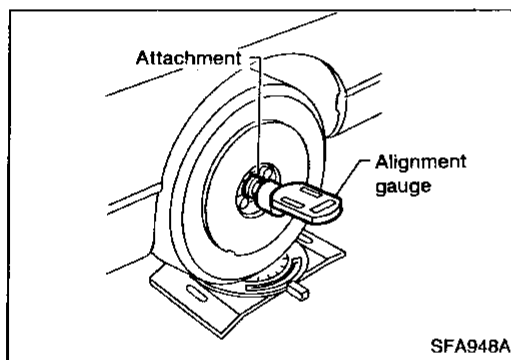

CAMBER

Camber is preset at factory and cannot be adjusted.

Camber:

Refer to SDS (RA-13).

- If the camber is not within specification, inspect and replace any damaged or worn rear suspension parts.

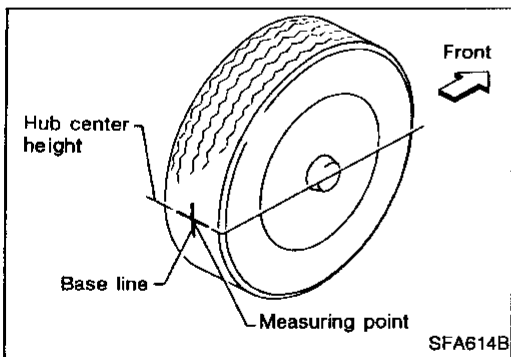

TOE-IN

Toe-in is preset at factory and cannot be adjusted.

Measure toe-in using following procedure. If out of specification, inspect and replace any damaged or worn rear suspension parts.

WARNING

- Perform following procedure always on a flat surface.
 - Make sure that no person is in front of the vehicle before pushing it.
1. Move rear of vehicle up and down to stabilize the posture.
 2. Push the vehicle straight ahead about 5m (196.9 in).
 3. Put a mark on base line of the tread (rear side) at the same height of hub center to be a measuring point.
 4. Measure distance "A" (rear side).
 5. Push the vehicle slowly ahead to turn the wheels around 180 degrees.

If the wheels have passed 180 degrees, try the above procedure again from the beginning. Never push vehicle backward.

6. Measure distance "B" (front side).

Total toe-in (A - B):

Total toe-in angle:

Refer to SDS (RA-13).

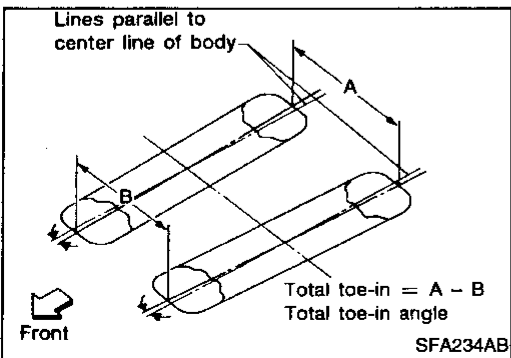

REAR AXLE

Wheel Hub

SEC. 430

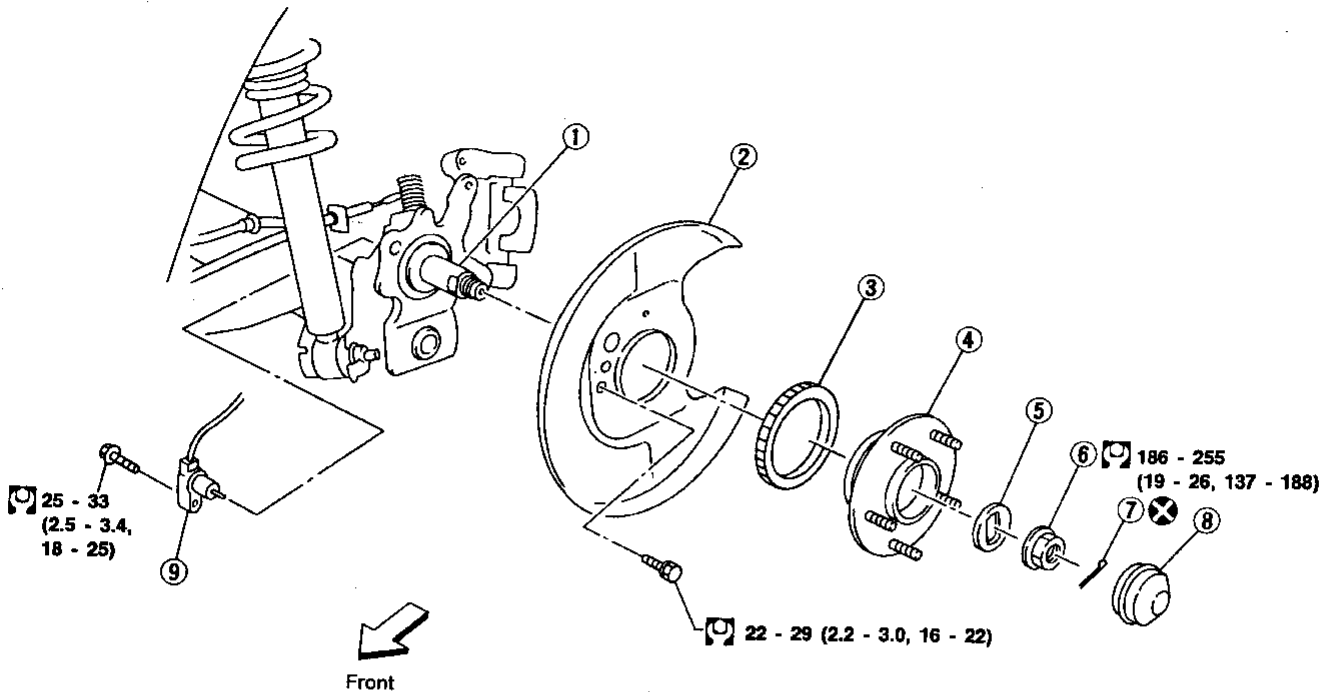

: N·m (kg-m, ft-lb)

SRA732A

- ① Spindle
- ② Baffle plate
- ③ ABS sensor rotor

- ④ Wheel hub bearing
- ⑤ Washer
- ⑥ Wheel bearing lock nut

- ⑦ Cotter pin
- ⑧ Hub cap
- ⑨ ABS sensor

REMOVAL

CAUTION:

- Before removing the rear wheel hub assembly, disconnect the ABS wheel sensor from the assembly. Then move it away from the hub assembly. Failure to do so may result in damage to the sensor wires and the sensor becoming inoperative.
- Wheel hub bearing usually does not require maintenance. If any of the following symptoms are noted, replace wheel hub bearing assembly.
- Growling noise is emitted from wheel hub bearing during operation.
- Wheel hub bearing drags or turns roughly. This occurs when turning hub by hand after bearing lock nut is tightened to specified torque.

REAR AXLE

Wheel Hub (Cont'd)

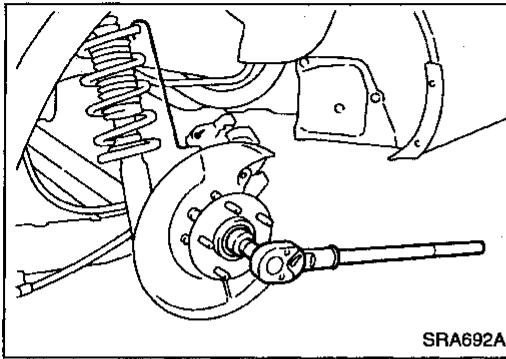

- 1) Remove brake caliper assembly.
 - 2) Remove wheel bearing lock nut.
- Remove brake caliper assembly and rotor.

Suspend caliper assembly with wire so as not to stretch brake hose.

Be careful not to depress brake pedal, or piston will pop out. Make sure brake hose is not twisted.

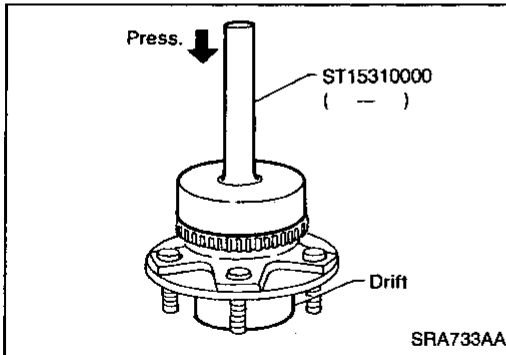

INSTALLATION

- With vehicles equipped with ABS, press-fit ABS sensor rotor into wheel hub bearing using a drift.

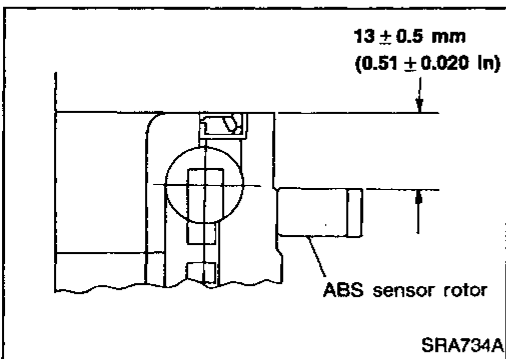

- Press-fit ABS sensor rotor as far as the location shown in figure at left.

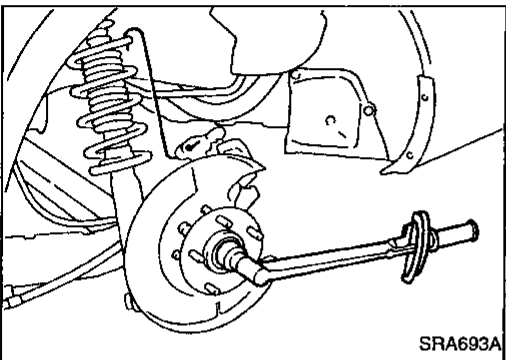

- Install wheel hub bearing.
- Tighten wheel bearing lock nut. Before tightening, apply oil to threaded portion of rear spindle and both sides of plain washer.
⚙: 186 - 255 N·m
(19 - 26 kg·m, 137 - 188 ft·lb)
- Check that wheel bearings operate smoothly.

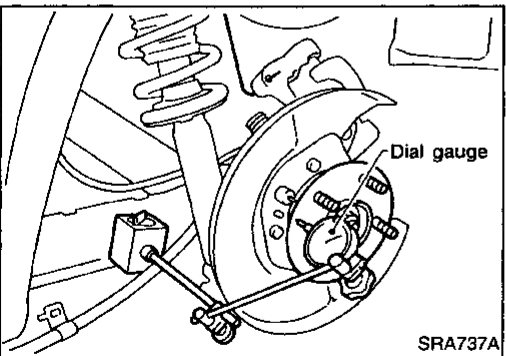

- Check wheel hub bearing axial end play.
Axial end play:
0.05 mm (0.0020 in) or less

REAR AXLE

Wheel Hub (Cont'd)

- Install hub cap using a suitable tool.
Do not reuse hub cap. When installing, replace it with a new one.

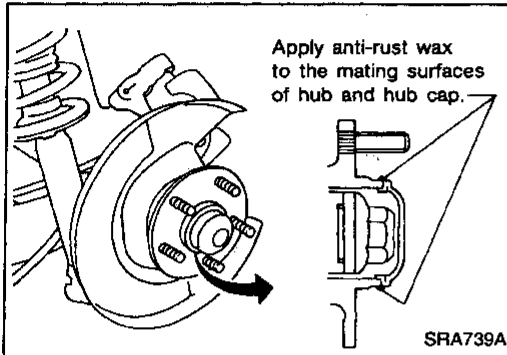
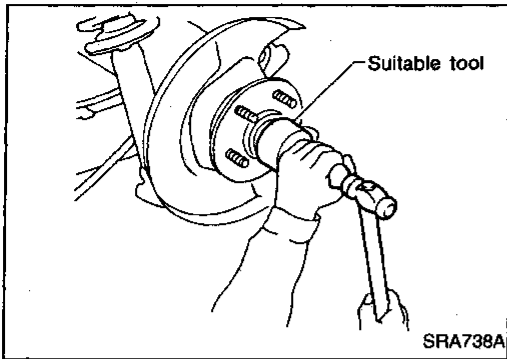

- Apply anti-rust wax to the mating surfaces of hub and hub cap.

REAR SUSPENSION

SEC. 431

When installing each rubber part, final tightening must be carried out under unladen condition* with tires on ground.

* Fuel, radiator coolant and engine oil full.
Spare tire, jack, hand tools and mats in designated positions.

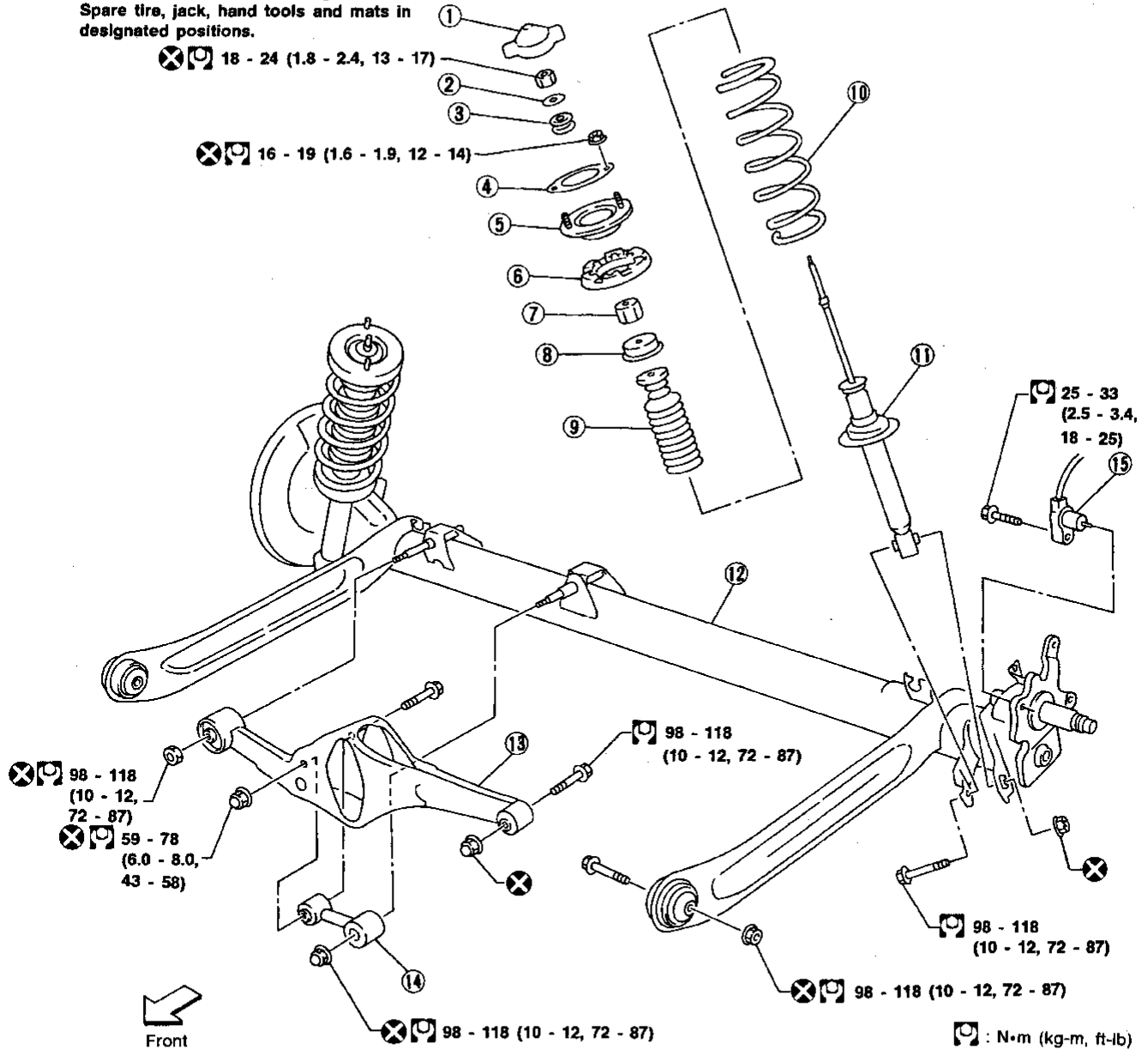

- | | | |
|-----------------------------------|----------------------------|------------------|
| ① Shock absorber cap | ⑥ Upper spring seat rubber | ⑩ Shock absorber |
| ② Washer | ⑦ Bushing | ⑫ Torsion beam |
| ③ Bushing | ⑧ Bound bumper cover | ⑬ Lateral link |
| ④ Shock absorber mounting seal | ⑨ Bound bumper | ⑭ Control rod |
| ⑤ Shock absorber mounting bracket | ⑪ Coil spring | ⑮ ABS sensor |

SRA694A

GI
MA
EM
LC
EC
FE
CL
MT
AT
FA
RA
BR
ST
RS
BT
HA
EL
IDX

REAR SUSPENSION

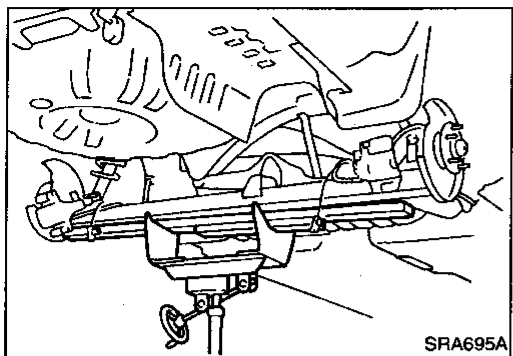

Removal and Installation

CAUTION:

- Before removing the rear suspension assembly, disconnect the ABS wheel sensor from the assembly. Failure to do so may result in damage to the sensor wires and the sensor becoming inoperative.

- Remove suspension assembly.
 1. Remove brake caliper assembly and rotor.

Suspend caliper assembly with wire so as not to stretch brake hose.

Be careful not to depress brake pedal, or piston will pop out. Make sure brake hose is not twisted.

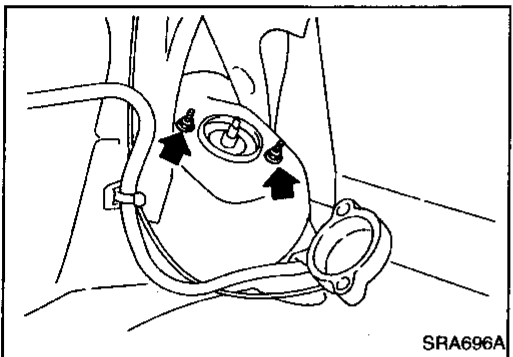

2. Using a transmission jack, raise torsion beam a little, and remove suspension fixing nuts and bolts.
3. Lower transmission jack, and remove suspension.
4. Remove luggage compartment trim. Refer to BT section.
5. Remove strut securing nuts (upper side). Then pull out strut assembly.

- Install suspension assembly.

1. Temporarily attach torsion beam to vehicle.

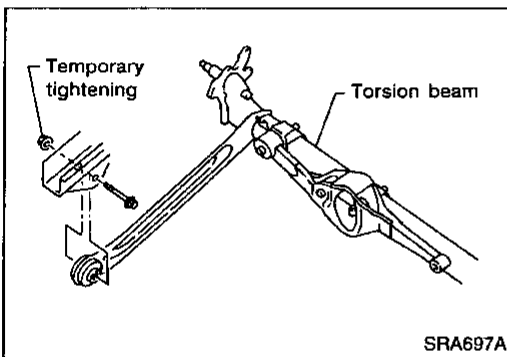

2. Place lateral link and control rod horizontally against torsion beam. Tighten up lateral link on vehicle.
3. Attach shock absorber to vehicle. Then tighten up the lower side of shock absorber.
4. Tighten torsion beam in full rebound condition at the place indicated in step 1.

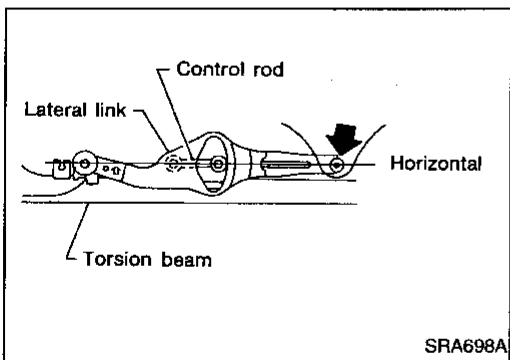

Coil Spring and Shock Absorber

REMOVAL

Remove shock absorber upper and lower fixing nuts.

Do not remove piston rod lock nut on vehicle.

REAR SUSPENSION

Coil Spring and Shock Absorber (Cont'd)

DISASSEMBLY

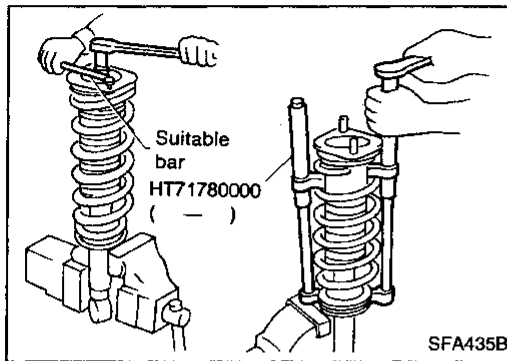

1. Set shock absorber in vise with attachment, then loosen piston rod lock nut.

Do not remove piston rod lock nut.

2. Compress spring with Tool so that the strut upper spring seat can be turned by hand.

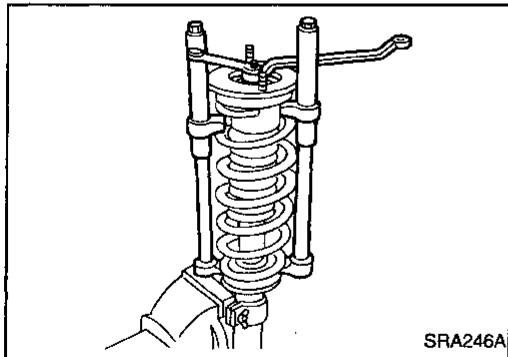

3. Remove piston rod lock nut.

INSPECTION

Shock absorber assembly

- Check for smooth operation through a full stroke, both compression and extension.
- Check for oil leakage on welded or gland packing portions.
- Check piston rod for cracks, deformation or other damage. Replace if necessary.

Upper rubber seat and bushing

Check rubber parts for deterioration or cracks. Replace if necessary.

Coil spring

Check for cracks, deformation or other damage. Replace if necessary.

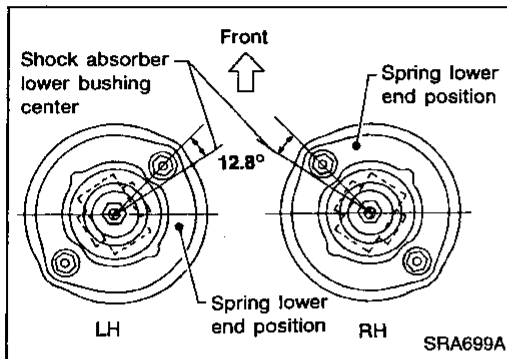

ASSEMBLY

- Locate upper spring seat as shown.

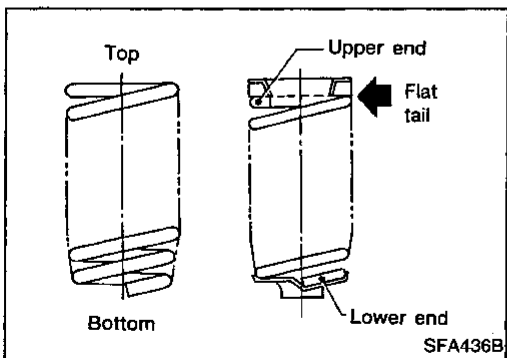

- When installing coil spring, be careful not to reverse top and bottom direction. (Top end is flat.)
- When installing coil spring on strut, it must be positioned as shown in figure at left.

REAR SUSPENSION

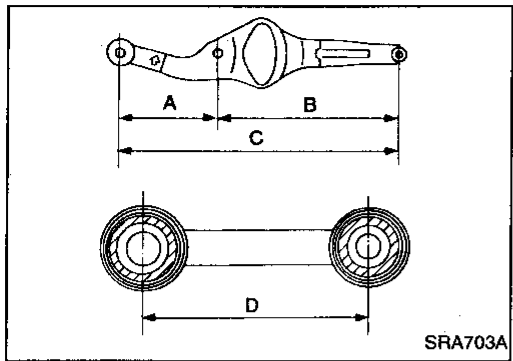

Torsion Beam, Lateral Link and Control Rod

DISASSEMBLY

- Remove torsion beam assembly. Refer to Removal and Installation in REAR SUSPENSION (RA-10).
- Remove lateral link and control rod from torsion beam.

INSPECTION

- Check for cracks, distortion or other damage. Replace if necessary.

Standard length:

- A 207 - 208 mm (8.15 - 8.19 in)
- B 394 - 395 mm (15.51 - 15.55 in)
- C 601 - 603 mm (23.66 - 23.74 in)
- D 106 - 108 mm (4.17 - 4.25 in)

- Check all rubber parts for wear, cracks or deformation. Replace if necessary.

ASSEMBLY

1. Temporarily assemble lateral link and control rod.
- When installing the control rod, connect the bush with the smaller inner diameter to the lateral link.

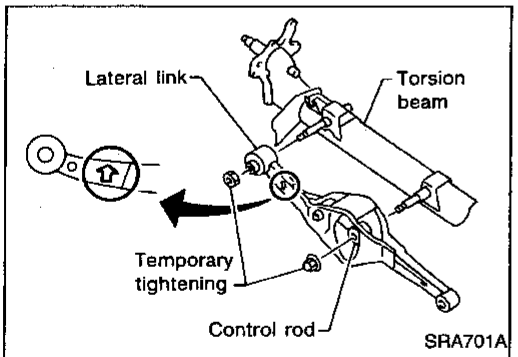
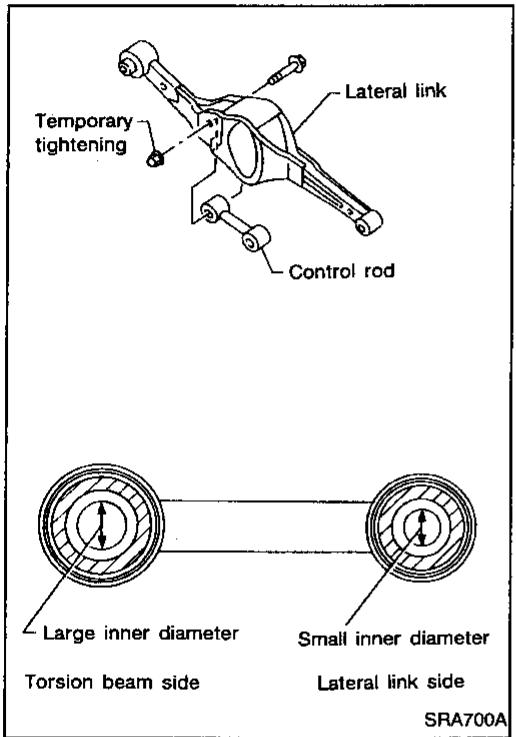

2. Temporarily install lateral link and control rod on torsion beam.
- When installing, place lateral link with the arrow topside.

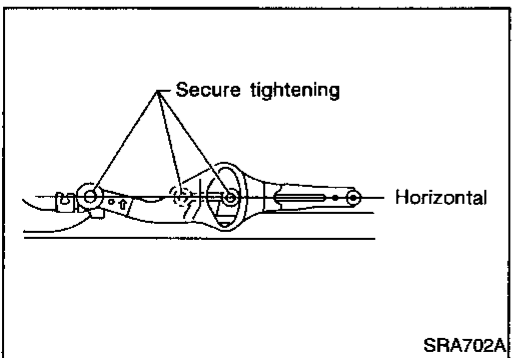

3. Place lateral link and control rod horizontally against torsion beam, and tighten to the specified torque.
4. Install torsion beam assembly. Refer to Removal and Installation in REAR SUSPENSION (RA-10).

SERVICE DATA AND SPECIFICATIONS (SDS)

General Specifications

COIL SPRING

Applied model	Luxury	Sporty
Wire diameter mm (in)	11.9 (0.469)	12.1 (0.476)
Coil outer diameter mm (in)	102.8 - 112.4 (4.05 - 4.43)	103.2 - 112.8 (4.06 - 4.44)
Free length mm (in)	320 (12.60)	310 (12.20)
Identification color		
RH	Yellow x 1, Gray x 1	Yellow x 1, Gray x 1, Blue x 1
LH	Blue x 1, Gray x 1	Blue x 1, Gray x 1, Blue x 1

SHOCK ABSORBER OR STRUT

Strut type	Double-acting hydraulic
Piston rod	
Rod diameter mm (in)	12.5 (0.492)

Inspection and Adjustment

WHEEL ALIGNMENT (Unladen*)

Camber	Minimum	-1°45' (-1.75°)
	Nominal	-1°00' (-1.00°)
	Maximum	-0°15' (-0.25°)
Total toe-in	Minimum	-3 (-0.12)
	Nominal	1 (0.04)
	Maximum	5 (0.20)
Angle (left plus right)	Minimum	-16' (0.27°)
	Nominal	5.5' (0.09°)
	Maximum	26' (0.43°)

*: Fuel, radiator coolant and engine oil full. Spare tire, jack, hand tools and mats in designated positions.

WHEEL BEARING

Wheel bearing axial end play mm (in)	0.05 (0.0020)
Wheel bearing lock nut tightening torque N-m (kg-m, ft-lb)	186 - 255 (19 - 26, 137 - 188)

GI

MA

EM

LC

EC

FE

CL

MT

AT

FA

RA

BR

ST

RS

BT

HA

EL

IDX