

## SECTION **BR**

### CONTENTS

<b>PRECAUTIONS AND PREPARATION</b> .....	2	Inspection — Rotor .....	13
Supplemental Restraint System (SRS) "AIR BAG" .....	2	Assembly .....	14
Precautions.....	2	Installation .....	14
Commercial Service Tools .....	2	<b>REAR DISC BRAKE</b> .....	15
<b>BRAKE HYDRAULIC LINE/CONTROL VALVE</b> .....	3	Pad Replacement.....	15
Brake Hydraulic Line .....	3	Removal.....	17
Dual Proportioning Valve .....	4	Disassembly .....	17
<b>CHECK AND ADJUSTMENT</b> .....	5	Inspection — Caliper .....	18
Checking Brake Fluid Level .....	5	Inspection — Rotor .....	19
Checking Brake Line .....	5	Assembly .....	19
Changing Brake Fluid .....	5	Installation .....	20
Bleeding Brake System .....	5	<b>PARKING BRAKE CONTROL</b> .....	21
<b>BRAKE PEDAL AND BRACKET</b> .....	6	Removal and Installation.....	21
Removal and Installation.....	6	Inspection .....	22
Inspection .....	6	Adjustment .....	22
Adjustment .....	6	<b>ANTI-LOCK BRAKE SYSTEM</b> .....	23
<b>MASTER CYLINDER</b> .....	7	Purpose .....	23
Removal.....	7	Operation.....	23
Disassembly .....	7	ABS Hydraulic Circuit.....	23
Inspection .....	8	System Components.....	24
Assembly .....	8	System Description .....	24
Installation .....	8	Removal and Installation.....	25
<b>BRAKE BOOSTER/VACUUM HOSE</b> .....	9	Wiring Diagram — ABS — .....	27
Brake Booster .....	9	<b>TROUBLE DIAGNOSES</b> .....	31
Vacuum Hose .....	10	Contents.....	31
<b>FRONT DISC BRAKE</b> .....	11	Component Parts and Harness Connector	
Pad Replacement.....	11	Location .....	41
Removal.....	12	<b>SERVICE DATA AND SPECIFICATIONS (SDS)</b> .....	63
Disassembly .....	12	General Specifications.....	63
Inspection — Caliper .....	13	Inspection and Adjustment.....	63

**When you read wiring diagrams:**

- Read GI section, "HOW TO READ WIRING DIAGRAMS".
- See EL section, "POWER SUPPLY ROUTING" for power distribution circuit.

**When you perform trouble diagnoses, read GI section, "HOW TO FOLLOW FLOW CHART IN TROUBLE DIAGNOSES" and "HOW TO PERFORM EFFICIENT DIAGNOSIS FOR AN ELECTRICAL INCIDENT".**

GI  
MA  
EM  
LC  
EC  
FE  
CL  
MT  
AT  
FA  
RA  
BR  
ST  
RS  
BT  
HA  
EL  
IDX

## PRECAUTIONS AND PREPARATION

### Supplemental Restraint System (SRS) "AIR BAG"

The Supplemental Restraint System "Air Bag", used along with a seat belt, helps to reduce the risk or severity of injury to the driver and front passenger in a frontal collision. The Supplemental Restraint System consists of air bag modules (located in the center of the steering wheel and on the instrument panel on the passenger side), a diagnosis sensor unit, warning lamp, wiring harness and spiral cable. Information necessary to service the system safely is included in the **RS section** of this Service Manual.

**WARNING:**

- To avoid rendering the SRS inoperative, which could increase the risk of personal injury or death in the event of a collision which would result in air bag inflation, all maintenance must be performed by an authorized INFINITI dealer.
- Improper maintenance, including incorrect removal and installation of the SRS, can lead to personal injury caused by unintentional activation of the system.
- All SRS electrical connectors are covered with yellow outer insulation. Do not use electrical test equipment on any circuit related to the SRS.

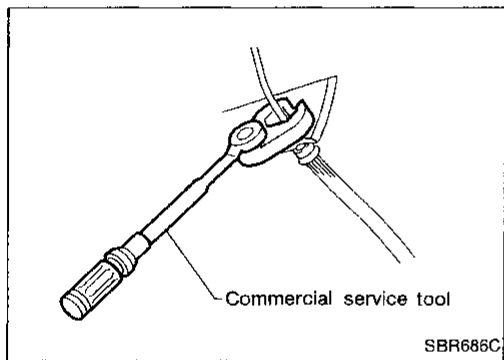

#### Precautions

- Recommended fluid is brake fluid "DOT 3".
- Never reuse drained brake fluid.
- Be careful not to splash brake fluid on painted areas.
- To clean or wash all parts of master cylinder, disc brake caliper and wheel cylinder, use clean brake fluid.
- Never use mineral oils such as gasoline or kerosene. They will ruin rubber parts of the hydraulic system.
- Use flare nut wrench when removing and installing brake tube.
- Always torque brake lines when installing.

**WARNING:**

- Clean brake pads and shoes with a waste cloth, then wipe with a dust collector.

#### Commercial Service Tools

Tool name	Description
① Flare nut crows foot ② Torque wrench	<p style="text-align: center;">NT360</p> <p style="text-align: right;">a: 10 mm (0.39 in)</p>
Brake fluid pressure gauge	<p style="text-align: center;">NT151</p>

## Brake Hydraulic Line

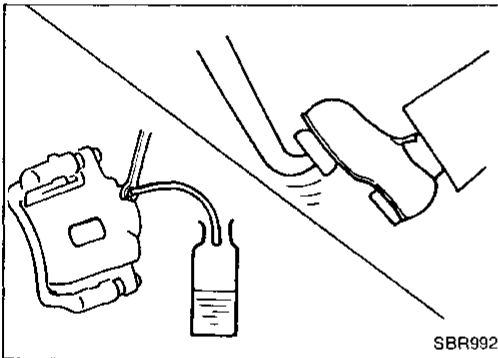
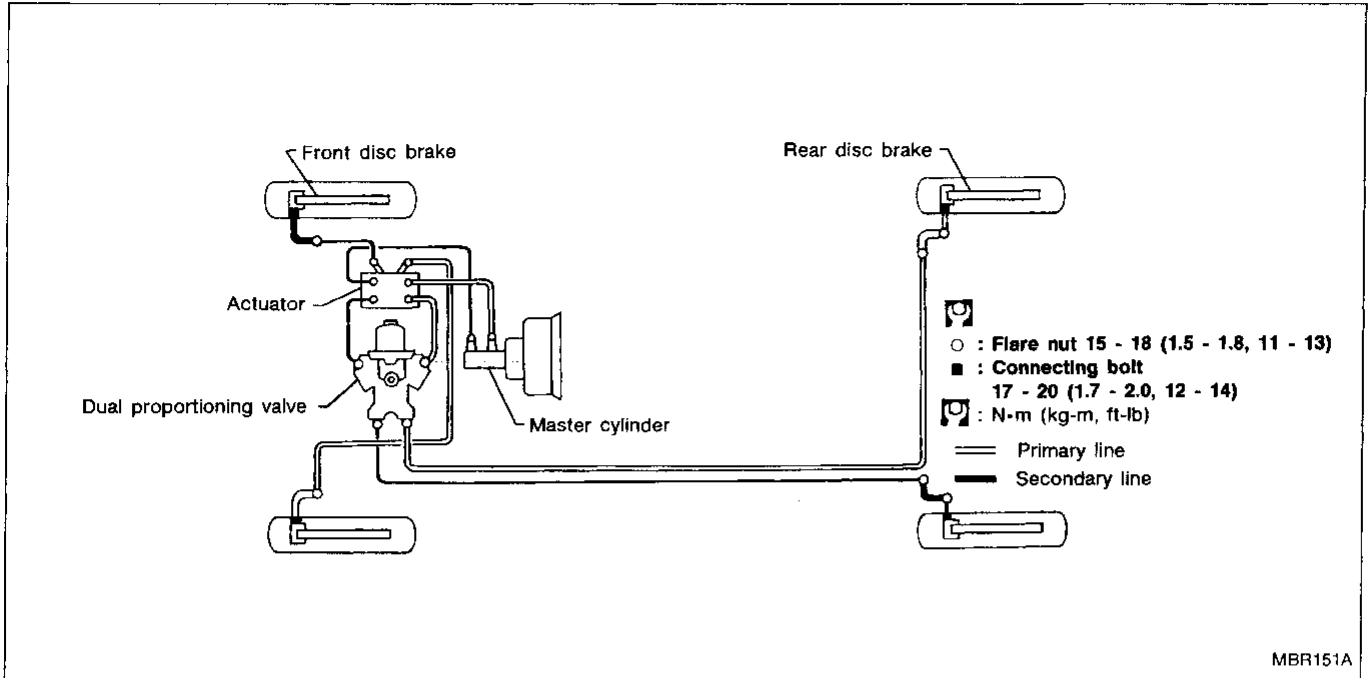

### REMOVAL

#### CAUTION:

- Be careful not to splash brake fluid on painted areas; it may cause paint damage. If brake fluid is splashed on painted areas, wash it away with water immediately.
  - All hoses must be free from excessive bending, twisting and pulling.
1. Connect vinyl tube to air bleeder valve.
  2. Drain brake fluid from each air bleeder valve by depressing brake pedal.
  3. Remove flare nut connecting brake tube and hose, then withdraw lock spring.
  4. Cover openings to prevent entrance of dirt whenever disconnecting brake line.

### INSPECTION

Check brake lines (tubes and hoses) for cracks, deterioration or other damage. Replace any damaged parts.

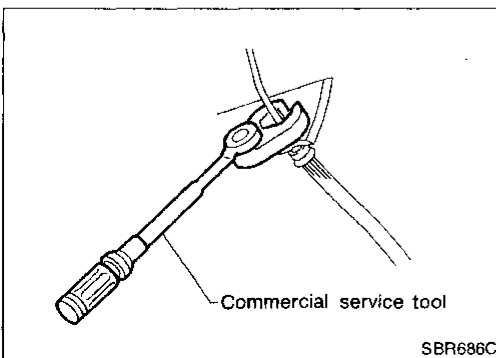

### INSTALLATION

#### CAUTION:

- Refill with new brake fluid "DOT 3".
  - Never reuse drained brake fluid.
1. Tighten all flare nuts and connecting bolts.

#### Specification:

##### Flare nut

15 - 18 N·m (1.5 - 1.8 kg-m, 11 - 13 ft-lb)

##### Connecting bolt

17 - 20 N·m (1.7 - 2.0 kg-m, 12 - 14 ft-lb)

# BRAKE HYDRAULIC LINE/CONTROL VALVE

## Brake Hydraulic Line (Cont'd)

2. Refill until new brake fluid comes out of each air bleeder valve.
3. Bleed air. Refer to "Bleeding Brake System" (BR-5).

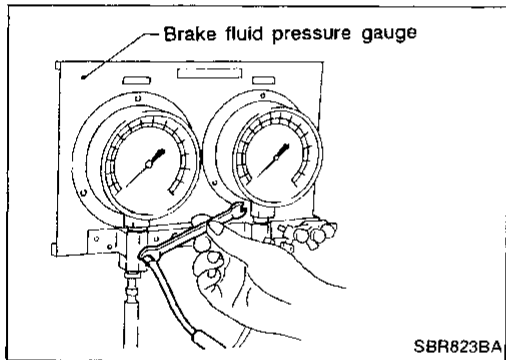
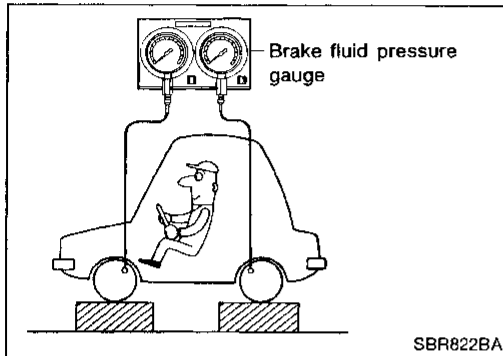

## Dual Proportioning Valve

### INSPECTION

#### CAUTION:

- Carefully monitor brake fluid level at master cylinder.
  - Use new brake fluid "DOT 3".
  - Be careful not to splash brake fluid on painted areas; it may cause paint damage. If brake fluid is splashed on paint areas, wash it away with water immediately.
1. Connect Tool to air bleeders of front and rear brakes on either LH and RH side.
  2. Bleed air from the Tool.
  3. Check fluid pressure by depressing brake pedal.

Unit: kPa (kg/cm<sup>2</sup>, psi)

Applied pressure (Front brake)	5,394 (55, 782)
Output pressure (Rear brake)	2,452 - 2,844 (25 - 29, 356 - 412)

4. Bleed air after disconnecting the Tool. Refer to "Bleeding Brake System" (BR-5).

# CHECK AND ADJUSTMENT

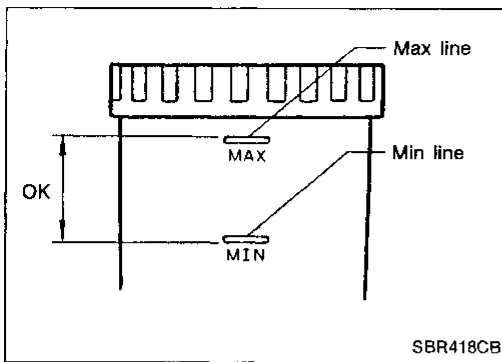

## Checking Brake Fluid Level

- Check fluid level in reservoir tank. It should be between Max and Min lines on reservoir tank.
- If fluid level is extremely low, check brake system for leaks.
- Release parking brake lever and see if brake warning lamp goes off. If not, check brake system for leaks.

## Checking Brake Line

### CAUTION:

If leakage occurs around joints, retighten or, if necessary, replace damaged parts.

1. Check brake lines (tubes and hoses) for cracks, deterioration or other damage. Replace any damaged parts.
2. Check for oil leakage by fully depressing brake pedal while engine is running.

## Changing Brake Fluid

### CAUTION:

- Refill with new brake fluid "DOT 3".
- Always keep fluid level higher than minimum line on reservoir tank.
- Never reuse drained brake fluid.
- Be careful not to splash brake fluid on painted areas; it may cause paint damage. If brake fluid is splashed on painted areas, wash it away with water immediately.

1. Clean inside of reservoir tank, and refill with new brake fluid.
2. Connect a vinyl tube to each air bleeder valve.
3. Drain brake fluid from each air bleeder valve by depressing brake pedal.
4. Refill until brake fluid comes out of each air bleeder valve. Use same procedure as in bleeding hydraulic system to refill brake fluid. Refer to "Bleeding Brake System" (BR-5).

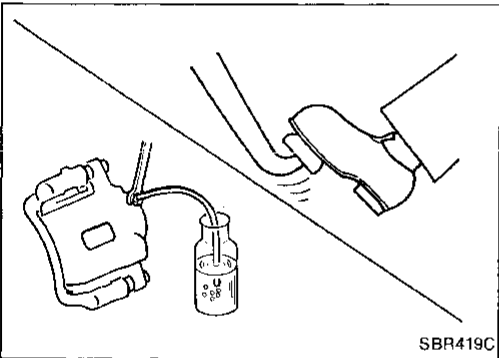
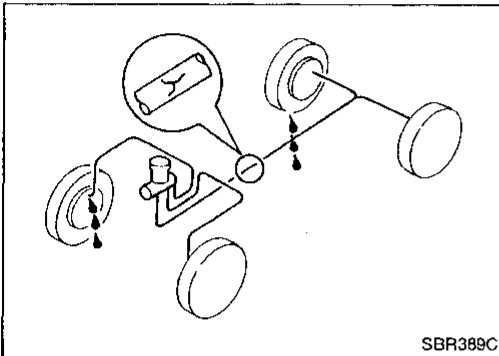

## Bleeding Brake System

### CAUTION:

- Carefully monitor brake fluid level at master cylinder during bleeding operation.
- Fill reservoir with new brake fluid "DOT 3". Make sure it is full at all times while bleeding air out of system.
- Place a container under master cylinder to avoid spillage of brake fluid.
- For models with ABS, turn ignition switch OFF and disconnect ABS actuator connectors or battery ground cable.

- Bleed air in the following order.

Right rear brake → Left front brake → Left rear brake → Right front brake

1. Connect a transparent vinyl tube to air bleeder valve.
2. Fully depress brake pedal several times.
3. With brake pedal depressed, open air bleeder valve to release air.
4. Close air bleeder valve.
5. Release brake pedal slowly.
6. Repeat steps 2. through 5. until clear brake fluid comes out of air bleeder valve.

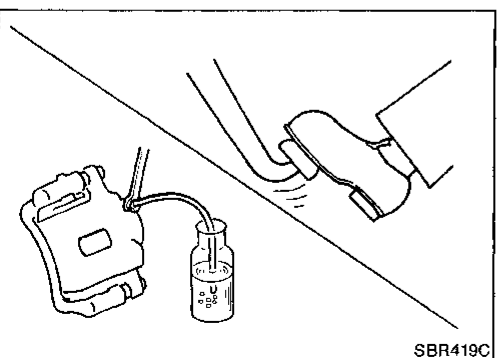
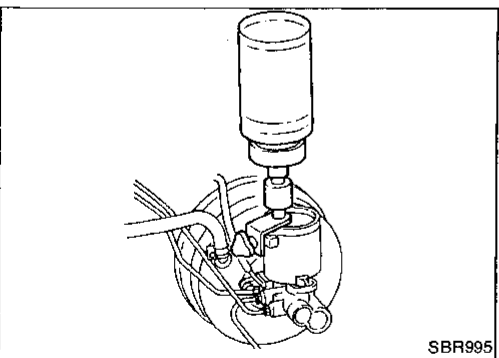

# BRAKE PEDAL AND BRACKET

## Removal and Installation

SEC. 465-470

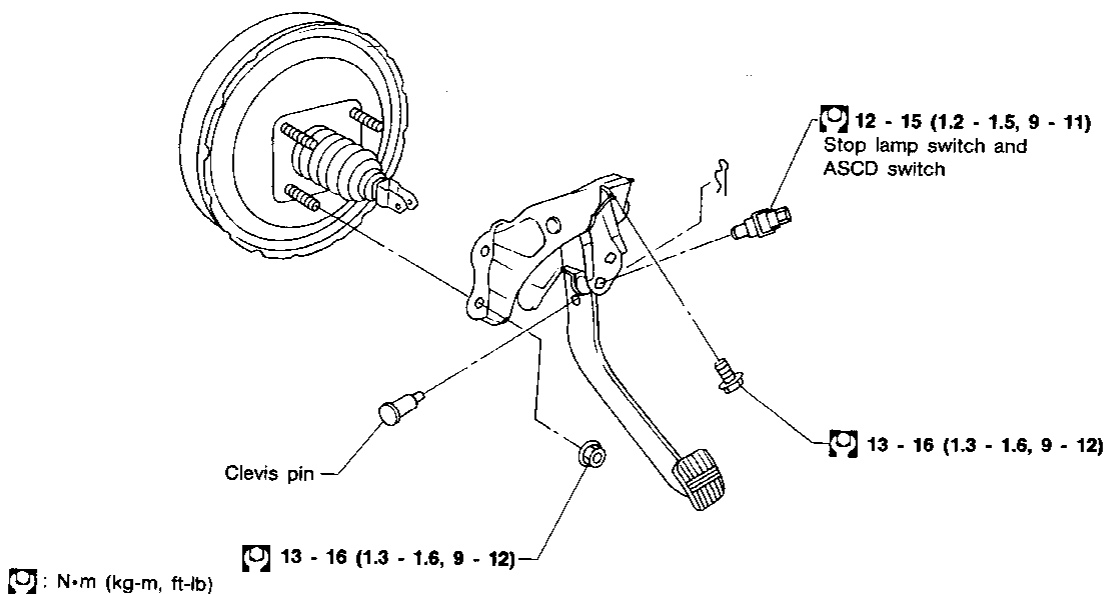

SBR565CB

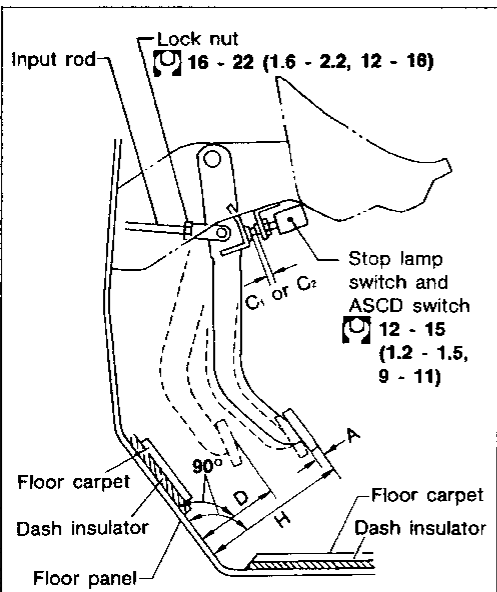

: N·m (kg-m, ft-lb)

SBR463CA

### Inspection

Check brake pedal for following items.

- Brake pedal bend
- Clevis pin deformation
- Crack of any welded portion

### Adjustment

Check brake pedal free height from dash reinforcement panel. Adjust if necessary.

- H:** Free height  
Refer to SDS (BR-63).
- D:** Depressed height  
Refer to SDS. (BR-63).  
Under force of 490 N (50 kg, 110 lb)  
with engine running
- $C_1$ ,  $C_2$ :** Clearance between pedal stopper and threaded  
end of stop lamp switch and ASC D switch  
0.3 - 1.0 mm (0.012 - 0.039 in)
- A:** Pedal free play  
1 - 3 mm (0.04 - 0.12 in)

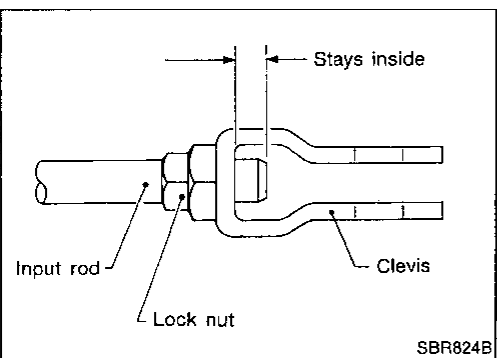

SBR824B

1. Loosen lock nut and adjust pedal free height by turning brake booster input rod. Then tighten lock nut.
2. Check pedal free play.

**Make sure that stop lamps go off when pedal is released.**

3. Check brake pedal's depressed height while engine is running. If lower than specification, check brake system for leaks, accumulation of air or any damage to components (master cylinder, wheel cylinder, etc.); then make necessary repairs.

# MASTER CYLINDER

SEC. 460

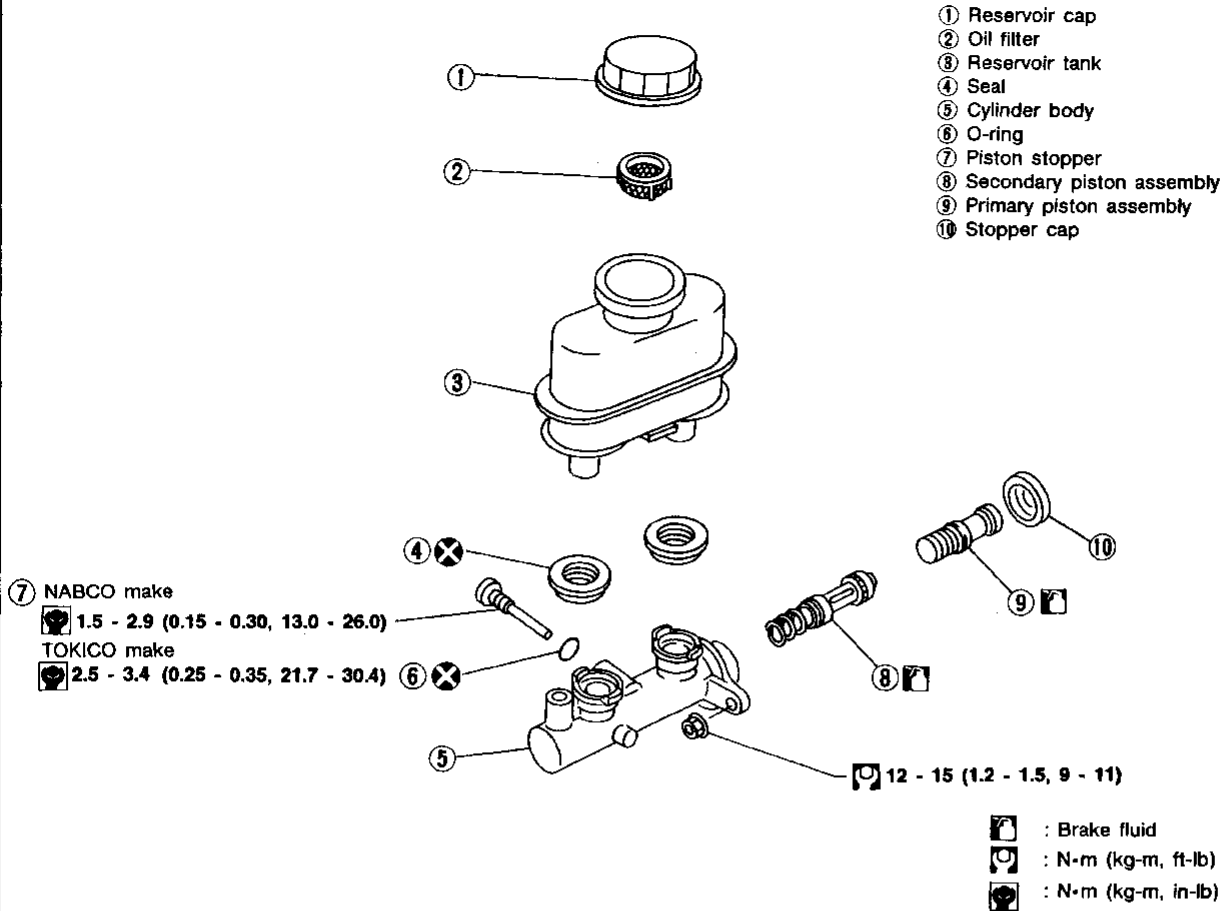

MBR153A

## Removal

### CAUTION:

Be careful not to splash brake fluid on painted areas; it may cause paint damage. If brake fluid is splashed on painted areas, wash it away with water immediately.

1. Connect a vinyl tube to air bleeder valve.
2. Drain brake fluid from each air bleeder valve, depressing brake pedal to empty fluid from master cylinder.
3. Remove brake pipe flare nuts.
4. Remove master cylinder mounting nuts.

## Disassembly

1. Bend claws of stopper cap outward.

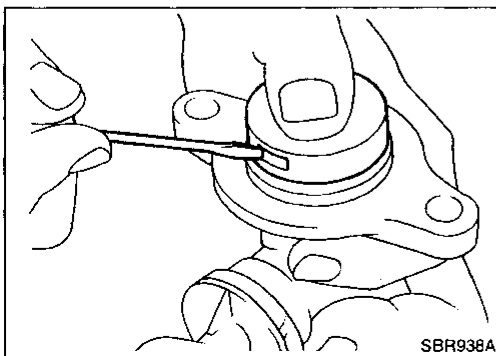

## MASTER CYLINDER

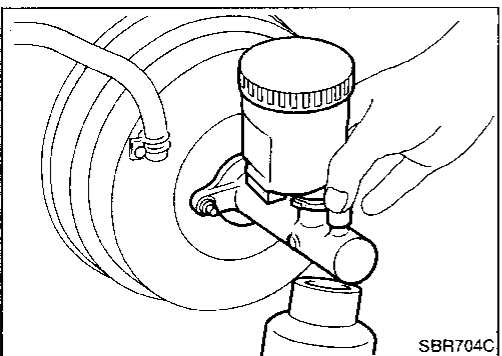
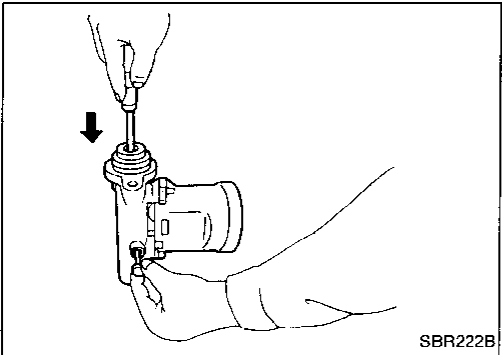
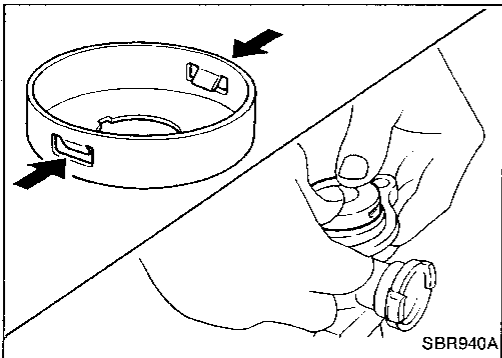
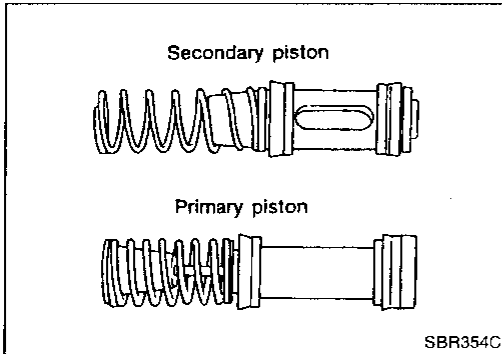
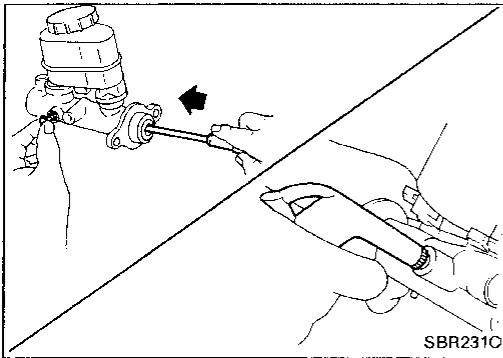

### Disassembly (Cont'd)

2. Remove valve stopper while piston is pushed into cylinder.
3. Remove piston assemblies.

**If it is difficult to remove secondary piston assembly, gradually apply compressed air through fluid outlet.**

4. Draw out reservoir tank.

### Inspection

Check for the following items.

**Replace any part if damaged.**

**Master cylinder:**

- Pin holes or scratches on inner wall.

**Piston:**

- Deformation of or scratches on piston cups.

### Assembly

1. Insert secondary piston assembly. Then insert primary piston assembly.

- Pay attention to alignment of secondary piston slit with valve stopper mounting hole of cylinder body.

2. Install stopper cap.

**Before installing stopper cap, ensure that claws are bent inward.**

3. Push reservoir tank seals into cylinder body.
4. Push reservoir tank into cylinder body.

5. Install valve stopper while piston is pushed into cylinder.

### Installation

**CAUTION:**

- Refill with new brake fluid "DOT 3".
- Never reuse drained brake fluid.

1. Place master cylinder onto brake booster and secure mounting nuts lightly.
2. Torque mounting nuts.

**12 - 15 N·m (1.2 - 1.5 kg-m, 9 - 11 ft-lb)**

3. Fill up reservoir tank with new brake fluid.
4. Plug all ports on master cylinder with fingers to prevent air suction while releasing brake pedal.
5. Have driver depress brake pedal slowly several times until no air comes out of master cylinder.
6. Fit brake lines to master cylinder.
7. Tighten flare nuts.

**15 - 18 N·m (1.5 - 1.8 kg-m, 11 - 13 ft-lb)**

8. Bleed air from brake system. Refer to "Bleeding Brake System" (BR-5).



# BRAKE BOOSTER/VACUUM HOSE

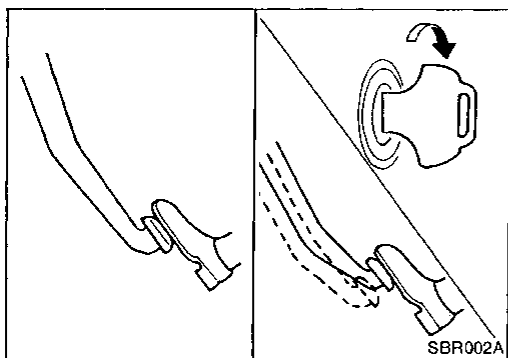

SBR002A

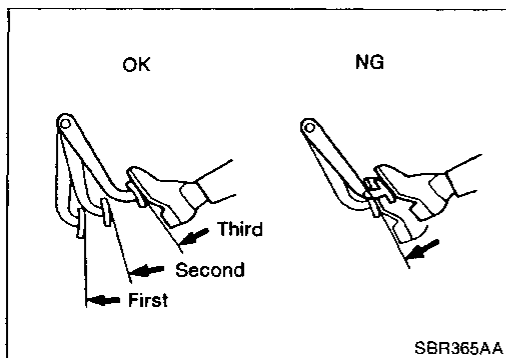

SBR365AA

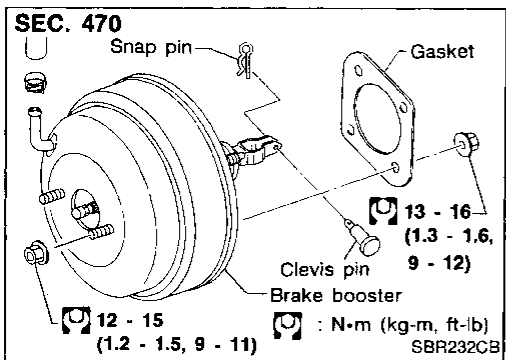

SBR232CB

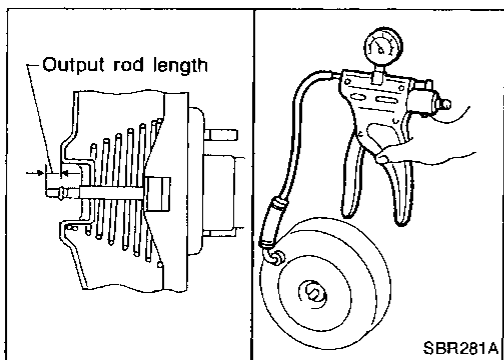

SBR281A

## Brake Booster

### ON-VEHICLE SERVICE

#### Operating check

- Stop engine and depress brake pedal several times. Check that pedal stroke does not change.
- Depress brake pedal, then start engine. If pedal goes down slightly, operation is normal.

#### Airtight check

- Start engine, and stop it after one or two minutes. Depress brake pedal several times slowly. The pedal should go further down the first time, and then it should gradually rise thereafter.
- Depress brake pedal while engine is running, and stop engine with pedal depressed. The pedal stroke should not change after holding pedal down for **30 seconds**.

### REMOVAL

#### CAUTION:

- Be careful not to splash brake fluid on painted areas; it may cause paint damage. If brake fluid is splashed on painted areas, wash it away with water immediately.
- Be careful not to deform or bend brake pipes, during removal of booster.

### INSPECTION

#### Output rod length check

1. Apply vacuum of  $-66.7 \text{ kPa}$  ( $-500 \text{ mmHg}$ ,  $-19.69 \text{ inHg}$ ) to brake booster with a handy vacuum pump.
2. Check output rod length.

#### Specified length:

10.275 - 10.525 mm (0.4045 - 0.4144 in)

### INSTALLATION

#### CAUTION:

- Be careful not to deform or bend brake pipes, during installation of booster.
- Replace clevis pin if damaged.
- Refill with new brake fluid "DOT 3".
- Never reuse drained brake fluid.
- Take care not to damage brake booster mounting bolt thread when installing. Due to the acute angle of installation, the threads can be damaged with the dash panel.

# BRAKE BOOSTER/VACUUM HOSE

## Brake Booster (Cont'd)

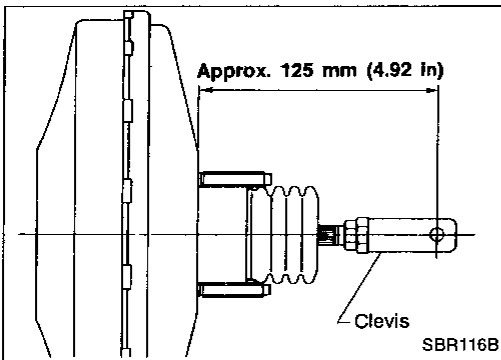

1. Before fitting booster, temporarily adjust clevis to dimension shown.
2. Fit booster, then secure mounting nuts (brake pedal bracket to master cylinder) lightly.
3. Connect brake pedal and booster input rod with clevis pin.
4. Secure mounting nuts.

**Specification: 13 - 16 N·m (1.3 - 1.6 kg-m, 9 - 12 ft-lb)**

5. Install master cylinder. Refer to "Installation" in "MASTER CYLINDER" (BR-8).
6. Bleed air. Refer to "Bleeding Brake System" (BR-5).

## Vacuum Hose

### REMOVAL AND INSTALLATION

#### CAUTION:

When installing vacuum hoses, pay attention to the following points.

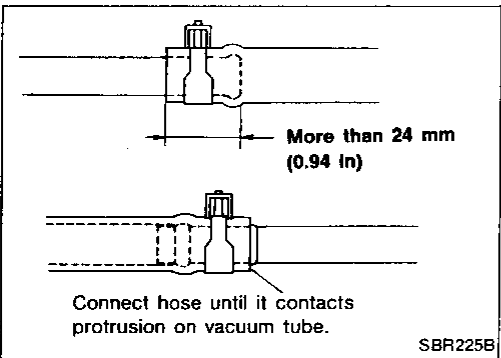

- Do not apply any oil or lubricants to vacuum hose and check valve.
- Insert vacuum tube into vacuum hose as shown.

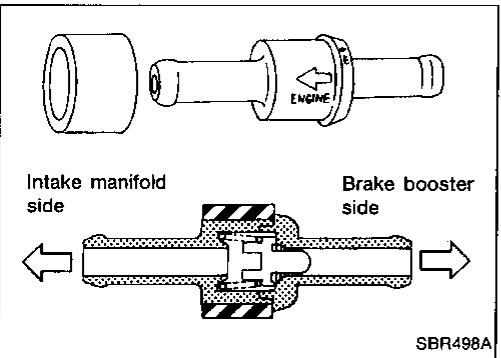

- Install check valve, paying attention to its direction.

## INSPECTION

### Hoses and connectors

Check vacuum lines, connections and check valve for airtightness, improper attachment chafing and deterioration.

### Check valve

Check vacuum with a vacuum pump.

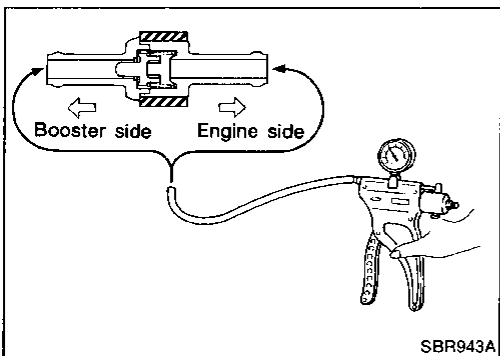

Connect to booster side	Vacuum should exist.
Connect to engine side	Vacuum should not exist.

## Pad Replacement

### WARNING:

Clean brake pads with a vacuum dust collector to minimize the hazard of airborne particles or other materials.

### CAUTION:

- When cylinder body is open, do not depress brake pedal because piston will pop out.
- Be careful not to damage piston boot or get oil on rotor. Always replace shims when replacing pads.
- If shims are rusted or show peeling of the rubber coat, replace them with new shims.
- It is not necessary to remove connecting bolt except for disassembly or replacement of caliper assembly. In this case, suspend cylinder body with wire so as not to stretch brake hose.

GI

MA

EM

LC

EC

FE

CL

MT

AT

FA

RA

BR

ST

RS

BT

HA

EL

IDX

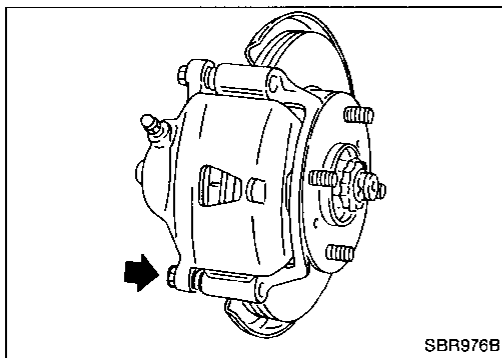

1. Remove master cylinder reservoir cap.
2. Remove pin bolt.
3. Open cylinder body upward. Then remove pad with retainers, inner and outer shims.

### Standard pad thickness:

11 mm (0.43 in)

### Pad wear limit:

2.0 mm (0.079 in)

Carefully monitor brake fluid level because brake fluid will return to reservoir when pushing back piston.

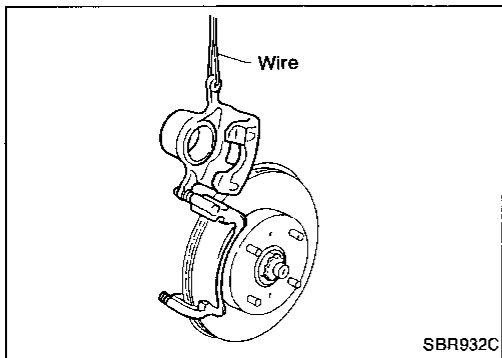

# FRONT DISC BRAKE

SEC. 440  
CL25VB

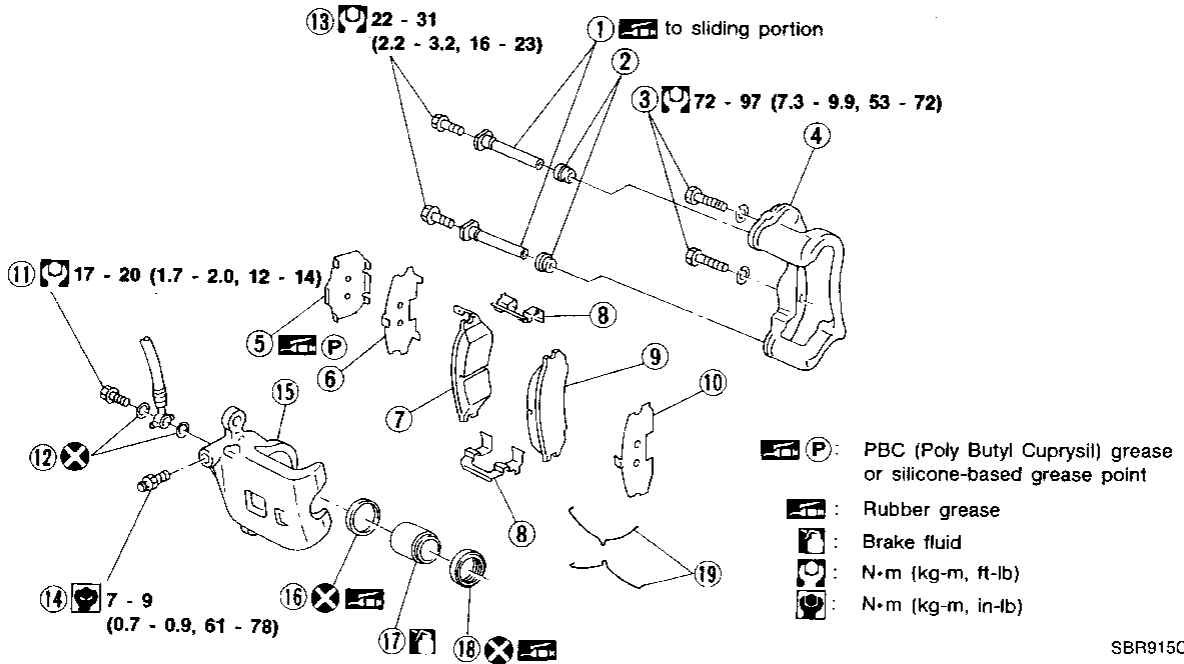

SBR915CB

- |                             |                   |                     |
|-----------------------------|-------------------|---------------------|
| ① Main pin                  | ⑧ Pad retainer    | ⑭ Bleed valve       |
| ② Pin boot                  | ⑨ Outer pad       | ⑮ Cylinder body     |
| ③ Torque member fixing bolt | ⑩ Outer shim      | ⑯ Piston seal       |
| ④ Torque member             | ⑪ Connecting bolt | ⑰ Piston            |
| ⑤ Shim cover                | ⑫ Copper washer   | ⑱ Piston boot       |
| ⑥ Inner shim                | ⑬ Main pin bolt   | ⑲ Pad return spring |
| ⑦ Inner pad                 |                   |                     |

## Removal

### WARNING:

Clean brake pads with a vacuum dust collector to minimize the hazard of airborne particles or other materials.

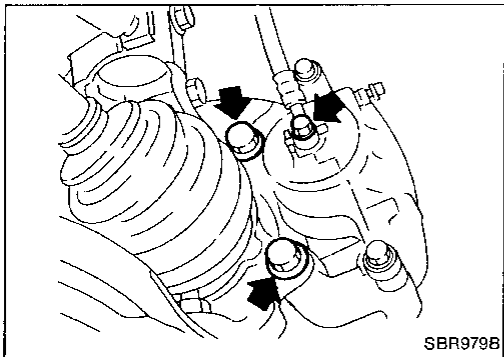

Remove torque member fixing bolts and connecting bolt.

It is not necessary to remove connecting bolt except for disassembly or replacement of caliper assembly. In this case, suspend caliper assembly with wire so as not to stretch brake hose.

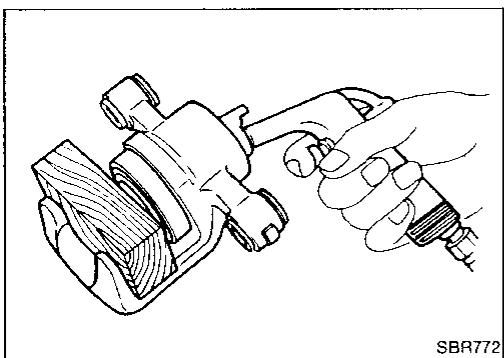

## Disassembly

### WARNING:

Do not place your fingers in front of piston.

### CAUTION:

Do not scratch or score cylinder wall.

1. Push out piston with piston boot with compressed air.
2. Remove piston seal with a suitable tool.

## Inspection — Caliper

### CYLINDER BODY

- Check inside surface of cylinder for score, rust, wear, damage or presence of foreign materials. If any of the above conditions are observed, replace cylinder body. GI
- Minor damage from rust or foreign materials may be eliminated by polishing surface with a fine emery paper. Replace cylinder body if necessary. MA

#### CAUTION:

Use brake fluid to clean. Never use mineral oil. EM

### PISTON

#### CAUTION:

Piston sliding surface is plated. Do not polish with emery paper even if rust or foreign materials are stuck to sliding surface. LC

Check piston for score, rust, wear, damage or presence of foreign materials. Replace if any of the above conditions are observed. EC

### SLIDE PIN, PIN BOLT AND PIN BOOT

Check for wear, cracks or other damage. Replace if any of the above conditions are observed. FE

## Inspection — Rotor

### RUBBING SURFACE

Check rotor for roughness, cracks or chips. CL

### RUNOUT

1. Secure rotor to wheel hub with at least two nuts (M12 x 1.25). MT
2. Check runout using a dial indicator. AT

Make sure that wheel bearing axial end play is within the specifications before measuring. Refer to "Front Wheel Bearing" in FA section. FA

#### Maximum runout:

0.08 mm (0.0031 in) RA

3. If the runout is out of specification, find minimum runout position as follows: BR
  - a. Remove nuts and rotor from wheel hub. ST
  - b. Shift the rotor one hole and secure rotor to wheel hub with nuts. RS
  - c. Measure runout. BT
  - d. Repeat steps a. to c. so that minimum runout position can be found. HA
4. If the runout is still out of specification, turn rotor with on-car brake lathe ("MAD, DL-8700", "AMMCO 700 and 705" or equivalent). EL IDX

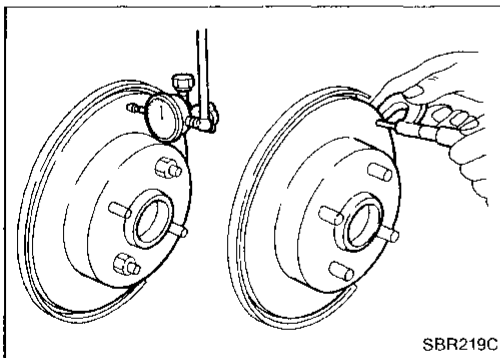

## FRONT DISC BRAKE

### Inspection — Rotor (Cont'd)

#### THICKNESS

Thickness variation (At least 8 positions):

Maximum 0.01 mm (0.0004 in)

If thickness variation exceeds the specification, turn rotor with on-car brake lathe.

**Rotor repair limit:**

20.0 mm (0.787 in)

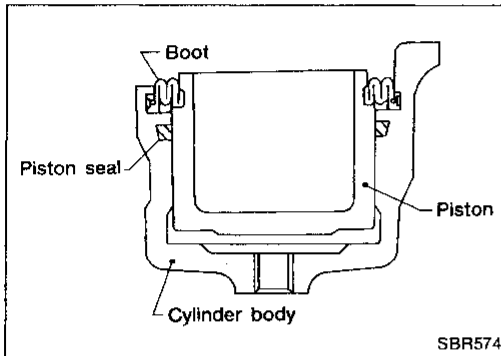

#### Assembly

1. Insert piston seal into groove on cylinder body.
2. With piston boot fitted to piston, insert piston boot into groove on cylinder body and install piston.
3. Properly secure piston boot.

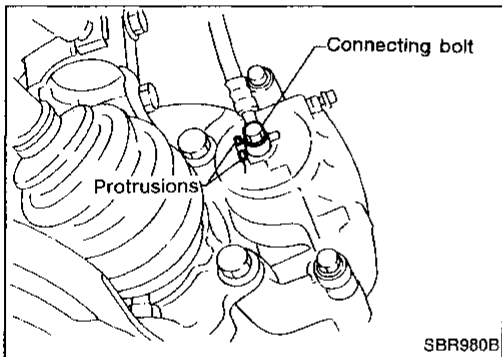

#### Installation

##### CAUTION:

- Refill with new brake fluid "DOT 3".
  - Never reuse drained brake fluid.
1. Install brake hose to caliper securely.
  2. Install all parts and secure all bolts.
  3. Bleed air. Refer to "Bleeding Brake System" (BR-5).

# REAR DISC BRAKE

## Pad Replacement

### WARNING:

Clean brake pads with a vacuum dust collector to minimize the hazard of airborne particles or other materials.

### CAUTION:

- When cylinder body is open, do not depress brake pedal because piston will pop out.
- Be careful not to damage piston boot or get oil on rotor. Always replace shims in replacing pads.
- If shims are rusted or show peeling of rubber coat, replace them with new shims.
- It is not necessary to remove connecting bolt except for disassembly or replacement of caliper assembly. In this case, suspend cylinder body with wire so as not to stretch brake hose.

GI

MA

EM

LC

EC

FE

CL

MT

AT

FA

RA

BR

ST

RS

BT

HA

EL

IDX

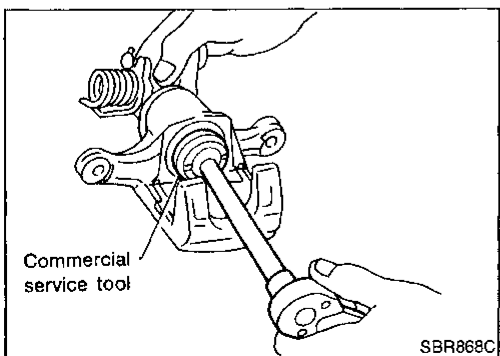
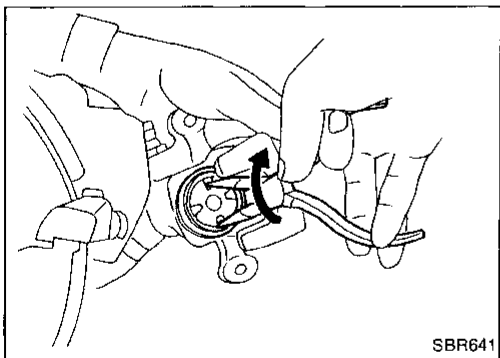
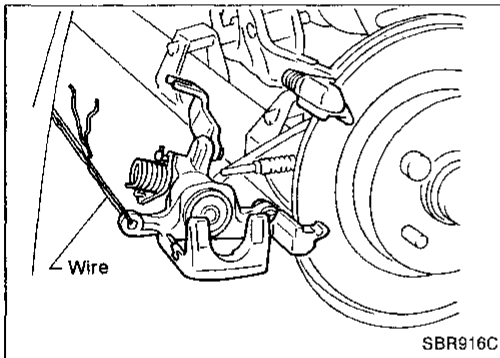
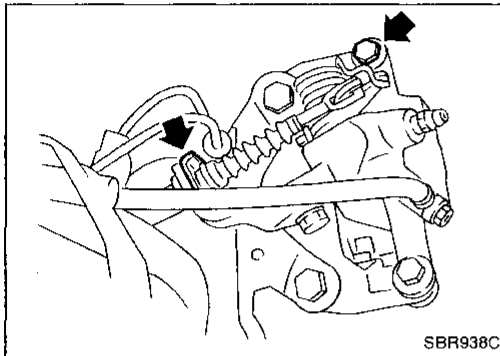

1. Remove master cylinder reservoir cap.
2. Remove brake cable mounting bolt and lock spring.
3. Release parking brake control lever, then disconnect cable from the caliper.
4. Remove upper pin bolt.
5. Open cylinder body downward. Then remove pad retainers, and inner and outer shims.

### Standard pad thickness:

10 mm (0.39 in)

### Pad wear limit:

1.5 mm (0.059 in)

6. When installing new pads, push piston into cylinder body by gently turning piston clockwise, as shown.

Carefully monitor brake fluid level because brake fluid will return to reservoir when pushing back piston.

# REAR DISC BRAKE

## SEC. 441

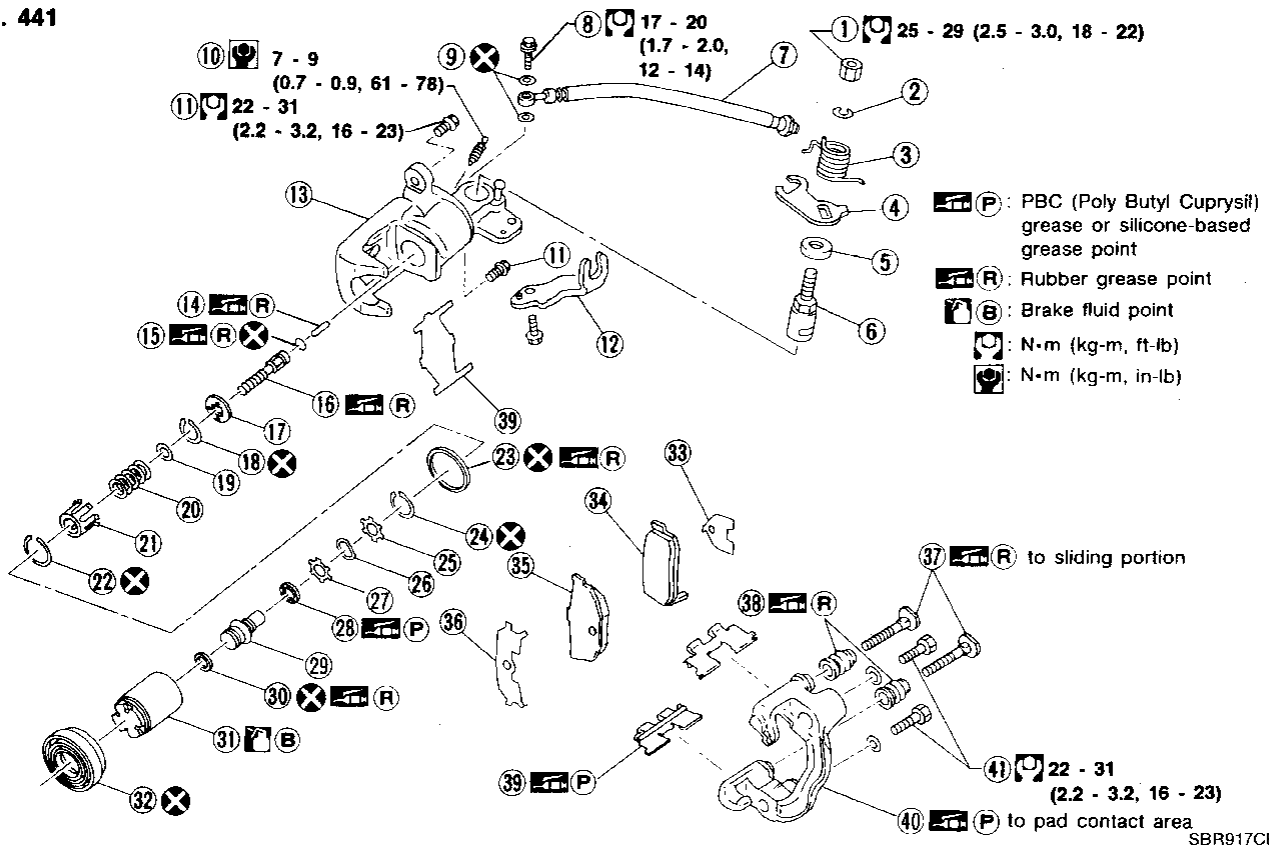

SBR917CB

- |                          |                |                             |
|--------------------------|----------------|-----------------------------|
| ① Nut                    | ⑮ O-ring       | ⑳ Adjusting nut             |
| ② Washer                 | ⑯ Push rod     | ㉑ Cup                       |
| ③ Return spring          | ⑰ Key plate    | ㉒ Piston                    |
| ④ Parking brake lever    | ⑱ Ring C       | ㉓ Dust seal                 |
| ⑤ Cam boot               | ⑲ Seat         | ㉔ Inner shim                |
| ⑥ Cam                    | ⑳ Spring       | ㉕ Inner pad                 |
| ⑦ Brake hose             | ㉑ Spring cover | ㉖ Outer pad                 |
| ⑧ Connecting bolt        | ㉒ Ring B       | ㉗ Outer shim                |
| ⑨ Copper washer          | ㉓ Piston seal  | ㉘ Pin                       |
| ⑩ Bleed screw            | ㉔ Ring A       | ㉙ Pin boot                  |
| ⑪ Pin bolt               | ㉕ Spacer       | ㉚ Pad retainer              |
| ⑫ Cable mounting bracket | ㉖ Wave washer  | ㉛ Torque member             |
| ⑬ Cylinder               | ㉗ Spacer       | ㉜ Torque member fixing bolt |
| ⑭ Strut                  | ㉘ Ball bearing |                             |



# REAR DISC BRAKE

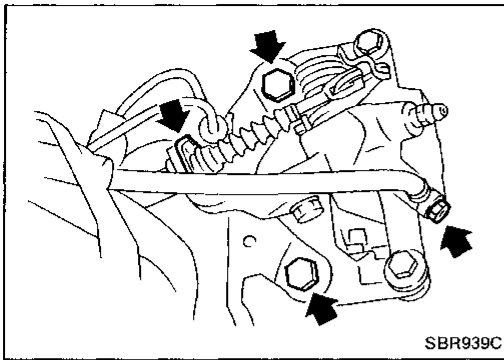

## Removal

### WARNING:

Clean brake pads with a vacuum dust collector to minimize the hazard of airborne particles or other materials.

1. Remove brake cable mounting bolt and lock spring.
2. Release parking brake control lever, then disconnect cable from the caliper.
3. Remove torque member fixing bolts and connecting bolt.

It is not necessary to remove connecting bolt except for disassembly or replacement of caliper assembly. In this case, suspend caliper assembly with wire so as not to stretch brake hose.

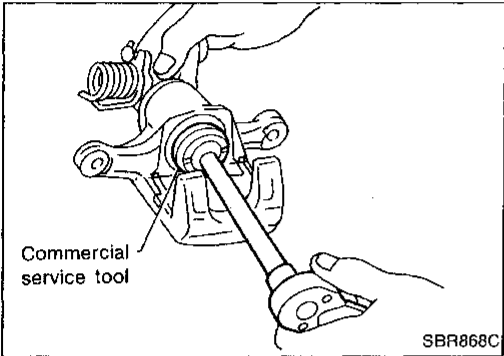

## Disassembly

1. Remove piston by turning it counterclockwise with suitable commercial service tool or long nose pliers.

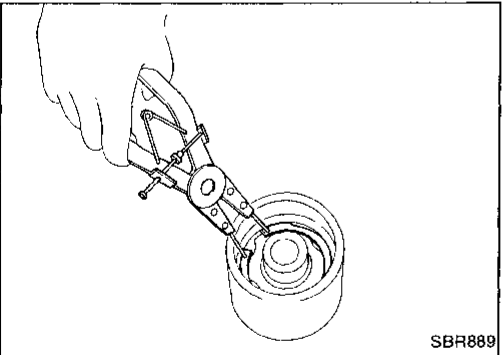
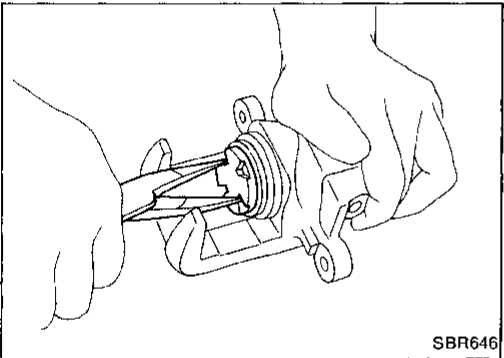

2. Pry off ring A from piston with suitable pliers and remove adjusting nut.

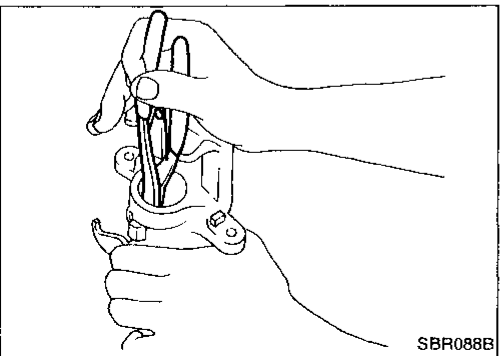

3. Disassemble cylinder body.
  - a. Pry off ring B with suitable pliers, then remove spring cover, spring and seat.
  - b. Pry off ring C, then remove key plate, push rod and rod.

GI

MA

EM

LC

EC

FE

CL

MT

AT

FA

RA

BR

ST

RS

BT

HA

EL

IDX

## REAR DISC BRAKE

### Disassembly (Cont'd)

c. Remove piston seal.

**Be careful not to damage cylinder body.**

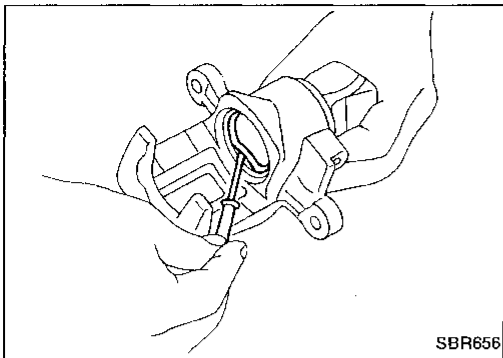

SBR656

4. Remove return spring, nut and lever.

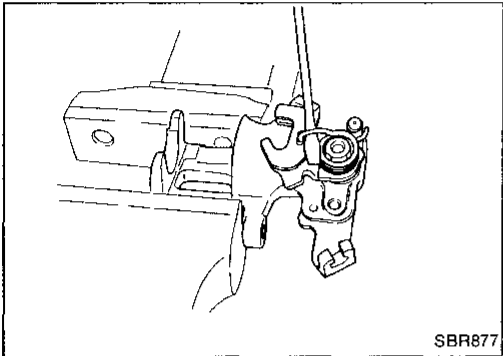

SBR877

### Inspection — Caliper

#### CAUTION:

**Use brake fluid to clean cylinder. Never use mineral oil.**

#### CYLINDER BODY

- Check inside surface of cylinder for score, rust, wear, damage or presence of foreign materials. If any of the above conditions are observed, replace cylinder body.
- Minor damage from rust or foreign materials may be eliminated by polishing surface with a fine emery paper. Replace cylinder body if necessary.

#### TORQUE MEMBER

Check for wear, cracks or other damage. Replace if necessary.

#### PISTON

##### CAUTION:

**Piston sliding surface is plated. Do not polish with emery paper even if rust or foreign matter is stuck to sliding surface.**

Check piston for score, rust, wear, damage or presence of foreign materials.

Replace if any of the above conditions are observed.

#### PIN AND PIN BOOT

Check for wear, cracks or other damage.

Replace if any of the above conditions are observed.

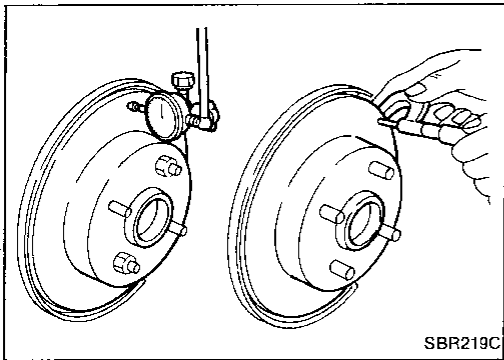

## Inspection — Rotor

### RUBBING SURFACE

Check rotor for roughness, cracks or chips.

### RUNOUT

1. Secure rotor to wheel hub with two nuts (M12 x 1.25).
2. Check runout using a dial indicator.

**Make sure that axial end play is within the specifications before measuring. Refer to "Rear Wheel Bearing" in RA section.**

3. Change relative positions of rotor and wheel hub so that runout is minimized.

**Maximum runout:**  
0.15 mm (0.0059 in)

### THICKNESS

**Rotor repair limit:**  
**Standard thickness**  
9 mm (0.35 in)  
**Minimum thickness**  
8 mm (0.31 in)

**Thickness variation (At least 8 portions)**  
Maximum 0.02 mm (0.0008 in)

## Assembly

1. Install cup in the specified direction.

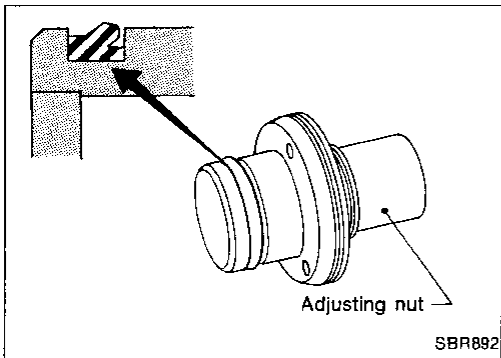

2. Fit push rod into square hole in key plate. Also match convex portion of key plate with concave portion of cylinder.

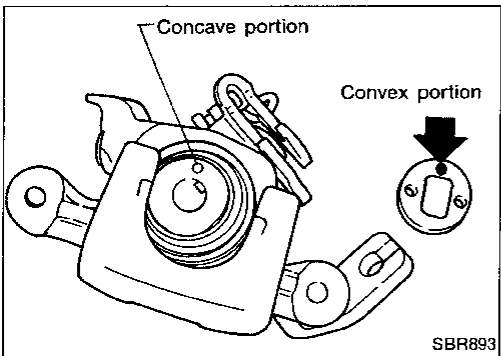

3. Install ring C with a suitable tool.

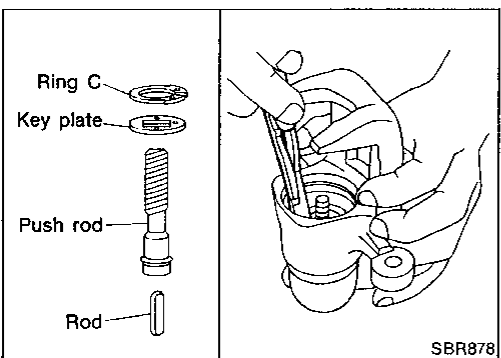

GI

MA

EM

LC

EC

FE

CL

MT

AT

FA

RA

BR

ST

RS

BT

HA

EL

IDX

## REAR DISC BRAKE

### Assembly (Cont'd)

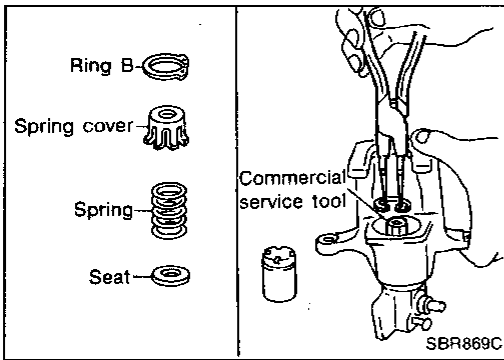

4. Install seat, spring, spring cover and ring B with suitable press and drift.

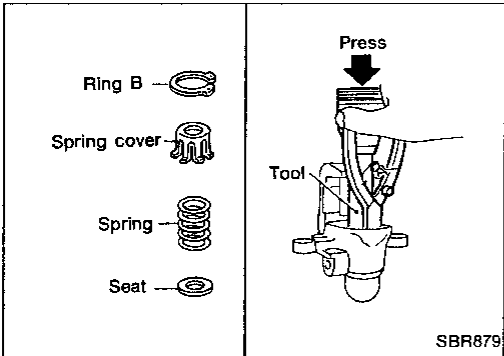

5. Install cup, adjuster, bearing, spacers, washers and ring A with a suitable tool.

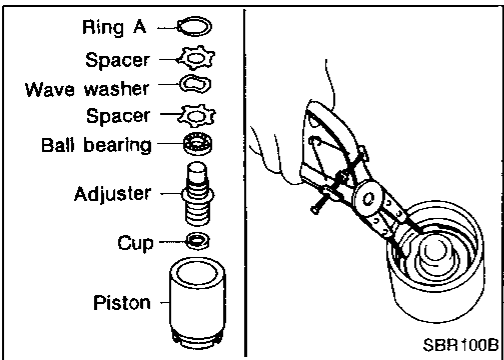

6. Fit lever and tighten nut.
7. Fit return spring in the order shown.

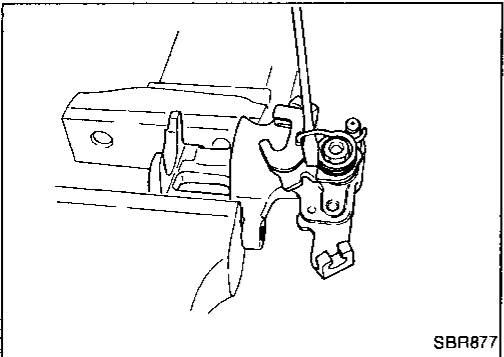

### Installation

#### CAUTION:

- Refill with new brake fluid "DOT 3".
  - Never reuse drained brake fluid.
1. Install brake hose to caliper securely.
  2. Install all parts and secure all bolts.
  3. Bleed air. Refer to "Bleeding Brake System" (BR-5).

# PARKING BRAKE CONTROL

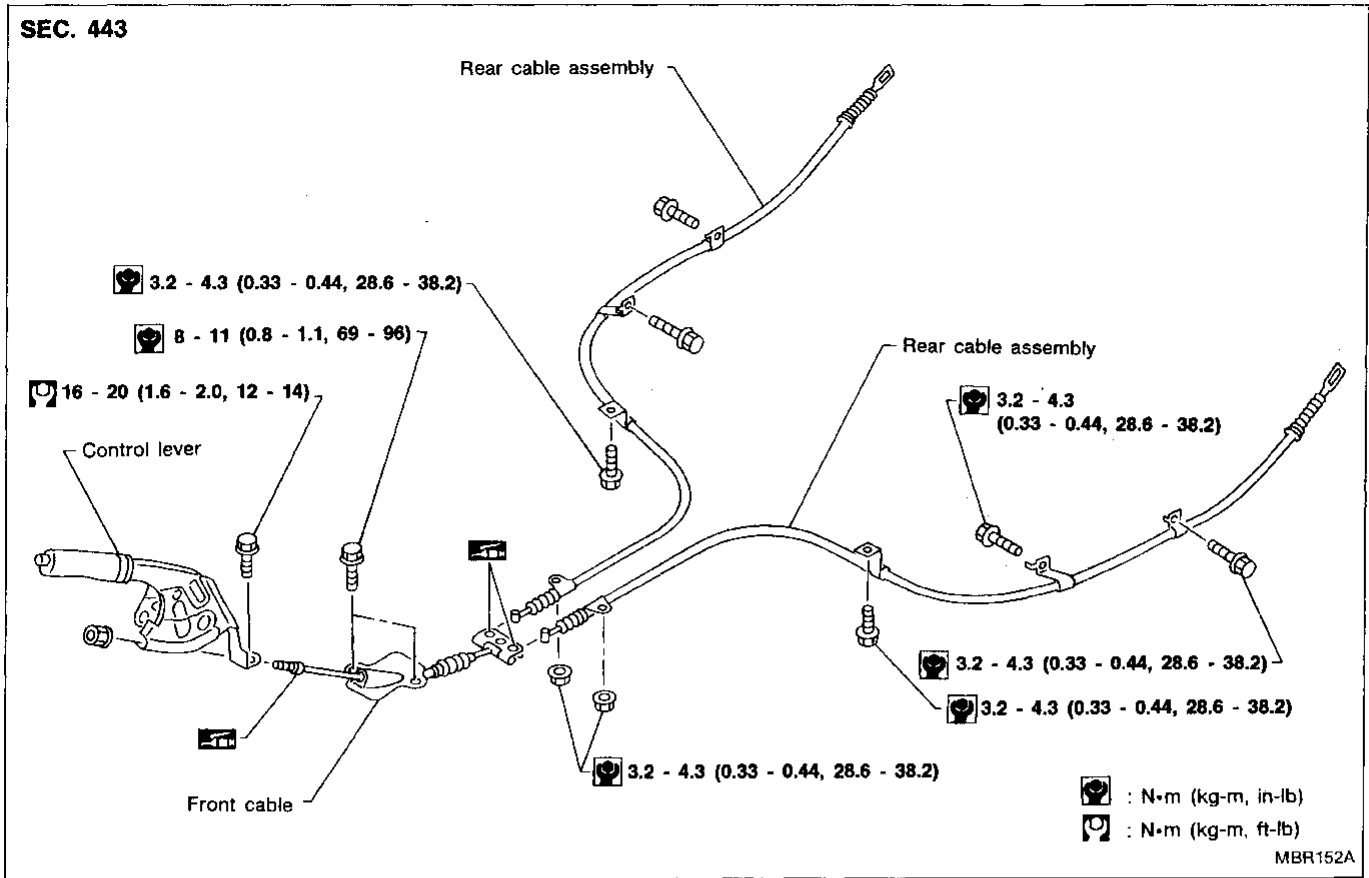

GI  
MA  
EM  
LC  
EC  
FE  
CL  
MT  
AT  
FA  
RA  
BR  
ST  
RS  
BT  
HA  
EL  
IDX

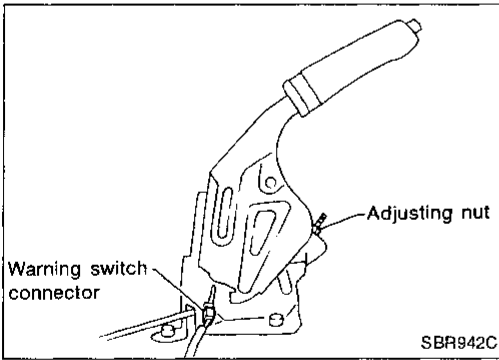

## Removal and Installation

1. To remove parking brake cable, first remove center console.
2. Disconnect warning switch connector.
3. Remove bolts, slacken off and remove adjusting nut.
4. Remove parking brake cable lock plate.

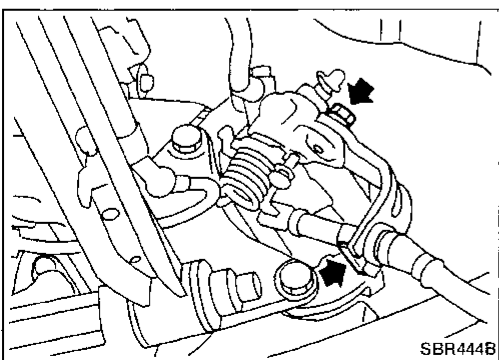

# PARKING BRAKE CONTROL

## Inspection

1. Check control lever for wear or other damage. Replace if necessary.
2. Check wires for discontinuity or deterioration. Replace if necessary.
3. Check warning lamp and switch. Replace if necessary.
4. Check parts at each connecting portion and, if found deformed or damaged, replace.

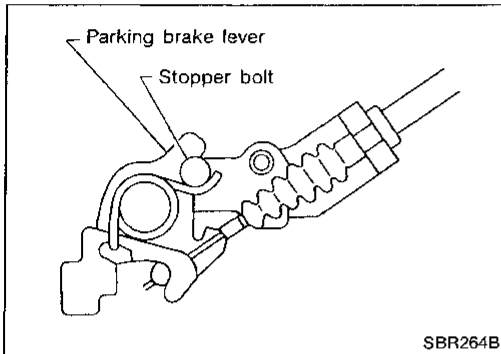

## Adjustment

### Pay attention to the following points after adjustment.

- a. There is no drag when control lever is being released.
- b. Parking brake lever returns to stopper bolt when control lever for rear disc brake models is released.

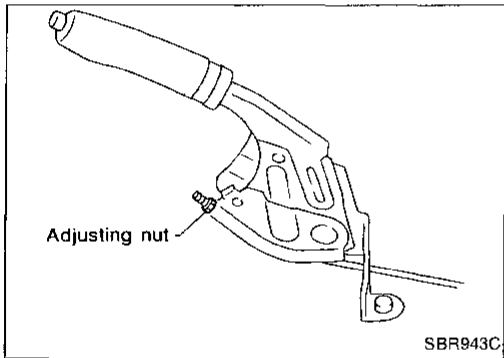

1. Loosen parking brake cable.
2. Depress brake pedal fully more than 5 times.
3. Adjust control lever by turning adjusting nut.
4. Pull control lever with specified amount of force. Check lever stroke and ensure smooth operation.  
**Number of notches : 10 - 11 [196 N (20 kg, 44 lb)]**
5. Bend warning lamp switchplate. Warning lamp should come on when lever is pulled "A" notches. It should go off when the lever is fully released.  
**Number of "A" notches : 1**

# ANTI-LOCK BRAKE SYSTEM

## Purpose

The ABS consists of electronic and hydraulic components. It allows for control of braking force so that locking of the wheels can be avoided.

The ABS:

- 1) Ensures proper tracking performance through steering wheel operation.
- 2) Enables obstacles to be avoided through steering wheel operation.
- 3) Ensures vehicle stability by preventing flat spins.

## Operation

- When the vehicle speed is less than 10 km/h (6 MPH) this system does not work.
- The Anti-Lock Brake System (ABS) has self-test capabilities. The system turns on the ABS warning lamp for 1 second after turning the ignition switch ON. The system performs another test the first time the vehicle reaches 6 km/h (4 MPH). A mechanical noise may be heard as the ABS performs a self-test. This is a normal part of the self-test feature. If a malfunction is found during this check, the ABS warning lamp will come on.
- During ABS operation, a mechanical noise may be heard. This is a normal condition.

## ABS Hydraulic Circuit

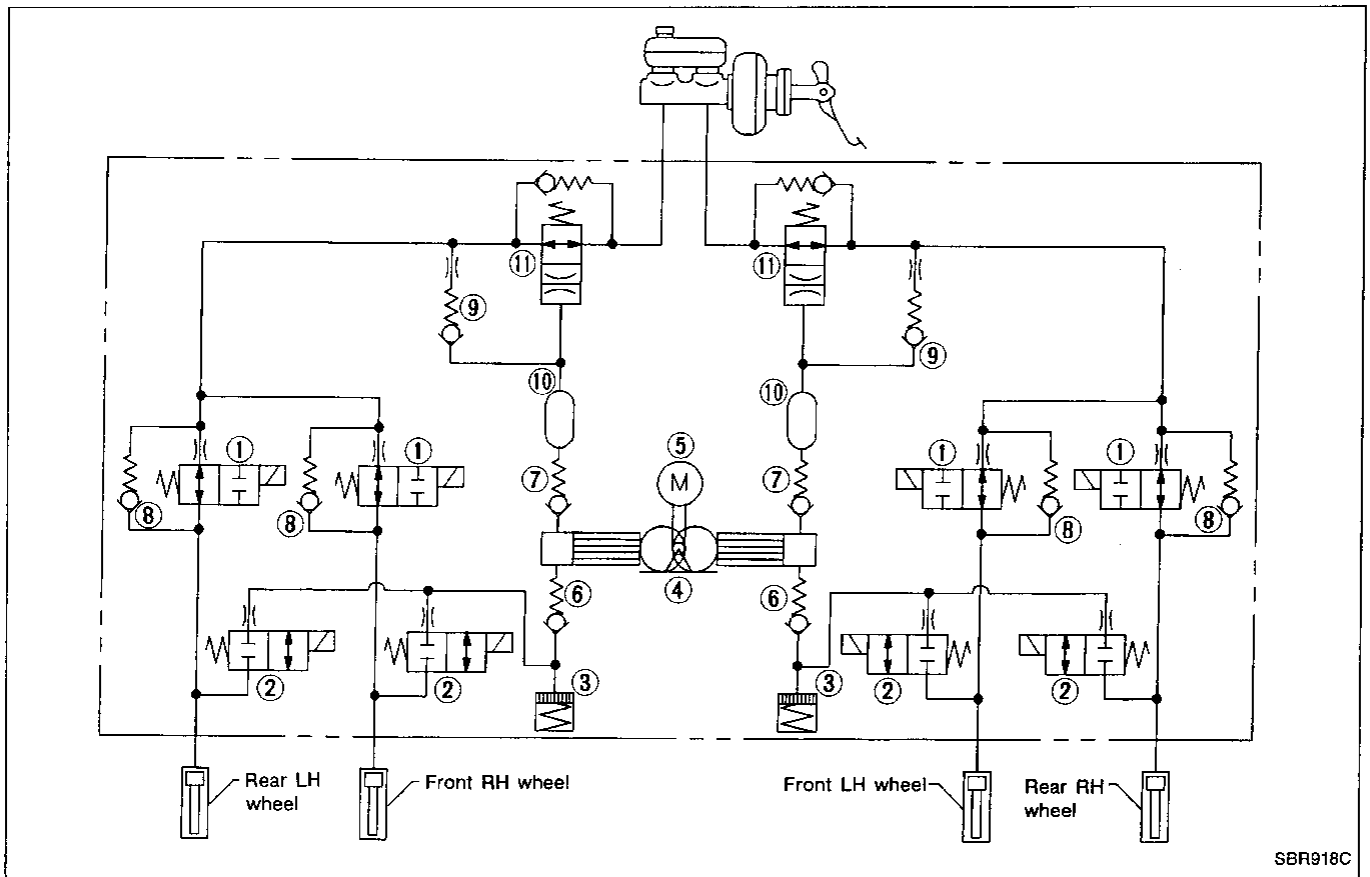

- |                         |                      |                   |
|-------------------------|----------------------|-------------------|
| ① Inlet solenoid valve  | ⑤ Motor              | ⑨ Check valve     |
| ② Outlet solenoid valve | ⑥ Inlet valve        | ⑩ Damper          |
| ③ Reservoir             | ⑦ Outlet valve       | ⑪ Gradient switch |
| ④ Pump                  | ⑧ Bypass check valve |                   |

## System Components

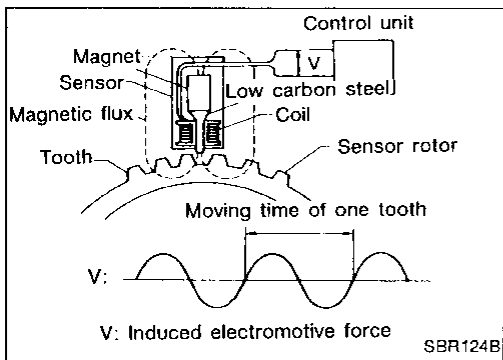
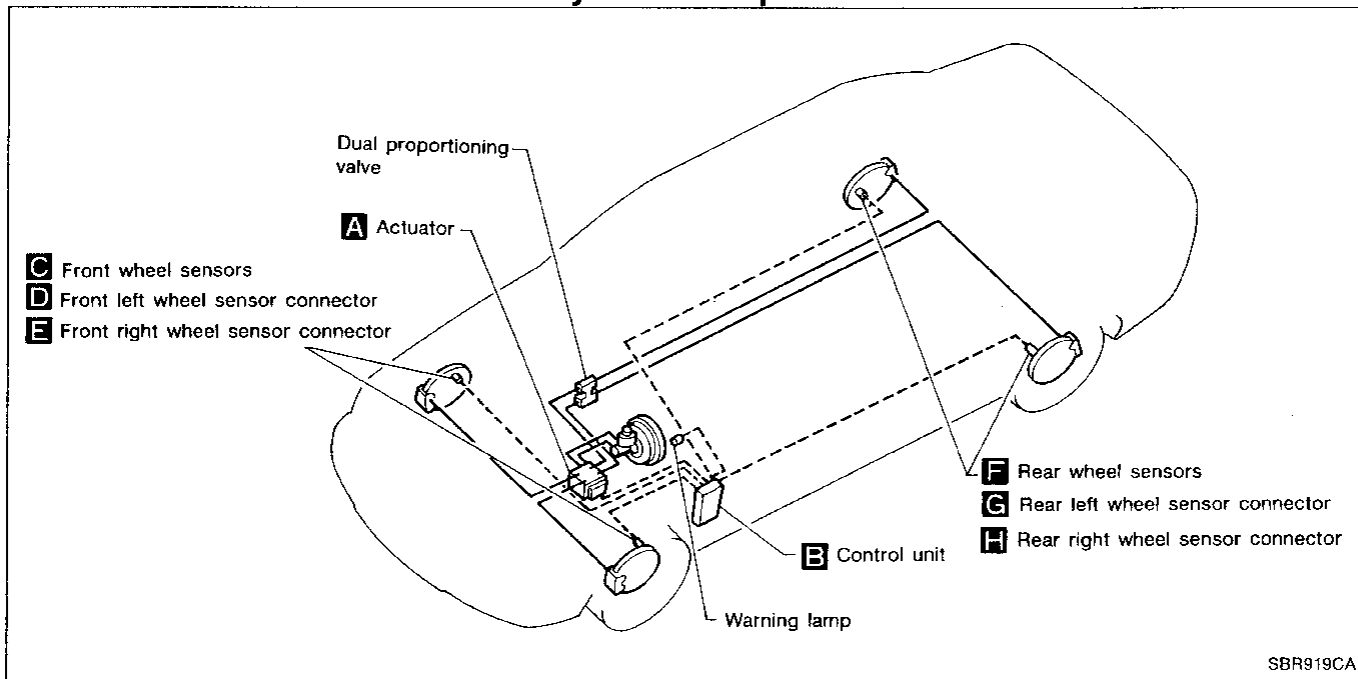

## System Description

### SENSOR

The sensor unit consists of a gear-shaped sensor rotor and a sensor element. The element contains a bar magnet around which a coil is wound. The sensor is installed on the back side of the brake rotor. Sine-wave current is generated by the sensor as the wheel rotates. The frequency and voltage increase(s) as the rotating speed increases.

### CONTROL UNIT

The control unit computes the wheel rotating speed by the signal current sent from the sensor. Then it supplies a DC current to the actuator solenoid valve. It also controls ON-OFF operation of the valve relay and motor relay. If any electrical malfunction should be detected in the system, the warning lamp is turned on. In this condition, the ABS will be deactivated, and the vehicle's brake system reverts to normal operation.

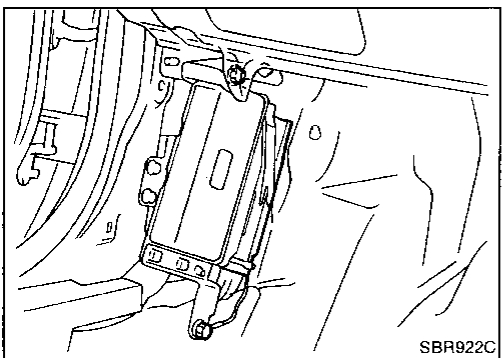
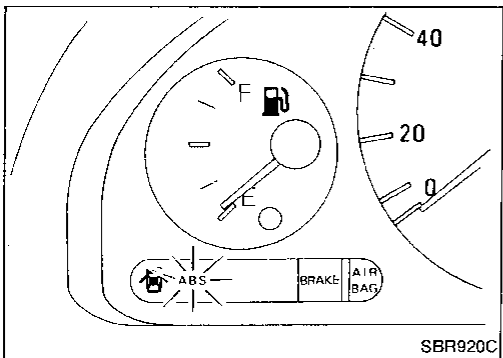



## Removal and Installation

### CAUTION:

Be careful not to damage sensor edge and sensor rotor teeth. When removing the front or rear wheel hub assembly, first remove the ABS wheel sensor from the assembly. Failure to do so may result in damage to the sensor wires making the sensor inoperative.

### WHEEL SENSORS

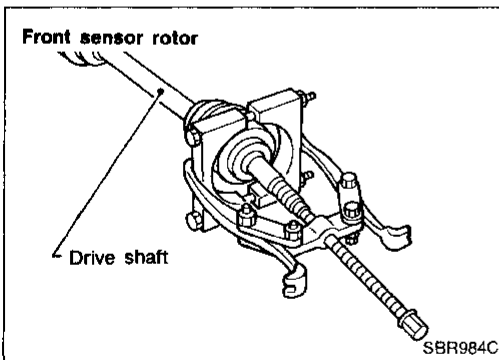
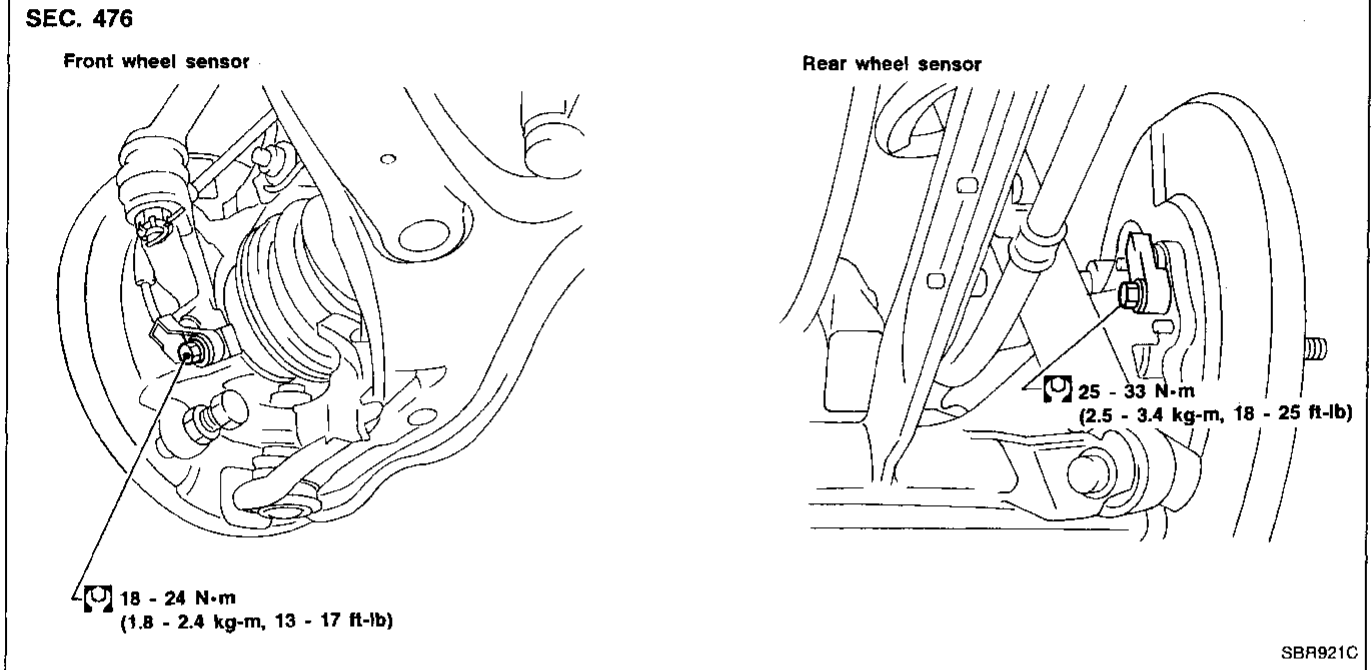

### SENSOR ROTOR

#### Removal

1. Remove the drive shaft and rear wheel hub. Refer to "Drive Shaft" in FA section and "Wheel Hub" in RA section.
2. Remove the sensor rotor using suitable puller, drift and bearing replacer.

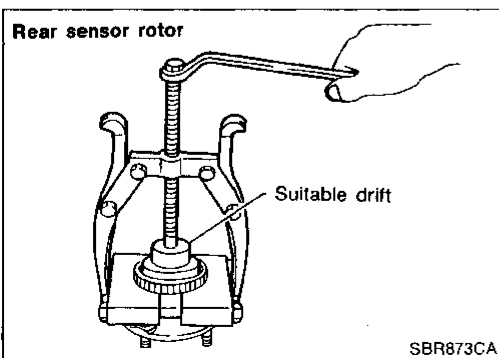

# ANTI-LOCK BRAKE SYSTEM

## Removal and Installation (Cont'd)

### Installation

Install the sensor rotor. For front sensor rotor, use hammer and wooden block. For rear sensor rotor, use suitable drift and press.

- Always replace sensor rotor with new one.

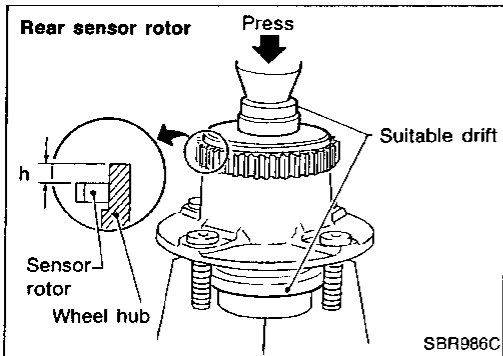
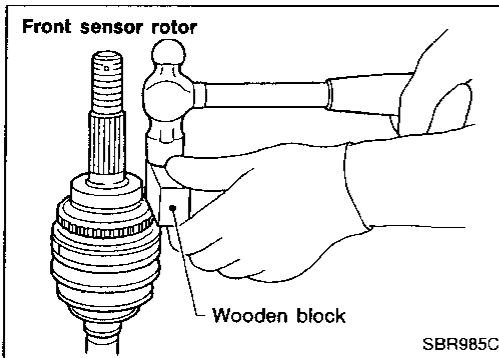

- Pay attention to the dimension of rear sensor rotor as show in figure.

h: 12.5 - 13.5 mm (0.492 - 0.531 in)

### CONTROL UNIT

Location: Driver side dash side lower.

- Make sure that the sensor shield ground cable is secured with lower mounting bolt.

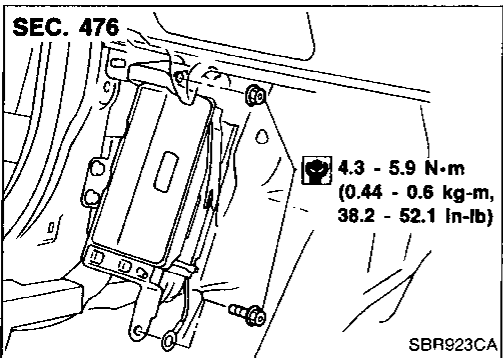

### ACTUATOR

#### Removal

1. Disconnect battery cable.
2. Drain brake fluid. Refer to "Changing Brake Fluid" (BR-5).
3. Apply different colored paint to each pipe connector and actuator to prevent incorrect connection.
4. Disconnect harness connectors, brake pipes and remove fixing nuts and actuator ground cable.

#### Installation

##### CAUTION:

- Make sure that the rubber bushing is attached to actuator's mounting portion.
- Make sure that the drain hose is firmly installed on the actuator.
- After installation, refill brake fluid. Then bleed air. Refer to "Bleeding Brake System" (BR-5).

1. Temporarily install actuator on the bracket.
2. Tighten actuator ground cable.
3. Connect brake pipes temporarily.
4. Tighten fixing nuts.
5. Tighten brake pipes.
6. Connect harness connectors and battery cable.

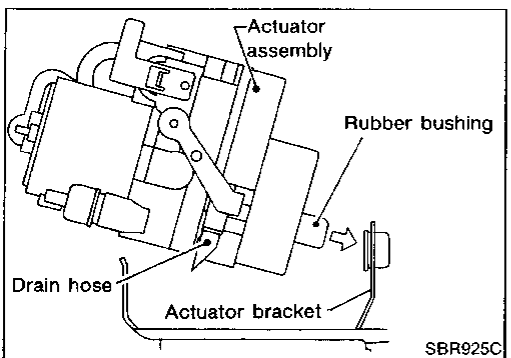
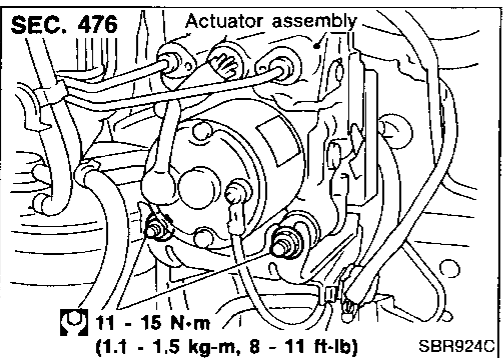

# ANTI-LOCK BRAKE SYSTEM

## Wiring Diagram — ABS —

BR-ABS-01

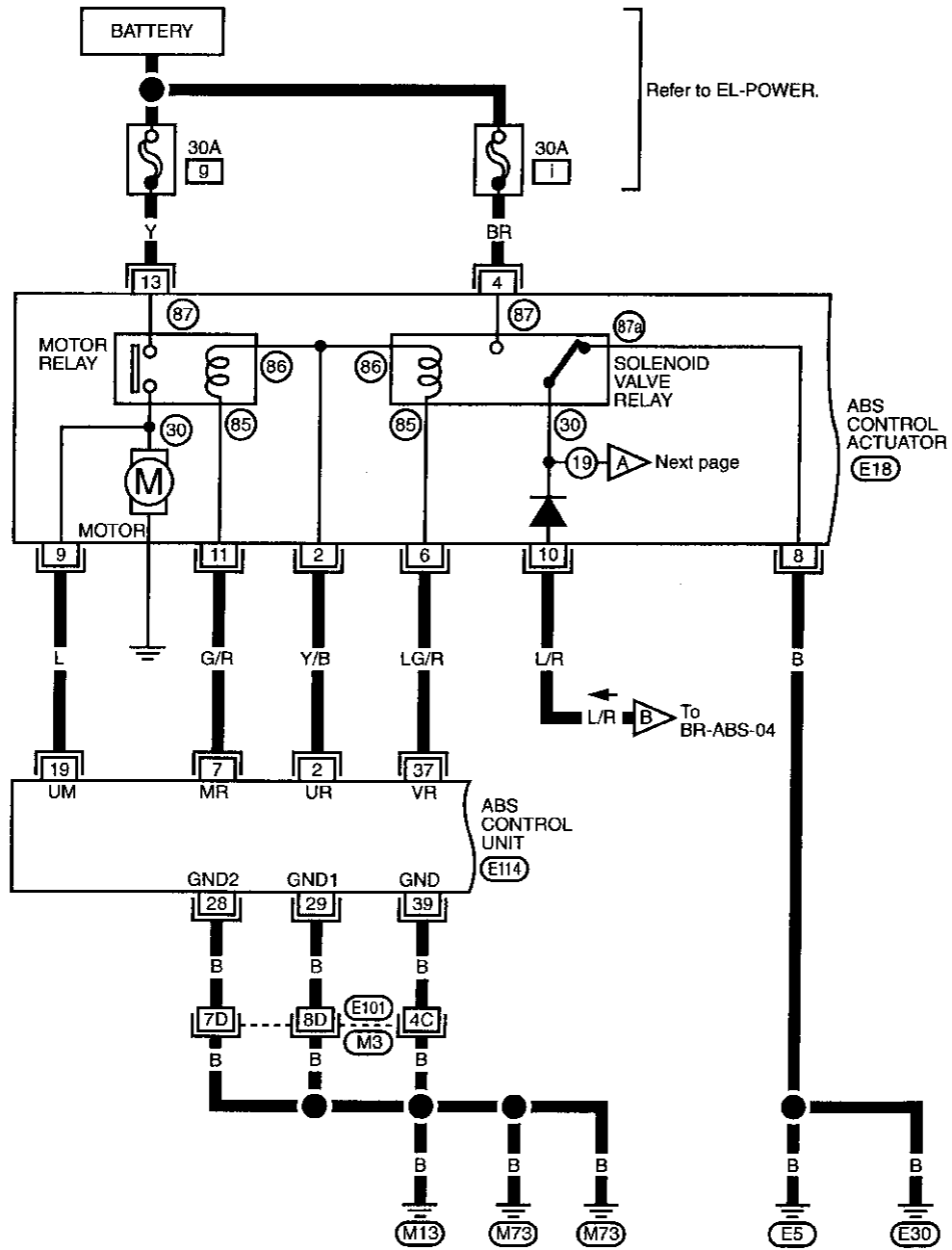

GI  
MA  
EM  
LC  
EC  
FE  
CL  
MT  
AT  
FA  
RA  
BR  
ST  
RS  
BT  
HA  
EL  
IDX

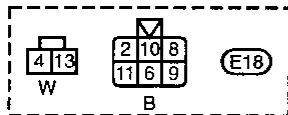

Refer to last page (Foldout page).

(M3) . (E101)

1	2	3	4	5	6	7	8	9	10	11	12	13	14	15	16	17	18	19	20	21	22	23	24	25	26	27	28
29	30	31	32	33	34	35	36	37	38	39	40	41	42	43	44	45	46	47	48	49	50	51	52	53	54	55	
56	57	58	59	60	61	62	63	64	65	66	67	68	69	70	71	72	73	74	75	76	77	78	79	80	81	82	83

(E114)



# ANTI-LOCK BRAKE SYSTEM

## Wiring Diagram — ABS — (Cont'd)

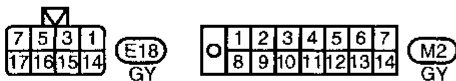
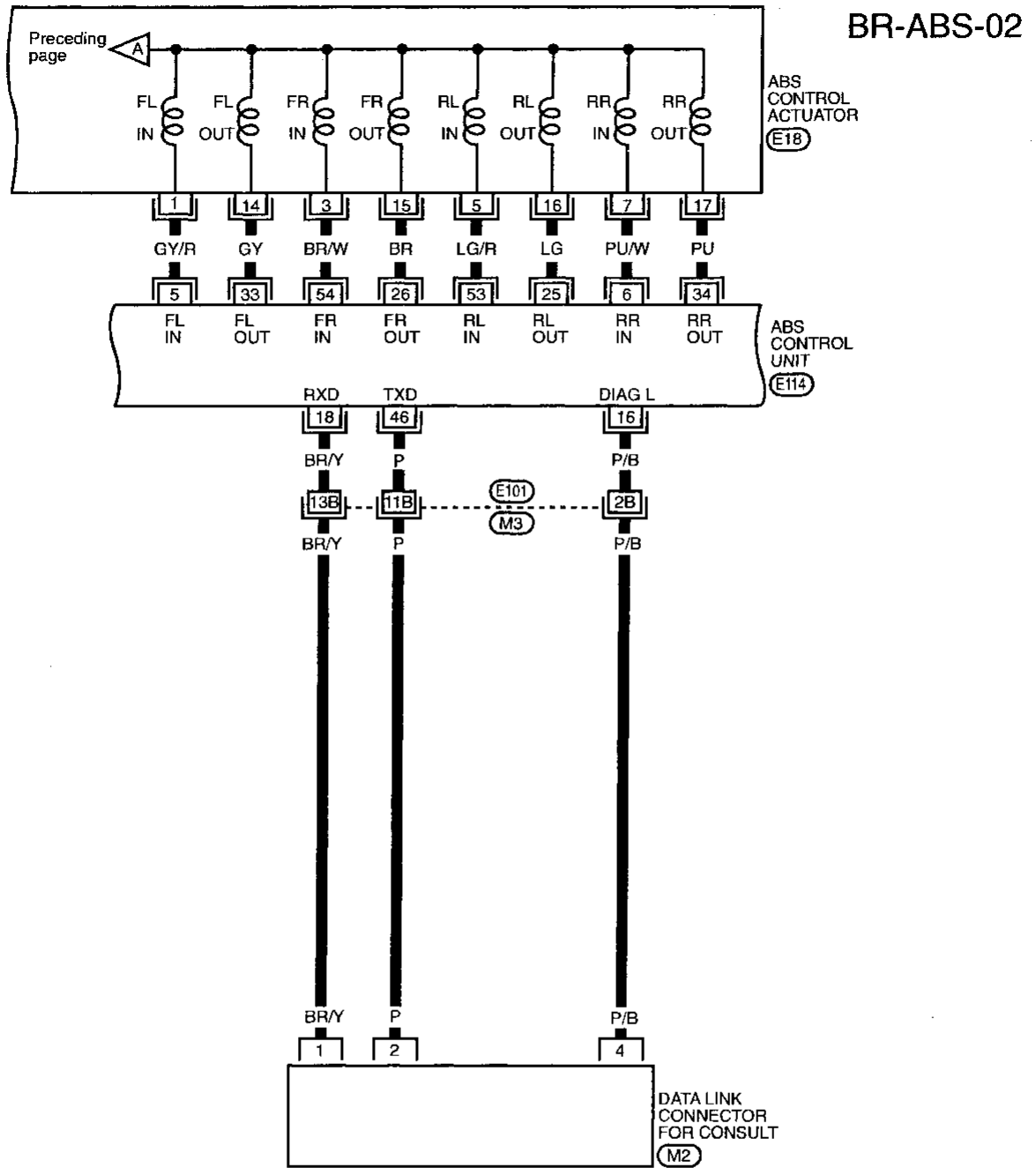

Refer to last page (Foldout page).

(M3) (E101)



(E114)



# ANTI-LOCK BRAKE SYSTEM

## Wiring Diagram — ABS — (Cont'd)

BR-ABS-03

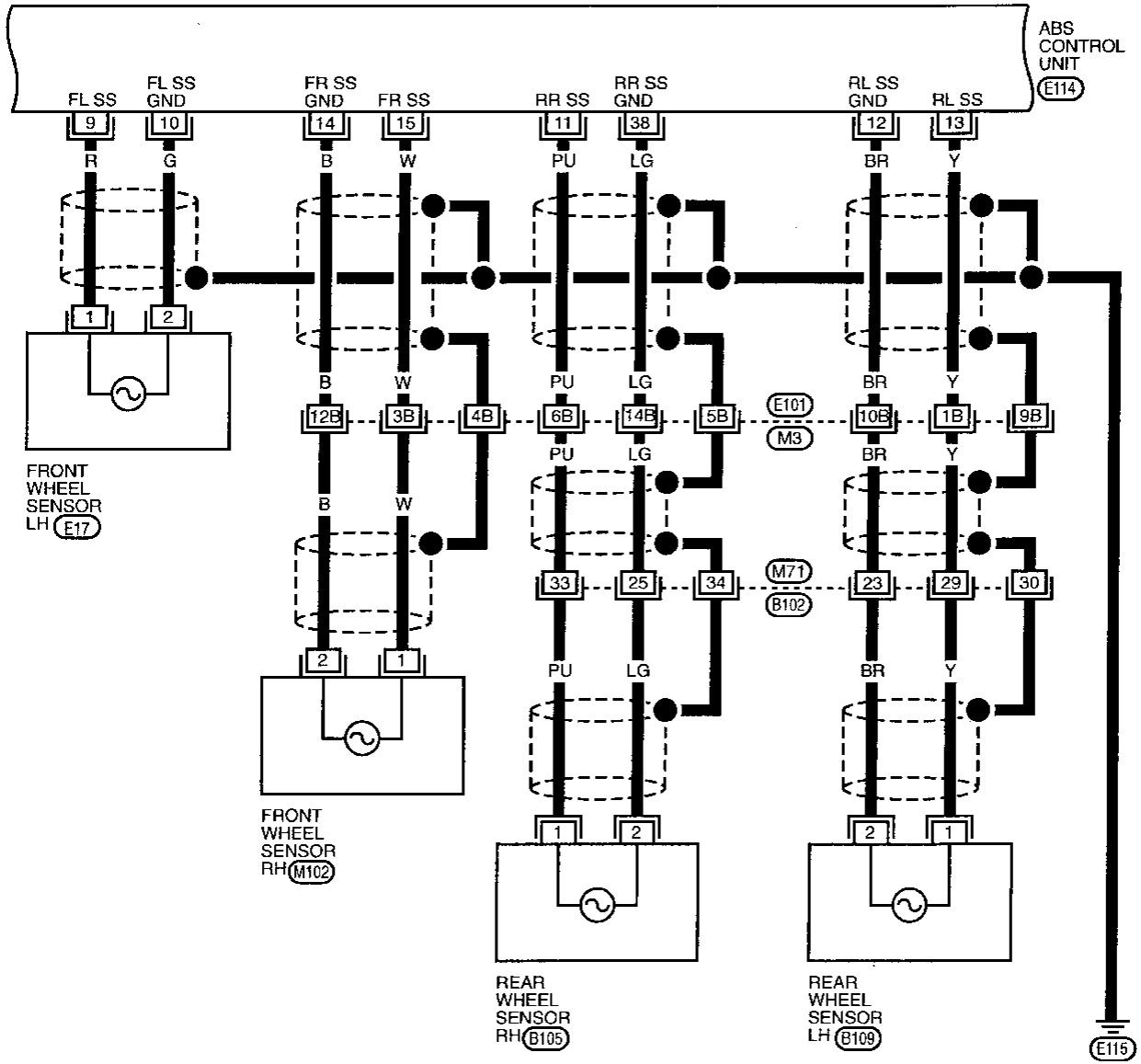

GI  
MA  
EM  
LC  
EC  
FE  
CL  
MT  
AT  
FA  
RA  
BR  
ST  
RS  
BT  
HA  
EL  
IDX

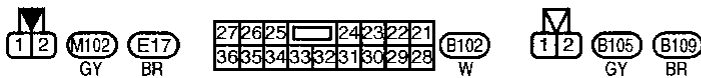

Refer to last page (Foldout page).

(M3), (E101)

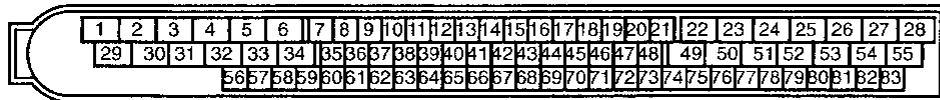

# ANTI-LOCK BRAKE SYSTEM

## Wiring Diagram — ABS — (Cont'd)

BR-ABS-04

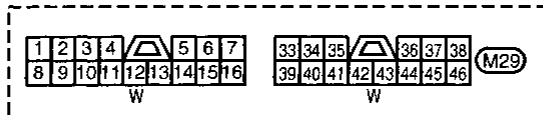
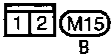
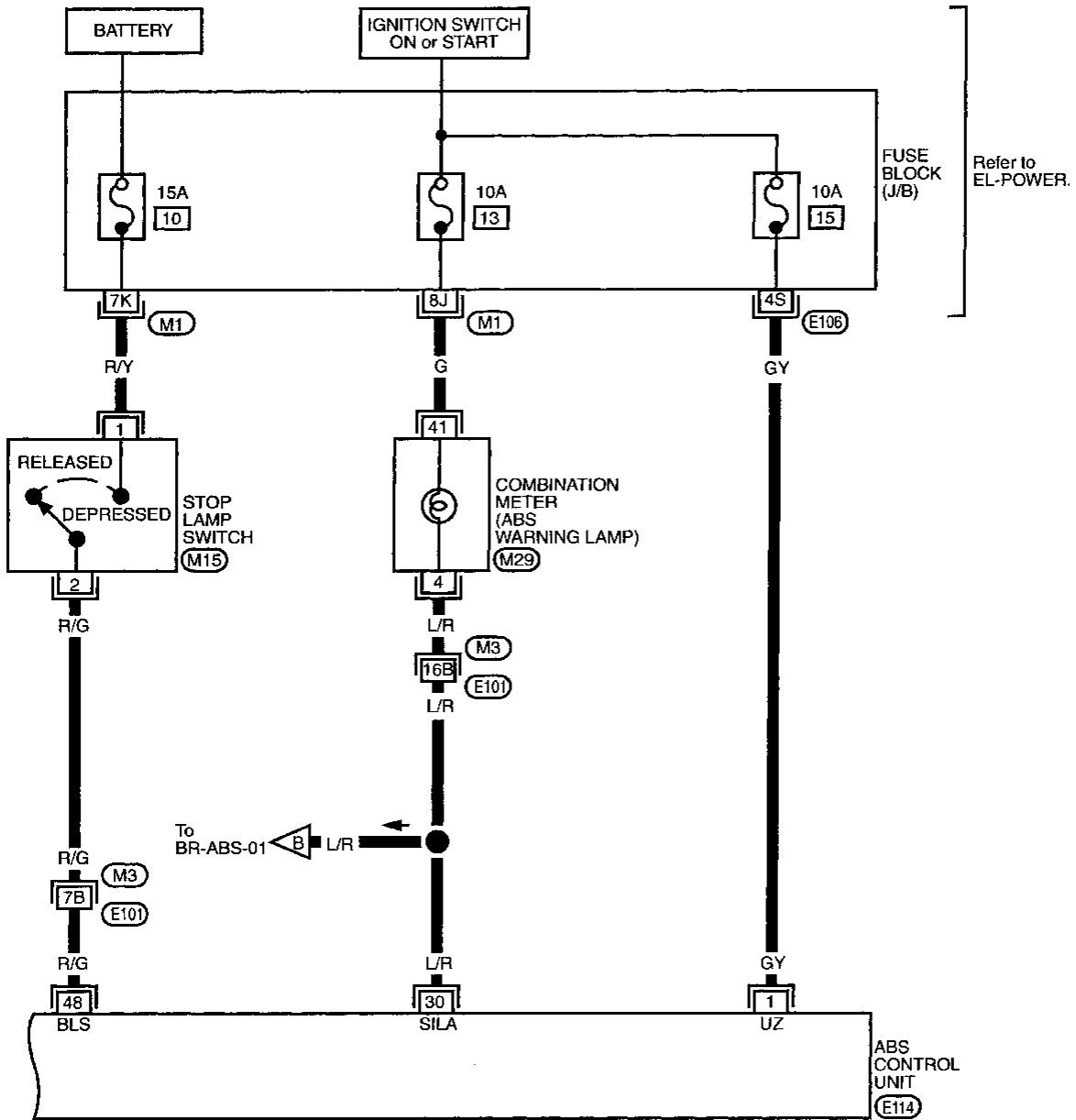

Refer to last page (Foldout page).

(M1), (M3), (E101)



## Contents

How to Perform Trouble Diagnoses for Quick and Accurate Repair .....	BR-31
Self-diagnosis .....	BR-32
<b>CONSULT</b> .....	BR-35
<b>CONSULT Inspection Procedure</b> .....	BR-36
<b>Component Parts and Harness Connector Location</b> .....	BR-41
<b>Preliminary Check</b> .....	BR-42
<b>Ground Circuit Check</b> .....	BR-43
<b>Circuit Diagram for Quick Pinpoint Check</b> .....	BR-44
<b>Diagnostic Procedure 1 Warning lamp does not work</b> .....	BR-45
<b>Diagnostic Procedure 2 Warning lamp stays on</b> .....	BR-46
<b>Diagnostic Procedure 3 Actuator solenoid valve</b> .....	BR-49
<b>Diagnostic Procedure 4 Wheel sensor or rotor</b> .....	BR-51
<b>Diagnostic Procedure 5 Motor relay or motor</b> .....	BR-53
<b>Diagnostic Procedure 6 Solenoid valve relay</b> .....	BR-56
<b>Diagnostic Procedure 7 Power supply</b> .....	BR-58
<b>Diagnostic Procedure 8 Control unit</b> .....	BR-58
<b>Diagnostic Procedure 9 Pedal vibration and noise</b> .....	BR-59
<b>Diagnostic Procedure 10 Long stopping distance</b> .....	BR-60
<b>Diagnostic Procedure 11 Unexpected pedal action</b> .....	BR-60
<b>Diagnostic Procedure 12 ABS does not work</b> .....	BR-61
<b>Diagnostic Procedure 13 ABS works frequently</b> .....	BR-61
<b>Electrical Component Inspection</b> .....	BR-62

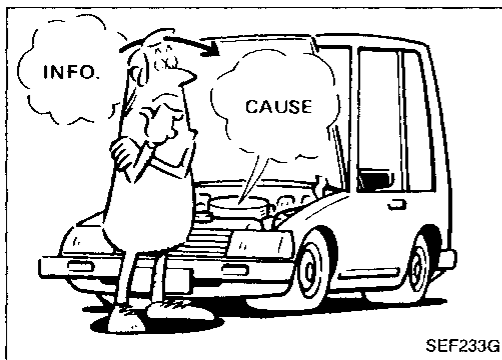

SEF233G

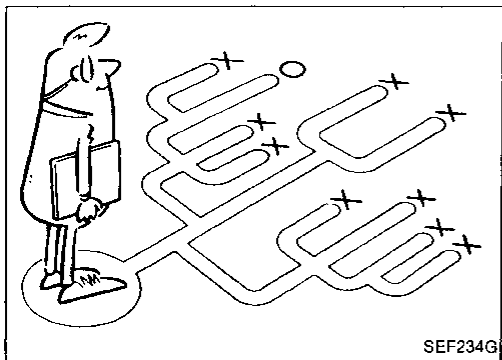

SEF234G

## How to Perform Trouble Diagnoses for Quick and Accurate Repair

### INTRODUCTION

The ABS system has an electronic control unit to control major functions. The control unit accepts input signals from sensors and instantly drives actuator. It is essential that both kinds of signals are proper and stable. It is also important to check for conventional problems: such as air leaks in the booster or lines, lack of brake fluid, or other problems with the brake system.

It is much more difficult to diagnose a problem that occurs intermittently rather than continuously. Most intermittent problems are caused by poor electric connections or faulty wiring. In this case, careful checking of suspicious circuits may help prevent the replacement of good parts.

A visual check only may not find the cause of the problems, so a road test should be performed.

Before undertaking actual checks, take just a few minutes to talk with a customer who approaches with a ABS complaint. The customer is a very good source of information on such problems; especially intermittent ones. Through the talks with the customer, find out what symptoms are present and under what conditions they occur.

Start your diagnosis by looking for "conventional" problems first. This is one of the best ways to troubleshoot brake problems on an ABS controlled vehicle.

## Self-diagnosis

### FUNCTION

- When a problem occurs in the ABS, the warning lamp on the instrument panel comes on. To actuate the self-diagnostic results mode, ground the self-diagnostic (check) terminal located on "Data link connector for CONSULT". The location of the malfunction is indicated by the warning lamp flashing.

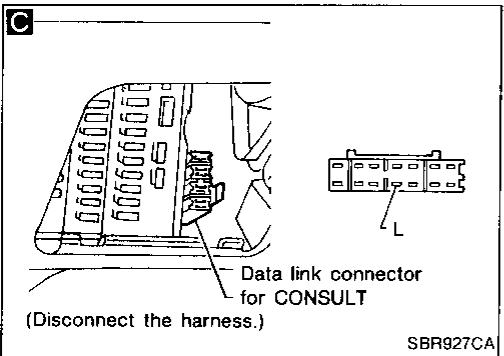
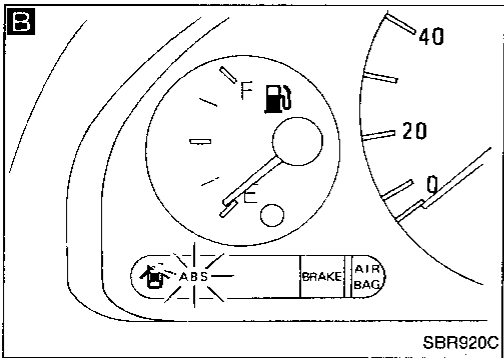
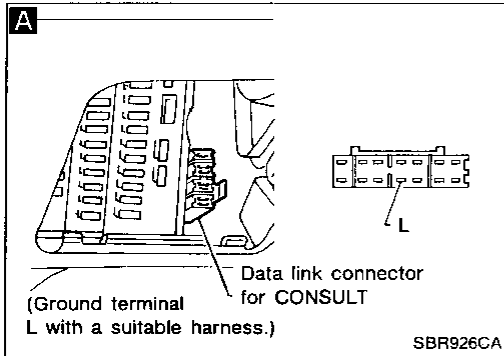

### SELF-DIAGNOSIS PROCEDURE

Drive vehicle over 30 km/h (20 MPH) for at least one minute.

Turn ignition switch "OFF".

**A** Ground terminal "L" of "Data link connector for CONSULT" with a suitable harness.

Turn ignition switch "ON" while grounding terminal "L".  
**Do not depress brake pedal.**

**B** After 3.6 seconds, the warning lamp starts flashing to indicate the malfunction code No. (See NOTE.)

Verify the location of the malfunction with the malfunction code chart (BR-34). Then make the necessary repairs following the diagnostic procedures.

After the malfunctions are repaired, erase the malfunction codes stored in the control unit. Refer to "HOW TO ERASE SELF-DIAGNOSTIC RESULTS" (BR-33).

Rerun the self-diagnostic results mode to verify that the malfunction codes have been erased.

**C** Disconnect the check terminal from the ground. The self-diagnostic results mode is now complete.

**NOTE:** The indication terminates after five minutes. However, when the ignition switch is turned from "OFF" to "ON", the indication starts flashing again.

Ⓐ



# TROUBLE DIAGNOSES

## Self-diagnosis (Cont'd)

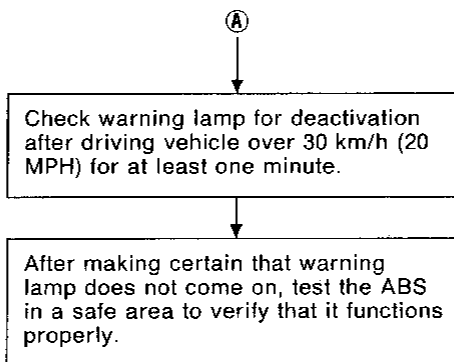

GI  
MA  
EM  
LC  
EC  
FE  
CL  
MT  
AT  
FA  
RA  
BR  
ST  
RS  
BT  
HA  
EL  
IDX

### HOW TO READ SELF-DIAGNOSTIC RESULTS (Malfunction codes)

- Determine the code No. by counting the number of times the warning lamp flashes on and off.
- When several malfunctions occur at one time, up to three code numbers can be stored; the latest malfunction will be indicated first.
- The indication begins with the start code 12. After that a maximum of three code numbers appear in the order of the latest one first. The indication then returns to the start code 12 to repeat (the indication will stay on for five minutes at the most).
- The malfunction code chart is given on the next page.

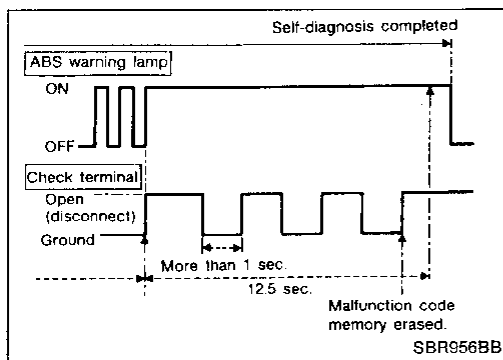
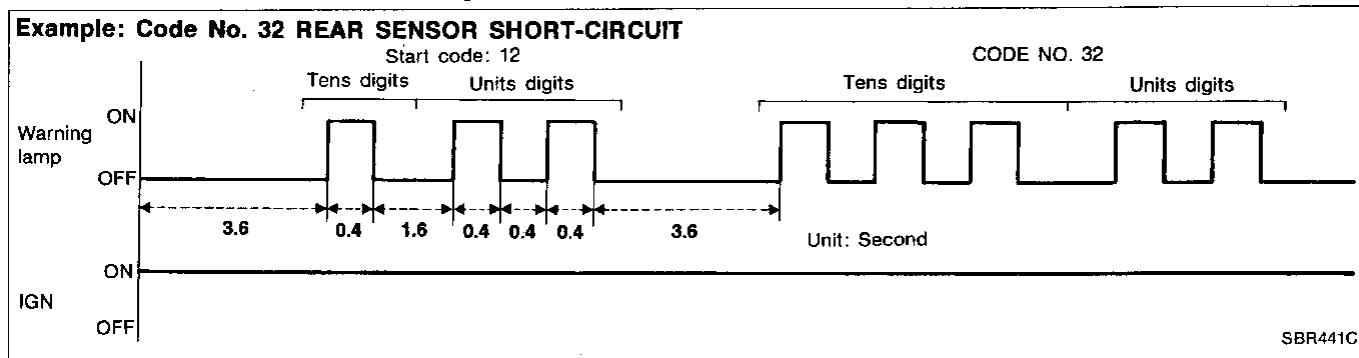

### HOW TO ERASE SELF-DIAGNOSTIC RESULTS (Malfunction codes)

- Disconnect the check terminal from the ground under the self-diagnostic results mode.
- Ground check terminal more than three times within 12.5 seconds. (Each grounding must be longer than one second.)

The ABS warning lamp stays on while the erase mode. Then it goes out after the erase operation has been completed.

The self-diagnosis is also completed at the same time.

**After the erase operation, rerun the self-diagnostic mode. Verify that malfunction codes no longer appear. When the system is functioning normally, only the start code should be indicated.**

## TROUBLE DIAGNOSES

### Self-diagnosis (Cont'd)

#### MALFUNCTION CODE/SYMPTOM CHART

Code No. (No. of LED flashes)	Malfunctioning part	Diagnostic procedure
45	Actuator front left outlet solenoid valve	3
46	Actuator front left inlet solenoid valve	3
41	Actuator front right outlet solenoid valve	3
42	Actuator front right inlet solenoid valve	3
51	Actuator rear right outlet solenoid valve	3
52	Actuator rear right inlet solenoid valve	3
55	Actuator rear left inlet solenoid valve	3
56	Actuator rear left inlet solenoid valve	3
25	Front left sensor (open-circuit)	4
26	Front left sensor (short-circuit)	4
21	Front right sensor (open-circuit)	4
22	Front right sensor (short-circuit)	4
35	Rear left sensor (open-circuit)	4
36	Rear left sensor (short-circuit)	4
31	Rear right sensor (open-circuit)	4
32	Rear right sensor (short-circuit)	4
18	Sensor rotor	4
61	Actuator motor or motor relay	5
63	Solenoid valve relay	6
57	Power supply (Low voltage)	7
71	Control unit	8
Warning lamp stays on when ignition switch is turned on.	Control unit power supply circuit Warning lamp bulb circuit Control unit or control unit connector Solenoid valve relay stuck Power supply for solenoid valve relay coil	2
Warning lamp stays on, during self-diagnosis.	Control unit	—
Warning lamp does not come on when ignition switch is turned on.	Fuse, warning lamp bulb or warning lamp circuit Control unit	1
Warning lamp does not come on during self-diagnosis.	Control unit	—
Pedal vibration and noise	—	9
Long stopping distance	—	10
Unexpected pedal action	—	11
ABS does not work.	—	12
ABS works frequently.	—	13

# TROUBLE DIAGNOSES

## CONSULT

### CONSULT APPLICATION TO ABS

ITEM	SELF-DIAGNOSTIC RESULTS	DATA MONITOR	ACTIVE TEST	
Front right wheel sensor	X	X	—	GI
Front left wheel sensor	X	X	—	MA
Rear right wheel sensor	X	X	—	
Rear left wheel sensor	X	X	—	EM
Stop lamp switch	—	X	—	
Front right inlet solenoid valve	X	X	X	LC
Front right outlet solenoid valve	X	X	X	
Front left inlet solenoid valve	X	X	X	EC
Front left outlet solenoid valve	X	X	X	
Rear right inlet solenoid valve	X	X	X	FE
Rear left inlet solenoid valve	X	X	X	
Rear right outlet solenoid valve	X	X	X	CL
Rear left outlet solenoid valve	X	X	X	
Actuator solenoid valve relay	X	X	—	
Actuator motor relay (ABS MOTOR is shown on the Data Monitor screen.)	X	X	X	MT
ABS warning lamp	—	X	—	AT
Battery voltage (SENSOR VOLT is shown on the Data Monitor screen.)	X	X	—	FA

X: Applicable

—: Not applicable

### ECU part number mode

Ignore the ECU part number displayed in the ECU PART NUMBER MODE. Refer to parts catalog to order the ECU.

RA

BR

ST

RS

BT

HA

EL

IDX

## CONSULT Inspection Procedure SELF-DIAGNOSIS PROCEDURE

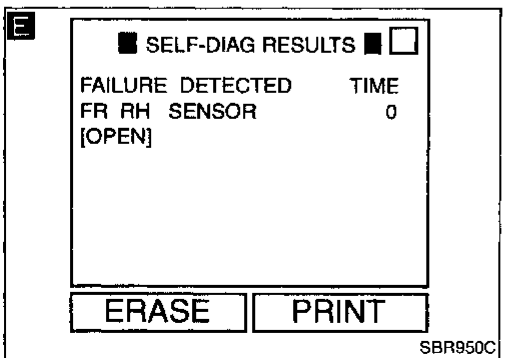
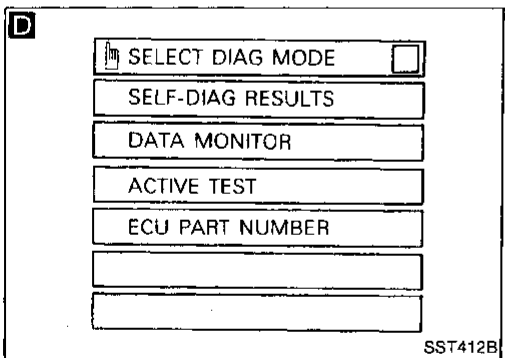
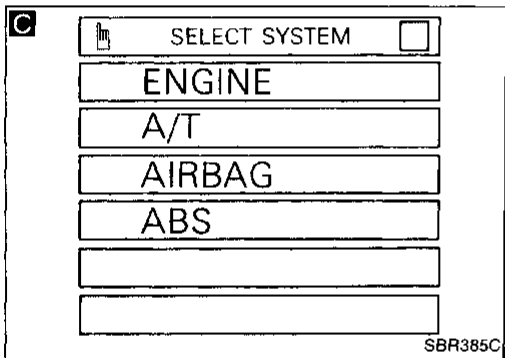
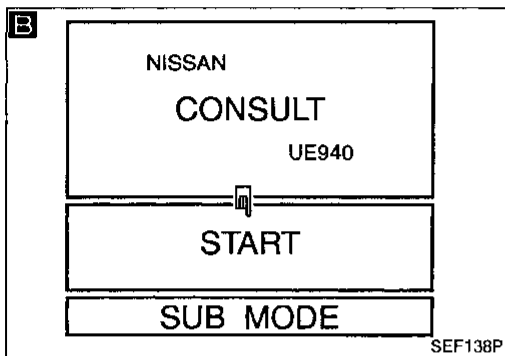
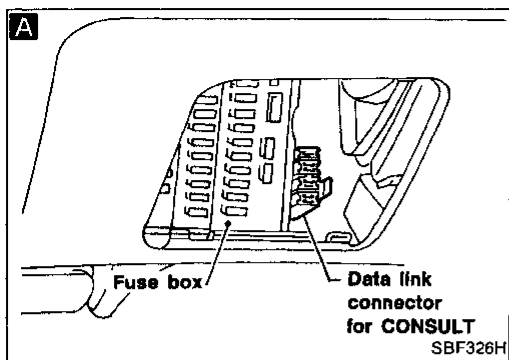

**A**

- 1) Turn ignition switch OFF.
- 2) Connect CONSULT to Data link connector for CONSULT.

- 1) Start engine.
- 2) Drive vehicle over 30 km/h (20 MPH) for at least one minute.

**B** 1) Stop vehicle with engine running and touch "START" on CONSULT screen.

**C** 2) Touch "ABS".

**D** 3) Touch "SELF-DIAG RESULTS".

- The screen shows the detected malfunction and the times of ignition switch ON and OFF after it occurred.

Make the necessary repairs following the diagnostic procedures.

**E**

After the malfunctions are repaired, erase the self-diagnostic results stored in the control unit by touching "ERASE".

Check warning lamp for deactivation after driving vehicle over 30 km/h (20 MPH) for at least one minute.

Test the ABS in a safe area to verify that it functions properly.

**Note:** "SELF-DIAG RESULTS" screen shows the detected malfunction and the times of ignition switch ON and OFF after it occurred.

# TROUBLE DIAGNOSES

## CONSULT Inspection Procedure (Cont'd)

### SELF-DIAGNOSTIC RESULTS MODE

Diagnostic item	Diagnostic item is detected when ...	Diagnostic procedure	
FR RH SENSOR [OPEN]	● Circuit for front right wheel sensor is open. (An abnormally high input voltage is entered.)	4	GI
FR LH SENSOR [OPEN]	● Circuit for front left wheel sensor is open. (An abnormally high input voltage is entered.)	4	
RR RH SENSOR [OPEN]	● Circuit for rear right sensor is open. (An abnormally high input voltage is entered.)	4	MA
RR LH SENSOR [OPEN]	● Circuit for rear left sensor is open. (An abnormally high input voltage is entered.)	4	EM
FR RH SENSOR [SHORT]	● Circuit for front right wheel sensor is shorted. (An abnormally low input voltage is entered.)	4	
FR LH SENSOR [SHORT]	● Circuit for front left wheel sensor is shorted. (An abnormally low input voltage is entered.)	4	LC
RR RH SENSOR [SHORT]	● Circuit for rear right sensor is shorted. (An abnormally low input voltage is entered.)	4	EC
RR LH SENSOR [SHORT]	● Circuit for rear left sensor is shorted. (An abnormally low input voltage is entered.)	4	
ABS SENSOR [ABNORMAL SIGNAL]	● Teeth damage on sensor rotor or improper installation of wheel sensor. (Abnormal wheel sensor signal is entered.)	4	FE
FR RH IN ABS SOL [OPEN]	● Circuit for front right inlet solenoid valve is open. (An abnormally low output voltage is entered.)	3	CL
FR LH IN ABS SOL [OPEN]	● Circuit for front left inlet solenoid valve is open. (An abnormally low output voltage is entered.)	3	
RR RH IN ABS SOL [OPEN]	● Circuit for rear right inlet solenoid valve is open. (An abnormally low output voltage is entered.)	3	MT
RR LH IN ABS SOL [OPEN]	● Circuit for rear left inlet solenoid valve is open. (An abnormally low output voltage is entered.)	3	AT
FR RH IN ABS SOL [SHORT]	● Circuit for front right inlet solenoid valve is shorted. (An abnormally high output voltage is entered.)	3	
FR LH IN ABS SOL [SHORT]	● Circuit for front left inlet solenoid valve is shorted. (An abnormally high output voltage is entered.)	3	FA
RR RH IN ABS SOL [SHORT]	● Circuit for rear right inlet solenoid valve is shorted. (An abnormally high output voltage is entered.)	3	RA
RR LH IN ABS SOL [SHORT]	● Circuit for rear left inlet solenoid valve is shorted. (An abnormally high output voltage is entered.)	3	
FR RH OUT ABS SOL [OPEN]	● Circuit for front right outlet solenoid valve is open. (An abnormally low output voltage is entered.)	3	BR
FR LH OUT ABS SOL [OPEN]	● Circuit for front left outlet solenoid valve is open. (An abnormally low output voltage is entered.)	3	ST
RR RH OUT ABS SOL [OPEN]	● Circuit for rear right outlet solenoid valve is open. (An abnormally low output voltage is entered.)	3	
RR LH OUT ABS SOL [OPEN]	● Circuit for rear left outlet solenoid valve is open. (An abnormally low output voltage is entered.)	3	RS
FR RH OUT ABS SOL [SHORT]	● Circuit for front right outlet solenoid valve is shorted. (An abnormally high output voltage is entered.)	3	BT
FR LH OUT ABS SOL [SHORT]	● Circuit for front left outlet solenoid valve is shorted. (An abnormally high output voltage is entered.)	3	
RR RH OUT ABS SOL [SHORT]	● Circuit for rear right outlet solenoid valve is shorted. (An abnormally high output voltage is entered.)	3	HA
RR LH OUT ABS SOL [SHORT]	● Circuit for rear left outlet solenoid valve is shorted. (An abnormally high output voltage is entered.)	3	EL
ABS ACTUATOR RELAY [FAILURE]	● Actuator solenoid valve relay is ON, even control unit sends off signal. ● Actuator solenoid valve relay is OFF, even control unit sends on signal.	6	
ABS MOTOR [FAILURE]	● Circuit for actuator motor is open or shorted. ● Actuator motor relay is stuck.	5	IDX
BATTERY VOLT [VB-LOW]	● Power source voltage supplied to ABS control unit is abnormally low.	7	
CONTROL UNIT	● Function of calculation in ABS control unit has failed.	8	

# TROUBLE DIAGNOSES

## CONSULT Inspection Procedure (Cont'd)

### DATA MONITOR PROCEDURE

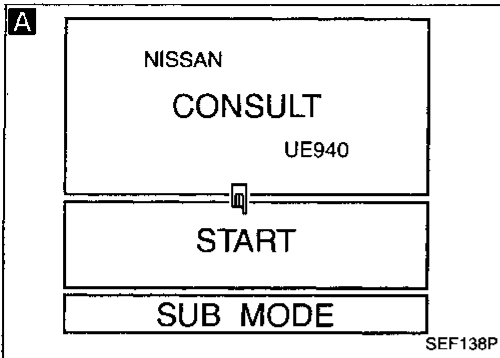

- 1) Turn ignition switch OFF.
- 2) Connect CONSULT to Data link connector for CONSULT.
- 3) Turn ignition switch ON.

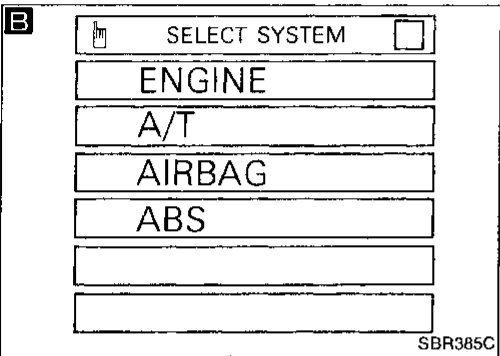

- A** 1) Touch "START" on CONSULT screen.
- B** 2) Touch "ABS".
- C** 3) Touch "DATA MONITOR".

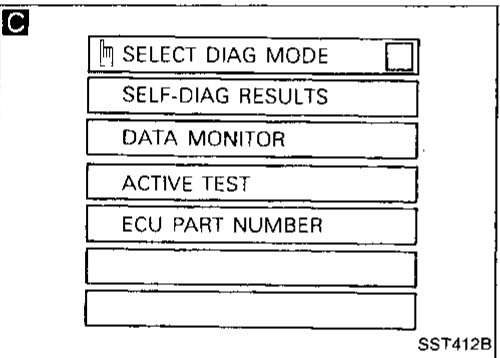

- D** 1) Touch "SETTING" on "SELECT MONITOR ITEM" screen.
- E** 2) Touch "LONG TIME" on "SET RECORDING COND" screen.
- D** 3) Touch "START" on "SELECT MONITOR ITEM".

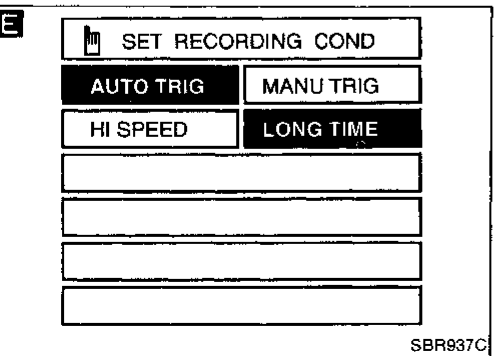
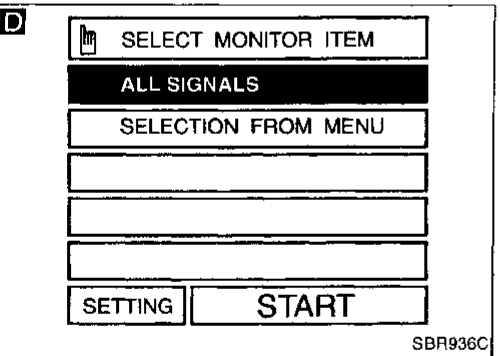

# TROUBLE DIAGNOSES

## CONSULT Inspection Procedure (Cont'd)

### ACTIVE TEST PROCEDURE

- When conducting Active test, vehicle must be stationary.
- When ABS warning lamp stays on, never conduct Active test.

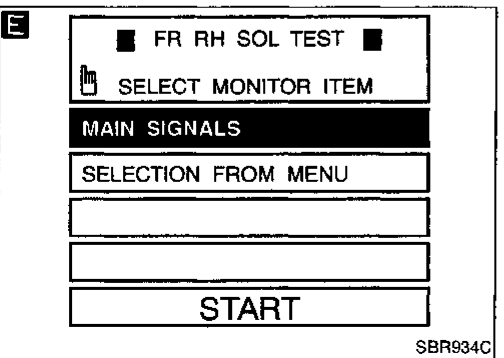
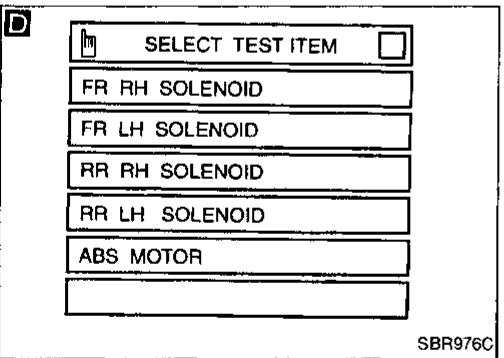
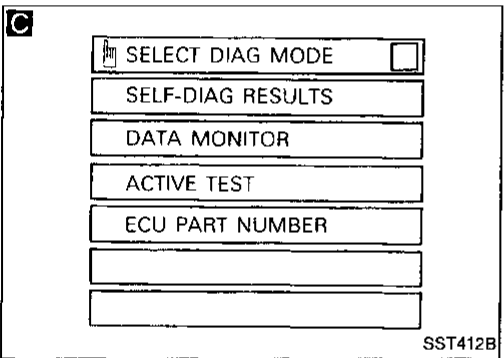
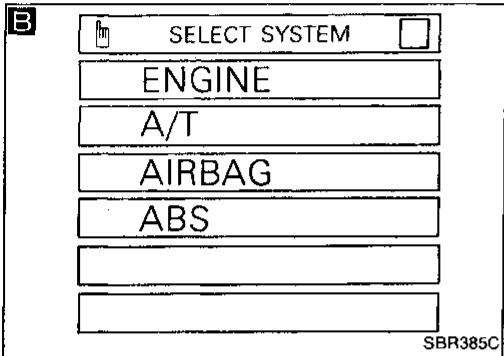
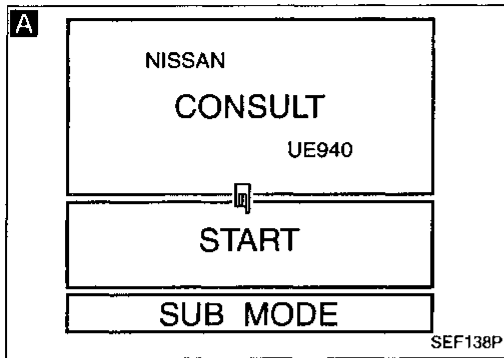

- 1) Turn ignition switch OFF.
- 2) Connect CONSULT to Data link connector for CONSULT.
- 3) Start engine.

- 1) Touch "START" on CONSULT screen.
- 2) Touch "ABS".
- 3) Touch "ACTIVE TEST".

- 1) Select active test item by touching screen.
- 2) Touch "START".

Carry out the active test by touching screen key.

GI

MA

EM

LC

EC

FE

CL

MT

AT

FA

RA

BR

ST

RS

BT

HA

EL

IDX

## TROUBLE DIAGNOSES

### CONSULT Inspection Procedure (Cont'd)

#### DATA MONITOR MODE

MONITOR ITEM	CONDITION	SPECIFICATION
FR RH SENSOR FR LH SENSOR REAR RH SENSOR REAR LH SENSOR	Drive vehicle. (Each wheel is rotating.)	Almost the same speed as speedometer.
STOP LAMP SW	Brake is depressed.	Depress the pedal: ON Release the pedal: OFF
FR RH IN SOL FR RH OUT SOL FR LH IN SOL FR LH OUT SOL RR RH IN SOL RR RH OUT SOL RR LH IN SOL RR LH OUT SOL	Engine is running.	Operating conditions for each solenoid valve are indicated. ABS is not operating: OFF
ACTUATOR RLY	Ignition switch is ON or engine is running.	Ignition switch ON (Engine stops): OFF Engine running: ON
MOTOR RELAY		ABS is not operating: OFF ABS is operating: ON
WARNING LAMP		Warning lamp is turned on: ON Warning lamp is turned off: OFF
SENSOR VOLT		Power supply voltage for control unit

#### ACTIVE TEST MODE

TEST ITEM	CONDITION	JUDGEMENT												
FR RH SOLENOID FR LH SOLENOID RR RH SOLENOID RR LH SOLENOID	Engine is running.	Brake fluid pressure control operation  <table style="width: 100%; border: none;"> <tr> <td></td> <td style="text-align: center;">IN SOL</td> <td style="text-align: center;">OUT SOL</td> </tr> <tr> <td>UP (Increase):</td> <td style="text-align: center;">OFF</td> <td style="text-align: center;">OFF</td> </tr> <tr> <td>KEEP (Hold):</td> <td style="text-align: center;">ON</td> <td style="text-align: center;">OFF</td> </tr> <tr> <td>DOWN (Decrease):</td> <td style="text-align: center;">ON</td> <td style="text-align: center;">ON</td> </tr> </table>		IN SOL	OUT SOL	UP (Increase):	OFF	OFF	KEEP (Hold):	ON	OFF	DOWN (Decrease):	ON	ON
		IN SOL	OUT SOL											
UP (Increase):	OFF	OFF												
KEEP (Hold):	ON	OFF												
DOWN (Decrease):	ON	ON												
ABS MOTOR		ABS actuator motor ON: Motor runs OFF: Motor stops												

**Note: Active test will automatically stop ten seconds after the test starts. (LIMIT SIGNAL monitor shows ON.)**



Component Parts and Harness Connector Location

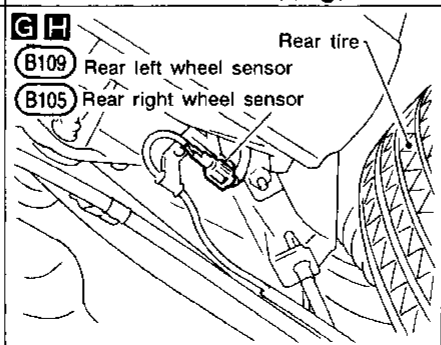
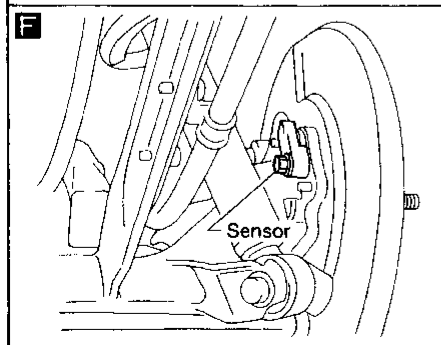
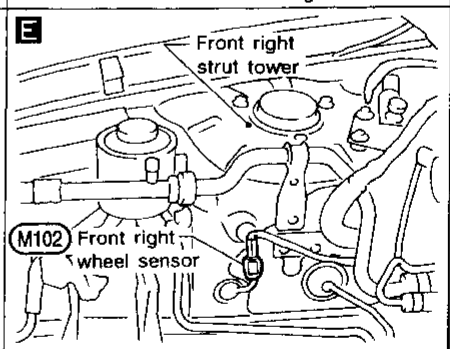
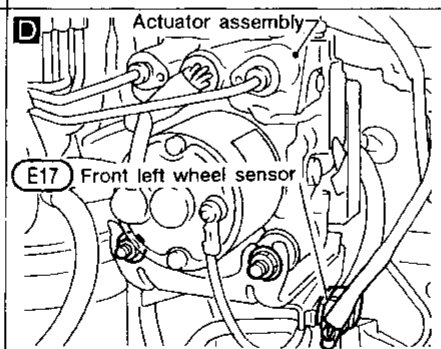
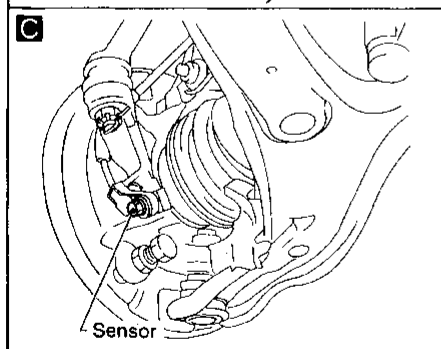
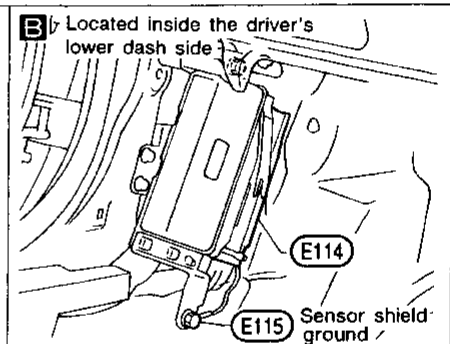
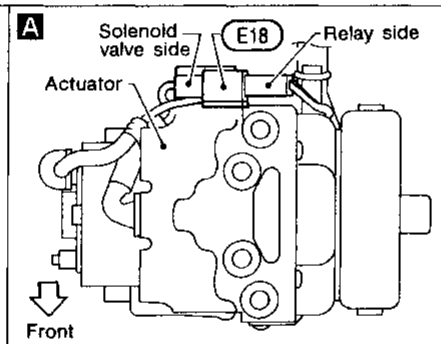
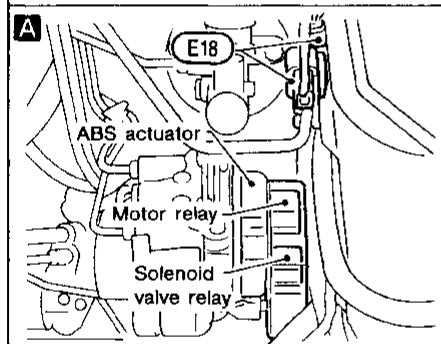
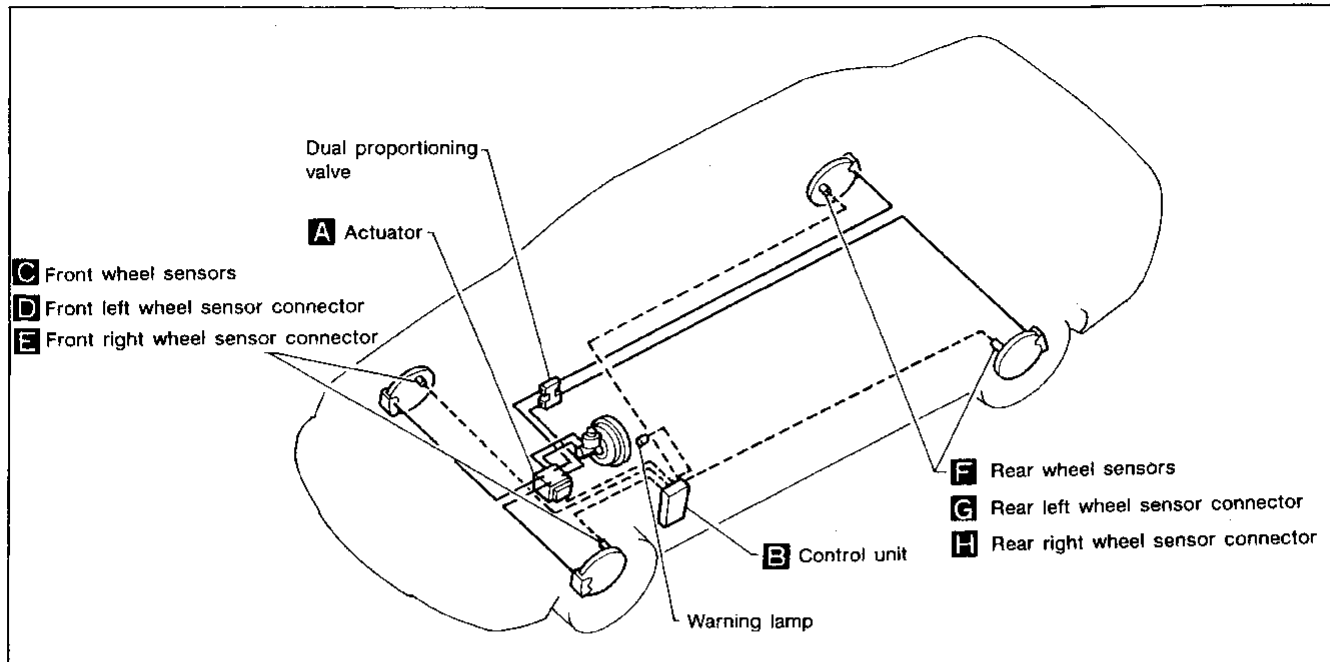

GI  
MA  
EM  
LC  
EC  
FE  
CL  
MT  
AT  
FA  
RA  
BR  
ST  
RS  
BT  
HA  
EL  
IDX

# TROUBLE DIAGNOSES

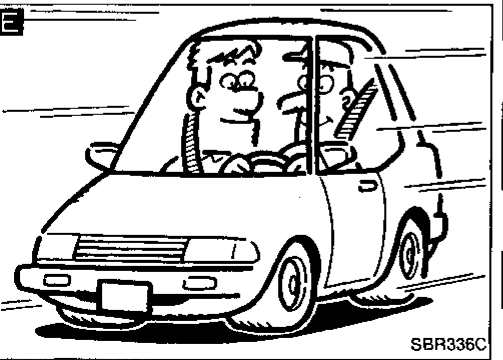
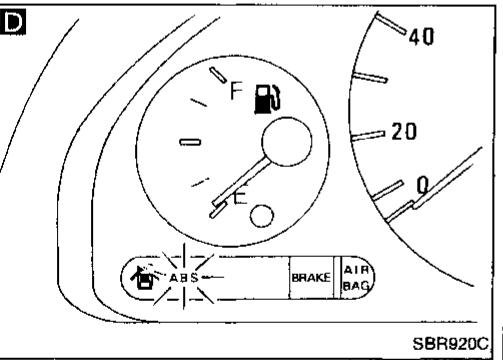
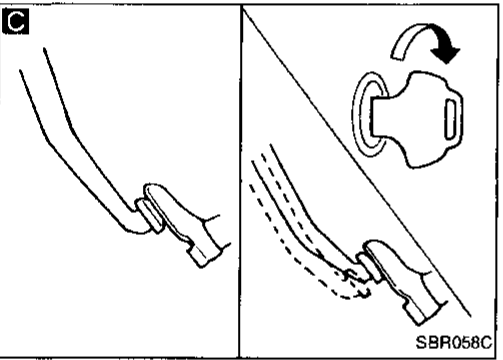
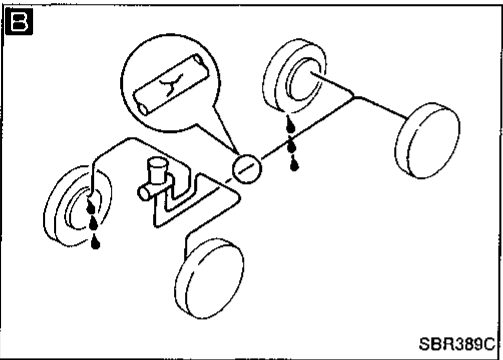
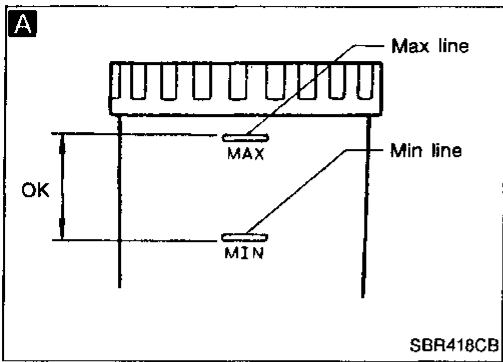

## Preliminary Check

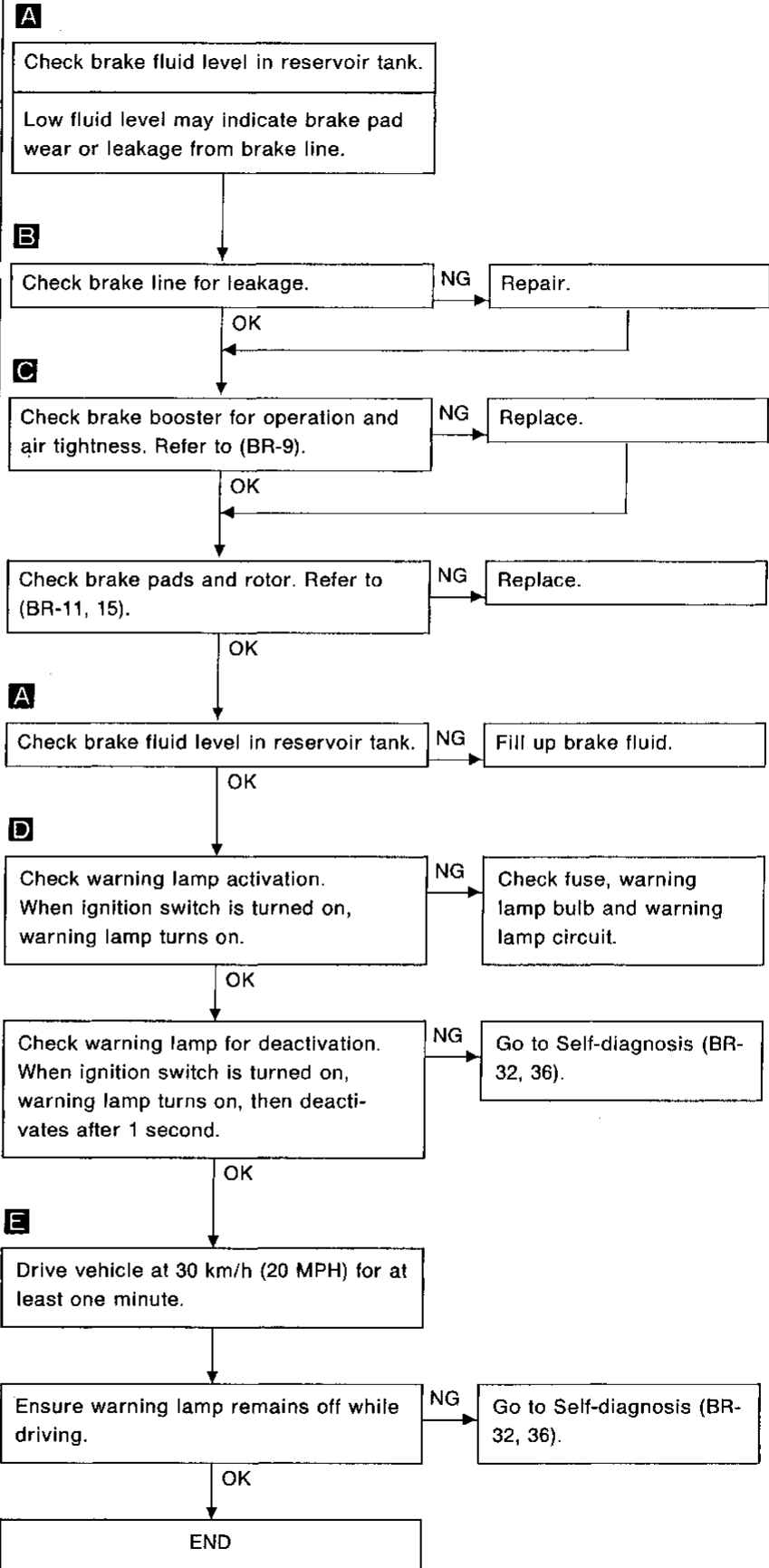

# TROUBLE DIAGNOSES

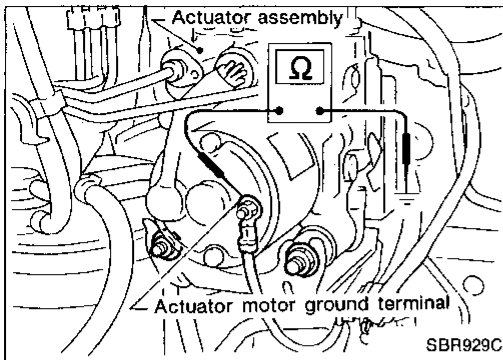

## Ground Circuit Check

### ACTUATOR MOTOR GROUND

- Check resistance between actuator motor ground terminal and body ground.

**Resistance: 0Ω**

GI

MA

EM

LC

EC

FE

CL

MT

AT

FA

RA

**BR**

ST

RS

BT

HA

EL

IDX

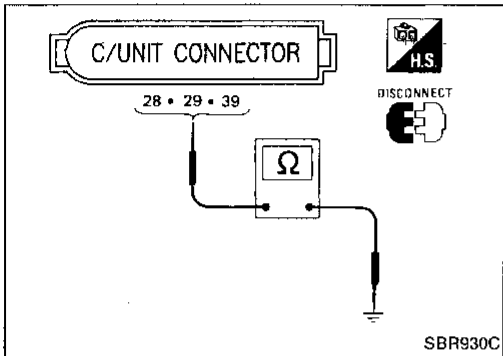

### CONTROL UNIT GROUND

- Check resistance between the terminals and ground.

**Resistance: 0Ω**

LC

EC

FE

CL

MT

AT

FA

RA

**BR**

ST

RS

BT

HA

EL

IDX

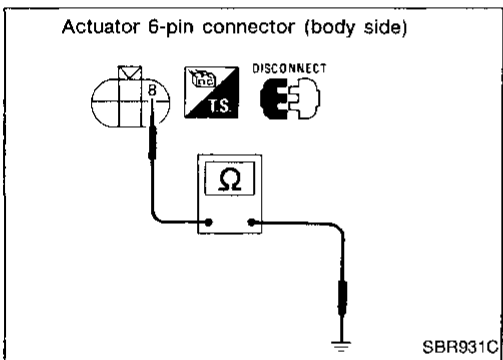

### ACTUATOR GROUND

- Check resistance between actuator harness 6-pin connector (body side) terminal ⑧ and ground.

**Resistance: 0Ω**

MT

AT

FA

RA

**BR**

ST

RS

BT

HA

EL

IDX

# TROUBLE DIAGNOSES

## Circuit Diagram for Quick Pinpoint Check

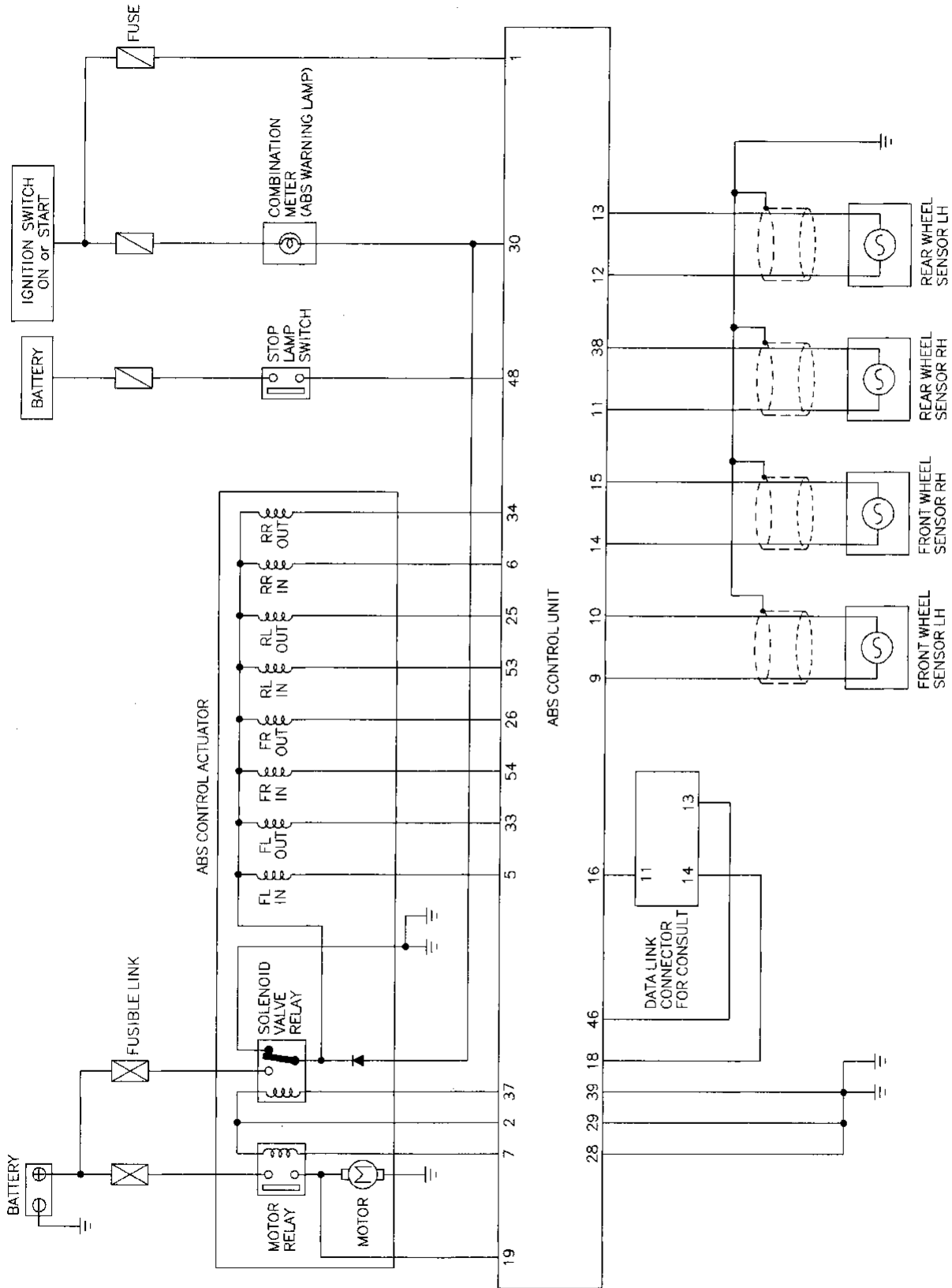

# TROUBLE DIAGNOSES

## Diagnostic Procedure 1 (Not self-diagnostic item)

**Warning lamp does not work before engine starts.**

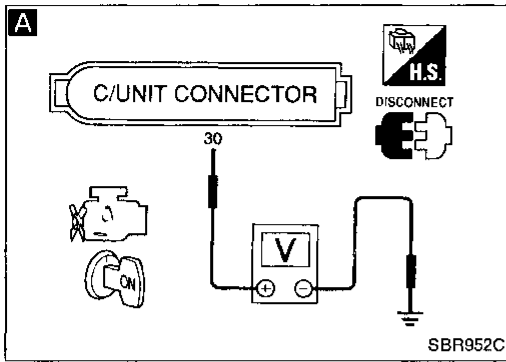

**WARNING LAMP CIRCUIT CHECK** NG → Replace fuse.

Check 10A fuse [13] for warning lamp. For fuse layout, refer to POWER SUPPLY ROUTING in EL section.

OK ↓

CI  
MA

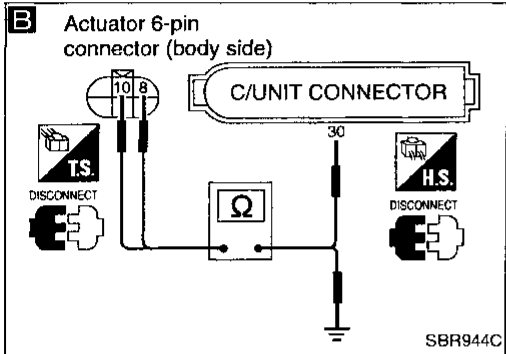

Check warning lamp bulb. NG → Replace bulb.

OK ↓

EM  
LC

**A**

- Install 10A fuse and bulb.
- Disconnect connectors from control unit and actuator.
- Check voltage between control unit connector terminal 30 and ground after turning ignition switch "ON". **Battery voltage should exist after turning ignition switch "ON".**

NG → Repair harness and connectors.

OK ↓

EC  
FE

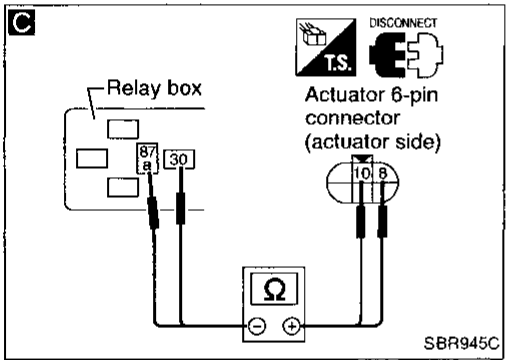

**B**

- Check continuity between actuator connector (body side) and control unit terminals.

NG → Repair harness and connectors.

CL  
MT

Actuator	Control unit
⑩	③①
⑧	Ground

**Continuity should exist.**

OK ↓

AT  
FA

**C**

- Remove solenoid valve relay.
- Check continuity between actuator connector (actuator side) and relay box terminals.

NG → Replace actuator.

Actuator	Relay box
⑩ ⊕	③① ⊖
⑧	⑧⑦a

**Continuity should exist.**  
**Note: Pay attention to tester polarity\*.**

OK ↓

RA  
**BR**

**SOLENOID VALVE RELAY CHECK** NG → Replace solenoid valve relay.

Refer to SOLENOID VALVE RELAY in Electrical Components Inspection (BR-62).

OK ↓

ST  
RS

Go to diagnostic procedure 7 (BR-58).

BT  
HA

\*: Specifications may vary depending on the type of tester. Before performing this inspection, refer to the instruction manual of the tester.

EL  
IDX

## Diagnostic Procedure 2 (Not Self-diagnostic item)

**Warning lamp stays on continuously.**

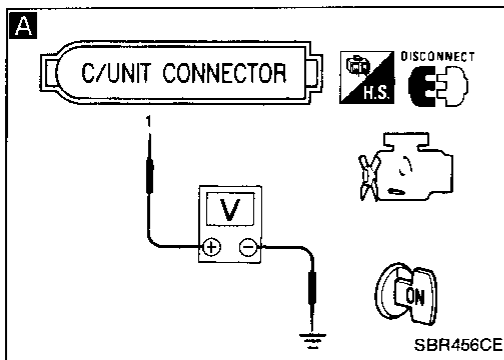

**CONTROL UNIT POWER SUPPLY CIRCUIT**

Check 10A fuse 15 for control unit. For fuse layout, refer to POWER SUPPLY ROUTING in EL section.

NG → (Go to ⑧ on BR-48.)

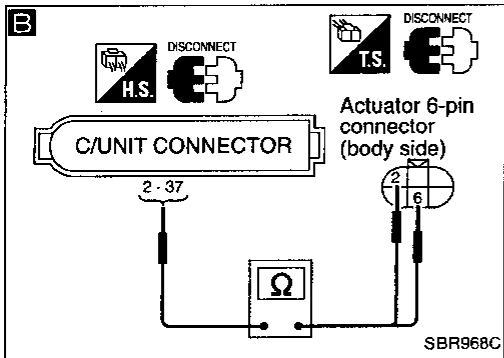

**A**

- Disconnect connector from control unit.
- Check voltage between control unit connector terminal ① and ground after turning ignition switch "ON". **Battery voltage should exist.**

NG → Repair harness and connector.

**B**

**SOLENOID VALVE RELAY COIL POWER SUPPLY CIRCUIT**

- Turn ignition switch "OFF". Disconnect actuator 6-pin connector.
- Check continuity between control unit connector terminals and actuator 6-pin connector (body side) terminals.

Control unit	Actuator
②	②
⑤⑦	⑥

**Continuity should exist.**

NG → Repair harness and connector.

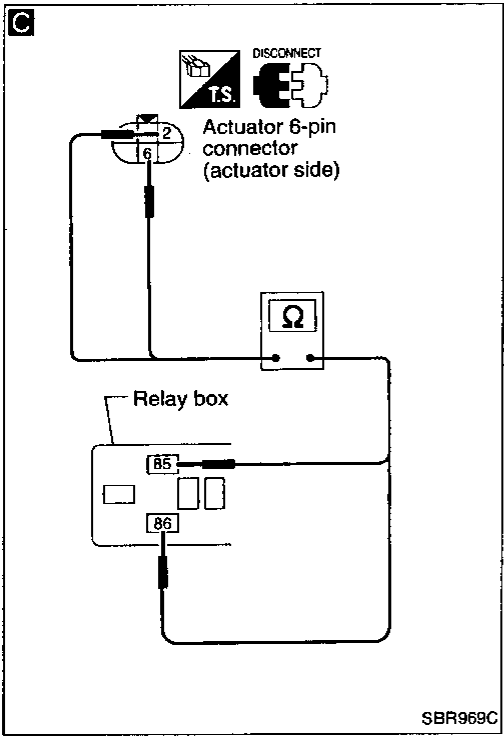

**C**

**CIRCUIT CHECK**

- Disconnect solenoid valve relay.
- Check continuity between actuator 6-pin connector (actuator side) terminals and solenoid valve relay box terminals.

Actuator	Relay box
②	⑧⑥
⑥	⑧⑤

**Continuity should exist.**

NG → Replace actuator.

**SOLENOID VALVE RELAY CHECK**

Refer to SOLENOID VALVE RELAY in Electrical Components Inspection (BR-62).

NG → Replace solenoid valve relay.

OK  
 ↓  
 ⑨  
 (Go to next page.)

# TROUBLE DIAGNOSES

## Diagnostic Procedure 2 (Not Self-diagnostic item) (Cont'd)

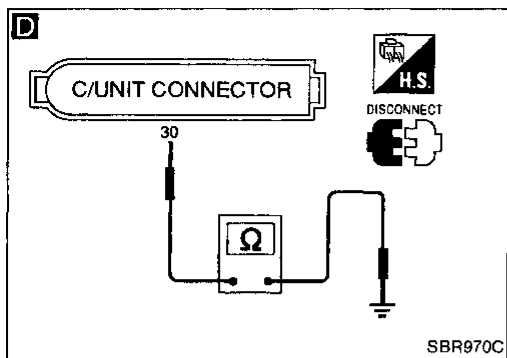

**D**

GROUND-SHORT CHECK FOR WARNING LAMP CIRCUIT.

NG → Repair harness and connector.

- Turn ignition switch "OFF".
- Disconnect connectors from control unit and actuator.
- Check continuity between control unit connector terminal ⑩ and body ground.

**Continuity should not exist.**

OK →

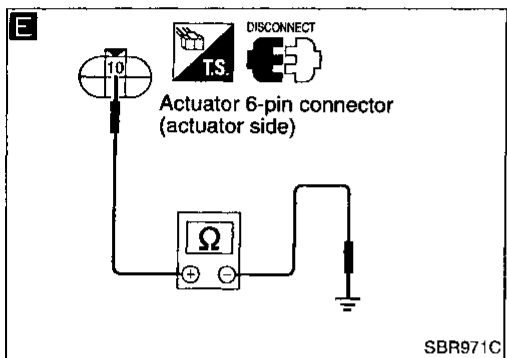

**E**

- Disconnect actuator ground terminal and 6-pin connector.
- Check continuity between actuator 6-pin connector (actuator side) terminal ⑩ and body ground.

**Continuity should not exist.**

**Note: Pay attention to tester polarity\*.**

NG → Replace relay box.

OK →

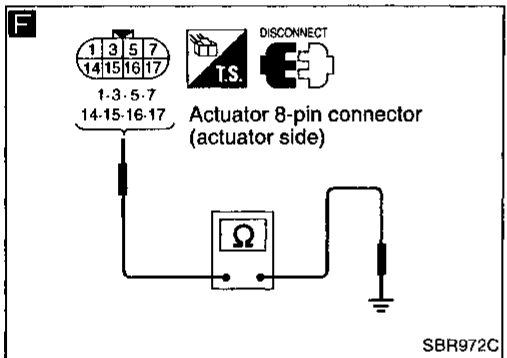

**F**

SOLENOID VALVE CIRCUIT

NG → Replace actuator assembly.

- Disconnect actuator 8-pin connector.
- Check continuity between each actuator 8-pin connector (actuator side) terminals and body ground.

**Continuity should not exist.**

OK →

Replace control unit.

\*: Specifications may vary depending on the type of tester.  
Before performing this inspection, refer to the instruction manual of the tester.

GI  
MA  
EM  
LC  
EC  
FE  
CL  
MT  
AT  
FA  
RA  
BR  
ST  
RS  
BT  
HA  
EL  
IDX

# TROUBLE DIAGNOSES

## Diagnostic Procedure 2 (Not Self-diagnostic item) (Cont'd)

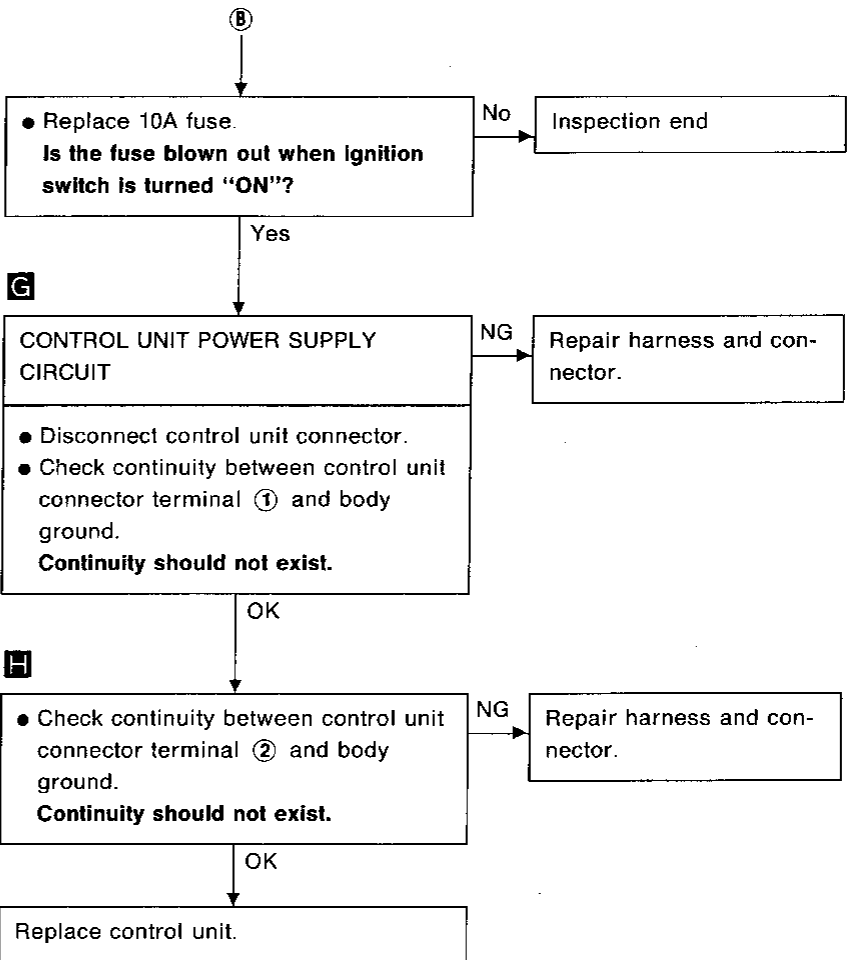
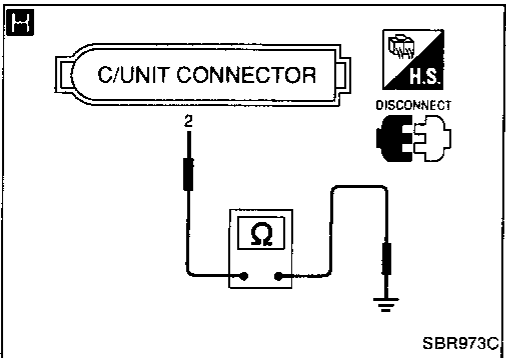
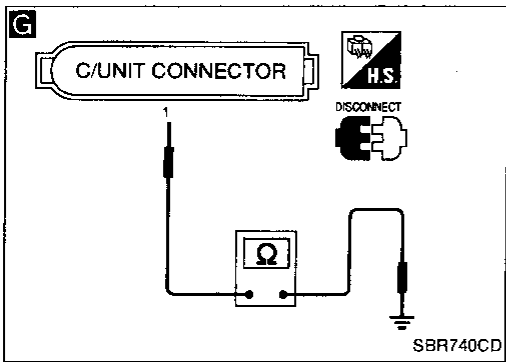



# TROUBLE DIAGNOSES

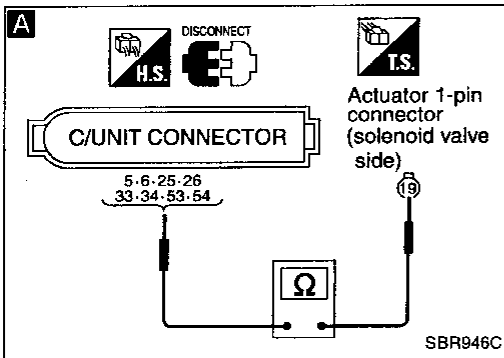

## Diagnostic Procedure 3

### ACTUATOR SOLENOID VALVE

(Malfunction code No. 41, 45, 51, 55, 42, 46, 52, 56)

- Disconnect connectors from control unit and actuator. Check terminals for damage or loose connection. Then reconnect connectors.
  - Carry out self-diagnosis again.
- Does warning lamp activate again?**

No → Inspection end

GI  
MA  
EM  
LC  
EC  
FE  
CL  
WT  
AT  
FA  
RA  
BR  
ST  
RS  
BT  
HA  
EL  
IDX

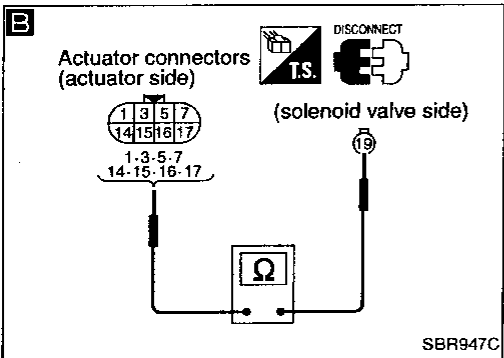

- A**
- Yes
- ACTUATOR SOLENOID VALVE CHECK
- Disconnect connectors from control unit and actuator.
  - Check resistance between control unit connector terminals and actuator 1-pin connector (solenoid valve side) terminal.

OK → (A) (Go to next page.)

Code No.	Control unit	Actuator	Resistance
41	(26)	(19)	4.4 - 6.0Ω
45	(33)	(19)	
51	(34)	(19)	
55	(25)	(19)	
42	(54)	(19)	8.5 - 9.5Ω
46	(5)	(19)	
52	(6)	(19)	
56	(53)	(19)	

- B**
- NG
- Disconnect actuator 8-pin connector.
  - Check resistance between actuator 8-pin connector (actuator side) terminals and 1-pin connector (solenoid valve side) terminal.

OK → Repair harness and connector between control unit connector terminal and actuator 8-pin connector terminal.

Code No.	Actuator	Resistance
41	(15) - (19)	4.4 - 6.0Ω
45	(14) - (19)	
51	(17) - (19)	
55	(16) - (19)	8.5 - 9.5Ω
42	(3) - (19)	
46	(1) - (19)	
52	(7) - (19)	
56	(5) - (19)	

NG

Replace actuator.

# TROUBLE DIAGNOSES

## Diagnostic Procedure 3 (Cont'd)

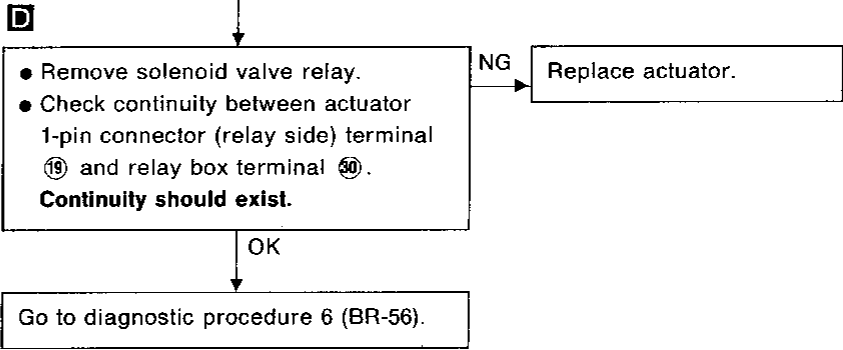
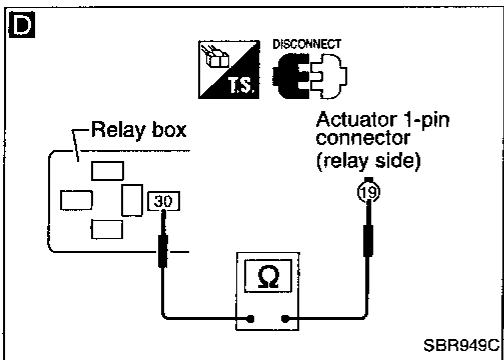
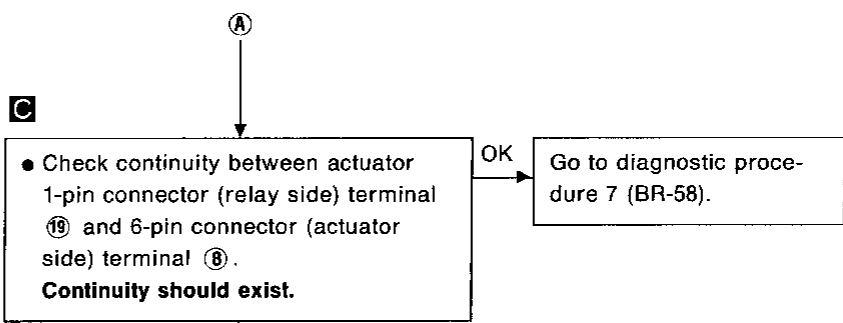
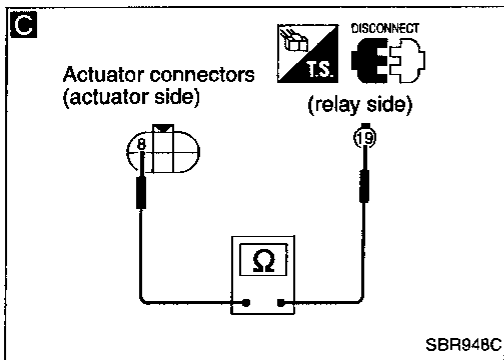

# TROUBLE DIAGNOSES

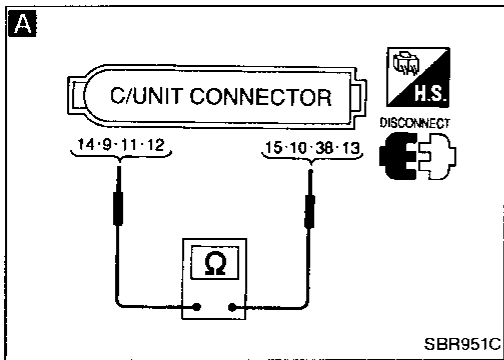

## Diagnostic Procedure 4

### WHEEL SENSOR OR ROTOR

(Malfunction code No. 21, 22, 25, 26, 31, 32, 35, 36 or 18)

- Disconnect connectors from control unit and wheel sensor of malfunction code No. Check terminals for damage or loose connection. Then reconnect connectors.
  - Carry out self-diagnosis again.
- Does warning lamp activate again?**

No → Inspection end

Yes

**A**

#### WHEEL SENSOR ELECTRICAL CHECK

OK → (A) (See next page.)

- Disconnect control unit connector.
  - Check resistance between control unit connector terminals.
- Code No. 21 or 22 (Front RH wheel)  
Terminals ⑭ and ⑮
- Code No. 25 or 26 (Front LH wheel)  
Terminals ⑨ and ⑩
- Code No. 31 or 32 (Rear RH wheel)  
Terminals ⑪ and ⑳
- Code No. 35 or 36 (Rear LH wheel)  
Terminals ⑫ and ⑬
- Resistance: 0.8 - 1.2 kΩ**

NG

Note

CHECK WHEEL SENSOR.

Refer to WHEEL SENSOR in Electrical Components Inspection (BR-62).

NG → Note  
Replace wheel sensor.

OK

Note

Repair harness and connectors between control unit connector and wheel sensor connector.

**Note: Wheel position should be distinguished by code No. except code No. 18 (sensor rotor).**

GI  
MA  
EM  
LC  
EC  
FE  
CL  
MT  
AT  
FA  
RA  
BR  
ST  
RS  
BT  
HA  
EL  
DX

# TROUBLE DIAGNOSES

## Diagnostic Procedure 4 (Cont'd)

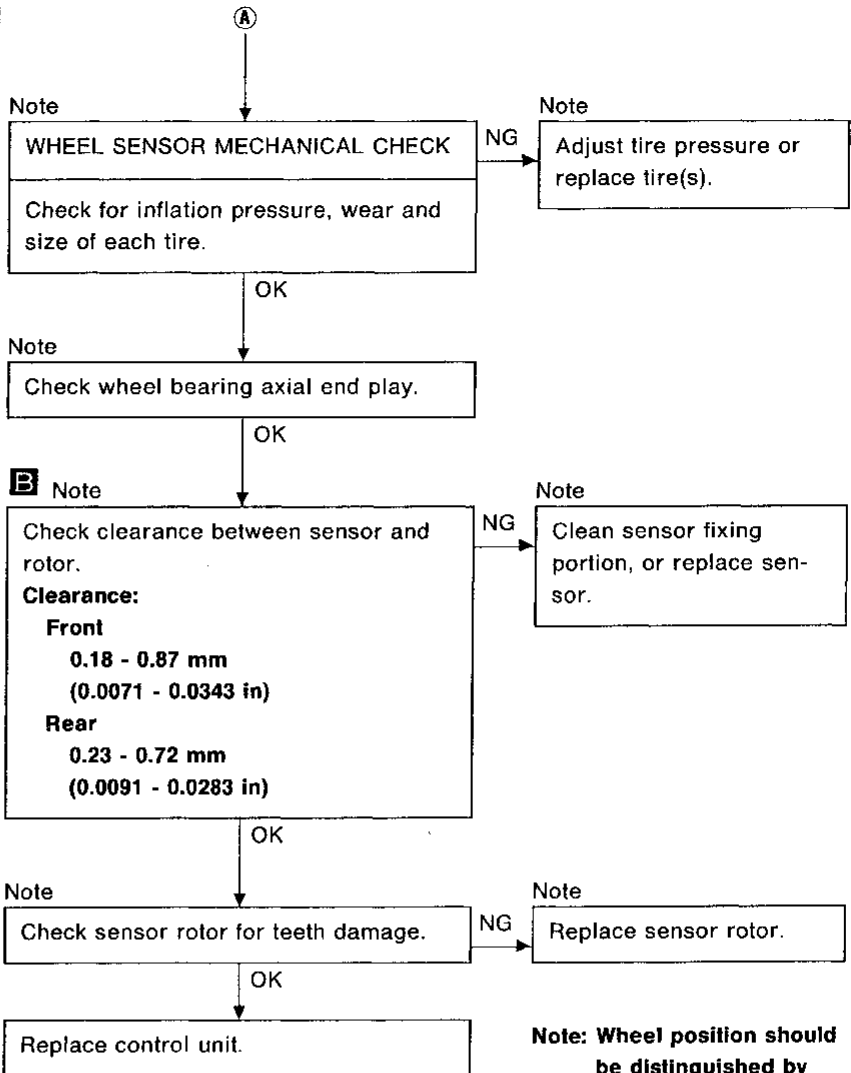
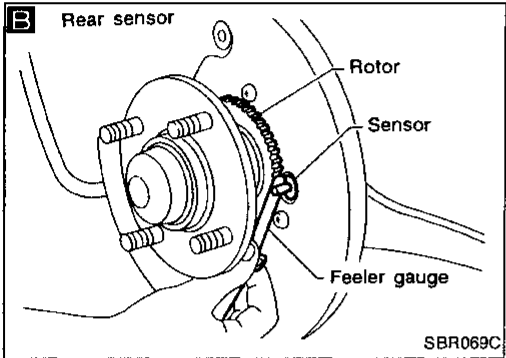
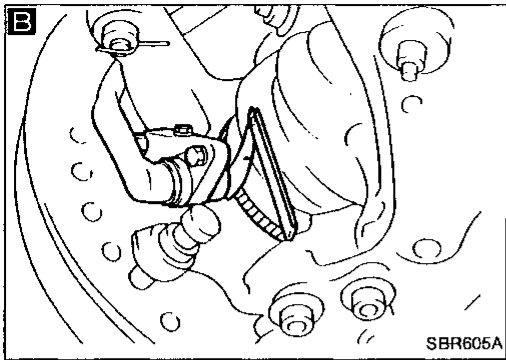

**Note:** Wheel position should be distinguished by code No. except code No. 18 (sensor rotor).

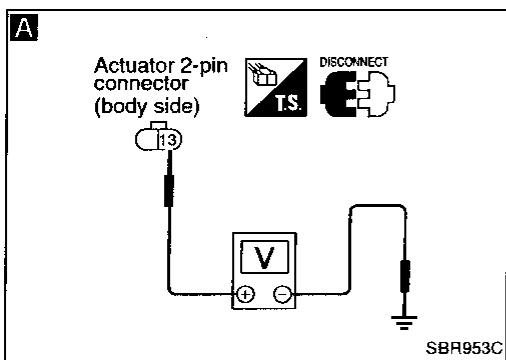

## Diagnostic Procedure 5 MOTOR RELAY OR MOTOR (Malfunction code No. 61)

### MOTOR POWER SUPPLY CIRCUIT

NG → ⑩ (Skip page.)

- Check fusible link ⑨ for actuator. For fusible link layout, refer to POWER SUPPLY ROUTING in EL section.

OK

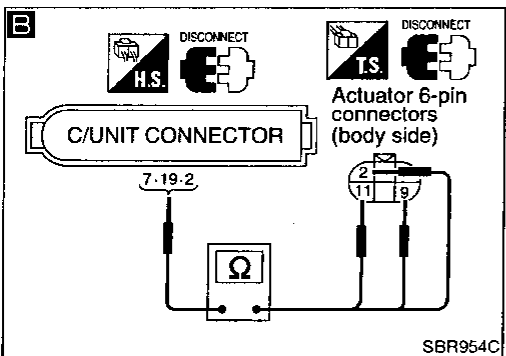

- Disconnect connectors from control unit and actuator. Check terminals for damage or loose connection. Then reconnect connectors.
- Carry out self-diagnosis again.  
**Does warning lamp activate again?**

No → Inspection end

Yes

**A**

- Disconnect actuator 2-pin connector.
- Check voltage between connector (body side) terminal ⑬ and ground.  
**Battery voltage should exist.**

NG → Repair harness and connectors.

OK

**B**

### CIRCUIT CHECK

NG → Repair harness and connectors.

- Disconnect actuator 6-pin connector and control unit connector.
- Check continuity between control unit connector terminals and actuator 6-pin connector (body side) terminals.

Control unit	Actuator
⑦	⑪
⑱	⑨
②	②

**Continuity should exist.**

OK

### MOTOR RELAY CHECK

NG → Replace motor relay.

Refer to MOTOR RELAY in Electrical Components Inspection (BR-62).

OK

### ACTUATOR MOTOR GROUND CHECK

NG → Repair harness and terminals.

Refer to ACTUATOR MOTOR GROUND in Ground Circuit Check (BR-43).

OK

⑩

(Go to next page.)

# TROUBLE DIAGNOSES

## Diagnostic Procedure 5 (Cont'd)

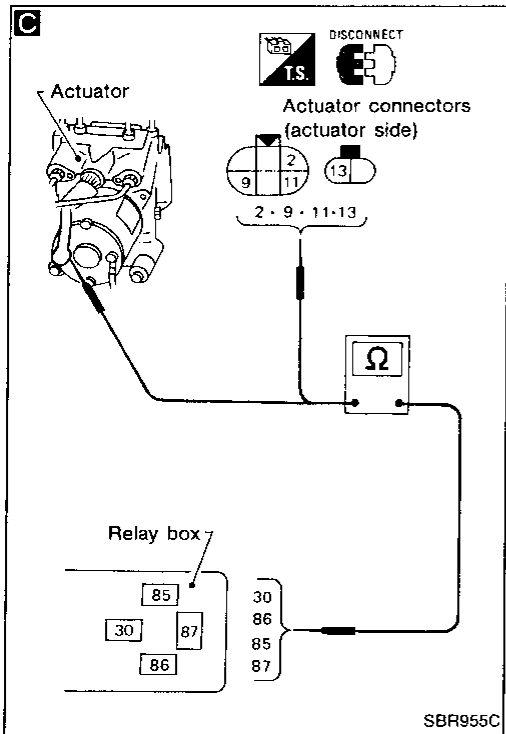

**C**

**MOTOR RELAY CIRCUIT**

NG → Replace relay box assembly.

- Remove motor relay.
- Check continuity between actuator connector (actuator side) terminals and relay connector terminals.

Actuator connector	Relay connector
②	⑧⑥
⑪	⑧⑤
⑨	③⑦
⑬	⑧⑦
Actuator motor positive terminal	③⑦

**Continuity should exist.**

OK

**D**

**MOTOR CHECK**

NG → Replace actuator assembly.

- Connect actuator connectors.
- Connect suitable wire between relay connector terminals ③⑦ and ⑧⑦.

**Motor should operate.**

**Do not connect wire for more than 5 seconds.**

OK

Go to diagnostic procedure 7 (BR-58).

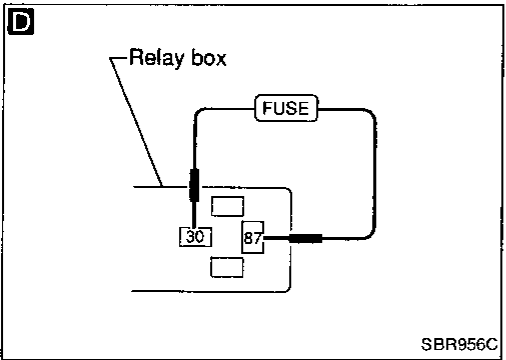

# TROUBLE DIAGNOSES

## Diagnostic Procedure 5 (Cont'd)

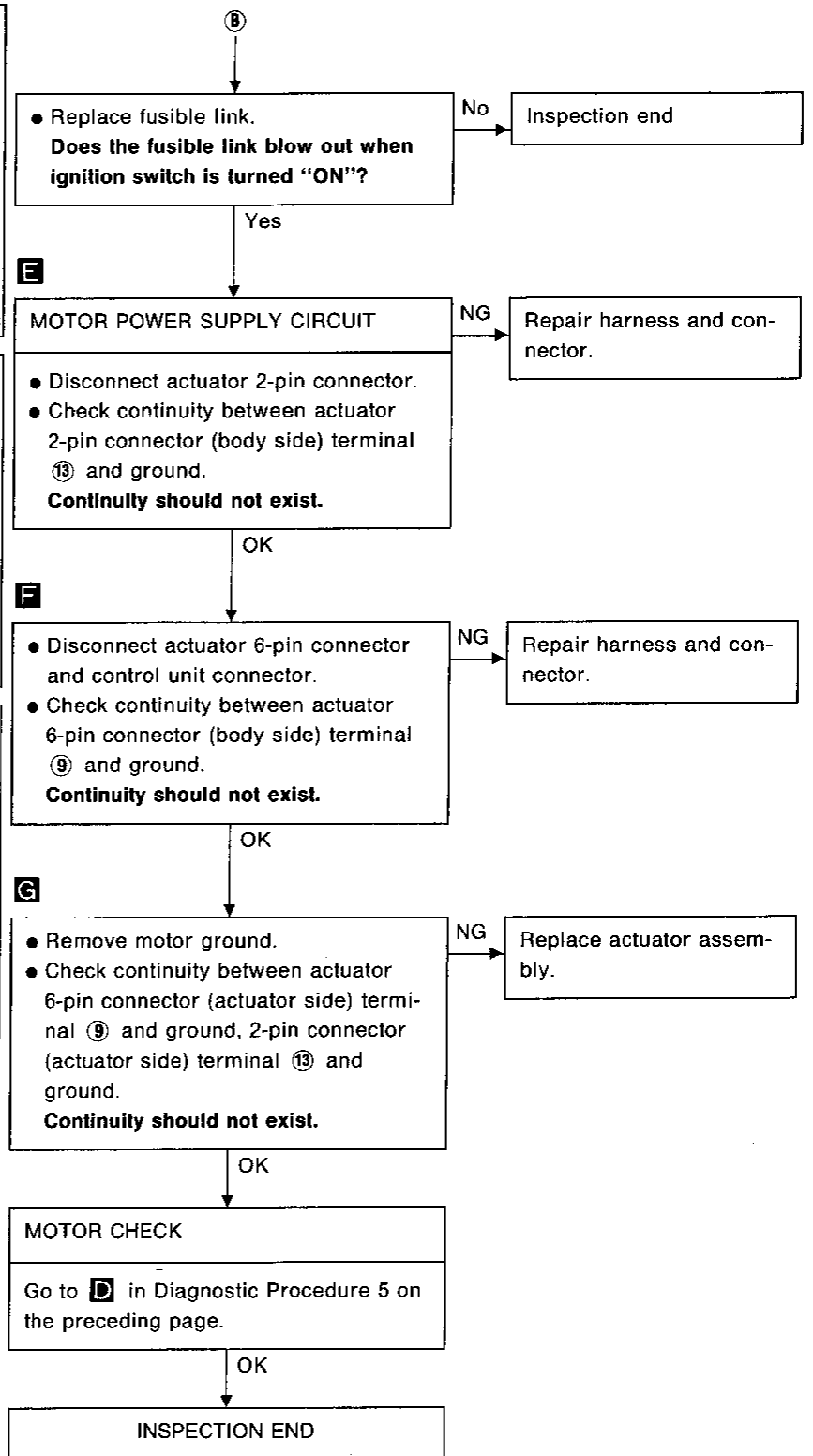
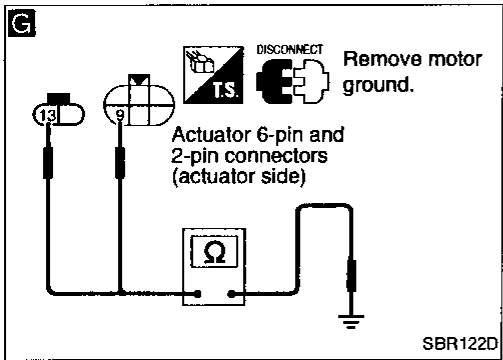
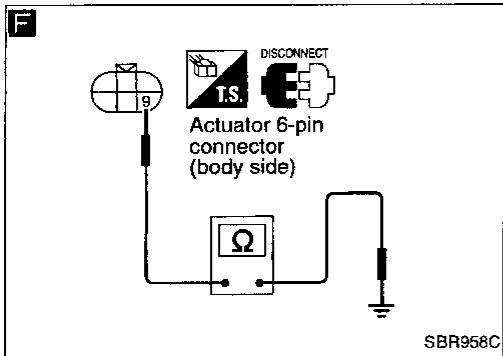
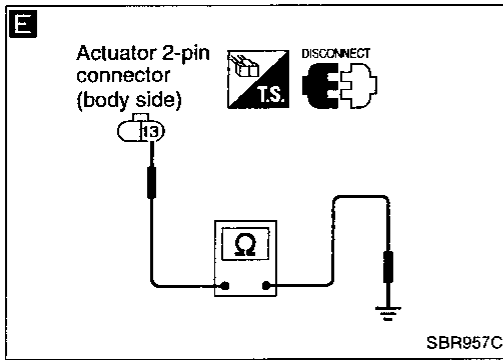

GI

MA

EM

LC

EC

FE

CL

MT

AT

FA

RA

BR

ST

RS

BT

HA

EL

IDX

## Diagnostic Procedure 6

### SOLENOID VALVE RELAY (Malfunction code No. 63)

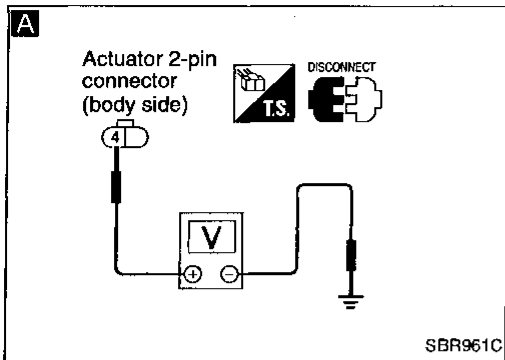

SOLENOID VALVE POWER SUPPLY CHECK

NG → **A** (See next page.)

- Check fusible link **□**. For fusible link layout, refer to POWER SUPPLY ROUTING in EL section.

OK

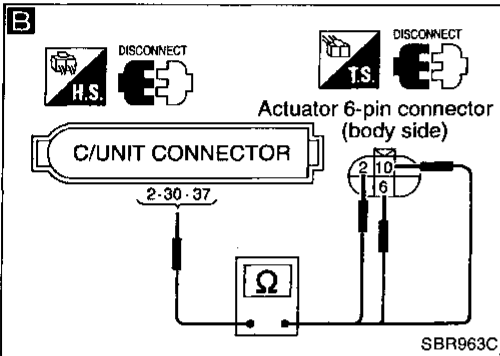

- Disconnect connectors from control unit and actuator. Check terminals for damage or loose connection. Then reconnect connectors.
- Carry out self-diagnosis again.  
**Does warning lamp activate again?**

No → Inspection end

Yes

GROUND CIRCUIT CHECK

NG → Repair harness and connectors.

Refer to CONTROL UNIT GROUND and ACTUATOR GROUND in Ground Circuit Check (BR-43).

OK

**A**

SOLENOID VALVE POWER SUPPLY CHECK

NG → Repair harness and connector.

- Disconnect connectors from actuator.
- Check voltage between actuator 2-pin connector (body side) terminal **④** and ground.  
**Battery voltage should exist.**

OK

**B**

CIRCUIT CHECK

NG → Repair harness and connectors.

- Disconnect control unit connector.
- Check continuity between control unit connector terminals and actuator connector (body side) terminals.

Control unit	Actuator
⑤⑦	⑤
②	②
③⑥	⑩

**Continuity should exist.**

OK

SOLENOID VALVE RELAY CHECK

NG → Replace solenoid valve relay.

Refer to SOLENOID VALVE RELAY in Electrical Components Inspection (BR-62).

OK

**B**

(Go to next page.)



# TROUBLE DIAGNOSES

## Diagnostic Procedure 6 (Cont'd)

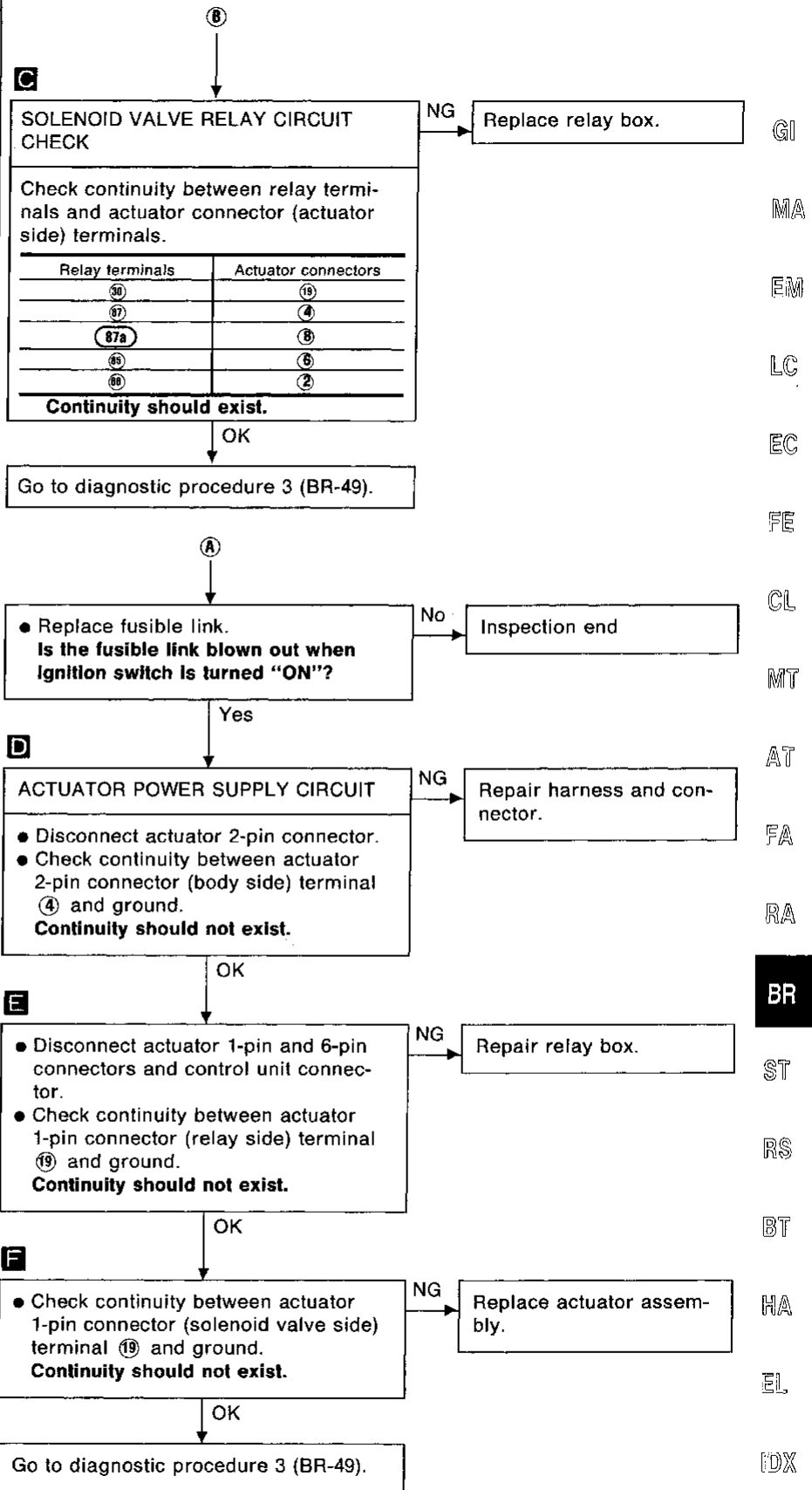
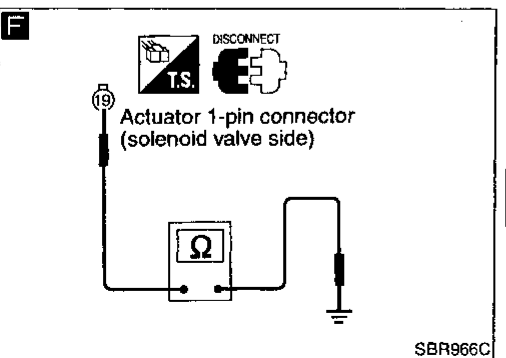
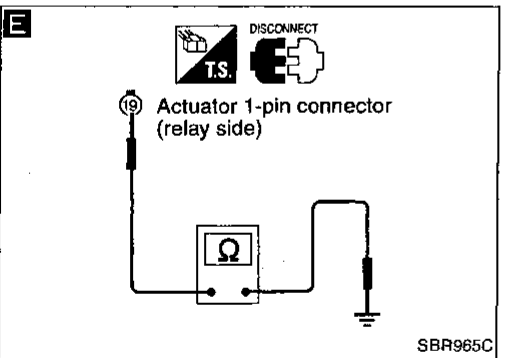
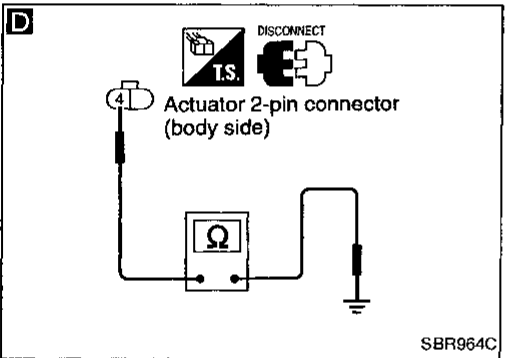
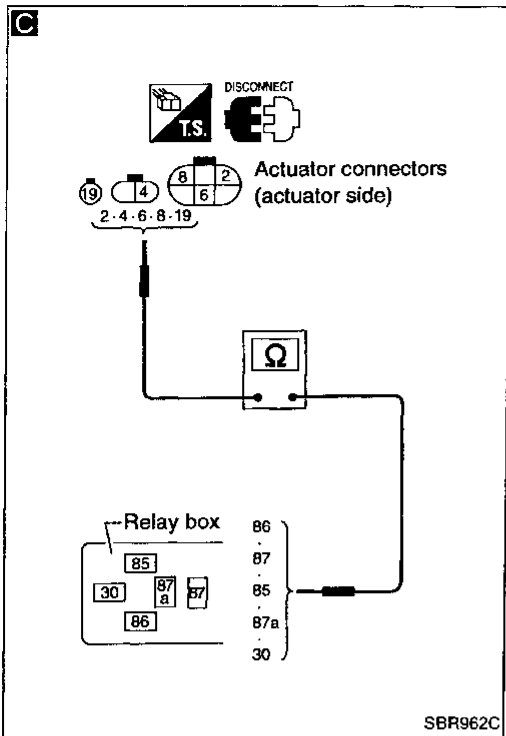

GI  
MA  
EM  
LC  
EC  
FE  
CL  
MT  
AT  
FA  
RA  
BR  
ST  
RS  
BT  
HA  
EL  
FDX

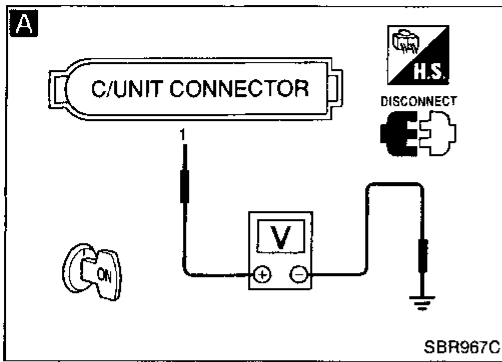

## Diagnostic Procedure 7 POWER SUPPLY (Low voltage) (Malfunction code No. 57)

● Disconnect control unit connectors. Check terminals for damage or connection. Then reconnect connectors.  
● Carry out self-diagnosis again.  
**Does warning lamp activate again?**

No → Inspection end

Yes →

**A**

**CONTROL UNIT POWER SUPPLY CHECK**

● Disconnect control unit connector.  
● Check voltage between control unit connector terminal ① and ground.  
**Battery voltage should exist when ignition switch is turned ON.**

NG → ① (See below.)

OK →

**CONTROL UNIT GROUND CHECK**

● Refer to CONTROL UNIT GROUND in Ground Circuit Check (BR-43).

NG → Repair harness and connectors.

OK →

Replace control unit.

①

Check 10A fuse 15. Refer to POWER SUPPLY ROUTING in EL section.

NG → Replace fuse.

OK →

Check continuity between battery and control unit connector terminal ①.

NG → Repair harness and connectors.

OK →

Check battery. Refer to BATTERY in EL section.

## Diagnostic Procedure 8 CONTROL UNIT (Malfunction code No. 71)

Carry out self-diagnosis after erasing self-diagnostic results (BR-32, 36).

Does warning lamp indicate code No. 71 again?

Yes → Replace control unit.

No →

Inspect the system according to the code No.

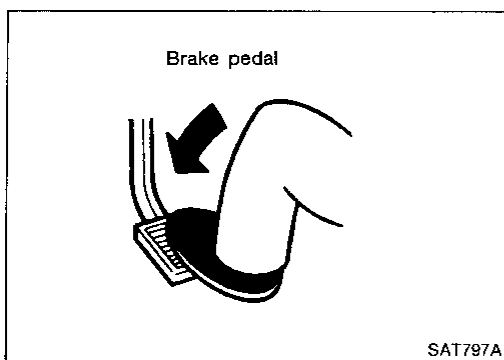

## Diagnostic Procedure 9

### SYMPTOM: Pedal vibration and noise

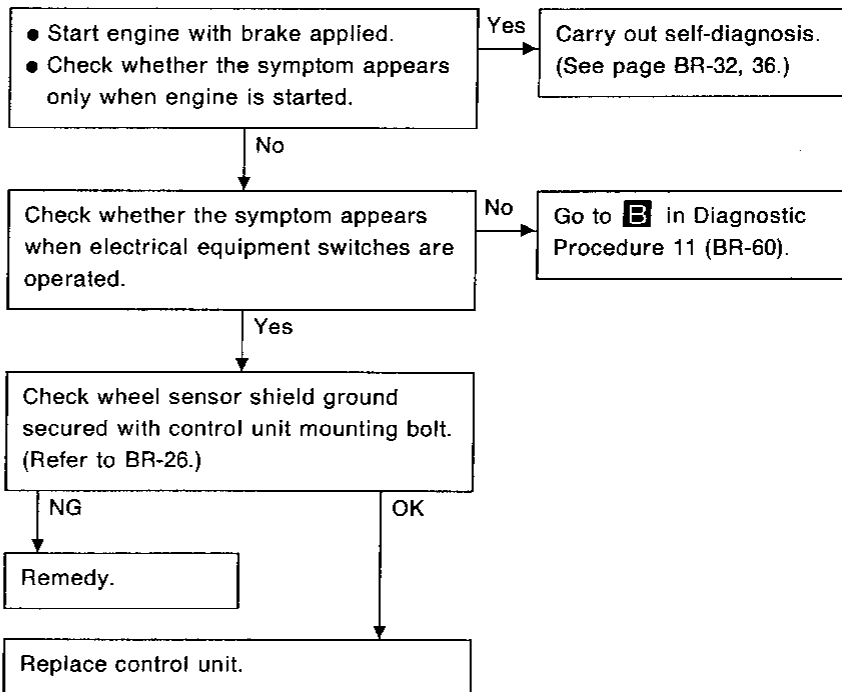

**Note:** ABS may operate and cause vibration under the following conditions.

- Applying brake gradually when shifting or operating clutch.
- Low-friction road
- High speed cornering
- Passing over bumps/potholes
- Engine speed is over 5,000 rpm with vehicle stopped.

GI

MA

EM

LC

EC

FE

CL

MT

AT

FA

RA

BR

ST

RS

BT

HA

EL

IDX

## Diagnostic Procedure 10

**SYMPTOM: Long stopping distance**

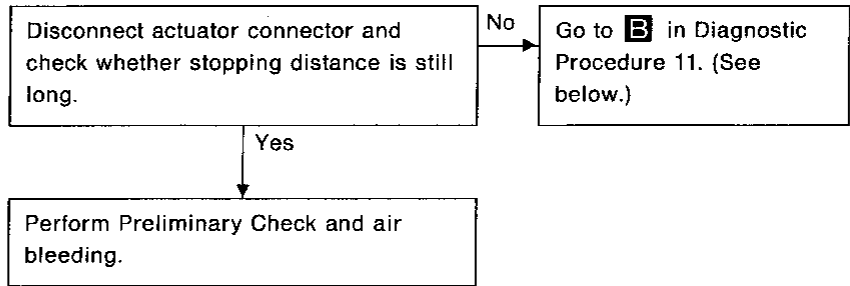

**Note: Stopping distance may be longer than that of vehicles without ABS when road condition is slippery.**

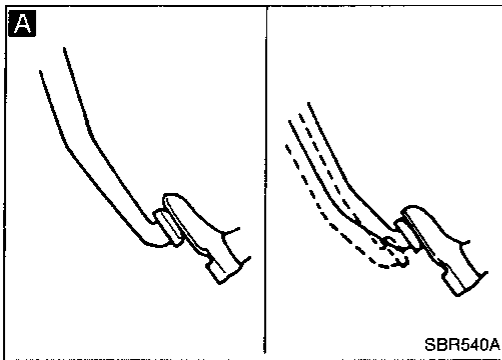

## Diagnostic Procedure 11

**SYMPTOM: Unexpected pedal action**

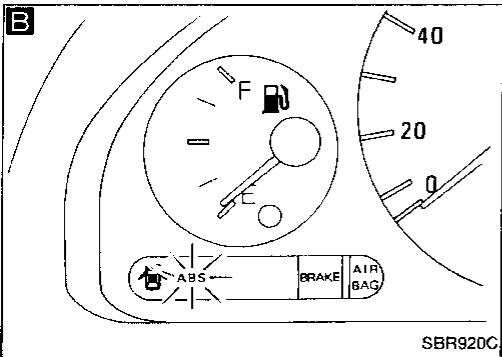
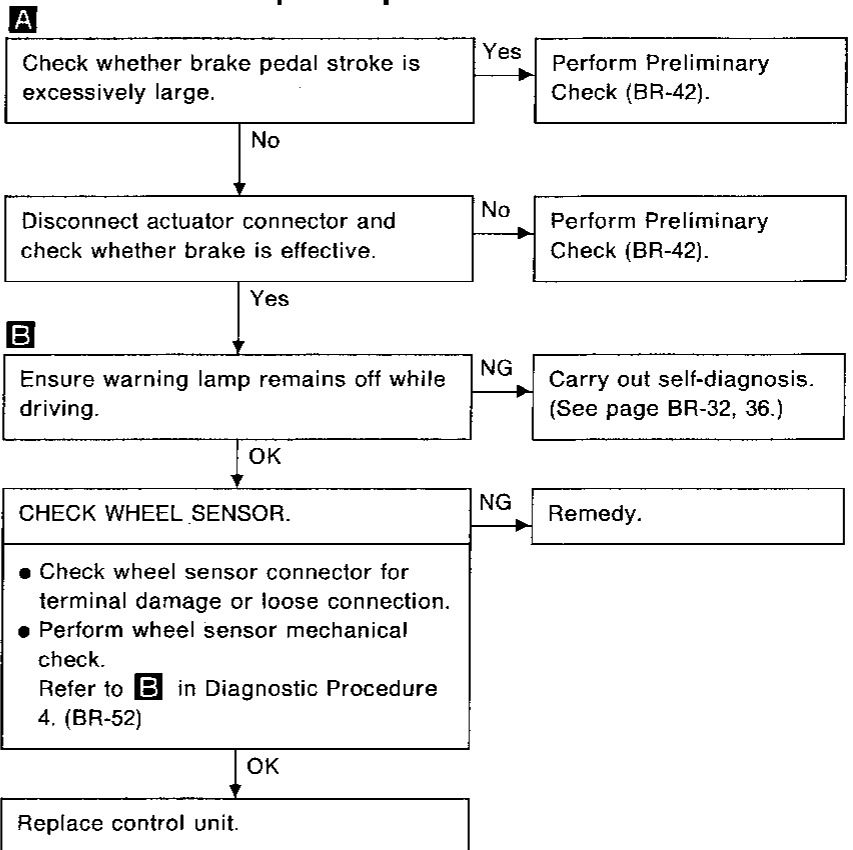

# TROUBLE DIAGNOSES

## Diagnostic Procedure 12

**SYMPTOM: ABS does not work.**

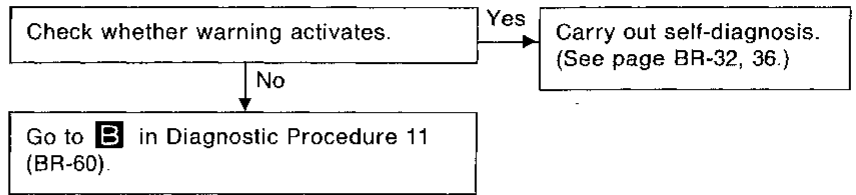

**Note: ABS does not work when vehicle speed is under 10 km/h (6 MPH).**

## Diagnostic Procedure 13

**SYMPTOM: ABS works frequently.**

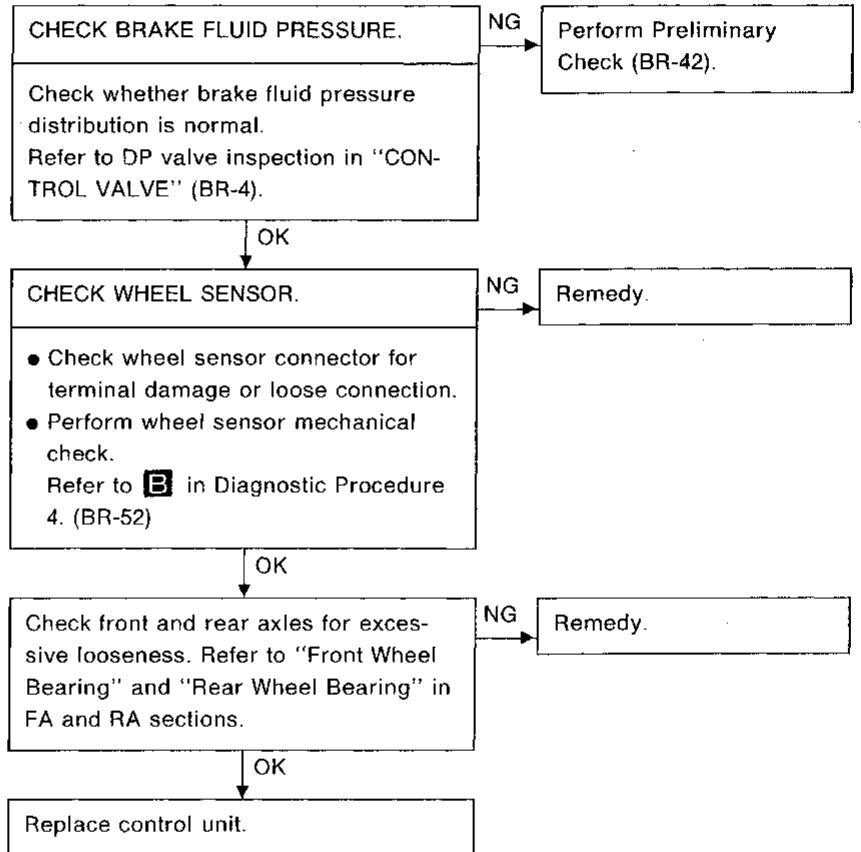

# TROUBLE DIAGNOSES

## Electrical Components Inspection

### WHEEL SENSOR

Check resistance for each sensor.

**Resistance: 0.8 - 1.2 kΩ**

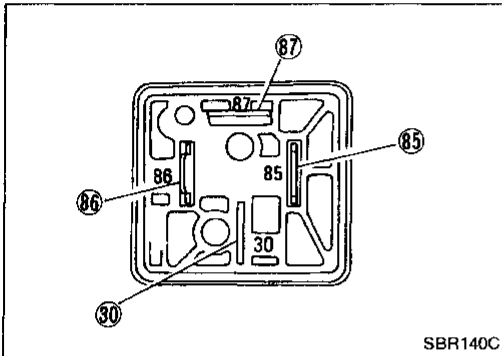

### ACTUATOR MOTOR RELAY

Condition	Continuity existence between terminals ③⑩ and ③⑦
Battery voltage not applied between terminals ③⑤ and ③⑥.	No
Battery voltage applied between terminals ③⑤ and ③⑥.	Yes

**While applying battery voltage to relay terminals, insert fuse into the circuit.**

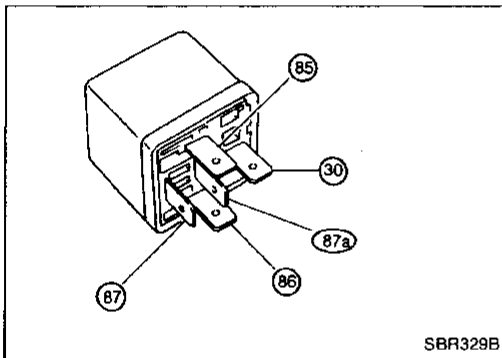

### SOLENOID VALVE RELAY

Condition	Continuity existence between terminals ③⑩ and ③⑦a	Continuity existence between terminals ③⑩ and ③⑦
Battery voltage not applied between terminals ③⑤ and ③⑥.	Yes	No
Battery voltage applied between terminals ③⑤ and ③⑥.	No	Yes

**While applying battery voltage to relay terminals, insert fuse into the circuit.**

# SERVICE DATA AND SPECIFICATIONS (SDS)

## General Specifications

<b>Front brake</b>	
Brake model	CL25VB disc brake
Cylinder bore diameter mm (in)	57.2 (2.252)
Pad mm (in) Length x width x thickness	125.6 x 45.3 x 11 (4.94 x 1.783 x 0.43)
Rotor outer diameter x thick- ness mm (in)	280 x 22 (11.02 x 0.87)
<b>Rear brake</b>	
Brake model	CL9HB disc brake
Cylinder bore diameter mm (in)	33.96 (1.3370)
Pad mm (in) Length x width x thickness	89.1 x 39.5 x 10 (3.508 x 1.555 x 0.39)
Rotor outer diameter x thickness mm (in)	278 x 9 (10.94 x 0.35)

<b>Master cylinder</b>	
Cylinder bore diameter mm (in)	23.81 (15/16)
<b>Control valve</b>	
Valve model	Dual proportioning valve
Split point kPa (kg/cm <sup>2</sup> , psi) x reducing ratio	1,961 (20, 284) x 0.2
<b>Brake booster</b>	
Booster model	M215T
Diaphragm diameter mm (in)	Primary: 230 (9.06) Secondary: 205 (8.07)
Recommended brake fluid	DOT 3

## Inspection and Adjustment

### DISC BRAKE

Brake model	CL25VB	CL9HB
Pad wear limit mm (in) Minimum thickness	2.0 (0.079)	1.5 (0.059)
Rotor repair limit mm (in) Minimum thickness	20.0 (0.787)	8 (0.31)

### PARKING BRAKE

Type	Center lever
Number of notches [under force of 196 N (20 kg, 44 lb)]	10 - 11
Number of notches when warning lamp switch comes on	1

### BRAKE PEDAL

Free height "H" mm (in) M/T	158 - 165 (6.22 - 6.50)
A/T	167 - 174 (6.57 - 6.85)
Depressed height "D" mm (in) [under force of 490 N (50 kg, 110 lb) with engine running]	M/T: 70 (2.76) A/T: 75 (2.95)
Pedal free play "A" mm (in)	1 - 3 (0.04 - 0.12)
Clearance "C" between pedal stopper and threaded end of stop lamp switch or ASCD switch mm (in)	0.3 - 1.0 (0.012 - 0.039)