

SECTION **WCS**

WARNING CHIME SYSTEM

A
B
C

CONTENTS

<p>BASIC INSPECTION 3</p> <p>DIAGNOSIS AND REPAIR WORKFLOW 3</p> <p style="padding-left: 20px;">Work Flow3</p> <p>FUNCTION DIAGNOSIS 5</p> <p>WARNING CHIME SYSTEM 5</p> <p>WARNING CHIME SYSTEM5</p> <p style="padding-left: 20px;">WARNING CHIME SYSTEM : System Diagram5</p> <p style="padding-left: 20px;">WARNING CHIME SYSTEM : System Description5</p> <p style="padding-left: 20px;">WARNING CHIME SYSTEM : Component Parts Location6</p> <p style="padding-left: 20px;">WARNING CHIME SYSTEM : Component Description6</p> <p>LIGHT REMINDER WARNING CHIME7</p> <p style="padding-left: 20px;">LIGHT REMINDER WARNING CHIME : System Diagram7</p> <p style="padding-left: 20px;">LIGHT REMINDER WARNING CHIME : System Description7</p> <p style="padding-left: 20px;">LIGHT REMINDER WARNING CHIME : Component Parts Location8</p> <p style="padding-left: 20px;">LIGHT REMINDER WARNING CHIME : Component Description8</p> <p>SEAT BELT WARNING CHIME8</p> <p style="padding-left: 20px;">SEAT BELT WARNING CHIME : System Diagram9</p> <p style="padding-left: 20px;">SEAT BELT WARNING CHIME : System Description9</p> <p style="padding-left: 20px;">SEAT BELT WARNING CHIME : Component Parts Location10</p> <p style="padding-left: 20px;">SEAT BELT WARNING CHIME : Component Description10</p> <p>PARKING BRAKE RELEASE WARNING CHIME.... 10</p> <p style="padding-left: 20px;">PARKING BRAKE RELEASE WARNING CHIME : System Diagram 11</p>	<p style="padding-left: 20px;">PARKING BRAKE RELEASE WARNING CHIME : System Description11</p> <p style="padding-left: 20px;">PARKING BRAKE RELEASE WARNING CHIME : Component Parts Location12</p> <p style="padding-left: 20px;">PARKING BRAKE RELEASE WARNING CHIME : Component Description12</p> <p>DIAGNOSIS SYSTEM (UNIFIED METER AND A/C AMP.)13</p> <p style="padding-left: 20px;">CONSULT-III Function (METER/M&A)13</p> <p>DIAGNOSIS SYSTEM (BCM)17</p> <p>COMMON ITEM17</p> <p style="padding-left: 20px;">COMMON ITEM : CONSULT-III Function (BCM - COMMON ITEM)17</p> <p>BUZZER18</p> <p style="padding-left: 20px;">BUZZER : CONSULT-III Function (BCM - BUZZER)18</p> <p>COMPONENT DIAGNOSIS20</p> <p>POWER SUPPLY AND GROUND CIRCUIT20</p> <p>COMBINATION METER20</p> <p style="padding-left: 20px;">COMBINATION METER : Diagnosis Procedure20</p> <p>UNIFIED METER AND A/C AMP.20</p> <p style="padding-left: 20px;">UNIFIED METER AND A/C AMP. : Diagnosis Procedure20</p> <p>BCM (BODY CONTROL MODULE)21</p> <p style="padding-left: 20px;">BCM (BODY CONTROL MODULE) : Diagnosis Procedure21</p> <p>METER BUZZER CIRCUIT23</p> <p style="padding-left: 20px;">Description23</p> <p style="padding-left: 20px;">Component Function Check23</p> <p style="padding-left: 20px;">Diagnosis Procedure23</p> <p>SEAT BELT BUCKLE SWITCH SIGNAL CIRCUIT24</p>
--	---

D
E
F
G
H
I
J
K
L
M
WCS

Description	24	DTC Index	95
Component Function Check	24	SYMPTOM DIAGNOSIS	97
Diagnosis Procedure	24	THE PARKING BRAKE RELEASE WARNING	
Component Inspection	25	CONTINUES SOUNDING, OR DOES NOT	
WARNING CHIME SYSTEM	26	SOUND	97
Wiring Diagram — WARNING CHIME —	26	Description	97
ECU DIAGNOSIS	30	Diagnosis Procedure	97
COMBINATION METER	30	THE LIGHT REMINDER WARNING DOES	
Reference Value	30	NOT SOUND	98
Wiring Diagram - METER -	33	Description	98
Fail Safe	42	Diagnosis Procedure	98
DTC Index	43	THE SEAT BELT WARNING CONTINUES	
UNIFIED METER AND A/C AMP.	44	SOUNDING, OR DOES NOT SOUND	99
Reference Value	44	Description	99
Wiring Diagram - METER -	51	Diagnosis Procedure	99
Fail Safe	60	PRECAUTION	100
DTC Index	61	PRECAUTIONS	100
BCM (BODY CONTROL MODULE)	63	Precaution for Supplemental Restraint System	
Reference Value	63	(SRS) "AIR BAG" and "SEAT BELT PRE-TEN-	
Wiring Diagram - BCM -	86	SIONER"	100
Fail Safe	91		
DTC Inspection Priority Chart	93		

DIAGNOSIS AND REPAIR WORKFLOW

< BASIC INSPECTION >

BASIC INSPECTION

DIAGNOSIS AND REPAIR WORKFLOW

Work Flow

INFOID:000000001606803

OVERALL SEQUENCE

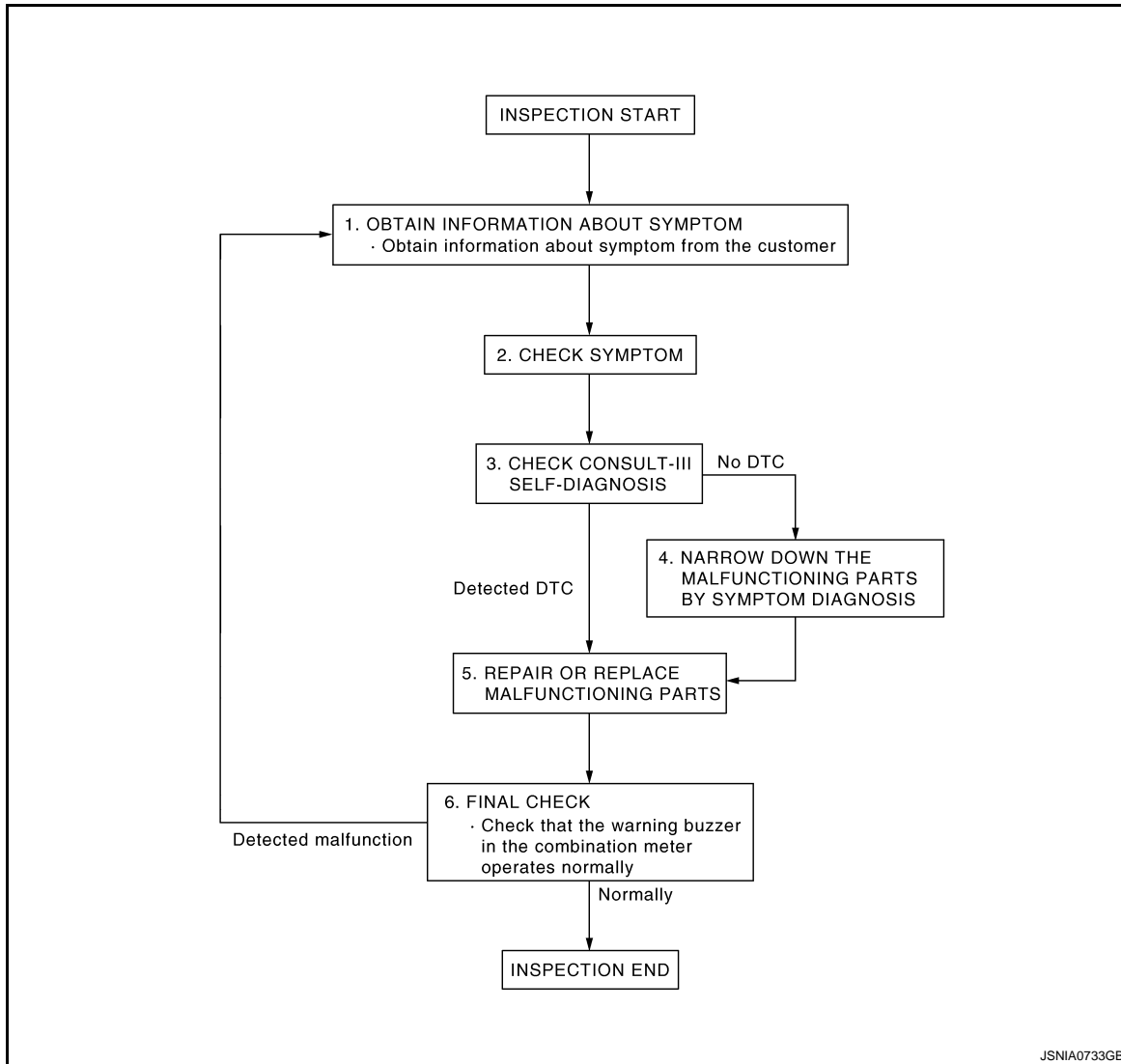

DETAILED FLOW

1. OBTAIN INFORMATION ABOUT SYMPTOM

Interview the customer to obtain as much information as possible about the conditions and environment under which the malfunction occurred.

>> GO TO 2.

2. CHECK SYMPTOM

- Check the symptom based on the information obtained from the customer.
- Check that any other malfunctions are present.

>> GO TO 3.

3. CHECK CONSULT-III SELF-DIAGNOSIS RESULTS

WCS

DIAGNOSIS AND REPAIR WORKFLOW

< BASIC INSPECTION >

Connect CONSULT-III and perform "Self Diagnostic Result" of "METER/M&A". Refer to [MWI-37, "CONSULT-III Function \(METER/M&A\)"](#).

Are self-diagnosis results normal?

YES >> GO TO 4.

NO >> GO TO 5.

4. NARROW DOWN MALFUNCTIONING PARTS BY SYMPTOM DIAGNOSIS

Perform symptom diagnosis and narrow down the malfunctioning parts.

>> GO TO 5.

5. REPAIR OR REPLACE MALFUNCTIONING PARTS

Repair or replace malfunctioning parts.

NOTE:

If DTC is displayed, erase DTC after repair or replace malfunctioning parts.

>> GO TO 6.

6. FINAL CHECK

Check that the warning buzzer in the combination meter operates normally.

Does it operate normally?

YES >> INSPECTION END

NO >> GO TO 1.

WARNING CHIME SYSTEM

< FUNCTION DIAGNOSIS >

FUNCTION DIAGNOSIS

WARNING CHIME SYSTEM

WARNING CHIME SYSTEM

WARNING CHIME SYSTEM : System Diagram

INFOID:000000001606804

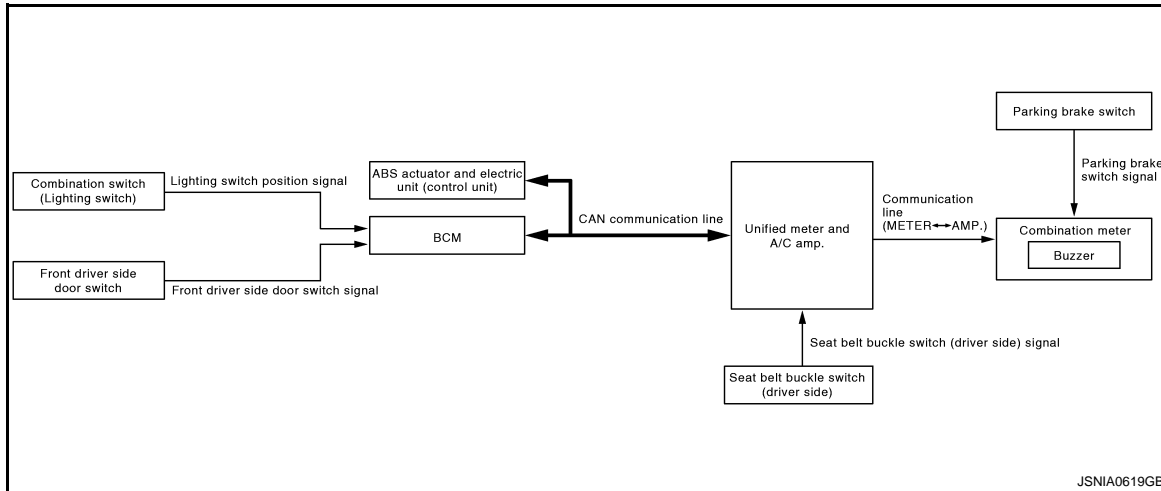

WARNING CHIME SYSTEM : System Description

INFOID:000000001606805

COMBINATION METER

- The buzzer (1) for warning chime system is installed in the combination meter.
- The buzzer sounds when the combination meter receives buzzer output signal from each unit through unified meter and A/C amp.

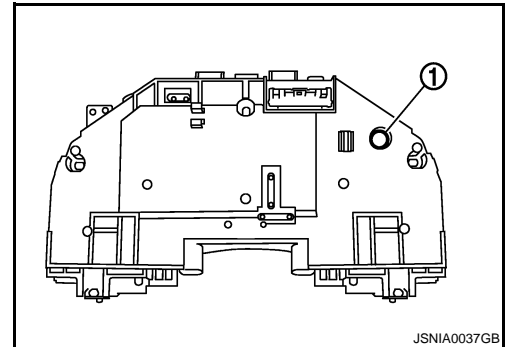

UNIFIED METER AND A/C AMP.

The unified meter and A/C amp. transmits the buzzer output signal received from BCM with CAN communication line to the combination meter.

BCM

BCM receives signals from various units and transmits a buzzer output signal to the unified meter and A/C amp. with CAN communication line if it judges that the warning buzzer should be activated.

BCM warning function list

Warning functions	Signal name
Light reminder warning chime	<ul style="list-style-type: none"> • Lighting switch position signal • Driver side door switch signal
Seat belt warning chime	<ul style="list-style-type: none"> • Ignition switch signal • Seat belt buckle switch (driver side) signal

A
B
C
D
E
F
G
H
I
J
K
L
M
O
P

WCS

WARNING CHIME SYSTEM

< FUNCTION DIAGNOSIS >

WARNING CHIME SYSTEM : Component Parts Location

INFOID:000000001606806

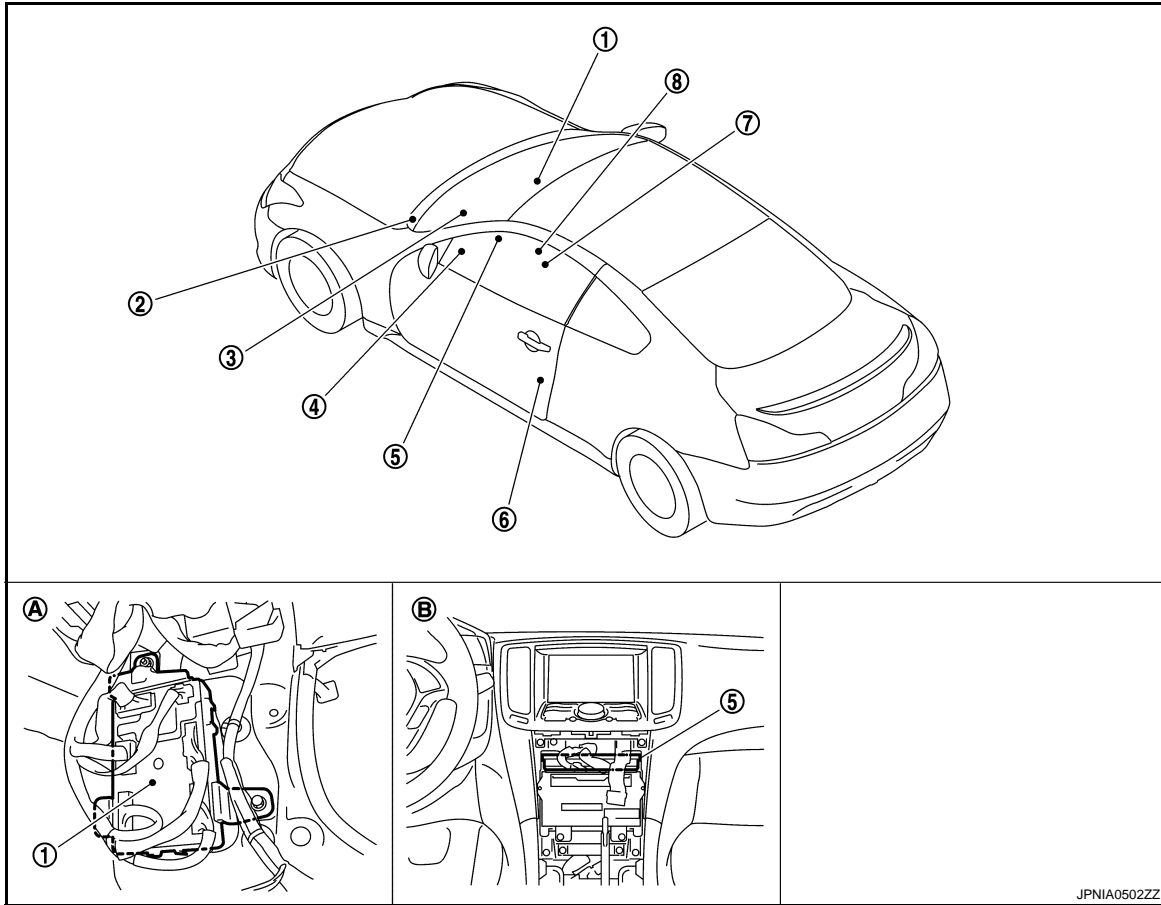

JPNIA0502ZZ

- | | | |
|--|--------------------------------------|----------------------------------|
| 1. BCM | 2. Parking brake switch (A/T models) | 3. Combination meter |
| 4. Combination switch (Lighting switch) | 5. Unified meter and A/C amp. | 6. Front driver side door switch |
| 7. Seat belt buckle switch (driver side) | 8. Parking brake switch (M/T models) | |
| A. Dash side lower (passenger side) | B. Behind cluster lid C (back) | |

WARNING CHIME SYSTEM : Component Description

INFOID:000000001606807

Unit	Description
Combination meter	<ul style="list-style-type: none"> Receives a buzzer output signal from the unified meter and A/C amp. and sounds the buzzer. Judges whether the parking brake is released from the vehicle speed signal received from the unified meter and A/C amp. with CAN communication line and the parking brake switch signal from the parking brake switch, and sounds the buzzer if necessary.
Unified meter and A/C amp.	<ul style="list-style-type: none"> Receives the seat belt buckle switch signal from the seat belt buckle switch and transmits it to BCM with CAN communication line. Receives a buzzer output signal from BCM with CAN communication line and transmits it to the combination meter by means of communication line.
BCM	Transmits signals provided by various units to the unified meter and A/C amp. with CAN communication line.
ABS actuator and electric unit (control unit)	Transmits the vehicle speed signal to BCM with CAN communication line.
Seat belt buckle switch (driver side)	Transmits a seat belt buckle switch (driver side) signal to the unified meter and A/C amp.
Combination switch (Lighting switch)	Transmits the lighting switch position signal to BCM.

WARNING CHIME SYSTEM

< FUNCTION DIAGNOSIS >

Unit	Description
Front driver side door switch	Transmits the front driver side door switch signal to BCM.
Parking brake switch	Refer to MWI-61, "Description" .

LIGHT REMINDER WARNING CHIME

LIGHT REMINDER WARNING CHIME : System Diagram

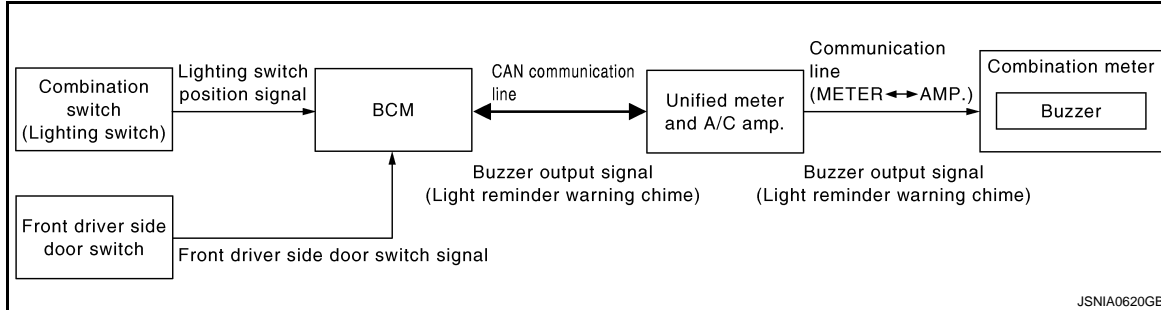

LIGHT REMINDER WARNING CHIME : System Description

INFOID:000000001606809

DESCRIPTION

With ignition switch in OFF or ACC position, front driver side door open, and lighting switch in 1ST or 2ND position, the light warning chime will sound.

- BCM detects ignition switch in OFF or ACC position, driver side door switch ON, and lighting switch in 1ST or 2ND position. And then transmits buzzer output signal (light reminder warning chime) to unified meter and A/C amp. with CAN communication line.
- Unified meter and A/C amp. transmits buzzer output signal (light reminder warning chime) to combination meter with communication line.
- When combination meter receives buzzer output signal (light reminder warning chime), it sounds the buzzer.

WARNING OPERATION CONDITIONS

If all of the following conditions are fulfilled.

- Lighting switch is at 1st or 2nd position
- Ignition switch is at OFF or ACC
- Front driver side door switch is ON

WARNING CANCEL CONDITIONS

Warning is canceled if any of the following conditions is fulfilled.

- Lighting switch OFF
- Ignition switch ON
- Front driver side door switch is OFF

A
B
C
D
E
F
G
H
I
J
K
L
M
O
P

WCS

WARNING CHIME SYSTEM

< FUNCTION DIAGNOSIS >

LIGHT REMINDER WARNING CHIME : Component Parts Location

INFOID:000000001697929

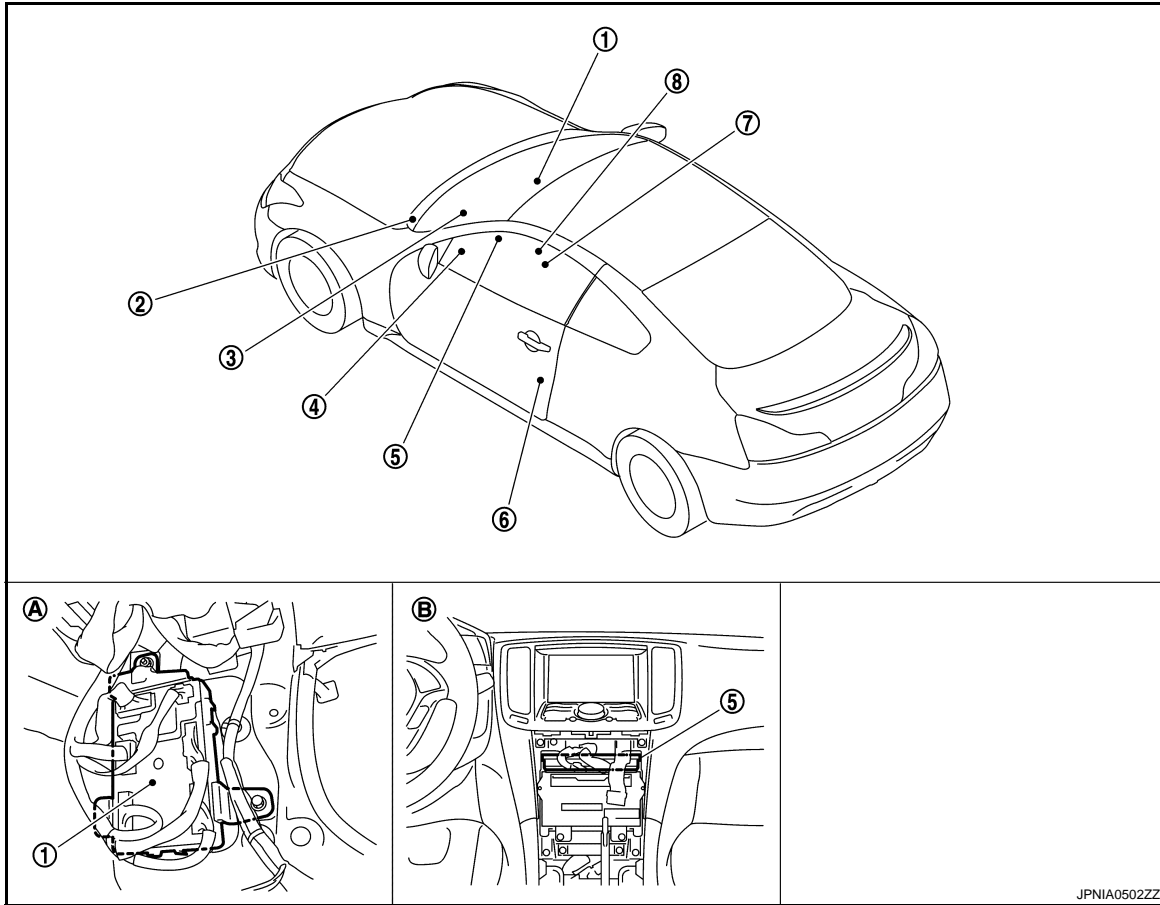

JPNIA0502ZZ

- | | | |
|--|--------------------------------------|----------------------------------|
| 1. BCM | 2. Parking brake switch (A/T models) | 3. Combination meter |
| 4. Combination switch (Lighting switch) | 5. Unified meter and A/C amp. | 6. Front driver side door switch |
| 7. Seat belt buckle switch (driver side) | 8. Parking brake switch (M/T models) | |
| A. Dash side lower (passenger side) | B. Behind cluster lid C (back) | |

LIGHT REMINDER WARNING CHIME : Component Description

INFOID:0000000001606811

Unit	Description
Combination meter	Receives a buzzer output signal from the unified meter and A/C amp. and sounds the buzzer.
Unified meter and A/C amp.	Receives a buzzer output signal from BCM via CAN communication line and transmits it to the combination meter by means of communication line.
BCM	Judges the light warning chime conditions from the signals provided by various switches and transmits a buzzer output signal to the unified meter and A/C amp. via CAN communication line if necessary.
Combination switch (Lighting switch)	Transmits the lighting switch position signal to BCM.
Front driver side door switch	Transmits the front driver side door switch signal to BCM.

SEAT BELT WARNING CHIME

WARNING CHIME SYSTEM

< FUNCTION DIAGNOSIS >

SEAT BELT WARNING CHIME : System Diagram

INFOID:000000001606812

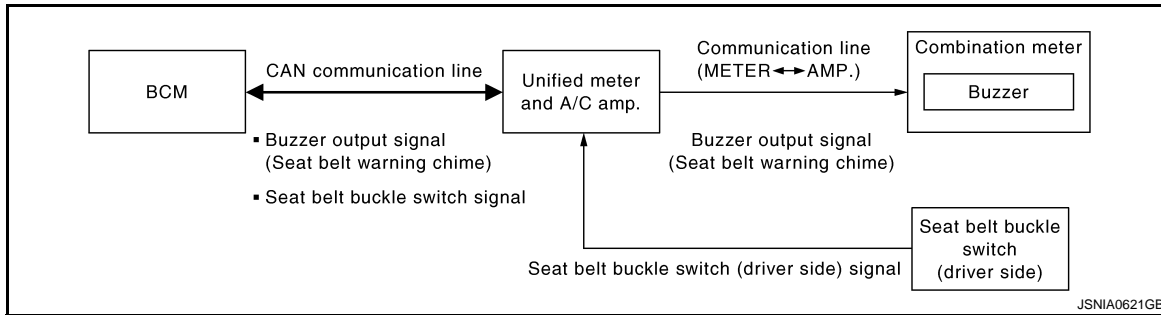

SEAT BELT WARNING CHIME : System Description

INFOID:000000001606813

DESCRIPTION

With ignition switch turned ON and driver seat belt unfastened, seat belt warning chime will sound for approximately 6 seconds.

- BCM receives seat belt buckle switch signal from unified meter and A/C amp. with CAN communication line.
- BCM detects ignition switch turned ON and seat belt buckle switch (driver side) ON. And then transmits buzzer output signal (seat belt warning chime) to unified meter and A/C amp. with CAN communication line.
- Unified meter and A/C amp. transmits buzzer output signal (seat belt warning chime) to combination meter with communication line.
- When combination meter receives buzzer output signal (seat belt warning chime), it sounds the buzzer.

WARNING OPERATION CONDITIONS

If all of the following conditions are fulfilled.

- Ignition switch OFF→ON
- Seat buckle switch (driver side) is ON (driver seat belt unfastened)

WARNING CANCEL CONDITIONS

Warning is canceled if any of the following conditions is fulfilled.

- Ignition switch OFF
- Seat buckle switch (driver side) is OFF (driver seat belt fastened)

A
B
C
D
E
F
G
H
I
J
K
L
M

WCS

O
P

WARNING CHIME SYSTEM

< FUNCTION DIAGNOSIS >

SEAT BELT WARNING CHIME : Component Parts Location

INFOID:000000001697930

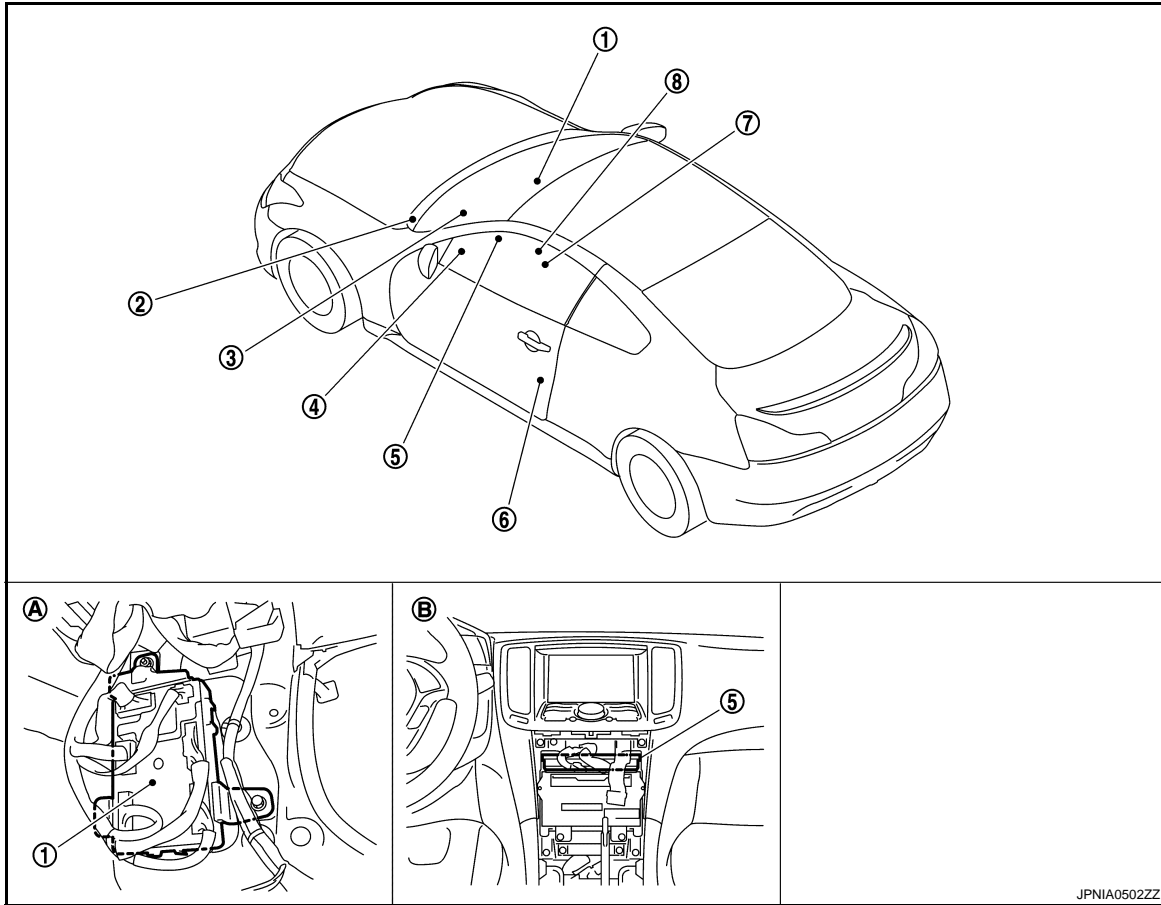

JPNIA0502ZZ

- | | | |
|--|--------------------------------------|----------------------------------|
| 1. BCM | 2. Parking brake switch (A/T models) | 3. Combination meter |
| 4. Combination switch (Lighting switch) | 5. Unified meter and A/C amp. | 6. Front driver side door switch |
| 7. Seat belt buckle switch (driver side) | 8. Parking brake switch (M/T models) | |
| A. Dash side lower (passenger side) | B. Behind cluster lid C (back) | |

SEAT BELT WARNING CHIME : Component Description

INFOID:000000001606815

Unit	Description
Combination meter	Receives a buzzer output signal from the unified meter and A/C amp. and sounds the buzzer.
Unified meter and A/C amp.	<ul style="list-style-type: none"> Receives the seat belt buckle switch (driver side) signal from the seat belt buckle switch (driver side) and transmits it to BCM via CAN communication line. Receives a buzzer output signal from BCM via CAN communication line and transmits it to the combination meter by means of communication line.
BCM	Judges the seat belt warning chime condition from the seat belt buckle switch signal received from the unified meter and A/C amp. and transmits a buzzer output signal to the unified meter and A/C amp via CAN communication line if necessary.
Seat belt buckle switch (driver side)	Refer to WCS-24. "Description" .

PARKING BRAKE RELEASE WARNING CHIME

WARNING CHIME SYSTEM

< FUNCTION DIAGNOSIS >

PARKING BRAKE RELEASE WARNING CHIME : System Diagram

INFOID:000000001606816

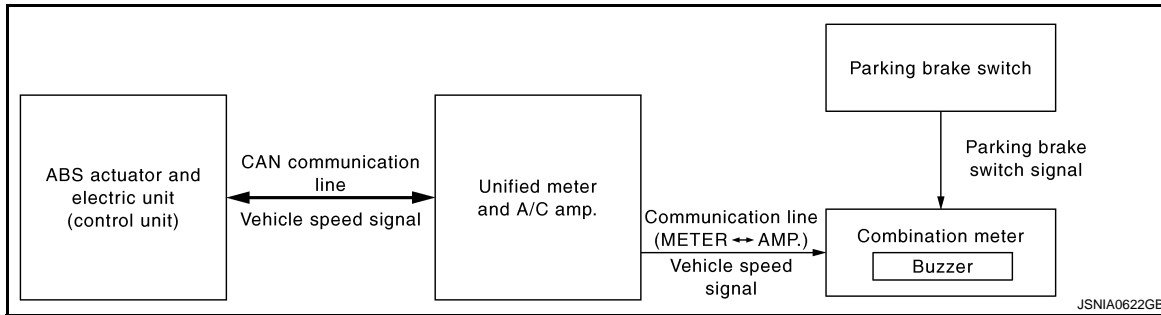

PARKING BRAKE RELEASE WARNING CHIME : System Description

INFOID:000000001606817

DESCRIPTION

- The unified meter and A/C amp. receives the vehicle speed signal from the ABS actuator and electric unit (control unit) via CAN communication line and transmits it to the combination meter by means of communication line.
- The combination meter judges whether the parking brake is released from the vehicle speed signal received from the unified meter and A/C amp. and the parking brake switch signal from the parking brake switch, and sounds the warning buzzer if necessary.

WARNING OPERATION CONDITIONS

If all of the following conditions are fulfilled.

- Vehicle speed is 7 km/h (4.3 MPH) or higher
- Parking brake switch ON

WARNING CANCEL CONDITIONS

Warning is canceled if any of the following conditions is fulfilled.

- Vehicle speed is approximately 3 km/h (1.9 MPH) or less
- Parking brake switch OFF

A
B
C
D
E
F
G
H
I
J
K
L
M
O
P

WCS

WARNING CHIME SYSTEM

< FUNCTION DIAGNOSIS >

PARKING BRAKE RELEASE WARNING CHIME : Component Parts Location

INFOID:000000001697931

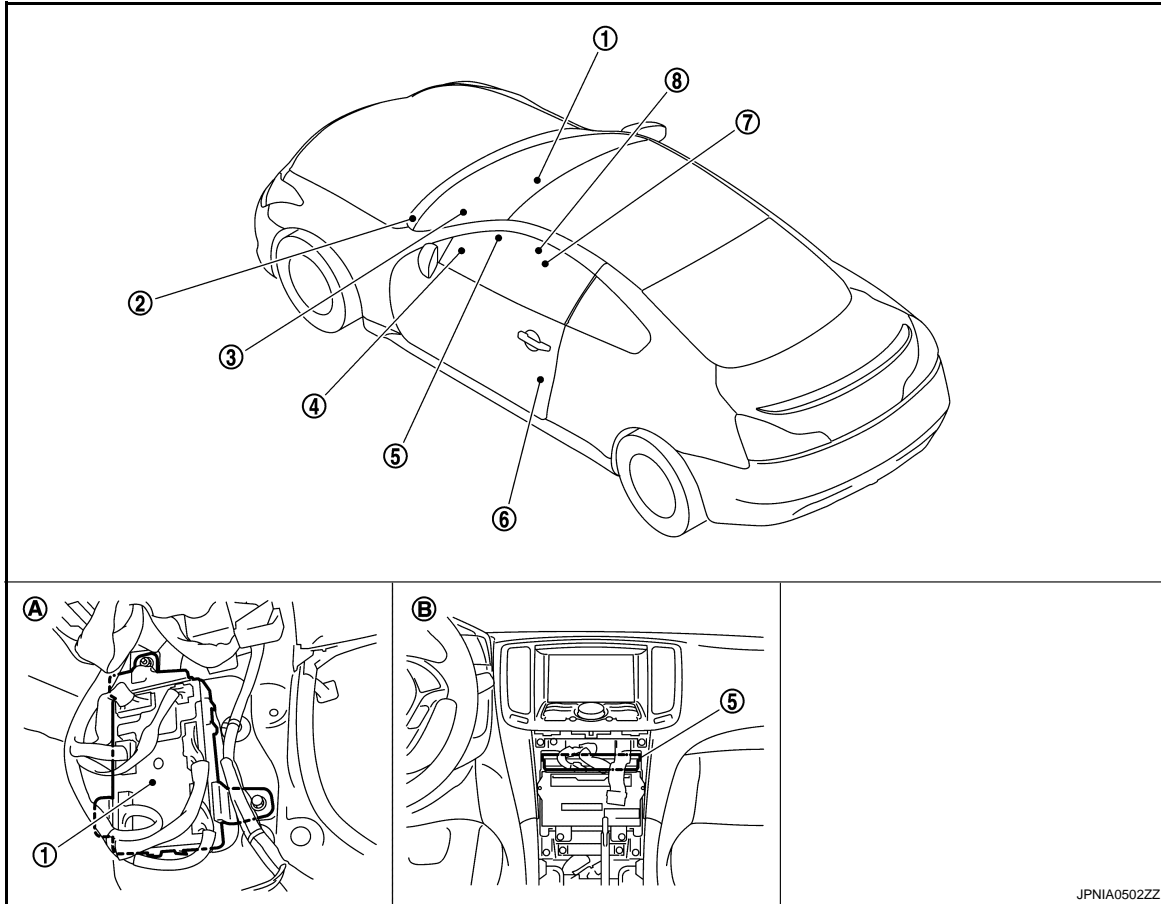

JPNIA0502ZZ

- | | | |
|--|--------------------------------------|----------------------------------|
| 1. BCM | 2. Parking brake switch (A/T models) | 3. Combination meter |
| 4. Combination switch (Lighting switch) | 5. Unified meter and A/C amp. | 6. Front driver side door switch |
| 7. Seat belt buckle switch (driver side) | 8. Parking brake switch (M/T models) | |
| A. Dash side lower (passenger side) | B. Behind cluster lid C (back) | |

PARKING BRAKE RELEASE WARNING CHIME : Component Description

INFOID:000000001606819

Unit	Description
Combination meter	Judges whether the parking brake is released from the vehicle speed signal received from the unified meter and A/C amp. via CAN communication line and the parking brake switch signal from the parking brake switch, and sounds the buzzer if necessary.
Unified meter and A/C amp.	Receives a vehicle speed signal from ABS actuator and electric unit (control unit) via CAN communication line and transmits it to the combination meter by means of communication line.
ABS actuator and electric unit (control unit)	Transmits the vehicle speed signal to combination meter via CAN communication line.
Parking brake switch	Refer to MWI-61, "Description" .

DIAGNOSIS SYSTEM (UNIFIED METER AND A/C AMP.)

< FUNCTION DIAGNOSIS >

DIAGNOSIS SYSTEM (UNIFIED METER AND A/C AMP.)

CONSULT-III Function (METER/M&A)

INFOID:000000001683784

CONSULT-III APPLICATION ITEMS

CONSULT-III can perform the following diagnosis modes with CAN communication with the unified meter and A/C amp.

System	Diagnosis mode	Description
METER/M&A	Self Diagnostic Result	Unified meter and A/C amp. checks the conditions and displays memorized error.
	Data Monitor	Displays unified meter and A/C amp. input/output data in real time.

SELF DIAG RESULT

Refer to [MWI-100, "DTC Index"](#).

DATA MONITOR

Display Item List

X: Applicable

Display item [Unit]	MAIN SIGNALS	Description
SPEED METER [km/h]	X	Value of vehicle speed signal received from ABS actuator and electric unit (control unit) with CAN communication line. NOTE: 655.35 is displayed when the malfunction signal is received.
SPEED OUTPUT [km/h]	X	Vehicle speed signal value transmitted to other units with CAN communication line. NOTE: 655.35 is displayed when the malfunction signal is received.
ODO OUTPUT [km]		Odometer signal value transmitted to other units with CAN communication line.
TACHO METER [rpm]	X	Value of the engine speed signal received from ECM with CAN communication line. NOTE: 8191.875 is displayed when the malfunction signal is received.
FUEL METER [L]	X	Fuel level indicated on combination meter.
W TEMP METER [°C]	X	Value of engine coolant temperature signal received from ECM with CAN communication line. NOTE: 215 is displayed when the malfunction signal is input.
ABS W/L [On/Off]		Status of ABS warning lamp judged from ABS warning lamp signal received from ABS actuator and electric unit (control unit) with CAN communication line.
VDC/TCS IND [On/Off]		Status of VDC OFF indicator lamp judged from VDC OFF indicator lamp signal received from ABS actuator and electric unit (control unit) with CAN communication line.
SLIP IND [On/Off]		Status of SLIP indicator lamp judged from slip indicator lamp signal received from ABS actuator and electric unit (control unit) with CAN communication line.
BRAKE W/L [On/Off]		Status of brake warning lamp judged from brake warning lamp signal received from ABS actuator and electric unit (control unit) with CAN communication line. NOTE: Displays "Off" if the brake warning lamp is illuminated when the valve check starts, the parking brake switch is turned ON or the brake fluid level switch is turned ON.
DOOR W/L [On/Off]		Status of door warning judged from door switch signal received from BCM with CAN communication line.
TRUNK/GLAS-H [On/Off]		Status of trunk warning judged from trunk switch signal received from BCM with CAN communication line.

DIAGNOSIS SYSTEM (UNIFIED METER AND A/C AMP.)

< FUNCTION DIAGNOSIS >

Display item [Unit]	MAIN SIGNALS	Description
HI-BEAM IND [On/Off]		Status of high beam indicator lamp judged from high beam request signal received from BCM with CAN communication line.
TURN IND [On/Off]		Status of turn indicator lamp judged from turn indicator signal received from BCM with CAN communication line.
FR FOG IND [On/Off]		Status of front fog light indicator lamp judged from front fog light request signal received from BCM with CAN communication line.
RR FOG IND [Off]		This item is displayed, but cannot be monitored.
LIGHT IND [On/Off]		Status of light indicator lamp judged from position light request signal received from BCM with CAN communication line.
OIL W/L [On/Off]		Status of oil pressure warning lamp judged from oil pressure switch signal received from IPDM E/R with CAN communication line.
MIL [On/Off]		Status of malfunction indicator lamp judged from malfunctioning indicator lamp signal received from ECM with CAN communication line.
GLOW IND [On/Off]		This item is displayed, but cannot be monitored.
C-ENG2 W/L [On/Off]		This item is displayed, but cannot be monitored.
CRUISE IND [On/Off]		Status of CRUISE indicator judged from ASCD status signal received from ECM with CAN communication line.
SET IND [On/Off]		Status of SET indicator judged from ASCD SET indicator signal received from ECM with CAN communication line.
CRUISE W/L [On/Off]		Status of CRUISE warning lamp judged from ASCD status signal received from ECM with CAN communication line.
BA W/L [Off]		This item is displayed, but cannot be monitored.
ATC/T-AMT W/L [On/Off]		Status of A/T check warning lamp judged from A/T check indicator signal received from TCM with CAN communication line.
4WD W/L [On/Off]		This item is displayed, but cannot be monitored.
4WD LOCK IND [Off]		This item is displayed, but cannot be monitored.
FUEL W/L [On/Off]		Low-fuel warning lamp status judged by the identified fuel level.
WASHER W/L [On/Off]		Status of washer warning lamp judged from washer level switch input to combination meter.
AIR PRES W/L [On/Off]		Status of low tire pressure warning lamp judged from tire pressure signal received from BCM with CAN communication line.
KEY G/Y W/L [On/Off]		Status of key warning lamp (G/Y) judged from key warning signal received from BCM with CAN communication line.
AFS OFF IND [On/Off]		Status of AFS OFF indicator lamp judged from AFS OFF indicator lamp signal received from AFS control unit with CAN communication line.
4WAS/RAS W/L [On/Off]		Status of 4WAS warning lamp judged from 4WAS warning lamp signal received from 4WAS main control unit with CAN communication line.
HDC W/L [On/Off]		This item is displayed, but cannot be monitored.
LDP R IND [On/Off]		This item is displayed, but cannot be monitored.
LDP G Y IND [On/Off]		This item is displayed, but cannot be monitored.

DIAGNOSIS SYSTEM (UNIFIED METER AND A/C AMP.)

< FUNCTION DIAGNOSIS >

Display item [Unit]	MAIN SIGNALS	Description	A
LCD [B&P N, B&P I, ID NG, ROTAT, SFT P, INSRT, BATT, NO KY,OUTKY, LK WN, C&P N, C&P I]		Displays status of Intelligent Key system warning judged from meter display signal received from BCM with CAN communication line.	B
ACC TARGET [On/Off]		Status of vehicle ahead detection indicator judged from meter display signal received from ICC sensor integrated unit with CAN communication line.	C
ACC DISTANCE [Off, SHOR, MID, LONG]		Status of set distance indicator judged from meter display signal received from ICC sensor integrated unit with CAN communication line.	D
ACC OWN VHL [On/Off]		Status of own vehicle indicator judged from meter display signal received from ICC sensor integrated unit with CAN communication line.	E
ACC SET SPEED		Display ICC set vehicle speed from meter display signal received from ICC sensor integrated unit with CAN communication line.	F
ACC UNIT [On/Off]		Status of display unit judged from meter display signal received from ICC sensor integrated unit with CAN communication line.	G
O/D OFF SW [On/Off]		This item is displayed, but cannot be monitored.	H
SHIFT IND [P, R, N, D, M1, M2, M3, M4, M5]		Status of shift position indicator judged from shift position signal and manual mode indicator signal received from TCM with CAN communication line.	I
AT S MODE SW [On/Off]		Status of snow mode switch.	J
AT P MODE SW [On/Off]		This item is displayed, but cannot be monitored.	K
M RANGE SW [On/Off]		Status of manual mode switch.	L
NM RANGE SW [On/Off]		Status of not manual mode switch.	M
AT SFT UP SW [On/Off]		Status of A/T shift up switch.	WCS
AT SFT DWN SW [On/Off]		Status of A/T shift down switch.	O
ST SFT UP SW [On/Off]		Status of paddle shifter up switch.	P
ST SFT DWN SW [On/Off]		Status of paddle shifter down switch.	
COMP F/B SIG [On/Off]		A/C compressor activation condition that ECM judges according to the water temperature and the acceleration degree.	
4WD LOCK SW [Off]		This item is displayed, but cannot be monitored.	
PKB SW [On/Off]		Status of parking brake switch.	
BUCKLE SW [On/Off]		Status of seat belt buckle switch.	
BRAKE OIL SW [On/Off]		Status of brake fluid level switch.	
DISTANCE [km]		Value of possible driving distance calculated by unified meter and A/C amp.	
OUTSIDE TEMP [°C or °F]		Ambient air temperature value converted from ambient sensor signal received from ambient sensor. NOTE: This may not match with the temperature value indicated on the information display. (Because the information display value is a corrected value from the ambient sensor input value.)	

DIAGNOSIS SYSTEM (UNIFIED METER AND A/C AMP.)

< FUNCTION DIAGNOSIS >

Display item [Unit]	MAIN SIGNALS	Description
FUEL LOW SIG [On/Off]		Status of fuel level low warning signal to output to AV control unit with CAN communication line.
BUZZER [On/Off]	X	Buzzer status (in the combination meter) is judged with the buzzer output signal received from each unit with CAN communication line and the warning output condition of the combination meter.

NOTE:

Some items are not available according to vehicle specification.

DIAGNOSIS SYSTEM (BCM)

< FUNCTION DIAGNOSIS >

DIAGNOSIS SYSTEM (BCM)

COMMON ITEM

COMMON ITEM : CONSULT-III Function (BCM - COMMON ITEM)

INFOID:000000001683785

APPLICATION ITEM

CONSULT-III performs the following functions via CAN communication with BCM.

Diagnosis mode	Function Description
Work Support	Changes the setting for each system function.
Self Diagnostic Result	Displays the diagnosis results judged by BCM.
CAN DIAG SUPPORT MNTR	Monitors the reception status of CAN communication viewed from BCM. Refer to CONSULT-III operation manual.
Data Monitor	The BCM input/output signals are displayed.
Active Test	The signals used to activate each device are forcibly supplied from BCM.
Ecu Identification	The BCM part number is displayed.
Configuration	This function is not used even though it is displayed.

SYSTEM APPLICATION

BCM can perform the following functions for each system.

NOTE:

It can perform the diagnosis modes except the following for all sub system selection items.

System	Sub system selection item	Diagnosis mode		
		Work Support	Data Monitor	Active Test
Door lock	DOOR LOCK	×	×	×
Rear window defogger	REAR DEFOGGER		×	×
Warning chime	BUZZER		×	×
Interior room lamp timer	INT LAMP	×	×	×
Exterior lamp	HEAD LAMP	×	×	×
Wiper and washer	WIPER	×	×	×
Turn signal and hazard warning lamps	FLASHER	×	×	×
Air conditioner*	AIR CONDITONER		×	
Intelligent Key system	INTELLIGENT KEY	×	×	×
Combination switch	COMB SW		×	
BCM	BCM	×		
IVIS - NATS	IMMU		×	×
Interior room lamp battery saver	BATTERY SAVER	×	×	×
Trunk open	TRUNK		×	
Vehicle security system	THEFT ALM	×	×	×
RAP system	RETAINED PWR		×	
Signal buffer system	SIGNAL BUFFER		×	×
TPMS	TPMS (AIR PRESSURE MONITOR)	×	×	×

*: This item is displayed, but is not used.

FREEZE FRAME DATA (FFD) AND IGN COUNTER

Freeze Frame Data

The BCM records the following condition at the moment a particular DTC is detected.

- Vehicle Speed
- Odd Trip Meter

DIAGNOSIS SYSTEM (BCM)

< FUNCTION DIAGNOSIS >

- Vehicle Condition (BCM detected condition)

CONSULT screen terms	Description
SLEEP>LOCK	While turning BCM status from low power consumption mode to normal mode (Power supply position is "LOCK")
SLEEP>OFF	While turning BCM status from low power consumption mode to normal mode (Power supply position is "OFF".)
LOCK>ACC	While turning power supply position from "LOCK" to "ACC"
ACC>ON	While turning power supply position from "ACC" to "IGN"
RUN>ACC	While turning power supply position from "RUN" to "ACC" (Vehicle is stopping and selector lever is except P position.)
CRANK>RUN	While turning power supply position from "CRANKING" to "RUN" (From cranking up the engine to run it)
RUN>URGENT	While turning power supply position from "RUN" to "ACC" (Emergency stop operation)
ACC>OFF	While turning power supply position from "ACC" to "OFF"
OFF>LOCK	While turning power supply position from "OFF" to "LOCK"
OFF>ACC	While turning power supply position from "OFF" to "ACC"
ON>CRANK	While turning power supply position from "IGN" to "CRANKING"
OFF>SLEEP	While turning BCM status from normal mode (Power supply position is "OFF".) to low power consumption mode
LOCK>SLEEP	While turning BCM status from normal mode (Power supply position is "LOCK".) to low power consumption mode
LOCK	Power supply position is "LOCK" (Ignition switch OFF with steering is locked.)
OFF	Power supply position is "OFF" (Ignition switch OFF with steering is unlocked.)
ACC	Power supply position is "ACC" (Ignition switch ACC)
ON	Power supply position is "IGN" (Ignition switch ON with engine stopped)
ENGINE RUN	Power supply position is "RUN" (Ignition switch ON with engine running)
CRANKING	Power supply position is "CRANKING" (At engine cranking)

IGN Counter

IGN counter indicates the number of times that ignition switch is turned ON after DTC is detected.

- The number is 0 when a malfunction is detected now.
- The number increases like 1 → 2 → 3...38 → 39 after returning to the normal condition whenever ignition switch OFF → ON.
- The number is fixed to 39 until the self-diagnosis results are erased if it is over 39.

BUZZER

BUZZER : CONSULT-III Function (BCM - BUZZER)

INFOID:000000001683786

CONSULT-III APPLICATION ITEMS

Test item	Diagnosis mode	Description
BUZZER	Data Monitor	Displays BCM input data in real time.
	Active Test	Operation of electrical loads can be checked by sending driving signal to them.

DATA MONITOR

Display item [Unit]	Description
VEH SPEED 1 [Km/h]	Value of vehicle speed signal received from ABS actuator and electric unit (control unit) with CAN communication line.
PUSH SW [On/Off]	Status of push button ignition switch judged by BCM.

DIAGNOSIS SYSTEM (BCM)

< FUNCTION DIAGNOSIS >

Display item [Unit]	Description	A
UNLK SEN-DR [On/Off]	Status of unlock sensor judged by BCM.	A
KEY SW-SLOT [On/Off]	Status of key slot judged by BCM.	B
TAIL LAMP SW [On/Off]	Status of each switch judged by BCM using the combination switch readout function.	C
FR FOG SW [On/Off]	Status of front fog lamp switch judged by BCM.	D
DOOR SW-DR [On/Off]	Status of driver side door switch judged by BCM.	D

ACTIVE TEST

Display item [Unit]	Description	E
IGN KEY WARN ALM	The key warning chime operation can be checked by operating the relevant function (On/Off).	F
SEAT BELT WARN TEST	The seat belt warning chime operation can be checked by operating the relevant function (On/Off).	G
ID REGIST WARNING	The ID regist warning chime operation can be checked by operating the relevant function (On/Off).	G
LIGHT WARN ALM	The light warning chime operation can be checked by operating the relevant function (On/Off).	H
RUN FLAT/T WARN BUZZER	The run-flat tire warning chime operation can be checked by operating the relevant function (On/Off).	H

WCS

POWER SUPPLY AND GROUND CIRCUIT

< COMPONENT DIAGNOSIS >

COMPONENT DIAGNOSIS

POWER SUPPLY AND GROUND CIRCUIT COMBINATION METER

COMBINATION METER : Diagnosis Procedure

INFOID:000000001677413

1.CHECK FUSE

Check for blown fuses.

Power source	Fuse No.
Battery	11
Ignition switch ON or START	4

Is the inspection result normal?

YES >> GO TO 2.

NO >> Be sure to eliminate cause of malfunction before installing new fuse.

2.CHECK POWER SUPPLY CIRCUIT

Check voltage between combination meter harness connector terminal and ground.

Terminals		Ignition switch	Voltage (Approx.)
(+)	(-)		
Combination meter	Ground	OFF	Battery voltage
Connector		ON	
M53	1		
	21		

Is the inspection result normal?

YES >> GO TO 3.

NO >> Check harness between combination meter and fuse.

3.CHECK GROUND CIRCUIT

1. Turn ignition switch OFF.
2. Disconnect combination meter connector.
3. Check continuity between combination meter harness connector terminal and ground.

Combination meter		Ground	Continuity
Connector	Terminals		
M53	5	Ground	Existed
	15		
	22		

Is the inspection result normal?

YES >> INSPECTION END

NO >> Repair harness or connector.

UNIFIED METER AND A/C AMP.

UNIFIED METER AND A/C AMP. : Diagnosis Procedure

INFOID:000000001677414

1.CHECK FUSE

Check for blown fuses.

POWER SUPPLY AND GROUND CIRCUIT

< COMPONENT DIAGNOSIS >

Power source	Fuse No.
Battery	6
Ignition switch ACC or ON	19
Ignition switch ON or START	3

Is the inspection result normal?

YES >> GO TO 2.

NO >> Be sure to eliminate cause of malfunction before installing new fuse.

2.CHECK POWER SUPPLY CIRCUIT

Check voltage between unified meter and A/C amp. harness connector terminal and ground.

Terminals		Ignition switch	Voltage (Approx.)
(+)	(-)		
Unified meter and A/C amp.	Ground	OFF	Battery voltage
Connector		ACC	
Terminals		ON	
M67	54		
	41		
	53		

Is the inspection result normal?

YES >> GO TO 3.

NO >> Check harness between unified meter and A/C amp. and fuse.

3.CHECK GROUND CIRCUIT

1. Turn ignition switch OFF.
2. Disconnect unified meter and A/C amp. connector.
3. Check continuity between unified meter and A/C amp. harness connector terminal and ground.

Unified meter and A/C amp.		Ground	Continuity
Connector	Terminals		
M67	55		Existed
	71		

Is the inspection result normal?

YES >> INSPECTION END

NO >> Repair harness or connector.

BCM (BODY CONTROL MODULE)

BCM (BODY CONTROL MODULE) : Diagnosis Procedure

INFOID:000000001677418

1.CHECK FUSE AND FUSIBLE LINK

Check that the following fuse and fusible link are not blown.

Signal name	Fuse and fusible link No.
Battery power supply	K
	10

Is the fuse fusing?

YES >> Replace the blown fuse or fusible link after repairing the affected circuit if a fuse or fusible link is blown.

NO >> GO TO 2.

2.CHECK POWER SUPPLY CIRCUIT

POWER SUPPLY AND GROUND CIRCUIT

< COMPONENT DIAGNOSIS >

1. Turn ignition switch OFF.
2. Disconnect BCM connectors.
3. Check voltage between BCM harness connector and ground.

Terminals		Voltage (Approx.)
(+)	(-)	
BCM		Ground
Connector	Terminal	
M118	1	
M119	11	Battery voltage

Is the measurement value normal?

YES >> GO TO 3.

NO >> Repair harness or connector.

3.CHECK GROUND CIRCUIT

Check continuity between BCM harness connector and ground.

BCM		Ground	Continuity
Connector	Terminal		
M119	13		Existed

Does continuity exist?

YES >> INSPECTION END

NO >> Repair harness or connector.

METER BUZZER CIRCUIT

< COMPONENT DIAGNOSIS >

METER BUZZER CIRCUIT

Description

INFOID:000000001606827

- The buzzer for warning chime system is installed in the combination meter.
- The combination meter sounds the alarm buzzer based on the signals transmitted from various units.

Component Function Check

INFOID:000000001606828

1. CHECK OPERATION OF METER BUZZER

1. Connect the CONSULT-III.
2. Perform "LIGHT WARN ALM" in "ACTIVE TEST" of "BCM (BUZZER)".

Does meter buzzer beep?

- YES >> INSPECTION END
- NO >> GO TO 2.

2. CHECK UNIFIED METER AND A/C AMP. INPUT SIGNAL

Select the "Data Monitor" of "METER/M&A" and check the "BUZZER" monitor value.

"BUZZER"

Under the condition of buzzer input : On

Except above : Off

Is the inspection result normal?

- YES >> Replace combination meter.
- NO >> Replace BCM. Refer to [BCS-79, "Removal and Installation"](#).

Diagnosis Procedure

INFOID:000000001606829

1. CHECK POWER SUPPLY OF COMBINATION METER

Check power supply of combination meter. Refer to [WCS-20, "COMBINATION METER : Diagnosis Procedure"](#).

Is the inspection result normal?

- YES >> GO TO 2.
- NO >> Repair power supply circuit of combination meter.

2. CHECK BATTERY POWER SUPPLY OF UNIFIED METER AND A/C AMP.

Check battery power supply of unified meter and A/C amp. Refer to [WCS-20, "UNIFIED METER AND A/C AMP. : Diagnosis Procedure"](#).

Is the inspection result normal?

- YES >> INSPECTION END
- NO >> Repair power supply circuit of unified meter and A/C amp.

A
B
C
D
E
F
G
H
I
J
K
L
M
O
P

WCS

SEAT BELT BUCKLE SWITCH SIGNAL CIRCUIT

< COMPONENT DIAGNOSIS >

SEAT BELT BUCKLE SWITCH SIGNAL CIRCUIT

Description

INFOID:000000001606830

Transmits a seat belt buckle switch signal to the unified meter and A/C amp.

Component Function Check

INFOID:000000001606831

1.CHECK UNIFIED METER AND A/C AMP. INPUT SIGNAL

1. Connect the CONSULT-III.
2. Select the "Data Monitor" of the "METER/M&A" and check the "BUCKLE SW" monitor value.

"BUCKLE SW"

When seat belt is fastened : Off

When seat belt is unfastened : On

>> INSPECTION END

Diagnosis Procedure

INFOID:000000001606832

1.CHECK UNIFIED METER AND A/C AMP. INPUT SIGNAL

1. Turn ignition switch ON.
2. Check voltage between unified meter and A/C amp. harness connector terminal and ground.

Terminal		(-)	Condition	Voltage (Approx.)
(+)				
Combination meter	Connector			
M66	9	Ground	When seat belt is fastened	12 V
			When seat belt is unfastened	0 V

Is the inspection result normal?

YES >> Replace unified meter and A/C amp.

NO >> GO TO 2.

2.CHECK SEAT BELT BUCKLE SWITCH (DRIVER SIDE) SIGNAL CIRCUIT

1. Turn ignition switch OFF.
2. Disconnect unified meter and A/C amp. connector and seat belt buckle switch (driver side) connector.
3. Check continuity between unified meter and A/C amp. harness connector terminal and seat belt buckle switch (driver side) harness connector terminal.

Unified meter and A/C amp.		seat belt buckle switch (driver side)		Continuity
Connector	Terminal	Connector	Terminal	
M66	9	B13	1	Existed

4. Check harness continuity between unified meter and A/C amp. harness connector terminal and ground.

Unified meter and A/C amp.		Ground	Continuity
Connector	Terminal		
M66	9		Not existed

Is the inspection result normal?

YES >> GO TO 3.

NO >> Repair harness or connector.

3.CHECK SEAT BELT BUCKLE SWITCH (DRIVER SIDE) GROUND CIRCUIT

SEAT BELT BUCKLE SWITCH SIGNAL CIRCUIT

< COMPONENT DIAGNOSIS >

Check harness continuity between seat belt buckle switch (driver side) harness connector terminal and ground.

seat belt buckle switch (driver side)		Ground	Continuity
Connector	Terminal		Existed
B13	2		Existed

Is the inspection result normal?

YES >> INSPECTION END

NO >> Repair harness or connector.

Component Inspection

INFOID:000000001606833

1. CHECK SEAT BELT BUCKLE SWITCH (DRIVER SIDE)

1. Turn ignition switch OFF.
2. Disconnect the seat belt buckle switch (driver side) connector.
3. Check continuity between terminals 1 and 2.

Terminal		Seat belt buckle switch (driver side)	Continuity
1	2	When seat belt is fastened	Not existed
		When seat belt is unfastened	Existed

Is the inspection result normal?

YES >> INSPECTION END

NO >> Replace the seat belt buckle switch (driver side). Refer to [SB-12. "SEAT BELT BUCKLE : Removal and Installation"](#).

A
B
C
D
E
F
G
H
I
J
K
L
M
O
P

WCS

WARNING CHIME SYSTEM

< COMPONENT DIAGNOSIS >

WARNING CHIME SYSTEM

Wiring Diagram — WARNING CHIME —

INFOID:000000001606834

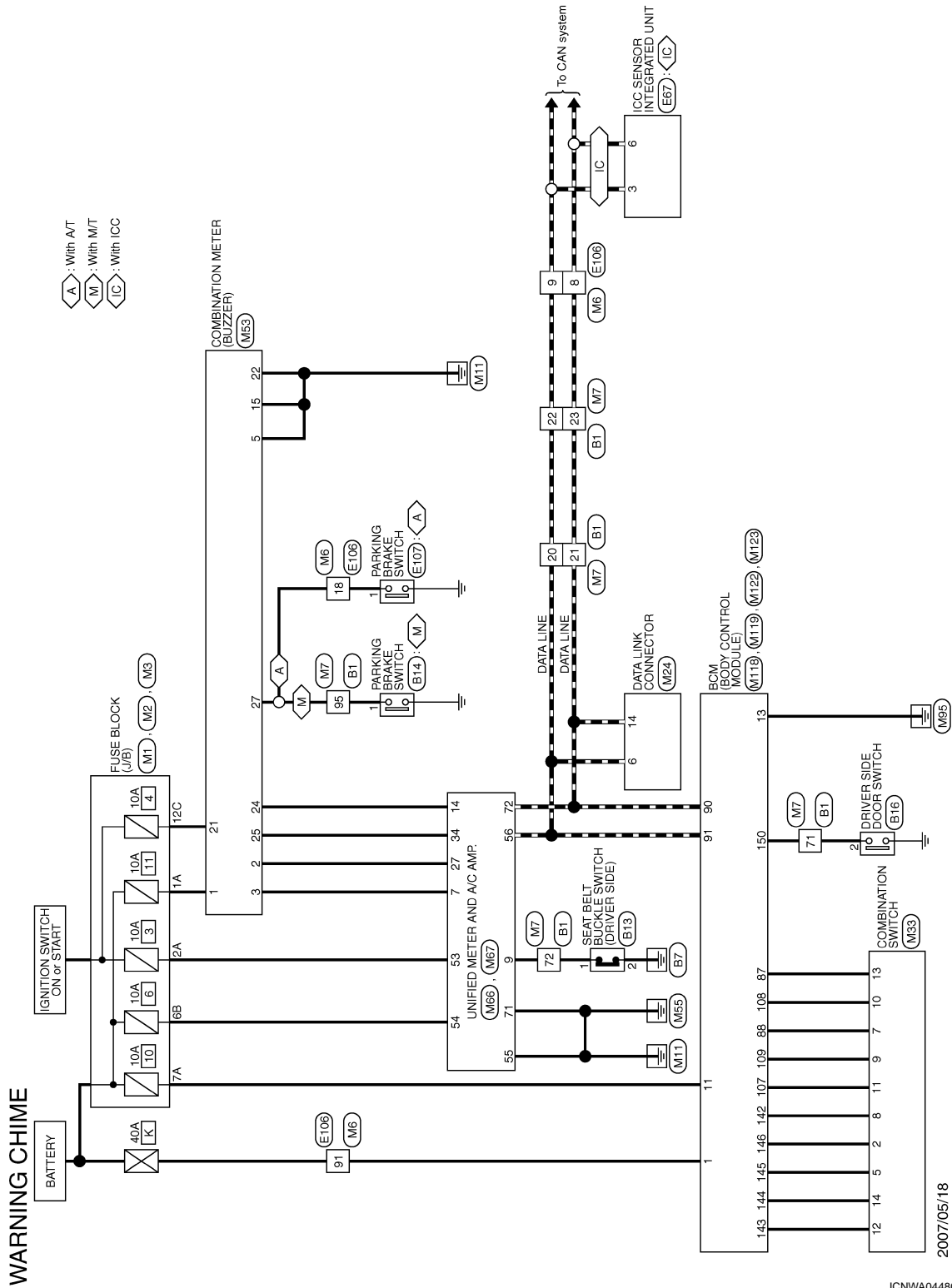

WARNING CHIME SYSTEM

< COMPONENT DIAGNOSIS >

WARNING CHIME

Connector No.	B1
Connector Name	WIRE TO WIRE
Connector Type	TH80FW-CS16-TM4

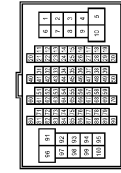

Terminal No.	Color of Wire	Signal Name [Specification]
20	L	-
21	P	-
22	P	-
23	P	-
71	V	-
72	G	-
95	V	-

Connector No.	B13
Connector Name	SEAT BELT BUCKLE SWITCH (DRIVER SIDE)
Connector Type	A03FW

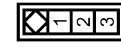

Terminal No.	Color of Wire	Signal Name [Specification]
1	G	-
2	B	-

Connector No.	B14
Connector Name	PARKING BRAKE SWITCH (M/T)
Connector Type	P01FB-A



Terminal No.	Color of Wire	Signal Name [Specification]
1	V	-

Connector No.	B16
Connector Name	DRIVER SIDE DOOR SWITCH
Connector Type	A03FW

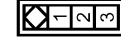

Terminal No.	Color of Wire	Signal Name [Specification]
2	V	-

Connector No.	E67
Connector Name	ICC SENSOR INTEGRATED UNIT
Connector Type	RS09FB-PR



Terminal No.	Color of Wire	Signal Name [Specification]
3	L	CAN-H
6	P	CAN-L

Connector No.	E106
Connector Name	WIRE TO WIRE
Connector Type	TH80FW-CS16-TM4

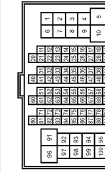

Terminal No.	Color of Wire	Signal Name [Specification]
8	P	-
9	L	-
18	O	-
91	W	-

Connector No.	E107
Connector Name	PARKING BRAKE SWITCH (A/T)
Connector Type	TE01FW



Terminal No.	Color of Wire	Signal Name [Specification]
1	O	-

Connector No.	M1
Connector Name	FUSE BLOCK (J/B)
Connector Type	NS09FW-M2

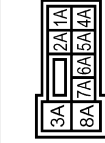

Terminal No.	Color of Wire	Signal Name [Specification]
1A	V	-
2A	G	-
7A	R	-

A
B
C
D
E
F
G
H
I
J
K
L
M
O
P

WCS

JCNWA0449GE

WARNING CHIME SYSTEM

< COMPONENT DIAGNOSIS >

WARNING CHIME

Connector No.	M2
Connector Name	FUSE BLOCK (J/B)
Connector Type	NS10FW-CS



Terminal No.	Color of Wire	Signal Name [Specification]
6B	Y	-

Connector No.	M3
Connector Name	FUSE BLOCK (J/B)
Connector Type	NS12FW-CS

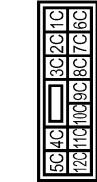

Terminal No.	Color of Wire	Signal Name [Specification]
12C	R	-

Connector No.	M6
Connector Name	WIRE TO WIRE
Connector Type	TH80MM-CS16-TM4



Terminal No.	Color of Wire	Signal Name [Specification]
8	P	-
9	L	-
18	O	-
91	W	-

Connector No.	M7
Connector Name	WIRE TO WIRE
Connector Type	TH80MM-CS16-TM4



Terminal No.	Color of Wire	Signal Name [Specification]
20	L	-
21	P	-
22	L	-
23	P	-
71	R	- [With A/T]
72	L	- [With M/T]
72	LG	- [With M/T]
95	O	-

Connector No.	M24
Connector Name	DATA LINK CONNECTOR
Connector Type	BD16FW

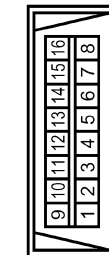

Terminal No.	Color of Wire	Signal Name [Specification]
6	L	-
14	P	-

Connector No.	M33
Connector Name	COMBINATION SWITCH
Connector Type	TH16FW-NH

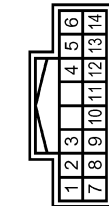

Terminal No.	Color of Wire	Signal Name [Specification]
2	SB	OUTPUT 4
5	L	OUTPUT 3
7	O	INPUT 3
8	BR	OUTPUT 5
9	W	INPUT 2
10	R	INPUT 4
11	LG	INPUT 1
12	V	OUTPUT 1
13	Y	INPUT 5
14	G	OUTPUT 2

Connector No.	M33
Connector Name	COMBINATION METER
Connector Type	SAE6FW

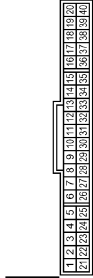

Terminal No.	Color of Wire	Signal Name [Specification]
1	V	BAT
2	LG	COMM (METER->AMP)
3	GR	COMM (AMP->METER)
5	B	GND
15	B	GND
21	R	IGN
22	B	GND
24	BR	COMM (LCD->AMP)
25	Y	COMM (AMP->LCD)
27	O	PARKING BRAKE SW

Connector No.	M66
Connector Name	UNIFIED METER AND A/C AMP.
Connector Type	TH40FW-NH

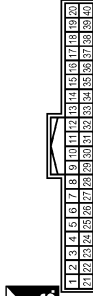

Terminal No.	Color of Wire	Signal Name [Specification]
7	GR	COMM (AMP->METER)
9	SB	SEAT BELT BUCKLE SW (DRIVER SIDE)
14	BR	COMM (LGD->AMP)
27	LG	COMM (METER->AMP)
34	Y	COMM (AMP->LCD)

JCNWA0450GE

WARNING CHIME SYSTEM

< COMPONENT DIAGNOSIS >

WARNING CHIME

Connector No.	M67
Connector Name	UNIFIED METER AND A/C AMP.
Connector Type	TH22TW-NH

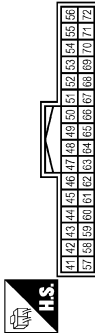

Terminal No.	Color of Wire	Signal Name [Specification]
53	W	IGN
54	Y	BAT
55	B	GND
56	L	CAN-H
71	GR	GND
72	P	CAN-L

Connector No.	M123
Connector Name	BCM (BODY CONTROL MODULE)
Connector Type	TH40FG-NH

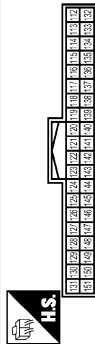

Terminal No.	Color of Wire	Signal Name [Specification]
142	BR	COMBI SW OUTPUT 5
143	V	COMBI SW OUTPUT 1
144	G	COMBI SW OUTPUT 2
145	L	COMBI SW OUTPUT 3
146	SB	COMBI SW OUTPUT 4
150	R	DOOR SW (DR)

Connector No.	M118
Connector Name	BCM (BODY CONTROL MODULE)
Connector Type	MC3FB-LC



Terminal No.	Color of Wire	Signal Name [Specification]
1	W	BAT (F/L)

Connector No.	M119
Connector Name	BCM (BODY CONTROL MODULE)
Connector Type	NS16FW-CS

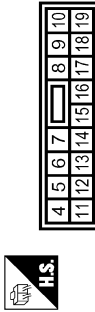

Terminal No.	Color of Wire	Signal Name [Specification]
11	R	BAT (FUSE)
13	B	GND

Connector No.	M122
Connector Name	BCM (BODY CONTROL MODULE)
Connector Type	TH40FB-NH

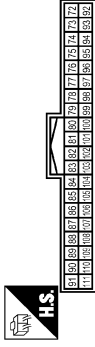

Terminal No.	Color of Wire	Signal Name [Specification]
87	Y	COMBI SW INPUT 5
88	O	COMBI SW INPUT 3
90	P	CAN-L
91	L	CAN-H
107	LG	COMBI SW INPUT 1
108	R	COMBI SW INPUT 4
109	W	COMBI SW INPUT 2

A
B
C
D
E
F
G
H
I
J
K
L
M
N
O
P

WCS

COMBINATION METER

< ECU DIAGNOSIS >

ECU DIAGNOSIS

COMBINATION METER

Reference Value

INFOID:000000001677396

VALUES ON THE DAIAGNOSIS TOOL

Refer to [WCS-44. "Reference Value"](#).

TERMINAL LAYOUT

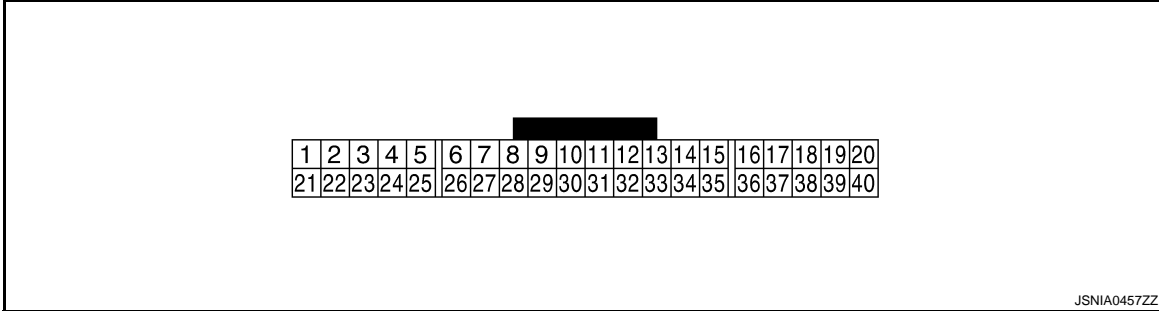

PHYSICAL VALUES

Terminal No. (Wire color)		Description		Condition		Value (Approx.)
+	-	Signal name	Input/ Output			
1 (V)	Ground	Battery power supply	Input	Ignition switch OFF	—	Battery voltage
2 (LG)	Ground	Communication signal (METER→ AMP.)	Output	Ignition switch ON	—	 JSNIA0027GB
3 (GR)	Ground	Communication signal (AMP.→ METER)	Input	Ignition switch ON	—	 JSNIA0027GB
5 (B)	Ground	Ground	—	Ignition switch ON	—	0 V
6 (W)	Ground	Alternator signal	Input	Ignition switch ON	Charge warning lamp ON	0 V
					Charge warning lamp OFF	12 V
7 (LG)	Ground	Air bag signal	Input	Ignition switch ON	Air bag warning lamp ON	4 V
					Air bag warning lamp OFF	0 V
10 (R)	Ground	Security signal	Input	Ignition switch OFF	Security warning lamp ON	0 V
					Security warning lamp OFF	12 V

COMBINATION METER

< ECU DIAGNOSIS >

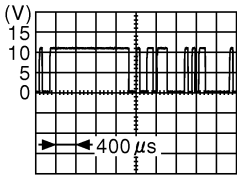
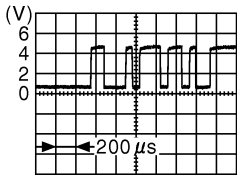
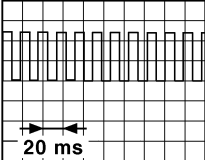
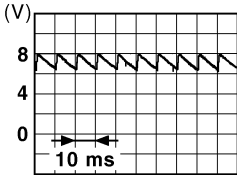
Terminal No. (Wire color)		Description		Condition		Value (Approx.)
+	-	Signal name	Input/ Output			
15 (B)	Ground	Ground	—	Ignition switch ON	—	0 V
16 (B)	Ground	Meter control switch ground	—	Ignition switch ON	—	0 V
21 (R)	Ground	Ignition signal	Input	Ignition switch ON	—	12 V
22 (B)	Ground	Ground	—	Ignition switch ON	—	0 V
24 (BR)	Ground	Communication signal (LCD→ AMP.)	Output	Ignition switch ON	—	 <small>JSNIA0028GB</small>
25 (Y)	Ground	Communication signal (AMP.→ LCD)	Input	Ignition switch ON	—	 <small>JSNIA0027GB</small>
26 (R)	Ground	Vehicle speed signal (8-pulse)	Input	Ignition switch ON	Speedometer operated [When vehicle speed is ap- prox. 40 km/h (25 MPH)]	<p>NOTE: The maximum voltage varies de- pending on the specification (destination unit).</p>  <small>JSNIA0012GB</small>
27 (O)	Ground	Parking brake switch signal	Input	Ignition switch ON	Parking brake applied	0 V
					Parking brake released	 <small>JSNIA0007GB</small>

A
B
C
D
E
F
G
H
I
J
K
L
M
O
P

WCS

COMBINATION METER

< ECU DIAGNOSIS >

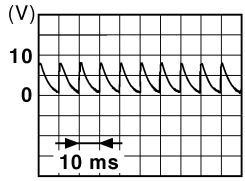
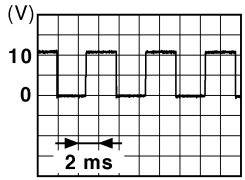
Terminal No. (Wire color)		Description		Condition		Value (Approx.)
+	-	Signal name	Input/ Output			
28 (LG)	Ground	Brake fluid level switch signal	Input	Ignition switch ON	Brake fluid level is normal.	 <small>JSNIA0008GB</small>
					The brake fluid level is lower than the low level	0 V
29 (L* ¹ or LG* ²)	Ground	Seat belt buckle switch signal (driver side)	Input	Ignition switch ON	When driver seat belt is fastened	12 V
					When driver seat belt is unfastened	0 V
30 (G)	Ground	Seat belt buckle switch signal (passenger side)	Input	Ignition switch ON	<ul style="list-style-type: none"> When getting in the passenger seat When passenger seat belt is fastened 	12 V
					<ul style="list-style-type: none"> When getting in the passenger seat When passenger seat belt is unfastened 	0 V
31 (L)	Ground	Washer level switch signal	Input	Ignition switch ON	Washer level switch ON	0 V
					Washer level switch OFF	5 V
34 (R)	Ground	Illumination control signal	Output	Ignition switch ON	Lighting switch ON, then operate the illumination control switch.	<p>NOTE: When brightness level is midway</p>  <small>JSNIA0010GB</small>
36 (LG)	16 (B)	Select switch signal	Input	Ignition switch ON	When ● is pressed	0 V
					Other than the above	5 V
37 (SB)	16 (B)	Enter switch signal	Input	Ignition switch ON	When □ is pressed	0 V
					Other than the above	5 V
38 (L)	16 (B)	Trip A/B reset switch signal	Input	Ignition switch ON	When trip A/B reset switch is pressed	0 V
					Other than the above	5 V
39 (P)	16 (B)	Illumination control switch signal (-)	Input	Ignition switch ON	When ⏻ switch is pressed	0 V
					Other than the above	5 V
40 (O)	16 (B)	Illumination control switch signal (+)	Input	Ignition switch ON	When ⏩ switch is pressed	0 V
					Other than the above	5 V

*1: With A/T models

*2: With M/T models

COMBINATION METER

< ECU DIAGNOSIS >

Wiring Diagram - METER -

INFOID:000000001677397

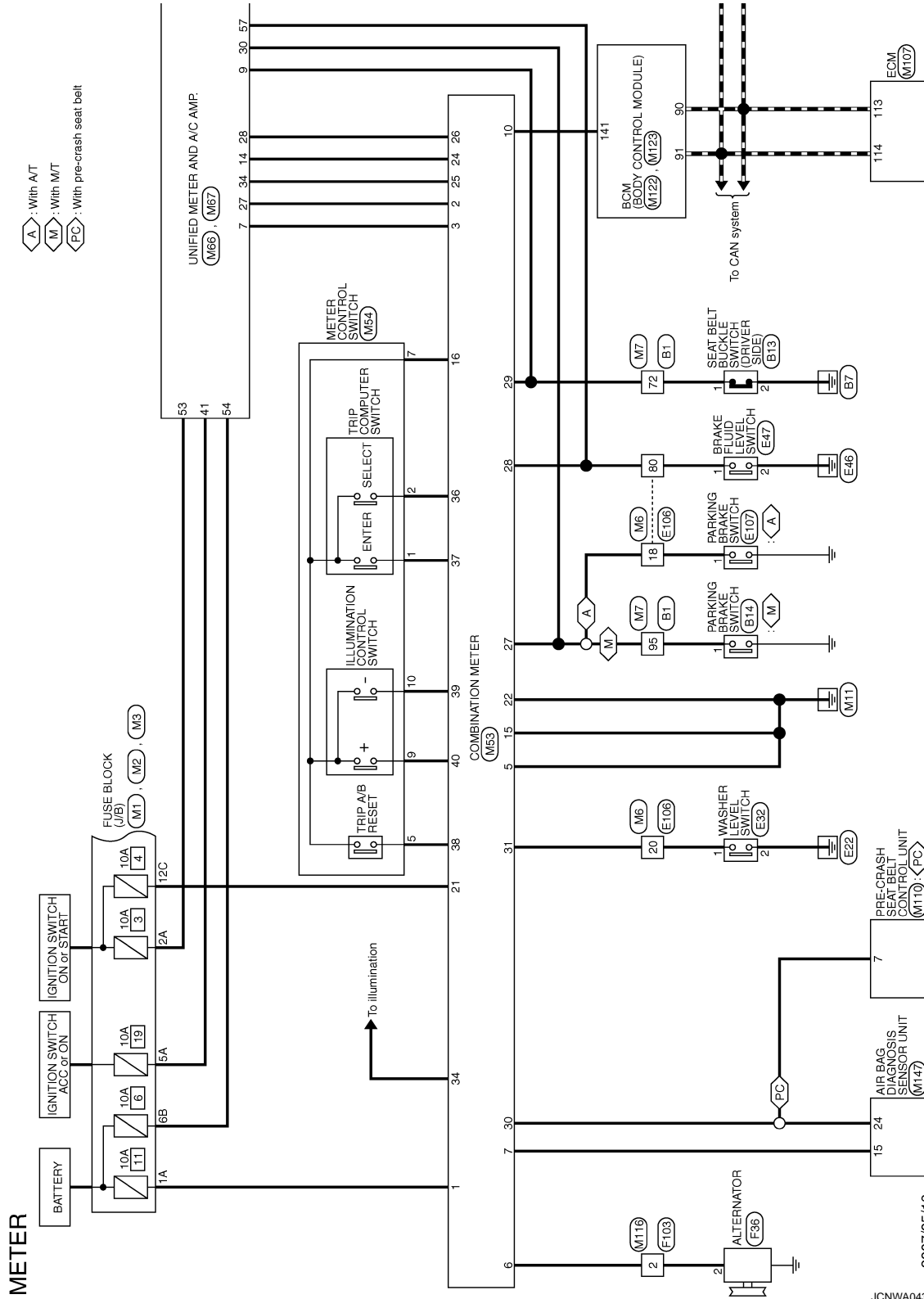

2007/05/18

JCNWA0436GE

A
B
C
D
E
F
G
H
I
J
K
L
M
N
O
P

WCS

COMBINATION METER

< ECU DIAGNOSIS >

- : With AT
- : With AFS
- : With NAVI
- : Without NAVI
- : With ICC
- : With 4WAS
- : With paddle shifter switch

*: This connector is not shown in "Harness Layout".

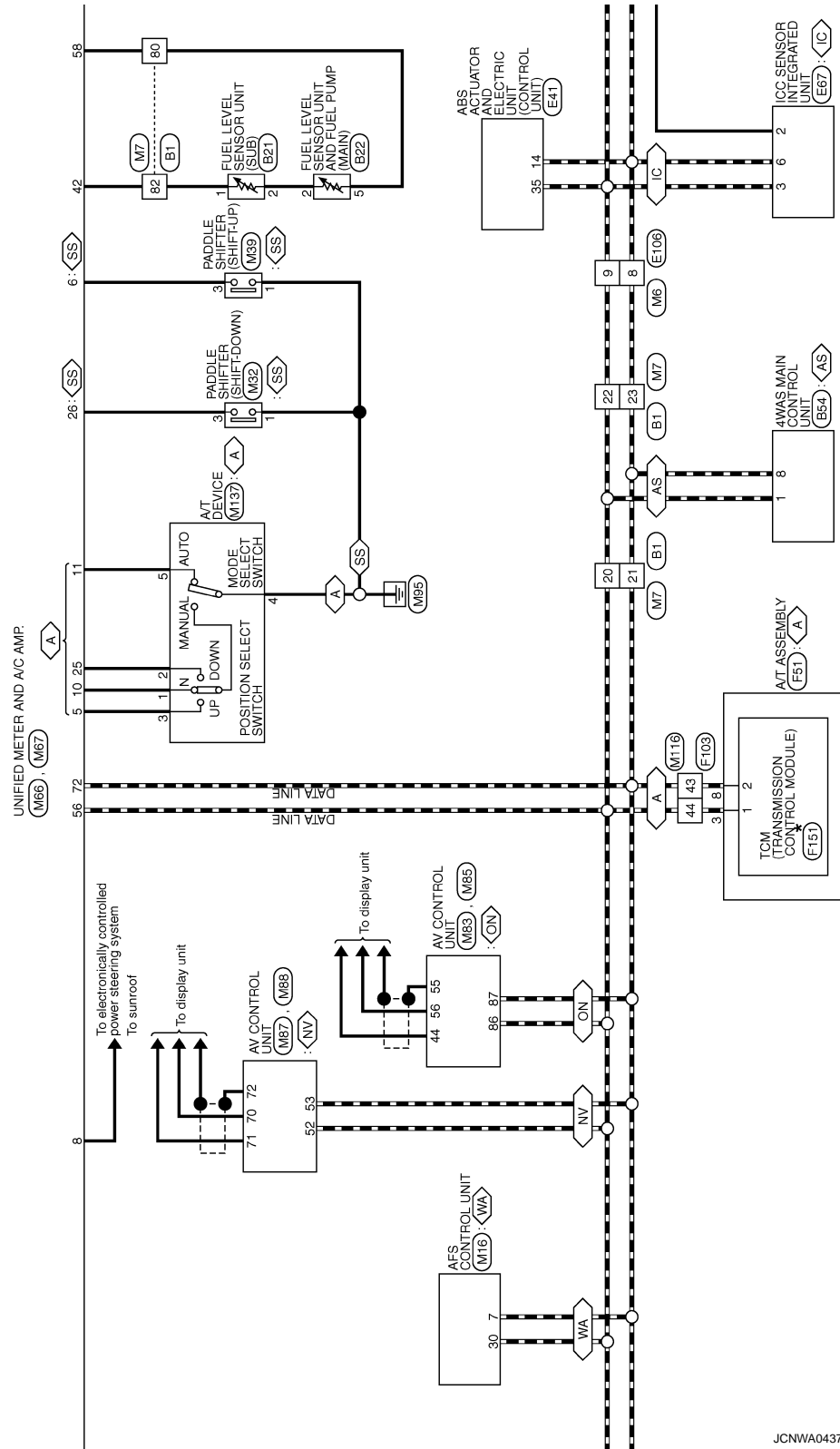

JCNWA0437GE

COMBINATION METER

< ECU DIAGNOSIS >

⬠ : With ICC

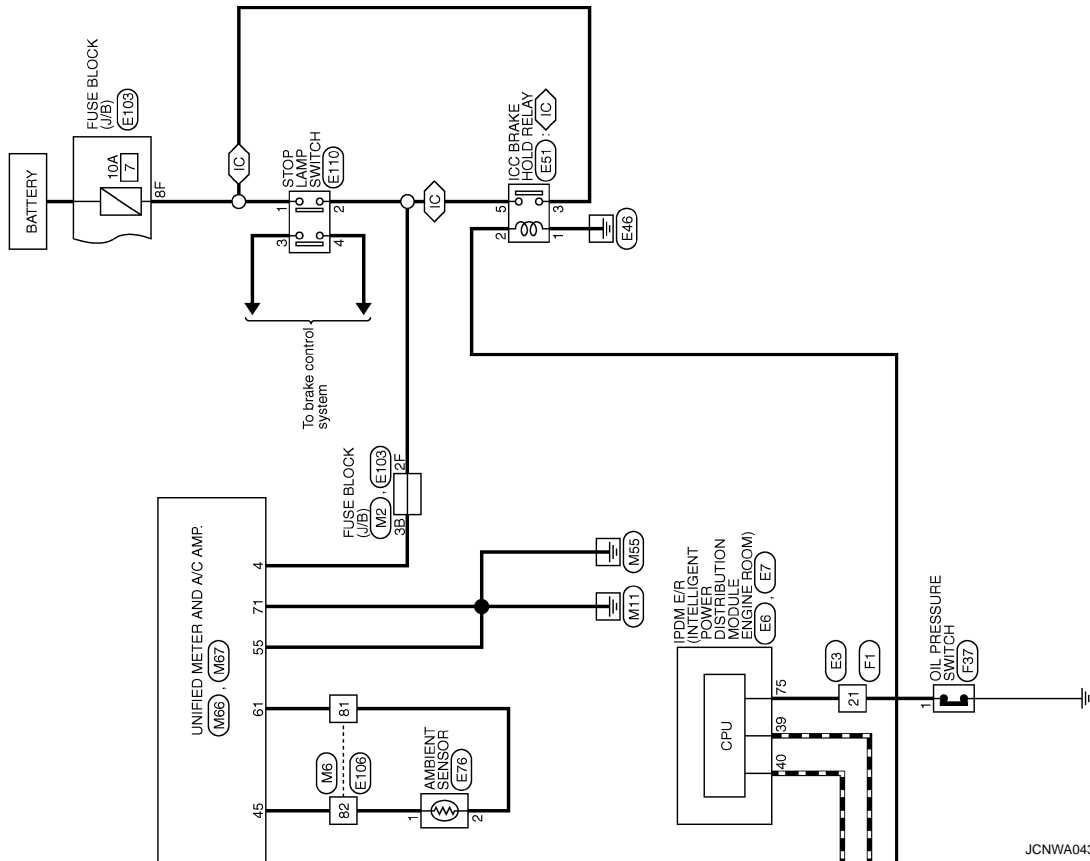

JCNWA0438GE

A
B
C
D
E
F
G
H
I
J
K
L
M
N
O
P

WCS

COMBINATION METER

< ECU DIAGNOSIS >

METER

Connector No.	B1	Connector No.	B13	Connector No.	B14	Connector No.	B21	Connector No.	E3	Connector No.	E6	Connector No.	E8
Connector Name	WIRE TO WIRE	SEAT BELT BUCKLE SWITCH (DRIVER SIDE)	PARKING BRAKE SWITCH (M/T)	FUEL LEVEL SENSOR UNIT (SUB)	FUEL LEVEL SENSOR UNIT (SUB)	SEAT BELT BUCKLE SWITCH (DRIVER SIDE)	FUEL LEVEL SENSOR UNIT (SUB)	WIRE TO WIRE	SPASMB-RSP-SHZ3	WIRE TO WIRE	WIRE TO WIRE	WIRE TO WIRE	INTELLIGENT POWER DISTRIBUTION MODULE (ENGINE ROOM)
Connector Type	THBDFW-GS16-TM4	A3BFW	PO1FB-A	ED2FGY-RS	ED2FGY-RS	A3BFW	ED2FGY-RS	SPASMB-RSP-SHZ3	SPASMB-RSP-SHZ3	THBDFW-M4	THBDFW-M4	THBDFW-M4	THBDFW-MH
Terminal No.	20	21	22	23	80	82	95	1	2	1	2	39	40
Color of Wire	L	P	L	P	Y	B	V	V	W	V	B	P	L
Signal Name [Specification]													

COMBINATION METER

< ECU DIAGNOSIS >

METER

Connector No. E7	IPDM E/R (INTELLIGENT POWER DISTRIBUTION MODULE ENGINE ROOM)	TH20TW-GS12-1M4		Terminal No. 75	SB	Signal Name [Specification]	
Connector No. E41	ABS ACTUATOR AND ELECTRIC UNIT (CONTROL UNIT)	BA042EB-AH24-LH1		Terminal No. 14	P	CAN-L	
Connector No. E47	BRAKE FLUID LEVEL SWITCH	Y102FGY		Terminal No. 1	W		Signal Name [Specification]
Connector No. E51	ICC BRAKE HOLD RELAY	MS22FL-M2		Terminal No. 1	B		
Connector No. E52	WASHER LEVEL SWITCH	Z02EBR		Terminal No. 1	LG		
Connector No. E56	AMBIENT SENSOR	RS22FB		Terminal No. 2	P		
Connector No. E61	ICC SENSOR INTEGRATED UNIT	RS06FB-PR		Terminal No. 2	V		
Connector No. E67	BRK LMP RLY	CAN-H		Terminal No. 3	L		
Connector No. E76	AMBIENT SENSOR	RS22FB		Terminal No. 2	P		
Connector No. E83	FUSE BLOCK (J/B)	NS16FW-CS		Terminal No. 2F	W		
Connector No. E87	BRK LMP RLY	CAN-L		Terminal No. 6	P		
Connector No. E93	FUSE BLOCK (J/B)	NS16FW-CS		Terminal No. 8F	L		

JCNWA0440GE

A
B
C
D
E
F
G
H
I
J
K
L
M
N
O
P

WCS

COMBINATION METER

< ECU DIAGNOSIS >

METER

Connector No.	F1
Connector Name	WIRE TO WIRE
Connector Type	SA436FB-RS8-SH28

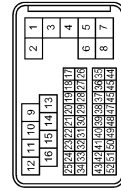

Terminal No.	Color of Wire	Signal Name [Specification]
21	BR	-

Connector No.	E110
Connector Name	STOP LAMP SWITCH
Connector Type	MG4FW-LC

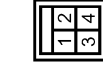

Terminal No.	Color of Wire	Signal Name [Specification]
1	L	-
2	W	-
3	L	-
4	SB	-

Connector No.	E107
Connector Name	PARKING BRAKE SWITCH (A/T)
Connector Type	TE01FW



Terminal No.	Color of Wire	Signal Name [Specification]
1	O	-

Connector No.	E106
Connector Name	WIRE TO WIRE
Connector Type	TH80FW-GS16-TM4

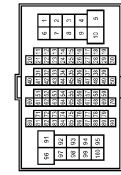

Terminal No.	Color of Wire	Signal Name [Specification]
8	P	-
9	L	-
18	O	-
20	LG	-
80	W	-
81	P	-
82	G	-

Connector No.	F103
Connector Name	WIRE TO WIRE
Connector Type	TK38FW-NS10

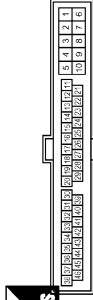

Terminal No.	Color of Wire	Signal Name [Specification]
2	G	-
43	P	-
44	L	-

Connector No.	F51
Connector Name	A/T ASSEMBLY
Connector Type	PK10FG-DGY

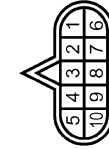

Terminal No.	Color of Wire	Signal Name [Specification]
3	L	-
8	P	-

Connector No.	F37
Connector Name	OIL PRESSURE SWITCH
Connector Type	ED1FGY-RS-AR



Terminal No.	Color of Wire	Signal Name [Specification]
1	BR	-

Connector No.	F38
Connector Name	ALTERNATOR
Connector Type	HS03FB



Terminal No.	Color of Wire	Signal Name [Specification]
2	G	L

JCNWA0441GE

COMBINATION METER

< ECU DIAGNOSIS >

METER

Connector No.	F1B1
Connector Name	TOM (TRANSMISSION CONTROL MODULE)
Connector Type	SP10FBGY

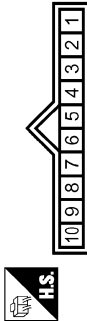

Terminal No.	Color of Wire	Signal Name [Specification]
1	BR	CAN-H
2	L/Y	CAN-L

Connector No.	M1
Connector Name	FUSE BLOCK (J/B)
Connector Type	NS06FW-M2



Terminal No.	Color of Wire	Signal Name [Specification]
1A	V	-
2A	G	-
5A	L	-

Connector No.	M2
Connector Name	FUSE BLOCK (J/B)
Connector Type	NS10FW-CS



Terminal No.	Color of Wire	Signal Name [Specification]
3B	P	-
6B	Y	-

Connector No.	M3
Connector Name	FUSE BLOCK (J/B)
Connector Type	NS17FW-CS

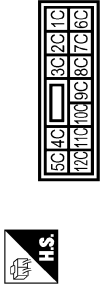

Terminal No.	Color of Wire	Signal Name [Specification]
12C	R	-

Connector No.	M8
Connector Name	WIRE TO WIRE
Connector Type	TH80MW-CS16-TM4

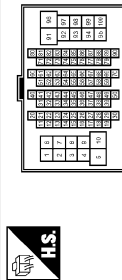

Terminal No.	Color of Wire	Signal Name [Specification]
8	P	-
9	L	-
18	O	-
20	L	-
80	LG	-
81	R	-
82	V	-

Connector No.	M7
Connector Name	WIRE TO WIRE
Connector Type	TH80MW-CS16-TM4

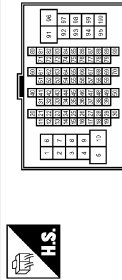

Terminal No.	Color of Wire	Signal Name [Specification]
20	L	-
21	P	-
22	L	-
23	P	-
72	LG	- [With A/T]
80	V	- [With M/T]
82	BR	-
95	O	-

Connector No.	M16
Connector Name	AFS CONTROL UNIT
Connector Type	TH40FW-NH

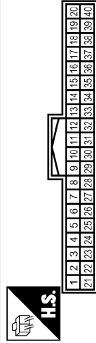

Terminal No.	Color of Wire	Signal Name [Specification]
7	P	CAN-L
30	L	CAN-H

Connector No.	M32
Connector Name	PADDLE SHIFTER (SHIFT-DOWN)
Connector Type	AG3FW



Terminal No.	Color of Wire	Signal Name [Specification]
1	W	-
3	G	-

A
B
C
D
E
F
G
H
I
J
K
L
M
WCS
O
P

COMBINATION METER

< ECU DIAGNOSIS >

METER

Connector No.	M39
Connector Name	PADDLE SHIFTER (SHIFT-UP)
Connector Type	TH4FW



Terminal No.	Color of Wire	Signal Name [Specification]
1	P	-
3	O	-

Connector No.	M53
Connector Name	COMBINATION METER
Connector Type	SAB40FW

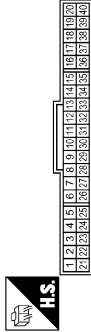

Terminal No.	Color of Wire	Signal Name [Specification]
1	V	BAT
2	LG	COMM (METER->AMP)
3	GR	COMM (AMP->METER)
5	B	GND
6	W	ALTERNATOR
7	LG	AIR BAG
10	R	SECURITY
15	B	GND
16	B	METER CONTROL SW GND
21	R	IGN
22	B	GND

Connector No.	M66
Connector Name	UNIFIED METER AND A/C AMP.
Connector Type	TH40FW-NH

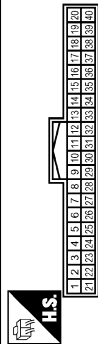

Terminal No.	Color of Wire	Signal Name [Specification]
4	P	STOP LAMP SW
5	L	SHIFT UP SW
6	O	PADDLE UP
7	GR	COMM (AMP->METER)
8	L	VEHICLE SPEED (2-PULSE)
9	SB	SEAT BELT BUCKLE SW (DRIVER SIDE)
10	W	MANUAL MODE SW
11	G	AUTO MODE SW
14	BR	COMM (LCD->AMP)
25	V	SHIFT DOWN SW
26	G	PADDLE DOWN

24	BR	COMM (LCD->AMP)
25	Y	COMM (AMP->LCD)
26	R	VEHICLE SPEED (3-PULSE)
27	O	PARKING BRAKE SW
28	LG	BRAKE FLUID LEVEL SW
29	L	SEAT BELT BUCKLE SW (DRIVER SIDE) [With A/T]
29	LG	SEAT BELT BUCKLE SW (DRIVER SIDE) [With M/T]
30	G	SEAT BELT
31	L	WASHER LEVEL SW
34	R	ILLUMINATION CONTROL
36	LG	SELECT SW
37	SB	ENTER SW
38	L	TRIP A/B RESET SW
39	P	ILLUMINATION CONTROL SW (-)
40	O	ILLUMINATION CONTROL SW (+)

Terminal No.	Color of Wire	Signal Name [Specification]
1	SB	-
2	LG	-
5	L	-
7	B	-
9	O	-
10	P	-

Connector No.	M67
Connector Name	UNIFIED METER AND A/C AMP.
Connector Type	TH432FW-NH

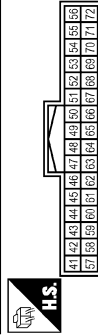

Terminal No.	Color of Wire	Signal Name [Specification]
41	L	ACC
42	BR	FUEL LEVEL SENS
45	V	AMB SENS
53	W	IGN
54	Y	BAT
55	B	GND
56	L	CAN-H
57	BR	BRAKE FLUID LEVEL SW
58	Y	FUEL LEVEL SENS GND
61	R	AMB SENS GND
71	GR	GND

72	P	CAN-L
----	---	-------

COMBINATION METER

< ECU DIAGNOSIS >

METER

Connector No.	M83
Connector Name	AV CONTROL UNIT (WITHOUT NAVI)
Connector Type	TH24FW-NH

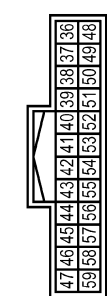

Terminal No.	Color of Wire	Signal Name [Specification]
44	G	COMM (DISP->CONT)
55	SHIELD	SHIELD
56	L	COMM (CONT->DISP)

Connector No.	M85
Connector Name	AV CONTROL UNIT (WITHOUT NAVI)
Connector Type	TH32FW-NH

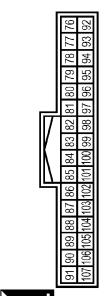

Terminal No.	Color of Wire	Signal Name [Specification]
86	L	CAN-H
87	P	CAN-L

Connector No.	M87
Connector Name	AV CONTROL UNIT (WITH NAVI)
Connector Type	TH40FW-NH

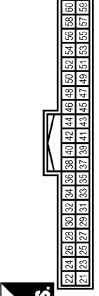

Terminal No.	Color of Wire	Signal Name [Specification]
52	L	CAN-H
53	P	CAN-L

Connector No.	M88
Connector Name	AV CONTROL UNIT (WITH NAVI)
Connector Type	TH12FW-NH

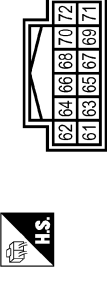

Terminal No.	Color of Wire	Signal Name [Specification]
70	BR	COMM (CONT->DISP)
71	Y	COMM (DISP->CONT)
72	SHIELD	SHIELD

Connector No.	M107
Connector Name	ECM
Connector Type	RH24FGV-R28-R-LH-Z

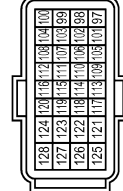

Terminal No.	Color of Wire	Signal Name [Specification]
113	P	VEHCAN-L1
114	L	VEHCAN-H1

Connector No.	M10
Connector Name	PRE-CRASH SEAT BELT CONTROL UNIT
Connector Type	TH20FW-TB6

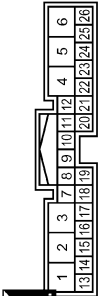

Terminal No.	Color of Wire	Signal Name [Specification]
7	G	INDICATOR

Connector No.	M116
Connector Name	WIRE TO WIRE
Connector Type	TK38MW-NS10

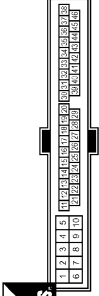

Terminal No.	Color of Wire	Signal Name [Specification]
2	W	-
43	P	-
44	L	-

Connector No.	M122
Connector Name	BCM (BODY CONTROL MODULE)
Connector Type	TH40FB-NH

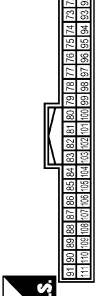

Terminal No.	Color of Wire	Signal Name [Specification]
90	P	CAN-L
91	L	CAN-H

A
B
C
D
E
F
G
H
I
J
K
L
M
O
P

WCS

JCNWA0444GE

COMBINATION METER

< ECU DIAGNOSIS >

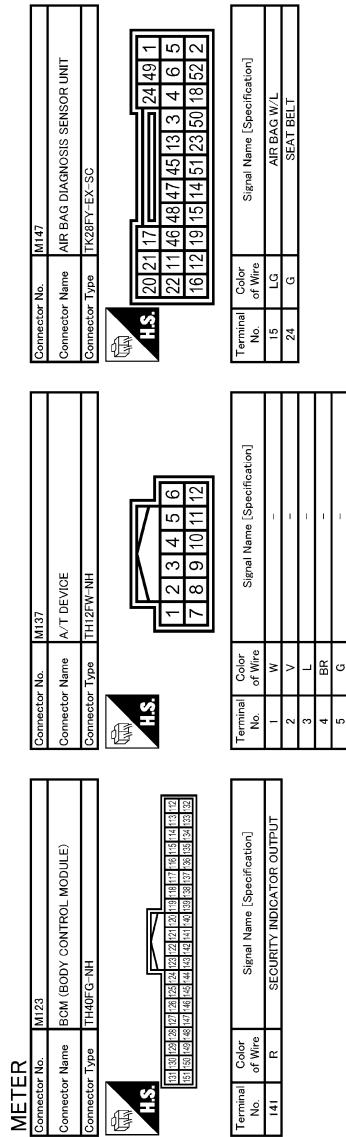

JCNWA0445GE

Fail Safe

INFOID:000000001677398

FAIL SAFE

Combination meter performs fail-safe operation when unified meter and A/C amp. communication is malfunction.

Solution for communication error between the unified meter and A/C amp. and combination meter.

COMBINATION METER

< ECU DIAGNOSIS >

Function		Specifications	
Speedometer		Reset to zero by suspending communication.	A
Tachometer			B
Fuel gauge			C
Water temperature gauge			D
Illumination control		When suspending communication, change to nighttime mode.	E
Information display		The display turns off by suspending communication.	F
Buzzer		The buzzer turns off by suspending communication.	G
Warning lamp/indicator lamp	ABS warning lamp	The lamp turns on by suspending communication.	H
	VDC OFF indicator lamp		I
	SLIP indicator lamp		J
	Brake warning lamp		K
	CRUISE warning lamp		L
	High beam indicator	The lamp turns off by suspending communication.	M
	Turn signal indicator lamp		N
	Front fog indicator lamp		O
	Oil pressure warning lamp		P
	Malfunction indicator lamp		Q
	A/T CHECK warning lamp		R
	Low tire pressure warning lamp		S
	Key warning lamp		T
	AFS OFF indicator lamp		U
4WAS warning lamp	V		
Master warning lamp	W		

DTC Index

INFOID:000000001677399

Refer to [WCS-61, "DTC Index"](#).

WCS

UNIFIED METER AND A/C AMP.

< ECU DIAGNOSIS >

UNIFIED METER AND A/C AMP.

Reference Value

INFOID:000000001677400

VALUES ON THE DIAGNOSIS TOOL

CONSULT-III MONITOR ITEM

Monitor Item	Condition		Value/Status
SPEED METER [km/h]	Ignition switch ON	While driving	Equivalent to speedometer reading NOTE: 655.35 is displayed when the malfunction signal is received
SPEED OUTPUT [km/h]	Ignition switch ON	While driving	Equivalent to speedometer reading NOTE: 655.35 is displayed when the malfunction signal is received
ODO OUTPUT [km]	Ignition switch ON	—	Equivalent to odometer reading in combination meter
TACHO METER [rpm]	Ignition switch ON	While driving	Equivalent to tachometer reading NOTE: 8191.875 is displayed when the malfunction signal is received
FUEL METER [L]	Ignition switch ON	—	Values according to fuel level
W TEMP METER [°C]	Ignition switch ON	—	Values according to engine coolant temperature NOTE: 215 is displayed when the malfunction signal is input
ABS W/L	Ignition switch ON	ABS warning lamp ON	On
		ABS warning lamp OFF	Off
VDC/TCS IND	Ignition switch ON	VDC OFF indicator lamp ON	On
		VDC OFF indicator lamp OFF	Off
SLIP IND	Ignition switch ON	SLIP indicator lamp ON	On
		SLIP indicator lamp OFF	Off
BRAKE W/L	Ignition switch ON	Brake warning lamp ON	On
		Brake warning lamp OFF	Off
DOOR W/L	Ignition switch ON	Door warning displayed	On
		Door warning not displayed	Off
TRUNK/GLAS-H	Ignition switch ON	Trunk warning displayed	On
		Trunk warning not displayed	Off
HI-BEAM IND	Ignition switch ON	Hi-beam indicator lamp ON	On
		Hi-beam indicator lamp OFF	Off
TURN IND	Ignition switch ON	Turn indicator lamp ON	On
		Turn indicator lamp OFF	Off
FR FOG IND	Ignition switch ON	NOTE: This item is displayed, but cannot be monitored.	Off
RR FOG IND	Ignition switch ON	NOTE: This item is displayed, but cannot be monitored.	Off
LIGHT IND	Ignition switch ON	NOTE: This item is displayed, but cannot be monitored.	Off

UNIFIED METER AND A/C AMP.

< ECU DIAGNOSIS >

Monitor Item	Condition		Value/Status	
OIL W/L	Ignition switch ON	Oil pressure warning lamp ON	On	A
		Oil pressure warning lamp OFF	Off	
MIL	Ignition switch ON	Malfunction warning lamp ON	On	B
		Malfunction warning lamp OFF	Off	
GLOW IND	Ignition switch ON	NOTE: This item is displayed, but cannot be monitored.	Off	C
C-ENG2 W/L	Ignition switch ON	NOTE: This item is displayed, but cannot be monitored.	Off	D
CRUISE IND	Ignition switch ON	Cruise indicator displayed	On	
		Cruise indicator not displayed	Off	E
SET IND	Ignition switch ON	Set indicator lamp ON	On	
		Set indicator lamp OFF	Off	
CRUISE W/L	Ignition switch ON	Cruise warning lamp ON	On	F
		Cruise warning lamp OFF	Off	
BA W/L	Ignition switch ON	NOTE: This item is displayed, but cannot be monitored.	Off	G
ATC/T-AMT W/L	Ignition switch ON	A/T check warning lamp ON	On	
		A/T check warning lamp OFF	Off	H
4WD W/L	Ignition switch ON	NOTE: This item is displayed, but cannot be monitored.	Off	I
4WD LOCK IND	Ignition switch ON	NOTE: This item is displayed, but cannot be monitored.	Off	J
FUEL W/L	Ignition switch ON	Low-fuel warning lamp displayed	On	
		Low-fuel warning lamp not displayed	Off	K
WASHER W/L	Ignition switch ON	Washer warning displayed	On	
		Washer warning not displayed	Off	
AIR PRES W/L	Ignition switch ON	Low tire pressure lamp ON	On	L
		Low tire pressure lamp OFF	Off	
KEY G/Y W/L	Ignition switch ON	Key warning lamp ON	On	
		Key warning lamp OFF	Off	M
AFS OFF IND	Ignition switch ON	AFS OFF indicator lamp ON	On	
		AFS OFF indicator lamp OFF	Off	WCS
4WAS/RAS W/L	Ignition switch ON	4WAS warning lamp ON	On	
		4WAS warning lamp OFF	Off	
HDC W/L	Ignition switch ON	NOTE: This item is displayed, but cannot be monitored.	Off	O
LDP R IND	Ignition switch ON	NOTE: This item is displayed, but cannot be monitored.	Off	P
LDP G Y IND	Ignition switch ON	NOTE: This item is displayed, but cannot be monitored.	Off	

UNIFIED METER AND A/C AMP.

< ECU DIAGNOSIS >

Monitor Item	Condition		Value/Status
LCD	Ignition switch ON	Engine start information display (A/T model)	B&P I
		Engine start information display (M/T model)	C&P I
	Ignition switch ACC	Engine start information display (A/T model)	B&P N
		Engine start information display (M/T model)	C&P N
	Ignition switch LOCK	Key ID warning display	ID NG
	Ignition switch LOCK	Steering lock information display	ROTAT
	Ignition switch LOCK	P position warning display	SFT P
	Ignition switch LOCK	Intelligent Key insert information display	INSRT
	Ignition switch LOCK	Intelligent Key low battery warning display	BATT
	Ignition switch ON	Take away warning display	NO KY
	Ignition switch LOCK	Key warning display	OUTKY
Ignition switch ON	ICC sensor integrated unit warning display	LK WN	
ACC TARGET	Ignition switch ON	Vehicle ahead detection indicator displayed	On
		Vehicle ahead detection indicator not displayed	Off
ACC DISTANCE	Ignition switch ON	When following distance set to "LONG"	LONG
		When following distance set to "MIDDLE"	MID
		When following distance set to "SHORT"	SHORT
		Set distance indicator not displayed	Off
ACC OWN VHL	Ignition switch ON	Own vehicle indicator displayed	On
		Own vehicle indicator not displayed	Off
ACC SET SPEED	Ignition switch ON	ICC set vehicle speed display	Vehicle speed
ACC UNIT	Ignition switch ON	Set vehicle speed indicator unit display ON	On
		Set vehicle speed indicator unit display OFF	Off
O/D OFF SW	Ignition switch ON	NOTE: This item is displayed, but cannot be monitored.	Off
SHIFT IND	Ignition switch ON	Shift position indicator P display	P
		Shift position indicator R display	R
		Shift position indicator N display	N
		Shift position indicator D display	D
		Shift position indicator M1 display	M1
		Shift position indicator M2 display	M2
		Shift position indicator M3 display	M3
		Shift position indicator M4 display	M4
AT S MODE SW	Ignition switch ON	Snow mode switch ON	On
		Snow mode switch OFF	Off

UNIFIED METER AND A/C AMP.

< ECU DIAGNOSIS >

Monitor Item	Condition		Value/Status
AT P MODE SW	Ignition switch ON	NOTE: This item is displayed, but cannot be monitored.	Off
M RANGE SW	Ignition switch ON	Selector lever DS position	On
		Other than the above	Off
NM RANGE SW	Ignition switch ON	Selector lever DS position	Off
		Other than the above	On
AT SFT UP SW	Ignition switch ON	Selector lever up position	On
		Other than the above	Off
AT SFT DWN SW	Ignition switch ON	Selector lever – position	On
		Other than the above	Off
ST SFT UP SW	Ignition switch ON	Paddle shifter up operation	On
		Other than the above	Off
ST SFT DWN SW	Ignition switch ON	Paddle shifter down operation	On
		Other than the above	Off
COMP F/B SIG	Ignition switch ON	A/C compressor activation condition	On
		A/C compressor deactivation condition	Off
4WD LOCK SW	Ignition switch ON	NOTE: This item is displayed, but cannot be monitored.	Off
PKB SW	Ignition switch ON	Parking brake applied	On
		Parking brake released	Off
BUCKLE SW	Ignition switch ON	Seat belt (driver side) unfastened	On
		Seat belt (driver side) fastened	Off
BRAKE OIL SW	Ignition switch ON	Brake fluid level is lower than the low level	On
		Brake fluid level is normal	Off
DISTANCE [km]	Ignition switch ON	—	Possible driving distance calculated by unified meter and A/C amp.
OUTSIDE TEMP [°C] or [°F]	Ignition switch ON	—	Equivalent to ambient temperature NOTE: This may not match the indicated value on the information display.
FUEL LOW SIG	Ignition switch ON	Low-fuel warning signal output	On
		Low-fuel warning signal not output	Off
BUZZER	Ignition switch ON	Buzzer ON	On
		Buzzer OFF	Off

NOTE:

Some items are not available according to vehicle specification.

TERMINAL LAYOUT

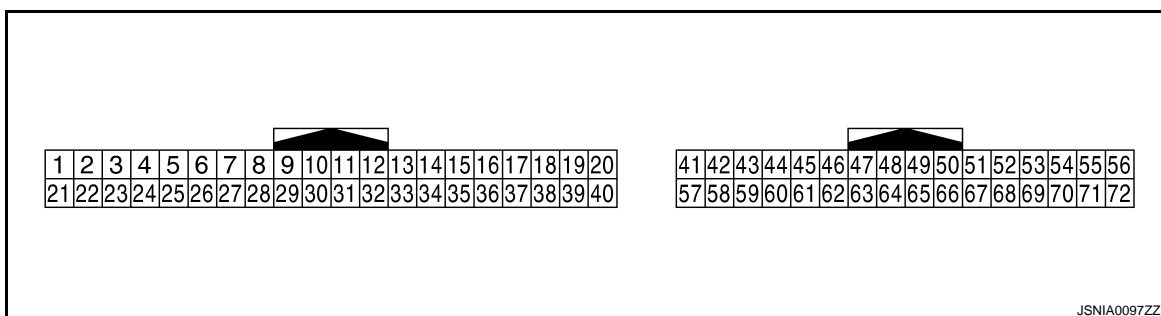

UNIFIED METER AND A/C AMP.

< ECU DIAGNOSIS >

PHYSICAL VALUES

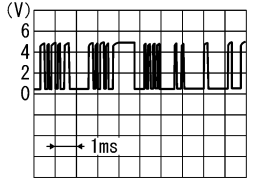
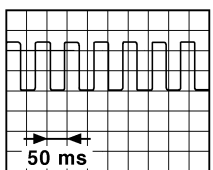
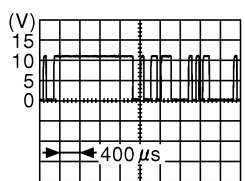
Terminal No. (Wire color)		Description		Condition		Value (Approx.)
+	-	Signal name	Input/ Output			
4 (P)	Ground	Stop lamp switch signal	Input	Ignition switch OFF	Brake pedal is depressed	12 V
					Other than the above	0 V
5 (L)	Ground	Manual mode shift up signal	Input	Ignition switch ON	Selector lever up position	0 V
					Other than the above	12 V
6 (O)	Ground	Paddle shifter up signal	Input	Ignition switch ON	Paddle shifter up operation	0 V
					Other than the above	12 V
7 (GR)	Ground	Communication signal (AMP. → METER)	Output	Ignition switch ON	—	 <p style="text-align: right; font-size: small;">SKIA3362E</p>
8 (L)	Ground	Vehicle speed signal output (2-pulse)	Output	Ignition switch ON	Speedometer operated [When vehicle speed is approx. 40 km/h (25 MPH)]	<p>NOTE: The maximum voltage varies depending on the specification (destination unit).</p>  <p style="text-align: right; font-size: small;">JSNIA0015GB</p>
9 (SB)	Ground	Seat belt buckle switch signal (driver side)	Input	Ignition switch ON	When seat belt (driver side) is fastened	12 V
					When seat belt (driver side) is unfastened	0 V
10 (W)	Ground	Manual mode signal	Input	Ignition switch ON	Selector lever DS position	0 V
					Other than the above	12 V
11 (G)	Ground	Not manual mode signal	Input	Ignition switch ON	Selector lever DS position	12 V
					Other than the above	0 V
14 (BR)	Ground	Communication signal (LCD → AMP.)	Input	Ignition switch ON	—	 <p style="text-align: right; font-size: small;">JSNIA0028GB</p>
25 (V)	Ground	Manual mode shift down signal	Input	Ignition switch ON	Selector lever down position	0 V
					Other than the above	12 V
26 (G)	Ground	Paddle shift down signal	Input	Ignition switch ON	Paddle shifter down operation	0 V
					Other than the above	12 V

UNIFIED METER AND A/C AMP.

< ECU DIAGNOSIS >

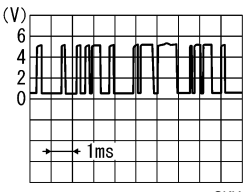
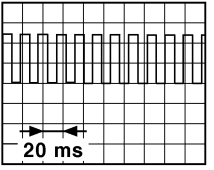
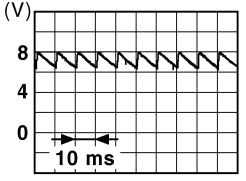
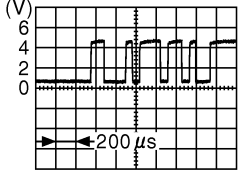
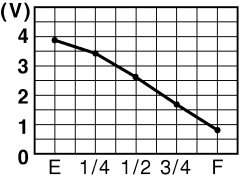
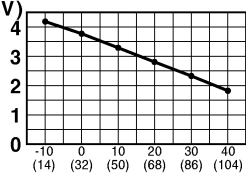
Terminal No. (Wire color)		Description		Condition	Value (Approx.)
+	-	Signal name	Input/ Output		
27 (LG)	Ground	Communication signal (METER → AMP.)	Input	Ignition switch ON	—  SKIA3361E
28 (R)	Ground	Vehicle speed signal output (8-pulse)	Output	Ignition switch ON	Speedometer operated [When vehicle speed is ap- prox. 40 km/h (25 MPH)]  JSNIA0012GB
30 (V)	Ground	Parking brake switch signal	Input	Ignition switch ON	Parking brake applied 0 V
				Ignition switch ON	Parking brake released  JSNIA0007GB
34 (Y)	Ground	Communication signal (AMP. → LCD)	Output	Ignition switch ON	—  JSNIA0027GB
41 (L)	Ground	ACC power supply	Input	Ignition switch ACC	— Battery voltage
42 (BR)	Ground	Fuel level sensor signal	Input	Ignition switch ON	—  JSNIA0013GB
45 (V)	Ground	Ambient sensor signal	Input	—	—  JSNIA0014GB

A
B
C
D
E
F
G
H
I
J
K
L
M
P

WCS

UNIFIED METER AND A/C AMP.

< ECU DIAGNOSIS >

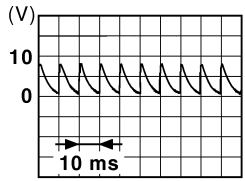
Terminal No. (Wire color)		Description		Condition		Value (Approx.)
+	-	Signal name	Input/ Output			
53 (W)	Ground	Ignition signal	Input	Ignition switch ON	—	Battery voltage
54 (Y)	Ground	Battery power supply	Input	Ignition switch OFF	—	Battery voltage
55 (B)	Ground	Ground	—	Ignition switch ON	—	0 V
56 (L)	Ground	CAN-H	—	—	—	—
57 (BR)	Ground	Brake fluid level switch signal	Input	Ignition switch ON	Brake fluid level is normal.	 <p style="text-align: right; font-size: small;">JSNIA0008GB</p>
					The brake fluid level is lower than the low level	
58 (Y)	Ground	Fuel level sensor signal ground	—	Ignition switch ON	—	0 V
61 (R)	Ground	Ambient sensor signal ground	—	Ignition switch ON	—	0 V
71 (GR)	Ground	Ground	—	Ignition switch ON	—	0 V
72 (P)	Ground	CAN-L	—	—	—	—

UNIFIED METER AND A/C AMP.

< ECU DIAGNOSIS >

Wiring Diagram - METER -

INFOID:000000001696930

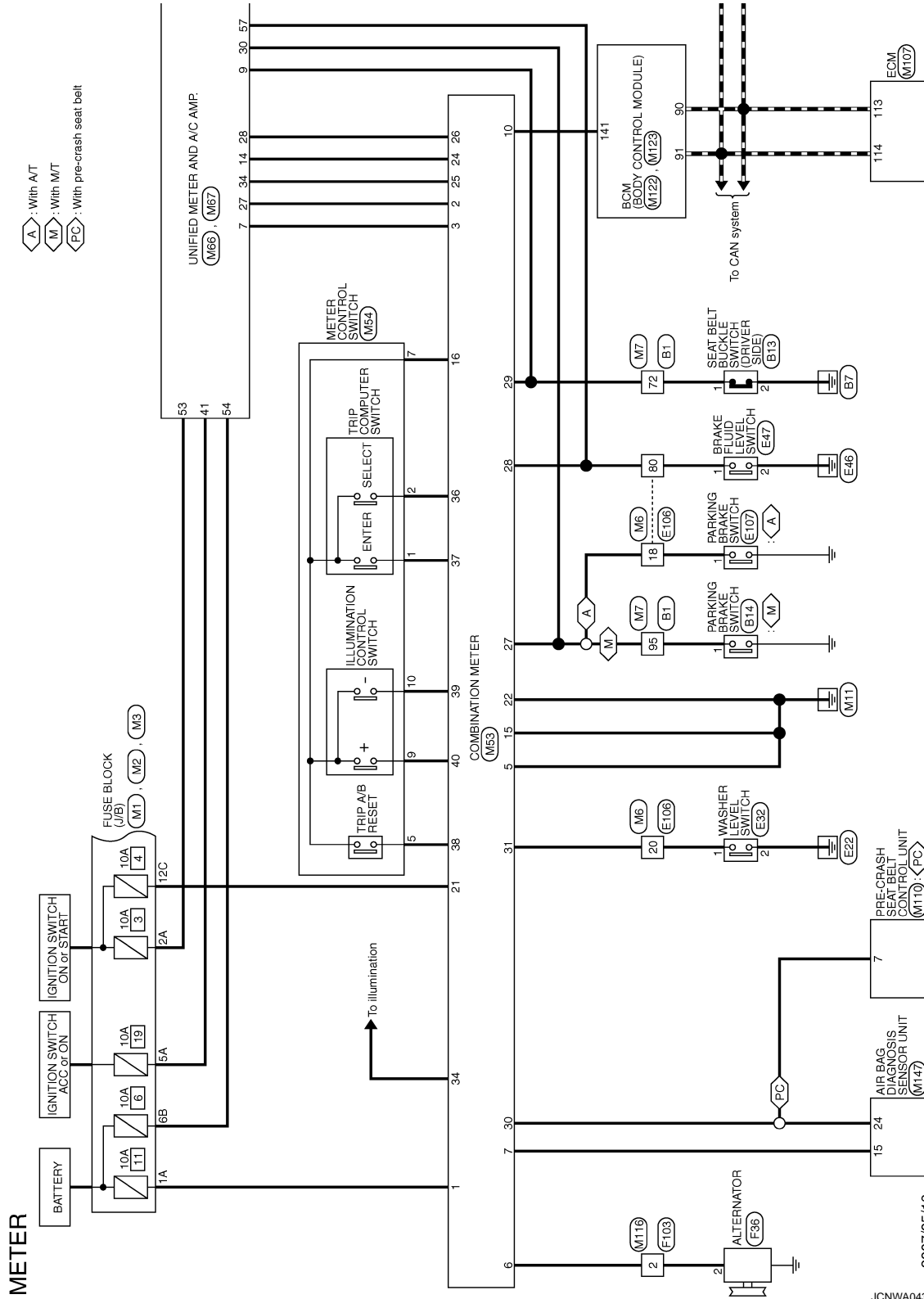

2007/05/18

JCNWA0436GE

A
B
C
D
E
F
G
H
I
J
K
L
M
N
O
P

WCS

UNIFIED METER AND A/C AMP.

< ECU DIAGNOSIS >

- AS : With 4WAS
- WA : With AFS
- NV : With NAVI
- ON : Without NAVI
- IC : With ICC

*: This connector is not shown in "Harness Layout".

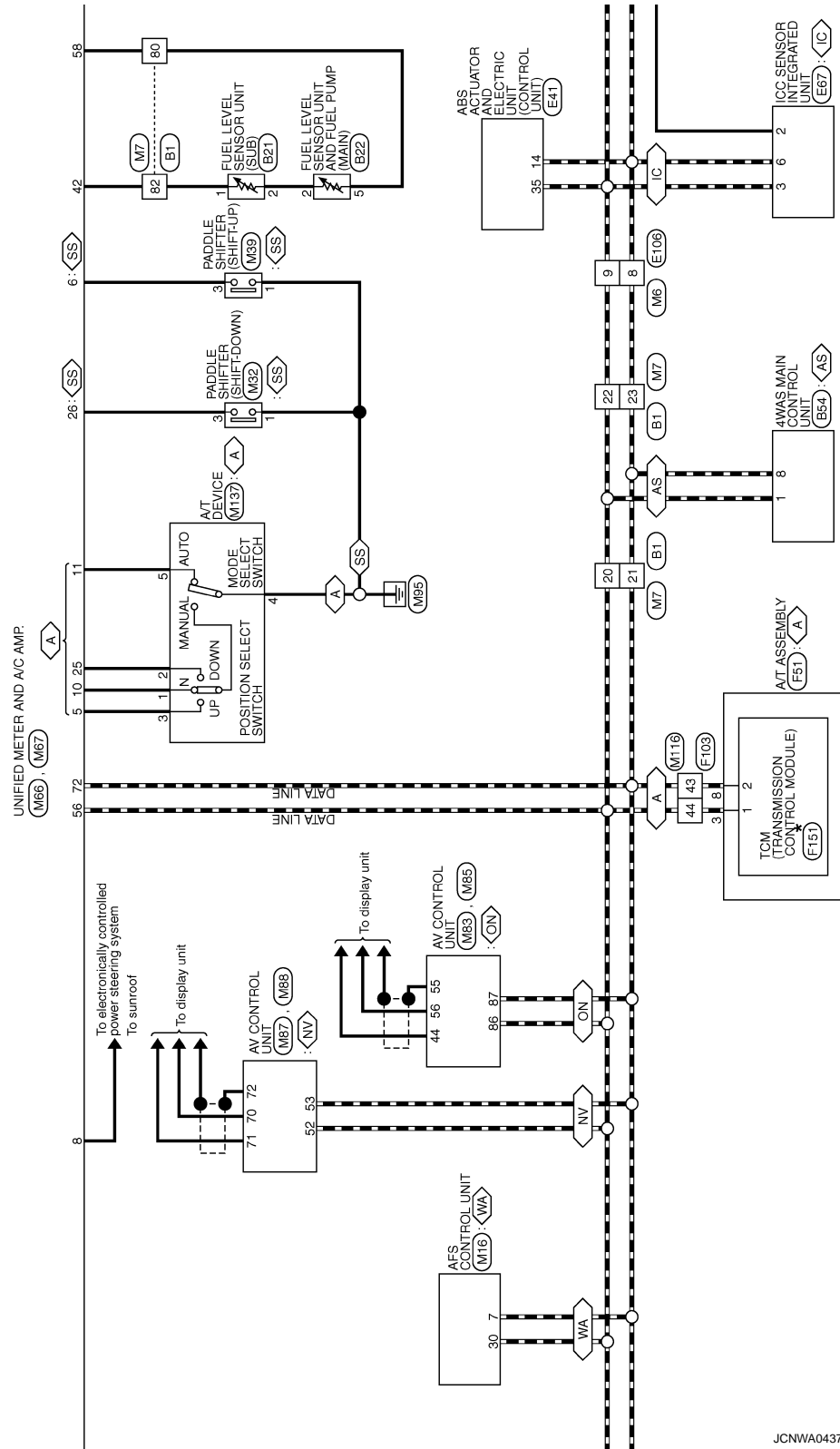

JCNWA0437GE

UNIFIED METER AND A/C AMP.

< ECU DIAGNOSIS >

⬠ : With ICC

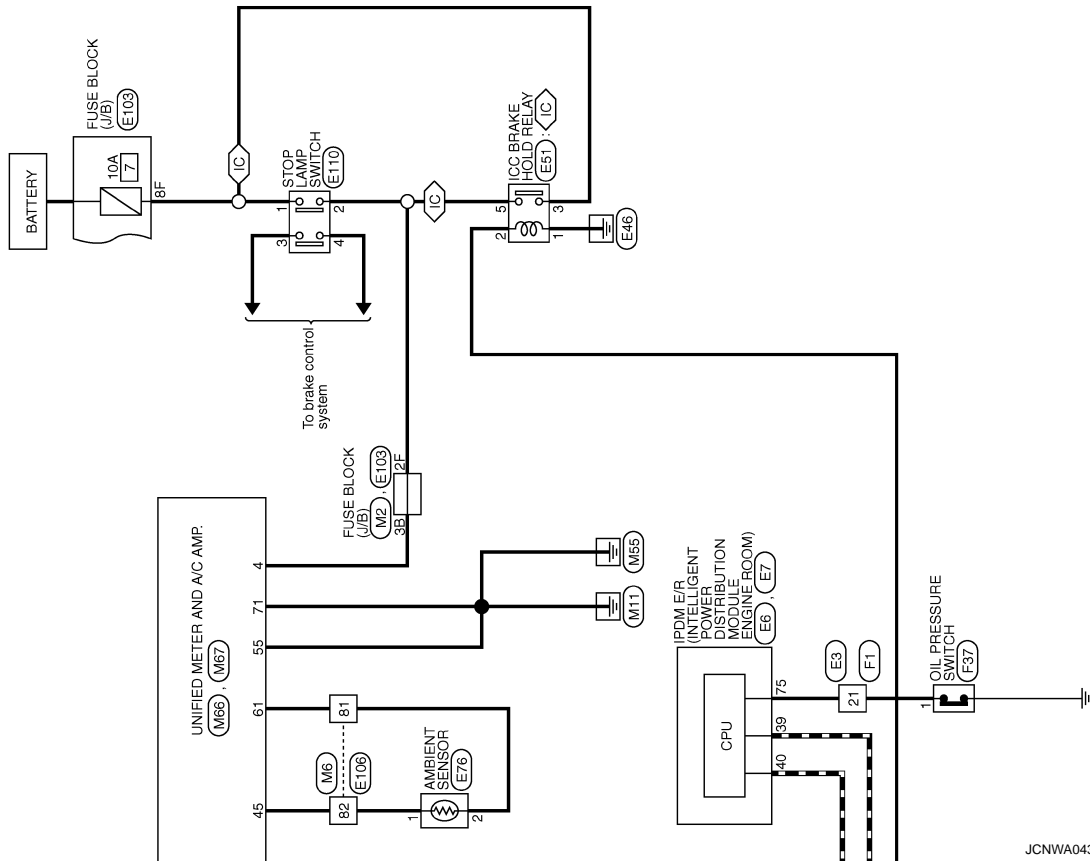

JCNWA0438GE













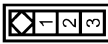

A
B
C
D
E
F
G
H
I
J
K
L
M
N
O
P

WCS

UNIFIED METER AND A/C AMP.

< ECU DIAGNOSIS >

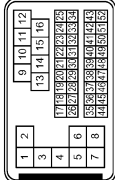
METER

Connector No.	B1	Connector No.	B13	Connector No.	B14	Connector No.	B21
Connector Name	WIRE TO WIRE	SEAT BELT BUCKLE SWITCH (DRIVER SIDE)	PARKING BRAKE SWITCH (M/T)	FUEL LEVEL SENSOR UNIT (SUB)			
Connector Type	TH8DFW-GS16-TM4	A38FW	PO1FB-A	ED2FGY-RS			
							
Terminal No.	20	1	1	1	1	1	1
Color of Wire	L	G	V	B	W	B	W
Signal Name [Specification]							
Terminal No.	21	2	2	2	2	2	2
Color of Wire	P	B					
Signal Name [Specification]							
Terminal No.	22						
Color of Wire	L						
Signal Name [Specification]							
Terminal No.	23						
Color of Wire	P						
Signal Name [Specification]							
Terminal No.	72						
Color of Wire	G						
Signal Name [Specification]							
Terminal No.	80						
Color of Wire	Y						
Signal Name [Specification]							
Terminal No.	82						
Color of Wire	B						
Signal Name [Specification]							
Terminal No.	95						
Color of Wire	V						
Signal Name [Specification]							
Connector No.	B22	Connector No.	B54	Connector No.	E3	Connector No.	E6
Connector Name	FUEL LEVEL SENSOR UNIT AND FUEL PUMP (MAN)	4WAS MAIN CONTROL UNIT	WIRE TO WIRE	FSM L/R (INTELLIGENT POWER DISTRIBUTION MODULE ENGINE ROOM)			
Connector Type	ED8FGY-RS	A38FW-M4	SPA38MB-RSP-SH23	TH8DFW-1H			
							
Terminal No.	2	1	1	1	1	1	1
Color of Wire	W	L	L	V	W	B	W
Signal Name [Specification]							
Terminal No.	3	2	2	2	2	2	2
Color of Wire	Y	P					
Signal Name [Specification]							
Terminal No.	4						
Color of Wire							
Signal Name [Specification]							
Terminal No.	5						
Color of Wire							
Signal Name [Specification]							
Terminal No.	39	21	8	39	39	39	39
Color of Wire	P	S5	P	P	P	P	P
Signal Name [Specification]		CAN-H	CAN-L				
Terminal No.	40			40	40	40	40
Color of Wire	L			L	L	L	L
Signal Name [Specification]							

JCNWA0439GE

UNIFIED METER AND A/C AMP.

< ECU DIAGNOSIS >

METER

Connector No.	E7	Connector No.	E41	Connector No.	E42	Connector No.	E47
Connector Name	IPDM E/R (INTELLIGENT POWER DISTRIBUTION MODULE ENGINE ROOM)	Connector Name	ABS ACTUATOR AND ELECTRIC UNIT (CONTROL UNIT)	Connector Name	WASHER LEVEL SWITCH	Connector Name	BRAKE FLUID LEVEL SWITCH
Connector Type	TH20FW-GS12-IM	Connector Type	BA042EB-AHE24-LH	Connector Type	Z02EBR	Connector Type	Y102EGY

Terminal No.	75	SB	Signal Name [Specification]	Terminal No.	14	P	Signal Name [Specification]	Terminal No.	1	W	Signal Name [Specification]	Terminal No.	1	W	Signal Name [Specification]
					1	LG			2	B			2	B	

Terminal No.	1	B	Signal Name [Specification]	Terminal No.	1	G	Signal Name [Specification]	Terminal No.	2F	W	Signal Name [Specification]
	2	V			2	P			8F	L	
	3	R			6	P					
	5	P									

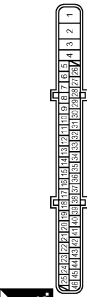

Connector No.	E51	Connector No.	E16	Connector No.	E103
Connector Name	ICC BRAKE HOLD RELAY	Connector Name	AMBIENT SENSOR	Connector Name	FUSE BLOCK (J/B)
Connector Type	MS22FL-M2	Connector Type	RS22FB	Connector Type	NS18FW-GS

Terminal No.	3	5	Signal Name [Specification]	Terminal No.	14	P	Signal Name [Specification]	Terminal No.	1	G	Signal Name [Specification]	Terminal No.	1	G	Signal Name [Specification]
					1	LG			2	P			2	P	
					2	V			6	P			6	P	
					3	L									

Terminal No.	1	B	Signal Name [Specification]	Terminal No.	1	G	Signal Name [Specification]	Terminal No.	1	G	Signal Name [Specification]	Terminal No.	1	G	Signal Name [Specification]
	2	V			2	P			2	P			2	P	
	3	R			6	P									
	5	P													

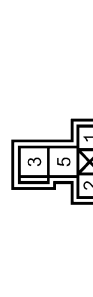
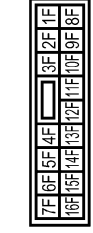

A
B
C
D
E
F
G
H
I
J
K
L
M
O
P

WCS

UNIFIED METER AND A/C AMP.

< ECU DIAGNOSIS >

METER

Connector No.	F1
Connector Name	WIRE TO WIRE
Connector Type	SAA436FB-RS8-SH23

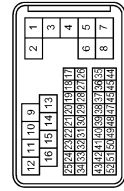

Terminal No.	Color of Wire	Signal Name [Specification]
21	BR	-

Connector No.	E110
Connector Name	STOP LAMP SWITCH
Connector Type	MG4FW-LC



Terminal No.	Color of Wire	Signal Name [Specification]
1	L	-
2	W	-
3	L	-
4	SB	-

Connector No.	E107
Connector Name	PARKING BRAKE SWITCH (A/T)
Connector Type	TE01FW



Terminal No.	Color of Wire	Signal Name [Specification]
1	O	-

Connector No.	E106
Connector Name	WIRE TO WIRE
Connector Type	TH80FW-GS16-TM4

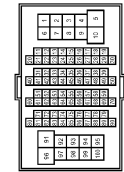

Terminal No.	Color of Wire	Signal Name [Specification]
8	P	-
9	L	-
18	O	-
20	LG	-
80	W	-
81	P	-
82	G	-

Connector No.	F103
Connector Name	WIRE TO WIRE
Connector Type	TK38FW-NS10

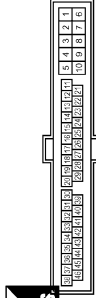

Terminal No.	Color of Wire	Signal Name [Specification]
2	G	-
43	P	-
44	L	-

Connector No.	F51
Connector Name	A/T ASSEMBLY
Connector Type	PK10FG-DGY

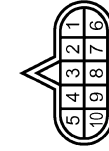

Terminal No.	Color of Wire	Signal Name [Specification]
3	L	-
8	P	-

Connector No.	F37
Connector Name	OIL PRESSURE SWITCH
Connector Type	ED1FGY-RS-AR



Terminal No.	Color of Wire	Signal Name [Specification]
1	BR	-

Connector No.	F36
Connector Name	ALTERNATOR
Connector Type	HS03FB



Terminal No.	Color of Wire	Signal Name [Specification]
2	G	L

JCNWA0441GE

UNIFIED METER AND A/C AMP.

< ECU DIAGNOSIS >

METER

Connector No.	F1B1
Connector Name	TOM (TRANSMISSION CONTROL MODULE)
Connector Type	SP10FBGY

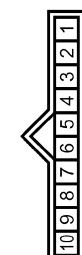

Terminal No.	Color of Wire	Signal Name [Specification]
1	BR	CAN-H
2	L/Y	CAN-L

Connector No.	M1
Connector Name	FUSE BLOCK (J/B)
Connector Type	NS06FW-M2

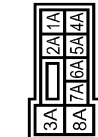

Terminal No.	Color of Wire	Signal Name [Specification]
1A	V	-
2A	G	-
5A	L	-

Connector No.	M2
Connector Name	FUSE BLOCK (J/B)
Connector Type	NS10FW-CS



Terminal No.	Color of Wire	Signal Name [Specification]
3B	P	-
6B	Y	-

Connector No.	M3
Connector Name	FUSE BLOCK (J/B)
Connector Type	NS12FW-CS

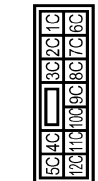

Terminal No.	Color of Wire	Signal Name [Specification]
12C	R	-

Connector No.	M8
Connector Name	WIRE TO WIRE
Connector Type	TH80MW-CS16-TM4

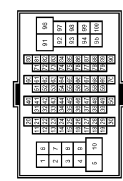

Terminal No.	Color of Wire	Signal Name [Specification]
8	P	-
9	L	-
18	O	-
20	L	-
80	LG	-
81	R	-
82	V	-

Connector No.	M7
Connector Name	WIRE TO WIRE
Connector Type	TH80MW-CS16-TM4

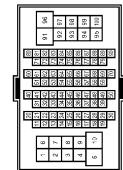

Terminal No.	Color of Wire	Signal Name [Specification]
20	L	-
21	P	-
22	L	-
23	P	-
72	L	- [With A/T]
72	LG	- [With M/T]
80	V	-
82	BR	-
98	O	-

Connector No.	M16
Connector Name	AFS CONTROL UNIT
Connector Type	TH40FW-NH

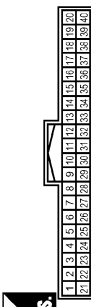

Terminal No.	Color of Wire	Signal Name [Specification]
7	P	CAN-L
30	L	CAN-H

Connector No.	M32
Connector Name	PADDLE SHIFTER (SHIFT-DOWN)
Connector Type	AS3FW

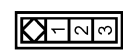

Terminal No.	Color of Wire	Signal Name [Specification]
1	W	-
3	G	-

A
B
C
D
E
F
G
H
I
J
K
L
M
WCS
O
P

UNIFIED METER AND A/C AMP.

< ECU DIAGNOSIS >

METER

Connector No.	M39
Connector Name	PADDLE SHIFTER (SHIFT-UP)
Connector Type	TH4FW



Terminal No.	Color of Wire	Signal Name [Specification]
1	P	-
3	O	-

Connector No.	M53
Connector Name	COMBINATION METER
Connector Type	SAB40FW

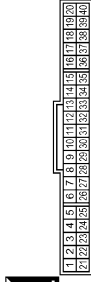

Terminal No.	Color of Wire	Signal Name [Specification]
1	V	BAT
2	LG	COMM (METER->AMP)
3	GR	COMM (AMP->METER)
5	B	GND
6	W	ALTERNATOR
7	LG	AIR BAG
10	R	SECURITY
15	B	GND
16	B	METER CONTROL SW GND
21	R	IGN
22	B	GND

24	BR	COMM (LCD->AMP)
25	Y	COMM (AMP->LCD)
26	R	VEHICLE SPEED (8-PULSE)
27	O	PARKING BRAKE SW
28	LG	BRAKE FLUID LEVEL SW
29	L	SEAT BELT BUCKLE SW (DRIVER SIDE) [With A/T]
29	LG	SEAT BELT BUCKLE SW (DRIVER SIDE) [With M/T]
30	G	SEAT BELT
31	L	WASHER LEVEL SW
34	R	ILLUMINATION CONTROL
36	LG	SELECT SW
37	SB	ENTER SW
38	L	TRIP A/B RESET SW
39	P	ILLUMINATION CONTROL SW (-)
40	O	ILLUMINATION CONTROL SW (+)

Connector No.	M54
Connector Name	METER CONTROL SWITCH
Connector Type	TH12FW-NH

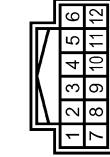

Terminal No.	Color of Wire	Signal Name [Specification]
1	SB	-
2	LG	-
5	L	-
7	B	-
9	O	-
10	P	-

Connector No.	M68
Connector Name	UNIFIED METER AND A/C AMP.
Connector Type	TH40FW-NH

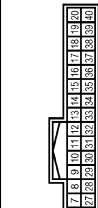

Terminal No.	Color of Wire	Signal Name [Specification]
4	P	STOP LAMP SW
5	L	SHIFT UP SW
6	O	PADDLE UP
7	GR	COMM (AMP->METER)
8	L	VEHICLE SPEED (2-PULSE)
9	SB	SEAT BELT BUCKLE SW (DRIVER SIDE)
10	W	MANUAL MODE SW
11	G	AUTO MODE SW
14	BR	COMM (LCD->AMP)
25	V	SHIFT DOWN SW
26	G	PADDLE DOWN

Connector No.	M67
Connector Name	UNIFIED METER AND A/C AMP.
Connector Type	TH432FW-NH

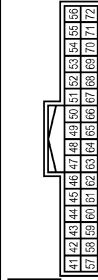

Terminal No.	Color of Wire	Signal Name [Specification]
41	L	ACC
42	BR	FUEL LEVEL SENS
45	V	AMB SENS
53	W	IGN
54	Y	BAT
55	B	GND
56	L	CAN-H
57	BR	BRAKE FLUID LEVEL SW
58	Y	FUEL LEVEL SENS GND
61	R	AMB SENS GND
71	GR	GND

72	P	CAN-L
----	---	-------

UNIFIED METER AND A/C AMP.

< ECU DIAGNOSIS >

METER

Connector No.	M83
Connector Name	AV CONTROL UNIT (WITHOUT NAVI)
Connector Type	TH24FW-NH

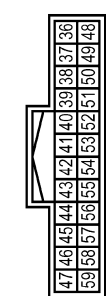

Terminal No.	Color of Wire	Signal Name [Specification]
44	G	COMM (DISP->CONT)
55	SHIELD	SHIELD
56	L	COMM (CONT->DISP)

Connector No.	M84
Connector Name	AV CONTROL UNIT (WITH NAVI)
Connector Type	TH12FW-NH

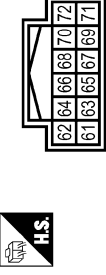

Terminal No.	Color of Wire	Signal Name [Specification]
70	BR	COMM (CONT->DISP)
71	Y	COMM (DISP->CONT)
72	SHIELD	SHIELD

Connector No.	M85
Connector Name	AV CONTROL UNIT (WITHOUT NAVI)
Connector Type	TH32FW-NH

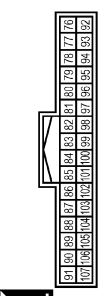

Terminal No.	Color of Wire	Signal Name [Specification]
86	L	CAN-H
87	P	CAN-L

Connector No.	M87
Connector Name	AV CONTROL UNIT (WITH NAVI)
Connector Type	TH40FW-NH

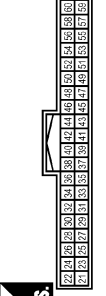

Terminal No.	Color of Wire	Signal Name [Specification]
52	L	CAN-H
53	P	CAN-L

Connector No.	M88
Connector Name	AV CONTROL UNIT (WITH NAVI)
Connector Type	TH12FW-NH

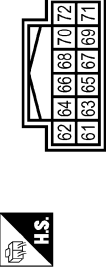

Terminal No.	Color of Wire	Signal Name [Specification]
70	BR	COMM (CONT->DISP)
71	Y	COMM (DISP->CONT)
72	SHIELD	SHIELD

Connector No.	M107
Connector Name	ECM
Connector Type	RH24FGV-R28-R-LH-Z

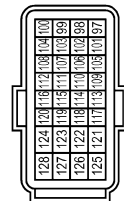

Terminal No.	Color of Wire	Signal Name [Specification]
113	P	VEHCAN-L1
114	L	VEHCAN-H1

Connector No.	M110
Connector Name	PRE-CRASH SEAT BELT CONTROL UNIT
Connector Type	TH20FW-TB6

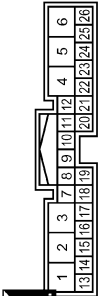

Terminal No.	Color of Wire	Signal Name [Specification]
7	G	INDICATOR

Connector No.	M116
Connector Name	WIRE TO WIRE
Connector Type	TK38MW-NS10

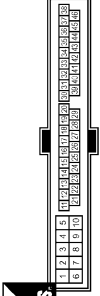

Terminal No.	Color of Wire	Signal Name [Specification]
2	W	-
43	P	-
44	L	-

Connector No.	M122
Connector Name	BCM (BODY CONTROL MODULE)
Connector Type	TH40FB-NH

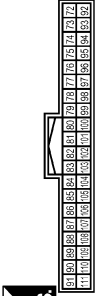

Terminal No.	Color of Wire	Signal Name [Specification]
90	P	CAN-L
91	L	CAN-H

A
B
C
D
E
F
G
H
I
J
K
L
M
O
P

WCS

JCNWA0444GE

UNIFIED METER AND A/C AMP.

< ECU DIAGNOSIS >

METER

Connector No.	M123
Connector Name	BOM (BODY CONTROL MODULE)
Connector Type	TH4FG-NH

Terminal No.	Color of Wire	Signal Name [Specification]
141	R	SECURITY INDICATOR OUTPUT

Connector No.	M137
Connector Name	A/T DEVICE
Connector Type	TH12FW-NH

Terminal No.	Color of Wire	Signal Name [Specification]
1	W	-
2	V	-
3	L	-
4	BR	-
5	G	-

Connector No.	M147
Connector Name	AIR BAG DIAGNOSIS SENSOR UNIT
Connector Type	TK28FY-EX-SC

Terminal No.	Color of Wire	Signal Name [Specification]
15	LG	AIR BAG W/L
24	G	SEAT BELT

JCNWA0445GE

Fail Safe

INFOID:000000001677402

FAIL SAFE

The unified meter and A/C amp. activates the fail-safe control if CAN communication with each unit is malfunctioning.

UNIFIED METER AND A/C AMP.

< ECU DIAGNOSIS >

Function	Specifications	
Speedometer	Reset to zero by suspending communication.	
Tachometer		
Fuel gauge	Indicates fuel level	
Water temperature gauge	Reset to zero by suspending communication.	
Illumination control	When suspending communication, change to nighttime mode.	
Information display	The display turns off by suspending communication.	
Buzzer	The buzzer turns off by suspending communication.	
Warning lamp/indicator lamp	ABS warning lamp	The lamp turns on by suspending communication.
	VDC OFF indicator lamp	
	SLIP indicator lamp	
	Brake warning lamp	
	CRUISE warning lamp	
	Master warning lamp	
	Low tire pressure warning lamp	The lamp turns ON after flashing for 1 minute.
	AFS OFF indicator lamp	The lamp blinking caused by communication malfunction
	High beam indicator	The lamp turns off by suspending communication.
	4WAS warning lamp	
	Turn signal indicator lamp	
	Front fog indicator lamp	
	Oil pressure warning lamp	
	Malfunction indicator lamp	
A/T CHECK warning lamp		
Key warning lamp		

DTC Index

INFOID:000000001677403

Display contents of CONSULT-III	Time		Diagnostic item is detected when...	Refer to
U1000: CAN COMM CIRCUIT	CRNT	PAST	When unified meter and A/C amp. is not transmitting or receiving CAN communication signal for 2 seconds or more.	MWI-41
U1010: CONTROL UNIT (CAN)	CRNT	PAST	When detecting error during the initial diagnosis of CAN controller of unified meter and A/C amp.	MWI-42
B2201: COMM ERROR 1	CRNT	PAST	If a communication error is present in the communication line between unified meter and A/C amp. and combination meter for 2 seconds or more.	MWI-43
B2202: COMM ERROR 2	CRNT	PAST	If a communication error is present in the communication line between unified meter and A/C amp. and combination meter for 2 seconds or more.	MWI-45
B2205: VEHICLE SPEED	CRNT	PAST	The abnormal vehicle speed signal is input from ABS actuator and electric unit (control unit) for 2 seconds or more.	MWI-47
B2267: ENGINE SPEED	CRNT	PAST	If ECM continuously transmits abnormal engine speed signals for 2 seconds or more.	MWI-48
B2268: WATER TEMP	CRNT	PAST	If ECM continuously transmits abnormal engine coolant temperature signals for 60 seconds or more.	MWI-49

NOTE:

The details of TIME display are as follows.

- CRNT: The malfunctions that are detected now.
- PAST: The malfunctions was detected in the past. IGN counter is displayed on FFD (Freeze Frame data).

UNIFIED METER AND A/C AMP.

< ECU DIAGNOSIS >

- 1 - 39: The number is indicated when it is normal at present and a malfunction was detected in the past. It increases like 0 → 1 → 2 ... 38 → 39 after returning to the normal condition whenever IGN OFF → ON. It is fixed to 39 until the self-diagnosis results are erased if it is over 39. It returns to 0 when a malfunction is detected again in the process.

BCM (BODY CONTROL MODULE)

< ECU DIAGNOSIS >

BCM (BODY CONTROL MODULE)

Reference Value

INFOID:000000001889423

VALUES ON THE DIAGNOSIS TOOL

CONSULT-III MONITOR ITEM

Monitor Item	Condition	Value/Status
FR WIPER HI	Other than front wiper switch HI	Off
	Front wiper switch HI	On
FR WIPER LOW	Other than front wiper switch LO	Off
	Front wiper switch LO	On
FR WASHER SW	Front washer switch OFF	Off
	Front washer switch ON	On
FR WIPER INT	Other than front wiper switch INT	Off
	Front wiper switch INT	On
FR WIPER STOP	Front wiper is not in STOP position	Off
	Front wiper is in STOP position	On
INT VOLUME	Wiper intermittent dial is in a dial position 1 - 7	Wiper intermittent dial position
TURN SIGNAL R	Other than turn signal switch RH	Off
	Turn signal switch RH	On
TURN SIGNAL L	Other than turn signal switch LH	Off
	Turn signal switch LH	On
TAIL LAMP SW	Other than lighting switch 1ST and 2ND	Off
	Lighting switch 1ST or 2ND	On
HI BEAM SW	Other than lighting switch HI	Off
	Lighting switch HI	On
HEAD LAMP SW 1	Other than lighting switch 2ND	Off
	Lighting switch 2ND	On
HEAD LAMP SW 2	Other than lighting switch 2ND	Off
	Lighting switch 2ND	On
PASSING SW	Other than lighting switch PASS	Off
	Lighting switch PASS	On
AUTO LIGHT SW	Other than lighting switch AUTO	Off
	Lighting switch AUTO	On
FR FOG SW	Front fog lamp switch OFF	Off
	Front fog lamp switch ON	On
RR FOG SW	NOTE: The item is indicated, but not monitored.	Off
DOOR SW-DR	Driver door closed	Off
	Driver door opened	On
DOOR SW-AS	Passenger door closed	Off
	Passenger door opened	On
DOOR SW-RR	NOTE: The item is indicated, but not monitored.	Off
DOOR SW-RL	NOTE: The item is indicated, but not monitored.	Off

A

B

C

D

E

F

G

H

I

J

K

L

M

WCS

O

P

BCM (BODY CONTROL MODULE)

< ECU DIAGNOSIS >

Monitor Item	Condition	Value/Status
DOOR SW-BK	NOTE: The item is indicated, but not monitored.	Off
CDL LOCK SW	Other than power door lock switch LOCK	Off
	Power door lock switch LOCK	On
CDL UNLOCK SW	Other than power door lock switch UNLOCK	Off
	Power door lock switch UNLOCK	On
KEY CYL LK-SW	Other than driver door key cylinder LOCK position	Off
	Driver door key cylinder LOCK position	On
KEY CYL UN-SW	Other than driver door key cylinder UNLOCK position	Off
	Driver door key cylinder UNLOCK position	On
KEY CYL SW-TR	NOTE: The item is indicated, but not monitored.	Off
HAZARD SW	Hazard switch is not pressed	Off
	Hazard switch is pressed	On
REAR DEF SW	NOTE: The item is indicated, but not monitored.	Off
H/L WASH SW	NOTE: The item is indicated, but not monitored.	Off
TR CANCEL SW	Trunk lid opener cancel switch OFF	Off
	Trunk lid opener cancel switch ON	On
TR/BD OPEN SW	Trunk lid opener switch OFF	Off
	While the trunk lid opener switch is turned ON	On
TRNK/HAT MNTR	Trunk lid closed	Off
	Trunk lid opened	On
RKE-LOCK	LOCK button of Intelligent Key is not pressed	Off
	LOCK button of Intelligent Key is pressed	On
RKE-UNLOCK	UNLOCK button of Intelligent Key is not pressed	Off
	UNLOCK button of Intelligent Key is pressed	On
RKE-TR/BD	TRUNK OPEN button of Intelligent Key is not pressed	Off
	TRUNK OPEN button of Intelligent Key is pressed	On
RKE-PANIC	PANIC button of Intelligent Key is not pressed	Off
	PANIC button of Intelligent Key is pressed	On
RKE-P/W OPEN	UNLOCK button of Intelligent Key is not pressed	Off
	UNLOCK button of Intelligent Key is pressed and held	On
RKE-MODE CHG	LOCK/UNLOCK button of Intelligent Key is not pressed and held simultaneously	Off
	LOCK/UNLOCK button of Intelligent Key is pressed and held simultaneously	On
OPTICAL SENSOR	Bright outside of the vehicle	Close to 5 V
	Dark outside of the vehicle	Close to 0 V
REQ SW-DR	Driver door request switch is not pressed	Off
	Driver door request switch is pressed	On
REQ SW-AS	Passenger door request switch is not pressed	Off
	Passenger door request switch is pressed	On
REQ SW-BD/TR	Trunk request switch is not pressed	Off
	Trunk request switch is pressed	On

BCM (BODY CONTROL MODULE)

< ECU DIAGNOSIS >

Monitor Item	Condition	Value/Status	
PUSH SW	Push-button ignition switch (push switch) is not pressed	Off	A
	Push-button ignition switch (push switch) is pressed	On	
IGN RLY2 -F/B	Ignition switch in OFF or ACC position	Off	B
	Ignition switch in ON position	On	
ACC RLY -F/B	Ignition switch in OFF position	Off	C
	Ignition switch in ACC or ON position	On	
CLUCH SW	The clutch pedal is not depressed	Off	D
	The clutch pedal is depressed	On	
BRAKE SW 1	The brake pedal is not depressed	On	E
	The brake pedal is depressed	Off	
DETE/CANCL SW	Selector lever in P position	Off	F
	Selector lever in any position other than P	On	
SFT PN/N SW	Selector lever in any position other than P and N	Off	G
	Selector lever in P or N position	On	
S/L -LOCK	Steering is locked	Off	H
	Steering is unlocked	On	
S/L -UNLOCK	Steering is unlocked	Off	I
	Steering is locked	On	
S/L RELAY-F/B	Ignition switch in OFF or ACC position	Off	J
	Ignition switch in ON position	On	
UNLK SEN-DR	Driver door is unlocked	Off	K
	Driver door is locked	On	
PUSH SW -IPDM	Push-button ignition switch (push-switch) is not pressed	Off	L
	Push-button ignition switch (push-switch) is pressed	On	
IGN RLY1 -F/B	Ignition switch in OFF or ACC position	Off	M
	Ignition switch in ON position	On	
DETE SW -IPDM	Selector lever in P position	Off	WCS
	Selector lever in any position other than P	On	
SFT PN -IPDM	Selector lever in any position other than P and N	Off	O
	Selector lever in P or N position	On	
SFT P -MET	Selector lever in any position other than P	Off	P
	Selector lever in P position	On	
SFT N -MET	Selector lever in any position other than N	Off	
	Selector lever in N position	On	
ENGINE STATE	Engine stopped	Stop	
	While the engine stalls	Stall	
	At engine cranking	Crank	
	Engine running	Run	
S/L LOCK-IPDM	Steering is locked	Off	
	Steering is unlocked	On	
S/L UNLK-IPDM	Steering is unlocked	Off	
	Steering is locked	On	
S/L RELAY-REQ	Ignition switch in OFF or ACC position	Off	
	Ignition switch in ON position	On	

BCM (BODY CONTROL MODULE)

< ECU DIAGNOSIS >

Monitor Item	Condition	Value/Status
VEH SPEED 1	While driving	Equivalent to speedometer reading
VEH SPEED 2	While driving	Equivalent to speedometer reading
DR DOOR STATE	Driver door is locked	LOCK
	Wait with selective UNLOCK operation (5 seconds)	READY
	Driver door is unlocked	UNLK
AR DOOR STATE	Passenger door is locked	LOCK
	Wait with selective UNLOCK operation (5 seconds)	READY
	Passenger door is unlocked	UNLK
ID OK FLAG	Ignition switch in ACC or ON position	Reset
	Ignition switch in OFF position	Set
PRMT ENG STRT	The engine start is prohibited	Reset
	The engine start is permitted	Set
PRMT RKE STRT	NOTE: The item is indicated, but not monitored.	Reset
KEY SW -SLOT	Intelligent Key is not inserted into key slot	Off
	Intelligent Key is inserted into key slot	On
RKE OPE COUN1	During the operation of Intelligent Key	Operation frequency of Intelligent Key
RKE OPE COUN2	NOTE: The item is indicated, but not monitored.	—
CONFIRM ID ALL	The key ID that the key slot receives does not accord with any key ID registered to BCM.	Yet
	The key ID that the key slot receives accords with any key ID registered to BCM.	DONE
CONFIRM ID4	The key ID that the key slot receives does not accord with the fourth key ID registered to BCM.	Yet
	The key ID that the key slot receives accords with the fourth key ID registered to BCM.	DONE
CONFIRM ID3	The key ID that the key slot receives does not accord with the third key ID registered to BCM.	Yet
	The key ID that the key slot receives accords with the third key ID registered to BCM.	DONE
CONFIRM ID2	The key ID that the key slot receives does not accord with the second key ID registered to BCM.	Yet
	The key ID that the key slot receives accords with the second key ID registered to BCM.	DONE
CONFIRM ID1	The key ID that the key slot receives does not accord with the first key ID registered to BCM.	Yet
	The key ID that the key slot receives accords with the first key ID registered to BCM.	DONE
TP 4	The ID of fourth Intelligent Key is not registered to BCM	Yet
	The ID of fourth Intelligent Key is registered to BCM	DONE
TP 3	The ID of third Intelligent Key is not registered to BCM	Yet
	The ID of third Intelligent Key is registered to BCM	DONE
TP 2	The ID of second Intelligent Key is not registered to BCM	Yet
	The ID of second Intelligent Key is registered to BCM	DONE
TP 1	The ID of first Intelligent Key is not registered to BCM	Yet
	The ID of first Intelligent Key is registered to BCM	DONE

BCM (BODY CONTROL MODULE)

< ECU DIAGNOSIS >

Monitor Item	Condition	Value/Status	
AIR PRESS FL	Ignition switch ON (Only when the signal from the transmitter is received)	Air pressure of front LH tire	A
AIR PRESS FR	Ignition switch ON (Only when the signal from the transmitter is received)	Air pressure of front RH tire	B
AIR PRESS RR	Ignition switch ON (Only when the signal from the transmitter is received)	Air pressure of rear RH tire	C
AIR PRESS RL	Ignition switch ON (Only when the signal from the transmitter is received)	Air pressure of rear LH tire	
ID REGST FL1	ID of front LH tire transmitter is registered	Green	D
	ID of front LH tire transmitter is not registered	Red	
ID REGST FR1	ID of front RH tire transmitter is registered	Green	E
	ID of front RH tire transmitter is not registered	Red	
ID REGST RR1	ID of rear RH tire transmitter is registered	Green	F
	ID of rear RH tire transmitter is not registered	Red	
ID REGST RL1	ID of rear LH tire transmitter is registered	Green	G
	ID of rear LH tire transmitter is not registered	Red	
WARNING LAMP	Tire pressure indicator OFF	Off	H
	Tire pressure indicator ON	On	
BUZZER	Tire pressure warning alarm is not sounding	Off	I
	Tire pressure warning alarm is sounding	On	

A
B
C
D
E
F
G
H
I
J
K
L
M
O
P

WCS

BCM (BODY CONTROL MODULE)

< ECU DIAGNOSIS >
 TERMINAL LAYOUT

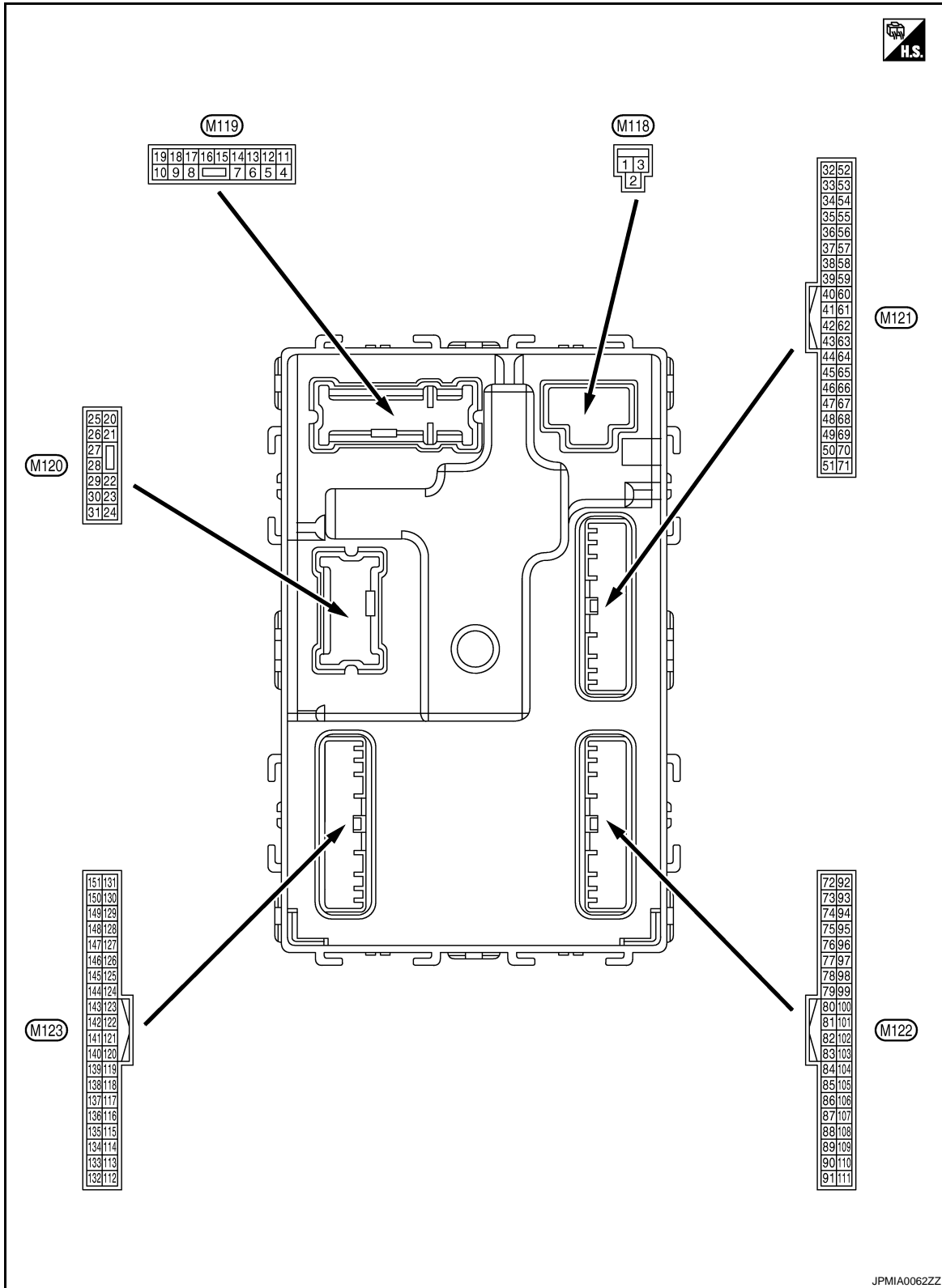

PHYSICAL VALUES

BCM (BODY CONTROL MODULE)

< ECU DIAGNOSIS >

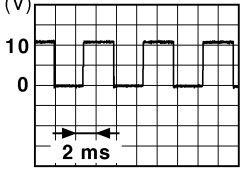
Terminal No. (Wire color)		Description		Condition		Value (Approx.)
		Signal name	Input/ Output			
+	-					
1 (W)	Ground	Battery power supply	Input	Ignition switch OFF		Battery voltage
2 (Y)	Ground	P/W power supply (BAT)	Output	Ignition switch OFF		Battery voltage
3 (Y)	Ground	P/W power supply (RAP)	Output	Ignition switch ON		Battery voltage
4 (LG)	Ground	Interior room lamp power supply	Output	After passing the interior room lamp battery saver operation time		0 V
				Any other time after passing the interior room lamp battery saver operation time		Battery voltage
5 (P)	Ground	Passenger door UN- LOCK	Output	Passenger door	UNLOCK (Actuator is activated)	Battery voltage
					Other than UNLOCK (Actuator is not activated)	0 V
7 (Y)	Ground	Step lamp	Output	Step lamp	ON	0 V
					OFF	Battery voltage
8 (V)	Ground	All doors, fuel lid LOCK	Output	All doors, fuel lid	LOCK (Actuator is activated)	Battery voltage
					Other than LOCK (Actuator is not activated)	0 V
9 (G)	Ground	Driver door, fuel lid UNLOCK	Output	Driver door, fuel lid	UNLOCK (Actuator is activated)	Battery voltage
					Other than UNLOCK (Actuator is not activated)	0 V
11 (R)	Ground	Battery power supply	Input	Ignition switch OFF		Battery voltage
13 (B)	Ground	Ground	—	Ignition switch ON		0 V
14 (W)	Ground	Push-button ignition switch illumination ground	Output	Tail lamp	OFF	0 V
					ON	<p>NOTE: When the illumination brightening/dimming level is in the neutral position</p>  <p style="text-align: right; font-size: small;">JSNIA0010GB</p>
15 (O)	Ground	ACC indicator lamp	Output	Ignition switch	OFF	Battery voltage
					ACC or ON	0 V

A
B
C
D
E
F
G
H
I
J
K
L
M
O
P

WCS

BCM (BODY CONTROL MODULE)

< ECU DIAGNOSIS >

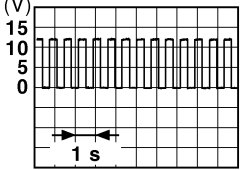
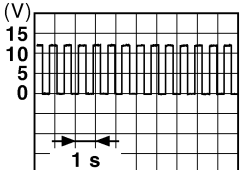
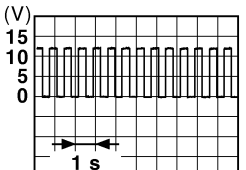
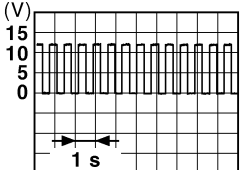
Terminal No. (Wire color)		Description		Condition	Value (Approx.)	
+	-	Signal name	Input/ Output			
17 (V)	Ground	Turn signal (front RH)	Output	Ignition switch ON	Turn signal switch OFF	0 V
				Turn signal switch RH	 <p style="text-align: right;">PKID0926E 6.5 V</p>	
18 (G)	Ground	Turn signal (front LH)	Output	Ignition switch ON	Turn signal switch OFF	0 V
				Turn signal switch LH	 <p style="text-align: right;">PKID0926E 6.5 V</p>	
19 (V)	Ground	Room lamp timer control	Output	Interior room lamp	OFF	Battery voltage
				ON	0 V	
20 (V)	Ground	Turn signal (rear RH)	Output	Ignition switch ON	Turn signal switch OFF	0 V
				Turn signal switch RH	 <p style="text-align: right;">PKID0926E 6.5 V</p>	
23 (G)	Ground	Trunk lid opening.	Output	Trunk lid	Open (Trunk lid opener ac- tuator is activated)	Battery voltage
				Close (Trunk lid opener ac- tuator is not activated)	0 V	
25 (G)	Ground	Turn signal (rear LH)	Output	Ignition switch ON	Turn signal switch OFF	0 V
				Turn signal switch LH	 <p style="text-align: right;">PKID0926E 6.5 V</p>	
30 (R)	Ground	Trunk room lamp	Output	Trunk room lamp	ON	0 V
				OFF	Battery voltage	

BCM (BODY CONTROL MODULE)

< ECU DIAGNOSIS >

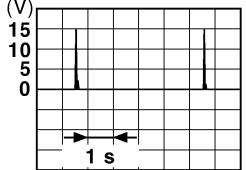
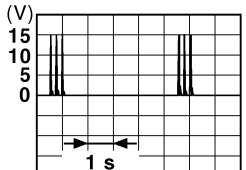
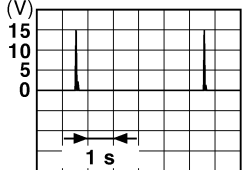
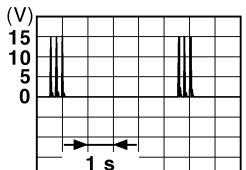
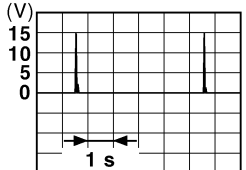
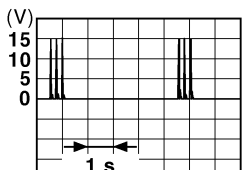
Terminal No. (Wire color)		Description		Condition	Value (Approx.)
		Signal name	Input/ Output		
+	-				
34 (SB)	Ground	Trunk room antenna 1 (-)	Output	Ignition switch OFF	 <p style="text-align: right; font-size: small;">JMKIA0062GB</p>
				When Intelligent Key is not in the passenger compart- ment	 <p style="text-align: right; font-size: small;">JMKIA0063GB</p>
35 (V)	Ground	Trunk room antenna 1 (+)	Output	Ignition switch OFF	 <p style="text-align: right; font-size: small;">JMKIA0062GB</p>
				When Intelligent Key is not in the passenger compart- ment	 <p style="text-align: right; font-size: small;">JMKIA0063GB</p>
38 (B)	Ground	Rear bumper anten- na (-)	Output	When the trunk lid request switch is operated with ignition switch OFF	 <p style="text-align: right; font-size: small;">JMKIA0062GB</p>
				When Intelligent Key is not in the antenna detection area	 <p style="text-align: right; font-size: small;">JMKIA0063GB</p>

A
B
C
D
E
F
G
H
I
J
K
L
M
O
P

WCS

BCM (BODY CONTROL MODULE)

< ECU DIAGNOSIS >

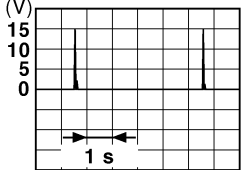
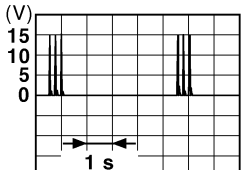
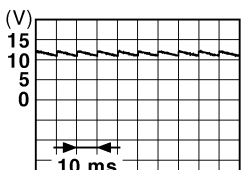
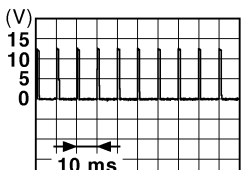
Terminal No. (Wire color)		Description		Condition		Value (Approx.)
+	-	Signal name	Input/ Output			
39 (W)	Ground	Rear bumper antenna (+)	Output	When the trunk lid request switch is operated with ignition switch OFF	When Intelligent Key is in the antenna detection area	 JMKIA0062GB
					When Intelligent Key is not in the antenna detection area	 JMKIA0063GB
47 (Y)	Ground	Ignition relay (IPDM E/R) control	Output	Ignition switch	OFF or ACC	Battery voltage
					ON	0 V
50 (R)	Ground	Trunk room lamp switch	Input	Trunk room lamp switch	OFF (Trunk is closed)	 11.8 V JPMIA0011GB
					ON (Trunk is open)	0 V
52 (SB)	Ground	Starter relay control	Output	Ignition switch OFF (M/T models)	When the clutch pedal is depressed	Battery voltage
					When the clutch pedal is not depressed	0 V
				Ignition switch ON (A/T models)	When selector lever is in P or N position and the brake is depressed	Battery voltage
					When selector lever is in P or N position and the brake is not depressed	0 V
61 (SB)	Ground	Trunk request switch	Input	Trunk request switch	ON (Pressed)	0 V
					OFF (Not pressed)	 1.0 V JPMIA0016GB
64 (L)	Ground	Request switch buzzer	Output	Request switch buzzer	Sounding	0 V
					Not sounding	Battery voltage

BCM (BODY CONTROL MODULE)

< ECU DIAGNOSIS >

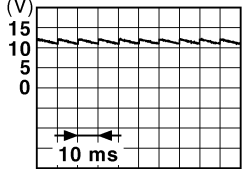
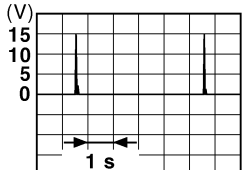
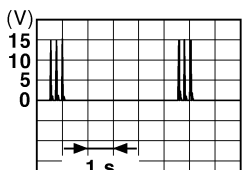
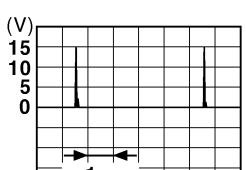
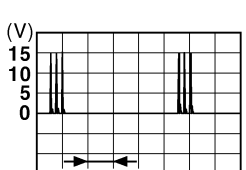
Terminal No. (Wire color)		Description		Condition	Value (Approx.)	
		Signal name	Input/ Output			
+	-					
67 (GR)	Ground	Trunk lid opener switch	Input	Trunk lid opener switch	Pressed	0 V
					Not pressed	 <p style="text-align: right; margin-right: 50px;">JPMIA0011GB</p> <p style="text-align: center;">11.8 V</p>
72 (R)	Ground	Room antenna 2 (-) (center console)	Output	Ignition switch OFF	When Intelligent Key is in the passenger compart- ment	 <p style="text-align: right; margin-right: 50px;">JMKIA0062GB</p>
					When Intelligent Key is not in the passenger compart- ment	 <p style="text-align: right; margin-right: 50px;">JMKIA0063GB</p>
73 (G)	Ground	Room antenna 2 (+) (center console)	Output	Ignition switch OFF	When Intelligent Key is in the passenger compart- ment	 <p style="text-align: right; margin-right: 50px;">JMKIA0062GB</p>
					When Intelligent Key is not in the passenger compart- ment	 <p style="text-align: right; margin-right: 50px;">JMKIA0063GB</p>

A
B
C
D
E
F
G
H
I
J
K
L
M
O
P

WCS

BCM (BODY CONTROL MODULE)

< ECU DIAGNOSIS >

Terminal No. (Wire color)		Description		Condition	Value (Approx.)
+	-	Signal name	Input/ Output		
74 (SB)	Ground	Passenger door antenna (-)	Output	When Intelligent Key is in the antenna detection area	<p style="text-align: right; font-size: small;">JMKIA0062GB</p>
				When Intelligent Key is not in the antenna detection area	<p style="text-align: right; font-size: small;">JMKIA0063GB</p>
75 (BR)	Ground	Passenger door antenna (+)	Output	When Intelligent Key is in the antenna detection area	<p style="text-align: right; font-size: small;">JMKIA0062GB</p>
				When Intelligent Key is not in the antenna detection area	<p style="text-align: right; font-size: small;">JMKIA0063GB</p>
76 (V)	Ground	Driver door antenna (-)	Output	When Intelligent Key is in the antenna detection area	<p style="text-align: right; font-size: small;">JMKIA0062GB</p>
				When Intelligent Key is not in the antenna detection area	<p style="text-align: right; font-size: small;">JMKIA0063GB</p>

BCM (BODY CONTROL MODULE)

< ECU DIAGNOSIS >





Terminal No. (Wire color)		Description		Condition	Value (Approx.)
		Signal name	Input/ Output		
+	-				
77 (LG)	Ground	Driver door antenna (+)	Output	When the driver door request switch is operated with ignition switch OFF	<p style="text-align: right; font-size: small;">JMKIA0062GB</p>
				When Intelligent Key is not in the antenna detection area	<p style="text-align: right; font-size: small;">JMKIA0063GB</p>
78 (Y)	Ground	Room antenna (-) (instrument panel)	Output	Ignition switch OFF	<p style="text-align: right; font-size: small;">JMKIA0062GB</p>
				When Intelligent Key is not in the passenger compartment	<p style="text-align: right; font-size: small;">JMKIA0063GB</p>
79 (BR)	Ground	Room antenna (+) (instrument panel)	Output	Ignition switch OFF	<p style="text-align: right; font-size: small;">JMKIA0062GB</p>
				When Intelligent Key is not in the passenger compartment	<p style="text-align: right; font-size: small;">JMKIA0063GB</p>

A
B
C
D
E
F
G
H
I
J
K
L
M
O
P

WCS

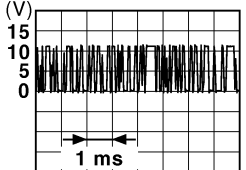
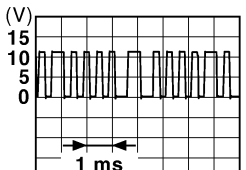

BCM (BODY CONTROL MODULE)

< ECU DIAGNOSIS >

Terminal No. (Wire color)		Description		Condition		Value (Approx.)
		Signal name	Input/ Output			
+	-					
80 (GR)	Ground	NATS antenna amp (built in key slot)	Input/ Output	During waiting	Ignition switch is pressed while inserting the Intelli- gent Key into the key slot.	Just after pressing ignition switch. Pointer of tester should move.
81 (W)	Ground	NATS antenna amp (built in key slot)	Input/ Output	During waiting	Ignition switch is pressed while inserting the Intelli- gent Key into the key slot.	Just after pressing ignition switch. Pointer of tester should move.
82 (R)	Ground	Ignition relay [fuse block (J/B)] control	Output	Ignition switch	OFF or ACC	0 V
						ON
83 (Y)	Ground	Remote keyless entry receiver signal	Input/ Output	During waiting		 <p style="text-align: right; font-size: small;">JMKIA0064GB</p>
				When operating either button on Intelligent Key		 <p style="text-align: right; font-size: small;">JMKIA0065GB</p>
87 (BR)	Ground	Combination switch INPUT 5	Input	Combination switch	All switch OFF (Wiper intermittent dial 4)	 <p style="text-align: right; font-size: small;">JPMIA0041GB</p> <p style="text-align: center;">1.4 V</p>
					Front fog lamp switch ON (Wiper intermittent dial 4)	 <p style="text-align: right; font-size: small;">JPMIA0037GB</p> <p style="text-align: center;">1.3 V</p>
					Any of the conditions below with all switch OFF	 <p style="text-align: right; font-size: small;">JPMIA0040GB</p> <p style="text-align: center;">1.3 V</p>

BCM (BODY CONTROL MODULE)

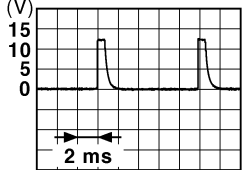
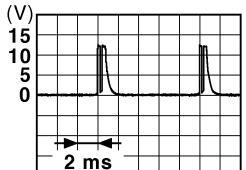
< ECU DIAGNOSIS >

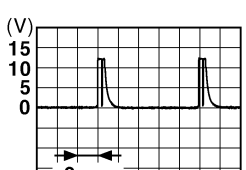
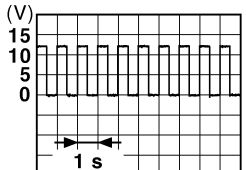
Terminal No. (Wire color)		Description		Condition	Value (Approx.)	
		Signal name	Input/ Output			
+	-					
88 (O)	Ground	Combination switch INPUT 3	Input	Combination switch	All switch OFF (Wiper intermittent dial 4)	 <small>JPMIA0041GB</small> 1.4 V
					Lighting switch HI (Wiper intermittent dial 4)	 <small>JPMIA0036GB</small> 1.3 V
					Lighting switch 2ND (Wiper intermittent dial 4)	 <small>JPMIA0037GB</small> 1.3 V
					Any of the conditions below with all switch OFF <ul style="list-style-type: none"> • Wiper intermittent dial 1 • Wiper intermittent dial 2 • Wiper intermittent dial 3 	 <small>JPMIA0040GB</small> 1.3 V
89 (BR)	Ground	Push-button ignition switch (push switch)	Input	Push-button igni- tion switch (push switch)	Pressed Not pressed 0 V Battery voltage	
90 (P)	Ground	CAN - L	Input/ Output	—	—	
91 (L)	Ground	CAN - H	Input/ Output	—	—	
92 (LG)	Ground	Key slot illumination	Output	Key slot illumina- tion	OFF	0 V
					Blinking	 <small>JPMIA0015GB</small> 6.5 V
					ON	Battery voltage

A
B
C
D
E
F
G
H
I
J
K
L
M

WCS

O
P



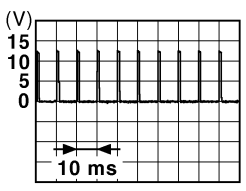
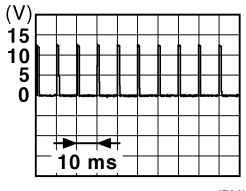

BCM (BODY CONTROL MODULE)

< ECU DIAGNOSIS >

Terminal No. (Wire color)		Description		Condition		Value (Approx.)
		Signal name	Input/ Output			
+	-					
93 (V)	Ground	ON indicator lamp	Output	Ignition switch	OFF or ACC	0 V
					ON	Battery voltage
95 (O)	Ground	ACC relay control	Output	Ignition switch	OFF	0 V
					ACC or ON	Battery voltage
96 (Y)	Ground	A/T device (detention switch) power supply	Output	—		Battery voltage
97 (L)	Ground	Steering lock condition No. 1	Input	Steering lock	LOCK status	0 V
					UNLOCK status	Battery voltage
98 (P)	Ground	Steering lock condition No. 2	Input	Steering lock	LOCK status	Battery voltage
					UNLOCK status	0 V
99 (R)	Ground	Selector lever P position switch (Except M/T models)	Input	Selector lever	P position	0 V
					Any position other than P	Battery voltage
		ASCD clutch switch (M/T models with ICC)		ASCD clutch switch	OFF (Clutch pedal is depressed)	0 V
					ON (Clutch pedal is not depressed)	Battery voltage
		ICC clutch switch (M/T models without ICC)		ICC clutch switch	OFF (Clutch pedal is depressed)	0 V
					ON (Clutch pedal is not depressed)	Battery voltage
100 (Y)	Ground	Passenger door request switch	Input	Passenger door request switch	ON (Pressed)	0 V
					OFF (Not pressed)	 <p style="text-align: right; font-size: small;">JPMIA0016GB</p> <p style="text-align: center;">1.0 V</p>
101 (P)	Ground	Driver door request switch	Input	Driver door request switch	ON (Pressed)	0 V
					OFF (Not pressed)	 <p style="text-align: right; font-size: small;">JPMIA0016GB</p> <p style="text-align: center;">1.0 V</p>
102 (O)	Ground	Blower fan motor relay control	Output	Ignition switch	OFF or ACC	0 V
					ON	Battery voltage
103 (LG)	Ground	Remote keyless entry receiver power supply	Output	Ignition switch OFF		Battery voltage
106 (W)	Ground	Steering wheel lock unit power supply	Output	Ignition switch	OFF or ACC	Battery voltage
					ON	0 V

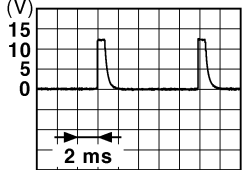
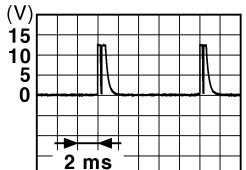
BCM (BODY CONTROL MODULE)

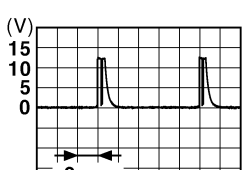
< ECU DIAGNOSIS >

Terminal No. (Wire color)		Description		Condition	Value (Approx.)	
		Signal name	Input/ Output			
+	-					
107 (LG)	Ground	Combination switch INPUT 1	Input	Combination switch (Wiper intermittent dial 4)	All switch OFF	 <p style="text-align: right;">1.4 V</p>
					Turn signal switch LH	 <p style="text-align: right;">1.3 V</p>
					Turn signal switch RH	 <p style="text-align: right;">1.3 V</p>
					Front wiper switch LO	 <p style="text-align: right;">1.3 V</p>
					Front washer switch ON	 <p style="text-align: right;">1.3 V</p>

A
B
C
D
E
F
G
H
I
J
K
L
M
O
P

WCS



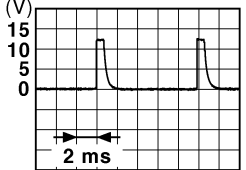
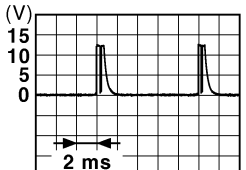
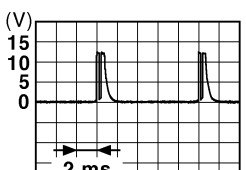
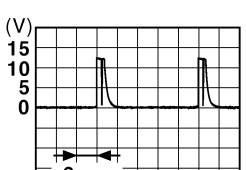

BCM (BODY CONTROL MODULE)

< ECU DIAGNOSIS >

Terminal No. (Wire color)		Description		Condition	Value (Approx.)	
		Signal name	Input/ Output			
+	-					
108 (R)	Ground	Combination switch INPUT 4	Input	Combination switch	All switch OFF (Wiper intermittent dial 4)	 <p style="text-align: right; font-size: small;">JPMIA0041GB</p> <p style="text-align: center;">1.4 V</p>
					Lighting switch AUTO (Wiper intermittent dial 4)	 <p style="text-align: right; font-size: small;">JPMIA0038GB</p> <p style="text-align: center;">1.3 V</p>
					Lighting switch 1ST (Wiper intermittent dial 4)	 <p style="text-align: right; font-size: small;">JPMIA0036GB</p> <p style="text-align: center;">1.3 V</p>
					Any of the conditions below with all switch OFF <ul style="list-style-type: none"> • Wiper intermittent dial 1 • Wiper intermittent dial 5 • Wiper intermittent dial 6 	 <p style="text-align: right; font-size: small;">JPMIA0039GB</p> <p style="text-align: center;">1.3 V</p>

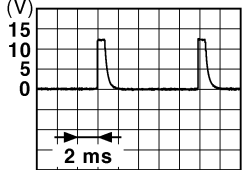
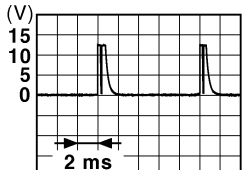
BCM (BODY CONTROL MODULE)

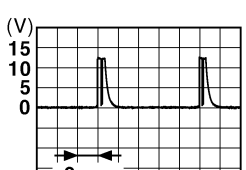
< ECU DIAGNOSIS >

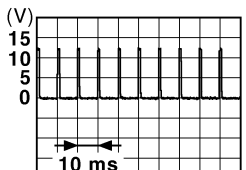
Terminal No. (Wire color)		Description		Condition	Value (Approx.)	
		Signal name	Input/ Output			
+	-					
109 (W)	Ground	Combination switch INPUT 2	Input	Combination switch (Wiper intermittent dial 4)	All switch OFF	 1.4 V
					Lighting switch PASS	 1.3 V
					Lighting switch 2ND	 1.3 V
					Front wiper switch INT	 1.3 V
					Front wiper switch HI	 1.3 V
					Pressed	0 V
110 (G)	Ground	Hazard switch	Input	Hazard switch	Not pressed	 1.1 V

A
B
C
D
E
F
G
H
I
J
K
L
M
O
P

WCS

BCM (BODY CONTROL MODULE)

< ECU DIAGNOSIS >

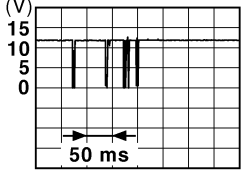
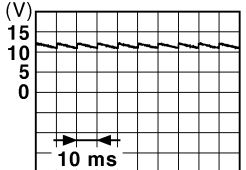
Terminal No. (Wire color)		Description		Condition	Value (Approx.)	
+	-	Signal name	Input/ Output			
111 (Y)	Ground	Steering lock unit communication	Input/ Output	Steering lock	LOCK status	Battery voltage
					LOCK or UNLOCK	 <p style="text-align: right; font-size: small;">JMkia0066GB</p>
					For 15 seconds after UN- LOCK	Battery voltage
					15 seconds or later after UNLOCK	0 V
113 (P)	Ground	Optical sensor signal	Input	Ignition switch ON	When bright outside of the vehicle	Close to 5 V
				When dark outside of the vehicle	Close to 0 V	
114 (R)	Ground	Clutch interlock switch	Input	Clutch interlock switch	OFF (Clutch pedal is not depressed)	0 V
					ON (Clutch pedal is de- pressed)	Battery voltage
116 (SB)	Ground	Stop lamp switch 1	Input	—	Battery voltage	
118 (BR)	Ground	Stop lamp switch 2	Input	Stop lamp switch	OFF (Brake pedal is not depressed)	0 V
					ON (Brake pedal is de- pressed)	Battery voltage
				ICC brake hold relay (With ICC)	OFF	0 V
					ON	Battery voltage
119 (SB)	Ground	Front door lock as- sembly driver side (unlock sensor)	Input	Driver door	LOCK status	 <p style="text-align: right; font-size: small;">JPMIA0011GB</p> <p style="text-align: center;">11.8 V</p>
					UNLOCK status	0 V
					When Intelligent Key is inserted into key slot	Battery voltage
121 (SB)	Ground	Key slot switch	Input	When Intelligent Key is not inserted into key slot	0 V	
				When Intelligent Key is inserted into key slot	Battery voltage	
122 (P)	Ground	ACC feedback signal	Input	Ignition switch	OFF	0 V
					ACC or ON	Battery voltage
123 (W)	Ground	IGN feedback signal	Input	Ignition switch	OFF or ACC	0 V
					ON	Battery voltage

BCM (BODY CONTROL MODULE)

< ECU DIAGNOSIS >

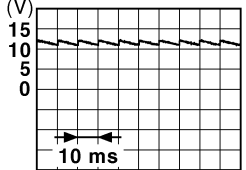
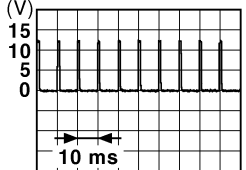
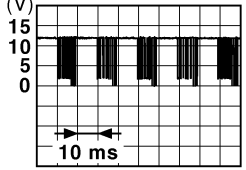
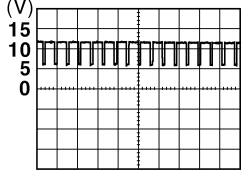
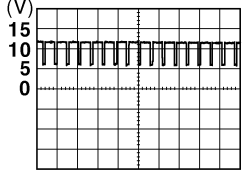

Terminal No. (Wire color)		Description		Condition	Value (Approx.)	
		Signal name	Input/ Output			
+	-					
124 (LG)	Ground	Passenger door switch	Input	Passenger door switch	 <p style="text-align: right; font-size: small;">JPMIA0011GB</p> <p style="text-align: center;">11.8 V</p>	
				OFF (When passenger door closes)	0 V	
129 (O)	Ground	Trunk lid opener cancel switch	Input	Trunk lid opener cancel switch	 <p style="text-align: right; font-size: small;">JPMIA0012GB</p> <p style="text-align: center;">1.1 V</p>	
				CANCEL	0 V	
132 (V)	Ground	Power window switch communication	Input/ Output	Ignition switch ON	 <p style="text-align: right; font-size: small;">JPMIA0013GB</p> <p style="text-align: center;">10.2 V</p>	
				Ignition switch OFF or ACC	0 V	
133 (L)	Ground	Push-button ignition switch illumination	Output	Push-button ignition switch illumination	<p>NOTE: The pulse width of this wave is varied by the illumination brightening/dimming level.</p>  <p style="text-align: right; font-size: small;">JPMIA0159GB</p>	
				ON (When tail lamps OFF)	5.5 V	
				ON (When tail lamps ON)	<p>NOTE: The pulse width of this wave is varied by the illumination brightening/dimming level.</p>  <p style="text-align: right; font-size: small;">JPMIA0159GB</p>	
OFF	0 V					
134 (LG)	Ground	LOCK indicator lamp	Output	LOCK indicator lamp	ON	0 V
				OFF	Battery voltage	
137 (O)	Ground	Receiver and sensor ground	Input	Ignition switch ON	0 V	
138 (V)	Ground	Receiver and sensor power supply output	Output	Ignition switch	OFF	0 V
				ACC or ON	5.0 V	

A
B
C
D
E
F
G
H
I
J
K
L
M
O
P

WCS

BCM (BODY CONTROL MODULE)

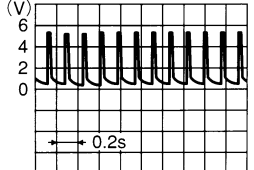
< ECU DIAGNOSIS >

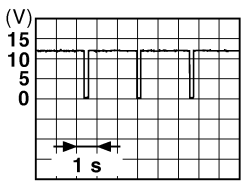
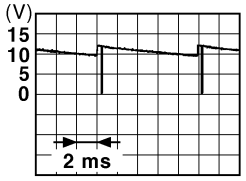
Terminal No. (Wire color)		Description		Condition	Value (Approx.)
+	-	Signal name	Input/ Output		
139 (L)	Ground	Tire pressure receiver signal	Input/ Output	Ignition switch ON	Standby state  OCC3881D
				When receiving the signal from the transmitter  OCC3880D	
140 (GR)	Ground	Selector lever P/N position signal	Input	Selector lever	P or N position 12.0 V Except P and N positions 0 V
				141 (R)	Ground
Blinking  11.3 V JPMIA0014GB					
142 (BR)	Ground	Combination switch OUTPUT 5	Output	Combination switch (Wiper intermittent dial 4)	All switch OFF 0 V
				143 (V)	Ground
All switch OFF (Wiper intermittent dial 4) Front wiper switch HI (Wiper intermittent dial 4) Any of the conditions below with all switch OFF • Wiper intermittent dial 1 • Wiper intermittent dial 2 • Wiper intermittent dial 3 • Wiper intermittent dial 6 • Wiper intermittent dial 7  10.7 V JPMIA0032GB					

BCM (BODY CONTROL MODULE)

< ECU DIAGNOSIS >

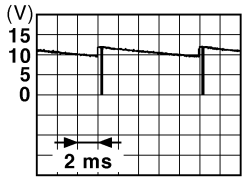
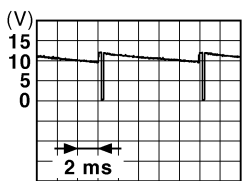
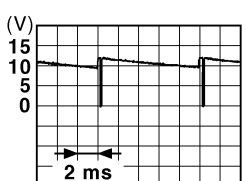
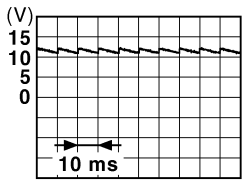
Terminal No. (Wire color)		Description		Condition	Value (Approx.)		
+	-	Signal name	Input/ Output				
144 (G)	Ground	Combination switch OUTPUT 2	Output	Combination switch	All switch OFF (Wiper intermittent dial 4)	0 V	
					Front washer switch ON (Wiper intermittent dial 4)		
					Any of the conditions below with all switch OFF		
					<ul style="list-style-type: none"> • Wiper intermittent dial 1 • Wiper intermittent dial 5 • Wiper intermittent dial 6 		
					10.7 V		
145 (L)	Ground	Combination switch OUTPUT 3	Output	Combination switch (Wiper intermit- tent dial 4)	All switch OFF	0 V	
					Front wiper switch INT		
					Front wiper switch LO		
					Lighting switch AUTO		
					10.7 V		
146 (SB)	Ground	Combination switch OUTPUT 4	Output	Combination switch (Wiper intermit- tent dial 4)	All switch OFF	0 V	
					Front fog lamp switch ON		
					Lighting switch 2ND		
					Lighting switch PASS		
					10.7 V		
149 (W)	Ground	Tire pressure warn- ing check switch	Input	—	5 V		
150 (R)	Ground	Driver door switch	Input	Driver door switch	OFF (When driver door closes)		
					ON (When driver door opens)		0 V
151 (G)	Ground	Rear window defog- ger relay	Output	Rear window de- fogger	Active	0 V	
					Not activated	Battery voltage	

A
B
C
D
E
F
G
H
I
J
K
L
M
O
P

WCS

BCM (BODY CONTROL MODULE)

< ECU DIAGNOSIS >

Wiring Diagram - BCM -

INFOID:000000001889424

Click here to view the eWD.

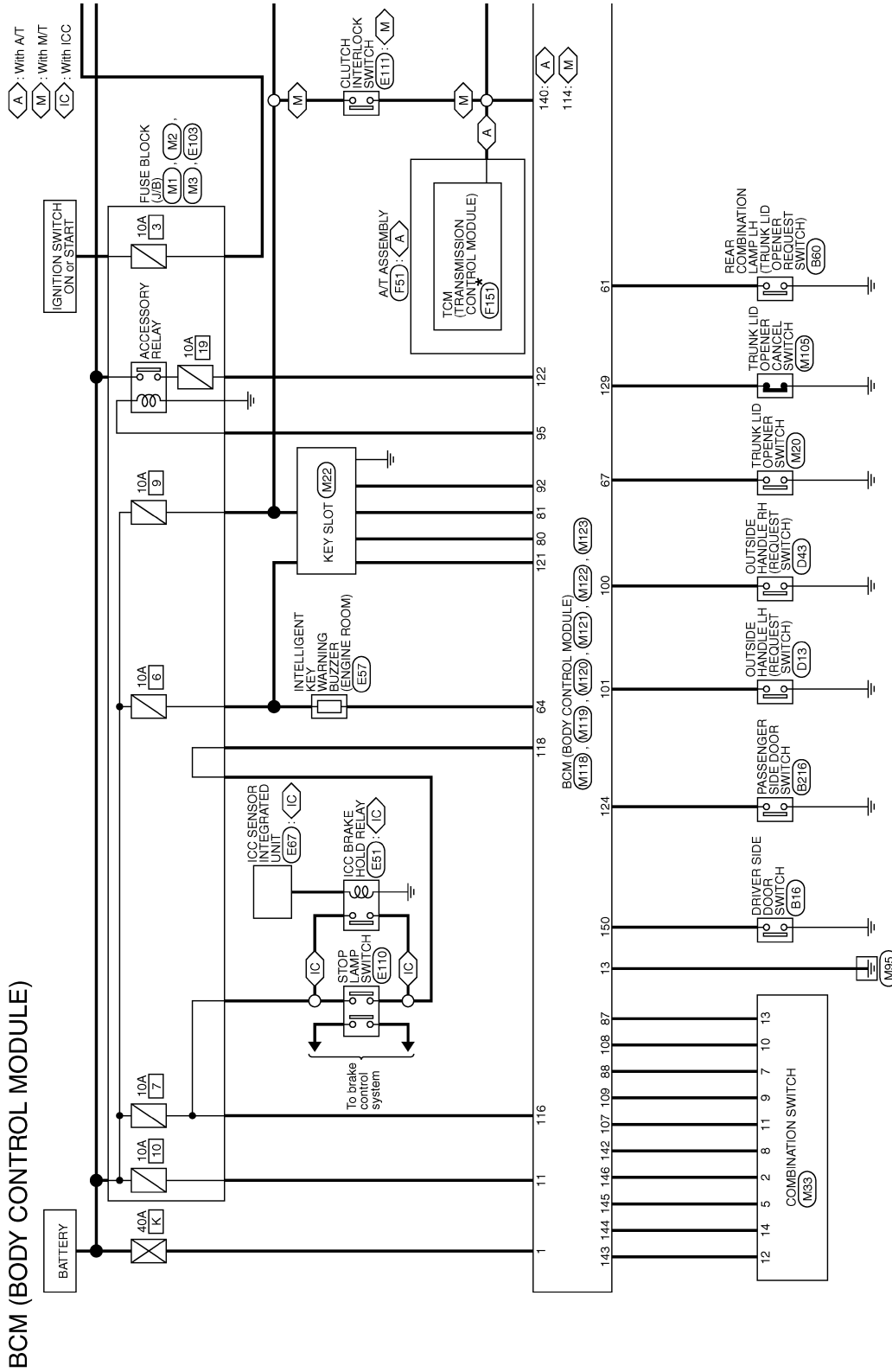

*: This connector is not shown in "Harness Layout".

2007/05/18

JCMWA0834GI

BCM (BODY CONTROL MODULE)

< ECU DIAGNOSIS >

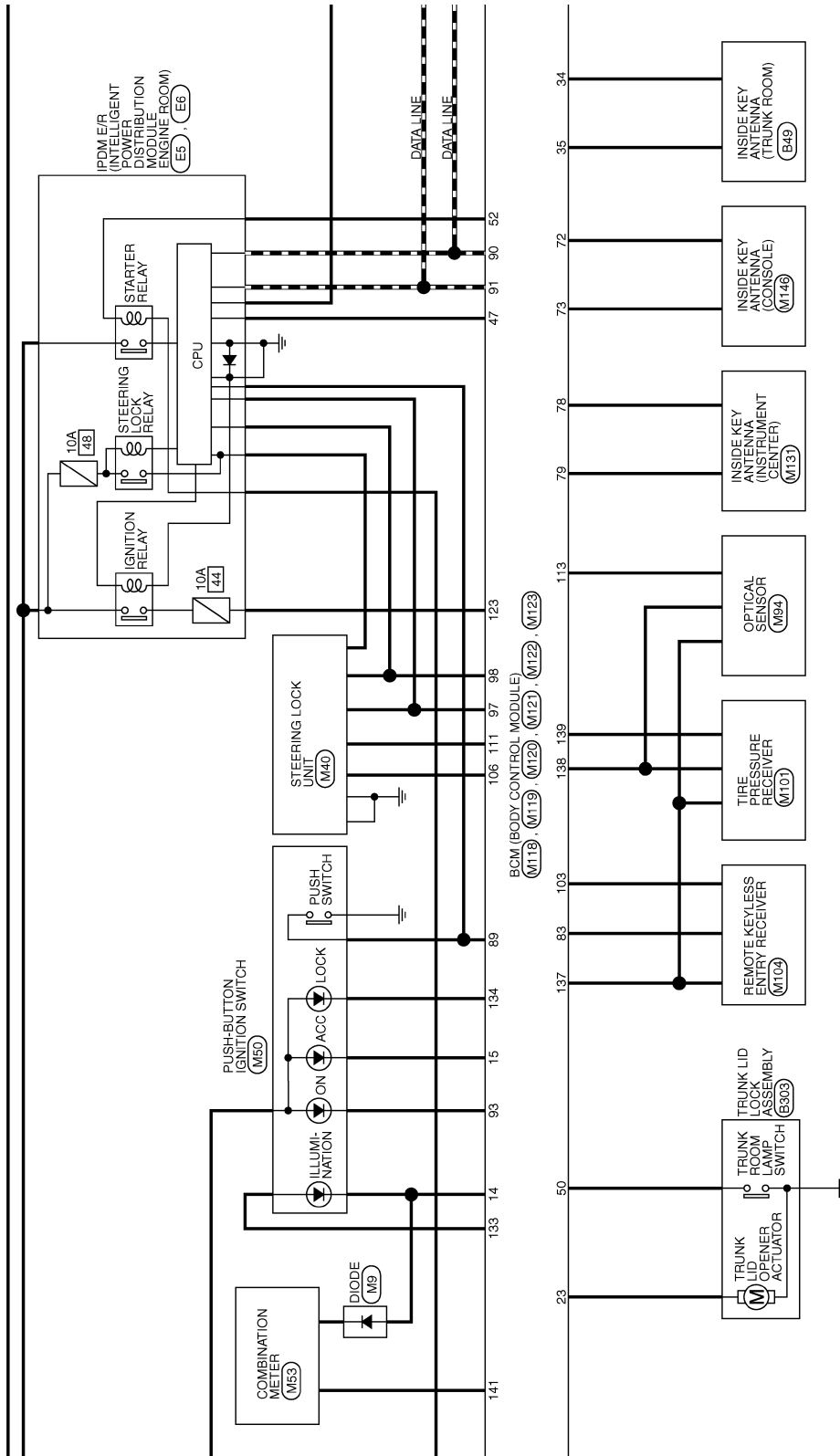

JCMWA0835GE

A
B
C
D
E
F
G
H
I
J
K
L
M
N
O
P

WCS

BCM (BODY CONTROL MODULE)

< ECU DIAGNOSIS >

- A : With A/T
- M : With M/T
- NV : With NAVI
- ON : Without NAVI
- RF : With sunroof
- IC : With ICC
- OI : Without ICC

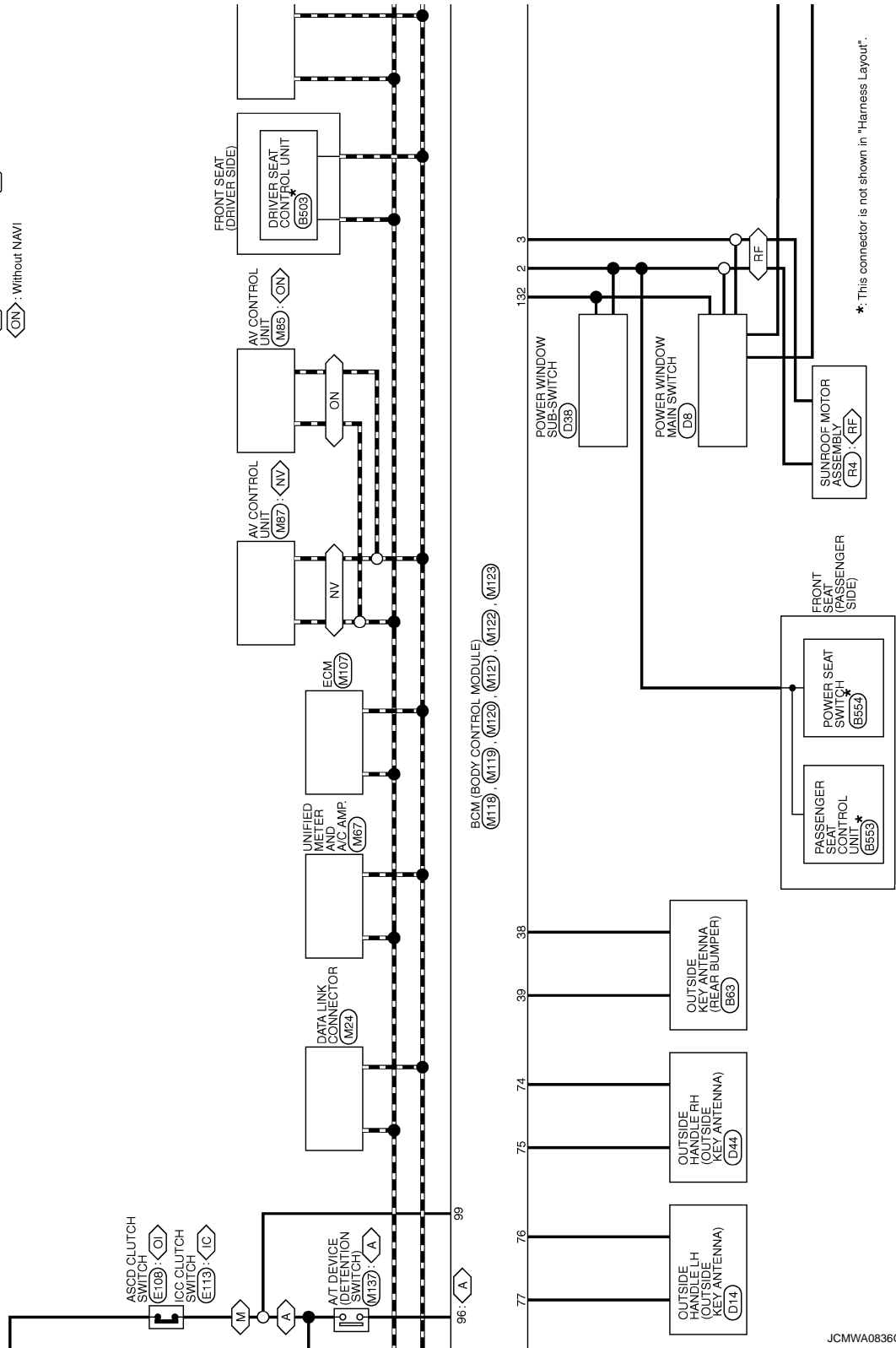

JCMWA0836G1

BCM (BODY CONTROL MODULE)

< ECU DIAGNOSIS >

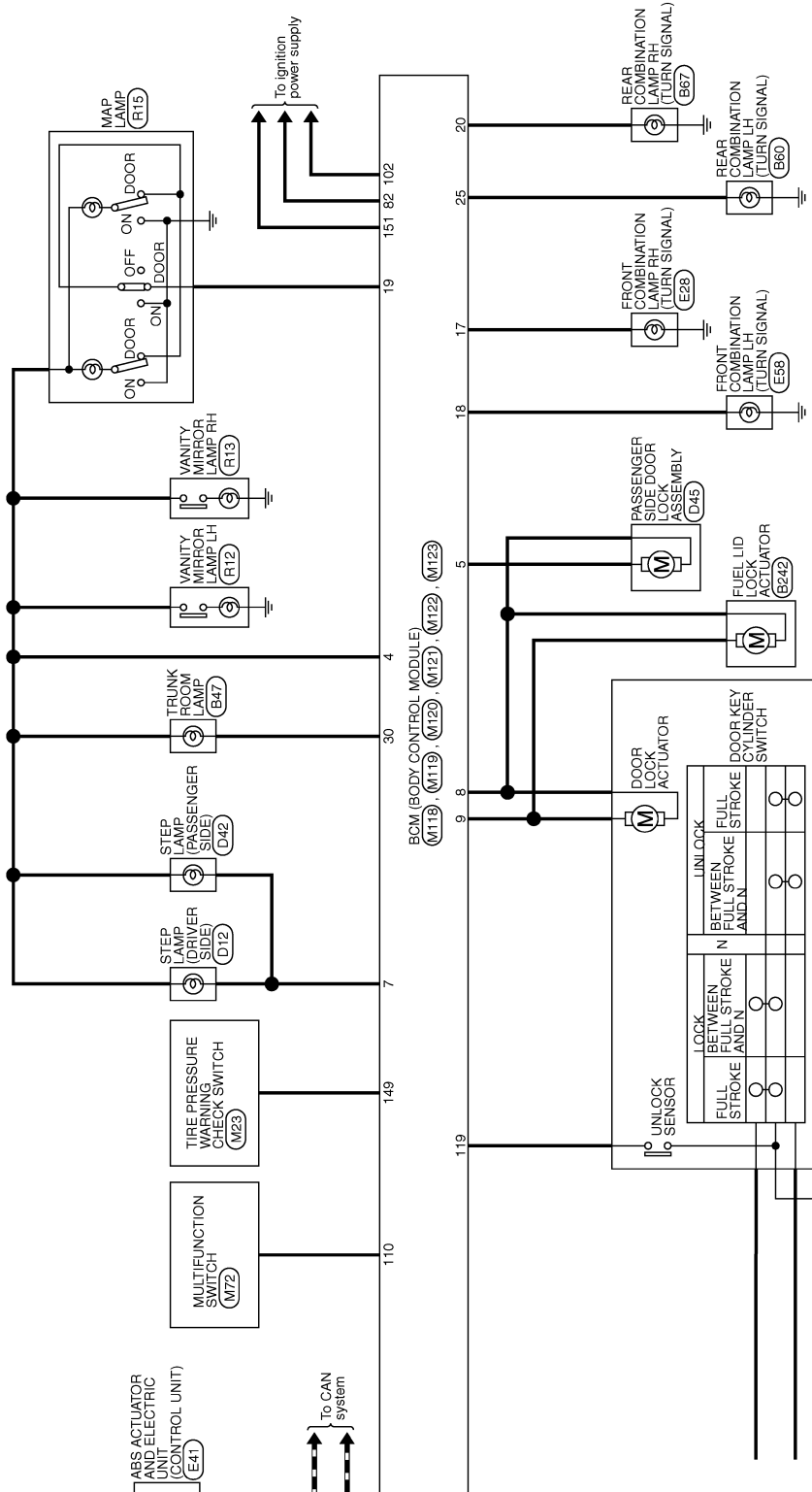

A
B
C
D
E
F
G
H
I
J
K
L
M
O
P

WCS

BCM (BODY CONTROL MODULE)

< ECU DIAGNOSIS >

BCM (BODY CONTROL MODULE)

Connector No.	M33
Connector Name	COMBINATION SWITCH
Connector Type	TH16FW-NH

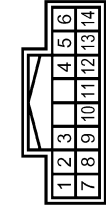

Terminal No.	Color of Wire	Signal Name [Specification]
2	SB	OUTPUT 4
5	L	OUTPUT 3
7	O	INPUT 3
8	BR	OUTPUT 5
9	W	INPUT 2
10	R	INPUT 4
11	LG	INPUT 1
12	V	OUTPUT 1
13	Y	INPUT 5
14	G	OUTPUT 2

BCM (BODY CONTROL MODULE)

Connector No.	M118
Connector Name	BCM (BODY CONTROL MODULE)
Connector Type	IM33FB-LC



Terminal No.	Color of Wire	Signal Name [Specification]
1	W	BAT (F/L)
2	Y	POWER WINDOW POWER SUPPLY (BAT)
3	O	POWER WINDOW POWER SUPPLY (RAP)

BCM (BODY CONTROL MODULE)

Connector No.	M119
Connector Name	BCM (BODY CONTROL MODULE)
Connector Type	NS16FW-CS

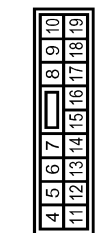

Terminal No.	Color of Wire	Signal Name [Specification]
4	LG	BAT SAVER OUTPUT
5	P	DOOR UNLOCK OUTPUT (AS)
7	SB	STEP LAMP OUTPUT
8	V	DOOR LOCK OUTPUT (ALL)
9	G	DOOR UNLOCK OUTPUT (DR)
11	R	BAT (FUSE)
13	B	GND
14	W	RING/SW LED GND
15	O	ACC LED
17	W	FRONT FLASHER OUTPUT (RIGHT)
18	O	FRONT FLASHER OUTPUT (LEFT)

19	V	ROOM LAMP OUTPUT
----	---	------------------

BCM (BODY CONTROL MODULE)

Connector No.	M120
Connector Name	BCM (BODY CONTROL MODULE)
Connector Type	NS12PW-CS



Terminal No.	Color of Wire	Signal Name [Specification]
20	V	REAR FLASHER OUTPUT (RIGHT)
23	L	TRUNK OPENER OUTPUT
25	Y	REAR FLASHER OUTPUT (LEFT)
30	P	TRUNK LAMP OUTPUT

BCM (BODY CONTROL MODULE)

Connector No.	M121
Connector Name	BCM (BODY CONTROL MODULE)
Connector Type	TH40GY-NH

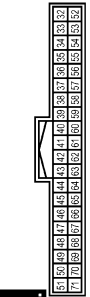

Terminal No.	Color of Wire	Signal Name [Specification]
34	SB	TRUNK ANTI-
35	V	TRUNK ANTI+
38	B	BACK ANTI-
39	W	BACK ANTI+
47	Y	RING USM CONT1
50	R	TRUNK SW
52	SB	ST CONT USM
61	SB	TRUNK REQUEST SW
64	L	BUTZRES
67	GR	INTERIOR TRUNK SW

BCM (BODY CONTROL MODULE)

Connector No.	M122
Connector Name	BCM (BODY CONTROL MODULE)
Connector Type	TH40FB-NH

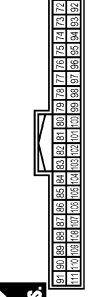

Terminal No.	Color of Wire	Signal Name [Specification]
72	R	ROOM ANTI-
73	G	ROOM ANTI+
74	SB	AS DOOR ANTI-
75	BR	AS DOOR ANTI+
76	V	DR DOOR ANTI-
77	LG	DR DOOR ANTI+
78	Y	ROOM ANTI-
79	BR	ROOM ANTI+
80	GR	IMMOBI ANTENNA CONTROL
81	W	IMMOBI ANTENNA SIGNAL
82	R	IGN ELEC CONT

83	Y	KEYLESS TUNER SIGNAL
87	Y	COMBI SW INPUT 5
88	O	COMBI SW INPUT 3
89	BR	ENG SW
90	P	CAN-L
91	L	CAN-H
92	LG	KEY SLOT ILL
93	Y	ON LED
95	O	ACC CONT
96	GR	A-T DEVICE
97	L	S/L CONDITION 1
98	P	S/L CONDITION 2
99	R	SHIFT P
100	Y	AS REQUEST SW
101	P	DR REQUEST SW
102	O	IGN2 CONT
103	LG	KEYLESS TUNER POWER SUPPLY
106	W	S/L 12V (CPU)
107	LG	COMBI SW INPUT 1
108	R	COMBI SW INPUT 4
109	W	COMBI SW INPUT 2
110	G	HAZARD SW
111	Y	S/L (K LINE)

BCM (BODY CONTROL MODULE)

< ECU DIAGNOSIS >

A
B
C
D
E
F
G
H
I
J
K
L
M
O
P

133	L	RING/SW LED
134	LG	LOCK LED
137	O	SENSOR GND
138	V	AUTO LIGHT SENSOR POWER SUPPLY
139	L	RECEIVER SIGNAL
140	GR	SHIFT INP
141	R	SECURITY INDICATOR OUTPUT
142	BR	COMET SW OUTPUT 5
143	V	COMET SW OUTPUT 1
144	G	COMET SW OUTPUT 2
145	L	COMET SW OUTPUT 3
146	SB	COMET SW OUTPUT 4
149	W	MODE TRG SW
150	R	DOOR SW (DR)
151	G	REAR DEFROGGER OUTPUT

BCM (BODY CONTROL MODULE)

Connector No.	M123
Connector Name	BCM (BODY CONTROL MODULE)
Connector Type	TH40FG-NH

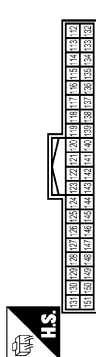

Terminal No.	Color of Wire	Signal Name [Specification]
113	O	AUTO LIGHT SENSOR INPUT
114	R	CLUTCH SW
116	SB	STOP LAMP LOW
118	BR	STOP LAMP HIGH
119	SB	DR CONDITION SW
121	SB	KEY SWITCH SIGNAL
122	P	ACC F/B
123	W	IGN F/B
124	LG	DOOR SW (AS)
129	O	TRUNK CANCEL SW
132	V	POWER WINDOW SERIAL LINK

JCMWA0839GE

INFOID:000000001889425

Fail Safe

Display contents of CONSULT	Fail-safe	Cancellation
B2013: ID DISCORD BCM-S/L	Inhibit engine cranking	Erase DTC
B2014: CHAIN OF S/L-BCM	Inhibit engine cranking	Erase DTC
B2190: NATS ANTENA AMP	Inhibit engine cranking	Erase DTC

WCS

BCM (BODY CONTROL MODULE)

< ECU DIAGNOSIS >

Display contents of CONSULT	Fail-safe	Cancellation
B2191: DIFFERENCE OF KEY	Inhibit engine cranking	Erase DTC
B2192: ID DISCORD BCM-ECM	Inhibit engine cranking	Erase DTC
B2193: CHAIN OF BCM-ECM	Inhibit engine cranking	Erase DTC
B2557: VEHICLE SPEED	Inhibit steering lock	When normal vehicle speed signals have been received from ABS actuator and electric unit (control unit) for 500 ms
B2560: STARTER CONT RELAY	Inhibit engine cranking	500 ms after the following CAN signal communication status has become consistent <ul style="list-style-type: none"> • Starter control relay signal • Starter relay status signal
B2563: HI VOLTAGE	<ul style="list-style-type: none"> • Inhibit engine cranking • Inhibit steering lock 	500 ms after the power supply voltage decreases to less than 18 V
B2601: SHIFT POSITION	Inhibit steering lock	500 ms after the following signal reception status becomes consistent <ul style="list-style-type: none"> • Selector lever P position switch signal • P range signal (CAN)
B2602: SHIFT POSITION	Inhibit steering lock	5 seconds after the following BCM recognition conditions are fulfilled <ul style="list-style-type: none"> • Ignition switch is in the ON position • Selector lever P position switch signal: Except P position (battery voltage) • Vehicle speed: 4 /h or more
B2603: SHIFT POSI STATUS	Inhibit steering lock	500 ms after the following BCM recognition conditions are fulfilled <ul style="list-style-type: none"> • Ignition switch is in the ON position • Selector lever P position switch signal: Except P position (battery voltage) • Selector lever P/N position signal: Except P and N positions (0 V)
B2604: PNP SW	Inhibit steering lock	500 ms after any of the following BCM recognition conditions is fulfilled <ul style="list-style-type: none"> • Status 1 <ul style="list-style-type: none"> - Ignition switch is in the ON position - Selector lever P/N position signal: P and N position (battery voltage) - P range signal or N range signal (CAN): ON • Status 2 <ul style="list-style-type: none"> - Ignition switch is in the ON position - Selector lever P/N position signal: Except P and N positions (0 V) - P range signal and N range signal (CAN): OFF
B2605: PNP SW	Inhibit steering lock	500 ms after any of the following BCM recognition conditions is fulfilled <ul style="list-style-type: none"> • Ignition switch is in the ON position <ul style="list-style-type: none"> - Power position: IGN - Selector lever P/N position signal: Except P and N positions (0 V) - Interlock/PNP switch signal (CAN): OFF • Status 2 <ul style="list-style-type: none"> - Ignition switch is in the ON position - Selector lever P/N position signal: P or N position (battery voltage) - PNP switch signal (CAN): ON
B2606: S/L RELAY	Inhibit engine cranking	500 ms after the following CAN signal communication status has become consistent <ul style="list-style-type: none"> • Steering lock relay signal (Request signal) • Steering lock relay signal (Condition signal)
B2607: S/L RELAY	Inhibit engine cranking	500 ms after the following CAN signal communication status has become consistent <ul style="list-style-type: none"> • Steering lock relay signal (Request signal) • Steering lock relay signal (Condition signal)

BCM (BODY CONTROL MODULE)

< ECU DIAGNOSIS >

Display contents of CONSULT	Fail-safe	Cancellation
B2608: STARTER RELAY	Inhibit engine cranking	500 ms after the following signal communication status becomes consistent <ul style="list-style-type: none"> • Starter motor relay control signal • Starter relay status signal (CAN)
B2609: S/L STATUS	<ul style="list-style-type: none"> • Inhibit engine cranking • Inhibit steering lock 	When the following steering lock conditions agree <ul style="list-style-type: none"> • BCM steering lock control status • Steering lock condition No. 1 signal status • Steering lock condition No. 2 signal status
B260A: IGNITION RELAY	Inhibit engine cranking	500 ms after the following conditions are fulfilled <ul style="list-style-type: none"> • IGN relay (IPDM E/R) control signal: OFF (Battery voltage) • Ignition ON signal (CAN to IPDM E/R): OFF (Request signal) • Ignition ON signal (CAN from IPDM E/R): OFF (Condition signal)
B260F: ENG STATE SIG LOST	Maintains the power supply position attained at the time of DTC detection	When any of the following conditions is fulfilled <ul style="list-style-type: none"> • Power position changes to ACC • Receives engine status signal (CAN)
B2612: S/L STATUS	<ul style="list-style-type: none"> • Inhibit engine cranking • Inhibit steering lock 	When any of the following conditions is fulfilled <ul style="list-style-type: none"> • Steering lock unit status signal (CAN) is received normally • The BCM steering lock control status matches the steering lock status recognized by the steering lock unit status signal (CAN from IPDM E/R)
B2617: STARTER RELAY CIRC	Inhibit engine cranking	1 second after the starter motor relay control inside BCM becomes normal
B2618: BCM	Inhibit engine cranking	1 second after the ignition relay (IPDM E/R) control inside BCM becomes normal
B2619: BCM	Inhibit engine cranking	1 second after the steering lock unit power supply output control inside BCM becomes normal
B261E: VEHICLE TYPE	Inhibit engine cranking	BCM initialization
B26E1: ENG STATE NO RECIV	Inhibit engine cranking	When any of the following conditions is fulfilled <ul style="list-style-type: none"> • Power position changes to ACC • Receives engine status signal (CAN)

DTC Inspection Priority Chart

INFOID:000000001889426

If some DTCs are displayed at the same time, perform inspections one by one based on the following priority chart.

Priority	DTC
1	<ul style="list-style-type: none"> • B2562: LOW VOLTAGE • B2563: HI VOLTAGE
2	<ul style="list-style-type: none"> • U1000: CAN COMM CIRCUIT • U1010: CONTROL UNIT (CAN)
3	<ul style="list-style-type: none"> • B2190: NATS ANTENA AMP • B2191: DIFFERENCE OF KEY • B2192: ID DISCORD BCM-ECM • B2193: CHAIN OF BCM-ECM

WCS

BCM (BODY CONTROL MODULE)

< ECU DIAGNOSIS >

Priority	DTC
4	<ul style="list-style-type: none"> • B2013: ID DISCORD BCM-S/L • B2014: CHAIN OF S/L-BCM • B2553: IGNITION RELAY • B2555: STOP LAMP • B2556: PUSH-BTN IGN SW • B2557: VEHICLE SPEED • B2560: STARTER CONT RELAY • B2601: SHIFT POSITION • B2602: SHIFT POSITION • B2603: SHIFT POSI STATUS • B2604: PNP SW • B2605: PNP SW • B2606: S/L RELAY • B2607: S/L RELAY • B2608: STARTER RELAY • B2609: S/L STATUS • B260A: IGNITION RELAY • B260B: STEERING LOCK UNIT • B260C: STEERING LOCK UNIT • B260D: STEERING LOCK UNIT • B260F: ENG STATE SIG LOST • B2611: ACC RELAY • B2612: S/L STATUS • B2614: ACC RELAY CIRC • B2615: BLOWER RELAY CIRC • B2616: IGN RELAY CIRC • B2617: STARTER RELAY CIRC • B2618: BCM • B2619: BCM • B261A: PUSH-BTN IGN SW • B261E: VEHICLE TYPE • B26E1: ENG STATE NO RECIV • C1729: VHCL SPEED SIG ERR • U0415: VEHICLE SPEED SIG
5	<ul style="list-style-type: none"> • C1704: LOW PRESSURE FL • C1705: LOW PRESSURE FR • C1706: LOW PRESSURE RR • C1707: LOW PRESSURE RL • C1708: [NO DATA] FL • C1709: [NO DATA] FR • C1710: [NO DATA] RR • C1711: [NO DATA] RL • C1712: [CHECKSUM ERR] FL • C1713: [CHECKSUM ERR] FR • C1714: [CHECKSUM ERR] RR • C1715: [CHECKSUM ERR] RL • C1716: [PRESSDATA ERR] FL • C1717: [PRESSDATA ERR] FR • C1718: [PRESSDATA ERR] RR • C1719: [PRESSDATA ERR] RL • C1720: [CODE ERR] FL • C1721: [CODE ERR] FR • C1722: [CODE ERR] RR • C1723: [CODE ERR] RL • C1724: [BATT VOLT LOW] FL • C1725: [BATT VOLT LOW] FR • C1726: [BATT VOLT LOW] RR • C1727: [BATT VOLT LOW] RL • C1734: CONTROL UNIT
6	<ul style="list-style-type: none"> • B2621: INSIDE ANTENNA • B2622: INSIDE ANTENNA • B2623: INSIDE ANTENNA

BCM (BODY CONTROL MODULE)

< ECU DIAGNOSIS >

DTC Index

INFOID:000000001889427

NOTE:

The details of time display are as follows.

- CRNT: A malfunction is detected now
- PAST: A malfunction was detected in the past.

IGN counter is displayed on Freeze Frame Data. The details of Freeze Frame Data and IGN Counter. Refer to [BCS-13, "COMMON ITEM : CONSULT-III Function \(BCM - COMMON ITEM\)"](#).

CONSULT display	Fail-safe	Freeze Frame Data	Intelligent Key warning lamp ON	Tire pressure monitor warning lamp ON	Reference page
No DTC is detected. further testing may be required.	—	—	—	—	—
U1000: CAN COMM CIRCUIT	—	—	—	—	BCS-33
U1010: CONTROL UNIT (CAN)	—	—	—	—	BCS-34
U0415: VEHICLE SPEED SIG	—	—	—	—	BCS-35
B2013: ID DISCORD BCM-S/L	×	×	—	—	SEC-54
B2014: CHAIN OF S/L-BCM	×	×	—	—	SEC-55
B2190: NATS ANTENA AMP	×	—	—	—	SEC-46
B2191: DIFFERENCE OF KEY	×	—	—	—	SEC-49
B2192: ID DISCORD BCM-ECM	×	—	—	—	SEC-50
B2193: CHAIN OF BCM-ECM	×	—	—	—	SEC-52
B2553: IGNITION RELAY	—	×	—	—	PCS-50
B2555: STOP LAMP	—	×	—	—	SEC-58
B2556: PUSH-BTN IGN SW	—	×	×	—	SEC-60
B2557: VEHICLE SPEED	×	×	×	—	SEC-62
B2560: STARTER CONT RELAY	×	×	×	—	SEC-63
B2562: LOW VOLTAGE	—	×	—	—	BCS-36
B2563: HI VOLTAGE	×	×	×	—	BCS-37
B2601: SHIFT POSITION	×	×	×	—	SEC-64
B2602: SHIFT POSITION	×	×	×	—	SEC-67
B2603: SHIFT POSI STATUS	×	×	×	—	SEC-69
B2604: PNP SW	×	×	×	—	SEC-72
B2605: PNP SW	×	×	×	—	SEC-74
B2606: S/L RELAY	×	×	×	—	SEC-76
B2607: S/L RELAY	×	×	×	—	SEC-77
B2608: STARTER RELAY	×	×	×	—	SEC-79
B2609: S/L STATUS	×	×	×	—	SEC-81
B260A: IGNITION RELAY	×	×	×	—	PCS-52
B260B: STEERING LOCK UNIT	—	×	×	—	SEC-85
B260C: STEERING LOCK UNIT	—	×	×	—	SEC-86
B260D: STEERING LOCK UNIT	—	×	×	—	SEC-87
B260F: ENG STATE SIG LOST	×	×	×	—	SEC-88
B2611: ACC RELAY	—	×	—	—	PCS-54
B2612: S/L STATUS	×	×	×	—	SEC-90
B2614: ACC RELAY CIRC	—	×	×	—	PCS-57
B2615: BLOWER RELAY CIRC	—	×	×	—	PCS-60

BCM (BODY CONTROL MODULE)

< ECU DIAGNOSIS >

CONSULT display	Fail-safe	Freeze Frame Data	Intelligent Key warning lamp ON	Tire pressure monitor warning lamp ON	Reference page
B2616: IGN RELAY CIRC	—	×	×	—	PCS-63
B2617: STARTER RELAY CIRC	×	×	×	—	SEC-94
B2618: BCM	×	×	×	—	PCS-66
B2619: BCM	×	×	×	—	SEC-96
B261A: PUSH-BTN IGN SW	—	×	×	—	SEC-97
B261E: VEHICLE TYPE	×	×	× (Turn ON for 15 seconds)	—	SEC-100
B2621: INSIDE ANTENNA	—	×	—	—	DLK-59
B2622: INSIDE ANTENNA	—	×	—	—	DLK-61
B2623: INSIDE ANTENNA	—	×	—	—	DLK-63
B26E1: ENG STATE NO RES	×	×	×	—	SEC-89
C1704: LOW PRESSURE FL	—	—	—	×	WT-15
C1705: LOW PRESSURE FR	—	—	—	×	WT-15
C1706: LOW PRESSURE RR	—	—	—	×	WT-15
C1707: LOW PRESSURE RL	—	—	—	×	WT-15
C1708: [NO DATA] FL	—	—	—	×	WT-17
C1709: [NO DATA] FR	—	—	—	×	WT-17
C1710: [NO DATA] RR	—	—	—	×	WT-17
C1711: [NO DATA] RL	—	—	—	×	WT-17
C1712: [CHECKSUM ERR] FL	—	—	—	×	WT-20
C1713: [CHECKSUM ERR] FR	—	—	—	×	WT-20
C1714: [CHECKSUM ERR] RR	—	—	—	×	WT-20
C1715: [CHECKSUM ERR] RL	—	—	—	×	WT-20
C1716: [PRESSDATA ERR] FL	—	—	—	×	WT-23
C1717: [PRESSDATA ERR] FR	—	—	—	×	WT-23
C1718: [PRESSDATA ERR] RR	—	—	—	×	WT-23
C1719: [PRESSDATA ERR] RL	—	—	—	×	WT-23
C1720: [CODE ERR] FL	—	—	—	×	WT-25
C1721: [CODE ERR] FR	—	—	—	×	WT-25
C1722: [CODE ERR] RR	—	—	—	×	WT-25
C1723: [CODE ERR] RL	—	—	—	×	WT-25
C1724: [BATT VOLT LOW] FL	—	—	—	×	WT-28
C1725: [BATT VOLT LOW] FR	—	—	—	×	WT-28
C1726: [BATT VOLT LOW] RR	—	—	—	×	WT-28
C1727: [BATT VOLT LOW] RL	—	—	—	×	WT-28
C1729: VHCL SPEED SIG ERR	—	—	—	×	WT-31
C1734: CONTROL UNIT	—	—	—	×	WT-32

THE PARKING BRAKE RELEASE WARNING CONTINUES SOUNDING, OR DOES NOT SOUND

< SYMPTOM DIAGNOSIS >

SYMPTOM DIAGNOSIS

THE PARKING BRAKE RELEASE WARNING CONTINUES SOUNDING, OR DOES NOT SOUND

Description

INFOID:000000001606848

- The parking brake warning chime sounds continuously during vehicle travel though the parking brake is released
- The parking brake warning chime does not sound at all even though driving the vehicle with the parking brake applied.

Diagnosis Procedure

INFOID:000000001606849

1. CHECK UNIFIED METER AND A/C AMP. INPUT SIGNAL

1. Connect the CONSULT-III.
2. Select the "Data Monitor" of the "METER/M&A" and check the "PKB SW" monitor value. Refer to [MWI-59, "Component Function Check"](#).

Is the inspection result normal?

- YES >> Replace combination meter.
- NO >> GO TO 2.

2. CHECK PARKING BRAKE SWITCH SIGNAL CIRCUIT

Check the parking brake switch signal circuit. Refer to [BRC-71, "Diagnosis Procedure"](#).

Is the inspection result normal?

- YES >> GO TO 3.
- NO >> Repair harness or connector.

3. CHECK PARKING BRAKE SWITCH

Check the parking brake switch. Refer to [BRC-72, "Component Inspection"](#).

Is the inspection result normal?

- YES >> Replace the combination meter.
- NO >> Replace the parking brake switch. Refer to [PB-7, "PEDAL TYPE : Removal and Installation"](#) (pedal type) or [PB-8, "LEVER TYPE : Removal and Installation"](#) (lever type).

A
B
C
D
E
F
G
H
I
J
K
L
M
O
P

WCS

THE LIGHT REMINDER WARNING DOES NOT SOUND

< SYMPTOM DIAGNOSIS >

THE LIGHT REMINDER WARNING DOES NOT SOUND

Description

INFOID:000000001606850

Light reminder warning chime does not sound even though headlamp is illuminated.

Diagnosis Procedure

INFOID:000000001606851

1. CHECK COMBINATION SWITCH (LIGHT SWITCH) OPERATION

Check that the headlamps operate normally by operating the combination switch (light switch).

Do they operate normally?

YES >> GO TO 2.

NO >> Refer to [EXL-178, "Diagnosis Procedure"](#).

2. CHECK FRONT DRIVER SIDE DOOR SWITCH SIGNAL CIRCUIT

Check the front driver side door switch signal circuit. Refer to [DLK-66, "Diagnosis Procedure"](#).

Is the inspection result normal?

YES >> GO TO 3.

NO >> Repair harness or connector.

3. CHECK FRONT DRIVER SIDE DOOR SWITCH

Check the front driver side door switch. Refer to [DLK-67, "Component Inspection"](#).

Is the inspection result normal?

YES >> Replace the BCM. Refer to [BCS-79, "Removal and Installation"](#).

NO >> Replace the front driver side door switch. Refer to [DLK-238, "Removal and Installation"](#).

THE SEAT BELT WARNING CONTINUES SOUNDING, OR DOES NOT SOUND

< SYMPTOM DIAGNOSIS >

THE SEAT BELT WARNING CONTINUES SOUNDING, OR DOES NOT SOUND

Description

INFOID:000000001606852

- Seat belt warning chime does not sound even though driver seat belt is unfastened.
- Seat belt warning chime sounds even though driver seat belt is fastened.

Diagnosis Procedure

INFOID:000000001606853

1. CHECK SEAT BELT WARNING LAMP

1. Turn ignition switch ON.
2. Check the operation of the seat belt warning lamp in the combination meter.

Seat belt fastened : OFF
Seat belt unfastened : ON

Is the inspection result normal?

- YES >> Replace the BCM.
NO >> GO TO 2.

2. CHECK UNIFIED METER AND A/C AMP. INPUT SIGNAL

1. Connect the CONSULT-III.
2. Select the "Data Monitor" of the "METER/M&A" and check the "BUCKLE SW" monitor value. Refer to [WCS-24, "Component Function Check"](#).

Is the inspection result normal?

- YES >> Replace the combination meter.
NO >> GO TO 3.

3. CHECK SEAT BELT BUCKLE SWITCH (DRIVER SIDE) SIGNAL CIRCUIT

Check the seat belt buckle switch (driver side) signal circuit. Refer to [WCS-24, "Diagnosis Procedure"](#).

Is the inspection result normal?

- YES >> GO TO 4.
NO >> Repair harness or connector.

4. CHECK SEAT BELT BUCKLE SWITCH (DRIVER SIDE)

Check the seat belt buckle switch (driver side). Refer to [WCS-25, "Component Inspection"](#).

Is the inspection result normal?

- YES >> Replace the unified meter and A/C amp.
NO >> Replace the seat belt buckle switch (driver side). Refer to [SB-7, "SEAT BELT BUCKLE : Removal and Installation"](#).

WCS

PRECAUTIONS

< PRECAUTION >

PRECAUTION

PRECAUTIONS

Precaution for Supplemental Restraint System (SRS) "AIR BAG" and "SEAT BELT PRE-TENSIONER"

INFOID:000000001696931

The Supplemental Restraint System such as "AIR BAG" and "SEAT BELT PRE-TENSIONER", used along with a front seat belt, helps to reduce the risk or severity of injury to the driver and front passenger for certain types of collision. This system includes seat belt switch inputs and dual stage front air bag modules. The SRS system uses the seat belt switches to determine the front air bag deployment, and may only deploy one front air bag, depending on the severity of a collision and whether the front occupants are belted or unbelted. Information necessary to service the system safely is included in the "SRS AIRBAG" and "SEAT BELT" of this Service Manual.

WARNING:

- **To avoid rendering the SRS inoperative, which could increase the risk of personal injury or death in the event of a collision which would result in air bag inflation, all maintenance must be performed by an authorized NISSAN/INFINITI dealer.**
- **Improper maintenance, including incorrect removal and installation of the SRS, can lead to personal injury caused by unintentional activation of the system. For removal of Spiral Cable and Air Bag Module, see the "SRS AIRBAG".**
- **Do not use electrical test equipment on any circuit related to the SRS unless instructed to in this Service Manual. SRS wiring harnesses can be identified by yellow and/or orange harnesses or harness connectors.**