

SECTION **PG**

**POWER SUPPLY, GROUND & CIRCUIT ELEMENTS**

**CONTENTS**

<b>PRECAUTIONS</b> .....	<b>3</b>	Terminals and Reference Values for IPDM E/R .....	28
Precautions for Supplemental Restraint System (SRS) "AIR BAG" and "SEAT BELT PRE-TENSIONER" .....	3	IPDM E/R Power/Ground Circuit Inspection .....	30
<b>POWER SUPPLY ROUTING CIRCUIT</b> .....	<b>4</b>	Inspection with CONSULT-II (Self-Diagnosis) .....	31
Schematic .....	4	Removal and Installation of IPDM E/R .....	32
Wiring Diagram — POWER — .....	6	REMOVAL .....	32
BATTERY POWER SUPPLY — IGNITION SW. IN ANY POSITION .....	6	INSTALLATION .....	32
ACCESSORY POWER SUPPLY — IGNITION SW. IN ACC OR ON .....	12	<b>GROUND CIRCUIT</b> .....	<b>33</b>
IGNITION POWER SUPPLY — IGNITION SW. IN ON .....	13	Ground Distribution .....	33
IGNITION POWER SUPPLY — IGNITION SW. IN ON AND/OR START .....	14	MAIN HARNESS .....	33
IGNITION POWER SUPPLY — IGNITION SWITCH IN START .....	16	ENGINE ROOM HARNESS .....	36
Fuse .....	17	ENGINE CONTROL HARNESS (VQ40DE MODELS) .....	40
Fusible Link .....	17	ENGINE CONTROL HARNESS (QR25DE MODELS) .....	41
Circuit Breaker (Built Into BCM) .....	17	BODY HARNESS .....	42
<b>IPDM E/R (INTELLIGENT POWER DISTRIBUTION MODULE ENGINE ROOM)</b> .....	<b>18</b>	BODY NO. 2 HARNESS .....	43
System Description .....	18	<b>HARNESS</b> .....	<b>44</b>
SYSTEMS CONTROLLED BY IPDM E/R .....	18	Harness Layout .....	44
CAN COMMUNICATION LINE CONTROL .....	18	HOW TO READ HARNESS LAYOUT .....	44
IPDM E/R STATUS CONTROL .....	19	OUTLINE (KING CAB MODELS) .....	45
CAN Communication System Description .....	19	OUTLINE (CREW CAB MODELS) .....	46
Function of Detecting Ignition Relay Malfunction ...	19	MAIN HARNESS .....	47
CONSULT-II Function (IPDM E/R) .....	20	ENGINE ROOM HARNESS (RH VIEW) .....	49
CONSULT-II START PROCEDURE .....	20	ENGINE ROOM HARNESS (LH VIEW) .....	53
SELF-DIAGNOSTIC RESULTS .....	20	ENGINE CONTROL HARNESS (QR25DE MODELS) .....	55
DATA MONITOR .....	21	ENGINE CONTROL HARNESS (VQ40DE MODELS) .....	57
CAN DIAG SUPPORT MNTR .....	21	CHASSIS HARNESS .....	59
ACTIVE TEST .....	21	BODY HARNESS (KING CAB MODELS) .....	61
Auto Active Test .....	23	BODY HARNESS (CREW CAB MODELS) .....	63
DESCRIPTION .....	23	BODY NO. 2 HARNESS (KING CAB MODELS)..	65
OPERATION PROCEDURE .....	23	BODY NO. 2 HARNESS (CREW CAB MODELS)..	67
INSPECTION IN AUTO ACTIVE TEST MODE... ..	23	ROOM LAMP HARNESS .....	69
Schematic .....	26	FRONT DOOR LH HARNESS .....	71
IPDM E/R Terminal Arrangement .....	27	FRONT DOOR RH HARNESS .....	72
		REAR DOOR LH HARNESS (KING CAB MODELS) .....	73
		REAR DOOR RH HARNESS (KING CAB MODELS) .....	74

A  
B  
C  
D  
E  
F  
G  
H  
I  
J  
L  
M

**PG**

REAR DOOR LH HARNESS (CREW CAB MOD-ELS) .....	75	SRS COMPONENT TYPE) .....	86
REAR DOOR RH HARNESS (CREW CAB MOD-ELS) .....	76	<b>ELECTRICAL UNITS</b> .....	<b>87</b>
Wiring Diagram Codes (Cell Codes) .....	77	Terminal Arrangement .....	87
<b>ELECTRICAL UNITS LOCATION</b> .....	<b>80</b>	<b>STANDARDIZED RELAY</b> .....	<b>88</b>
Electrical Units Location .....	80	Description .....	88
ENGINE COMPARTMENT .....	80	NORMAL OPEN, NORMAL CLOSED AND MIXED TYPE RELAYS .....	88
PASSENGER COMPARTMENT .....	81	TYPE OF STANDARDIZED RELAYS .....	88
<b>HARNESS CONNECTOR</b> .....	<b>83</b>	<b>SUPER MULTIPLE JUNCTION (SMJ)</b> .....	<b>90</b>
Description .....	83	Terminal Arrangement .....	90
HARNESS CONNECTOR (TAB-LOCKING TYPE) .....	83	<b>FUSE BLOCK-JUNCTION BOX (J/B)</b> .....	<b>92</b>
HARNESS CONNECTOR (SLIDE-LOCKING TYPE) .....	84	Terminal Arrangement .....	92
HARNESS CONNECTOR (LEVER LOCKING TYPE) .....	85	<b>FUSE AND FUSIBLE LINK BOX</b> .....	<b>93</b>
HARNESS CONNECTOR (DIRECT-CONNECT TYPE) .....	85	Terminal Arrangement .....	93
		<b>FUSE AND RELAY BOX</b> .....	<b>94</b>
		Terminal Arrangement .....	94

# PRECAUTIONS

## PRECAUTIONS

PFP:00011

### Precautions for Supplemental Restraint System (SRS) “AIR BAG” and “SEAT BELT PRE-TENSIONER”

EKS00E0D

The Supplemental Restraint System such as “AIR BAG” and “SEAT BELT PRE-TENSIONER”, used along with a front seat belt, helps to reduce the risk or severity of injury to the driver and front passenger for certain types of collision. This system includes seat belt switch inputs and dual stage front air bag modules. The SRS system uses the seat belt switches to determine the front air bag deployment, and may only deploy one front air bag, depending on the severity of a collision and whether the front occupants are belted or unbelted. Information necessary to service the system safely is included in the SRS and SB section of this Service Manual.

#### **WARNING:**

- To avoid rendering the SRS inoperative, which could increase the risk of personal injury or death in the event of a collision which would result in air bag inflation, all maintenance must be performed by an authorized NISSAN/INFINITI dealer.
- Improper maintenance, including incorrect removal and installation of the SRS, can lead to personal injury caused by unintentional activation of the system. For removal of Spiral Cable and Air Bag Module, see the SRS section.
- Do not use electrical test equipment on any circuit related to the SRS unless instructed to in this Service Manual. SRS wiring harnesses can be identified by yellow and/or orange harnesses or harness connectors.

A

B

C

D

E

F

G

H

I

J

PG

L

M

# POWER SUPPLY ROUTING CIRCUIT

PF:24110

## POWER SUPPLY ROUTING CIRCUIT

### Schematic

EKS00E0F

For detailed ground distribution, refer to [PG-33, "Ground Distribution"](#).

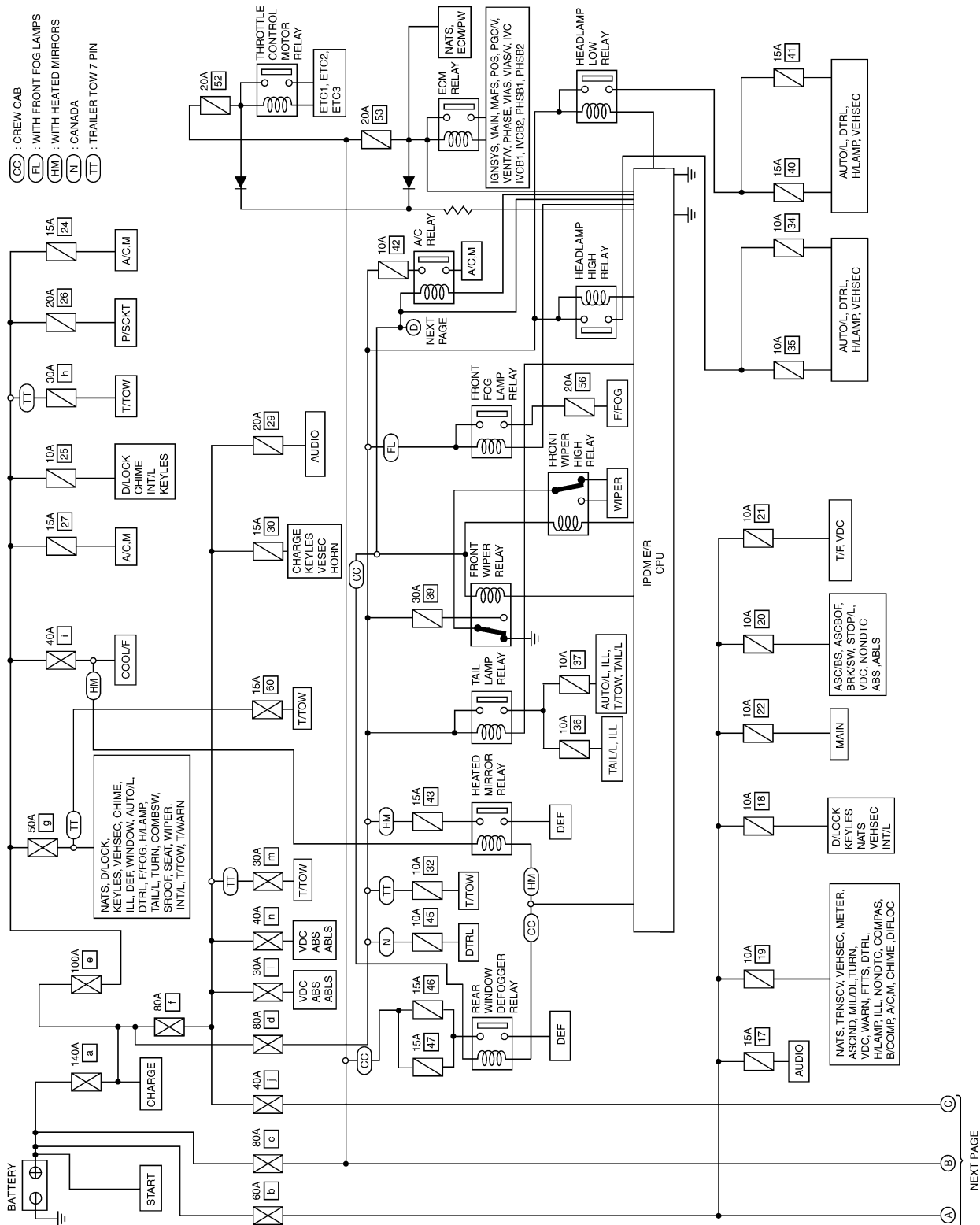

WKWA5498E

# POWER SUPPLY ROUTING CIRCUIT

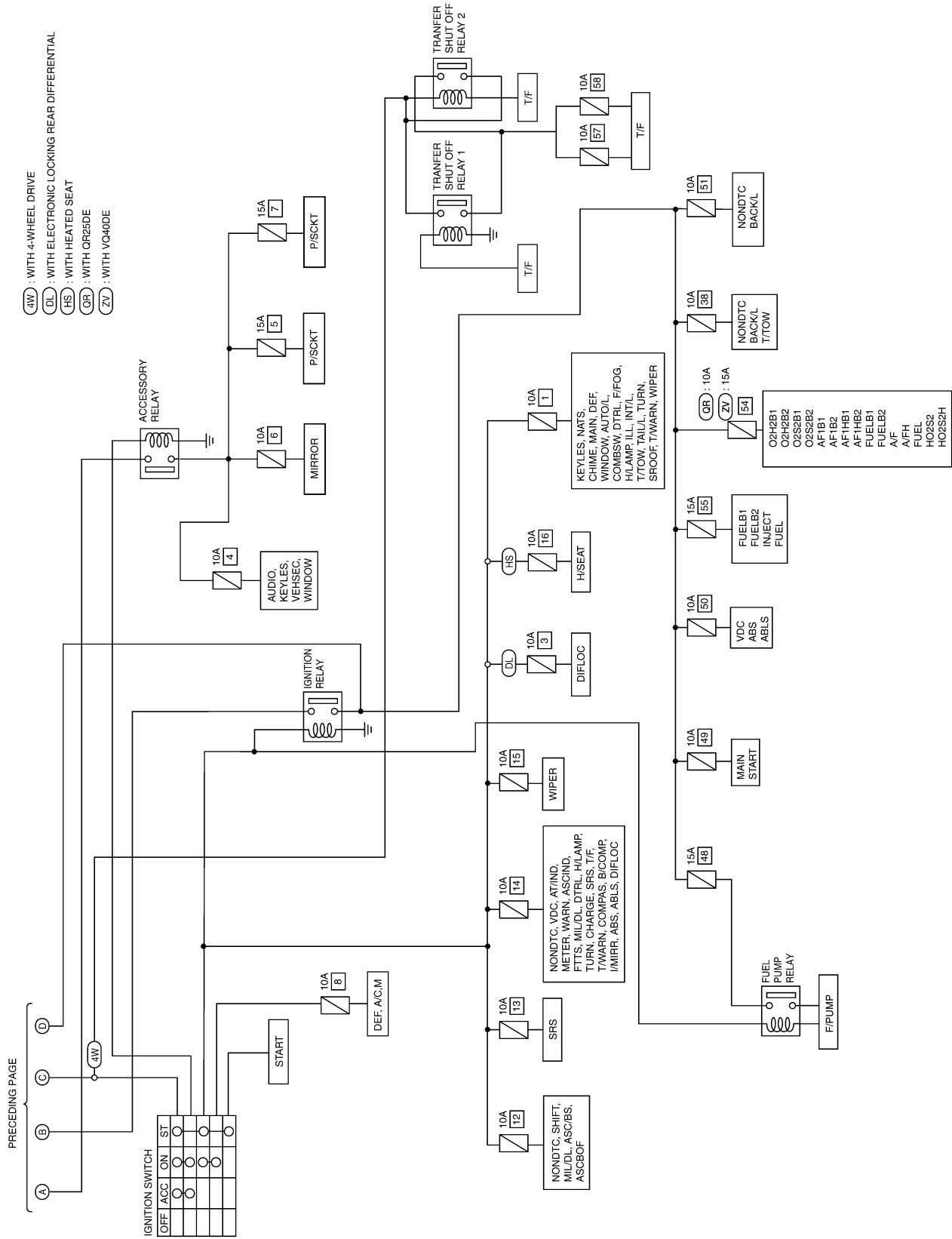

A  
B  
C  
D  
E  
F  
G  
H  
I  
J  
L  
M

PG

WKWA5499E

# POWER SUPPLY ROUTING CIRCUIT

## Wiring Diagram — POWER — BATTERY POWER SUPPLY — IGNITION SW. IN ANY POSITION

EKS00EOG

### PG-POWER-01

TT : TRAILER TOW 7 PIN  
4W : WITH 4-WHEEL DRIVE

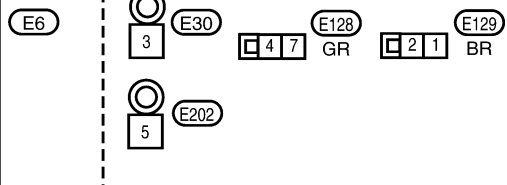
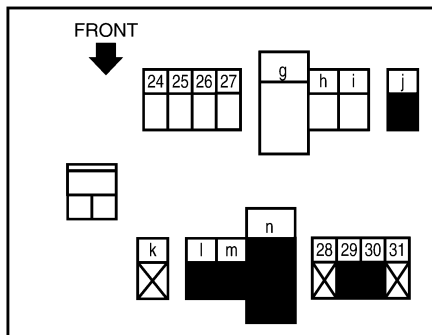
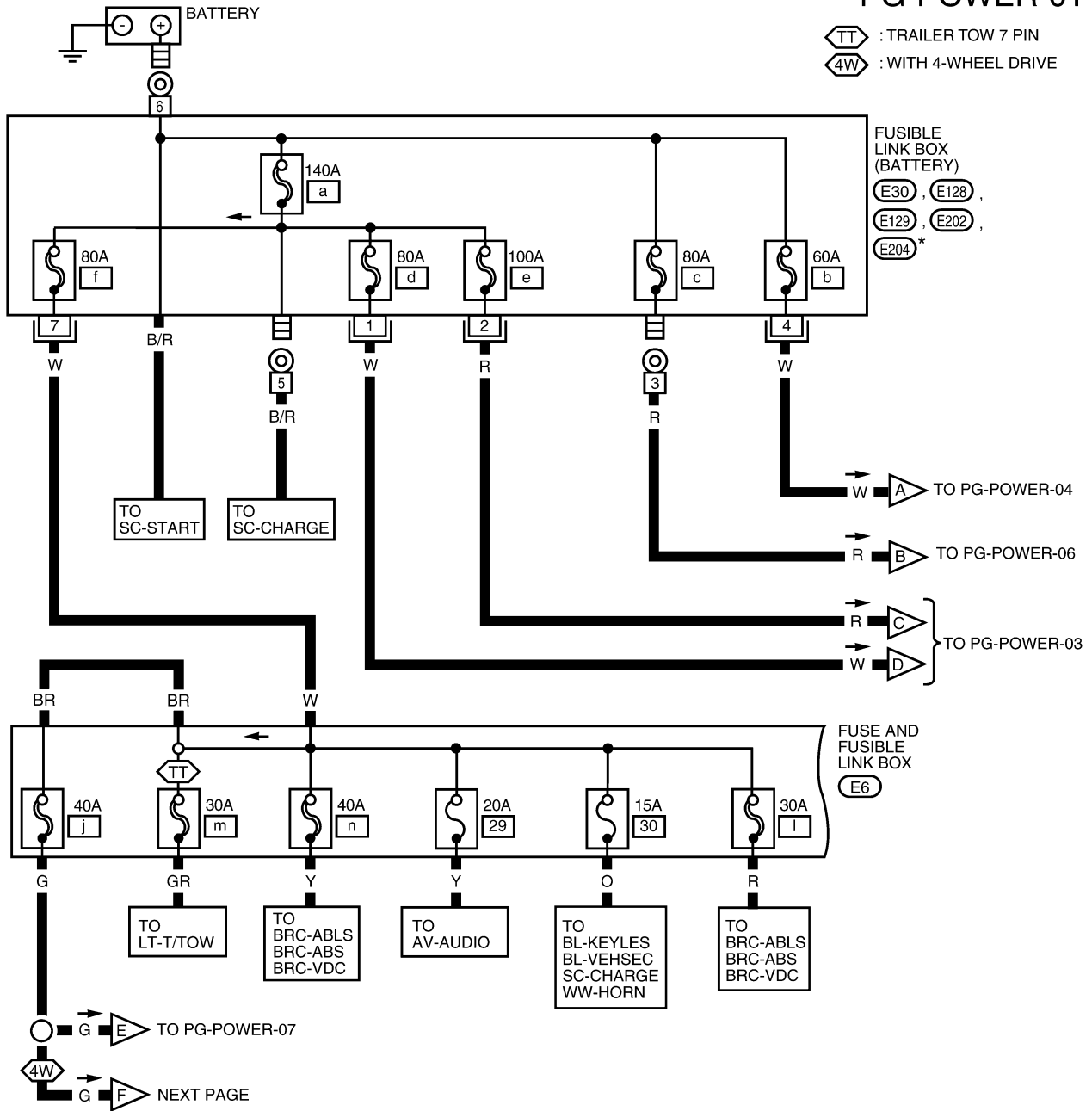

\*: (E204) IS AN INTEGRAL PART OF FUSIBLE LINK BOX (BATTERY).

WKWA5500E

# POWER SUPPLY ROUTING CIRCUIT

PG-POWER-02

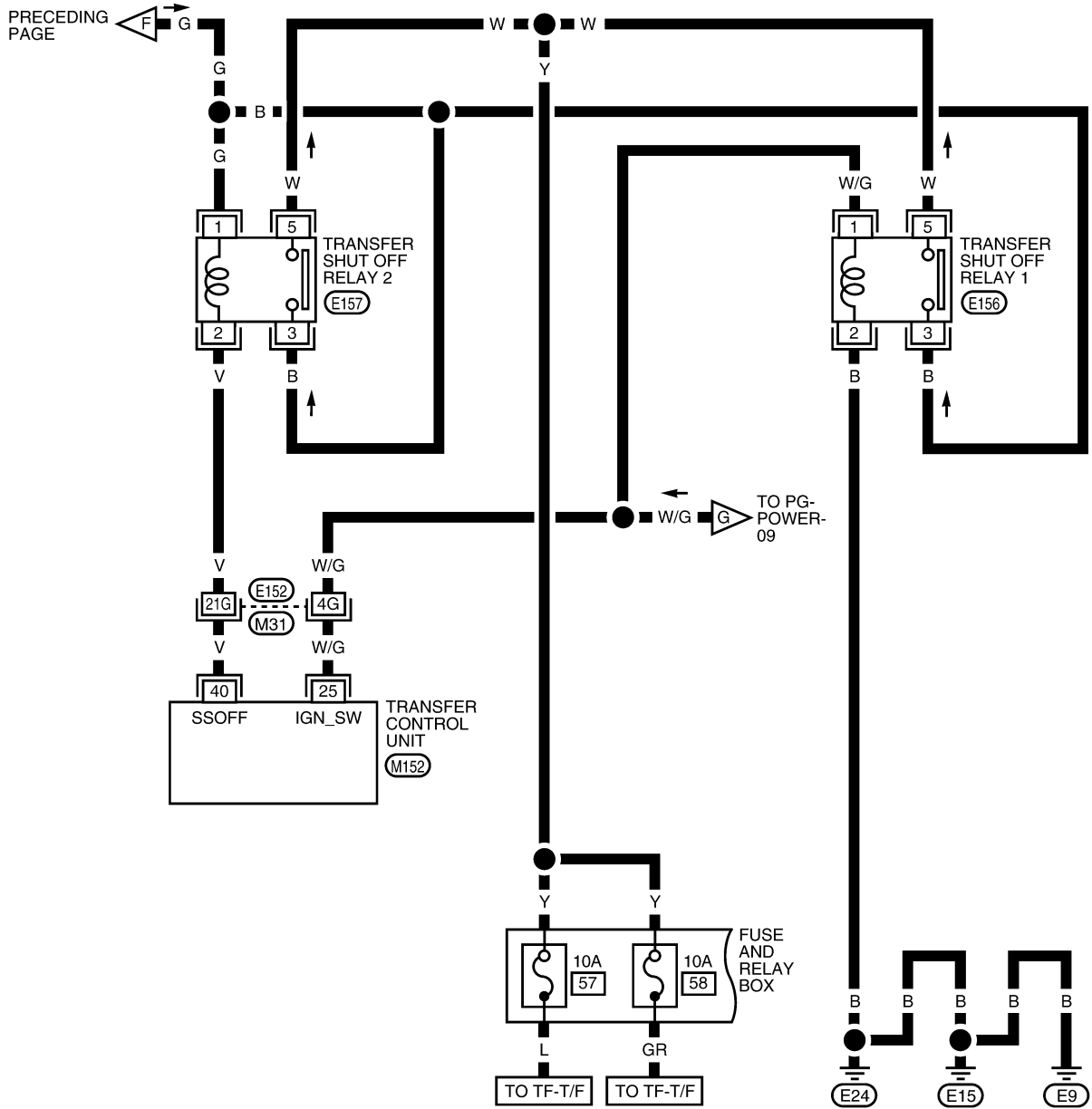

A  
B  
C  
D  
E  
F  
G  
H  
I  
J  
PG  
L  
M

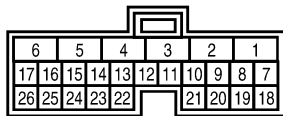

REFER TO THE FOLLOWING.  
 (M31) - SUPER MULTIPLE JUNCTION (SMJ)

WKWA4466E

# POWER SUPPLY ROUTING CIRCUIT

PG-POWER-03

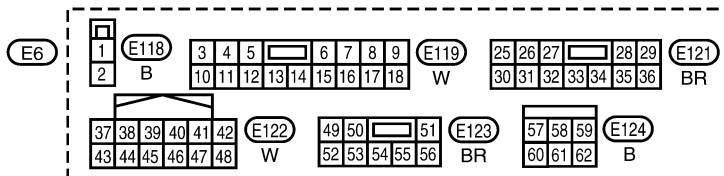
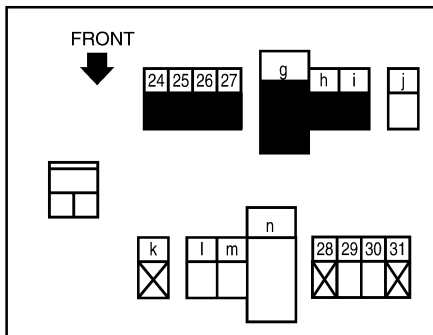
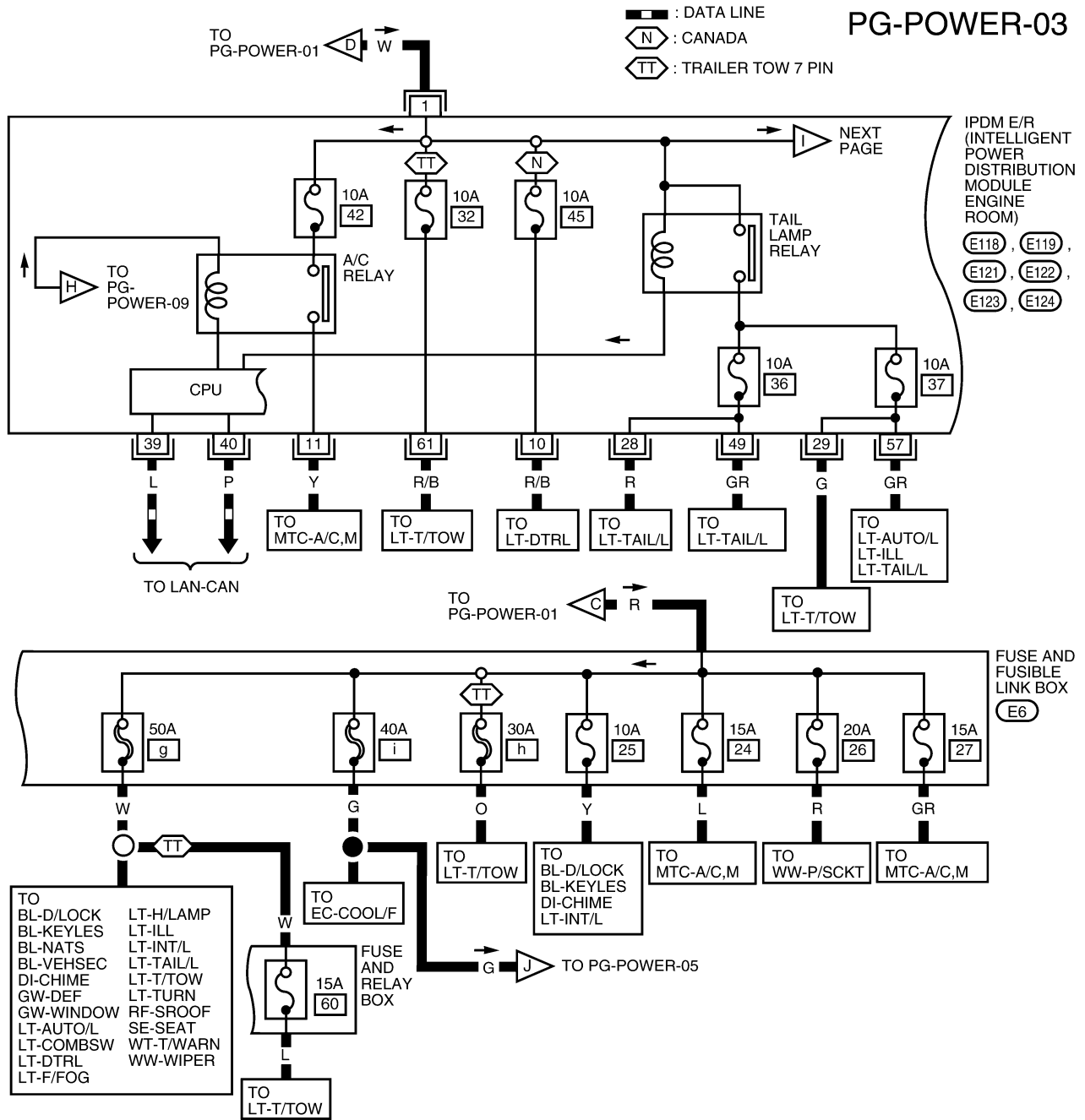

WKWA4467E



# POWER SUPPLY ROUTING CIRCUIT

PG-POWER-04

FL : WITH FRONT FOG LAMPS

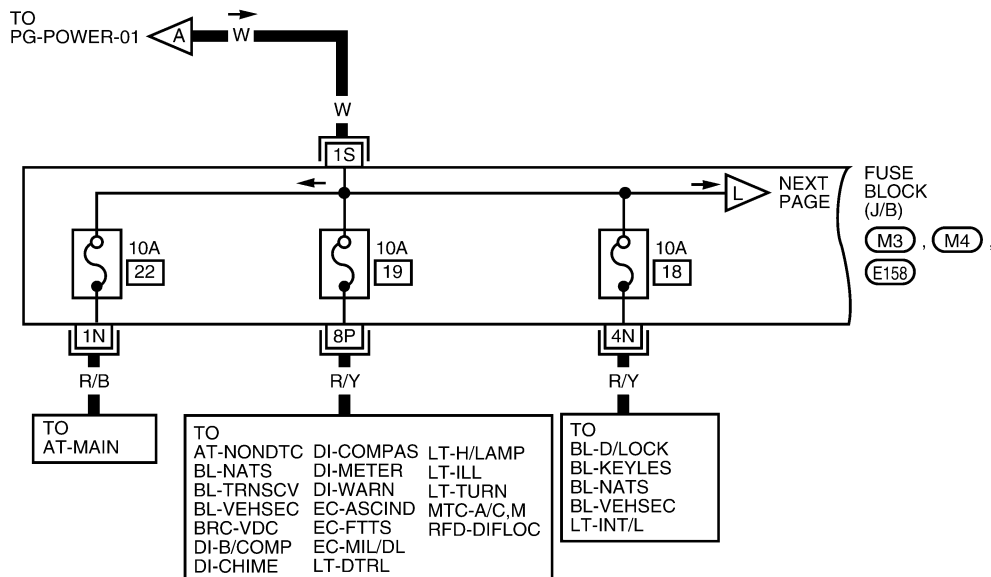
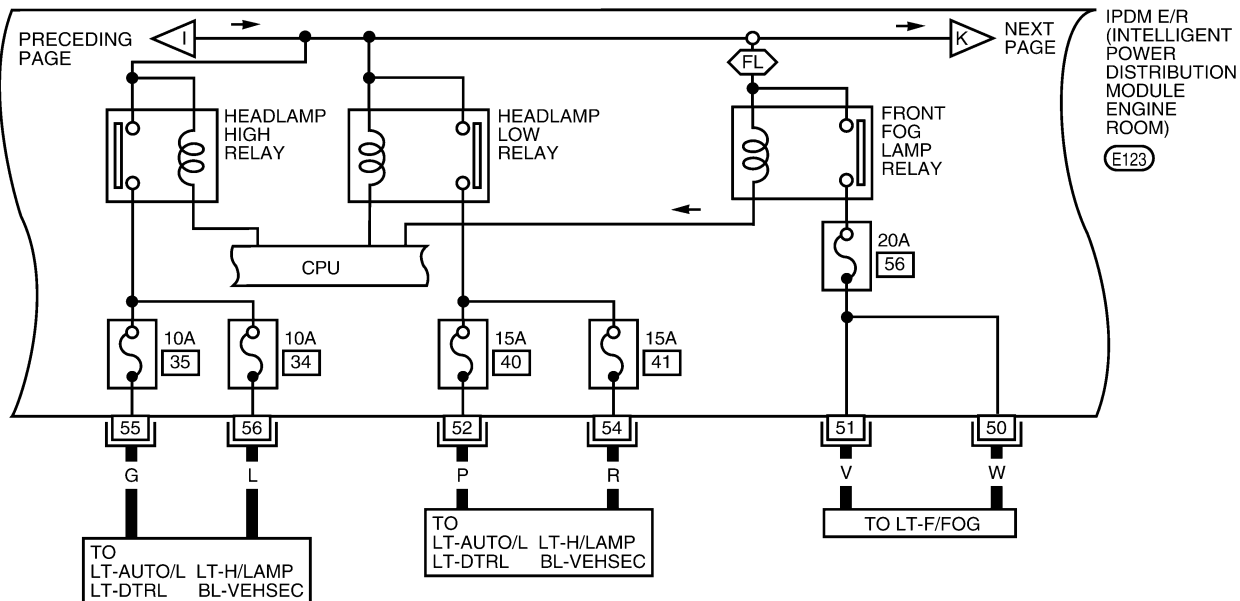

49 50 51 E123  
52 53 54 55 56 BR

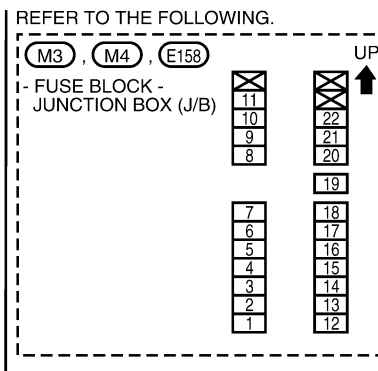

# POWER SUPPLY ROUTING CIRCUIT

## PG-POWER-05

: WITH HEATED MIRRORS

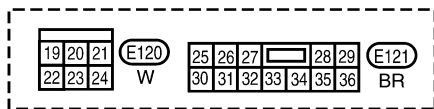
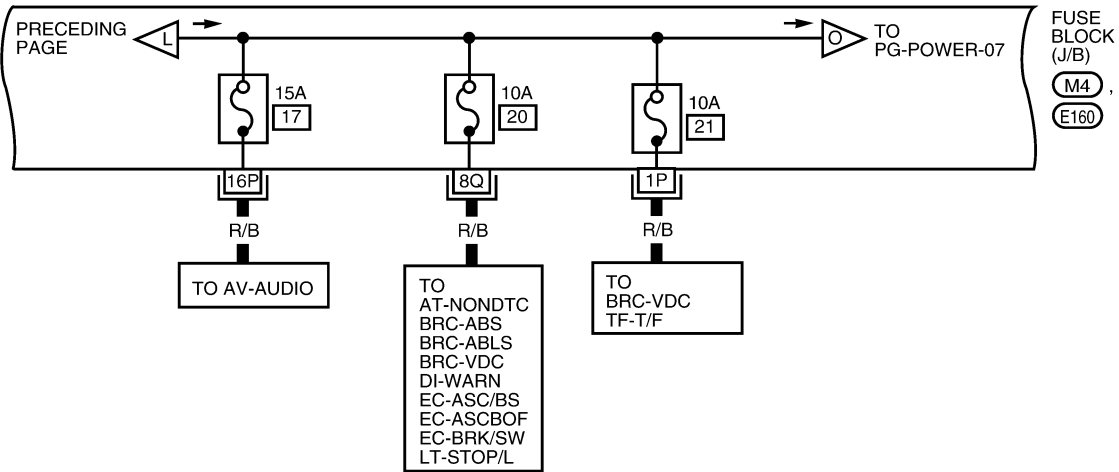
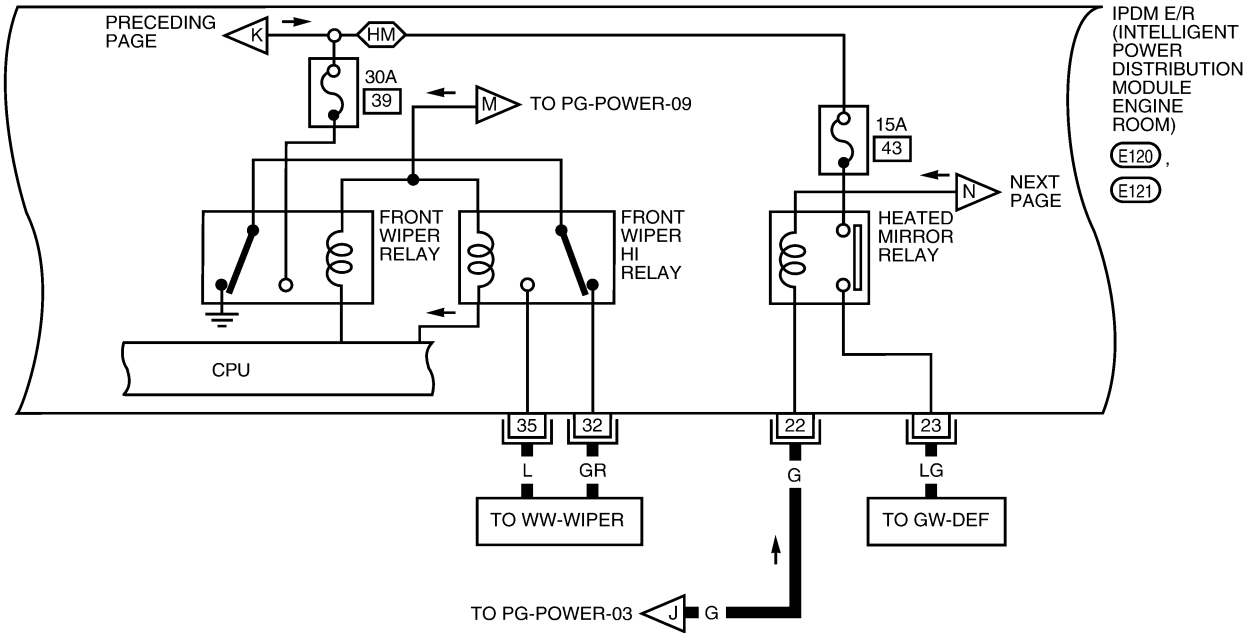

REFER TO THE FOLLOWING.

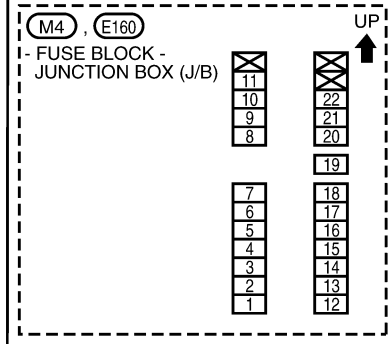

WKWA4469E

# POWER SUPPLY ROUTING CIRCUIT

## PG-POWER-06

TO PG-POWER-01

CC : CREW CAB

HM : WITH HEATED MIRRORS

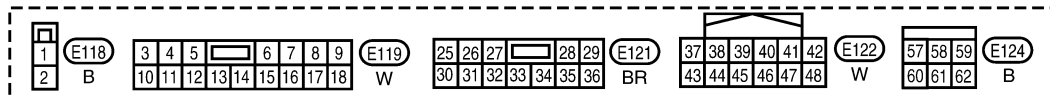
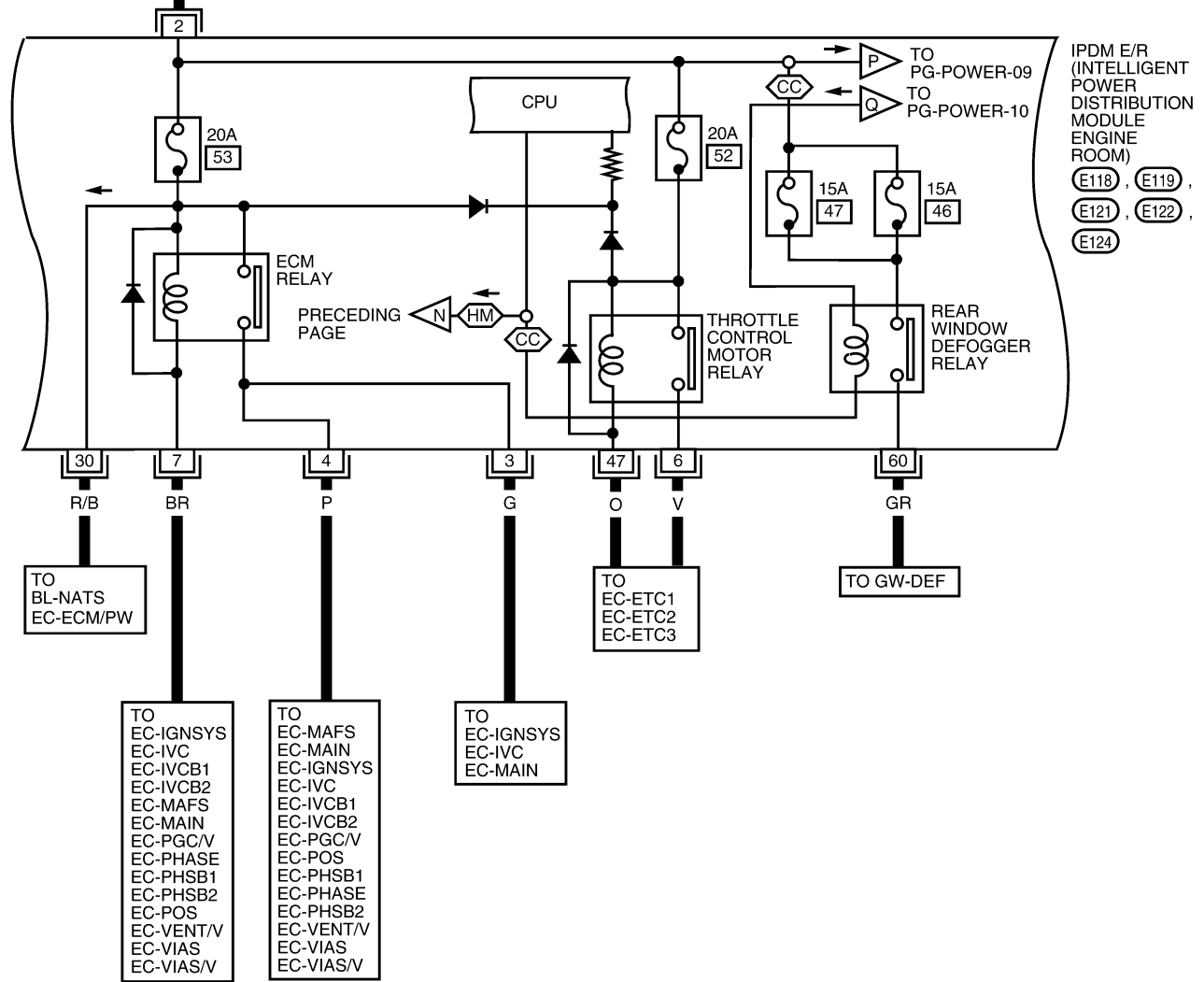

WKWA5501E

# POWER SUPPLY ROUTING CIRCUIT

## ACCESSORY POWER SUPPLY — IGNITION SW. IN ACC OR ON

PG-POWER-07

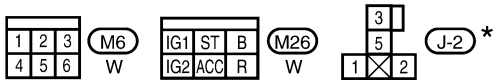
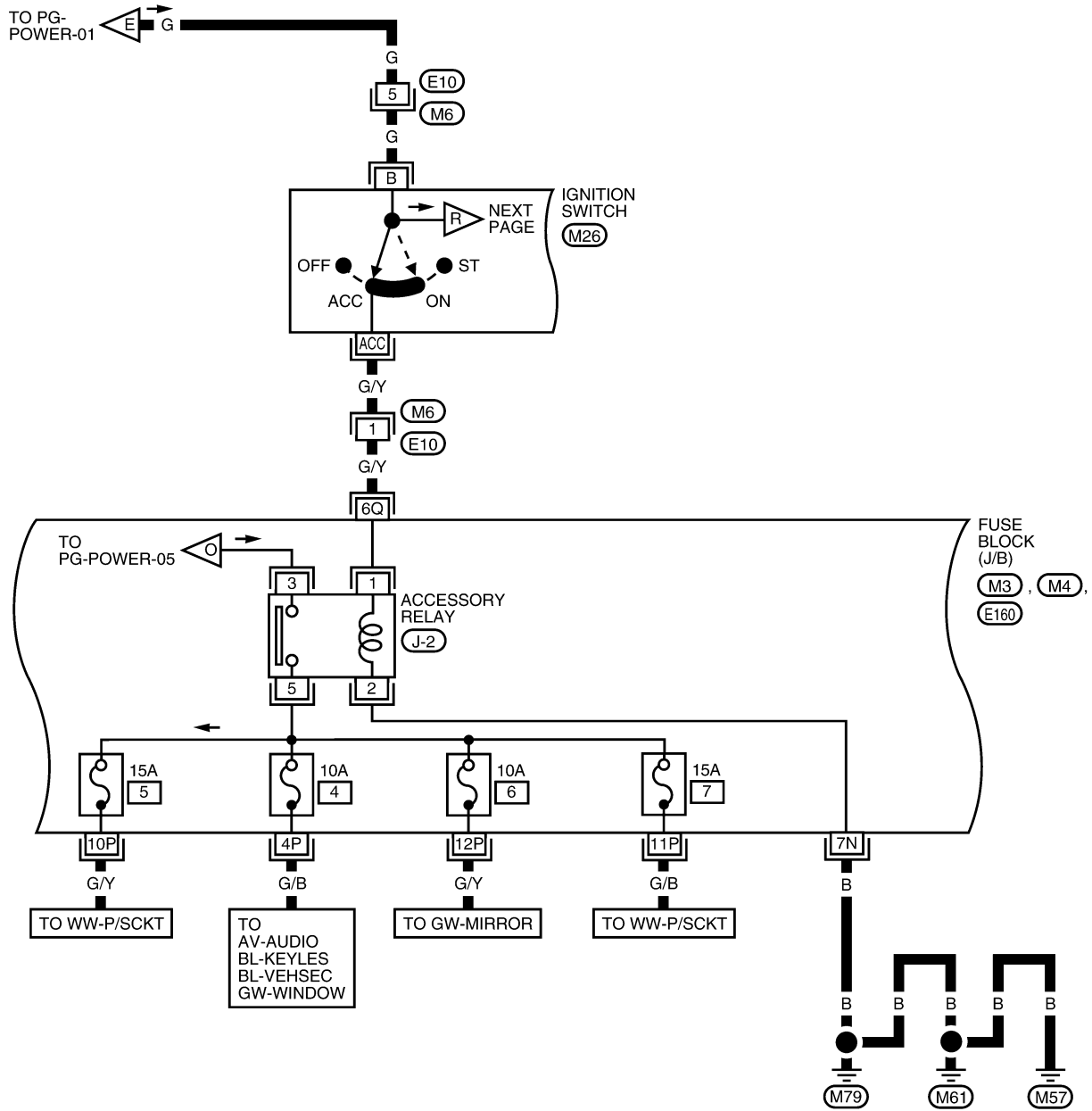

REFER TO THE FOLLOWING.

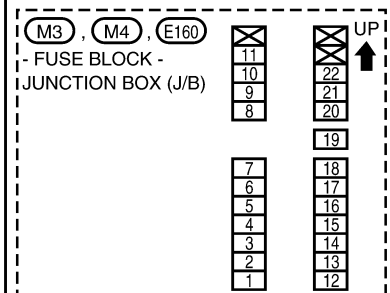

\* : THIS CONNECTOR IS NOT SHOWN IN "HARNESS LAYOUT".

WKWA5502E

# POWER SUPPLY ROUTING CIRCUIT

## IGNITION POWER SUPPLY — IGNITION SW. IN ON

PG-POWER-08

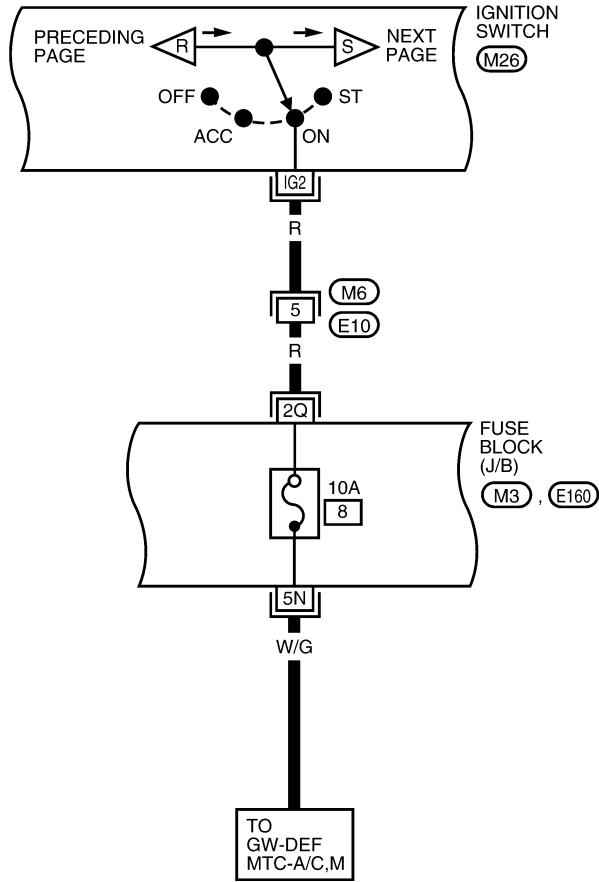

REFER TO THE FOLLOWING.

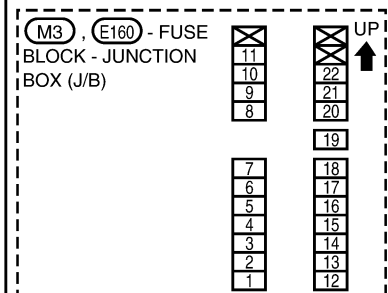

WKWA5503E

# POWER SUPPLY ROUTING CIRCUIT



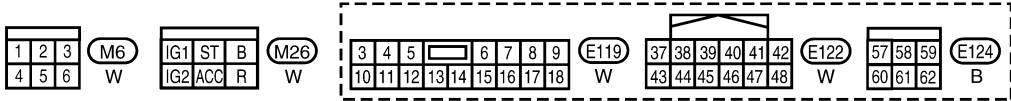
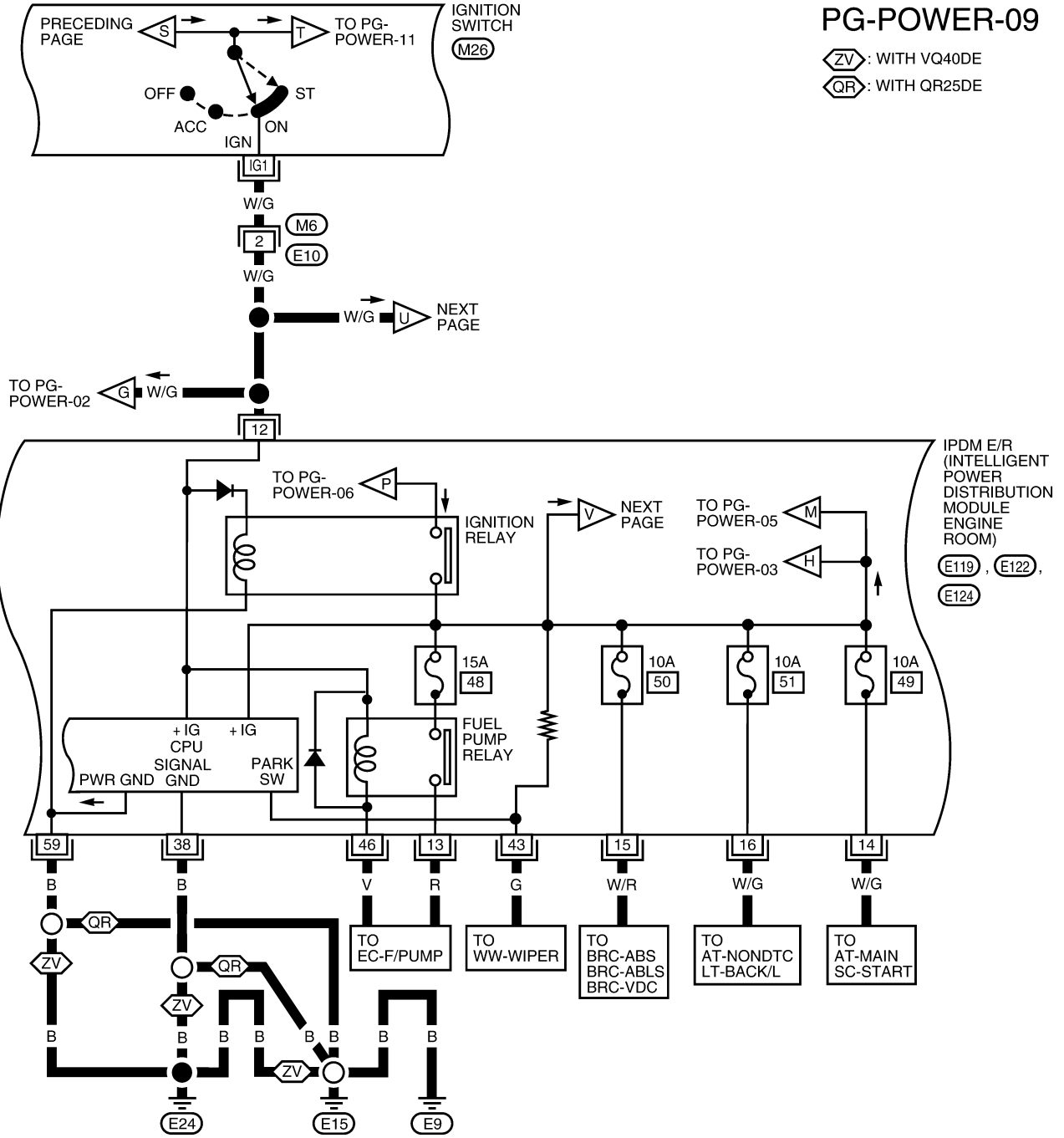

## IGNITION POWER SUPPLY — IGNITION SW. IN ON AND/OR START



WKWA5504E

# POWER SUPPLY ROUTING CIRCUIT

## PG-POWER-10

-  : CREW CAB
-  : WITH QR25DE
-  : WITH VQ40DE
-  : 10A
-  : 15A

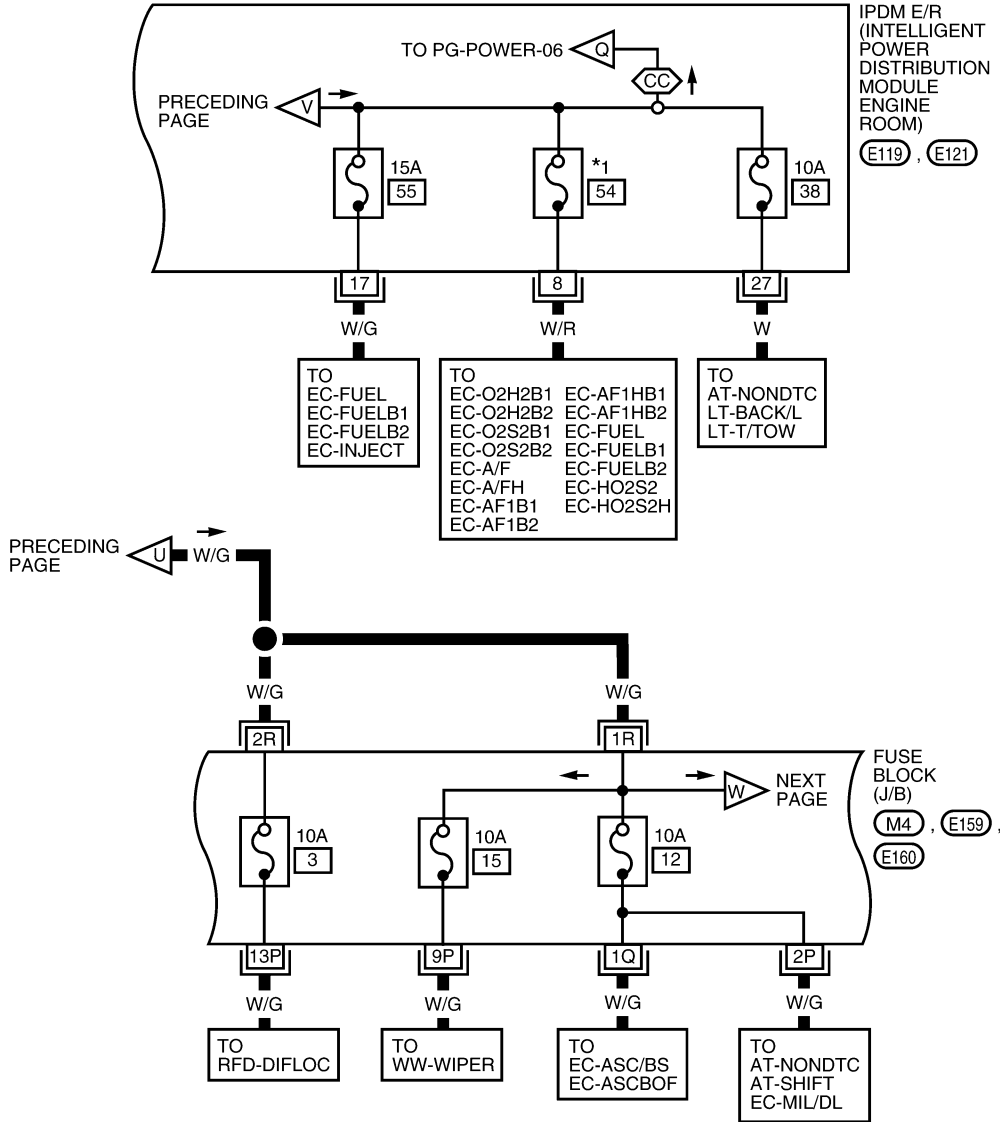

3	4	5	6	7	8	9	(E119)	25	26	27	28	29	(E121)
10	11	12	13	14	15	16	W	30	31	32	33	34	BR

REFER TO THE FOLLOWING.

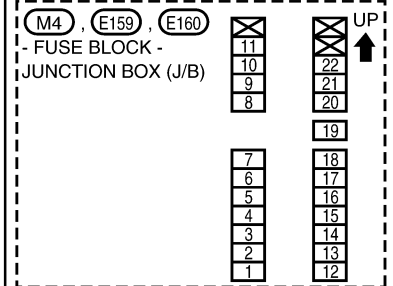

WKWA5505E

# POWER SUPPLY ROUTING CIRCUIT

## IGNITION POWER SUPPLY — IGNITION SWITCH IN START

PG-POWER-11

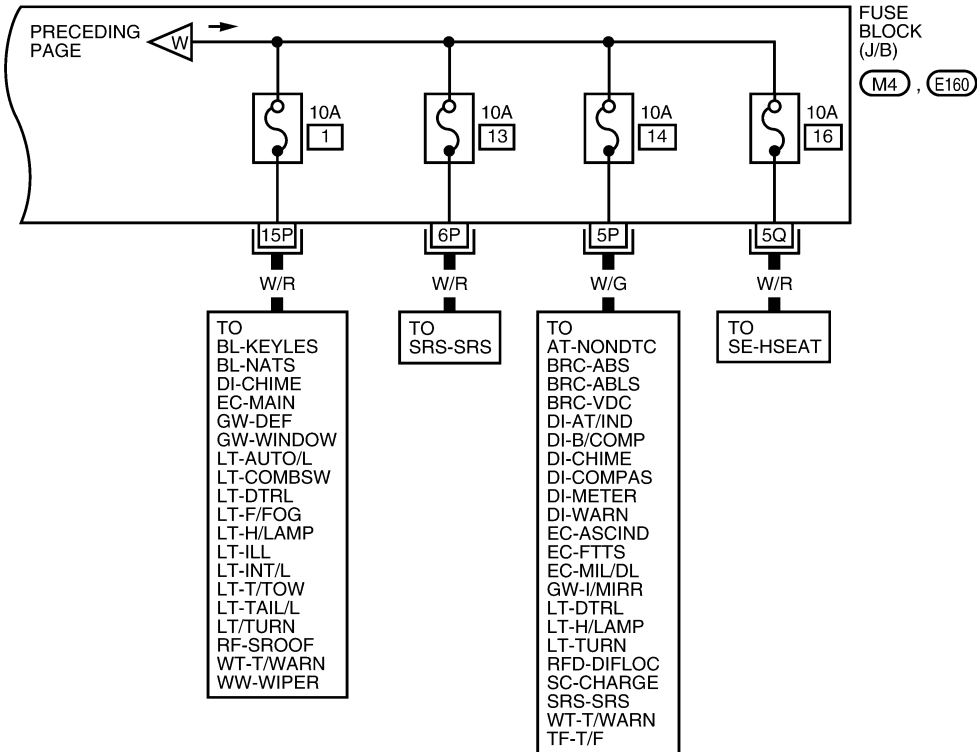
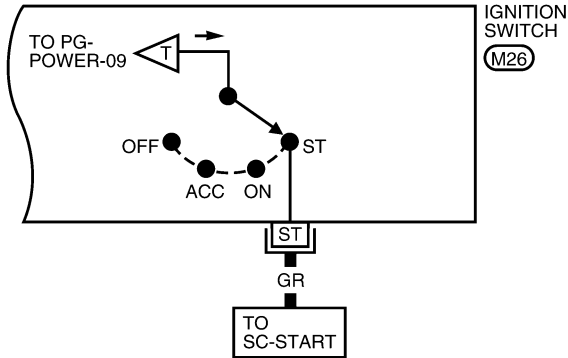

REFER TO THE FOLLOWING:

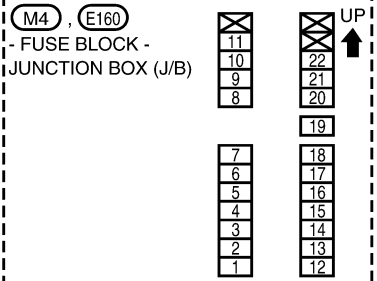

WKWA4474E



# POWER SUPPLY ROUTING CIRCUIT

## Fuse

EKS00HMD

- If fuse is blown, be sure to eliminate cause of incident before installing new fuse.
- Use fuse of specified rating. Never use fuse of more than specified rating.
- Do not partially install fuse; always insert it into fuse holder properly.
- Remove fuse for "ELECTRICAL PARTS (BAT)" if vehicle is not used for a long period of time.

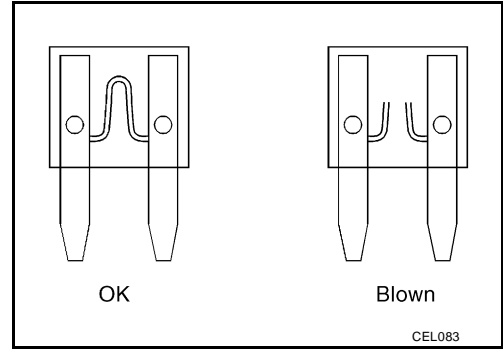

## Fusible Link

EKS00HME

A melted fusible link can be detected either by visual inspection or by feeling with finger tip. If its condition is questionable, use circuit tester or test lamp.

### CAUTION:

- If fusible link should melt, it is possible that critical circuit (power supply or large current carrying circuit) is shorted. In such a case, carefully check and eliminate cause of incident.
- Never wrap outside of fusible link with vinyl tape.
- Never let fusible link touch any other wiring harness, vinyl or rubber parts.

## Circuit Breaker (Built Into BCM)

EKS00HMF

For example, when current is 30A, the circuit is broken within 8 to 20 seconds.

A circuit breaker is used for the following systems:

- Sunroof

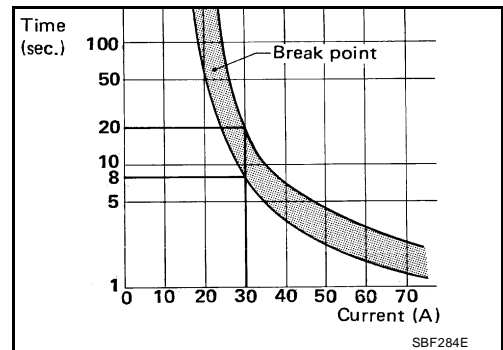

# IPDM E/R (INTELLIGENT POWER DISTRIBUTION MODULE ENGINE ROOM)

## IPDM E/R (INTELLIGENT POWER DISTRIBUTION MODULE ENGINE ROOM)

PF:284B7

### System Description

EKS00E0H

- IPDM E/R (Intelligent Power Distribution Module Engine Room) integrates the relay box and fuse block which were originally placed in engine compartment. It controls integrated relays via IPDM E/R control circuits.
- IPDM E/R-integrated control circuits perform ON-OFF operation of relays, CAN communication control, etc.
- It controls operation of each electrical component via ECM, BCM and CAN communication lines.

#### CAUTION:

**None of the IPDM E/R integrated relays can be removed.**

### SYSTEMS CONTROLLED BY IPDM E/R

1. Lamp control  
Using CAN communication lines, it receives signals from the BCM and controls the following lamps:
  - Headlamps (High, Low)
  - Daytime light relay control (Canada only)
  - Parking lamps
  - Tail and license plate lamps
  - Front fog lamps
2. Wiper control  
Using CAN communication lines, it receives signals from the BCM and controls the front wipers.
3. Daytime light relay control  
Using CAN communication lines, it receives signals from the BCM and controls the daytime light relay.
4. Generator control  
Using CAN communication lines, it receives signals from the ECM and controls power generation output.
5. Rear window defogger relay control (Crew cab only)  
Using CAN communication lines, it receives signals from the BCM and controls the rear window defogger relay.
6. A/C compressor control  
Using CAN communication lines, it receives signals from the BCM and controls the A/C compressor (magnet clutch).
7. Starter control  
Using CAN communication lines, it receives signals from the BCM and controls the starter relay.
8. Cooling fan control  
Using CAN communication lines, it receives signals from the ECM and controls the cooling fan relays.
9. Horn control  
Using CAN communication lines, it receives signals from the BCM and controls the horn relay.

### CAN COMMUNICATION LINE CONTROL

With CAN communication, by connecting each control unit using two communication lines (CAN L-line, CAN H-line), it is possible to transmit a maximum amount of information with minimum wiring. Each control unit can transmit and receive data, and reads necessary information only.

1. Fail-safe control
  - When CAN communication with other control units is impossible, IPDM E/R performs fail-safe control. After CAN communication returns to normal operation, it also returns to normal control.
  - Operation of control parts by IPDM E/R during fail-safe mode is as follows:

Controlled system	Fail-safe mode
Headlamp	<ul style="list-style-type: none"><li>● With the ignition switch ON, the headlamp low is ON.</li><li>● With the ignition switch OFF, the headlamp low is OFF.</li></ul>
Tail license plate and parking lamps	<ul style="list-style-type: none"><li>● With the ignition switch ON, the tail lamp relay is ON.</li><li>● With the ignition switch OFF, the tail lamp relay is OFF.</li></ul>

# IPDM E/R (INTELLIGENT POWER DISTRIBUTION MODULE ENGINE ROOM)

Controlled system	Fail-safe mode
Cooling fan	<ul style="list-style-type: none"> <li>● With the ignition switch ON, the cooling fan HI operates.</li> <li>● With the ignition switch OFF, the cooling fan stops.</li> </ul>
Front wiper	Until the ignition switch is turned off, the front wiper LO and HI remains in the same status it was in just before fail-safe control was initiated.
Rear window defogger	Rear window defogger relay OFF
A/C compressor	A/C compressor OFF
Front fog lamps	Front fog lamp relay OFF

## IPDM E/R STATUS CONTROL

In order to save power, IPDM E/R switches status by itself based on each operating condition.

- CAN communication status
  - CAN communication is normally performed with other control units.
  - Individual unit control by IPDM E/R is normally performed.
  - When sleep request signal is received from BCM, mode is switched to sleep waiting status.
- Sleep waiting status
  - Process to stop CAN communication is activated.
  - All systems controlled by IPDM E/R are stopped. When 3 seconds have elapsed after CAN communication with other control units is stopped, mode switches to sleep status.
- Sleep status
  - IPDM E/R operates in low current-consumption mode.
  - CAN communication is stopped.
  - When a change in CAN communication signal is detected, mode switches to CAN communication status.
  - When a change in ignition switch signal is detected, mode switches to CAN communication status.

## CAN Communication System Description

EKS00E0I

Refer to [LAN-4, "SYSTEM DESCRIPTION"](#).

## Function of Detecting Ignition Relay Malfunction

EKS00E0J

- When the integrated ignition relay is stuck in a "closed contact" position and cannot be turned OFF, IPDM E/R turns ON tail and parking lamps for 10 minutes to indicate IPDM E/R malfunction.
- When the state of the integrated ignition relay does not agree with the state of the ignition switch signal received via CAN communication, the IPDM E/R activates the tail lamp relay.

Ignition switch signal	Ignition relay status	Tail lamp relay
ON	ON	—
OFF	OFF	—
ON	OFF	—
OFF	ON	ON (10 minutes)

### NOTE:

When the ignition switch is turned ON, the tail lamps are OFF.

# IPDM E/R (INTELLIGENT POWER DISTRIBUTION MODULE ENGINE ROOM)

## CONSULT-II Function (IPDM E/R)

EKS00EOK

CONSULT-II can display each diagnostic item using the diagnostic test modes shown following.

IPDM E/R Diagnostic Mode	Description
SELF-DIAG RESULTS	Displays IPDM E/R self-diagnosis results.
DATA MONITOR	Displays IPDM E/R input/output data in real time.
CAN DIAG SUPPORT MNTR	The result of transmit/receive diagnosis of CAN communication can be read.
ACTIVE TEST	Operation of electrical loads can be checked by sending drive signal to them.

## CONSULT-II START PROCEDURE

Refer to [GI-38, "CONSULT-II Start Procedure"](#).

## SELF-DIAGNOSTIC RESULTS

### Display Item List

Display items	CONSULT-II display code	Malfunction detection	TIME		Possible causes
			CRNT	PAST	
NO DTC IS DETECTED. FURTHER TESTING MAY BE REQUIRED.	—	—	—	—	—
CAN COMM CIRC	U1000	<ul style="list-style-type: none"> <li>● If CAN communication reception/transmission data has a malfunction, or if any of the control units fail, data reception/transmission cannot be confirmed.</li> <li>● When the data in CAN communication is not received before the specified time.</li> </ul>	X	X	Any of items listed below have errors: <ul style="list-style-type: none"> <li>● TRANSMIT DIAG</li> <li>● ECM</li> <li>● BCM/SEC</li> </ul>

### NOTE:

The details for display of the period are as follows:

- CRNT: Error currently detected with IPDM E/R.
- PAST: Error detected in the past and placed in IPDM E/R memory.

# IPDM E/R (INTELLIGENT POWER DISTRIBUTION MODULE ENGINE ROOM)

## DATA MONITOR

### All Signals, Main Signals, Selection From Menu

Item name	CONSULT-II screen display	Display or unit	Monitor item selection			Description
			ALL SIGNALS	MAIN SIGNALS	SELECTION FROM MENU	
Motor fan request	MOTOR FAN REQ	1/2/3/4	X	X	X	Signal status input from ECM
Compressor request	AC COMP REQ	ON/OFF	X	X	X	Signal status input from BCM
Parking, license plate, and tail lamp request	TAIL & CLR REQ	ON/OFF	X	X	X	Signal status input from BCM
Headlamp low beam request	HL LO REQ	ON/OFF	X	X	X	Signal status input from BCM
Headlamp high beam request	HL HI REQ	ON/OFF	X	X	X	Signal status input from BCM
Front fog lamps request	FR FOG REQ	ON/OFF	X	X	X	Signal status input from BCM
Front wiper request	FR WIP REQ	STOP/1LO/LO/HI	X	X	X	Signal status input from BCM
Wiper auto stop	WIP AUTO STOP	ACT P/STOP P	X	X	X	Output status of IPDM E/R
Wiper protection	WIP PROT	OFF/LS/HS/BLOCK	X	X	X	Control status of IPDM E/R
Starter request	ST RLY REQ	ON/OFF	X		X	Signal status input from BCM
Ignition relay status	IGN RLY	ON/OFF	X	X	X	Ignition relay status monitored with IPDM E/R
Rear defogger request	RR DEF REQ	ON/OFF	X	X	X	Signal status input from BCM
Hood switch	HOOD SW (*1)	OFF	X			Signal status input from IPDM E/R
Theft warning horn request	THFT HRN REQ	ON/OFF	X		X	Signal status input from BCM
Horn chirp	HORN CHIRP	ON/OFF	X		X	Output status of IPDM E/R
Daytime lights request	DTRL REQ	ON/OFF	X		X	Signal status input from BCM
Oil pressure switch	OIL P SW	OPEN/CLOSE	X		X	Signal status input from IPDM E/R

#### NOTE:

- Perform monitoring of IPDM E/R data with the ignition switch ON. When the ignition switch is in ACC position, display may not be correct.
- (\*1) This item is displayed, but does not function.

#### CAN DIAG SUPPORT MNTR

Refer to [LAN-4, "SYSTEM DESCRIPTION"](#) .

#### ACTIVE TEST

##### Display Item List

Test name	CONSULT-II screen display	Description
Rear defogger output	REAR DEFOGGER	With a certain ON-OFF operation, the rear defogger relay can be operated.
Front wiper (HI, LO) output	FRONT WIPER	With a certain operation (OFF, HI ON, LO ON), the front wiper relay (Lo, Hi) can be operated.

## IPDM E/R (INTELLIGENT POWER DISTRIBUTION MODULE ENGINE ROOM)

Test name	CONSULT-II screen display	Description
Cooling fan output	MOTOR FAN	With a certain operation (1, 2, 3, 4), the cooling fan can be operated.
Headlamp relay (HI, LO) output	EXTERNAL LAMPS	With a certain operation (OFF, HI ON, LO ON, TAIL ON, FOG ON), the lamp relay (Low, High, Tail, Fog) can be operated.
Front fog lamp relay (FOG) output	EXTERNAL LAMPS	With a certain operation (OFF, HI ON, LO ON, TAIL ON, FOG ON), the lamp relay (Low, High, Tail, Fog) can be operated.
Tail lamp relay output	EXTERNAL LAMPS	With a certain operation (OFF, HI ON, LO ON, TAIL ON, FOG ON), the lamp relay (Low, High, Tail, Fog) can be operated.
Horn output	HORN	With a certain ON-OFF operation, the horn relay can be operated.

# IPDM E/R (INTELLIGENT POWER DISTRIBUTION MODULE ENGINE ROOM)

EKS00EOL

## Auto Active Test

### DESCRIPTION

- In auto active test mode, operation inspection can be performed when IPDM E/R sends a drive signal to the following systems:
  - Rear window defogger (Crew cab only)
  - Front wipers
  - Tail, license plate, front fog, and parking lamps
  - Headlamps (High, Low)
  - A/C compressor (magnet clutch)
  - Cooling fan

### OPERATION PROCEDURE

1. Close hood and front door RH, and lift wiper arms away from windshield (to prevent glass damage by wiper operation).

**NOTE:**

When auto active test is performed with hood opened, sprinkle water on windshield beforehand.

2. Turn ignition switch OFF.
3. Turn ignition switch ON and, within 20 seconds, press front door switch LH 10 times. Then turn ignition switch OFF.
4. Turn ignition switch ON within 10 seconds after ignition switch OFF.
5. When auto active test mode is actuated, horn chirps once.
6. After a series of operations is repeated three times, auto active test is completed.

**NOTE:**

When auto active test mode has to be cancelled halfway, turn ignition switch OFF.

**CAUTION:**

Be sure to perform [BL-33. "Door Switch Check \(King Cab\)"](#) or [BL-35. "Door Switch Check \(Crew Cab\)"](#) when the auto active test cannot be performed.

### INSPECTION IN AUTO ACTIVE TEST MODE

When auto active test mode is actuated, the following six steps are repeated three times.

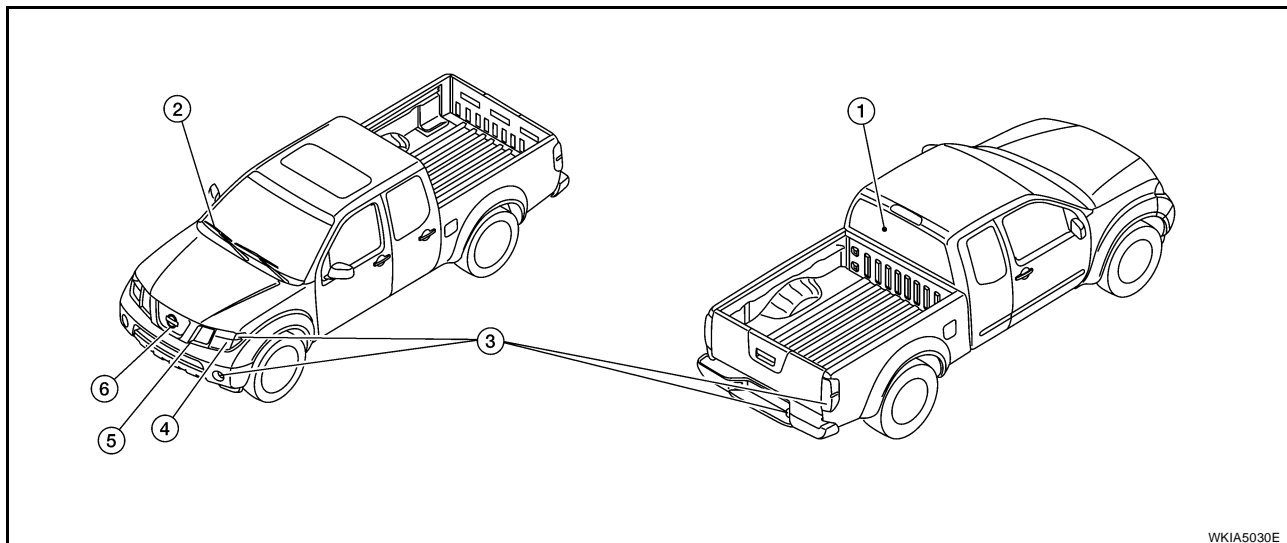

WKIA5030E

Item Number	Test Item	Operation Time/Frequency
1	Rear window defogger (Crew cab only)	10 seconds
2	Front wipers	LOW 5 seconds then HIGH 5 seconds
3	Tail, license plate, front fog and parking lamps	10 seconds
4	Headlamps	Low ON for 10 seconds, then High ON-OFF five times.

# IPDM E/R (INTELLIGENT POWER DISTRIBUTION MODULE ENGINE ROOM)

Item Number	Test Item	Operation Time/Frequency
5	A/C compressor (magnet clutch)	ON-OFF 5 times
6	Cooling fan	LOW 5 seconds then HIGH 5 seconds

## Concept of Auto Active Test

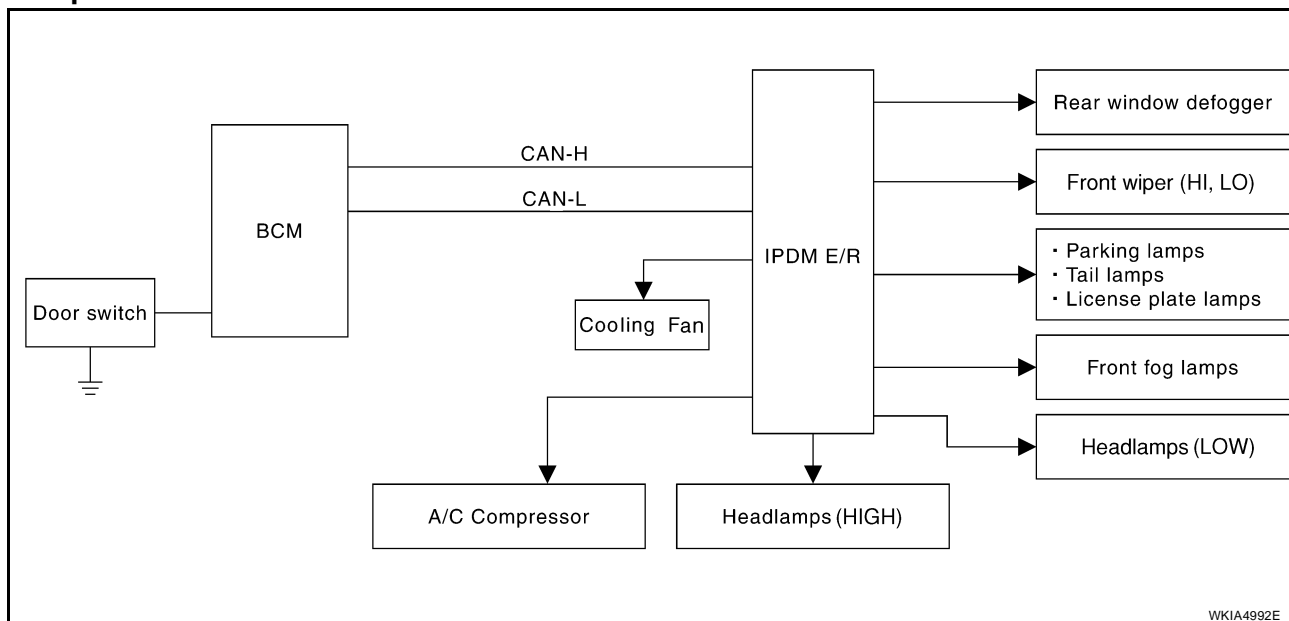

- IPDM E/R actuates auto active test mode when it receives door switch signal from BCM via CAN communication line. Therefore, when auto active test mode is activated successfully, CAN communication between IPDM E/R and BCM is normal.
- If any of the systems controlled by IPDM E/R cannot be operated, possible cause can be easily diagnosed using auto active test.

### Diagnosis chart in auto active test mode

Symptom	Inspection contents	Possible cause
Rear window defogger does not operate.	YES	● BCM signal input circuit
	NO	● Rear window defogger relay ● Open circuit of rear window defogger ● IPDM E/R malfunction ● Harness or connector malfunction between IPDM E/R and rear window defogger
Any of front wipers, tail and parking lamps, front fog lamps, and headlamps (High, Low) do not operate.	YES	● BCM signal input system
	NO	● Lamp/wiper motor malfunction ● Lamp/wiper motor ground circuit malfunction ● Harness/connector malfunction between IPDM E/R and system in question ● IPDM E/R (integrated relay) malfunction
A/C compressor does not operate.	YES	● BCM signal input circuit ● CAN communication signal between BCM and ECM ● CAN communication signal between ECM and IPDM E/R
	NO	● Magnet clutch malfunction ● Harness/connector malfunction between IPDM E/R and magnet clutch ● IPDM E/R (integrated relay) malfunction



# IPDM E/R (INTELLIGENT POWER DISTRIBUTION MODULE ENGINE ROOM)

Symptom	Inspection contents	Possible cause
Cooling fan does not operate.	Perform auto active test. Does cooling fan operate?	YES <ul style="list-style-type: none"> <li>● ECM signal input circuit</li> <li>● CAN communication signal between ECM and IPDM E/R</li> </ul>
		NO <ul style="list-style-type: none"> <li>● Cooling fan motor malfunction</li> <li>● Harness/connector malfunction between IPDM E/R and cooling fan motor</li> <li>● IPDM E/R (integrated relay) malfunction</li> </ul>

A

B

C

D

E

F

G

H

I

J

PG

L

M

# IPDM E/R (INTELLIGENT POWER DISTRIBUTION MODULE ENGINE ROOM)

## Schematic

EKS00EOM

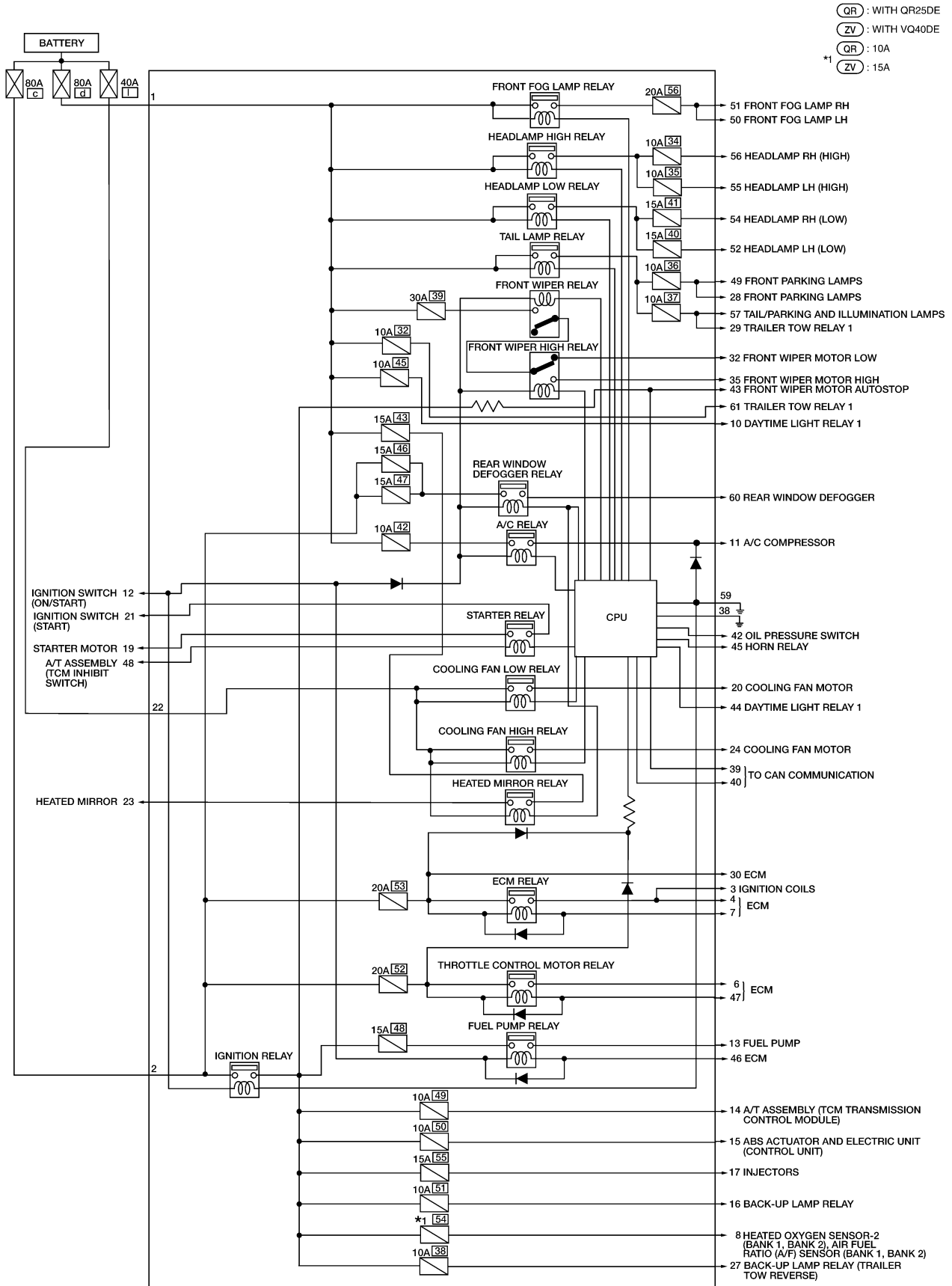

WKWA5506E

# IPDM E/R (INTELLIGENT POWER DISTRIBUTION MODULE ENGINE ROOM)

## IPDM E/R Terminal Arrangement

EKS00E0N

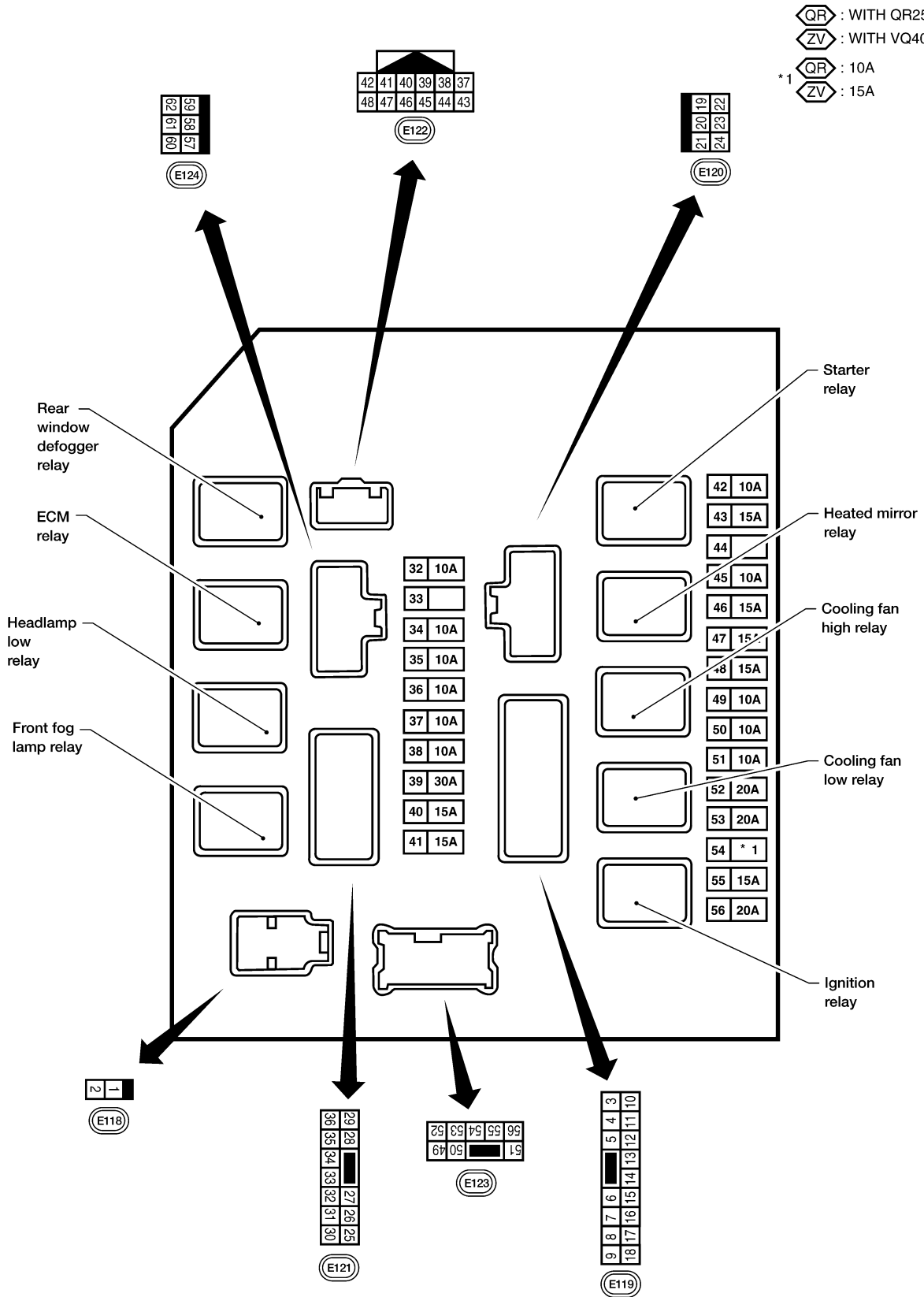

A  
B  
C  
D  
E  
F  
G  
H  
I  
J  
PG  
L  
M

# IPDM E/R (INTELLIGENT POWER DISTRIBUTION MODULE ENGINE ROOM)

## Terminals and Reference Values for IPDM E/R

EKS00HMB

Terminal	Wire color	Signal name	Signal input/output	Measuring condition		Reference value (Approx.)	
				Ignition switch	Operation or condition		
1	W	Battery power supply	Input	OFF	—	Battery voltage	
2	R	Battery power supply	Input	OFF	—	Battery voltage	
3	G	Ignition coil	Output	ON or START	—	Battery voltage	
4	P	ECM relay	Output	ON or START	—	Battery voltage	
6	V	Throttle control relay	Output	ON or START	—	Battery voltage	
7	BR	ECM relay control	Input	—	Ignition switch ON or START	0V	
					Ignition switch OFF or ACC	Battery voltage	
8	W/R	O2 and A/F sensor ignition supply	Output	ON or START	—	Battery voltage	
10	R/B	Battery power supply (daytime light relay)	Output	OFF	—	Battery voltage	
11	Y	A/C compressor	Output	ON	A/C switch or auto A/C request ON	Battery voltage	
12	W/G	Ignition switch	Input	—	OFF or ACC	0V	
13	R	Fuel pump relay	Output	—	OFF or ACC	0V	
					ON or START	Battery voltage	
14	W/G	A/T ignition supply	Output	ON or START	—	Battery voltage	
15	W/R	ABS ignition supply	Output	ON or START	—	Battery voltage	
16	W/G	Reverse lamp	Output	ON or START	—	Battery voltage	
17	W/G	Injector	Output	ON or START	—	Battery voltage	
19	W	Starter motor	Output	START	—	Battery voltage	
20	BR	Cooling fan motor (low)	Output	ON or START	—	Battery voltage	
21	GR	Ignition switch	Input	—	OFF or ACC or ON	0V	
					START	Battery voltage	
22	G	Battery power supply (cooling fan relays)	Input	OFF	—	Battery voltage	
23	LG	Heated mirror relay	Output	ON or START	Rear window defogger switch is ON	Battery voltage	
					Rear window defogger switch is OFF	0	
24	P	Cooling fan motor (high)	Output	ON or START	—	Battery voltage	
27	W	Trailer tow relay	Output	ON or START	—	Battery voltage	
28	R	LH front parking and front side marker lamp	Output	OFF	Lighting switch 1ST position	OFF	0V
					ON	Battery voltage	
29	G	Trailer tow relay	Output	OFF	Lighting switch 1ST position	OFF	0V
					ON	Battery voltage	

# IPDM E/R (INTELLIGENT POWER DISTRIBUTION MODULE ENGINE ROOM)

Terminal	Wire color	Signal name	Signal input/output	Measuring condition		Reference value (Approx.)	
				Ignition switch	Operation or condition		
30	R/B	Battery power supply (ECM)	Input	OFF	—	Battery voltage	
32	GR	Wiper low speed signal	Output	ON	Wiper switch	OFF	0V
						LO	Battery voltage
35	L	Wiper high speed signal	Output	ON	Wiper switch	OFF	0V
						HI	Battery voltage
37	Y	Generator	Output	ON		—	
38	B	Ground	Input	—	—	0V	
39	L	CAN-H	—	ON	—	—	
40	P	CAN-L	—	ON	—	—	
43	G	Wiper auto stop signal	Input	ON	Wiper in non-park position		Battery voltage
					Wiper in park position		0V
44	R	Daytime light relay 1 signal	Output	ON	Park brake switch position	OFF	0V
						ON	Battery voltage
45	LG	Horn relay	Input	OFF	When door locks are operated using keyfob	OFF	Battery voltage
						ON	0V
46	V	Fuel pump relay control	Input	—	Ignition switch ON or START		0V
					Ignition switch OFF or ACC		Battery voltage
47	O	Throttle control relay control	Input	—	Ignition switch ON or START		0V
					Ignition switch OFF or ACC		Battery voltage
48	R	Starter relay (inhibit switch)	Input	ON or START	Selector lever in "P" or "N"		Battery voltage
					Selector lever any other position		0V
49	GR	RH front parking and front side marker lamp	Output	OFF	Lighting switch 1ST position	OFF	
						ON	Battery voltage
50	W	Front fog lamp (LH)	Output	ON	Lighting switch must be in the 2ND position or AUTO position (LOW beam is ON) and the front fog lamp switch must be ON	OFF	0V
						ON	Battery voltage
51	V	Front fog lamp (RH)	Output	ON	Lighting switch must be in the 2ND position or AUTO position (LOW beam is ON) and the front fog lamp switch must be ON	OFF	0V
						ON	Battery voltage

A  
B  
C  
D  
E  
F  
G  
H  
I  
J

PG

L  
M

# IPDM E/R (INTELLIGENT POWER DISTRIBUTION MODULE ENGINE ROOM)

Terminal	Wire color	Signal name	Signal input/output	Measuring condition		Reference value (Approx.)	
				Ignition switch	Operation or condition		
52	P	Headlamp low (LH)	Output	OFF	Lighting switch 2ND position	OFF	0V
						ON	Battery voltage
54	R	Headlamp low (RH)	Output	OFF	Lighting switch 2ND position	OFF	0V
						ON	Battery voltage
55	G	Headlamp high (LH)	Output	OFF	Lighting switch HIGH or PASS position	OFF	0V
						ON	Battery voltage
56	L	Headlamp high (RH)	Output	OFF	Lighting switch HIGH or PASS position	OFF	0V
						ON	Battery voltage
57	GR	Rear parking, license, and tail lamp	Input	OFF	Lighting switch 1ST position	OFF	0V
						ON	Battery voltage
59	B	Ground	—	—	—	0V	
60	GR	Rear window defogger relay output signal	Output	ON	When rear window defogger switch is ON		Battery voltage
					When rear window defogger switch is OFF		0V
61	R/B	Battery power supply (trailer tow relay)	Output	OFF	—	Battery voltage	

## IPDM E/R Power/Ground Circuit Inspection

EKS00FPK

### 1. FUSE AND FUSIBLE LINK INSPECTION

Check that the following fusible links are not blown.

Terminal No.	Signal name	Fusible link No.
1, 2	Battery power	a, c, d

OK or NG

- OK >> GO TO 2.
- NG >> Replace fusible link.

### 2. POWER CIRCUIT INSPECTION

1. Turn ignition switch OFF.
2. Disconnect IPDM E/R harness connector E118.
3. Check voltage between IPDM E/R harness connector and ground.

Terminals		Voltage (Approx.)
(+)	(-)	
IPDM E/R connector	Terminal	
E118	1, 2	Ground
		Battery voltage

OK or NG

- OK >> GO TO 3.
- NG >> Repair or replace IPDM E/R power circuit harness.

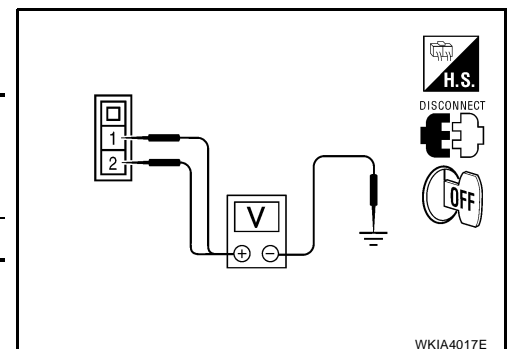

# IPDM E/R (INTELLIGENT POWER DISTRIBUTION MODULE ENGINE ROOM)

## 3. GROUND CIRCUIT INSPECTION

1. Disconnect IPDM E/R harness connectors E122 and E124.
2. Check continuity between IPDM E/R harness connectors E122 (A) terminal 38, E124 (B) terminal 59 and ground.

**Continuity should exist.**

OK or NG

- OK >> Inspection End.
- NG >> Repair or replace IPDM E/R ground circuit harness.

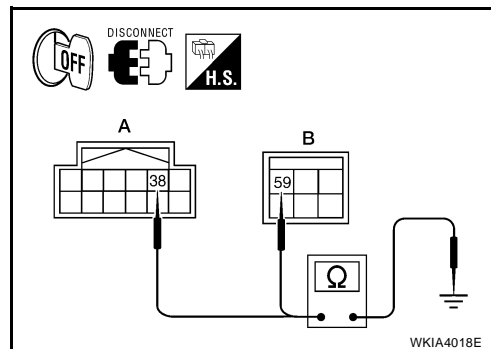

EKS00E0P

### Inspection with CONSULT-II (Self-Diagnosis)

**CAUTION:**

If a CONSULT-II is used with no connection of CONSULT-II CONVERTER, malfunctions might be detected in self-diagnosis depending on which control unit(s) carries out CAN communication.

#### 1. SELF-DIAGNOSIS RESULT CHECK

1. Connect CONSULT-II and select "IPDM E/R" on the "SELECT SYSTEM" screen.
2. Select "SELF-DIAG RESULTS" on the "SELECT DIAG MODE" screen.
3. Check display content in self-diagnosis results.

CONSULT-II Display	CONSULT-II display code	TIME		Details of diagnosis result
		CRNT	PAST	
NO DTC IS DETECTED. FURTHER TESTING MAY BE REQUIRED.	—	—	—	No malfunction
CAN COMM CIRC	U1000	X	X	Any of items listed below have errors: <ul style="list-style-type: none"> <li>● TRANSMIT DIAG</li> <li>● ECM</li> <li>● BCM/SEC</li> </ul>

**NOTE:**

The Details for Display for the Period are as follows:

- CRNT: Error currently detected by IPDM E/R.
- PAST: Error detected in the past and stored in IPDM E/R memory.

Contents displayed

NO DTC DETECTED. FURTHER TESTING MAY BE REQUIRED.>>Inspection End.

CAN COMM CIRC>>Print out the self-diagnosis result and refer to [LAN-4, "SYSTEM DESCRIPTION"](#) .

# IPDM E/R (INTELLIGENT POWER DISTRIBUTION MODULE ENGINE ROOM)

## Removal and Installation of IPDM E/R

EKS00E00

### REMOVAL

1. Disconnect negative battery cable.
2. Remove IPDM E/R upper cover.

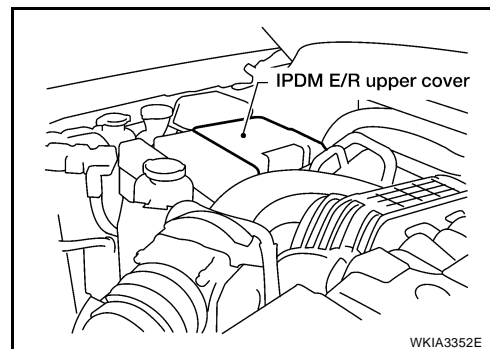

3. Release 2 clips and pull IPDM E/R up from case.
4. Disconnect IPDM E/R connectors and remove the IPDM E/R.

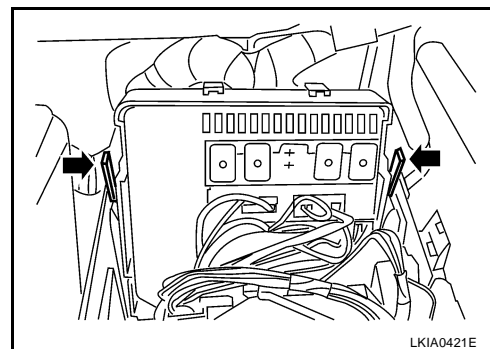

### INSTALLATION

Installation is in the reverse order of removal.



# GROUND CIRCUIT

PFP:24080

EKS00EOR

## GROUND CIRCUIT

### Ground Distribution MAIN HARNESS

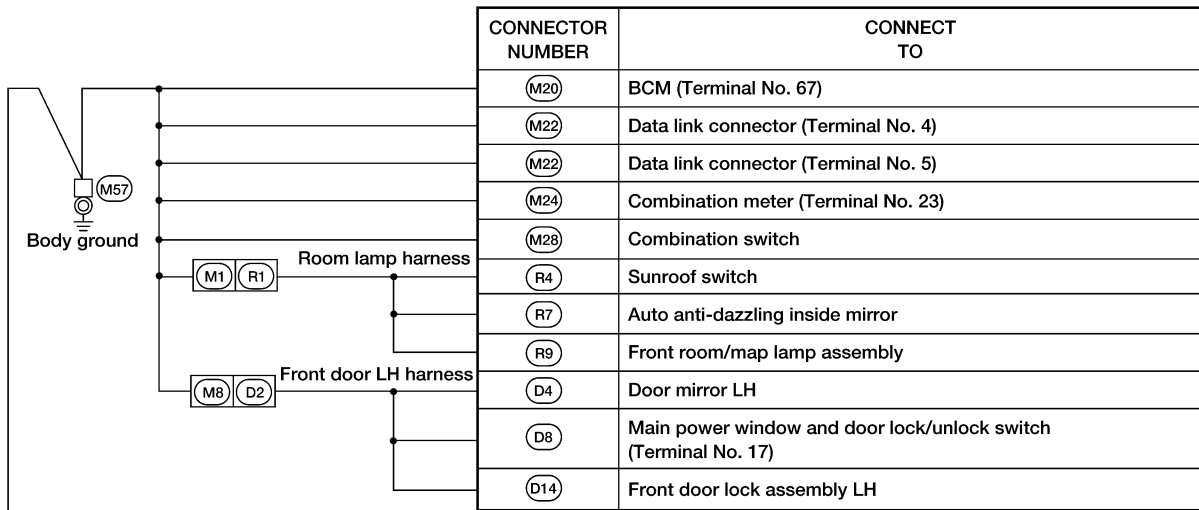
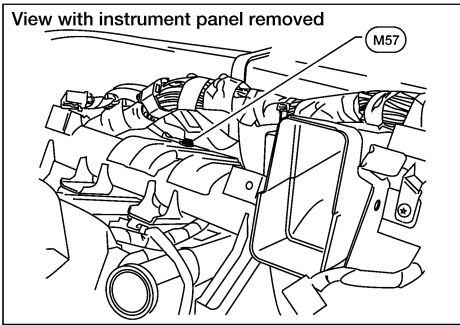

Next page

A  
B  
C  
D  
E  
F  
G  
H  
I  
J  
L  
M

PG

WKIA5872E

# GROUND CIRCUIT

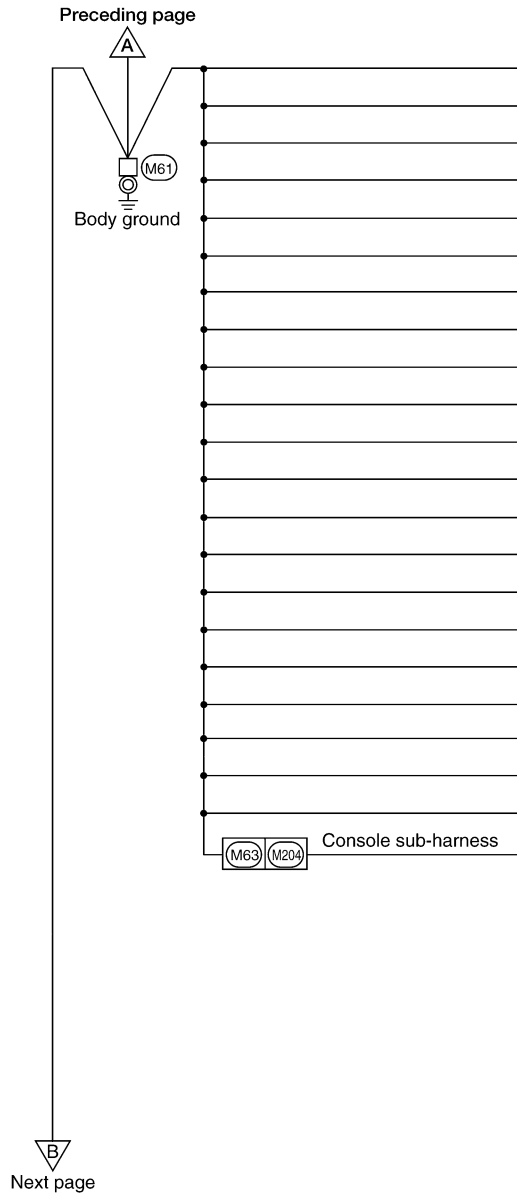
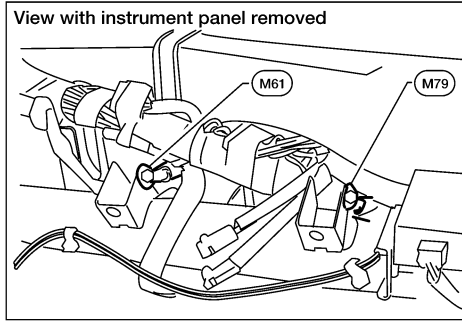

CONNECTOR NUMBER	CONNECT TO
(M13)	Front passenger air bag off indicator
(M21)	NATS antenna amp.
(M24)	Combination meter (Terminal No. 13)
(M35)	Air bag diagnosis sensor
(M47)	Steering angle sensor
(M49)	Front air control
(M51)	Front blower switch
(M55)	Hazard switch
(M71)	Cargo lamp switch
(M152)	Transfer control unit (Terminal No. 6)
(M152)	Transfer control unit (Terminal No. 18)
(M153)	Transfer control unit (Terminal No. 32)
(M154)	VDC off switch
(M155)	HDC switch
(M156)	A/T device (Terminal No. 2)
(M156)	A/T device (Terminal No. 8)
(M156)	A/T device (Terminal No. 10)
(M159)	Door mirror remote control switch
(M160)	Front heated seat switch RH
(M161)	Front heated seat switch LH
(M163)	Clutch interlock cancel switch
(M207)	Console power socket

WKIA5039E

# GROUND CIRCUIT

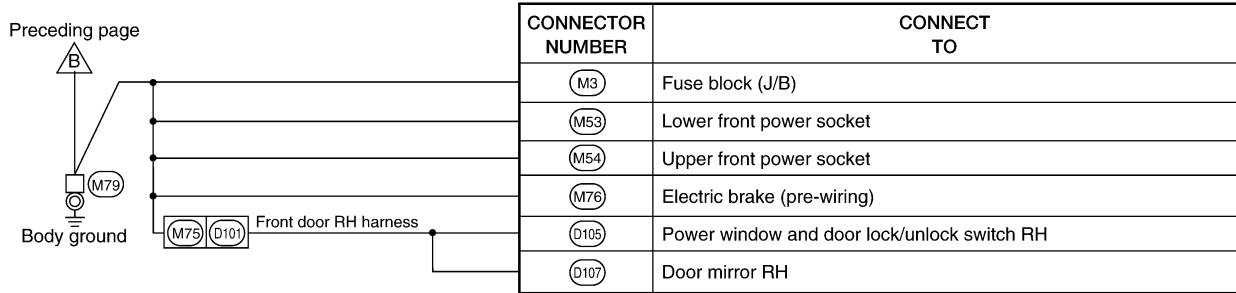
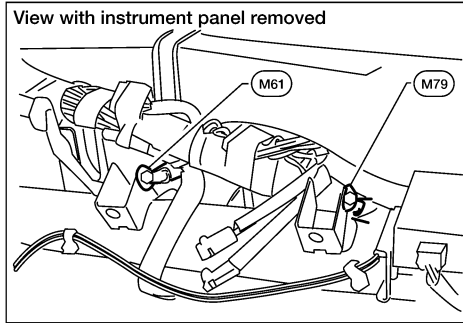

A  
B  
C  
D  
E  
F  
G  
H  
I  
J  
L  
M

PG

WKIA4098E

# GROUND CIRCUIT

## ENGINE ROOM HARNESS

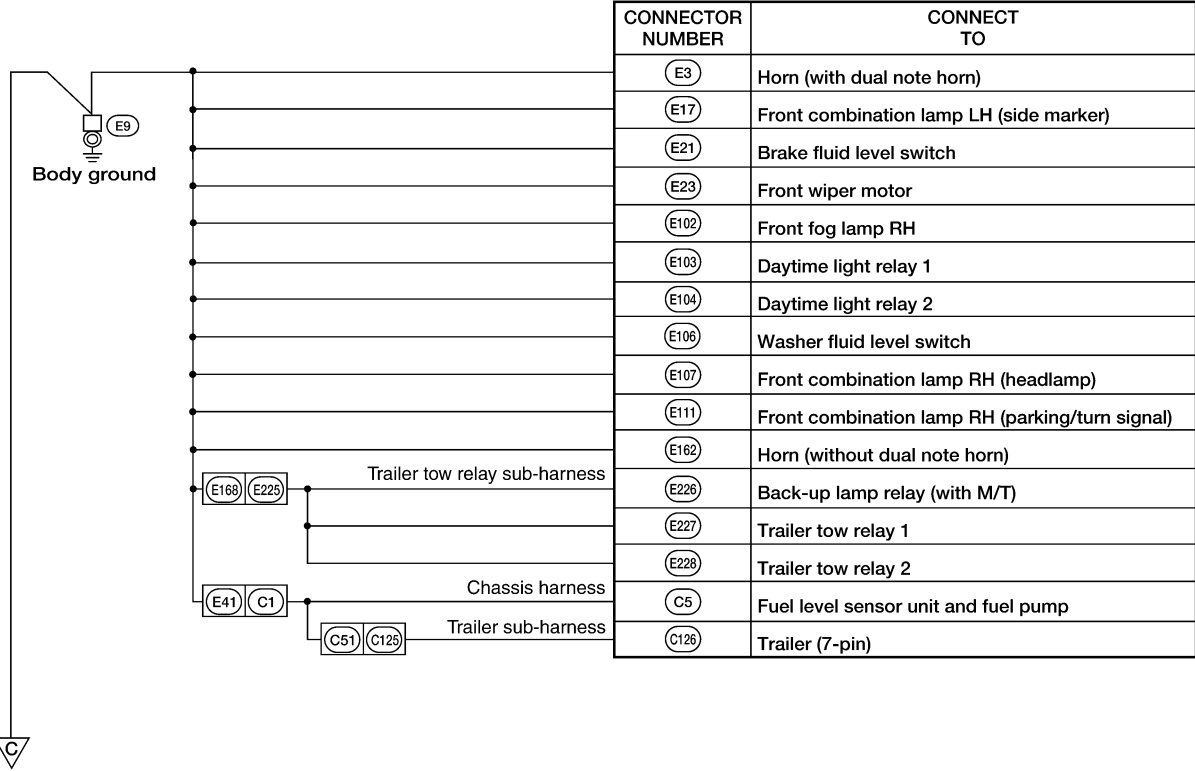
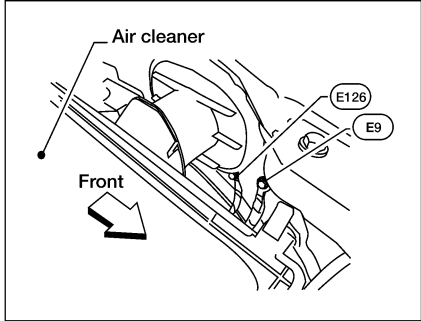

CONNECTOR NUMBER	CONNECT TO
(E3)	Horn (with dual note horn)
(E17)	Front combination lamp LH (side marker)
(E21)	Brake fluid level switch
(E23)	Front wiper motor
(E102)	Front fog lamp RH
(E103)	Daytime light relay 1
(E104)	Daytime light relay 2
(E106)	Washer fluid level switch
(E107)	Front combination lamp RH (headlamp)
(E111)	Front combination lamp RH (parking/turn signal)
(E162)	Horn (without dual note horn)
(E226)	Back-up lamp relay (with M/T)
(E227)	Trailer tow relay 1
(E228)	Trailer tow relay 2
(C5)	Fuel level sensor unit and fuel pump
(C126)	Trailer (7-pin)

Next page

WKIA5873E

# GROUND CIRCUIT

View with battery removed

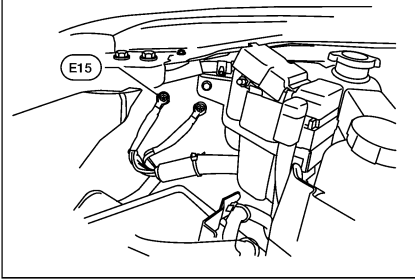

⬡ZV⬢ : WITH VQ40DE

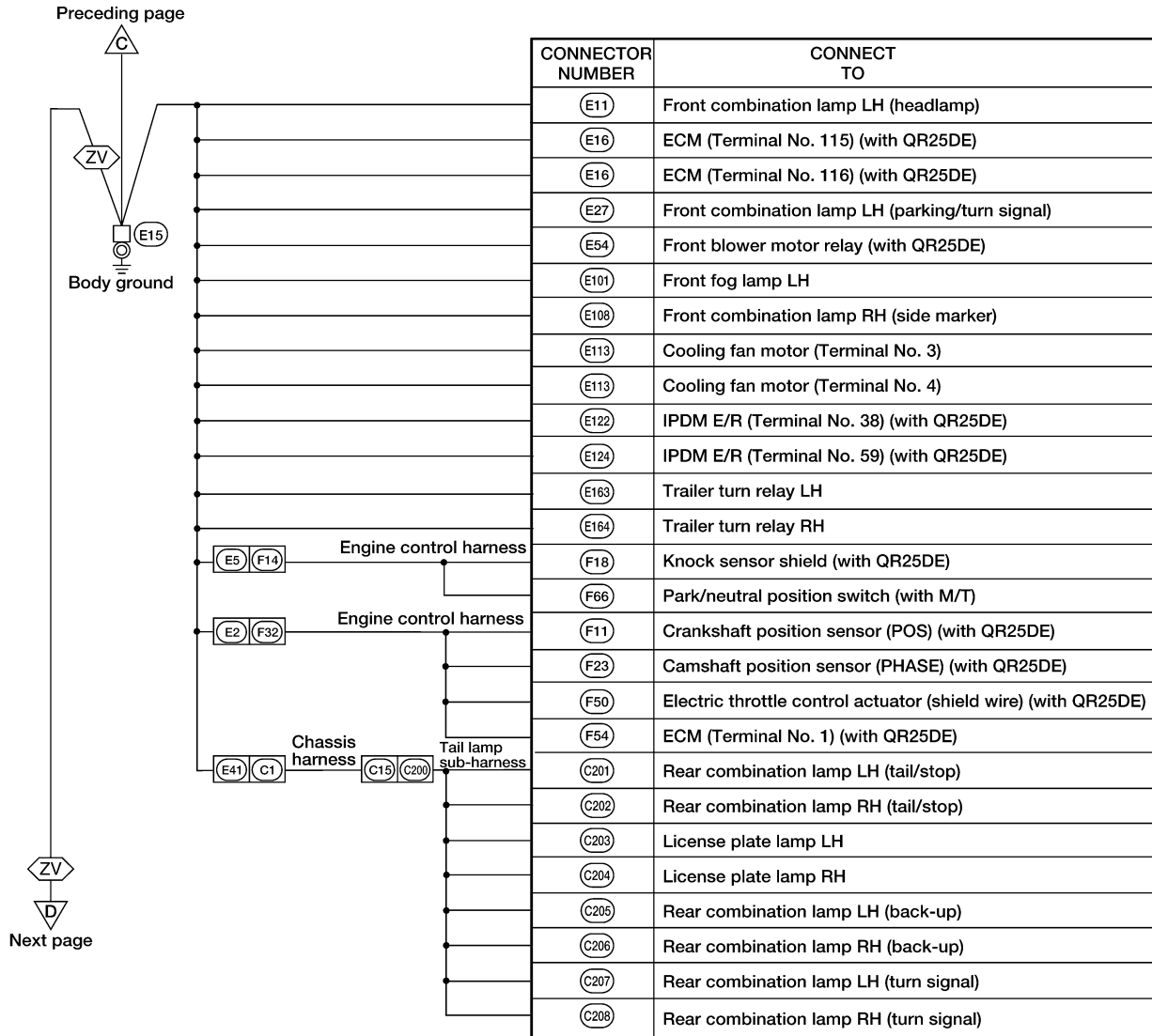

A  
B  
C  
D  
E  
F  
G  
H  
I  
J  
L  
M

PG

WKIA5041E

# GROUND CIRCUIT

View with battery removed

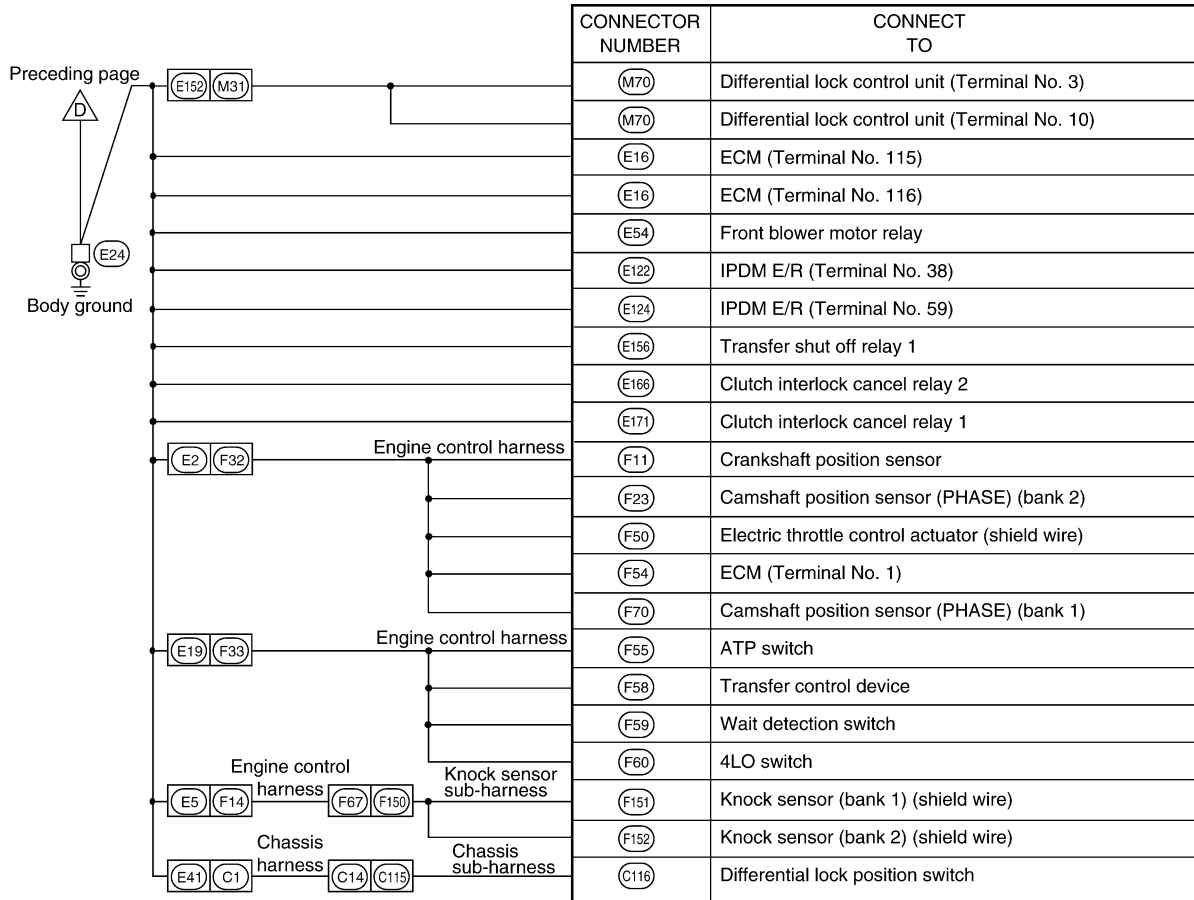
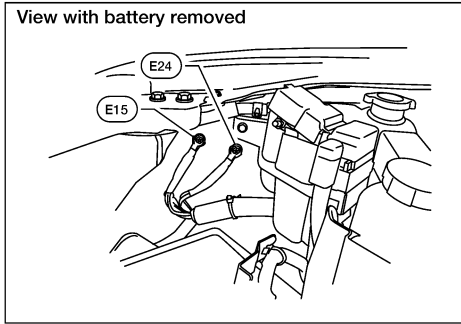

WKIA5874E

# GROUND CIRCUIT

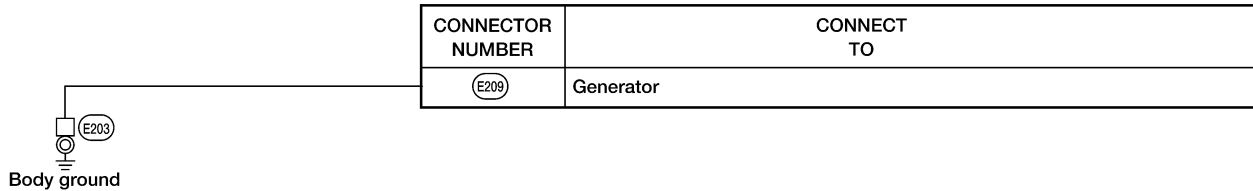
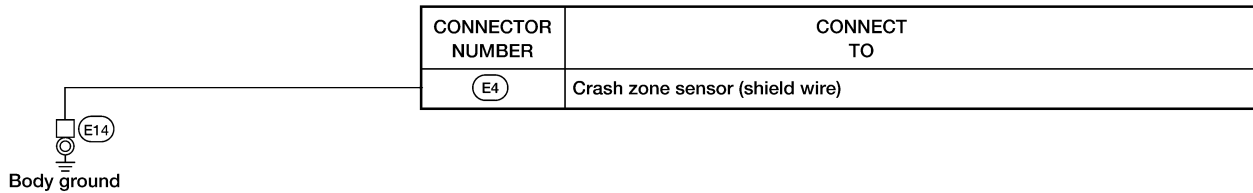
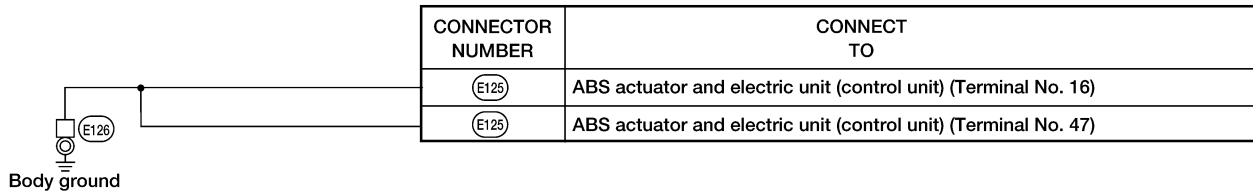
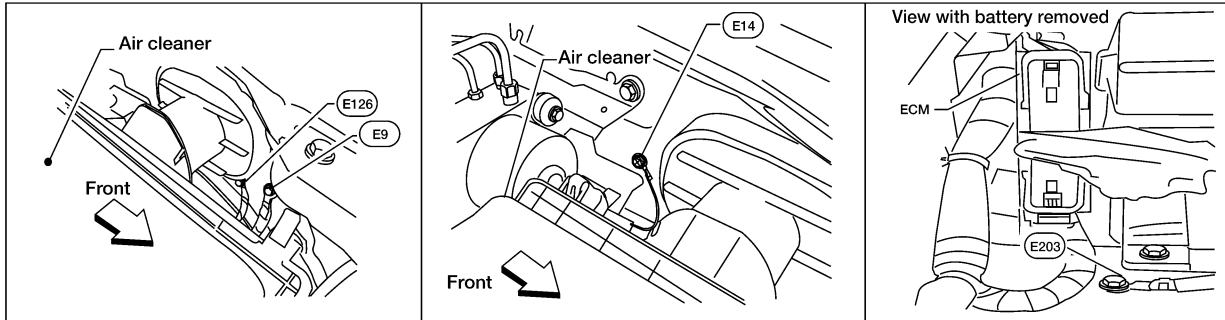

WKIA5875E

A  
B  
C  
D  
E  
F  
G  
H  
I  
J  
L  
M

PG

# GROUND CIRCUIT

## ENGINE CONTROL HARNESS (VQ40DE MODELS)

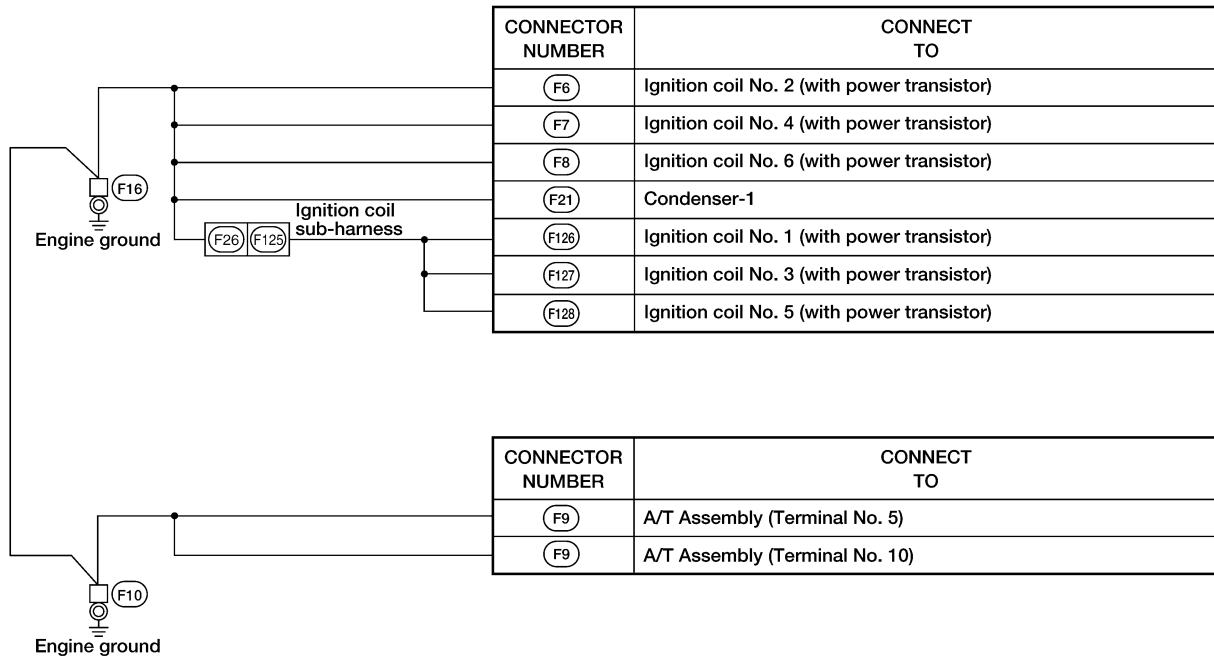
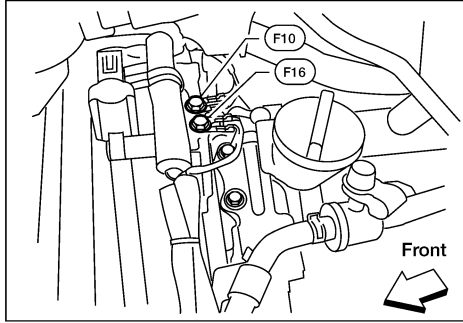

WKIA5876E



# GROUND CIRCUIT

## ENGINE CONTROL HARNESS (QR25DE MODELS)

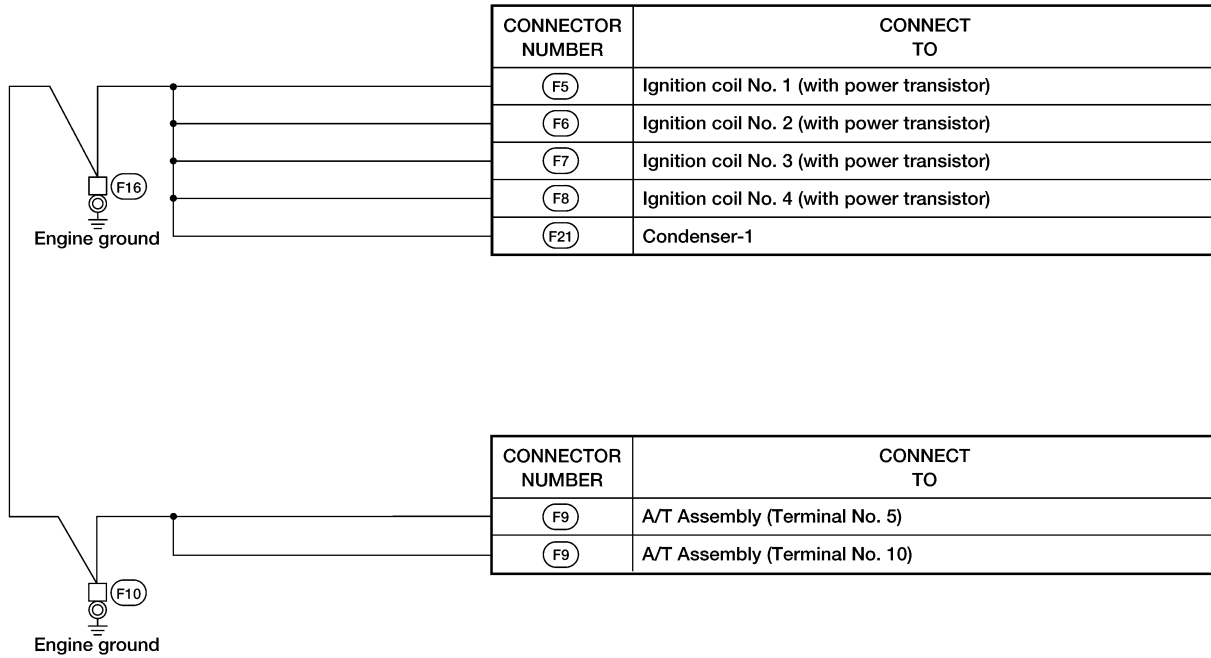
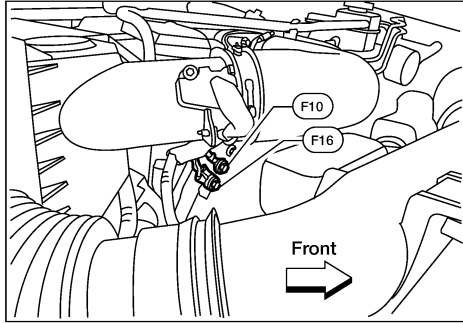

A  
B  
C  
D  
E  
F  
G  
H  
I  
J  
L  
M

PG

WKIA5877E

# GROUND CIRCUIT

## BODY HARNESS

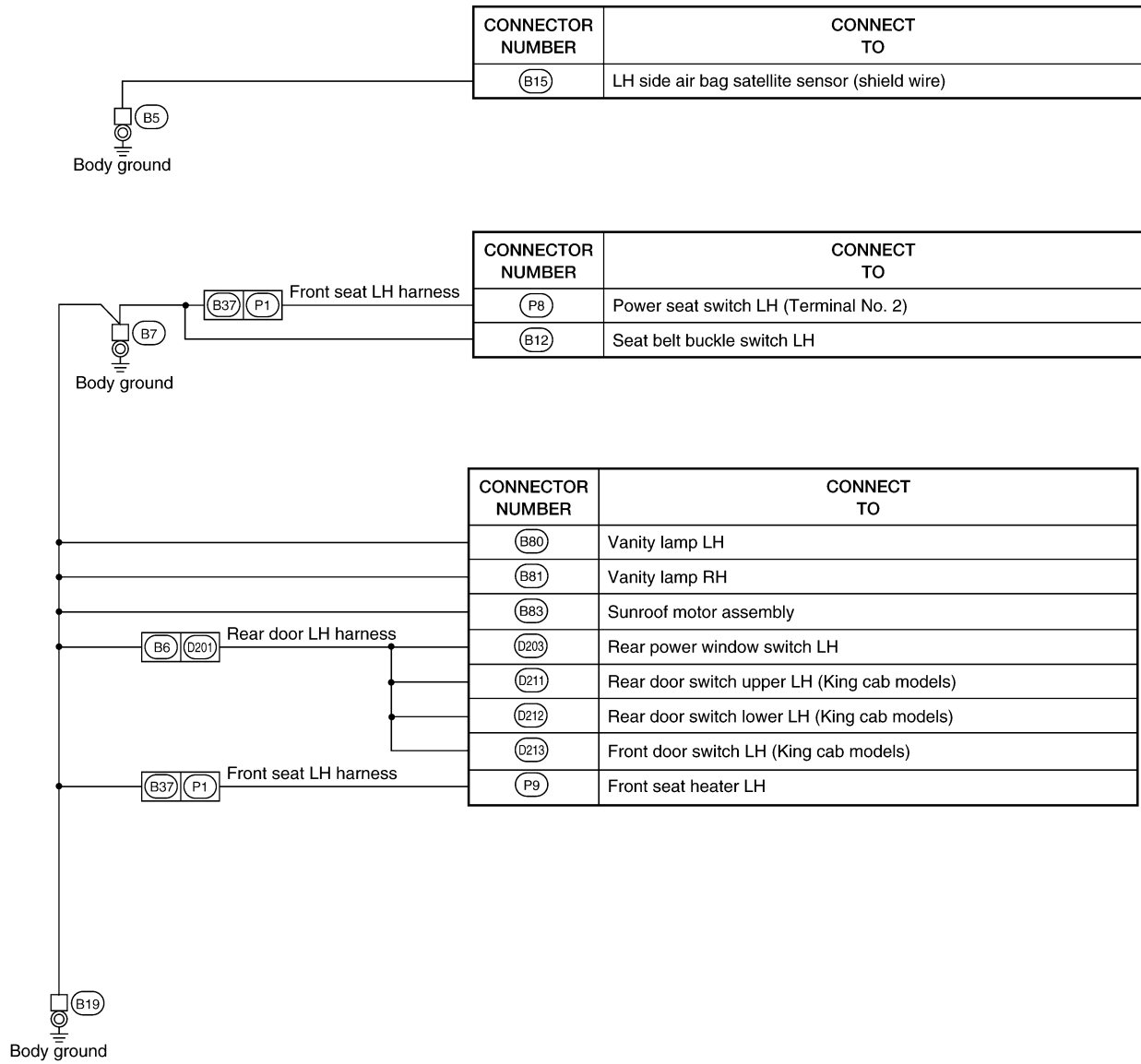
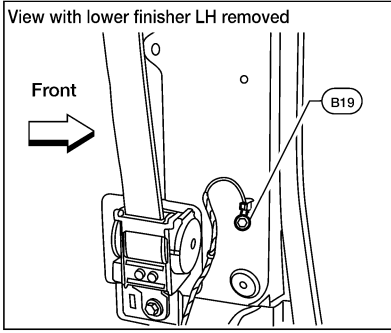
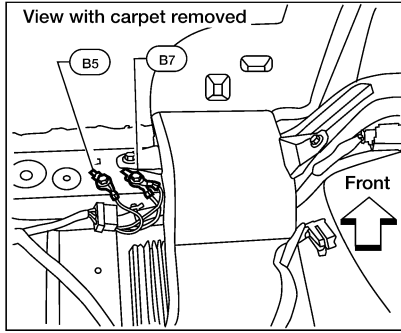

WKIA4057E

# GROUND CIRCUIT

## BODY NO. 2 HARNESS

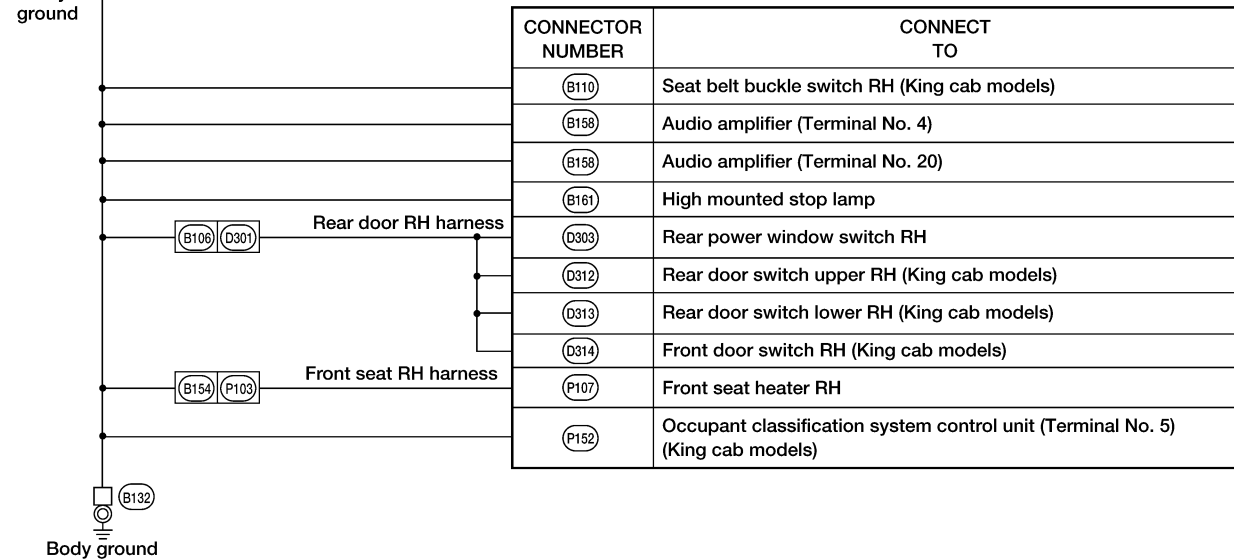
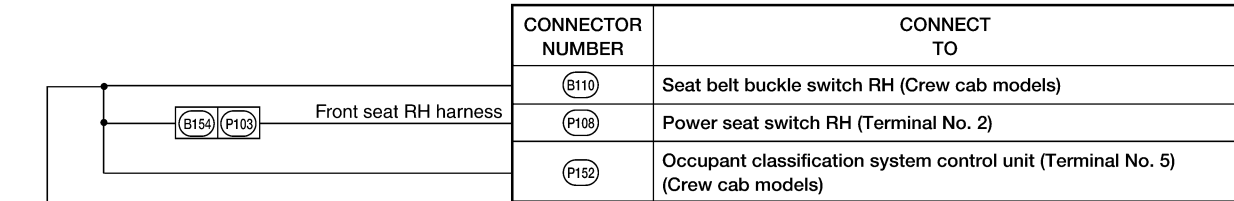
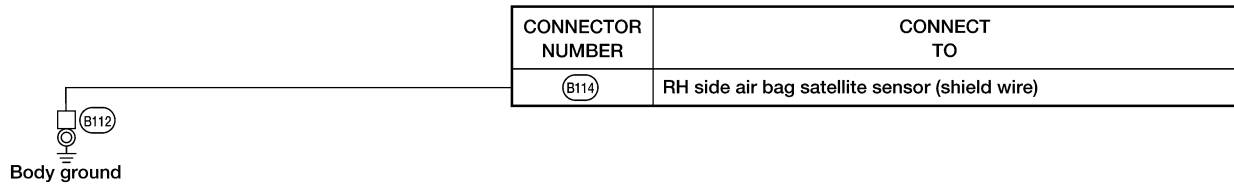
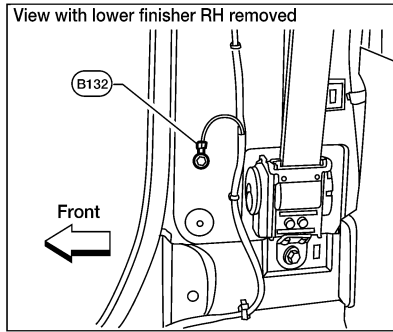
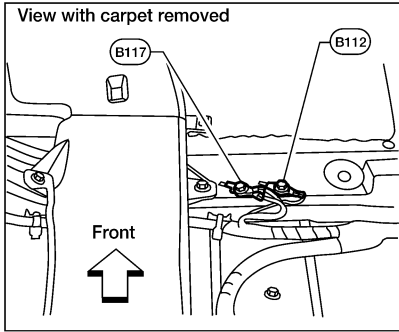

A  
B  
C  
D  
E  
F  
G  
H  
I  
J  
PG  
L  
M

WKIA4058E

## HARNESS

### Harness Layout

#### HOW TO READ HARNESS LAYOUT

EKS00EOS

The following Harness Layouts use a map style grid to help locate connectors on the drawings:

- Main Harness and Console Sub-harness
- Engine Room Harness (RH View) Engine Compartment, Generator Sub-harness and Trailer Tow Harness
- Engine Room Harness (Passenger Compartment)
- Engine Room Harness (LH View) Engine Compartment
- Engine Control Harness (QR25DE Models) and Injector Sub-harness
- Engine Control Harness (VQ40DE Models), Injector Sub-harness, Ignition Coil Sub-harness and Knock Sensor Sub-harness
- Chassis Harness, Differential Lock Sub-harness, Trailer Sub-harness and Tail Lamp Sub-harness
- Body Harness (King Cab Models)
- Body Harness (Crew Cab Models)
- Body No. 2 Harness (King Cab Models)
- Body No. 2 Harness (Crew Cab Models)
- Room Lamp Harness

#### To use the grid reference

1. Find the desired connector number on the connector list.
2. Find the grid reference.
3. On the drawing, find the crossing of the grid reference letter column and number row.
4. Find the connector number in the crossing zone.
5. Follow the line to the connector.

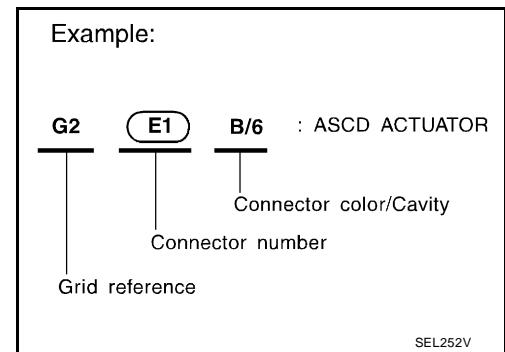

# HARNESS

## OUTLINE (KING CAB MODELS)

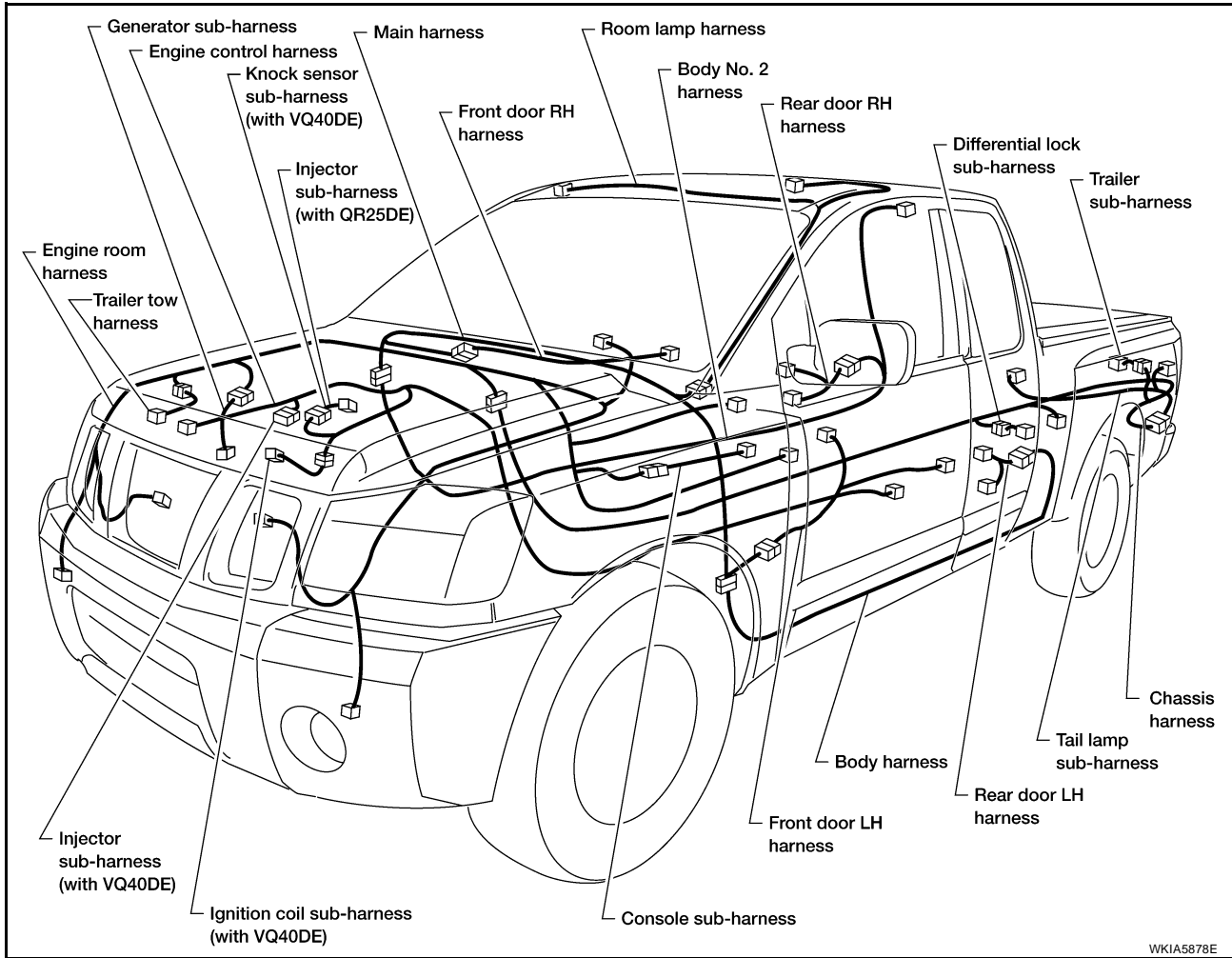

A  
B  
C  
D  
E  
F  
G  
H  
I  
J

PG

L  
M

# HARNESS

## OUTLINE (CREW CAB MODELS)

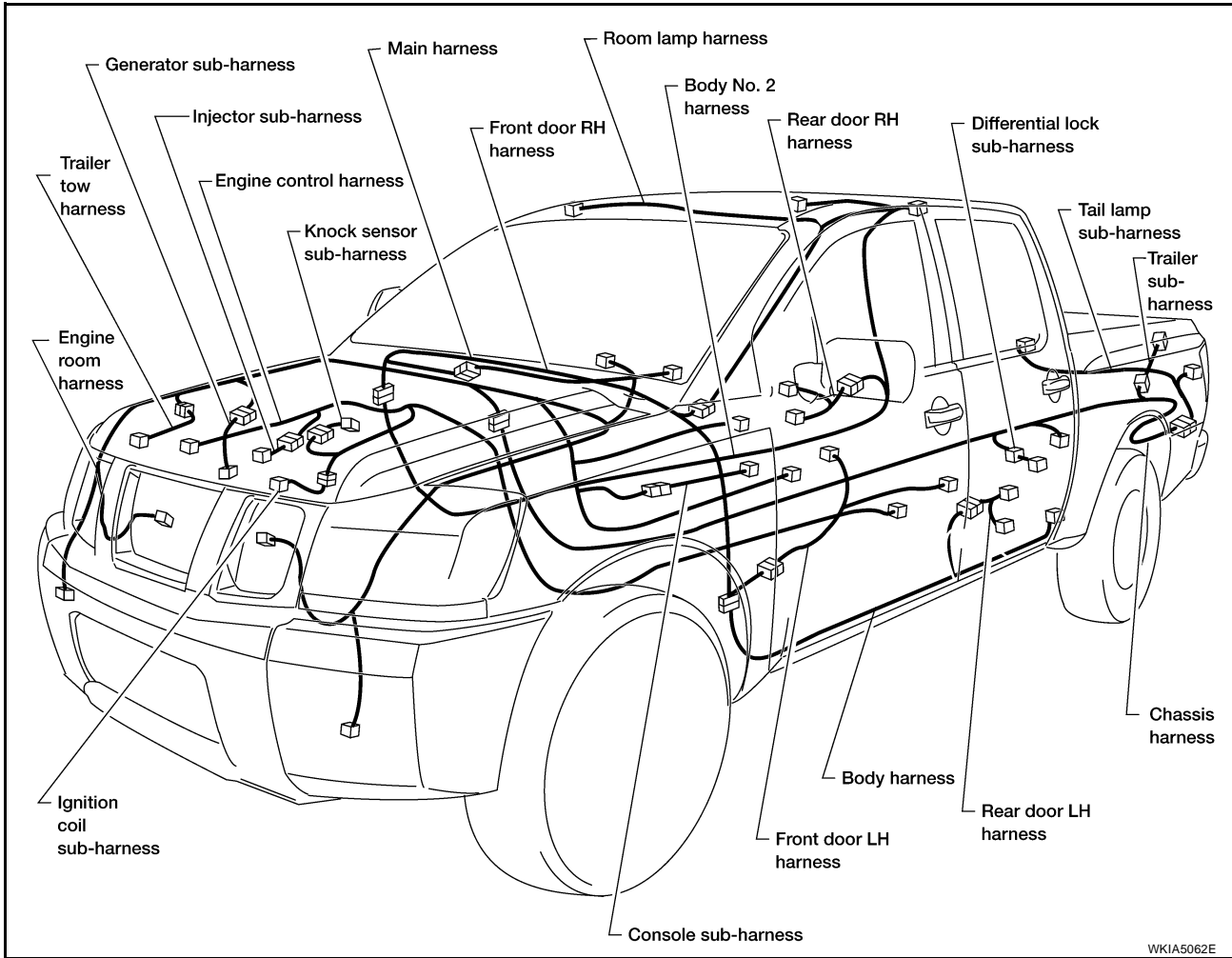

# HARNESS

## MAIN HARNESS

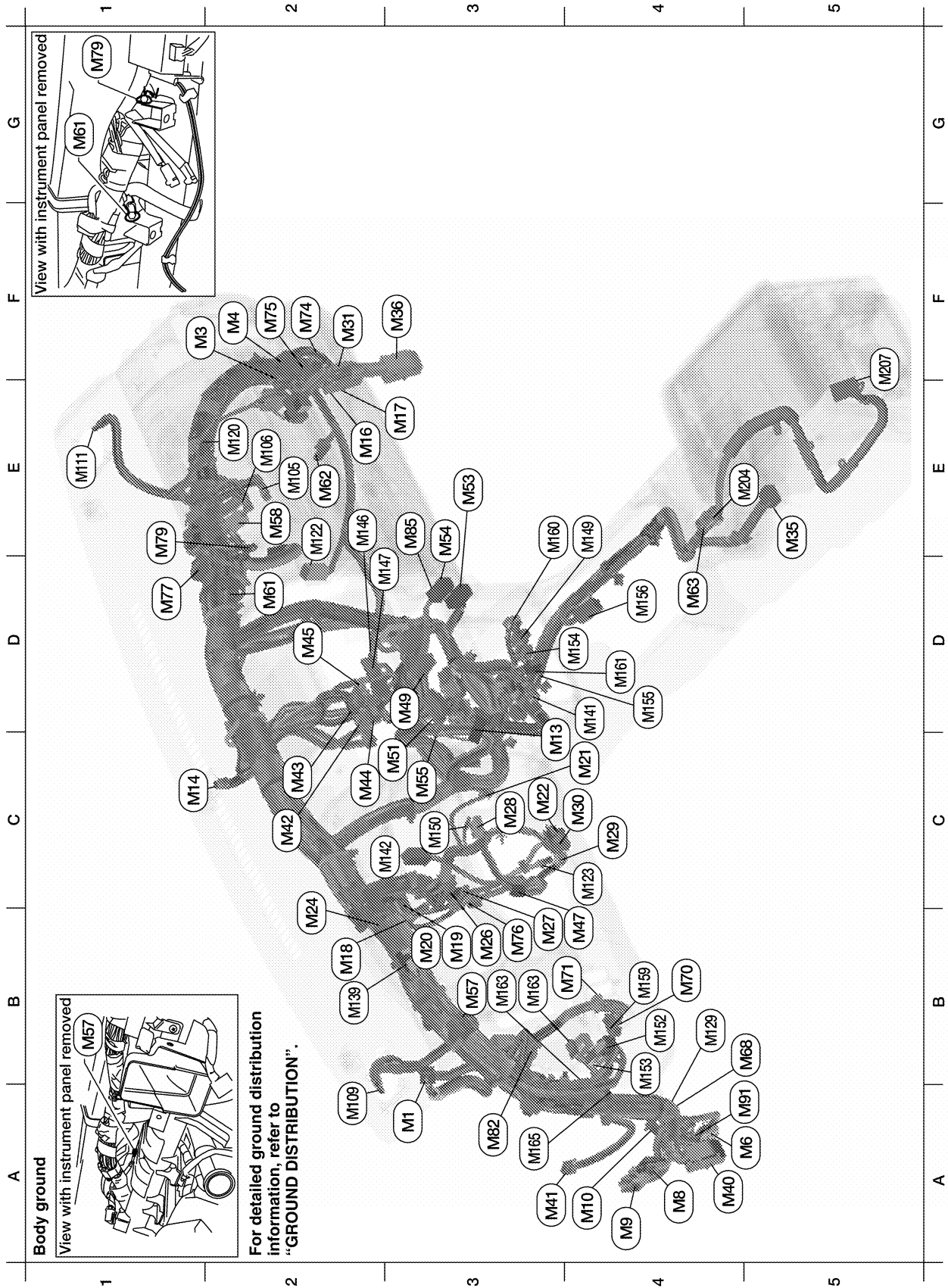

A  
B  
C  
D  
E  
F  
G  
H  
I  
J  
L  
M  
PG

# HARNESS

A3	M1	W/12	: To R1	B5	M68	V/1	: To M250 (with XM satellite radio tuner)
F1	M3	W/8	: Fuse block (J/B)	B5	M68	BR/1	: To M250 (with Sirius satellite radio tuner)
F2	M4	W/16	: Fuse block (J/B)	B4	M70	W/26	: Differential lock control unit
A5	M6	W/6	: To E10	B4	M71	W/6	: Cargo lamp switch
A4	M8	W/16	: To D2	F2	M74	W/16	: To D201
A4	M9	W/24	: To D1	F2	M75	W/12	: To D101
A4	M10	Y/4	: To E29	B3	M76	W/6	: Electric brake (pre-wiring)
C3	M13	W/3	: Front passenger air bag OFF indicator	D1	M77	Y/4	: Front passenger air bag module (service replacement)
C1	M14	B/4	: Optical sensor	E1	M79	—	: Body ground
E2	M16	W/12	: To B162	A3	M82	W/2	: Circuit breaker-2
E3	M17	W/16	: To B163	E3	M85	W/4	: Aux in jack
B2	M18	W/40	: BCM (body control module)	A4	M91	W/16	: To E26
B3	M19	W/15	: BCM (body control module)	E2	M105	Y/2	: Front passenger air bag module
B3	M20	B/15	: BCM (body control module)	E2	M106	O/2	: Front passenger air bag module
C4	M21	W/4	: NATS antenna amp.	A2	M109	BR/2	: Front tweeter LH
C3	M22	W/16	: Data link connector	E1	M111	BR/2	: Front tweeter RH
B2	M24	W/40	: Combination meter	E2	M120	W/4	: Remote keyless entry receiver
B3	M26	W/6	: Ignition switch	E2	M122	B/4	: Front blower motor resistor
B3	M27	W/2	: Key switch	C4	M123	W/2	: Tire pressure warning check connector
C3	M28	W/16	: Combination switch	B4	M129	V/1	: Satellite radio tuner (with XM satellite radio tuner)
C4	M29	Y/6	: Combination switch (spiral cable)	B4	M129	BR/1	: Satellite radio tuner (with Sirius satellite radio tuner)
C4	M30	GR/8	: Combination switch (spiral cable)	D4	M141	GR/8	: 4WD shift switch
F2	M31	SMJ	: To E152	C3	M142	B/6	: Mode door motor
E5	M35	Y/28	: Air bag diagnosis sensor unit	E2	M146	W/2	: Intake sensor
F3	M36	SMJ	: To B149	D2	M147	B/6	: Air mix door motor front
A4	M40	SMJ	: To B69	E4	M149	W/6	: Differential lock mode switch
A3	M41	W/16	: Pre-wiring for satellite radio tuner	C3	M150	W/2	: Ignition keyhole illumination
A3	M41	W/16	: Satellite radio tuner	B4	M152	W/26	: Transfer case control unit
C2	M42	W/12	: Audio unit	B4	M153	W/24	: Transfer case control unit
C2	M43	W/10	: Audio unit	D4	M154	GR/6	: VDC off switch
C2	M44	W/6	: Audio unit	D4	M155	W/8	: HDC switch
D2	M45	W/16	: Audio unit	D4	M156	W/10	: A/T device
B4	M47	W/8	: Steering angle sensor	B4	M159	W/16	: Door mirror remote control switch
D3	M49	B/26	: Front air control	E3	M160	BR/6	: Front heated seat switch RH
C3	M51	W/8	: Front blower switch	D4	M161	W/6	: Front heated seat switch LH
E3	M53	B/2	: Lower front power socket	B3	M163	W/8	: Clutch interlock cancel switch (with M/T)
E3	M54	GR/2	: Upper front power socket	A3	M165	L/4	: Cargo lamp relay
C3	M55	W/4	: Hazard switch	Console sub-harness			
B3	M57	—	: Body ground	E5	M204	W/6	: To M63
E2	M58	B6	: Intake door motor	F5	M207	B/2	: Console power socket
D2	M61	—	: Body ground				
E2	M62	B/2	: Front blower motor				
D4	M63	W/6	: To M204				



# HARNESS

## ENGINE ROOM HARNESS (RH VIEW)

### Engine Compartment

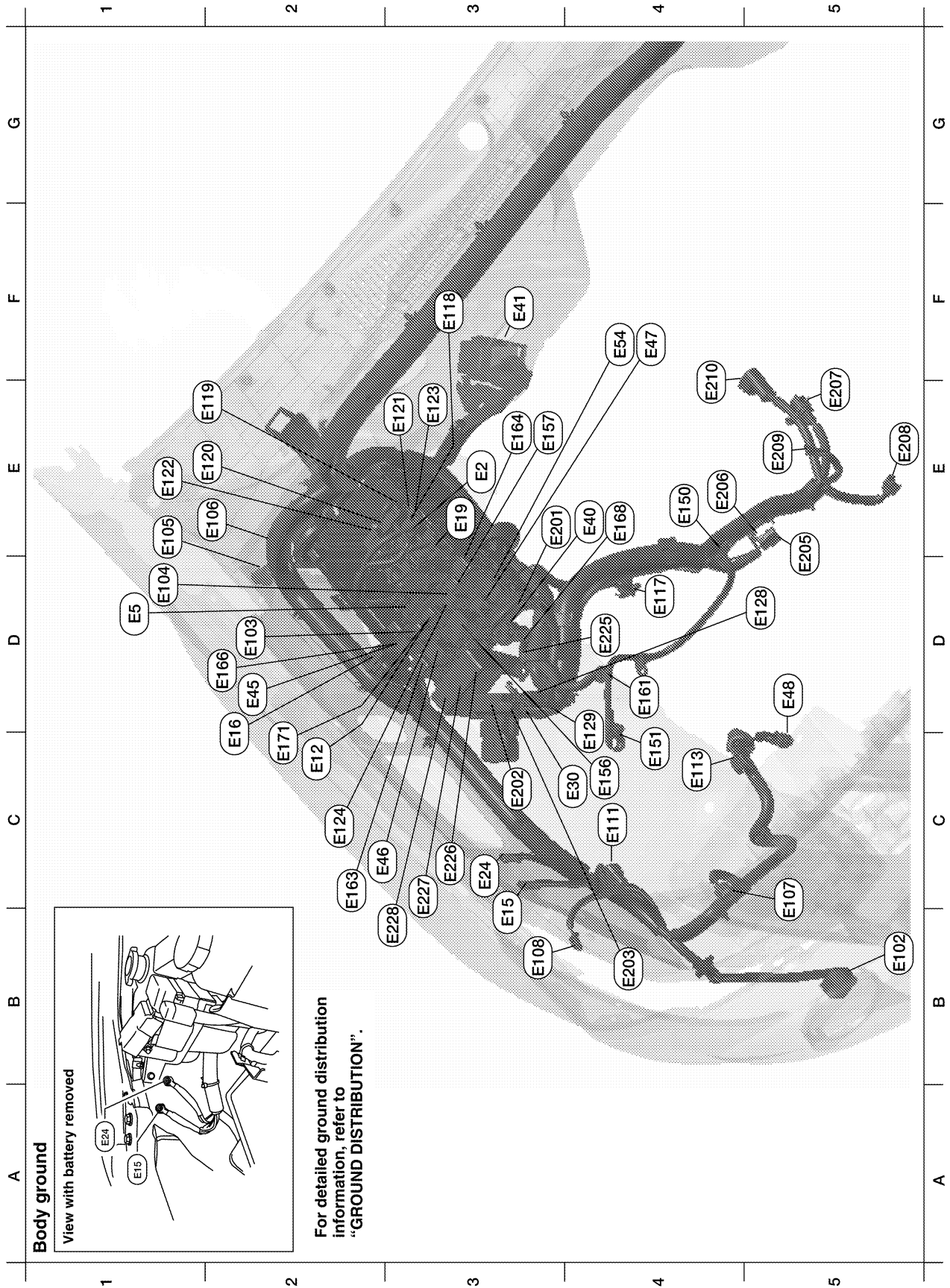

Refer to [PG-53, "ENGINE ROOM HARNESS \(LH VIEW\)"](#) for continuation of engine room harness.

# HARNESSES

E3	E2	W/16	: To F32	C4	E156	L/4	: Transfer shut off relay 1
D1	E5	W/24	: To F14	E3	E157	L/4	: Transfer shut off relay 2
C2	E12	L/5	: Stop lamp relay	C3	E161	B/3	: Battery current sensor
B3	E15	—	: Body ground	C2	E163	L/4	: Trailer turn relay LH
D2	E16	B/40	: ECM	E3	E164	L/4	: Trailer turn relay RH
E4	E19	W/16	: To F33	D2	E166	BR/6	: Clutch interlock cancel relay 2 (with M/T)
C3	E24	—	: Body ground	E4	E168	W/12	: To E225
C3	E30	—	: Fusible link box (battery)	C2	E171	B/5	: Clutch interlock cancel relay 1
E4	E40	GR/9	: To E201	Generator sub-harness			
F3	E41	SMJ	: To C1 (located RH rear of engine compartment)	E3	E201	GR/9	: To E40
C2	E45	BR/6	: Back-up lamp relay (with A/T)	C3	E202	B/1	: To fuse and fusible link box
C3	E46	B/5	: Transfer shift high relay	B4	E203	—	: Body ground
F4	E47	B/5	: Transfer shift low relay	E6	E205	B/3	: Generator
D5	E48	B/3	: Refrigerant pressure sensor	E4	E206	B/1	: Generator
F4	E54	BR/6	: Front blower motor relay	F5	E207	GR/1	: Starter motor
B5	E102	B/2	: Front fog lamp RH	E4	E208	GR/1	: Oil pressure switch (with VQ40DE)
C2	E103	B/5	: Daytime light relay 1	E5	E209	B/1	: Generator
D1	E104	L/4	: Daytime light relay 2	E4	E210	B/1	: Starter motor
E1	E105	B/2	: Washer motor	Trailer tow harness			
E2	E106	BR/2	: Washer fluid level switch	D4	E225	W/12	: To E168
C5	E107	B/3	: Front combination lamp RH (head lamp)	C3	E226	L/6	: Back-up lamp relay (with M/T)
B3	E108	GR/2	: Front combination lamp RH (side marker)	C3	E227	L/4	: Trailer tow relay 1
C4	E111	GR/3	: Front combination lamp RH (parking/turn signal)	B3	E228	BR/6	: Trailer tow relay 2
C4	E113	GR/4	: Cooling fan motor				
D4	E117	GR/2	: Front wheel sensor RH				
F2	E118	B/2	: IPDM E/R (intelligent power distribution module engine room)				
E1	E119	W/16	: IPDM E/R (intelligent power distribution module engine room)				
E1	E120	W/6	: IPDM E/R (intelligent power distribution module engine room)				
E3	E121	BR/12	: IPDM E/R (intelligent power distribution module engine room)				
E1	E122	W/12	: IPDM E/R (intelligent power distribution module engine room)				
E3	E123	BR/8	: IPDM E/R (intelligent power distribution module engine room)				
C2	E124	B/6	: IPDM E/R (intelligent power distribution module engine room)				
D5	E128	GR/2	: Fusible link box (battery)				
D4	E129	BR/2	: Fusible link box (battery)				
E4	E150	—	: Battery ground				
C4	E151	—	: Negative battery cable				

# HARNESS

## Passenger Compartment

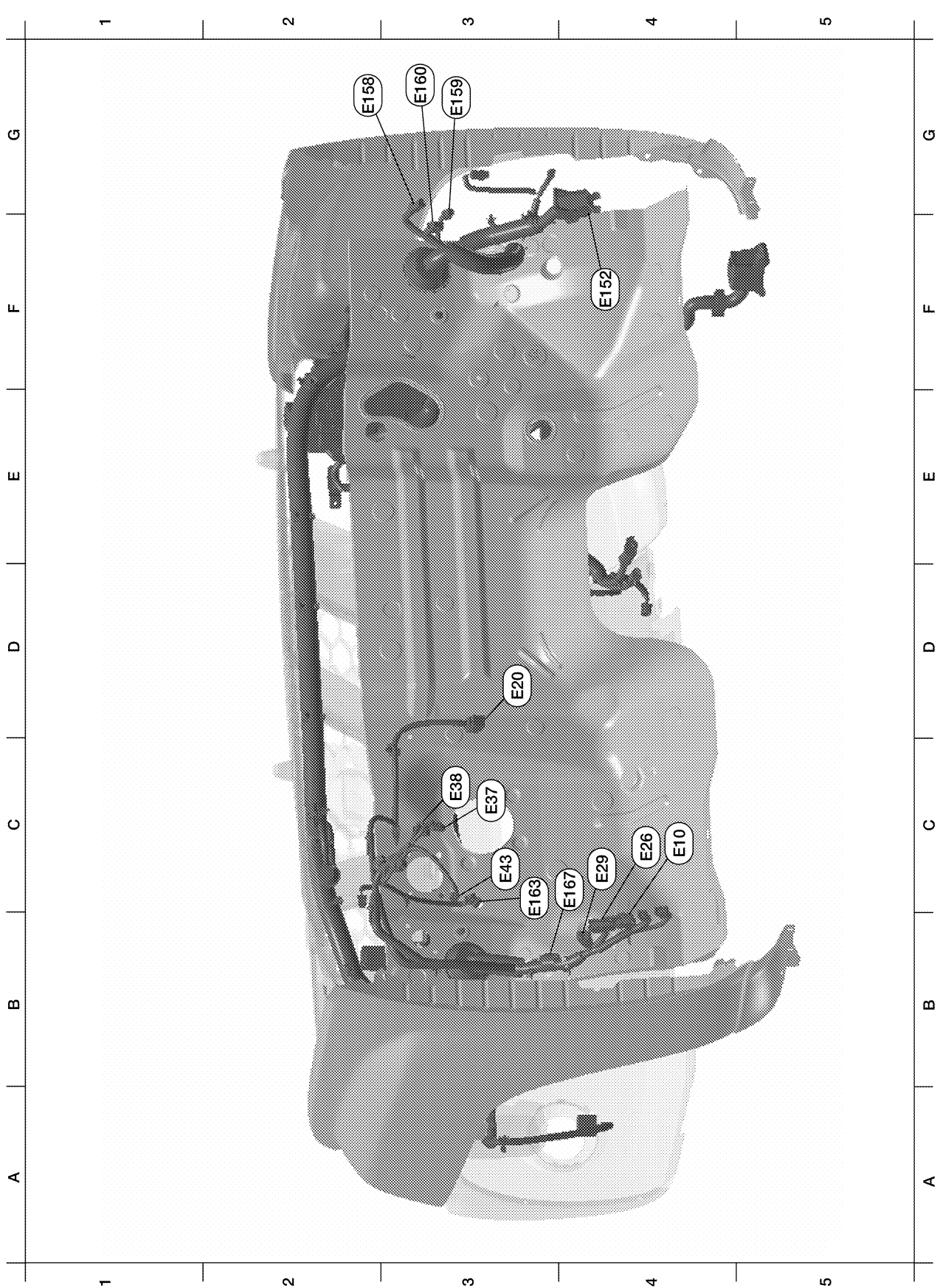

LKIA0840E

# HARNESS

C4	E10	W/8	: To M6	C3	E43	L/2	: ASCD clutch switch
D3	E20	B/6	: Accelerator pedal position (APP) sensor	F4	E152	SMJ	: To M31
C4	E26	W/16	: To M91	G2	E158	B/1	: Fuse block (J/B)
C4	E29	Y/4	: To M10	G3	E159	B/2	: Fuse block (J/B)
C3	E37	BR/2	: ASCD brake switch	G3	E160	W/1	: Fuse block (J/B)
C3	E38	W/4	: Stop lamp switch (with A/T)	C3	E163	L/2	: Clutch interlock switch
C3	E38	B/2	: Stop lamp switch (with M/T)	C4	E167	B/2	: Diode-3

# HARNESS

## ENGINE ROOM HARNESS (LH VIEW)

### Engine Compartment

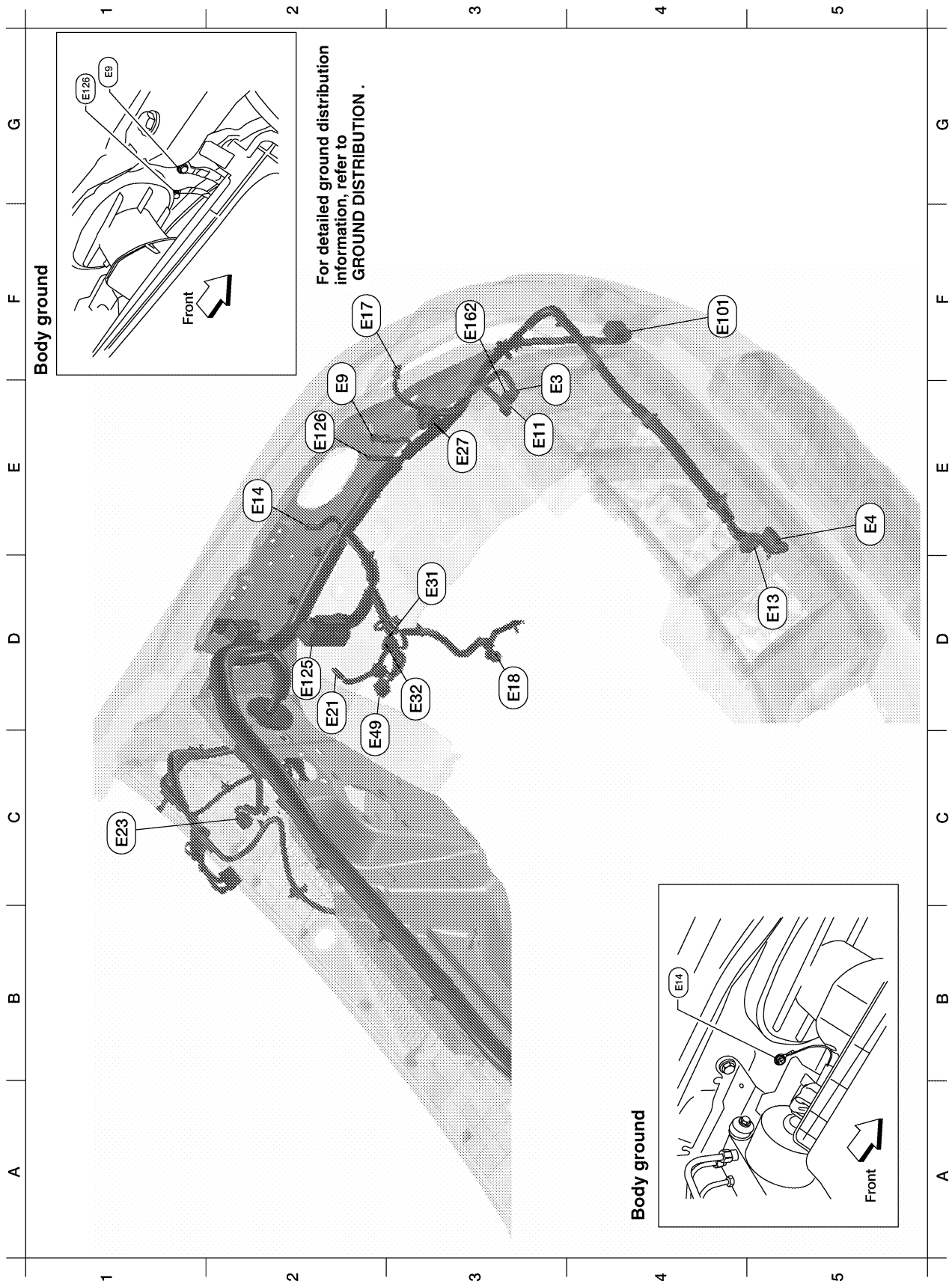

A  
B  
C  
D  
E  
F  
G  
H  
I  
J  
K  
L  
M

PG

Refer to [PG-49, "ENGINE ROOM HARNESS \(RH VIEW\)"](#) for continuation of engine room harness.

LKIA0841E

# HARNESS

E3	E3	B/1	: Horn	C1	E23	GR/5	: Front wiper motor
E5	E4	Y/2	: Crash zone sensor	E3	E27	GR/3	: Front combination lamp LH (parking/turn signal)
F2	E9	—	: Body ground	D3	E31	B/3	: Front pressure sensor
E3	E11	B/3	: Front combination lamp LH (headlamp)	D3	E32	B/3	: Rear pressure sensor
D5	E13	GR/2	: Ambient sensor 2	C2	E49	B/6	: Active booster
E2	E14	—	: Body ground	F4	E101	B/2	: Front fog lamp LH
F2	E17	GR/2	: Front combination lamp LH (side marker)	D2	E125	B/47	: ABS actuator and electric unit (control unit)
D3	E18	GR/2	: Front wheel sensor LH	E2	E126	—	: Body ground
D2	E21	GR/2	: Brake fluid level switch	F3	E162	B/1	: Horn

# HARNESS

## ENGINE CONTROL HARNESS (QR25DE MODELS)

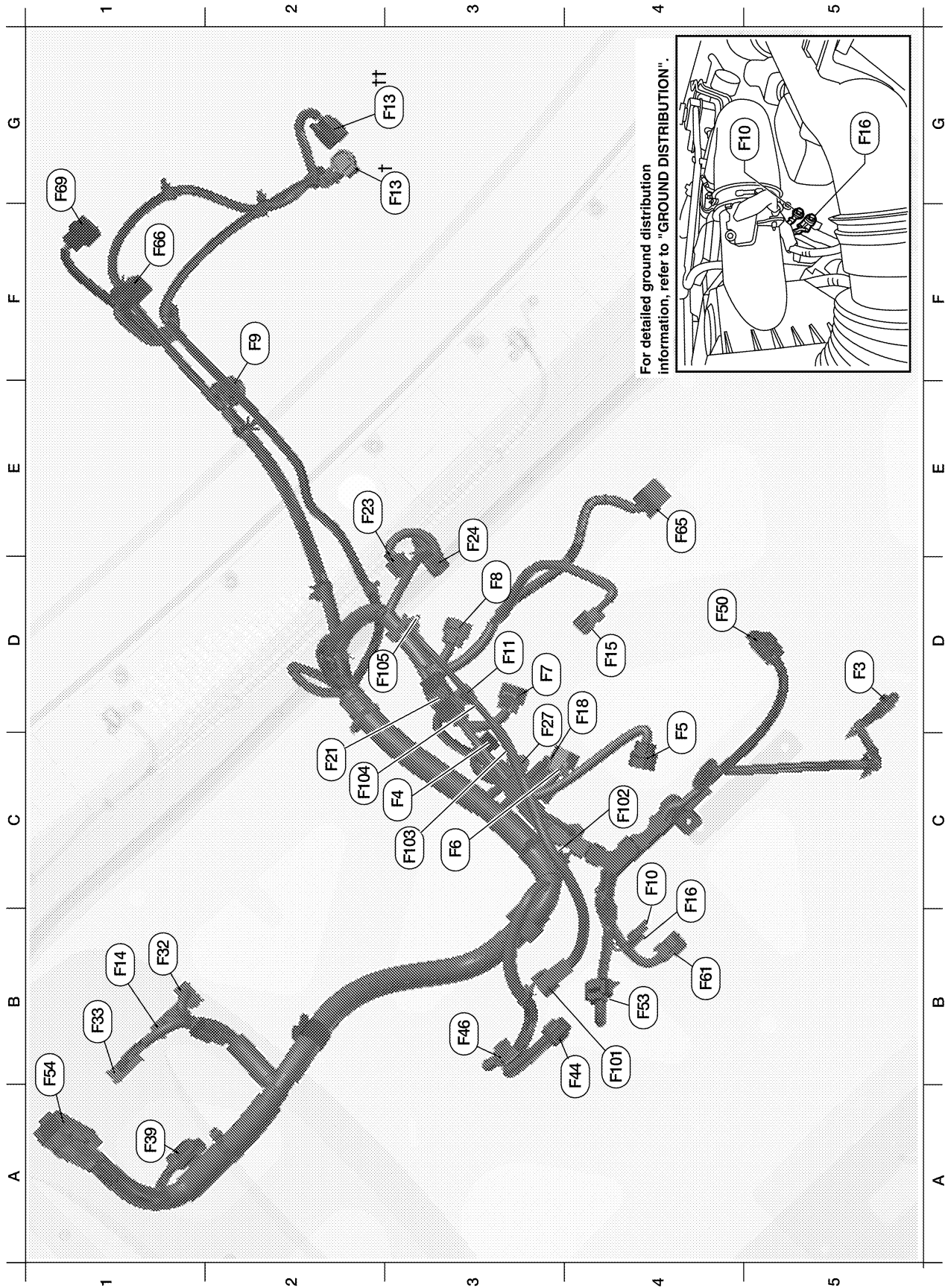

LKIA0842E

A  
B  
C  
D  
E  
F  
G  
H  
I  
J  
K  
L  
M

PG

# HARNESS

D5	F3	B/1	: A/C Compressor	B1	F32	W/16	: To E2
C3	F4	GR/1	: Oil pressure switch	B1	F33	GR/6	: To E19
C4	F5	B/6	: Ignition coil No. 1 (with power transistor)	A1	F39	—	: Fusible link box (battery)
C3	F6	GR/3	: Ignition coil No. 2 (with power transistor)	B4	F44	B/6	: To F101
D3	F7	GR/3	: Ignition coil No. 3 (with power transistor)	B3	F46	B/2	: Power steering pressure sensor
D3	F8	GR/3	: Ignition coil No. 4 (with power transistor)	D4	F50	GR/2	: Electric throttle control actuator
F2	F9	G/10	: A/T assembly	B4	F53	B/6	: Mass air flow sensor
C4	F10	—	: Engine ground	B1	F54	B/81	: ECM
D3	F11	B/3	: Crankshaft position sensor (POS)	B4	F61	G/2	: Intake valve timing control solenoid valve
G3	F13†	G/4	: Heated oxygen sensor 2 (with A/T)	E4	F65	L/4	: Air fuel ratio (A/F) sensor
G3	F13††	L/4	: Heated oxygen sensor 2 (with M/T)	F1	F66	B/2	: Park/neutral position switch (with M/T)
B1	F14	W/24	: To E5	G1	F69	W/2	: Back-up lamp switch (with M/T)
D4	F15	L/2	: EVAP canister purge volume control solenoid valve	Injector sub-harness			
C4	F16	—	: Engine ground	B4	F101	B/6	: To F44
D4	F18	C3	: Knock sensor	C4	F102	GR/2	: Fuel injector No. 1
C2	F21	GR/2	: Condenser-1	C3	F103	GR/2	: Fuel injector No. 2
E2	F23	B/3	: Camshaft position sensor (PHASE)	C2	F104	GR/2	: Fuel injector No. 3
E3	F24	GR/2	: Engine coolant temperature sensor	D2	F105	GR/2	: Fuel injector No. 4
C3	F27	B/1	: Starter motor				



# HARNESS

## ENGINE CONTROL HARNESS (VQ40DE MODELS)

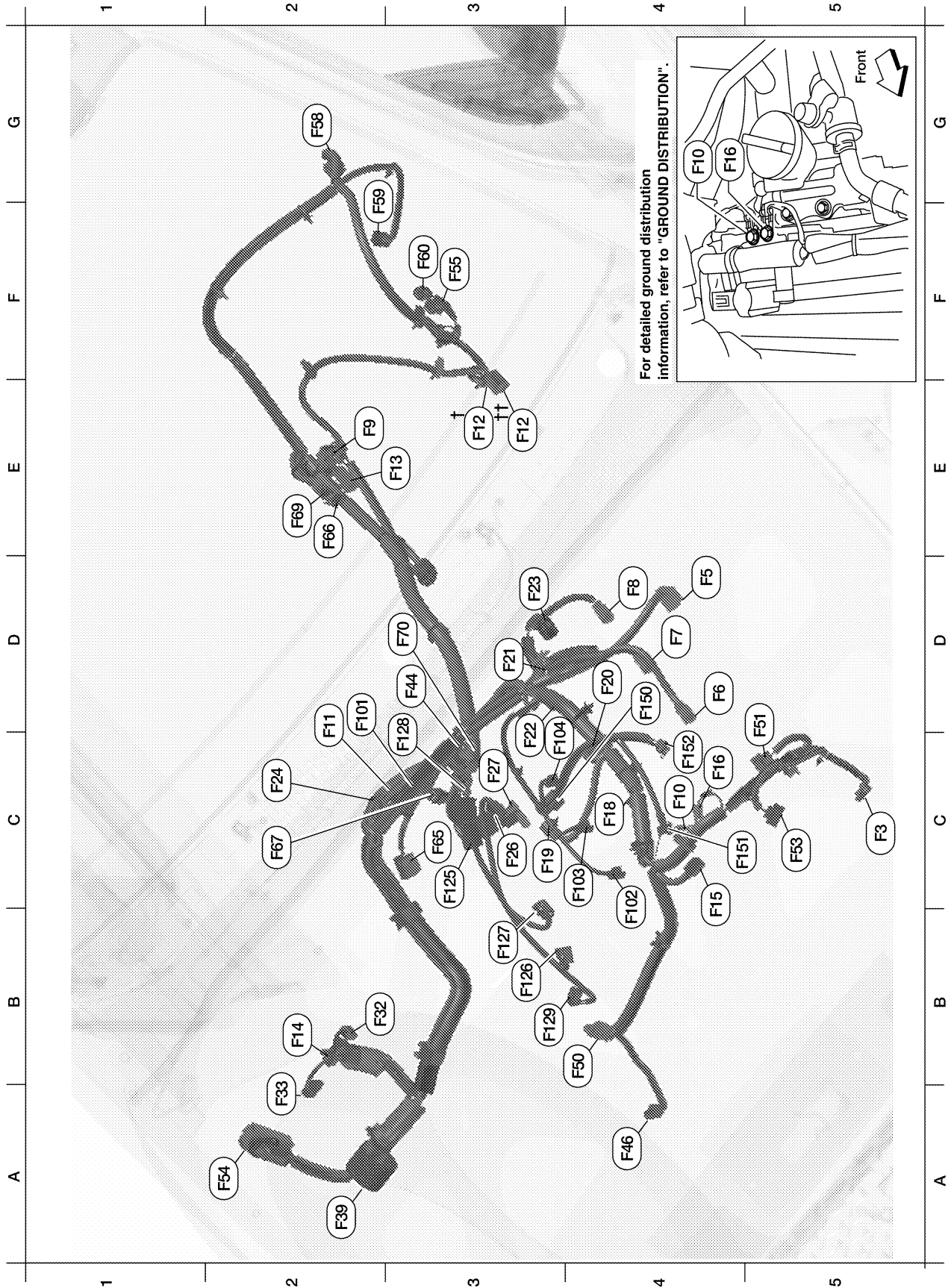

LKIA0843E

A  
B  
C  
D  
E  
F  
G  
H  
I  
J  
K  
L  
M

PG

# HARNESS

C5	F3	B/1	: A/C Compressor	B4	F50	B/6	: Electric throttle control actuator
D4	F5	GR/4	: Air fuel ratio (A/F) sensor 1 (bank 2)	D5	F51	G/2	: Intake valve timing control solenoid valve (bank 2)
D4	F6	GR/3	: Ignition coil No. 2 (with power transistor)	C5	F53	B/6	: Mass air flow sensor
D4	F7	GR/3	: Ignition coil No. 4 (with power transistor)	A2	F54	B/81	: ECM
D4	F8	GR/3	: Ignition coil No. 6 (with power transistor)	F3	F55	B/2	: ATP switch
E2	F9	G/10	: A/T assembly	G2	F58	B/8	: Transfer control device
C4	F10	—	: Engine ground	F2	F59	GR/2	: Wait detection switch
D2	F11	B/3	: Crankshaft position sensor (POS)	F3	F60	GR/2	: 4LO switch
E3	F12†	G/4	: Heated oxygen sensor 2 (bank 2) (with A/T)	C3	F65	GR/4	: Air fuel ratio (A/F) sensor 1 (bank 1)
E3	F12††	G/4	: Heated oxygen sensor 2 (bank 2) (with M/T)	E2	F66	B/2	: Park/neutral position switch (with M/T)
E3	F13	L/4	: Heated oxygen sensor 2 (bank 1)	C2	F67	L/4	: To F150
B2	F14	W/24	: To E5	E2	F69	W/2	: Back-up lamp switch (with M/T)
B4	F15	L/2	: EVAP canister purge volume control solenoid valve	D3	F70	GR/3	: Camshaft position sensor (PHASE) (bank 1)
C4	F16	—	: Engine ground	Injector sub-harness			
C4	F18	GR/2	: Fuel injector No. 2	D2	F101	GR/4	: To F44
C3	F19	B/2	: VIAS control solenoid valve	B4	F102	GR/2	: Fuel injector No. 1
C4	F20	GR/2	: Fuel injector No. 4	B4	F103	GR/2	: Fuel injector No. 3
D3	F21	GR/2	: Condenser-1	C3	F104	GR/2	: Fuel injector No. 5
C3	F22	GR/2	: Fuel injector No. 6	Ignition coil sub-harness			
D3	F23	B/3	: Camshaft position sensor (PHASE) (bank 2)	C3	F125	G/8	: To F26
C2	F24	GR/2	: Engine coolant temperature sensor	B3	F126	GR/3	: Ignition coil No. 1 (with power transistor)
C3	F26	G/8	: To F125	B3	F127	GR/3	: Ignition coil No. 3 (with power transistor)
C3	F27	B/1	: Starter motor	C3	F128	GR/3	: Ignition coil No. 5 (with power transistor)
B2	F32	W/16	: To E2	B3	F129	G/2	: Intake valve timing control solenoid valve (bank 1)
A2	F33	W/16	: To E19	Knock sensor sub-harness			
A2	F39	—	: Fusible link box (battery)	D4	F150	L/4	: To F67
D3	F44	GR/4	: To F101	C4	F151	B/2	: Knock sensor (bank 1)
A4	F46	B/3	: Power steering pressure sensor	C4	F152	B/2	: Knock sensor (bank 2)

# HARNESSES

## CHASSIS HARNESS

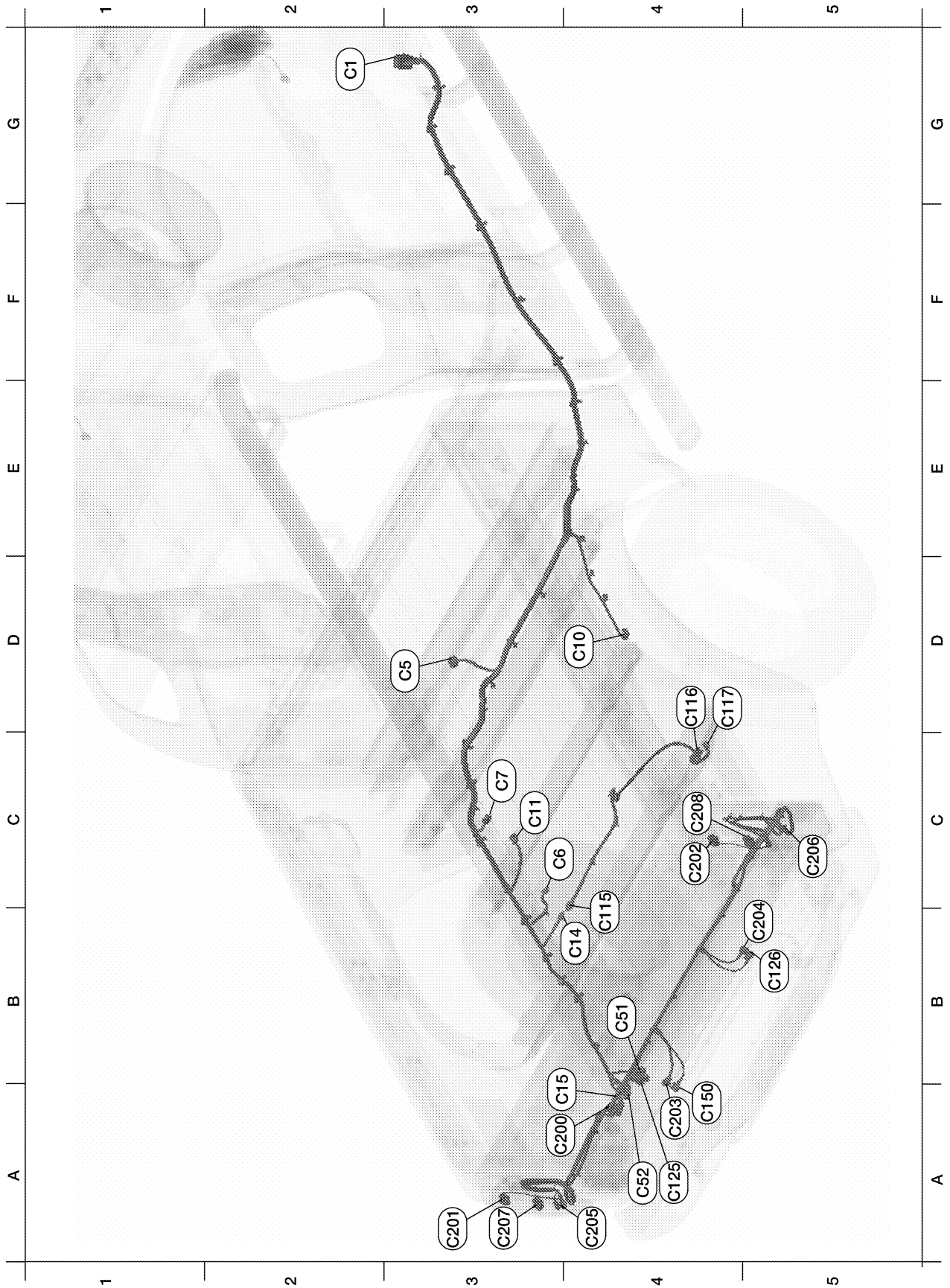

A  
B  
C  
D  
E  
F  
G  
H  
I  
J  
L  
M

PG

LKIA0852E

# HARNESSES

G2	C1	SMJ	: To E41	A4	C125	GR/6	: To C51
D3	C5	GR/5	: Fuel level sensor unit and fuel pump	B5	C126	B/7	: Trailer (7-pin)
C3	C6	B/2	: EVAP canister vent control valve	B5	C126	B/4	: Trailer (4-pin)
C3	C7	GR/3	: EVAP control system pressure sensor	A4	C150	B/2	: To C52
D4	C10	GR/2	: Rear wheel sensor RH	Tail lamp sub-harness			
C3	C11	GR/2	: Rear wheel sensor LH	A3	C200	GR/8	: To C15
B4	C14	GR/4	: To C115	A3	C201	BR/3	: Rear combination lamp LH (tail/stop)
B4	C15	GR/8	: To C200	C4	C202	BR/3	: Rear combination lamp RH (tail/stop)
B4	C51	GR/6	: To C125	A4	C203	GR/2	: License plate lamp LH
A4	C52	B/2	: To C150	B5	C204	GR/2	: License plate lamp RH
Differential lock sub-harness				A4	C205	GR/2	: Rear combination lamp LH (back-up)
B4	C115	GR/4	: To C14	C5	C206	GR/2	: Rear combination lamp RH (back-up)
D4	C116	GR/2	: Differential lock position switch	A3	C207	GR/2	: Rear combination lamp LH (turn signal)
D4	C117	B/2	: Differential lock solenoid	C4	C208	GR/2	: Rear combination lamp RH (turn signal)
Trailer sub-harness							

# HARNESS

## BODY HARNESS (KING CAB MODELS)

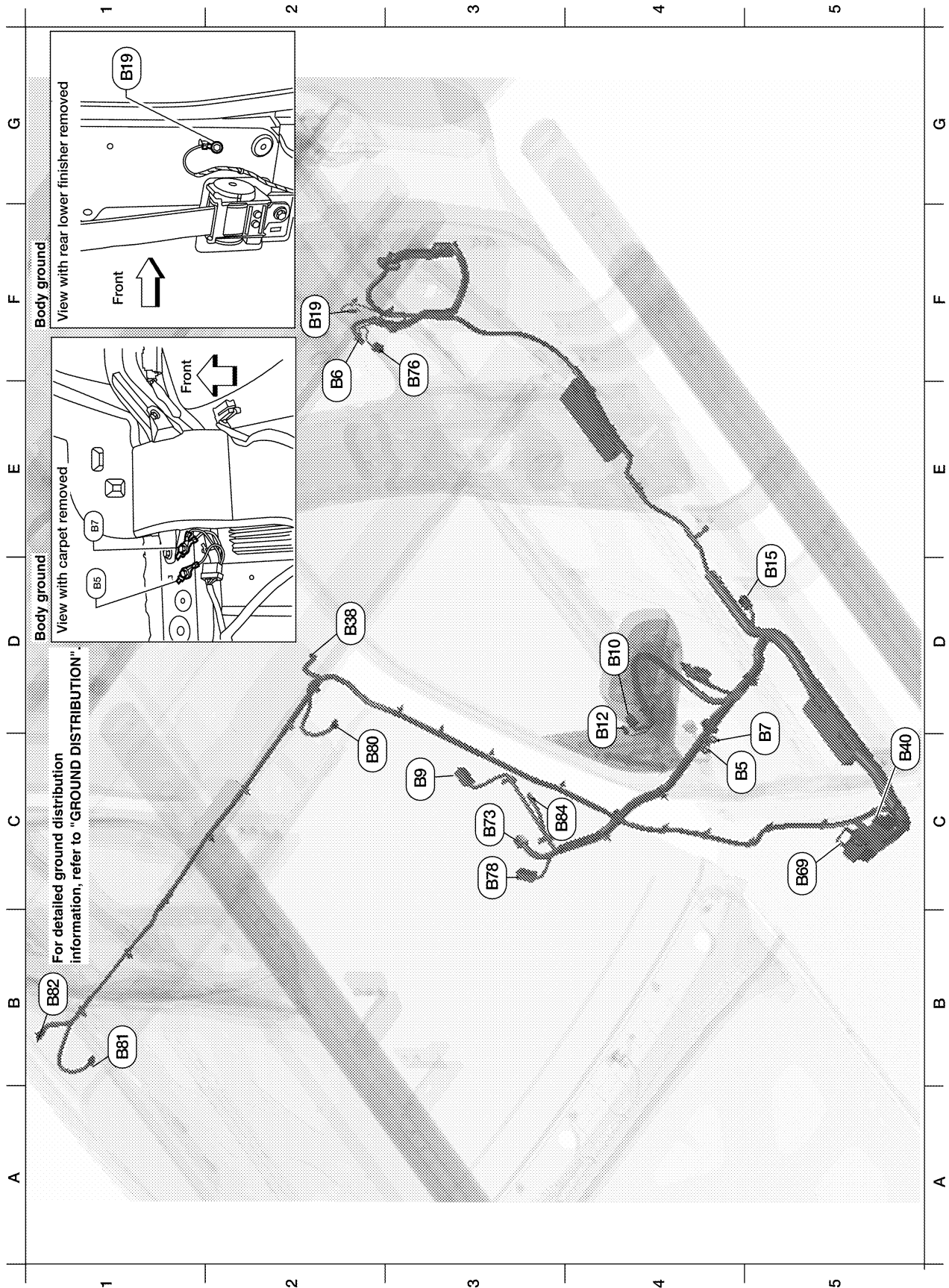

For detailed ground distribution information, refer to "GROUND DISTRIBUTION".

Body ground

Body ground

View with rear lower finisher removed

View with carpet removed

Front

Front

LKIA0844E

PG

# HARNESSES

C5	B5	—	: Body ground (LH satellite sensor)	C5	B40	W/8	: To E34
F2	B6	W/8	: To D201	C5	B69	SMJ	: To M40
C5	B7	—	: Body ground	C3	B73	B/6	: Yaw rate/side/decel G sensor
C3	B9	Y/12	: Air bag diagnosis sensor unit	F3	B76	W/2	: Rear door speaker LH
D4	B10	Y/2	: Front LH side air bag module	C3	B78	Y/2	: To B157
D4	B12	W/3	: Seat belt buckle switch LH	C2	B80	W/2	: Vanity lamp LH
E5	B15	Y/2	: LH side air bag (satellite) sensor	B1	B81	W/2	: Vanity lamp RH
F2	B19	—	: Body ground	B1	B82	Y/2	: RH side curtain air bag module
D2	B38	Y/2	: LH side curtain air bag module	C3	B84	B/1	: Parking brake switch

# HARNESS

## BODY HARNESS (CREW CAB MODELS)

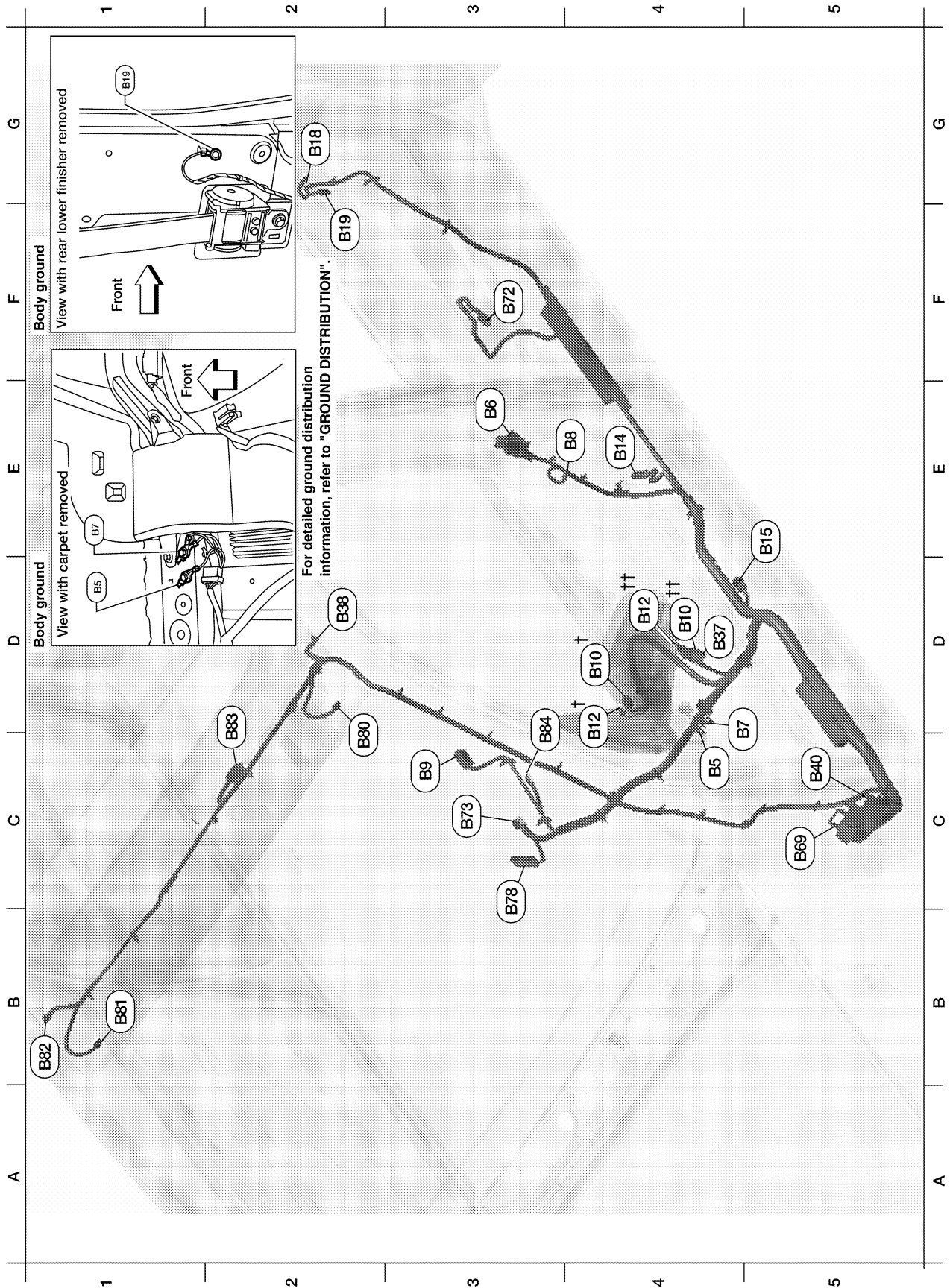

A  
B  
C  
D  
E  
F  
G  
H  
I  
J  
K  
L  
M

PG

LKIA0845E

# HARNESSES

C4	B5	—	: Body ground (LH satellite sensor)
E3	B6	W/12	: To D201
D4	B7	—	: Body ground
E4	B8	W/3	: Front door switch LH
C3	B9	Y/12	: Air bag diagnosis sensor unit
D4	B10†	Y/2	: Front LH side air bag module (without power seat)
D4	B10††	Y/2	: Front LH side air bag module (with power seat)
D4	B12†	W/3	: Seat belt buckle switch LH (without power seat)
D4	B12††	W/3	: Seat belt buckle switch LH (with power seat)
E4	B14	Y/2	: Front LH seat belt pre-tensioner
E5	B15	Y/2	: LH side air bag (satellite) sensor
G2	B18	W/3	: Rear door switch LH
F2	B19	—	: Body ground
D4	B37	W/16	: To P1
D2	B38	Y/2	: LH side curtain air bag module
C5	B40	W/8	: To E34
C5	B69	SMJ	: To M40
F3	B72	GR/4	: Subwoofer (with audio amplifier)
C3	B73	B/6	: Yaw rate/side/decel G sensor
C3	B78	Y/2	: To B157
C2	B80	W/2	: Vanity lamp LH
B1	B81	W/2	: Vanity lamp RH
B1	B82	Y/2	: RH side curtain air bag module
C2	B83	B/10	: Sunroof motor assembly
D3	B84	B/1	: Parking brake switch



# HARNESS

## BODY NO. 2 HARNESS (KING CAB MODELS)

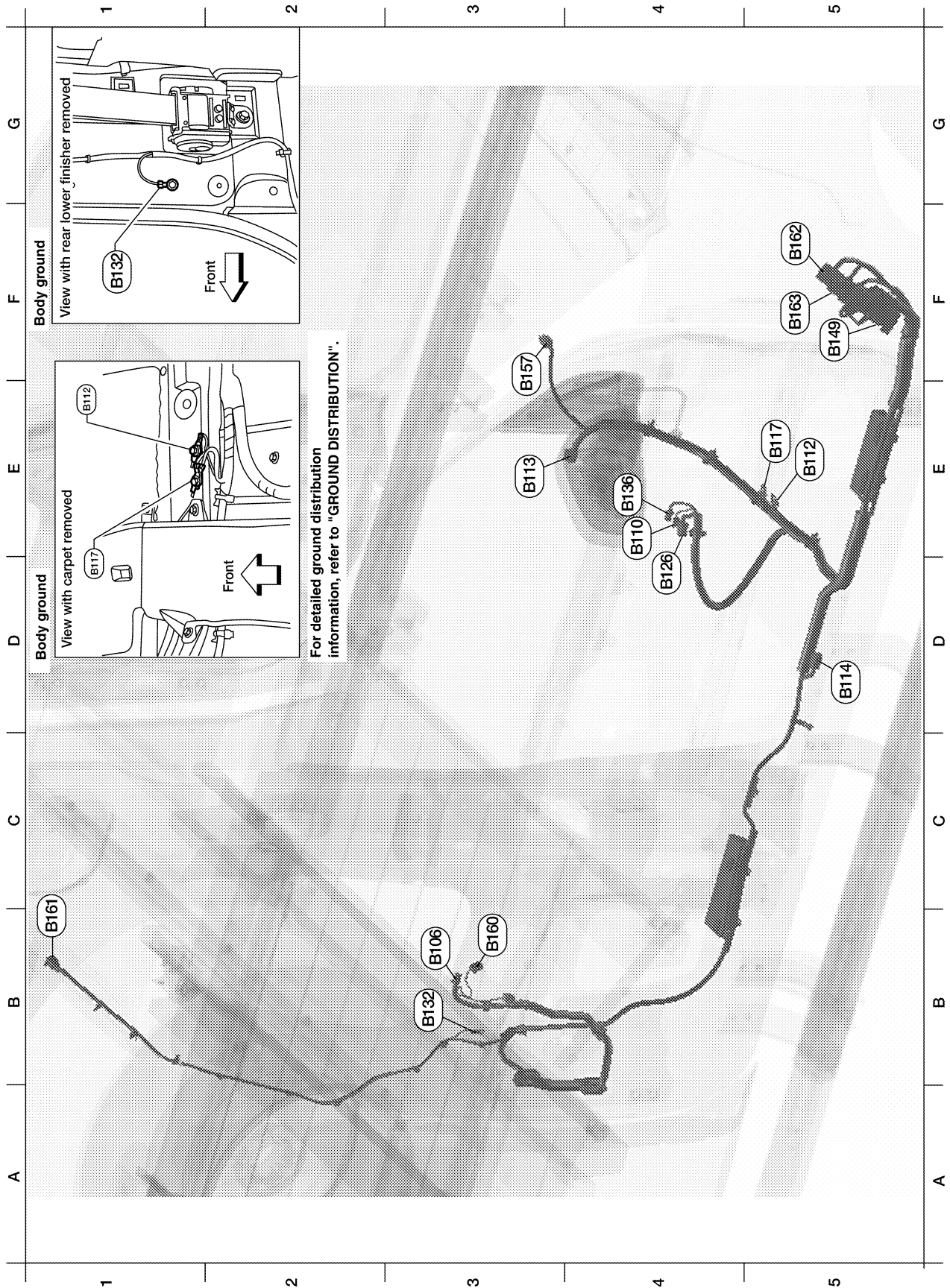

WKIA5880E

A  
B  
C  
D  
E  
F  
G  
H  
I  
J  
L  
M

PG

# HARNESSES

B3	B106	W/8	: To D301
E4	B110	W/3	: Seat belt buckle switch RH
E5	B112	—	: Body ground (RH satellite sensor)
E3	B113	Y/12	: Air bag diagnosis sensor unit
D5	B114	Y/2	: RH side air bag (satellite) sensor
E5	B117	—	: Body ground
D4	B126	Y/2	: Front RH side air bag module
B3	B132	—	: Body ground
E4	B136	W/8	: To P151
F5	B149	SMJ	: To M36
F3	B157	Y/2	: To B78
B3	B160	W/2	: Rear door speaker RH
B1	B161	W/3	: High-mounted stop lamp
F5	B162	W/12	: To M16
F5	B163	W/16	: To M17

# HARNESS

## BODY NO. 2 HARNESS (CREW CAB MODELS)

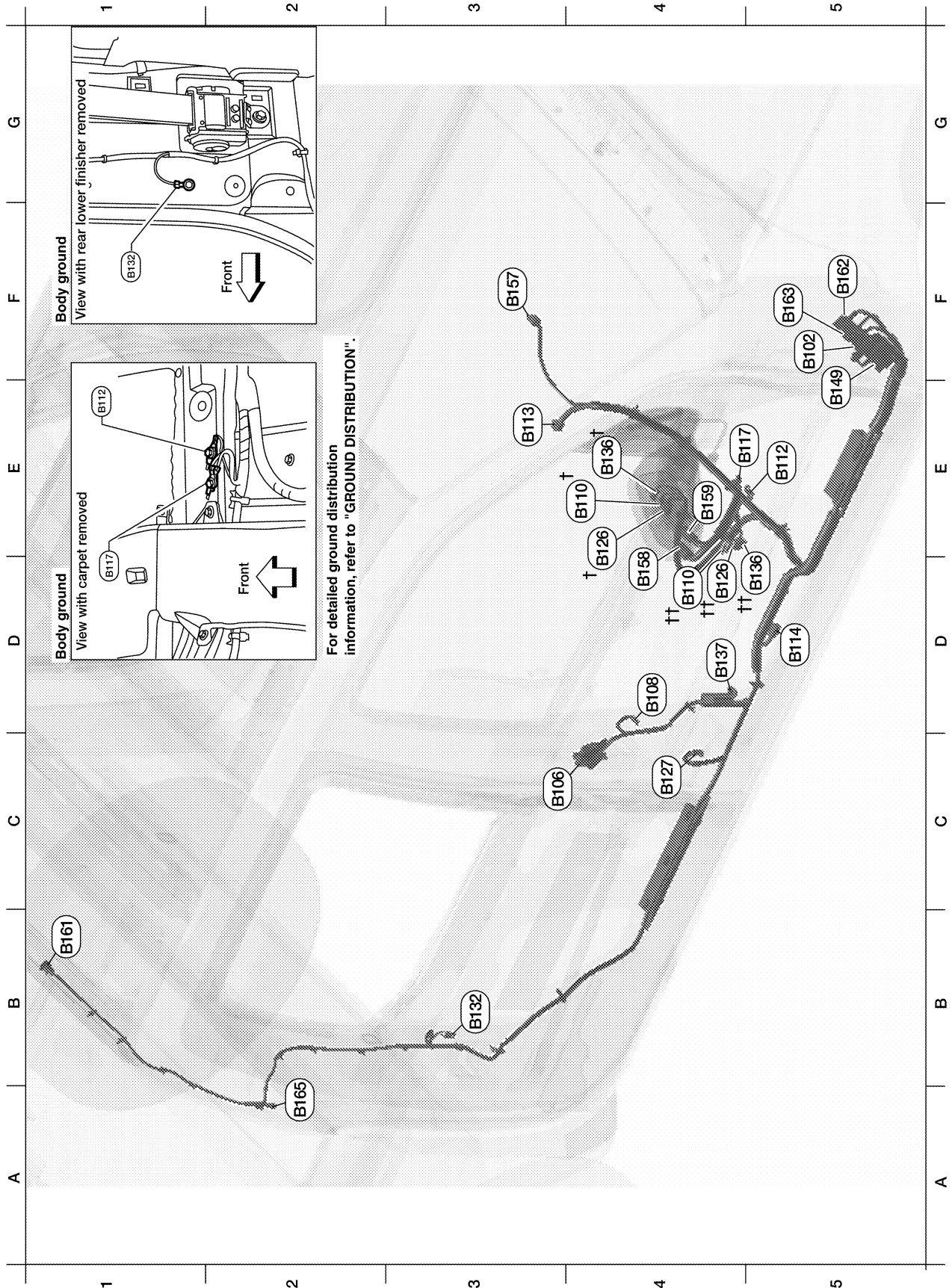

A  
B  
C  
D  
E  
F  
G  
H  
I  
J  
K  
L  
M

PG

WKIA5881E

# HARNESSES

F5	B102	W/2	: To E36	C4	B127	Y/2	: Front RH seat belt pretensioner
C3	B106	W/12	: To D301	B3	B132	—	: Body ground
D4	B108	W/3	: To D301	E4	B136 †	W/8	: To P151 (without power seat)
E4	B110†	W/3	: Front door switch RH (without power seat)	D5	B136 ††	W/16	: To P151 (with power seat)
D4	B110††	W/3	: Front door switch RH (with power seat)	D4	B137	B/3	: Belt tension sensor
E5	B112	—	: Body ground (RH satellite sensor)	E5	B149	SMJ	: To M36
E3	B113	Y/12	: Air bag diagnosis sensor unit	F3	B157	Y/2	: To B78
D5	B114	Y/2	: RH side air bag (satellite) sensor	D4	B158	W/8	: Audio amplifier
E4	B117	—	: Body ground	E4	B159	W/24	: Audio amplifier
E4	B126†	Y/2	: Front RH side air bag module (without power seat)	B1	B161	W/3	: High-mounted stop lamp
D4	B126††	Y/2	: Front RH side air bag module (with power seat)	F5	B162	W/12	: To M16

# HARNESS

## ROOM LAMP HARNESS

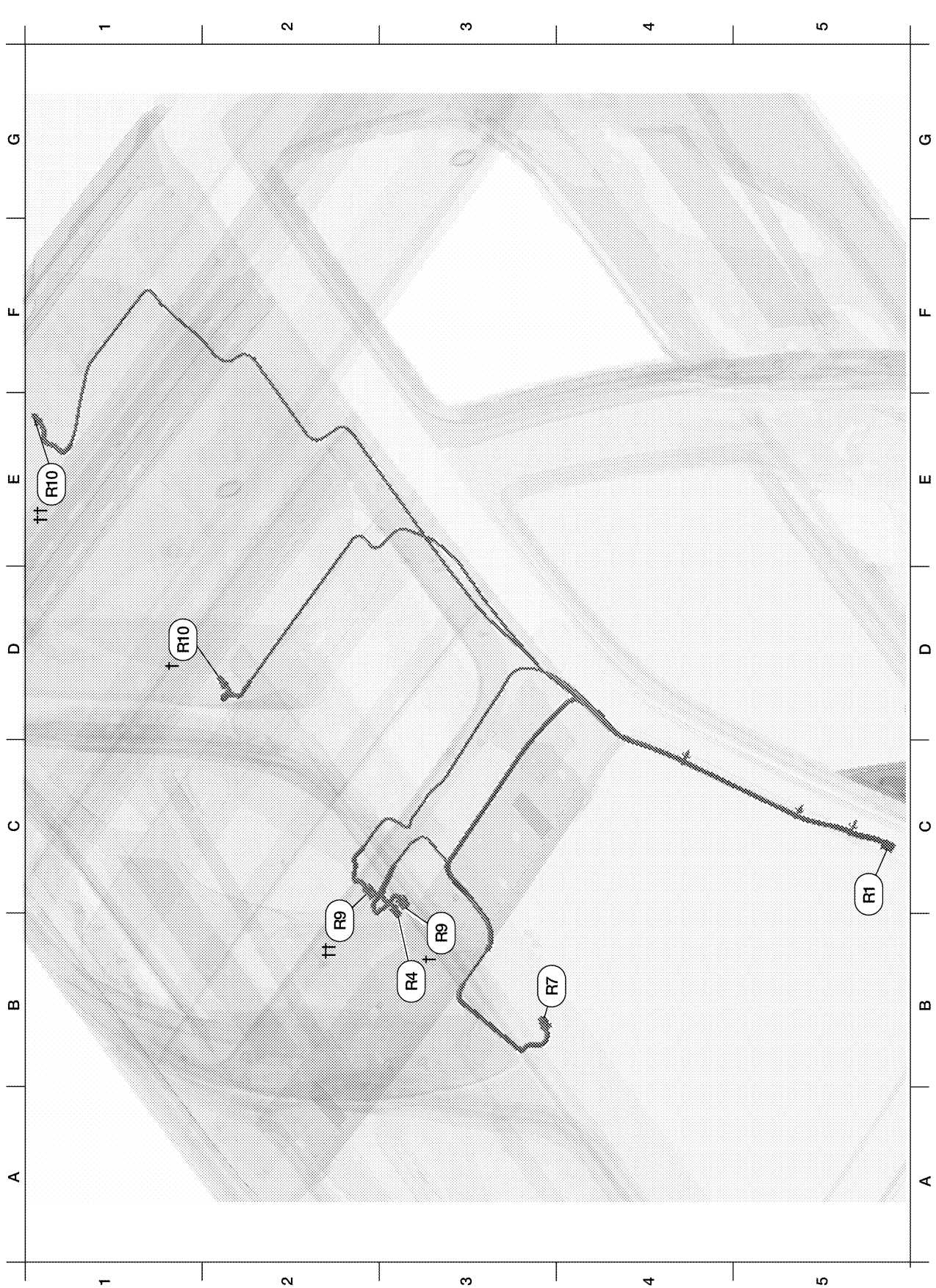

A  
B  
C  
D  
E  
F  
G  
H  
I  
J  
PG  
L  
M

LKIA0646E

# HARNESSES

C5	R1	W/12	: To M1
B3	R4	W/3	: Sunroof switch
B4	R7	B/10	: Auto anti-dazzling inside mirror (with HOMELINK universal transceiver)
B3	R9†	W/3	: Front room/map lamp assembly (with sunroof)
B2	R9††	W/3	: Front room/map lamp assembly (without sun roof)
E1	R10††	W/2	: Room lamp 2nd row (Crew cab models)
D1	R10†	W/2	: Room lamp 2nd row (King cab models)

# HARNESS

## FRONT DOOR LH HARNESS

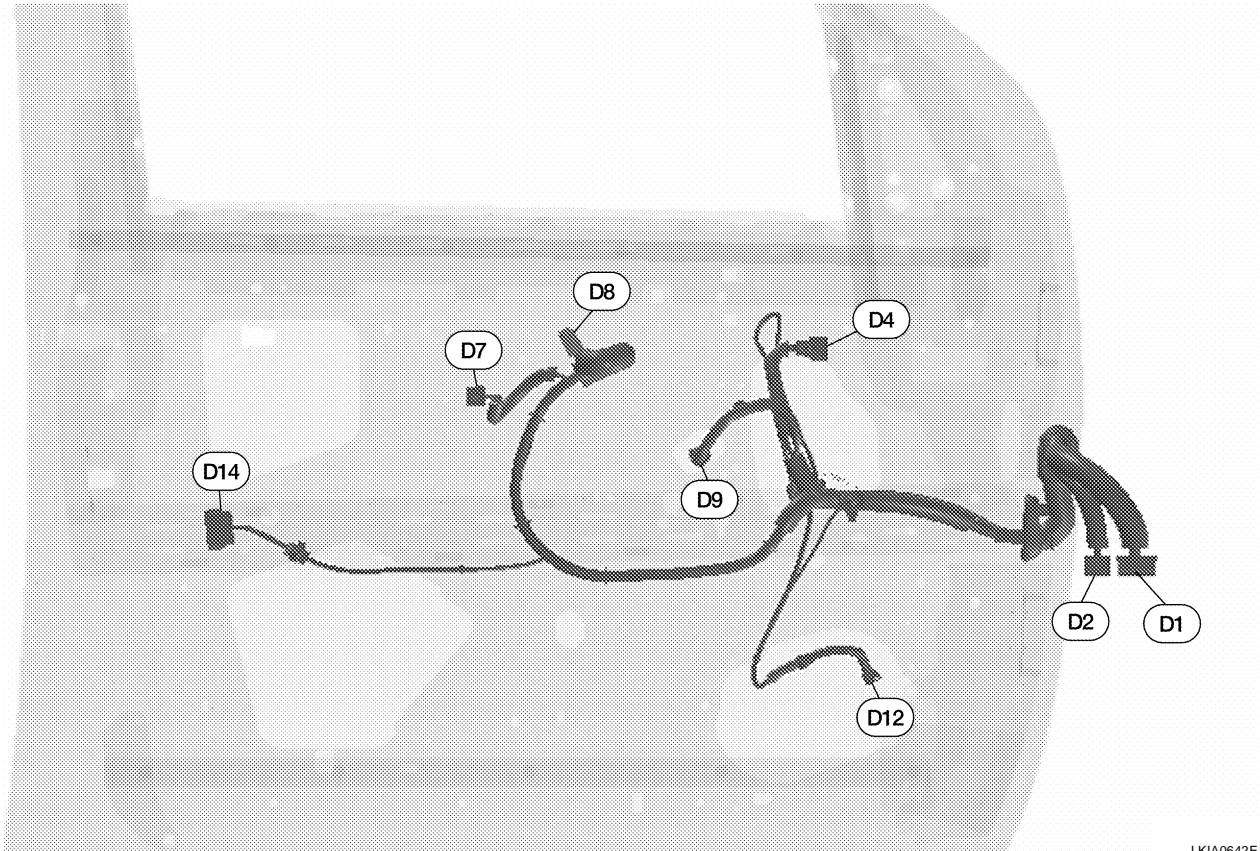

LKIA0642E

D1	W/24	: To M9	D8	W/3	: Main power window and door lock/unlock switch
D2	W/16	: To M8	D9	GR/2	: Front power window motor LH
D4	B/10	: Door mirror remote control switch	D12	W/2	: Front door speaker LH
D7	W/16	: Main power window and door lock/unlock switch	D14	GR/6	: Front door lock actuator LH

# HARNESS

## FRONT DOOR RH HARNESS

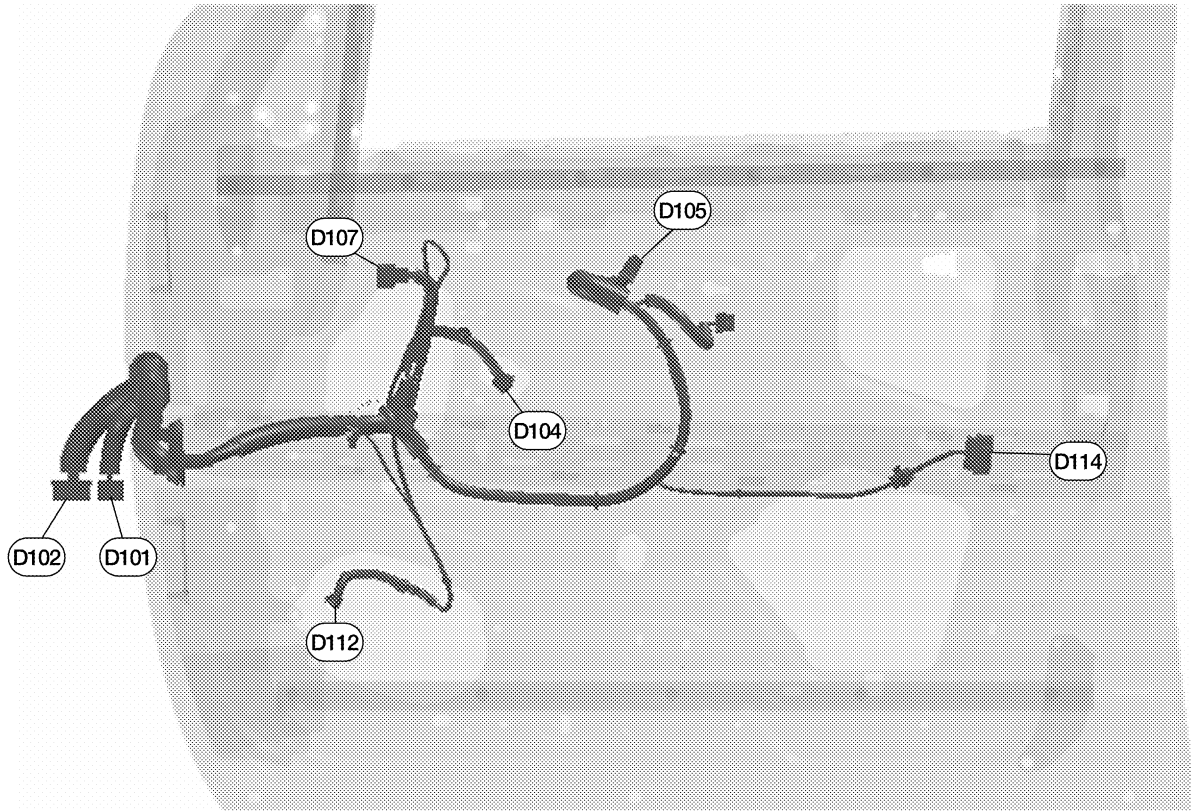

LKIA0643E

D101	W/12	: To M75	D107	B/10	Door mirror RH
D102	W/16	: To M74	D112	W/2	Front door speaker RH
D104	GR/2	: Front power window motor RH	D114	BR/2	Front door lock actuator RH
D105	W/12	: Power window and door lock/unlock switch			



# HARNESS

## REAR DOOR LH HARNESS (KING CAB MODELS)

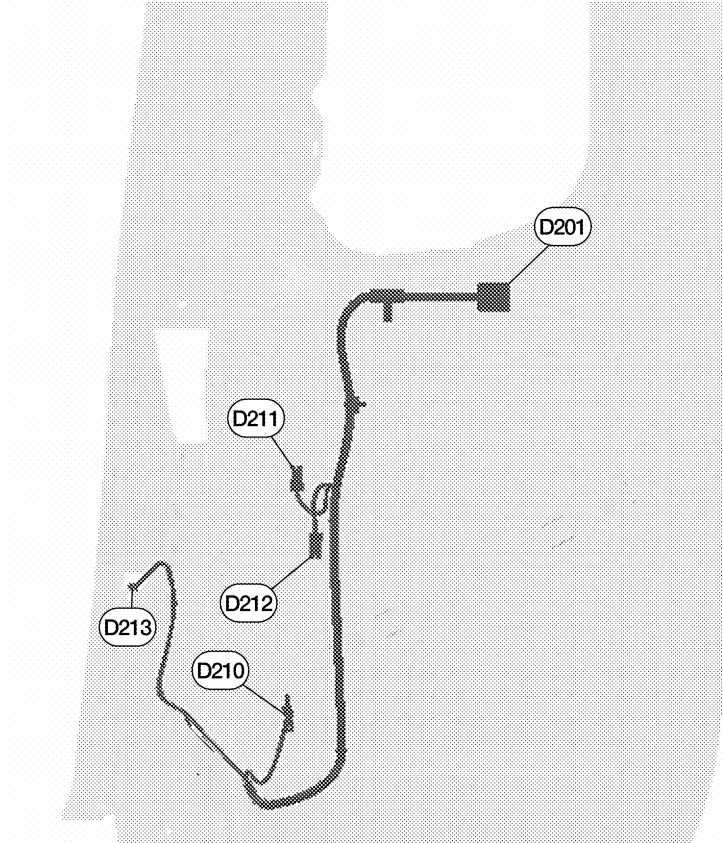

LKIA0644E

D201	W/8	: To B6	D212	GR/2	: Rear door switch lower LH
D210	Y/2	: Front LH seat belt pre-tensioner	D213	W/3	: Front door switch LH
D211	B/2	: Rear door switch upper LH			

A  
B  
C  
D  
E  
F  
G  
H  
I  
J  
L  
M

**PG**

# HARNESS

## REAR DOOR RH HARNESS (KING CAB MODELS)

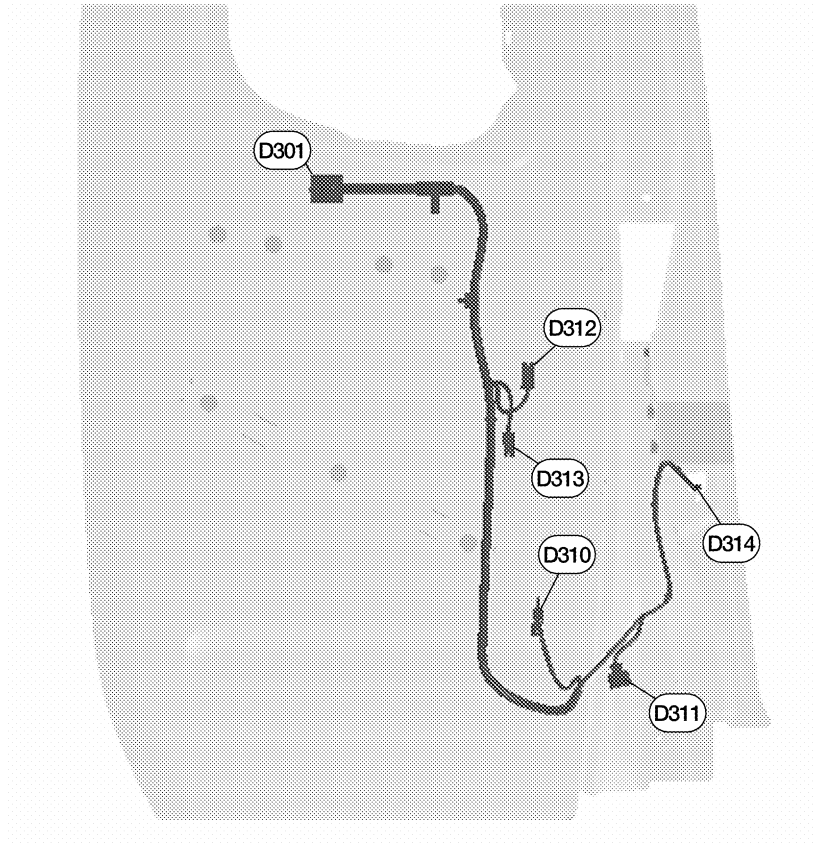

LKIA0645E

D301	W/8	: To B106	D312	B/2	: Rear door switch upper RH
D310	Y/2	: Front RH seat belt pre-tensioner	D313	B/2	: Rear door switch lower RH
D311	B/3	: Belt tension sensor	D314	W/3	: Front door switch RH

# HARNESS

## REAR DOOR LH HARNESS (CREW CAB MODELS)

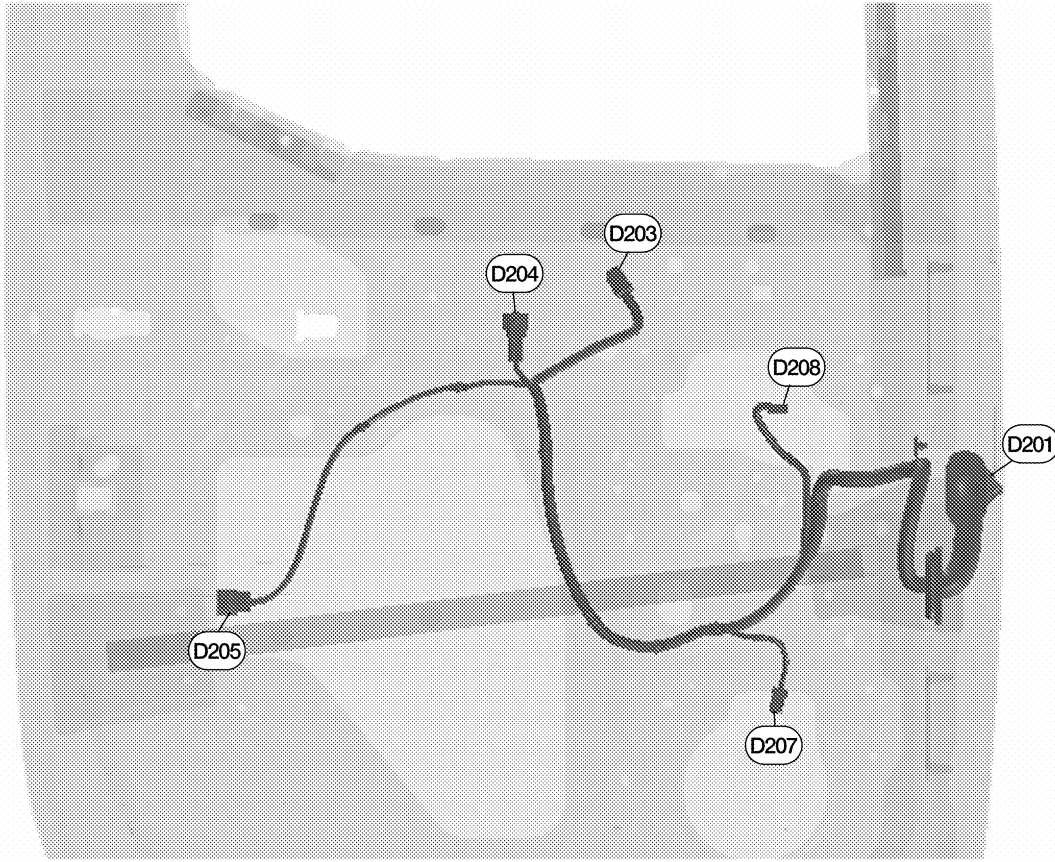

LKIA0647E

D201	W/12	: To B6	D207	W/2	: Rear door speaker LH (base audio)
D203	W/8	: Rear power window switch LH	D207	BR/2	: Rear door speaker LH (premium audio)
D204	B/2	: Rear power window motor LH	D208	BR/2	: Rear door tweeter LH
D205	BR/2	: Rear door lock actuator LH			

A

B

C

D

E

F

G

H

I

J

PG

L

M

# HARNESS

## REAR DOOR RH HARNESS (CREW CAB MODELS)



LKIA0649E

D301	W/12	: To B106	D307	W/2	: Rear door speaker RH (base audio)
D303	W/8	: Rear power window switch RH	D307	BR/2	: Rear door speaker RH (premium audio)
D304	B/2	: Rear power window motor RH	D308	BR/2	: Rear door tweeter RH
D305	BR/2	: Rear door lock actuator RH			

# HARNESS

## Wiring Diagram Codes (Cell Codes)

EKS00E0T

Use the chart below to find out what each wiring diagram code stands for.

Refer to the wiring diagram code in the alphabetical index to find the location (page number) of each wiring diagram.

Code	Section	Wiring Diagram Name
A/C,M	MTC	Manual Air Conditioner
A/F	EC	Air Fuel Ratio (A/F) Sensor
A/FH	EC	Air Fuel Ratio (A/F) Sensor Heater
ABLS	BRC	Anti-Lock Brake System Limited Slip
ABS	BRC	Anti-Lock Brake System
AF1B1	EC	Air Fuel Ratio (A/F) Sensor 1 Bank 1
AF1B2	EC	Air Fuel Ratio (A/F) Sensor 1 Bank 2
AF1HB1	EC	Air Fuel Ratio (A/F) Sensor 1 Heater Bank 1
AF1HB2	EC	Air Fuel Ratio (A/F) Sensor 1 Heater Bank 2
APPS1	EC	Accelerator Pedal Position Sensor
APPS2	EC	Accelerator Pedal Position Sensor
APPS3	EC	Accelerator Pedal Position Sensor
ASC/BS	EC	ASCD Brake Switch
ASC/SW	EC	ASCD Steering Switch
ASCBOF	EC	ASCD Brake Switch
ASCIND	EC	ASCD Indicator
AT/IND	DI	A/T Indicator Lamp
AUDIO	AV	Audio
AUTO/L	LT	Auto Light Control
B/COMP	DI	Combination Meter Board Computer
BACK/L	LT	Back-up Lamp
BRK/SW	EC	Brake Switch
CAN	AT	CAN Communication Line
CAN	EC	CAN Communication Line
CAN	LAN	CAN System
CHARGE	SC	Charging System
CHIME	DI	Warning Chime
COOL/F	EC	Cooling Fan Control
COMBSW	LT	Combination Switch
COMPAS	DI	Compass
CUR/SE	EC	Battery Current Sensor
D/LOCK	BL	Power Door Lock
DEF	GW	Rear Window Defogger
DTRL	LT	Headlamp - With Daytime Light System
DIFLOC	RFD	Electronic Locking Differential
ECM/PW	EC	ECM Power Supply for Back-Up
ECTS	EC	Engine Coolant Temperature Sensor
ETC1	EC	Electric Throttle Control Function
ETC2	EC	Throttle Control Motor Relay
ETC3	EC	Throttle Control Motor
F/FOG	LT	Front Fog Lamp
F/PUMP	EC	Fuel Pump
FTS	AT	A/T Fluid Temperature Sensor
FTTS	EC	Fuel Tank Temperature Sensor
FUEL	EC	Fuel Injection System Function
FUELB1	EC	Fuel Injection System Bank 1
FUELB2	EC	Fuel Injection System Bank 2

# HARNESSES

HEATER	MTC	Heater System
H/LAMP	LT	Headlamp
H/MIRR	GW	Door Mirror With Heated Mirror
HO2S2H	EC	Heated Oxygen Sensor 2 Heater
HO2S2	EC	Heated Oxygen Sensor 2
HORN	WW	Horn
HSEAT	SE	Heated Seat
I/MIRR	GW	Inside Mirror (Auto Anti-Dazzling Mirror)
IATS	EC	Intake Air Temperature Sensor
IGNSYS	EC	Ignition System
ILL	LT	Illumination
INJECT	EC	Injectors
INT/L	LT	Room/Map, Vanity, Cargo, and Personal Lamps
IVC	EC	Intake Valve Timing Control Solenoid Valve
IVCB1	EC	Intake Valve Timing Control Solenoid Valve Bank 1
IVCB2	EC	Intake Valve Timing Control Solenoid Valve Bank 2
KEYLES	BL	Remote Keyless Entry System
KS	EC	Knock Sensor
MAFS	EC	Mass Air Flow Sensor
MAIN	AT	Main Power Supply and Ground Circuit
MAIN	EC	Main Power Supply and Ground Circuit
METER	DI	Speedometer, Tachometer, Temp. and Fuel Gauges
MIL/DL	EC	Malfunction Indicator Lamp
MIRROR	GW	Door Mirror
NATS	BL	Nissan Anti-Theft System
NONDTC	AT	Non-Detective Items
O2H2B1	EC	Rear Heated Oxygen Sensor 2 Heater Bank 1
O2H2B2	EC	Rear Heated Oxygen Sensor 2 Heater Bank 2
O2S2B1	EC	Heated Oxygen Sensor 2 Bank 1
O2S2B2	EC	Heated Oxygen Sensor 2 Bank 2
P/SCKT	WW	Power Socket
PGC/V	EC	EVAP Canister Purge Volume Control Solenoid Valve
PHASE	EC	Camshaft Position Sensor (PHASE)
PHSB1	EC	Camshaft Position Sensor (PHASE) (Bank 1)
PHSB2	EC	Camshaft Position Sensor (PHASE) (Bank 1)
PNP/SW	AT	Park/Neutral Position Switch
PNP/SW	EC	Park/Neutral Position Switch
POS	EC	Crankshaft Position Sensor (POS)
POWER	PG	Power Supply Routing
PRE/SE	EC	EVAP Control System Pressure Sensor
PS/SEN	EC	Power Steering Pressure Sensor
RP/SEN	EC	Refrigerant Pressure Sensor
SEAT	SE	Power Seat
SEN/PW	EC	Sensor Power Supply
SHIFT	AT	A/T Shift Lock System
SROOF	RF	Sunroof
SRS	SRS	Supplemental Restraint System
STSIG	AT	Start Signal Circuit
START	SC	Starting System
STOP/L	LT	Stop Lamp
T/TOW	LT	Trailer Tow
T/WARN	WT	Low Tire Pressure Warning System

# HARNESSES

TAIL/L	LT	Parking, License and Tail Lamps	
T/F	TF	Transfer Case	A
TPS1	EC	Throttle Position Sensor	
TPS2	EC	Throttle Position Sensor	
TPS3	EC	Throttle Position Sensor	B
TRNSCV	BL	HOMELINK® Universal Transceiver	
TURN	LT	Turn Signal and Hazard Warning Lamps	
VDC	BRC	Vehicle Dynamic Control System	C
VEHSEC	BL	Vehicle security (theft warning) system	
VENT/V	EC	EVAP Canister Vent Control Valve	
VIAS	EC	Variable Air Induction Control System	D
VIAS/V	EC	Variable Air Induction Control System Valve	
VSSA/T	AT	Vehicle Speed Sensor A/T (Revolution Sensor)	
WARN	DI	Warning Lamps	E
WINDOW	GW	Power Window	
WIPER	WW	Front Wiper and Washer	F

A  
B  
C  
D  
E  
F

G

H

I

J

**PG**

L

M

# ELECTRICAL UNITS LOCATION

## ELECTRICAL UNITS LOCATION

PF2:25230

### Electrical Units Location ENGINE COMPARTMENT

EKS00E0U

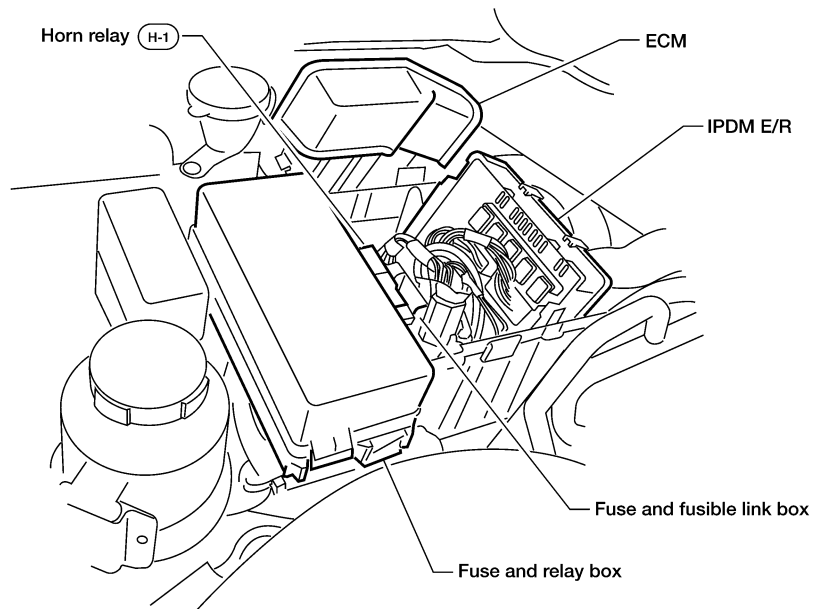
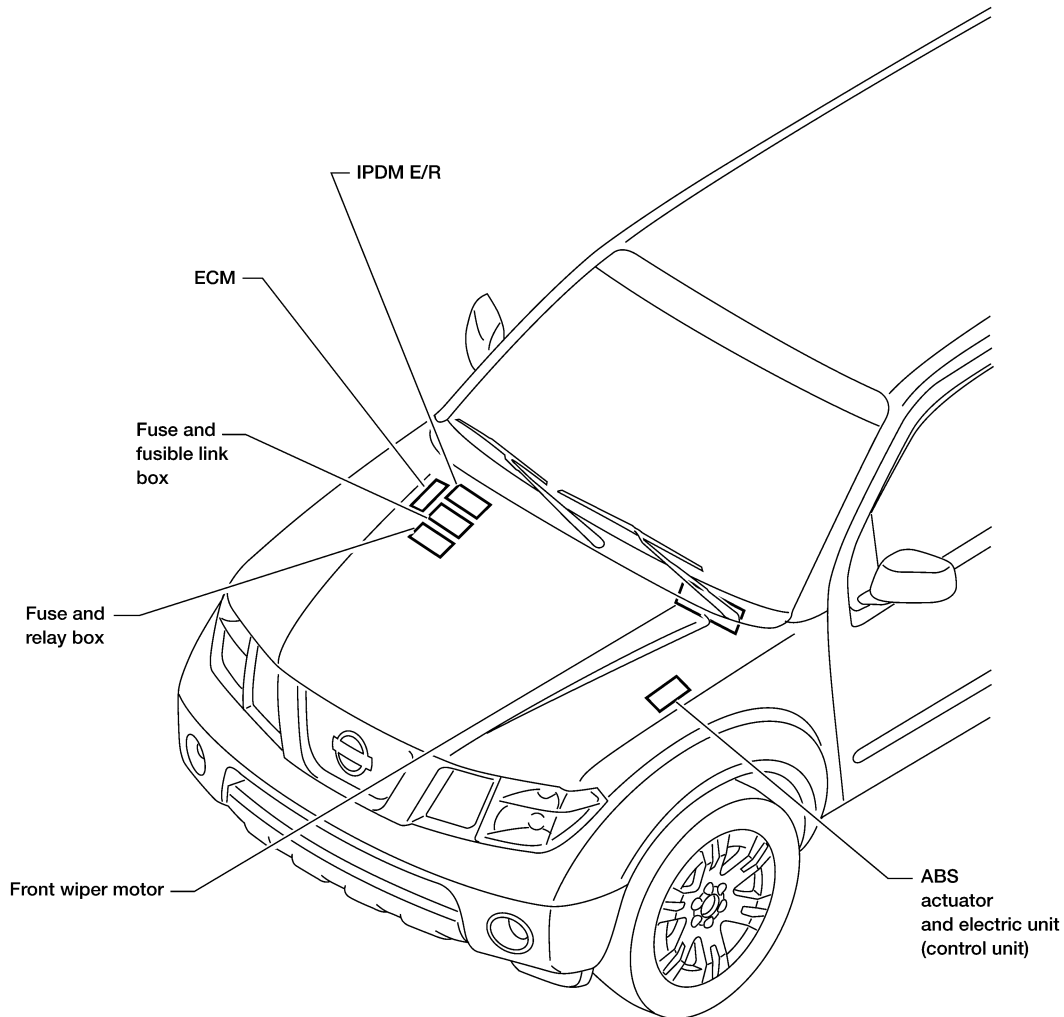



# ELECTRICAL UNITS LOCATION

## PASSENGER COMPARTMENT

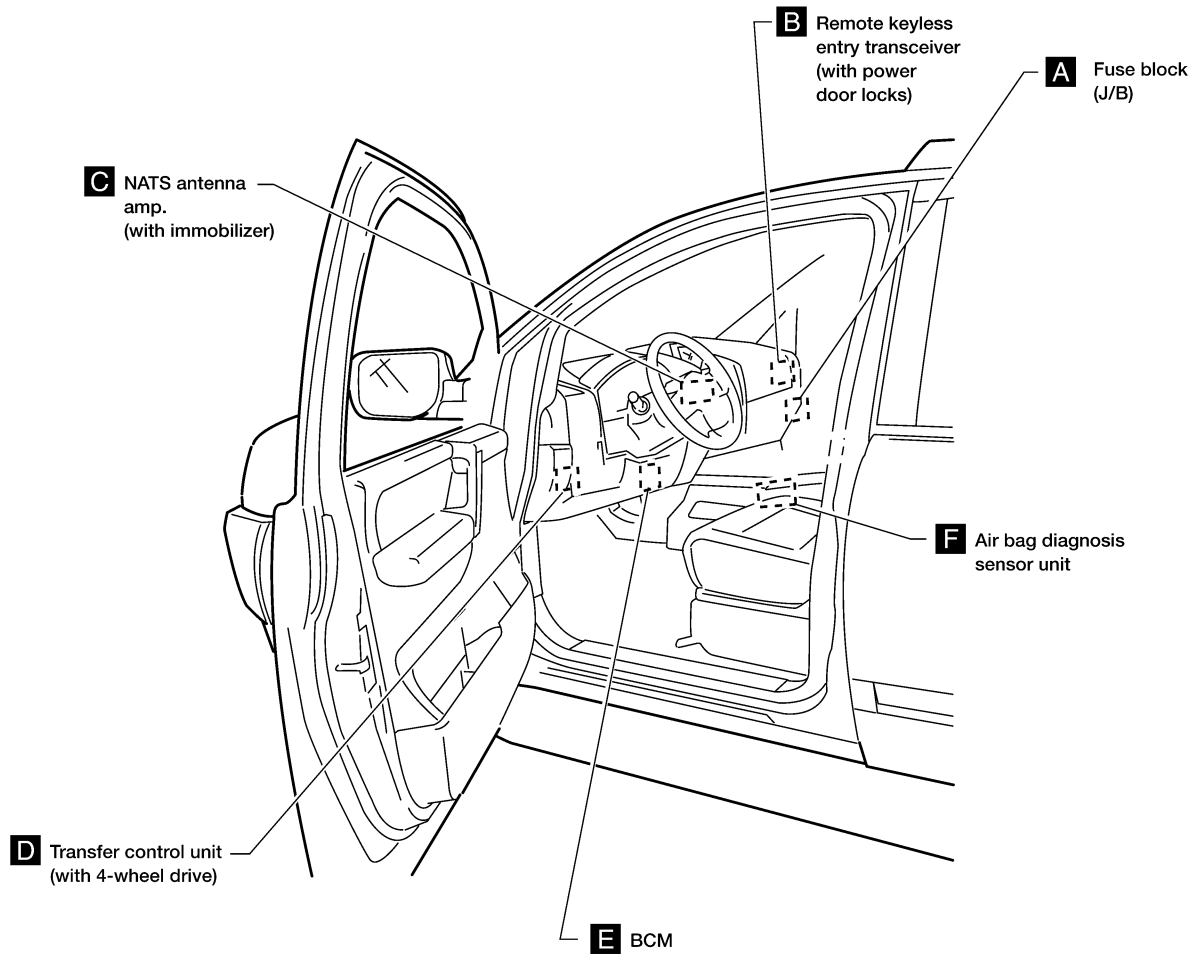

### **A** Instrument panel side RH

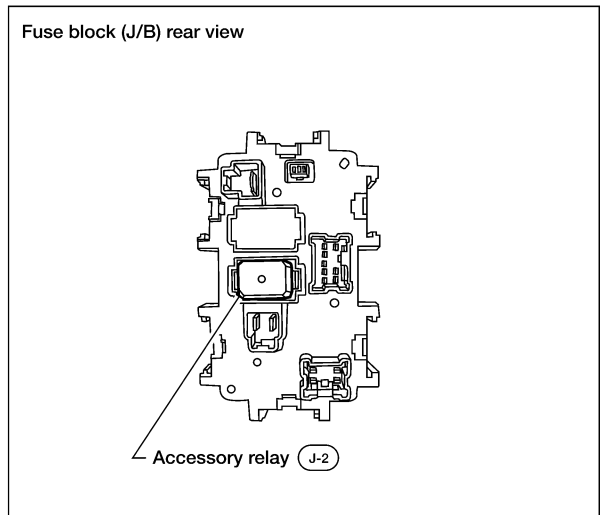
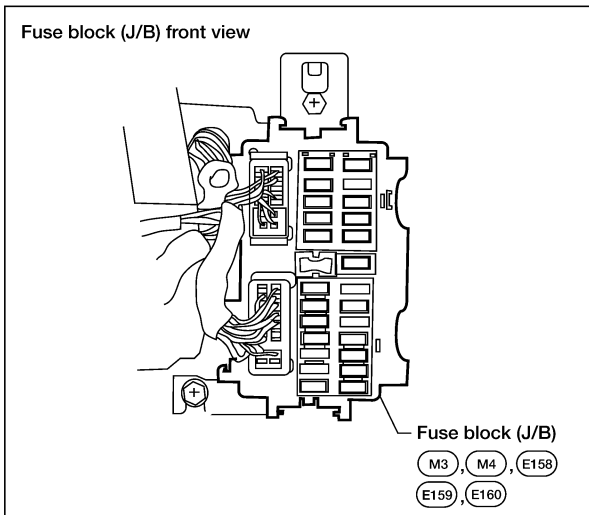

WKIA5064E

# ELECTRICAL UNITS LOCATION

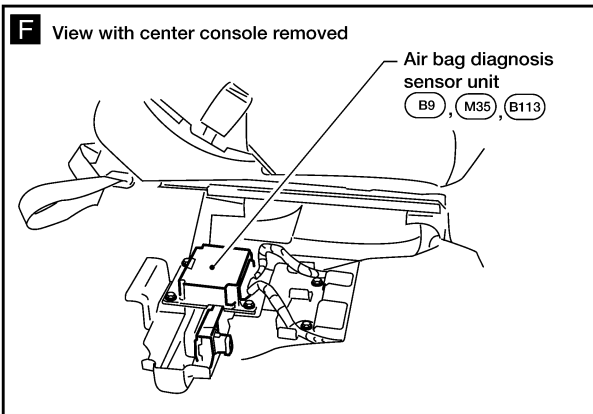
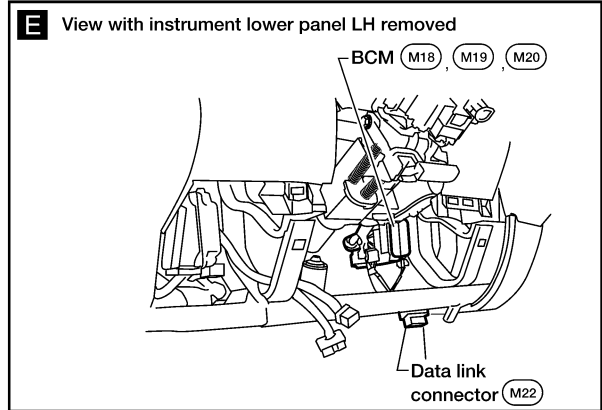
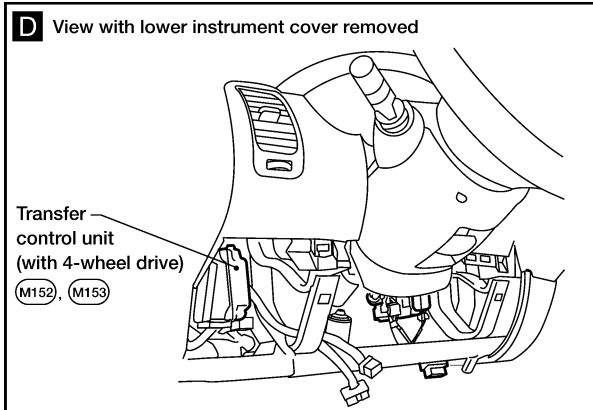
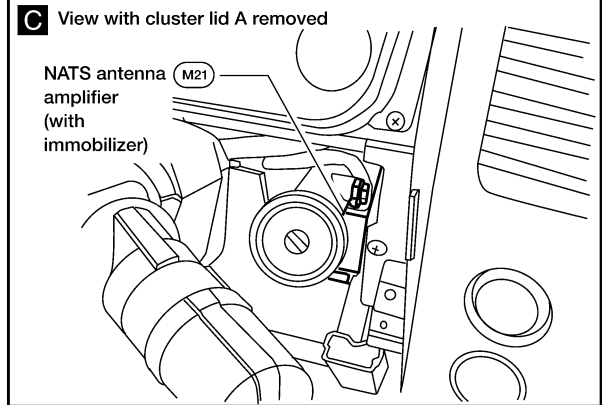
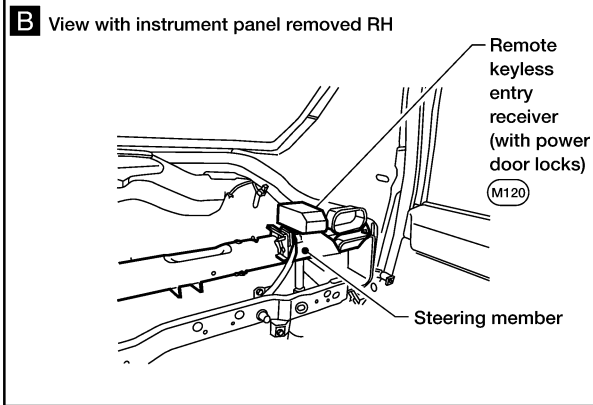

WKIA5066E

# HARNESS CONNECTOR

## HARNESS CONNECTOR

PFP:B4341

EKS00EOY

### Description

#### HARNESS CONNECTOR (TAB-LOCKING TYPE)

- The tab-locking type connectors help prevent accidental looseness or disconnection.
- The tab-locking type connectors are disconnected by pushing or lifting the locking tab(s). Refer to the illustration below.

Refer to the next page for description of the slide-locking type connector.

#### CAUTION:

Do not pull the harness or wires when disconnecting the connector.

[Example]

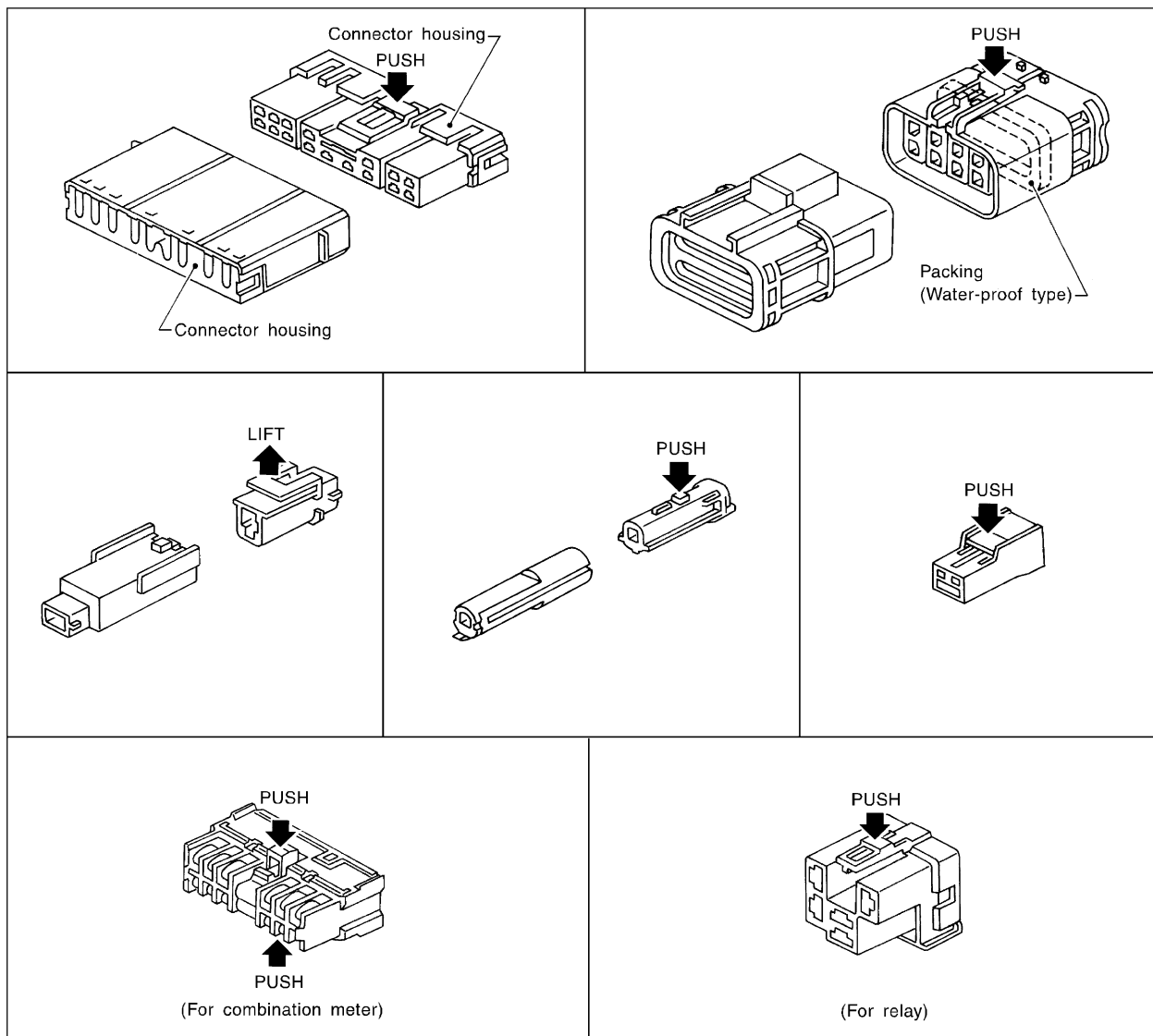

A  
B  
C  
D  
E  
F  
G  
H  
I  
J  
PG  
L  
M

# HARNESS CONNECTOR

## HARNESS CONNECTOR (SLIDE-LOCKING TYPE)

- A new style slide-locking type connector is used on certain systems and components, especially those related to OBD.
- The slide-locking type connectors help prevent incomplete locking and accidental looseness or disconnection.
- The slide-locking type connectors are disconnected by pushing or pulling the slider. Refer to the illustration below.

### CAUTION:

- Do not pull the harness or wires when disconnecting the connector.
- Be careful not to damage the connector support bracket when disconnecting the connector.

[Example]

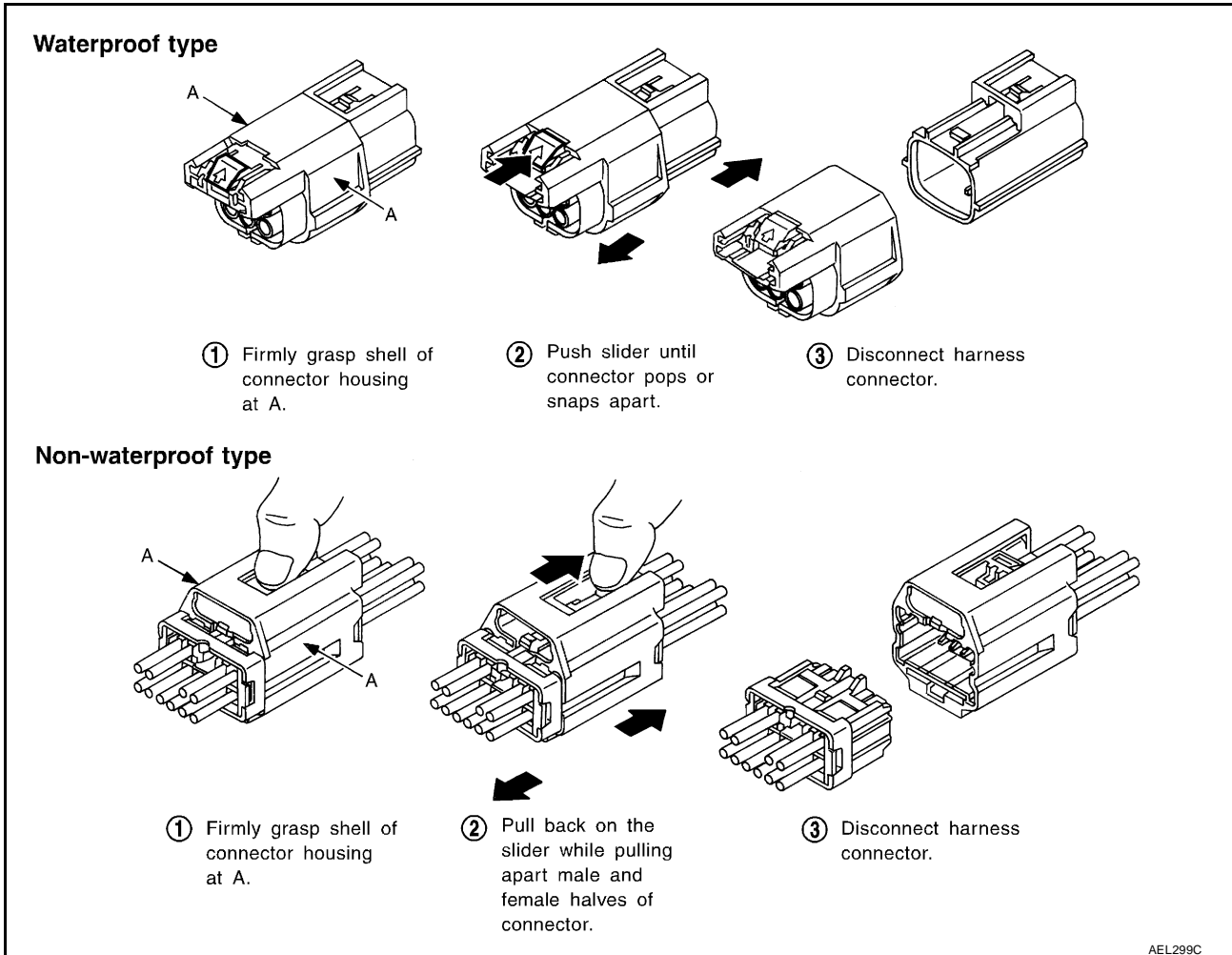

# HARNESS CONNECTOR

## HARNESS CONNECTOR (LEVER LOCKING TYPE)

- Lever locking type harness connectors are used on certain control units and control modules such as ECM, ABS actuator and electric unit (control unit), etc.
- Lever locking type harness connectors are also used on super multiple junction (SMJ) connectors.
- Always confirm the lever is fully locked in place by moving the lever as far as it will go to ensure full connection.

**CAUTION:**

Always confirm the lever is fully released (loosened) before attempting to disconnect or connect these connectors to avoid damage to the connector housing or terminals.

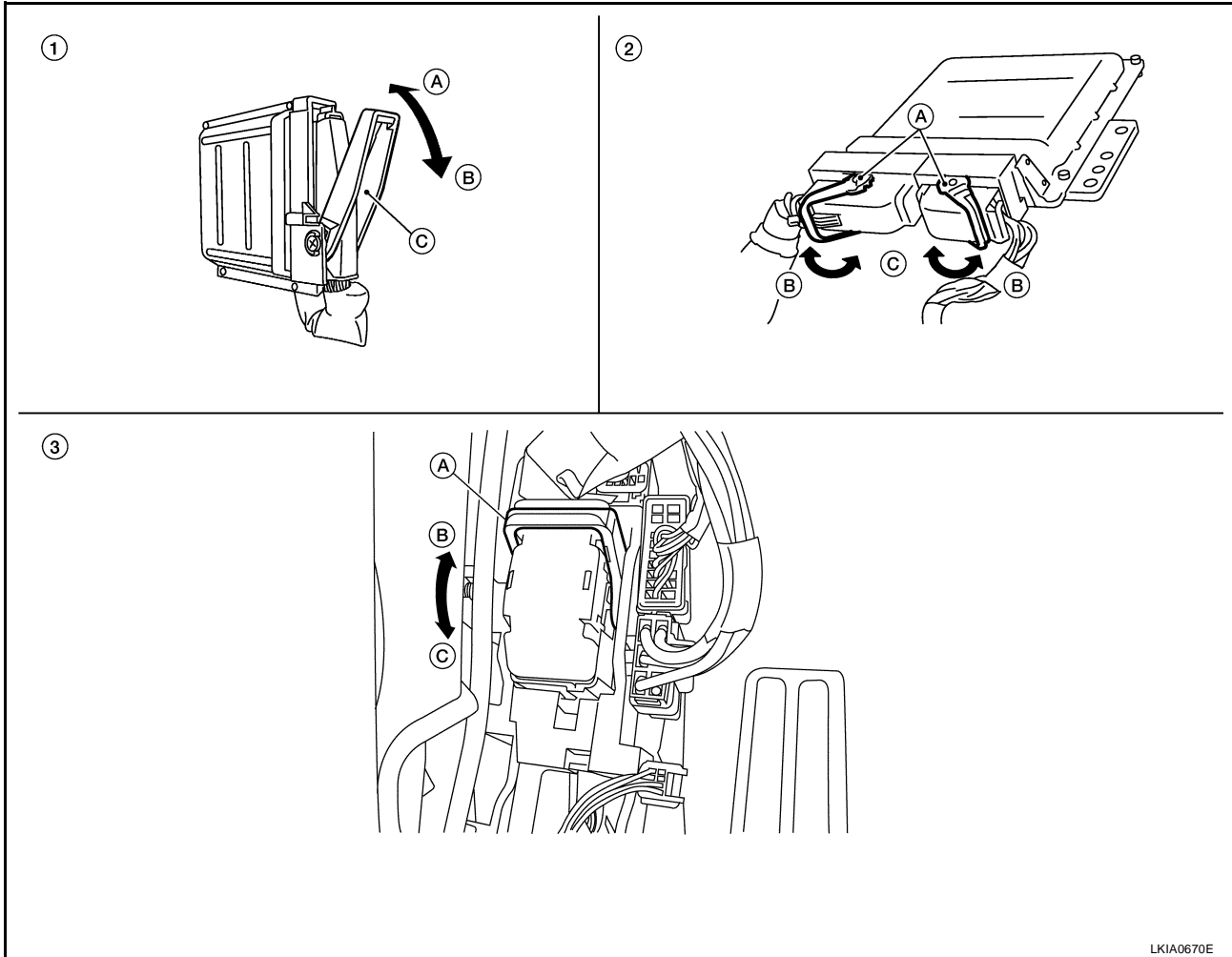

1. Control unit with single lever  
A. Fasten  
B. Loosen  
C. Lever

2. Control unit with dual levers  
A. Levers  
B. Fasten  
C. Loosen

3. SMJ connector  
A. Lever  
B. Fasten  
C. Loosen

LKIA0670E

A  
B  
C  
D  
E  
F  
G  
H  
I  
J  
PG  
L  
M

# HARNES CONNECTOR

## HARNES CONNECTOR (DIRECT-CONNECT SRS COMPONENT TYPE)

- SRS direct-connect type harness connectors are used on certain SRS components such as air bag modules and seat belt pre-tensioners.
- Always pull up to release black locking tab prior to removing connector from SRS component.
- Always push down to lock black locking tab after installing connector to SRS component. When locked, the black locking tab is level with the connector housing.

### CAUTION:

- **Do not pull the harness or wires when removing connectors from SRS components.**

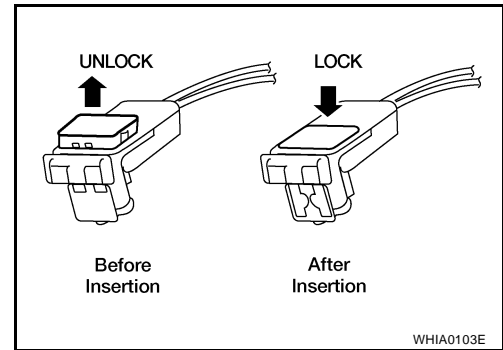

# ELECTRICAL UNITS

## ELECTRICAL UNITS Terminal Arrangement

PF2:23710

EKS00EOZ

### BCM (BODY CONTROL MODULE)

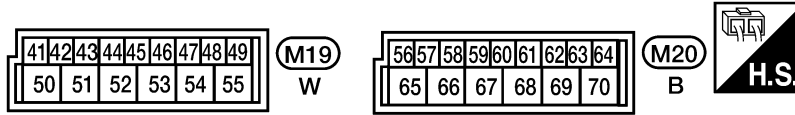
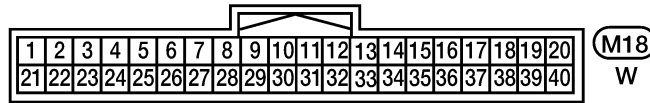

### ABS ACTUATOR AND ELECTRIC UNIT (CONTROL UNIT)

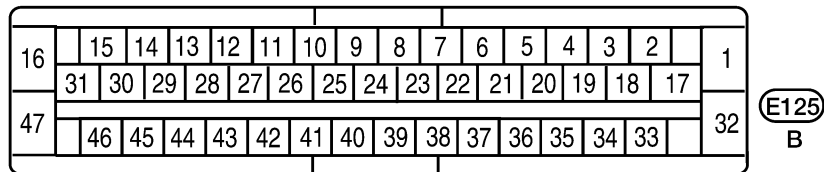

### ECM

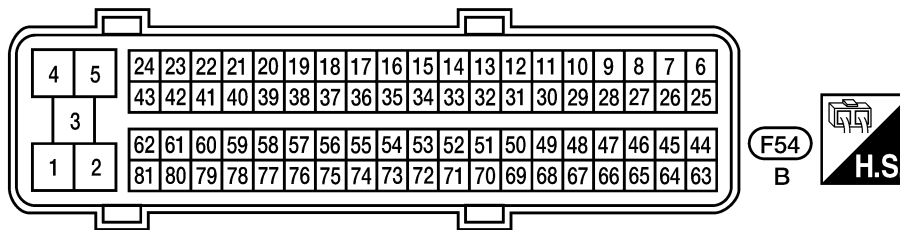
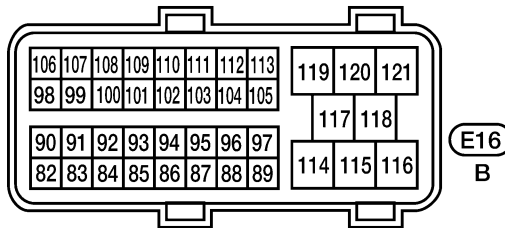

### TRANSFER CONTROL UNIT

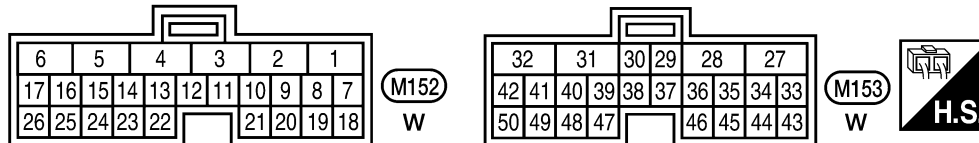

WKIA3785E

# STANDARDIZED RELAY

PFP:25230

EKS00EPO

## STANDARDIZED RELAY

### Description

### NORMAL OPEN, NORMAL CLOSED AND MIXED TYPE RELAYS

Relays can mainly be divided into three types: normal open, normal closed and mixed type relays.

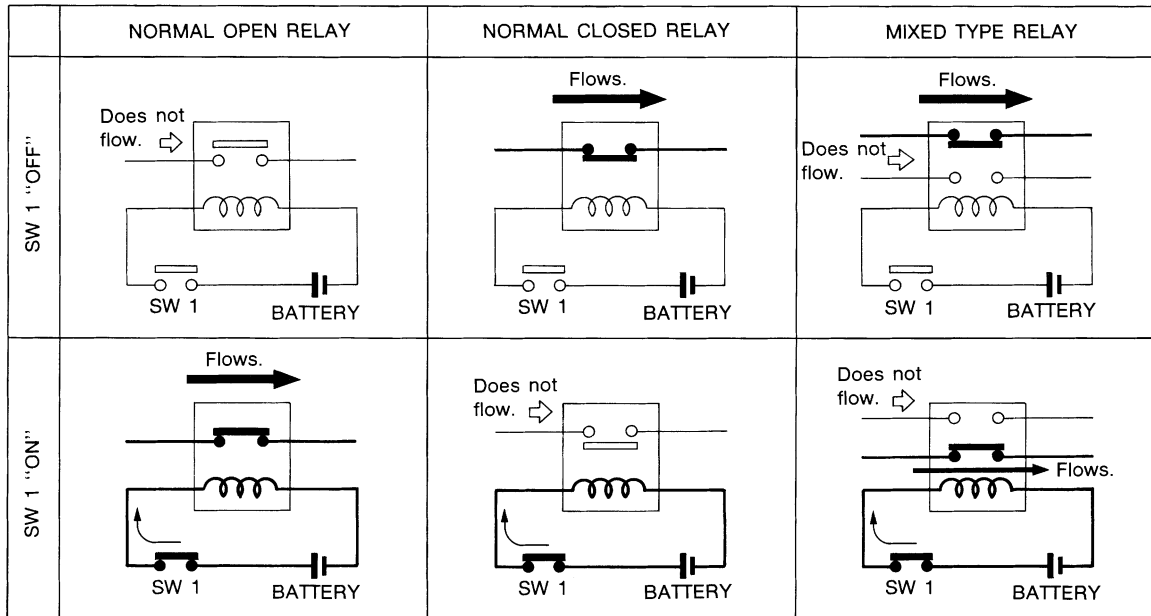

SEL881H

### TYPE OF STANDARDIZED RELAYS

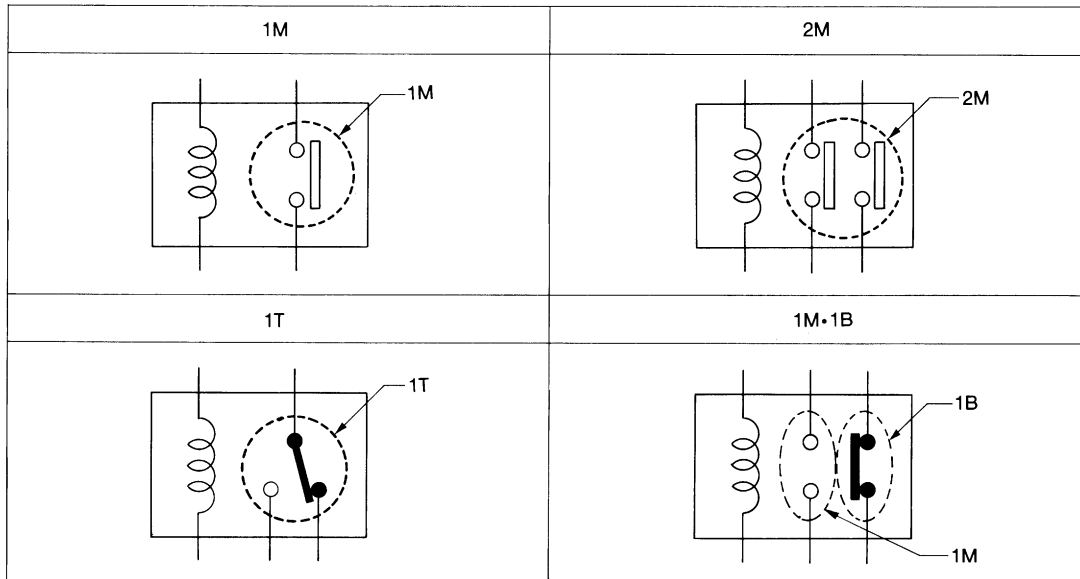

SEL882H

1M	1 Make	2M	2 Make
1T	1 Transfer	1M-1B	1 Make 1 Break

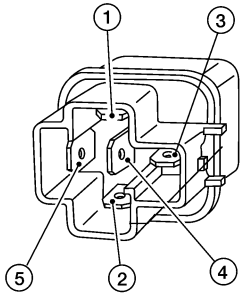
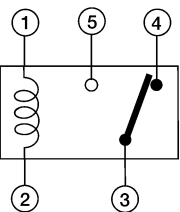
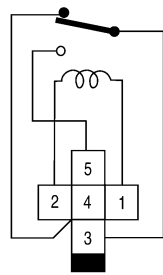
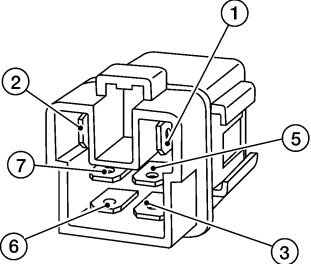
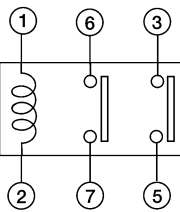
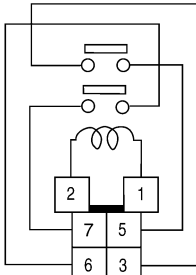
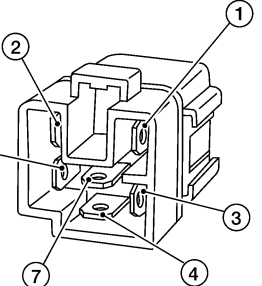
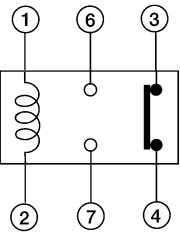
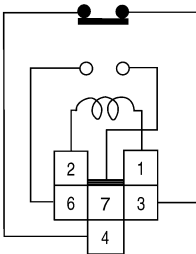
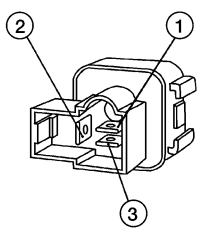
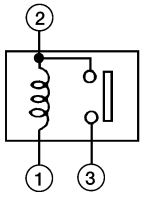
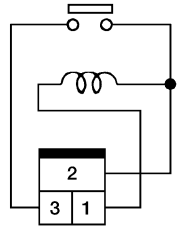
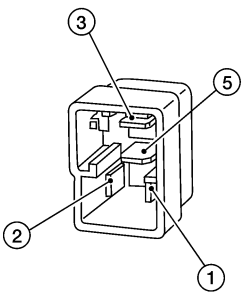
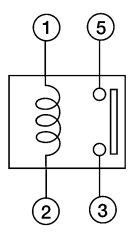
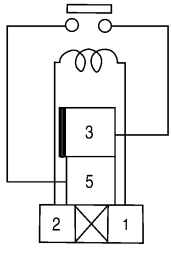

# STANDARDIZED RELAY

Type	Outer view	Circuit	Connector Symbol and connection	Case color
1T				BLACK
2M				BROWN
1M-1B				GRAY
1M				BLACK
				BLUE

The arrangement of terminal numbers on the actual relays may differ from those shown above.

WKIA0253E

A  
B  
C  
D  
E  
F  
G  
H  
I  
J  
PG  
L  
M

# SUPER MULTIPLE JUNCTION (SMJ)

## SUPER MULTIPLE JUNCTION (SMJ)

PFJ:84341

### Terminal Arrangement

EKS00EP1

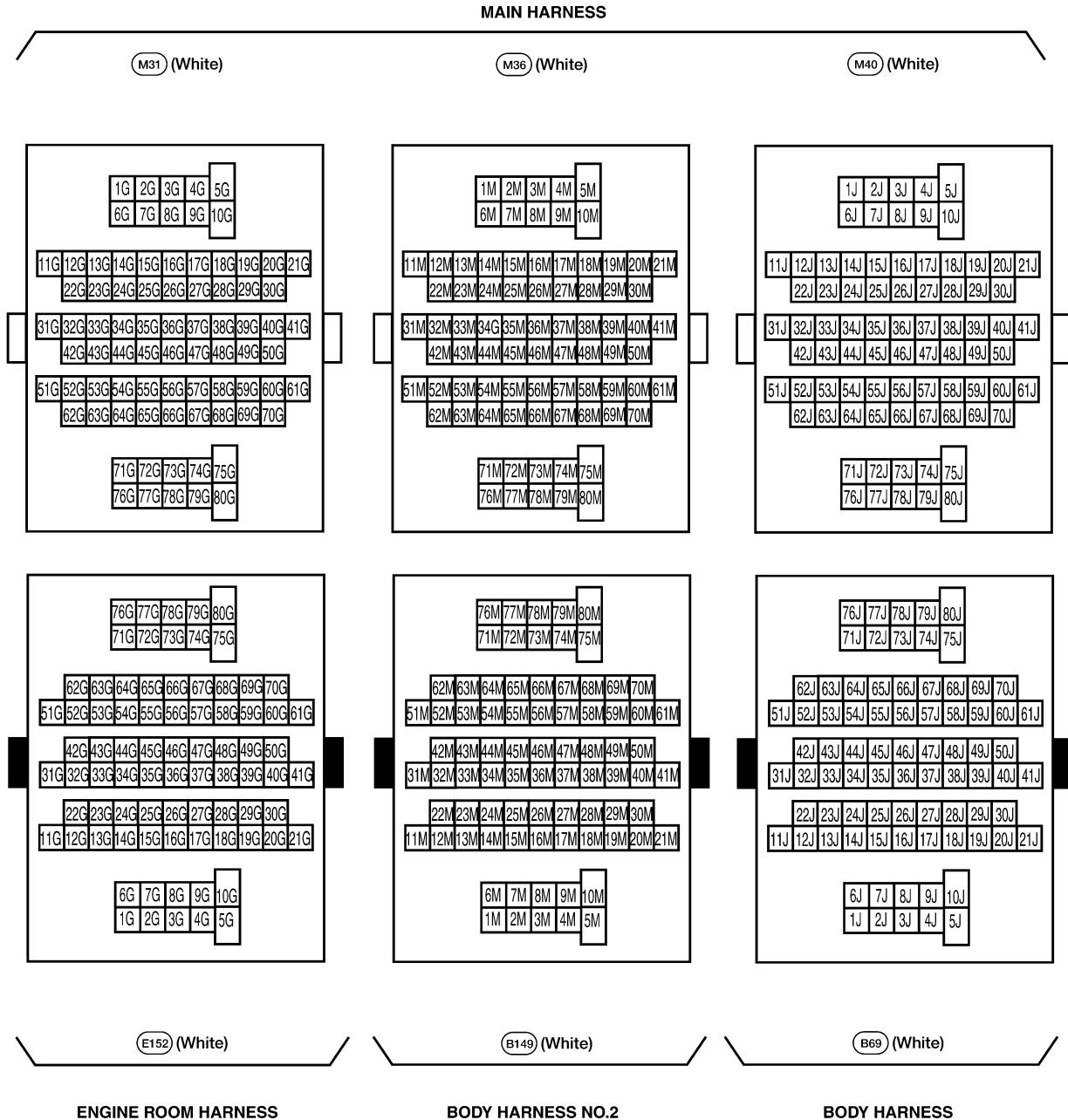

WKIA3590E

# SUPER MULTIPLE JUNCTION (SMJ)

## CHASSIS HARNESS

(C1) (Black)

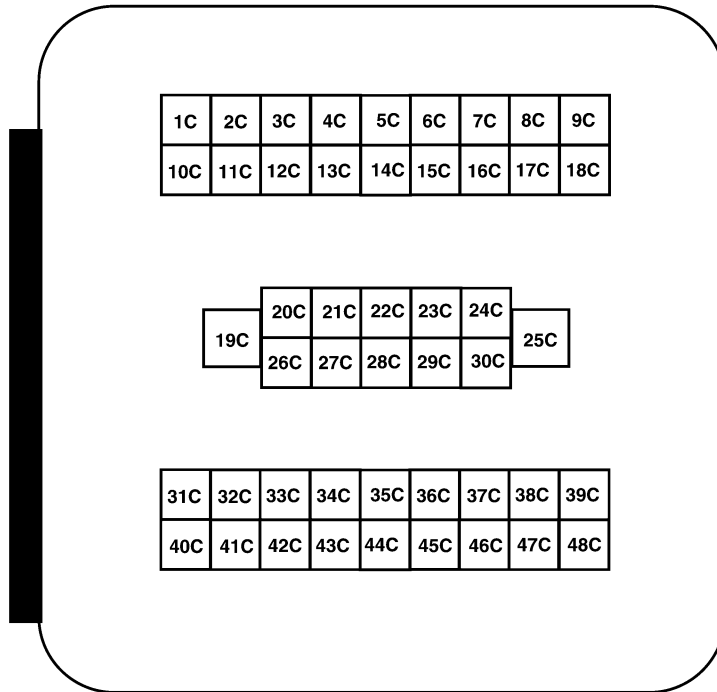
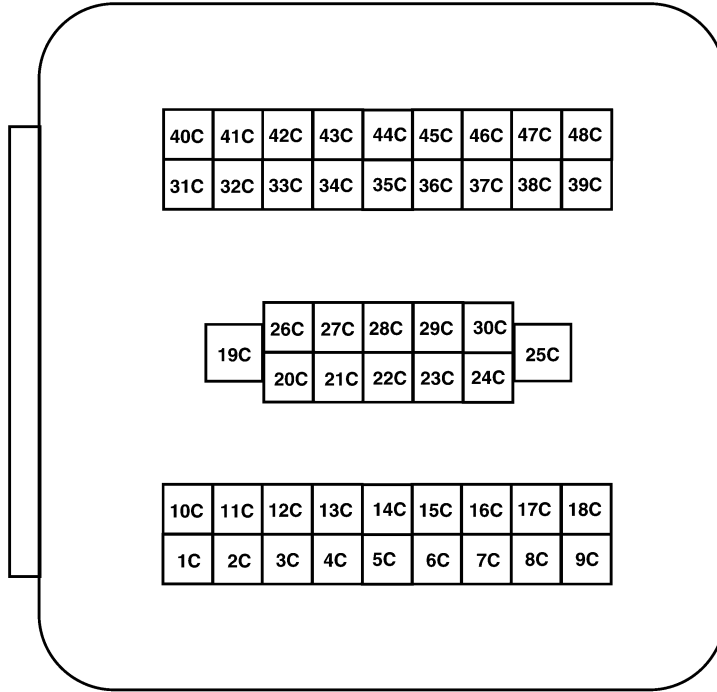

(E1) (Black)

## ENGINE ROOM HARNESS

A  
B  
C  
D  
E  
F  
G  
H  
I  
J  
PG  
L  
M

WKIA4067E

# FUSE BLOCK-JUNCTION BOX (J/B)

## FUSE BLOCK-JUNCTION BOX (J/B)

PFP:24350

### Terminal Arrangement

EKS00EP2

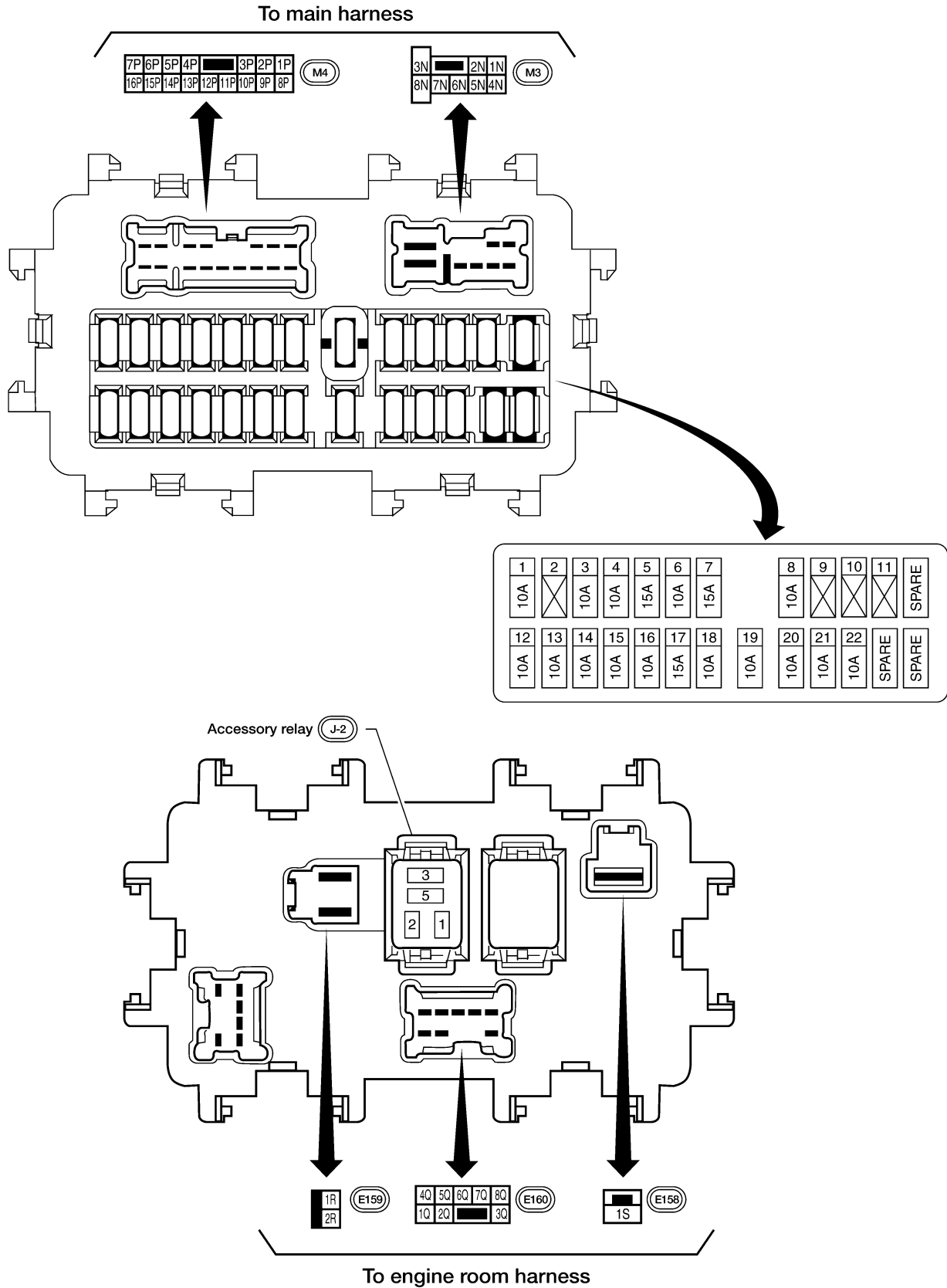

WKIA5068E

# FUSE AND FUSIBLE LINK BOX

## FUSE AND FUSIBLE LINK BOX

### Terminal Arrangement

PF24381

EKS00EP3

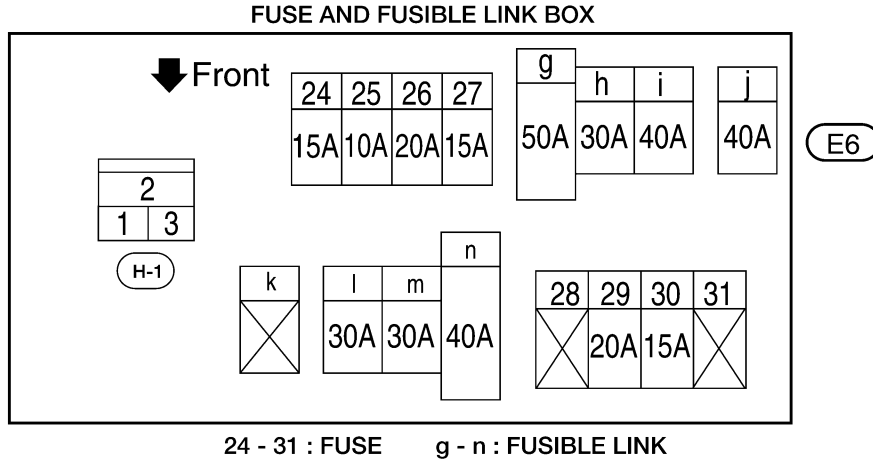

### FUSIBLE LINK BOX (BATTERY)

(E30), (E128), (E129), (E202), (F39)

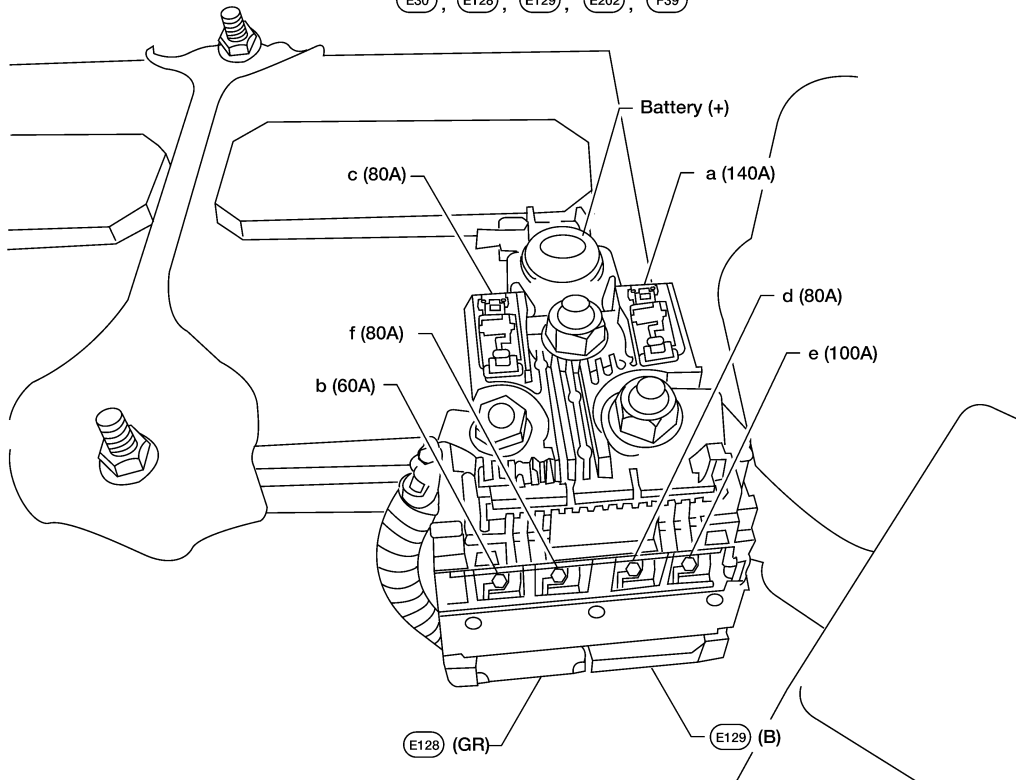

WKIA5069E

# FUSE AND RELAY BOX

PF2:24012

EKS00EP4

## FUSE AND RELAY BOX

### Terminal Arrangement

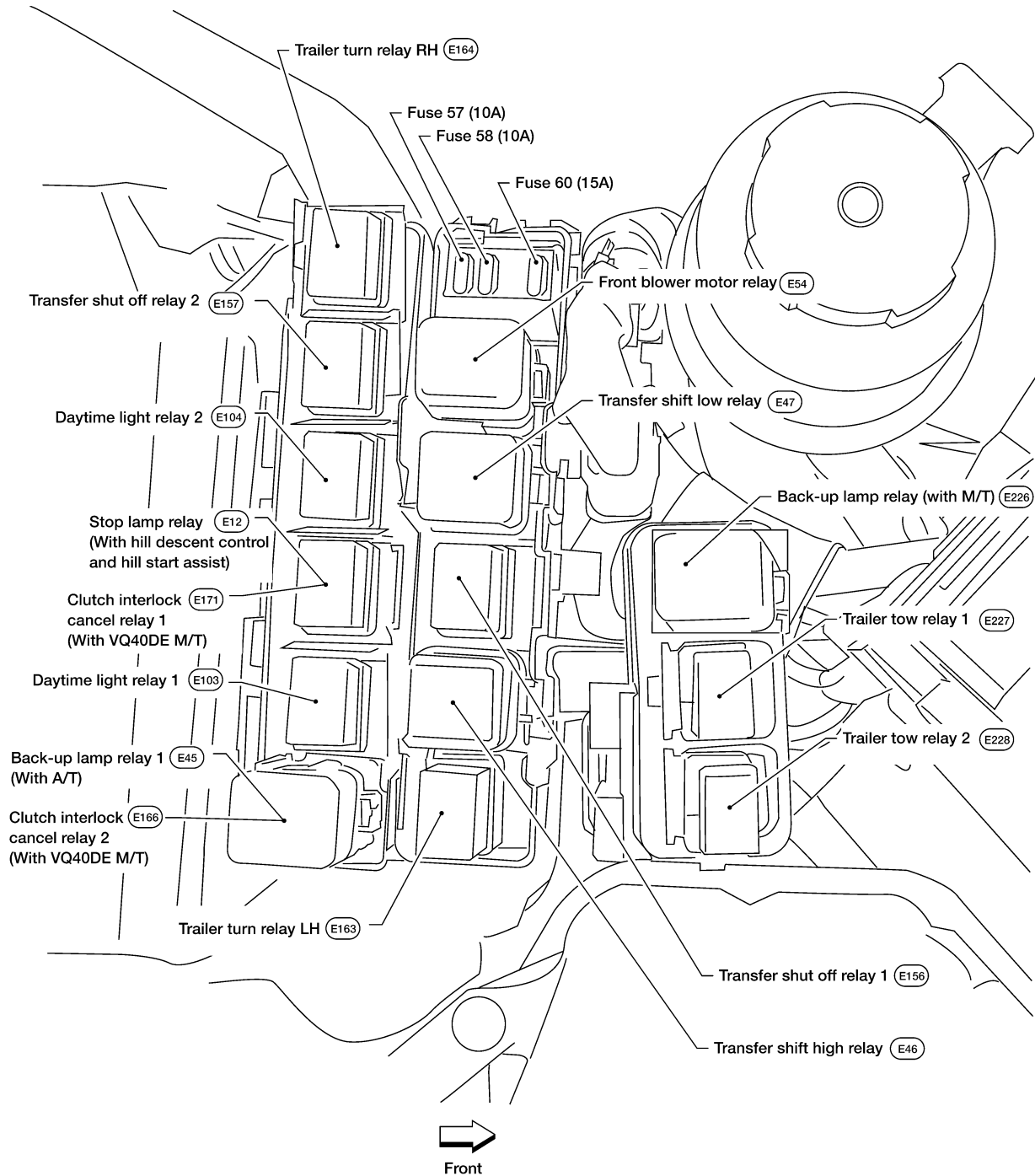

WKIA5882E