

SECTION **PB**
PARKING BRAKE SYSTEM

A
B
C
D
E
PB
G
H
I
J
K
L
M

CONTENTS

PREPARATION	2	PARKING BRAKE SHOE	6
Commercial Service Tools	2	Components	6
PARKING BRAKE SYSTEM	3	Removal and Installation	6
On-Vehicle Service	3	REMOVAL	6
LEVER STROKE	3	INSPECTION AFTER REMOVAL	7
INSPECTION	3	INSTALLATION	7
ADJUSTMENT	3	SERVICE DATA AND SPECIFICATIONS (SDS)	9
PARKING BRAKE CONTROL	4	Parking Drum Brake	9
Components	4	Parking Brake Control	9
Removal and Installation	5		
REMOVAL	5		
INSTALLATION	5		

PREPARATION

PREPARATION

PF0:0002

Commercial Service Tools

EF004ZU

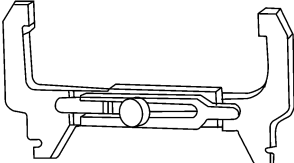
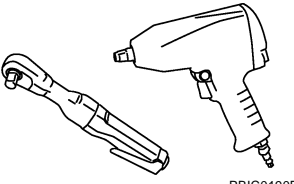
Tool number (Kent-Moore No.) Tool name		Description
— (J-21177-A) Brake drum clearance gauge	 WFIA0167E	Measuring rear rotor drum to parking brake shoe clearance
Power tool	 PBIC0190E	Loosening bolts and nuts

PARKING BRAKE SYSTEM

PARKING BRAKE SYSTEM

PF3:36010

On-Vehicle Service LEVER STROKE

EF3004ZV

- When parking brake lever is operated with the specified force, make sure the stroke is within the specified number of notches. Check by listening and counting the ratchet clicks.

Lever stroke : 6 – 8 notches [under force of 196 N (20.0 kg-f, 44.1 lb-f)]

INSPECTION

- Make sure the components are attached properly, checking for looseness or backlash.
- Check parking brake lever assembly for bends, damage and cracks, and replace if necessary.
- Check cable for wear and damage, and replace if necessary.
- Check parking brake warning lamp switch for malfunction, and replace if necessary. Refer to [DI-32, "Wiring Diagram — WARN —"](#).

ADJUSTMENT

- Remove rear half of the center console. Refer to [IP-14, "CENTER CONSOLE"](#).
- Rotate adjusting nut and loosen cable until tension is sufficiently released.

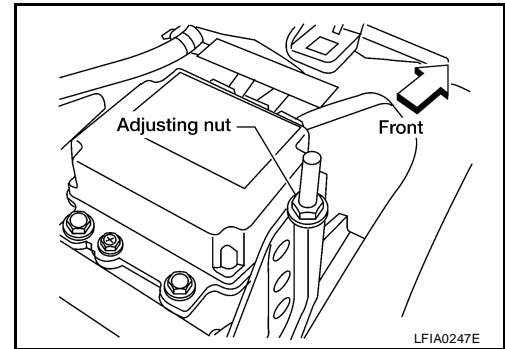

- Remove the wheel and tire using power tool.
- Remove the rotor and measure inner diameter at widest point using Tool.

Tool number : — (J-21177-A)

- Transfer measurement less 0.6 mm to the parking brake shoes and adjust accordingly.
- Using wheel nuts, secure the disc to the hub to prevent it from tilting.
- Rotate disc rotor to make sure there is no drag.
- Adjust cable as follows:
 - Operate parking brake lever 10 or more times with a force of 490 N (50 kg-f, 110 lb-f).
 - Rotate adjusting nut to adjust lever stroke to specification.

Lever stroke : 6 – 8 notches [under force of 196 N (20.0 kg-f, 44.1 lb-f)]

- With parking brake lever completely disengaged, make sure there is no drag on the parking brake.

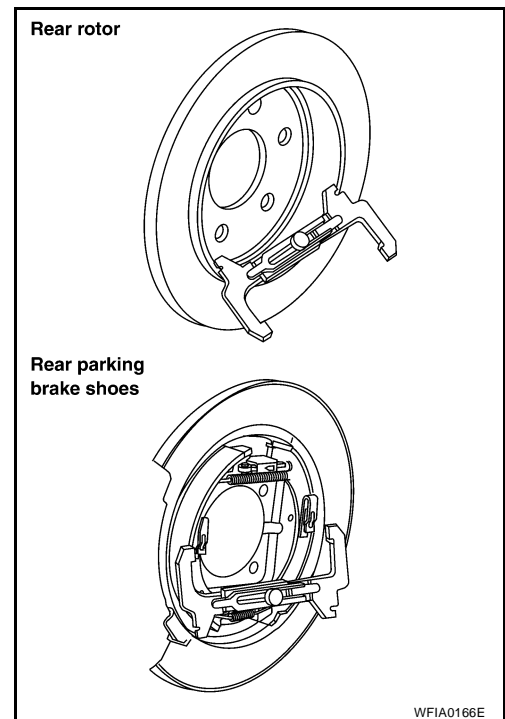

PARKING BRAKE CONTROL

PARKING BRAKE CONTROL

PF0:36010

Components

EF004ZW

SEC. 443

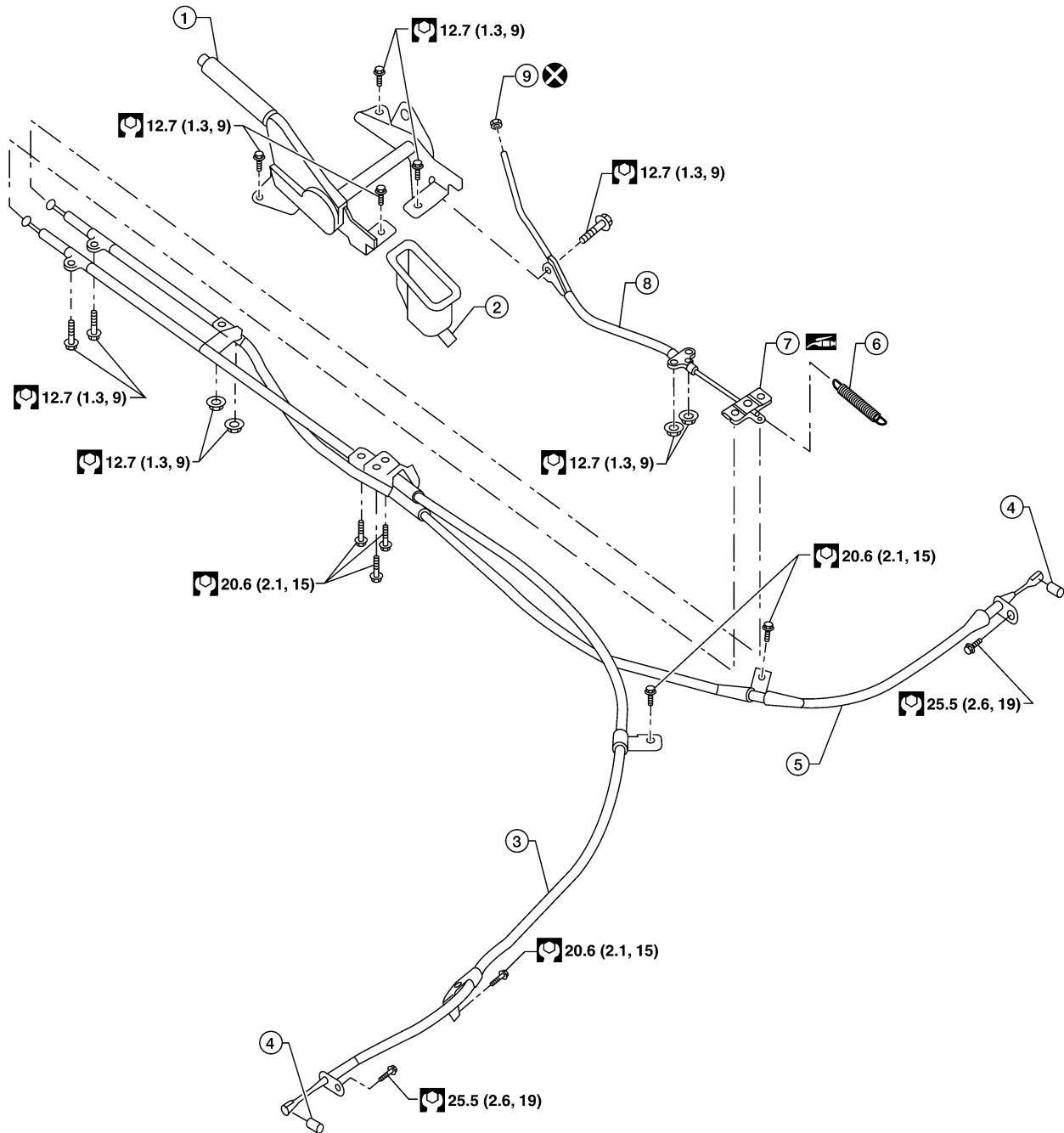

- : Apply multi-purpose grease.
Refer to MA section.
- : N·m (kg·m, ft·lb)
- : N·m (kg·m, in·lb)
- : Always replace after every disassembly.

- | | | |
|---------------------------|------------------------|--------------------|
| 1. Control lever assembly | 2. Front cable grommet | 3. Left rear cable |
| 4. Pin | 5. Right rear cable | 6. Return spring |
| 7. Equalizer | 8. Front cable | 9. Adjusting nut |

LF1A0245E

PARKING BRAKE CONTROL

EFS004ZX

Removal and Installation

REMOVAL

1. Disconnect return spring from equalizer. A
 2. Remove right and left rear cables from equalizer. B
 3. Remove front parking brake cable bolts from under vehicle. B
 4. Remove rear half of center console. Refer to [IP-14, "CENTER CONSOLE"](#). C
 5. Remove four control lever assembly bolts, then remove control lever assembly. C
 6. Remove the front cable grommet and cover from control lever assembly. D
 7. Remove front cable to control lever assembly bolt. D
 8. Remove the control lever assembly adjusting nut, then remove front cable. D
- CAUTION:**
Do not reuse adjusting nut after removing it.
9. Remove the rear disc rotors. Refer to [BR-23, "Removal and Installation of Brake Caliper Assembly and Disc Rotor"](#). E
 10. Remove parking brake shoes, and remove rear cable from toggle lever. Refer to [PB-6, "Removal and Installation"](#). PB
 11. Remove right and left rear cable bolts and nuts, then remove right and left rear cables. PB

INSTALLATION

- Installation is in the reverse order of removal. G
- CAUTION:**
- **Do not reuse adjusting nut after removal.** H
 - **Install the control lever assembly bolts in a criss-cross pattern.** H
- Adjust parking brake. Refer to [PB-3, "ADJUSTMENT"](#). I
- J
- K
- L
- M

PARKING BRAKE SHOE

PF0:44060

PARKING BRAKE SHOE

Components

EFS005SN

SEC. 441

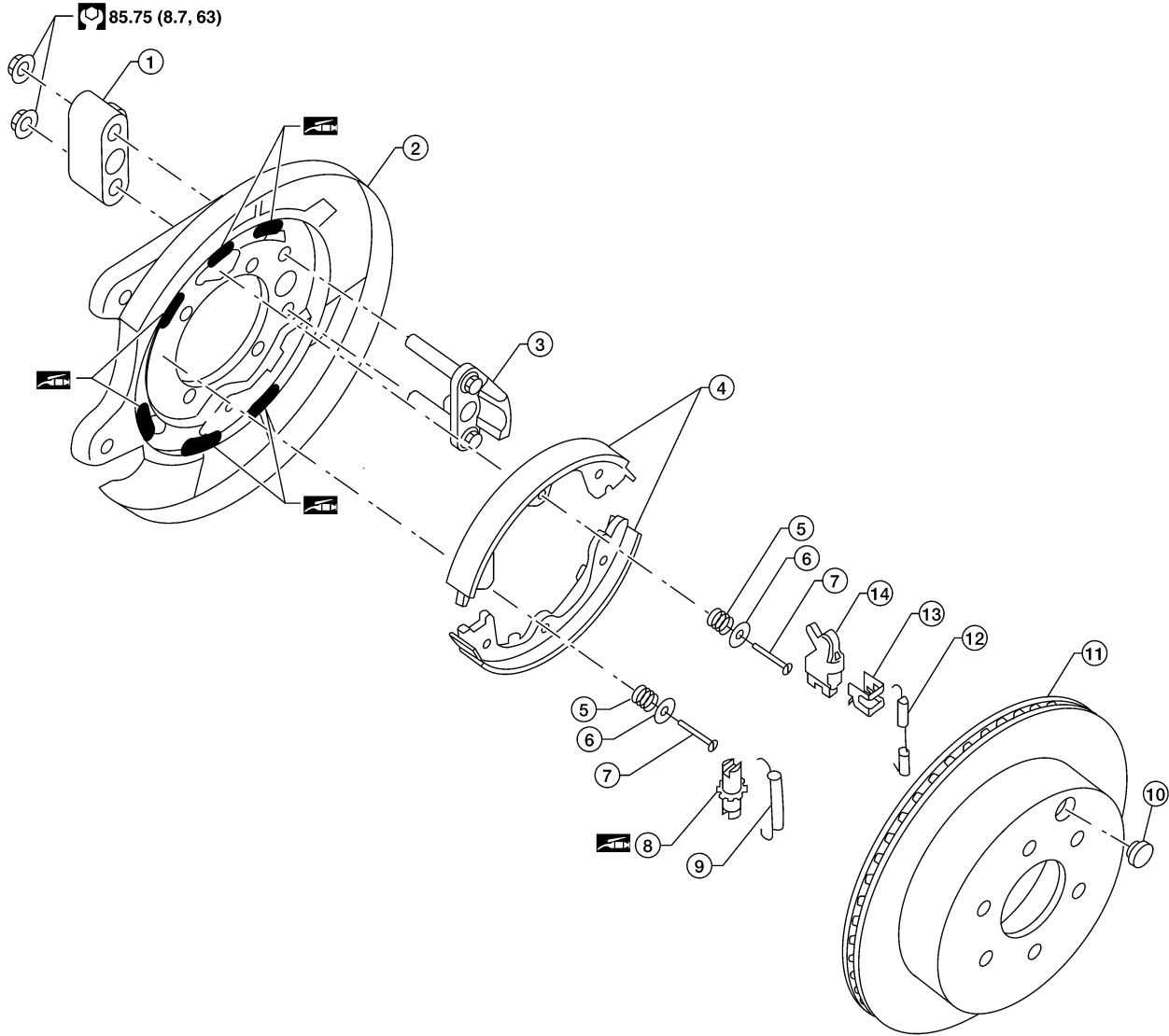

 : N·m (kg·m, ft·lb)

 : Apply PBC (Poly Butyl Cuprysil) grease or equivalent. Refer to MA section.

- | | | |
|--------------------------|--------------------------|-------------------------|
| 1. Anchor block | 2. Back plate | 3. Anchor |
| 4. Shoes | 5. Shoe hold-down spring | 6. Retainer |
| 7. Shoe hold-down pin | 8. Adjuster | 9. Rear return spring |
| 10. Adjuster access plug | 11. Disc rotor | 12. Front return spring |
| 13. Pin retainer | 14. Toggle lever | |

LF1A0246E

Removal and Installation

REMOVAL

EFS004ZY

WARNING:

Clean the brakes with a vacuum dust collector to minimize the hazard of airborne particles or other materials.

PARKING BRAKE SHOE

NOTE:

Remove the disc rotor only with the parking brake lever completely disengaged.

1. Remove the rear disc rotor. Refer to [BR-23, "Removal and Installation of Brake Caliper Assembly and Disc Rotor"](#).
2. Remove the return springs.
3. Remove the adjuster.
4. Remove the retainers, anti-rattle pins and shoes.
5. Remove pin retainer, then disconnect the parking brake cable from the toggle lever.
6. Remove back plate.

INSPECTION AFTER REMOVAL

Lining Thickness Inspection

- Check thickness of lining.

Standard thickness "A" : 5.15 ± 0.25 mm
(0.203 ± 0.010 in)

Repair limit thickness "A" : 0.5 mm (0.020 in)

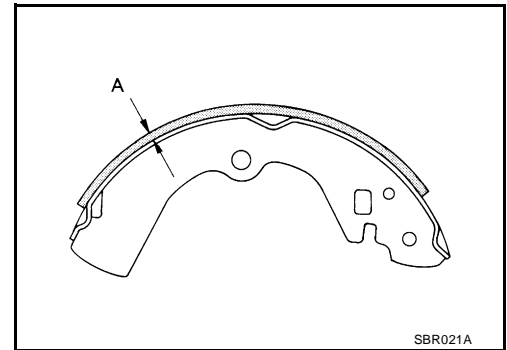

Drum Inner Diameter Inspection

- Check drum inner diameter.

Standard inner diameter : 205 ± 0.13 mm
(8.07 ± 0.01 in)

Maximum inner diameter : 205.7 mm (8.10 in)

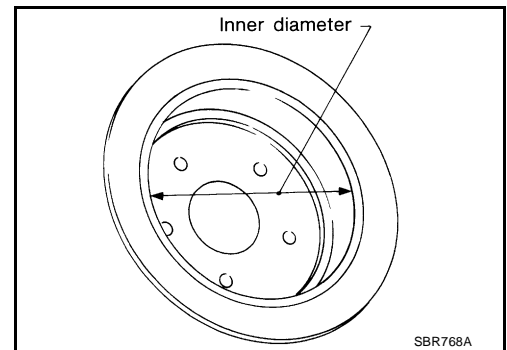

Other Inspections

- Check shoe sliding surface for excessive wear and damage.
- Check anti-rattle pin for excessive wear and corrosion.
- Check return spring for sagging.
- Check adjuster for rough operation.
- When disassembling adjuster, apply PBC (Poly Butyl Cuprysil) grease or equivalent to the adjuster threads. Refer to [MA-11, "RECOMMENDED FLUIDS AND LUBRICANTS"](#).
- Check either visually or with a vernier caliper to see if there is any excessive wear, cracks, or damage inside drum.

INSTALLATION

Installation is in the reverse order of removal.

- Apply brake grease to the specified points during assembly. Refer to [PB-6, "Components"](#).

PARKING BRAKE SHOE

- Install adjuster so that threaded part expands when rotating it in the direction shown by the arrow.
- Shorten adjuster by rotating it in the opposite direction as shown by the arrow.

NOTE:

After replacing brake shoes or disc rotors, or if parking brake does not function well, perform break-in operation as follows.

1. Adjust parking brake lever stroke. Refer to [PB-3, "ADJUSTMENT"](#).

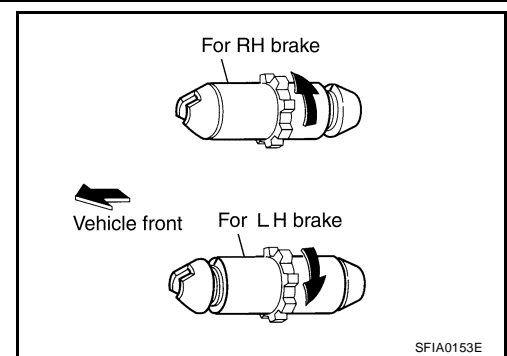

2. Perform parking brake burnishing operation by driving the vehicle forward under the following conditions:
 - **Vehicle speed 40 km/h (25 MPH) set (forward)**
 - **Parking brake operating force 196 N (20.0 kg-f, 44.1 lb-f) set**
 - **Apply time 30 sec.**

CAUTION:

- **To prevent lining from getting too hot, allow a cool off period of approximately 5 minutes after every break-in operation.**
 - **Do not perform excessive break-in operations, because it may cause uneven or early wear of lining.**
3. After burnishing operation, check parking brake lever stroke. Readjust if it is now longer than the specified stroke. Refer to [PB-3, "ADJUSTMENT"](#).

SERVICE DATA AND SPECIFICATIONS (SDS)

SERVICE DATA AND SPECIFICATIONS (SDS)

PFP:00030

Parking Drum Brake

EFS004ZZ

Unit: mm (in)

Type	Drum	
Brake lining	Standard thickness (new)	5.15 ± 0.25 (0.203 ± 0.010)
	Wear limit thickness	0.5 (0.020)
Drum inner diameter (disc)	Standard inner diameter (new)	205 ± 0.13 (8.07 ± 0.01)
	Wear limit of inner diameter	205.7 (8.10)

Parking Brake Control

EFS00500

Control type	Control lever
Number of notches [under force of 196 N (20.0 kg-f, 44.1 lb-f)]	6 – 8 notches
Number of notches when warning lamp switch comes on	1 notch

A
B
C
D
E
G
H
I
J
K
L
M

PB

SERVICE DATA AND SPECIFICATIONS (SDS)
