

PRECAUTIONS

[QR]

PFP:00001

EBS00NHH

PRECAUTIONS

Precautions for Liquid Gasket REMOVAL OF LIQUID GASKET SEALING

- After removing nuts and bolts, separate the mating surface and remove old liquid gasket sealing using Tool.

Tool number : KV10111100 (J-37228)

CAUTION:

Be careful not to damage the mating surfaces.

- Tap seal cutter to insert it, and then slide it by tapping on the side as shown.
- In areas where Tool is difficult to use, use plastic hammer to lightly tap the parts, to remove it.

CAUTION:

If for some unavoidable reason tool such as screwdriver is used, be careful not to damage the mating surfaces.

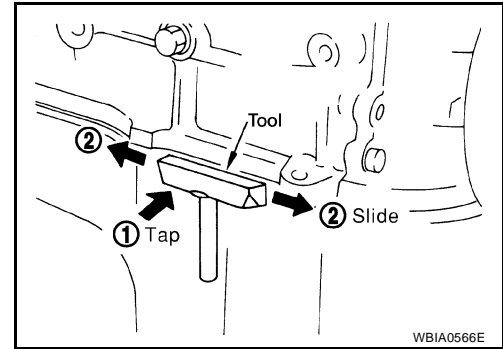

LIQUID GASKET APPLICATION PROCEDURE

- Using scraper, remove old liquid gasket adhering to the gasket application surface and the mating surface.
 - Remove liquid gasket completely from the groove of the gasket application surface, bolts, and bolt holes.
- Thoroughly clean the mating surfaces and remove adhering moisture, grease and foreign materials.

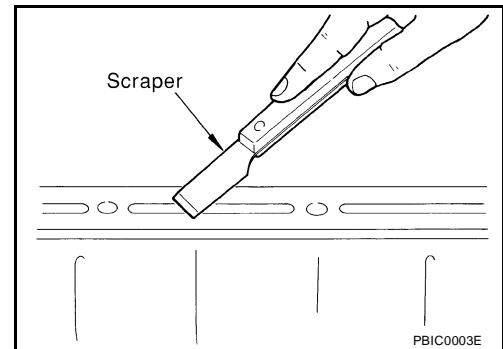

- Attach liquid gasket tube to Tool.

Tool number : WS39930000 (—)

Use Genuine RTV Silicone Sealant or equivalent. Refer to GI-47, "Recommended Chemical Products and Sealants".

- Apply liquid gasket without breaks to the specified location with the specified dimensions.
 - If there is a groove for liquid gasket application, apply liquid gasket to the groove.

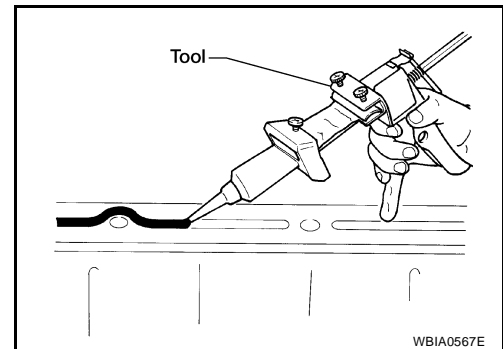

- As for bolt holes, normally apply liquid gasket inside the holes. Occasionally, it should be applied outside the holes. Make sure to read the text of this manual.
- Within five minutes of liquid gasket application, install the mating component.
- If liquid gasket protrudes, wipe it off immediately.
- Do not retighten nuts or bolts after the installation.
- After 30 minutes or more have passed from the installation, fill engine oil and engine coolant.

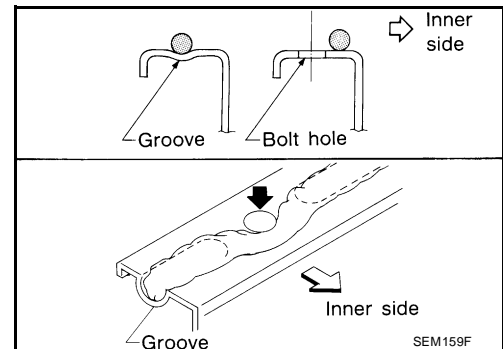

CAUTION:

If there are specific instructions in this manual, observe them.

PREPARATION

[QR]

PFP:00002

EBS00NH5

PREPARATION

Special Service Tools

The actual shapes of Kent-Moore tools may differ from those of special service tools illustrated here.

Tool number (Kent-Moore No.) Tool name	Description
KV10111100 (J-37228) Seal cutter	Removing oil pan and front cover, etc.
ST25051001 (J-25695-1) Oil pressure gauge	Measuring oil pressure Maximum measuring range: 2,452 kPa (25 kg/cm² , 356 psi)
ST25052000 (J-25695-2) Hose	Adapting oil pressure gauge to oil pan (upper)
KV10115801 (J-38956) Oil filter wrench	Removing and installing oil filter a: 64.3 mm (2.531 in)
WS39930000 (—) Tube presser	Pressing the tube of liquid gasket

A

LU

C

D

E

F

G

H

I

J

K

L

M

LUBRICATION SYSTEM

PF15010

Lubrication Circuit

EBS00NH6

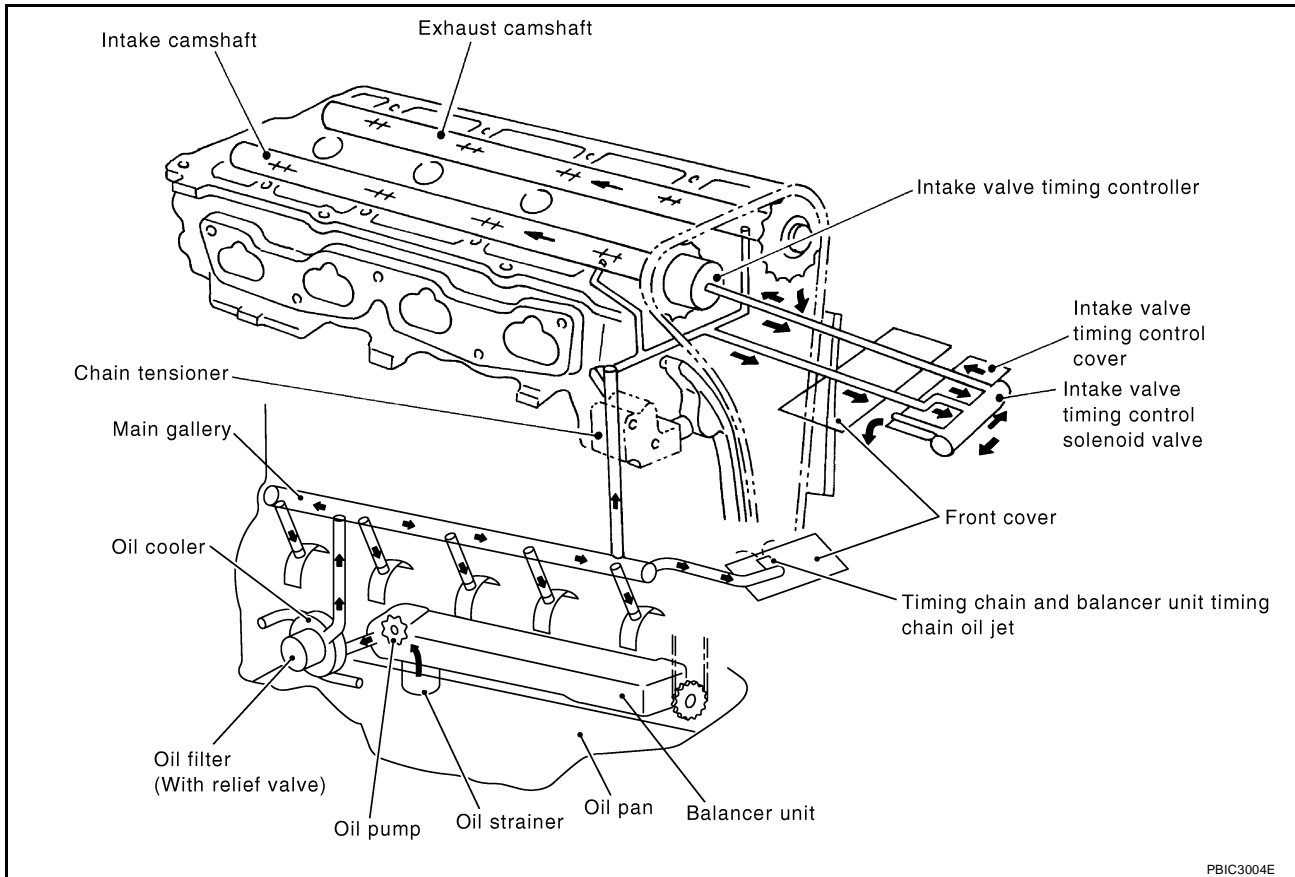

PBIC3004E

LUBRICATION SYSTEM

[QR]

System Chart

EBS00NH7

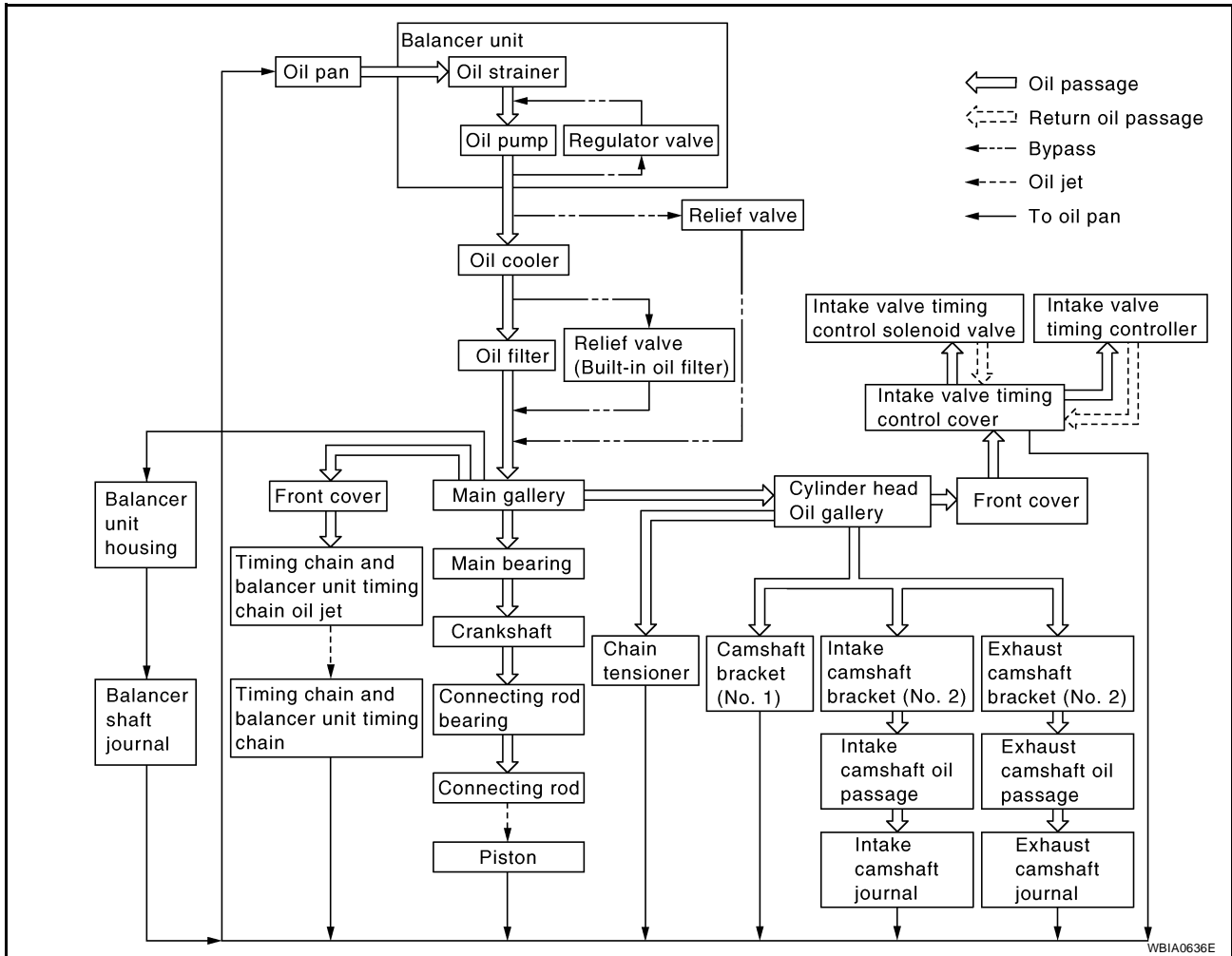

A
 LU
 C
 D
 E
 F
 G
 H
 I
 J
 K
 L
 M

ENGINE OIL

Inspection ENGINE OIL LEVEL

NOTE:

Before starting the engine, put the vehicle horizontally and check the engine oil level. If the engine is already started, stop it and allow 10 minutes before checking.

1. Pull out oil level gauge and wipe it clean.
2. Insert oil level gauge and make sure the engine oil level is within the range as shown.
3. If it is out of range, adjust it.

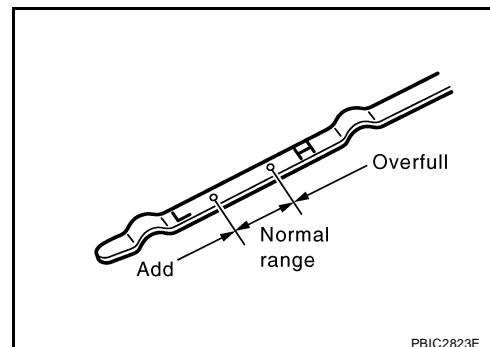

ENGINE OIL APPEARANCE

- Check engine oil for white milky or excessive contamination.
- If engine oil becomes milky, it is highly probable that it is contaminated with engine coolant. Repair or replace damaged parts.

ENGINE OIL LEAKAGE

Check for engine oil leakage around the following area.

- Oil pan
- Oil pan drain plug
- Oil pressure sensor
- Oil filter
- Oil cooler
- Intake valve timing control cover and intake valve timing control solenoid valve
- Front cover
- Mating surface between cylinder block and lower cylinder block
- Mating surface between cylinder block and cylinder head
- Mating surface between cylinder head and rocker cover
- Crankshaft oil seals (front and rear)

OIL PRESSURE CHECK

WARNING:

- Be careful not to burn yourself, as engine oil may be hot.
 - Engine oil pressure check should be in "Parking position" (A/T models) or "Neutral position" (M/T models), and should apply parking brake securely.
1. Check the engine oil level. Refer to [LU-6, "ENGINE OIL LEVEL"](#) .
 2. Remove engine undercover.
 3. Disconnect oil pressure sensor harness connector, and remove oil pressure sensor using a suitable tool. Refer to [EM-75, "CYLINDER BLOCK"](#) .

CAUTION:

Do not drop or shock oil pressure sensor.

ENGINE OIL

[QR]

4. Install Tools.

Tool numbers : ST25051001 (J-25695-1)
: ST25052000 (J-25695-2)

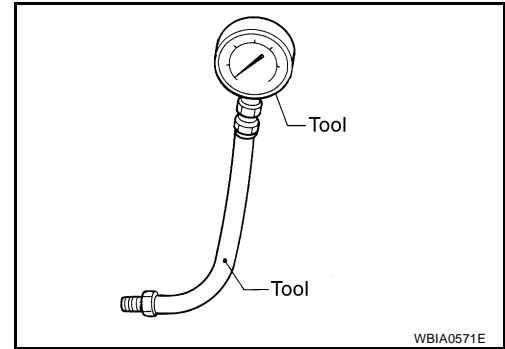

5. Start the engine and warm it up to normal operating temperature.
6. Check oil pressure with the engine running under no-load.

NOTE:

When engine oil temperature is low, engine oil pressure becomes high.

Engine oil pressure [Engine oil temperature at 80°C (176°F)]

Engine speed rpm	Approximate discharge pressure kPa (kg/cm ² , psi)
Idle speed	More than 98 (1.0, 14)
2,000	More than 294 (3.0, 43)

If difference is extreme, check for oil leakage in oil passages and oil pump (built in balancer unit) malfunction.

CAUTION:

It is impossible to replace or adjust oil pump because oil pump is manufactured with balancer unit. If any malfunction is found on oil pump, replace balancer unit as an assembly.

7. After the inspections, install oil pressure sensor as follows:
 - a. Remove old liquid gasket adhering to oil pressure sensor and the engine.
 - b. Apply liquid gasket and tighten oil pressure sensor to the specification.
Use Genuine RTV Silicone Sealant or equivalent. Refer to [GI-47, "Recommended Chemical Products and Sealants"](#).

Oil pressure sensor torque : 14.8 N-m (1.5 kg-m, 11 ft-lb)

- c. After warming up the engine, make sure there is no leaks of engine oil with running the engine.

Changing Engine Oil

WARNING:

- Be careful not to burn yourself, as engine oil may be hot.
 - Prolonged and repeated contact with used engine oil may cause skin cancer; try to avoid direct skin contact with used engine oil. If skin contact is made, wash thoroughly with soap or hand cleaner as soon as possible.
1. Warm up the engine, put the vehicle horizontally and check for oil leakage from the engine components. Refer to [LU-6, "ENGINE OIL LEAKAGE"](#).
 2. Stop the engine and wait for 10 minutes.
 3. Loosen oil filler cap and then remove drain plug.
 4. Drain engine oil.
 5. Install drain plug with new washer.

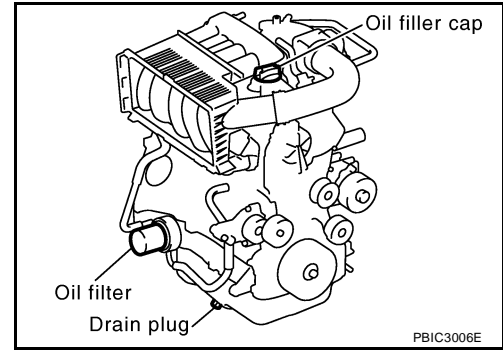

CAUTION:

Be sure to clean drain plug and install with new washer.

Oil pan drain plug: : 34.3 N·m (3.5 kg-m, 25 ft-lb)

6. Refill with new engine oil.
Engine oil specification and viscosity:
 Refer to [MA-11, "QR25DE"](#).

Engine oil capacity (Approximate):

Unit: ℓ (US qt, Imp qt)

Drain and refill	With oil filter change	4.9 (5-1/8, 4-3/8)
	Without oil filter change	4.6 (4-7/8, 4)
Dry engine (Overhaul)		5.0 (5 1/4, 4 3/8)

CAUTION:

- The refill capacity depends on the engine oil temperature and drain time. Use these specifications for reference only.
 - Always use oil level gauge to determine the proper amount of engine oil in the engine.
7. Warm up the engine and check area around drain plug and oil filter for oil leakage.
 8. Stop the engine and wait for 10 minutes.
 9. Check the engine oil level. Refer to [LU-6, "ENGINE OIL LEVEL"](#).

OIL FILTER

Changing Oil Filter

1. Remove the oil filter using Tool as shown.

Tool number : KV10115801 (J-38956)

WARNING:

Be careful not to get burned as the engine and engine oil are hot.

CAUTION:

- The oil filter contains an internal relief valve. Use a Genuine NISSAN oil filter.
- When removing the oil filter, position a shop cloth to absorb any engine oil leakage or spillage.
- Do not allow the engine oil to spill on the drive belts.
- Completely wipe off any engine oil that spills on the engine or on the vehicle.

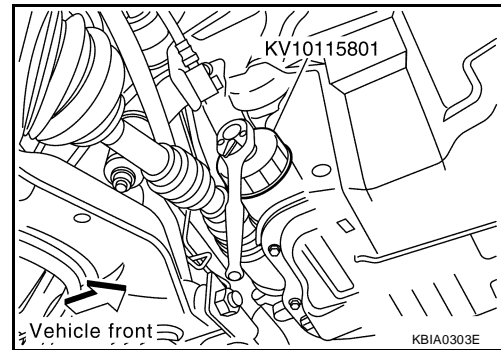

2. Remove any foreign materials adhering to the oil filter installation surface.
3. Apply new engine oil to the oil seal contact surface of new oil filter as shown.

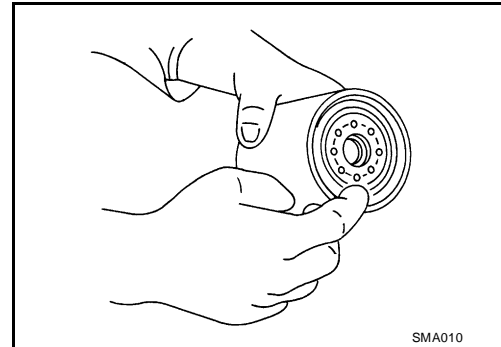

4. Screw on the oil filter manually until a slight resistance is felt, then tighten the oil filter an additional 2/3 turn as shown. Or tighten to specification.

Oil filter : Refer to [EM-75, "CYLINDER BLOCK"](#) .

5. Check the engine oil level using the dipstick as shown, adjust the engine oil level as necessary.
6. Start the engine and check for engine oil leaks, correct as necessary.
7. Stop the engine and wait for 10 minutes.
8. Check the engine oil level using the dipstick and adjust the engine oil level as necessary.

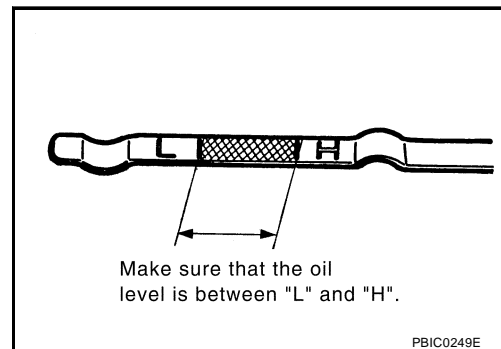

OIL COOLER

Removal and Installation

EBS00NHB

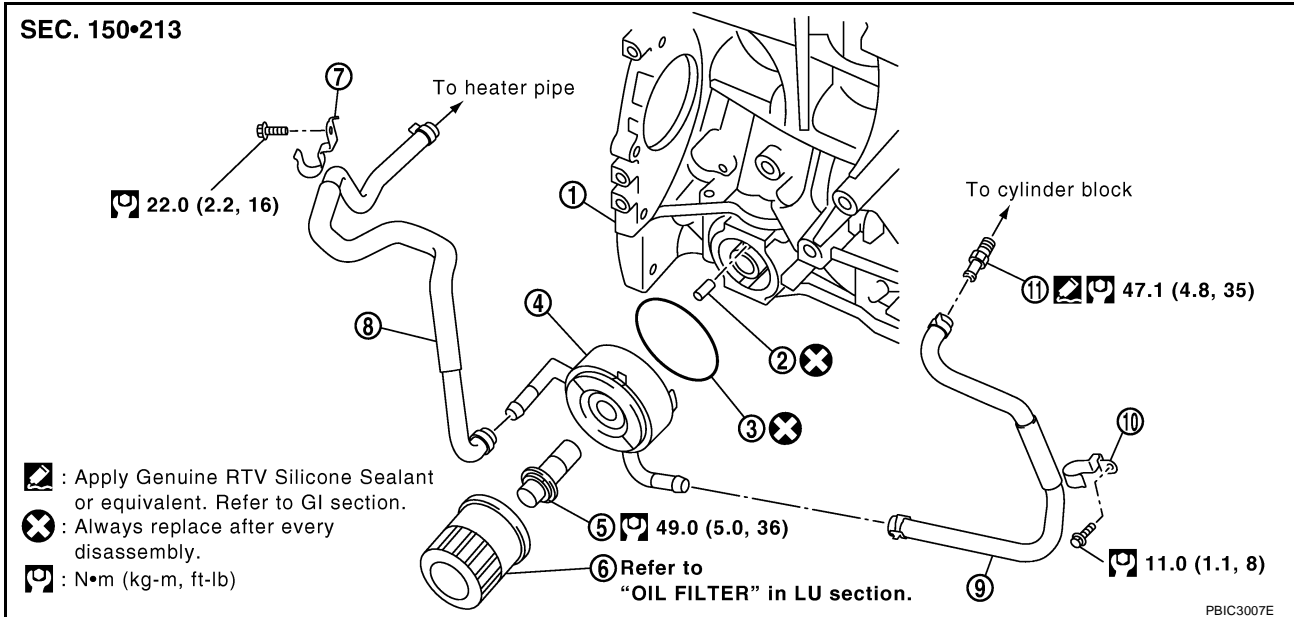

- | | | |
|-------------------|---------------------|---------------|
| 1. Cylinder block | 2. Relief valve | 3. O-ring |
| 4. Oil cooler | 5. Connector bolt | 6. Oil filter |
| 7. Bracket | 8. Water hose | 9. Water hose |
| 10. Bracket | 11. Water connector | |

WARNING:

- Be careful not to get burned when engine coolant and engine oil may be hot.

CAUTION:

- When removing oil cooler and oil cooler bracket, prepare a shop cloth to absorb any engine oil leakage or spillage.
- Completely wipe off any engine oil that adhere to the engine and the vehicle.

REMOVAL

1. Drain engine coolant from radiator drain plug at the bottom of radiator and from water drain plug on cylinder block. Refer to [CO-11, "DRAINING ENGINE COOLANT"](#) and [EM-75, "CYLINDER BLOCK"](#).

NOTE:

Perform this step when removing water hoses.

2. Remove oil filter. Refer to [LU-9, "OIL FILTER"](#).

CAUTION:

Do not spill engine oil on drive belts.

3. Disconnect water hoses from oil cooler.

- When removing oil cooler only, pinching water hoses near oil cooler to prevent engine coolant spilling.

CAUTION:

- Perform this step when engine is cold.
- Do not spill engine coolant on drive belts.

4. Remove connector bolt, and remove oil cooler.

CAUTION:

Do not spill engine oil to rubber parts such as drive belts and engine mounting insulator.

5. Remove water hoses, brackets and water connector, as necessary.

INSPECTION AFTER REMOVAL

Oil Cooler

- Check oil cooler for cracks.
- Check oil cooler for clogging by blowing through engine coolant inlet.

If necessary, replace oil cooler.

Relief Valve

Check relief valve for movement, cracks and breaks by pushing the ball. If replacement is necessary, remove valve by prying it out with a suitable tool. Install the new valve in place by tapping it.

INSTALLATION

Note the following, and install in the reverse order of removal.

- Make sure that no foreign objects are adhering to the installation planes of oil cooler and lower cylinder block.
- Align cutout on oil cooler with protrusion on lower cylinder block side, and tighten connector bolt.

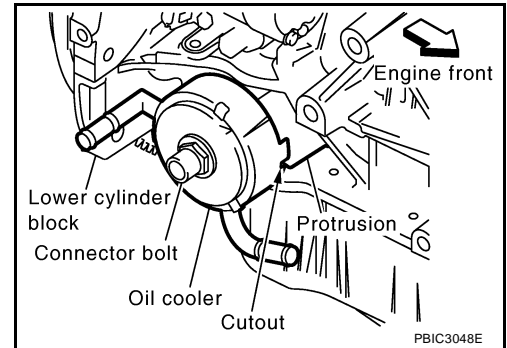

INSPECTION AFTER INSTALLATION

1. Check the engine oil level and the engine coolant level, and adjust the levels. Refer to [LU-6, "ENGINE OIL LEVEL"](#) and [CO-12, "REFILLING ENGINE COOLANT"](#) .
2. Start the engine, and make sure there is no leaks of engine oil or engine coolant.
3. Stop the engine and wait for 10 minutes.
4. Check the engine oil level and the engine coolant level again. Refer to [LU-6, "ENGINE OIL LEVEL"](#) and [CO-12, "REFILLING ENGINE COOLANT"](#) .

SERVICE DATA AND SPECIFICATIONS (SDS)

[QR]

SERVICE DATA AND SPECIFICATIONS (SDS)

PF0:00030

Standard and Limit OIL PRESSURE

EBS00NHC

Engine speed rpm	Approximate discharge pressure* kPa (kg/cm ² , psi)
Idle speed	More than 98 (1.0, 14)
2,000	More than 294 (3.0, 43)

*: Engine oil temperature at 80° (176°F)

ENGINE OIL CAPACITY (APPROXIMATE)

Unit: ℓ (US qt, Imp qt)

Drain and refill	With oil filter change	4.9 (5-1/8, 4-3/8)
	Without oil filter change	4.6 (4-7/8, 4)
Dry engine (Overhaul)		5.0 (5 1/4, 4 3/8)

PRECAUTIONS

PFP:00001

Precautions for Supplemental Restraint System (SRS) “AIR BAG” and “SEAT BELT PRE-TENSIONER”

EBS00YSG

The Supplemental Restraint System such as “AIR BAG” and “SEAT BELT PRE-TENSIONER”, used along with a front seat belt, helps to reduce the risk or severity of injury to the driver and front passenger for certain types of collision. This system includes seat belt switch inputs and dual stage front air bag modules. The SRS system uses the seat belt switches to determine the front air bag deployment, and may only deploy one front air bag, depending on the severity of a collision and whether the front occupants are belted or unbelted. Information necessary to service the system safely is included in the SRS and SB section of this Service Manual.

WARNING:

- To avoid rendering the SRS inoperative, which could increase the risk of personal injury or death in the event of a collision which would result in air bag inflation, all maintenance must be performed by an authorized NISSAN/INFINITI dealer.
- Improper maintenance, including incorrect removal and installation of the SRS, can lead to personal injury caused by unintentional activation of the system. For removal of Spiral Cable and Air Bag Module, see the SRS section.
- Do not use electrical test equipment on any circuit related to the SRS unless instructed to in this Service Manual. SRS wiring harnesses can be identified by yellow and/or orange harnesses or harness connectors.

Precautions for Liquid Gasket

EBS00YSH

LIQUID GASKET APPLICATION PROCEDURE

1. Remove old liquid gasket adhering to the liquid gasket application surface and the mating surface, Using scraper.
 - Remove liquid gasket completely from the groove of the liquid gasket application surface, bolts, and bolt holes.
2. Thoroughly clean the mating surfaces and remove adhering moisture, grease and foreign materials.

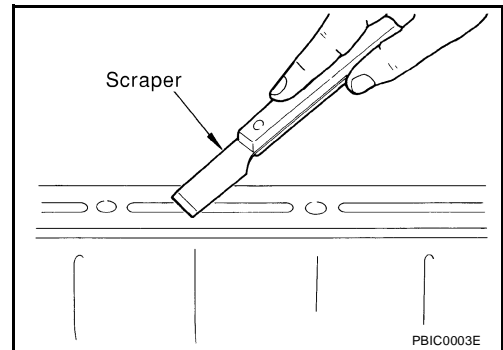

3. Attach liquid gasket tube to Tool.

Tool number : WS39930000 (—)

Use Genuine RTV Silicone Sealant or equivalent. Refer to [GI-47, "Recommended Chemical Products and Sealants"](#) .

4. Apply liquid gasket without breaks to the specified location with the specified dimensions.
 - If there is a groove for the liquid gasket application, apply liquid gasket to the groove.

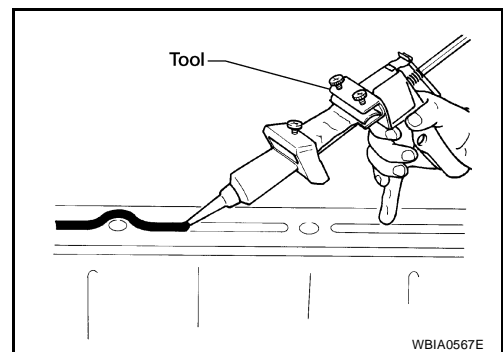

PRECAUTIONS

[VQ]

- As for the bolt holes, normally apply liquid gasket inside the holes. Occasionally, it should be applied outside the holes. Make sure to read the text of service manual.
- Within five minutes of liquid gasket application, install the mating component.
- If liquid gasket protrudes, wipe it off immediately.
- Do not retighten nuts or bolts after the installation.
- After 30 minutes or more have passed from the installation, fill engine oil and engine coolant.

CAUTION:

If there are specific instructions in this manual, observe them.

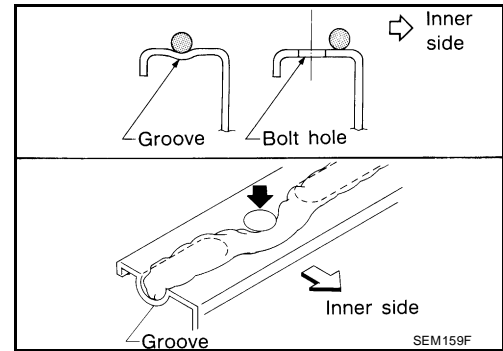

PREPARATION

[VQ]

PF0:00002

EBS00YSI

PREPARATION

Special Service Tools

The actual shapes of Kent-Moore tools may differ from those of special service tools illustrated here.

Tool number (Kent-Moore No.) Tool name	Description
ST25051001 (J-25695-1) Oil pressure gauge	Measuring oil pressure Maximum measuring range: 2,452 kPa (25 kg/cm² , 356 psi)
ST25052000 (J-25695-2) Hose	Adapting oil pressure gauge to oil pan (upper)
KV10115801 (J-38956) Oil filter wrench	Removing oil filter a: 64.3 mm (2.531 in)
WS39930000 (—) Tube presser	Pressing the tube of liquid gasket

Commercial Service Tools

EBS00YSJ

Tool name	Description
Power tool	Loosening nuts and bolts
Deep socket	Removing and installing oil pressure sensor a: 24 mm (0.94 in)

LUBRICATION SYSTEM

Lubrication Circuit

EBS00YSK

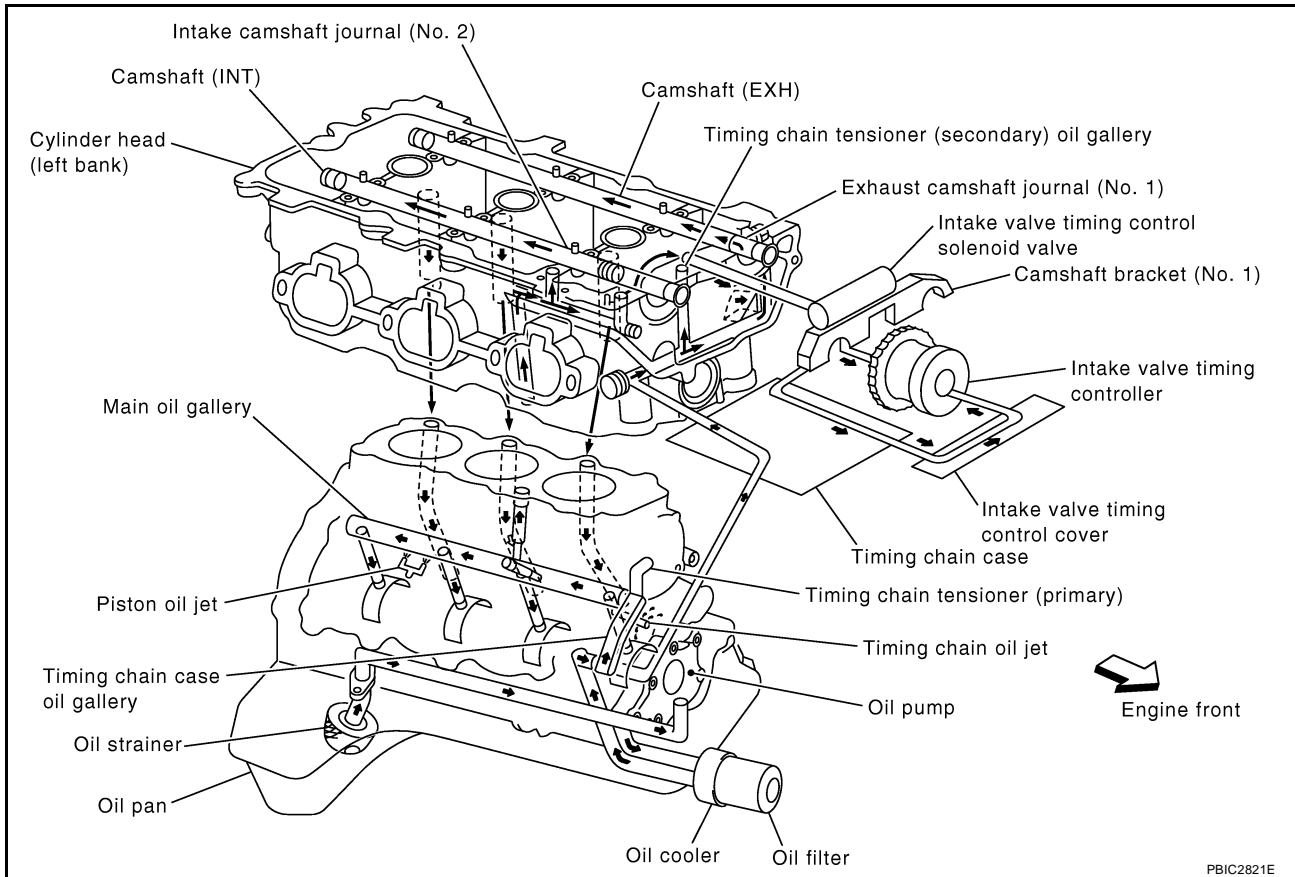

LUBRICATION SYSTEM

[VQ]

System Chart

EBS00YSL

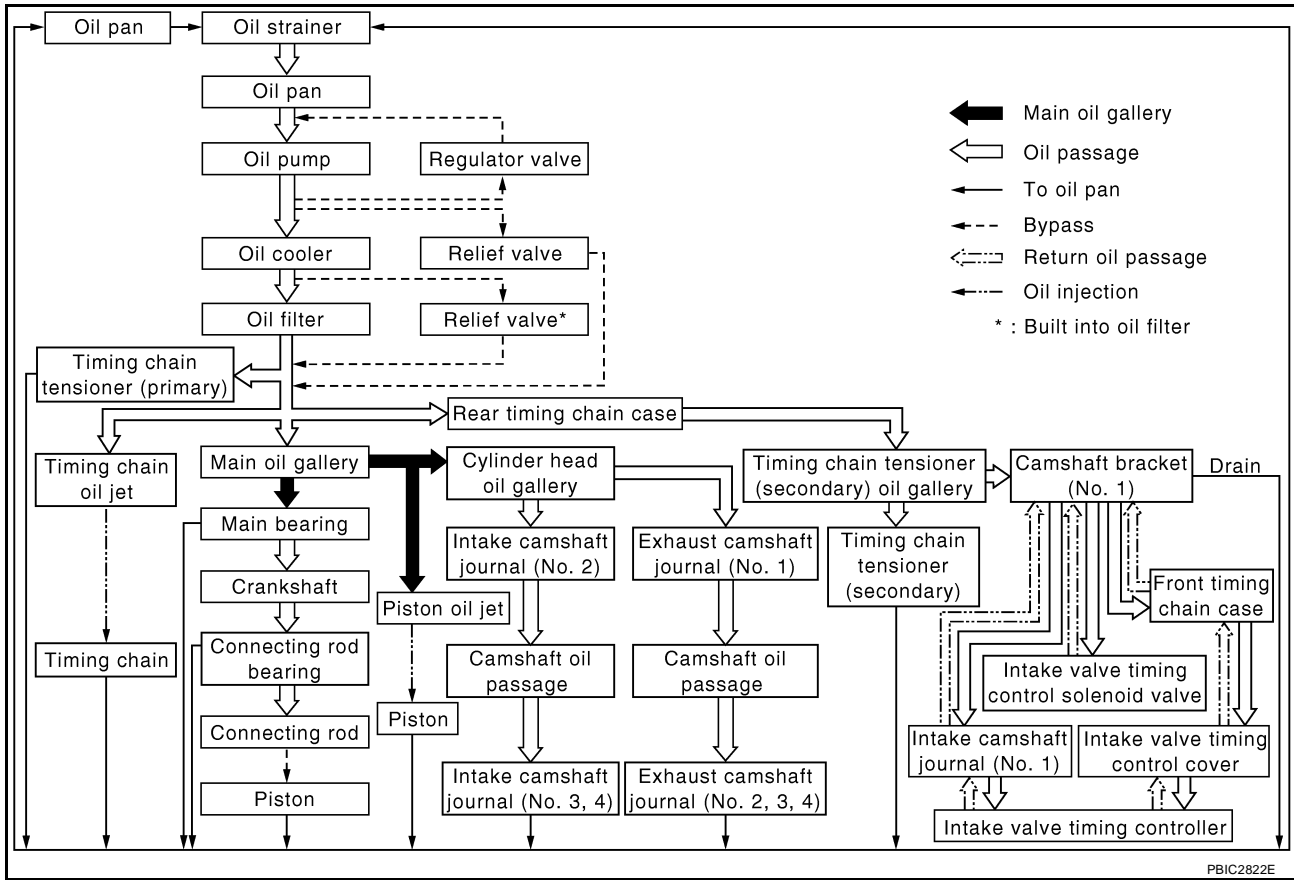

A
LU
C
D
E
F
G
H
I
J
K
L
M

ENGINE OIL

PFPP:KLA92

EBS00YSM

Inspection ENGINE OIL LEVEL

Before starting the engine make sure the vehicle is parked on a flat and level surface, then check the oil level. If the engine is already running, turn it off and allow 10 minutes before checking.

1. Pull out oil level gauge and wipe it clean.
2. Insert oil level gauge and make sure the engine oil level is within the range as indicated on gauge.
3. If the engine oil is out of range, add oil as necessary.

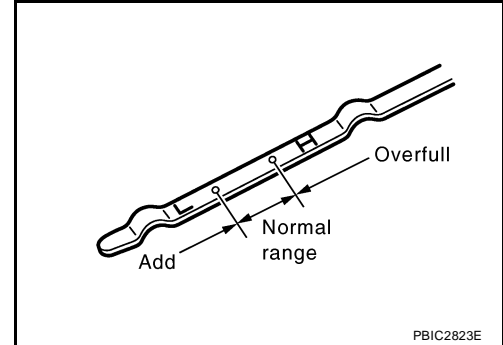

ENGINE OIL APPEARANCE

- Check engine oil for white milky or excessive contamination.
- If engine oil becomes milky, it is highly probable that it is contaminated with engine coolant. Repair or replace damaged parts.

ENGINE OIL LEAKAGE

Check for oil leakage around the following areas:

- Oil pans (lower and upper)
- Oil pan drain plug
- Oil pressure switch
- Oil filter
- Oil cooler
- Water pump cover
- Chain tensioner cover
- Intake valve timing control cover and intake valve timing control solenoid valve
- Mating surface between cylinder block and cylinder head
- Mating surface between lower cylinder block and cylinder block
- Mating surface between cylinder head and rocker cover
- Mating surface between front timing chain case and rear timing chain case
- Mating surface between rear timing chain case and cylinder head
- Mating surface between rear timing chain case and cylinder block
- Mating surface between rear timing chain case and lower cylinder block
- Mating surface between rear timing chain case and oil pan (upper)
- Crankshaft oil seals (front and rear)
- Oil level gauge guide
- Camshaft position sensor (PHASE)

OIL PRESSURE CHECK

WARNING:

- Be careful not to burn yourself, as engine oil may be hot.
- Oil pressure check should be done in "Parking position" (A/T models).

1. Check engine oil level. Refer to [LU-18, "ENGINE OIL LEVEL"](#).
2. Remove undercover with power tool.
3. Disconnect oil pressure switch harness connector.
4. Disconnect harness connector at oil pressure switch (B), and remove oil pressure switch (B).

CAUTION:

Do not drop or shock oil pressure switch.

- A: Oil pan (upper)
- ⇒: Front

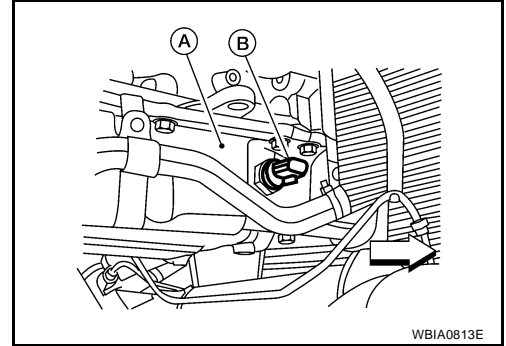

5. Install Tools.

Tool numbers : ST25051001 (J-25695-1)
 : ST25052000 (J-25695-2)

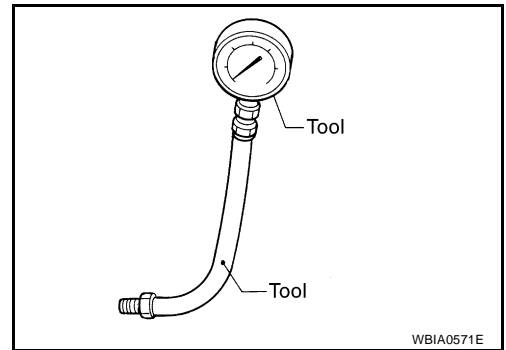

6. Start engine and warm it up to normal operating temperature.
7. Check oil pressure with engine running under no-load.

NOTE:

When engine oil temperature is low, engine oil pressure becomes high.

Engine oil pressure [Engine oil temperature at 80°C (176°F)]

Engine speed rpm	Approximate discharge pressure kPa (kg/cm ² , psi)
Idle speed	More than 98 (1.0, 14)
2,000	More than 294 (3.0, 43)

If difference is extreme, check oil passage and oil pump for oil leaks.

8. After the inspections, install oil pressure switch as follows:
 - a. Remove old liquid gasket adhering to oil presser switch and engine.
 - b. Apply liquid gasket and tighten oil pressure switch to the specification.
Use Genuine RTV Silicone Sealant or equivalent. Refer to [GI-47, "Recommended Chemical Products and Sealants"](#).

Oil pressure switch torque : 14.7 N·m (1.5 kg·m, 11 ft·lb)

- c. After warming up engine, make sure there is no leakage of engine oil with running engine.

Changing Engine Oil

WARNING:

- Be careful not to burn yourself, as engine oil may be hot.
 - Prolonged and repeated contact with used engine oil may cause skin cancer; try to avoid direct skin contact with used engine oil. If skin contact is made, wash thoroughly with soap or hand cleaner as soon as possible.
1. Warm up engine, put vehicle on flat and level surface then check for engine oil leakage from engine components. Refer to [LU-18, "ENGINE OIL LEAKAGE"](#) .
 2. Stop engine and wait for 10 minutes.
 3. Loosen oil filler cap and then remove drain plug.
 4. Drain engine oil.
 5. Install drain plug with new washer. Refer to [EM-137, "OIL PAN AND OIL STRAINER"](#) .

CAUTION:

Be sure to clean drain plug and install with new washer.

Oil pan drain plug : 34.3 N-m (3.5 kg-m, 25ft-lb)

6. Refill with new engine oil.
Engine oil specification and viscosity:
 Refer to [MA-11, "RECOMMENDED FLUIDS AND LUBRICANTS"](#) .

Engine oil capacity (Approximate):

Unit: ℓ (US qt, Imp qt)

Drain and refill	With oil filter change	5.1 (5 3/8, 4-1/2)
	Without oil filter change	4.8 (5-1/8, 4-1/4)
Dry engine (Overhaul)		6.3 (6-5/8, 5-1/2)

CAUTION:

- When filling engine oil, do not pull out oil level gauge.
 - The refill capacity depends on the engine oil temperature and drain time. Use these specifications for reference only.
 - Always use oil level gauge to determine the proper amount of engine oil in engine.
7. Warm up engine and check area around drain plug and oil filter for oil leakage.
 8. Stop engine and wait for 10 minutes.
 9. Check the engine oil level. Refer to [LU-18, "ENGINE OIL LEVEL"](#) .

OIL FILTER

Changing Oil Filter

1. Remove the undercover using power tool.
2. Remove the oil filter using Tool.

Tool number : KV10115801 (J-38956)

WARNING:

Be careful not to burn yourself, as the engine and engine oil are hot.

CAUTION:

- Oil filter is provided with relief valve. Use Genuine NISSAN Oil Filter or equivalent.
- When removing, prepare a shop cloth to absorb any engine oil leakage or spillage.
- Do not allow engine oil to adhere to drive belts.
- Completely wipe off any engine oil that adheres to engine and vehicle.

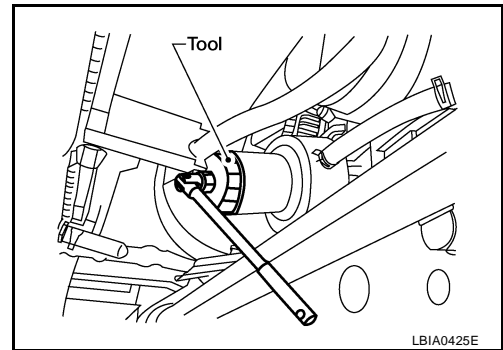

3. Remove any foreign materials adhering to the oil filter installation surface.
4. Apply new engine oil to the oil seal contact surface of new oil filter as shown.

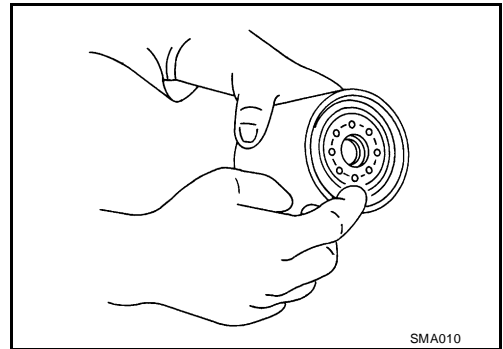

5. Screw on the oil filter manually until a slight resistance is felt, then tighten the oil filter an additional 2/3 turn as shown. Or tighten to specification.

Oil filter : 17.7 N·m (1.8 kg·m, 13 ft·lb)

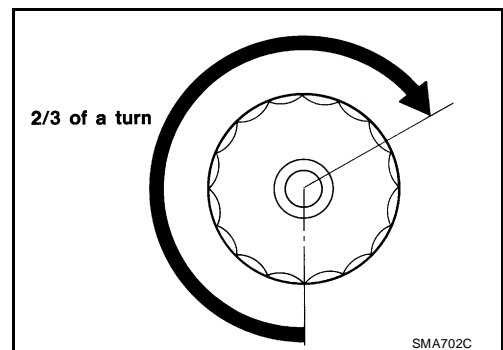

6. Install the undercover.
7. Check the engine oil level using the dipstick as shown, adjust the engine oil level as necessary.
8. Start the engine and check for engine oil leaks, correct as necessary.
9. Stop the engine and wait for 10 minutes.
10. Check the engine oil level using the dipstick and adjust the engine oil level as necessary.

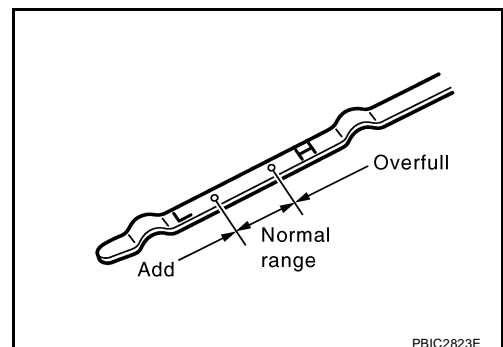

OIL COOLER

Removal and Installation

SEC. 150•211•213

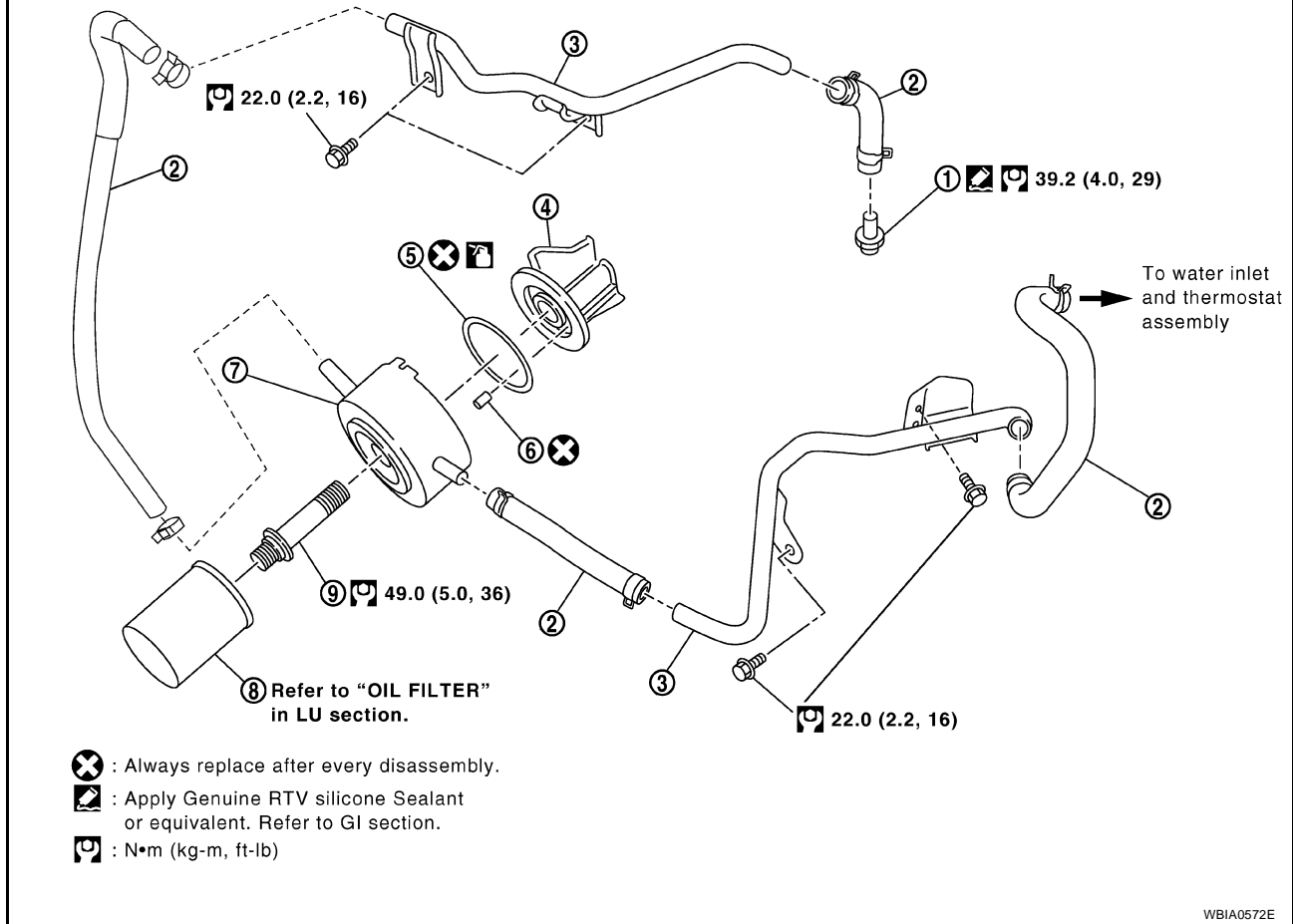

WBIA0572E

- | | | |
|-------------------------------|---------------|-------------------|
| 1. Water connector | 2. Water hose | 3. Water pipe |
| 4. Oil pan (upper) front side | 5. O-ring | 6. Relief valve |
| 7. Oil cooler | 8. Oil filter | 9. Connector bolt |

WARNING:

Be careful not to get burn yourself, as engine oil and engine coolant are hot.

REMOVAL

NOTE:

When removing oil cooler only, step 1 is unnecessary.

1. Drain engine coolant from radiator and cylinder block. Refer to [CO-37, "ENGINE COOLANT"](#) and [EM-218, "DISASSEMBLY"](#).

NOTE:

Perform this step when removing water pipes.

2. Remove oil filter. Refer to [LU-21, "Changing Oil Filter"](#).

CAUTION:

Do not spill engine oil on drive belts.

3. Disconnect water hoses from oil cooler.

- When removing oil cooler only, pinching water hoses near oil cooler to prevent engine coolant spilling.

CAUTION:

- Perform this step when engine is cold.
- Do not spill engine coolant on drive belts.

4. Remove connector bolt, and remove oil cooler.

CAUTION:

Do not spill engine oil to rubber parts such as drive belts and engine mounting insulator.

- Remove water pipes, as necessary.

INSPECTION AFTER REMOVAL**Oil Cooler**

Check oil cooler for cracks. Check oil cooler for clogging by blowing through engine coolant inlet. If necessary, replace oil cooler.

Relief Valve

Check relief valve for movement, cracks and breaks by pushing the ball. If replacement is necessary, remove relief valve by prying it out using a suitable tool. Install a new relief valve in place by tapping it in.

INSTALLATION

Installation is in the reverse order of removal, paying attention to the following.

- Make sure that no foreign objects are adhering to the installation planes of oil cooler and oil pan (upper).
- Tighten connector bolt after aligning cutout on oil cooler with protrusion on oil pan (upper) side.

Connector bolt torque : 49 N·m (5.0 kg·m, 36 ft·lb)

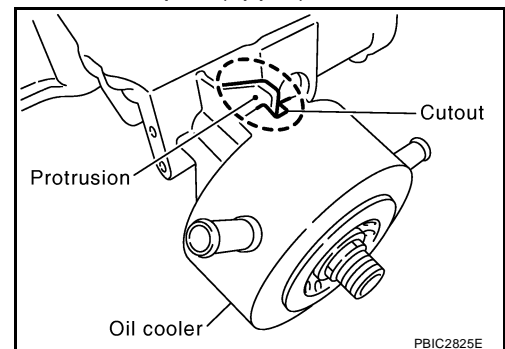
**INSPECTION AFTER INSTALLATION**

- Check the engine oil level and the engine coolant level, and add engine oil and engine coolant. Refer to [LU-18, "ENGINE OIL LEVEL"](#) and [CO-37, "ENGINE COOLANT"](#).
- Start engine, and make sure that there are no leaks of engine oil or engine coolant.
- Stop engine and wait for 10 minutes.
- Check the engine oil level and the engine coolant level again. Refer to [LU-18, "ENGINE OIL LEVEL"](#) and [CO-37, "ENGINE COOLANT"](#).

OIL PUMP

PFP:15010

Removal and Installation

EBS00YSQ

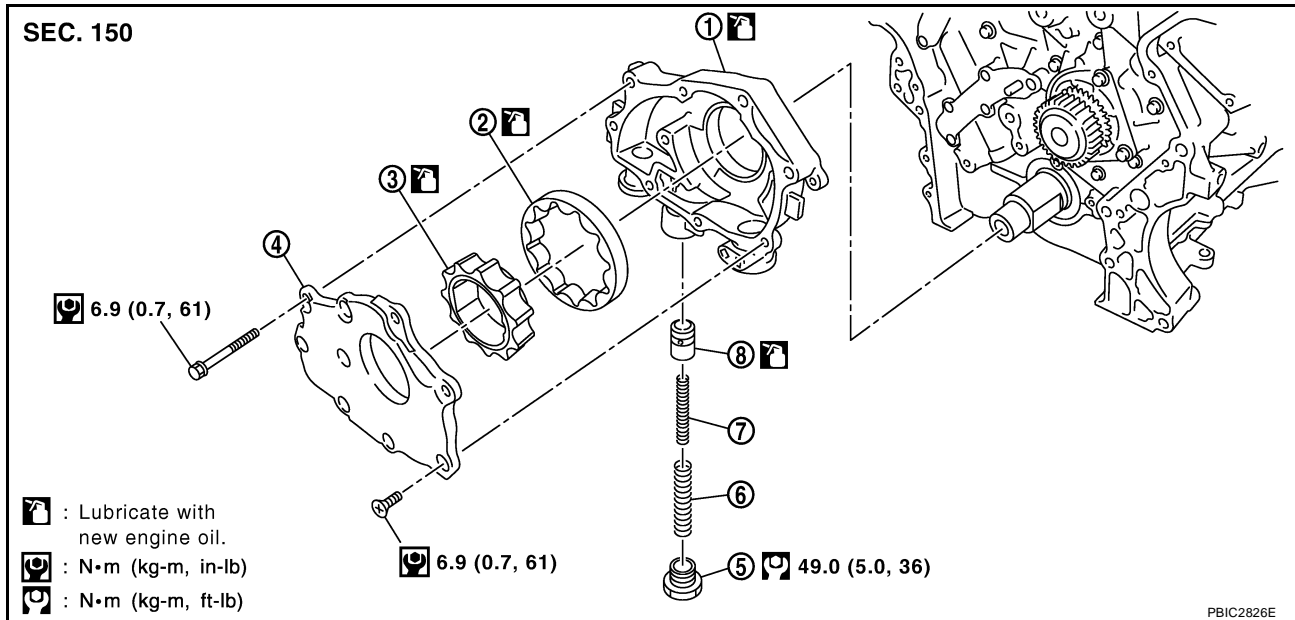

- | | | |
|---------------------------|-------------------------|---------------------------|
| 1. Oil pump body | 2. Oil pump outer rotor | 3. Oil pump inner rotor |
| 4. Oil pump cover | 5. Regulator valve plug | 6. Regulator valve spring |
| 7. Regulator valve spring | 8. Regulator valve | |

REMOVAL

1. Remove oil pans (lower and upper). Refer to [EM-137, "Removal and Installation"](#) .
2. Remove front timing chain case and timing chain (primary). Refer to [EM-165, "Removal and Installation"](#) .
3. Remove oil pump assembly.

INSTALLATION

Installation is in the reverse order of removal, paying attention to the following.

- When installing, align crankshaft flat faces with inner rotor flat faces.

INSPECTION AFTER INSTALLATION

1. Check the engine oil level. Refer to [LU-18, "ENGINE OIL LEVEL"](#) .
2. Start engine, and check there are no leaks of engine oil.
3. Stop engine and wait for 10 minutes.
4. Check the engine oil level and add engine oil. Refer to [LU-18, "ENGINE OIL LEVEL"](#) .

Disassembly and Assembly

DISASSEMBLY

1. Remove oil pump cover.
2. Remove oil pump inner rotor and oil pump outer rotor from oil pump body.
3. After removing regulator valve plug, remove regulator valve springs and regulator valve.

EBS00YSR

INSPECTION AFTER DISASSEMBLY

Oil Pump Clearance

- Measure the clearance with feeler gauge.
 - Clearance between oil pump outer rotor and oil pump body (position "1")

Standard : 0.120 - 0.195 mm (0.0047 - 0.0077 in)
 - Tip clearance between oil pump inner rotor and oil pump outer rotor (position "2")

Standard : 0.06 - 0.16 mm (0.0024 - 0.0063 in)

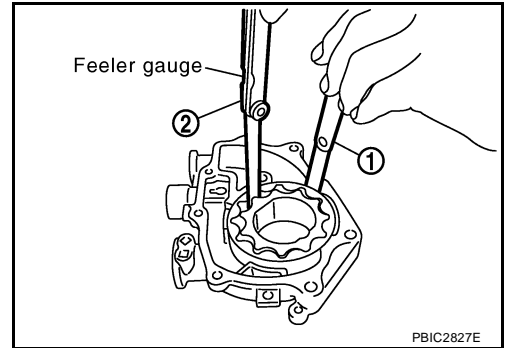

- Measure the clearance with feeler gauge and straightedge.
 - Side clearance between oil pump inner rotor and oil pump body (position "3")

Standard : 0.030 - 0.070 mm (0.0012 - 0.0028 in)
 - Side clearance between oil pump outer rotor and oil pump body (position "4")

Standard : 0.05 - 0.09 mm (0.0020 - 0.0035 in)

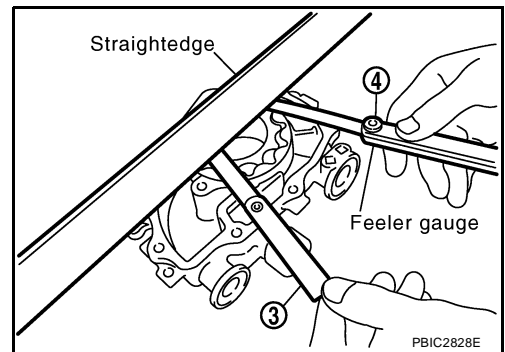

- Calculate the clearance between oil pump inner rotor and oil pump body as follows:

OIL PUMP BODY INNER DIAMETER

- Measure the inner diameter of oil pump body with inside micrometer. (position "5")

OIL PUMP INNER ROTOR OUTER DIAMETER

- Measure the outer diameter of protruded portion of oil pump inner rotor with micrometer. (position "6")

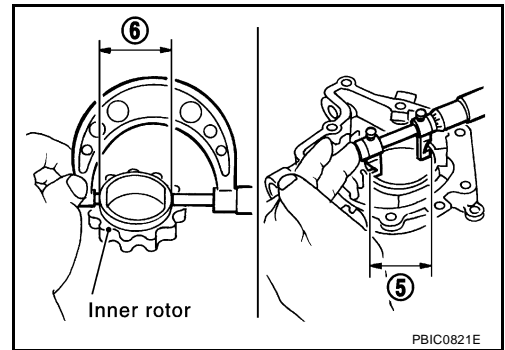

OIL PUMP INNER ROTOR TO OIL PUMP BODY CLEARANCE

- (Clearance) = (Oil pump body inner diameter) – (Oil pump inner rotor outer diameter)

Standard : 0.045 - 0.091 mm (0.0018 - 0.0036 in)

- If measured/calculated values are out of the standard, replace oil pump assembly.

Regulator Valve Clearance

(Clearance) = (Valve hole diameter) – (Regulator valve outer diameter)

Standard : 0.025 - 0.070 mm (0.0010 - 0.0028 in)

- If the calculated value is out of the standard, replace oil pump assembly.

CAUTION:

- Coat regulator valve with engine oil.
- Make sure that it falls smoothly into valve hole by its own weight.

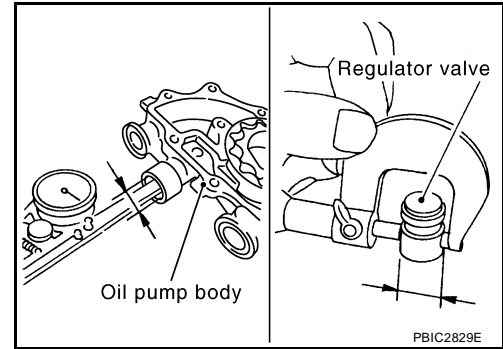

ASSEMBLY

Note the following, and assemble in the reverse order of disassembly.

- Install oil pump inner rotor with the groove faced and oil pump outer rotor with the punch mark to oil pump cover side.

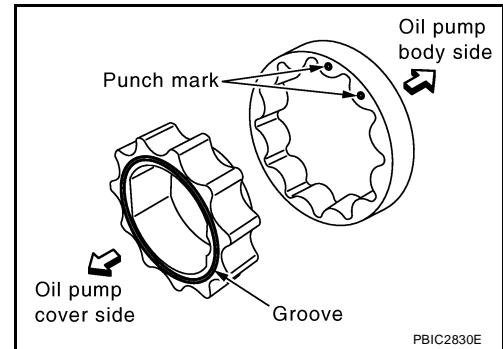

SERVICE DATA AND SPECIFICATIONS (SDS)

[VQ]

SERVICE DATA AND SPECIFICATIONS (SDS)

PFP:00030

Standard and Limit OIL PRESSURE

EBS00YSS

Engine speed rpm	Approximate discharge pressure* kPa (kg/cm ² , psi)
Idle speed	More than 98 (1.0, 14)
2,000	More than 294 (3.0, 43)

*: Engine oil temperature at 80°C (176°F)

OIL CAPACITY (APPROXIMATE)

Unit: ℓ (US qt, Imp qt)

Drain and refill	With oil filter change	5.1 (5-3/8, 4-1/2)
	Without oil filter change	4.8 (5-1/8, 4-1/4)
Dry engine (Overhaul)		6.3 (6-5/8, 5-1/2)

OIL PUMP

Unit: mm (in)

Body to outer rotor radial clearance	0.120 - 0.195 (0.0047 - 0.0077)
Inner rotor to outer rotor tip clearance	0.06 - 0.16 (0.0024 - 0.0063)
Body to inner rotor side clearance	0.030 - 0.070 (0.0012 - 0.0028)
Body to outer rotor side clearance	0.05 - 0.09 (0.0020 - 0.0035)
Inner rotor to brazed portion of housing clearance	0.045 - 0.091 (0.0018 - 0.0036)

REGULATOR VALVE

Unit: mm (in)

Regulator valve to oil pump body clearance	0.025 - 0.070 (0.0010 - 0.0028)
--	---------------------------------

