

A  
B  
AT  
D  
E  
F  
G  
H  
I  
J  
K  
L  
M

# SECTION **AT**

## AUTOMATIC TRANSMISSION

### CONTENTS

<b>INDEX FOR DTC</b> .....	<b>5</b>	A/T Electrical Parts Location .....	<b>50</b>
Alphabetical Index .....	5	Schematic .....	51
DTC No. Index .....	6	Inspections Before Trouble Diagnosis .....	52
<b>PRECAUTIONS</b> .....	<b>7</b>	Check Before Engine is Started .....	56
Precautions for Supplemental Restraint System (SRS) "AIR BAG" and "SEAT BELT PRE-TENSIONER" .....	7	Check at Idle .....	56
Precautions for On Board Diagnostic (OBD) System of A/T and Engine .....	7	Cruise Test - Part 1 .....	57
Precautions .....	8	Cruise Test - Part 2 .....	59
Service Notice or Precautions .....	9	Cruise Test - Part 3 .....	60
<b>PREPARATION</b> .....	<b>10</b>	Vehicle Speed at Which Gear Shifting Occurs .....	61
Special Service Tools .....	10	Vehicle Speed at Which Lock-up Occurs/Releases..	62
Commercial Service Tools .....	11	Symptom Chart .....	64
<b>A/T FLUID</b> .....	<b>12</b>	TCM Input/Output Signal Reference Values .....	86
Checking the A/T Fluid (ATF) .....	12	CONSULT-II Function (A/T) .....	87
Changing the A/T Fluid (ATF) .....	14	Diagnostic Procedure Without CONSULT-II .....	96
A/T Fluid Cooler Cleaning .....	15	<b>DTC U1000 CAN COMMUNICATION LINE</b> .....	<b>98</b>
<b>A/T CONTROL SYSTEM</b> .....	<b>18</b>	Description .....	98
Cross-Sectional View .....	18	On Board Diagnosis Logic .....	98
Shift Mechanism .....	20	Possible Cause .....	98
TCM Function .....	31	DTC Confirmation Procedure .....	98
CAN Communication .....	32	Wiring Diagram — AT — CAN .....	99
Input/Output Signal of TCM .....	32	Diagnostic Procedure .....	100
Line Pressure Control .....	33	<b>DTC P0615 START SIGNAL CIRCUIT</b> .....	<b>101</b>
Shift Control .....	34	Description .....	101
Lock-up Control .....	35	CONSULT-II Reference Value .....	101
Engine Brake Control .....	36	On Board Diagnosis Logic .....	101
Control Valve .....	37	Possible Cause .....	101
<b>ON BOARD DIAGNOSTIC (OBD) SYSTEM</b> .....	<b>39</b>	DTC Confirmation Procedure .....	101
Introduction .....	39	Wiring Diagram — AT — STSIG .....	102
OBD-II Function for A/T System .....	39	Diagnostic Procedure .....	103
One or Two Trip Detection Logic of OBD-II .....	39	<b>DTC P0700 TCM</b> .....	<b>105</b>
OBD-II Diagnostic Trouble Code (DTC) .....	39	Description .....	105
Malfunction Indicator Lamp (MIL) .....	42	On Board Diagnosis Logic .....	105
<b>TROUBLE DIAGNOSIS</b> .....	<b>43</b>	Possible Cause .....	105
DTC Inspection Priority Chart .....	43	DTC Confirmation Procedure .....	105
Fail-Safe .....	43	Diagnostic Procedure .....	105
How To Perform Trouble Diagnosis For Quick and Accurate Repair .....	45	<b>DTC P0705 PARK/NEUTRAL POSITION SWITCH</b> .....	<b>106</b>
		Description .....	106
		CONSULT-II Reference Value .....	106
		On Board Diagnosis Logic .....	106
		Possible Cause .....	106

DTC Confirmation Procedure .....	106	On Board Diagnosis Logic .....	128
Wiring Diagram — AT — PNP/SW .....	107	Possible Cause .....	128
Diagnostic Procedure .....	108	DTC Confirmation Procedure .....	128
<b>DTC P0717 TURBINE REVOLUTION SENSOR ... 110</b>		Wiring Diagram — AT — FTS .....	129
Description .....	110	Diagnostic Procedure .....	130
CONSULT-II Reference Value .....	110	Component Inspection .....	132
On Board Diagnosis Logic .....	110	<b>DTC P1721 VEHICLE SPEED SENSOR MTR .....133</b>	
Possible Cause .....	110	Description .....	133
DTC Confirmation Procedure .....	110	CONSULT-II Reference Value .....	133
Diagnostic Procedure .....	111	On Board Diagnosis Logic .....	133
<b>DTC P0720 VEHICLE SPEED SENSOR A/T (REV- OLUTION SENSOR) ..... 112</b>		Possible Cause .....	133
Description .....	112	DTC Confirmation Procedure .....	133
CONSULT-II Reference Value .....	112	Diagnostic Procedure .....	134
On Board Diagnosis Logic .....	112	<b>DTC P1730 A/T INTERLOCK .....135</b>	
Possible Cause .....	112	Description .....	135
DTC Confirmation Procedure .....	112	On Board Diagnosis Logic .....	135
Wiring Diagram — AT — VSSA/T .....	114	Possible Cause .....	135
Diagnostic Procedure .....	115	DTC Confirmation Procedure .....	135
<b>DTC P0725 ENGINE SPEED SIGNAL ..... 117</b>		Judgement of A/T Interlock .....	136
Description .....	117	Diagnostic Procedure .....	136
CONSULT-II Reference Value .....	117	<b>DTC P1731 A/T 1ST ENGINE BRAKING .....138</b>	
On Board Diagnosis Logic .....	117	Description .....	138
Possible Cause .....	117	CONSULT-II Reference Value .....	138
DTC Confirmation Procedure .....	117	On Board Diagnosis Logic .....	138
Diagnostic Procedure .....	118	Possible Cause .....	138
<b>DTC P0740 TORQUE CONVERTER CLUTCH SOLENOID VALVE ..... 119</b>		DTC Confirmation Procedure .....	138
Description .....	119	Diagnostic Procedure .....	139
CONSULT-II Reference Value .....	119	<b>DTC P1752 INPUT CLUTCH SOLENOID VALVE .140</b>	
On Board Diagnosis Logic .....	119	Description .....	140
Possible Cause .....	119	CONSULT-II Reference Value .....	140
DTC Confirmation Procedure .....	119	On Board Diagnosis Logic .....	140
Diagnostic Procedure .....	120	Possible Cause .....	140
<b>DTC P0744 A/T TCC S/V FUNCTION (LOCK-UP).121</b>		DTC Confirmation Procedure .....	140
Description .....	121	Diagnostic Procedure .....	141
CONSULT-II Reference Value .....	121	<b>DTC P1754 INPUT CLUTCH SOLENOID VALVE FUNCTION .....142</b>	
On Board Diagnosis Logic .....	121	Description .....	142
Possible Cause .....	121	CONSULT-II Reference Value .....	142
DTC Confirmation Procedure .....	121	On Board Diagnosis Logic .....	142
Diagnostic Procedure .....	122	Possible Cause .....	142
<b>DTC P0745 LINE PRESSURE SOLENOID VALVE 123</b>		DTC Confirmation Procedure .....	142
Description .....	123	Diagnostic Procedure .....	143
CONSULT-II Reference Value .....	123	<b>DTC P1757 FRONT BRAKE SOLENOID VALVE ..144</b>	
On Board Diagnosis Logic .....	123	Description .....	144
Possible Cause .....	123	CONSULT-II Reference Value .....	144
DTC Confirmation Procedure .....	123	On Board Diagnosis Logic .....	144
Diagnostic Procedure .....	124	Possible Cause .....	144
<b>DTC P1705 THROTTLE POSITION SENSOR .....125</b>		DTC Confirmation Procedure .....	144
Description .....	125	Diagnostic Procedure .....	145
CONSULT-II Reference Value .....	125	<b>DTC P1759 FRONT BRAKE SOLENOID VALVE FUNCTION .....146</b>	
On Board Diagnosis Logic .....	125	Description .....	146
Possible Cause .....	125	CONSULT-II Reference Value .....	146
DTC Confirmation Procedure .....	125	On Board Diagnosis Logic .....	146
Diagnostic Procedure .....	126	Possible Cause .....	146
<b>DTC P1710 A/T FLUID TEMPERATURE SENSOR CIRCUIT .....128</b>		DTC Confirmation Procedure .....	146
Description .....	128	Diagnostic Procedure .....	147
CONSULT-II Reference Value .....	128	<b>DTC P1762 DIRECT CLUTCH SOLENOID VALVE.148</b>	
		Description .....	148

CONSULT-II Reference Value .....	148	<b>DTC P1845 ATF PRESSURE SWITCH 5 .....</b>	<b>164</b>	
On Board Diagnosis Logic .....	148	Description .....	164	A
Possible Cause .....	148	CONSULT-II Reference Value .....	164	
DTC Confirmation Procedure .....	148	On Board Diagnosis Logic .....	164	
Diagnostic Procedure .....	149	Possible Cause .....	164	B
<b>DTC P1764 DIRECT CLUTCH SOLENOID VALVE</b>		DTC Confirmation Procedure .....	164	
<b>FUNCTION .....</b>	<b>150</b>	Diagnostic Procedure .....	165	
Description .....	150	<b>DTC P1846 ATF PRESSURE SWITCH 6 .....</b>	<b>166</b>	<b>AT</b>
CONSULT-II Reference Value .....	150	Description .....	166	
On Board Diagnosis Logic .....	150	CONSULT-II Reference Value .....	166	
Possible Cause .....	150	On Board Diagnosis Logic .....	166	
DTC Confirmation Procedure .....	150	Possible Cause .....	166	D
Diagnostic Procedure .....	151	DTC Confirmation Procedure .....	166	
<b>DTC P1767 HIGH AND LOW REVERSE CLUTCH</b>		Diagnostic Procedure .....	167	
<b>SOLENOID VALVE .....</b>	<b>152</b>	<b>MAIN POWER SUPPLY AND GROUND CIRCUIT. 168</b>		E
Description .....	152	Wiring Diagram — AT — MAIN .....	168	
CONSULT-II Reference Value .....	152	Diagnostic Procedure .....	169	
On Board Diagnosis Logic .....	152	<b>CLOSED THROTTLE POSITION AND WIDE OPEN</b>		F
Possible Cause .....	152	<b>THROTTLE POSITION CIRCUIT .....</b>	<b>172</b>	
DTC Confirmation Procedure .....	152	CONSULT-II Reference Value .....	172	
Diagnostic Procedure .....	153	Diagnostic Procedure .....	172	
<b>DTC P1769 HIGH AND LOW REVERSE CLUTCH</b>		<b>BRAKE SIGNAL CIRCUIT .....</b>	<b>173</b>	G
<b>SOLENOID VALVE FUNCTION .....</b>	<b>154</b>	CONSULT-II Reference Value .....	173	
Description .....	154	Diagnostic Procedure .....	173	
CONSULT-II Reference Value .....	154	<b>OVERDRIVE CONTROL SWITCH .....</b>	<b>174</b>	H
On Board Diagnosis Logic .....	154	CONSULT-II Reference Value .....	174	
Possible Cause .....	154	Diagnostic Procedure .....	174	
DTC Confirmation Procedure .....	154	<b>TROUBLE DIAGNOSIS FOR SYMPTOMS .....</b>	<b>176</b>	I
Diagnostic Procedure .....	155	Wiring Diagram — AT — NONDTC .....	176	
<b>DTC P1772 LOW COAST BRAKE SOLENOID</b>		O/D OFF Indicator Lamp Does Not Come On .....	178	
<b>VALVE .....</b>	<b>156</b>	Engine Cannot Be Started In “P” or “N” Position .....	179	J
Description .....	156	In “P” Position, Vehicle Moves When Pushed .....	180	
CONSULT-II Reference Value .....	156	In “N” Position, Vehicle Moves .....	181	
On Board Diagnosis Logic .....	156	Large Shock (“N” to “D” Position) .....	182	
Possible Cause .....	156	Vehicle Does Not Creep Backward In “R” Position .....	184	K
DTC Confirmation Procedure .....	156	Vehicle Does Not Creep Forward In “D” Position .....	187	
Diagnostic Procedure .....	157	Vehicle Cannot Be Started From D1 .....	189	
<b>DTC P1774 LOW COAST BRAKE SOLENOID</b>		A/T Does Not Shift: D1 → D2 .....	191	L
<b>VALVE FUNCTION .....</b>	<b>158</b>	A/T Does Not Shift: D2 → D3 .....	193	
Description .....	158	A/T Does Not Shift: D3 → D4 .....	195	
CONSULT-II Reference Value .....	158	A/T Does Not Shift: D4 → D5 .....	197	
On Board Diagnosis Logic .....	158	A/T Does Not Perform Lock-up .....	199	M
Possible Cause .....	158	A/T Does Not Hold Lock-up Condition .....	201	
DTC Confirmation Procedure .....	158	Lock-up Is Not Released .....	203	
Diagnostic Procedure .....	159	Engine Speed Does Not Return to Idle .....	204	
<b>DTC P1841 ATF PRESSURE SWITCH 1 .....</b>	<b>160</b>	A/T Does Not Shift: 5th gear → 4th gear .....	206	
Description .....	160	A/T Does Not Shift: 4th gear → 3rd gear .....	208	
CONSULT-II Reference Value .....	160	A/T Does Not Shift: 3rd gear → 2nd gear .....	210	
On Board Diagnosis Logic .....	160	A/T Does Not Shift: 2nd gear → 1st gear .....	212	
Possible Cause .....	160	Vehicle Does Not Decelerate By Engine Brake ...	214	
DTC Confirmation Procedure .....	160	<b>SHIFT CONTROL SYSTEM .....</b>	<b>216</b>	
Diagnostic Procedure .....	161	Control Device Removal and Installation .....	216	
<b>DTC P1843 ATF PRESSURE SWITCH 3 .....</b>	<b>162</b>	Adjustment of A/T Position .....	217	
Description .....	162	Checking of A/T Position .....	217	
CONSULT-II Reference Value .....	162	<b>A/T SHIFT LOCK SYSTEM .....</b>	<b>218</b>	
On Board Diagnosis Logic .....	162	Description .....	218	
Possible Cause .....	162	Shift Lock System Electrical Parts Location .....	218	
DTC Confirmation Procedure .....	162	Wiring Diagram — A/T — SHIFT .....	219	
Diagnostic Procedure .....	163	Diagnostic Procedure .....	220	

<b>KEY INTERLOCK CABLE</b> .....	<b>223</b>	<b>REPAIR FOR COMPONENT PARTS</b> .....	<b>285</b>
Components .....	223	Oil Pump .....	285
Removal and Installation .....	224	Front Sun Gear, 3rd One-Way Clutch .....	288
<b>ON-VEHICLE SERVICE</b> .....	<b>226</b>	Front Carrier, Input Clutch, Rear Internal Gear .....	290
Oil Pan .....	226	Mid Sun Gear, Rear Sun Gear, High and Low	
Control Valve With TCM and A/T Fluid Temperature		Reverse Clutch Hub .....	296
Sensor 2 .....	228	High and Low Reverse Clutch .....	301
Rear Oil Seal .....	237	Direct Clutch .....	304
<b>AIR BREATHER HOSE</b> .....	<b>238</b>	<b>ASSEMBLY</b> .....	<b>307</b>
Removal and Installation for QR25DE Engine .....	238	Assembly (1) .....	307
Removal and Installation for VQ40DE Engine .....	239	Adjustment .....	321
<b>A/T FLUID COOLER</b> .....	<b>241</b>	Assembly (2) .....	323
Removal and Installation .....	241	<b>SERVICE DATA AND SPECIFICATIONS (SDS)</b> ...	<b>330</b>
<b>TRANSMISSION ASSEMBLY</b> .....	<b>242</b>	General Specifications .....	330
Components .....	242	Vehicle Speed at Which Gear Shifting Occurs .....	330
Removal and Installation for QR25DE .....	245	Vehicle Speed at Which Lock-up Occurs/Releases .....	331
Removal and Installation for VQ40DE 2WD Models .....	248	Stall Speed .....	332
Removal and Installation for VQ40DE 4WD Models .....	251	Line Pressure .....	332
<b>OVERHAUL</b> .....	<b>254</b>	A/T Fluid Temperature Sensor .....	332
Components .....	254	Turbine Revolution Sensor .....	332
Oil Channel .....	264	Vehicle Speed Sensor A/T (Revolution Sensor) .....	332
Locations of Adjusting Shims, Needle Bearings,		Reverse brake .....	333
Thrust Washers and Snap Rings .....	266	Total End Play .....	333
<b>DISASSEMBLY</b> .....	<b>268</b>		
Disassembly .....	268		

# INDEX FOR DTC

## INDEX FOR DTC

PFP:00024

### Alphabetical Index

UCS0041A

#### NOTE:

If DTC U1000 is displayed with other DTC, first perform the trouble diagnosis for DTC U1000. Refer to [AT-98, "DTC U1000 CAN COMMUNICATION LINE"](#).

Items (CONSULT- II screen terms)	DTC		Reference page
	OBD- II	Except OBD- II	
	CONSULT- II GST (*1)	CONSULT- II only "A/T"	
A/T 1ST E/BRAKING	—	P1731	<a href="#">AT-138</a>
ATF PRES SW 1/CIRC	—	P1841	<a href="#">AT-160</a>
ATF PRES SW 3/CIRC	—	P1843	<a href="#">AT-162</a>
ATF PRES SW 5/CIRC	—	P1845	<a href="#">AT-164</a>
ATF PRES SW 6/CIRC	—	P1846	<a href="#">AT-166</a>
A/T INTERLOCK	P1730	P1730	<a href="#">AT-135</a>
A/T TCC S/V FNCTN	P0744 (*2)	P0744	<a href="#">AT-121</a>
ATF TEMP SEN/CIRC	P0710	P1710	<a href="#">AT-128</a>
CAN COMM CIRCUIT	U1000	U1000	<a href="#">AT-98</a>
D/C SOLENOID/CIRC	P1762	P1762	<a href="#">AT-148</a>
D/C SOLENOID FNCTN	P1764 (*2)	P1764	<a href="#">AT-150</a>
ENGINE SPEED SIG	—	P0725	<a href="#">AT-117</a>
FR/B SOLENOID/CIRC	P1757	P1757	<a href="#">AT-144</a>
FR/B SOLENOID FNCT	P1759 (*2)	P1759	<a href="#">AT-146</a>
HLR/C SOL/CIRC	P1767	P1767	<a href="#">AT-152</a>
HLR/C SOL FNCTN	P1769 (*2)	P1769	<a href="#">AT-154</a>
I/C SOLENOID/CIRC	P1752	P1752	<a href="#">AT-140</a>
I/C SOLENOID FNCTN	P1754 (*2)	P1754	<a href="#">AT-142</a>
L/PRESS SOL/CIRC	P0745	P0745	<a href="#">AT-123</a>
LC/B SOLENOID/CIRC	P1772	P1772	<a href="#">AT-156</a>
LC/B SOLENOID FNCT	P1774 (*2)	P1774	<a href="#">AT-158</a>
PNP SW/CIRC	P0705	P0705	<a href="#">AT-106</a>
STARTER RELAY/CIRC	—	P0615	<a href="#">AT-101</a>
TCC SOLENOID/CIRC	P0740	P0740	<a href="#">AT-119</a>
TCM	P0700	P0700	<a href="#">AT-105</a>
TP SEN/CIRC A/T	—	P1705	<a href="#">AT-125</a>
TURBINE REV S/CIRC	P0717	P0717	<a href="#">AT-110</a>
VEH SPD SE/CIR-MTR	—	P1721	<a href="#">AT-133</a>
VEH SPD SEN/CIR AT	P0720	P0720	<a href="#">AT-112</a>

\*1: These numbers are prescribed by SAE J2012.

\*2: These malfunctions cannot be displayed MIL if another malfunction is assigned to MIL.

# INDEX FOR DTC

UCS0041B

## DTC No. Index

**NOTE:**

If DTC U1000 is displayed with other DTC, first perform the trouble diagnosis for DTC U1000. Refer to [AT-98, "DTC U1000 CAN COMMUNICATION LINE"](#) .

DTC		Items (CONSULT- II screen terms)	Reference page
OBD- II CONSULT- II GST (*1)	Except OBD- II CONSULT- II only "A/T"		
—	P0615	STARTER RELAY/CIRC	<a href="#">AT-101</a>
P0700	P0700	TCM	<a href="#">AT-105</a>
P0705	P0705	PNP SW/CIRC	<a href="#">AT-106</a>
P0710	P1710	ATF TEMP SEN/CIRC	<a href="#">AT-128</a>
P0717	P0717	TURBINE REV S/CIRC	<a href="#">AT-110</a>
P0720	P0720	VEH SPD SEN/CIR AT	<a href="#">AT-112</a>
—	P0725	ENGINE SPEED SIG	<a href="#">AT-117</a>
P0740	P0740	TCC SOLENOID/CIRC	<a href="#">AT-119</a>
P0744 (*2)	P0744	A/T TCC S/V FNCTN	<a href="#">AT-121</a>
P0745	P0745	L/PRESS SOL/CIRC	<a href="#">AT-123</a>
—	P1705	TP SEN/CIRC A/T	<a href="#">AT-125</a>
—	P1721	VEH SPD SE/CIR-MTR	<a href="#">AT-133</a>
P1730	P1730	A/T INTERLOCK	<a href="#">AT-135</a>
—	P1731	A/T 1ST E/BRAKING	<a href="#">AT-138</a>
P1752	P1752	I/C SOLENOID/CIRC	<a href="#">AT-140</a>
P1754 (*2)	P1754	I/C SOLENOID FNCTN	<a href="#">AT-142</a>
P1757	P1757	FR/B SOLENOID/CIRC	<a href="#">AT-144</a>
P1759 (*2)	P1759	FR/B SOLENOID FNCT	<a href="#">AT-146</a>
P1762	P1762	D/C SOLENOID/CIRC	<a href="#">AT-148</a>
P1764 (*2)	P1764	D/C SOLENOID FNCTN	<a href="#">AT-150</a>
P1767	P1767	HLR/C SOL/CIRC	<a href="#">AT-152</a>
P1769 (*2)	P1769	HLR/C SOL FNCTN	<a href="#">AT-154</a>
P1772	P1772	LC/B SOLENOID/CIRC	<a href="#">AT-156</a>
P1774 (*2)	P1774	LC/B SOLENOID FNCT	<a href="#">AT-158</a>
—	P1841	ATF PRES SW 1/CIRC	<a href="#">AT-160</a>
—	P1843	ATF PRES SW 3/CIRC	<a href="#">AT-162</a>
—	P1845	ATF PRES SW 5/CIRC	<a href="#">AT-164</a>
—	P1846	ATF PRES SW 6/CIRC	<a href="#">AT-166</a>
U1000	U1000	CAN COMM CIRCUIT	<a href="#">AT-98</a>

\*1: These numbers are prescribed by SAE J2012.

\*2: These malfunctions cannot be displayed MIL if another malfunction is assigned to MIL.

# PRECAUTIONS

## PRECAUTIONS

PF0:00001

### Precautions for Supplemental Restraint System (SRS) “AIR BAG” and “SEAT BELT PRE-TENSIONER”

UCS0041C

The Supplemental Restraint System such as “AIR BAG” and “SEAT BELT PRE-TENSIONER”, used along with a front seat belt, helps to reduce the risk or severity of injury to the driver and front passenger for certain types of collision. This system includes seat belt switch inputs and dual stage front air bag modules. The SRS system uses the seat belt switches to determine the front air bag deployment, and may only deploy one front air bag, depending on the severity of a collision and whether the front occupants are belted or unbelted. Information necessary to service the system safely is included in the SRS and SB section of this Service Manual.

#### **WARNING:**

- To avoid rendering the SRS inoperative, which could increase the risk of personal injury or death in the event of a collision which would result in air bag inflation, all maintenance must be performed by an authorized NISSAN/INFINITI dealer.
- Improper maintenance, including incorrect removal and installation of the SRS, can lead to personal injury caused by unintentional activation of the system. For removal of Spiral Cable and Air Bag Module, see the SRS section.
- Do not use electrical test equipment on any circuit related to the SRS unless instructed to in this Service Manual. SRS wiring harnesses can be identified by yellow and/or orange harnesses or harness connectors.

### Precautions for On Board Diagnostic (OBD) System of A/T and Engine

UCS0041D

The ECM has an on board diagnostic system. It will light up the malfunction indicator lamp (MIL) to warn the driver of a malfunction causing emission deterioration.

#### **CAUTION:**

- Be sure to turn the ignition switch “OFF” and disconnect the negative battery cable before any repair or inspection work. The open/short circuit of related switches, sensors, solenoid valves, etc. Will cause the MIL to light up.
- Be sure to connect and lock the connectors securely after work. A loose (unlocked) connector will cause the MIL to light up due to an open circuit. (Be sure the connector is free from water, grease, dirt, bent terminals, etc.)
- Be sure to route and secure the harnesses properly after work. Interference of the harness with a bracket, etc. May cause the MIL to light up due to a short circuit.
- Be sure to connect rubber tubes properly after work. A mis-connected or disconnected rubber tube may cause the MIL to light up due to a malfunction of the EGR system or fuel injection system, etc.
- Be sure to erase the unnecessary malfunction information (repairs completed) from the TCM and ECM before returning the vehicle to the customer.

# PRECAUTIONS

UCS0041E

## Precautions

- Before connecting or disconnecting the A/T assembly harness connector, turn ignition switch "OFF" and disconnect negative battery cable. Because battery voltage is applied to TCM even if ignition switch is turned "OFF".

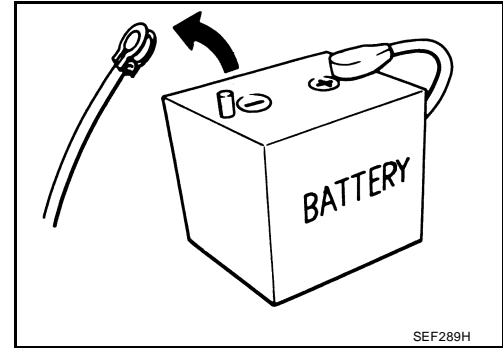

SEF289H

- After performing each TROUBLE DIAGNOSIS, perform "DTC (Diagnostic Trouble Code) CONFIRMATION PROCEDURE".  
If the repair is completed the DTC should not be displayed in the "DTC CONFIRMATION PROCEDURE".

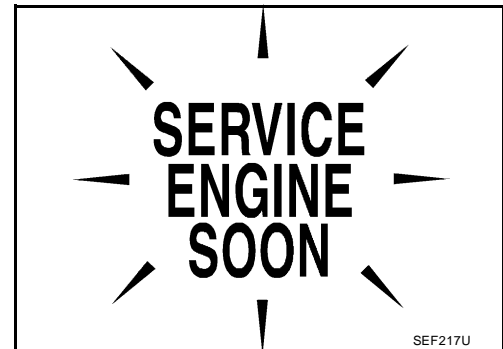

SEF217U

- Always use the specified brand of ATF. Refer to [MA-11, "RECOMMENDED FLUIDS AND LUBRICANTS"](#) .
- Use lint-free paper not cloth rags during work.
- After replacing the ATF, dispose of the waste oil using the methods prescribed by law, ordinance, etc.
- Before proceeding with disassembly, thoroughly clean the outside of the transmission. It is important to prevent the internal parts from becoming contaminated by dirt or other foreign matter.
- Disassembly should be done in a clean work area.
- Use lint-free paper or towels for wiping parts clean. Common shop rags can leave fibers that could interfere with the operation of the transmission.
- Place disassembled parts in order for easier and proper assembly.
- All parts should be carefully cleaned with a general purpose, non-flammable solvent before inspection or reassembly.
- Gaskets, seals and O-rings should be replaced any time the transmission is disassembled.
- It is very important to perform functional tests whenever they are indicated.
- The valve body contains precision parts and requires extreme care when parts are removed and serviced. Place disassembled valve body parts in order for easier and proper assembly. Care will also prevent springs and small parts from becoming scattered or lost.
- Properly installed valves, sleeves, plugs, etc. will slide along bores in valve body under their own weight.
- Before assembly, apply a coat of recommended ATF to all parts. Apply petroleum jelly to protect O-rings and seals, or hold bearings and washers in place during assembly. Do not use grease.
- Extreme care should be taken to avoid damage to O-rings, seals and gaskets when assembling.
- Clean or replace ATF cooler if excessive foreign material is found in oil pan or clogging strainer. Refer to [AT-9, "ATF COOLER SERVICE"](#) .
- After overhaul, refill the transmission with new ATF.
- When the A/T drain plug is removed, only some of the fluid is drained. Old A/T fluid will remain in torque converter and ATF cooling system.  
Always follow the procedures under "Changing A/T Fluid" in the AT section when changing A/T fluid. Refer to [AT-12, "A/T FLUID"](#) .



# PRECAUTIONS

UCS0041F

## Service Notice or Precautions

### ATF COOLER SERVICE

If A/T fluid contains frictional material (clutches, bands, etc.), or if an A/T is repaired, overhauled, or replaced, inspect and clean the A/T fluid cooler mounted in the radiator or replace the radiator. Flush cooler lines using cleaning solvent and compressed air after repair. For A/T fluid cooler cleaning procedure, refer to [AT-15, "A/T Fluid Cooler Cleaning"](#) . For radiator replacement, refer to [CO-15, "Removal and Installation"](#) for QR25DE or [CO-42, "Removal and Installation"](#) for VQ40DE.

### CHECKING AND CHANGING A/T FLUID SERVICE

Increase ATF temperature by 80°C (176°F) once, and then check ATF level in 65°C (149°F) when adjusting ATF level.

#### NOTE:

D40 uses both systems of a water-cooling and of an air-cooling. Air-cooling system has a by-pass valve. When ATF temperature is not over 50°C (122°F) with water-cooling system OFF, it does not flow to air-cooling system. If ATF level is set without the flow of ATF, the level will be 10mm lower than the standard. Therefore, piping should be filled with ATF when adjusting level.

### OBD-II SELF-DIAGNOSIS

- A/T self-diagnosis is performed by the TCM in combination with the ECM. Refer to the table on [AT-89, "SELF-DIAGNOSTIC RESULT MODE"](#) for the indicator used to display each self-diagnostic result.
- The self-diagnostic results indicated by the MIL are automatically stored in both the ECM and TCM memories.  
**Always perform the procedure on [AT-40, "HOW TO ERASE DTC"](#) to complete the repair and avoid unnecessary blinking of the MIL.**

For details of OBD-II, refer to [EC-53, "ON BOARD DIAGNOSTIC \(OBD\) SYSTEM"](#) for QR engine models or [EC-657, "ON BOARD DIAGNOSTIC \(OBD\) SYSTEM"](#) for VQ engine models.

- **Certain systems and components, especially those related to OBD, may use the new style slide-locking type harness connector. For description and how to disconnect, refer to [PG-83, "HARNESS CONNECTOR"](#) .**

# PREPARATION

## PREPARATION

PF0:00002

### Special Service Tools

UCS0041H

The actual shapes of Kent-Moore tools may differ from those of special service tools illustrated here.

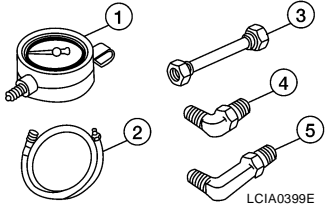
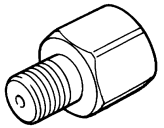
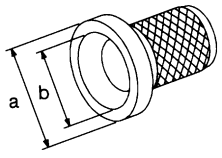
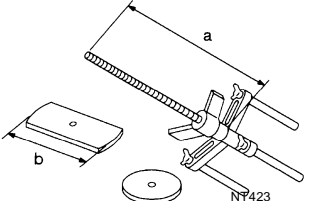
Tool number (Kent-Moore No.) Tool name	Description
<p>ST2505S001 (J-34301-C) Oil pressure gauge set 1 ST25051001 ( — ) Oil pressure gauge 2 ST25052000 ( — ) Hose 3 ST25053000 ( — ) Joint pipe 4 ST25054000 ( — ) Adapter 5 ST25055000 ( — ) Adapter</p> 	<p>Measuring line pressure</p>
<p>KV31103600 (J-45674) Joint pipe adapter (With ST25054000)</p> 	<p>Measuring line pressure</p>
<p>ST33400001 (J-26082) Drift</p> 	<ul style="list-style-type: none"> <li>● Installing rear oil seal (2WD models)</li> <li>● Installing oil pump housing oil seal</li> </ul> <p><b>a: 60 mm (2.36 in) dia.</b> <b>b: 47 mm (1.85 in) dia.</b></p>
<p>KV31102400 (J-34285 and J-34285-87) Clutch spring compressor</p> 	<p>Installing reverse brake return spring retainer</p> <p><b>a: 320 mm (12.60 in)</b> <b>b: 174 mm (6.85 in)</b></p>

# PREPARATION

Tool number (Kent-Moore No.) Tool name	Description
ST25850000 (J-25721-A) Sliding hammer <div data-bbox="609 277 938 472" style="text-align: center;"> <p>NT422</p> </div>	Remove oil pump assembly <b>a: 179 mm (7.05 in)</b> <b>b: 70 mm (2.76 in)</b> <b>c: 40 mm (1.57 in)</b> <b>d: M12X1.75P</b>
— (J-47002) Transmission jack adapter kit 1. — (J-47002-1) Center bracket 2. — (J-47002-3) Adapter plate 3. — (J-47002-4) Adapter block <div data-bbox="609 556 941 766" style="text-align: center;"> <p>WCIA0499E</p> </div>	Assist in removal of transmission and transfer case as one assembly using only one transmission jack.
<h2>Commercial Service Tools</h2> <div style="text-align: right; font-size: small;">UCS00411</div>	
Tool name	Description
Power tool <div data-bbox="625 966 922 1155" style="text-align: center;"> <p>PBIC0190E</p> </div>	Loosening bolts and nuts
Drift <div data-bbox="657 1228 893 1386" style="text-align: center;"> <p>NT083</p> </div>	Installing manual shaft seals <b>a: 22 mm (0.87 in) dia.</b>
Drift <div data-bbox="649 1449 901 1617" style="text-align: center;"> <p>SCIA5338E</p> </div>	Installing rear oil seal (4WD models) <b>a: 64 mm (2.52 in) dia.</b>
Pin punch <div data-bbox="690 1711 852 1848" style="text-align: center;"> <p>NT410</p> </div>	<ul style="list-style-type: none"> <li>● Removing retaining pin</li> <li>● Installing retaining pin</li> </ul> <b>a: 4 mm (0.16 in) dia.</b>

A  
B  
AT  
D  
E  
F  
G  
H  
I  
J  
K  
L  
M

## A/T FLUID

### Checking the A/T Fluid (ATF)

ECS001YB

**CAUTION:**

If using the vehicle for towing, the A/T fluid must be replaced as specified. Refer to [MA-7, "PERIODIC MAINTENANCE"](#) .

1. Before driving, the A/T fluid level can be checked at A/T fluid temperatures of 30° to 50° C (86° to 122° F) using the "COLD" range on the A/T fluid level gauge as follows:

- a. Park the vehicle on a level surface and set the parking brake.
- b. Start the engine and move the selector lever through each gear position. Shift the selector lever into the "P" position.
- c. Check the A/T fluid level with the engine idling.
- d. Remove the A/T fluid level gauge and wipe it clean with a lint-free paper.

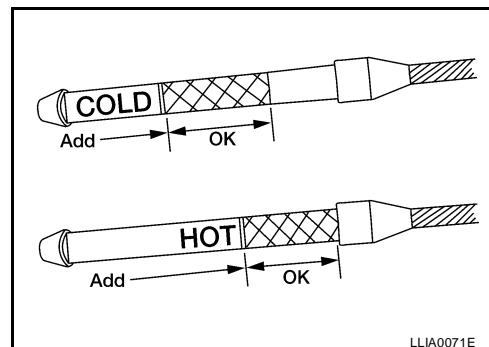

**CAUTION:**

When wiping the A/T fluid from the A/T fluid level gauge, always use a lint-free paper, not a cloth.

e. Re-insert the A/T fluid level gauge into the A/T fluid charging pipe until the cap contacts the top of the A/T fluid charging pipe as shown.

**CAUTION:**

To check A/T fluid level, insert the A/T fluid level gauge until the cap contacts the top of the A/T fluid charging pipe, with the gauge reversed from the normal inserted position.

f. Remove the A/T fluid level gauge and note the A/T fluid level. If the A/T fluid level is at low side of range, add A/T fluid to the transmission through the A/T fluid charging pipe.

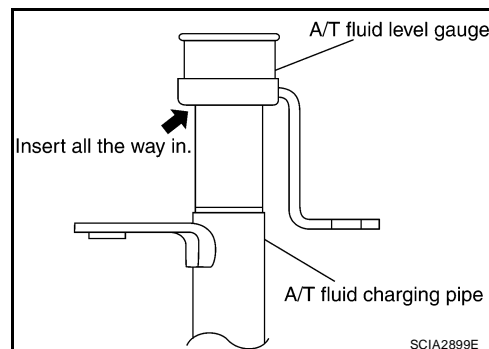

**CAUTION:**

Do not overfill the transmission with A/T fluid.

g. Install the A/T fluid level gauge and the A/T fluid level gauge bolt.

**A/T fluid level gauge bolt** : Refer to [AT-242, "Components"](#) .

2. Warm up the engine and transmission.
3. Check for any A/T fluid leaks.
4. Drive the vehicle to increase the A/T fluid temperature to 80° C (176° F).

# A/T FLUID

- Allow the A/T fluid temperature to fall to approximately 65°C (149°F). Use the CONSULT-II to monitor the A/T fluid temperature as follows:

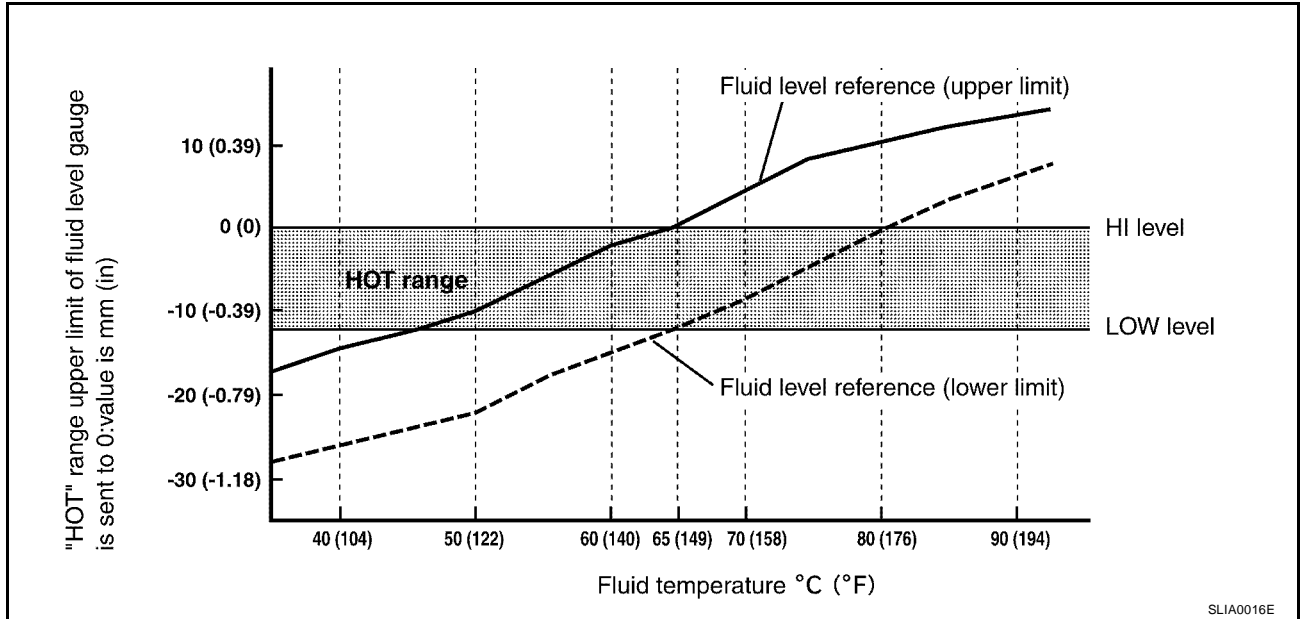

**NOTE:**

The A/T fluid level will be significantly affected by the A/T fluid temperature as shown. Therefore monitor the A/T fluid temperature data using the CONSULT-II.

- Connect CONSULT-II to data link connector.
  - Select "MAIN SIGNALS" in "DATA MONITOR" mode for "A/T" with CONSULT-II.
  - Read out the value of "ATF TEMP 1".
- Re-check the A/T fluid level at A/T fluid temperatures of approximately 65°C (149°F) using the "HOT" range on the A/T fluid level gauge as shown. The HOT range is between 50° - 80° C (122° - 176° F).

**CAUTION:**

- When wiping the A/T fluid from the A/T fluid level gauge, always use lint-free paper, not a cloth.

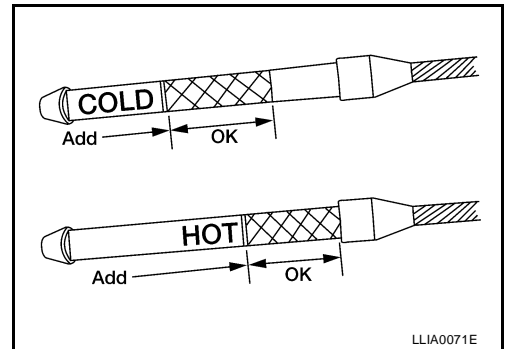

- To check the A/T fluid level, insert the A/T fluid level gauge until the cap contacts the top of the A/T fluid charging pipe, with the gauge reversed from the normal inserted position as shown.

- Check the A/T fluid condition.

- If the A/T fluid is very dark or has some burned smell, there may be an internal problem with the transmission. Refer to [AT-176, "TROUBLE DIAGNOSIS FOR SYMPTOMS"](#). Flush the transmission cooling system after repairing the transmission.
- If the A/T fluid contains frictional material (clutches, bands, etc.), replace the radiator and flush the transmission cooler lines using cleaning solvent and compressed air after repairing the transmission.

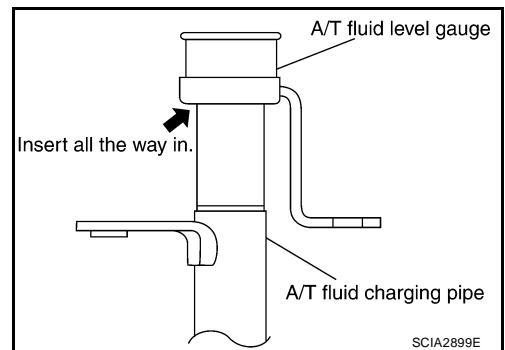

- Install the A/T fluid level gauge in the A/T fluid charging pipe.
- Tighten the A/T fluid level gauge bolt to specification.

**A/T fluid level gauge bolt** : Refer to [AT-242, "Components"](#) .

# A/T FLUID

ECS00IYC

## Changing the A/T Fluid (ATF)

### CAUTION:

If using the vehicle for towing, the A/T fluid must be replaced as specified. Refer to [MA-7, "PERIODIC MAINTENANCE"](#).

1. Drive the vehicle to warm up the A/T fluid to approximately 80° C (176° F).
2. Stop the engine.
3. Remove the A/T fluid level gauge.
4. Drain the A/T fluid from the drain plug hole, then install the drain plug with a new gasket. Refill the transmission with new A/T fluid. Always refill with the same volume as the drained A/T fluid. Use the A/T fluid level gauge to check the A/T fluid level as shown. Add A/T fluid as necessary.

**Drain plug** : Refer to [AT-242, "Components"](#).

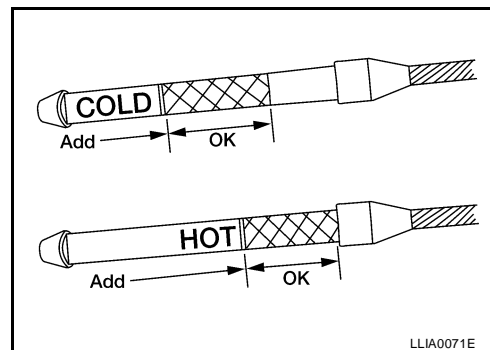

- To flush out the old A/T fluid from the transmission oil coolers, pour new A/T fluid into the A/T fluid charging pipe with the engine idling and at the same time drain the old A/T fluid from the auxiliary transmission oil cooler hose return line.
- When the color of the A/T fluid coming out of the auxiliary transmission oil cooler hose return line is about the same as the color of the new A/T fluid, flushing out the old A/T fluid is complete. The amount of new A/T fluid used for flushing should be 30% to 50% of the specified capacity.

**A/T fluid grade and capacity** : Refer to [MA-11, "Fluids and Lubricants"](#).

### CAUTION:

- Use only Genuine NISSAN Matic J ATF and do not mix with other fluids.
  - Using A/T fluid other than Genuine NISSAN Matic J ATF will cause deterioration in driveability and automatic transmission durability, and may damage the automatic transmission, which is not covered by the warranty.
  - When filling the transmission with A/T fluid, do not spill the A/T fluid on any heat generating parts such as the exhaust manifold.
  - Do not reuse the drain plug gasket.
5. Install the A/T fluid level gauge and tighten the A/T fluid level gauge bolt to specification.

**A/T fluid level gauge bolt** : Refer to [AT-242, "Components"](#).

6. Drive the vehicle to warm up the A/T fluid to approximately 80° C (176° F).
7. Check the fluid level and condition. If the A/T fluid is still dirty, repeat steps 2 through 6.

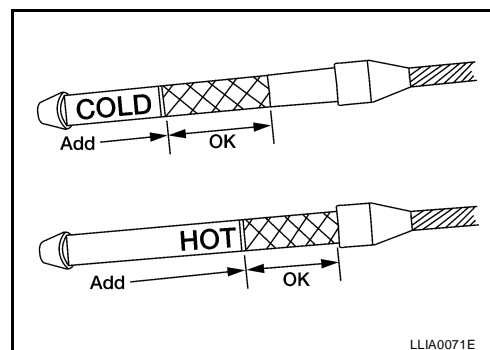

8. Install the A/T fluid level gauge in the A/T fluid charging pipe and install the A/T fluid level gauge bolt.
9. Tighten the A/T fluid level gauge bolt to specification.

**A/T fluid level gauge bolt** : Refer to [AT-242, "Components"](#).

## A/T Fluid Cooler Cleaning

Whenever an A/T is repaired, overhauled, or replaced, the A/T fluid cooler mounted in the radiator must be inspected and cleaned.

Metal debris and friction material, if present, can become trapped in the A/T fluid cooler. This debris can contaminate the newly serviced A/T or, in severe cases, can block or restrict the flow of A/T fluid. In either case, malfunction of the newly serviced A/T may result.

Debris, if present, may build up as A/T fluid enters the cooler inlet. It will be necessary to back flush the cooler through the cooler outlet in order to flush out any built up debris.

### A/T FLUID COOLER CLEANING PROCEDURE

1. Position a drain pan under the A/T inlet and outlet fluid cooler tube to cooler hose connection.
2. Put a different color matching mark on each cooler tube to cooler hose connection to aid in assembly.

**CAUTION:**

**Use paint to make the matching mark. Do not damage the tubes or hose.**

3. Disconnect the fluid cooler inlet and outlet rubber hoses from the steel cooler tubes.

**NOTE:**

Replace the cooler hoses if rubber material from the hose remains on the tube fitting.

4. Drain any A/T fluid from the cooler hose.

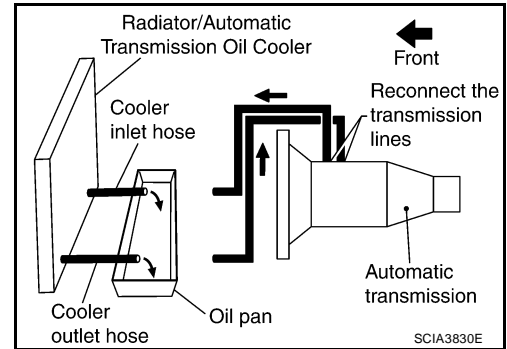

5. Insert the extension adapter hose of a can of Transmission Cooler Cleaner (Nissan P/N 999MP-AM006) into the cooler outlet hose.

**CAUTION:**

- Wear safety glasses and rubber gloves when spraying the Transmission Cooler Cleaner.
- Spray cooler cleaner only with adequate ventilation.
- Avoid contact with eyes and skin.
- Do not breath vapors or spray mist.

6. Hold the hose and can as high as possible and spray Transmission Cooler Cleaner in a continuous stream into the cooler outlet hose until fluid flows out of the cooler inlet hose for 5 seconds.

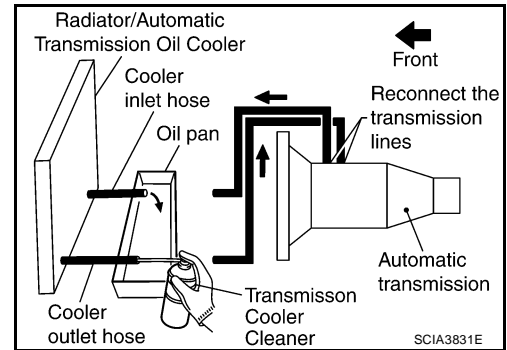

7. Insert the tip of an air gun into the end of the cooler outlet hose.
8. Wrap a shop rag around the tip of the air gun and the cooler outlet hose.

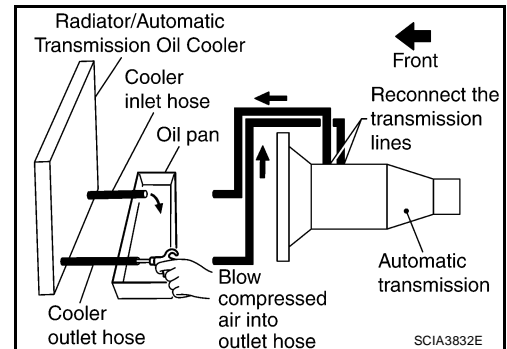

9. Blow compressed air regulated to 5 - 9 kg/cm<sup>2</sup> (70 - 130 psi) through the cooler outlet hose for 10 seconds to force out any remaining fluid.
10. Repeat steps 5 through 9 three additional times.
11. Position an oil pan under the banjo bolts that connect the fluid cooler tubes to the A/T.
12. Remove the banjo bolts.

## A/T FLUID

- Flush each steel line from the cooler side back toward the A/T by spraying Transmission Cooler Cleaner in a continuous stream for 5 seconds.
- Blow compressed air regulated to 5 - 9 kg/cm<sup>2</sup> (70 - 130 psi) through each steel line from the cooler side back toward the A/T for 10 seconds to force out any remaining fluid.
- Ensure all debris is removed from the steel cooler lines.
- Ensure all debris is removed from the banjo bolts and fittings.
- Perform [AT-16, "A/T FLUID COOLER DIAGNOSIS PROCEDURE"](#).

### A/T FLUID COOLER DIAGNOSIS PROCEDURE

#### NOTE:

Insufficient cleaning of the cooler inlet hose exterior may lead to inaccurate debris identification.

- Position a drain pan under the A/T inlet and outlet fluid cooler tube to cooler hose connection.
- Clean the exterior and tip of the cooler inlet hose.
- Put a different color matching mark on each cooler tube to cooler hose connection to aid in assembly.

#### CAUTION:

**Use paint to make the matching mark. Do not damage the tubes or hose.**

- Disconnect the fluid cooler inlet and outlet rubber hoses from the steel cooler tubes.

#### NOTE:

Replace the cooler hoses if rubber material from the hose remains on the tube fitting.

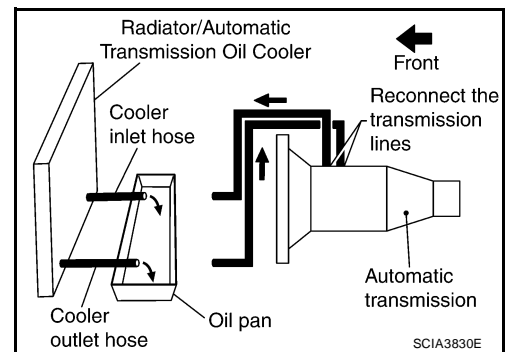

- Insert the extension adapter hose of a can of Transmission Cooler Cleaner (Nissan P/N 999MP-AM006) into the cooler outlet hose.

#### CAUTION:

- **Wear safety glasses and rubber gloves when spraying the Transmission Cooler Cleaner.**
- **Spray cooler cleaner only with adequate ventilation.**
- **Avoid contact with eyes and skin.**
- **Do not breath vapors or spray mist.**

- Hold the hose and can as high as possible and spray Transmission Cooler Cleaner in a continuous stream into the cooler outlet hose until fluid flows out of the cooler inlet hose for 5 seconds.
- Tie a common white, basket-type coffee filter to the end of the cooler inlet hose.

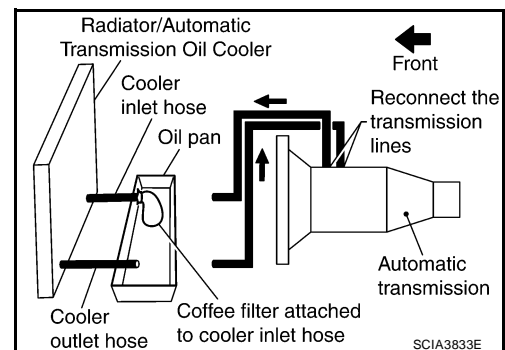
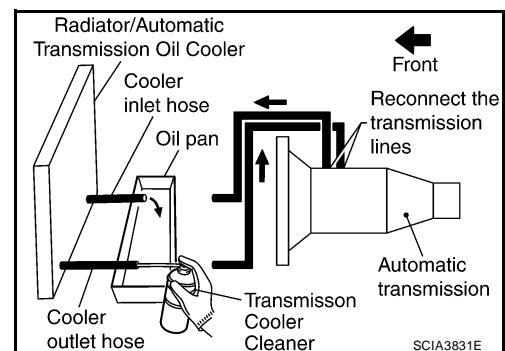



# A/T FLUID

8. Insert the tip of an air gun into the end of the cooler outlet hose.
9. Wrap a shop rag around the air gun tip and end of cooler outlet hose.
10. Blow compressed air regulated to 5 - 9 kg/cm<sup>2</sup> (70 - 130 psi) through the cooler outlet hose to force any remaining A/T fluid into the coffee filter.
11. Remove the coffee filter from the end of the cooler inlet hose.
12. Perform A/T fluid cooler inspection. Refer to [AT-17, "A/T FLUID COOLER INSPECTION PROCEDURE"](#).

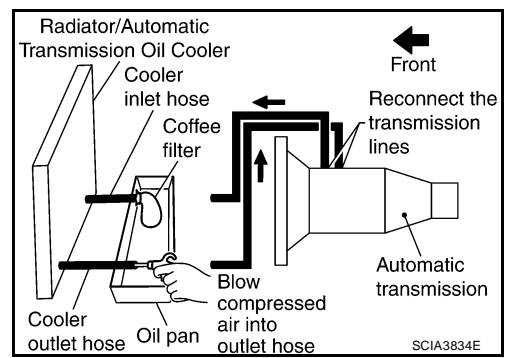

## A/T FLUID COOLER INSPECTION PROCEDURE

1. Inspect the coffee filter for debris.
  - a. If small metal debris less than 1mm (0.040 in) in size or metal powder is found in the coffee filter, this is normal. If normal debris is found, the A/T fluid cooler/radiator can be re-used and the procedure is ended.
  - b. If one or more pieces of debris are found that are over 1mm (0.040 in) in size and/or peeled clutch facing material is found in the coffee filter, the fluid cooler is not serviceable. The A/T fluid cooler/radiator must be replaced and the inspection procedure is ended. Refer to [CO-42, "RADIATOR"](#).

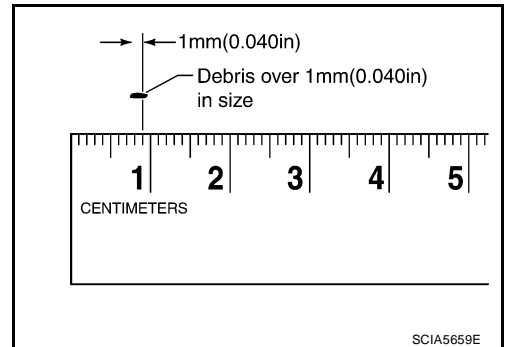
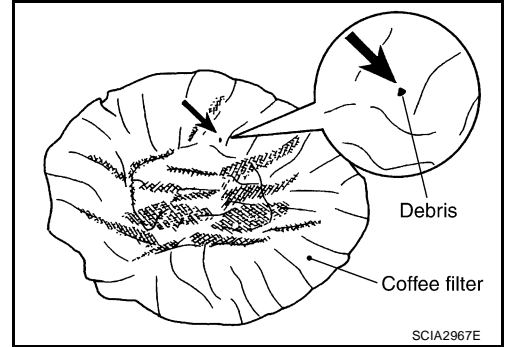

## A/T FLUID COOLER FINAL INSPECTION

After performing all procedures, ensure that all remaining oil is cleaned from all components.

# A/T CONTROL SYSTEM

## A/T CONTROL SYSTEM

PF3:31036

### Cross-Sectional View

UCS0041M

#### 2WD Models

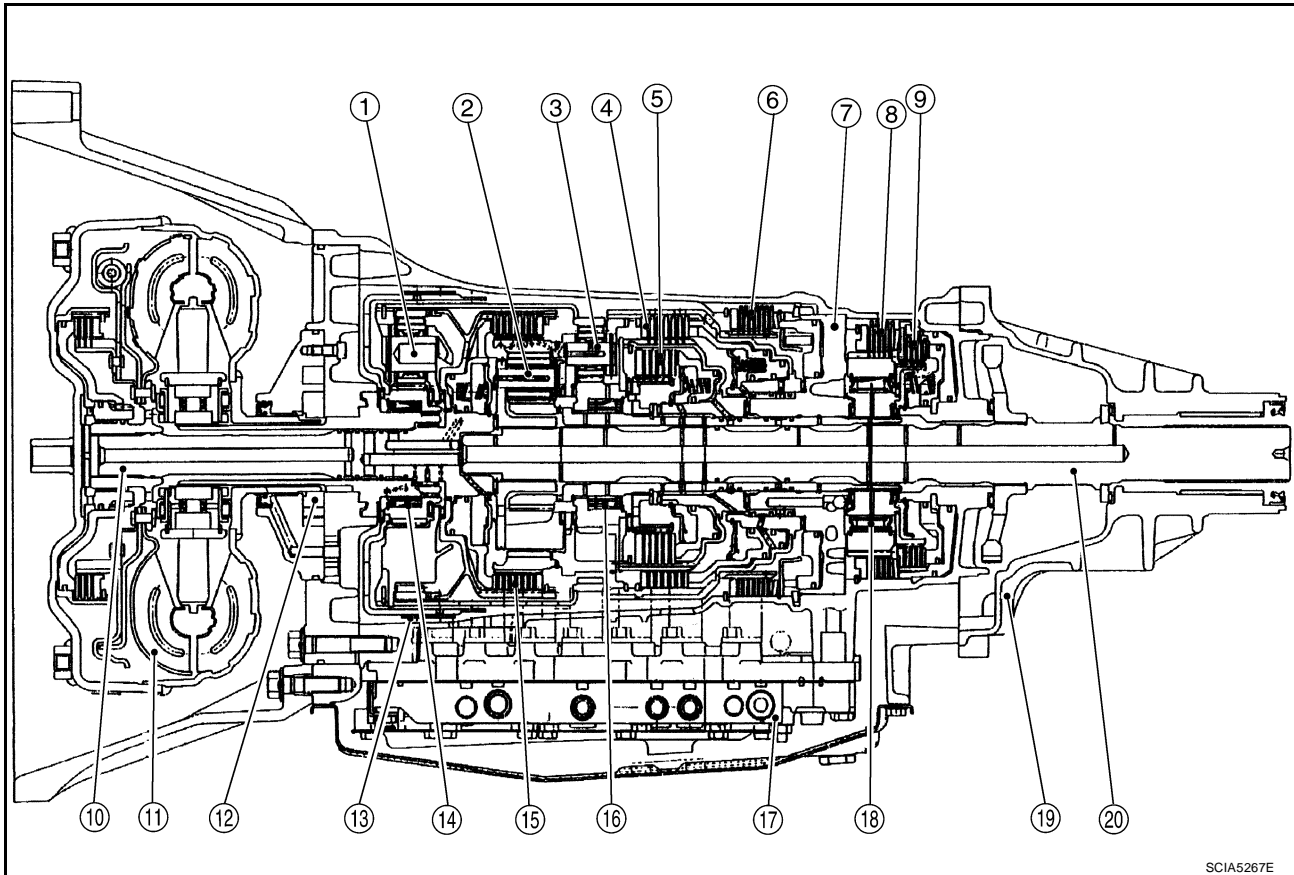

SCIA5267E

- |                         |                                |                            |
|-------------------------|--------------------------------|----------------------------|
| 1. Front planetary gear | 2. Mid planetary gear          | 3. Rear planetary gear     |
| 4. Direct clutch        | 5. High and low reverse clutch | 6. Reverse brake           |
| 7. Drum support         | 8. Forward brake               | 9. Low coast brake         |
| 10. Input shaft         | 11. Torque converter           | 12. Oil pump               |
| 13. Front brake         | 14. 3rd one-way clutch         | 15. Input clutch           |
| 16. 1st one-way clutch  | 17. Control valve with TCM     | 18. Forward one-way clutch |
| 19. Rear extension      | 20. Output shaft               |                            |

# A/T CONTROL SYSTEM

## 4WD Models

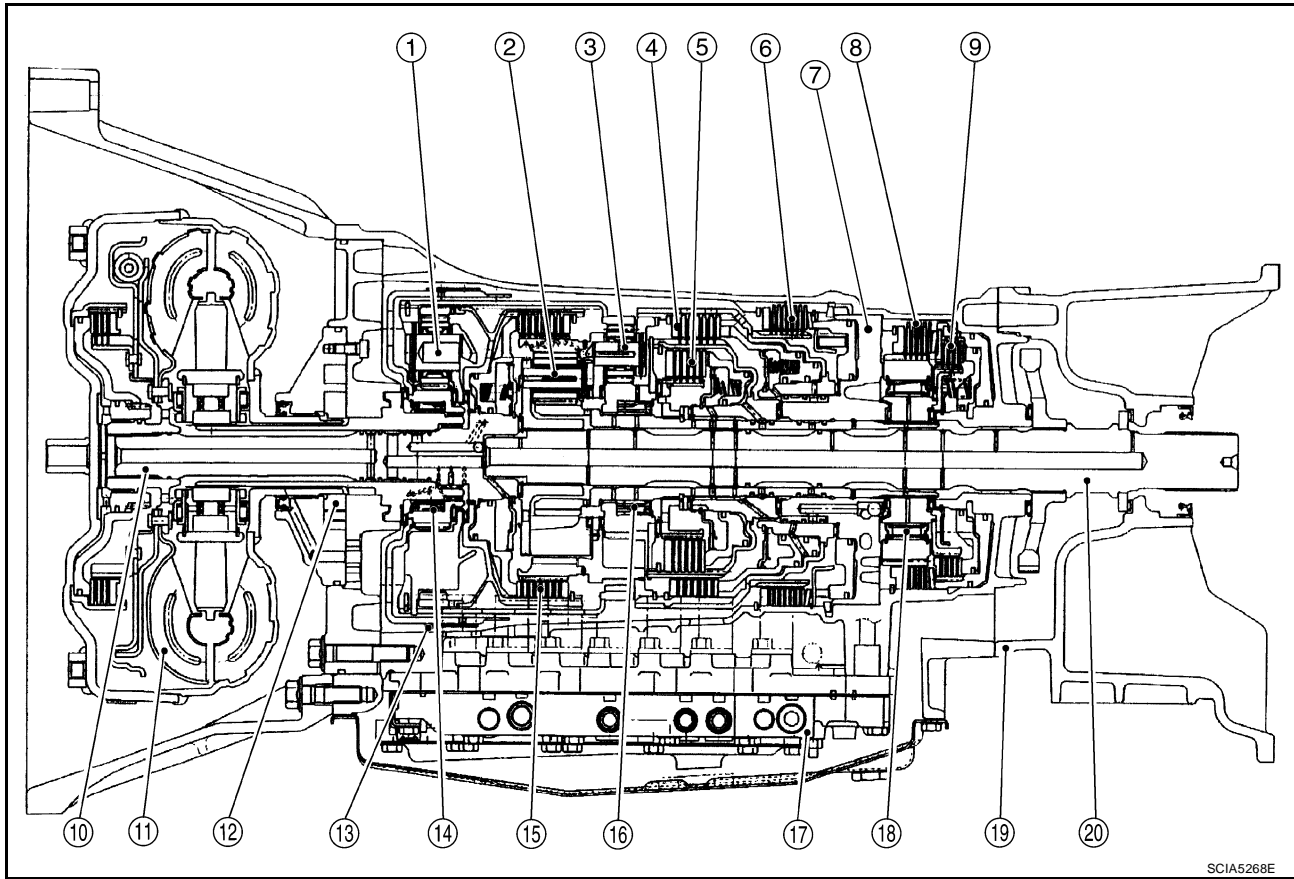

- |                         |                                |                            |
|-------------------------|--------------------------------|----------------------------|
| 1. Front planetary gear | 2. Mid planetary gear          | 3. Rear planetary gear     |
| 4. Direct clutch        | 5. High and low reverse clutch | 6. Reverse brake           |
| 7. Drum support         | 8. Forward brake               | 9. Low coast brake         |
| 10. Input shaft         | 11. Torque converter           | 12. Oil pump               |
| 13. Front brake         | 14. 3rd one-way clutch         | 15. Input clutch           |
| 16. 1st one-way clutch  | 17. Control valve with TCM     | 18. Forward one-way clutch |
| 19. Adapter case        | 20. Output shaft               |                            |

# A/T CONTROL SYSTEM

UCS0041N

## Shift Mechanism

The automatic transmission uses compact triple planetary gear systems to improve power-transmission efficiency, simplify construction and reduce weight. It also employs an optimum shift control and super wide gear ratios. They improve starting performance and acceleration during medium and high-speed operation.

## CONSTRUCTION

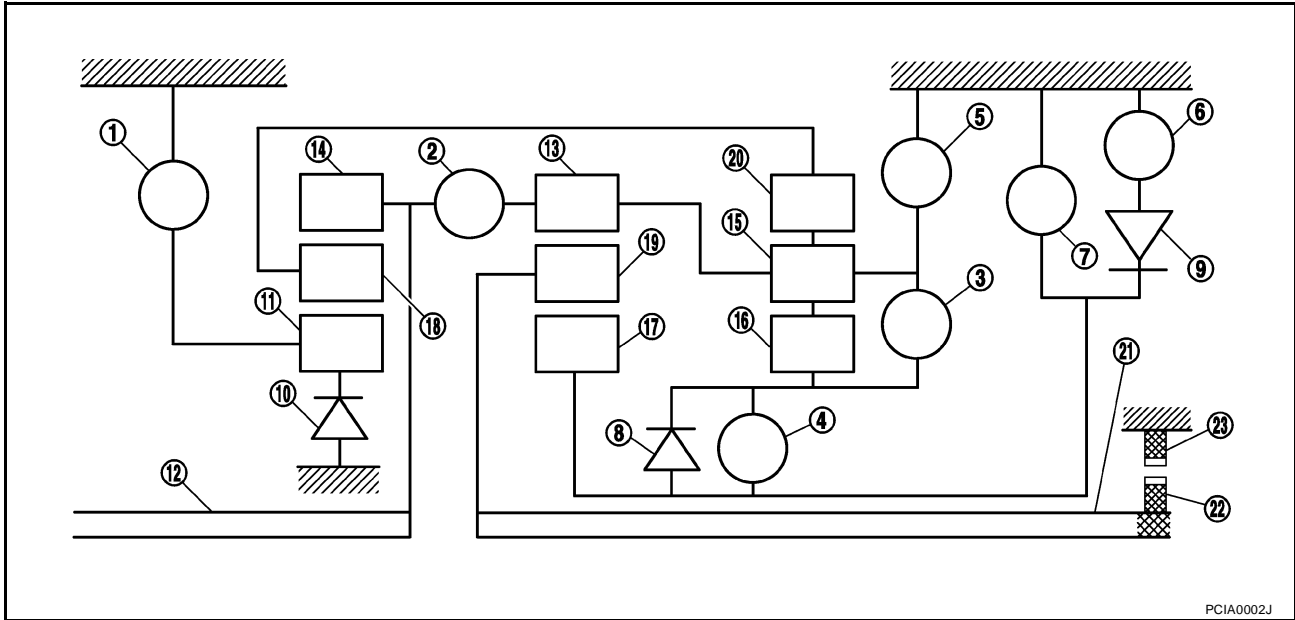

PCIA0002J

- |                                |                         |                           |
|--------------------------------|-------------------------|---------------------------|
| 1. Front brake                 | 2. Input clutch         | 3. Direct clutch          |
| 4. High and low reverse clutch | 5. Reverse brake        | 6. Forward brake          |
| 7. Low coast brake             | 8. 1st one-way clutch   | 9. Forward one-way clutch |
| 10. 3rd one-way clutch         | 11. Front sun gear      | 12. Input shaft           |
| 13. Mid internal gear          | 14. Front internal gear | 15. Rear carrier          |
| 16. Rear sun gear              | 17. Mid sun gear        | 18. Front carrier         |
| 19. Mid carrier                | 20. Rear internal gear  | 21. Output shaft          |
| 22. Parking gear               | 23. Parking pawl        |                           |

## FUNCTION OF CLUTCH AND BRAKE

Name of the Part	Abbreviation	Function
Front brake (1)	FR/B	Fastens the front sun gear (11).
Input clutch (2)	I/C	Connects the input shaft (12), the front internal gear (14) and the mid internal gear (13).
Direct clutch (3)	D/C	Connects the rear carrier (15) and the rear sun gear (16).
High and low reverse clutch (4)	HLR/C	Connects the mid sun gear (17) and the rear sun gear (16).
Reverse brake (5)	R/B	Fastens the rear carrier (15).
Forward brake (6)	Fwd/B	Fastens the mid sun gear (17).
Low coast brake (7)	LC/B	Fastens the mid sun gear (17).
1st one-way clutch (8)	1st WOC	Allows the rear sun gear (16) to turn freely forward relative to the mid sun gear (17) but fastens it for reverse rotation.
Forward one-way clutch (9)	Fwd OWC	Allows the mid sun gear (17) to turn freely in the forward direction but fastens it for reverse rotation.
3rd one-way clutch (10)	3rd OWC	Allows the front sun gear (11) to turn freely in the forward direction but fastens it for reverse rotation.

# A/T CONTROL SYSTEM

## CLUTCH AND BAND CHART

Shift position	I/C	HLR/C	D/C	R/B	FR/B	LC/B	Fwd/B	1st OWC	Fwd OWC	3rd OWC	Remarks
P		△			△						PARK POSITION
R		○		○	○			☆		☆	REVERSE POSITION
N		△			△						NEUTRAL POSITION
D*1	1st	△*			△	△**	○	☆	☆	☆	Automatic shift 1↔2↔3↔4↔5
	2nd		○		△		○		☆	☆	
	3rd	○	○		○		△	★		☆	
	4th	○	○	○			△	★			
	5th	○	○			○		△	★	★	
3	1st	△*			△	△**	○	☆	☆	☆	Automatic shift 1↔2↔3↔4
	2nd		○		△		○		☆	☆	
	3rd	○	○		○		△	★		☆	
	4th	○	○	○			△	★			
2	1st	△*			△	△**	○	☆	☆	☆	Automatic shift 1↔2↔3↔4
	2nd		○		○	○	○		☆	☆	
	3rd	○	○		○		△	★		☆	
	4th	○	○	○			△	★			
1	1st	○			○	○	○	☆	☆	☆	Locks (held stationary in 1st gear) 1↔2↔3↔4
	2nd		○		○	○	○		☆	☆	
	3rd	○	○		○		△	★		☆	
	4th	○	○	○			△	★			

- ○—Operates
- ☆—Operates during “progressive” acceleration.
- ★—Operates and effects power transmission while coasting.
- △—Line pressure is applied but does not affect power transmission.
- △\*—Operates under conditions shown in HLR/C Operating Condition
- △\*\*—Operates under conditions shown in LC/B Operating Condition. Delay control is applied during D (4,3,2,1) ⇒N shift.
- \*1: A/T will not shift to 5th when overdrive control switch is set in “OFF” position.

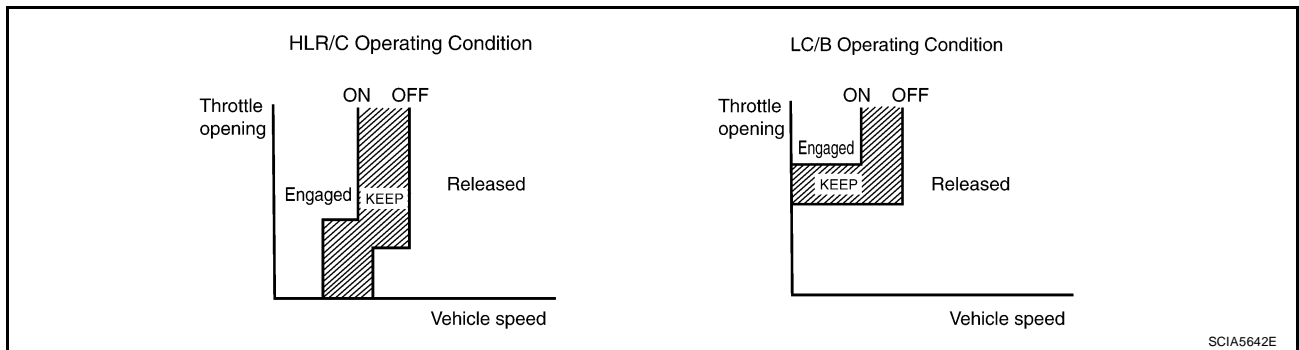

# A/T CONTROL SYSTEM

## POWER TRANSMISSION

### “N” Position

Since both the forward brake and the reverse brake are released, torque from the input shaft drive is not transmitted to the output shaft.

### “P” Position

- The same as for the “N” position, both the forward brake and the reverse brake are released, so torque from the input shaft drive is not transmitted to the output shaft.
- The parking pawl linked with the select lever meshes with the parking gear and fastens the output shaft mechanically.

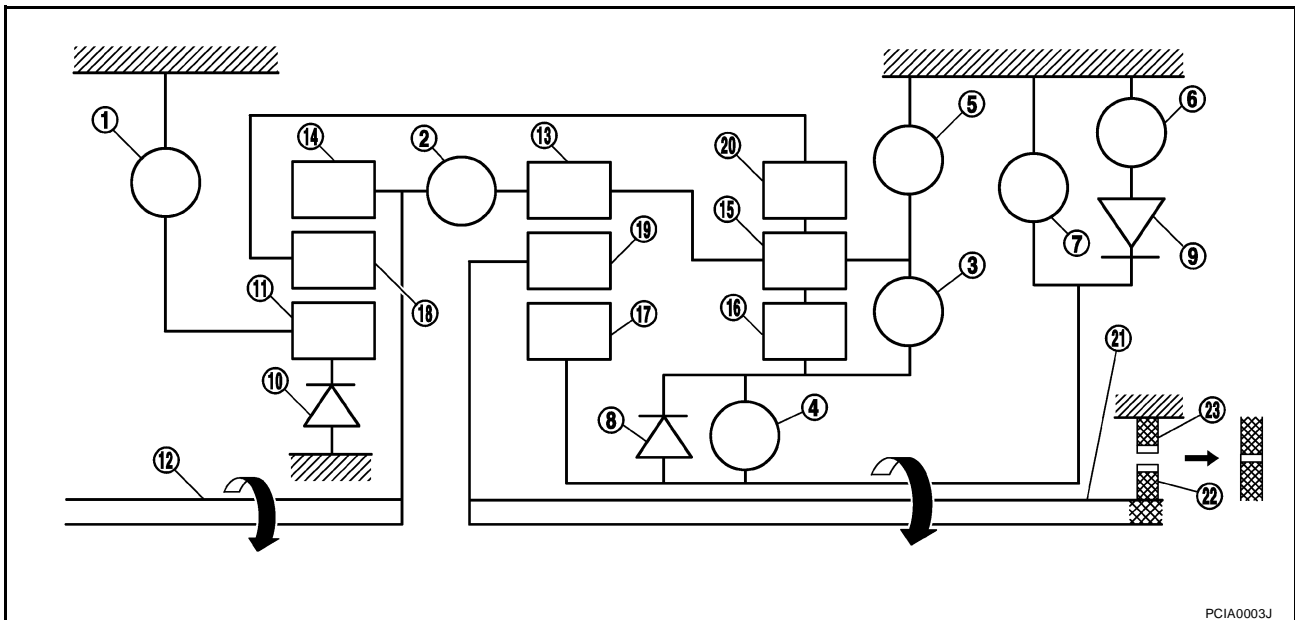

- |                                |                         |                           |
|--------------------------------|-------------------------|---------------------------|
| 1. Front brake                 | 2. Input clutch         | 3. Direct clutch          |
| 4. High and low reverse clutch | 5. Reverse brake        | 6. Forward brake          |
| 7. Low coast brake             | 8. 1st one-way clutch   | 9. Forward one-way clutch |
| 10. 3rd one-way clutch         | 11. Front sun gear      | 12. Input shaft           |
| 13. Mid internal gear          | 14. Front internal gear | 15. Rear carrier          |
| 16. Rear sun gear              | 17. Mid sun gear        | 18. Front carrier         |
| 19. Mid carrier                | 20. Rear internal gear  | 21. Output shaft          |
| 22. Parking gear               | 23. Parking pawl        |                           |

# A/T CONTROL SYSTEM

## “D”, “3” and “2” Positions 1st Gear

- The forward brake and the forward one-way clutch regulate reverse rotation of the mid sun gear.
- The 1st one-way clutch regulates reverse rotation of the rear sun gear.
- The 3rd one-way clutch regulates reverse rotation of the front sun gear.
- During deceleration, the mid sun gear turns forward, so the forward one-way clutch idles and the engine brake is not activated.

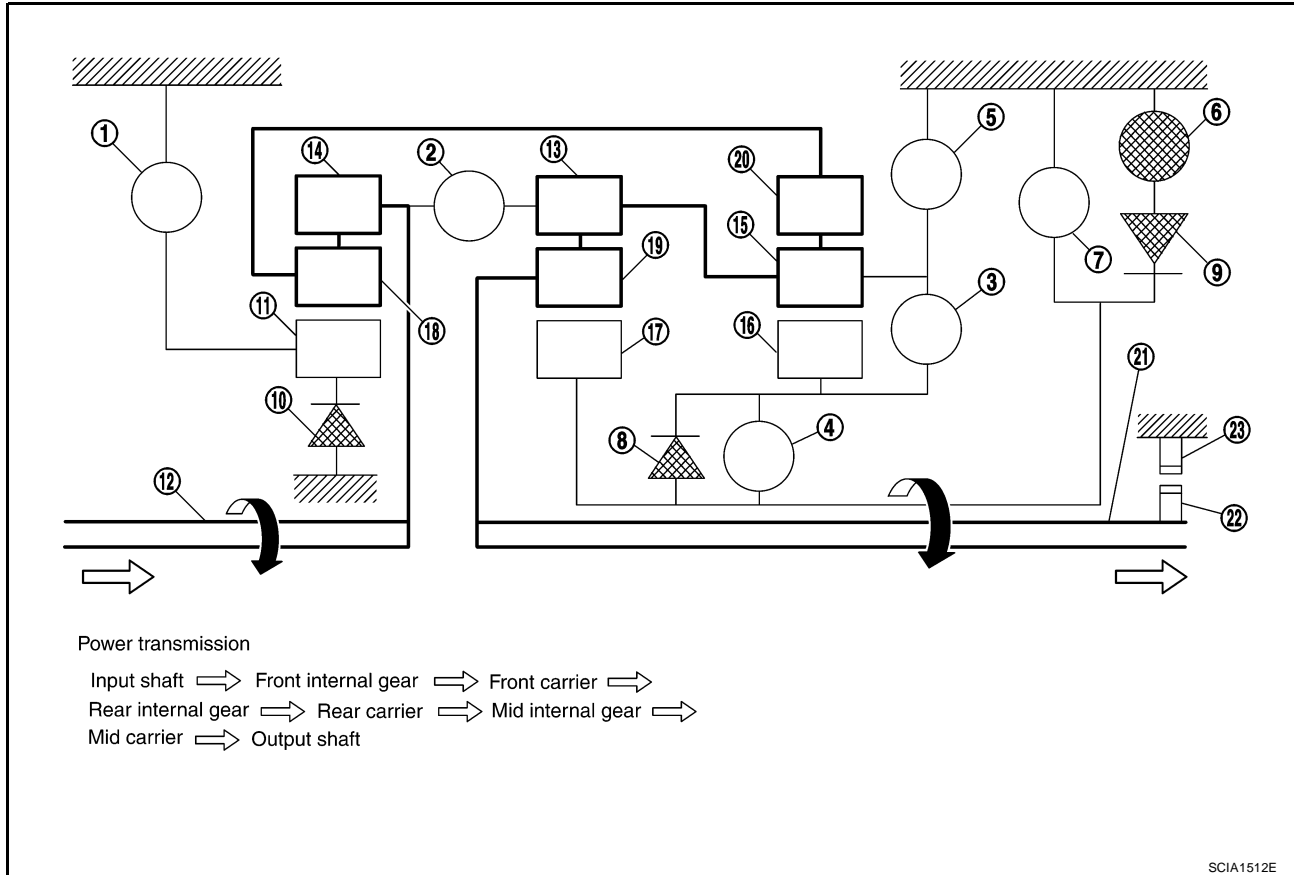

- |                                |                         |                           |
|--------------------------------|-------------------------|---------------------------|
| 1. Front brake                 | 2. Input clutch         | 3. Direct clutch          |
| 4. High and low reverse clutch | 5. Reverse brake        | 6. Forward brake          |
| 7. Low coast brake             | 8. 1st one-way clutch   | 9. Forward one-way clutch |
| 10. 3rd one-way clutch         | 11. Front sun gear      | 12. Input shaft           |
| 13. Mid internal gear          | 14. Front internal gear | 15. Rear carrier          |
| 16. Rear sun gear              | 17. Mid sun gear        | 18. Front carrier         |
| 19. Mid carrier                | 20. Rear internal gear  | 21. Output shaft          |
| 22. Parking gear               | 23. Parking pawl        |                           |

SCIA1512E

# A/T CONTROL SYSTEM

## "1" Position 1st Gear

- The front brake fastens the front sun gear.
- The forward brake and the forward one-way clutch regulate reverse rotation of the mid sun gear.
- High and low reverse clutch connects the rear sun gear and the mid sun gear.
- The low coast brake fastens the mid sun gear.
- During deceleration, the low coast brake regulates forward rotation of the mid sun gear and the engine brake functions.

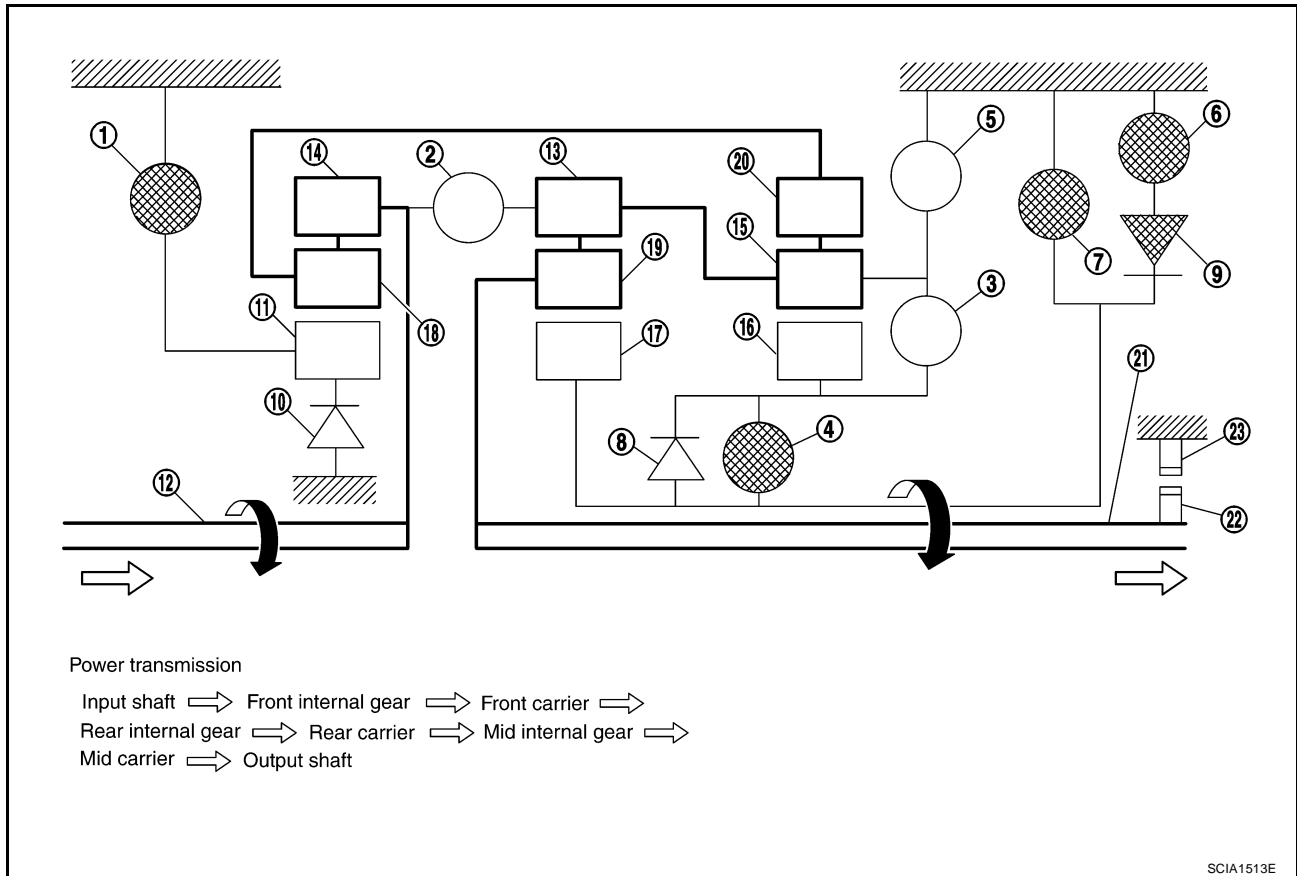

- |                                |                         |                           |
|--------------------------------|-------------------------|---------------------------|
| 1. Front brake                 | 2. Input clutch         | 3. Direct clutch          |
| 4. High and low reverse clutch | 5. Reverse brake        | 6. Forward brake          |
| 7. Low coast brake             | 8. 1st one-way clutch   | 9. Forward one-way clutch |
| 10. 3rd one-way clutch         | 11. Front sun gear      | 12. Input shaft           |
| 13. Mid internal gear          | 14. Front internal gear | 15. Rear carrier          |
| 16. Rear sun gear              | 17. Mid sun gear        | 18. Front carrier         |
| 19. Mid carrier                | 20. Rear internal gear  | 21. Output shaft          |
| 22. Parking gear               | 23. Parking pawl        |                           |



# A/T CONTROL SYSTEM

## “D” and “3” Positions 2nd Gear

- The forward brake and the forward one-way clutch regulate reverse rotation of the mid sun gear.
- The 3rd one-way clutch regulates reverse rotation of the front sun gear.
- The direct clutch is coupled and the rear carrier and rear sun gear are connected.
- During deceleration, the mid sun gear turns forward, so the forward one-way clutch idles and engine brake is not activated.

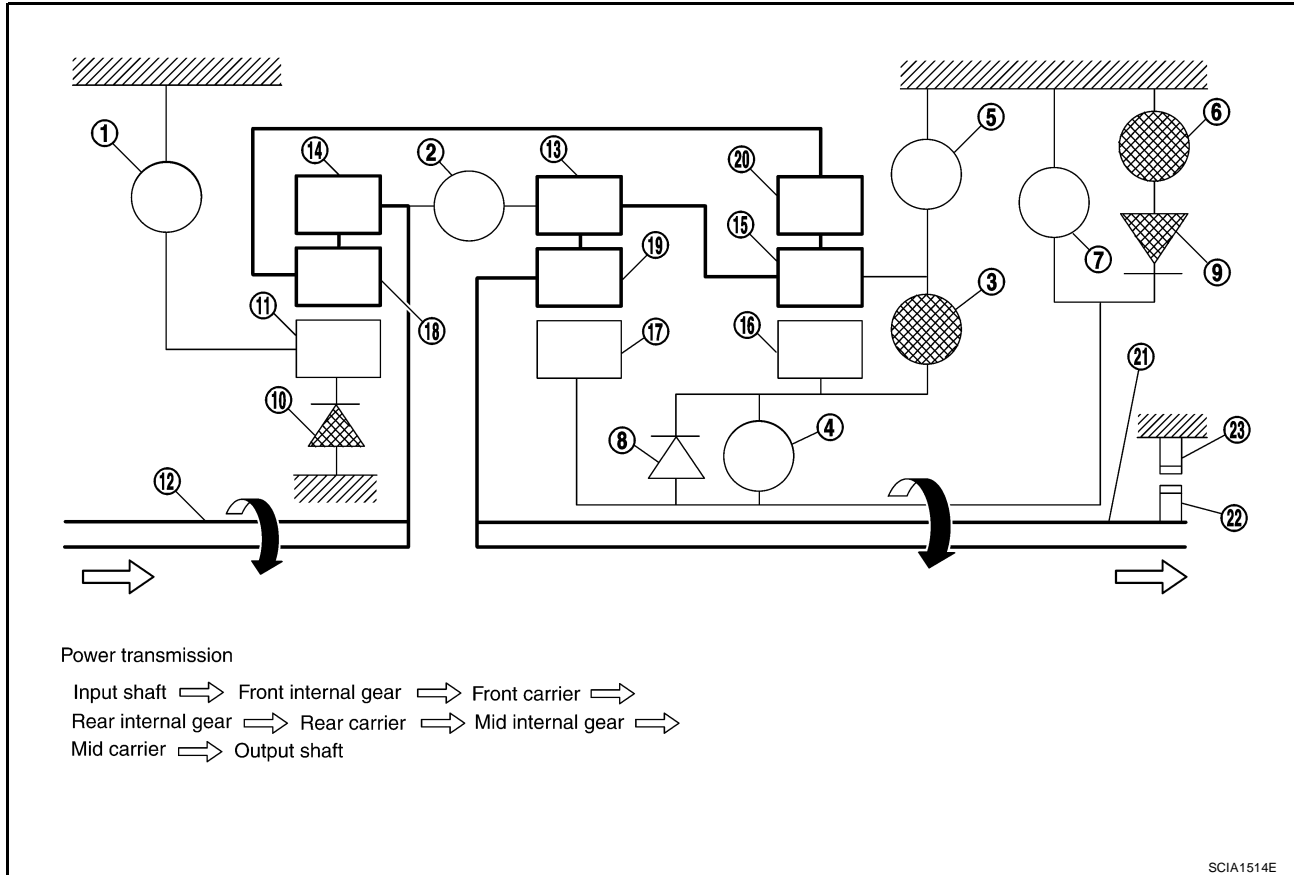

- |                                |                         |                           |
|--------------------------------|-------------------------|---------------------------|
| 1. Front brake                 | 2. Input clutch         | 3. Direct clutch          |
| 4. High and low reverse clutch | 5. Reverse brake        | 6. Forward brake          |
| 7. Low coast brake             | 8. 1st one-way clutch   | 9. Forward one-way clutch |
| 10. 3rd one-way clutch         | 11. Front sun gear      | 12. Input shaft           |
| 13. Mid internal gear          | 14. Front internal gear | 15. Rear carrier          |
| 16. Rear sun gear              | 17. Mid sun gear        | 18. Front carrier         |
| 19. Mid carrier                | 20. Rear internal gear  | 21. Output shaft          |
| 22. Parking gear               | 23. Parking pawl        |                           |

# A/T CONTROL SYSTEM

## “2” and “1” Positions 2nd Gear

- The front brake fastens the front sun gear.
- The forward brake and the forward one-way clutch regulate reverse rotation of the mid sun gear.
- The direct clutch is coupled, and the rear carrier and rear sun gear are connected.
- The low coast brake fastens the mid sun gear.
- During deceleration, the low coast brake regulates forward rotation of the mid sun gear and the engine brake functions.

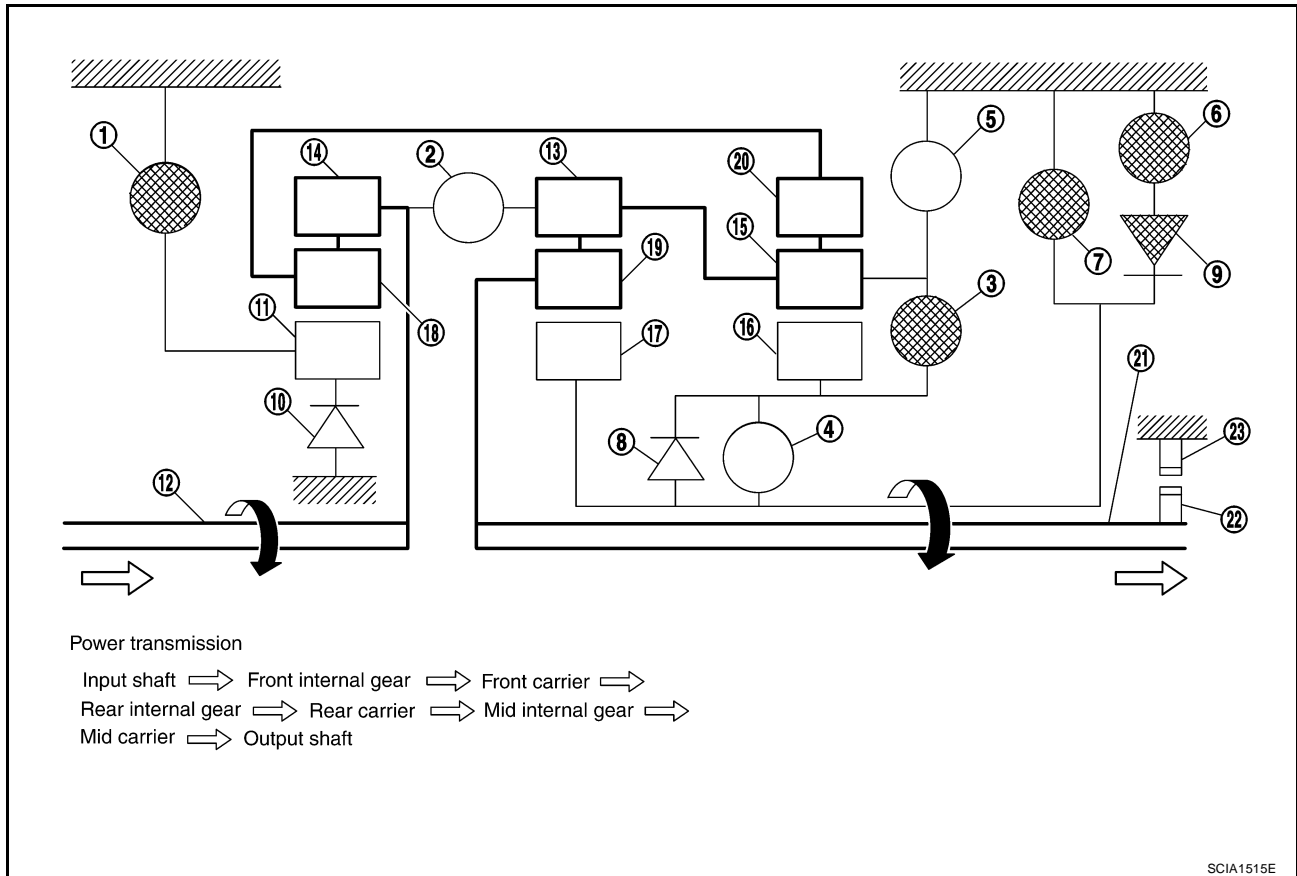

- |                                |                         |                           |
|--------------------------------|-------------------------|---------------------------|
| 1. Front brake                 | 2. Input clutch         | 3. Direct clutch          |
| 4. High and low reverse clutch | 5. Reverse brake        | 6. Forward brake          |
| 7. Low coast brake             | 8. 1st one-way clutch   | 9. Forward one-way clutch |
| 10. 3rd one-way clutch         | 11. Front sun gear      | 12. Input shaft           |
| 13. Mid internal gear          | 14. Front internal gear | 15. Rear carrier          |
| 16. Rear sun gear              | 17. Mid sun gear        | 18. Front carrier         |
| 19. Mid carrier                | 20. Rear internal gear  | 21. Output shaft          |
| 22. Parking gear               | 23. Parking pawl        |                           |

# A/T CONTROL SYSTEM

## “D” and “3” Positions 3rd Gear

- The front brake fastens the front sun gear.
- The direct clutch is coupled, and the rear carrier and rear sun gear are connected.
- The high and low reverse clutch is coupled and the mid sun gear and rear sun gear are connected.

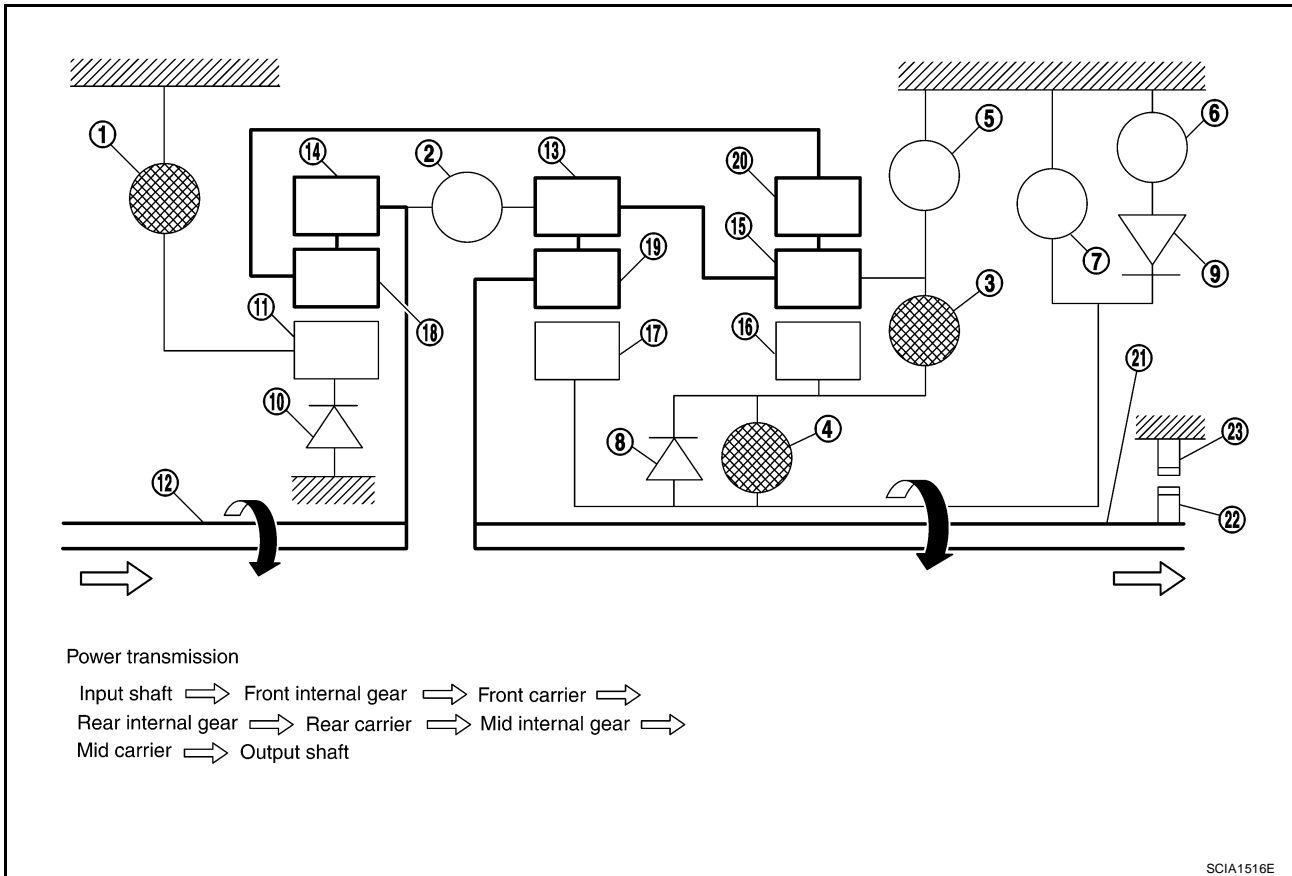

- |                                |                         |                           |
|--------------------------------|-------------------------|---------------------------|
| 1. Front brake                 | 2. Input clutch         | 3. Direct clutch          |
| 4. High and low reverse clutch | 5. Reverse brake        | 6. Forward brake          |
| 7. Low coast brake             | 8. 1st one-way clutch   | 9. Forward one-way clutch |
| 10. 3rd one-way clutch         | 11. Front sun gear      | 12. Input shaft           |
| 13. Mid internal gear          | 14. Front internal gear | 15. Rear carrier          |
| 16. Rear sun gear              | 17. Mid sun gear        | 18. Front carrier         |
| 19. Mid carrier                | 20. Rear internal gear  | 21. Output shaft          |
| 22. Parking gear               | 23. Parking pawl        |                           |

# A/T CONTROL SYSTEM

## “D” Position 4th Gear

- The direct clutch is coupled, and the rear carrier and rear sun gear are connected.
- The high and low reverse clutch is coupled and the mid sun gear and rear sun gear are connected.
- The input clutch is coupled and the front internal gear and mid internal gear are connected.
- The drive power is conveyed to the front internal gear, mid internal gear, and rear carrier and the three planetary gears rotate forward as one unit.

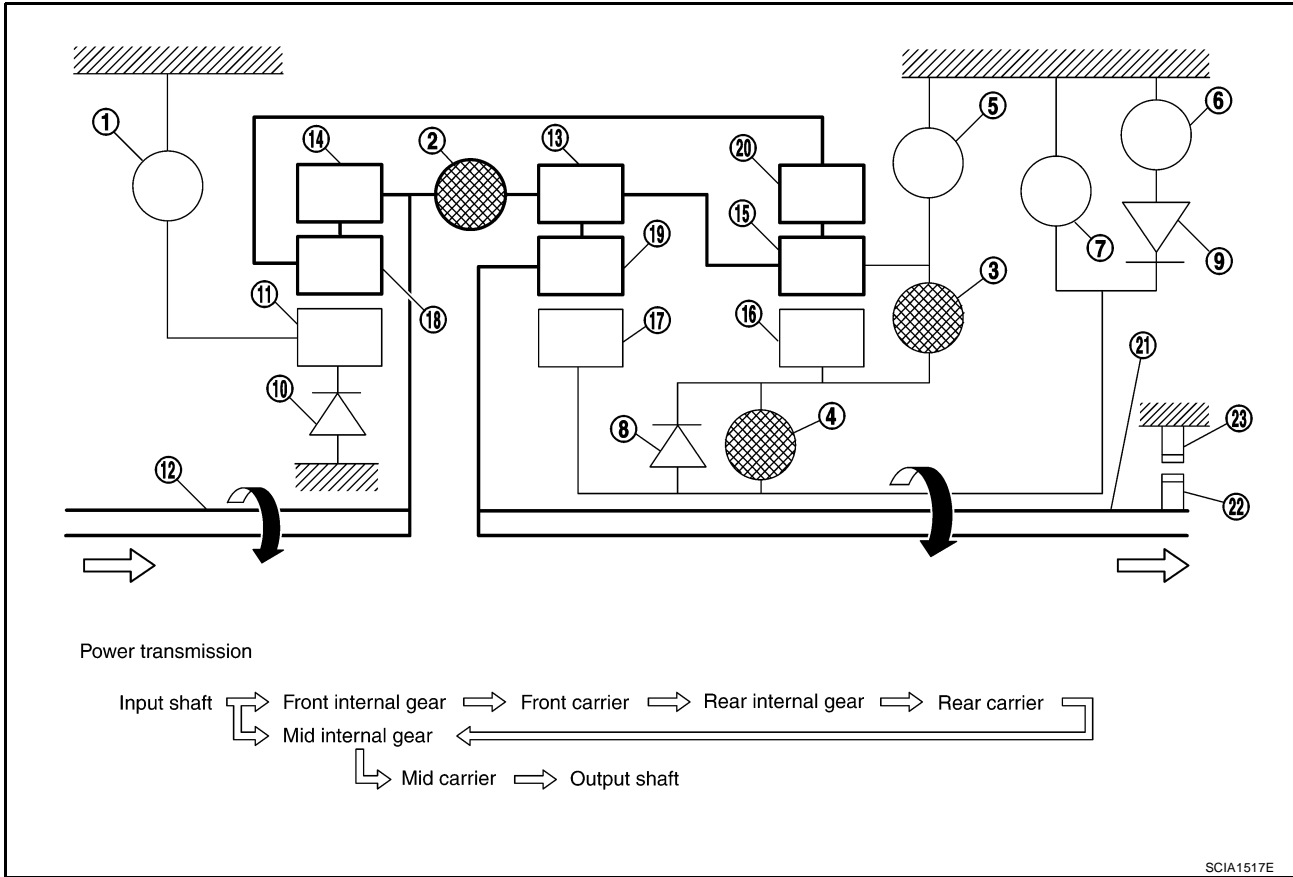

SCIA1517E

- |                                |                         |                           |
|--------------------------------|-------------------------|---------------------------|
| 1. Front brake                 | 2. Input clutch         | 3. Direct clutch          |
| 4. High and low reverse clutch | 5. Reverse brake        | 6. Forward brake          |
| 7. Low coast brake             | 8. 1st one-way clutch   | 9. Forward one-way clutch |
| 10. 3rd one-way clutch         | 11. Front sun gear      | 12. Input shaft           |
| 13. Mid internal gear          | 14. Front internal gear | 15. Rear carrier          |
| 16. Rear sun gear              | 17. Mid sun gear        | 18. Front carrier         |
| 19. Mid carrier                | 20. Rear internal gear  | 21. Output shaft          |
| 22. Parking gear               | 23. Parking pawl        |                           |

# A/T CONTROL SYSTEM

## “D” Position 5th Gear

- The front brake fastens the front sun gear.
- The input clutch is coupled and the front internal gear and mid internal gear are connected.
- The high and low reverse clutch is coupled and the mid sun gear and rear sun gear are connected.

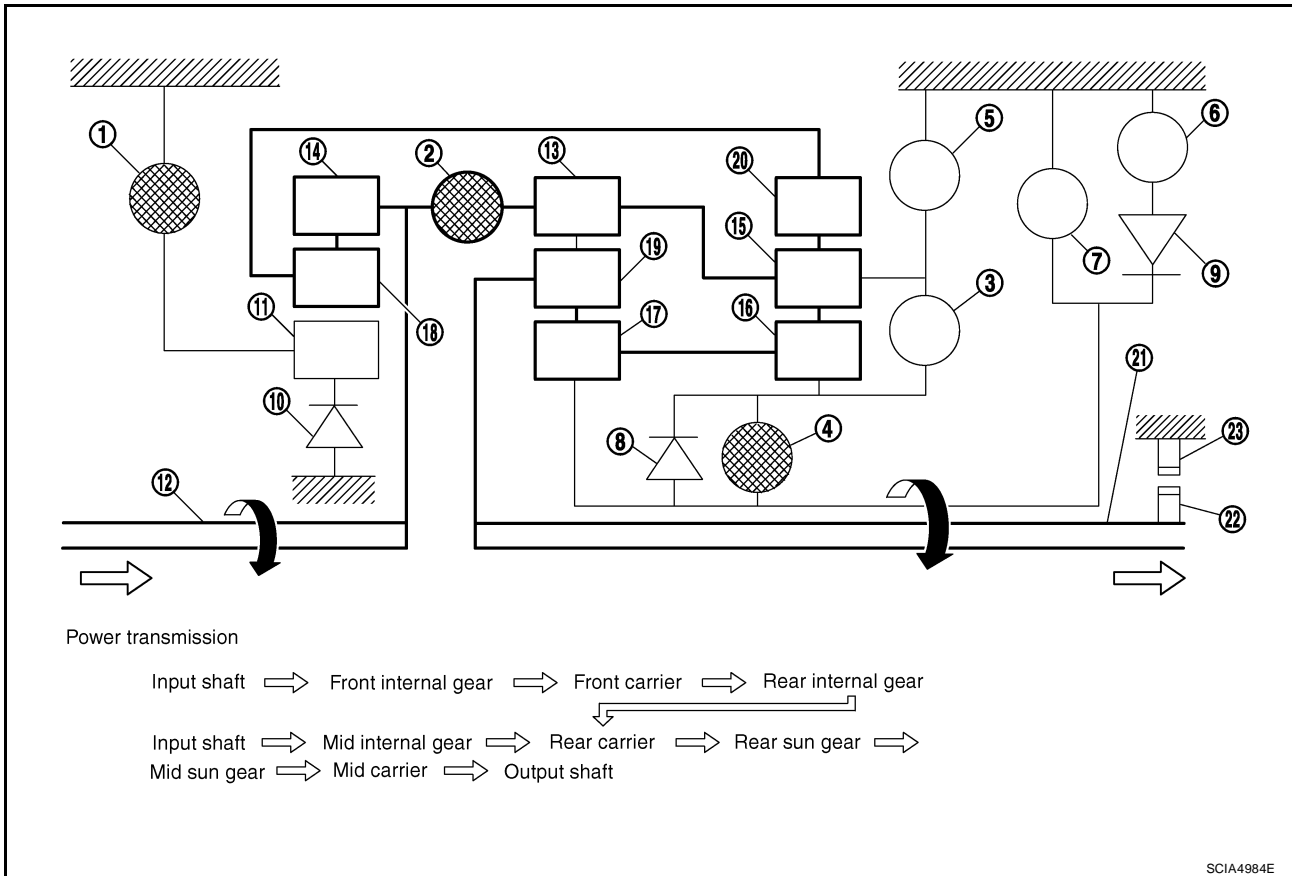

- |                                |                         |                           |
|--------------------------------|-------------------------|---------------------------|
| 1. Front brake                 | 2. Input clutch         | 3. Direct clutch          |
| 4. High and low reverse clutch | 5. Reverse brake        | 6. Forward brake          |
| 7. Low coast brake             | 8. 1st one-way clutch   | 9. Forward one-way clutch |
| 10. 3rd one-way clutch         | 11. Front sun gear      | 12. Input shaft           |
| 13. Mid internal gear          | 14. Front internal gear | 15. Rear carrier          |
| 16. Rear sun gear              | 17. Mid sun gear        | 18. Front carrier         |
| 19. Mid carrier                | 20. Rear internal gear  | 21. Output shaft          |
| 22. Parking gear               | 23. Parking pawl        |                           |

# A/T CONTROL SYSTEM

## “R” Position

- The front brake fastens the front sun gear.
- The high and low reverse clutch is coupled, and the mid sun gear and rear sun gear are connected.
- The reverse brake fastens the rear carrier.

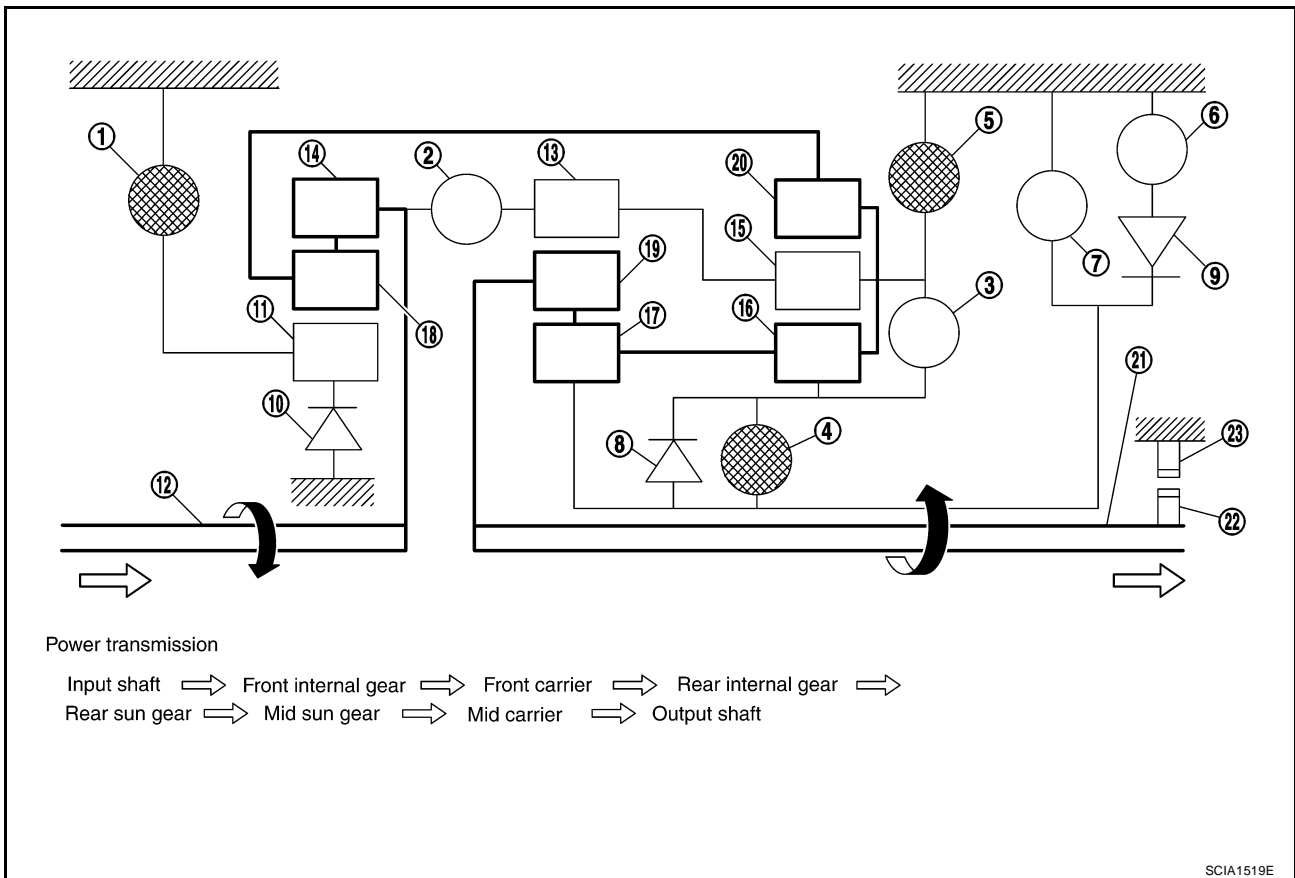

- |                                |                         |                           |
|--------------------------------|-------------------------|---------------------------|
| 1. Front brake                 | 2. Input clutch         | 3. Direct clutch          |
| 4. High and low reverse clutch | 5. Reverse brake        | 6. Forward brake          |
| 7. Low coast brake             | 8. 1st one-way clutch   | 9. Forward one-way clutch |
| 10. 3rd one-way clutch         | 11. Front sun gear      | 12. Input shaft           |
| 13. Mid internal gear          | 14. Front internal gear | 15. Rear carrier          |
| 16. Rear sun gear              | 17. Mid sun gear        | 18. Front carrier         |
| 19. Mid carrier                | 20. Rear internal gear  | 21. Output shaft          |
| 22. Parking gear               | 23. Parking pawl        |                           |

# A/T CONTROL SYSTEM

UCS00410

## TCM Function

The function of the TCM is to:

- Receive input signals sent from various switches and sensors.
- Determine required line pressure, shifting point, lock-up operation, and engine brake operation.
- Send required output signals to the respective solenoids.

## CONTROL SYSTEM OUTLINE

The automatic transmission senses vehicle operating conditions through various sensors or signals. It always controls the optimum shift position and reduces shifting and lock-up shocks.

SENSORS (or SIGNALS)		TCM		ACTUATORS
PNP switch Accelerator pedal position sensor Closed throttle position signal Wide open throttle position signal Engine speed signal A/T fluid temperature sensor Revolution sensor Vehicle speed signal Stop lamp switch signal Turbine revolution sensor 1st position switch signal Overdrive control switch signal ATF pressure switch signal	⇒	Shift control Line pressure control Lock-up control Engine brake control Timing control Fail-safe control Self-diagnosis CONSULT-II communication line Duet-EA control CAN system	⇒	Input clutch solenoid valve Direct clutch solenoid valve Front brake solenoid valve High and low reverse clutch solenoid valve Low coast brake solenoid valve Torque converter clutch solenoid valve Line pressure solenoid valve O/D OFF indicator lamp Starter relay Back-up lamp relay

## CONTROL SYSTEM DIAGRAM

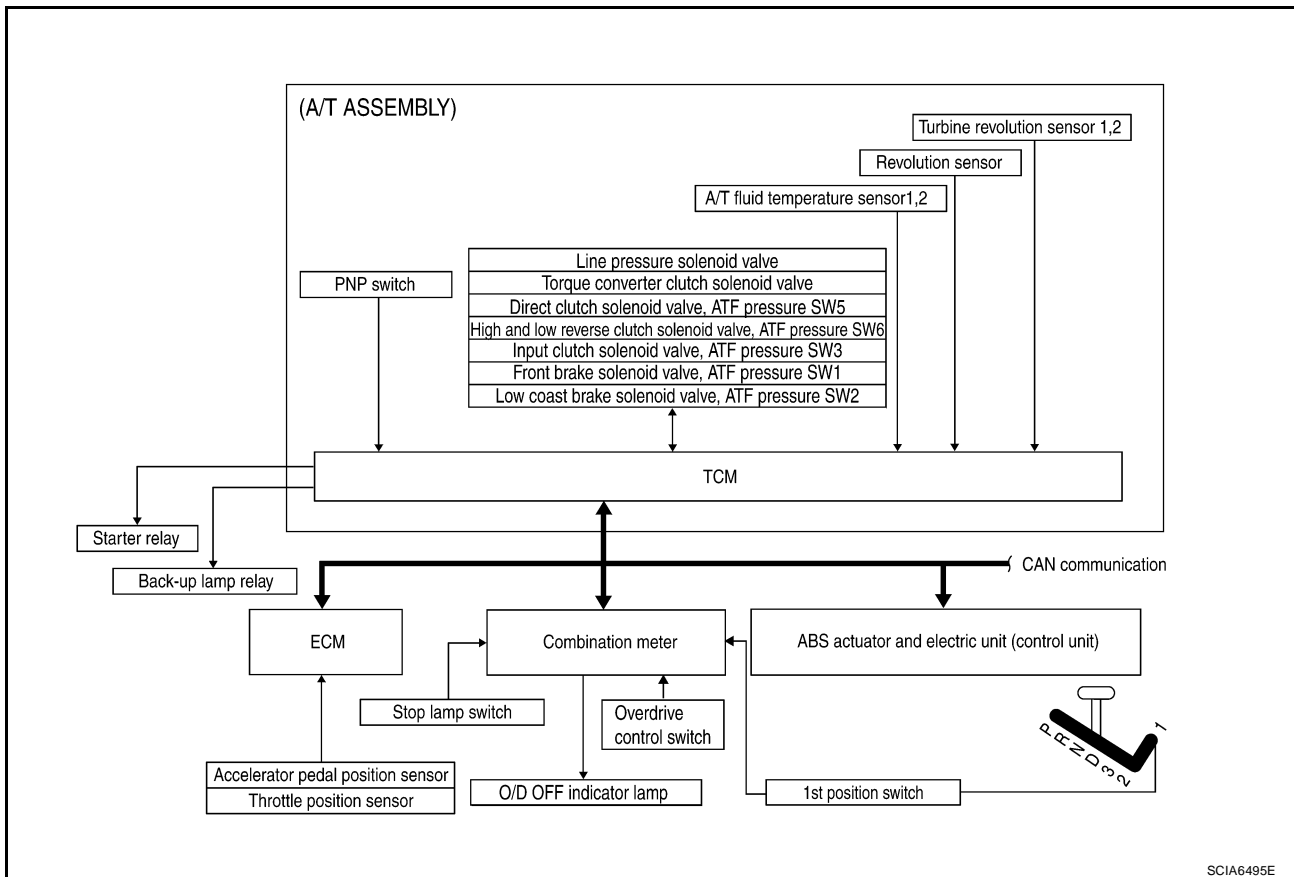

SCIA6495E

# A/T CONTROL SYSTEM

UCS0041P

## CAN Communication SYSTEM DESCRIPTION

CAN (Controller Area Network) is a serial communication line for real time application. It is an on-vehicle multiplex communication line with high data communication speed and excellent error detection ability. Many electronic control units are equipped onto a vehicle, and each control unit shares information and links with other control units during operation (not independent). In CAN communication, control units are connected with 2 communication lines (CAN H line, CAN L line) allowing a high rate of information transmission with less wiring. Each control unit transmits/receives data but selectively reads required data only. For details, refer to [LAN-48, "CAN System Specification Chart"](#).

## Input/Output Signal of TCM

ECS001Q9

Control item		Line pressure control	Vehicle speed control	Shift control	Lock-up control	Engine brake control	Fail-safe function (*3)	Self-diagnostics function	
Input	Accelerator pedal position signal (*5)	X	X	X	X	X	X	X	
	Vehicle speed sensor A/T (revolution sensor)	X	X	X	X	X	X	X	
	Vehicle speed sensor MTR(*1) (*5)						X		
	Closed throttle position signal(*5)		X(*2)	X	X		X	X(*4)	
	Wide open throttle position signal(*5)						X	X(*4)	
	Turbine revolution sensor 1		X		X	X	X	X	
	Turbine revolution sensor 2 (for 4th speed only)		X		X	X	X	X	
	Engine speed signals(*5)	X	X	X	X	X	X	X	
	Stop lamp switch signal(*5)		X	X	X			X(*4)	
	A/T fluid temperature sensors 1, 2	X	X	X	X		X	X	
	ASCD	Operation signal(*4)		X	X	X			
		Overdrive cancel signal(*5)		X					
Output	Direct clutch solenoid (ATF pressure switch 5)		X	X			X	X	
	Input clutch solenoid (ATF pressure switch 3)		X	X			X	X	
	High and low reverse clutch solenoid (ATF pressure switch 6)		X	X			X	X	
	Front brake solenoid (ATF pressure switch 1)		X	X			X	X	
	Low coast brake solenoid (ATF pressure switch 2)		X	X		X	X	X	
	Line pressure solenoid	X	X	X	X	X	X	X	
	TCC solenoid				X		X	X	
	Self-diagnosis table(*6)							X	
Starter relay						X	X		

\*1: Spare for vehicle speed sensor-A/T (revolution sensor)

\*2: Spare for accelerator pedal position signal

\*3: If these input and output signals are different, the TCM triggers the fail-safe function.

\*4: Used as a condition for starting self-diagnosis; if self-diagnosis are not started, it is judged that there is some kind of error

\*5: Input by CAN communications

\*6: Output by CAN communications



# A/T CONTROL SYSTEM

UCS0041R

## Line Pressure Control

- When an input torque signal equivalent to the engine drive force is sent from the ECM to the TCM, the TCM controls the line pressure solenoid.
- This line pressure solenoid controls the pressure regulator valve as the signal pressure and adjusts the pressure of the operating oil discharged from the oil pump to the line pressure most appropriate to the driving state.

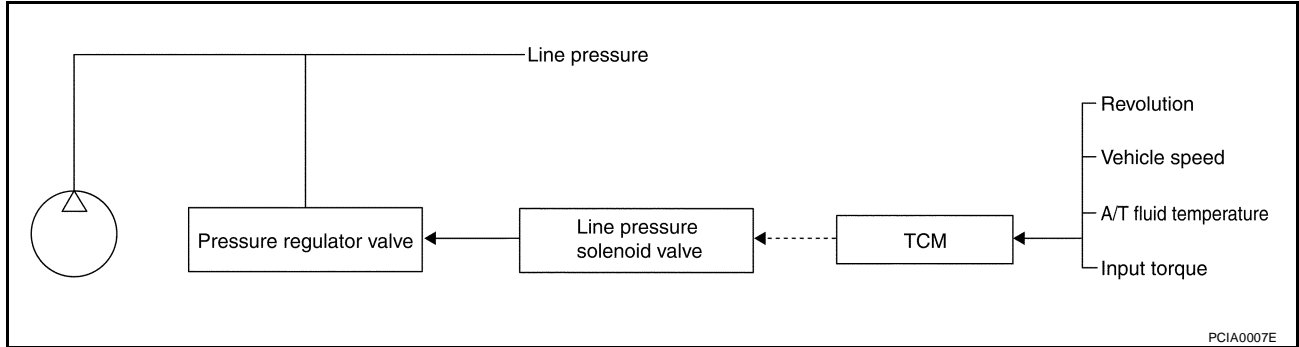

## LINE PRESSURE CONTROL IS BASED ON THE TCM LINE PRESSURE CHARACTERISTIC PATTERN

- The TCM has stored in memory a number of patterns for the optimum line pressure characteristic for the driving state.
- In order to obtain the most appropriate line pressure characteristic to meet the current driving state, the TCM controls the line pressure solenoid current value and thus controls the line pressure.

### Normal Control

Each clutch is adjusted to the necessary pressure to match the engine drive force.

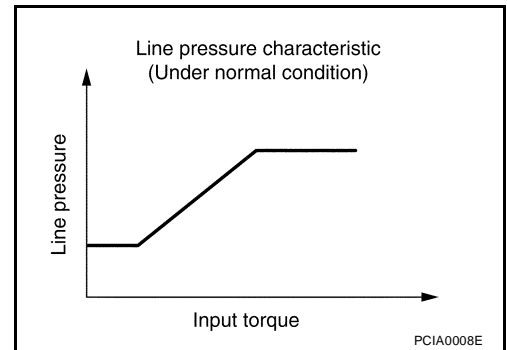

### Back-up Control (Engine Brake)

When the select operation is performed during driving and the transmission is shifted down, the line pressure is set according to the vehicle speed.

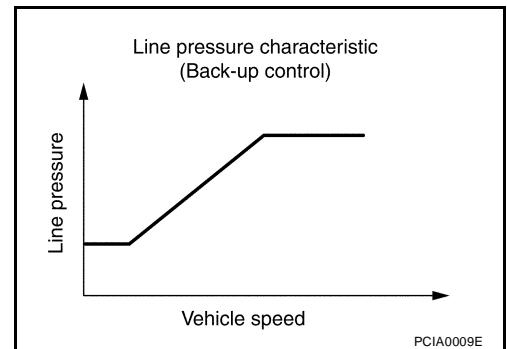

# A/T CONTROL SYSTEM

## During Shift Change

The necessary and adequate line pressure for shift change is set. For this reason, line pressure pattern setting corresponds to input torque and gearshift selection. Also, line pressure characteristic is set according to engine speed, during engine brake operation.

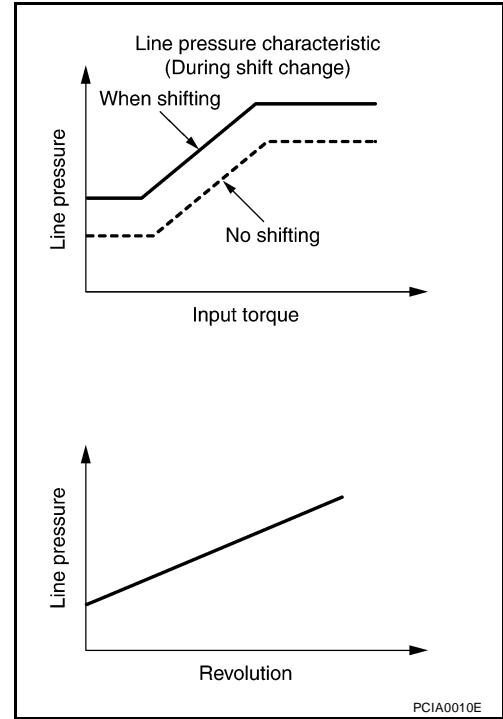

## At Low Fluid Temperature

When the A/T fluid temperature drops below the prescribed temperature, in order to speed up the action of each friction element, the line pressure is set higher than the normal line pressure characteristic.

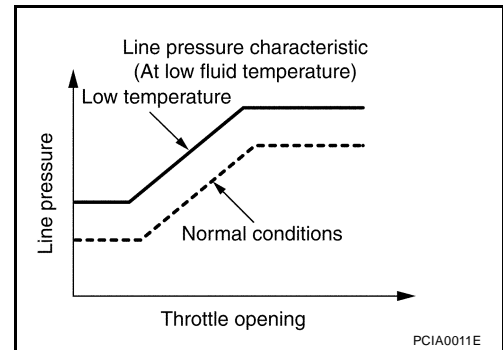

## Shift Control

UCS0041S

The clutch pressure control solenoid is controlled by the signals from the switches and sensors. Thus, the clutch pressure is adjusted to be appropriate to the engine load state and vehicle driving state. It becomes possible to finely control the clutch hydraulic pressure with high precision and a smoother shift change characteristic is attained.

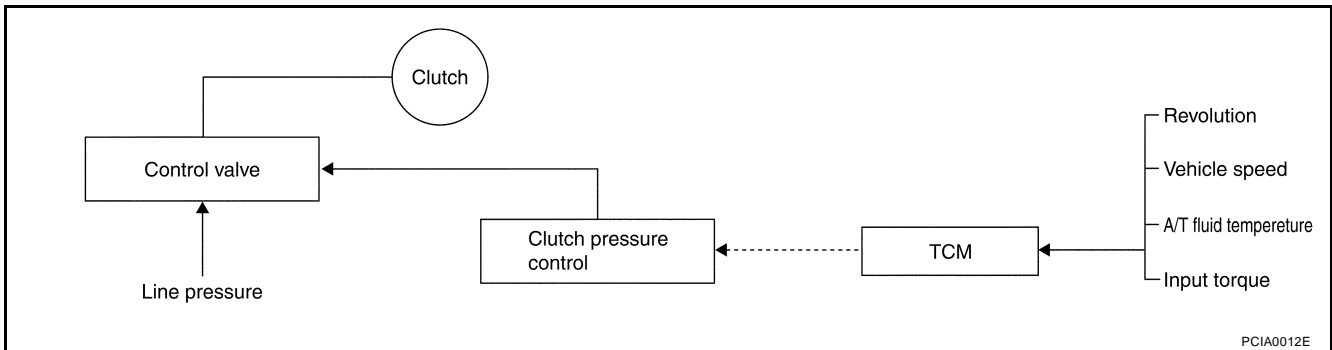

## SHIFT CHANGE

The clutch is controlled with the optimum timing and oil pressure by the engine speed, engine torque information, etc.

# A/T CONTROL SYSTEM

## Shift Change System Diagram

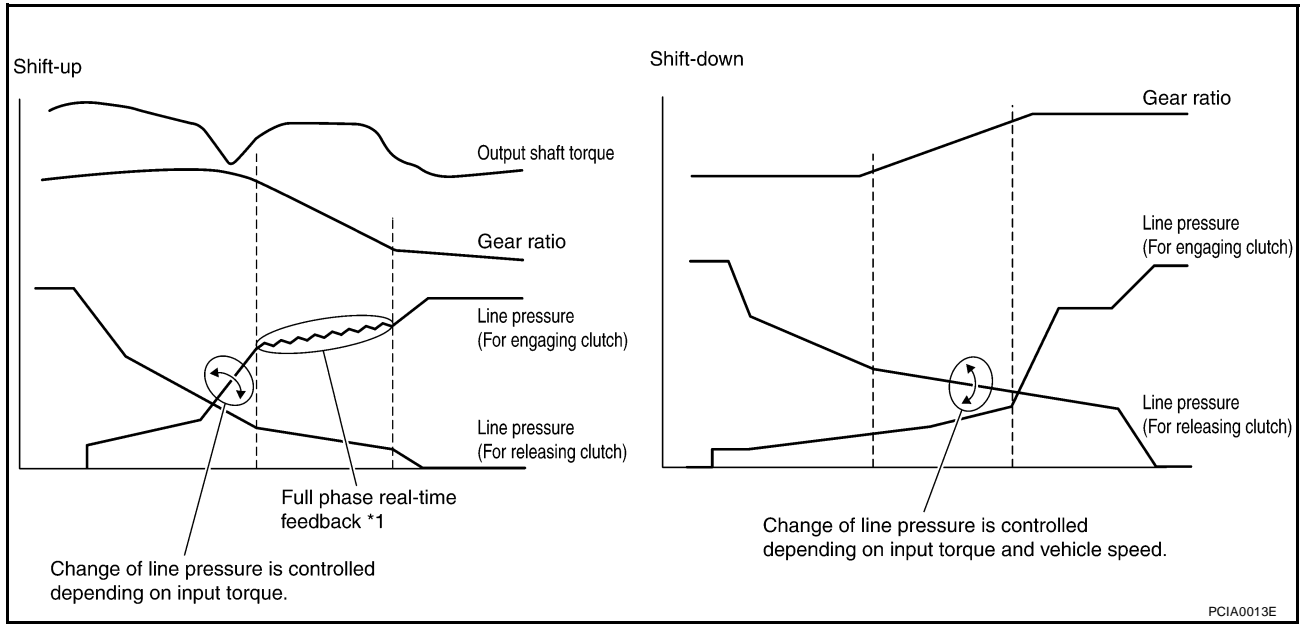

\*1: Full phase real-time feedback control monitors movement of gear ratio at gear change, and controls oil pressure at real-time to achieve the best gear ratio.

## Lock-up Control

UCS0041T

The torque converter clutch piston in the torque converter is engaged to eliminate torque converter slip to increase power transmission efficiency.

The torque converter clutch control valve operation is controlled by the torque converter clutch solenoid valve, which is controlled by a signal from TCM, and the torque converter clutch control valve engages or releases the torque converter clutch piston.

### Lock-up Operation Condition Table

Select lever	D position		3 position	2 position
Gear position	5	4	3	2
Lock-up	×	—	—	—
Slip lock-up	×	×	—	—

## TORQUE CONVERTER CLUTCH CONTROL VALVE CONTROL

### Lock-up Control System Diagram

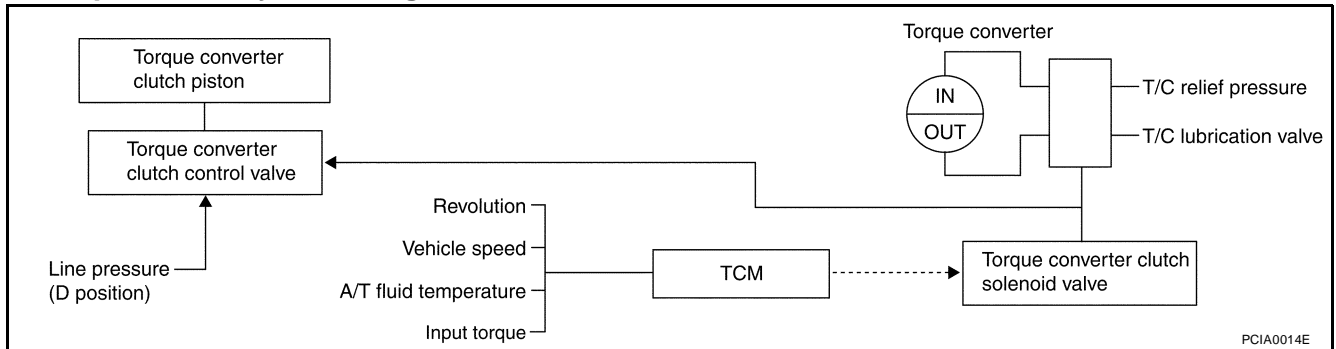

### Lock-up Released

- In the lock-up released state, the torque converter clutch control valve is set into the unlocked state by the torque converter clutch solenoid and the lock-up apply pressure is drained. In this way, the torque converter clutch piston is not coupled.

# A/T CONTROL SYSTEM

## Lock-up Applied

- In the lock-up applied state, the torque converter clutch control valve is set into the locked state by the torque converter clutch solenoid and lock-up apply pressure is generated. In this way, the torque converter clutch piston is pressed and coupled.

## SMOOTH LOCK-UP CONTROL

When shifting from the lock-up released state to the lock-up applied state, the current output to the torque converter clutch solenoid is controlled with the TCM. In this way, when shifting to the lock-up applied state, the torque converter clutch is temporarily set to the half-clutched state to reduce the shock.

## Half-clutched State

- The current output from the TCM to the torque converter clutch solenoid is varied to gradually increase the torque converter clutch solenoid pressure. In this way, the lock-up apply pressure gradually rises and while the torque converter clutch piston is put into half-clutched status, the torque converter clutch piston operating pressure is increased and the coupling is completed smoothly.

## Slip Lock-up Control

- In the slip region, the torque converter clutch solenoid current is controlled with the TCM to put it into the half-clutched state. This absorbs the engine torque fluctuation and lock-up operates from low speed. This raises the fuel efficiency for 4th and 5th gears at both low speed and when the accelerator has a low degree of opening.

## Engine Brake Control

UCS0041U

- The forward one-way clutch transmits the drive force from the engine to the rear wheels. But the reverse drive from the rear wheels is not transmitted to the engine because the one-way clutch is idling. Therefore, the low coast brake solenoid is operated to prevent the forward one-way clutch from idling and the engine brake is operated in the same manner as conventionally.

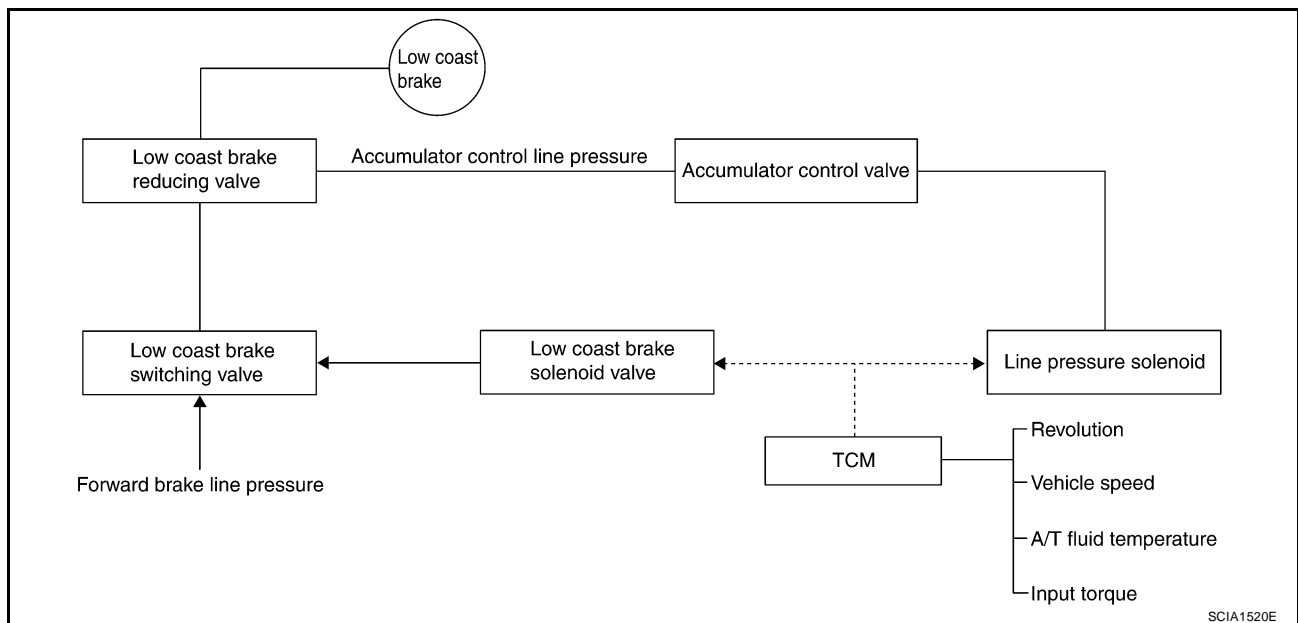

- The operation of the low coast brake solenoid switches the low coast brake switching valve and controls the coupling and releasing of the low coast brake. The low coast brake reducing valve controls the low coast brake coupling force.

# A/T CONTROL SYSTEM

## Control Valve FUNCTION OF CONTROL VALVE

UCS0041V

Name	Function
Torque converter regulator valve	In order to prevent the pressure supplied to the torque converter from being excessive, the line pressure is adjusted to the optimum pressure (torque converter operating pressure).
Pressure regulator valve Pressure regulator plug Pressure regulator sleeve	Adjusts the oil discharged from the oil pump to the optimum pressure (line pressure) for the driving state.
Front brake control valve	When the front brake is coupled, adjusts the line pressure to the optimum pressure (front brake pressure) and supplies it to the front brake. (In 1st, 2nd, 3rd, and 5th gears, adjusts the clutch pressure.)
Accumulator control valve	Adjusts the pressure (accumulator control pressure) acting on the accumulator piston and low coast reducing valve to the pressure appropriate to the driving state.
Pilot valve A	Adjusts the line pressure and produces the constant pressure (pilot pressure) required for line pressure control, shift change control, and lock-up control.
Pilot valve B	Adjusts the line pressure and produces the constant pressure (pilot pressure) required for shift change control.
Low coast brake switching valve	During engine braking, supplies the line pressure to the low coast brake reducing valve.
Low coast brake reducing valve	When the low coast brake is coupled, adjusts the line pressure to the optimum pressure (low coast brake pressure) and supplies it to the low coast brake.
N-R accumulator	Produces the stabilizing pressure for when N-R is selected.
Direct clutch piston switching valve	Operates in 4th gear and switches the direct clutch coupling capacity.
High and low reverse clutch control valve	When the high and low reverse clutch is coupled, adjusts the line pressure to the optimum pressure (high and low reverse clutch pressure) and supplies it to the high and low reverse clutch. (In 1st, 3rd, 4th and 5th gears, adjusts the clutch pressure.)
Input clutch control valve	When the input clutch is coupled, adjusts the line pressure to the optimum pressure (input clutch pressure) and supplies it to the input clutch. (In 4th and 5th gears, adjusts the clutch pressure.)
Direct clutch control valve	When the direct clutch is coupled, adjusts the line pressure to the optimum pressure (direct clutch pressure) and supplies it to the direct clutch. (In 2nd, 3rd, and 4th gears, adjusts the clutch pressure.)
TCC control valve TCC control plug TCC control sleeve	Switches the lock-up to operating or released. Also, by performing the lock-up operation transiently, lock-up smoothly.
Torque converter lubrication valve	Operates during lock-up to switch the torque converter, cooling, and lubrication system oil path.
Cool bypass valve	Allows excess oil to bypass cooler circuit without being fed into it.
Line pressure relief valve	Discharges excess oil from line pressure circuit.
N-D accumulator	Produces the stabilizing pressure for when N-D is selected.
Manual valve	Sends line pressure to each circuit according to the select position. The circuits to which the line pressure is not sent drain.

## FUNCTION OF PRESSURE SWITCH

Name	Function
Pressure switch 1 (FR/B)	Detects any malfunction in the front brake hydraulic pressure. When it detects any malfunction, it puts the system into fail-safe mode.
Pressure switch 2 (LC/B)	Detects any malfunction in the low coast brake hydraulic pressure. When it detects any malfunction, it puts the system into fail-safe mode.
Pressure switch 3 (I/C)	Detects any malfunction in the input clutch hydraulic pressure. When it detects any malfunction, it puts the system into fail-safe mode.

## A/T CONTROL SYSTEM

Name	Function
Pressure switch 5 (D/C)	Detects any malfunction in the direct clutch hydraulic pressure. When it detects any malfunction, it puts the system into fail-safe mode.
Pressure switch 6 (HLR/C)	Detects any malfunction in the high and low reverse clutch hydraulic pressure. When it detects any malfunction, it puts the system into fail-safe mode.

## ON BOARD DIAGNOSTIC (OBD) SYSTEM

PF0:00028

### Introduction

UCS0041W

The A/T system has two self-diagnostic systems.

The first is the emission-related on board diagnostic system (OBD-II) performed by the TCM in combination with the ECM. The malfunction is indicated by the MIL (malfunction indicator lamp) and is stored as a DTC in the ECM memory but not the TCM memory.

The second is the TCM original self-diagnosis indicated by the A/T CHECK indicator lamp. The malfunction is stored in the TCM memory. The detected items are overlapped with OBD-II self-diagnostic items. For detail, refer to [AT-89, "SELF-DIAGNOSTIC RESULT MODE"](#).

### OBD-II Function for A/T System

UCS0041X

The ECM provides emission-related on board diagnostic (OBD-II) functions for the A/T system. One function is to receive a signal from the TCM used with OBD-related parts of the A/T system. The signal is sent to the ECM when a malfunction occurs in the corresponding OBD-related part. The other function is to indicate a diagnostic result by means of the MIL (malfunction indicator lamp) on the instrument panel. Sensors, switches and solenoid valves are used as sensing elements.

The MIL automatically illuminates in One or Two Trip Detection Logic when a malfunction is sensed in relation to A/T system parts.

### One or Two Trip Detection Logic of OBD-II

UCS0041Y

#### ONE TRIP DETECTION LOGIC

If a malfunction is sensed during the first test drive, the MIL will illuminate and the malfunction will be stored in the ECM memory as a DTC. The TCM is not provided with such a memory function.

#### TWO TRIP DETECTION LOGIC

When a malfunction is sensed during the first test drive, it is stored in the ECM memory as a 1st trip DTC (diagnostic trouble code) or 1st trip freeze frame data. At this point, the MIL will not illuminate. — 1st Trip

If the same malfunction as that experienced during the first test drive is sensed during the second test drive, the MIL will illuminate. — 2nd Trip

The "Trip" in the "One or Two Trip Detection Logic" means a driving mode in which self-diagnosis is performed during vehicle operation.

### OBD-II Diagnostic Trouble Code (DTC)

UCS0041Z

#### HOW TO READ DTC AND 1ST TRIP DTC

DTC and 1st trip DTC can be read by the following methods.

( with **CONSULT-II** or ( **GST**) CONSULT-II or GST (Generic Scan Tool) Examples: P0705, P0720 etc.

These DTC are prescribed by SAE J2012.

(CONSULT-II also displays the malfunctioning component or system.)

- **1st trip DTC No. is the same as DTC No.**
- **Output of the diagnostic trouble code indicates that the indicated circuit has a malfunction. However, in case of the Mode II and GST, they do not indicate whether the malfunction is still occurring or occurred in the past and returned to normal.**  
**CONSULT-II can identify them as shown below, therefore, CONSULT-II (if available) is recommended.**

A sample of CONSULT-II display for DTC and 1st trip DTC is shown on the next page. DTC or 1st trip DTC of a malfunction is displayed in SELF-DIAGNOSTIC RESULTS mode for "ENGINE" with CONSULT-II. Time data indicates how many times the vehicle was driven after the last detection of a DTC.

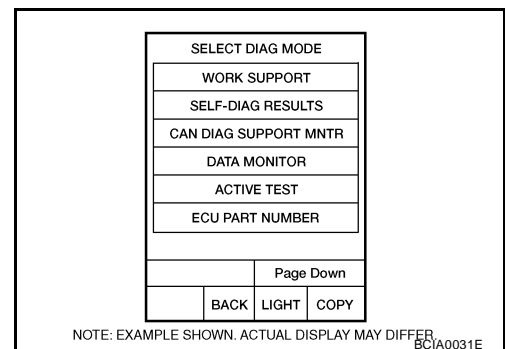

# ON BOARD DIAGNOSTIC (OBD) SYSTEM

If the DTC is being detected currently, the time data will be "0".

SELF-DIAG RESULTS	
DTC RESULTS	TIME
PNP SW/CIRC [P0705]	0

SAT015K

If a 1st trip DTC is stored in the ECM, the time data will be "1t".

SELF-DIAG RESULTS	
DTC RESULTS	TIME
PNP SW/CIRC [P0705]	1 t

SAT016K

## Freeze Frame Data and 1st Trip Freeze Frame Data

The ECM has a memory function, which stores the driving condition such as fuel system status, calculated load value, engine coolant temperature, short term fuel trim, long term fuel trim, engine speed and vehicle speed at the moment the ECM detects a malfunction.

Data which are stored in the ECM memory, along with the 1st trip DTC, are called 1st trip freeze frame data, and the data, stored together with the DTC data, are called freeze frame data and displayed on CONSULT-II or GST. The 1st trip freeze frame data can only be displayed on the CONSULT-II screen, not on the GST. For detail, refer to [AT-39, "ON BOARD DIAGNOSTIC \(OBD\) SYSTEM"](#).

Only one set of freeze frame data (either 1st trip freeze frame data or freeze frame data) can be stored in the ECM. 1st trip freeze frame data is stored in the ECM memory along with the 1st trip DTC. There is no priority for 1st trip freeze frame data and it is updated each time a different 1st trip DTC is detected. However, once freeze frame data (2nd trip detection/MIL on) is stored in the ECM memory, 1st trip freeze frame data is no longer stored. Remember, only one set of freeze frame data can be stored in the ECM. The ECM has the following priorities to update the data.

Priority	Items
1	Freeze frame data Misfire — DTC: P0300 - P0306 Fuel Injection System Function — DTC: P0171, P0172, P0174, P0175
2	Except the above items (Includes A/T related items)
3	1st trip freeze frame data

Both 1st trip freeze frame data and freeze frame data (along with the DTC) are cleared when the ECM memory is erased.

## HOW TO ERASE DTC

The diagnostic trouble code can be erased by CONSULT-II, GST or ECM DIAGNOSTIC TEST MODE as described following.

- If the battery cable is disconnected, the diagnostic trouble code will be lost within 24 hours.
- When you erase the DTC, using CONSULT-II or GST is easier and quicker than switching the mode selector on the ECM.

The following emission-related diagnostic information is cleared from the ECM memory when erasing DTC related to OBD-II. For details, refer to [EC-54, "EMISSION-RELATED DIAGNOSTIC INFORMATION ITEMS"](#) (QR) or [EC-658, "EMISSION-RELATED DIAGNOSTIC INFORMATION ITEMS"](#) . (VQ)

- Diagnostic trouble codes (DTC)
- 1st trip diagnostic trouble codes (1st trip DTC)



# ON BOARD DIAGNOSTIC (OBD) SYSTEM

- Freeze frame data
- 1st trip freeze frame data
- System readiness test (SRT) codes
- Test values

## Ⓟ HOW TO ERASE DTC (WITH CONSULT-II)

- If a DTC is displayed for both ECM and TCM, it is necessary to be erased for both ECM and TCM.
1. If the ignition switch stays "ON" after repair work, be sure to turn ignition switch "OFF" once. Wait at least 10 seconds and then turn it "ON" (engine stopped) again.
  2. Turn CONSULT-II "ON" and touch "A/T".
  3. Touch "SELF-DIAG RESULTS".
  4. Touch "ERASE". (The DTC in the TCM will be erased.) Then touch "BACK" twice.
  5. Touch "ENGINE".
  6. Touch "SELF-DIAG RESULTS".
  7. Touch "ERASE". (The DTC in the ECM will be erased.)

### How to erase DTC (With CONSULT-II)

1. If the ignition switch stays "ON" after repair work, be sure to turn ignition switch "OFF" once. Wait at least 10 seconds and then turn it "ON" (engine stopped) again.

SELECT SYSTEM
A/T
ENGINE

2. Turn CONSULT-II "ON", and touch "A/T".

SELECT DIAG MODE
SELF-DIAG RESULTS
DATA MONITOR
CAN DIAG SUPPORT MNTR
FUNCTION TEST
DTC WORK SUPPORT
ECU PART NUMBER

3. Touch "SELF-DIAG RESULTS".

SELF-DIAG RESULTS
DTC RESULTS
TCC SOLENOID/CIRC [P0740]

4. Touch "ERASE". (The DTC in the TCM will be erased.)

Touch "BACK".

Touch "BACK".

SELECT SYSTEM
A/T
ENGINE

5. Touch "ENGINE".

SELECT DIAG MODE
WORK SUPPORT
SELF-DIAG RESULTS
DATA MONITOR
DATA MONITOR(SPEC)
CAN DIAG SUPPORT MNTR
ACTIVE TEST

6. Touch "SELF-DIAG RESULTS".

SELF-DIAG RESULTS	
DTC RESULTS	TIME
TCC SOLENOID/CIRC [P0740]	0

7. Touch "ERASE". (The DTC in the TCM will be erased.)

SCIA5671E

## Ⓟ HOW TO ERASE DTC (WITH GST)

1. If the ignition switch stays "ON" after repair work, be sure to turn ignition switch "OFF" once. Wait at least 10 seconds and then turn it "ON" (engine stopped) again.
2. Select Mode 4 with the Generic Scan Tool (GST). For details refer to [EC-129, "Generic Scan Tool \(GST\) Function"](#) (QR) or [EC-738, "Generic Scan Tool \(GST\) Function"](#) (VQ).

# ON BOARD DIAGNOSTIC (OBD) SYSTEM



## HOW TO ERASE DTC (NO TOOLS)

1. Disconnect battery for 24 hours.
2. Reconnect battery.

## Malfunction Indicator Lamp (MIL)

UCS00420

### DESCRIPTION

The MIL is located on the instrument panel.

1. The MIL will light up when the ignition switch is turned "ON" without the engine running. This is a bulb check.
  - If the MIL does not light up, refer to [DI-31, "WARNING LAMPS"](#).
2. When the engine is started, the MIL should go off. If the MIL remains on, the on board diagnostic system has detected an engine system malfunction.

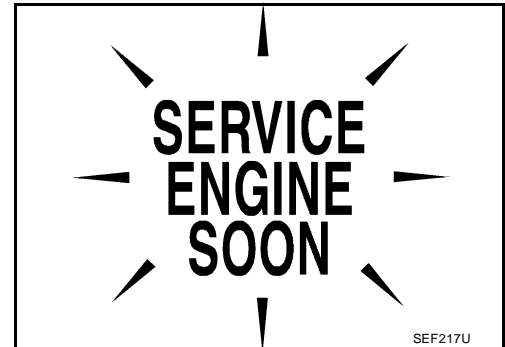

# TROUBLE DIAGNOSIS

## TROUBLE DIAGNOSIS

PFP:00004

### DTC Inspection Priority Chart

UCS00421

If some DTCs are displayed at the same time, perform inspections one by one based on the following priority chart.

#### NOTE:

If DTC U1000 is displayed with other DTCs, first perform the trouble diagnosis for DTC U1000. Refer to [AT-98](#).

Priority	Detected items (DTC)
1	U1000 CAN communication line
2	Except above

### Fail-Safe

UCS00422

The TCM has an electrical fail-safe mode. This mode makes it possible to operate even if there is an error in a main electronic control input/output signal circuit. In fail-safe mode the transmission is fixed in 2nd, 4th or 5th (depending on the breakdown position), so the customer should feel "slipping" or "poor acceleration".

Even when the electronic circuits are normal, under special conditions (for example, when slamming on the brake with the wheels spinning drastically and stopping the tire rotation), the transmission can go into fail-safe mode. If this happens, switch "OFF" the ignition switch for 10 seconds, then switch it "ON" again to return to the normal shift pattern. Therefore, the customer's vehicle has returned to normal, so handle according to the "diagnostics flow" (Refer to [AT-46. "WORK FLOW"](#) ).

### FAIL-SAFE FUNCTION

If any malfunction occurs in a sensor or solenoid, this function controls the A/T to mark driving possible.

#### Vehicle Speed Sensor

- Signals are input from two systems - from vehicle speed sensor A/T (revolution sensor) installed on the transmission and from combination meter so normal driving is possible even if there is a malfunction in one of the systems. And if vehicle speed sensor A/T (revolution sensor) has unusual cases, 5th gear is prohibited.

#### Accelerator Pedal Position Sensor

- If there is a malfunction in one of the systems, the accelerator opening angle is controlled by ECM according to a pre-determined accelerator angle to make driving possible. And if there are malfunctions in tow systems, the engine speed is fixed by ECM to a pre-determined engine speed to make driving possible.

#### Throttle Position Sensor

- If there is a malfunction in one of the systems, the accelerator opening angle is controlled by ECM according to a pre-determined accelerator angle to make driving possible. And if there are malfunctions in tow systems, the accelerator opening angle is controlled by the idle signal sent from the ECM which is based on input indicating either idle condition or off-idle condition (pre-determined accelerator opening) in order to make driving possible.

#### PNP Switch

- In the unlikely event that a malfunction signal enters the TCM, the position indicator is switched "OFF", the starter relay is switched "OFF" (starter starting is disabled), the back-up lamp relay switched "OFF" (back-up lamp is OFF) and the position is fixed to the "D" range to make driving possible.

#### Starter Relay

- The starter relay is switched "OFF". (Starter starting is disabled.)

# TROUBLE DIAGNOSIS

## A/T Interlock

- If there is an A/T interlock judgment malfunction, the transmission is fixed in 2nd gear to make driving possible.

### NOTE:

**When the vehicle is driven fixed in 2nd gear, a turbine revolution sensor malfunction is displayed, but this is not a turbine revolution sensor malfunction.**

- When the coupling pattern below is detected, the fail-safe action corresponding to the pattern is performed.

### A/T INTERLOCK COUPLING PATTERN TABLE

●: NG X: OK

Gear position		ATF pressure switch output					Fail-safe function	Clutch pressure output pattern after fail-safe function					
		SW3 (I/C)	SW6 (HLR/C)	SW5 (D/C)	SW1 (FR/B)	SW2 (LC/B)		I/C	HLR/C	D/C	FR/B	LC/B	L/U
A/T interlock coupling pattern	3rd	–	X	X	–	●	Held in 2nd gear	OFF	OFF	ON	OFF	OFF	OFF
	4th	–	X	X	–	●	Held in 2nd gear	OFF	OFF	ON	OFF	OFF	OFF
	5th	X	X	–	X	●	Held in 2nd gear	OFF	OFF	ON	OFF	OFF	OFF

## A/T 1st Engine Braking

- When there is an A/T first gear engine brake judgment malfunction, the low coast brake solenoid is switched “OFF” to avoid the engine brake operation.

## Line Pressure Solenoid

- The solenoid is switched “OFF” and the line pressure is set to the maximum hydraulic pressure to make driving possible.

## Torque Converter Clutch Solenoid

- The solenoid is switched “OFF” to release the lock-up.

## Low Coast Brake Solenoid

- When a (electrical or functional) malfunction occurs, in order to make driving possible, the engine brake is not applied in 1st and 2nd gear.

## Input Clutch Solenoid

- If a (electrical or functional) malfunction occurs with the solenoid either “ON” or “OFF”, the transmission is held in 4th gear to make driving possible.

## Direct Clutch Solenoid

- If a (electrical or functional) malfunction occurs with the solenoid either “ON” or “OFF”, the transmission is held in 4th gear to make driving possible.

## Front Brake Solenoid

- If a (electrical or functional) malfunction occurs with the solenoid “ON”, in order to make driving possible, the A/T is held in 5th gear; if the solenoid is OFF, 4th gear.

## High and Low Reverse Clutch Solenoid

- If a (electrical or functional) malfunction occurs with the solenoid either “ON” or “OFF”, the transmission is held in 4th gear to make driving possible.

## Turbine Revolution Sensor 1 or 2

- The control is the same as if there were no turbine revolution sensors, 5th gear is prohibited.

# TROUBLE DIAGNOSIS

## How To Perform Trouble Diagnosis For Quick and Accurate Repair INTRODUCTION

UCS00423

The TCM receives a signal from the vehicle speed sensor, accelerator pedal position sensor (throttle position sensor) or PNP switch and provides shift control or lock-up control via A/T solenoid valves.

The TCM also communicates with the ECM by means of a signal sent from sensing elements used with the OBD-related parts of the A/T system for malfunction-diagnostic purposes. The TCM is capable of diagnosing malfunctioning parts while the ECM can store malfunctions in its memory.

Input and output signals must always be correct and stable in the operation of the A/T system. The A/T system must be in good operating condition and be free of valve seizure, solenoid valve malfunction, etc.

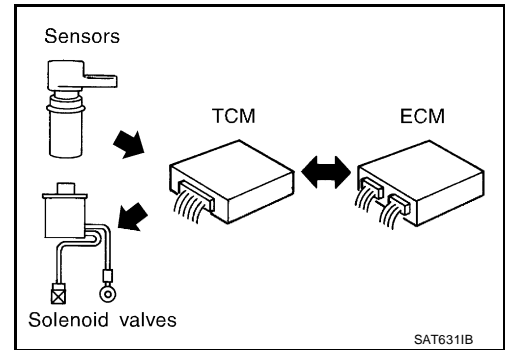

It is much more difficult to diagnose a error that occurs intermittently rather than continuously. Most intermittent errors are caused by poor electric connections or improper wiring. In this case, careful checking of suspected circuits may help prevent the replacement of good parts.

A visual check only may not find the cause of the errors. A road test with CONSULT-II (or GST) or a circuit tester connected should be performed. Follow the [AT-46, "WORK FLOW"](#).

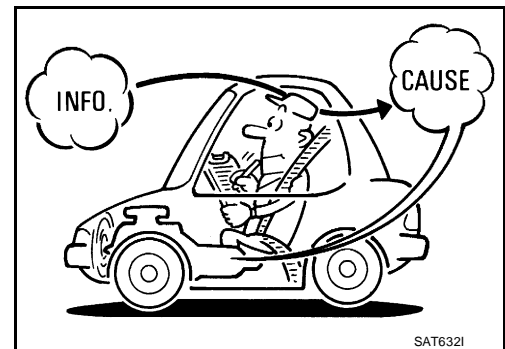

Before undertaking actual checks, take a few minutes to talk with a customer who approaches with a driveability complaint. The customer can supply good information about such errors, especially intermittent ones. Find out what symptoms are present and under what conditions they occur. A "Diagnostic Worksheet" as shown on the example (Refer to [AT-47](#)) should be used.

Start your diagnosis by looking for "conventional" errors first. This will help troubleshoot driveability errors on an electronically controlled engine vehicle.

Also check related Service bulletins.

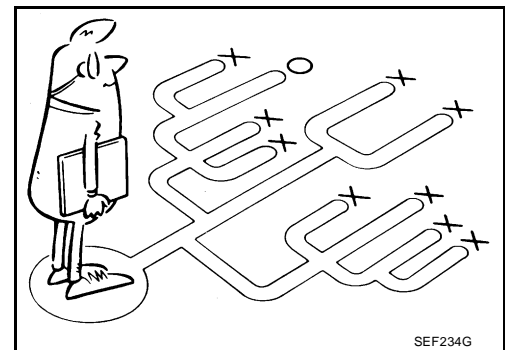

# TROUBLE DIAGNOSIS

## WORK FLOW

A good understanding of the malfunction conditions can make troubleshooting faster and more accurate. In general, each customer feels differently about a malfunction. It is important to fully understand the symptoms or conditions for a customer complaint.

Make good use of the two sheets provided, "Information From Customer" (Refer to [AT-47](#) ) and "Diagnostic Worksheet" (Refer to [AT-47](#) ), to perform the best troubleshooting possible.

## Work Flow Chart

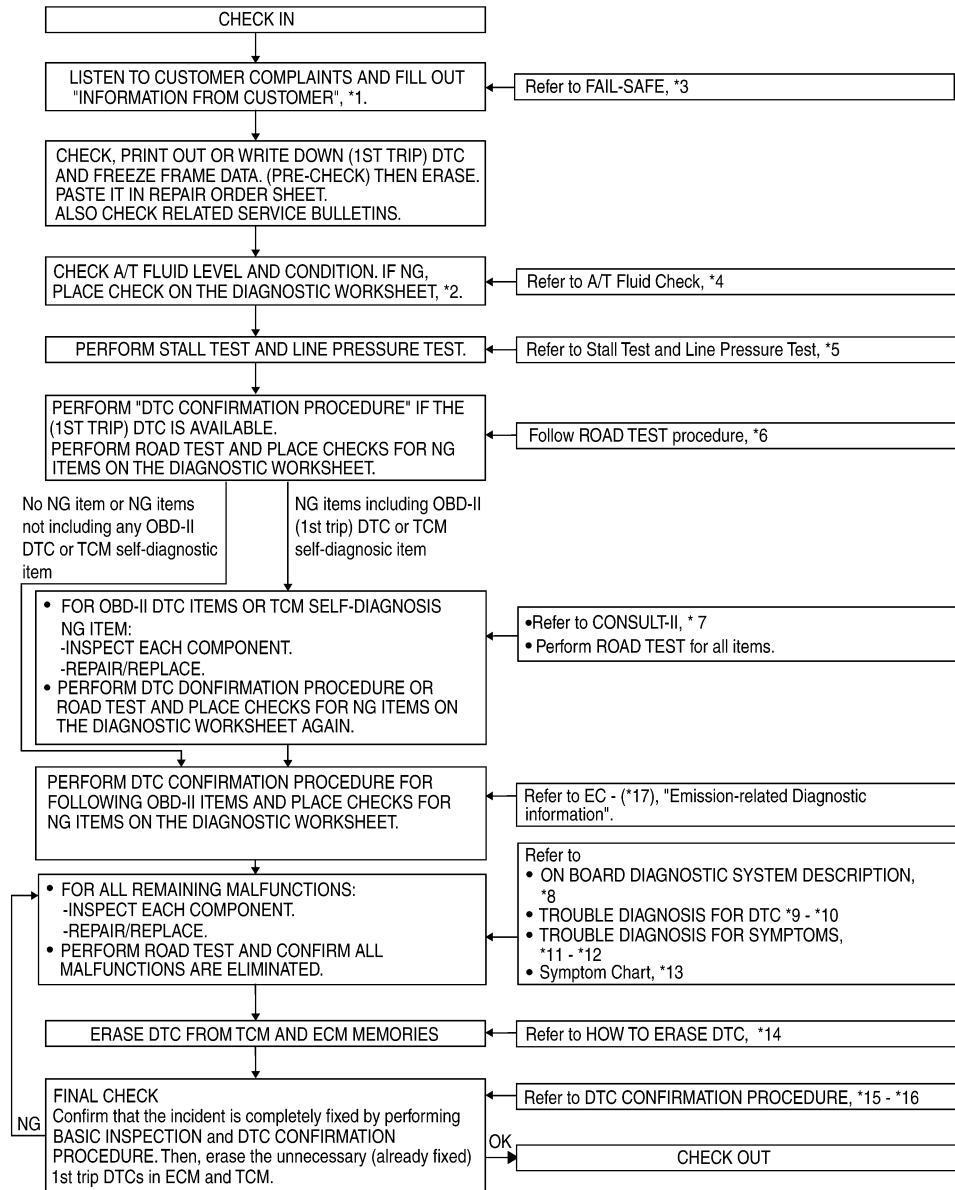

\*1. [AT-47](#)

\*4. [AT-52](#)

\*7. [AT-87](#)

\*10. [AT-166](#)

\*13. [AT-64](#)

\*16. [AT-166](#)

\*2. [AT-47](#)

\*5. [AT-52](#), [AT-53](#)

\*8. [AT-39](#)

\*11. [AT-178](#)

\*14. [AT-40](#)

\*17. [EC-54](#) (QR), [EC-658](#) (VQ)

\*3. [AT-43](#)

\*6. [AT-55](#)

\*9. [AT-98](#)

\*12. [AT-214](#)

\*15. [AT-98](#)

WCIA0517E



# TROUBLE DIAGNOSIS

	<input type="checkbox"/> Perform all road tests and enter checks in required inspection items.	<a href="#">AT-55</a>
4	4-1. Check before engine is started	<a href="#">AT-56</a>
	<input type="checkbox"/> <a href="#">AT-178, "O/D OFF Indicator Lamp Does Not Come On"</a> <input type="checkbox"/> Perform self-diagnostics Enter checks for detected items. <a href="#">AT-89</a>	
	<input type="checkbox"/> <a href="#">AT-98, "DTC U1000 CAN COMMUNICATION LINE"</a> <input type="checkbox"/> <a href="#">AT-101, "DTC P0615 START SIGNAL CIRCUIT"</a> <input type="checkbox"/> <a href="#">AT-105, "DTC P0700 TCM"</a> <input type="checkbox"/> <a href="#">AT-106, "DTC P0705 PARK/NEUTRAL POSITION SWITCH"</a> <input type="checkbox"/> <a href="#">AT-110, "DTC P0717 TURBINE REVOLUTION SENSOR"</a> <input type="checkbox"/> <a href="#">AT-112, "DTC P0720 VEHICLE SPEED SENSOR A/T (REVOLUTION SENSOR)"</a> <input type="checkbox"/> <a href="#">AT-117, "DTC P0725 ENGINE SPEED SIGNAL"</a> <input type="checkbox"/> <a href="#">AT-119, "DTC P0740 TORQUE CONVERTER CLUTCH SOLENOID VALVE"</a> <input type="checkbox"/> <a href="#">AT-121, "DTC P0744 A/T TCC S/V FUNCTION (LOCK-UP)"</a> <input type="checkbox"/> <a href="#">AT-123, "DTC P0745 LINE PRESSURE SOLENOID VALVE"</a> <input type="checkbox"/> <a href="#">AT-125, "DTC P1705 THROTTLE POSITION SENSOR"</a> <input type="checkbox"/> <a href="#">AT-128, "DTC P1710 A/T FLUID TEMPERATURE SENSOR CIRCUIT"</a> <input type="checkbox"/> <a href="#">AT-133, "DTC P1721 VEHICLE SPEED SENSOR MTR"</a> <input type="checkbox"/> <a href="#">AT-135, "DTC P1730 A/T INTERLOCK"</a> <input type="checkbox"/> <a href="#">AT-138, "DTC P1731 A/T 1ST ENGINE BRAKING"</a> <input type="checkbox"/> <a href="#">AT-140, "DTC P1752 INPUT CLUTCH SOLENOID VALVE"</a> <input type="checkbox"/> <a href="#">AT-142, "DTC P1754 INPUT CLUTCH SOLENOID VALVE FUNCTION"</a> <input type="checkbox"/> <a href="#">AT-144, "DTC P1757 FRONT BRAKE SOLENOID VALVE"</a> <input type="checkbox"/> <a href="#">AT-146, "DTC P1759 FRONT BRAKE SOLENOID VALVE FUNCTION"</a> <input type="checkbox"/> <a href="#">AT-148, "DTC P1762 DIRECT CLUTCH SOLENOID VALVE"</a> <input type="checkbox"/> <a href="#">AT-150, "DTC P1764 DIRECT CLUTCH SOLENOID VALVE FUNCTION"</a> <input type="checkbox"/> <a href="#">AT-152, "DTC P1767 HIGH AND LOW REVERSE CLUTCH SOLENOID VALVE"</a> <input type="checkbox"/> <a href="#">AT-154, "DTC P1769 HIGH AND LOW REVERSE CLUTCH SOLENOID VALVE FUNCTION"</a> <input type="checkbox"/> <a href="#">AT-156, "DTC P1772 LOW COAST BRAKE SOLENOID VALVE"</a> <input type="checkbox"/> <a href="#">AT-158, "DTC P1774 LOW COAST BRAKE SOLENOID VALVE FUNCTION"</a> <input type="checkbox"/> <a href="#">AT-160, "DTC P1841 ATF PRESSURE SWITCH 1"</a> <input type="checkbox"/> <a href="#">AT-162, "DTC P1843 ATF PRESSURE SWITCH 3"</a> <input type="checkbox"/> <a href="#">AT-164, "DTC P1845 ATF PRESSURE SWITCH 5"</a> <input type="checkbox"/> <a href="#">AT-166, "DTC P1846 ATF PRESSURE SWITCH 6"</a>	
4	4-2. Idle inspection	<a href="#">AT-56</a>
	<input type="checkbox"/> <a href="#">AT-179, "Engine Cannot Be Started In "P" or "N" Position"</a> <input type="checkbox"/> <a href="#">AT-180, "In "P" Position, Vehicle Moves When Pushed"</a> <input type="checkbox"/> <a href="#">AT-181, "In "N" Position, Vehicle Moves"</a> <input type="checkbox"/> <a href="#">AT-182, "Large Shock ("N" to "D" Position)"</a> <input type="checkbox"/> <a href="#">AT-184, "Vehicle Does Not Creep Backward In "R" Position"</a> <input type="checkbox"/> <a href="#">AT-187, "Vehicle Does Not Creep Forward In "D" Position"</a>	
4	4-3. Driving tests	<a href="#">AT-56</a>
	Part 1 <input type="checkbox"/> <a href="#">AT-189, "Vehicle Cannot Be Started From D1"</a> <input type="checkbox"/> <a href="#">AT-191, "A/T Does Not Shift: D1 → D2"</a> <input type="checkbox"/> <a href="#">AT-193, "A/T Does Not Shift: D2 → D3"</a> <input type="checkbox"/> <a href="#">AT-195, "A/T Does Not Shift: D3 → D4"</a> <input type="checkbox"/> <a href="#">AT-197, "A/T Does Not Shift: D4 → D5"</a> <input type="checkbox"/> <a href="#">AT-199, "A/T Does Not Perform Lock-up"</a> <input type="checkbox"/> <a href="#">AT-201, "A/T Does Not Hold Lock-up Condition"</a> <input type="checkbox"/> <a href="#">AT-203, "Lock-up Is Not Released"</a> <input type="checkbox"/> <a href="#">AT-204, "Engine Speed Does Not Return to Idle"</a>	



# TROUBLE DIAGNOSIS

4	4-3	Part 2 <input type="checkbox"/> <a href="#">AT-189, "Vehicle Cannot Be Started From D1"</a> <input type="checkbox"/> <a href="#">AT-191, "A/T Does Not Shift: D1 → D2"</a> <input type="checkbox"/> <a href="#">AT-193, "A/T Does Not Shift: D2 → D3"</a> <input type="checkbox"/> <a href="#">AT-195, "A/T Does Not Shift: D3 → D4"</a>	<a href="#">AT-59</a>	A
		Part 3 <input type="checkbox"/> <a href="#">AT-206, "A/T Does Not Shift: 5th gear → 4th gear"</a> <input type="checkbox"/> <a href="#">AT-208, "A/T Does Not Shift: 4th gear → 3rd gear"</a> <input type="checkbox"/> <a href="#">AT-210, "A/T Does Not Shift: 3rd gear → 2nd gear"</a> <input type="checkbox"/> <a href="#">AT-212, "A/T Does Not Shift: 2nd gear → 1st gear"</a> <input type="checkbox"/> <a href="#">AT-214, "Vehicle Does Not Decelerate By Engine Brake"</a> <input type="checkbox"/> Perform self-diagnostics Enter checks for detected items. <a href="#">AT-89</a>	<a href="#">AT-60</a>	B
		<input type="checkbox"/> <a href="#">AT-98, "DTC U1000 CAN COMMUNICATION LINE"</a> <input type="checkbox"/> <a href="#">AT-101, "DTC P0615 START SIGNAL CIRCUIT"</a> <input type="checkbox"/> <a href="#">AT-105, "DTC P0700 TCM"</a> <input type="checkbox"/> <a href="#">AT-106, "DTC P0705 PARK/NEUTRAL POSITION SWITCH"</a> <input type="checkbox"/> <a href="#">AT-110, "DTC P0717 TURBINE REVOLUTION SENSOR"</a> <input type="checkbox"/> <a href="#">AT-112, "DTC P0720 VEHICLE SPEED SENSOR A/T (REVOLUTION SENSOR)"</a> <input type="checkbox"/> <a href="#">AT-117, "DTC P0725 ENGINE SPEED SIGNAL"</a> <input type="checkbox"/> <a href="#">AT-119, "DTC P0740 TORQUE CONVERTER CLUTCH SOLENOID VALVE"</a> <input type="checkbox"/> <a href="#">AT-121, "DTC P0744 A/T TCC S/V FUNCTION (LOCK-UP)"</a> <input type="checkbox"/> <a href="#">AT-123, "DTC P0745 LINE PRESSURE SOLENOID VALVE"</a> <input type="checkbox"/> <a href="#">AT-125, "DTC P1705 THROTTLE POSITION SENSOR"</a> <input type="checkbox"/> <a href="#">AT-128, "DTC P1710 A/T FLUID TEMPERATURE SENSOR CIRCUIT"</a> <input type="checkbox"/> <a href="#">AT-133, "DTC P1721 VEHICLE SPEED SENSOR MTR"</a> <input type="checkbox"/> <a href="#">AT-135, "DTC P1730 A/T INTERLOCK"</a> <input type="checkbox"/> <a href="#">AT-138, "DTC P1731 A/T 1ST ENGINE BRAKING"</a> <input type="checkbox"/> <a href="#">AT-140, "DTC P1752 INPUT CLUTCH SOLENOID VALVE"</a> <input type="checkbox"/> <a href="#">AT-142, "DTC P1754 INPUT CLUTCH SOLENOID VALVE FUNCTION"</a> <input type="checkbox"/> <a href="#">AT-144, "DTC P1757 FRONT BRAKE SOLENOID VALVE"</a> <input type="checkbox"/> <a href="#">AT-146, "DTC P1759 FRONT BRAKE SOLENOID VALVE FUNCTION"</a> <input type="checkbox"/> <a href="#">AT-148, "DTC P1762 DIRECT CLUTCH SOLENOID VALVE"</a> <input type="checkbox"/> <a href="#">AT-150, "DTC P1764 DIRECT CLUTCH SOLENOID VALVE FUNCTION"</a> <input type="checkbox"/> <a href="#">AT-152, "DTC P1767 HIGH AND LOW REVERSE CLUTCH SOLENOID VALVE"</a> <input type="checkbox"/> <a href="#">AT-154, "DTC P1769 HIGH AND LOW REVERSE CLUTCH SOLENOID VALVE FUNCTION"</a> <input type="checkbox"/> <a href="#">AT-156, "DTC P1772 LOW COAST BRAKE SOLENOID VALVE"</a> <input type="checkbox"/> <a href="#">AT-158, "DTC P1774 LOW COAST BRAKE SOLENOID VALVE FUNCTION"</a> <input type="checkbox"/> <a href="#">AT-160, "DTC P1841 ATF PRESSURE SWITCH 1"</a> <input type="checkbox"/> <a href="#">AT-162, "DTC P1843 ATF PRESSURE SWITCH 3"</a> <input type="checkbox"/> <a href="#">AT-164, "DTC P1845 ATF PRESSURE SWITCH 5"</a> <input type="checkbox"/> <a href="#">AT-166, "DTC P1846 ATF PRESSURE SWITCH 6"</a>		AT
		<input type="checkbox"/> Inspect each system for items found to be NG in the self-diagnostics and repair or replace the malfunction parts.		D
5	<input type="checkbox"/> Perform all road tests and enter the checks again for the required items.	<a href="#">AT-55</a>	E	
6	<input type="checkbox"/> For any remaining NG items, perform the "diagnostics procedure" and repair or replace the malfunction parts. See the chart for diagnostics by symptoms. (This chart also contains other symptoms and inspection procedures.)	<a href="#">AT-64</a>	F	
7	<input type="checkbox"/> Erase the results of the self-diagnostics from the TCM.	<a href="#">AT-40</a>	G	
8			H	
			I	
			J	
			K	
			L	
			M	

# TROUBLE DIAGNOSIS

## A/T Electrical Parts Location

UCS00424

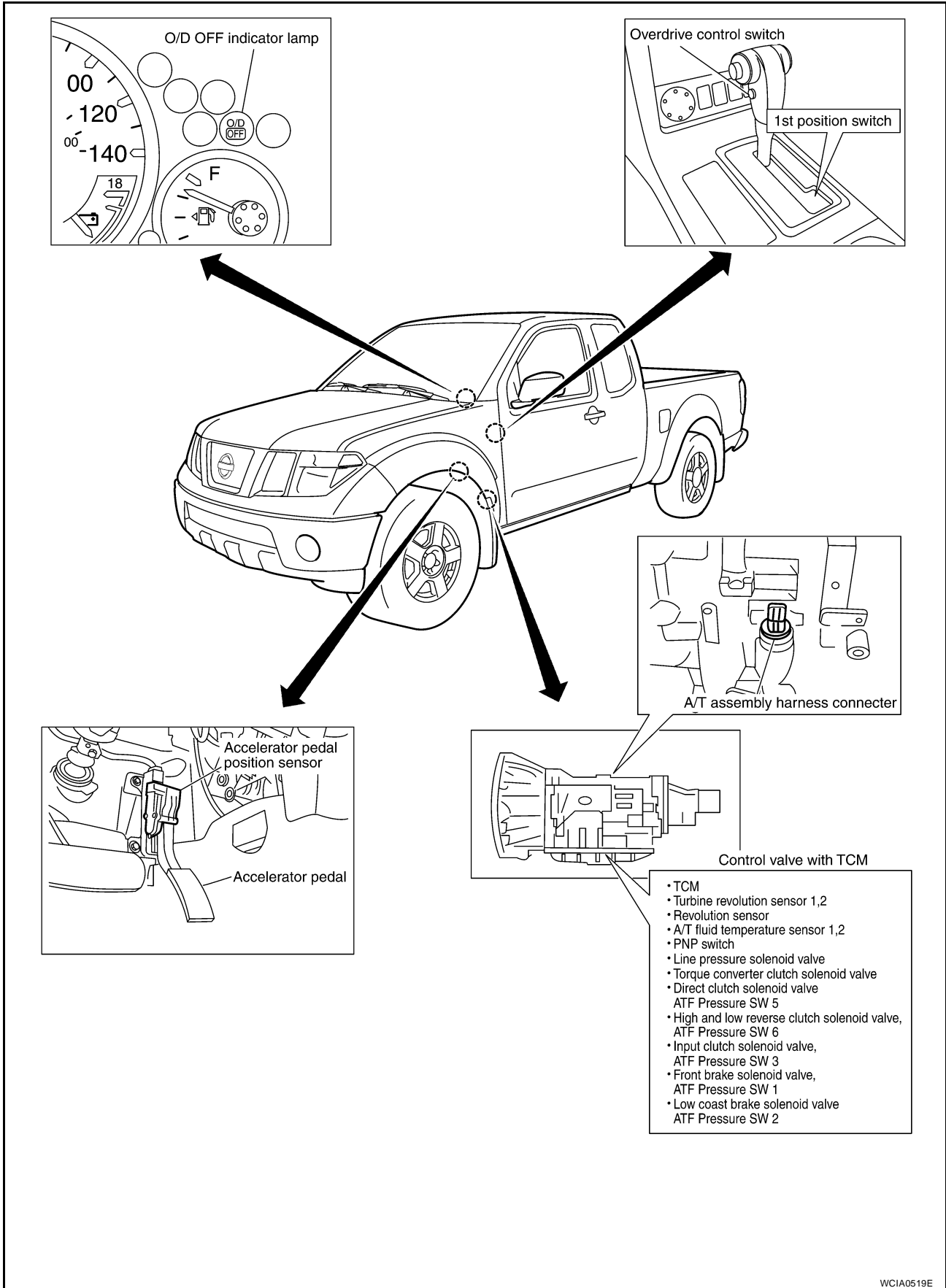

WCIA0519E

# TROUBLE DIAGNOSIS

## Schematic

UCS00425

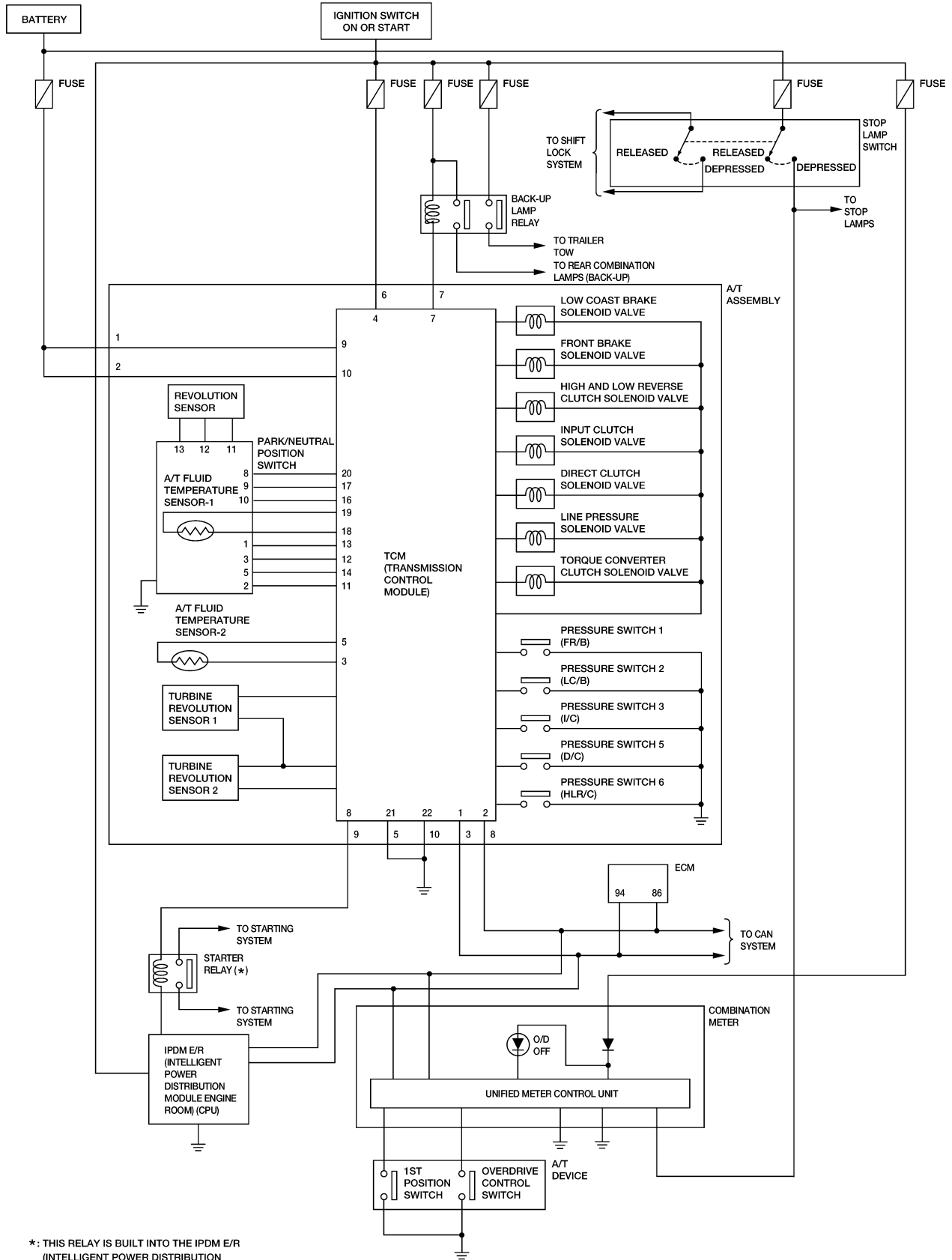

\*: THIS RELAY IS BUILT INTO THE IPDM E/R (INTELLIGENT POWER DISTRIBUTION MODULE ENGINE ROOM)

BCWA0578E

# TROUBLE DIAGNOSIS

UCS00426

## Inspections Before Trouble Diagnosis

### A/T FLUID CHECK

#### Fluid Leakage and Fluid Level Check

- Inspect for fluid leakage and check the fluid level. Refer to [AT-14, "Changing the A/T Fluid \(ATF\)"](#).

#### Fluid Condition Check

Inspect the fluid condition.

Fluid condition	Conceivable Cause	Required Operation
Varnished (viscous varnish state)	Clutch, brake scorched	Replace the ATF and check the A/T main unit and the vehicle for malfunctions (wire harnesses, cooler pipes, etc.)
Milky white or cloudy	Water in the fluid	Replace the ATF and check for places where water is getting in.
Large amount of metal powder mixed in	Unusual wear of sliding parts within A/T	Replace the ATF and check for improper operation of the A/T.

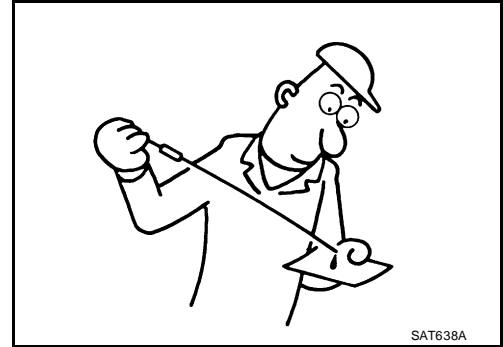

## STALL TEST

### Stall Test Procedure

- Inspect the amount of engine oil. Replenish the engine oil if necessary.
- Drive for about 10 minutes to warm up the vehicle so that the A/T fluid temperature is 50 to 80°C (122 to 176°F). Inspect the amount of ATF. Replenish if necessary.

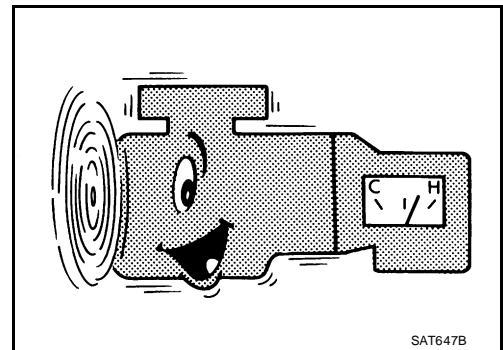

- Securely engage the parking brake so that the tires do not turn.

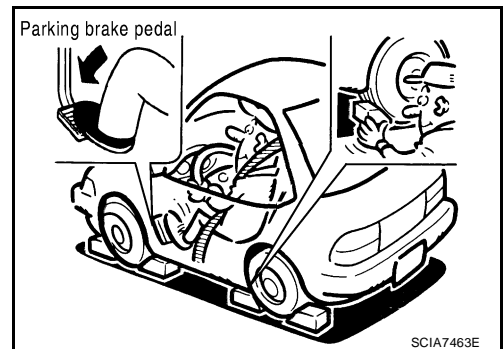

- Engine start, apply foot brake, and place selector lever in "D" position.
- While holding down the foot brake, gradually press down the accelerator pedal.
- Quickly read off the stall speed, then quickly remove your foot from the accelerator pedal.

**CAUTION:**

**Do not hold down the accelerator pedal for more than 5 seconds during this test.**

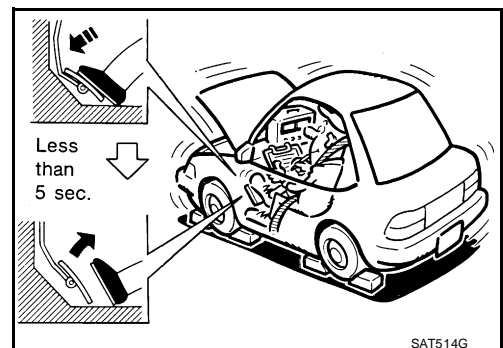

# TROUBLE DIAGNOSIS

## Stall speed:

QR25DE engine	2,350 - 2,650 rpm
VQ40DE engine	2,200 - 2,500 rpm

- Move the selector lever to the "N" position.
- Cool down the ATF.

### CAUTION:

Run the engine at idle for at least one minute.

- Repeat steps 5 through 8 with selector lever in "3", "2", "1" and "R" positions.

## Judgement of Stall Test

	Selector lever position		Expected problem location
	D, 3, 2, 1	R	
Stall rotation	H	O	<ul style="list-style-type: none"> <li>● Forward brake</li> <li>● Forward one-way clutch</li> <li>● 1st one-way clutch</li> <li>● 3rd one-way clutch</li> </ul>
	O	H	<ul style="list-style-type: none"> <li>● Reverse brake</li> </ul>
	L	L	<ul style="list-style-type: none"> <li>● Engine and torque converter one-way clutch</li> </ul>
	H	H	<ul style="list-style-type: none"> <li>● Line pressure low</li> </ul>

O: Stall speed within standard value position

H: Stall speed higher than standard value

L: Stall speed lower than standard value

## Stall test standard value position

Does not shift-up D position 1 → 2	Slipping in 2nd, 3rd, 4th gears	Direct clutch slippage
Does not shift-up D position 2 → 3	Slipping in 3rd, 4th, 5th gears	High and low reverse clutch slippage
Does not shift-up D position 3 → 4	Slipping in 4th, 5th gears	Input clutch slippage
Does not shift-up D position 4 → 5	Slipping in 5th gear	Front brake slippage

## LINE PRESSURE TEST

### Line Pressure Test Port

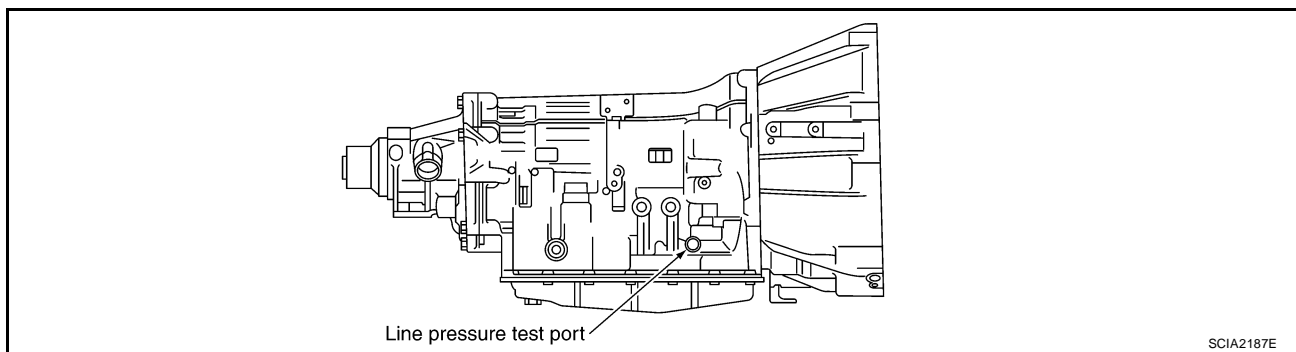

### Line Pressure Test Procedure

- Inspect the amount of engine oil and replenish if necessary.
- Drive the car for about 10 minutes to warm it up so that the ATF reaches in range of 50 to 80°C (122 to 176°F), then inspect the amount of ATF and replenish if necessary.

### NOTE:

The automatic fluid temperature rises in range of 50 to 80°C (122 to 176°F) during 10 minutes of driving.

# TROUBLE DIAGNOSIS

3. After warming up remove the oil pressure detection plug and install the oil pressure gauge [ST2505S001(J-34301-C)].

**CAUTION:**

**When using the oil pressure gauge, be sure to use the O-ring attached to the oil pressure detection plug.**

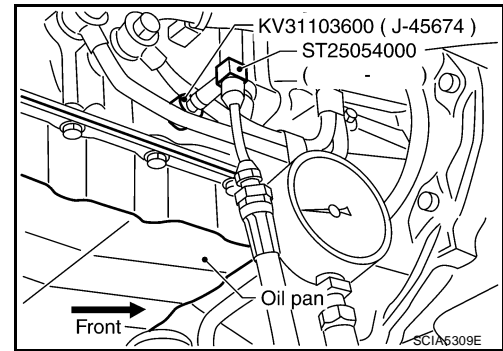

4. Securely engage the parking brake so that the tires do not turn.

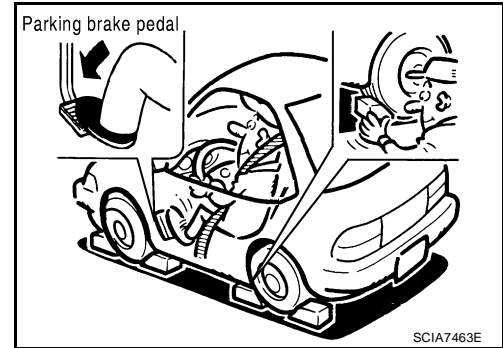

5. Start the engine, then measure the line pressure at both idle and the stall speed.

**CAUTION:**

- Keep the brake pedal pressed all the way down during measurement.
- When measuring the line pressure at the stall speed, refer to [AT-52. "STALL TEST"](#).

6. After the measurements are complete, install the oil pressure detection plug and tighten to the regulation torque below.

:7.3 N·m (0.74 kg·m, 65 in·lb)

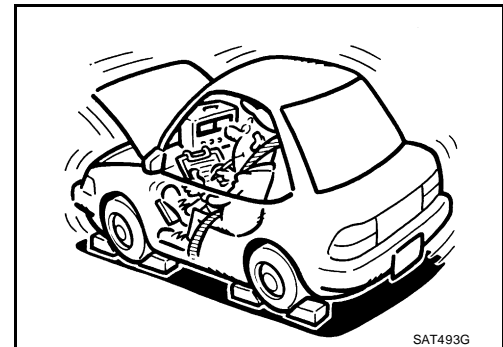

**CAUTION:**

- Do not reuse O-ring.
- Apply ATF to O-ring.

## Line Pressure

Engine speed	Line pressure [kPa (kg/cm <sup>2</sup> , psi)]	
	"R" position	"D" position
At idle speed	425-465 (4.3 - 4.7, 62 - 67)	379 - 428 (3.9 - 4.4, 55 - 62)
At stall speed	1,605 - 1,905 (16.4 - 19.9, 233 - 283)	1,310 - 1,500 (13.4 - 15.3, 190 - 218)

# TROUBLE DIAGNOSIS

## Judgement of Line Pressure Test

Judgement		Possible cause	
Idle speed	Low for all positions (P, R, N, D)	Possible causes include malfunctions in the pressure supply system and low oil pump output. For example <ul style="list-style-type: none"> <li>● Oil pump wear</li> <li>● Pressure regulator valve or plug sticking or spring fatigue</li> <li>● Oil strainer ⇒ oil pump ⇒ pressure regulator valve passage oil leak</li> <li>● Engine idle speed too low</li> </ul>	A B AT
	Only low for a specific position	Possible causes include an oil pressure leak in a passage or device related to the position after the pressure is distributed by the manual valve.	
	High	Possible causes include a sensor malfunction or malfunction in the line pressure adjustment function. For example <ul style="list-style-type: none"> <li>● Accelerator pedal position signal malfunction</li> <li>● ATF temperature sensor malfunction</li> <li>● Line pressure solenoid malfunction (sticking in "OFF" state, filter clog, cut line)</li> <li>● Pressure regulator valve or plug sticking</li> </ul>	D E F
Stall speed	Oil pressure does not rise higher than the oil pressure for idle.	Possible causes include a sensor malfunction or malfunction in the pressure adjustment function. For example <ul style="list-style-type: none"> <li>● Accelerator pedal position signal malfunction</li> <li>● TCM breakdown</li> <li>● Line pressure solenoid malfunction (shorting, sticking in "ON" state)</li> <li>● Pressure regulator valve or plug sticking</li> <li>● Pilot valve sticking or pilot filter clogged</li> </ul>	G H
	The pressure rises, but does not enter the standard position.	Possible causes include malfunctions in the pressure supply system and malfunction in the pressure adjustment function. For example <ul style="list-style-type: none"> <li>● Accelerator pedal position signal malfunction</li> <li>● Line pressure solenoid malfunction (sticking, filter clog)</li> <li>● Pressure regulator valve or plug sticking</li> <li>● Pilot valve sticking or pilot filter clogged</li> </ul>	I J
	Only low for a specific position	Possible causes include an oil pressure leak in a passage or device related to the position after the pressure is distributed by the manual valve.	K

## ROAD TEST

### Description

- The road test inspects overall performance of the A/T and analyzes possible malfunction causes.
  - The road test is carried out in the following three stages.
1. Check before engine is started. Refer to [AT-56](#) .
  2. Check at idle. Refer to [AT-56](#) .
  3. Cruise test
    - Inspect all the items from Part 1 to Part 3. Refer to [AT-57](#) , [AT-59](#) , [AT-60](#) .
    - Before beginning the road test, check the test procedure and inspection items.
    - Test all inspection items until the symptom is uncovered. Diagnose NG items when all road tests are complete.

# TROUBLE DIAGNOSIS

UCS00427

---

## Check Before Engine is Started

### 1. CHECK O/D OFF INDICATOR LAMP

---

1. Park vehicle on level surface.
2. Move selector lever to "P" position.
3. Turn ignition switch to "OFF" position and wait at least 10 seconds.
4. Turn ignition switch to "ON" position. (Do not start engine.)

Does O/D OFF indicator lamp light up for about 2 seconds?

YES >> 1. Turn ignition switch "OFF".

2. Perform self-diagnostics and record all NG items on the [AT-47, "DIAGNOSTIC WORKSHEET"](#) . Refer to [AT-89, "SELF-DIAGNOSTIC RESULT MODE"](#) , [AT-96, "Diagnostic Procedure Without CONSULT-II"](#) .

3. Go to [AT-56, "Check at Idle"](#) .

NO >> Stop the test and go to [AT-178, "O/D OFF Indicator Lamp Does Not Come On"](#) .

## Check at Idle

UCS00428

### 1. CHECK STARTING THE ENGINE

---

1. Park vehicle on level surface.
2. Move selector lever to "P" or "N" position.
3. Turn ignition switch to "OFF" position.
4. Turn ignition switch to "START" position.

Does the engine start?

YES >> GO TO 2.

NO >> Stop the road test and go to [AT-179, "Engine Cannot Be Started In "P" or "N" Position"](#) .

### 2. CHECK STARTING THE ENGINE

---

1. Turn ignition switch to "ON" position.
2. Move selector lever in "D", "3", "2", "1" or "R" position.
3. Turn ignition switch to "START" position.

Does the engine start in either position?

YES >> Stop the road test and go to [AT-179, "Engine Cannot Be Started In "P" or "N" Position"](#) .

NO >> GO TO 3.

### 3. CHECK "P" POSITION FUNCTIONS

---

1. Move selector lever to "P" position.
2. Turn ignition switch to "OFF" position.
3. Release the parking brake.
4. Push the vehicle forward or backward.
5. Engage the parking brake.

When you push the vehicle with disengaging the parking brake, does it move?

YES >> Enter a check mark at "In "P" Position Vehicle Moves When Pushed" on the diagnostics worksheet, then continue the road test.

NO >> GO TO 4.



# TROUBLE DIAGNOSIS

---

## 4. CHECK "N" POSITION FUNCTIONS

---

1. Start the engine.
2. Move selector lever to "N" position.
3. Release the parking brake.

Does vehicle move forward or backward?

- YES >> Enter a check mark at "In "N" Position Vehicle Moves" on the diagnostics worksheet, then continue the road test.
- NO >> GO TO 5.

---

## 5. CHECK SHIFT SHOCK

---

1. Engage the brake.
2. Move selector lever to "D" position.

When the transmission is shifted from "N" to "D", is there an excessive shock?

- YES >> Enter a check mark at "Large Shock ("N" to "D" Position)" on the diagnostics worksheet, then continue the road test.
- NO >> GO TO 6.

---

## 6. CHECK "R" POSITION FUNCTIONS

---

1. Engage the brake.
2. Move selector lever to "R" position.
3. Release the brake for 4 to 5 seconds.

Does the vehicle creep backward?

- YES >> GO TO 7.
- NO >> Enter a check mark at "Vehicle Does Not Creep Backward In "R" Position" on the diagnostics worksheet, then continue the road test.

---

## 7. CHECK "D" POSITION FUNCTIONS

---

Inspect whether the vehicle creep forward when the transmission is put into the "D" position.

Does the vehicle creep forward in the "D" positions?

- YES >> Go to [AT-57, "Cruise Test - Part 1"](#) , [AT-59, "Cruise Test - Part 2"](#) and [AT-60, "Cruise Test - Part 3"](#)
- NO >> Enter a check mark at "Vehicle Does Not Creep Forward In "D" Positions" on the diagnostics worksheet, then continue the road test.

### Cruise Test - Part 1

UCS00429

---

#### 1. CHECK STARTING OUT FROM D1

---

1. Drive the vehicle for about 10 minutes to warm up the engine oil and ATF.  
Appropriate temperature for the ATF: 50 - 80°C (122 - 176°F)
2. Park the vehicle on a level surface.
3. Move selector lever to "P" position.
4. Start the engine.
5. Set overdrive control switch to ON position.
6. Move selector lever to "D" position.
7. Press the accelerator pedal about half way down to accelerate the vehicle.

📖 **With CONSULT-II**

Read off the gear positions.

Starts from D1?

- YES >> GO TO 2.
- NO >> Enter a check mark at "Vehicle Cannot Be Started From D1" on the diagnostics worksheet, then continue the road test.

# TROUBLE DIAGNOSIS

---

## 2. CHECK SHIFT-UP D1 → D2

---

Press down the accelerator pedal about half way and inspect if the vehicle shifts up (D1 → D2) at the appropriate speed.

- Refer to [AT-61, "Vehicle Speed at Which Gear Shifting Occurs"](#) .

### ④ With CONSULT-II

Read the gear position, throttle degree of opening, and vehicle speed.

Does the A/T shift-up D1 → D2 at the correct speed?

YES >> GO TO 3.

NO >> Enter a check mark at "A/T Does Not Shift: D1 → D2" on the diagnostics worksheet, then continue the road test.

---

## 3. CHECK SHIFT-UP D2 → D3

---

Press down the accelerator pedal about half way and inspect if the vehicle shifts up (D2 → D3) at the appropriate speed.

- Refer to [AT-61, "Vehicle Speed at Which Gear Shifting Occurs"](#) .

### ④ With CONSULT-II

Read the gear position, throttle degree of opening, and vehicle speed.

Does the A/T shift-up D2 → D3 at the correct speed?

YES >> GO TO 4.

NO >> Enter a check mark at "A/T Does Not Shift: D2 → D3" on the diagnostics worksheet, then continue the road test.

---

## 4. CHECK SHIFT-UP D3 → D4

---

Press down the accelerator pedal about half way and inspect if the vehicle shifts up (D3 → D4) at the appropriate speed.

- Refer to [AT-61, "Vehicle Speed at Which Gear Shifting Occurs"](#) .

### ④ With CONSULT-II

Read the gear position, throttle degree of opening, and vehicle speed.

Does the A/T shift-up D3 → D4 at the correct speed?

YES >> GO TO 5.

NO >> Enter a check mark at "A/T Does Not Shift: D3 → D4" on the diagnostics worksheet, then continue the road test.

---

## 5. CHECK SHIFT-UP D4 → D5

---

Press down the accelerator pedal about half way and inspect if the vehicle shifts up (D4 → D5) at the appropriate speed.

- Refer to [AT-61, "Vehicle Speed at Which Gear Shifting Occurs"](#) .

### ④ With CONSULT-II

Read the gear position, throttle degree of opening, and vehicle speed.

Does the A/T shift-up D4 → D5 at the correct speed?

YES >> GO TO 6.

NO >> Enter a check mark at "A/T Does Not Shift: D4 → D5" on the diagnostics worksheet, then continue the road test.

# TROUBLE DIAGNOSIS

## 6. CHECK LOCK-UP

When releasing accelerator pedal from D5 (Closed throttle position signal: OFF), check lock-up from D5 to L/U.

- Refer to [AT-61, "Vehicle Speed at Which Gear Shifting Occurs"](#).

### Ⓜ With CONSULT-II

Select "TCC SOLENOID" with the "MAIN SIGNAL" mode for A/T.

Does it lock-up?

YES >> GO TO 7.

NO >> Enter a check mark at "A/T Does Not Perform Lock-up" on the diagnostics worksheet, then continue the road test.

## 7. CHECK LOCK-UP HOLD

Check hold lock-up.

### Ⓜ With CONSULT-II

Select "TCC SOLENOID" with the "MAIN SIGNAL" mode for A/T.

Does it maintain lock-up status?

YES >> GO TO 8.

NO >> Enter a check mark at "A/T Does Not Hold Lock-up Condition" on the diagnostics worksheet, then continue the road test.

## 8. CHECK LOCK-UP RELEASE

Check lock-up cancellation by depressing brake pedal lightly to decelerate.

### Ⓜ With CONSULT-II

Select "TCC SOLENOID" with the "MAIN SIGNAL" mode for A/T.

Does lock-up cancel?

YES >> GO TO 9.

NO >> Enter a check mark at "Lock-up Is Not Released" on the diagnostics worksheet, then continue the road test.

## 9. CHECK SHIFT-DOWN D5 → D4

Decelerate by pressing lightly on the brake pedal.

### Ⓜ With CONSULT-II

Read the gear position and engine speed.

When the A/T shift-down D5 → D4, does the engine speed drop smoothly back to idle?

YES >> 1. Stop the vehicle.

2. Go to Cruise test - Part 2 (Refer to [AT-59](#)).

NO >> Enter a check mark at "Engine Speed Does Not Return to Idle" on the diagnostics worksheet, then continue the road test. Go to Cruise test - Part 2 (Refer to [AT-59](#)).

## Cruise Test - Part 2

UCS0042A

### 1. CHECK STARTING FROM D1

1. Move selector lever to "D" position.
2. Set overdrive control switch to OFF position.
3. Accelerate at half throttle.

### Ⓜ With CONSULT-II

Read the gear position.

Does it start from D1?

YES >> GO TO 2.

NO >> Enter a check mark at "Vehicle Cannot Be Started From D1" on the diagnostics worksheet, then continue the road test.

# TROUBLE DIAGNOSIS

---

## 2. CHECK SHIFT-UP D1 → D2

---

Press the accelerator pedal down all the way and inspect whether or not the transmission shifts up (D1 → D2) at the correct speed.

- Refer to [AT-61, "Vehicle Speed at Which Gear Shifting Occurs"](#) .

### Ⓜ With CONSULT-II

Read the gear position, throttle position and vehicle speed.

Does the A/T shift-up D1 → D2 at the correct speed?

YES >> GO TO 3.

NO >> Enter a check mark at "A/T Does Not Shift: D1 → D2" on the diagnostics worksheet, then continue the road test.

---

## 3. CHECK SHIFT-UP D2 → D3

---

Press the accelerator pedal down all the way and inspect whether or not the transmission shifts up (D2 → D3) at the correct speed.

- Refer to [AT-61, "Vehicle Speed at Which Gear Shifting Occurs"](#) .

### Ⓜ With CONSULT-II

Read the gear position, throttle position and vehicle speed.

Does the A/T shift-up D2 → D3 at the correct speed?

YES >> GO TO 4.

NO >> Enter a check mark at "A/T Does Not Shift: D2 → D3" on the diagnostics worksheet, then continue the road test.

---

## 4. CHECK SHIFT-UP D3 → D4 AND ENGINE BRAKE

---

When the transmission changes speed D3 → D4, return the accelerator pedal.

### Ⓜ With CONSULT-II

Read the gear position.

Does the A/T shift-up D3 → D4 and apply the engine brake?

YES >> 1. Stop the vehicle.

2. See [AT-60, "Cruise Test - Part 3"](#) .

NO >> Enter a check mark at "A/T Does Not Shift: D3 → D4" on the diagnostics worksheet, then continue the road test.

## Cruise Test - Part 3

UCS0042B

---

### 1. CHECK SHIFT-DOWN

---

1. Confirm overdrive control switch is ON position.
2. Confirm gear selector lever is in "D" position.
3. Accelerate vehicle using half-throttle to D5 .
4. Release accelerator pedal.
5. Set overdrive control switch to OFF position while driving in D5 .

#### Ⓜ With CONSULT-II

Read the gear position.

Does A/T shift from D5 to D4 (O/D OFF)?

YES >> GO TO 2.

NO >> Enter a check mark at "A/T does not shift: 5th gear → 4th gear" on the diagnostics worksheet, then continue the road test.

# TROUBLE DIAGNOSIS

## 2. CHECK SHIFT-DOWN

During D4 driving, move gear selector from D → 3 → 2 → 1.

### With CONSULT-II

Read the gear position.

Is downshifting correctly performed?

YES >> GO TO 3.

NO >> Enter a check mark at "A/T does not shift" at the corresponding position (4th → 3rd, 3rd → 2nd, 2nd → 1st) on the diagnostics worksheet, then continue the road test.

## 3. CHECK ENGINE BRAKE

Does engine braking effectively reduce speed in 11 position?

YES >> 1. Stop the vehicle.

2. Carry out the self-diagnostics. Refer to [AT-89, "SELF-DIAGNOSTIC RESULT MODE"](#).

NO >> Enter a check mark at "Vehicle Does Not Decelerate By Engine Brake" on the diagnostics worksheet, then continue trouble diagnosis.

## Vehicle Speed at Which Gear Shifting Occurs

UCS0042C

### 2WD MODELS

A/T model code number		97X9E							
Tire size	Throttle position	Vehicle speed km/h (MPH)							
		D1 →D2	D2 →D3	D3 →D4	D4 →D5	D5 →D4	D4 →D3	D3 →D2	D2 →D1
P235/75R15	Full throttle	49 - 53 (30 - 33)	80 - 88 (50 - 55)	125 - 135 (78 - 84)	194 - 204 (121 - 127)	190 - 200 (118 - 124)	115 - 125 (72 - 78)	69 - 77 (43 - 48)	32 - 36 (20 - 23)
P265/70R16	Half throttle	36 - 40 (23 - 25)	59 - 65 (37 - 44)	91 - 99 (57 - 62)	128 - 136 (80 - 84)	99 - 107 (62 - 66)	63 - 71 (39 - 44)	44 - 50 (27 - 30)	11 - 15 (7 - 9)

- At half throttle, the accelerator opening is 1/2 of the full opening.

### 2WD MODELS

A/T model code number			98X0A							
Final gear ratio	Tire size	Throttle position	Vehicle speed km/h (MPH)							
			D1 →D2	D2 →D3	D3 →D4	D4 →D5	D5 →D4	D4 →D3	D3 →D2	D2 →D1
3.133	P265/75R16	Full throttle	66 - 74 (41 - 46)	108 - 118 (68 - 74)	166 - 182 (104 - 114)	242 - 266 (151 - 166)	238 - 262 (149 - 164)	154 - 170 (96 - 106)	94 - 104 (59 - 65)	42 - 48 (26 - 30)
		Half throttle	53 - 59 (33 - 37)	86 - 96 (54 - 60)	134 - 149 (84 - 93)	158 - 174 (99 - 109)	125 - 138 (78 - 86)	79 - 86 (49 - 53)	54 - 61 (34 - 38)	12 - 14 (7 - 9)
	P265/70R16 P265/65R17	Full throttle	60 - 68 (37 - 43)	99 - 110 (61 - 69)	153 - 170 (95 - 107)	234 - 259 (146 - 162)	230 - 255 (143 - 160)	142 - 158 (88 - 99)	87 - 97 (54 - 61)	41 - 47 (25 - 30)
		Half throttle	49 - 55 (30 - 35)	80 - 90 (50 - 57)	123 - 137 (76 - 86)	149 - 165 (93 - 103)	115 - 128 (71 - 80)	71 - 79 (44 - 50)	51 - 57 (31 - 36)	12 - 14 (7 - 9)
2.937	P265/70R16 P265/65R17	Full throttle	66 - 74 (41 - 46)	108 - 118 (68 - 74)	166 - 182 (104 - 114)	242 - 266 (151 - 166)	238 - 262 (149 - 164)	154 - 170 (96 - 106)	94 - 104 (59 - 65)	42 - 48 (26 - 30)
		Half throttle	53 - 59 (33 - 37)	86 - 96 (54 - 60)	134 - 149 (84 - 93)	158 - 174 (99 - 109)	125 - 137 (78 - 86)	79 - 85 (49 - 53)	54 - 61 (34 - 38)	12 - 14 (7 - 9)

- At half throttle, the accelerator opening is 1/2 of the full opening.

# TROUBLE DIAGNOSIS

## 4WD MODELS

A/T model code number			98X0B							
Final gear ratio	Tire size	Throttle position	Vehicle speed km/h (MPH)							
			D1 →D2	D2 →D3	D3 →D4	D4 →D5	D5 →D4	D4 →D3	D3 →D2	D2 →D1
3.357	P265/75R16	Full throttle	60 - 68 (37 - 42)	99 - 110 (61 - 69)	153 - 170 (95 - 107)	234 - 259 (146 - 162)	230 - 255 (143 - 160)	142 - 158 (88 - 99)	87 - 97 (54 - 61)	41 - 47 (25 - 30)
		Half throttle	49 - 55 (30 - 35)	80 - 90 (50 - 57)	123 - 137 (76 - 86)	149 - 165 (93 - 103)	115 - 128 (71 - 80)	71 - 79 (44 - 50)	51 - 57 (31 - 36)	12 - 14 (7 - 9)
	P265/70R16 P265/65R17	Full throttle	58 - 65 (36 - 41)	94 - 104 (58 - 65)	144 - 160 (90 - 100)	221 - 245 (138 - 154)	218 - 241 (136 - 151)	135 - 150 (84 - 94)	82 - 92 (51-58)	40 - 45 (25 - 29)
		Half throttle	46 - 52 (28 - 33)	76 - 84 (47 - 53)	117 - 130 (73 - 82)	140 - 156 (88 - 98)	109 - 121 (68 - 76)	67 - 75 (41 - 47)	48 - 54 (30 - 34)	12 - 14 (7 - 9)
3.133	P265/70R16 P265/65R17	Full throttle	60 - 68 (37 - 43)	99 - 110 (61 - 69)	153 - 170 (95 - 107)	234 - 259 (146 - 162)	230 - 255 (143 - 160)	142 - 158 (88 - 99)	87 - 97 (54 - 61)	41 - 47 (25 - 30)
		Half throttle	49 - 55 (30 - 35)	80 - 90 (50 - 57)	123 - 137 (76 - 85)	149 - 165 (93 - 103)	115 - 128 (71 - 80)	71 - 79 (44 - 50)	51 - 57 (31 - 36)	12 - 14 (7 - 9)

- At half throttle, the accelerator opening is 1/2 of the full opening.

## Vehicle Speed at Which Lock-up Occurs/Releases

ECS00/QA

### 2WD MODELS

A/T model code number		97X9E	
Tire size	Throttle position	Vehicle speed km/h (MPH)	
		Lock-up "ON"	Lock-up "OFF"
P235/75R15	Closed throttle	56 - 64 (35 - 40)	53 - 61 (33 - 37)
P265/70R16	Half throttle	161 - 169 (101 - 106)	126 - 134 (78 - 83)

- At closed throttle, the accelerator opening is less than 1/8 condition. (Closed throttle position signal: OFF)
- At half throttle, the accelerator opening is 1/2 of the full opening.

### 2WD MODELS

A/T model code number		98X0A		
Final gear ratio	Tire size	Throttle position	Vehicle speed km/h (MPH)	
			Lock-up "ON"	Lock-up "OFF"
3.133	P265/75R16	Closed throttle	71 - 79 (44 - 49)	68 - 76 (43 - 48)
		Half throttle	175 - 195 (109 - 122)	144 - 160 (90 - 100)
	P265/70R16 P265/65R17	Closed throttle	66 - 74 (41 - 46)	63 - 71 (39 - 44)
		Half throttle	166 - 186 (104 - 116)	132 - 148 (83 - 93)
2.937	P265/65R17 P265/70R16	Closed throttle	71 - 79 (44 - 49)	68 - 76 (43 - 48)
		Half throttle	175 - 195 (109 - 122)	144 - 160 (90 - 100)

- At closed throttle, the accelerator opening is less than 1/8 condition. (Closed throttle position signal: OFF)
- At half throttle, the accelerator opening is 1/2 of the full opening.

# TROUBLE DIAGNOSIS

## 4WD MODELS

A/T model code number		98X0B		
Final gear ratio	Tire size	Throttle position	Vehicle speed km/h (MPH)	
			Lock-up "ON"	Lock-up "OFF"
3.357	P265/75R16	Closed throttle	66 - 74 (41 - 46)	63 - 71 (39 - 44)
		Half throttle	166 - 186 (104 - 116)	132 - 148 (83 - 93)
	P265/70R16 P265/65R17	Closed throttle	62 - 70 (39 - 44)	59 - 67 (37 - 42)
		Half throttle	157 - 175 (98 - 109)	126 - 140 (79 - 88)
3.133	P265/65R17 P265/70R16	Closed throttle	66 - 74 (41 - 46)	63 - 71 (39 - 44)
		Half throttle	166 - 186 (104 - 116)	132 - 148 (83 - 93)

- At closed throttle, the accelerator opening is less than 1/8 condition. (Closed throttle position signal: OFF)
- At half throttle, the accelerator opening is 1/2 of the full opening.

A  
B  
AT  
D  
E  
F  
G  
H  
I  
J  
K  
L  
M

# TROUBLE DIAGNOSIS

UCS0042E

## Symptom Chart

- The diagnostics item numbers show the sequence for inspection. Inspect in order from item 1.
- Overhaul and inspect inside the A/T only if A/T fluid condition is NG. Refer to [AT-52, "Fluid Condition Check"](#) .

No.	Items	Symptom	Condition	Diagnostic Item	Reference page
1		Large shock. ("N" → "D" position) Refer to <a href="#">AT-182, "Large Shock ("N" to "D" Position)"</a> .	ON vehicle	1. Engine idle speed	<a href="#">EC-81 (QR)</a> , <a href="#">EC-686 (VQ)</a>
				2. Engine speed signal	<a href="#">AT-117</a>
				3. Accelerator pedal position sensor	<a href="#">AT-125</a>
				4. Control cable adjustment	<a href="#">AT-217</a>
				5. ATF temperature sensor	<a href="#">AT-128</a>
				6. ATF pressure switch 1 and front brake solenoid valve	<a href="#">AT-160</a> , <a href="#">AT-144</a>
				7. CAN communication line	<a href="#">AT-98</a>
				8. Fluid level and state	<a href="#">AT-52</a>
				9. Line pressure test	<a href="#">AT-53</a>
				10. Control valve with TCM	<a href="#">AT-229</a>
			OFF vehicle	11. Forward brake (Parts behind drum support is impossible to perform inspection by disassembly. Refer to <a href="#">AT-18</a> .)	<a href="#">AT-268</a>
2	Shift Shock	Shock is too large when changing D1 → D2 .	ON vehicle	1. Accelerator pedal position sensor	<a href="#">AT-125</a>
				2. Control cable adjustment	<a href="#">AT-217</a>
				3. ATF pressure switch 5 and direct clutch solenoid valve	<a href="#">AT-164</a> , <a href="#">AT-148</a>
				4. CAN communication line	<a href="#">AT-98</a>
				5. Engine speed signal	<a href="#">AT-117</a>
				6. Turbine revolution sensor	<a href="#">AT-110</a>
				7. Vehicle speed sensor A/T and vehicle speed sensor MTR	<a href="#">AT-112</a> , <a href="#">AT-133</a>
				8. Fluid level and state	<a href="#">AT-52</a>
				9. Control valve with TCM	<a href="#">AT-228</a>
			OFF vehicle	10. Direct clutch	<a href="#">AT-304</a>
3		Shock is too large when changing D2 → D3 .	ON vehicle	1. Accelerator pedal position sensor	<a href="#">AT-125</a>
				2. Control cable adjustment	<a href="#">AT-217</a>
				3. ATF pressure switch 6, high and low reverse clutch solenoid valve	<a href="#">AT-166</a> , <a href="#">AT-152</a>
				4. CAN communication line	<a href="#">AT-98</a>
				5. Engine speed signal	<a href="#">AT-117</a>
				6. Turbine revolution sensor	<a href="#">AT-110</a>
				7. Vehicle speed sensor A/T and vehicle speed sensor MTR	<a href="#">AT-112</a> , <a href="#">AT-133</a>
				8. Fluid level and state	<a href="#">AT-52</a>
				9. Control valve with TCM	<a href="#">AT-228</a>
			OFF vehicle	10. High and low reverse clutch	<a href="#">AT-301</a>



# TROUBLE DIAGNOSIS

No.	Items	Symptom	Condition	Diagnostic Item	Reference page
4		Shock is too large when changing D3 → D4 .	ON vehicle	1. Accelerator pedal position sensor	<a href="#">AT-125</a>
				2. Control cable adjustment	<a href="#">AT-217</a>
				3. ATF pressure switch 3 and input clutch solenoid valve	<a href="#">AT-162,</a> <a href="#">AT-140</a>
				4. CAN communication line	<a href="#">AT-98</a>
				5. Engine speed signal	<a href="#">AT-117</a>
				6. Turbine revolution sensor	<a href="#">AT-110</a>
				7. Vehicle speed sensor A/T and vehicle speed sensor MTR	<a href="#">AT-112,</a> <a href="#">AT-133</a>
				8. Fluid level and state	<a href="#">AT-52</a>
				9. Control valve with TCM	<a href="#">AT-228</a>
			OFF vehicle	10. Input clutch	<a href="#">AT-290</a>
5	Shift Shock	Shock is too large when changing D4 → D5 .	ON vehicle	1. Accelerator pedal position sensor	<a href="#">AT-125</a>
				2. Control cable adjustment	<a href="#">AT-217</a>
				3. ATF pressure switch 1 and front brake solenoid valve	<a href="#">AT-160,</a> <a href="#">AT-144</a>
				4. CAN communication line	<a href="#">AT-98</a>
				5. Engine speed signal	<a href="#">AT-117</a>
				6. Turbine revolution sensor	<a href="#">AT-110</a>
				7. Vehicle speed sensor A/T and vehicle speed sensor MTR	<a href="#">AT-112,</a> <a href="#">AT-133</a>
				8. Fluid level and state	<a href="#">AT-52</a>
				9. Control valve with TCM	<a href="#">AT-228</a>
			OFF vehicle	10. Front brake (brake band)	<a href="#">AT-254</a>
				11. Input clutch	<a href="#">AT-290</a>
6		Shock is too large for downshift when accelerator pedal is pressed.	ON vehicle	1. Accelerator pedal position sensor	<a href="#">AT-125</a>
				2. Control cable adjustment	<a href="#">AT-217</a>
				3. CAN communication line	<a href="#">AT-98</a>
				4. Engine speed signal	<a href="#">AT-117</a>
				5. Turbine revolution sensor	<a href="#">AT-110</a>
				6. Vehicle speed sensor A/T and vehicle speed sensor MTR	<a href="#">AT-112,</a> <a href="#">AT-133</a>
				7. Fluid level and state	<a href="#">AT-52</a>
				8. Control valve with TCM	<a href="#">AT-228</a>
			OFF vehicle	9. Front brake (brake band)	<a href="#">AT-254</a>
				10. Input clutch	<a href="#">AT-290</a>
				11. High and low reverse clutch	<a href="#">AT-301</a>
				12. Direct clutch	<a href="#">AT-304</a>

A  
B  
AT  
D  
E  
F  
G  
H  
I  
J  
K  
L  
M

# TROUBLE DIAGNOSIS

No.	Items	Symptom	Condition	Diagnostic Item	Reference page
7		Shock is too large for upshift when accelerator pedal is released.	ON vehicle	1. Accelerator pedal position sensor	<a href="#">AT-125</a>
				2. Control cable adjustment	<a href="#">AT-217</a>
				3. Engine speed signal	<a href="#">AT-117</a>
				4. CAN communication line	<a href="#">AT-98</a>
				5. Turbine revolution sensor	<a href="#">AT-110</a>
				6. Vehicle speed sensor A/T and vehicle speed sensor MTR	<a href="#">AT-112,</a> <a href="#">AT-133</a>
				7. Fluid level and state	<a href="#">AT-52</a>
				8. Control valve with TCM	<a href="#">AT-228</a>
			OFF vehicle	9. Front brake (brake band)	<a href="#">AT-254</a>
				10. Input clutch	<a href="#">AT-290</a>
				11. High and low reverse clutch	<a href="#">AT-301</a>
				12. Direct clutch	<a href="#">AT-304</a>
8	Shift Shock	Shock is too large for lock-up.	ON vehicle	1. Accelerator pedal position sensor	<a href="#">AT-125</a>
				2. Control cable adjustment	<a href="#">AT-217</a>
				3. Engine speed signal	<a href="#">AT-117</a>
				4. CAN communication line	<a href="#">AT-98</a>
				5. Turbine revolution sensor	<a href="#">AT-110</a>
				6. Vehicle speed sensor A/T and vehicle speed sensor MTR	<a href="#">AT-112,</a> <a href="#">AT-133</a>
				7. Torque converter clutch solenoid valve	<a href="#">AT-119</a>
				8. Fluid level and state	<a href="#">AT-52</a>
				9. Control valve with TCM	<a href="#">AT-228</a>
			OFF vehicle	10. Torque converter	<a href="#">AT-268</a>
9		Shock is too large during engine brake.	ON vehicle	1. Accelerator pedal position sensor	<a href="#">AT-125</a>
				2. Control cable adjustment	<a href="#">AT-217</a>
				3. CAN communication line	<a href="#">AT-98</a>
				4. Fluid level and state	<a href="#">AT-52</a>
				5. Control valve with TCM	<a href="#">AT-228</a>
			OFF vehicle	6. Front brake (brake band)	<a href="#">AT-254</a>
				7. Input clutch	<a href="#">AT-290</a>
				8. High and low reverse clutch	<a href="#">AT-301</a>
				9. Direct clutch	<a href="#">AT-304</a>

# TROUBLE DIAGNOSIS

No.	Items	Symptom	Condition	Diagnostic Item	Reference page			
10		Gear does not change from D1 → D2 . Refer to <a href="#">AT-191, "A/T Does Not Shift: D1 → D2"</a> .	ON vehicle	1. Fluid level and state	<a href="#">AT-52</a>			
				2. Vehicle speed sensor A/T and vehicle speed sensor MTR	<a href="#">AT-112, AT-133</a>			
				3. ATF pressure switch 5 and direct clutch solenoid valve	<a href="#">AT-164, AT-148</a>			
				4. Line pressure test	<a href="#">AT-53</a>			
				5. CAN communication line	<a href="#">AT-98</a>			
				6. Control valve with TCM	<a href="#">AT-228</a>			
			OFF vehicle	7. Direct clutch	<a href="#">AT-304</a>			
11		Gear does not change from D2 → D3 . Refer to <a href="#">AT-193, "A/T Does Not Shift: D2 → D3"</a> .	ON vehicle	1. Fluid level and state	<a href="#">AT-52</a>			
				2. Vehicle speed sensor A/T and vehicle speed sensor MTR	<a href="#">AT-112, AT-133</a>			
				3. ATF pressure switch 6, high and low reverse clutch solenoid valve	<a href="#">AT-166, AT-152</a>			
				4. Line pressure test	<a href="#">AT-53</a>			
				5. CAN communication line	<a href="#">AT-98</a>			
				6. Control valve with TCM	<a href="#">AT-228</a>			
			OFF vehicle	7. High and low reverse clutch	<a href="#">AT-301</a>			
12	No Up Shift	Gear does not change from D3 → D4 . Refer to <a href="#">AT-195, "A/T Does Not Shift: D3 → D4"</a> .	ON vehicle	1. Fluid level and state	<a href="#">AT-52</a>			
				2. Vehicle speed sensor A/T and vehicle speed sensor MTR	<a href="#">AT-112, AT-133</a>			
				3. ATF pressure switch 3 and input clutch solenoid valve	<a href="#">AT-162, AT-140</a>			
				4. ATF pressure switch 1 and front brake solenoid valve	<a href="#">AT-160, AT-144</a>			
				5. Line pressure test	<a href="#">AT-53</a>			
				6. CAN communication line	<a href="#">AT-98</a>			
				7. Control valve with TCM	<a href="#">AT-228</a>			
			OFF vehicle	8. Input clutch	<a href="#">AT-290</a>			
13		Gear does not change from D4 → D5 . Refer to <a href="#">AT-197, "A/T Does Not Shift: D4 → D5"</a> .	ON vehicle	1. Fluid level and state	<a href="#">AT-52</a>			
				2. Vehicle speed sensor A/T and vehicle speed sensor MTR	<a href="#">AT-112, AT-133</a>			
				3. ATF pressure switch 1 and front brake solenoid valve	<a href="#">AT-160, AT-144</a>			
				4. ATF pressure switch 5 and direct clutch solenoid valve	<a href="#">AT-164, AT-148</a>			
				5. Turbine revolution sensor	<a href="#">AT-110</a>			
				6. Line pressure test	<a href="#">AT-53</a>			
				7. CAN communication line	<a href="#">AT-98</a>			
				8. Control valve with TCM	<a href="#">AT-228</a>			
						OFF vehicle	9. Front brake (brake band)	<a href="#">AT-268</a>
							10. Input clutch	<a href="#">AT-290</a>

A  
B  
AT  
D  
E  
F  
G  
H  
I  
J  
K  
L  
M

# TROUBLE DIAGNOSIS

No.	Items	Symptom	Condition	Diagnostic Item	Reference page			
14		In "D" range, does not downshift to 4th gear. Refer to <a href="#">AT-206, "A/T Does Not Shift: 5th gear → 4th gear"</a> .	ON vehicle	1. Fluid level and state	<a href="#">AT-52</a>			
				2. Vehicle speed sensor A/T and vehicle speed sensor MTR	<a href="#">AT-112, AT-133</a>			
				3. ATF pressure switch 1 and front brake solenoid valve	<a href="#">AT-160, AT-144</a>			
				4. ATF pressure switch 5 and direct clutch solenoid valve	<a href="#">AT-164, AT-148</a>			
				5. CAN communication line	<a href="#">AT-98</a>			
				6. Line pressure test	<a href="#">AT-53</a>			
				7. Control valve with TCM	<a href="#">AT-228</a>			
			OFF vehicle	8. Front brake (brake band)	<a href="#">AT-268</a>			
				9. Input clutch	<a href="#">AT-290</a>			
15	No Down Shift	In "D" or "3"range, does not downshift to 3rd gear. Refer to <a href="#">AT-208, "A/T Does Not Shift: 4th gear → 3rd gear"</a> .	ON vehicle	1. Fluid level and state	<a href="#">AT-52</a>			
				2. Vehicle speed sensor A/T and vehicle speed sensor MTR	<a href="#">AT-112, AT-133</a>			
				3. ATF pressure switch 3 and input clutch solenoid valve	<a href="#">AT-162, AT-140</a>			
				4. ATF pressure switch 1 and front brake solenoid valve	<a href="#">AT-160, AT-144</a>			
				5. CAN communication line	<a href="#">AT-98</a>			
				6. Line pressure test	<a href="#">AT-53</a>			
				7. Control valve with TCM	<a href="#">AT-228</a>			
			OFF vehicle	8. Input clutch	<a href="#">AT-290</a>			
			16		In "D" or "2" range, does not downshift to 2nd gear. Refer to <a href="#">AT-210, "A/T Does Not Shift: 3rd gear → 2nd gear"</a> .	ON vehicle	1. Fluid level and state	<a href="#">AT-52</a>
2. Vehicle speed sensor A/T and vehicle speed sensor MTR	<a href="#">AT-112, AT-133</a>							
3. ATF pressure switch 6, high and low reverse clutch solenoid valve	<a href="#">AT-166, AT-152</a>							
4. CAN communication line	<a href="#">AT-98</a>							
5. Line pressure test	<a href="#">AT-53</a>							
6. Control valve with TCM	<a href="#">AT-228</a>							
OFF vehicle	7. High and low reverse clutch	<a href="#">AT-301</a>						
17		In "D" or "1" range, does not downshift to 1st gear. Refer to <a href="#">AT-212, "A/T Does Not Shift: 2nd gear → 1st gear"</a> .				ON vehicle	1. Fluid level and state	<a href="#">AT-52</a>
							2. Vehicle speed sensor A/T and vehicle speed sensor MTR	<a href="#">AT-112, AT-133</a>
			3. ATF pressure switch 5 and direct clutch solenoid valve	<a href="#">AT-164, AT-148</a>				
			4. CAN communication line	<a href="#">AT-98</a>				
			5. Line pressure test	<a href="#">AT-53</a>				
			6. Control valve with TCM	<a href="#">AT-228</a>				
			OFF vehicle	7. Direct clutch	<a href="#">AT-304</a>			

# TROUBLE DIAGNOSIS

No.	Items	Symptom	Condition	Diagnostic Item	Reference page
18	Slips/Will Not engage	When "D" position, remains in 1st gear.	ON vehicle	1. Fluid level and state	<a href="#">AT-52</a>
				2. Vehicle speed sensor A/T and vehicle speed sensor MTR	<a href="#">AT-112</a> , <a href="#">AT-133</a>
				3. Direct clutch solenoid valve	<a href="#">AT-148</a>
				4. Line pressure test	<a href="#">AT-53</a>
				5. CAN communication line	<a href="#">AT-98</a>
				6. Control valve with TCM	<a href="#">AT-228</a>
			OFF vehicle	7. 3rd one-way clutch	<a href="#">AT-288</a>
				8. 1st one-way clutch	<a href="#">AT-296</a>
				9. Gear system	<a href="#">AT-254</a>
				10. Reverse brake	<a href="#">AT-268</a>
				11. Forward one-way clutch (Parts behind drum support is impossible to perform inspection by disassembly. Refer to <a href="#">AT-18</a> .)	<a href="#">AT-268</a>
				12. Forward brake (Parts behind drum support is impossible to perform inspection by disassembly. Refer to <a href="#">AT-18</a> .)	<a href="#">AT-268</a>
19		When "D" position, remains in 2nd gear.	ON vehicle	1. Fluid level and state	<a href="#">AT-52</a>
				2. Vehicle speed sensor A/T and vehicle speed sensor MTR	<a href="#">AT-112</a> , <a href="#">AT-133</a>
				3. Low coast brake solenoid valve	<a href="#">AT-156</a>
				4. Line pressure test	<a href="#">AT-53</a>
				5. CAN communication line	<a href="#">AT-98</a>
				6. Control valve with TCM	<a href="#">AT-228</a>
			OFF vehicle	7. 3rd one-way clutch	<a href="#">AT-288</a>
				8. Gear system	<a href="#">AT-254</a>
				9. Direct clutch	<a href="#">AT-304</a>
				10. Forward brake (Parts behind drum support is impossible to perform inspection by disassembly. Refer to <a href="#">AT-18</a> .)	<a href="#">AT-268</a>

A  
B  
AT  
D  
E  
F  
G  
H  
I  
J  
K  
L  
M

# TROUBLE DIAGNOSIS

No.	Items	Symptom	Condition	Diagnostic Item	Reference page
20		When "D" position, remains in 3rd gear.	ON vehicle	1. Fluid level and state	<a href="#">AT-52</a>
				2. Vehicle speed sensor A/T and vehicle speed sensor MTR	<a href="#">AT-112, AT-133</a>
				3. Line pressure test	<a href="#">AT-53</a>
				4. CAN communication line	<a href="#">AT-98</a>
				5. Control valve with TCM	<a href="#">AT-228</a>
			OFF vehicle	6. 3rd one-way clutch	<a href="#">AT-288</a>
				7. Gear system	<a href="#">AT-254</a>
				8. High and low reverse clutch	<a href="#">AT-301</a>
				9. Forward one-way clutch (Parts behind drum support is impossible to perform inspection by disassembly. Refer to <a href="#">AT-18</a> .)	<a href="#">AT-268</a>
				10. Forward brake (Parts behind drum support is impossible to perform inspection by disassembly. Refer to <a href="#">AT-18</a> .)	<a href="#">AT-268</a>
21	Slips/Will Not engage	When "D" position, remains in 4th gear.	ON vehicle	1. Fluid level and state	<a href="#">AT-52</a>
				2. Vehicle speed sensor A/T and vehicle speed sensor MTR	<a href="#">AT-112, AT-133</a>
				3. ATF pressure switch 3 and input clutch solenoid valve	<a href="#">AT-162, AT-140</a>
				4. ATF pressure switch 5 and direct clutch solenoid valve	<a href="#">AT-164, AT-148</a>
				5. ATF pressure switch 6, high and low reverse clutch solenoid valve	<a href="#">AT-166, AT-152</a>
				6. Low coast brake solenoid valve	<a href="#">AT-156</a>
				7. Front brake solenoid valve	<a href="#">AT-144</a>
				8. Line pressure test	<a href="#">AT-53</a>
				9. CAN communication line	<a href="#">AT-98</a>
				10. Control valve with TCM	<a href="#">AT-228</a>
			OFF vehicle	11. Input clutch	<a href="#">AT-290</a>
				12. Gear system	<a href="#">AT-254</a>
				13. High and low reverse clutch	<a href="#">AT-301</a>
				14. Direct clutch	<a href="#">AT-304</a>

# TROUBLE DIAGNOSIS

No.	Items	Symptom	Condition	Diagnostic Item	Reference page
22		When "D" position, remains in 5th gear.	ON vehicle	1. Fluid level and state	<a href="#">AT-52</a>
				2. Vehicle speed sensor A/T and vehicle speed sensor MTR	<a href="#">AT-112,</a> <a href="#">AT-133</a>
				3. ATF pressure switch 1 and front brake solenoid valve	<a href="#">AT-160,</a> <a href="#">AT-144</a>
				4. Line pressure test	<a href="#">AT-53</a>
				5. CAN communication line	<a href="#">AT-98</a>
				6. Control valve with TCM	<a href="#">AT-228</a>
			OFF vehicle	7. Front brake (brake band)	<a href="#">AT-268</a>
				8. Input clutch	<a href="#">AT-290</a>
				9. Gear system	<a href="#">AT-254</a>
				10. High and low reverse clutch	<a href="#">AT-301</a>
23	Slips/Will Not Engage	Vehicle cannot be started from D1 . Refer to <a href="#">AT-189</a> . " <a href="#">Vehicle Cannot Be Started From D1</a> ".	ON vehicle	1. Fluid level and state	<a href="#">AT-52</a>
				2. Accelerator pedal position sensor	<a href="#">AT-125</a>
				3. Line pressure test	<a href="#">AT-53</a>
				4. CAN communication line	<a href="#">AT-98</a>
				5. Control valve with TCM	<a href="#">AT-228</a>
			OFF vehicle	6. Torque converter	<a href="#">AT-268</a>
				7. Oil pump assembly	<a href="#">AT-285</a>
				8. 3rd one-way clutch	<a href="#">AT-288</a>
				9. 1st one-way clutch	<a href="#">AT-296</a>
				10. Gear system	<a href="#">AT-254</a>
				11. Reverse brake	<a href="#">AT-268</a>
				12. Forward one-way clutch (Parts behind drum support is impossible to perform inspection by disassembly. Refer to <a href="#">AT-18</a> .)	<a href="#">AT-268</a>
				13. Forward brake (Parts behind drum support is impossible to perform inspection by disassembly. Refer to <a href="#">AT-18</a> .)	<a href="#">AT-268</a>
24		Does not lock-up. Refer to <a href="#">AT-199</a> . " <a href="#">A/T Does Not Perform Lock-up</a> ".	ON vehicle	1. Fluid level and state	<a href="#">AT-52</a>
				2. Line pressure test	<a href="#">AT-53</a>
				3. Engine speed signal	<a href="#">AT-117</a>
				4. Turbine revolution sensor	<a href="#">AT-110</a>
				5. Torque converter clutch solenoid valve	<a href="#">AT-119</a>
				6. CAN communication line	<a href="#">AT-98</a>
				7. Control valve with TCM	<a href="#">AT-228</a>
			OFF vehicle	8. Torque converter	<a href="#">AT-268</a>
				9. Oil pump assembly	<a href="#">AT-285</a>

A

B

AT

D

E

F

G

H

I

J

K

L

M

# TROUBLE DIAGNOSIS

No.	Items	Symptom	Condition	Diagnostic Item	Reference page	
25	Slips/Will Not engage	Does not hold lock-up condition. Refer to <a href="#">AT-201, "A/T Does Not Hold Lock-up Condition"</a> .	ON vehicle	1. Fluid level and state	<a href="#">AT-52</a>	
				2. Line pressure test	<a href="#">AT-53</a>	
				3. Engine speed signal	<a href="#">AT-117</a>	
				4. Turbine revolution sensor	<a href="#">AT-110</a>	
				5. Torque converter clutch solenoid valve	<a href="#">AT-119</a>	
				6. CAN communication line	<a href="#">AT-98</a>	
				7. Control valve with TCM	<a href="#">AT-228</a>	
			OFF vehicle	8. Torque converter	<a href="#">AT-268</a>	
				9. Oil pump assembly	<a href="#">AT-285</a>	
26		Slips/Will Not engage	Lock-up is not released. Refer to <a href="#">AT-203, "Lock-up Is Not Released"</a> .	ON vehicle	1. Fluid level and state	<a href="#">AT-52</a>
					2. Line pressure test	<a href="#">AT-53</a>
					3. Engine speed signal	<a href="#">AT-117</a>
					4. Turbine revolution sensor	<a href="#">AT-110</a>
					5. Torque converter clutch solenoid valve	<a href="#">AT-119</a>
					6. CAN communication line	<a href="#">AT-98</a>
					7. Control valve with TCM	<a href="#">AT-228</a>
				OFF vehicle	8. Torque converter	<a href="#">AT-268</a>
					9. Oil pump assembly	<a href="#">AT-285</a>
27	Slips/Will Not engage		No shock at all or the clutch slips when vehicle changes speed D1 → D2 .	ON vehicle	1. Fluid level and state	<a href="#">AT-52</a>
					2. Vehicle speed sensor A/T and vehicle speed sensor MTR	<a href="#">AT-112, AT-133</a>
					3. ATF pressure switch 5 and direct clutch solenoid valve	<a href="#">AT-164, AT-148</a>
					4. CAN communication line	<a href="#">AT-98</a>
					5. Line pressure test	<a href="#">AT-53</a>
					6. Control valve with TCM	<a href="#">AT-228</a>
				OFF vehicle	7. Torque converter	<a href="#">AT-268</a>
					8. Oil pump assembly	<a href="#">AT-285</a>
					9. 3rd one-way clutch	<a href="#">AT-288</a>
		10. Gear system			<a href="#">AT-254</a>	
		11. Direct clutch			<a href="#">AT-304</a>	
		12. Forward brake (Parts behind drum support is impossible to perform inspection by disassembly. Refer to <a href="#">AT-18</a> .)			<a href="#">AT-268</a>	



# TROUBLE DIAGNOSIS

No.	Items	Symptom	Condition	Diagnostic Item	Reference page
28	Slips/Will Not engage	No shock at all or the clutch slips when vehicle changes speed D2 → D3 .	ON vehicle	1. Fluid level and state	<a href="#">AT-52</a>
				2. Vehicle speed sensor A/T and vehicle speed sensor MTR	<a href="#">AT-112, AT-133</a>
				3. ATF pressure switch 6, high and low reverse clutch solenoid valve	<a href="#">AT-166, AT-152</a>
				4. CAN communication line	<a href="#">AT-98</a>
				5. Line pressure test	<a href="#">AT-53</a>
				6. Control valve with TCM	<a href="#">AT-228</a>
			OFF vehicle	7. Torque converter	<a href="#">AT-268</a>
				8. Oil pump assembly	<a href="#">AT-285</a>
				9. 3rd one-way clutch	<a href="#">AT-288</a>
				10. Gear system	<a href="#">AT-254</a>
				11. High and low reverse clutch	<a href="#">AT-301</a>
				12. Forward one- way clutch (Parts behind drum support is impossible to perform inspection by disassembly. Refer to <a href="#">AT-18</a> .)	<a href="#">AT-268</a>
				13. Forward brake (Parts behind drum support is impossible to perform inspection by disassembly. Refer to <a href="#">AT-18</a> .)	<a href="#">AT-268</a>
29	Slips/Will Not engage	No shock at all or the clutch slips when vehicle changes speed D3 → D4 .	ON vehicle	1. Fluid level and state	<a href="#">AT-52</a>
				2. Vehicle speed sensor A/T and vehicle speed sensor MTR	<a href="#">AT-112, AT-133</a>
				3. ATF pressure switch 3 and input clutch solenoid valve	<a href="#">AT-162, AT-140</a>
				4. ATF pressure switch 1 and front brake solenoid valve	<a href="#">AT-160, AT-144</a>
				5. CAN communication line	<a href="#">AT-98</a>
				6. Line pressure test	<a href="#">AT-53</a>
				7. Control valve with TCM	<a href="#">AT-228</a>
			OFF vehicle	8. Torque converter	<a href="#">AT-268</a>
				9. Oil pump assembly	<a href="#">AT-285</a>
				10. Input clutch	<a href="#">AT-290</a>
				11. Gear system	<a href="#">AT-254</a>
				12. High and low reverse clutch	<a href="#">AT-301</a>
				13. Direct clutch	<a href="#">AT-304</a>

A  
B  
AT  
D  
E  
F  
G  
H  
I  
J  
K  
L  
M

# TROUBLE DIAGNOSIS

No.	Items	Symptom	Condition	Diagnostic Item	Reference page
30	Slips/Will Not engage	No shock at all or the clutch slips when vehicle changes speed D4 → D5 .	ON vehicle	1. Fluid level and state	<a href="#">AT-52</a>
				2. Vehicle speed sensor A/T and vehicle speed sensor MTR	<a href="#">AT-112,</a> <a href="#">AT-133</a>
				3. ATF pressure switch 1 and front brake solenoid valve	<a href="#">AT-160,</a> <a href="#">AT-144</a>
				4. ATF pressure switch 5 and direct clutch solenoid valve	<a href="#">AT-164,</a> <a href="#">AT-148</a>
				5. CAN communication line	<a href="#">AT-98</a>
				6. Line pressure test	<a href="#">AT-53</a>
				7. Control valve with TCM	<a href="#">AT-228</a>
			OFF vehicle	8. Torque converter	<a href="#">AT-268</a>
				9. Oil pump assembly	<a href="#">AT-285</a>
				10. Front brake (brake band)	<a href="#">AT-268</a>
				11. Input clutch	<a href="#">AT-290</a>
				12. Gear system	<a href="#">AT-254</a>
				13. High and low reverse clutch	<a href="#">AT-301</a>
31	Slips/Will Not engage	When you press the accelerator pedal and shift speed D5 → D4 the engine idles or the transmission slips.	ON vehicle	1. Fluid level and state	<a href="#">AT-52</a>
				2. Vehicle speed sensor A/T and vehicle speed sensor MTR	<a href="#">AT-112,</a> <a href="#">AT-133</a>
				3. ATF pressure switch 1 and front brake solenoid valve	<a href="#">AT-160,</a> <a href="#">AT-144</a>
				4. ATF pressure switch 5 and direct clutch solenoid valve	<a href="#">AT-164,</a> <a href="#">AT-148</a>
				5. CAN communication line	<a href="#">AT-98</a>
				6. Line pressure test	<a href="#">AT-53</a>
				7. Control valve with TCM	<a href="#">AT-228</a>
			OFF vehicle	8. Torque converter	<a href="#">AT-268</a>
				9. Oil pump assembly	<a href="#">AT-285</a>
				10. Input clutch	<a href="#">AT-290</a>
				11. Gear system	<a href="#">AT-254</a>
				12. High and low reverse clutch	<a href="#">AT-301</a>
				13. Direct clutch	<a href="#">AT-304</a>

# TROUBLE DIAGNOSIS

No.	Items	Symptom	Condition	Diagnostic Item	Reference page	
32	Slips/Will Not engage	When you press the accelerator pedal and shift speed D4 → D3 the engine idles or the transmission slips.	ON vehicle	1. Fluid level and state	<a href="#">AT-52</a>	A
				2. Vehicle speed sensor A/T and vehicle speed sensor MTR	<a href="#">AT-112,</a> <a href="#">AT-133</a>	B
				3. ATF pressure switch 3 and input clutch solenoid valve	<a href="#">AT-162,</a> <a href="#">AT-140</a>	AT
				4. ATF pressure switch 1 and front brake solenoid valve	<a href="#">AT-160,</a> <a href="#">AT-144</a>	
				5. CAN communication line	<a href="#">AT-98</a>	D
				6. Line pressure test	<a href="#">AT-53</a>	
				7. Control valve with TCM	<a href="#">AT-228</a>	
			OFF vehicle	8. Torque converter	<a href="#">AT-268</a>	E
				9. Oil pump assembly	<a href="#">AT-285</a>	
				10. 3rd one-way clutch	<a href="#">AT-288</a>	F
				11. Gear system	<a href="#">AT-254</a>	
				12. High and low reverse clutch	<a href="#">AT-301</a>	G
				13. Forward one- way clutch (Parts behind drum support is impossible to perform inspection by disassembly. Refer to <a href="#">AT-18</a> .)	<a href="#">AT-268</a>	
				14. Forward brake (Parts behind drum support is impossible to perform inspection by disassembly. Refer to <a href="#">AT-18</a> .)	<a href="#">AT-268</a>	H
33		When you press the accelerator pedal and shift speed D3 → D2 the engine idles or the transmission slips.	ON vehicle	1. Fluid level and state	<a href="#">AT-52</a>	I
				2. Vehicle speed sensor A/T and vehicle speed sensor MTR	<a href="#">AT-112,</a> <a href="#">AT-133</a>	J
				3. ATF pressure switch 6, high and low reverse clutch solenoid valve	<a href="#">AT-166,</a> <a href="#">AT-152</a>	K
				4. ATF pressure switch 5 and direct clutch solenoid valve	<a href="#">AT-164,</a> <a href="#">AT-148</a>	
				5. CAN communication line	<a href="#">AT-98</a>	L
				6. Line pressure test	<a href="#">AT-53</a>	
				7. Control valve with TCM	<a href="#">AT-228</a>	
			OFF vehicle	8. Torque converter	<a href="#">AT-268</a>	M
				9. Oil pump assembly	<a href="#">AT-285</a>	
				10. 3rd one-way clutch	<a href="#">AT-288</a>	
				11. Gear system	<a href="#">AT-254</a>	
				12. Direct clutch	<a href="#">AT-304</a>	
				13. Forward brake (Parts behind drum support is impossible to perform inspection by disassembly. Refer to <a href="#">AT-18</a> .)	<a href="#">AT-268</a>	

# TROUBLE DIAGNOSIS

No.	Items	Symptom	Condition	Diagnostic Item	Reference page
34	Slips/Will Not Engage	When you press the accelerator pedal and shift speed D2 → D1 the engine idles or the transmission slips.	ON vehicle	1. Fluid level and state	<a href="#">AT-52</a>
				2. Vehicle speed sensor A/T and vehicle speed sensor MTR	<a href="#">AT-112</a> , <a href="#">AT-133</a>
				3. ATF pressure switch 5 and direct clutch solenoid valve	<a href="#">AT-164</a> , <a href="#">AT-148</a>
				4. CAN communication line	<a href="#">AT-98</a>
				5. Line pressure test	<a href="#">AT-53</a>
				6. Control valve with TCM	<a href="#">AT-228</a>
			OFF vehicle	7. Torque converter	<a href="#">AT-268</a>
				8. Oil pump assembly	<a href="#">AT-285</a>
				9. 3rd one-way clutch	<a href="#">AT-288</a>
				10. 1st one-way clutch	<a href="#">AT-296</a>
				11. Gear system	<a href="#">AT-254</a>
				12. Reverse brake	<a href="#">AT-268</a>
				13. Forward one- way clutch (Parts behind drum support is impossible to perform inspection by disassembly. Refer to <a href="#">AT-18</a> .)	<a href="#">AT-268</a>
				14. Forward brake (Parts behind drum support is impossible to perform inspection by disassembly. Refer to <a href="#">AT-18</a> .)	<a href="#">AT-268</a>
35	With selector lever in "D" position, acceleration is extremely poor.		ON vehicle	1. Fluid level and state	<a href="#">AT-52</a>
				2. Line pressure test	<a href="#">AT-53</a>
				3. Accelerator pedal position sensor	<a href="#">AT-125</a>
				4. CAN communication line	<a href="#">AT-98</a>
				5. PNP switch	<a href="#">AT-106</a>
				6. Control cable adjustment	<a href="#">AT-217</a>
				7. Control valve with TCM	<a href="#">AT-228</a>
			OFF vehicle	8. Torque converter	<a href="#">AT-268</a>
				9. Oil pump assembly	<a href="#">AT-285</a>
				10. 1st one-way clutch	<a href="#">AT-296</a>
				11. Gear system	<a href="#">AT-254</a>
				12. Reverse brake	<a href="#">AT-268</a>
				13. Forward one- way clutch (Parts behind drum support is impossible to perform inspection by disassembly. Refer to <a href="#">AT-18</a> .)	<a href="#">AT-268</a>
				14. Forward brake (Parts behind drum support is impossible to perform inspection by disassembly. Refer to <a href="#">AT-18</a> .)	<a href="#">AT-268</a>

# TROUBLE DIAGNOSIS

No.	Items	Symptom	Condition	Diagnostic Item	Reference page
36		With selector lever in "R" position, acceleration is extremely poor.	ON vehicle	1. Fluid level and state	<a href="#">AT-52</a>
				2. Line pressure test	<a href="#">AT-53</a>
				3. Accelerator pedal position sensor	<a href="#">AT-125</a>
				4. ATF pressure switch 6, high and low reverse clutch solenoid valve	<a href="#">AT-166,</a> <a href="#">AT-152</a>
				5. CAN communication line	<a href="#">AT-98</a>
				6. PNP switch	<a href="#">AT-106</a>
				7. Control cable adjustment	<a href="#">AT-217</a>
				8. Control valve with TCM	<a href="#">AT-228</a>
			OFF vehicle	9. Gear system	<a href="#">AT-254</a>
				10. Output shaft	<a href="#">AT-268</a>
				11. Reverse brake	<a href="#">AT-268</a>
37	Slips/Will Not Engage	While starting off by accelerating in 1st, engine races or slippage occurs.	ON vehicle	1. Fluid level and state	<a href="#">AT-52</a>
				2. Line pressure test	<a href="#">AT-53</a>
				3. Accelerator pedal position sensor	<a href="#">AT-125</a>
				4. CAN communication line	<a href="#">AT-98</a>
				5. Control valve with TCM	<a href="#">AT-228</a>
			OFF vehicle	6. Torque converter	<a href="#">AT-268</a>
				7. Oil pump assembly	<a href="#">AT-285</a>
				8. 3rd one-way clutch	<a href="#">AT-288</a>
				9. 1st one-way clutch	<a href="#">AT-296</a>
				10. Gear system	<a href="#">AT-254</a>
				11. Reverse brake	<a href="#">AT-268</a>
				12. Forward one-way clutch (Parts behind drum support is impossible to perform inspection by disassembly. Refer to <a href="#">AT-18</a> .)	<a href="#">AT-268</a>
				13. Forward brake (Parts behind drum support is impossible to perform inspection by disassembly. Refer to <a href="#">AT-18</a> .)	<a href="#">AT-268</a>
38		While accelerating in 2nd, engine races or slippage occurs.	ON vehicle	1. Fluid level and state	<a href="#">AT-52</a>
				2. Line pressure test	<a href="#">AT-53</a>
				3. Accelerator pedal position sensor	<a href="#">AT-125</a>
				4. CAN communication line	<a href="#">AT-98</a>
				5. ATF pressure switch 5 and direct clutch solenoid valve	<a href="#">AT-164,</a> <a href="#">AT-148</a>
				6. Control valve with TCM	<a href="#">AT-228</a>
			OFF vehicle	7. Torque converter	<a href="#">AT-268</a>
				8. Oil pump assembly	<a href="#">AT-285</a>
				9. 3rd one-way clutch	<a href="#">AT-288</a>
				10. Gear system	<a href="#">AT-254</a>
				11. Direct clutch	<a href="#">AT-304</a>
				12. Forward brake (Parts behind drum support is impossible to perform inspection by disassembly. Refer to <a href="#">AT-18</a> .)	<a href="#">AT-304</a>

A  
B  
AT  
D  
E  
F  
G  
H  
I  
J  
K  
L  
M

# TROUBLE DIAGNOSIS

No.	Items	Symptom	Condition	Diagnostic Item	Reference page
39	Slips/Will Not Engage	While accelerating in 3rd, engine races or slippage occurs.	ON vehicle	1. Fluid level and state	<a href="#">AT-52</a>
				2. Line pressure test	<a href="#">AT-53</a>
				3. Accelerator pedal position sensor	<a href="#">AT-125</a>
				4. CAN communication line	<a href="#">AT-98</a>
				5. ATF pressure switch 6, high and low reverse clutch solenoid valve	<a href="#">AT-166</a> , <a href="#">AT-152</a>
				6. Control valve with TCM	<a href="#">AT-228</a>
			OFF vehicle	7. Torque converter	<a href="#">AT-268</a>
				8. Oil pump assembly	<a href="#">AT-285</a>
				9. 3rd one-way clutch	<a href="#">AT-288</a>
				10. Gear system	<a href="#">AT-254</a>
				11. High and low reverse clutch	<a href="#">AT-301</a>
				12. Forward one- way clutch (Parts behind drum support is impossible to perform inspection by disassembly. Refer to <a href="#">AT-18</a> .)	<a href="#">AT-268</a>
				13. Forward brake (Parts behind drum support is impossible to perform inspection by disassembly. Refer to <a href="#">AT-18</a> .)	<a href="#">AT-268</a>
40		While accelerating in 4th, engine races or slippage occurs.	ON vehicle	1. Fluid level and state	<a href="#">AT-52</a>
				2. Line pressure test	<a href="#">AT-53</a>
				3. Accelerator pedal position sensor	<a href="#">AT-125</a>
				4. CAN communication line	<a href="#">AT-98</a>
				5. ATF pressure switch 3 and input clutch solenoid valve	<a href="#">AT-162</a> , <a href="#">AT-140</a>
				6. Control valve with TCM	<a href="#">AT-228</a>
			OFF vehicle	7. Torque converter	<a href="#">AT-268</a>
				8. Oil pump assembly	<a href="#">AT-285</a>
				9. Input clutch	<a href="#">AT-290</a>
				10. Gear system	<a href="#">AT-254</a>
				11. High and low reverse clutch	<a href="#">AT-301</a>
				12. Direct clutch	<a href="#">AT-304</a>

# TROUBLE DIAGNOSIS

No.	Items	Symptom	Condition	Diagnostic Item	Reference page			
41		While accelerating in 5th, engine races or slippage occurs.	ON vehicle	1. Fluid level and state	<a href="#">AT-52</a>			
				2. Line pressure test	<a href="#">AT-53</a>			
				3. Accelerator pedal position sensor	<a href="#">AT-125</a>			
				4. CAN communication line	<a href="#">AT-98</a>			
				5. ATF pressure switch 1 and front brake solenoid valve	<a href="#">AT-160,</a> <a href="#">AT-144</a>			
				6. Control valve with TCM	<a href="#">AT-228</a>			
			OFF vehicle	7. Torque converter	<a href="#">AT-268</a>			
				8. Oil pump assembly	<a href="#">AT-285</a>			
				9. Front brake (brake band)	<a href="#">AT-268</a>			
				10. Input clutch	<a href="#">AT-290</a>			
				11. Gear system	<a href="#">AT-254</a>			
				12. High and low reverse clutch	<a href="#">AT-301</a>			
42	Slips/Will Not Engage	Slips at lock-up.	ON vehicle	1. Fluid level and state	<a href="#">AT-52</a>			
				2. Line pressure test	<a href="#">AT-53</a>			
				3. Engine speed signal	<a href="#">AT-117</a>			
				4. Turbine revolution sensor	<a href="#">AT-110</a>			
				5. Torque converter clutch solenoid valve	<a href="#">AT-119</a>			
				6. CAN communication line	<a href="#">AT-98</a>			
				7. Control valve with TCM	<a href="#">AT-228</a>			
			OFF vehicle	8. Torque converter	<a href="#">AT-268</a>			
				9. Oil pump assembly	<a href="#">AT-285</a>			
				43	No creep at all. Refer to <a href="#">AT-184</a> , <a href="#">"Vehicle Does Not Creep Backward In "R" Position"</a> , <a href="#">AT-187</a> , <a href="#">"Vehicle Does Not Creep Forward In "D" Position"</a>	ON vehicle	1. Fluid level and state	<a href="#">AT-52</a>
							2. Line pressure test	<a href="#">AT-53</a>
							3. Accelerator pedal position sensor	<a href="#">AT-125</a>
4. ATF pressure switch 5 and direct clutch solenoid valve	<a href="#">AT-164,</a> <a href="#">AT-148</a>							
5. PNP switch	<a href="#">AT-106</a>							
6. CAN communication line	<a href="#">AT-98</a>							
7. Control cable adjustment	<a href="#">AT-217</a>							
8. Control valve with TCM	<a href="#">AT-228</a>							
OFF vehicle	9. Torque converter	<a href="#">AT-268</a>						
	10. Oil pump assembly	<a href="#">AT-285</a>						
	11. 1st one-way clutch	<a href="#">AT-296</a>						
	12. Gear system	<a href="#">AT-254</a>						
	13. Reverse brake	<a href="#">AT-268</a>						
	14. Direct clutch	<a href="#">AT-304</a>						
	15. Forward one- way clutch (Parts behind drum support is impossible to perform inspection by disassembly. Refer to <a href="#">AT-18</a> .)	<a href="#">AT-268</a>						
	16. Forward brake (Parts behind drum support is impossible to perform inspection by disassembly. Refer to <a href="#">AT-18</a> .)	<a href="#">AT-268</a>						

A  
B  
AT  
D  
E  
F  
G  
H  
I  
J  
K  
L  
M

## TROUBLE DIAGNOSIS

No.	Items	Symptom	Condition	Diagnostic Item	Reference page
44		Vehicle cannot run in all positions.	ON vehicle	1. Fluid level and state	<a href="#">AT-52</a>
				2. Line pressure test	<a href="#">AT-53</a>
				3. PNP switch	<a href="#">AT-106</a>
				4. Control cable adjustment	<a href="#">AT-217</a>
				5. Control valve with TCM	<a href="#">AT-228</a>
			OFF vehicle	6. Oil pump assembly	<a href="#">AT-285</a>
				7. Gear system	<a href="#">AT-254</a>
				8. Output shaft	<a href="#">AT-268</a>
45	Slips/Will Not Engage	With selector lever in "D" position, driving is not possible.	ON vehicle	1. Fluid level and state	<a href="#">AT-52</a>
				2. Line pressure test	<a href="#">AT-53</a>
				3. PNP switch	<a href="#">AT-106</a>
				4. Control cable adjustment	<a href="#">AT-217</a>
				5. Control valve with TCM	<a href="#">AT-228</a>
			OFF vehicle	6. Torque converter	<a href="#">AT-268</a>
				7. Oil pump assembly	<a href="#">AT-285</a>
				8. 1st one-way clutch	<a href="#">AT-296</a>
				9. Gear system	<a href="#">AT-254</a>
				10. Reverse brake	<a href="#">AT-268</a>
				11. Forward one- way clutch (Parts behind drum support is impossible to perform inspection by disassembly. Refer to <a href="#">AT-18</a> .)	<a href="#">AT-268</a>
				12. Forward brake (Parts behind drum support is impossible to perform inspection by disassembly. Refer to <a href="#">AT-18</a> .)	<a href="#">AT-268</a>
46		With selector lever in "R" position, driving is not possible.	ON vehicle	1. Fluid level and state	<a href="#">AT-52</a>
				2. Line pressure test	<a href="#">AT-53</a>
				3. PNP switch	<a href="#">AT-106</a>
				4. Control cable adjustment	<a href="#">AT-217</a>
				5. Control valve with TCM	<a href="#">AT-228</a>
			OFF vehicle	6. Gear system	<a href="#">AT-254</a>
				7. Output shaft	<a href="#">AT-268</a>
				8. Reverse brake	<a href="#">AT-268</a>
47	Others	Shift point is high in "D" position.	ON vehicle	1. Vehicle speed sensor A/T and vehicle speed sensor MTR	<a href="#">AT-112</a> , <a href="#">AT-133</a>
				2. Accelerator pedal position sensor	<a href="#">AT-125</a>
				3. CAN communication line	<a href="#">AT-98</a>
				4. ATF temperature sensor	<a href="#">AT-128</a>
				5. Control valve with TCM	<a href="#">AT-228</a>



# TROUBLE DIAGNOSIS

No.	Items	Symptom	Condition	Diagnostic Item	Reference page
48		Shift point is low in "D" position.	ON vehicle	1. Vehicle speed sensor A/T and vehicle speed sensor MTR	<a href="#">AT-112</a> , <a href="#">AT-133</a>
				2. Accelerator pedal position sensor	<a href="#">AT-125</a>
				3. CAN communication line	<a href="#">AT-98</a>
				4. Control valve with TCM	<a href="#">AT-228</a>
49		Judder occurs during lock-up.	ON vehicle	1. Fluid level and state	<a href="#">AT-52</a>
				2. Engine speed signal	<a href="#">AT-117</a>
				3. Turbine revolution sensor	<a href="#">AT-110</a>
				4. Vehicle speed sensor A/T and vehicle speed sensor MTR	<a href="#">AT-112</a> , <a href="#">AT-133</a>
			OFF vehicle	5. Accelerator pedal position sensor	<a href="#">AT-125</a>
				6. CAN communication line	<a href="#">AT-98</a>
				7. Torque converter clutch solenoid valve	<a href="#">AT-119</a>
				8. Control valve with TCM	<a href="#">AT-228</a>
50	Others	Strange noise in "R" position.	ON vehicle	1. Fluid level and state	<a href="#">AT-52</a>
				2. Engine speed signal	<a href="#">AT-117</a>
				3. CAN communication line	<a href="#">AT-98</a>
				4. Control valve with TCM	<a href="#">AT-228</a>
			OFF vehicle	5. Torque converter	<a href="#">AT-268</a>
				6. Oil pump assembly	<a href="#">AT-285</a>
				7. Gear system	<a href="#">AT-254</a>
				8. High and low reverse clutch	<a href="#">AT-301</a>
				9. Reverse brake	<a href="#">AT-268</a>
51		Strange noise in "N" position.	ON vehicle	1. Fluid level and state	<a href="#">AT-52</a>
				2. Engine speed signal	<a href="#">AT-117</a>
				3. CAN communication line	<a href="#">AT-98</a>
				4. Control valve with TCM	<a href="#">AT-228</a>
			OFF vehicle	5. Torque converter	<a href="#">AT-268</a>
				6. Oil pump assembly	<a href="#">AT-285</a>
				7. Gear system	<a href="#">AT-254</a>
52		Strange noise in "D" position.	ON vehicle	1. Fluid level and state	<a href="#">AT-52</a>
				2. Engine speed signal	<a href="#">AT-117</a>
				3. CAN communication line	<a href="#">AT-98</a>
				4. Control valve with TCM	<a href="#">AT-228</a>
			OFF vehicle	5. Torque converter	<a href="#">AT-268</a>
				6. Oil pump assembly	<a href="#">AT-285</a>
				7. Gear system	<a href="#">AT-254</a>
				8. Forward brake (Parts behind drum support is impossible to perform inspection by disassembly. Refer to <a href="#">AT-18</a> .)	<a href="#">AT-268</a>

A  
B  
AT  
D  
E  
F  
G  
H  
I  
J  
K  
L  
M

## TROUBLE DIAGNOSIS

No.	Items	Symptom	Condition	Diagnostic Item	Reference page
53		Vehicle dose not decelerate by engine brake. Refer to <a href="#">AT-214</a> , " <a href="#">Vehicle Does Not Decelerate By Engine Brake</a> ".	ON vehicle	1. PNP switch	<a href="#">AT-106</a>
				2. Fluid level and state	<a href="#">AT-52</a>
				3. Control cable adjustment	<a href="#">AT-217</a>
				4. 1st position switch	<a href="#">AT-214</a>
				5. ATF pressure switch 5	<a href="#">AT-164</a>
				6. CAN communication line	<a href="#">AT-98</a>
				7. Control valve with TCM	<a href="#">AT-228</a>
			OFF vehicle	8. Input clutch	<a href="#">AT-290</a>
				9. High and low reverse clutch	<a href="#">AT-301</a>
				10. Direct clutch	<a href="#">AT-304</a>
54	Others	Engine brake does not operate in "2" position.	ON vehicle	1. PNP switch	<a href="#">AT-106</a>
				2. Fluid level and state	<a href="#">AT-52</a>
				3. Control cable adjustment	<a href="#">AT-217</a>
				5. ATF pressure switch 6	<a href="#">AT-166</a>
				6. CAN communication line	<a href="#">AT-98</a>
				7. Control valve with TCM	<a href="#">AT-228</a>
				OFF vehicle	8. Front brake (brake band)
			9. Input clutch		<a href="#">AT-290</a>
			10. High and low reverse clutch		<a href="#">AT-301</a>
			55		Engine brake does not operate in "1" position.
2. Fluid level and state	<a href="#">AT-52</a>				
3. Control cable adjustment	<a href="#">AT-217</a>				
4. 1st position switch	<a href="#">AT-214</a>				
5. ATF pressure switch 5	<a href="#">AT-164</a>				
6. CAN communication line	<a href="#">AT-98</a>				
7. Control valve with TCM	<a href="#">AT-228</a>				
OFF vehicle	8. Input clutch	<a href="#">AT-290</a>			
	9. High and low reverse clutch	<a href="#">AT-301</a>			
	10. Direct clutch	<a href="#">AT-304</a>			

# TROUBLE DIAGNOSIS

No.	Items	Symptom	Condition	Diagnostic Item	Reference page
56	Others	Maximum speed low.	ON vehicle	1. Fluid level and state	<a href="#">AT-52</a>
				2. Line pressure test	<a href="#">AT-53</a>
				3. Accelerator pedal position sensor	<a href="#">AT-125</a>
				4. CAN communication line	<a href="#">AT-98</a>
				5. Direct clutch solenoid valve	<a href="#">AT-148</a>
				6. Control valve with TCM	<a href="#">AT-228</a>
			OFF vehicle	7. Torque converter	<a href="#">AT-268</a>
				8. Oil pump assembly	<a href="#">AT-285</a>
				9. Input clutch	<a href="#">AT-290</a>
				10. Gear system	<a href="#">AT-254</a>
				11. High and low reverse clutch	<a href="#">AT-301</a>
				12. Direct clutch	<a href="#">AT-304</a>
				13. Forward one- way clutch (Parts behind drum support is impossible to perform inspection by disassembly. Refer to <a href="#">AT-18</a> .)	<a href="#">AT-268</a>
				14 Forward brake (Parts behind drum support is impossible to perform inspection by disassembly. Refer to <a href="#">AT-18</a> .)	<a href="#">AT-268</a>
57	Others	Extremely large creep.	ON vehicle	1. Engine idle speed	<a href="#">EC-81 (QR)</a> , <a href="#">EC-686 (VQ)</a>
				2. CAN communication line	<a href="#">AT-98</a>
				3. ATF pressure switch 5	<a href="#">AT-164</a>
			OFF vehicle	4. Torque converter	<a href="#">AT-268</a>
			ON vehicle	1. PNP switch	<a href="#">AT-106</a>
				2. Control cable adjustment	<a href="#">AT-217</a>
58	Others	With selector lever in "P" position, vehicle does not enter parking condition or, with selector lever in another position, parking condition is not cancelled. Refer to <a href="#">AT-180</a> , " <a href="#">In "P" Position, Vehicle Moves When Pushed</a> " .	ON vehicle	3. Parking pawl components	<a href="#">AT-254</a>
			OFF vehicle		
59	Others	Vehicle runs with transmission in "P" position.	ON vehicle	1. PNP switch	<a href="#">AT-106</a>
				2. Fluid level and state	<a href="#">AT-52</a>
				3. Control cable adjustment	<a href="#">AT-217</a>
				4. Control valve with TCM	<a href="#">AT-228</a>
				5. Parking pawl components	<a href="#">AT-254</a>
			OFF vehicle	6. Gear system	<a href="#">AT-254</a>

A  
B  
AT  
D  
E  
F  
G  
H  
I  
J  
K  
L  
M

# TROUBLE DIAGNOSIS

No.	Items	Symptom	Condition	Diagnostic Item	Reference page
60		Vehicle runs with transmission in "N" position. Refer to <a href="#">AT-181, "In "N" Position, Vehicle Moves"</a> .	ON vehicle	1. PNP switch	<a href="#">AT-106</a>
				2. Fluid level and state	<a href="#">AT-52</a>
				3. Control cable adjustment	<a href="#">AT-217</a>
				4. Control valve with TCM	<a href="#">AT-228</a>
			OFF vehicle	5. Input clutch	<a href="#">AT-290</a>
				6. Gear system	<a href="#">AT-254</a>
				7. Direct clutch	<a href="#">AT-304</a>
				8. Reverse brake	<a href="#">AT-268</a>
				9. Forward one- way clutch (Parts behind drum support is impossible to perform inspection by disassembly. Refer to <a href="#">AT-18</a> .)	<a href="#">AT-268</a>
				10. Forward brake (Parts behind drum support is impossible to perform inspection by disassembly. Refer to <a href="#">AT-18</a> .)	<a href="#">AT-268</a>
61	Others	Engine does not start in "N" or "P" position. Refer to <a href="#">AT-179, "Engine Cannot Be Started In "P" or "N" Position"</a> .	ON vehicle	1. Ignition switch and starter	<a href="#">PG-4, SC-10</a>
				2. Control cable adjustment	<a href="#">AT-217</a>
				3. PNP switch	<a href="#">AT-106</a>
62	Others	Engine starts in positions other than "N" or "P".	ON vehicle	1. Ignition switch and starter	<a href="#">PG-4, SC-10</a>
				2. Control cable adjustment	<a href="#">AT-217</a>
				3. PNP switch	<a href="#">AT-106</a>
63		Engine stall.	ON vehicle	1. Fluid level and state	<a href="#">AT-52</a>
				2. Engine speed signal	<a href="#">AT-117</a>
				3. Turbine revolution sensor	<a href="#">AT-110</a>
				4. Torque converter clutch solenoid valve	<a href="#">AT-119</a>
				5. CAN communication line	<a href="#">AT-98</a>
				6. Control valve with TCM	<a href="#">AT-228</a>
			OFF vehicle	7. Torque converter	<a href="#">AT-268</a>
64		Engine stalls when select lever shifted "N" → "D", "R".	ON vehicle	1. Fluid level and state	<a href="#">AT-52</a>
				2. Engine speed signal	<a href="#">AT-117</a>
				3. Turbine revolution sensor	<a href="#">AT-110</a>
				4. Torque converter clutch solenoid valve	<a href="#">AT-119</a>
				5. CAN communication line	<a href="#">AT-98</a>
				6. Control valve with TCM	<a href="#">AT-228</a>
			OFF vehicle	7. Torque converter	<a href="#">AT-268</a>

# TROUBLE DIAGNOSIS

No.	Items	Symptom	Condition	Diagnostic Item	Reference page
65	Others	Engine speed does not return to idle. Refer to <a href="#">AT-204</a> , " <a href="#">Engine Speed Does Not Return to Idle</a> ".	ON vehicle	1. Fluid level and state	<a href="#">AT-52</a>
				2. ATF pressure switch 5 and direct clutch solenoid valve	<a href="#">AT-164</a> , <a href="#">AT-148</a>
				3. ATF pressure switch 1 and front brake solenoid valve	<a href="#">AT-160</a> , <a href="#">AT-144</a>
				4. Accelerator pedal position sensor	<a href="#">AT-125</a>
				5. Vehicle speed sensor A/T and vehicle speed sensor MTR	<a href="#">AT-112</a> , <a href="#">AT-133</a>
				6. CAN communication line	<a href="#">AT-98</a>
				7. Control valve with TCM	<a href="#">AT-228</a>
			OFF vehicle	8. Front brake (brake band)	<a href="#">AT-268</a>
			9. Direct clutch	<a href="#">AT-304</a>	

A  
B  
AT  
D  
E  
F  
G  
H  
I  
J  
K  
L  
M

# TROUBLE DIAGNOSIS

## TCM Input/Output Signal Reference Values A/T ASSEMBLY HARNESS CONNECTOR TERMINAL LAYOUT



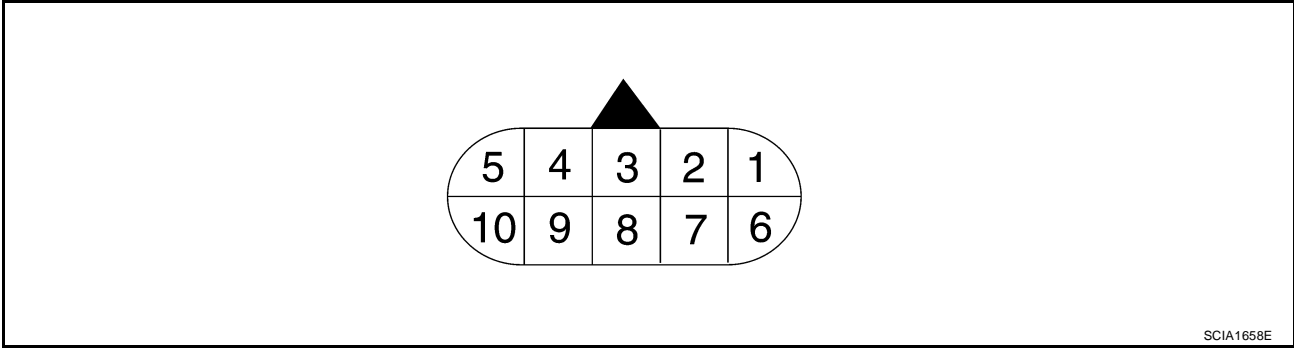

UCS0042F



SCIA1658E

### TCM INSPECTION TABLE

Data are reference value and are measured between each terminal and ground.

Terminal No.	Wire color	Item	Condition	Data (Approx.)	
1	R/B	Power supply (Memory back-up)	Always	Battery voltage	
2	R/B	Power supply (Memory back-up)	Always	Battery voltage	
3	L	CAN-H	-	-	
4	V	K-line (CONSULT-II signal)	The terminal is connected to the data link connector for CONSULT-II.	-	
5	B	Ground	Always	0V	
6	W/G	Power supply		-	Battery voltage
				-	0V
7	LG	Back-up lamp relay		Selector lever in "R" position.	0V
				Selector lever in other positions.	Battery voltage
8	P	CAN-L	-	-	
9	R	Starter relay		Selector lever in "N", "P" positions.	Battery voltage
				Selector lever in other positions.	0V
10	B	Ground	Always	0V	

# TROUBLE DIAGNOSIS

## CONSULT-II Function (A/T) FUNCTION

UCS0042G

Diagnostic test mode	Function	Reference page
Self-diagnostic results	Self-diagnostic results can be read and erased quickly.	<a href="#">AT-89</a>
Data monitor	Input/Output data in the TCM can be read.	<a href="#">AT-92</a>
CAN diagnostic support monitor	The results of transmit/receive diagnosis of CAN communication can be read.	<a href="#">AT-87</a>
Function test	Conducted by CONSULT-II instead of a technician to determine whether each system is "OK" or "NG".	—
DTC work support	Select the operating condition to confirm Diagnosis Trouble Codes.	<a href="#">AT-95</a>
ECU part number	TCM part number can be read.	—

## CONSULT-II REFERENCE VALUE

### NOTICE:

- The CONSULT-II electrically displays shift timing and lock-up timing (that is, operation timing of each solenoid).  
Check for time difference between actual shift timing and the CONSULT-II display. If the difference is noticeable, mechanical parts (except solenoids, sensors, etc.) may be malfunctioning. Check mechanical parts using applicable diagnostic procedures.
- Shift schedule (which implies gear position) displayed on CONSULT-II and that indicated in Service Manual may differ slightly. This occurs because of the following reasons:
  - Actual shift schedule has more or less tolerance or allowance,
  - Shift schedule indicated in Service Manual refers to the point where shifts start, and
  - Gear position displayed on CONSULT-II indicates the point where shifts are completed.
- Display of solenoid valves on CONSULT-II changes at the start of shifting, while gear position is displayed upon completion of shifting (which is computed by TCM).

Item name	Condition	Display value (Approx.)
ATF TEMP SE 1	0°C (32° F) - 20°C (68°F) - 80°C (176°F)	3.3 - 2.7 - 0.9 V
ATF TEMP SE 2		3.3 - 2.5 - 0.7 V
TCC SOLENOID	When perform slip lock-up	0.2 - 0.4 A
	When perform lock-up	0.4 - 0.6 A
SLCT LVR POSI	Selector lever in "N", "P" positions.	N/P
	Selector lever in "R" position.	R
	Selector lever in "D" position.	D
	Selector lever in "3" position.	3
	Selector lever in "2" position.	2
VHCL/S SE-A/T	During driving	Approximately matches the speedometer reading.
	Engine running	Closely matches the tachometer reading.
ENGINE SPEED	During driving	0.2 - 0.6 A
LINE PRES SOL	During driving (lock-up ON)	Approximately matches the engine speed.
VHCL/S SE-MTR	During driving	Approximately matches the speedometer reading.
ATF PRES SW 1	Front brake engaged. Refer to <a href="#">AT-21</a>	ON
	Front brake disengaged. Refer to <a href="#">AT-21</a>	OFF
ATF PRES SW 2	Low coast brake engaged. Refer to <a href="#">AT-21</a>	ON
	Low coast brake disengaged. Refer to <a href="#">AT-21</a>	OFF

## TROUBLE DIAGNOSIS

Item name	Condition	Display value (Approx.)
ATF PRES SW 3	Input clutch engaged. Refer to <a href="#">AT-21</a>	ON
	Input clutch disengaged. Refer to <a href="#">AT-21</a>	OFF
ATF PRES SW 5	Direct clutch engaged. Refer to <a href="#">AT-21</a>	ON
	Direct clutch disengaged. Refer to <a href="#">AT-21</a>	OFF
ATF PRES SW 6	High and low reverse clutch engaged. Refer to <a href="#">AT-21</a>	ON
	High and low reverse clutch disengaged. Refer to <a href="#">AT-21</a>	OFF
I/C SOLENOID	Input clutch disengaged. Refer to <a href="#">AT-21</a>	0.6 - 0.8 A
	Input clutch engaged. Refer to <a href="#">AT-21</a>	0 - 0.05 A
FR/B SOLENOID	Front brake engaged. Refer to <a href="#">AT-21</a>	0.6 - 0.8 A
	Front brake disengaged. Refer to <a href="#">AT-21</a>	0 - 0.05 A
D/C SOLENOID	Direct clutch disengaged. Refer to <a href="#">AT-21</a>	0.6 - 0.8 A
	Direct clutch engaged. Refer to <a href="#">AT-21</a>	0 - 0.05 A
HLR/C SOL	High and low reverse clutch disengaged. Refer to <a href="#">AT-21</a>	0.6 - 0.8 A
	High and low reverse clutch engaged. Refer to <a href="#">AT-21</a>	0 - 0.05 A
ON OFF SOL	Low coast brake engaged. Refer to <a href="#">AT-21</a>	ON
	Low coast brake disengaged. Refer to <a href="#">AT-21</a>	OFF
STARTER RELAY	Selector lever in "N", "P" positions.	ON
	Selector lever in other position.	OFF
ACCELE POSI	Released accelerator pedal.	0.0/8
	Fully depressed accelerator pedal.	8/8
CLSD THL POS	Released accelerator pedal.	ON
	Fully depressed accelerator pedal.	OFF
W/O THL POS	Fully depressed accelerator pedal.	ON
	Released accelerator pedal.	OFF
OD CONT SW	Releasing overdrive control switch	OFF
	Holding overdrive control switch	ON
BRAKE SW	Depressed brake pedal.	ON
	Released brake pedal.	OFF



# TROUBLE DIAGNOSIS

## CONSULT-II START PROCEDURE

Refer to [GI-38, "CONSULT-II Start Procedure"](#) .

## SELF-DIAGNOSTIC RESULT MODE

### Operation Procedure

After performing [AT-89, "SELF-DIAGNOSTIC RESULT MODE"](#) , place check marks for results on the [AT-47, "DIAGNOSTIC WORKSHEET"](#) . Reference pages are provided following the items.

1. Touch "SELF-DIAG RESULTS" on "SELECT DIAG MODE" screen.  
Display shows malfunction experienced since the last erasing operation.

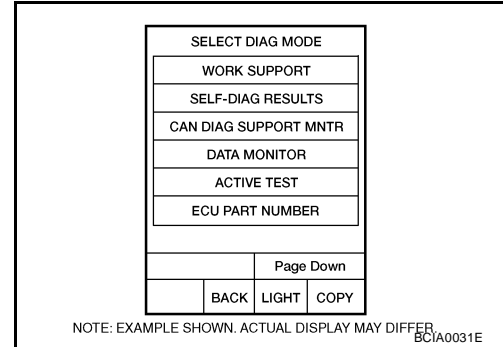

### Display Items List

X: Applicable, —: Not applicable

Items (CONSULT-II screen terms)	Malfunction is detected when...	TCM self-diagnosis	OBD-II (DTC)	Reference page
		"A/T" with CONSULT-II	MIL indicator lamp*1, "ENGINE" with CONSULT-II or GST	
CAN COMM CIRCUIT	<ul style="list-style-type: none"> <li>When TCM is not transmitting or receiving CAN communication signal for 2 seconds or more.</li> </ul>	U1000	U1000	<a href="#">AT-98</a>
STARTER RELAY/ CIRC	<ul style="list-style-type: none"> <li>If this signal is ON other than in "P" or "N" position, this is judged to be a malfunction. (And if it is OFF in "P" or "N" position, this too is judged to be a malfunction.)</li> </ul>	P0615	—	<a href="#">AT-101</a>
TCM	<ul style="list-style-type: none"> <li>TCM is malfunctioning.</li> </ul>	P0700	P0700	<a href="#">AT-105</a>
PNP SW/CIRC	<ul style="list-style-type: none"> <li>PNP switch 1-4 signals input with impossible pattern</li> <li>"P" position is detected from "N" position without any other position being detected in between.</li> </ul>	P0705	P0705	<a href="#">AT-106</a>
TURBINE REV S/CIRC	<ul style="list-style-type: none"> <li>TCM does not receive the proper voltage signal from the sensor.</li> <li>TCM detects an irregularity only at position of 4th gear for turbine revolution sensor 2.</li> </ul>	P0717	P0717	<a href="#">AT-110</a>
VEH SPD SEN/CIR AT (Revolution sensor)	<ul style="list-style-type: none"> <li>Signal from vehicle speed sensor A/T (Revolution sensor) not input due to cut line or the like</li> <li>Unexpected signal input during running</li> <li>After ignition switch is turned ON, unexpected signal input from vehicle speed sensor MTR before the vehicle starts moving</li> </ul>	P0720	P0720	<a href="#">AT-112</a>
ENGINE SPEED SIG	<ul style="list-style-type: none"> <li>TCM does not receive the CAN communication signal from the ECM.</li> </ul>	P0725	—	<a href="#">AT-117</a>
TCC SOLENOID/CIRC	<ul style="list-style-type: none"> <li>Normal voltage not applied to solenoid due to cut line, short, or the like</li> </ul>	P0740	P0740	<a href="#">AT-119</a>
A/T TCC S/V FNCTN	<ul style="list-style-type: none"> <li>A/T cannot perform lock-up even if electrical circuit is good.</li> <li>TCM detects as irregular by comparing difference value with slip rotation.</li> </ul>	P0744	P0744*2	<a href="#">AT-121</a>

## TROUBLE DIAGNOSIS

Items (CONSULT-II screen terms)	Malfunction is detected when...	TCM self-diagnosis	OBD-II (DTC)	Reference page
		"A/T" with CONSULT-II	MIL indicator lamp*1, "ENGINE" with CONSULT-II or GST	
L/PRESS SOL/CIRC	<ul style="list-style-type: none"> <li>Normal voltage not applied to solenoid due to cut line, short, or the like</li> <li>TCM detects as irregular by comparing target value with monitor value.</li> </ul>	P0745	P0745	<a href="#">AT-123</a>
TP SEN/CIRC A/T	<ul style="list-style-type: none"> <li>TCM does not receive the proper accelerator pedal position signals (input by CAN communication) from ECM.</li> </ul>	P1705	—	<a href="#">AT-125</a>
ATF TEMP SEN/CIRC	<ul style="list-style-type: none"> <li>During running, the ATF temperature sensor signal voltage is excessively high or low</li> </ul>	P1710	P0710	<a href="#">AT-128</a>
TURBINE REV S/CIRC	<ul style="list-style-type: none"> <li>TCM does not receive the proper voltage signal from the sensor.</li> <li>TCM detects an irregularity only at position of 4th gear for turbine revolution sensor 2.</li> </ul>	P1716	P1716	<a href="#">AT-110</a>
VEH SPD SE/CIR-MTR	<ul style="list-style-type: none"> <li>Signal (CAN communication) from vehicle speed sensor MTR not input due to cut line or the like</li> <li>Unexpected signal input during running</li> </ul>	P1721	—	<a href="#">AT-133</a>
A/T INTERLOCK	<ul style="list-style-type: none"> <li>Except during shift change, the gear position and ATF pressure switch states are monitored and comparative judgement made.</li> </ul>	P1730	P1730	<a href="#">AT-135</a>
A/T 1ST E/BRAKING	<ul style="list-style-type: none"> <li>Each ATF pressure switch and solenoid current is monitored and if a pattern is detected having engine braking 1st gear other than in the "1" position, a malfunction is detected.</li> </ul>	P1731	—	<a href="#">AT-138</a>
I/C SOLENOID/CIRC	<ul style="list-style-type: none"> <li>Normal voltage not applied to solenoid due to functional malfunction, cut line, short, or the like</li> <li>TCM detects as irregular by comparing target value with monitor value.</li> </ul>	P1752	P1752	<a href="#">AT-140</a>
I/C SOLENOID FNCTN	<ul style="list-style-type: none"> <li>TCM detects that actual gear ratio is irregular, and relation between gear position and condition of ATF pressure switch 3 is irregular during depressing accelerator pedal. (Other than during shift change)</li> <li>TCM detects that relation between gear position and condition of ATF pressure switch 3 is irregular during releasing accelerator pedal. (Other than during shift change)</li> </ul>	P1754	P1754*2	<a href="#">AT-142</a>
FR/B SOLENOID/CIRC	<ul style="list-style-type: none"> <li>Normal voltage not applied to solenoid due to functional malfunction, cut line, short, or the like</li> <li>TCM detects as irregular by comparing target value with monitor value.</li> </ul>	P1757	P1757	<a href="#">AT-144</a>
FR/B SOLENOID FNCT	<ul style="list-style-type: none"> <li>TCM detects that actual gear ratio is irregular, and relation between gear position and condition of ATF pressure switch 1 is irregular during depressing accelerator pedal. (Other than during shift change)</li> <li>TCM detects that relation between gear position and condition of ATF pressure switch 1 is irregular during releasing accelerator pedal. (Other than during shift change)</li> </ul>	P1759	P1759*2	<a href="#">AT-146</a>
D/C SOLENOID/CIRC	<ul style="list-style-type: none"> <li>Normal voltage not applied to solenoid due to cut line, short, or the like</li> <li>TCM detects as irregular by comparing target value with monitor value.</li> </ul>	P1762	P1762	<a href="#">AT-148</a>

# TROUBLE DIAGNOSIS

Items (CONSULT-II screen terms)	Malfunction is detected when...	TCM self-diagnosis	OBD-II (DTC)	Reference page	
		"A/T" with CONSULT-II	MIL indicator lamp*1, "ENGINE" with CONSULT-II or GST		
D/C SOLENOID FNCTN	<ul style="list-style-type: none"> <li>● TCM detects that actual gear ratio is irregular, and relation between gear position and condition of ATF pressure switch 5 is irregular during depressing accelerator pedal. (Other than during shift change)</li> <li>● TCM detects that relation between gear position and condition of ATF pressure switch 5 is irregular during releasing accelerator pedal. (Other than during shift change)</li> </ul>	P1764	P1764*2	<a href="#">AT-150</a>	AT
HLR/C SOL/CIRC	<ul style="list-style-type: none"> <li>● Normal voltage not applied to solenoid due to functional malfunction, cut line, short, or the like</li> <li>● TCM detects as irregular by comparing target value with monitor value.</li> </ul>	P1767	P1767	<a href="#">AT-152</a>	D
HLR/C SOL FNCTN	<ul style="list-style-type: none"> <li>● TCM detects that actual gear ratio is irregular, and relation between gear position and condition of ATF pressure switch 6 is irregular during depressing accelerator pedal. (Other than during shift change)</li> <li>● TCM detects that relation between gear position and condition of ATF pressure switch 6 is irregular during releasing accelerator pedal. (Other than during shift change)</li> </ul>	P1769	P1769*2	<a href="#">AT-154</a>	E
LC/B SOLENOID/CIRC	<ul style="list-style-type: none"> <li>● Normal voltage not applied to solenoid due to functional malfunction, cut line, short, or the like</li> </ul>	P1772	P1772	<a href="#">AT-156</a>	F
LC/B SOLENOID FNCT	<ul style="list-style-type: none"> <li>● TCM detects an improper voltage drop when it tries to operate the solenoid valve.</li> <li>● Condition of ATF pressure switch 2 is different from monitor value, and relation between gear position and actual gear ratio is irregular.</li> </ul>	P1774	P1774*2	<a href="#">AT-158</a>	G
ATF PRES SW 1/CIRC	<ul style="list-style-type: none"> <li>● TCM detects that actual gear ratio is normal, and relation between gear position and condition of ATF pressure switch 1 is irregular during depressing accelerator pedal. (Other than during shift change)</li> </ul>	P1841	—	<a href="#">AT-160</a>	H
ATF PRES SW 3/CIRC	<ul style="list-style-type: none"> <li>● TCM detects that actual gear ratio is normal, and relation between gear position and condition of ATF pressure switch 3 is irregular during depressing accelerator pedal. (Other than during shift change)</li> </ul>	P1843	—	<a href="#">AT-162</a>	I
ATF PRES SW 5/CIRC	<ul style="list-style-type: none"> <li>● TCM detects that actual gear ratio is normal, and relation between gear position and condition of ATF pressure switch 5 is irregular during depressing accelerator pedal. (Other than during shift change)</li> </ul>	P1845	—	<a href="#">AT-164</a>	J
ATF PRES SW 6/CIRC	<ul style="list-style-type: none"> <li>● TCM detects that actual gear ratio is normal, and relation between gear position and condition of ATF pressure switch 6 is irregular during depressing accelerator pedal. (Other than during shift change)</li> </ul>	P1846	—	<a href="#">AT-166</a>	K
NO DTC IS DETECTED FURTHER TESTING MAY BE REQUIRED	<ul style="list-style-type: none"> <li>● No NG item has been detected.</li> </ul>	X	X	—	L

\*1: Refer to [AT-42, "Malfunction Indicator Lamp \(MIL\)"](#).

\*2: These malfunctions cannot be displayed MIL if another malfunction is assigned to MIL.

# TROUBLE DIAGNOSIS

## DATA MONITOR MODE

### Display Items List

X: Standard, —: Not applicable, ▼: Option

Monitored item (Unit)	Monitor Item Selection			Remarks
	ECU INPUT SIGNALS	MAIN SIGNALS	SELECTION FROM MENU	
VHCL/S SE-A/T (km/h)	X	X	▼	Revolution sensor
VHCL/S SE-MTR (km/h)	X	—	▼	
ACCELE POSI (0.0/8)	X	—	▼	Accelerator pedal position signal
THROTTLE POSI (0.0/8)	X	X	▼	Degree of opening for accelerator recognized by the TCM For fail-safe operation, the specific value used for control is displayed.
CLSD THL POS (ON-OFF display)	X	—	▼	Signal input with CAN communications
W/O THL POS (ON-OFF display)	X	—	▼	
BRAKE SW (ON-OFF display)	X	—	▼	Stop lamp switch
GEAR	—	X	▼	Gear position recognized by the TCM updated after gear-shifting
ENGINE SPEED (rpm)	X	X	▼	
TURBINE REV (rpm)	X	X	▼	
OUTPUT REV (rpm)	X	X	▼	
GEAR RATIO	—	X	▼	
TC SLIP SPEED (rpm)	—	X	▼	Difference between engine speed and torque converter input shaft speed
F SUN GR REV (rpm)	—	—	▼	
F CARR GR REV (rpm)	—	—	▼	
ATF TEMP SE 1 (V)	X	—	▼	
ATF TEMP SE 2 (V)	X	—	▼	
ATF TEMP 1 (°C)	—	X	▼	
ATF TEMP 2 (°C)	—	X	▼	
BATTERY VOLT (V)	X	—	▼	
ATF PRES SW 1 (ON-OFF display)	X	X	▼	(for FR/B solenoid)
ATF PRES SW 2 (ON-OFF display)	X	X	▼	(for LC/B solenoid)
ATF PRES SW 3 (ON-OFF display)	X	X	▼	(for I/C solenoid)
ATF PRES SW 5 (ON-OFF display)	X	X	▼	(for D/C solenoid)
ATF PRES SW 6 (ON-OFF display)	X	X	▼	(for HLR/C solenoid)
PNP SW 1 (ON-OFF display)	X	—	▼	
PNP SW 2 (ON-OFF display)	X	—	▼	
PNP SW 3 (ON-OFF display)	X	—	▼	
PNP SW 4 (ON-OFF display)	X	—	▼	
1 POSITION SW (ON-OFF display)	X	—	▼	1st position switch

# TROUBLE DIAGNOSIS

Monitored item (Unit)	Monitor Item Selection			Remarks
	ECU INPUT SIGNALS	MAIN SIGNALS	SELECTION FROM MENU	
SLCT LVR POSI	—	X	▼	Selector lever position is recognized by the TCM. For fail-safe operation, the specific value used for control is displayed.
OD CONT SW (ON-OFF display)	X	—	▼	Not mounted but displayed.
POWERSHIFT SW (ON-OFF display)	X	—	▼	
HOLD SW (ON-OFF display)	X	—	▼	
MANU MODE SW (ON-OFF display)	X	—	▼	
NON M-MODE SW (ON-OFF display)	X	—	▼	
UP SW LEVER (ON-OFF display)	X	—	▼	
DOWN SW LEVER (ON-OFF display)	X	—	▼	
SFT UP ST SW (ON-OFF display)	—	—	▼	
SFT DWN ST SW (ON-OFF display)	—	—	▼	
ASCD-OD CUT (ON-OFF display)	—	—	▼	
ASCD-CRUISE (ON-OFF display)	—	—	▼	
ABS SIGNAL (ON-OFF display)	—	—	▼	
ACC OD CUT (ON-OFF display)	—	—	▼	Not mounted but displayed.
ACC SIGNAL (ON-OFF display)	—	—	▼	
TCS GR/P KEEP (ON-OFF display)	—	—	▼	
TCS SIGNAL 2 (ON-OFF display)	—	—	▼	
TCS SIGNAL 1 (ON-OFF display)	—	—	▼	
TCC SOLENOID (A)	—	X	▼	
LINE PRES SOL (A)	—	X	▼	
I/C SOLENOID (A)	—	X	▼	
FR/B SOLENOID (A)	—	X	▼	
D/C SOLENOID (A)	—	X	▼	
HLR/C SOL (A)	—	X	▼	LC/B solenoid
ON OFF SOL (ON-OFF display)	—	—	▼	
TCC SOL MON (A)	—	—	▼	
L/P SOL MON (A)	—	—	▼	
I/C SOL MON (A)	—	—	▼	
FR/B SOL MON (A)	—	—	▼	
D/C SOL MON (A)	—	—	▼	
HLR/C SOL MON (A)	—	—	▼	
ONOFF SOL MON (ON-OFF display)	—	—	▼	
P POSI IND (ON-OFF display)	—	—	▼	

# TROUBLE DIAGNOSIS

Monitored item (Unit)	Monitor Item Selection			Remarks
	ECU INPUT SIGNALS	MAIN SIGNALS	SELECTION FROM MENU	
R POSI IND (ON-OFF display)	—	—	▼	
N POSI IND (ON-OFF display)	—	—	▼	
D POSI IND (ON-OFF display)	—	—	▼	
4TH POSI IND (ON-OFF display)	—	—	▼	
3RD POSI IND (ON-OFF display)	—	—	▼	
2ND POSI IND (ON-OFF display)	—	—	▼	
1ST POSI IND (ON-OFF display)	—	—	▼	
MANU MODE IND (ON-OFF display)	—	—	▼	Not mounted but displayed.
POWER M LAMP (ON-OFF display)	—	—	▼	
F-SAFE IND/L (ON-OFF display)	—	—	▼	
ATF WARN LAMP (ON-OFF display)	—	—	▼	
BACK-UP LAMP (ON-OFF display)	—	—	▼	
STARTER RELAY (ON-OFF display)	—	—	▼	
PNP SW3 MON (ON-OFF display)	—	—	▼	"OFF" is always indicated
C/V CLB ID1	—	—	▼	
C/V CLB ID2	—	—	▼	
C/V CLB ID3	—	—	▼	
UNIT CLB ID1	—	—	▼	
UNIT CLB ID2	—	—	▼	
UNIT CLB ID3	—	—	▼	
TRGT GR RATIO	—	—	▼	
TRGT PRES TCC (kPa)	—	—	▼	
TRGT PRES L/P (kPa)	—	—	▼	
TRGT PRES I/C (kPa)	—	—	▼	
TRGT PRE FR/B (kPa)	—	—	▼	
TRGT PRES D/C (kPa)	—	—	▼	
TRG PRE HLR/C (kPa)	—	—	▼	
SHIFT PATTERN	—	—	▼	
DRV CST JUDGE	—	—	▼	
START RLY MON	—	—	▼	
NEXT GR POSI	—	—	▼	
SHIFT MODE	—	—	▼	
MANU GR POSI	—	—	▼	
VEHICLE SPEED (km/h)	—	X	▼	Vehicle speed recognized by the TCM.

# TROUBLE DIAGNOSIS

Monitored item (Unit)	Monitor Item Selection			Remarks
	ECU INPUT SIGNALS	MAIN SIGNALS	SELECTION FROM MENU	
Voltage (V)	—	—	▼	Displays the value measured by the voltage probe.
Frequency (Hz)	—	—	▼	The value measured by the pulse probe is displayed.
DUTY-HI (high) (%)	—	—	▼	
DUTY-LOW (low) (%)	—	—	▼	
PLS WIDTH-HI (ms)	—	—	▼	
PLS WIDTH-LOW (ms)	—	—	▼	

## CAN DIAGNOSTIC SUPPORT MONITOR MODE

Refer to [AT-87, "CONSULT-II REFERENCE VALUE"](#) .

## DTC WORK SUPPORT MODE

### Display Items List

DTC work support item	Description	Check item
I/C SOL FUNCTN CHECK*	—	—
FR/B SOL FUNCTN CHECK*	—	—
D/C SOL FUNCTN CHECK*	—	—
HLR/C SOL FUNCTN CHECK*	—	—
LC/B SOL FUNCTN CHECK*	—	—
TCC SOL FUNCTN CHECK	Following items for "TCC solenoid function (lock-up) " can be confirmed. <ul style="list-style-type: none"> <li>● Self-diagnosis status (whether the diagnosis is being conducted or not)</li> <li>● Self-diagnosis result (OK or NG)</li> </ul>	<ul style="list-style-type: none"> <li>● TCC solenoid valve</li> <li>● Hydraulic control circuit</li> </ul>

\*: Do not use, but displayed.

# TROUBLE DIAGNOSIS

UCS0042H

## Diagnostic Procedure Without CONSULT-II



### OBD-II SELF-DIAGNOSTIC PROCEDURE (WITH GST)

Refer to [EC-738, "Generic Scan Tool \(GST\) Function"](#) .



### OBD-II SELF-DIAGNOSTIC PROCEDURE (NO TOOLS)

Refer to [EC-672, "Malfunction Indicator Lamp \(MIL\)"](#) .



### TCM SELF-DIAGNOSTIC PROCEDURE (NO TOOLS)

#### Description

When the ignition switch is switched "ON", the O/D OFF indicator lamp lights up for 2 seconds. As a method for locating the suspect circuit, when the self-diagnostics start signal is input, the memory for the malfunction location is output and the O/D OFF indicator lamp flashes to display the corresponding DTC.

#### Diagnostic Procedure

### 1. CHECK O/D OFF INDICATOR LAMP

1. Start the engine with selector lever in "P" position. Warm engine to normal operating temperature.
2. Turn ignition switch ON and OFF at least twice, then leave it in the OFF position.
3. Wait 10 seconds.
4. Turn ignition switch ON. (Do not start engine.)

Does O/D OFF indicator lamp come on for about 2 seconds?

YES >> GO TO 2.

NO >> GO TO [AT-178, "O/D OFF Indicator Lamp Does Not Come On"](#) .

### 2. JUDGEMENT PROCEDURE STEP 1

1. Turn ignition switch OFF.
2. Push shift lock release button.
3. Move selector lever from "P" to "D" position.
4. Release accelerator pedal. (Set the closed throttle position signal "ON".)
5. Depress brake pedal. (Stop lamp switch signal "ON".)
6. Turn ignition switch ON.
7. Wait 3 seconds.
8. Move the selector lever from "D" to "3" position.
9. Release brake pedal. (Stop lamp switch signal "OFF".)
10. Move the selector lever from "3" to "2" position.
11. Depress brake pedal. (Stop lamp switch signal "ON".)
12. Depress accelerator pedal fully and release it.

>> GO TO 3.

### 3. CHECK SELF-DIAGNOSIS CODE

Check O/D OFF indicator lamp.

Refer to [AT-97, "Judgement Self-diagnosis Code"](#) .

If the system does not go into self-diagnostics. Refer to [AT-106, "DTC P0705 PARK/NEUTRAL POSITION SWITCH"](#) , [AT-172, "CLOSED THROTTLE POSITION AND WIDE OPEN THROTTLE POSITION CIRCUIT"](#) , [AT-173, "BRAKE SIGNAL CIRCUIT"](#) .

>> DIAGNOSIS END



# TROUBLE DIAGNOSIS

## Judgement Self-diagnosis Code

If there is a malfunction, the lamp lights up for the time corresponding to the suspect circuit.

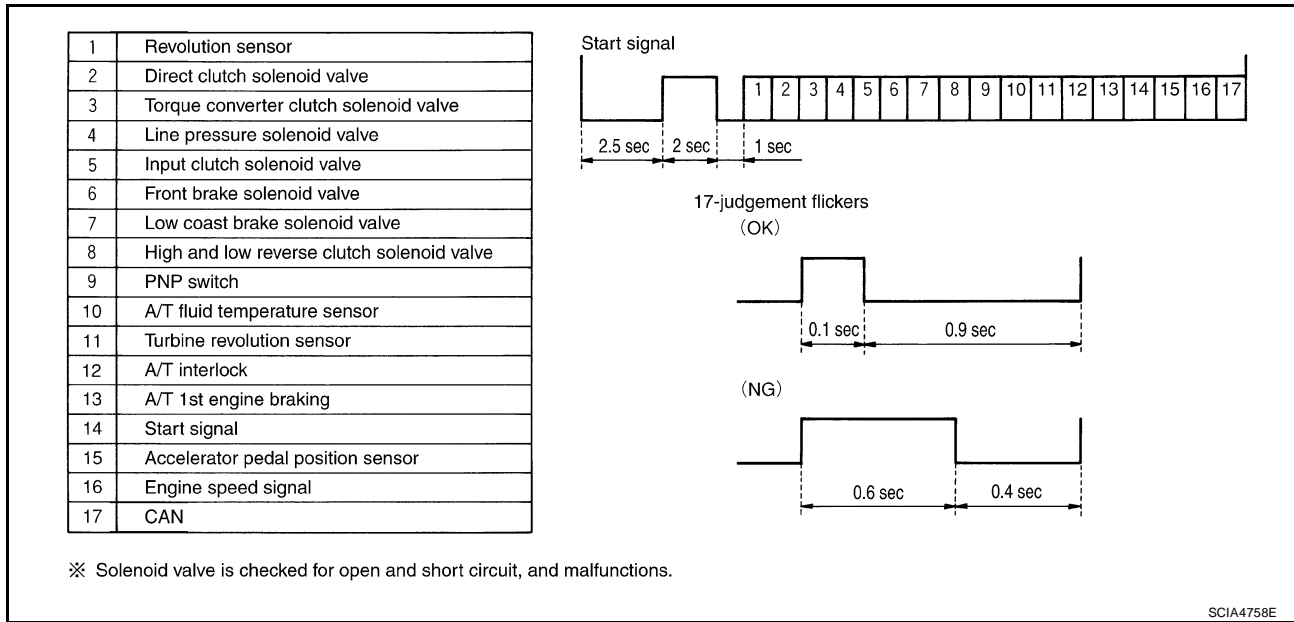

## Erase Self-diagnosis

- In order to make it easier to find the cause of hard-to-duplicate malfunctions, malfunction information is stored into the control unit as necessary during use by the user. This memory is not erased no matter how many times the ignition switch is turned ON and OFF.
- However, this information is erased by turning ignition switch OFF after executing self-diagnostics or by erasing the memory using the CONSULT-II.

# DTC U1000 CAN COMMUNICATION LINE

## DTC U1000 CAN COMMUNICATION LINE

PF2:23710

### Description

UCS0042I

CAN (Controller Area Network) is a serial communication line for real time application. It is an on-vehicle multiplex communication line with high data communication speed and excellent malfunction detection ability. Many electronic control units are equipped onto a vehicle, and each control unit shares information and links with other control units during operation (not independent). In CAN communication, control units are connected with 2 communication lines (CAN H line, CAN L line) allowing a high rate of information transmission with less wiring. Each control unit transmits/receives data but selectively reads required data only.

### On Board Diagnosis Logic

UCS0042J

- This is an OBD-II self-diagnostic item.
- Diagnostic trouble code "U1000 CAN COMM CIRCUIT" with CONSULT-II or 17th judgement flicker without CONSULT-II is detected when TCM cannot communicate to other control units.

### Possible Cause

UCS0042K

Harness or connectors  
(CAN communication line is open or shorted.)

### DTC Confirmation Procedure

UCS0042L

#### NOTE:

If "DTC Confirmation Procedure" has been previously performed, always turn ignition switch "OFF" and wait at least 10 seconds before performing the next test.

After the repair, perform the following procedure to confirm the malfunction is eliminated.

#### ④ WITH CONSULT-II

1. Turn ignition switch "ON". (Do not start engine.)
2. Select "DATA MONITOR" mode for "ENGINE" with CONSULT-II.
3. Start engine and wait for at least 6 seconds.
4. If DTC is detected, go to [AT-100, "Diagnostic Procedure"](#).

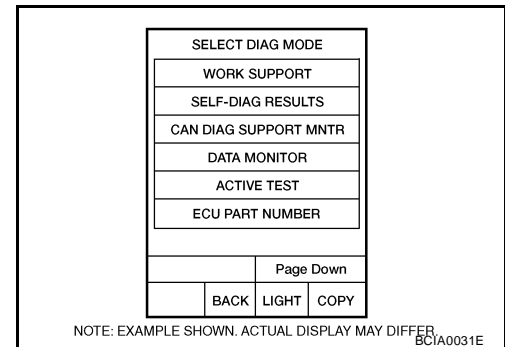

#### ④ WITH GST



Follow the procedure "WITH CONSULT-II".

# DTC U1000 CAN COMMUNICATION LINE

## Wiring Diagram — AT — CAN

UCS0042M

### AT-CAN-01

-  : DETECTABLE LINE FOR DTC
-  : NON-DETECTABLE LINE FOR DTC
-  : DATA LINE

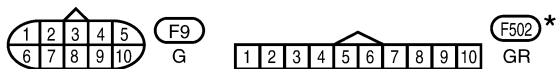
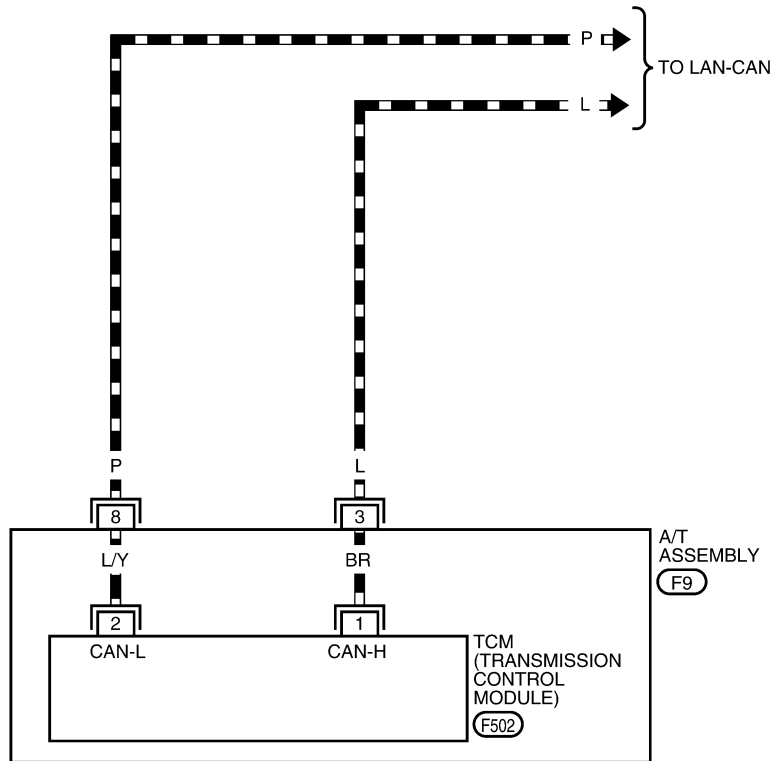

\*: THIS CONNECTOR IS NOT SHOWN IN "HARNESS LAYOUT" OF PG SECTION.

BCWA0320E

# DTC U1000 CAN COMMUNICATION LINE

## TCM INPUT/OUTPUT SIGNAL REFERENCE VALUES

Refer to [AT-86, "TCM Input/Output Signal Reference Values"](#) .

## Diagnostic Procedure

UCS0042N

### 1. CHECK CAN COMMUNICATION CIRCUIT

#### Ⓟ With CONSULT-II

1. Turn ignition switch "ON" and start engine.
2. Select "SELF-DIAG RESULTS" mode for "A/T" with CONSULT-II.

Is any malfunction of the "CAN COMM CIRCUIT" indicated?

- YES >> Print out CONSULT-II screen, GO TO LAN section.  
Refer to [LAN-48, "CAN System Specification Chart"](#) .
- NO >> **INSPECTION END**

SELF-DIAG RESULTS			
DTC RESULTS			
CAN COMM CIRCUIT [U1000]			
ERASE		PRINT	
MODE	BACK	LIGHT	COPY

PCIA0061E

# DTC P0615 START SIGNAL CIRCUIT

## DTC P0615 START SIGNAL CIRCUIT

PF:25230

### Description

UCS00420

- TCM prohibits cranking other than at "P" or "N" position.

### CONSULT-II Reference Value

UCS0042P

Item name	Condition	Display value
STARTER RELAY	Selector lever in "N", "P" positions.	ON
	Selector lever in other position.	OFF

### On Board Diagnosis Logic

UCS0042Q

- This is not an OBD-II self-diagnostic item.
- Diagnostic trouble code "P0615 STARTER RELAY/CIRC" with CONSULT-II or 14th judgement flicker without CONSULT-II is detected when park/neutral (PNP) relay (starter relay) is switched "ON" other than at "P" or "N" position. (Or when switched "OFF" at "P" or "N" position).

### Possible Cause

UCS0042R

- Harness or connectors  
[The park/neutral position (PNP) relay (starter relay) and TCM circuit is open or shorted.]
- Park/neutral position (PNP) relay (starter relay)

### DTC Confirmation Procedure

UCS0042S

#### NOTE:

If "DTC Confirmation Procedure" has been previously performed, always turn ignition switch "OFF" and wait at least 10 seconds before performing the next test.

After the repair, perform the following procedure to confirm the malfunction is eliminated.

#### WITH CONSULT-II

- Turn ignition switch "ON". (Do not start engine.)
- Select "DATA MONITOR" mode for "A/T" with CONSULT-II.
- Start engine.
- Drive vehicle for at least 2 consecutive seconds.
- If DTC is detected, go to [AT-103, "Diagnostic Procedure"](#).

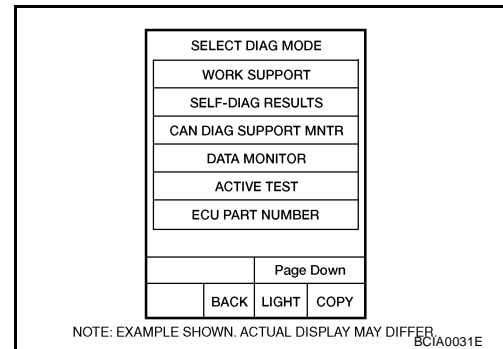

# DTC P0615 START SIGNAL CIRCUIT

## Wiring Diagram — AT — STSIG

UCS0042T

### AT-STSIG-01

- : DETECTABLE LINE FOR DTC
- : NON-DETECTABLE LINE FOR DTC
- ▬** : DATA LINE
- ZV** : WITH VQ40DE
- QR** : WITH QR25DE

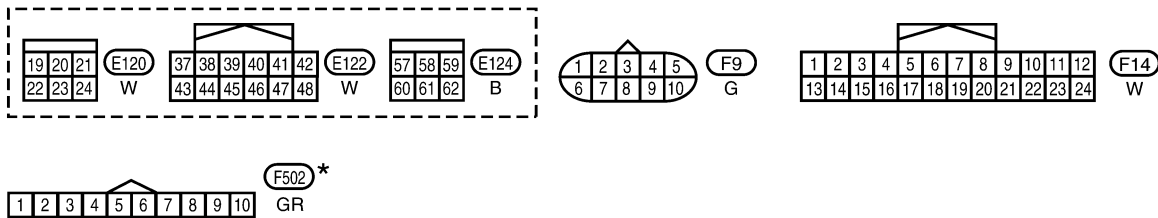
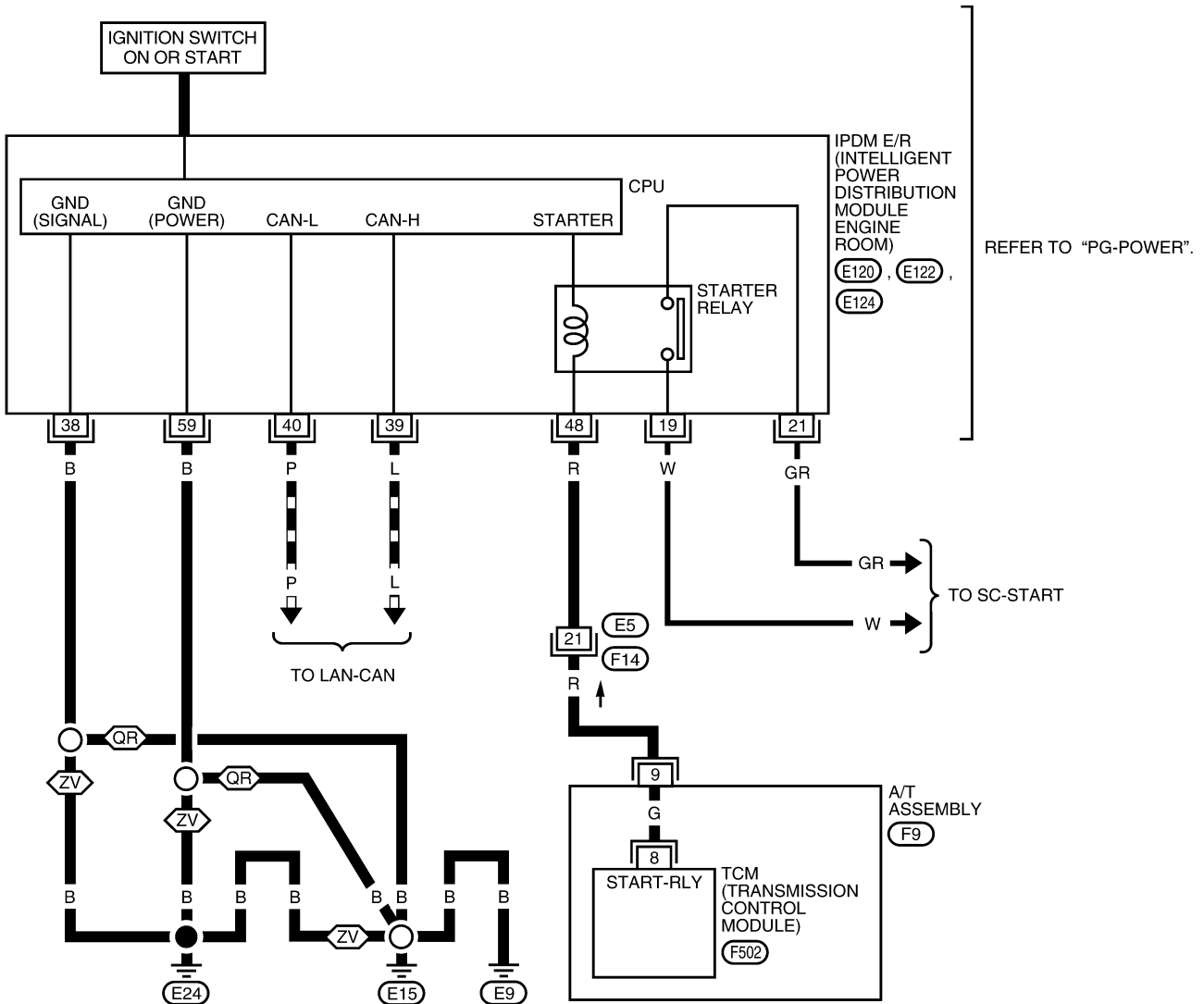

\* : THIS CONNECTOR IS NOT SHOWN IN "HARNESS LAYOUT" OF PG SECTION.

BCWA0401E

# DTC P0615 START SIGNAL CIRCUIT

## TCM INPUT/OUTPUT SIGNAL REFERENCE VALUES

Refer to [AT-86, "TCM Input/Output Signal Reference Values"](#).

## Diagnostic Procedure

UCS0042U

### 1. CHECK STARTER RELAY

#### ④ With CONSULT-II

- Turn ignition switch ON. (Do not start engine.)
- Select "SELECTION FROM MENU" in "DATA MONITOR" mode for "A/T" with CONSULT-II and check monitor "STARTER RELAY" ON/OFF.

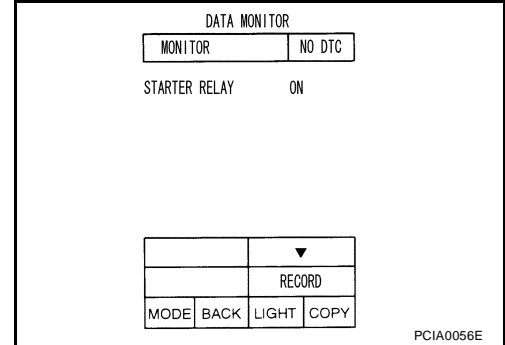

#### ⊗ Without CONSULT-II

- Turn ignition switch ON. (Do not start engine.)
- Check voltage between the IPDM E/R connector and ground.

Item	Connector	Terminal	Shift position	Voltage (Approx.)	
Starter relay	E122	48	Ground	"N" and "P"	Battery voltage
				"R" and "D"	0V

#### OK or NG

- OK >> GO TO 5.  
NG >> GO TO 2.

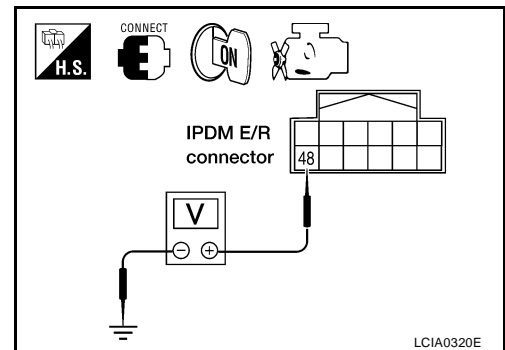

### 2. CHECK HARNESS BETWEEN A/T ASSEMBLY HARNESS CONNECTOR AND IPDM E/R CONNECTOR

- Turn ignition switch OFF.
- Disconnect A/T assembly harness connector and IPDM E/R connector.
- Check continuity between A/T assembly harness connector and IPDM E/R connector.

Item	Connector	Terminal	Continuity
A/T assembly harness connector	F9	9	Yes
IPDM E/R connector	E122	48	

- If OK, check harness for short to ground and short to power.
- Reinstall any part removed.

#### OK or NG

- OK >> GO TO 3.  
NG >> Repair open circuit or short to ground or short to power in harness or connectors.

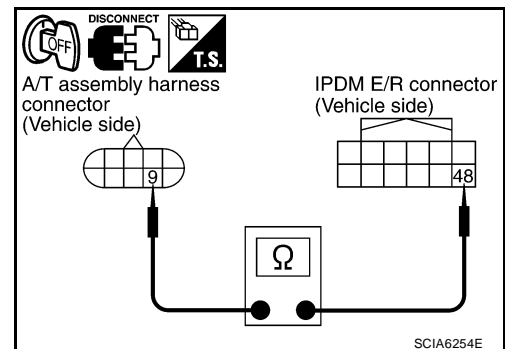

# DTC P0615 START SIGNAL CIRCUIT

## 3. CHECK TERMINAL CORD ASSEMBLY

1. Remove control valve with TCM. Refer to [AT-228, "Control Valve With TCM and A/T Fluid Temperature Sensor 2"](#) .
2. Disconnect A/T assembly harness connector and TCM connector.
3. Check continuity between A/T assembly harness connector terminal and TCM connector terminal.

Item	Connector	Terminal	Continuity
A/T assembly harness connector	F9	9	Yes
TCM connector	F502	8	

4. If OK, check harness for short to ground and short to power.
5. Reinstall any part removed.

OK or NG

OK >> GO TO 4.

NG >> Replace open circuit or short to ground and short to power in harness or connectors.

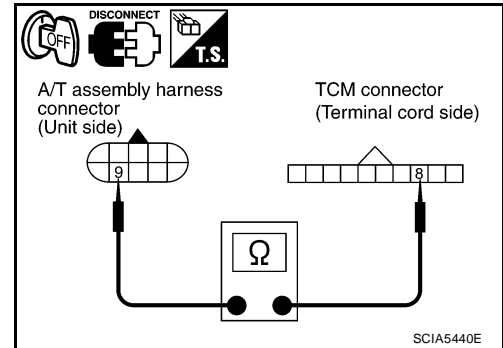

## 4. DETECT MALFUNCTIONING ITEM

Check the following.

- Starter relay, Refer to [SC-10, "STARTING SYSTEM"](#) .
- IPDM E/R, Refer to [PG-18, "IPDM E/R \(INTELLIGENT POWER DISTRIBUTION MODULE ENGINE ROOM\)"](#) .

OK or NG

OK >> Replace the control valve with TCM. Refer to [AT-228, "Control Valve With TCM and A/T Fluid Temperature Sensor 2"](#) .

NG >> Repair or replace damaged parts.

## 5. CHECK DTC

Perform [AT-101, "DTC Confirmation Procedure"](#) .

OK or NG

OK >> **INSPECTION END**

NG >> GO TO 2.



# DTC P0700 TCM

## DTC P0700 TCM

PF3:31036

### Description

UCS0042V

The TCM consists of a microcomputer and connectors for signal input and output and for power supply. The TCM controls the A/T.

### On Board Diagnosis Logic

UCS0042W

- This is an OBD-II self-diagnostic item.
- Diagnostic trouble code "P0700 TCM" with CONSULT-II is detected when the TCM is malfunctioning.

### Possible Cause

UCS0042X

TCM.

### DTC Confirmation Procedure

UCS0042Y

#### NOTE:

If "DTC Confirmation Procedure" has been previously performed, always turn ignition switch "OFF" and wait at least 10 seconds before performing the next test.

After the repair, perform the following procedure to confirm the malfunction is eliminated.

#### WITH CONSULT-II

1. Turn ignition switch "ON". (Do not start engine.)
2. Select "DATA MONITOR" mode for "A/T" with CONSULT-II.
3. Start engine.
4. Run engine for at least 2 consecutive seconds at idle speed.
5. If DTC is detected, go to [AT-105, "Diagnostic Procedure"](#).

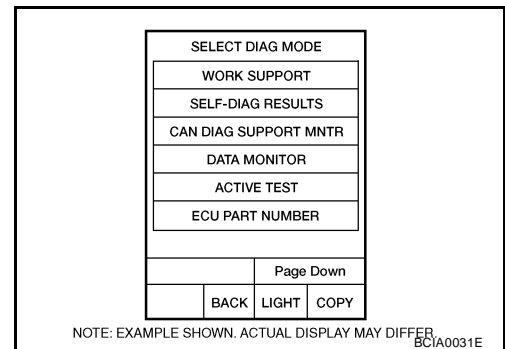

#### WITH GST

Follow the procedure "WITH CONSULT-II".

### Diagnostic Procedure

UCS0042Z

#### 1. CHECK DTC

##### With CONSULT-II

1. Turn ignition switch "ON". (Do not start engine.)
2. Select "SELF DIAG RESULTS" mode for "A/T" with CONSULT-II.
3. Touch "ERASE".
4. Turn ignition switch "OFF" and wait at least 10 seconds.
5. Perform [AT-105, "DTC Confirmation Procedure"](#).

Is the "TCM" displayed again?

YES >> Replace the control valve with TCM. Refer to [AT-228, "Control Valve With TCM and A/T Fluid Temperature Sensor 2"](#).

NO >> **INSPECTION END**

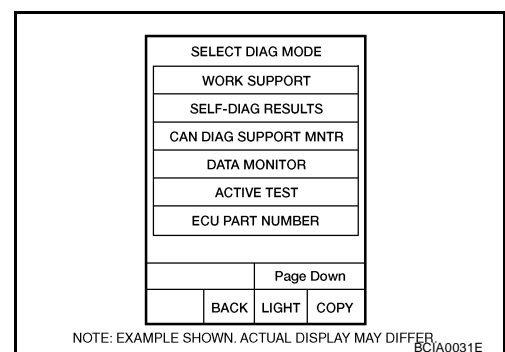

# DTC P0705 PARK/NEUTRAL POSITION SWITCH

## DTC P0705 PARK/NEUTRAL POSITION SWITCH

PF3:32006

### Description

UCS00430

- The park/neutral position (PNP) switch includes a transmission position switch.
- The transmission range switch detects the selector lever position and sends a signal to the TCM.

### CONSULT-II Reference Value

UCS00431

Item name	Condition	Display value
SLCTLVR POSI	Selector lever in "N","P" positions.	N/P
	Selector lever in "R" position.	R
	Selector lever in "D" position.	D
	Selector lever in "3" position.	3
	Selector lever in "2" position.	2
	Selector lever in "1" position.	1

### On Board Diagnosis Logic

UCS00432

- This is an OBD-II self-diagnostic item.
- Diagnostic trouble code "P0705 PNP SW/CIRC" with CONSULT-II or 9th judgement flicker without CONSULT-II is detected under the following conditions.
  - When TCM does not receive the correct voltage signal from the PNP switch 1, 2, 3, 4 based on the gear position.
  - When no other position but "P" position is detected from "N" positions.

### Possible Cause

UCS00433

- Harness or connectors  
[The park/neutral position (PNP) switch 1, 2, 3, 4 and TCM circuit is open or shorted.]
- Park/neutral position (PNP) switch 1, 2, 3, 4

### DTC Confirmation Procedure

UCS00434

#### CAUTION:

Always drive vehicle at a safe speed.

#### NOTE:

If "DTC Confirmation Procedure" has been previously performed, always turn ignition switch "OFF" and wait at least 10 seconds before performing the next test.

After the repair, perform the following procedure to confirm the malfunction is eliminated.

#### ① WITH CONSULT-II

1. Turn ignition switch "ON". (Do not start engine.)
2. Select "DATA MONITOR" mode for "A/T" with CONSULT-II.
3. Start engine.
4. Drive vehicle and maintain the following conditions for at least 2 consecutive seconds.  
**ACCELE POSI: More than 1.018V**
5. If DTC is detected, go to [AT-108, "Diagnostic Procedure"](#).

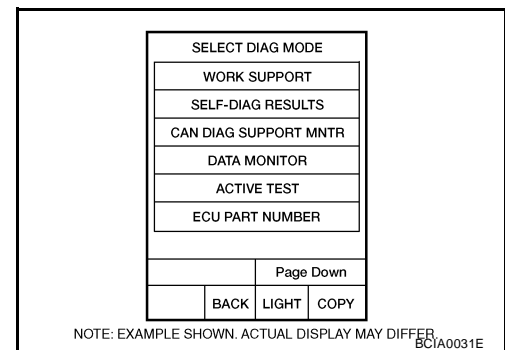

#### ② WITH GST

Follow the procedure "WITH CONSULT-II".

# DTC P0705 PARK/NEUTRAL POSITION SWITCH

## Wiring Diagram — AT — PNP/SW

UCS00435

### AT-PNP/SW-01

: DETECTABLE LINE FOR DTC  
 : NON-DETECTABLE LINE FOR DTC

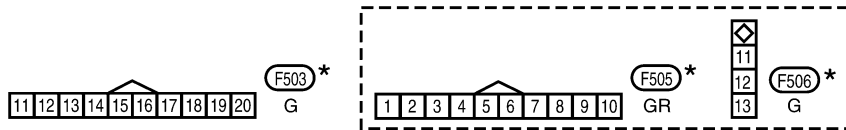
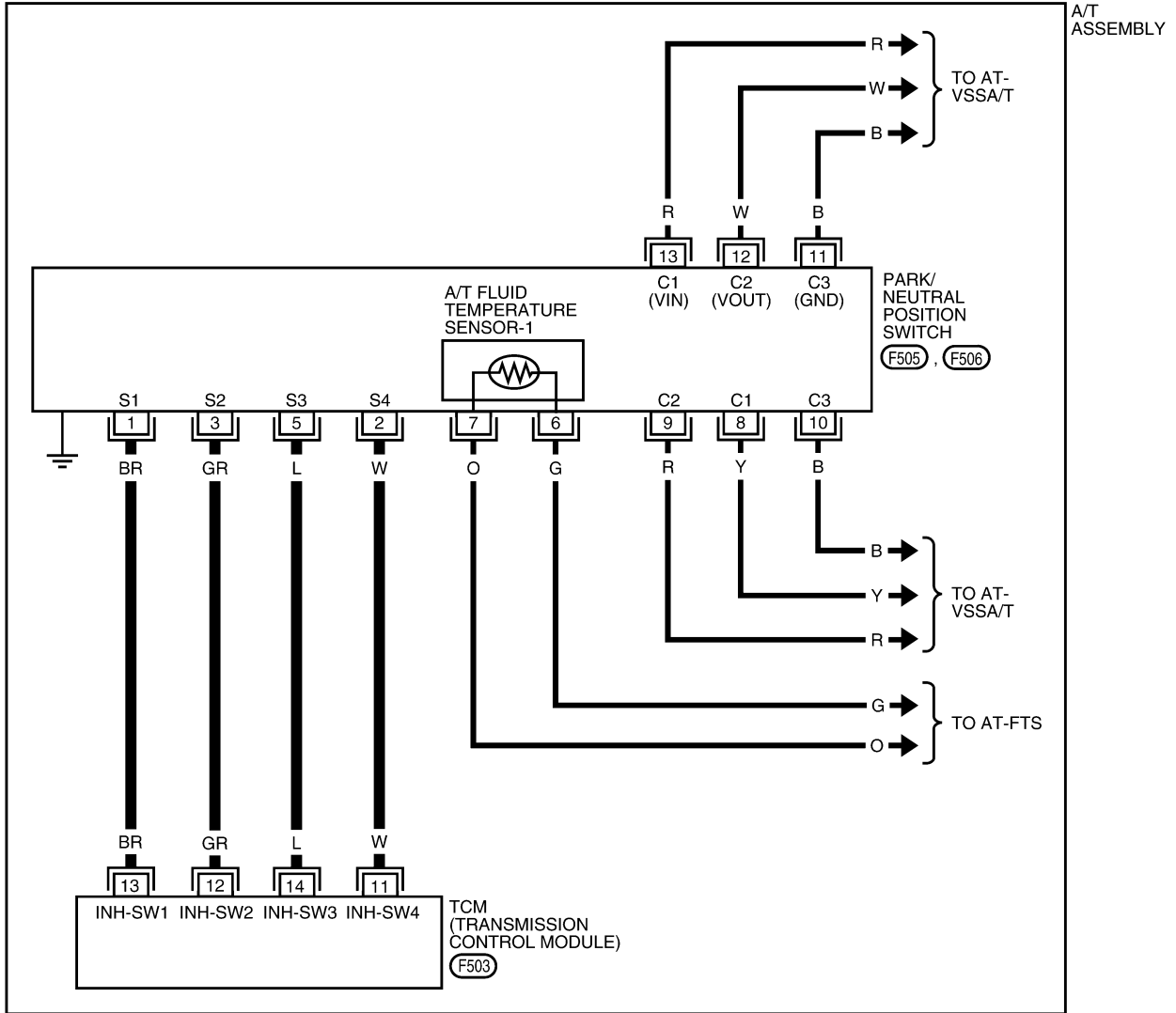

\*: THIS CONNECTOR IS NOT SHOWN IN "HARNESS LAYOUT" OF PG SECTION.

BCWA0581E

# DTC P0705 PARK/NEUTRAL POSITION SWITCH

UCS00436

## Diagnostic Procedure

### 1. CHECK PNP SW CIRCUIT

#### With CONSULT-II

1. Turn ignition switch ON. (Do not start engine.)
2. Select "SELECTION FROM MENU" in "DATA MONITOR" mode for "A/T" with CONSULT-II.
3. Check if correct selector lever position (N/P, R, D, 3, 2 or 1) is displayed as selector lever is moved into each position.

#### OK or NG

- OK >> GO TO 5.  
NG >> GO TO 2.

DATA MONITOR			
MONITOR		NO DTC	
ATF PRES SW 2	OFF		
ATF PRES SW 3	OFF		
ATF PRES SW 5	OFF		
ATF PRES SW 6	OFF		
SLCT LVR POSI	N·P		
△		▽	
RECORD			
MODE	BACK	LIGHT	COPY

PCIA0034E

### 2. CHECK TCM POWER SUPPLY AND GROUND CIRCUIT

Check TCM power supply and ground circuit. Refer to [AT-168, "MAIN POWER SUPPLY AND GROUND CIRCUIT"](#).

#### OK or NG

- OK >> GO TO 3.  
NG >> Repair or replace damaged parts.

### 3. DETECT MALFUNCTIONING ITEM

Check the following.

- A/T assembly harness connector pin terminals for damage or loose connection with harness connector.

#### OK or NG

- OK >> GO TO 4.  
NG >> Repair or replace damaged parts.

# DTC P0705 PARK/NEUTRAL POSITION SWITCH

## 4. CHECK SUB-HARNESS

1. Remove control valve with TCM. Refer to [AT-228, "Control Valve With TCM and A/T Fluid Temperature Sensor 2"](#) .
2. Disconnect park/neutral position switch connector and TCM connector.
3. Check continuity between park/neutral position switch connector terminals and TCM connector terminals.

Item	Connector	Terminal	Continuity
Park/neutral position switch connector	F505	1	Yes
TCM connector	F503	13	
Park/neutral position switch connector	F505	2	Yes
TCM connector	F503	11	
Park/neutral position switch connector	F505	3	Yes
TCM connector	F503	12	
Park/neutral position switch connector	F505	5	Yes
TCM connector	F503	14	

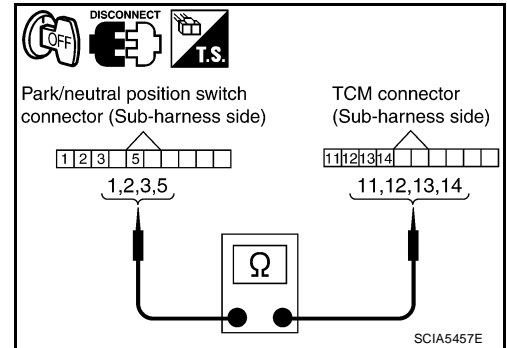

4. If OK, check harness for short to ground and short to power.
5. Reinstall any part removed.

### OK or NG

- OK >> Replace the control valve with TCM. Refer to [AT-228, "Control Valve With TCM and A/T Fluid Temperature Sensor 2"](#) .
- NG >> Replace open circuit or short to ground and short to power in harness or connectors.

## 5. CHECK DTC

Perform "DTC Confirmation Procedure".

- Refer to [AT-106, "DTC Confirmation Procedure"](#) .

### OK or NG

- OK >> **INSPECTION END**
- NG >> GO TO 2.

# DTC P0717 TURBINE REVOLUTION SENSOR

## DTC P0717 TURBINE REVOLUTION SENSOR

PF3:31935

### Description

UCS0044Q

The turbine revolution sensor detects input shaft rpm (revolutions per minute). It is located on the input side of the automatic transmission. Monitors revolution of sensor 1 and sensor 2 for non-standard conditions.

### CONSULT-II Reference Value

UCS0044R

Item name	Condition	Display value (rpm)
TURBINE REV	During driving (lock-up ON)	Approximately matches the engine speed.

### On Board Diagnosis Logic

UCS0044S

- This is an OBD-II self-diagnostic item.
- Diagnostic trouble code “P0717 TURBINE REV S/CIRC” with CONSULT-II or 11th judgement flicker without CONSULT-II is detected under the following conditions.
  - When TCM does not receive the proper voltage signal from the sensor.
  - When TCM detects an irregularity only at position of 4th gear for turbine revolution sensor 2.

### Possible Cause

UCS0044T

- Harness or connectors  
(The sensor circuit is open or shorted.)
- Turbine revolution sensor 1, 2

### DTC Confirmation Procedure

UCS0044U

#### CAUTION:

- Always drive vehicle at a safe speed.
- Be careful not to rev engine into the red zone on the tachometer.

#### NOTE:

If “DTC Confirmation Procedure” has been previously performed, always turn ignition switch “OFF” and wait at least 10 seconds before performing the next test.

After the repair, perform the following procedure to confirm the malfunction is eliminated.

#### ④ WITH CONSULT-II

1. Turn ignition switch “ON”. (Do not start engine.)
2. Select “DATA MONITOR” mode for “A/T” with CONSULT-II.
3. Start engine and maintain the following conditions for at least 5 consecutive seconds.

**VHCL SPEED SE: 40 km/h (25 MPH) or more**

**ENGINE SPEED: 1,500 rpm or more**

**ACCELE POS: 0.5/8 or more**

**Selector lever: “D” position**

**Gear position (Turbine revolution sensor 1): 4th or 5th position**

**Gear position (Turbine revolution sensor 2): All position**

**Driving location: Driving the vehicle uphill (increased engine load) will help maintain the driving conditions required for this test.**

4. If DTC is detected, go to [AT-111, "Diagnostic Procedure"](#).

#### ④ WITH GST

Follow the procedure “WITH CONSULT-II”.

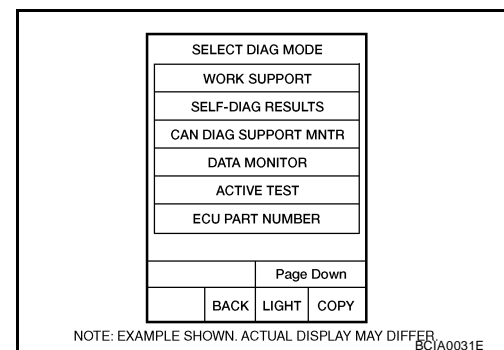

# DTC P0717 TURBINE REVOLUTION SENSOR

UCS0044V

## Diagnostic Procedure

### 1. CHECK INPUT SIGNAL

#### With CONSULT-II

1. Start engine.
2. Select "ECU INPUT SIGNALS" in "DATA MONITOR" mode for "A/T" with CONSULT-II.
3. Vehicle start and read out the value of "TURBINE REV".

#### OK or NG

- OK >> GO TO 4.  
NG >> GO TO 2.

DATA MONITOR	
MONITOR	NO DTC
W/O THL POS	OFF
BRAKE SW	OFF
ENGINE SPEED	0 rpm
TURBINE REV	0 rpm
OUTPUT REV	0 rpm

▽			
RECORD			
MODE	BACK	LIGHT	COPY

PCIA0041E

### 2. CHECK TCM POWER SUPPLY AND GROUND CIRCUIT

Check TCM power supply and ground circuit. Refer to [AT-168, "MAIN POWER SUPPLY AND GROUND CIRCUIT"](#).

#### OK or NG

- OK >> GO TO 3.  
NG >> Repair or replace damaged parts.

### 3. DETECT MALFUNCTIONING ITEM

Check the following.

- The A/T assembly harness connector pin terminals for damage or loose connection with harness connector.

#### OK or NG

- OK >> Replace the control valve with TCM. Refer to [AT-228, "Control Valve With TCM and A/T Fluid Temperature Sensor 2"](#).
- NG >> Repair or replace damaged parts.

### 4. CHECK DTC

Perform "DTC Confirmation Procedure".

- Refer to [AT-110, "DTC Confirmation Procedure"](#).

#### OK or NG

- OK >> **INSPECTION END**  
NG >> GO TO 2.

# DTC P0720 VEHICLE SPEED SENSOR A/T (REVOLUTION SENSOR)

## DTC P0720 VEHICLE SPEED SENSOR A/T (REVOLUTION SENSOR)

PF#:32702

### Description

UCS00437

The revolution sensor detects the revolution of the parking gear and emits a pulse signal. The pulse signal is sent to the TCM which converts it into vehicle speed.

### CONSULT-II Reference Value

UCS00438

Item name	Condition	Display value (km/h)
VHCL/S SE·A/T	During driving	Approximately matches the speedometer reading.

### On Board Diagnosis Logic

UCS00439

- This is an OBD-II self-diagnostic item.
- Diagnostic trouble code "P0720 VEH SPD SEN/CIR AT" with CONSULT-II or 1st judgement flicker without CONSULT-II is detected under the following conditions.
  - When TCM does not receive the proper voltage signal from the sensor.
  - After ignition switch is turned "ON", irregular signal input from vehicle speed sensor MTR before the vehicle starts moving.

### Possible Cause

UCS0043A

- Harness or connectors  
(The sensor circuit is open or shorted.)
- Revolution sensor
- Vehicle speed sensor MTR

### DTC Confirmation Procedure

UCS0043B

#### CAUTION:

- Always drive vehicle at a safe speed.
- Be careful not to rev engine into the red zone on the tachometer.

#### NOTE:

If "DTC Confirmation Procedure" has been previously performed, always turn ignition switch "OFF" and wait at least 10 seconds before performing the next test.

After the repair, perform the following procedure to confirm the malfunction is eliminated.

#### WITH CONSULT-II

1. Turn ignition switch "ON". (Do not start engine.)
2. Select "DATA MONITOR" mode for "A/T" with CONSULT-II.
3. Drive vehicle and check for an increase of "VHCL/S SE·A/T" value in response to "VHCL/S SE·MTR" value.  
If the check result is NG, go to [AT-115, "Diagnostic Procedure"](#) .  
If the check result is OK, go to following step.
4. Select "DATA MONITOR" mode for "ENGINE" with CONSULT-II.
5. Start engine and maintain the following conditions for at least 5 consecutive seconds.  
**VHCL SPEED SE: 30 km/h (19 MPH) or more**  
**THRTL POS SEN: More than 1.0/8**  
**Selector lever: "D" position**  
**Driving location: Driving the vehicle uphill (increased engine load) will help maintain the driving conditions required for this test.**  
If the check result is NG, go to [AT-115, "Diagnostic Procedure"](#) .  
If the check result is OK, go to following step.
6. Maintain the following conditions for at least 5 consecutive seconds.  
**ENGINE SPEED: 3,500 rpm or more**  
**THRTL POS SEN: More than 1.0/8**  
**Selector lever: "D" position**  
**Driving location: Driving the vehicle uphill (increased engine load) will help maintain the driving conditions required for this test.**  
If the check result is NG, go to [AT-115, "Diagnostic Procedure"](#) .

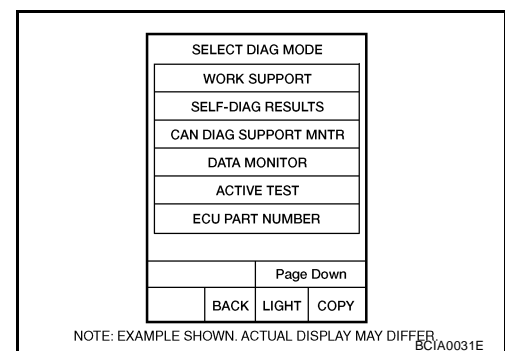



# DTC P0720 VEHICLE SPEED SENSOR A/T (REVOLUTION SENSOR)

---

 **WITH GST**

Follow the procedure "WITH CONSULT-II".

A

B

**AT**

D

E

F

G

H

I

J

K

L

M

# DTC P0720 VEHICLE SPEED SENSOR A/T (REVOLUTION SENSOR)

## Wiring Diagram — AT — VSSA/T

UCS0043C

### AT-VSSA/T-01

: DETECTABLE LINE FOR DTC  
 : NON-DETECTABLE LINE FOR DTC

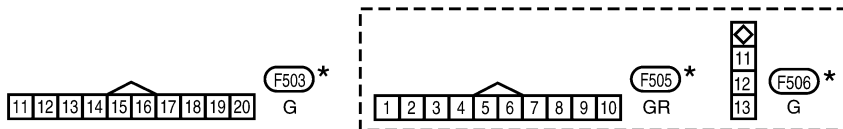
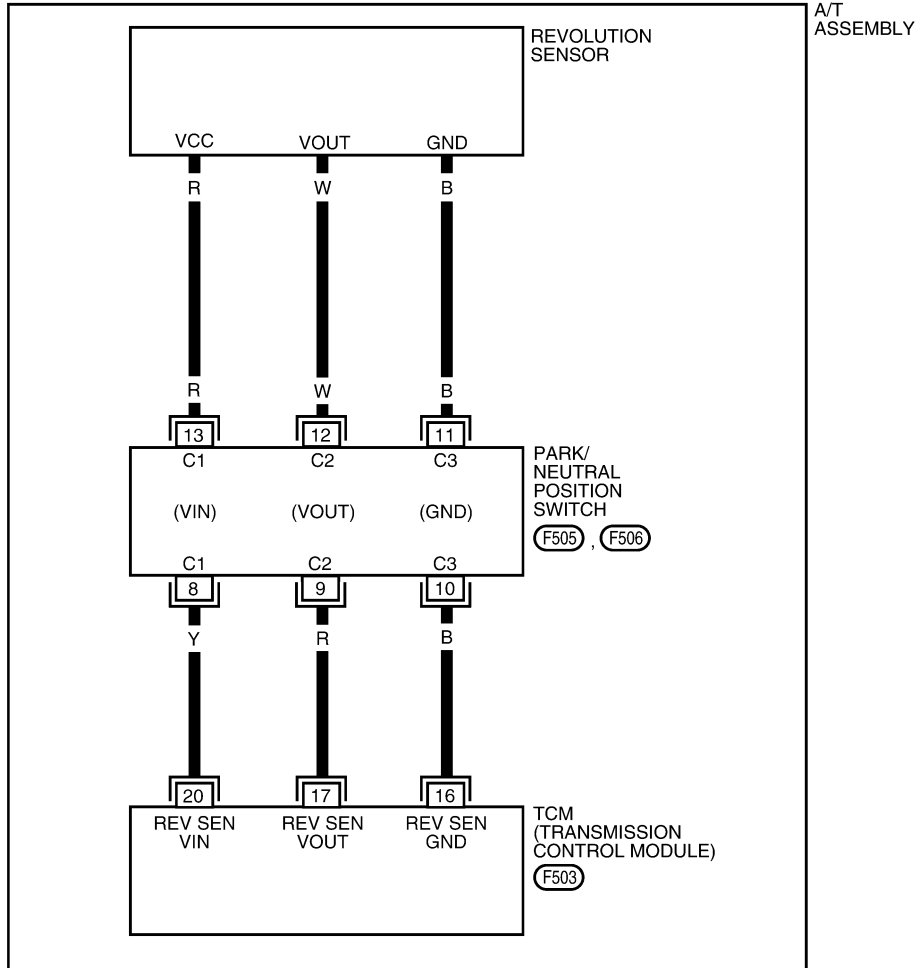

\*: THIS CONNECTOR IS NOT SHOWN IN "HARNESS LAYOUT" OF PG SECTION.

BCWA0403E

# DTC P0720 VEHICLE SPEED SENSOR A/T (REVOLUTION SENSOR)

UCS0043D

## Diagnostic Procedure

### 1. CHECK INPUT SIGNAL

#### With CONSULT-II

- Turn ignition switch ON.
- Select "ECU INPUT SIGNALS" in "DATA MONITOR" mode for "A/T" with CONSULT-II.
- Start the engine.
- Read out the value of "VHCL/S SE-A/T" while driving. Check the value changes according to driving speed.

DATA MONITOR			
MONITOR	NO DTC		
VHCL/S SE-A/T	0km/h		
VHCL/S SE-MTR	0km/h		
ACCELE POSI	0.0/8		
THROTTLE POS	0.0/8		
CLSD THL POS	ON		
W/O THL POS	OFF		
▽			
RECORD			
MODE	BACK	LIGHT	COPY

SCIA2148E

#### OK or NG

- OK >> GO TO 6.  
NG >> GO TO 2.

### 2. CHECK TCM POWER SUPPLY AND GROUND CIRCUIT

Check TCM power supply and ground circuit. Refer to [AT-168, "MAIN POWER SUPPLY AND GROUND CIRCUIT"](#).

#### OK or NG

- OK >> GO TO 3.  
NG >> Repair or replace damaged parts.

### 3. DETECT MALFUNCTIONING ITEM

Check the following.

- The A/T assembly harness connector pin terminals for damage or loose connection with harness connector.

#### OK or NG

- OK >> GO TO 4.  
NG >> Repair or replace damaged parts.

### 4. CHECK SUB-HARNESS

- Remove control valve with TCM. Refer to [AT-228, "Control Valve With TCM and A/T Fluid Temperature Sensor 2"](#).
- Disconnect park/neutral position switch connector and TCM connector.
- Check continuity between park/neutral position switch connector terminals and TCM connector terminals.

Item	Connector	Terminal	Continuity
Park/neutral position switch connector	F505	8	Yes
TCM connector	F503	20	
Park/neutral position switch connector	F505	9	Yes
TCM connector	F503	17	
Park/neutral position switch connector	F505	10	Yes
TCM connector	F503	16	

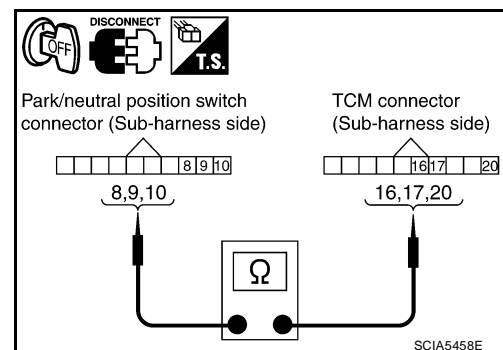

- If OK, check harness for short to ground and short to power.
- Reinstall any part removed.

#### OK or NG

- OK >> GO TO 5.  
NG >> Replace open circuit or short to ground and short to power in harness or connectors.

## DTC P0720 VEHICLE SPEED SENSOR A/T (REVOLUTION SENSOR)

---

### 5. REPLACE THE REVOLUTION SENSOR AND CHECK DTC

---

1. Replace the revolution sensor. Refer to [AT-268, "DISASSEMBLY"](#) .
2. Perform "DTC Confirmation Procedure". Refer to [AT-112, "DTC Confirmation Procedure"](#) .

OK or NG

OK >> **INSPECTION END**

NG >> Replace the control valve with TCM. Refer to [AT-228, "Control Valve With TCM and A/T Fluid Temperature Sensor 2"](#) .

### 6. CHECK DTC

---

Perform "DTC Confirmation Procedure".

- Refer to [AT-112, "DTC Confirmation Procedure"](#) .

OK or NG

OK >> **INSPECTION END**

NG >> GO TO 2.

# DTC P0725 ENGINE SPEED SIGNAL

## DTC P0725 ENGINE SPEED SIGNAL

PF:24825

### Description

UCS0043E

The engine speed signal is sent from the ECM to the TCM.

### CONSULT-II Reference Value

UCS0043F

Item name	Condition	Display value (rpm)
ENGINE SPEED	Engine running	Closely matches the tachometer reading.

### On Board Diagnosis Logic

UCS0043G

- This is not an OBD-II self-diagnostic item.
- Diagnostic trouble code "P0725 ENGINE SPEED SIG" with CONSULT-II or 16th judgement flicker without CONSULT-II is detected when TCM does not receive the ignition signal from ECM during engine cranking or running.

### Possible Cause

UCS0043H

Harness or connectors  
(The ECM to the TCM circuit is open or shorted.)

### DTC Confirmation Procedure

UCS0043I

#### CAUTION:

Always drive vehicle at a safe speed.

#### NOTE:

If "DTC Confirmation Procedure" has been previously performed, always turn ignition switch "OFF" and wait at least 10 seconds before performing the next test.

After the repair, perform the following procedure to confirm the malfunction is eliminated.

#### WITH CONSULT-II

1. Turn ignition switch "ON" and select "DATA MONITOR" mode for "A/T" with CONSULT-II.
2. Start engine and maintain the following conditions for at least 10 consecutive seconds.  
**VHCL SPEED SE: 10 km/h (6 MPH) or more**  
**ACCELE POSI: More than 1/8**  
**Selector lever: "D" position**
3. If DTC is detected, go to [AT-118, "Diagnostic Procedure"](#).

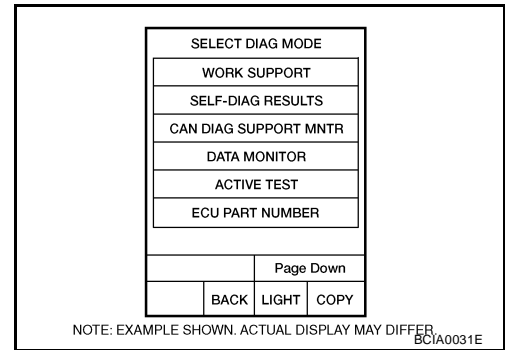

# DTC P0725 ENGINE SPEED SIGNAL

UCS0043J

## Diagnostic Procedure

### 1. CHECK CAN COMMUNICATION LINE

Perform the self-diagnosis. Refer to [AT-89, "SELF-DIAGNOSTIC RESULT MODE"](#) .

Is a malfunction in the CAN communication indicated in the results?

- YES >> Check CAN communication line. Refer to [AT-98, "DTC U1000 CAN COMMUNICATION LINE"](#) .
- NO >> GO TO 2.

### 2. CHECK DTC WITH TCM

#### With CONSULT-II

1. Start engine.
2. Select "ECU INPUT SIGNALS" in "DATA MONITOR" mode for "A/T" with CONSULT-II.
3. While monitoring engine speed, check for engine speed change corresponding to wide-open throttle position signal.

#### OK or NG

- OK >> GO TO 3.
- NG >> Check the ignition signal circuit.
  - Refer to [EC-598, "IGNITION SIGNAL"](#) (QR) or [EC-1270, "IGNITION SIGNAL"](#) (VQ).

DATA MONITOR			
MONITOR	NO DTC		
W/O THL POS	OFF		
BRAKE SW	OFF		
ENGINE SPEED	0 rpm		
TURBINE REV	0 rpm		
OUTPUT REV	0 rpm		
▽			
RECORD			
MODE	BACK	LIGHT	COPY

PCIA0041E

### 3. CHECK DTC

Perform "DTC Confirmation Procedure".

- Refer to [AT-117, "DTC Confirmation Procedure"](#) .

#### OK or NG

- OK >> **INSPECTION END**
- NG >> GO TO 4.

### 4. CHECK TCM POWER SUPPLY AND GROUND CIRCUIT

Check TCM power supply and ground circuit. Refer to [AT-168, "MAIN POWER SUPPLY AND GROUND CIRCUIT"](#) .

#### OK or NG

- OK >> GO TO 5.
- NG >> Repair or replace damaged parts.

### 5. DETECT MALFUNCTIONING ITEM

Check the following.

- The A/T assembly harness connector pin terminals for damage or loose connection with harness connector.

#### OK or NG

- OK >> Replace the control valve with TCM. Refer to [AT-228, "Control Valve With TCM and A/T Fluid Temperature Sensor 2"](#) .
- NG >> Repair or replace damaged parts.

# DTC P0740 TORQUE CONVERTER CLUTCH SOLENOID VALVE

## DTC P0740 TORQUE CONVERTER CLUTCH SOLENOID VALVE

PFP:31940

### Description

UCS0043K

- The torque converter clutch solenoid valve is activated, with the gear in D4 , D5 by the TCM in response to signals sent from the vehicle speed sensor and accelerator pedal position sensor (throttle position sensor). Torque converter clutch piston operation will then be controlled.
- Lock-up operation, however, is prohibited when A/T fluid temperature is too low.
- When the accelerator pedal is depressed (less than 1/8) in lock-up condition, the engine speed should not change abruptly. If there is a big jump in engine speed, there is no lock-up.

### CONSULT-II Reference Value

UCS0043L

Item name	Condition	Display value (Approx.)
TCC SOLENOID	When performing slip lock-up	0.2 - 0.4 A
	When performing lock-up	0.4 - 0.6 A

### On Board Diagnosis Logic

UCS0043M

- This is an OBD-II self-diagnostic item.
- Diagnostic trouble code “P0740 TCC SOLENOID/CIRC” with CONSULT-II or 3rd judgement flicker without CONSULT-II is detected under the following conditions.
  - When TCM detects an improper voltage drop when it tries to operate the solenoid valve.
  - When TCM detects as irregular by comparing target value with monitor value.

### Possible Cause

UCS0043N

- Torque converter clutch solenoid valve
- Harness or connectors  
(The solenoid circuit is open or shorted.)

### DTC Confirmation Procedure

UCS0043O

#### CAUTION:

Always drive vehicle at a safe speed.

#### NOTE:

If “DTC Confirmation Procedure” has been previously performed, always turn ignition switch “OFF” and wait at least 10 seconds before performing the next test.

After the repair, perform the following procedure to confirm the malfunction is eliminated.

#### WITH CONSULT-II

1. Turn ignition switch “ON”. (Do not start engine.)
2. Select “DATA MONITOR” mode for “ENGINE” with CONSULT-II.
3. Start engine and maintain the following conditions for at least 5 consecutive seconds.

**VHCL SPEED SE: 80 km/h (50 MPH) or more**

**ACCELE POS: 0.5/8 - 1.0/8**

**SELECTOR LEVER: “D” position**

**Driving location: Driving the vehicle uphill (increased engine load) will help maintain the driving conditions required for this test.**

4. If DTC is detected go to [AT-120, "Diagnostic Procedure"](#).

#### WITH GST

Follow the procedure “WITH CONSULT-II”.

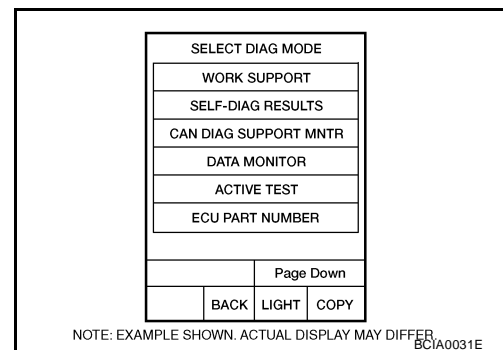

# DTC P0740 TORQUE CONVERTER CLUTCH SOLENOID VALVE

UCS0043P

## Diagnostic Procedure

### 1. CHECK INPUT SIGNAL

#### With CONSULT-II

1. Turn ignition switch ON.
2. Select "MAIN SIGNALS" in "DATA MONITOR" mode for "A/T" with CONSULT-II.
3. Start engine.
4. Read out the value of "TCC SOLENOID" while driving.

#### OK or NG

- OK >> GO TO 4.  
NG >> GO TO 2.

DATA MONITOR			
MONITOR		NO DTC	
TCC SOLENOID	XXXX		
LINE PRES SOL	XXXX		
I/C SOLENOID	XXXX		
FR/B SOLENOID	XXXX		
D/C SOLENOID	XXXX		
HLR/C SOL	XXXX		
			▽
			RECORD
MODE	BACK	LIGHT	COPY

SCIA4793E

### 2. CHECK TCM POWER SUPPLY AND GROUND CIRCUIT

Check TCM power supply and ground circuit. Refer to [AT-168, "MAIN POWER SUPPLY AND GROUND CIRCUIT"](#).

#### OK or NG

- OK >> GO TO 3.  
NG >> Repair or replace damaged parts.

### 3. DETECT MALFUNCTIONING ITEM

Check the following.

- The A/T assembly harness connector pin terminals for damage or loose connection with harness connector.

#### OK or NG

- OK >> Replace the control valve with TCM. Refer to [AT-228, "Control Valve With TCM and A/T Fluid Temperature Sensor 2"](#).  
NG >> Repair or replace damaged parts.

### 4. CHECK DTC

Perform "DTC Confirmation Procedure".

- Refer to [AT-119, "DTC Confirmation Procedure"](#).

#### OK or NG

- OK >> **INSPECTION END**  
NG >> GO TO 2.



# DTC P0744 A/T TCC S/V FUNCTION (LOCK-UP)

## DTC P0744 A/T TCC S/V FUNCTION (LOCK-UP)

PF:31940

### Description

UCS0043Q

This malfunction is detected when the A/T does not shift into 5th gear position or the torque converter clutch does not lock-up as instructed by the TCM. This is not only caused by electrical malfunction (circuits open or shorted) but also by mechanical malfunction such as control valve sticking, improper solenoid valve operation, etc.

### CONSULT-II Reference Value

UCS0043R

Item name	Condition	Display value (Approx.)
TCC SOLENOID	When performing slip lock-up	0.2 - 0.4 A
	When performing lock-up	0.4 - 0.6 A

### On Board Diagnosis Logic

UCS0043S

- This is an OBD-II self-diagnostic item.
- Diagnostic trouble code “P0744 A/T TCC S/V FNCTN” with CONSULT-II is detected under the following conditions.
  - When A/T cannot perform lock-up even if electrical circuit is good.
  - When TCM detects as irregular by comparing difference value with slip rotation.

### Possible Cause

UCS0043T

- Harness or connectors  
(The solenoid circuit is open or shorted.)
- Torque converter clutch solenoid valve
- Hydraulic control circuit

### DTC Confirmation Procedure

UCS0043U

#### CAUTION:

Always drive vehicle at a safe speed.

#### NOTE:

If “DTC Confirmation Procedure” has been previously performed, always turn ignition switch “OFF” and wait at least 10 seconds before performing the next test.

After the repair, perform the following procedure to confirm the malfunction is eliminated.

#### WITH CONSULT-II

1. Start engine and Select “TCC SOL FNCTN CHECK” of “DTC WORK SUPPORT” mode for “A/T” with CONSULT-II and touch “START”.
2. Accelerate vehicle to more than 80 km/h (50 MPH) and maintain the following condition continuously until “TESTING” has turned to “COMPLETE”. (It will take approximately 30 seconds after “TESTING” shows.)

**ACCELE POSI: More than 1.0/8 (at all times during step 4)**

**TCC SOLENOID: 0.4 - 0.6 A**

**Selector lever: “D” position**

**[Reference speed: Constant speed of more than 80 km/h (50 MPH)]**

- Make sure “GEAR” shows “5”.
  - For shift schedule, refer to [AT-62, "Vehicle Speed at Which Lock-up Occurs/Releases"](#) .
  - If “TESTING” does not appear on CONSULT-II for a long time, select “SELF-DIAG RESULTS”. In case a 1st trip DTC other than P0744 is shown, refer to applicable “TROUBLE DIAGNOSIS FOR DTC”.
3. Make sure that “OK” is displayed. (If “NG” is displayed, refer to “DIAGNOSTIC PROCEDURE”.)  
Refer to [AT-122, "Diagnostic Procedure"](#) .  
Refer to shift schedule [AT-62, "Vehicle Speed at Which Lock-up Occurs/Releases"](#) .

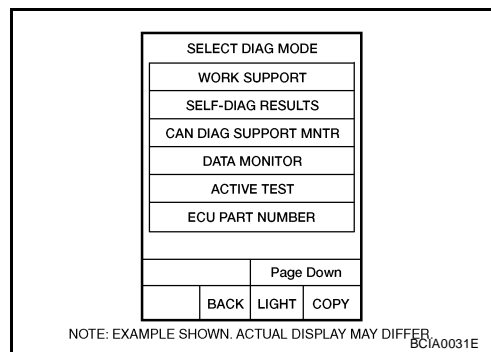

# DTC P0744 A/T TCC S/V FUNCTION (LOCK-UP)

## WITH GST

Follow the procedure "WITH CONSULT-II".

### Diagnostic Procedure

UCS0043V

#### 1. CHECK INPUT SIGNAL

##### With CONSULT-II

1. Turn ignition switch ON.
2. Select "MAIN SIGNALS" in "DATA MONITOR" mode for "A/T" with CONSULT-II.
3. Start the engine.
4. Read out the value of "TCC SOLENOID" while driving.

##### OK or NG

- OK >> GO TO 4.  
NG >> GO TO 2.

DATA MONITOR	
MONITOR	NO DTC
TCC SOLENOID	XXXX
LINE PRES SOL	XXXX
I/C SOLENOID	XXXX
FR/B SOLENOID	XXXX
D/C SOLENOID	XXXX
HLR/C SOL	XXXX
	▽
	RECORD
MODE	BACK
LIGHT	COPY

SCIA4793E

#### 2. CHECK TCM POWER SUPPLY AND GROUND CIRCUIT

Check TCM power supply and ground circuit. Refer to [AT-168, "MAIN POWER SUPPLY AND GROUND CIRCUIT"](#).

##### OK or NG

- OK >> GO TO 3.  
NG >> Repair or replace damaged parts.

#### 3. DETECT MALFUNCTIONING ITEM

Check the following.

- The A/T assembly harness connector pin terminals for damage or loose connection with harness connector.

##### OK or NG

- OK >> Replace the control valve with TCM. Refer to [AT-228, "Control Valve With TCM and A/T Fluid Temperature Sensor 2"](#).
- NG >> Repair or replace damaged parts.

#### 4. CHECK DTC

Perform "DTC Confirmation Procedure".

- Refer to [AT-121, "DTC Confirmation Procedure"](#).

##### OK or NG

- OK >> **INSPECTION END**  
NG >> GO TO 2.

# DTC P0745 LINE PRESSURE SOLENOID VALVE

## DTC P0745 LINE PRESSURE SOLENOID VALVE

PF3:31940

### Description

UCS0043W

The line pressure solenoid valve regulates the oil pump discharge pressure to suit the driving condition in response to a signal sent from the TCM.

### CONSULT-II Reference Value

UCS0043X

Item name	Condition	Display value (Approx.)
LINE PRES SOL	During driving	0.2 - 0.6 A

### On Board Diagnosis Logic

UCS0043Y

- This is an OBD-II self-diagnostic item.
- Diagnostic trouble code "P0745 L/PRESS SOL/CIRC" with CONSULT-II or 4th judgement flicker without CONSULT-II is detected under the following conditions.
  - When TCM detects an improper voltage drop when it tries to operate the solenoid valve.
  - When TCM detects as irregular by comparing target value with monitor value.

### Possible Cause

UCS0043Z

- Harness or connectors  
(The solenoid circuit is open or shorted.)
- Line pressure solenoid valve

### DTC Confirmation Procedure

UCS00440

#### NOTE:

If "DTC Confirmation Procedure" has been previously performed, always turn ignition switch "OFF" and wait at least 10 seconds before performing the next test.

After the repair, perform the following procedure to confirm the malfunction is eliminated.

#### WITH CONSULT-II

1. Turn ignition switch "ON" and select "DATA MONITOR" mode for "ENGINE" with CONSULT-II.
2. Engine start and wait at least 5 second.
3. If DTC is detected, go to [AT-124, "Diagnostic Procedure"](#).

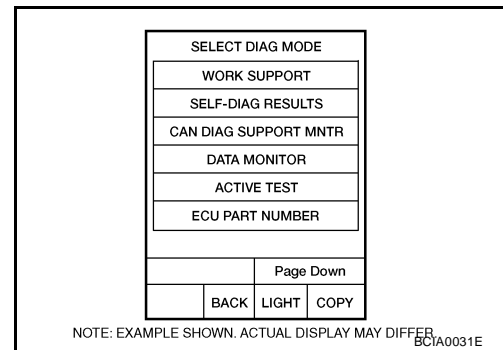

#### WITH GST

Follow the procedure "WITH CONSULT-II".

# DTC P0745 LINE PRESSURE SOLENOID VALVE

UCS00441

## Diagnostic Procedure

### 1. CHECK INPUT SIGNAL

#### With CONSULT-II

1. Turn ignition switch ON.
2. Select "MAIN SIGNALS" in "DATA MONITOR" mode for "A/T" with CONSULT-II.
3. Start the engine.
4. Read out the value of "LINE PRES SOL" while driving.

#### OK or NG

- OK >> GO TO 4.  
NG >> GO TO 2.

DATA MONITOR			
MONITOR		NO DTC	
TCC SOLENOID		XXXX	
LINE PRES SOL		XXXX	
I/C SOLENOID		XXXX	
FR/B SOLENOID		XXXX	
D/C SOLENOID		XXXX	
HLR/C SOL		XXXX	
		▽	
		RECORD	
MODE	BACK	LIGHT	COPY

SCIA4793E

### 2. CHECK TCM POWER SUPPLY AND GROUND CIRCUIT

Check TCM power supply and ground circuit. Refer to [AT-168, "MAIN POWER SUPPLY AND GROUND CIRCUIT"](#).

#### OK or NG

- OK >> GO TO 3.  
NG >> Repair or replace damaged parts.

### 3. DETECT MALFUNCTIONING ITEM

Check the following.

- The A/T assembly harness connector pin terminals for damage or loose connection with harness connector.

#### OK or NG

- OK >> Replace the control valve with TCM. Refer to [AT-228, "Control Valve With TCM and A/T Fluid Temperature Sensor 2"](#).  
NG >> Repair or replace damaged parts.

### 4. CHECK DTC

Perform "DTC Confirmation Procedure".

- Refer to [AT-123, "DTC Confirmation Procedure"](#).

#### OK or NG

- OK >> **INSPECTION END**  
NG >> GO TO 2.

# DTC P1705 THROTTLE POSITION SENSOR

## DTC P1705 THROTTLE POSITION SENSOR

PFP:22620

### Description

UCS0044C

Electric throttle control actuator consists of throttle control motor, accelerator pedal position sensor, throttle position sensor, etc. The actuator sends a signal to the ECM, and ECM sends signals to TCM with CAN communication.

### CONSULT-II Reference Value

UCS0044D

Item name	Condition	Display value (Approx.)
ACCELE POSI	Released accelerator pedal.	0.0/8
	Fully depressed accelerator pedal.	8/8

### On Board Diagnosis Logic

UCS0044E

- This is not an OBD-II self-diagnostic item.
- Diagnostic trouble code "P1705 TP SEN/CIRC A/T" with CONSULT-II or 15th judgement flicker without CONSULT-II is detected when TCM does not receive the proper accelerator pedal position signals (input by CAN communication) from ECM.

### Possible Cause

UCS0044F

Harness or connectors  
(The sensor circuit is open or shorted.)

### DTC Confirmation Procedure

UCS0044G

#### NOTE:

If "DTC Confirmation Procedure" has been previously performed, always turn ignition switch "OFF" and wait at least 10 seconds before performing the next test.

After the repair, perform the following procedure to confirm the malfunction is eliminated.

#### WITH CONSULT-II

1. Turn ignition switch "ON". (Do not start engine.)
2. Select "DATA MONITOR" mode for "A/T" with CONSULT-II.
3. Start engine and let it idle for 1 second.
4. If DTC is detected, go to [AT-126. "Diagnostic Procedure"](#).

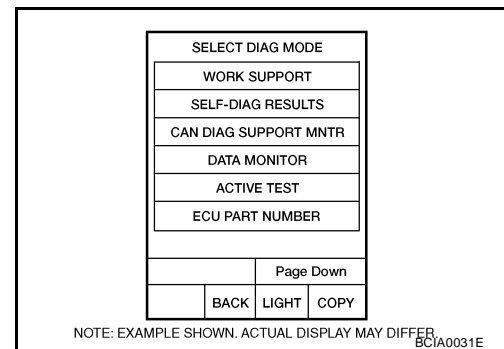

# DTC P1705 THROTTLE POSITION SENSOR

UCS0044H

## Diagnostic Procedure

### 1. CHECK CAN COMMUNICATION LINE

Perform the self-diagnosis. Refer to [AT-89, "SELF-DIAGNOSTIC RESULT MODE"](#) .

Is a malfunction in the CAN communication indicated in the results?

- YES >> Check CAN communication line. Refer to [AT-98, "DTC U1000 CAN COMMUNICATION LINE"](#) .
- NO >> GO TO 2.

### 2. CHECK DTC WITH TCM

#### With CONSULT-II

1. Turn ignition switch ON. (Do not start engine.)
2. Select "ECU INPUT SIGNALS" in "DATA MONITOR" mode for "A/T" with CONSULT-II.
3. Depress accelerator pedal and read out the value of "ACCELE POSI".
4. Select "SELF-DIAG RESULTS" mode for "A/T" with CONSULT-II. Refer to [AT-89, "SELF-DIAGNOSTIC RESULT MODE"](#) .

OK or NG

- OK >> GO TO 4.
- NG >> GO TO 3.

DATA MONITOR	
MONITOR	NO DTC
ACCELE POSI	0.0/8
THROTTLE POSI	0.0/8
CLSD THL POS	ON
W/O THL POS	OFF
BRAKE SW	OFF

		▼	
		RECORD	
MODE	BACK	LIGHT	COPY

PCIA0070E

### 3. CHECK DTC WITH ECM

#### With CONSULT-II

1. Turn ignition switch ON. (Do not start engine.)
2. Select "SELF-DIAG RESULTS" mode for "ENGINE" with CONSULT-II. Refer to [EC-118, "CONSULT-II Function \(ENGINE\)"](#) (QR) or [EC-725, "CONSULT-II Function \(ENGINE\)"](#) (VQ).

OK or NG

- OK >> GO TO 4.
- NG >> Check the DTC detected item. Refer to [EC-118, "CONSULT-II Function \(ENGINE\)"](#) (QR) or [EC-725, "CONSULT-II Function \(ENGINE\)"](#) (VQ).
  - If CAN communication line is detected, go to [AT-98, "DTC U1000 CAN COMMUNICATION LINE"](#) .

SELECT DIAG MODE			
WORK SUPPORT			
SELF-DIAG RESULTS			
CAN DIAG SUPPORT MNTR			
DATA MONITOR			
ACTIVE TEST			
ECU PART NUMBER			
		Page Down	
	BACK	LIGHT	COPY

NOTE: EXAMPLE SHOWN. ACTUAL DISPLAY MAY DIFFER.  
BCIA0031E

### 4. CHECK DTC

Perform "DTC Confirmation Procedure".

- Refer to [AT-125, "DTC Confirmation Procedure"](#) .

OK or NG

- OK >> **INSPECTION END**
- NG >> GO TO 5.

### 5. CHECK TCM POWER SUPPLY AND GROUND CIRCUIT

Check TCM power supply and ground circuit. Refer to [AT-168, "MAIN POWER SUPPLY AND GROUND CIRCUIT"](#) .

OK or NG

- OK >> GO TO 6.
- NG >> Repair or replace damaged parts.

# DTC P1705 THROTTLE POSITION SENSOR

---

## 6. DETECT MALFUNCTIONING ITEM

---

Check the following.

- The A/T assembly harness connector pin terminals for damage or loose connection with harness connector.

OK or NG

OK >> Replace the control valve with TCM. Refer to [AT-228, "Control Valve With TCM and A/T Fluid Temperature Sensor 2"](#).

NG >> Repair or replace damaged parts.

A

B

AT

D

E

F

G

H

I

J

K

L

M

# DTC P1710 A/T FLUID TEMPERATURE SENSOR CIRCUIT

## DTC P1710 A/T FLUID TEMPERATURE SENSOR CIRCUIT

PF3:31940

### Description

UCS0044I

The A/T fluid temperature sensor detects the A/T fluid temperature and sends a signal to the TCM.

### CONSULT-II Reference Value

UCS0044J

Item name	Condition °C (°F)	Display value (Approx.)
ATF TEMP SE 1	0 (32) - 20 (68) - 80 (176)	3.3 - 2.7 - 0.9 V
ATF TEMP SE 2		3.3 - 2.5 - 0.7 V

### On Board Diagnosis Logic

UCS0044K

- This is an OBD-II self-diagnostic item.
- Diagnostic trouble code "P1710 (A/T), P0710 (ENGINE) ATF TEMP SEN/CIRC" with CONSULT-II or 10th judgement flicker without CONSULT-II is detected when TCM receives an excessively low or high voltage from the sensor.

### Possible Cause

UCS0044L

- Harness or connectors  
(The sensor circuit is open or shorted.)
- A/T fluid temperature sensors 1, 2

### DTC Confirmation Procedure

UCS0044M

#### CAUTION:

Always drive vehicle at a safe speed.

#### NOTE:

If "DTC Confirmation Procedure" has been previously performed, always turn ignition switch "OFF" and wait at least 10 seconds before performing the next test.

After the repair, perform the following procedure to confirm the malfunction is eliminated.

#### ④ WITH CONSULT-II

1. Turn ignition switch "ON". (Do not start engine.)
2. Select "DATA MONITOR" mode for "ENGINE" with CONSULT-II.
3. Start engine and maintain the following conditions for at least 10 minutes (Total). (It is not necessary to maintain continuously.)  
**VHCL SPEED SE: 10 km/h (6 MPH) or more**  
**THRTL POS SEN: More than 1.0/8**  
**Selector lever: "D" position**
4. If DTC is detected, go to [AT-130, "Diagnostic Procedure"](#).

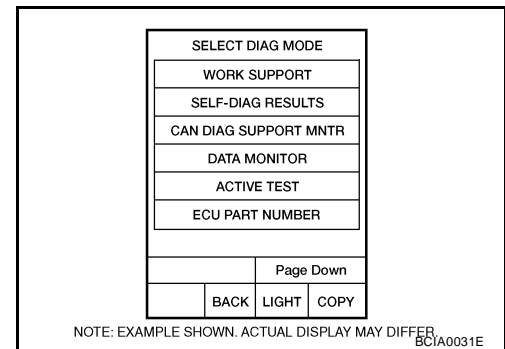

#### ④ WITH GST

Follow the procedure "WITH CONSULT-II".



# DTC P1710 A/T FLUID TEMPERATURE SENSOR CIRCUIT

## Wiring Diagram — AT — FTS

UCS0044N

### AT-FTS-01

: DETECTABLE LINE FOR DTC  
 : NON-DETECTABLE LINE FOR DTC

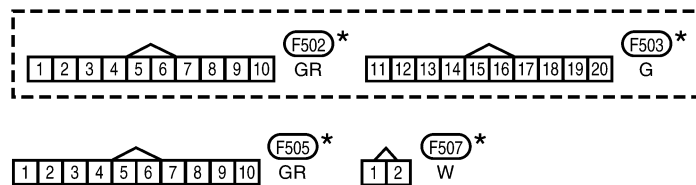
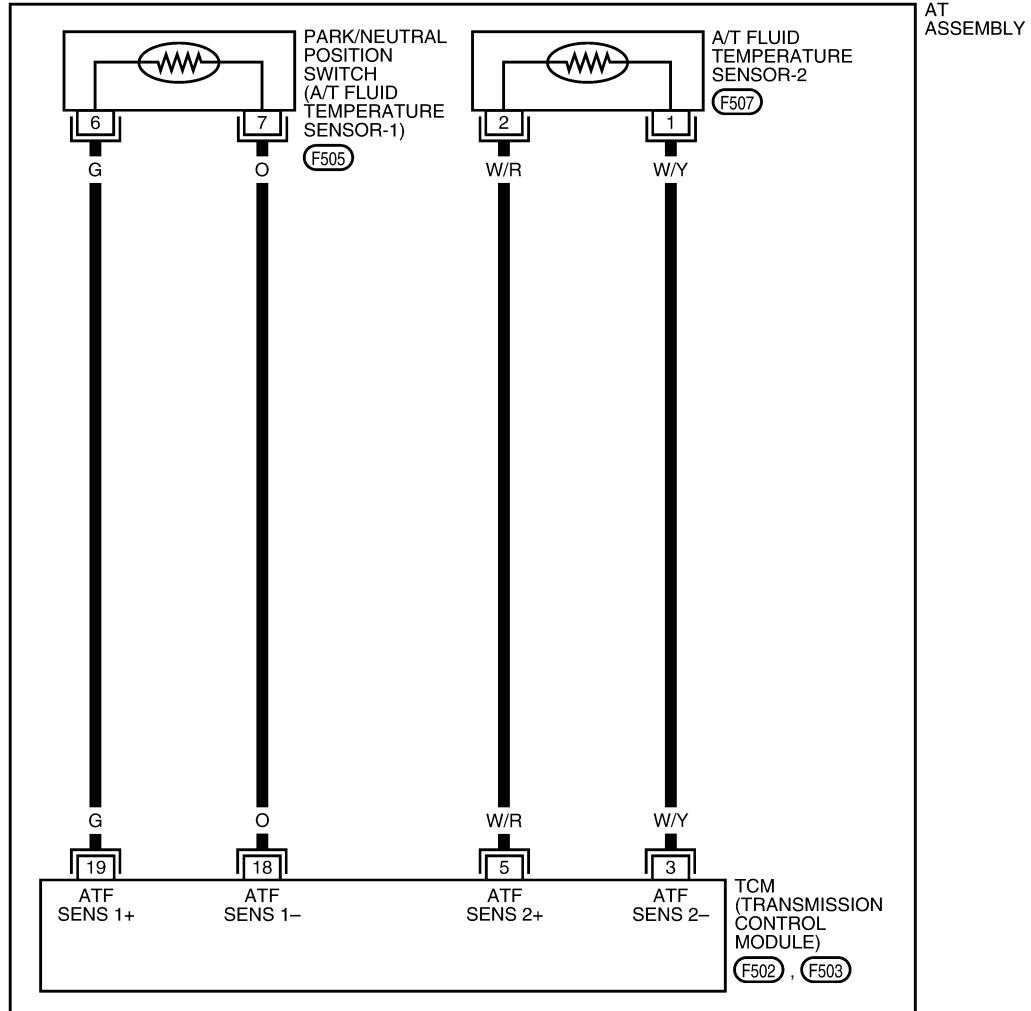

\*: THIS CONNECTOR IS NOT SHOWN IN "HARNESS LAYOUT" OF PG SECTION.

BCWA0323E

# DTC P1710 A/T FLUID TEMPERATURE SENSOR CIRCUIT

UCS00440

## Diagnostic Procedure

### 1. CHECK A/T FLUID TEMPERATURE SENSOR 1 SIGNAL

#### With CONSULT-II

1. Start engine.
2. Select "ECU INPUT SIGNALS" in "DATA MONITOR" mode for "A/T" with CONSULT-II.
3. Read out the value of "ATF TEMP SE 1".

#### OK or NG

- OK >> GO TO 2.  
NG >> GO TO 3.

DATA MONITOR	
MONITOR	NO. DTC
OUTPUT REV	0 rpm
ATF TEMP SE 1	1.84 v
ATF TEMP SE 2	1.72 v
BATTERY BOLT	11.5 v
ATF PRES SW 1	OFF

Δ	▽
RECORD	
MODE	BACK
LIGHT	COPY

PCIA0039E

### 2. CHECK A/T FLUID TEMPERATURE SENSOR 2 SIGNAL

#### With CONSULT-II

1. Start engine.
2. Select "ECU INPUT SIGNALS" in "DATA MONITOR" mode for "A/T" with CONSULT-II.
3. Read out the value of "ATF TEMP SE 2".

#### OK or NG

- OK >> GO TO 8.  
NG >> GO TO 5.

DATA MONITOR	
MONITOR	NO. DTC
OUTPUT REV	0 rpm
ATF TEMP SE 1	1.84 v
ATF TEMP SE 2	1.72 v
BATTERY BOLT	11.5 v
ATF PRES SW 1	OFF

Δ	▽
RECORD	
MODE	BACK
LIGHT	COPY

PCIA0039E

### 3. CHECK A/T FLUID TEMPERATURE SENSOR 1

Check A/T fluid temperature sensor 1. Refer to [AT-132, "A/T FLUID TEMPERATURE SENSOR 1"](#).

#### OK or NG

- OK >> GO TO 4.  
NG >> Replace the control valve with TCM. Refer to [AT-228, "Control Valve With TCM and A/T Fluid Temperature Sensor 2"](#).

### 4. CHECK SUB-HARNESS

1. Disconnect park/neutral position switch connector and TCM connector.
2. Check continuity between park/neutral position switch connector terminals and TCM connector terminals.

Item	Connector	Terminal	Continuity
Park/neutral position switch connector	F505	6	Yes
TCM connector	F503	19	
Park/neutral position switch connector	F505	7	Yes
TCM connector	F503	18	

3. If OK, check harness for short to ground and short to power.

#### OK or NG

- OK >> GO TO 7.  
NG >> Replace open circuit or short to ground and short to power in harness or connectors.

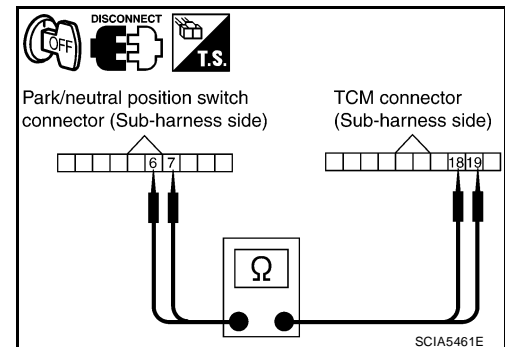

# DTC P1710 A/T FLUID TEMPERATURE SENSOR CIRCUIT

## 5. CHECK A/T FLUID TEMPERATURE SENSOR 2

Check A/T fluid temperature sensor 2. Refer to [AT-132, "A/T FLUID TEMPERATURE SENSOR 2"](#) .

OK or NG

OK >> GO TO 6.

NG >> Replace the A/T fluid temperature sensor 2. Refer to [AT-235, "A/T FLUID TEMPERATURE SENSOR 2 REMOVAL AND INSTALLATION"](#) .

## 6. CHECK TERMINAL CORD ASSEMBLY

1. Disconnect A/T fluid temperature sensor 2 connector and TCM connector.
2. Check continuity between A/T fluid temperature sensor 2 connector terminals and TCM connector terminals.

Item	Connector	Terminal	Continuity
A/T fluid temperature sensor 2 connector	F507	1	Yes
TCM connector	F502	3	
A/T fluid temperature sensor 2 connector	F507	2	Yes
TCM connector	F502	5	

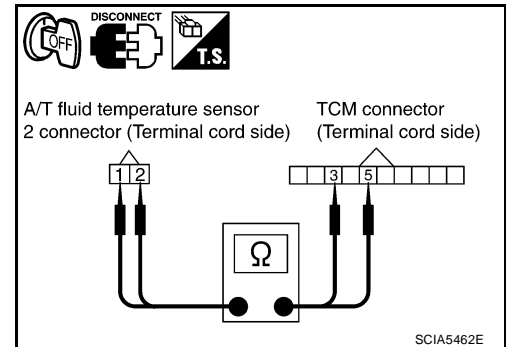

3. If OK, check harness for short to ground and short to power.

OK or NG

OK >> GO TO 7.

NG >> Replace open circuit or short to ground and short to power in harness or connectors.

## 7. CHECK TCM POWER SUPPLY AND GROUND CIRCUIT

1. Check TCM power supply and ground circuit. Refer to [AT-168, "MAIN POWER SUPPLY AND GROUND CIRCUIT"](#) .
2. Reinstall any part removed.

OK or NG

OK >> Replace the control valve with TCM. Refer to [AT-228, "Control Valve With TCM and A/T Fluid Temperature Sensor 2"](#) .

NG >> Repair or replace damaged parts.

## 8. CHECK DTC

Perform "DTC Confirmation Procedure".

- Refer to [AT-128, "DTC Confirmation Procedure"](#) .

OK or NG

OK >> **INSPECTION END**

NG >> GO TO 1.

# DTC P1710 A/T FLUID TEMPERATURE SENSOR CIRCUIT

UCS0044P

## Component Inspection

### A/T FLUID TEMPERATURE SENSOR 1

1. Remove control valve with TCM. Refer to [AT-228, "Control Valve With TCM and A/T Fluid Temperature Sensor 2"](#).
2. Check resistance between terminals.

Name	Terminal	Temperature °C (°F)	Resistance (Approx.)
A/T fluid temperature sensor 1	6 - 7	0 (32)	15 kΩ
		20 (68)	6.5 kΩ
		80 (176)	0.9 kΩ

3. If NG, replace the control valve with TCM. Refer to [AT-228, "Control Valve With TCM and A/T Fluid Temperature Sensor 2"](#).

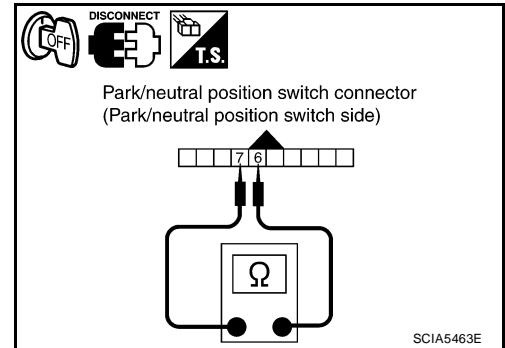

### A/T FLUID TEMPERATURE SENSOR 2

1. Remove A/T fluid temperature sensor 2. Refer to [AT-235, "A/T FLUID TEMPERATURE SENSOR 2 REMOVAL AND INSTALLATION"](#).
2. Check resistance between terminals.

Name	Terminal	Temperature °C (°F)	Resistance (Approx.)
A/T fluid temperature sensor 2	1 - 2	0 (32)	10 kΩ
		20 (68)	4 kΩ
		80 (176)	0.5 kΩ

3. If NG, replace the A/T fluid temperature sensor 2. Refer to [AT-235, "A/T FLUID TEMPERATURE SENSOR 2 REMOVAL AND INSTALLATION"](#).

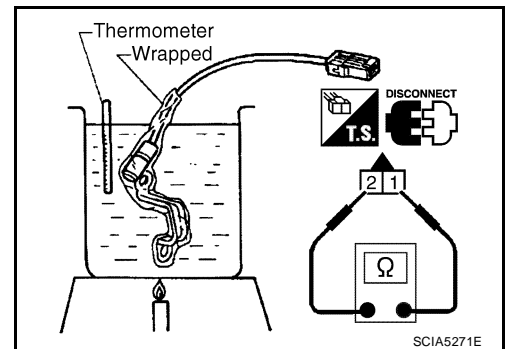

# DTC P1721 VEHICLE SPEED SENSOR MTR

## DTC P1721 VEHICLE SPEED SENSOR MTR

PDF:24814

### Description

UCS0044W

The vehicle speed sensor-MTR signal is transmitted from combination meter to TCM by CAN communication line. The signal functions as an auxiliary device to the revolution sensor when it is malfunctioning. The TCM will then use the vehicle speed sensor-MTR signal.

### CONSULT-II Reference Value

UCS0044X

Item name	Condition	Display value (km/h)
VHCL/S SE-MTR	During driving	Approximately matches the speedometer reading.

### On Board Diagnosis Logic

UCS0044Y

- This is not an OBD-II self-diagnostic item.
- Diagnostic trouble code "P1721 VEH SPD SE-MTR" with CONSULT-II is detected when TCM does not receive the proper vehicle speed sensor MTR signal (input by CAN communication) from combination meter.

### Possible Cause

UCS0044Z

Harness or connectors  
(The sensor circuit is open or shorted.)

### DTC Confirmation Procedure

UCS00450

#### CAUTION:

Always drive vehicle at a safe speed.

#### NOTE:

If "DTC Confirmation Procedure" has been previously performed, always turn ignition switch "OFF" and wait at least 10 seconds before performing the next test.

After the repair, perform the following procedure to confirm the malfunction is eliminated.

#### WITH CONSULT-II

1. Turn ignition switch "ON". (Do not start engine.)
2. Select "DATA MONITOR" mode for "A/T" with CONSULT-II.
3. Start engine and maintain the following conditions for at least 5 consecutive seconds.  
**ACCELE POS: 1/8 or less**  
**VHCL SPEED SE: 30 km/h (17 MPH) or more**
4. If DTC is detected, go to [AT-134, "Diagnostic Procedure"](#).

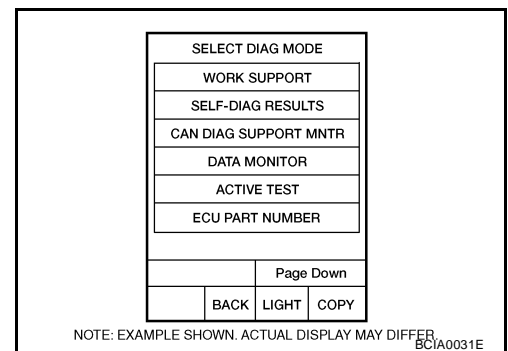

# DTC P1721 VEHICLE SPEED SENSOR MTR

UCS00451

## Diagnostic Procedure

### 1. CHECK CAN COMMUNICATION LINE

Perform the self-diagnosis. Refer to [AT-89, "SELF-DIAGNOSTIC RESULT MODE"](#) .

Is malfunction in the CAN communication indicated in the result?

- YES >> Check CAN communication line. Refer to [AT-98, "DTC U1000 CAN COMMUNICATION LINE"](#) .  
NO >> GO TO 2.

### 2. CHECK INPUT SIGNAL

#### With CONSULT-II

1. Start engine.
2. Select "ECU INPUT SIGNALS" in "DATA MONITOR" mode for "A/T" with CONSULT-II.
3. Drive vehicle and read out the value of "VHCL/S SE·MTR".

OK or NG

- OK >> GO TO 4.  
NG >> GO TO 3.

DATA MONITOR	
MONITOR	NO DTC
VHCL/S SE-A/T	0km/h
VHCL/S SE-MTR	0km/h
ACCELE POSI	0.0/8
THROTTLE POS	0.0/8
CLSD THL POS	ON
W/O THL POS	OFF
	▽
	RECORD
MODE	BACK
LIGHT	COPY

SCIA2148E

### 3. CHECK COMBINATION METERS

Check combination meters. Refer to [DI-18, "How to Proceed With Trouble Diagnosis"](#) .

OK or NG

- OK >> GO TO 4.  
NG >> Repair or replace damaged parts.

### 4. CHECK DTC

Perform "DTC Confirmation Procedure".

- Refer to [AT-133, "DTC Confirmation Procedure"](#) .

OK or NG

- OK >> **INSPECTION END**  
NG >> GO TO 5.

### 5. CHECK TCM POWER SUPPLY AND GROUND CIRCUIT

Check TCM power supply and ground circuit. Refer to [AT-168, "MAIN POWER SUPPLY AND GROUND CIRCUIT"](#) .

OK or NG

- OK >> GO TO 6.  
NG >> Repair or replace damaged parts.

### 6. DETECT MALFUNCTIONING ITEM

Check the following.

- The A/T assembly harness connector pin terminals for damage or loose connection with harness connector.

OK or NG

- OK >> Replace the control valve with TCM. Refer to [AT-228, "Control Valve With TCM and A/T Fluid Temperature Sensor 2"](#) .  
NG >> Repair or replace damaged parts.

# DTC P1730 A/T INTERLOCK

## DTC P1730 A/T INTERLOCK

PF0:0000

### Description

UCS00452

- Fail-safe function to detect interlock conditions.

### On Board Diagnosis Logic

UCS00453

- This is an OBD-II self-diagnostic item.
- Diagnostic trouble code “P1730 A/T INTERLOCK” with CONSULT-II or 12th judgement flicker without CONSULT-II is detected when TCM does not receive the proper voltage signal from the sensor and switch.
- TCM monitors and compares gear position and conditions of each ATF pressure switch when gear is steady.

### Possible Cause

UCS00454

- Harness or connectors  
(The solenoid and switch circuit is open or shorted.)
- Low coast brake solenoid valve
- ATF pressure switch 2

### DTC Confirmation Procedure

UCS00455

#### NOTE:

If “DTC Confirmation Procedure” has been previously performed, always turn ignition switch “OFF” and wait at least 10 seconds before performing the next test.

After the repair, perform the following procedure to confirm the malfunction is eliminated.

#### WITH CONSULT-II

1. Turn ignition switch “ON”. (Do not start engine.)
2. Select “DATA MONITOR” mode for “A/T” with CONSULT-II.
3. Start engine.
4. Drive vehicle and maintain the following conditions for at least 2 consecutive seconds.  
**Selector lever: “D” position**
5. If DTC is detected, go to [AT-136, "Diagnostic Procedure"](#) .

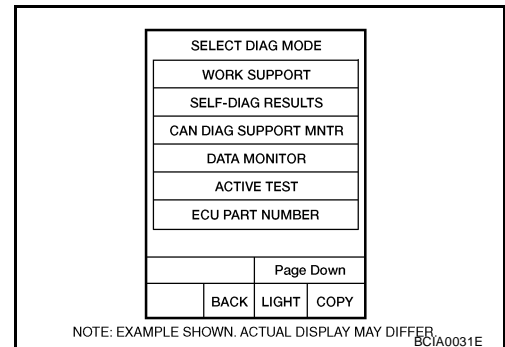

#### WITH GST

Follow the procedure “WITH CONSULT-II”.

# DTC P1730 A/T INTERLOCK

UCS00456

## Judgement of A/T Interlock

When A/T Interlock is judged to be malfunctioning, the vehicle should be fixed in 2nd gear, and should be set in a condition in which it can travel.

When one of the following fastening patterns is detected, the fail-safe function in correspondence with the individual pattern should be performed.

### NOTE:

**When the vehicle is driven in 2nd gear, a turbine revolution sensor malfunction is displayed, but this is not a turbine revolution sensor malfunction.**

## A/T INTERLOCK COUPLING PATTERN TABLE

●: NG, X: OK

Gear position		ATF pressure switch output					Fail-safe function	Clutch pressure output pattern after fail-safe function					
		SW3 (I/C)	SW6 (HLR/C)	SW5 (D/C)	SW1 (FR/B)	SW2 (LC/B)		I/C	HLR/C	D/C	FR/B	LC/B	L/U
A/T interlock coupling pattern	3rd	–	X	X	–	●	Held in 2nd gear	OFF	OFF	ON	OFF	OFF	OFF
	4th	–	X	X	–	●	Held in 2nd gear	OFF	OFF	ON	OFF	OFF	OFF
	5th	X	X	–	X	●	Held in 2nd gear	OFF	OFF	ON	OFF	OFF	OFF

## Diagnostic Procedure

UCS00457

### 1. SELF-DIAGNOSIS

#### ④ With CONSULT-II

1. Drive vehicle.
2. Stop vehicle and turn ignition switch OFF.
3. Turn ignition switch ON.
4. Select "SELF-DIAG RESULTS" mode for "A/T" with CONSULT-II.

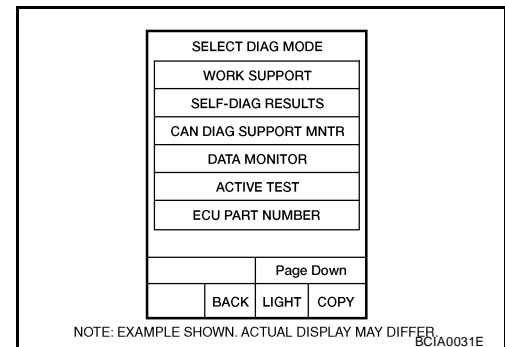

#### ④ Without CONSULT-II

1. Drive vehicle.
2. Stop vehicle and turn ignition switch OFF.
3. Turn ignition switch ON.
4. Perform self-diagnosis. Refer to [AT-96, "TCM SELF-DIAGNOSTIC PROCEDURE \(NO TOOLS\)"](#) .

#### OK or NG

OK >> GO TO 2.

NG >> Check low coast brake solenoid valve circuit and function. Refer to [AT-156, "DTC P1772 LOW COAST BRAKE SOLENOID VALVE"](#) , [AT-158, "DTC P1774 LOW COAST BRAKE SOLENOID VALVE FUNCTION"](#) .



# DTC P1730 A/T INTERLOCK

---

## 2. CHECK DTC

---

Perform "DTC Confirmation Procedure".

- Refer to [AT-135, "DTC Confirmation Procedure"](#).

OK or NG

- OK >> **INSPECTION END**
- NG >> GO TO 3.

---

## 3. CHECK TCM POWER SUPPLY AND GROUND CIRCUIT

---

Check TCM power supply and ground circuit. Refer to [AT-168, "MAIN POWER SUPPLY AND GROUND CIRCUIT"](#).

OK or NG

- OK >> GO TO 4.
- NG >> Repair or replace damaged parts.

---

## 4. DETECT MALFUNCTIONING ITEM

---

Check the following.

- The A/T assembly harness connector pin terminals for damage or loose connection with harness connector.

OK or NG

- OK >> Replace the control valve with TCM. Refer to [AT-228, "Control Valve With TCM and A/T Fluid Temperature Sensor 2"](#).
- NG >> Repair or replace damaged parts.

A  
B  
AT  
D  
E  
F  
G  
H  
I  
J  
K  
L  
M

# DTC P1731 A/T 1ST ENGINE BRAKING

## DTC P1731 A/T 1ST ENGINE BRAKING

PF:00000

### Description

UCS00458

Fail-safe function to prevent sudden decrease in speed by engine brake other than at "1" position.

### CONSULT-II Reference Value

UCS00459

Item name	Condition	Display value
ON OFF SOL	Low coast brake engaged. Refer to <a href="#">AT-21</a> .	ON
	Low coast brake disengaged. Refer to <a href="#">AT-21</a> .	OFF
ATF PRES SW 2	Low coast brake engaged. Refer to <a href="#">AT-21</a> .	ON
	Low coast brake disengaged. Refer to <a href="#">AT-21</a> .	OFF

### On Board Diagnosis Logic

UCS0045A

- This is not an OBD-II self-diagnostic item.
- Diagnostic trouble code "P1731 A/T 1ST E/BRAKING" with CONSULT-II or 13th judgement flicker without CONSULT-II is detected under the following conditions.
  - When TCM does not receive the proper voltage signal from the sensor.
  - When TCM monitors each ATF pressure switch and solenoid monitor value, and detects as irregular when engine brake of 1st gear acts other than at "1" position.

### Possible Cause

UCS0045B

- Harness or connectors  
(The sensor circuit is open or shorted.)
- Low coast brake solenoid valve
- ATF pressure switch 2

### DTC Confirmation Procedure

UCS0045C

#### NOTE:

If "DTC Confirmation Procedure" has been previously performed, always turn ignition switch "OFF" and wait at least 10 seconds before performing the next test.

After the repair, perform the following procedure to confirm the malfunction is eliminated.

#### WITH CONSULT-II

1. Turn ignition switch "ON". (Do not start engine.)
2. Select "DATA MONITOR" mode for "A/T" with CONSULT-II.
3. Start engine.
4. Drive vehicle and maintain the following conditions for at least 2 consecutive seconds.  
**ENGINE SPEED: 1,200 rpm**  
**Selector lever: "1" position**  
**Gear position: 1st gear**
5. If DTC is detected, go to [AT-139, "Diagnostic Procedure"](#) .

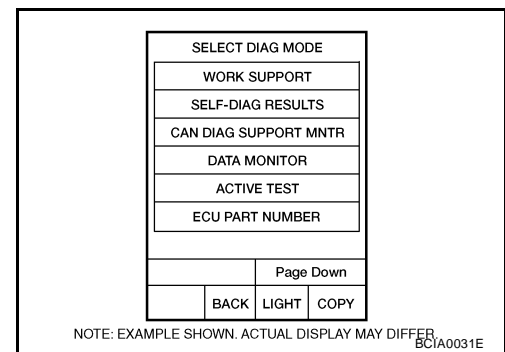

# DTC P1731 A/T 1ST ENGINE BRAKING

UCS0045D

## Diagnostic Procedure

### 1. CHECK INPUT SIGNALS

#### With CONSULT-II

1. Start the engine.
2. Select "SELECTION FROM MENU" in "DATA MONITOR" mode for "A/T" with CONSULT-II.
3. Drive vehicle in the "1" position (1st gear), and confirm the ON/OFF actuation of "ATF PRES SW 2" and "ON OFF SOL".

#### OK or NG

- OK >> GO TO 4.  
NG >> GO TO 2.

DATA MONITOR			
MONITOR		NO DTC	
ATF PRES SW 2		xxx	
ON OFF SOL		xxx	
		RECORD	
MODE	BACK	LIGHT	COPY

SCIA4670E

### 2. CHECK TCM POWER SUPPLY AND GROUND CIRCUIT

Check TCM power supply and ground circuit. Refer to [AT-168, "MAIN POWER SUPPLY AND GROUND CIRCUIT"](#).

#### OK or NG

- OK >> GO TO 3.  
NG >> Repair or replace damaged parts.

### 3. DETECT MALFUNCTIONING ITEM

Check the following.

- The A/T assembly harness connector pin terminals for damage or loose connection with harness connector.

#### OK or NG

- OK >> Replace the control valve with TCM. Refer to [AT-228, "Control Valve With TCM and A/T Fluid Temperature Sensor 2"](#).
- NG >> Repair or replace damaged parts.

### 4. CHECK DTC

Perform "DTC Confirmation Procedure".

- Refer to [AT-138, "DTC Confirmation Procedure"](#).

#### OK or NG

- OK >> **INSPECTION END**  
NG >> GO TO 2.

# DTC P1752 INPUT CLUTCH SOLENOID VALVE

## DTC P1752 INPUT CLUTCH SOLENOID VALVE

PF3:31940

### Description

UCS0045E

Input clutch solenoid valve is controlled by the TCM in response to signals sent from the PNP switch, vehicle speed sensor and accelerator pedal position sensor (throttle position sensor). Gears will then be shifted to the optimum position.

### CONSULT-II Reference Value

UCS0045F

Item name	Condition	Display value (Approx.)
I/C SOLENOID	Input clutch disengaged. Refer to <a href="#">AT-21</a> .	0.6 - 0.8 A
	Input clutch engaged. Refer to <a href="#">AT-21</a> .	0 - 0.05 A

### On Board Diagnosis Logic

UCS0045G

- This is an OBD-II self-diagnostic item.
- Diagnostic trouble code "P1752 I/C SOLENOID/CIRC" with CONSULT-II or 5th judgement flicker without CONSULT-II is detected under the following conditions.
  - When TCM detects an improper voltage drop when it tries to operate the solenoid valve.
  - When TCM detects as irregular by comparing target value with monitor value.

### Possible Cause

UCS0045H

- Harness or connectors  
(The solenoid circuit is open or shorted.)
- Input clutch solenoid valve

### DTC Confirmation Procedure

UCS0045I

#### CAUTION:

Always drive vehicle at a safe speed.

#### NOTE:

If "DTC Confirmation Procedure" has been previously performed, always turn ignition switch "OFF" and wait at least 10 seconds before performing the next test.

After the repair, perform the following procedure to confirm the malfunction is eliminated.

#### ④ WITH CONSULT-II

1. Turn ignition switch "ON". (Do not start engine.)
2. Select "DATA MONITOR" mode for "A/T" with CONSULT-II.
3. Start engine.
4. Drive vehicle and maintain the following conditions for at least 5 consecutive seconds.

**ACCELE POS: 1.5/8 - 2.0/8**

**Selector lever: "D" position**

**Gear position: 3rd ⇒ 4th Gear (I/C ON/OFF)**

**Driving location: Driving the vehicle uphill (increased engine load) will help maintain the driving conditions required for this test.**

5. If DTC is detected go to [AT-141, "Diagnostic Procedure"](#) .

#### ④ WITH GST

Follow the procedure "WITH CONSULT-II".

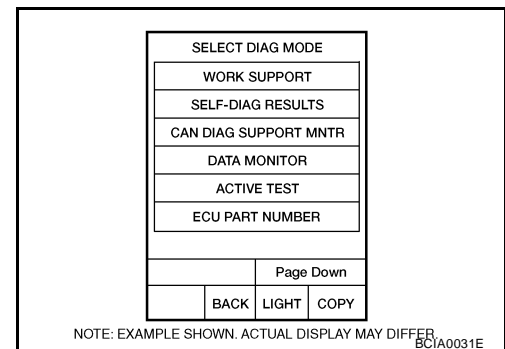

# DTC P1752 INPUT CLUTCH SOLENOID VALVE

UCS0045J

## Diagnostic Procedure

### 1. CHECK INPUT SIGNAL

#### With CONSULT-II

1. Turn ignition switch ON.
2. Select "MAIN SIGNALS" in "DATA MONITOR" mode for "A/T" with CONSULT-II.
3. Start the engine.
4. Read out the value of "I/C SOLENOID" while driving.

DATA MONITOR			
MONITOR		NO DTC	
TCC SOLENOID	XXXX		
LINE PRES SOL	XXXX		
I/C SOLENOID	XXXX		
FR/B SOLENOID	XXXX		
D/C SOLENOID	XXXX		
HLR/C SOL	XXXX		
		▽	
		RECORD	
MODE	BACK	LIGHT	COPY

SCIA4793E

#### OK or NG

- OK >> GO TO 4.  
NG >> GO TO 2.

### 2. CHECK TCM POWER SUPPLY AND GROUND CIRCUIT

Check TCM power supply and ground circuit. Refer to [AT-168, "MAIN POWER SUPPLY AND GROUND CIRCUIT"](#).

#### OK or NG

- OK >> GO TO 3.  
NG >> Repair or replace damaged parts.

### 3. DETECT MALFUNCTIONING ITEM

Check the following.

- The A/T assembly harness connector pin terminals for damage or loose connection with harness connector.

#### OK or NG

- OK >> Replace the control valve with TCM. Refer to [AT-168, "MAIN POWER SUPPLY AND GROUND CIRCUIT"](#).  
NG >> Repair or replace damaged parts.

### 4. CHECK DTC

Perform "DTC Confirmation Procedure".

- Refer to [AT-140, "DTC Confirmation Procedure"](#).

#### OK or NG

- OK >> **INSPECTION END**  
NG >> GO TO 2.

# DTC P1754 INPUT CLUTCH SOLENOID VALVE FUNCTION

## DTC P1754 INPUT CLUTCH SOLENOID VALVE FUNCTION

PF3:31940

### Description

UCS0045K

- Input clutch solenoid valve is controlled by the TCM in response to signals sent from the PNP switch, vehicle speed sensor and accelerator pedal position sensor (throttle position sensor). Gears will then be shifted to the optimum position.
- This is not only caused by electrical malfunction (circuits open or shorted) but also by mechanical malfunction such as control valve sticking, improper solenoid valve operation.

### CONSULT-II Reference Value

UCS0045L

Item name	Condition	Display value (Approx.)
I/C SOLENOID	Input clutch disengaged. Refer to <a href="#">AT-21</a> .	0.6 - 0.8 A
	Input clutch engaged. Refer to <a href="#">AT-21</a> .	0 - 0.05 A
ATF PRES SW 3	Input clutch engaged. Refer to <a href="#">AT-21</a> .	ON
	Input clutch disengaged. Refer to <a href="#">AT-21</a> .	OFF

### On Board Diagnosis Logic

UCS0045M

- This is an OBD-II self-diagnostic item.
- Diagnostic trouble code "P1754 I/C SOLENOID FNCTN" with CONSULT-II or 5th judgement flicker without CONSULT-II is detected under the following conditions.
  - When TCM detects that actual gear ratio is irregular, and relation between gear position and condition of pressure switch 3 is irregular during depressing accelerator pedal. (Other than during shift change)
  - When TCM detects that relation between gear position and condition of ATF pressure switch 3 is irregular during releasing accelerator pedal. (Other than during shift change)

### Possible Cause

UCS0045N

- Harness or connectors  
(The solenoid and switch circuits are open or shorted.)
- Input clutch solenoid valve
- ATF pressure switch 3

### DTC Confirmation Procedure

UCS0045O

#### CAUTION:

Always drive vehicle at a safe speed.

#### NOTE:

If "DTC Confirmation Procedure" has been previously performed, always turn ignition switch "OFF" and wait at least 10 seconds before performing the next test.

After the repair, perform the following procedure to confirm the malfunction is eliminated.

#### WITH CONSULT-II

1. Start engine.
2. Accelerate vehicle to maintain the following conditions.  
**ACCELE POSI: 1.5/8 - 2.0/8**  
**Selector lever: "D" position**  
**Gear position: 3rd ⇒ 4th Gear (I/C ON/OFF)**  
**Driving location: Driving the vehicle uphill (increased engine load) will help maintain the driving conditions required for this test.**
3. Perform step "2" again.
4. Turn ignition switch "OFF", then perform step "1" to "3" again.
5. Check "SELF-DIAG RESULTS" mode for "A/T" with CONSULT-II. If DTC (P1754) is detected, refer to [AT-143, "Diagnostic Procedure"](#) .  
If DTC (P1752) is detected, go to [AT-141, "Diagnostic Procedure"](#) .  
If DTC (P1843) is detected, go to [AT-163, "Diagnostic Procedure"](#) .

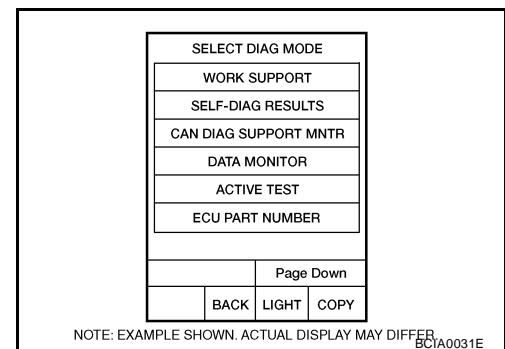

# DTC P1754 INPUT CLUTCH SOLENOID VALVE FUNCTION

## WITH GST

Follow the procedure "WITH CONSULT-II".

### Diagnostic Procedure

UCS0045P

#### 1. CHECK INPUT SIGNALS

##### With CONSULT-II

1. Start engine.
2. Select "SELECTION FROM MENU" in "DATA MONITOR" mode for "A/T" with CONSULT-II.
3. Drive vehicle in "D" position (3rd ⇒ 4th gear), and confirm the ON/OFF actuation of "ATF PRES SW 3" and electrical current value of "I/C SOLENOID".

##### OK or NG

- OK >> GO TO 4.  
NG >> GO TO 2.

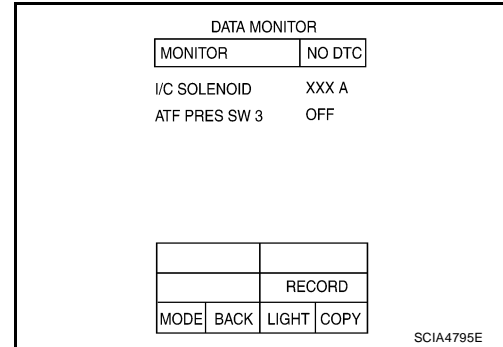

#### 2. CHECK TCM POWER SUPPLY AND GROUND CIRCUIT

Check TCM power supply and ground circuit. Refer to [AT-168, "MAIN POWER SUPPLY AND GROUND CIRCUIT"](#).

##### OK or NG

- OK >> GO TO 3.  
NG >> Repair or replace damaged parts.

#### 3. DETECT MALFUNCTIONING ITEM

Check the following.

- The A/T assembly harness connector pin terminals for damage or loose connection with harness connector.

##### OK or NG

- OK >> Replace the control valve with TCM. Refer to [AT-228, "Control Valve With TCM and A/T Fluid Temperature Sensor 2"](#).
- NG >> Repair or replace damaged parts.

#### 4. CHECK DTC

Perform "DTC Confirmation Procedure".

- Refer to [AT-142, "DTC Confirmation Procedure"](#).

##### OK or NG

- OK >> **INSPECTION END**  
NG >> GO TO 2.

# DTC P1757 FRONT BRAKE SOLENOID VALVE

## DTC P1757 FRONT BRAKE SOLENOID VALVE

PF3:31940

### Description

UCS0045Q

Front brake solenoid valve is controlled by the TCM in response to signals sent from the PNP switch, vehicle speed sensor and accelerator pedal position sensor (throttle position sensor). Gears will then be shifted to the optimum position.

### CONSULT-II Reference Value

UCS0045R

Item name	Condition	Display value (Approx.)
FR/B SOLENOID	Front brake engaged. Refer to <a href="#">AT-21</a> .	0.6 - 0.8 A
	Front brake disengaged. Refer to <a href="#">AT-21</a> .	0 - 0.05 A

### On Board Diagnosis Logic

UCS0045S

- This is an OBD-II self-diagnostic item.
- Diagnostic trouble code “P1757 FR/B SOLENOID/CIRC” with CONSULT-II or 6th judgement flicker without CONSULT-II is detected under the following conditions.
  - When TCM detects an improper voltage drop when it tries to operate the solenoid valve.
  - When TCM detects as irregular by comparing target value with monitor value.

### Possible Cause

UCS0045T

- Harness or connectors  
(The solenoid circuit is open or shorted.)
- Front brake solenoid valve

### DTC Confirmation Procedure

UCS0045U

#### CAUTION:

Always drive vehicle at a safe speed.

#### NOTE:

If “DTC Confirmation Procedure” has been previously performed, always turn ignition switch “OFF” and wait at least 10 seconds before performing the next test.

After the repair, perform the following procedure to confirm the malfunction is eliminated.

#### ④ WITH CONSULT-II

1. Turn ignition switch “ON”. (Do not start engine.)
2. Select “DATA MONITOR” mode for “A/T” with CONSULT-II.
3. Start engine.
4. Drive vehicle and maintain the following conditions for at least 5 consecutive seconds.

**ACCELE POS: 1.5/8 - 2.0/8**

**Selector lever: “D” position**

**Gear position: 3rd ⇒ 4th Gear (FR/B ON/OFF)**

**Driving location: Driving the vehicle uphill (increased engine load) will help maintain the driving conditions required for this test.**

5. If DTC is detected go to [AT-145, "Diagnostic Procedure"](#) .

#### ④ WITH GST

Follow the procedure “WITH CONSULT-II”.

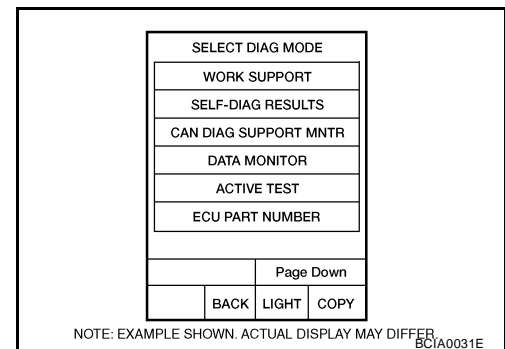



# DTC P1757 FRONT BRAKE SOLENOID VALVE

UCS0045V

## Diagnostic Procedure

### 1. CHECK INPUT SIGNAL

#### With CONSULT-II

1. Turn ignition switch ON.
2. Select "MAIN SIGNALS" in "DATA MONITOR" mode for "A/T" with CONSULT-II.
3. Start engine.
4. Read out the value of "FR/B SOLENOID" while driving.

DATA MONITOR			
MONITOR		NO DTC	
TCC SOLENOID	XXXX		
LINE PRES SOL	XXXX		
I/C SOLENOID	XXXX		
FR/B SOLENOID	XXXX		
D/C SOLENOID	XXXX		
HLR/C SOL	XXXX		
			▽
			RECORD
MODE	BACK	LIGHT	COPY

SCIA4793E

#### OK or NG

- OK >> GO TO 4.  
NG >> GO TO 2.

### 2. CHECK TCM POWER SUPPLY AND GROUND CIRCUIT

Check TCM power supply and ground circuit. Refer to [AT-168, "MAIN POWER SUPPLY AND GROUND CIRCUIT"](#).

#### OK or NG

- OK >> GO TO 3.  
NG >> Repair or replace damaged parts.

### 3. DETECT MALFUNCTIONING ITEM

Check the following.

- The A/T assembly harness connector pin terminals for damage or loose connection with harness connector.

#### OK or NG

- OK >> Replace the control valve with TCM. Refer to [AT-228, "Control Valve With TCM and A/T Fluid Temperature Sensor 2"](#).
- NG >> Repair or replace damaged parts.

### 4. CHECK DTC

Perform "DTC Confirmation Procedure".

- Refer to [AT-144, "DTC Confirmation Procedure"](#).

#### OK or NG

- OK >> **INSPECTION END**  
NG >> GO TO 2.

# DTC P1759 FRONT BRAKE SOLENOID VALVE FUNCTION

## DTC P1759 FRONT BRAKE SOLENOID VALVE FUNCTION

PF:31940

### Description

UCS0045W

- Front brake solenoid valve is controlled by the TCM in response to signals sent from the PNP switch, vehicle speed sensor and accelerator pedal position sensor (throttle position sensor). Gears will then be shifted to the optimum position.
- This is not only caused by electrical malfunction (circuits open or shorted) but also by mechanical malfunction such as control valve sticking, improper solenoid valve operation.

### CONSULT-II Reference Value

UCS0045X

Item name	Condition	Display value (Approx.)
FR/B SOLENOID	Front brake engaged. Refer to <a href="#">AT-21</a> .	0.6 - 0.8 A
	Front brake disengaged. Refer to <a href="#">AT-21</a> .	0 - 0.05 A
ATF PRES SW 1	Front brake engaged. Refer to <a href="#">AT-21</a> .	ON
	Front brake disengaged. Refer to <a href="#">AT-21</a> .	OFF

### On Board Diagnosis Logic

UCS0045Y

- This is an OBD-II self-diagnostic item.
- Diagnostic trouble code "P1759 FR/B SOLENOID FNCT" with CONSULT-II or 6th judgement flicker without CONSULT-II is detected under the following conditions.
  - When TCM detects that actual gear ratio is irregular, and relation between gear position and condition of ATF pressure switch 1 is irregular during depressing accelerator pedal. (Other than during shift change)
  - When TCM detects that relation between gear position and condition of ATF pressure switch 1 is irregular during releasing accelerator pedal. (Other than during shift change)

### Possible Cause

UCS0045Z

- Harness or connectors  
(The solenoid and switch circuits are open or shorted.)
- Front brake solenoid valve
- ATF pressure switch 1

### DTC Confirmation Procedure

UCS00460

#### CAUTION:

Always drive vehicle at a safe speed.

#### NOTE:

If "DTC Confirmation Procedure" has been previously performed, always turn ignition switch "OFF" and wait at least 10 seconds before performing the next test.

After the repair, perform the following procedure to confirm the malfunction is eliminated.

#### WITH CONSULT-II

1. Start engine.
2. Accelerate vehicle to maintain the following conditions.  
**ACCELE POS: 1.5/8 - 2.0/8**  
**Selector lever: "D" position**  
**Gear position: 3rd ⇒ 4th Gear (FR/B ON/OFF)**  
**Driving location: Driving the vehicle uphill (increased engine load) will help maintain the driving conditions required for this test.**
3. Perform step "2" again.
4. Turn ignition switch "OFF", then perform step "1" to "3" again.
5. Check "SELF-DIAG RESULTS" mode for "A/T" with CONSULT-II. If DTC (P1759) is detected, refer to [AT-147, "Diagnostic Procedure"](#) .  
If DTC (P1757) is detected, go to [AT-145, "Diagnostic Procedure"](#) .  
If DTC (P1841) is detected, go to [AT-161, "Diagnostic Procedure"](#) .

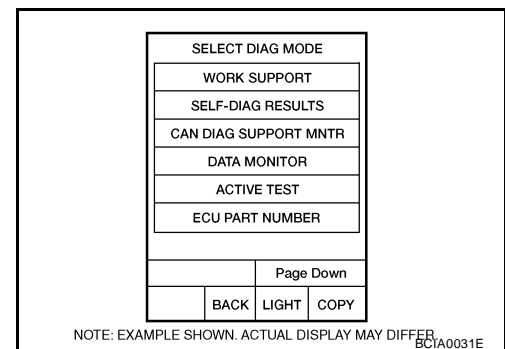

# DTC P1759 FRONT BRAKE SOLENOID VALVE FUNCTION

## WITH GST

Follow the procedure "WITH CONSULT-II".

### Diagnostic Procedure

UCS00461

#### 1. CHECK INPUT SIGNALS

##### With CONSULT-II

1. Start engine.
2. Select "SELECTION FROM MENU" in "DATA MONITOR" mode for "A/T" with CONSULT-II.
3. Drive vehicle in the "D" position (3rd ⇒ 4th gear), and confirm the ON/OFF actuation of the "ATF PRES SW 1" and electrical current value of "FR/B SOLENOID".

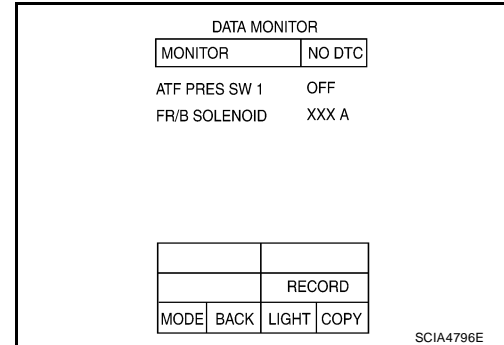

##### OK or NG

- OK >> GO TO 4.  
NG >> GO TO 2.

#### 2. CHECK TCM POWER SUPPLY AND GROUND CIRCUIT

Check TCM power supply and ground circuit. Refer to [AT-168, "MAIN POWER SUPPLY AND GROUND CIRCUIT"](#).

##### OK or NG

- OK >> GO TO 3.  
NG >> Repair or replace damaged parts.

#### 3. DETECT MALFUNCTIONING ITEM

Check the following.

- The A/T assembly harness connector pin terminals for damage or loose connection with harness connector.

##### OK or NG

- OK >> Replace the control valve with TCM. Refer to [AT-228, "Control Valve With TCM and A/T Fluid Temperature Sensor 2"](#).
- NG >> Repair or replace damaged parts.

#### 4. CHECK DTC

Perform "DTC Confirmation Procedure".

- Refer to [AT-146, "DTC Confirmation Procedure"](#).

##### OK or NG

- OK >> **INSPECTION END**  
NG >> GO TO 2.

# DTC P1762 DIRECT CLUTCH SOLENOID VALVE

## DTC P1762 DIRECT CLUTCH SOLENOID VALVE

PF3:31940

### Description

UCS00462

Direct clutch solenoid valve is controlled by the TCM in response to signals sent from the PNP switch, vehicle speed sensor and accelerator pedal position sensor (throttle position sensor). Gears will then be shifted to the optimum position.

### CONSULT-II Reference Value

UCS00463

Item name	Condition	Display value (Approx.)
D/C SOLENOID	Direct clutch disengaged. Refer to <a href="#">AT-21</a> .	0.6 - 0.8 A
	Direct clutch engaged. Refer to <a href="#">AT-21</a> .	0 - 0.05 A

### On Board Diagnosis Logic

UCS00464

- This is an OBD-II self-diagnostic item.
- Diagnostic trouble code “P1762 D/C SOLENOID/CIRC” with CONSULT-II or 2nd judgement flicker without CONSULT-II is detected under the following conditions.
  - When TCM detects an improper voltage drop when it tries to operate the solenoid valve.
  - When TCM detects as irregular by comparing target value with monitor value.

### Possible Cause

UCS00465

- Harness or connectors  
(The solenoid circuit is open or shorted.)
- Direct clutch solenoid valve

### DTC Confirmation Procedure

UCS00466

#### NOTE:

If “DTC Confirmation Procedure” has been previously performed, always turn ignition switch “OFF” and wait at least 10 seconds before performing the next test.

After the repair, perform the following procedure to confirm the malfunction is eliminated.

#### WITH CONSULT-II

1. Turn ignition switch “ON”. (Do not start engine.)
2. Select “DATA MONITOR” mode for “A/T” with CONSULT-II.
3. Start engine.
4. Drive vehicle and maintain the following conditions for at least 5 consecutive seconds.  
**ACCELE POS: 1.5/8 - 2.0/8**  
**Selector lever: “D” position**  
**Gear position: 1st ⇒ 2nd Gear (D/C ON/OFF)**  
**Driving location: Driving the vehicle uphill (increased engine load) will help maintain the driving conditions required for this test.**
5. If DTC is detected, go to [AT-149, "Diagnostic Procedure"](#) .

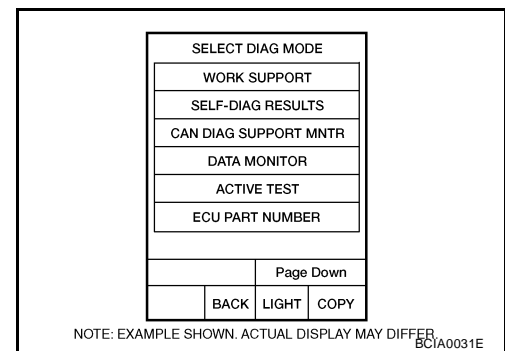

#### WITH GST

Follow the procedure “WITH CONSULT-II”.

# DTC P1762 DIRECT CLUTCH SOLENOID VALVE

UCS00467

## Diagnostic Procedure

### 1. CHECK INPUT SIGNAL

#### With CONSULT-II

1. Turn ignition switch ON.
2. Select "MAIN SIGNALS" in "DATA MONITOR" mode for "A/T" with CONSULT-II.
3. Start the engine.
4. Read out the value of "D/C SOLENOID" while driving.

DATA MONITOR			
MONITOR		NO DTC	
TCC SOLENOID		XXXX	
LINE PRES SOL		XXXX	
I/C SOLENOID		XXXX	
FR/B SOLENOID		XXXX	
D/C SOLENOID		XXXX	
HLR/C SOL		XXXX	
		▽	
		RECORD	
MODE	BACK	LIGHT	COPY

SCIA4793E

#### OK or NG

- OK >> GO TO 4.  
NG >> GO TO 2.

### 2. CHECK TCM POWER SUPPLY AND GROUND CIRCUIT

Check TCM power supply and ground circuit. Refer to [AT-168, "MAIN POWER SUPPLY AND GROUND CIRCUIT"](#).

#### OK or NG

- OK >> GO TO 3.  
NG >> Repair or replace damaged parts.

### 3. DETECT MALFUNCTIONING ITEM

Check the following.

- The A/T assembly harness connector pin terminals for damage or loose connection with harness connector.

#### OK or NG

- OK >> Replace the control valve with TCM. Refer to [AT-228, "Control Valve With TCM and A/T Fluid Temperature Sensor 2"](#).
- NG >> Repair or replace damaged parts.

### 4. CHECK DTC

Perform "DTC Confirmation Procedure".

- Refer to [AT-148, "DTC Confirmation Procedure"](#).

#### OK or NG

- OK >> **INSPECTION END**  
NG >> GO TO 2.

# DTC P1764 DIRECT CLUTCH SOLENOID VALVE FUNCTION

## DTC P1764 DIRECT CLUTCH SOLENOID VALVE FUNCTION

PF3:31940

### Description

UCS00468

- Direct clutch solenoid valve is controlled by the TCM in response to signals sent from the PNP switch, vehicle speed sensor and accelerator pedal position sensor (throttle position sensor). Gears will then be shifted to the optimum position.
- This is not only caused by electrical malfunction (circuits open or shorted) but also by mechanical malfunction such as control valve sticking, improper solenoid valve operation.

### CONSULT-II Reference Value

UCS00469

Item name	Condition	Display value (Approx.)
D/C SOLENOID	Direct clutch disengaged. Refer to <a href="#">AT-21</a> .	0.6 - 0.8 A
	Direct clutch engaged. Refer to <a href="#">AT-21</a> .	0 - 0.05 A
ATF PRES SW 5	Direct clutch engaged. Refer to <a href="#">AT-21</a> .	ON
	Direct clutch disengaged. Refer to <a href="#">AT-21</a> .	OFF

### On Board Diagnosis Logic

UCS0046A

- This is an OBD-II self-diagnostic item.
- Diagnostic trouble code “P1764 D/C SOLENOID FNCTN” with CONSULT-II or 2nd judgement flicker without CONSULT-II is detected under the following conditions.
  - When TCM detects that actual gear ratio is irregular, and relation between gear position and condition of ATF pressure switch 5 is irregular during depressing accelerator pedal. (Other than during shift change)
  - When TCM detects that relation between gear position and condition of ATF pressure switch 5 is irregular during releasing accelerator pedal. (Other than during shift change)

### Possible Cause

UCS0046B

- Harness or connectors  
(The solenoid and switch circuits are open or shorted.)
- Direct clutch solenoid valve
- ATF pressure switch 5

### DTC Confirmation Procedure

UCS0046C

#### NOTE:

If “DTC Confirmation Procedure” has been previously performed, always turn ignition switch “OFF” and wait at least 10 seconds before performing the next test.

After the repair, perform the following procedure to confirm the malfunction is eliminated.

#### WITH CONSULT-II

1. Start engine.
2. Accelerate vehicle to maintain the following conditions.  
**ACCELE POS: 1.5/8 - 2.0/8**  
**Selector lever: “D” position**  
**Gear position: 1st ⇒ 2nd Gear (D/C ON/OFF)**  
**Driving location: Driving the vehicle uphill (increased engine load) will help maintain the driving conditions required for this test.**
3. Perform step “2” again.
4. Turn ignition switch “OFF”, then perform step “1” to “3” again.
5. Check “SELF-DIAG RESULTS” mode for “A/T” with CONSULT-II. If DTC (P1764) is detected, refer to [AT-151, "Diagnostic Procedure"](#) .  
If DTC (P1762) is detected, go to [AT-149, "Diagnostic Procedure"](#) .  
If DTC (P1845) is detected, go to [AT-165, "Diagnostic Procedure"](#) .

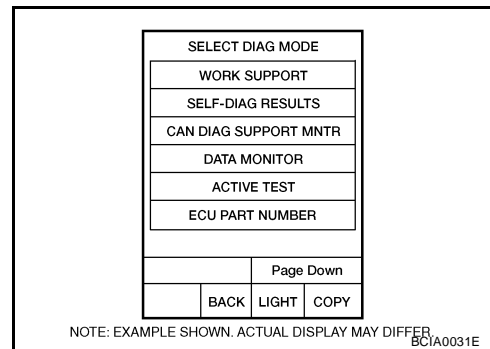

#### WITH GST

Follow the procedure “WITH CONSULT-II”.

# DTC P1764 DIRECT CLUTCH SOLENOID VALVE FUNCTION

UCS0046D

## Diagnostic Procedure

### 1. CHECK INPUT SIGNALS

#### With CONSULT-II

1. Start engine.
2. Select "SELECTION FROM MENU" in "DATA MONITOR" mode for "A/T" with CONSULT-II.
3. Drive vehicle in the "D" position (1st ⇒ 2nd gear), and confirm the display actuation of the "ATF PRES SW 5" and electrical current value of "D/C SOLENOID".

DATA MONITOR			
MONITOR		NO DTC	
D/C SOLENOID		XXXX	
ATF PRES SW 5		OFF	
		RECORD	
MODE	BACK	LIGHT	COPY

SCIA4797E

#### OK or NG

- OK >> GO TO 4.  
NG >> GO TO 2.

### 2. CHECK TCM POWER SUPPLY AND GROUND CIRCUIT

Check TCM power supply and ground circuit. Refer to [AT-168, "MAIN POWER SUPPLY AND GROUND CIRCUIT"](#).

#### OK or NG

- OK >> GO TO 3.  
NG >> Repair or replace damaged parts.

### 3. DETECT MALFUNCTIONING ITEM

Check the following.

- The A/T assembly harness connector pin terminals for damage or loose connection with harness connector.

#### OK or NG

- OK >> Replace the control valve with TCM. Refer to [AT-228, "Control Valve With TCM and A/T Fluid Temperature Sensor 2"](#).
- NG >> Repair or replace damaged parts.

### 4. CHECK DTC

Perform "DTC Confirmation Procedure".

- Refer to [AT-150, "DTC Confirmation Procedure"](#).

#### OK or NG

- OK >> **INSPECTION END**  
NG >> GO TO 2.

# DTC P1767 HIGH AND LOW REVERSE CLUTCH SOLENOID VALVE

## DTC P1767 HIGH AND LOW REVERSE CLUTCH SOLENOID VALVE

PF:31940

### Description

UCS0046E

High and low reverse clutch solenoid valve is controlled by the TCM in response to signals sent from the PNP switch, vehicle speed sensor and accelerator pedal position sensor (throttle position sensor). Gears will then be shifted to the optimum position.

### CONSULT-II Reference Value

UCS0046F

Item name	Condition	Display value (Approx.)
HLR/C SOL	High and low reverse clutch disengaged. Refer to <a href="#">AT-21</a> .	0.6 - 0.8 A
	High and low reverse clutch engaged. Refer to <a href="#">AT-21</a> .	0 - 0.05 A

### On Board Diagnosis Logic

UCS0046G

- This is an OBD-II self-diagnostic item.
- Diagnostic trouble code “P1767 HLR/C SOL/CIRC” with CONSULT-II or 8th judgement flicker without CONSULT-II is detected under the following conditions.
  - When TCM detects an improper voltage drop when it tries to operate the solenoid valve.
  - When TCM detects as irregular by comparing target value with monitor value.

### Possible Cause

UCS0046H

- Harness or connectors  
(The solenoid circuit is open or shorted.)
- High and low reverse clutch solenoid valve

### DTC Confirmation Procedure

UCS0046I

#### CAUTION:

Always drive vehicle at a safe speed.

#### NOTE:

If “DTC Confirmation Procedure” has been previously performed, always turn ignition switch “OFF” and wait at least 10 seconds before performing the next test.

After the repair, perform the following procedure to confirm the malfunction is eliminated.

#### WITH CONSULT-II

1. Turn ignition switch “ON”. (Do not start engine.)
2. Select “DATA MONITOR” mode for “A/T” with CONSULT-II.
3. Start engine.
4. Drive vehicle and maintain the following conditions for at least 5 consecutive seconds.

**ACCELE POS: 1.5/8 - 2.0/8**

**Selector lever: “D” position**

**Gear position: 2nd ⇒ 3rd Gear (HLR/C ON/OFF)**

**Driving location: Driving the vehicle uphill (increased engine load) will help maintain the driving conditions required for this test.**

5. If DTC is detected, go to [AT-153, "Diagnostic Procedure"](#) .

#### WITH GST

Follow the procedure “WITH CONSULT-II”.

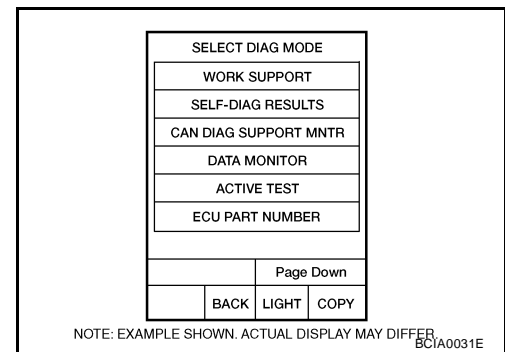



# DTC P1767 HIGH AND LOW REVERSE CLUTCH SOLENOID VALVE

UCS0046J

## Diagnostic Procedure

### 1. CHECK INPUT SIGNAL

#### With CONSULT-II

1. Turn ignition switch ON.
2. Select "MAIN SIGNALS" in "DATA MONITOR" mode for "A/T" with CONSULT-II.
3. Start the engine.
4. Read out the value of "HLR/C SOLENOID" while driving.

DATA MONITOR			
MONITOR		NO DTC	
TCC SOLENOID	XXXX		
LINE PRES SOL	XXXX		
I/C SOLENOID	XXXX		
FR/B SOLENOID	XXXX		
D/C SOLENOID	XXXX		
HLR/C SOL	XXXX		
			▽
			RECORD
MODE	BACK	LIGHT	COPY

SCIA4793E

#### OK or NG

- OK >> GO TO 4.  
NG >> GO TO 2.

### 2. CHECK TCM POWER SUPPLY AND GROUND CIRCUIT

Check TCM power supply and ground circuit. Refer to [AT-168, "MAIN POWER SUPPLY AND GROUND CIRCUIT"](#).

#### OK or NG

- OK >> GO TO 3.  
NG >> Repair or replace damaged parts.

### 3. DETECT MALFUNCTIONING ITEM

Check the following.

- The A/T assembly harness connector pin terminals for damage or loose connection with harness connector.

#### OK or NG

- OK >> Replace the control valve with TCM. Refer to [AT-228, "Control Valve With TCM and A/T Fluid Temperature Sensor 2"](#).
- NG >> Repair or replace damaged parts.

### 4. CHECK DTC

Perform "DTC Confirmation Procedure".

- Refer to [AT-152, "DTC Confirmation Procedure"](#).

#### OK or NG

- OK >> **INSPECTION END**  
NG >> GO TO 2.

# DTC P1769 HIGH AND LOW REVERSE CLUTCH SOLENOID VALVE FUNCTION

## DTC P1769 HIGH AND LOW REVERSE CLUTCH SOLENOID VALVE FUNCTION

PF3:31940

### Description

UCS0046K

- High and low reverse clutch solenoid valve is controlled by the TCM in response to signals sent from the PNP switch, vehicle speed sensor and accelerator pedal position sensor (throttle position sensor). Gears will then be shifted to the optimum position.
- This is not only caused by electrical malfunction (circuits open or shorted) but also by mechanical malfunction such as control valve sticking, improper solenoid valve operation.

### CONSULT-II Reference Value

UCS0046L

Item name	Condition	Display value (Approx.)
HLR/C SOL	High and low reverse clutch disengaged. Refer to <a href="#">AT-21</a> .	0.6 - 0.8 A
	High and low reverse clutch engaged. Refer to <a href="#">AT-21</a> .	0 - 0.05 A
ATF PRES SW 6	High and low reverse clutch engaged. Refer to <a href="#">AT-21</a> .	ON
	High and low reverse clutch disengaged. Refer to <a href="#">AT-21</a> .	OFF

### On Board Diagnosis Logic

UCS0046M

- This is an OBD-II self-diagnostic item.
- Diagnostic trouble code “P1769 HLR/C SOL FNCTN” with CONSULT-II or 8th judgement flicker without CONSULT-II is detected under the following conditions.
  - When TCM detects that actual gear ratio is irregular, and relation between gear position and condition of ATF pressure switch 6 is irregular during depressing accelerator pedal. (Other than during shift change)
  - When TCM detects that relation between gear position and condition of ATF pressure switch 6 is irregular during releasing accelerator pedal. (Other than during shift change)

### Possible Cause

UCS0046N

- Harness or connectors  
(The solenoid and switch circuits are open or shorted.)
- High and low reverse clutch solenoid valve
- ATF pressure switch 6

### DTC Confirmation Procedure

UCS0046O

#### CAUTION:

Always drive vehicle at a safe speed.

#### NOTE:

If “DTC Confirmation Procedure” has been previously performed, always turn ignition switch “OFF” and wait at least 10 seconds before performing the next test.

After the repair, perform the following procedure to confirm the malfunction is eliminated.

#### ④ WITH CONSULT-II

1. Start engine.
2. Accelerate vehicle to maintain the following conditions.  
**ACCELE POS: 1.5/8 - 2.0/8**  
**Selector lever: “D” position**  
**Gear position: 2nd ⇒ 3rd Gear (HLR/C ON/OFF)**  
**Driving location: Driving the vehicle uphill (increased engine load) will help maintain the driving conditions required for this test.**
3. Perform step “2” again.
4. Turn ignition switch “OFF”, then perform step “1” to “3” again.
5. Check “SELF-DIAG RESULTS” mode for “A/T” with CONSULT-II. If DTC (P1769) is detected, refer to [AT-155, "Diagnostic Procedure"](#) .  
If DTC (P1767) is detected, go to [AT-153, "Diagnostic Procedure"](#) .  
If DTC (P1846) is detected, go to [AT-167, "Diagnostic Procedure"](#) .

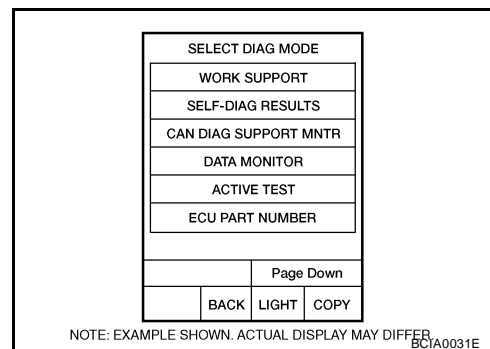

# DTC P1769 HIGH AND LOW REVERSE CLUTCH SOLENOID VALVE FUNCTION

## WITH GST

Follow the procedure "WITH CONSULT-II".

## Diagnostic Procedure

UCS0046P

### 1. CHECK INPUT SIGNALS

#### With CONSULT-II

1. Start the engine.
2. Select "SELECTION FROM MENU" in "DATA MONITOR" mode for "A/T" with CONSULT-II.
3. Drive vehicle in the "D" position (2nd ⇒ 3rd gear), and confirm the ON/OFF actuation of the "ATF PRES SW 6" and electrical current value of "HLR/C SOL".

#### OK or NG

- OK >> GO TO 4.  
NG >> GO TO 2.

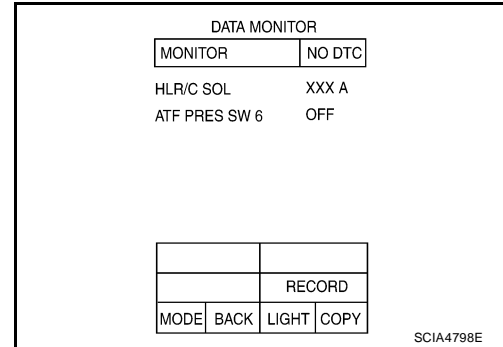

### 2. CHECK TCM POWER SUPPLY AND GROUND CIRCUIT

Check TCM power supply and ground circuit. Refer to [AT-168, "MAIN POWER SUPPLY AND GROUND CIRCUIT"](#).

#### OK or NG

- OK >> GO TO 3.  
NG >> Repair or replace damaged parts.

### 3. DETECT MALFUNCTIONING ITEM

Check the following.

- The A/T assembly harness connector pin terminals for damage or loose connection with harness connector.

#### OK or NG

- OK >> Replace the control valve with TCM. Refer to [AT-228, "Control Valve With TCM and A/T Fluid Temperature Sensor 2"](#).
- NG >> Repair or replace damaged parts.

### 4. CHECK DTC

Perform "DTC Confirmation Procedure".

- Refer to [AT-154, "DTC Confirmation Procedure"](#).

#### OK or NG

- OK >> **INSPECTION END**  
NG >> GO TO 2.

# DTC P1772 LOW COAST BRAKE SOLENOID VALVE

## DTC P1772 LOW COAST BRAKE SOLENOID VALVE

PF3:31940

### Description

UCS0046Q

Low coast brake solenoid valve is turned "ON" or "OFF" by the TCM in response to signals sent from the PNP switch, vehicle speed sensor and accelerator pedal position sensor (throttle position sensor). Gears will then be shifted to the optimum position.

### CONSULT-II Reference Value

UCS0046R

Item name	Condition	Display value
ON OFF SOL	Low coast brake engaged. Refer to <a href="#">AT-21</a> .	ON
	Low coast brake disengaged. Refer to <a href="#">AT-21</a> .	OFF

### On Board Diagnosis Logic

UCS0046S

- This is an OBD-II self-diagnostic item.
- Diagnostic trouble code "P1772 LC/B SOLENOID/CIRC" with CONSULT-II or 7th judgement flicker without CONSULT-II is detected when TCM detects an improper voltage drop when it tries to operate the solenoid valve.

### Possible Cause

UCS0046T

- Harness or connectors  
(The solenoid circuit is open or shorted.)
- Low coast brake solenoid valve

### DTC Confirmation Procedure

UCS0046U

#### NOTE:

If "DTC Confirmation Procedure" has been previously performed, always turn ignition switch "OFF" and wait at least 10 seconds before performing the next test.

After the repair, perform the following procedure to confirm the malfunction is eliminated.

#### WITH CONSULT-II

1. Turn ignition switch "ON". (Do not start engine.)
2. Select "DATA MONITOR" mode for "ENGINE" with CONSULT-II.
3. Start engine.
4. Drive vehicle and maintain the following conditions for at least 5 consecutive seconds.  
**Selector lever: "1" or "2"**  
**Gear position: "1st" or "2nd" gear (LC/B ON/OFF)**
5. If DTC is detected, go to [AT-157, "Diagnostic Procedure"](#) .

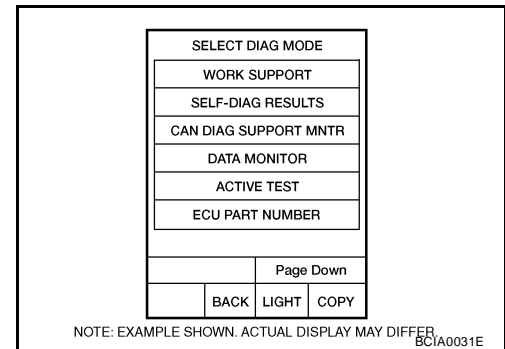

#### WITH GST

Follow the procedure "WITH CONSULT-II".

# DTC P1772 LOW COAST BRAKE SOLENOID VALVE

UCS0046V

## Diagnostic Procedure

### 1. CHECK INPUT SIGNAL

#### With CONSULT-II

1. Turn ignition switch ON.
2. Select "SELECTION FROM MENU" in "DATA MONITOR" mode for "A/T" with CONSULT-II.
3. Start the engine.
4. Read out the value of "ON OFF SOL" while driving.

DATA MONITOR			
MONITOR		NO DTC	
ON OFF SOL		OFF	
ATF PRES SW 2		OFF	
		RECORD	
MODE	BACK	LIGHT	COPY

SCIA4794E

#### OK or NG

- OK >> GO TO 4.  
NG >> GO TO 2.

### 2. CHECK TCM POWER SUPPLY AND GROUND CIRCUIT

Check TCM power supply and ground circuit. Refer to [AT-168, "MAIN POWER SUPPLY AND GROUND CIRCUIT"](#).

#### OK or NG

- OK >> GO TO 3.  
NG >> Repair or replace damaged parts.

### 3. DETECT MALFUNCTIONING ITEM

Check the following.

- The A/T assembly harness connector pin terminals for damage or loose connection with harness connector.

#### OK or NG

- OK >> Replace the control valve with TCM. Refer to [AT-228, "Control Valve With TCM and A/T Fluid Temperature Sensor 2"](#).
- NG >> Repair or replace damaged parts.

### 4. CHECK DTC

Perform "DTC Confirmation Procedure".

- Refer to [AT-156, "DTC Confirmation Procedure"](#).

#### OK or NG

- OK >> **INSPECTION END**  
NG >> GO TO 2.

# DTC P1774 LOW COAST BRAKE SOLENOID VALVE FUNCTION

## DTC P1774 LOW COAST BRAKE SOLENOID VALVE FUNCTION

PFP:31940

### Description

UCS0046W

- Low coast brake solenoid valve is turned “ON” or “OFF” by the TCM in response to signals sent from the PNP switch, vehicle speed sensor and accelerator pedal position sensor (throttle position sensor). Gears will then be shifted to the optimum position.
- This is not only caused by electrical malfunction (circuits open or shorted) but also by mechanical malfunction such as control valve sticking, improper solenoid valve operation.

### CONSULT-II Reference Value

UCS0046X

Item name	Condition	Display value
ON OFF SOL	Low coast brake engaged. Refer to <a href="#">AT-21</a> .	ON
	Low coast brake disengaged. Refer to <a href="#">AT-21</a> .	OFF
ATF PRES SW 2	Low coast brake engaged. Refer to <a href="#">AT-21</a> .	ON
	Low coast brake disengaged. Refer to <a href="#">AT-21</a> .	OFF

### On Board Diagnosis Logic

UCS0046Y

- This is an OBD-II self-diagnostic item.
- Diagnostic trouble code “P1774 LC/B SOLENOID FNCT” with CONSULT-II or 7th judgement flicker without CONSULT-II is detected under the following conditions.
  - When TCM detects that actual gear ratio is irregular, and relation between gear position and condition of ATF pressure switch 2 is irregular during depressing accelerator pedal. (Other than during shift change)
  - When TCM detects that relation between gear position and condition of ATF pressure switch 2 is irregular during releasing accelerator pedal. (Other than during shift change)

### Possible Cause

UCS0046Z

- Harness or connectors  
(The solenoid and switch circuits are open or shorted.)
- Low coast brake solenoid valve
- ATF pressure switch 2

### DTC Confirmation Procedure

UCS00470

#### CAUTION:

Always drive vehicle at a safe speed.

#### NOTE:

If “DTC Confirmation Procedure” has been previously performed, always turn ignition switch “OFF” and wait at least 10 seconds before performing the next test.

After the repair, perform the following procedure to confirm the malfunction is eliminated.

#### WITH CONSULT-II

1. Start engine.
2. Accelerate vehicle to maintain the following conditions.  
**Selector lever: “1” or “2” position**  
**Gear position: “1st” or “2nd” gear (LC/B ON/OFF)**
3. Perform step “2” again.
4. Turn ignition switch “OFF”, then perform step “1” to “3” again.
5. Check “SELF-DIAG RESULTS” mode for “A/T” with CONSULT-II. If DTC (P1774) is detected, refer to [AT-159, "Diagnostic Procedure"](#) .  
If DTC (P1772) is detected, go to [AT-157, "Diagnostic Procedure"](#) .

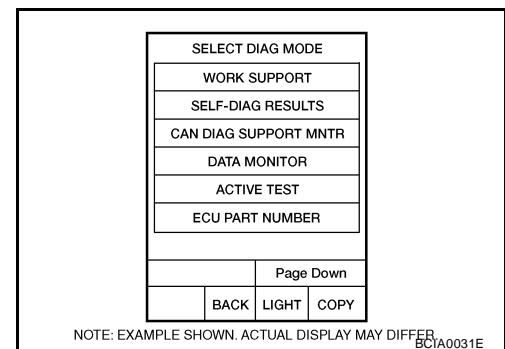

#### WITH GST

Follow the procedure “WITH CONSULT-II”.

# DTC P1774 LOW COAST BRAKE SOLENOID VALVE FUNCTION

UCS00471

## Diagnostic Procedure

### 1. CHECK INPUT SIGNALS

#### With CONSULT-II

1. Start the engine.
2. Select "SELECTION FROM MENU" in "DATA MONITOR" mode for "A/T" with CONSULT-II.
3. Drive vehicle in the "1" or "2" position (11 or 22 gear), and confirm the ON/OFF actuation of the "ATF PRES SW 2" and "ON OFF SOL".

#### OK or NG

- OK >> GO TO 4.  
NG >> GO TO 2.

DATA MONITOR			
MONITOR		NO DTC	
ON OFF SOL		OFF	
ATF PRES SW 2		OFF	
		RECORD	
MODE	BACK	LIGHT	COPY

SCIA4794E

### 2. CHECK TCM POWER SUPPLY AND GROUND CIRCUIT

Check TCM power supply and ground circuit. Refer to [AT-168, "MAIN POWER SUPPLY AND GROUND CIRCUIT"](#).

#### OK or NG

- OK >> GO TO 3.  
NG >> Repair or replace damaged parts.

### 3. DETECT MALFUNCTIONING ITEM

Check the following.

- The A/T assembly harness connector pin terminals for damage or loose connection with harness connector.

#### OK or NG

- OK >> Replace the control valve with TCM. Refer to [AT-228, "Control Valve With TCM and A/T Fluid Temperature Sensor 2"](#).
- NG >> Repair or replace damaged parts.

### 4. CHECK DTC

Perform "DTC Confirmation Procedure".

- Refer to [AT-158, "DTC Confirmation Procedure"](#).

#### OK or NG

- OK >> **INSPECTION END**  
NG >> GO TO 2.

# DTC P1841 ATF PRESSURE SWITCH 1

## DTC P1841 ATF PRESSURE SWITCH 1

PF2:25240

### Description

UCS00472

Fail-safe function to detect front brake clutch solenoid valve condition.

### CONSULT-II Reference Value

UCS00473

Item name	Condition	Display value
ATF PRES SW 1	Front brake engaged. Refer to <a href="#">AT-21</a> .	ON
	Front brake disengaged. Refer to <a href="#">AT-21</a> .	OFF

### On Board Diagnosis Logic

UCS00474

- This is not an OBD-II self-diagnostic item.
- Diagnostic trouble code "P1841 ATF PRES SW 1/CIRC" with CONSULT-II is detected when TCM detects that actual gear ratio is normal, and relation between gear position and condition of ATF pressure switch 1 is irregular during depressing accelerator pedal. (Other than during shift change)

### Possible Cause

UCS00475

- ATF pressure switch 1
- Harness or connectors  
(The switch circuit is open or shorted.)

### DTC Confirmation Procedure

UCS00476

#### CAUTION:

Always drive vehicle at a safe speed.

#### NOTE:

If "DTC Confirmation Procedure" has been previously performed, always turn ignition switch "OFF" and wait at least 10 seconds before performing the next test.

After the repair, perform the following procedure to confirm the malfunction is eliminated.

#### WITH CONSULT-II

1. Start engine.
2. Accelerate vehicle to maintain the following conditions.  
**ACCELE POS: 1.5/8 - 2.0/8**  
**Selector lever: "D" position**  
**Gear position: 3rd ⇒ 4th Gear (FR/B ON/OFF)**  
**Driving location: Driving the vehicle uphill (increased engine load) will help maintain the driving conditions required for this test.**
3. Perform step "2" again.
4. Turn ignition switch "OFF", then perform step "1" to "3" again.
5. Check "SELF-DIAG RESULTS" mode for "A/T" with CONSULT-II.  
If DTC (P1841) is detected, go to [AT-161, "Diagnostic Procedure"](#) .  
If DTC (P1757) is detected, go to [AT-145, "Diagnostic Procedure"](#) .

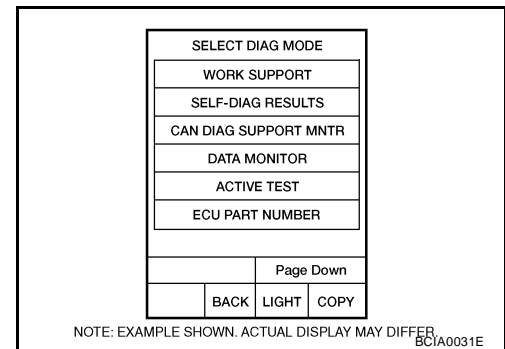



# DTC P1841 ATF PRESSURE SWITCH 1

UCS00477

## Diagnostic Procedure

### 1. CHECK INPUT SIGNAL

#### With CONSULT-II

1. Start engine.
2. Select "ECU INPUT SIGNALS" or "MAIN SIGNALS" in "DATA MONITOR" mode for "A/T" with CONSULT-II.
3. Drive vehicle in the "D" position (3rd ⇒ 4th gear), and confirm the ON/OFF actuation of the "ATF PRES SW 1".

DATA MONITOR			
MONITOR		NO DTC	
ATF PRES SW 1		OFF	
ATF PRES SW 2		OFF	
ATF PRES SW 3		OFF	
ATF PRES SW 5		OFF	
ATF PRES SW 6		OFF	

△		▽	
RECORD			
MODE	BACK	LIGHT	COPY

PCIA0067E

#### OK or NG

- OK >> GO TO 4.  
NG >> GO TO 2.

### 2. CHECK TCM POWER SUPPLY AND GROUND CIRCUIT

Check TCM power supply and ground circuit. Refer to [AT-168, "MAIN POWER SUPPLY AND GROUND CIRCUIT"](#).

#### OK or NG

- OK >> GO TO 3.  
NG >> Repair or replace damaged parts.

### 3. DETECT MALFUNCTIONING ITEM

Check the following.

- The A/T assembly harness connector pin terminals for damage or loose connection with harness connector.

#### OK or NG

- OK >> Replace the control valve with TCM. Refer to [AT-228, "Control Valve With TCM and A/T Fluid Temperature Sensor 2"](#).
- NG >> Repair or replace damaged parts.

### 4. CHECK DTC

Perform "DTC Confirmation Procedure".

- Refer to [AT-161, "Diagnostic Procedure"](#).

#### OK or NG

- OK >> **INSPECTION END**  
NG >> GO TO 2.

# DTC P1843 ATF PRESSURE SWITCH 3

## DTC P1843 ATF PRESSURE SWITCH 3

PFP:25240

### Description

UCS00478

Fail-safe function to detect input clutch solenoid valve condition.

### CONSULT-II Reference Value

UCS00479

Item name	Condition	Display value
ATF PRES SW 3	Input clutch engaged. Refer to <a href="#">AT-21</a> .	ON
	Input clutch disengaged. Refer to <a href="#">AT-21</a> .	OFF

### On Board Diagnosis Logic

UCS0047A

- This is not an OBD-II self-diagnostic item.
- Diagnostic trouble code "P1843 ATF PRES SW 3/CIRC" with CONSULT-II is detected when TCM detects that actual gear ratio is normal, and relation between gear position and condition of ATF pressure switch 3 is irregular during depressing accelerator pedal. (Other than during shift change)

### Possible Cause

UCS0047B

- ATF pressure switch 3
- Harness or connectors  
(The switch circuit is open or shorted.)

### DTC Confirmation Procedure

UCS0047C

#### CAUTION:

Always drive vehicle at a safe speed.

#### NOTE:

If "DTC Confirmation Procedure" has been previously performed, always turn ignition switch "OFF" and wait at least 10 seconds before performing the next test.

After the repair, perform the following procedure to confirm the malfunction is eliminated.

#### WITH CONSULT-II

1. Start engine.
2. Accelerate vehicle to maintain the following conditions.  
**ACCELE POS: 1.5/8 - 2.0/8**  
**Selector lever: "D" position**  
**Gear position: 3rd ⇒ 4th Gear (I/C ON/OFF)**  
**Driving location: Driving the vehicle uphill (increased engine load) will help maintain the driving conditions required for this test.**
3. Perform step "2" again.
4. Turn ignition switch "OFF", then perform step "1" to "3" again.
5. Check "SELF-DIAG RESULTS" mode for "A/T" with CONSULT-II.  
If DTC (P1843) is detected, go to [AT-163, "Diagnostic Procedure"](#) .  
If DTC (P1752) is detected, go to [AT-141, "Diagnostic Procedure"](#) .

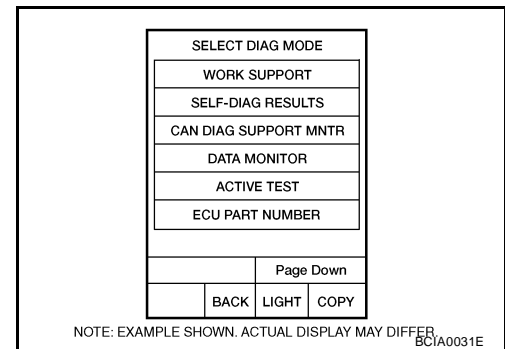

# DTC P1843 ATF PRESSURE SWITCH 3

UCS0047D

## Diagnostic Procedure

### 1. CHECK INPUT SIGNAL

#### With CONSULT-II

1. Start engine.
2. Select "ECU INPUT SIGNALS" or "MAIN SIGNALS" in "DATA MONITOR" mode for "A/T" with CONSULT-II.
3. Drive vehicle in the "D" position (3rd ⇒ 4th gear), and confirm the ON/OFF actuation of the "ATF PRES SW 3".

DATA MONITOR			
MONITOR		NO DTC	
ATF PRES SW 1		OFF	
ATF PRES SW 2		OFF	
ATF PRES SW 3		OFF	
ATF PRES SW 5		OFF	
ATF PRES SW 6		OFF	

△		▽	
RECORD			
MODE	BACK	LIGHT	COPY

PCIA0067E

#### OK or NG

- OK >> GO TO 4.  
NG >> GO TO 2.

### 2. CHECK TCM POWER SUPPLY AND GROUND CIRCUIT

Check TCM power supply and ground circuit. Refer to [AT-168, "MAIN POWER SUPPLY AND GROUND CIRCUIT"](#).

#### OK or NG

- OK >> GO TO 3.  
NG >> Repair or replace damaged parts.

### 3. DETECT MALFUNCTIONING ITEM

Check the following.

- The A/T assembly harness connector pin terminals for damage or loose connection with harness connector.

#### OK or NG

- OK >> Replace the control valve with TCM. Refer to [AT-228, "Control Valve With TCM and A/T Fluid Temperature Sensor 2"](#).  
NG >> Repair or replace damaged parts.

### 4. CHECK DTC

Perform "DTC Confirmation Procedure".

- Refer to [AT-163, "Diagnostic Procedure"](#).

#### OK or NG

- OK >> **INSPECTION END**  
NG >> GO TO 2.

# DTC P1845 ATF PRESSURE SWITCH 5

## DTC P1845 ATF PRESSURE SWITCH 5

PFP:25240

### Description

UCS0047E

Fail-safe function to detect direct clutch solenoid valve condition.

### CONSULT-II Reference Value

UCS0047F

Item name	Condition	Display value
ATF PRES SW 5	Direct clutch engaged. Refer to <a href="#">AT-21</a> .	ON
	Direct clutch disengaged. Refer to <a href="#">AT-21</a> .	OFF

### On Board Diagnosis Logic

UCS0047G

- This is not an OBD-II self-diagnostic item.
- Diagnostic trouble code "P1845 ATF PRES SW 5/CIRC" with CONSULT-II is detected when TCM detects that actual gear ratio is normal, and relation between gear position and condition of ATF pressure switch 5 is irregular during depressing accelerator pedal. (Other than during shift change)

### Possible Cause

UCS0047H

- ATF pressure switch 5
- Harness or connectors  
(The switch circuit is open or shorted.)

### DTC Confirmation Procedure

UCS0047I

#### CAUTION:

Always drive vehicle at a safe speed.

#### NOTE:

If "DTC Confirmation Procedure" has been previously performed, always turn ignition switch "OFF" and wait at least 10 seconds before performing the next test.

After the repair, perform the following procedure to confirm the malfunction is eliminated.

#### WITH CONSULT-II

1. Start engine.
2. Accelerate vehicle to maintain the following conditions.  
**ACCELE POS: 1.5/8 - 2.0/8**  
**Selector lever: "D" position**  
**Gear position: 1st ⇒ 2nd Gear (D/C ON/OFF)**  
**Driving location: Driving the vehicle uphill (increased engine load) will help maintain the driving conditions required for this test.**
3. Perform step "2" again.
4. Turn ignition switch "OFF", then perform step "1" to "3" again.
5. Check "SELF-DIAG RESULTS" mode for "A/T" with CONSULT-II.  
If DTC (P1845) is detected, go to [AT-165, "Diagnostic Procedure"](#) .  
If DTC (P1762) is detected, go to [AT-149, "Diagnostic Procedure"](#) .

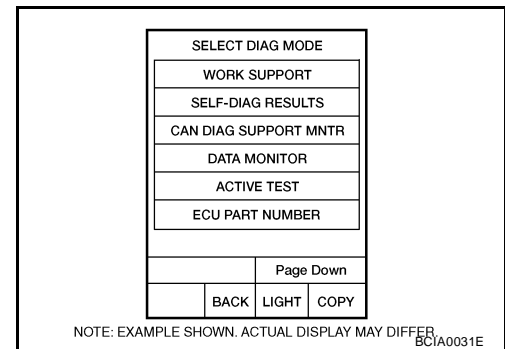

# DTC P1845 ATF PRESSURE SWITCH 5

UCS0047J

## Diagnostic Procedure

### 1. CHECK INPUT SIGNAL

#### With CONSULT-II

1. Start engine.
2. Select "ECU INPUT SIGNALS" or "MAIN SIGNALS" in "DATA MONITOR" mode for "A/T" with CONSULT-II.
3. Drive vehicle in the "D" position (1st ⇒ 2nd gear), and confirm the ON/OFF actuation of the "ATF PRES SW 5".

#### OK or NG

- OK >> GO TO 4.  
NG >> GO TO 2.

DATA MONITOR			
MONITOR		NO DTC	
ATF PRES SW 1		OFF	
ATF PRES SW 2		OFF	
ATF PRES SW 3		OFF	
ATF PRES SW 5		OFF	
ATF PRES SW 6		OFF	

△		▽	
RECORD			
MODE	BACK	LIGHT	COPY

PCIA0067E

### 2. CHECK TCM POWER SUPPLY AND GROUND CIRCUIT

Check TCM power supply and ground circuit. Refer to [AT-168, "MAIN POWER SUPPLY AND GROUND CIRCUIT"](#).

#### OK or NG

- OK >> GO TO 3.  
NG >> Repair or replace damaged parts.

### 3. DETECT MALFUNCTIONING ITEM

Check the following.

- The A/T assembly harness connector pin terminals for damage or loose connection with harness connector.

#### OK or NG

- OK >> Replace the control valve with TCM. Refer to [AT-228, "Control Valve With TCM and A/T Fluid Temperature Sensor 2"](#).
- NG >> Repair or replace damaged parts.

### 4. CHECK DTC

Perform "DTC Confirmation Procedure".

- Refer to [AT-164, "DTC Confirmation Procedure"](#).

#### OK or NG

- OK >> **INSPECTION END**  
NG >> GO TO 2.

# DTC P1846 ATF PRESSURE SWITCH 6

## DTC P1846 ATF PRESSURE SWITCH 6

PFP:25240

### Description

UCS0047K

Fail-safe function to detect high and low reverse clutch solenoid valve condition.

### CONSULT-II Reference Value

UCS0047L

Item name	Condition	Display value
ATF PRES SW 6	High and low reverse clutch engaged. Refer to <a href="#">AT-21</a> .	ON
	High and low reverse clutch disengaged. Refer to <a href="#">AT-21</a> .	OFF

### On Board Diagnosis Logic

UCS0047M

- This is not an OBD-II self-diagnostic item.
- Diagnostic trouble code "P1846 ATF PRES SW 6/CIRC" with CONSULT-II is detected when TCM detects that actual gear ratio is normal, and relation between gear position and condition of ATF pressure switch 6 is irregular during depressing accelerator pedal. (Other than during shift change)

### Possible Cause

UCS0047N

- ATF pressure switch 6
- Harness or connectors  
(The switch circuit is open or shorted.)

### DTC Confirmation Procedure

UCS0047O

#### CAUTION:

Always drive vehicle at a safe speed.

#### NOTE:

If "DTC Confirmation Procedure" has been previously performed, always turn ignition switch "OFF" and wait at least 10 seconds before performing the next test.

After the repair, perform the following procedure to confirm the malfunction is eliminated.

#### ④ WITH CONSULT-II

1. Start engine.
2. Accelerate vehicle to maintain the following conditions.  
**ACCELE POS: 1.5/8 - 2.0/8**  
**Selector lever: "D" position**  
**Gear position: 2nd ⇒ 3rd Gear (HLR/C ON/OFF)**  
**Driving location: Driving the vehicle uphill (increased engine load) will help maintain the driving conditions required for this test.**
3. Perform step "2" again.
4. Turn ignition switch "OFF", then perform step "1" to "3" again.
5. Check "SELF-DIAG RESULTS" mode for "A/T" with CONSULT-II.  
If DTC (P1846) is detected, go to [AT-167, "Diagnostic Procedure"](#) .  
If DTC (P1767) is detected, go to [AT-153, "Diagnostic Procedure"](#) .

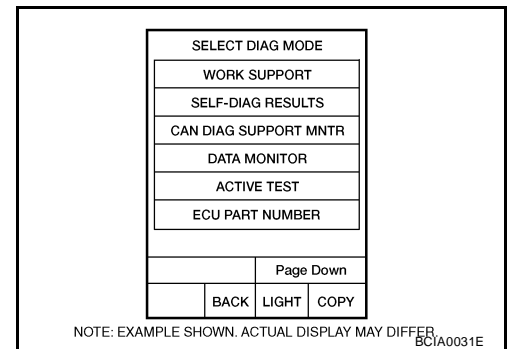

# DTC P1846 ATF PRESSURE SWITCH 6

UCS0047P

## Diagnostic Procedure

### 1. CHECK INPUT SIGNAL

#### With CONSULT-II

1. Start the engine.
2. Select "ECU INPUT SIGNALS" or "MAIN SIGNALS" in "DATA MONITOR" mode for "A/T" with CONSULT-II.
3. Drive vehicle in the "D" position (2nd ⇒ 3rd gear), and confirm the ON/OFF actuation of the "ATF PRES SW 6".

DATA MONITOR			
MONITOR		NO DTC	
ATF PRES SW 1		OFF	
ATF PRES SW 2		OFF	
ATF PRES SW 3		OFF	
ATF PRES SW 5		OFF	
ATF PRES SW 6		OFF	

△	▽		
RECORD			
MODE	BACK	LIGHT	COPY

PCIA0067E

#### OK or NG

- OK >> GO TO 4.  
NG >> GO TO 2.

### 2. CHECK TCM POWER SUPPLY AND GROUND CIRCUIT

Check TCM power supply and ground circuit. Refer to [AT-168, "MAIN POWER SUPPLY AND GROUND CIRCUIT"](#).

#### OK or NG

- OK >> GO TO 3.  
NG >> Repair or replace damaged parts.

### 3. DETECT MALFUNCTIONING ITEM

Check the following.

- The A/T assembly harness connector pin terminals for damage or loose connection with harness connector.

#### OK or NG

- OK >> Replace the control valve with TCM. Refer to [AT-228, "Control Valve With TCM and A/T Fluid Temperature Sensor 2"](#).  
NG >> Repair or replace damaged parts.

### 4. CHECK DTC

Perform "DTC Confirmation Procedure".

- Refer to [AT-166, "DTC Confirmation Procedure"](#).

#### OK or NG

- OK >> **INSPECTION END**  
NG >> GO TO 2.

# MAIN POWER SUPPLY AND GROUND CIRCUIT

## MAIN POWER SUPPLY AND GROUND CIRCUIT

PF:00100

### Wiring Diagram — AT — MAIN

UCS0047Q

### AT-MAIN-01

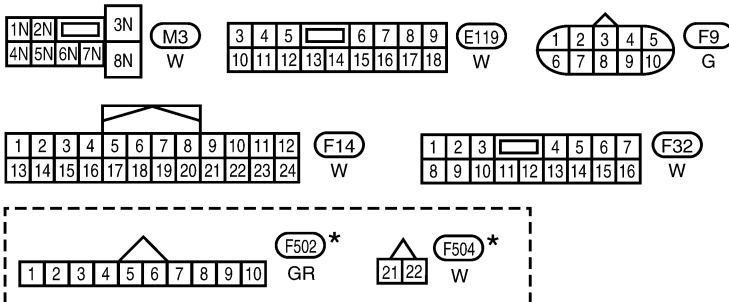
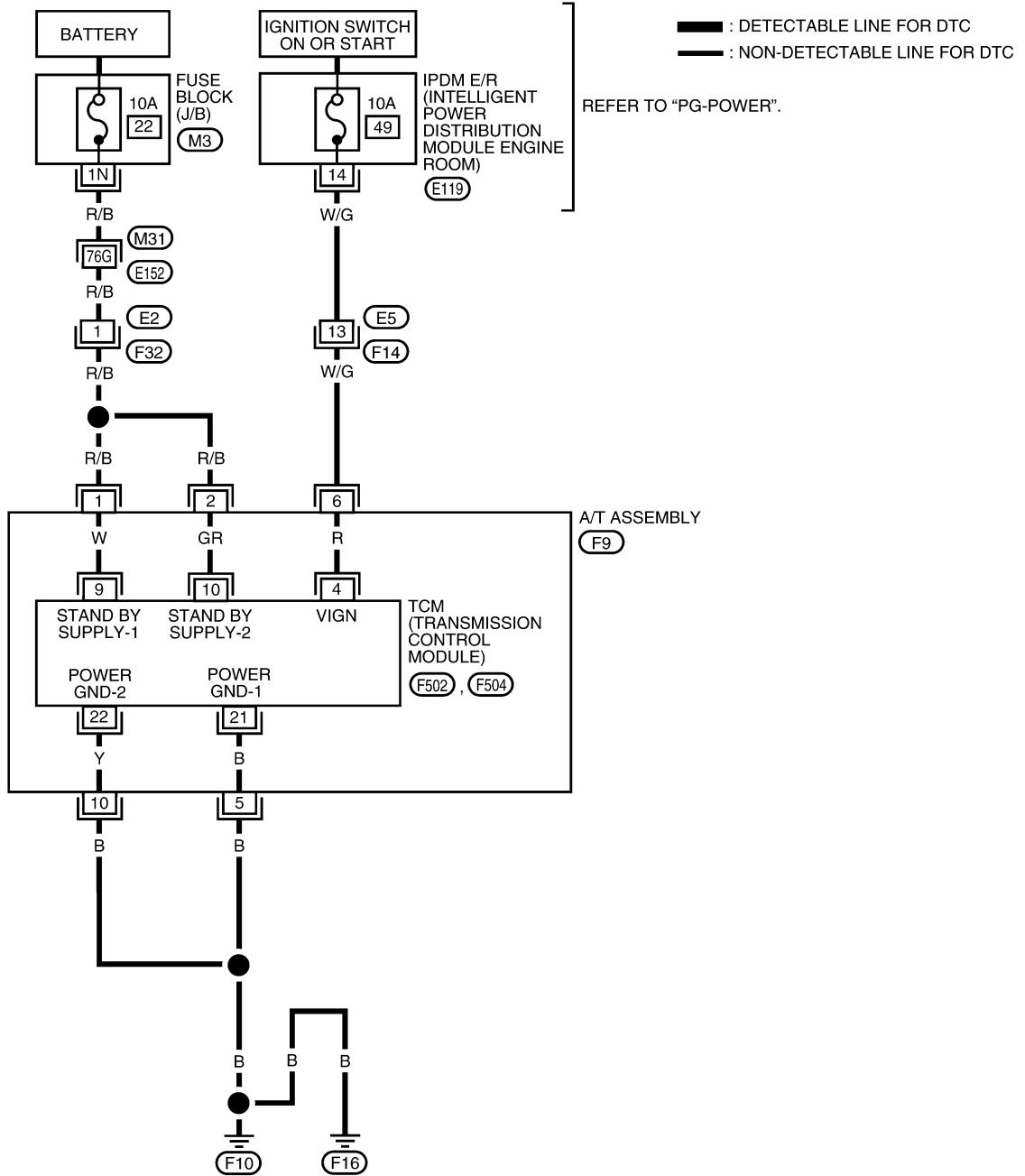

\*: THIS CONNECTOR IS NOT SHOWN IN "HARNESS LAYOUT" OF PG SECTION.

REFER TO THE FOLLOWING.

(M31) - SUPER MULTIPLE JUNCTION (SMJ)

BCWA0579E



# MAIN POWER SUPPLY AND GROUND CIRCUIT

## TCM INPUT/OUTPUT SIGNAL REFERENCE VALUES

Refer to [AT-86, "TCM Input/Output Signal Reference Values"](#) .

### Diagnostic Procedure

UCS0047R

#### 1. CHECK TCM POWER SOURCE STEP 1

1. Turn ignition switch OFF.
2. Disconnect A/T assembly harness connector.
3. Check voltage between A/T assembly harness connector terminals and ground.

Item	Connector	Terminal	Voltage
TCM	F9	1 - Ground	Battery voltage
		2 - Ground	
		6 - Ground	0V

#### OK or NG

- OK >> GO TO 2.  
 NG >> GO TO 3.

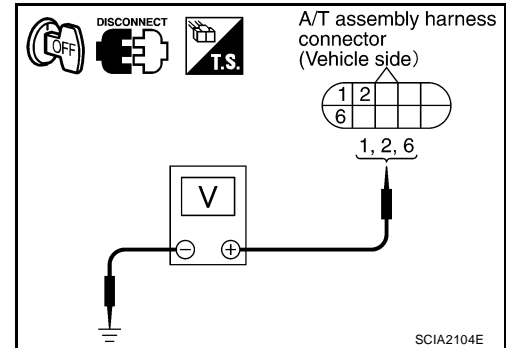

#### 2. CHECK TCM POWER SOURCE STEP 2

1. Disconnect A/T assembly harness connector.
2. Turn ignition switch ON. (Do not start engine.)
3. Check voltage between A/T assembly harness connector terminals and ground.

Item	Connector	Terminal	Voltage
TCM	F9	1 - Ground	Battery voltage
		2 - Ground	
		6 - Ground	

#### OK or NG

- OK >> GO TO 4.  
 NG >> GO TO 3.

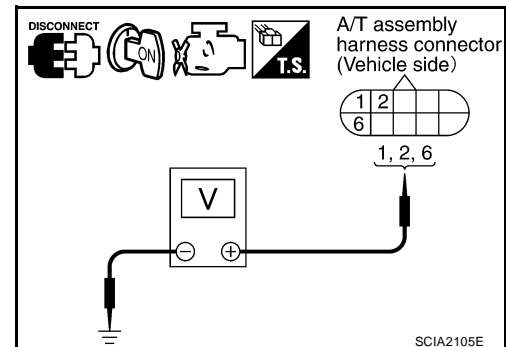

#### 3. DETECT MALFUNCTIONING ITEM

Check the following.

- Harness for short or open between battery and A/T assembly harness connector terminals 1, 2
- Harness for short or open between ignition switch and A/T assembly harness connector terminal 6
- 10A fuse [No. 22, located in the fuse block (J/B)] and 10A fuse (No. 49, located in the IPDM E/R)
- Ignition switch, Refer to [PG-4, "POWER SUPPLY ROUTING CIRCUIT"](#) .

#### OK or NG

- OK >> GO TO 4.  
 NG >> Repair or replace damaged parts.

# MAIN POWER SUPPLY AND GROUND CIRCUIT

## 4. CHECK TCM GROUND CIRCUIT

1. Turn ignition switch OFF.
2. Disconnect A/T assembly harness connector.
3. Check continuity between A/T assembly harness connector terminals and ground.

Item	Connector	Terminal	Continuity
TCM	F9	5, 10 - Ground	Yes

If OK, check harness for short to ground and short to power.

### OK or NG

- OK >> GO TO 5.  
NG >> Repair open circuit or short to ground or short to power in harness or connectors.

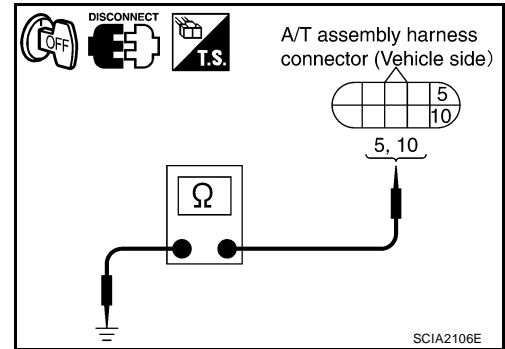

## 5. DETECT MALFUNCTIONING ITEM

Check the following.

- The A/T assembly harness connector terminals for damage or loose connection with harness connector.

### OK or NG

- OK >> GO TO 6.  
NG >> Repair or replace damaged parts.

## 6. PERFORM SELF-DIAGNOSIS

Perform self-diagnosis. Refer to [AT-89, "SELF-DIAGNOSTIC RESULT MODE"](#) .

### OK or NG

- OK >> **INSPECTION END**  
NG-1 >> Self-diagnosis does not activate: GO TO 7.  
NG-2 >> DTC is displayed: Check the malfunctioning system. Refer to [AT-89, "SELF-DIAGNOSTIC RESULT MODE"](#) .

# MAIN POWER SUPPLY AND GROUND CIRCUIT

## 7. CHECK TERMINAL CORD ASSEMBLY

1. Remove control valve with TCM. Refer to [AT-228, "Control Valve With TCM and A/T Fluid Temperature Sensor 2"](#) .
2. Disconnect A/T assembly harness connector and TCM connector.
3. Check continuity between A/T assembly harness connector terminals and TCM connector terminals.

Item	Connector	Terminal	Voltage
A/T assembly harness connector	F9	1	Yes
TCM connector	F502	9	
A/T assembly harness connector	F9	2	Yes
TCM connector	F502	10	
A/T assembly harness connector	F9	6	Yes
TCM connector	F502	4	

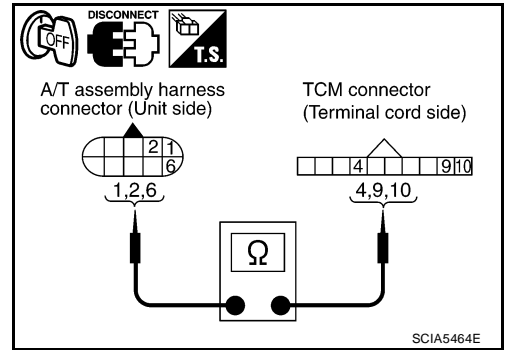

4. Check continuity between A/T assembly harness connector terminals and TCM connector terminals.

Item	Connector	Terminal	Voltage
A/T assembly harness connector	F9	5	Yes
TCM connector	F504	21	
A/T assembly harness connector	F9	10	Yes
TCM connector	F504	22	

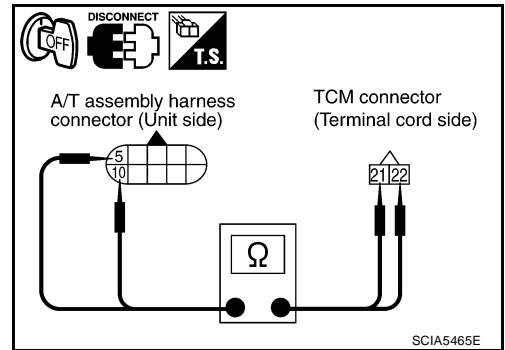

5. If OK, check harness for short to ground and short to power.  
OK or NG

- OK >> Replace the control valve with TCM. Refer to [AT-228, "Control Valve With TCM and A/T Fluid Temperature Sensor 2"](#) .
- NG >> Replace open circuit or short to ground and short to power in harness or connectors.

# CLOSED THROTTLE POSITION AND WIDE OPEN THROTTLE POSITION CIRCUIT

## CLOSED THROTTLE POSITION AND WIDE OPEN THROTTLE POSITION CIRCUIT

PF18002

### CONSULT-II Reference Value

UCS0047S

Item name	Condition	Display value
CLSD THL POS	Released accelerator pedal.	ON
	Fully depressed accelerator pedal.	OFF
W/O THL POS	Fully depressed accelerator pedal.	ON
	Released accelerator pedal.	OFF

### Diagnostic Procedure

UCS0047T

#### 1. CHECK CAN COMMUNICATION LINE

Perform the self-diagnosis. Refer to [AT-89, "SELF-DIAGNOSTIC RESULT MODE"](#) .

Is a malfunction in the CAN communication indicated in the results?

- YES >> Check CAN communication line. Refer to [AT-98, "DTC U1000 CAN COMMUNICATION LINE"](#) .  
 NO >> GO TO 2.

#### 2. CHECK THROTTLE POSITION SIGNAL CIRCUIT

##### With CONSULT-II

- Turn ignition switch "ON". (Do not start engine.)
- Select "ECU INPUT SIGNALS" in "DATA MONITOR" mode for "A/T" with CONSULT-II.
- Depress accelerator pedal and read out the value of "CLSD THL POS" and "W/O THL POS".

##### OK or NG

OK >> **INSPECTION END**

NG >> Check the following. If NG, repair or replace damaged parts.

- Perform the self-diagnosis for "ENGINE" with CONSULT-II.
- Open circuit or short to ground or short to power in harness or connectors.
- Pin terminals for damage or loose connection with harness connector.

DATA MONITOR	
MONITOR	NO DTC
ACCELE POSI	0.0/8
THROTTLE POSI	0.0/8
CLSD THL POS	ON
W/O THL POS	OFF
BRAKE SW	OFF
▽	
RECORD	
MODE	BACK
LIGHT	COPY

PCIA0070E

# BRAKE SIGNAL CIRCUIT

## BRAKE SIGNAL CIRCUIT

PF2:25320

### CONSULT-II Reference Value

UCS0047U

Item name	Condition	Display value
BRAKE SW	Depressed brake pedal.	ON
	Released brake pedal.	OFF

### Diagnostic Procedure

UCS0047V

#### 1. CHECK CAN COMMUNICATION LINE

Perform the self-diagnosis. Refer to [AT-89, "SELF-DIAGNOSTIC RESULT MODE"](#).

Is a malfunction in the CAN communication indicated in the results?

- YES >> Check CAN communication line. Refer to [AT-98, "DTC U1000 CAN COMMUNICATION LINE"](#).  
 NO >> GO TO 2.

#### 2. CHECK STOP LAMP SWITCH CIRCUIT

##### Ⓜ With CONSULT-II

- Turn ignition switch "ON". (Do not start engine.)
- Select "ECU INPUT SIGNALS" in "DATA MONITOR" mode for "A/T" with CONSULT-II.
- Read out ON/OFF switching action of the "BRAKE SW".

OK or NG

- OK >> **INSPECTION END**  
 NG >> GO TO 3.

DATA MONITOR	
MONITOR	NO DTC
ACCELE POSI	0.0/8
THROTTLE POSI	0.0/8
CLSD THL POS	ON
W/O THL POS	OFF
BRAKE SW	OFF

▽			
RECORD			
MODE	BACK	LIGHT	COPY

PCIA0070E

#### 3. CHECK STOP LAMP SWITCH

Check continuity between stop lamp switch harness connector terminals 1 and 2.

Item	Condition	Terminal	Continuity
Stop lamp switch harness connector	When brake pedal is depressed	1 - 2	Yes
	When brake pedal is released		No

Check stop lamp switch after adjusting brake pedal — refer to [BR-6, "BRAKE PEDAL"](#).

OK or NG

- OK >> Check the following. If NG, repair or replace damaged parts.
- Harness for short or open between battery and stop lamp switch.
  - Harness for short or open between stop lamp switch and combination meter.
- NG >> Repair or replace the stop lamp switch.

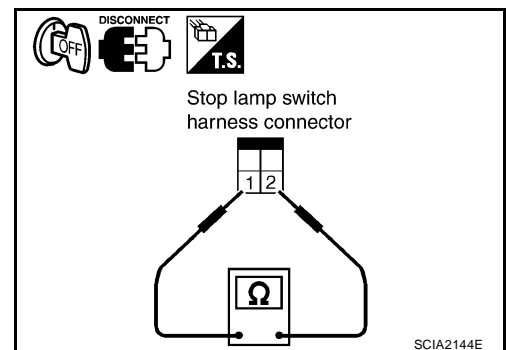

# OVERDRIVE CONTROL SWITCH

## OVERDRIVE CONTROL SWITCH

PF2:25130

### CONSULT-II Reference Value

UCS0047W

Item name	Condition	Display value
OD CONT SW	Releasing overdrive control switch	OFF
	Holding overdrive control switch	ON

### Diagnostic Procedure

UCS0047X

#### 1. CHECK CAN COMMUNICATION LINE

Perform the self-diagnosis. Refer to [AT-89, "SELF-DIAGNOSTIC RESULT MODE"](#) .

Is any malfunction in the CAN communication indicated in the results?

- YES >> Check CAN communication line. Refer to [AT-98, "DTC U1000 CAN COMMUNICATION LINE"](#) .  
 NO >> GO TO 2.

#### 2. CHECK OVERDRIVE CONTROL SWITCH CIRCUIT

##### Ⓜ With CONSULT-II

- Turn ignition switch "ON".
- Select "ECU INPUT SIGNALS" in "DATA MONITOR" mode for "A/T" with CONSULT-II.
- Read out "OD CONT SW".  
Check the signal of the overdrive control switch is indicated properly.

Monitor item	Condition	Display value
OD CONT SW	Releasing overdrive control switch	OFF
	Holding overdrive control switch	ON

DATA MONITOR	
MONITORING	
1 POSITION SW	OFF
OD CONT SW	ON
POWERSHIFT SW	OFF
HOLD SW	OFF
MANU MODE SW	OFF

LCIA0339E

##### ⓧ Without CONSULT-II

- Turn ignition switch "ON". (Do not start engine)
- Check voltage between A/T control device connector terminal and ground.

Item	Connector No.	Terminal No.	Condition	Data (Approx.)
Overdrive control switch	M156	7 - Ground	Releasing overdrive control switch	Battery voltage
			Holding overdrive control switch	0V

##### OK or NG

- OK >> GO TO 5.  
 NG >> GO TO 3.

# OVERDRIVE CONTROL SWITCH

---

## 3. CHECK OVERDRIVE CONTROL SWITCH

---

1. Turn ignition switch "OFF".
2. Disconnect A/T control device connector.
3. Check continuity between A/T control device connector M156 terminals 7 and 8.

Condition	Continuity
Releasing overdrive control switch	No
Holding overdrive control switch	Yes

### OK or NG

- OK >> GO TO 4.
- NG >> Repair or replace overdrive control switch.

---

## 4. DETECT MALFUNCTIONING ITEM

---

Check the following. If any items are damaged, repair or replace damaged parts.

- Harness for short or open between combination meter connector terminal 20 and A/T control device connector terminal 7.
- Harness for short or open between A/T control device connector terminal 8 and ground.

### OK or NG

- OK >> GO TO 5.
- NG >> Repair or replace damaged parts.

---

## 5. CHECK COMBINATION METER

---

Check the combination meter. Refer to [DI-18, "How to Proceed With Trouble Diagnosis"](#) .

### OK or NG

- OK >> **INSPECTION END**
- NO >> Repair or replace damaged parts.

A  
B  
AT  
D  
E  
F  
G  
H  
I  
J  
K  
L  
M

# TROUBLE DIAGNOSIS FOR SYMPTOMS

## TROUBLE DIAGNOSIS FOR SYMPTOMS

PFP:00007

### Wiring Diagram — AT — NONDTC

UCS0047Y

#### AT-NONDTC-01

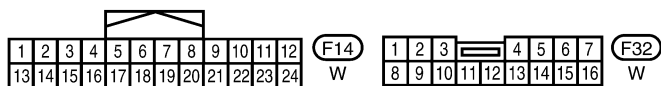
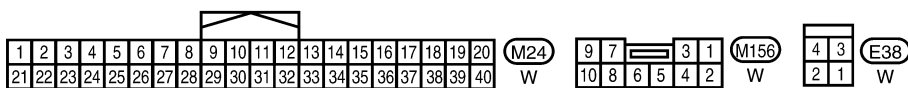
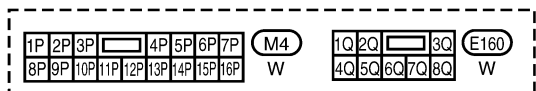
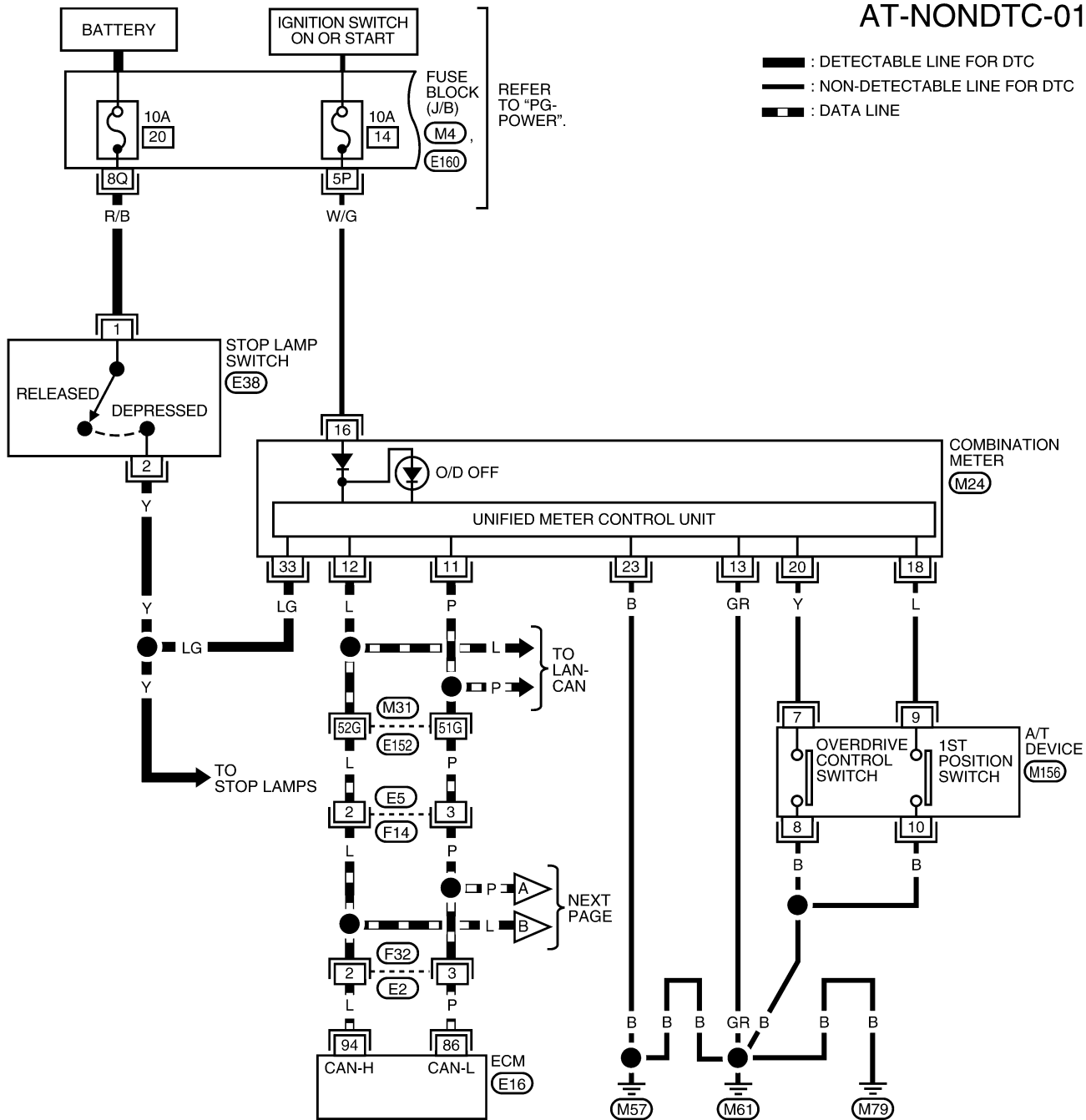



REFER TO THE FOLLOWING.  
 (E16) - ELECTRICAL UNITS  
 (M31) - SUPER MULTIPLE JUNCTION (SMJ)



# TROUBLE DIAGNOSIS FOR SYMPTOMS

## AT-NONDTC-02

-  : DETECTABLE LINE FOR DTC
-  : NON-DETECTABLE LINE FOR DTC
-  : DATA LINE

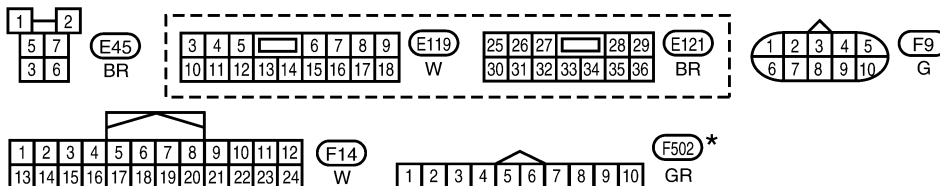
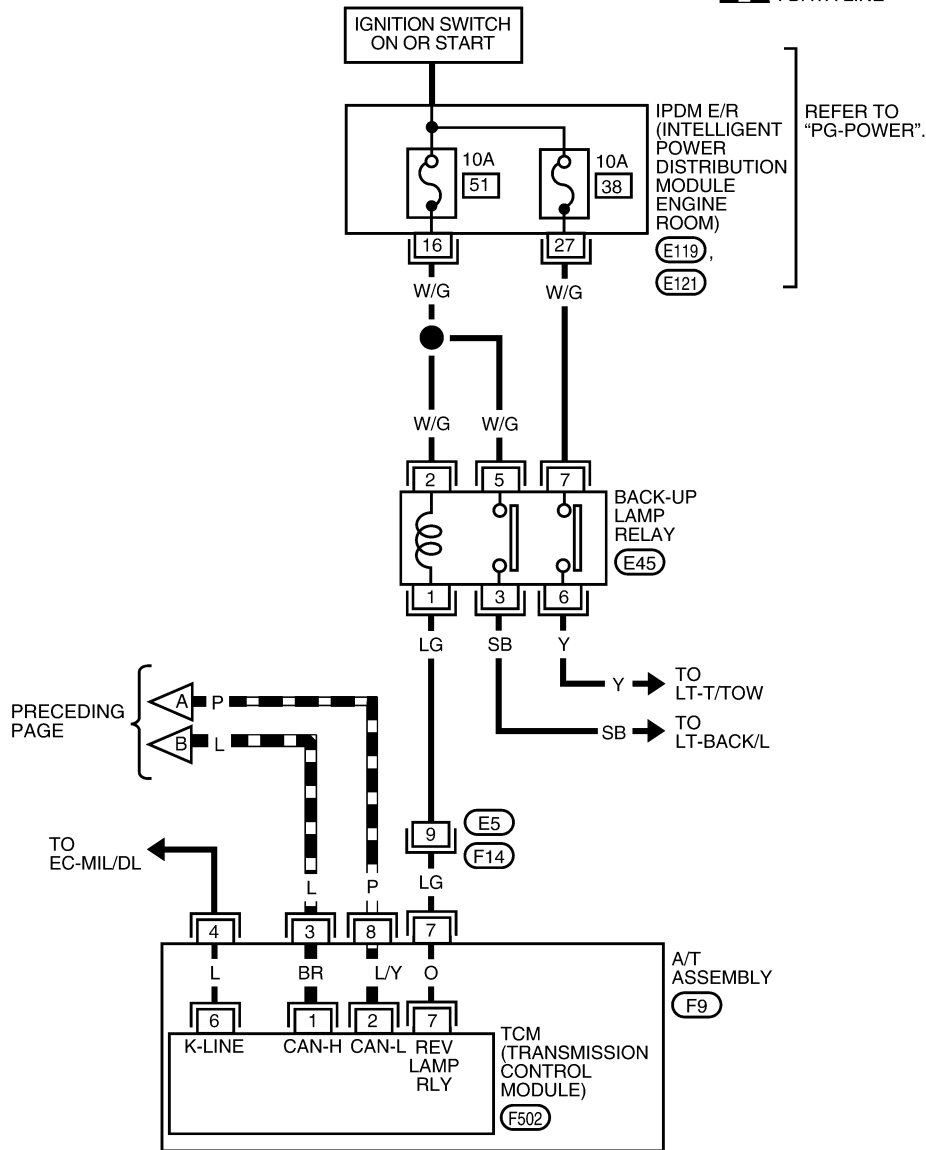

\*: THIS CONNECTOR IS NOT SHOWN IN "HARNESS LAYOUT" OF PG SECTION.

BCWA0580E

# TROUBLE DIAGNOSIS FOR SYMPTOMS

---

## TCM INPUT/OUTPUT SIGNAL REFERENCE VALUES

Refer to [AT-86, "TCM Input/Output Signal Reference Values"](#) .

## O/D OFF Indicator Lamp Does Not Come On SYMPTOM:

UCS0047Z

O/D OFF indicator lamp does not come on for about 2 seconds when turning ignition switch to "ON".

## DIAGNOSTIC PROCEDURE

### 1. CHECK CAN COMMUNICATION LINE

---

Perform self-diagnosis. Refer to [AT-89, "SELF-DIAGNOSTIC RESULT MODE"](#) , [AT-96, "TCM SELF-DIAGNOSTIC PROCEDURE \(NO TOOLS\)"](#) .

Is a malfunction in the CAN communication indicated in the results?

- YES >> Check CAN communication line. Refer to [AT-98, "DTC U1000 CAN COMMUNICATION LINE"](#) .
- NO >> GO TO 2.

### 2. CHECK O/D OFF INDICATOR LAMP CIRCUIT

---

Check the combination meter. Refer to [DI-5, "COMBINATION METERS"](#) .

OK or NG

- OK >> GO TO 3
- NG >> Repair or replace damaged parts.

### 3. CHECK TCM POWER SUPPLY AND GROUND CIRCUIT

---

Check TCM power supply and ground circuit. Refer to [AT-168, "MAIN POWER SUPPLY AND GROUND CIRCUIT"](#) .

OK or NG

- OK >> **INSPECTION END**
- NG >> Repair or replace damaged parts.

# TROUBLE DIAGNOSIS FOR SYMPTOMS

UCS00480

## Engine Cannot Be Started In “P” or “N” Position

### SYMPTOM:

- Engine cannot be started with selector lever in “P” or “N” position.
- Engine can be started with selector lever in “D”, “3”, “2”, “1” or “R” position.

### DIAGNOSTIC PROCEDURE

#### 1. CHECK SELF-DIAGNOSIS RESULTS

Perform self-diagnosis. Refer to [AT-89, "SELF-DIAGNOSTIC RESULT MODE"](#) .

Do the self-diagnosis results indicate PNP switch?

YES >> Check the malfunctioning system. Refer to [AT-106, "DTC P0705 PARK/NEUTRAL POSITION SWITCH"](#) .

NO >> GO TO 2.

#### 2. CHECK CONTROL CABLE

Check the control cable.

- Refer to [AT-217, "Checking of A/T Position"](#) .

OK or NG

OK >> GO TO 3.

NG >> Adjust control cable. Refer to [AT-217, "Adjustment of A/T Position"](#) .

#### 3. CHECK STARTING SYSTEM

Check the starting system. Refer to [SC-10, "STARTING SYSTEM"](#) .

OK or NG

OK >> **INSPECTION END**

NG >> Repair or replace damaged parts.

A

B

AT

D

E

F

G

H

I

J

K

L

M

# TROUBLE DIAGNOSIS FOR SYMPTOMS

UCS00481

## In "P" Position, Vehicle Moves When Pushed

### SYMPTOM:

Even though the selector lever is set in the "P" position, the parking mechanism is not actuated, allowing the vehicle to be moved when it is pushed.

### DIAGNOSTIC PROCEDURE

#### 1. CHECK PNP SWITCH CIRCUIT

Perform self-diagnosis. Refer to [AT-89, "SELF-DIAGNOSTIC RESULT MODE"](#) .

Do the self-diagnosis results indicate PNP switch?

- YES >> Check the malfunctioning system. Refer to [AT-106, "DTC P0705 PARK/NEUTRAL POSITION SWITCH"](#) .
- NO >> GO TO 2.

#### 2. CHECK CONTROL CABLE

Check the control cable.

- Refer to [AT-217, "Checking of A/T Position"](#) .

OK or NG

- OK >> GO TO 3.
- NG >> Adjust control cable. Refer to [AT-217, "Adjustment of A/T Position"](#) .

#### 3. CHECK A/T FLUID CONDITION

1. Remove oil pan. Refer to [AT-228, "Control Valve With TCM and A/T Fluid Temperature Sensor 2"](#) .
2. Check A/T fluid condition. Refer to [AT-52, "Fluid Condition Check"](#) .

OK or NG

- OK >> **INSPECTION END**
- NG >> GO TO 4.

#### 4. DETECT MALFUNCTIONING ITEM

- Check the malfunction items. If any items are damaged, repair or replace damaged parts. Refer to [AT-64, "Symptom Chart"](#) (Symptom No. 58).

OK or NG

- OK >> **INSPECTION END**
- NG >> Repair or replace damaged parts.

# TROUBLE DIAGNOSIS FOR SYMPTOMS

UCS00482

## In "N" Position, Vehicle Moves

### SYMPTOM:

Vehicle moves forward or backward when selecting "N" position.

### DIAGNOSTIC PROCEDURE

#### 1. CHECK PNP SWITCH CIRCUIT

Perform self-diagnosis. Refer to [AT-89, "SELF-DIAGNOSTIC RESULT MODE"](#) .

Do the self-diagnostic results indicate PNP switch?

YES >> Check the malfunctioning system. Refer to [AT-106, "DTC P0705 PARK/NEUTRAL POSITION SWITCH"](#) .

NO >> GO TO 2.

#### 2. CHECK CONTROL CABLE

Check the control cable.

- Refer to [AT-217, "Checking of A/T Position"](#) .

OK or NG

OK >> GO TO 3.

NG >> Adjust control cable. Refer to [AT-217, "Adjustment of A/T Position"](#) .

#### 3. CHECK A/T FLUID LEVEL

Check A/T fluid level. Refer to [AT-12, "Checking the A/T Fluid \(ATF\)"](#) .

OK or NG

OK >> GO TO 4.

NG >> Refill ATF.

#### 4. CHECK A/T FLUID CONDITION

1. Remove oil pan. Refer to [AT-228, "Control Valve With TCM and A/T Fluid Temperature Sensor 2"](#) .

2. Check A/T fluid condition. Refer to [AT-52, "Fluid Condition Check"](#) .

OK or NG

OK >> GO TO 5.

NG >> Check the malfunction items. If any items are damaged, repair or replace damaged parts. Refer to [AT-64, "Symptom Chart"](#) (Symptom No. 60).

#### 5. CHECK SYMPTOM

Check again. Refer to [AT-56, "Check at Idle"](#) .

OK or NG

OK >> **INSPECTION END**

NG >> GO TO 6.

#### 6. PERFORM TCM INSPECTION

1. Perform TCM input/output signals inspection. Refer to [AT-86, "TCM Input/Output Signal Reference Values"](#) .

2. If NG, recheck A/T assembly harness connector terminals for damage or loose connection with harness connector.

OK or NG

OK >> **INSPECTION END**

NG >> Repair or replace damaged parts.

# TROUBLE DIAGNOSIS FOR SYMPTOMS

UCS00483

## Large Shock (“N” to “D” Position)

### SYMPTOM:

A noticeable shock occurs when the selector lever is shifted from the “N” to “D” position.

### DIAGNOSTIC PROCEDURE

#### 1. CHECK SELF-DIAGNOSTIC RESULTS

Perform self-diagnosis. Refer to [AT-89, "SELF-DIAGNOSTIC RESULT MODE"](#) .

Is any malfunction detected by self-diagnostic results?

- YES >> Check the malfunctioning system. Refer to [AT-89, "SELF-DIAGNOSTIC RESULT MODE"](#) .
- NO >> GO TO 2.

#### 2. ENGINE IDLE SPEED

Check the engine idle speed. Refer to [EC-81, "Idle Speed and Ignition Timing Check"](#) (QR) or [EC-686, "Idle Speed and Ignition Timing Check"](#) (VQ).

OK or NG

- OK >> GO TO 3.
- NG >> Repair.

#### 3. CHECK CONTROL CABLE

Check the control cable.

- Refer to [AT-217, "Checking of A/T Position"](#) .

OK or NG

- OK >> GO TO 4.
- NG >> Adjust control cable. Refer to [AT-217, "Adjustment of A/T Position"](#) .

#### 4. CHECK A/T FLUID LEVEL

Check the A/T fluid level. Refer to [AT-12, "Checking the A/T Fluid \(ATF\)"](#) .

OK or NG

- OK >> GO TO 5.
- NG >> Refill ATF.

#### 5. CHECK LINE PRESSURE

Check line pressure at idle with selector lever in “D” position. Refer to [AT-53, "LINE PRESSURE TEST"](#) .

OK or NG

- OK >> GO TO 8.
- NG - 1 >> Line pressure high: GO TO 6.
- NG - 2 >> Line pressure low: GO TO 7.

#### 6. DETECT MALFUNCTIONING ITEM

1. Check control valve with TCM. Refer to [AT-228, "Control Valve With TCM and A/T Fluid Temperature Sensor 2"](#) .
2. Disassemble A/T. Refer to [AT-268, "DISASSEMBLY"](#) .
3. Check the following.
  - Oil pump assembly. Refer to [AT-285, "Oil Pump"](#) .

OK or NG

- OK >> GO TO 8.
- NG >> Repair or replace damaged parts.

# TROUBLE DIAGNOSIS FOR SYMPTOMS

---

## 7. DETECT MALFUNCTIONING ITEM

---

1. Check control valve with TCM. Refer to [AT-228, "Control Valve With TCM and A/T Fluid Temperature Sensor 2"](#) .
2. Disassemble A/T. Refer to [AT-268, "DISASSEMBLY"](#) .
3. Check the following.
  - Oil pump assembly. Refer to [AT-285, "Oil Pump"](#) .
  - Power train system. Refer to [AT-268, "DISASSEMBLY"](#) .
  - Transmission case. Refer to [AT-268, "DISASSEMBLY"](#) .

### OK or NG

- OK >> GO TO 8.  
NG >> Repair or replace damaged parts.

---

## 8. CHECK A/T FLUID CONDITION

---

1. Remove oil pan. Refer to [AT-228, "Control Valve With TCM and A/T Fluid Temperature Sensor 2"](#) .
2. Check A/T fluid condition. Refer to [AT-52, "Fluid Condition Check"](#) .

### OK or NG

- OK >> GO TO 10.  
NG >> GO TO 9.

---

## 9. DETECT MALFUNCTIONING ITEM

---

- Check the malfunction items. If any items are damaged, repair or replace damaged parts. Refer to [AT-64, "Symptom Chart"](#) (Symptom No. 1).

### OK or NG

- OK >> GO TO 10.  
NG >> Repair or replace damaged parts.

---

## 10. CHECK SYMPTOM

---

Check again. Refer to [AT-56, "Check at Idle"](#) .

### OK or NG

- OK >> **INSPECTION END**  
NG >> GO TO 11.

---

## 11. PERFORM TCM INSPECTION

---

1. Perform TCM input/output signals inspection. Refer to [AT-86, "TCM Input/Output Signal Reference Values"](#) .
2. If NG, recheck A/T assembly harness connector terminals for damage or loose connection with harness connector.

### OK or NG

- OK >> **INSPECTION END**  
NG >> Repair or replace damaged parts.

# TROUBLE DIAGNOSIS FOR SYMPTOMS

UCS00484

---

## Vehicle Does Not Creep Backward In “R” Position

### SYMPTOM:

The vehicle does not creep in the “R” position. Or an extreme lack of acceleration is observed.

### DIAGNOSTIC PROCEDURE

#### 1. CHECK SELF-DIAGNOSTIC RESULTS

---

Perform self-diagnosis. Refer to [AT-89, "SELF-DIAGNOSTIC RESULT MODE"](#) .

Is any malfunction detected by self-diagnostic results?

- YES >> Check the malfunctioning system. Refer to [AT-89, "SELF-DIAGNOSTIC RESULT MODE"](#) .
- NO >> GO TO 2.

#### 2. CHECK CONTROL CABLE

---

Check the control cable.

- Refer to [AT-217, "Checking of A/T Position"](#) .

OK or NG

- OK >> GO TO 3.
- NG >> Adjust control cable. Refer to [AT-217, "Adjustment of A/T Position"](#) .

#### 3. CHECK A/T FLUID LEVEL

---

Check A/T fluid level. Refer to [AT-12, "Checking the A/T Fluid \(ATF\)"](#) .

OK or NG

- OK >> GO TO 4.
- NG >> Refill ATF.

#### 4. CHECK STALL TEST

---

Check stall revolution with selector lever in “1” and “R” positions.

Refer to [AT-52, "STALL TEST"](#) .

OK or NG

- OK >> GO TO 6.
- OK in “1” position, NG in “R” position >> GO TO 5.
- NG in both “1” and “R” positions >> GO TO 8.

#### 5. DETECT MALFUNCTIONING ITEM

---

1. Disassemble A/T. Refer to [AT-268, "DISASSEMBLY"](#) .

2. Check the following items:

- Reverse brake. Refer to [AT-268, "DISASSEMBLY"](#) .

OK or NG

- OK >> GO TO 9.
- NG >> Repair or replace damaged parts.

#### 6. CHECK LINE PRESSURE

---

Check the line pressure with the engine idling. Refer to [AT-53, "LINE PRESSURE TEST"](#) .

OK or NG

- OK >> GO TO 9.
- NG - 1 >> Line pressure high. GO TO 7.
- NG - 2 >> Line pressure low. GO TO 8.



# TROUBLE DIAGNOSIS FOR SYMPTOMS

## 7. DETECT MALFUNCTIONING ITEM

1. Check control valve with TCM. Refer to [AT-228, "Control Valve With TCM and A/T Fluid Temperature Sensor 2"](#) .
2. Disassemble A/T. Refer to [AT-268, "DISASSEMBLY"](#) .
3. Check the following.
  - Oil pump assembly. Refer to [AT-285, "Oil Pump"](#) .

OK or NG

- OK >> GO TO 9.
- NG >> Repair or replace damaged parts.

## 8. DETECT MALFUNCTIONING ITEM

1. Check control valve with TCM. Refer to [AT-228, "Control Valve With TCM and A/T Fluid Temperature Sensor 2"](#) .
2. Disassemble A/T. Refer to [AT-268, "DISASSEMBLY"](#) .
3. Check the following.
  - Oil pump assembly. Refer to [AT-285, "Oil Pump"](#) .
  - Power train system. Refer to [AT-268, "DISASSEMBLY"](#) .
  - Transmission case. Refer to [AT-268, "DISASSEMBLY"](#) .

OK or NG

- OK >> GO TO 9.
- NG >> Repair or replace damaged parts.

## 9. CHECK A/T FLUID CONDITION

1. Remove oil pan. Refer to [AT-228, "Control Valve With TCM and A/T Fluid Temperature Sensor 2"](#) .
2. Check A/T fluid condition. Refer to [AT-52, "Fluid Condition Check"](#) .

OK or NG

- OK >> GO TO 10.
- NG >> GO TO 13.

## 10. DETECT MALFUNCTIONING ITEM

- Check the malfunction items. If any items are damaged, repair or replace damaged parts. Refer to [AT-64, "Symptom Chart"](#) (Symptom No. 43).

OK or NG

- OK >> GO TO 11.
- NG >> Repair or replace damaged parts.

## 11. CHECK SYMPTOM

Check again. Refer to [AT-56, "Check at Idle"](#) .

OK or NG

- OK >> **INSPECTION END**
- NG >> GO TO 12.

## 12. PERFORM TCM INSPECTION

1. Perform TCM input/output signals inspection. Refer to [AT-86, "TCM Input/Output Signal Reference Values"](#) .
2. If NG, recheck A/T assembly harness connector terminals for damage or loose connection with harness connector.

OK or NG

- OK >> **INSPECTION END**
- NG >> Repair or replace damaged parts.

## TROUBLE DIAGNOSIS FOR SYMPTOMS

---

### 13. DETECT MALFUNCTIONING ITEM

---

- Check the malfunction items. If any items are damaged, repair or replace damaged parts. Refer to [AT-64, "Symptom Chart"](#) (Symptom No. 43).

#### OK or NG

OK >> GO TO 11.

NG >> Repair or replace damaged parts.

# TROUBLE DIAGNOSIS FOR SYMPTOMS

UCS00485

## Vehicle Does Not Creep Forward In “D” Position

### SYMPTOM:

Vehicle does not creep forward when selecting “D” position.

### DIAGNOSTIC PROCEDURE

#### 1. CHECK SELF-DIAGNOSTIC RESULTS

Perform self-diagnosis. Refer to [AT-89, "SELF-DIAGNOSTIC RESULT MODE"](#) .

Is any malfunction detected by self-diagnostic results?

- YES >> Check the malfunctioning system. Refer to [AT-89, "SELF-DIAGNOSTIC RESULT MODE"](#) .
- NO >> GO TO 2.

#### 2. CHECK CONTROL CABLE

Check the control cable.

- Refer to [AT-217, "Checking of A/T Position"](#) .

OK or NG

- OK >> GO TO 3.
- NG >> Adjust control cable. Refer to [AT-217, "Adjustment of A/T Position"](#) .

#### 3. CHECK A/T FLUID LEVEL

Check A/T fluid level. Refer to [AT-12, "Checking the A/T Fluid \(ATF\)"](#) .

OK or NG

- OK >> GO TO 4.
- NG >> Refill ATF.

#### 4. CHECK STALL TEST

Check stall revolution with selector lever in “D” position. Refer to [AT-52, "STALL TEST"](#) .

OK or NG

- OK >> GO TO 5.
- NG >> GO TO 7.

#### 5. CHECK LINE PRESSURE

Check line pressure at idle with selector lever in “D” position. Refer to [AT-53, "LINE PRESSURE TEST"](#) .

OK or NG

- OK >> GO TO 8.
- NG - 1 >> Line pressure high. GO TO 6.
- NG - 2 >> Line pressure low. GO TO 7.

#### 6. DETECT MALFUNCTIONING ITEM

1. Check control valve with TCM. Refer to [AT-228, "Control Valve With TCM and A/T Fluid Temperature Sensor 2"](#) .
2. Disassemble A/T. Refer to [AT-268, "DISASSEMBLY"](#) .
3. Check the following items:
  - Oil pump assembly. Refer to [AT-285, "Oil Pump"](#) .

OK or NG

- OK >> GO TO 8.
- NG >> Repair or replace damaged parts.

# TROUBLE DIAGNOSIS FOR SYMPTOMS

---

## 7. DETECT MALFUNCTIONING ITEM

---

1. Check control valve with TCM. Refer to [AT-228, "Control Valve With TCM and A/T Fluid Temperature Sensor 2"](#) .
2. Disassemble A/T. Refer to [AT-268, "DISASSEMBLY"](#) .
3. Check the following.
  - Oil pump assembly. Refer to [AT-285, "Oil Pump"](#) .
  - Power train system. Refer to [AT-268, "DISASSEMBLY"](#) .
  - Transmission case. Refer to [AT-268, "DISASSEMBLY"](#) .

### OK or NG

- OK >> GO TO 8.  
NG >> Repair or replace damaged parts.

---

## 8. CHECK A/T FLUID CONDITION

---

1. Remove oil pan. Refer to [AT-228, "Control Valve With TCM and A/T Fluid Temperature Sensor 2"](#) .
2. Check A/T fluid condition. Refer to [AT-52, "Fluid Condition Check"](#) .

### OK or NG

- OK >> GO TO 9.  
NG >> GO TO 12.

---

## 9. DETECT MALFUNCTIONING ITEM

---

- Check the malfunction items. If any items are damaged, repair or replace damaged parts. Refer to [AT-64, "Symptom Chart"](#) (Symptom No. 43).

### OK or NG

- OK >> GO TO 10.  
NG >> Repair or replace damaged parts.

---

## 10. CHECK SYMPTOM

---

Check again. Refer to [AT-56, "Check at Idle"](#) .

### OK or NG

- OK >> **INSPECTION END**  
NG >> GO TO 11.

---

## 11. PERFORM TCM INSPECTION

---

1. Perform TCM input/output signals inspection. Refer to [AT-86, "TCM Input/Output Signal Reference Values"](#) .
2. If NG, recheck A/T assembly harness connector terminals for damage or loose connection with harness connector.

### OK or NG

- OK >> **INSPECTION END**  
NG >> Repair or replace damaged parts.

---

## 12. DETECT MALFUNCTIONING ITEM

---

- Check the malfunction items. If any items are damaged, repair or replace damaged parts. Refer to [AT-64, "Symptom Chart"](#) (Symptom No. 43).

### OK or NG

- OK >> GO TO 10.  
NG >> Repair or replace damaged parts.

# TROUBLE DIAGNOSIS FOR SYMPTOMS

UCS00486

## Vehicle Cannot Be Started From D1

### SYMPTOM:

Vehicle cannot be started from D1 on cruise test - Part 1 and cruise test - Part 2.

### DIAGNOSTIC PROCEDURE

#### 1. CONFIRM THE SYMPTOM

Check if vehicle creeps in "R" position.

OK or NG

OK >> GO TO 2.

NG >> Refer to [AT-184, "Vehicle Does Not Creep Backward In "R" Position"](#) .

#### 2. CHECK SELF-DIAGNOSTIC RESULTS

Perform self-diagnosis. Refer to [AT-89, "SELF-DIAGNOSTIC RESULT MODE"](#) .

Is any malfunction detected by self-diagnostic results?

YES >> Check the malfunctioning system. Refer to [AT-89, "SELF-DIAGNOSTIC RESULT MODE"](#) .

NO >> GO TO 3.

#### 3. CHECK ACCELERATOR PEDAL POSITION (APP) SENSOR

Check accelerator pedal position (APP) sensor. Refer to [AT-125, "DTC P1705 THROTTLE POSITION SENSOR"](#) .

OK or NG

OK >> GO TO 4.

NG >> Repair or replace accelerator pedal position (APP) sensor.

#### 4. CHECK A/T FLUID LEVEL

Check A/T fluid level. Refer to [AT-12, "Checking the A/T Fluid \(ATF\)"](#) .

OK or NG

OK >> GO TO 5.

NG >> Refill ATF.

#### 5. CHECK LINE PRESSURE

Check line pressure at the engine stall point. Refer to [AT-53, "LINE PRESSURE TEST"](#) .

OK or NG

OK >> GO TO 8.

NG - 1 >> Line pressure high. GO TO 6.

NG - 2 >> Line pressure low. GO TO 7.

#### 6. DETECT MALFUNCTIONING ITEM

1. Check control valve with TCM. Refer to [AT-228, "Control Valve With TCM and A/T Fluid Temperature Sensor 2"](#) .

2. Disassemble A/T. Refer to [AT-268, "DISASSEMBLY"](#) .

3. Check the following.

- Oil pump assembly. Refer to [AT-285, "Oil Pump"](#) .

OK or NG

OK >> GO TO 8.

NG >> Repair or replace damaged parts.

# TROUBLE DIAGNOSIS FOR SYMPTOMS

---

## 7. DETECT MALFUNCTIONING ITEM

---

1. Check control valve with TCM. Refer to [AT-228, "Control Valve With TCM and A/T Fluid Temperature Sensor 2"](#) .
2. Disassemble A/T. Refer to [AT-268, "DISASSEMBLY"](#) .
3. Check the following.
  - Oil pump assembly. Refer to [AT-285, "Oil Pump"](#) .
  - Power train system. Refer to [AT-268, "DISASSEMBLY"](#) .
  - Transmission case. Refer to [AT-268, "DISASSEMBLY"](#) .

### OK or NG

- OK >> GO TO 8.  
NG >> Repair or replace damaged parts.

---

## 8. CHECK A/T FLUID CONDITION

---

1. Remove oil pan. Refer to [AT-228, "Control Valve With TCM and A/T Fluid Temperature Sensor 2"](#) .
2. Check A/T fluid condition. Refer to [AT-52, "Fluid Condition Check"](#) .

### OK or NG

- OK >> GO TO 9.  
NG >> GO TO 12.

---

## 9. DETECT MALFUNCTIONING ITEM

---

- Check the malfunction items. If any items are damaged, repair or replace damaged parts. Refer to [AT-64, "Symptom Chart"](#) (Symptom No. 23).

### OK or NG

- OK >> GO TO 10.  
NG >> Repair or replace damaged parts.

---

## 10. CHECK SYMPTOM

---

Check again. Refer to [AT-57, "Cruise Test - Part 1"](#) , [AT-59, "Cruise Test - Part 2"](#) .

### OK or NG

- OK >> **INSPECTION END**  
NG >> GO TO 11.

---

## 11. PERFORM TCM INSPECTION

---

1. Perform TCM input/output signals inspection. Refer to [AT-86, "TCM Input/Output Signal Reference Values"](#) .
2. If NG, recheck A/T assembly harness connector terminals for damage or loose connection with harness connector.

### OK or NG

- OK >> **INSPECTION END**  
NG >> Repair or replace damaged parts.

---

## 12. DETECT MALFUNCTIONING ITEM

---

- Check the malfunction items. If any items are damaged, repair or replace damaged parts. Refer to [AT-64, "Symptom Chart"](#) (Symptom No. 23).

### OK or NG

- OK >> GO TO 10.  
NG >> Repair or replace damaged parts.

# TROUBLE DIAGNOSIS FOR SYMPTOMS

UCS00487

## A/T Does Not Shift: D1 → D2

### SYMPTOM:

The vehicle does not shift-up from the D1 to D2 gear at the specified speed.

### DIAGNOSTIC PROCEDURE

#### 1. CONFIRM THE SYMPTOM

Check if vehicle creeps forward in "D" position and vehicle can be started from D1.

OK or NG

OK >> GO TO 2.

NG >> Refer to [AT-187, "Vehicle Does Not Creep Forward In "D" Position"](#) , [AT-189, "Vehicle Cannot Be Started From D1"](#) .

#### 2. CHECK SELF-DIAGNOSTIC RESULTS

Perform self-diagnosis. Refer to [AT-89, "SELF-DIAGNOSTIC RESULT MODE"](#) .

Is any malfunction detected by self-diagnostic results?

YES >> Check the malfunctioning system. Refer to [AT-89, "SELF-DIAGNOSTIC RESULT MODE"](#) .

NO >> GO TO 3.

#### 3. CHECK A/T FLUID LEVEL

Check A/T fluid level. Refer to [AT-12, "Checking the A/T Fluid \(ATF\)"](#) .

OK or NG

OK >> GO TO 4.

NG >> Refill ATF.

#### 4. CHECK LINE PRESSURE

Check line pressure at the engine stall point. Refer to [AT-53, "LINE PRESSURE TEST"](#) .

OK or NG

OK >> GO TO 7.

NG - 1 >> Line pressure high. GO TO 5.

NG - 2 >> Line pressure low. GO TO 6.

#### 5. DETECT MALFUNCTIONING ITEM

1. Check control valve with TCM. Refer to [AT-228, "Control Valve With TCM and A/T Fluid Temperature Sensor 2"](#) .

2. Disassemble A/T. Refer to [AT-268, "DISASSEMBLY"](#) .

3. Check the following.

- Oil pump assembly. Refer to [AT-285, "Oil Pump"](#) .

OK or NG

OK >> GO TO 7.

NG >> Repair or replace damaged parts.

# TROUBLE DIAGNOSIS FOR SYMPTOMS

---

## 6. DETECT MALFUNCTIONING ITEM

---

1. Check control valve with TCM. Refer to [AT-228, "Control Valve With TCM and A/T Fluid Temperature Sensor 2"](#) .
2. Disassemble A/T. Refer to [AT-268, "DISASSEMBLY"](#) .
3. Check the following.
  - Oil pump assembly. Refer to [AT-285, "Oil Pump"](#) .
  - Power train system. Refer to [AT-268, "DISASSEMBLY"](#) .
  - Transmission case. Refer to [AT-268, "DISASSEMBLY"](#) .

### OK or NG

- OK >> GO TO 7.  
NG >> Repair or replace damaged parts.

---

## 7. CHECK A/T FLUID CONDITION

---

1. Remove oil pan. Refer to [AT-228, "Control Valve With TCM and A/T Fluid Temperature Sensor 2"](#) .
2. Check A/T fluid condition. Refer to [AT-52, "Fluid Condition Check"](#) .

### OK or NG

- OK >> GO TO 8.  
NG >> GO TO 11.

---

## 8. DETECT MALFUNCTIONING ITEM

---

- Check the malfunction items. If any items are damaged, repair or replace damaged parts. Refer to [AT-64, "Symptom Chart"](#) (Symptom No. 10).

### OK or NG

- OK >> GO TO 9.  
NG >> Repair or replace damaged parts.

---

## 9. CHECK SYMPTOM

---

Check again. Refer to [AT-57, "Cruise Test - Part 1"](#) , [AT-59, "Cruise Test - Part 2"](#) .

### OK or NG

- OK >> **INSPECTION END**  
NG >> GO TO 10.

---

## 10. PERFORM TCM INSPECTION

---

1. Perform TCM input/output signals inspection. Refer to [AT-86, "TCM Input/Output Signal Reference Values"](#) .
2. If NG, recheck A/T assembly harness connector terminals for damage or loose connection with harness connector.

### OK or NG

- OK >> **INSPECTION END**  
NG >> Repair or replace damaged parts.

---

## 11. DETECT MALFUNCTIONING ITEM

---

- Check the malfunction items. If any items are damaged, repair or replace damaged parts. Refer to [AT-64, "Symptom Chart"](#) (Symptom No. 10).

### OK or NG

- OK >> GO TO 9.  
NG >> Repair or replace damaged parts.



# TROUBLE DIAGNOSIS FOR SYMPTOMS

UCS00488

## A/T Does Not Shift: D2 → D3

### SYMPTOM:

The vehicle does not shift-up from D2 to D3 gear at the specified speed.

### DIAGNOSTIC PROCEDURE

#### 1. CONFIRM THE SYMPTOM

Check if vehicle creeps forward in "D" position and vehicle can be started from D1.

OK or NG

OK >> GO TO 2.

NG >> Refer to [AT-187, "Vehicle Does Not Creep Forward In "D" Position"](#) , [AT-189, "Vehicle Cannot Be Started From D1"](#) .

#### 2. CHECK SELF-DIAGNOSTIC RESULTS

Perform self-diagnosis. Refer to [AT-89, "SELF-DIAGNOSTIC RESULT MODE"](#) .

Is any malfunction detected by self-diagnostic results?

YES >> Check the malfunctioning system. Refer to [AT-89, "SELF-DIAGNOSTIC RESULT MODE"](#) .

NO >> GO TO 3.

#### 3. CHECK A/T FLUID LEVEL

Check A/T fluid level. Refer to [AT-12, "Checking the A/T Fluid \(ATF\)"](#) .

OK or NG

OK >> GO TO 4.

NG >> Refill ATF.

#### 4. CHECK LINE PRESSURE

Check line pressure at the engine stall point. Refer to [AT-53, "LINE PRESSURE TEST"](#) .

OK or NG

OK >> GO TO 7.

NG - 1 >> Line pressure high. GO TO 5.

NG - 2 >> Line pressure low. GO TO 6.

#### 5. DETECT MALFUNCTIONING ITEM

1. Check control valve with TCM. Refer to [AT-228, "Control Valve With TCM and A/T Fluid Temperature Sensor 2"](#) .

2. Disassemble A/T. Refer to [AT-268, "DISASSEMBLY"](#) .

3. Check the following.

- Oil pump assembly. Refer to [AT-285, "Oil Pump"](#) .

OK or NG

OK >> GO TO 7.

NG >> Repair or replace damaged parts.

## TROUBLE DIAGNOSIS FOR SYMPTOMS

---

### 6. DETECT MALFUNCTIONING ITEM

---

1. Check control valve with TCM. Refer to [AT-228, "Control Valve With TCM and A/T Fluid Temperature Sensor 2"](#) .
2. Disassemble A/T. Refer to [AT-268, "DISASSEMBLY"](#) .
3. Check the following.
  - Oil pump assembly. Refer to [AT-285, "Oil Pump"](#) .
  - Power train system. Refer to [AT-268, "DISASSEMBLY"](#) .
  - Transmission case. Refer to [AT-268, "DISASSEMBLY"](#) .

#### OK or NG

- OK >> GO TO 7.  
NG >> Repair or replace damaged parts.

---

### 7. CHECK A/T FLUID CONDITION

---

1. Remove oil pan. Refer to [AT-228, "Control Valve With TCM and A/T Fluid Temperature Sensor 2"](#) .
2. Check A/T fluid condition. Refer to [AT-52, "Fluid Condition Check"](#) .

#### OK or NG

- OK >> GO TO 8.  
NG >> GO TO 11.

---

### 8. DETECT MALFUNCTIONING ITEM

---

- Check the malfunction items. If any items are damaged, repair or replace damaged parts. Refer to [AT-64, "Symptom Chart"](#) (Symptom No. 11).

#### OK or NG

- OK >> GO TO 9.  
NG >> Repair or replace damaged parts.

---

### 9. CHECK SYMPTOM

---

Check again. Refer to [AT-57, "Cruise Test - Part 1"](#) , [AT-59, "Cruise Test - Part 2"](#) .

#### OK or NG

- OK >> **INSPECTION END**  
NG >> GO TO 10.

---

### 10. PERFORM TCM INSPECTION

---

1. Perform TCM input/output signals inspection. Refer to [AT-86, "TCM Input/Output Signal Reference Values"](#) .
2. If NG, recheck A/T assembly harness connector terminals for damage or loose connection with harness connector.

#### OK or NG

- OK >> **INSPECTION END**  
NG >> Repair or replace damaged parts.

---

### 11. DETECT MALFUNCTIONING ITEM

---

- Check the malfunction items. If any items are damaged, repair or replace damaged parts. Refer to [AT-64, "Symptom Chart"](#) (Symptom No. 11).

#### OK or NG

- OK >> GO TO 9.  
NG >> Repair or replace damaged parts.

# TROUBLE DIAGNOSIS FOR SYMPTOMS

UCS00489

## A/T Does Not Shift: D3 → D4

### SYMPTOM:

- The vehicle does not shift-up from the D3 to D4 gear at the specified speed.
- The vehicle does not shift-up from the D3 to D4 gear unless A/T is warmed up.

### DIAGNOSTIC PROCEDURE

#### 1. CONFIRM THE SYMPTOM

Check if vehicle creeps forward in "D" position and vehicle can be started from D1.

OK or NG

OK >> GO TO 2.

NG >> Refer to [AT-187, "Vehicle Does Not Creep Forward In "D" Position"](#) , [AT-189, "Vehicle Cannot Be Started From D1"](#) .

#### 2. CHECK SELF-DIAGNOSTIC RESULTS

Perform self-diagnosis. Refer to [AT-89, "SELF-DIAGNOSTIC RESULT MODE"](#) .

Is any malfunction detected by self-diagnostic results?

YES >> Check the malfunctioning system. Refer to [AT-89, "SELF-DIAGNOSTIC RESULT MODE"](#) .

NO >> GO TO 3.

#### 3. CHECK A/T FLUID LEVEL

Check A/T fluid level. Refer to [AT-12, "Checking the A/T Fluid \(ATF\)"](#) .

OK or NG

OK >> GO TO 4.

NG >> Refill ATF.

#### 4. CHECK LINE PRESSURE

Check line pressure at the engine stall point. Refer to [AT-53, "LINE PRESSURE TEST"](#) .

OK or NG

OK >> GO TO 7.

NG - 1 >> Line pressure high. GO TO 5.

NG - 2 >> Line pressure low. GO TO 6.

#### 5. DETECT MALFUNCTIONING ITEM

1. Check control valve with TCM. Refer to [AT-228, "Control Valve With TCM and A/T Fluid Temperature Sensor 2"](#) .

2. Disassemble A/T. Refer to [AT-268, "DISASSEMBLY"](#) .

3. Check the following.

- Oil pump assembly. Refer to [AT-285, "Oil Pump"](#) .

OK or NG

OK >> GO TO 7.

NG >> Repair or replace damaged parts.

# TROUBLE DIAGNOSIS FOR SYMPTOMS

---

## 6. DETECT MALFUNCTIONING ITEM

---

1. Check control valve with TCM. Refer to [AT-228, "Control Valve With TCM and A/T Fluid Temperature Sensor 2"](#) .
2. Disassemble A/T. Refer to [AT-268, "DISASSEMBLY"](#) .
3. Check the following.
  - Oil pump assembly. Refer to [AT-285, "Oil Pump"](#) .
  - Power train system. Refer to [AT-268, "DISASSEMBLY"](#) .
  - Transmission case. Refer to [AT-268, "DISASSEMBLY"](#) .

### OK or NG

- OK >> GO TO 7.  
NG >> Repair or replace damaged parts.

---

## 7. CHECK A/T FLUID CONDITION

---

1. Remove oil pan. Refer to [AT-228, "Control Valve With TCM and A/T Fluid Temperature Sensor 2"](#) .
2. Check A/T fluid condition. Refer to [AT-52, "Fluid Condition Check"](#) .

### OK or NG

- OK >> GO TO 8.  
NG >> GO TO 11.

---

## 8. DETECT MALFUNCTIONING ITEM

---

- Check the malfunction items. If any items are damaged, repair or replace damaged parts. Refer to [AT-64, "Symptom Chart"](#) (Symptom No. 12).

### OK or NG

- OK >> GO TO 9.  
NG >> Repair or replace damaged parts.

---

## 9. CHECK SYMPTOM

---

Check again. Refer to [AT-57, "Cruise Test - Part 1"](#) , [AT-59, "Cruise Test - Part 2"](#) .

### OK or NG

- OK >> **INSPECTION END**  
NG >> GO TO 10.

---

## 10. PERFORM TCM INSPECTION

---

1. Perform TCM input/output signals inspection. Refer to [AT-86, "TCM Input/Output Signal Reference Values"](#) .
2. If NG, recheck A/T assembly harness connector terminals for damage or loose connection with harness connector.

### OK or NG

- OK >> **INSPECTION END**  
NG >> Repair or replace damaged parts.

---

## 11. DETECT MALFUNCTIONING ITEM

---

- Check the malfunction items. If any items are damaged, repair or replace damaged parts. Refer to [AT-64, "Symptom Chart"](#) (Symptom No. 12).

### OK or NG

- OK >> GO TO 9.  
NG >> Repair or replace damaged parts.

# TROUBLE DIAGNOSIS FOR SYMPTOMS

UCS0048A

## A/T Does Not Shift: D4 → D5

### SYMPTOM:

- The vehicle does not shift-up from the D4 to D5 gear at the specified speed.
- The vehicle does not shift-up from the D4 to D5 gear unless A/T is warmed up.

### DIAGNOSTIC PROCEDURE

#### 1. CONFIRM THE SYMPTOM

Check if vehicle creeps forward in "D" position and vehicle can be started from D1.

##### OK or NG

OK >> GO TO 2.

NG >> Refer to [AT-187, "Vehicle Does Not Creep Forward In "D" Position"](#) , [AT-189, "Vehicle Cannot Be Started From D1"](#) .

#### 2. CHECK SELF-DIAGNOSTIC RESULTS

Perform self-diagnosis. Refer to [AT-89, "SELF-DIAGNOSTIC RESULT MODE"](#) .

Is any malfunction detected by self-diagnostic results?

YES >> Check the malfunctioning system. Refer to [AT-89, "SELF-DIAGNOSTIC RESULT MODE"](#) .

NO >> GO TO 3.

#### 3. CHECK A/T FLUID LEVEL

Check A/T fluid level. Refer to [AT-12, "Checking the A/T Fluid \(ATF\)"](#) .

##### OK or NG

OK >> GO TO 4.

NG >> Refill ATF.

#### 4. CHECK LINE PRESSURE

Check line pressure at the engine stall point. Refer to [AT-53, "LINE PRESSURE TEST"](#) .

##### OK or NG

OK >> GO TO 7.

NG - 1 >> Line pressure high. GO TO 5.

NG - 2 >> Line pressure low. GO TO 6.

#### 5. DETECT MALFUNCTIONING ITEM

1. Check control valve with TCM. Refer to [AT-228, "Control Valve With TCM and A/T Fluid Temperature Sensor 2"](#) .

2. Disassemble A/T. Refer to [AT-268, "DISASSEMBLY"](#) .

3. Check the following.

- Oil pump assembly. Refer to [AT-285, "Oil Pump"](#) .

##### OK or NG

OK >> GO TO 7.

NG >> Repair or replace damaged parts.

## TROUBLE DIAGNOSIS FOR SYMPTOMS

---

### 6. DETECT MALFUNCTIONING ITEM

---

1. Check control valve with TCM. Refer to [AT-228, "Control Valve With TCM and A/T Fluid Temperature Sensor 2"](#) .
2. Disassemble A/T. Refer to [AT-268, "DISASSEMBLY"](#) .
3. Check the following.
  - Oil pump assembly. Refer to [AT-285, "Oil Pump"](#) .
  - Power train system. Refer to [AT-268, "DISASSEMBLY"](#) .
  - Transmission case. Refer to [AT-268, "DISASSEMBLY"](#) .

#### OK or NG

- OK >> GO TO 7.  
NG >> Repair or replace damaged parts.

---

### 7. CHECK A/T FLUID CONDITION

---

1. Remove oil pan. Refer to [AT-228, "Control Valve With TCM and A/T Fluid Temperature Sensor 2"](#) .
2. Check A/T fluid condition. Refer to [AT-52, "Fluid Condition Check"](#) .

#### OK or NG

- OK >> GO TO 8.  
NG >> GO TO 11.

---

### 8. DETECT MALFUNCTIONING ITEM

---

- Check the malfunction items. If any items are damaged, repair or replace damaged parts. Refer to [AT-64, "Symptom Chart"](#) (Symptom No. 13).

#### OK or NG

- OK >> GO TO 9.  
NG >> Repair or replace damaged parts.

---

### 9. CHECK SYMPTOM

---

Check again. Refer to [AT-57, "Cruise Test - Part 1"](#) .

#### OK or NG

- OK >> **INSPECTION END**  
NG >> GO TO 10.

---

### 10. PERFORM TCM INSPECTION

---

1. Perform TCM input/output signals inspection. Refer to [AT-86, "TCM Input/Output Signal Reference Values"](#) .
2. If NG, recheck A/T assembly harness connector terminals for damage or loose connection with harness connector.

#### OK or NG

- OK >> **INSPECTION END**  
NG >> Repair or replace damaged parts.

---

### 11. DETECT MALFUNCTIONING ITEM

---

- Check the malfunction items. If any items are damaged, repair or replace damaged parts. Refer to [AT-64, "Symptom Chart"](#) (Symptom No. 13).

#### OK or NG

- OK >> GO TO 9.  
NG >> Repair or replace damaged parts.

# TROUBLE DIAGNOSIS FOR SYMPTOMS

UCS0048B

## A/T Does Not Perform Lock-up

### SYMPTOM:

A/T does not perform lock-up at the specified speed.

### DIAGNOSTIC PROCEDURE

#### 1. CHECK SELF-DIAGNOSTIC RESULTS

Perform self-diagnosis. Refer to [AT-89, "SELF-DIAGNOSTIC RESULT MODE"](#) .

Is any malfunction detected by self-diagnostic results?

- YES >> Check the malfunctioning system. Refer to [AT-89, "SELF-DIAGNOSTIC RESULT MODE"](#) .
- NO >> GO TO 2.

#### 2. CHECK A/T FLUID LEVEL

Check A/T fluid level. Refer to [AT-12, "Checking the A/T Fluid \(ATF\)"](#) .

OK or NG

- OK >> GO TO 3.
- NG >> Refill ATF.

#### 3. CHECK LINE PRESSURE

Check line pressure at the engine stall point. Refer to [AT-53, "LINE PRESSURE TEST"](#) .

OK or NG

- OK >> GO TO 6.
- NG - 1 >> Line pressure high. GO TO 4.
- NG - 2 >> Line pressure low. GO TO 5.

#### 4. DETECT MALFUNCTIONING ITEM

1. Check control valve with TCM. Refer to [AT-228, "Control Valve With TCM and A/T Fluid Temperature Sensor 2"](#) .
2. Disassemble A/T. Refer to [AT-268, "DISASSEMBLY"](#) .
3. Check the following.
  - Oil pump assembly. Refer to [AT-285, "Oil Pump"](#) .

OK or NG

- OK >> GO TO 7.
- NG >> Repair or replace damaged parts.

#### 5. DETECT MALFUNCTIONING ITEM

1. Check control valve with TCM. Refer to [AT-228, "Control Valve With TCM and A/T Fluid Temperature Sensor 2"](#) .
2. Disassemble A/T. Refer to [AT-268, "DISASSEMBLY"](#) .
3. Check the following.
  - Oil pump assembly. Refer to [AT-285, "Oil Pump"](#) .
  - Power train system. Refer to [AT-268, "DISASSEMBLY"](#) .
  - Transmission case. Refer to [AT-268, "DISASSEMBLY"](#) .

OK or NG

- OK >> GO TO 7.
- NG >> Repair or replace damaged parts.

# TROUBLE DIAGNOSIS FOR SYMPTOMS

---

## 6. CHECK A/T FLUID CONDITION

---

1. Remove oil pan. Refer to [AT-228, "Control Valve With TCM and A/T Fluid Temperature Sensor 2"](#) .
2. Check A/T fluid condition. Refer to [AT-52, "Fluid Condition Check"](#) .

OK or NG

- OK >> GO TO 7.  
NG >> GO TO 10.

## 7. DETECT MALFUNCTIONING ITEM

---

- Check the malfunction items. If any items are damaged, repair or replace damaged parts. Refer to [AT-64, "Symptom Chart"](#) (Symptom No. 24).

OK or NG

- OK >> GO TO 8.  
NG >> Repair or replace damaged parts.

## 8. CHECK SYMPTOM

---

Check again. Refer to [AT-57, "Cruise Test - Part 1"](#) .

OK or NG

- OK >> **INSPECTION END**  
NG >> GO TO 9.

## 9. PERFORM TCM INSPECTION

---

1. Perform TCM input/output signals inspection. Refer to [AT-86, "TCM Input/Output Signal Reference Values"](#) .
2. If NG, recheck A/T assembly harness connector terminals for damage or loose connection with harness connector.

OK or NG

- OK >> **INSPECTION END**  
NG >> Repair or replace damaged parts.

## 10. DETECT MALFUNCTIONING ITEM

---

- Check the malfunction items. If any items are damaged, repair or replace damaged parts. Refer to [AT-64, "Symptom Chart"](#) (Symptom No. 24).

OK or NG

- OK >> GO TO 8.  
NG >> Repair or replace damaged parts.



# TROUBLE DIAGNOSIS FOR SYMPTOMS

UCS0048C

## A/T Does Not Hold Lock-up Condition

### SYMPTOM:

The lock-up condition cannot be maintained for more than 30 seconds.

### DIAGNOSTIC PROCEDURE

#### 1. CHECK SELF-DIAGNOSTIC RESULTS

Perform self-diagnosis. Refer to [AT-89, "SELF-DIAGNOSTIC RESULT MODE"](#) .

Is any malfunction detected by self-diagnostic results?

- YES >> Check the malfunctioning system. Refer to [AT-89, "SELF-DIAGNOSTIC RESULT MODE"](#) .  
NO >> GO TO 2.

#### 2. CHECK A/T FLUID LEVEL

Check A/T fluid level. Refer to [AT-12, "Checking the A/T Fluid \(ATF\)"](#) .

OK or NG

- OK >> GO TO 3.  
NG >> Refill ATF.

#### 3. CHECK A/T FLUID CONDITION

1. Remove oil pan. Refer to [AT-228, "Control Valve With TCM and A/T Fluid Temperature Sensor 2"](#) .
2. Check A/T fluid condition. Refer to [AT-52, "Fluid Condition Check"](#) .

OK or NG

- OK >> GO TO 4.  
NG >> GO TO 7.

#### 4. DETECT MALFUNCTIONING ITEM

- Check the malfunction items. If any items are damaged, repair or replace damaged parts. Refer to [AT-64, "Symptom Chart"](#) (Symptom No. 25).

OK or NG

- OK >> GO TO 5.  
NG >> Repair or replace damaged parts.

#### 5. CHECK SYMPTOM

Check again. Refer to [AT-57, "Cruise Test - Part 1"](#) .

OK or NG

- OK >> **INSPECTION END**  
NG >> GO TO 6.

#### 6. PERFORM TCM INSPECTION

1. Perform TCM input/output signals inspection. Refer to [AT-86, "TCM Input/Output Signal Reference Values"](#) .
2. If NG, recheck A/T assembly harness connector terminals for damage or loose connection with harness connector.

OK or NG

- OK >> **INSPECTION END**  
NG >> Repair or replace damaged parts.

## TROUBLE DIAGNOSIS FOR SYMPTOMS

---

### 7. DETECT MALFUNCTIONING ITEM

---

- Check the malfunction items. If any items are damaged, repair or replace damaged parts. Refer to [AT-64, "Symptom Chart"](#) (Symptom No. 25).

#### OK or NG

OK >> GO TO 5.

NG >> Repair or replace damaged parts.

# TROUBLE DIAGNOSIS FOR SYMPTOMS

UCS0048D

## Lock-up Is Not Released

### SYMPTOM:

The lock-up condition cannot be cancelled even after releasing the accelerator pedal.

### DIAGNOSTIC PROCEDURE

#### 1. CHECK SELF-DIAGNOSTIC RESULTS

Perform self-diagnosis. Refer to [AT-89, "SELF-DIAGNOSTIC RESULT MODE"](#) .

Is any malfunction detected by self-diagnostic results?

- YES >> Check the malfunctioning system. Refer to [AT-89, "SELF-DIAGNOSTIC RESULT MODE"](#) .  
NO >> GO TO 2.

#### 2. CHECK SYMPTOM

Check again. Refer to [AT-57, "Cruise Test - Part 1"](#) .

OK or NG

- OK >> **INSPECTION END**  
NG >> GO TO 3.

#### 3. PERFORM TCM INSPECTION

1. Perform TCM input/output signals inspection. Refer to [AT-86, "TCM Input/Output Signal Reference Values"](#) .
2. If NG, recheck A/T assembly harness connector terminals for damage or loose connection with harness connector.

OK or NG

- OK >> **INSPECTION END**  
NG >> Repair or replace damaged parts.

A

B

AT

D

E

F

G

H

I

J

K

L

M

# TROUBLE DIAGNOSIS FOR SYMPTOMS

UCS0048E

## Engine Speed Does Not Return to Idle

### SYMPTOM:

When a shift-down is performed, the engine speed does not smoothly return to the idling speed.

### DIAGNOSTIC PROCEDURE

#### 1. CHECK A/T FLUID LEVEL

Check A/T fluid level. Refer to [AT-12, "Checking the A/T Fluid \(ATF\)"](#) .

##### OK or NG

- OK >> GO TO 2.
- NG >> Refill ATF.

#### 2. CHECK SELF-DIAGNOSTIC RESULTS

Perform self-diagnosis. Refer to [AT-89, "SELF-DIAGNOSTIC RESULT MODE"](#) .

Is any malfunction detected by self-diagnostic results?

- YES >> Check the malfunctioning system. Refer to [AT-89, "SELF-DIAGNOSTIC RESULT MODE"](#) .
- NO >> GO TO 3.

#### 3. CHECK A/T FLUID CONDITION

1. Remove oil pan. Refer to [AT-228, "Control Valve With TCM and A/T Fluid Temperature Sensor 2"](#) .
2. Check A/T fluid condition. Refer to [AT-52, "Fluid Condition Check"](#) .

##### OK or NG

- OK >> GO TO 4.
- NG >> GO TO 7.

#### 4. DETECT MALFUNCTIONING ITEM

- Check the malfunction items. If any items are damaged, repair or replace damaged parts. Refer to [AT-64, "Symptom Chart"](#) (Symptom No. 65).

##### OK or NG

- OK >> GO TO 5.
- NG >> Repair or replace damaged parts.

#### 5. CHECK SYMPTOM

Check again. Refer to [AT-57, "Cruise Test - Part 1"](#) .

##### OK or NG

- OK >> **INSPECTION END**
- NG >> GO TO 6.

#### 6. PERFORM TCM INSPECTION

1. Perform TCM input/output signals inspection. Refer to [AT-86, "TCM Input/Output Signal Reference Values"](#) .
2. If NG, recheck A/T assembly harness connector terminals for damage or loose connection with harness connector.

##### OK or NG

- OK >> **INSPECTION END**
- NG >> Repair or replace damaged parts.

# TROUBLE DIAGNOSIS FOR SYMPTOMS

---

## 7. DETECT MALFUNCTIONING ITEM

---

- Check the malfunction items. If any items are damaged, repair or replace damaged parts. Refer to [AT-64, "Symptom Chart"](#) (Symptom No. 65).

OK or NG

OK >> GO TO 5.

NG >> Repair or replace damaged parts.

A

B

AT

D

E

F

G

H

I

J

K

L

M

# TROUBLE DIAGNOSIS FOR SYMPTOMS

UCS0048F

---

## A/T Does Not Shift: 5th gear → 4th gear

### SYMPTOM:

A/T does not shift from D5 to D4 when changing overdrive control switch to OFF position.

### DIAGNOSTIC PROCEDURE

---

#### 1. CHECK SELF-DIAGNOSIS RESULTS

Perform self-diagnosis. Refer to [AT-89, "SELF-DIAGNOSTIC RESULT MODE"](#) .

Is any malfunction detected by self-diagnostic results?

- YES >> Check the malfunctioning system. Refer to [AT-89, "SELF-DIAGNOSTIC RESULT MODE"](#) .
- NO >> GO TO 2.

---

#### 2. CHECK OVERDRIVE CONTROL SWITCH CIRCUIT

Check overdrive control switch. Refer to [AT-174, "OVERDRIVE CONTROL SWITCH"](#) .

OK or NG

- OK >> GO TO 3.
- NG >> Repair or replace damaged parts.

---

#### 3. CHECK A/T FLUID LEVEL

Check the A/T fluid level. Refer to [AT-12, "Checking the A/T Fluid \(ATF\)"](#) .

OK or NG

- OK >> GO TO 4.
- NG >> Refill ATF.

---

#### 4. CHECK CONTROL CABLE

Check the control cable.

- Refer to [AT-217, "Checking of A/T Position"](#) .

OK or NG

- OK >> GO TO 5.
- NG >> Adjust control cable. Refer to [AT-217, "Adjustment of A/T Position"](#) .

---

#### 5. CHECK A/T FLUID CONDITION

1. Remove oil pan. Refer to [AT-228, "Control Valve With TCM and A/T Fluid Temperature Sensor 2"](#) .
2. Check A/T fluid condition. Refer to [AT-52, "Fluid Condition Check"](#) .

OK or NG

- OK >> GO TO 6.
- NG >> GO TO 9.

---

#### 6. DETECT MALFUNCTIONING ITEM

- Check the malfunction items. If any items are damaged, repair or replace damaged parts. Refer to [AT-64, "Symptom Chart"](#) (Symptom No. 14).

OK or NG

- OK >> GO TO 7.
- NG >> Repair or replace damaged parts.

---

#### 7. CHECK SYMPTOM

Check again. Refer to [AT-60, "Cruise Test - Part 3"](#) .

OK or NG

- OK >> **INSPECTION END**
- NG >> GO TO 8.

# TROUBLE DIAGNOSIS FOR SYMPTOMS

---

## 8. PERFORM TCM INSPECTION

---

1. Perform TCM input/output signals inspection. Refer to [AT-86, "TCM Input/Output Signal Reference Values"](#) .
2. If NG, recheck A/T assembly harness connector terminals for damage or loose connection with harness connector.

OK or NG

- OK >> **INSPECTION END**  
NG >> Repair or replace damaged parts.

## 9. DETECT MALFUNCTIONING ITEM

---

- Check the malfunction items. If any items are damaged, repair or replace damaged parts. Refer to [AT-64, "Symptom Chart"](#) (Symptom No. 14).

OK or NG

- OK >> GO TO 7.  
NG >> Repair or replace damaged parts.

A  
B  
AT  
D  
E  
F  
G  
H  
I  
J  
K  
L  
M

# TROUBLE DIAGNOSIS FOR SYMPTOMS

UCS0048G

---

## A/T Does Not Shift: 4th gear → 3rd gear

### SYMPTOM:

When shifted from D to 3 position, does not downshift from 4th to 3rd gears.

### DIAGNOSTIC PROCEDURE

#### 1. CHECK SELF-DIAGNOSIS RESULTS

---

Perform self-diagnosis. Refer to [AT-89, "SELF-DIAGNOSTIC RESULT MODE"](#) .

Is any malfunction detected by self-diagnostic results?

- YES >> Check the malfunctioning system. Refer to [AT-89, "SELF-DIAGNOSTIC RESULT MODE"](#) .
- NO >> GO TO 2.

#### 2. CHECK A/T FLUID LEVEL

---

Check the A/T fluid level. Refer to [AT-12, "Checking the A/T Fluid \(ATF\)"](#) .

OK or NG

- OK >> GO TO 3.
- NG >> Refill ATF.

#### 3. CHECK CONTROL CABLE

---

Check the control cable.

- Refer to [AT-217, "Checking of A/T Position"](#) .

OK or NG

- OK >> GO TO 4.
- NG >> Adjust control cable. Refer to [AT-217, "Adjustment of A/T Position"](#) .

#### 4. CHECK A/T FLUID CONDITION

---

1. Remove oil pan. Refer to [AT-228, "Control Valve With TCM and A/T Fluid Temperature Sensor 2"](#) .
2. Check A/T fluid condition. Refer to [AT-52, "Fluid Condition Check"](#) .

OK or NG

- OK >> GO TO 5.
- NG >> GO TO 8.

#### 5. DETECT MALFUNCTIONING ITEM

---

- Check the malfunction items. If any items are damaged, repair or replace damaged parts. Refer to [AT-64, "Symptom Chart"](#) (Symptom No. 15).

OK or NG

- OK >> GO TO 6.
- NG >> Repair or replace damaged parts.

#### 6. CHECK SYMPTOM

---

Check again. Refer to [AT-60, "Cruise Test - Part 3"](#) .

OK or NG

- OK >> **INSPECTION END**
- NG >> GO TO 7.



# TROUBLE DIAGNOSIS FOR SYMPTOMS

---

## 7. PERFORM TCM INSPECTION

---

1. Perform TCM input/output signals inspection. Refer to [AT-86, "TCM Input/Output Signal Reference Values"](#) .
2. If NG, recheck A/T assembly harness connector terminals for damage or loose connection with harness connector.

OK or NG

- OK >> **INSPECTION END**  
NG >> Repair or replace damaged parts.

## 8. DETECT MALFUNCTIONING ITEM

---

- Check the malfunction items. If any items are damaged, repair or replace damaged parts. Refer to [AT-64, "Symptom Chart"](#) (Symptom No. 15).

OK or NG

- OK >> GO TO 6.  
NG >> Repair or replace damaged parts.

A  
B  
AT  
D  
E  
F  
G  
H  
I  
J  
K  
L  
M

# TROUBLE DIAGNOSIS FOR SYMPTOMS

UCS0048H

---

## A/T Does Not Shift: 3rd gear → 2nd gear

### SYMPTOM:

When shifted from 3 to 2 position, does not downshift from 3rd to 2nd gears.

### DIAGNOSTIC PROCEDURE

---

#### 1. CHECK SELF-DIAGNOSIS RESULTS

Perform self-diagnosis. Refer to [AT-89, "SELF-DIAGNOSTIC RESULT MODE"](#) .

Is any malfunction detected by self-diagnostic results?

- YES >> Check the malfunctioning system. Refer to [AT-89, "SELF-DIAGNOSTIC RESULT MODE"](#) .
- NO >> GO TO 2.

---

#### 2. CHECK A/T FLUID LEVEL

Check the A/T fluid level. Refer to [AT-12, "Checking the A/T Fluid \(ATF\)"](#) .

OK or NG

- OK >> GO TO 3.
- NG >> Refill ATF.

---

#### 3. CHECK CONTROL CABLE

Check the control cable.

- Refer to [AT-217, "Checking of A/T Position"](#) .

OK or NG

- OK >> GO TO 4.
- NG >> Adjust control cable. Refer to [AT-217, "Adjustment of A/T Position"](#) .

---

#### 4. CHECK A/T FLUID CONDITION

1. Remove oil pan. Refer to [AT-228, "Control Valve With TCM and A/T Fluid Temperature Sensor 2"](#) .
2. Check A/T fluid condition. Refer to [AT-52, "Fluid Condition Check"](#) .

OK or NG

- OK >> GO TO 5.
- NG >> GO TO 8.

---

#### 5. DETECT MALFUNCTIONING ITEM

- Check the malfunction items. If any items are damaged, repair or replace damaged parts. Refer to [AT-64, "Symptom Chart"](#) (Symptom No. 16).

OK or NG

- OK >> GO TO 6.
- NG >> Repair or replace damaged parts.

---

#### 6. CHECK SYMPTOM

Check again. Refer to [AT-60, "Cruise Test - Part 3"](#) .

OK or NG

- OK >> **INSPECTION END**
- NG >> GO TO 7.

# TROUBLE DIAGNOSIS FOR SYMPTOMS

---

## 7. PERFORM TCM INSPECTION

---

1. Perform TCM input/output signals inspection. Refer to [AT-86, "TCM Input/Output Signal Reference Values"](#) .
2. If NG, recheck A/T assembly harness connector terminals for damage or loose connection with harness connector.

OK or NG

- OK >> **INSPECTION END**  
NG >> Repair or replace damaged parts.

## 8. DETECT MALFUNCTIONING ITEM

---

- Check the malfunction items. If any items are damaged, repair or replace damaged parts. Refer to [AT-64, "Symptom Chart"](#) (Symptom No. 16).

OK or NG

- OK >> GO TO 6.  
NG >> Repair or replace damaged parts.

A  
B  
AT  
D  
E  
F  
G  
H  
I  
J  
K  
L  
M

# TROUBLE DIAGNOSIS FOR SYMPTOMS

UCS0048I

## A/T Does Not Shift: 2nd gear → 1st gear

### SYMPTOM:

When shifted from 2 to 1 position, does not downshift from 2nd to 1st gears.

### DIAGNOSTIC PROCEDURE

#### 1. CHECK SELF-DIAGNOSIS RESULTS

Perform self-diagnosis. Refer to [AT-89, "SELF-DIAGNOSTIC RESULT MODE"](#) .

Is any malfunction detected by self-diagnostic results?

- YES >> Check the malfunctioning system. Refer to [AT-89, "SELF-DIAGNOSTIC RESULT MODE"](#) .  
NO >> GO TO 2.

#### 2. CHECK 1ST POSITION SWITCH CIRCUIT

##### With CONSULT-II

- Turn ignition switch "ON".
- Select "ECU INPUT SIGNALS" in "DATA MONITOR" mode for "A/T" with CONSULT-II.
- Read out "1 POSITION SW" switch moving selector lever to each position.

Monitor item	Condition	Display value
1 POSITION SW	When setting the selector lever to "1" position.	ON
	When setting selector lever to other positions.	OFF

DATA MONITOR	
MONITORING	
1 POSITION SW	OFF
OD CONT SW	ON
POWERSHIFT SW	OFF
HOLD SW	OFF
MANU MODE SW	OFF

LCIA0339E

##### Without CONSULT-II

- Turn ignition switch "ON". (Do not start engine)
- Check voltage between A/T device harness connector terminal and ground.

Item	Connector No.	Terminal No.	Condition	Data (Approx.)
1st position switch	M156	9 - Ground	When setting the selector lever to "1" position.	0V
			When setting selector lever to other positions.	Battery voltage

OK or NG

- OK >> GO TO 3.  
NG >> Repair or replace damaged parts.

#### 3. CHECK A/T FLUID LEVEL

Check the A/T fluid level. Refer to [AT-12, "Checking the A/T Fluid \(ATF\)"](#) .

OK or NG

- OK >> GO TO 4.  
NG >> Refill ATF.

# TROUBLE DIAGNOSIS FOR SYMPTOMS

---

## 4. CHECK CONTROL CABLE

---

Check the control cable.

- Refer to [AT-217, "Checking of A/T Position"](#) .

OK or NG

OK >> GO TO 5.

NG >> Adjust control cable. Refer to [AT-217, "Adjustment of A/T Position"](#) .

---

## 5. CHECK A/T FLUID CONDITION

---

1. Remove oil pan. Refer to [AT-228, "Control Valve With TCM and A/T Fluid Temperature Sensor 2"](#) .
2. Check A/T fluid condition. Refer to [AT-52, "Fluid Condition Check"](#) .

OK or NG

OK >> GO TO 6.

NG >> GO TO 9.

---

## 6. DETECT MALFUNCTIONING ITEM

---

- Check the malfunction items. If any items are damaged, repair or replace damaged parts. Refer to [AT-64, "Symptom Chart"](#) (Symptom No. 17).

OK or NG

OK >> GO TO 7.

NG >> Repair or replace damaged parts.

---

## 7. CHECK SYMPTOM

---

Check again. Refer to [AT-60, "Cruise Test - Part 3"](#) .

OK or NG

OK >> **INSPECTION END**

NG >> GO TO 8.

---

## 8. PERFORM TCM INSPECTION

---

1. Perform TCM input/output signals inspection. Refer to [AT-86, "TCM Input/Output Signal Reference Values"](#) .
2. If NG, recheck A/T assembly harness connector terminals for damage or loose connection with harness connector.

OK or NG

OK >> **INSPECTION END**

NG >> Repair or replace damaged parts.

---

## 9. DETECT MALFUNCTIONING ITEM

---

- Check the malfunction items. If any items are damaged, repair or replace damaged parts. Refer to [AT-64, "Symptom Chart"](#) (Symptom No. 17).

OK or NG

OK >> GO TO 7.

NG >> Repair or replace damaged parts.

# TROUBLE DIAGNOSIS FOR SYMPTOMS

UCS0048J

## Vehicle Does Not Decelerate By Engine Brake

### SYMPTOM:

No engine brake is applied when the gear is shifted from the 22 to 11 .

### DIAGNOSTIC PROCEDURE

#### 1. CHECK SELF-DIAGNOSIS RESULTS

Perform self-diagnosis.

Is any malfunction detected by self-diagnostic results?

- YES >> Check the malfunctioning system. Refer to [AT-89, "SELF-DIAGNOSTIC RESULT MODE"](#) .  
 NO >> GO TO 2.

#### 2. CHECK 1ST POSITION SWITCH CIRCUIT

##### ① With CONSULT-II

- Turn ignition switch "ON".
- Select "ECU INPUT SIGNALS" in "DATA MONITOR" mode for "A/T" with CONSULT-II.
- Read out "1 POSITION SW" moving switch selector lever to each position.

Monitor item	Condition	Display value
1 POSITION SW	When setting the selector lever to "1" position.	ON
	When setting selector lever to other positions.	OFF

DATA MONITOR	
MONITORING	
1 POSITION SW	OFF
OD CONT SW	ON
POWERSHIFT SW	OFF
HOLD SW	OFF
MANU MODE SW	OFF

LCIA0339E

##### ② Without CONSULT-II

- Turn ignition switch "ON". (Do not start engine)
- Check voltage between A/T device harness connector terminal and ground.

Item	Connector No.	Terminal No.	Condition	Data (Approx.)
1st position switch	M156	9 - Ground	When setting the selector lever to "1" position.	0V
			When setting selector lever to other positions.	Battery voltage

OK or NG

- OK >> GO TO 3.  
 NG >> Repair or replace damaged parts.

#### 3. CHECK A/T FLUID LEVEL

Check the A/T fluid level. Refer to [AT-12, "Checking the A/T Fluid \(ATF\)"](#) .

OK or NG

- OK >> GO TO 4.  
 NG >> Refill ATF.

# TROUBLE DIAGNOSIS FOR SYMPTOMS

---

## 4. CHECK CONTROL CABLE

---

Check the control cable.

- Refer to [AT-217, "Checking of A/T Position"](#) .

OK or NG

OK >> GO TO 5.

NG >> Adjust control cable. Refer to [AT-217, "Adjustment of A/T Position"](#) .

---

## 5. CHECK A/T FLUID CONDITION

---

1. Remove oil pan. Refer to [AT-228, "Control Valve With TCM and A/T Fluid Temperature Sensor 2"](#) .
2. Check A/T fluid condition. Refer to [AT-52, "Fluid Condition Check"](#) .

OK or NG

OK >> GO TO 6.

NG >> GO TO 9.

---

## 6. DETECT MALFUNCTIONING ITEM

---

- Check the malfunction items. If any items are damaged, repair or replace damaged parts. Refer to [AT-64, "Symptom Chart"](#) (Symptom No. 53).

OK or NG

OK >> GO TO 7.

NG >> Repair or replace damaged parts.

---

## 7. CHECK SYMPTOM

---

Check again. Refer to [AT-60, "Cruise Test - Part 3"](#) .

OK or NG

OK >> **INSPECTION END**

NG >> GO TO 8.

---

## 8. PERFORM TCM INSPECTION

---

1. Perform TCM input/output signals inspection. Refer to [AT-86, "TCM Input/Output Signal Reference Values"](#) .
2. If NG, recheck A/T assembly harness connector terminals for damage or loose connection with harness connector.

OK or NG

OK >> **INSPECTION END**

NG >> Repair or replace damaged parts.

---

## 9. DETECT MALFUNCTIONING ITEM

---

- Check the malfunction items. If any items are damaged, repair or replace damaged parts. Refer to [AT-64, "Symptom Chart"](#) (Symptom No. 53).

OK or NG

OK >> GO TO 7.

NG >> Repair or replace damaged parts.

# SHIFT CONTROL SYSTEM

## SHIFT CONTROL SYSTEM

PF0:34901

### Control Device Removal and Installation

UCS0048K

SEC. 349

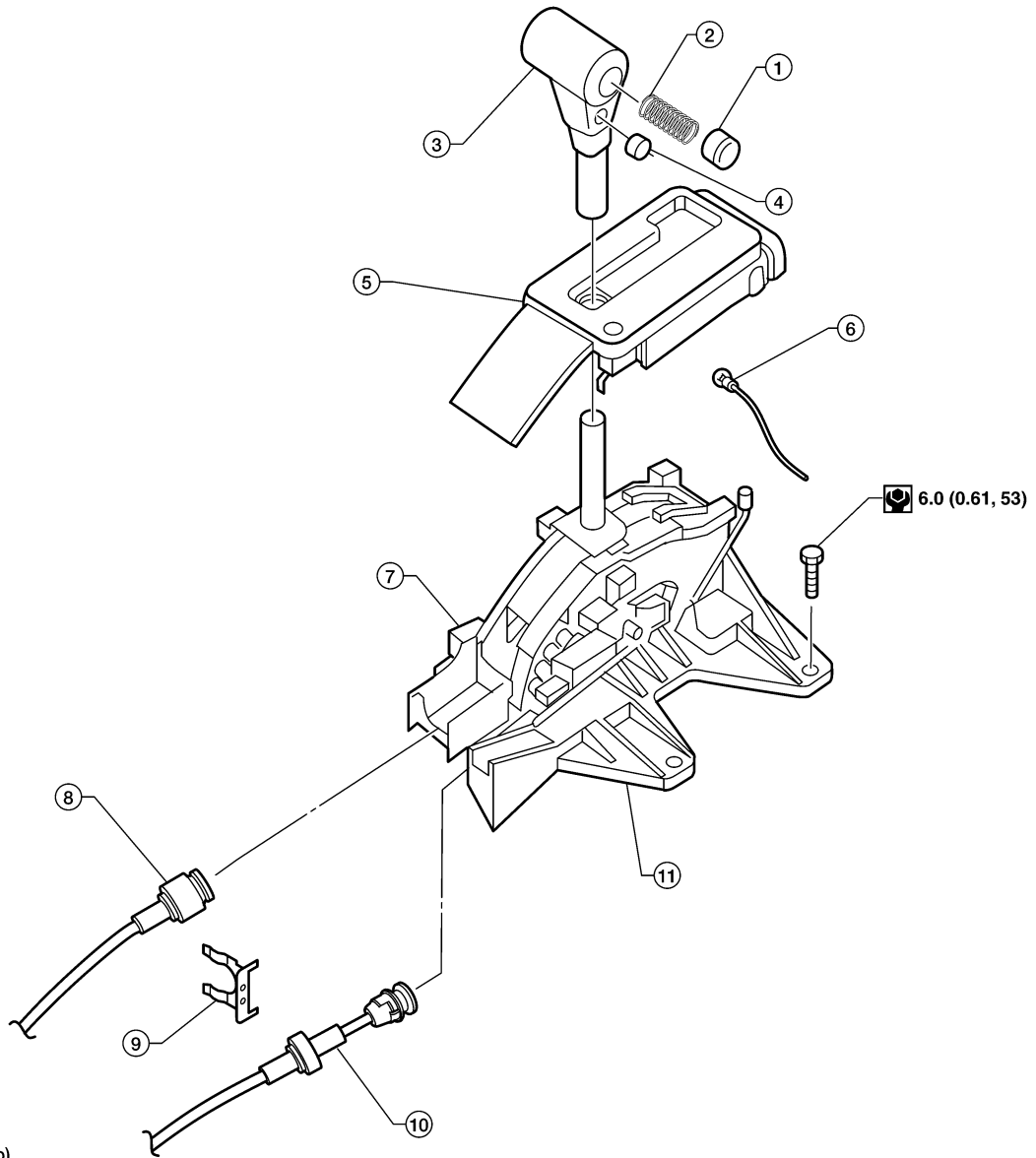

 : N·m (kg-m, in-lb)

WCIA0503E

- |                             |                                 |                   |
|-----------------------------|---------------------------------|-------------------|
| 1. Selector button          | 2. Selector spring              | 3. Selector lever |
| 4. Overdrive control switch | 5. Position indicator           | 6. Position lamp  |
| 7. A/T device connector     | 8. A/T selector control cable   | 9. Lock plate     |
| 10. A/T key interlock cable | 11. A/T control device assembly |                   |



# SHIFT CONTROL SYSTEM

## REMOVAL

1. Remove the A/T finisher. Refer to [IP-10, "INSTRUMENT PANEL ASSEMBLY"](#) .
2. Disconnect the following from the A/T control device assembly.
  - A/T selector control cable
  - A/T key interlock cable
  - A/T device connector
3. Remove the A/T control device assembly.

## INSTALLATION

Installation is in reverse order of removal.

## Adjustment of A/T Position

1. Loosen nut of control cable.
2. Place the manual lever and selector lever in "P" position.
3. Push the control cable in the direction shown with a force of 9.8 N (1kg, 2.2 lb), release it. This is in the natural state, tighten control cable nut to specifications.

**Control cable nut : 14.5 N-m (1.5 kg-m, 11 ft-lb)**

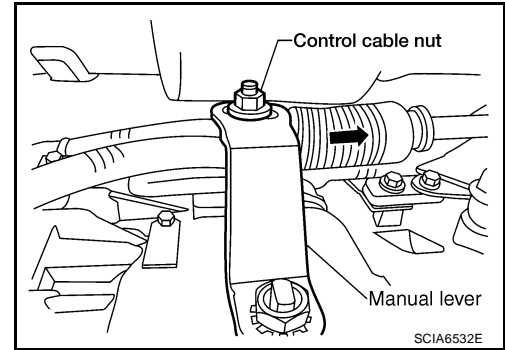

## Checking of A/T Position

With the selector lever in the "P" position, turn the ignition switch to the ON position with the engine OFF. Confirm that the following conditions apply.

- The selector lever can be shifted from the "P" position when the brake pedal is depressed.
- The selector lever stops at each position with the feel of engagement when it is moved through all the positions.
- There is no excessive effort, sticking, noise or rattle.
- The actual position of the selector lever matches the position shown by the shift position indicator and the A/T body.
- The back-up lamps illuminate only when the selector lever is placed in the "R" position.
- The back-up lamps do not illuminate when the selector lever is pushed against the "R" position when in the "P" or "N" position.
- The engine can only be started with the selector lever in the "P" and "N" positions.
- The A/T is locked completely when in the "P" position.

# A/T SHIFT LOCK SYSTEM

## A/T SHIFT LOCK SYSTEM

PF:34950

### Description

UCS0048N

- The mechanical key interlock mechanism also operates as a shift lock:  
With the ignition switch turned to ON, the selector lever cannot be shifted from "P" (parking) to any other position unless the brake pedal is depressed.  
With the key removed, the selector lever cannot be shifted from "P" to any other position.  
The key cannot be removed unless the selector lever is placed in "P" position.
- The shift lock and key interlock mechanisms are controlled by the ON-OFF operation of the shift lock solenoid and by the operation of the rotator and slider located inside the key cylinder, respectively.

### Shift Lock System Electrical Parts Location

UCS0048O

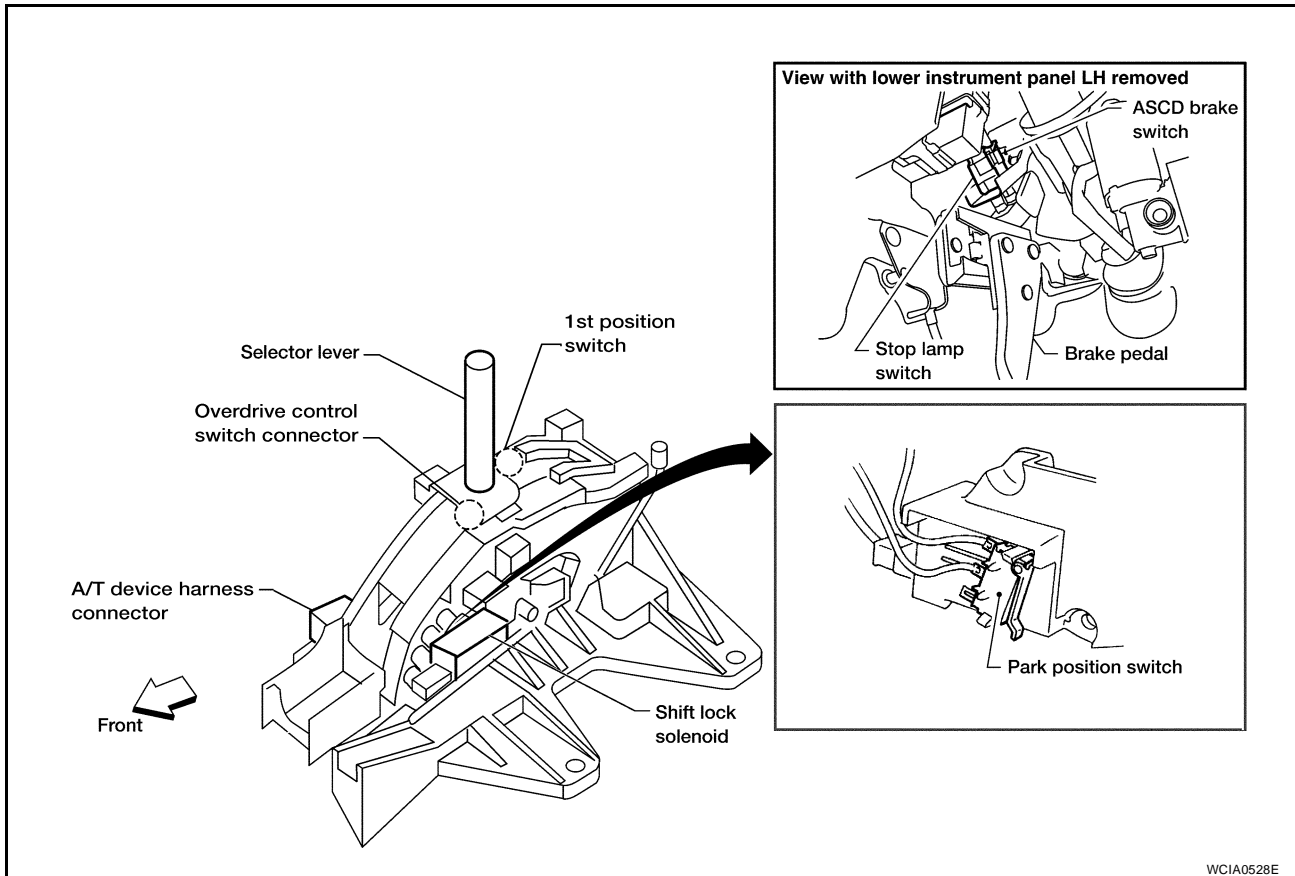

# A/T SHIFT LOCK SYSTEM

## Wiring Diagram — A/T — SHIFT

UCS0048P

AT-SHIFT-01

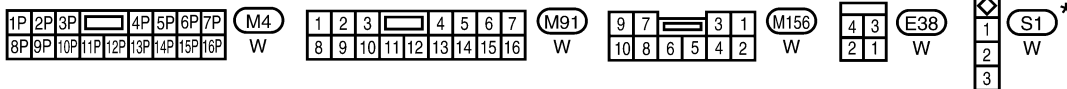
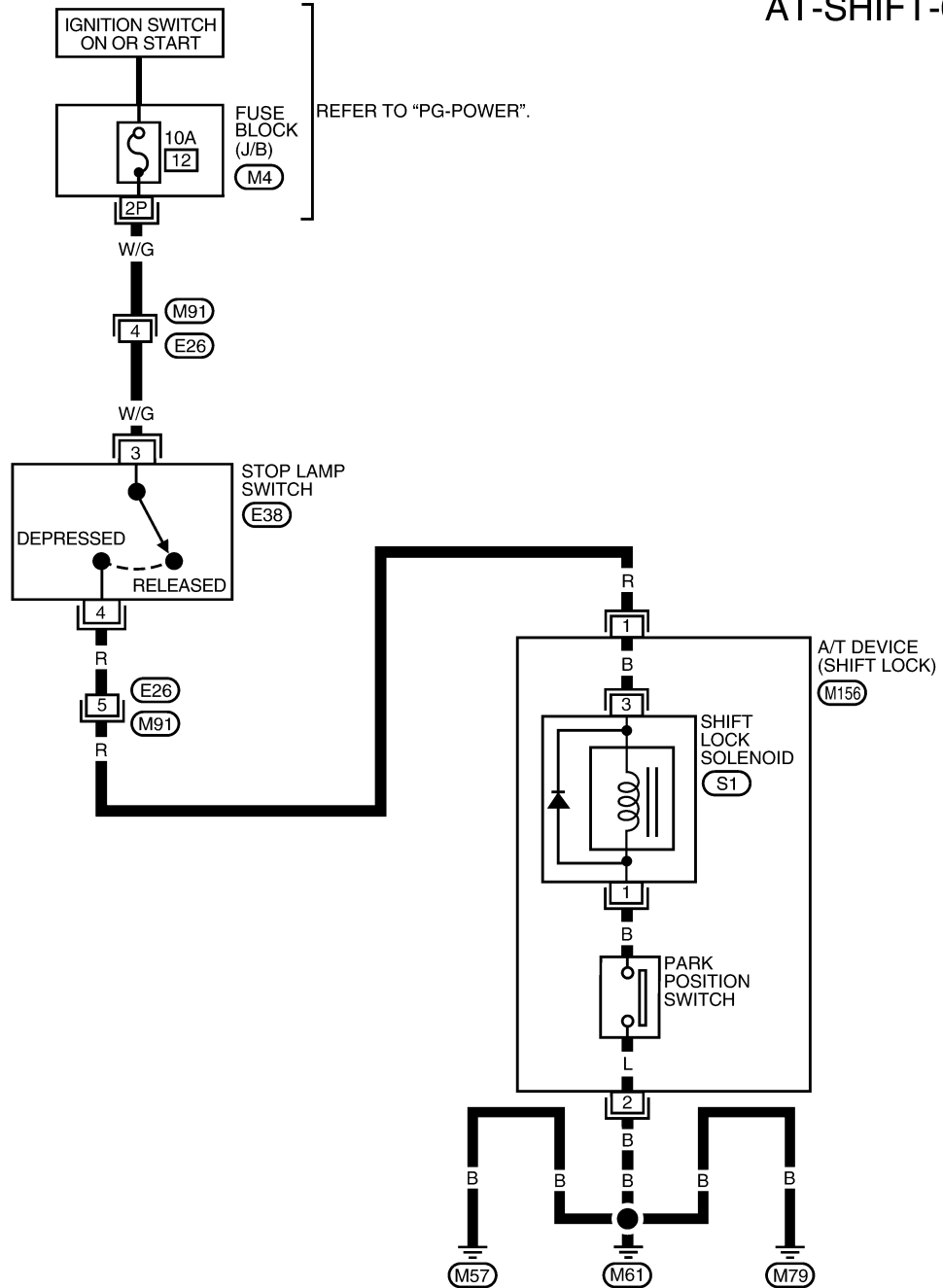

\* : THIS CONNECTOR IS NOT SHOWN IN "HARNESS LAYOUT" OF PG SECTION.

BCWA0572E

# A/T SHIFT LOCK SYSTEM

UCS0048Q

## Diagnostic Procedure

### SYMPTOM 1:

- Selector lever cannot be moved from “P” position with key in ON position and brake pedal applied.
- Selector lever can be moved from “P” position with key in ON position and brake pedal released.
- Selector lever can be moved from “P” position when key is removed from key cylinder.

### SYMPTOM 2:

- Ignition key cannot be removed when selector lever is set to “P” position.
- Ignition key can be removed when selector lever is set to any position except “P”.

## 1. CHECK KEY INTERLOCK CABLE

Check key interlock cable for damage.

### OK or NG

OK >> GO TO 2.

NG >> Repair key interlock cable. Refer to [AT-223, "KEY INTERLOCK CABLE"](#) .

## 2. CHECK SELECTOR LEVER POSITION

Check selector lever position for damage. Refer to [AT-217, "Checking of A/T Position"](#) .

### OK or NG

OK >> GO TO 3.

NG >> Check selector lever. Refer to [AT-217, "Adjustment of A/T Position"](#) .

## 3. CHECK INPUT SIGNAL A/T DEVICE

1. Turn ignition switch “ON”.
2. Check voltage between A/T device harness connector M156 terminal 1 and ground.

### Voltage

**Depressed brake pedal :Battery voltage**

**Released brake pedal :Approx. 0V**

### OK or NG

OK >> GO TO 5.

NG >> GO TO 4.

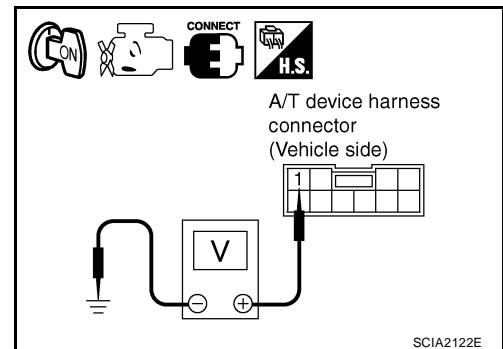

# A/T SHIFT LOCK SYSTEM

## 4. DETECT MALFUNCTIONING ITEM

Check the following.

1. Harness for short or open between ignition switch and stop lamp switch harness connector E38 terminal 3.
2. Harness for short or open between stop lamp switch harness connector E38 terminal 4 and A/T device harness connector M156 terminal 1.
3. 10A fuse. [No.12, located in the fuse block (J/B)]
4. Stop lamp switch.
  - Check continuity between stop lamp switch terminals 3 and 4.

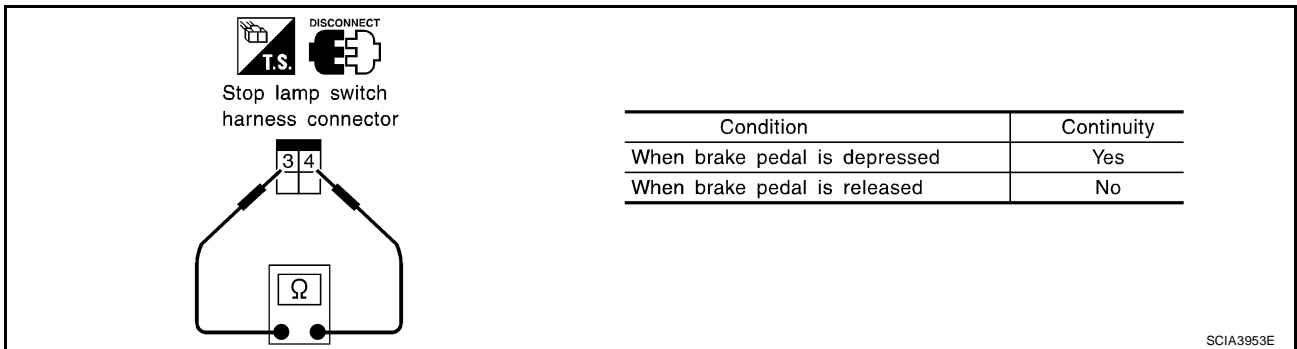

Check stop lamp switch after adjusting brake pedal — refer to [BR-6, "BRAKE PEDAL"](#).

OK or NG

- OK >> GO TO 5.
- NG >> Repair or replace damaged parts.

## 5. CHECK GROUND CIRCUIT

1. Turn ignition switch "OFF".
2. Disconnect A/T device harness connector.
3. Check continuity between A/T device harness connector M156 terminal 2 and ground.

**Continuity should exist.**

If OK, check harness for short to ground and short to power.

OK or NG

- OK >> GO TO 6.
- NG >> Repair open circuit or short to ground or short to power in harness or connectors.

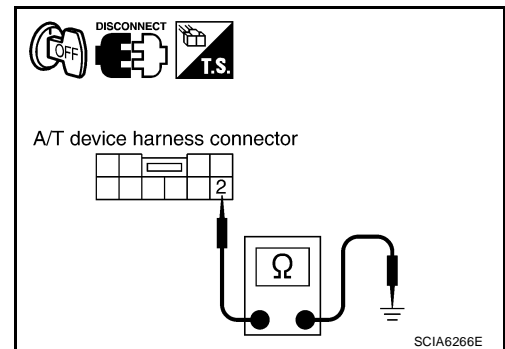

# A/T SHIFT LOCK SYSTEM

## 6. CHECK PARK POSITION SWITCH AND SHIFT LOCK SOLENOID CIRCUIT

Check continuity between A/T device terminals 1 and 2.

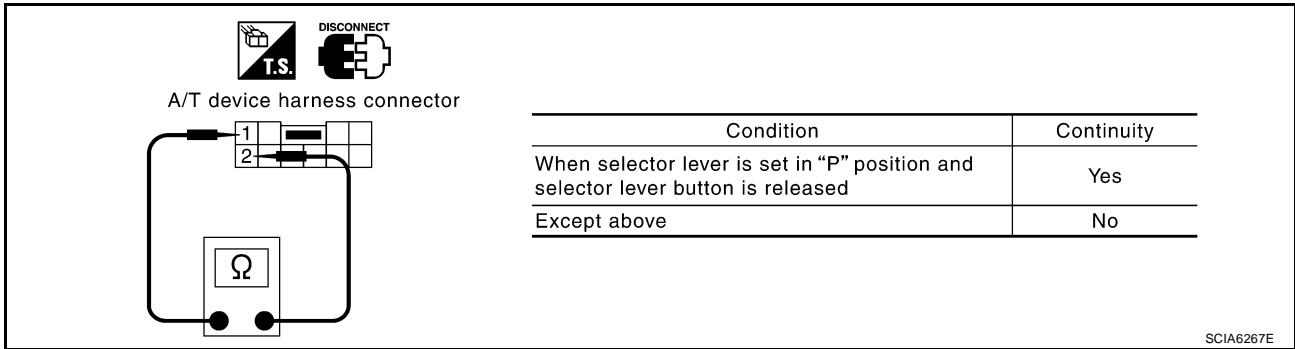

Condition	Continuity
When selector lever is set in "P" position and selector lever button is released	Yes
Except above	No

SCIA6267E

OK or NG

OK >> **INSPECTION END**

NG >> ● Replace park position switch or shift lock solenoid.

● Repair open circuit or short to ground or short to power in harness or connectors.

# KEY INTERLOCK CABLE

PFP:34908

UCS0048R

## KEY INTERLOCK CABLE

### Components

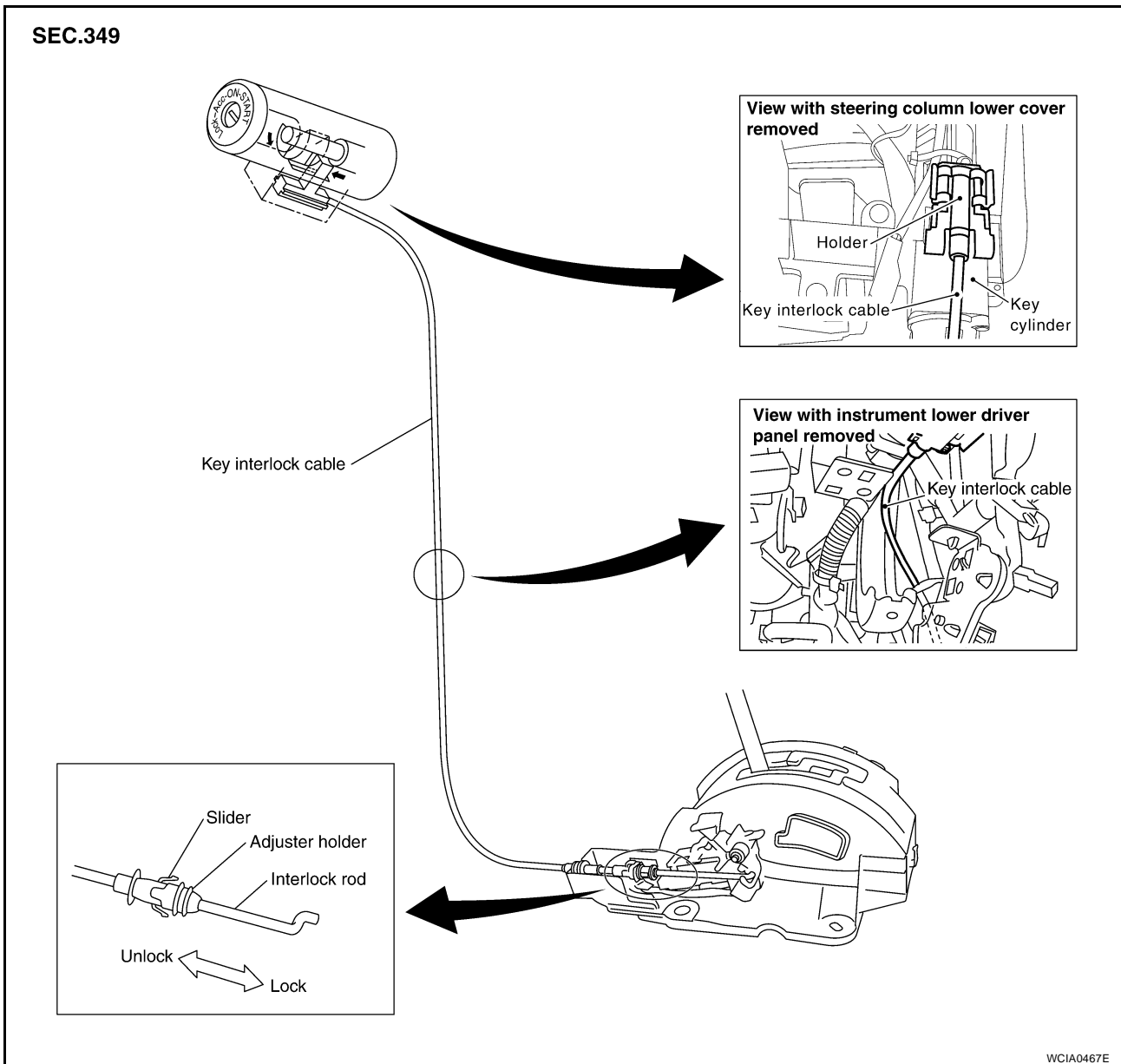

#### CAUTION:

- Install key interlock cable in such a way that it will not be damaged by sharp bends, twists or interference with adjacent parts.
- After installing key interlock cable to control device, make sure that casing cap and bracket are firmly secured in their positions. If casing cap can be removed with an external load of less than 39 N (4.0 kg, 8.8 lb), replace key interlock cable with new one.

A  
B  
AT  
D  
E  
F  
G  
H  
I  
J  
K  
L  
M

# KEY INTERLOCK CABLE

UCS0048S

## Removal and Installation

### REMOVAL

1. Unlock slider by squeezing lock tabs on slider from adjuster holder.
2. Remove casing cap from bracket of control device assembly and remove interlock rod from adjuster holder.

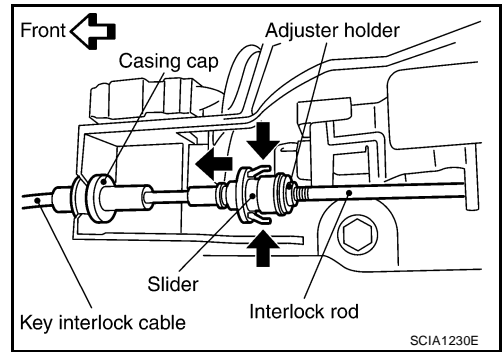

3. Remove holder from key cylinder and remove key interlock cable.

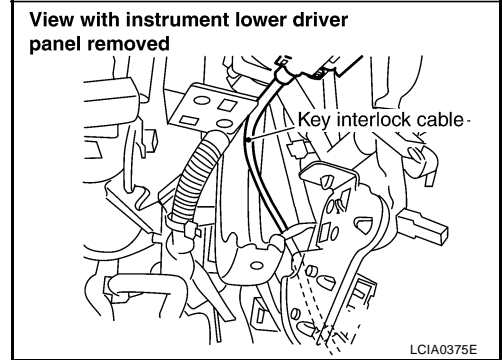
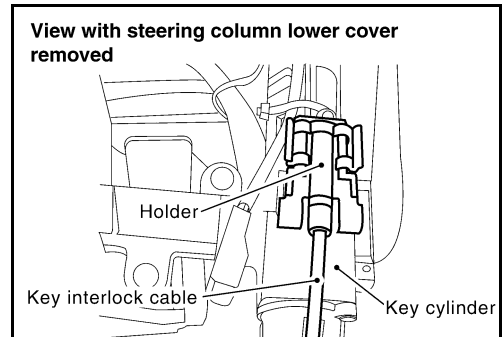

LCIA0375E



# KEY INTERLOCK CABLE

## INSTALLATION

1. Set key interlock cable to key cylinder and install holder.
2. Turn ignition key to lock position.
3. Set selector lever to "P" position.

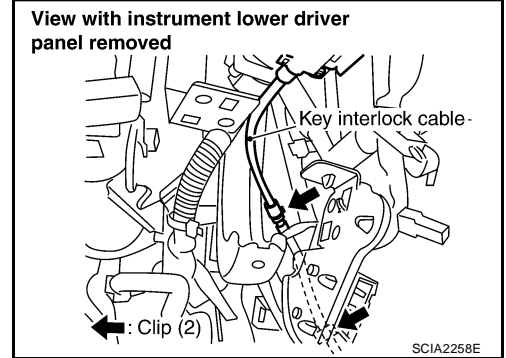
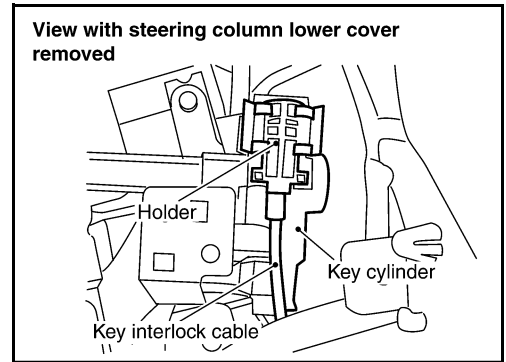

4. Insert interlock rod into adjuster holder.
5. Install casing cap to bracket.
6. Move slider in order to secure adjuster holder to interlock rod.

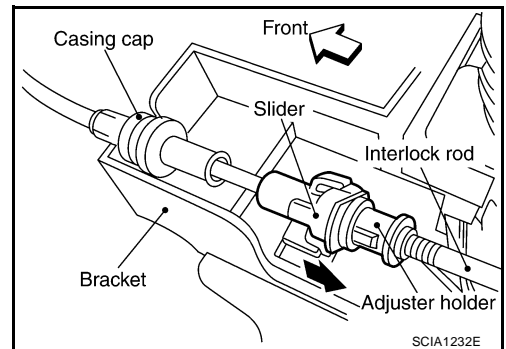

A  
B  
AT  
D  
E  
F  
G  
H  
I  
J  
K  
L  
M

## ON-VEHICLE SERVICE

PF0:0000

### Oil Pan REMOVAL AND INSTALLATION

UCS0048T

#### Removal

1. Drain A/T fluid. Refer to [AT-12, "A/T FLUID"](#).
2. Remove oil pan and gasket.

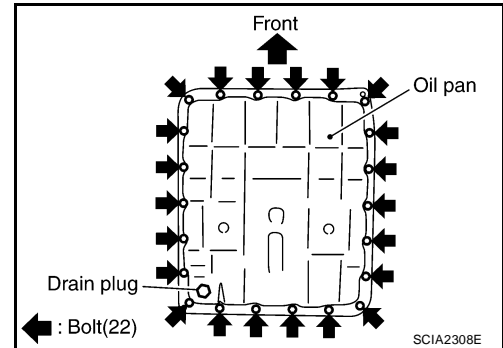

3. Check for foreign materials in oil pan to help determine cause of malfunction. If the A/T fluid is very dark, smells burned, or contains foreign particles, the friction material (clutches, band) may need replacement. A tacky film that will not wipe clean indicates varnish build up. Varnish can cause valves, servo, and clutches to stick and can inhibit pump pressure.

**CAUTION:**

If friction material is detected, flush the transmission cooler after repair. Refer to [AT-15, "A/T Fluid Cooler Cleaning"](#).

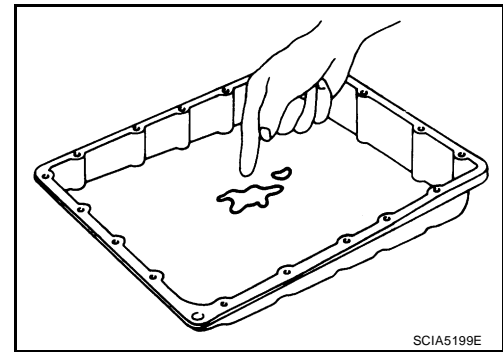

4. Remove magnets from oil pan.

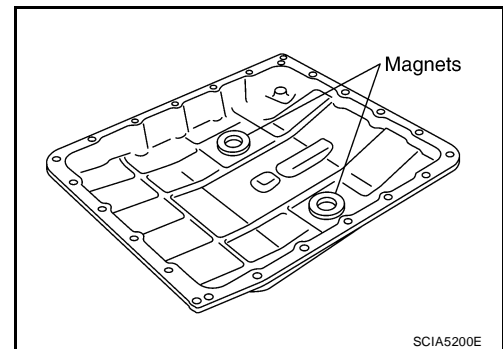

#### Installation

1. Install the oil pan magnets as shown.

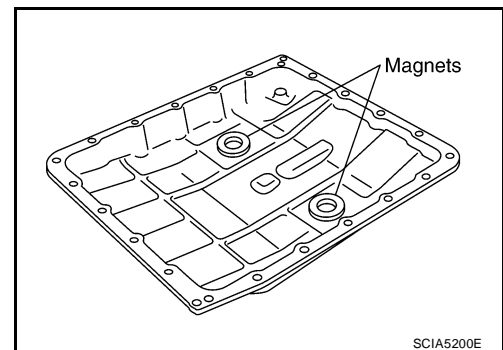

## ON-VEHICLE SERVICE

2. Install the oil pan and new oil pan gasket.

**CAUTION:**

- Be sure the oil drain plug is located to the rear of the transmission assembly.
- Before installing oil pan bolts, remove any traces of old sealant from the sealing surfaces and threaded holes.
- Do not reuse old gasket, replace with a new one.
- Always replace the oil pan bolts as they are self-sealing.
- Partially install the oil pan bolts in a criss-cross pattern to prevent dislocation of the gasket.

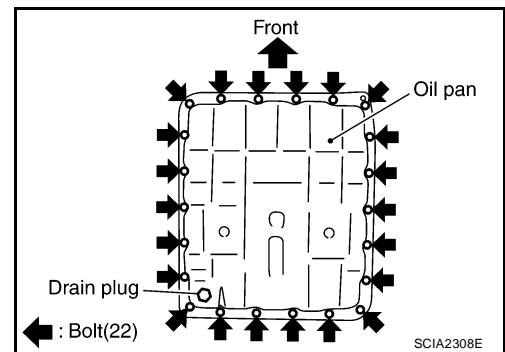

3. Tighten oil pan bolts in numerical order as shown.

**Oil pan bolts : 7.9 N-m (0.81 kg-m, 70 in-lb)**

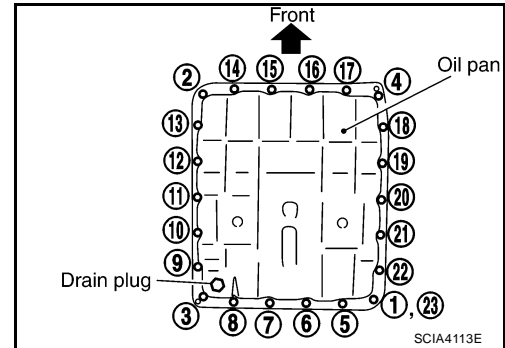

4. Install drain plug to oil pan.

**CAUTION:**

**Do not reuse drain plug gasket.**

**Drain plug : 34 N-m (3.5 kg-m, 25 ft-lb)**

5. Refill the transmission assembly with fluid. Refer to [AT-12, "A/T FLUID"](#) .

A  
B  
AT

D  
E  
F  
G

H  
I

J

K

L

M

# ON-VEHICLE SERVICE

## Control Valve With TCM and A/T Fluid Temperature Sensor 2 COMPONENTS

UCS0048U

SEC.313 · 314 · 315 · 316 · 317 · 319

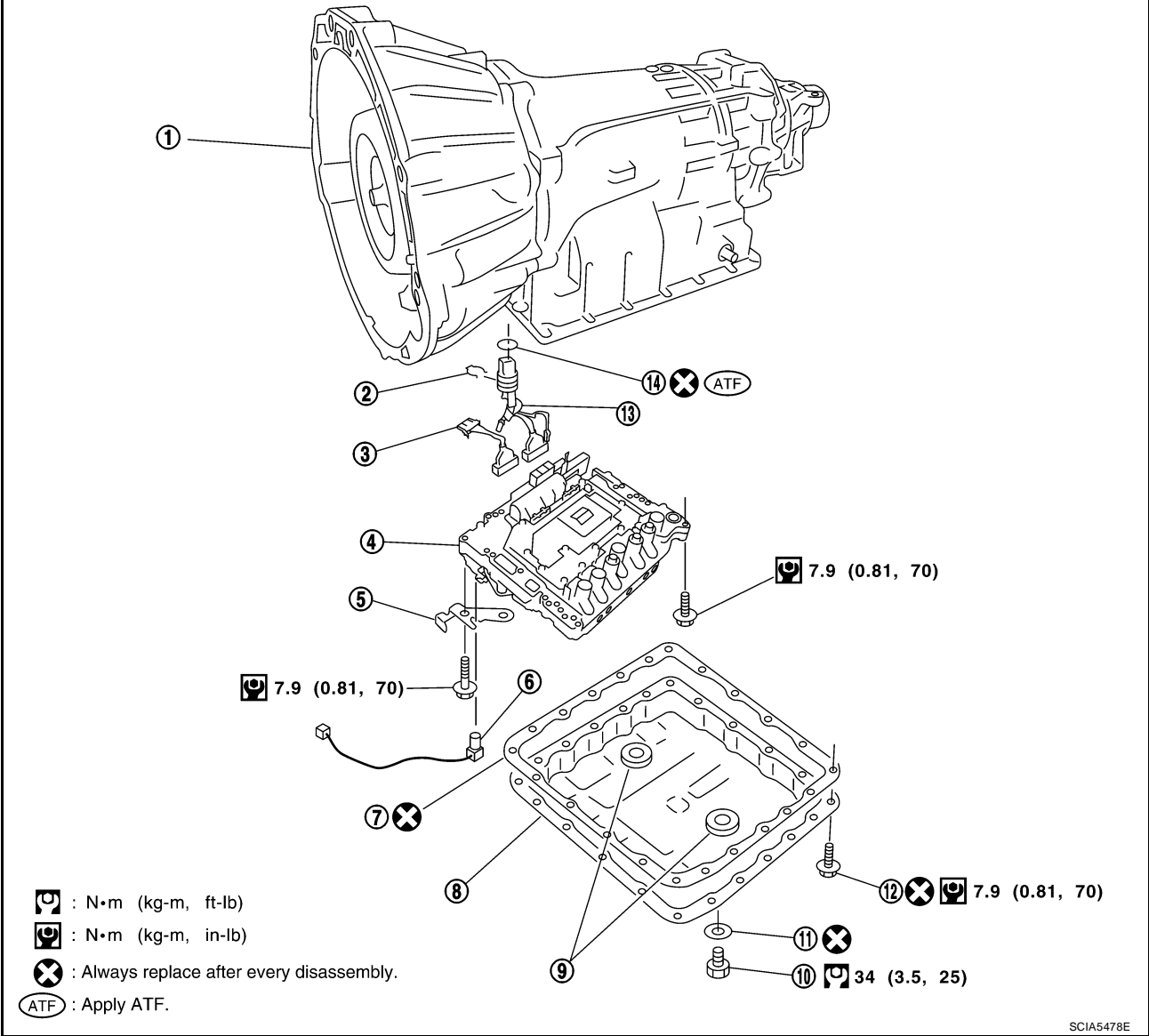

SCIA5478E

- |                            |                       |                                   |
|----------------------------|-----------------------|-----------------------------------|
| 1. Transmission            | 2. Snap ring          | 3. Sub-harness                    |
| 4. Control valve with TCM  | 5. Bracket            | 6. A/T fluid temperature sensor 2 |
| 7. Oil pan gasket          | 8. Oil pan            | 9. Magnet                         |
| 10. Drain plug             | 11. Drain plug gasket | 12. Oil pan bolt                  |
| 13. Terminal cord assembly | 14. O-ring            |                                   |

# ON-VEHICLE SERVICE

## CONTROL VALVE WITH TCM REMOVAL AND INSTALLATION

### Removal

1. Disconnect negative battery terminal.
2. Drain ATF through drain plug.
3. Disconnect A/T assembly harness connector.
4. Remove snap ring from A/T assembly harness connector.

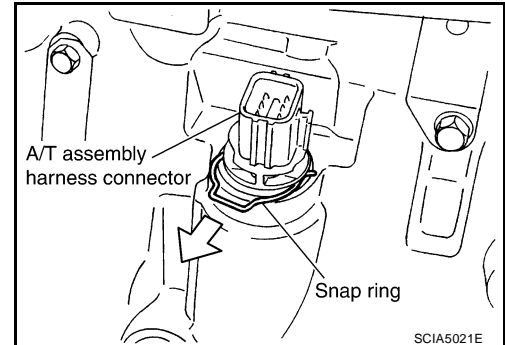

5. Push A/T assembly harness connector.

**CAUTION:**  
Do not damage connector.

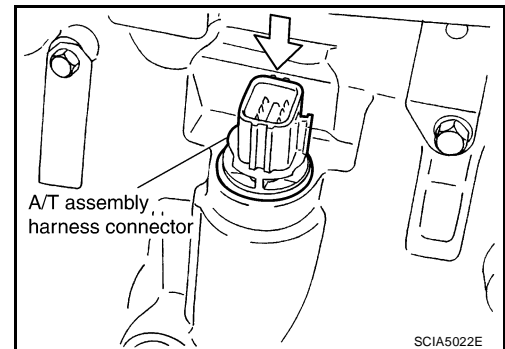

6. Remove oil pan and oil pan gasket. Refer to [AT-226, "Removal"](#).
7. Straighten terminal clip to free terminal cord assembly A/T fluid temperature sensor 2 harness.
8. Disconnect A/T fluid temperature sensor 2 connector.

**CAUTION:**  
Do not damage connector.

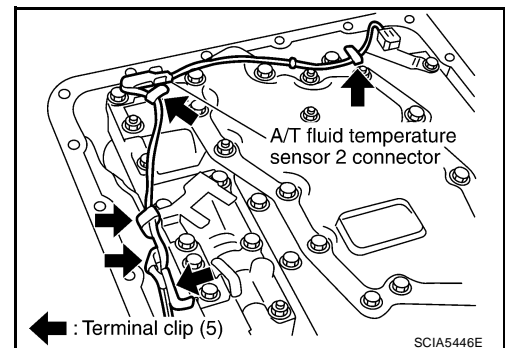

9. Straighten terminal clip to free revolution sensor harness.
10. Disconnect revolution sensor connector.

**CAUTION:**  
Do not damage connector.

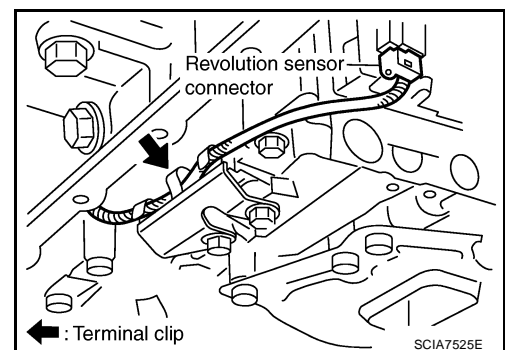

A  
B  
AT  
D  
E  
F  
G  
H  
I  
J  
K  
L  
M

# ON-VEHICLE SERVICE

11. Remove bolts A, B and C from control valve with TCM.

Bolt symbol	Length mm (in)	Number of bolts
A	42 (1.65)	5
B	55 (2.17)	6
C	40 (1.57)	1

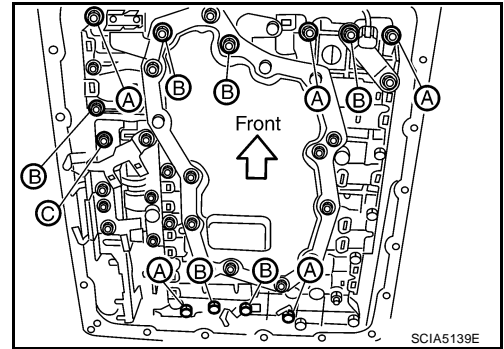

12. Remove control valve with TCM from transmission case.

**CAUTION:**

When removing, be careful with the manual valve notch and manual plate height. Remove it vertically.

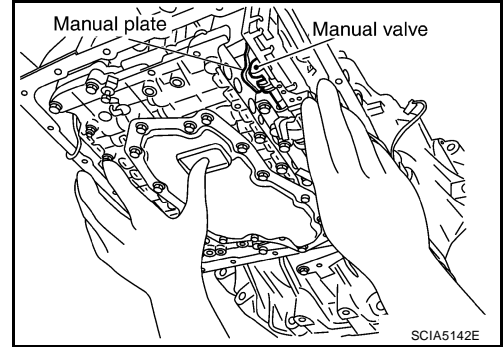

13. Remove A/T fluid temperature sensor 2 with bracket from control valve with TCM.

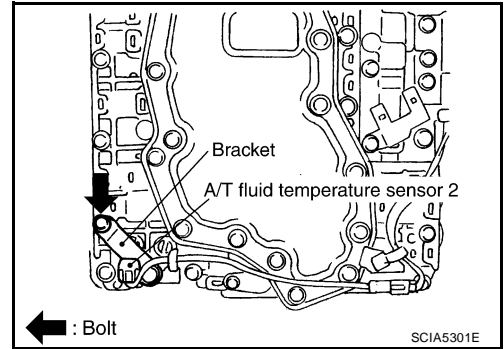

14. Remove bracket from A/T fluid temperature sensor 2.

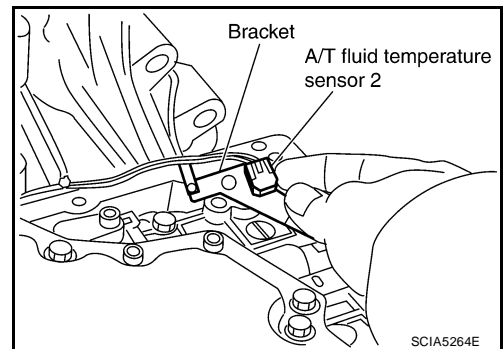

15. Remove O-ring from A/T assembly harness connector.

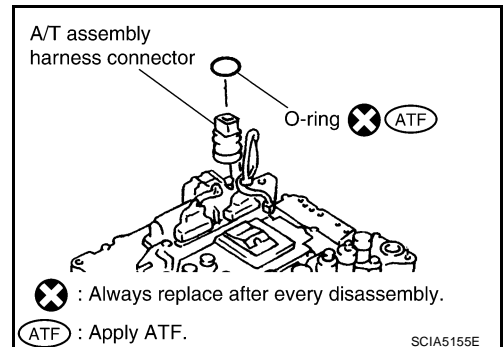

## ON-VEHICLE SERVICE

16. Disconnect TCM connectors.

**CAUTION:**  
Do not damage connectors.

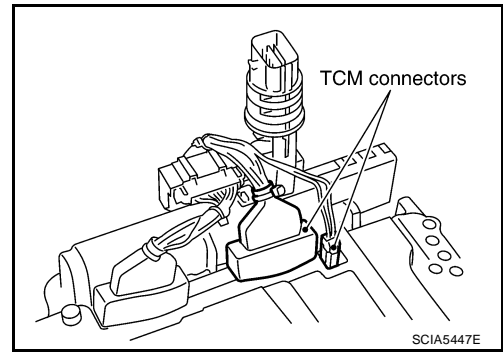

17. Remove A/T assembly harness connector from control valve with TCM using suitable tool.

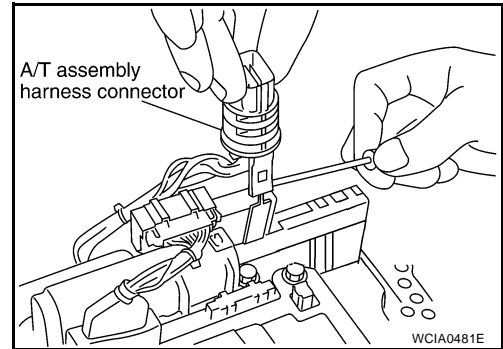

18. Disconnect TCM connector and park/neutral position switch connector.

**CAUTION:**  
Do not damage connectors.

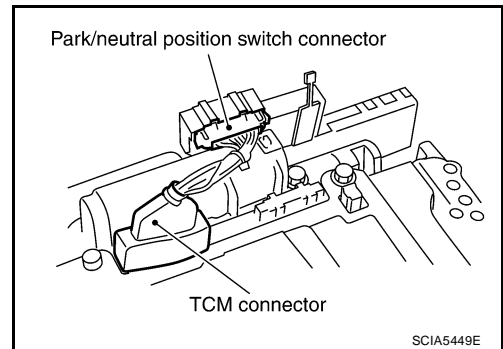

A  
B  
AT  
D  
E  
F  
G  
H  
I  
J  
K  
L  
M

# ON-VEHICLE SERVICE

## Installation

### CAUTION:

After completing installation, check A/T fluid leakage and fluid level. Refer to [AT-12, "A/T FLUID"](#) .

1. Connect TCM connector and park/neutral position switch connector.

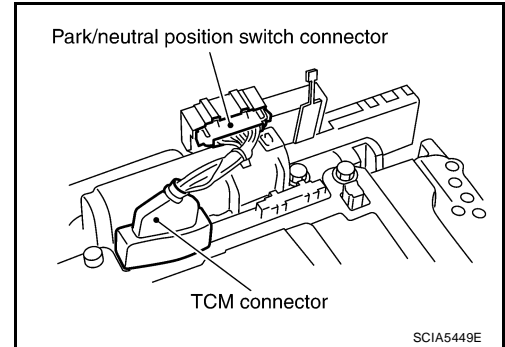

2. Install A/T assembly harness connector to control valve with TCM.

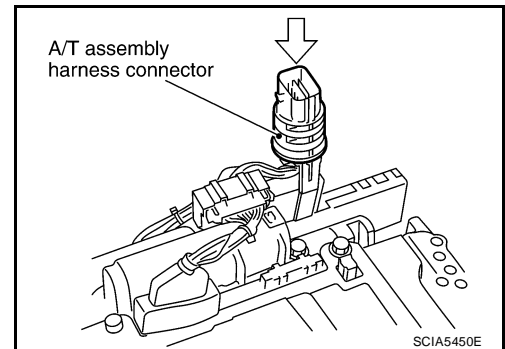

3. Connect TCM connector.

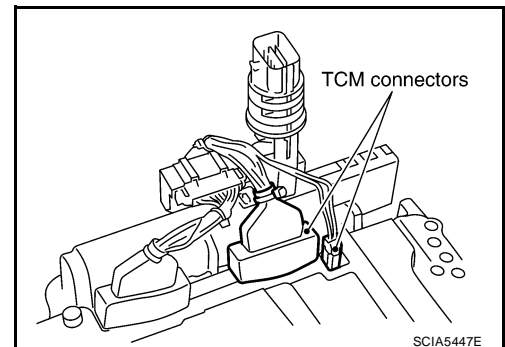

4. Install new O-ring in A/T assembly harness connector.

### CAUTION:

- Do not reuse O-ring.
- Apply ATF to O-ring.

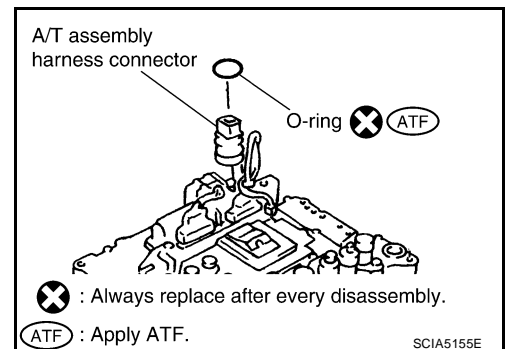



## ON-VEHICLE SERVICE

5. Install A/T fluid temperature sensor 2 to bracket.

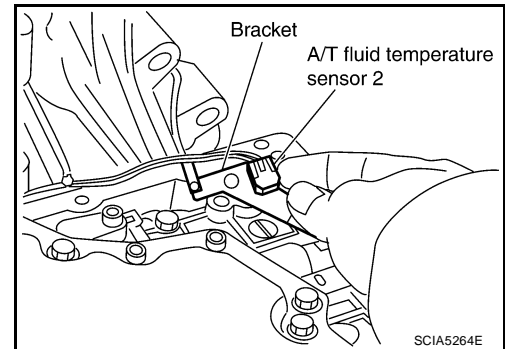

6. Install A/T fluid temperature sensor 2 (with bracket) in control valve with TCM. Tighten A/T fluid temperature sensor 2 bolt to the specified torque. Refer to [AT-228, "COMPONENTS"](#).

**CAUTION:**

**Adjust bolt hole of bracket to bolt hole of control valve with TCM.**

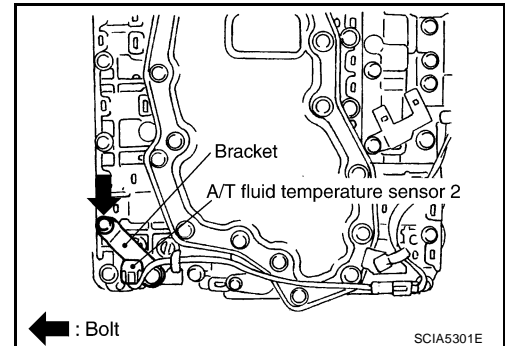

7. Install control valve with TCM in transmission case.

**CAUTION:**

- Make sure that turbine revolution sensor is securely installed into turbine revolution sensor hole.
- Hang down revolution sensor harness toward outside so as not to disturb installation of control valve with TCM.
- Adjust A/T assembly harness connector of control valve with TCM to terminal hole of transmission case.

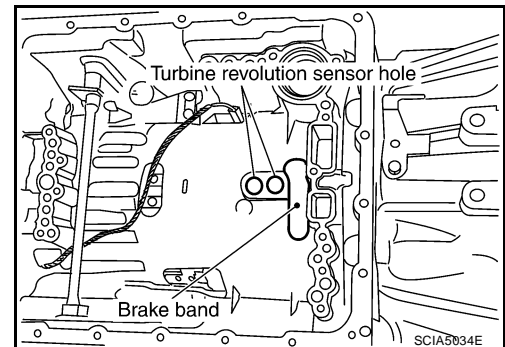

- Assemble it so that manual valve cutout is engaged with manual plate projection.

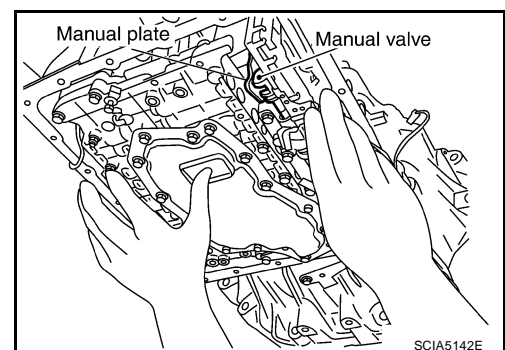

## ON-VEHICLE SERVICE

8. Install bolts A, B and C in control valve with TCM.

Bolt symbol	Length mm (in)	Number of bolts
A	42 (1.65)	5
B	55 (2.17)	6
C	40 (1.57)	1

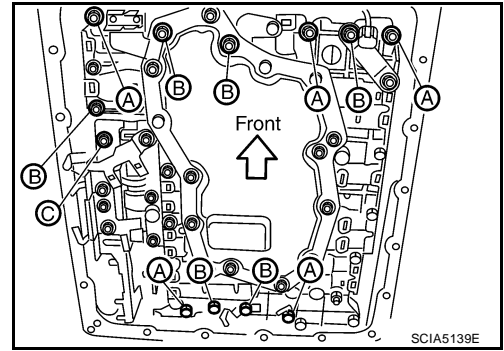

9. Tighten bolts 1, 2 and 3 temporarily to prevent dislocation. After that tighten them in order (1 → 2 → 3), and then tighten other bolts.
10. Tighten control valve with TCM bolts to the specified torque. Refer to [AT-228, "COMPONENTS"](#).

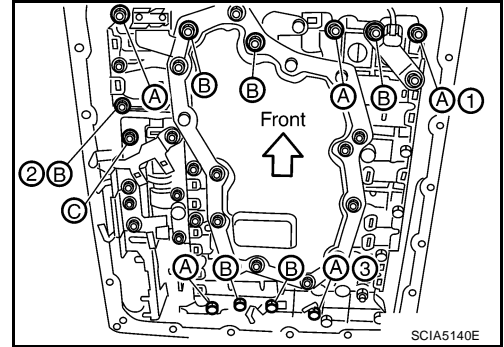

11. Connect A/T fluid temperature sensor 2 connector.
12. Securely fasten terminal cord assembly and A/T fluid temperature sensor 2 harness with terminal clips.

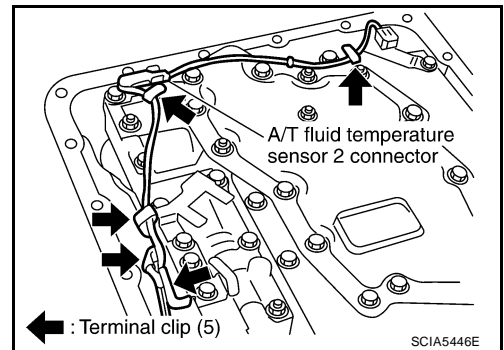

13. Connect revolution sensor connector.
14. Securely fasten revolution sensor harness with terminal clip.

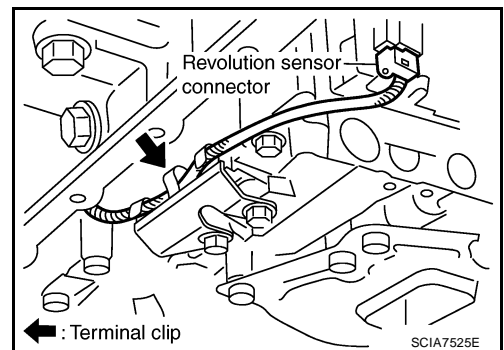

15. Install oil pan to transmission case. Refer to [AT-226, "Installation"](#).

# ON-VEHICLE SERVICE

16. Pull up A/T assembly harness connector.

**CAUTION:**  
Do not damage connector.

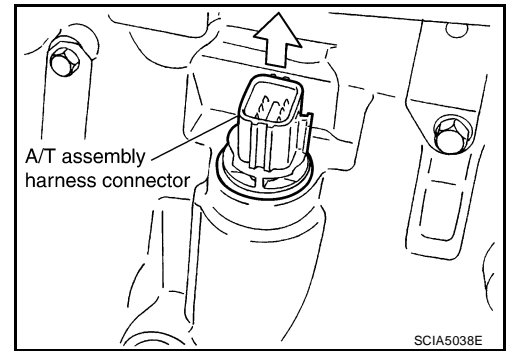

17. Install snap ring to A/T assembly harness connector.
18. Connect A/T assembly harness connector.
19. Pour ATF into transmission assembly. Refer to [AT-12, "A/T FLUID"](#).
20. Connect the negative battery terminal.

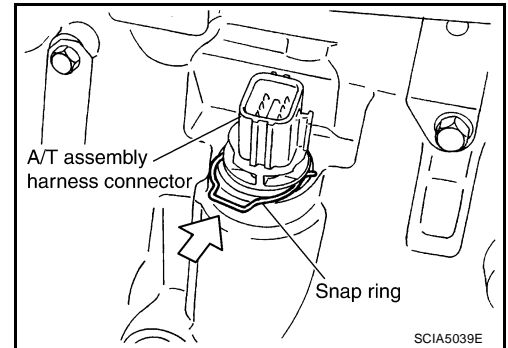

## A/T FLUID TEMPERATURE SENSOR 2 REMOVAL AND INSTALLATION

### Removal

1. Disconnect negative battery terminal.
2. Drain A/T fluid. Refer to [AT-12, "A/T FLUID"](#).
3. Remove oil pan and oil pan gasket. Refer to [AT-226, "Removal"](#).
4. Straighten terminal clip to free A/T fluid temperature sensor 2 harness.
5. Disconnect A/T fluid temperature sensor 2 connector.

**CAUTION:**  
Do not damage connector.

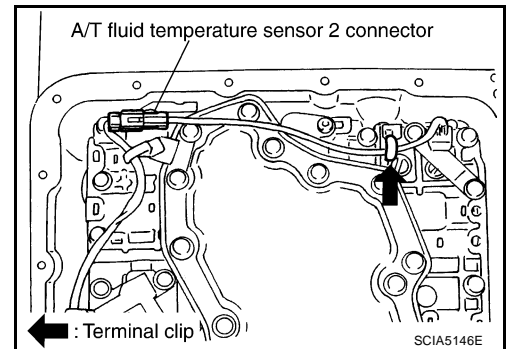

6. Remove A/T fluid temperature sensor 2 with bracket from control valve with TCM.

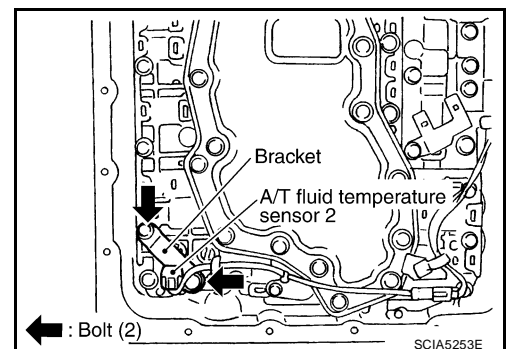

## ON-VEHICLE SERVICE

7. Remove bracket from A/T fluid temperature sensor 2.

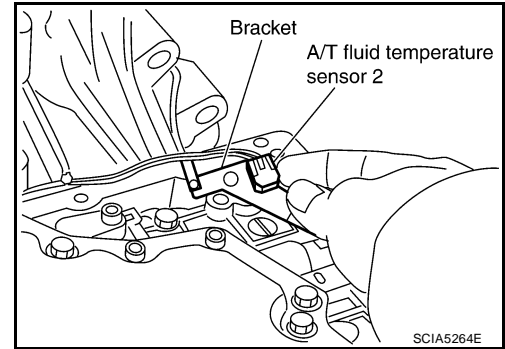

### Installation

#### **CAUTION:**

After completing installation, check for A/T fluid leakage and fluid level. Refer to [AT-12, "A/T FLUID"](#).

1. Install A/T fluid temperature sensor 2 to bracket.

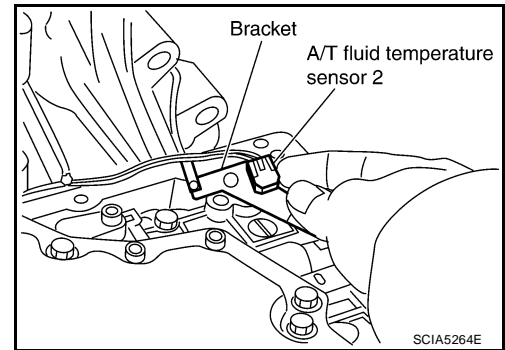

2. Install A/T fluid temperature sensor 2 (with bracket) in control valve with TCM. Tighten A/T fluid temperature sensor 2 bolt to the specified torque. Refer to [AT-228, "COMPONENTS"](#).

#### **CAUTION:**

Adjust bolt hole of bracket to bolt hole of control valve with TCM.

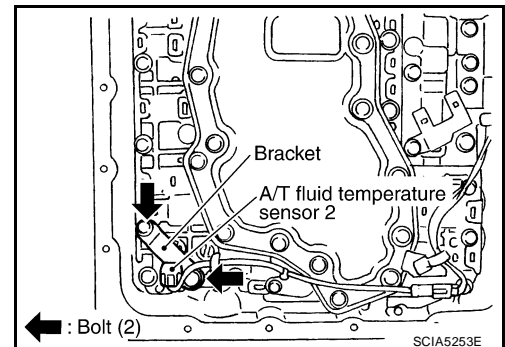

3. Connect A/T fluid temperature sensor 2 connector.
4. Securely fasten A/T temperature sensor 2 harness with terminal clip.

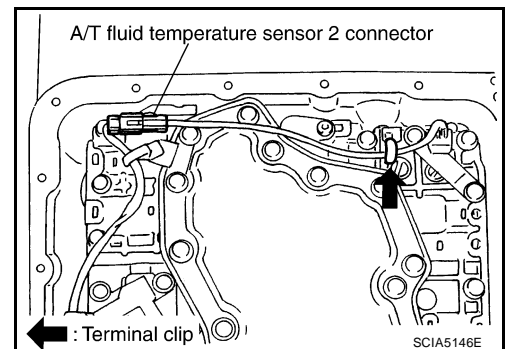

5. Install oil pan to transmission case. Refer to [AT-226, "Installation"](#).
6. Connect the negative battery terminal.

## Rear Oil Seal REMOVAL AND INSTALLATION

### Removal

1. Remove rear propeller shaft. Refer to [PR-10, "Removal and Installation"](#) .
2. Remove transfer from transmission (4WD models). Refer to [TF-111, "Removal and Installation"](#) .
3. Remove rear oil seal using suitable tool.

**CAUTION:**

**Do not scratch rear extension assembly (2WD models) or adapter case assembly (4WD models).**

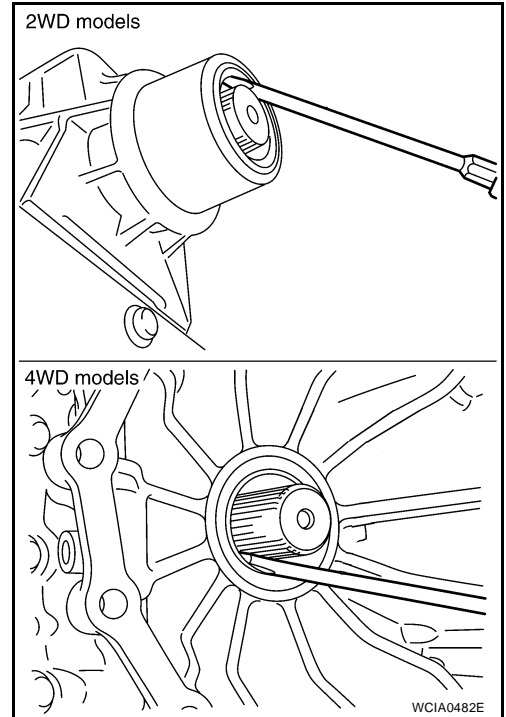

### Installation

**CAUTION:**

**After completing installation, check for A/T fluid leakage and fluid level. Refer to [AT-12, "A/T FLUID"](#) .**

1. Install new rear oil seal until it is flush with component face into the extension case (2WD models) using Tool or adapter case (4WD models) using suitable tool.

**Tool number** : ST33400001 (J-26082)

**CAUTION:**

- Apply ATF to rear oil seal.
- Do not reuse rear oil seal.

2. Install transfer to transmission (4WD models). Refer to [TF-111, "Removal and Installation"](#) .
3. Install rear propeller shaft. Refer to [PR-10, "Removal and Installation"](#) .

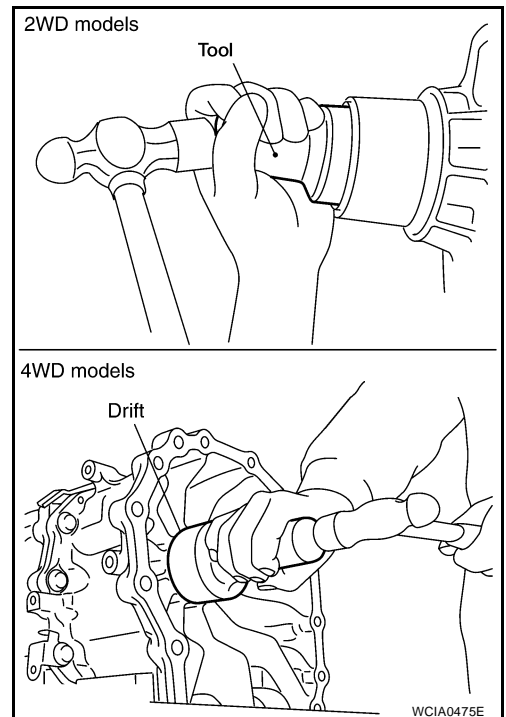

A  
B  
AT  
D  
E  
F  
G  
H  
I  
J  
K  
L  
M

# AIR BREATHER HOSE

## AIR BREATHER HOSE

PF3:31098

### Removal and Installation for QR25DE Engine

ECS00DJ6

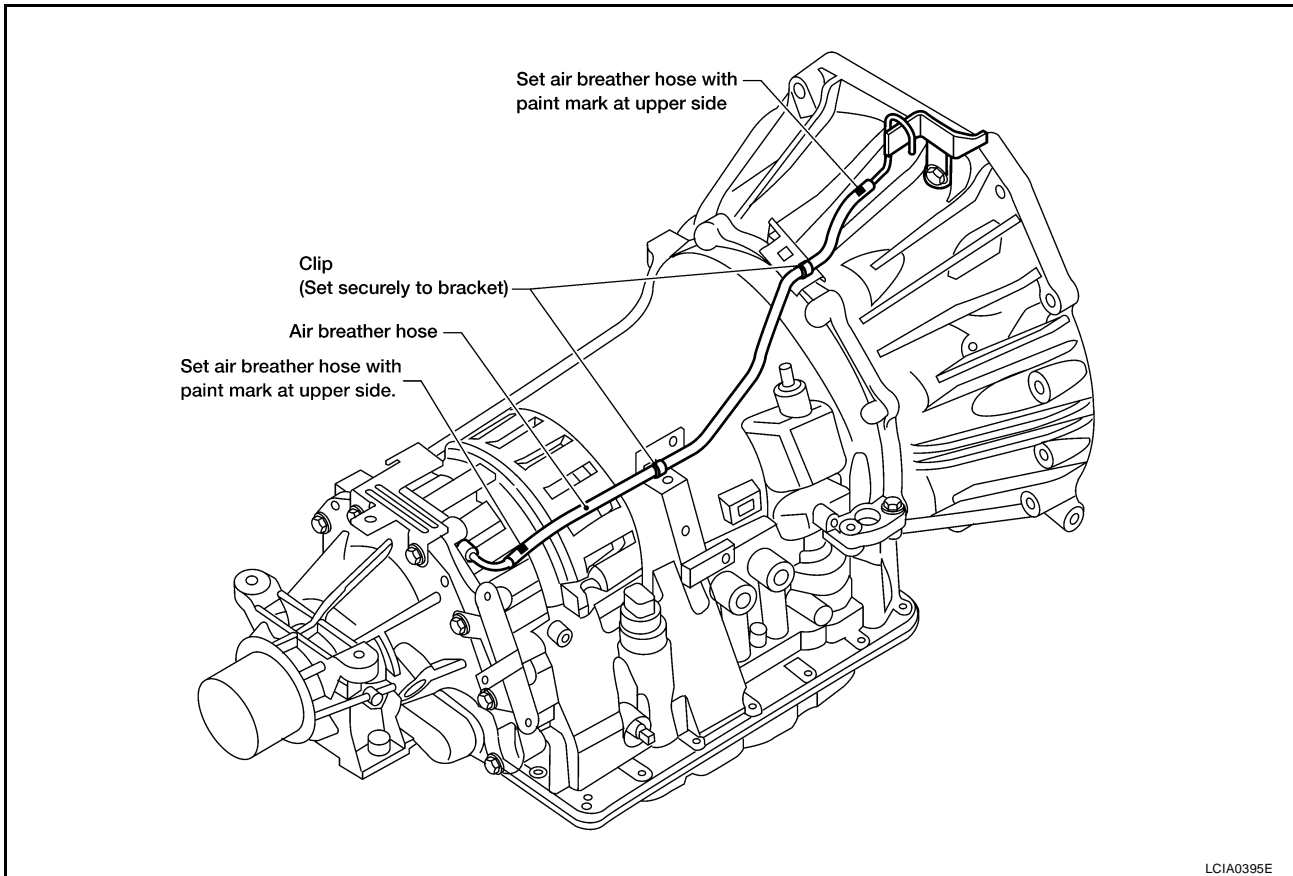

#### **CAUTION:**

- When installing an air breather hose, do not to crush or block by folding or bending the hose.
- When inserting a hose to the transmission tube, be sure to insert it fully until its end reaches the tube bend portion.

# AIR BREATHER HOSE

## Removal and Installation for VQ40DE Engine

UCS0048W

### 2WD Models

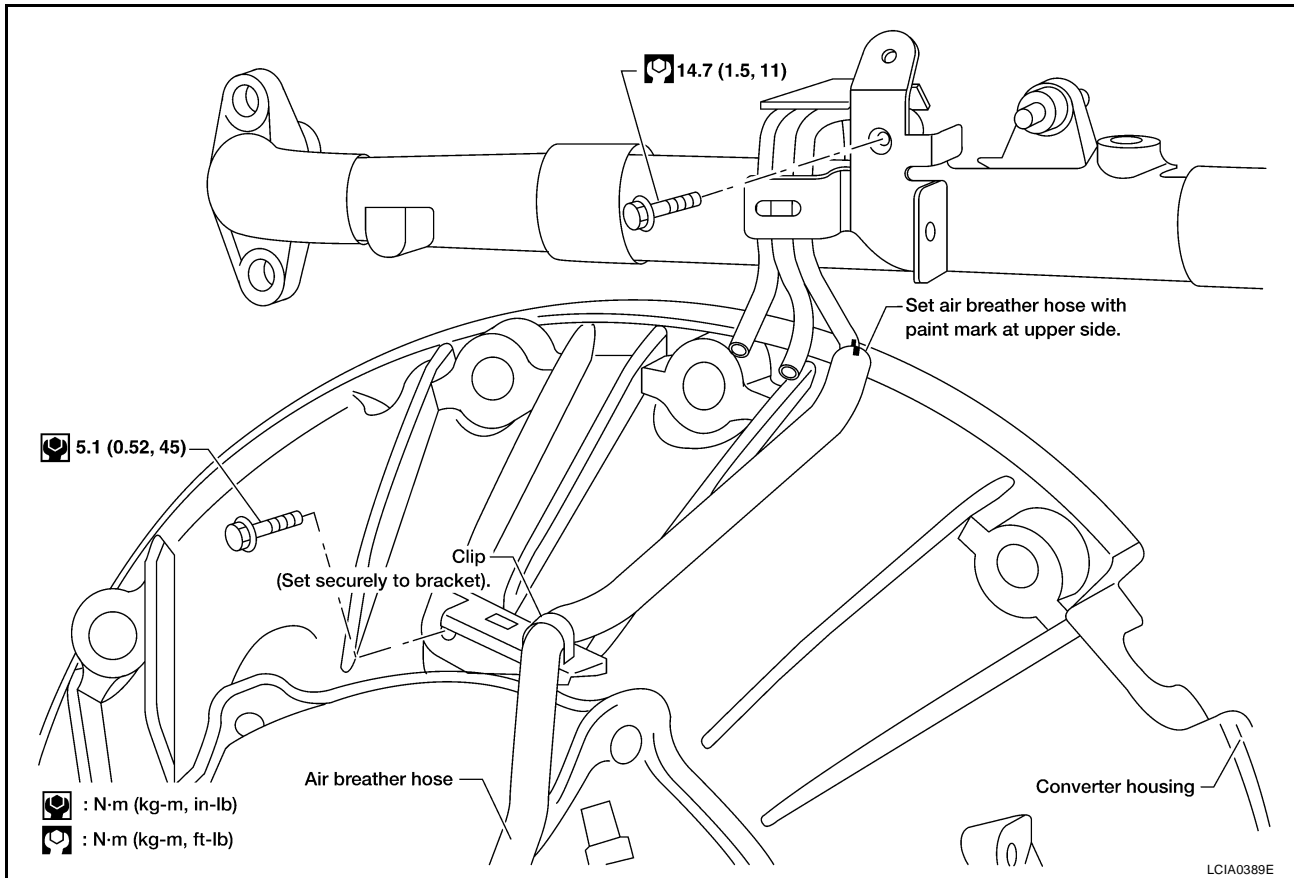

### CAUTION:

- When installing an air breather hose, do not to crush or block by folding or bending the hose.
- When inserting a hose to the transmission tube, be sure to insert it fully until its end reaches the tube bend portion.

A  
B  
AT  
D  
E  
F  
G  
H  
I  
J  
K  
L  
M

# AIR BREATHER HOSE

## 4WD Models

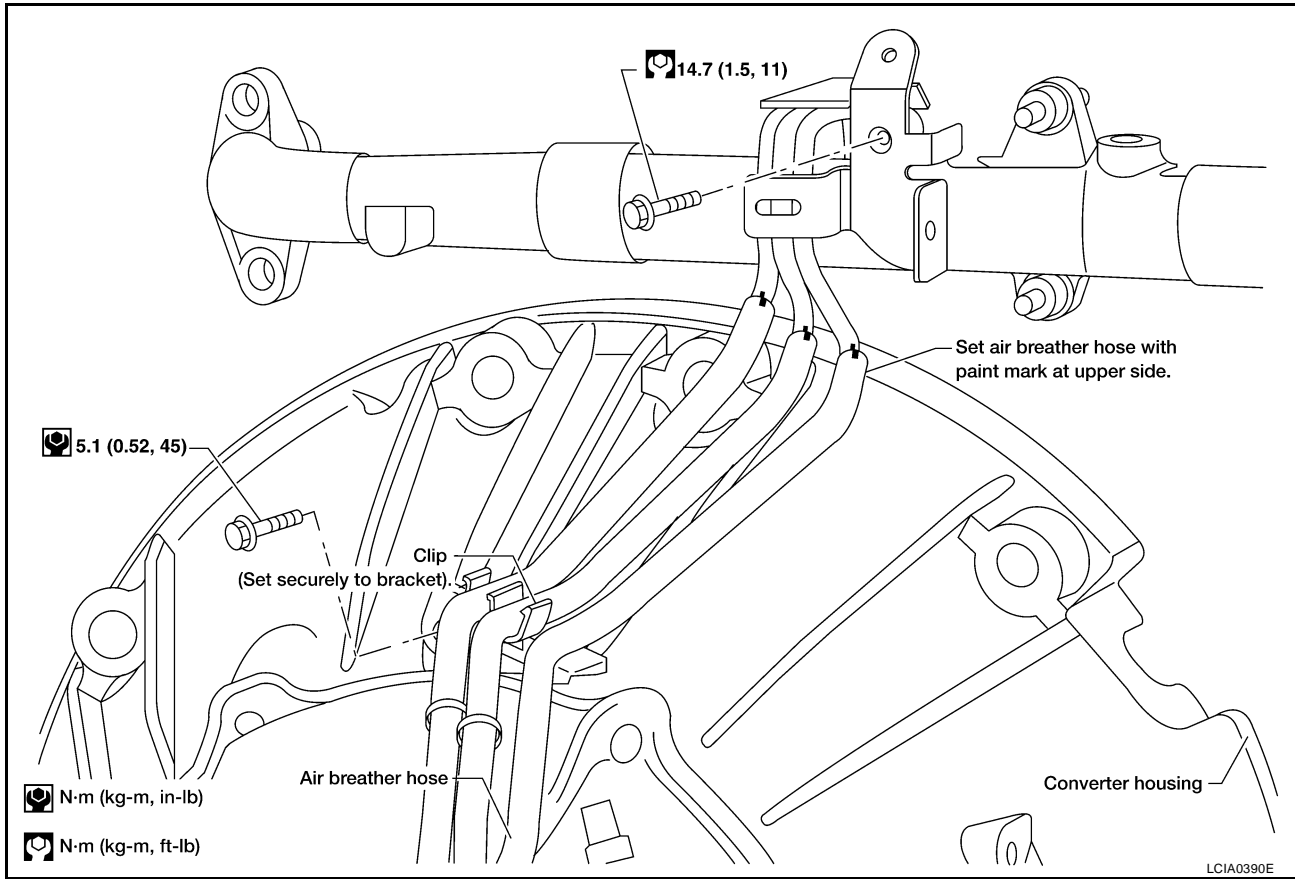

### CAUTION:

- When installing an air breather hose, do not to crush or block by folding or bending the hose.
- When inserting a hose to the transmission tube, be sure to insert it fully until its end reaches the tube bend portion.



# A/T FLUID COOLER

PFP:21600

## A/T FLUID COOLER

### Removal and Installation

ECS00FS0

Refer to the figure below for A/T cooler removal and installation.

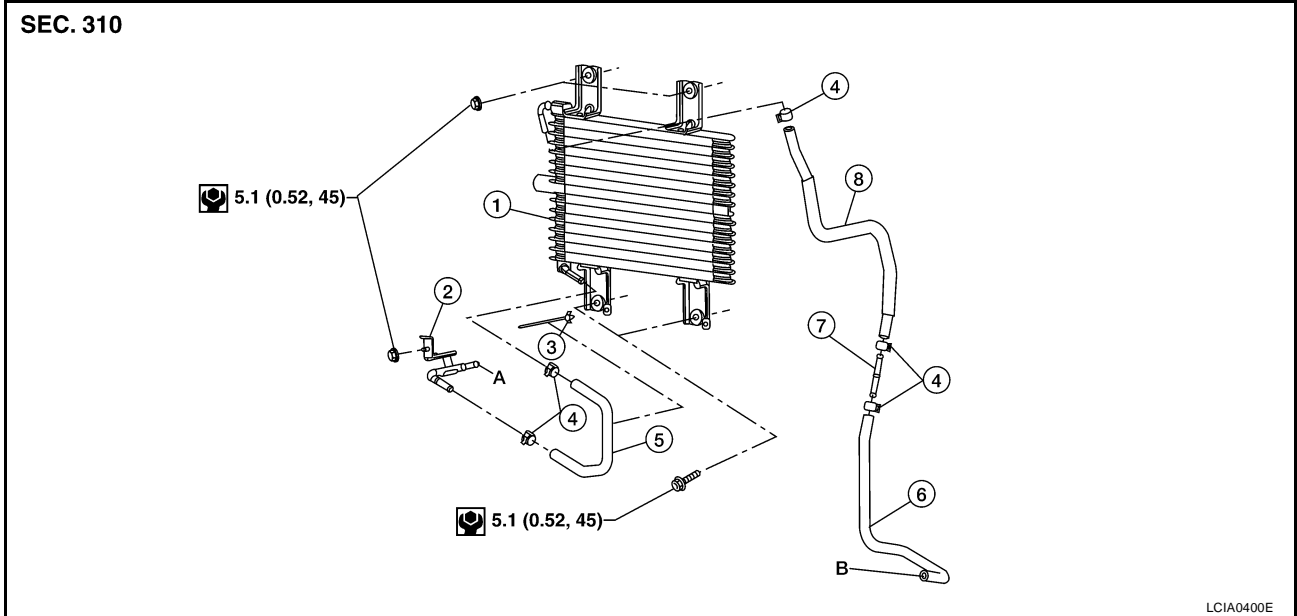

- |                     |                        |                    |
|---------------------|------------------------|--------------------|
| 1. A/T fluid cooler | 2. Fluid cooler tube   | 3. Clip            |
| 4. Hose clamp       | 5. Cooler hose (lower) | 6. Cooler hose     |
| 7. Tube joint       | 8. Cooler hose (upper) | A. To transmission |
| B. From radiator    |                        |                    |

- After completing installation, check fluid leakage and fluid level. Refer to [AT-12, "A/T FLUID"](#).

# TRANSMISSION ASSEMBLY

PF3:31020

ECS00DJ7

## TRANSMISSION ASSEMBLY

### Components

QR25DE

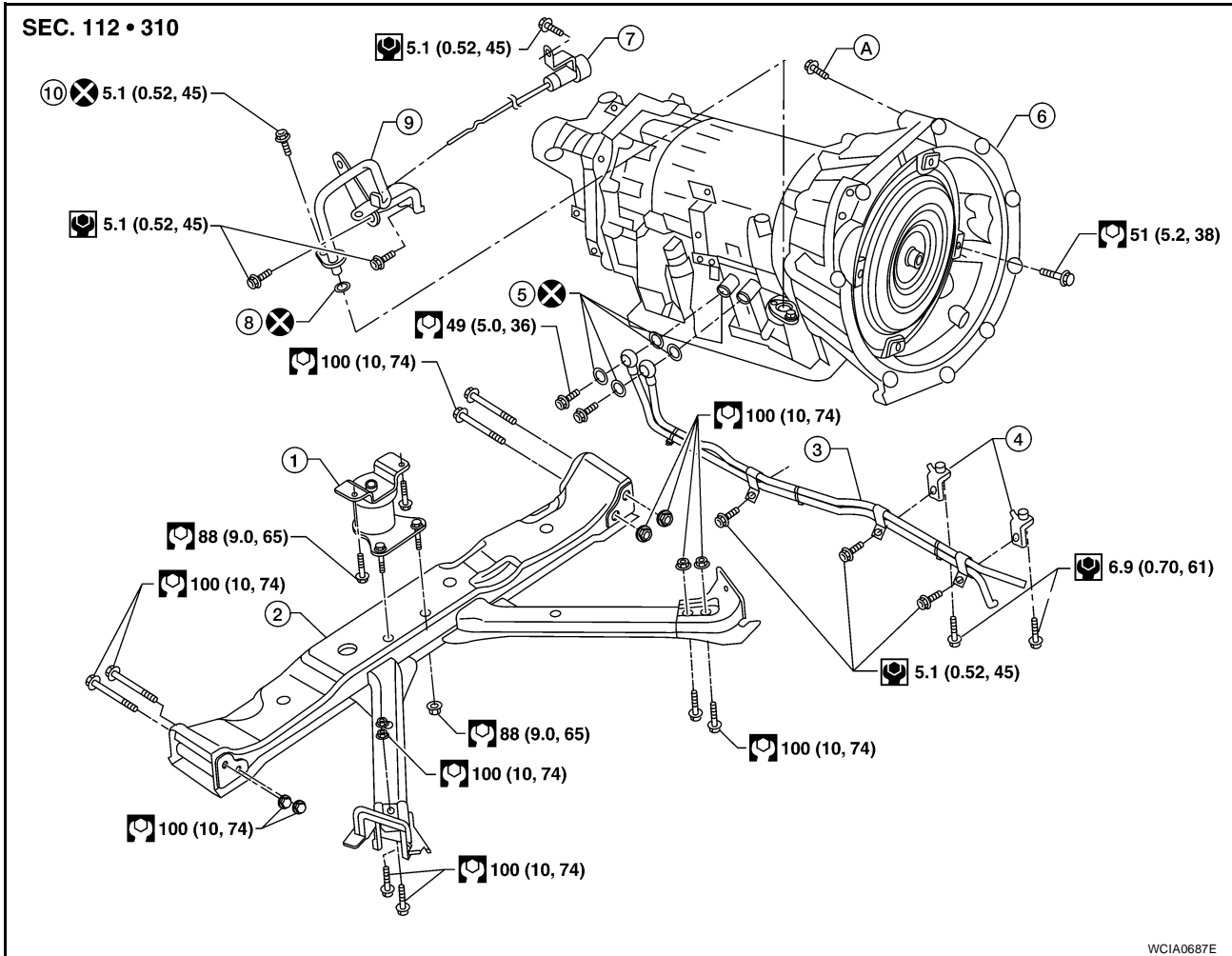

WCIA0687E

- |                                  |  |                            |
|----------------------------------|--|----------------------------|
| 1. Insulator                     | 2. A/T cross member                                  | 3. A/T fluid cooler tube   |
| 4. A/T fluid cooler tube bracket | 5. Copper washers                                    | 6. Transmission assembly   |
| 7. A/T fluid level gauge         | 8. O-ring  | 9. A/T fluid charging pipe |
| 10. Self-sealing bolt            | A. Refer to <a href="#">AT-246, "INSTALLATION"</a> . |                            |

# TRANSMISSION ASSEMBLY

## VQ40DE 2WD Models

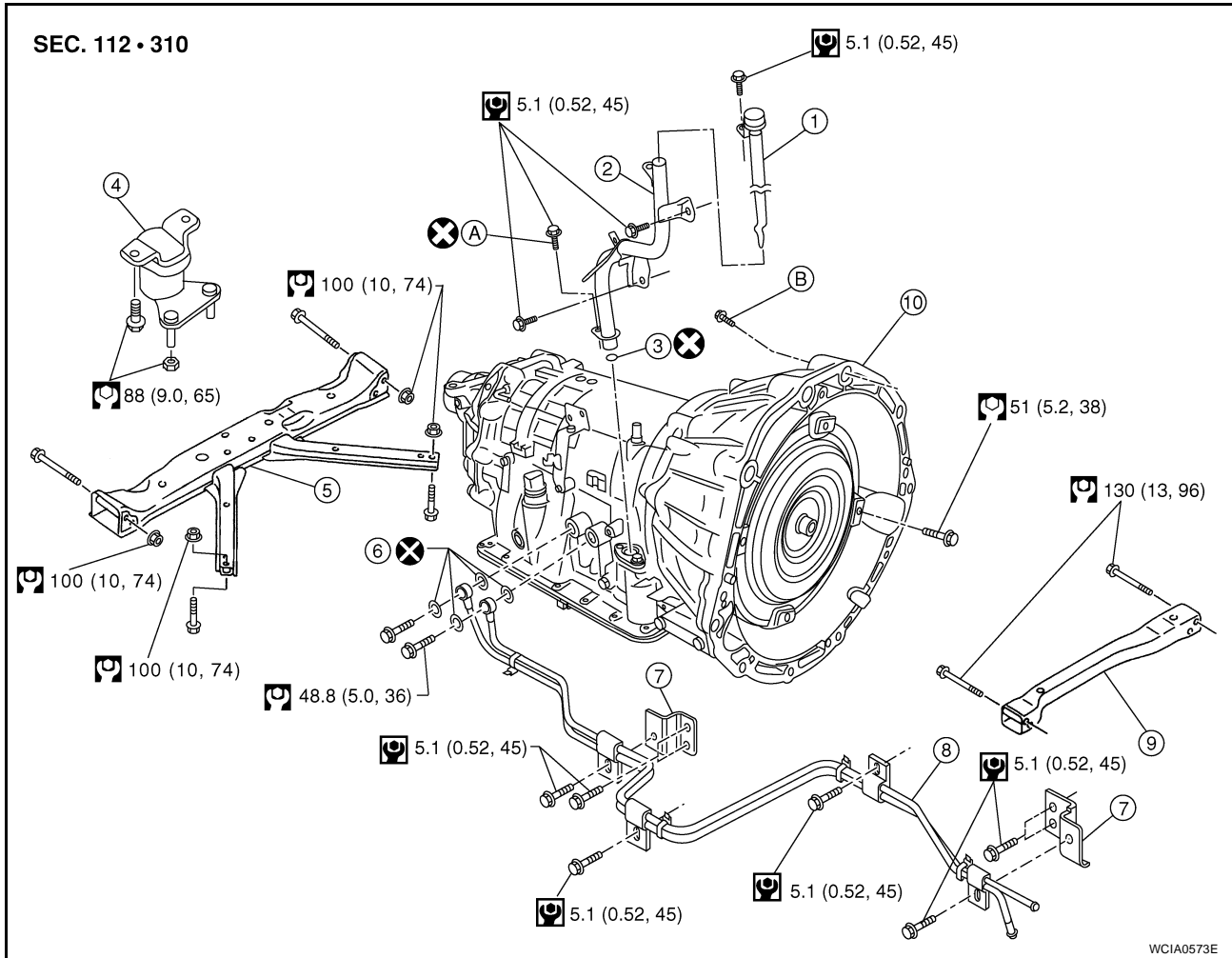

- |                           |                            |                           |
|---------------------------|----------------------------|---------------------------|
| 1. A/T fluid level gauge  | 2. A/T fluid charging pipe | 3. O-ring                 |
| 4. Insulator              | 5. A/T crossmember         | 6. Copper washer          |
| 7. Bracket                | 8. A/T fluid cooler tube   | 9. Front crossmember      |
| 10. Transmission assembly | A. Self-sealing bolt       | B. Refer to installation. |

A

B

AT

D

E

F

G

H

I

J

K

L

M

# TRANSMISSION ASSEMBLY

## VQ40DE 4WD Models

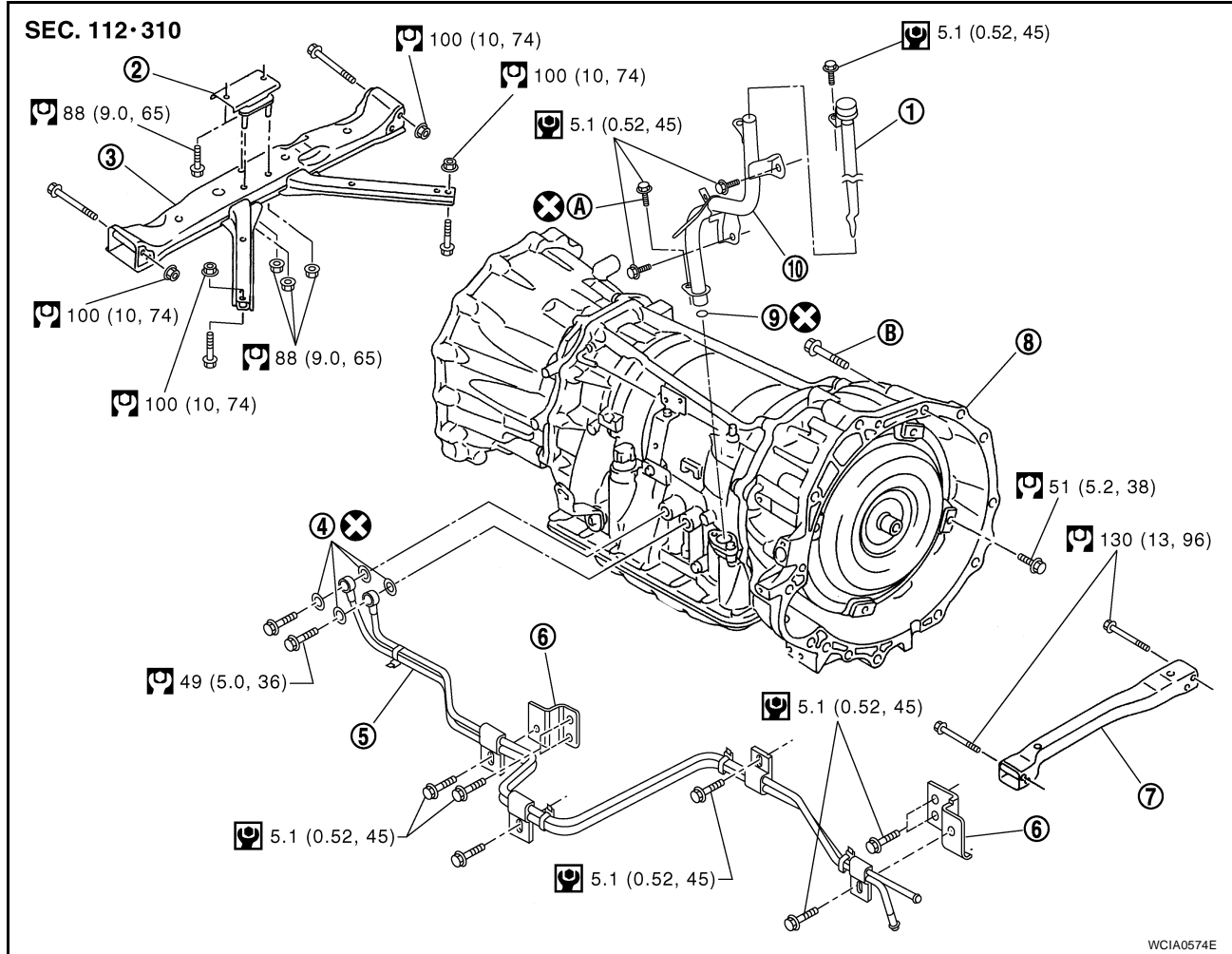

WCIA0574E

- |                             |                          |                           |
|-----------------------------|--------------------------|---------------------------|
| 1. A/T fluid level gauge    | 2. Insulator             | 3. A/T crossmember        |
| 4. Copper washers           | 5. A/T fluid cooler tube | 6. Bracket                |
| 7. Front crossmember        | 8. Transmission assembly | 9. O-ring                 |
| 10. A/T fluid charging pipe | A. Self-sealing bolt     | B. Refer to installation. |

# TRANSMISSION ASSEMBLY

ECS00DJB

## Removal and Installation for QR25DE

### REMOVAL

#### CAUTION:

When removing the A/T assembly from engine, first remove the crankshaft position sensor (POS) from the A/T assembly.

1. Disconnect the negative battery terminal.
2. Remove the A/T fluid level gauge.
3. Remove the LH fender protector.
4. Remove the crankshaft position sensor (POS) from the A/T assembly.

#### CAUTION:

- Do not subject it to impact by dropping or hitting it.
- Do not disassemble.
- Do not allow metal filings or debris to get on the sensor's front edge magnetic area.
- Do not place in an area affected by magnetism.

5. Remove the under cover using power tool.
6. Partially drain the A/T fluid. Refer to [AT-12, "A/T FLUID"](#) .
7. Remove the front cross member using power tool.
8. Remove the starter.
9. Remove the rear propeller shaft. Refer to [PR-10, "Removal and Installation"](#) .
10. Remove the A/T selector control cable and bracket from the A/T.
11. Disconnect the A/T fluid cooler tubes from the A/T assembly.
12. Remove the dust cover from the converter housing.
13. Turn the crankshaft to access and remove the four bolts for the drive plate and torque converter.

#### CAUTION:

When turning the crankshaft, turn it clockwise as viewed from the front of the engine.

14. Support the A/T assembly using a transmission jack.

#### CAUTION:

When setting the transmission jack, be careful not to allow it to collide against the drain plug.

15. Remove the nuts securing the insulator to the cross member.
16. Remove the cross member using power tool.

#### WARNING:

Support the transmission using suitable jack.

17. Tilt the transmission slightly to gain clearance between the body and the transmission, then disconnect the air breather hose.
18. Disconnect the A/T assembly harness connector.
19. Remove the wiring harness from the retainers.
20. Remove the A/T fluid charging pipe.
21. Plug any openings such as the A/T fluid charging pipe hole.
22. Remove the A/T assembly to engine bolts using power tool.

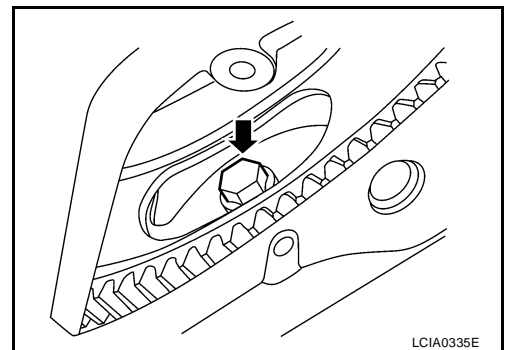
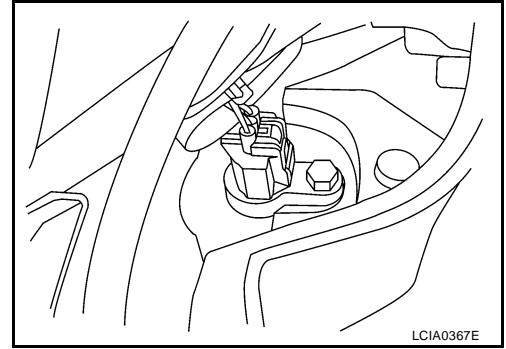

A

B

AT

D

E

F

G

H

I

J

K

L

M

# TRANSMISSION ASSEMBLY

23. Remove A/T assembly from the vehicle using Tool.

**Tool number** : — (J-47002)

**CAUTION:**

- Secure the torque converter to prevent it from dropping.
- Secure the A/T assembly to a transmission jack.

**NOTE:**

The actual special service Tool may differ from Tool shown.

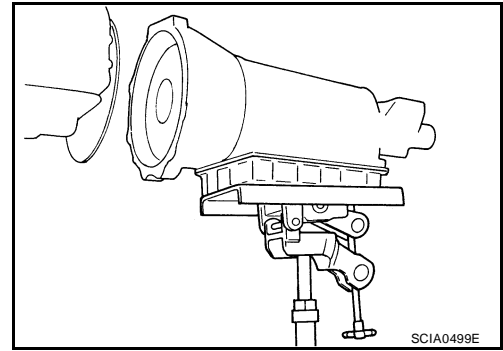

## INSPECTION

### Installation and Inspection of Torque Converter

- After inserting a torque converter to a transmission, be sure to check dimension A to ensure it is within the reference value limit.

**Dimension A** : 25.0 mm (0.98 in) or more

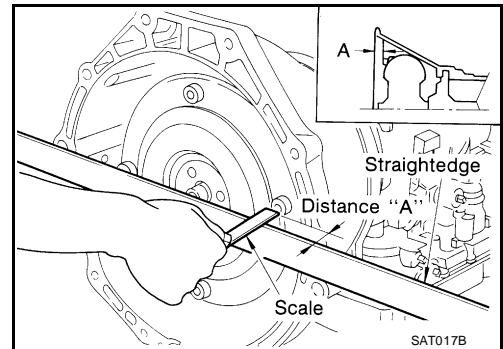

## INSTALLATION

Installation is in the reverse order of the removal.

**CAUTION:**

- When replacing an engine or transmission you must make sure the dowels are installed correctly during re-assembly.
- Improper alignment caused by missing dowels may cause vibration, oil leaks or breakage of drivetrain components.
- Do not reuse O-rings and copper washers. Refer to [AT-242, "Components"](#) .
- When turning crankshaft, turn it clockwise as viewed from the front of the engine.
- After converter is installed to drive plate, rotate crankshaft several turns and check to be sure that transmission rotates freely without binding.
- When tightening the bolts for the torque converter while securing the crankshaft pulley bolt, be sure to confirm the tightening torque of the crankshaft pulley bolt. Refer to [EM-165, "TIMING CHAIN"](#) .
- When installing transmission to the engine, install the bolts in accordance with the standard below.

Bolt No.	1	2	3
Quantity	4	1	6
Bolt length "ℓ" mm (in)	60 (2.36)		65 (2.56)
Tightening torque N·m (kg·m, ft·lb)	35 (3.6, 26)		75 (7.7, 55)

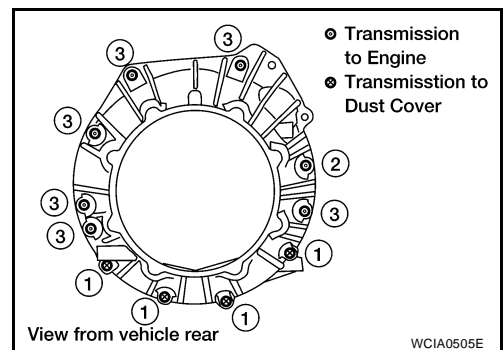

## TRANSMISSION ASSEMBLY

- When installing the drive plate to torque converter bolts, align the positions of bolts for drive plate with those of the torque converter and temporarily tighten the bolts. Then tighten the bolts with the specified torque.
- After completing installation, fill A/T with fluid and check fluid leakage, fluid level, and the positions of A/T. Refer to [AT-12, "A/T FLUID"](#) , [AT-217, "Checking of A/T Position"](#) and [AT-217, "Adjustment of A/T Position"](#) .

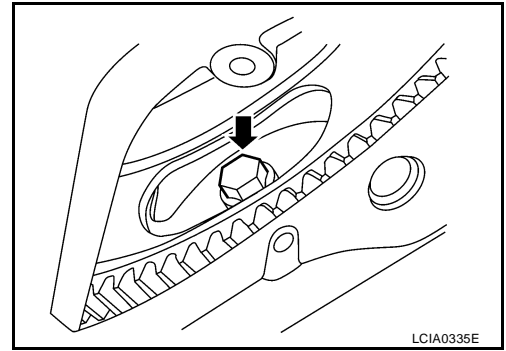

A

B

AT

D

E

F

G

H

I

J

K

L

M

# TRANSMISSION ASSEMBLY

UCS0048X

## Removal and Installation for VQ40DE 2WD Models

### REMOVAL

#### CAUTION:

When removing the A/T assembly from engine, first remove the crankshaft position sensor (POS) from the A/T assembly.

1. Disconnect the negative battery terminal.
2. Remove the A/T fluid level gauge.
3. Remove the LH fender protector.
4. Remove the crankshaft position sensor (POS) from the A/T assembly.

#### CAUTION:

- Do not subject it to impact by dropping or hitting it.
- Do not disassemble.
- Do not allow metal filings or debris to get on the sensor's front edge magnetic area.
- Do not place in an area affected by magnetism.

5. Remove the under covers using power tool.
6. Partially drain the A/T fluid. Refer to [AT-12, "A/T FLUID"](#) .
7. Remove the front cross member using power tool.
8. Remove the starter.
9. Remove the rear propeller shaft. Refer to [PR-10, "Removal and Installation"](#) .
10. Remove the left and right front exhaust tubes. Refer to [EX-5, "Removal and Installation"](#) .
11. Remove the A/T selector control cable and bracket from the A/T.
12. Disconnect the A/T fluid cooler tubes from the A/T assembly.
13. Remove the dust cover from the converter housing.
14. Turn the crankshaft to access and remove the four bolts for the drive plate and torque converter.

#### CAUTION:

When turning the crankshaft, turn it clockwise as viewed from the front of the engine.

15. Support the A/T assembly using a transmission jack.

#### CAUTION:

When setting the transmission jack, be careful not to allow it to collide against the drain plug.

16. Remove the nuts securing the insulator to the cross member.
17. Remove the cross member using power tool.
18. Tilt the transmission slightly to gain clearance between the body and the transmission, then disconnect the air breather hose.
19. Disconnect the A/T assembly harness connector.
20. Remove the wiring harness from the retainers.
21. Remove the A/T fluid charging pipe.
22. Plug any openings such as the A/T fluid charging pipe hole.
23. Remove the A/T assembly to engine bolts using power tool.

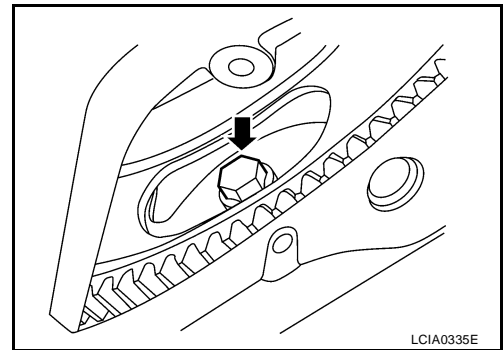
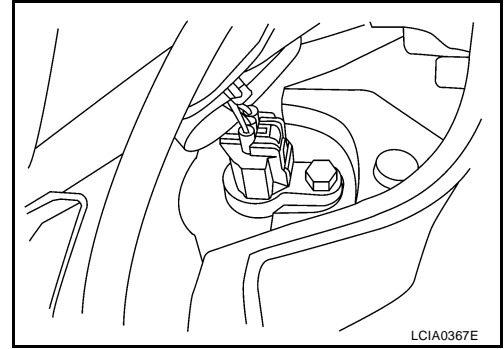



# TRANSMISSION ASSEMBLY

24. Remove A/T assembly from the vehicle using Tool.

**Tool number** : — (J-47002)

**CAUTION:**

- Secure the torque converter to prevent it from dropping.
- Secure the A/T assembly to a transmission jack.

**NOTE:**

The actual special service Tool may differ from Tool shown.

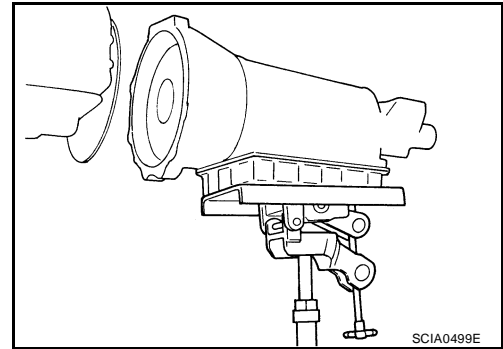

## INSPECTION

### Installation and Inspection of Torque Converter

- After inserting a torque converter to a transmission, be sure to check dimension A to ensure it is within the reference value limit.

**Dimension A** : 25.0 mm (0.98 in) or more

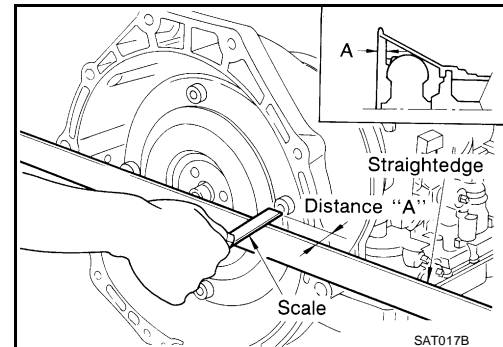

## INSTALLATION

Installation is in the reverse order of the removal.

**CAUTION:**

- When replacing an engine or transmission you must make sure the dowels are installed correctly during re-assembly.
- Improper alignment caused by missing dowels may cause vibration, oil leaks or breakage of drivetrain components.
- Do not reuse O-rings and copper washers. Refer to [AT-242, "Components"](#) .
- When turning crankshaft, turn it clockwise as viewed from the front of the engine.
- After converter is installed to drive plate, rotate crankshaft several turns and check to be sure that transmission rotates freely without binding.
- When tightening the bolts for the torque converter while securing the crankshaft pulley bolt, be sure to confirm the tightening torque of the crankshaft pulley bolt. Refer to [EM-165, "TIMING CHAIN"](#) .
- When installing transmission to the engine, tighten the bolts to the specified torque using sequence shown.

**Transmission bolts** : 74 N·m (7.5 kg·m, 55 ft·lb)

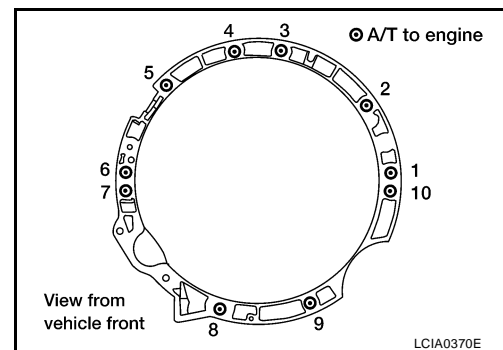

## TRANSMISSION ASSEMBLY

- When installing the drive plate to torque converter bolts, align the positions of bolts for drive plate with those of the torque converter and temporarily tighten the bolts. Then tighten the bolts with the specified torque.
- After completing installation, fill A/T with fluid and check fluid leakage, fluid level, and the positions of A/T. Refer to [AT-12, "A/T FLUID"](#) , [AT-217, "Checking of A/T Position"](#) and [AT-217, "Adjustment of A/T Position"](#) .

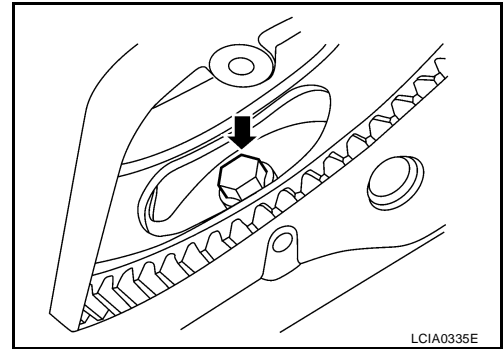

# TRANSMISSION ASSEMBLY

UCS0048Y

## Removal and Installation for VQ40DE 4WD Models

### REMOVAL

#### CAUTION:

When removing the A/T assembly from engine, first remove the crankshaft position sensor (POS) from the A/T assembly.

1. Disconnect the negative battery terminal.
2. Remove the A/T fluid level gauge.
3. Remove the LH fender protector.
4. Remove the crankshaft position sensor (POS) from the A/T assembly.

#### CAUTION:

- Do not subject it to impact by dropping or hitting it.
- Do not disassemble.
- Do not allow metal filings or debris to get on the sensor's front edge magnetic area.
- Do not place in an area affected by magnetism.

5. Remove the air dam.
6. Remove the front and rear engine under cover using power tool.
7. Partially drain the A/T fluid. Refer to [AT-12, "A/T FLUID"](#).
8. Remove the front cross member using power tool.
9. Remove the starter motor.
10. Remove the front and rear propeller shafts. Refer to [PR-5, "Removal and Installation"](#), [PR-10, "Removal and Installation"](#).
11. Remove the left and right front exhaust tubes. Refer to [EX-5, "Removal and Installation"](#).

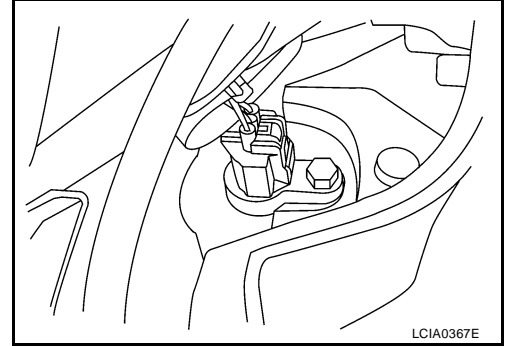

12. Remove the A/T selector control cable and bracket from the A/T.
13. Disconnect the fluid cooler tubes from the A/T assembly.
14. Remove the dust cover from the converter housing.
15. Turn the crankshaft to access and remove the four bolts for the drive plate and torque converter.

#### CAUTION:

When turning the crankshaft, turn it clockwise as viewed from the front of the engine.

16. Support the A/T assembly using a transmission jack.

#### CAUTION:

When setting the transmission jack, be careful not to allow it to collide against the drain plug.

17. Remove the nuts securing the insulator to the crossmember.
18. Remove the crossmember using power tool.
19. Tilt the transmission slightly to gain clearance between the body and the transmission, then disconnect the air breather hose.
20. Disconnect the following:
  - A/T assembly harness connector
  - 4LO switch connector
  - Wait detection switch connector
  - ATP switch connector
  - Transfer control device connector
21. Remove the wiring harness from the retainers.
22. Remove the A/T fluid charging pipe.
23. Plug any openings such as the fluid charging pipe hole.
24. Remove the A/T assembly to engine bolts using power tool.

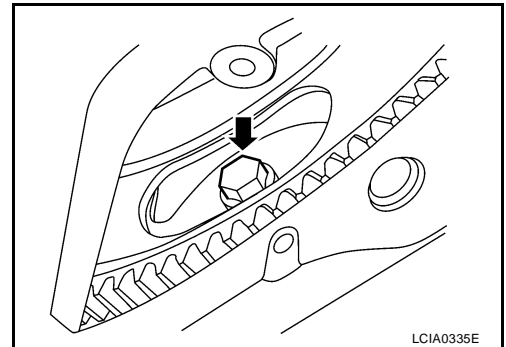

# TRANSMISSION ASSEMBLY

25. Remove A/T assembly with transfer from the vehicle using Tool.

**Tool number** : — (J-47002)

**CAUTION:**

- Secure the torque converter to prevent it from dropping.
- Secure the A/T assembly to a transmission jack.

**NOTE:**

The actual special service Tool may differ from Tool shown.

26. Remove the transfer from the A/T assembly. Refer to [TF-111](#), "[Removal and Installation](#)".

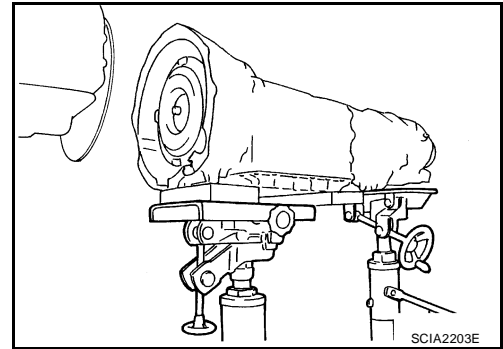

## INSPECTION

### Installation and Inspection of Torque Converter

- After inserting a torque converter to a transmission, be sure to check dimension A to ensure it is within the reference value limit.

**Dimension A** : 25.0 mm (0.98 in) or more

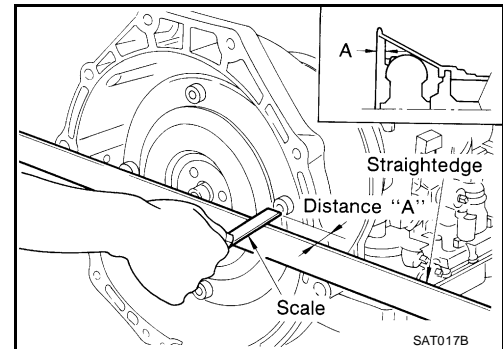

## INSTALLATION

Installation is in the reverse order of removal.

**CAUTION:**

- When replacing an engine or transmission you must make sure the dowels are installed correctly during re-assembly.
- Improper alignment caused by missing dowels may cause vibration, oil leaks or breakage of drivetrain components.
- Do not reuse O-rings and copper washers. Refer to [AT-242](#), "[Components](#)".
- When turning crankshaft, turn it clockwise as viewed from the front of the engine.
- After converter is installed to drive plate, rotate crankshaft several turns and check to be sure that transmission rotates freely without binding.
- When tightening the bolts for the torque converter while securing the crankshaft pulley bolt, be sure to confirm the tightening torque of the crankshaft pulley bolt. Refer to [EM-165](#), "[TIMING CHAIN](#)".
- When installing transmission to the engine, tighten the bolts to the specified torque using sequence shown.

**Transmission bolts** : 74 N·m (7.5 kg·m, 55 ft·lb)

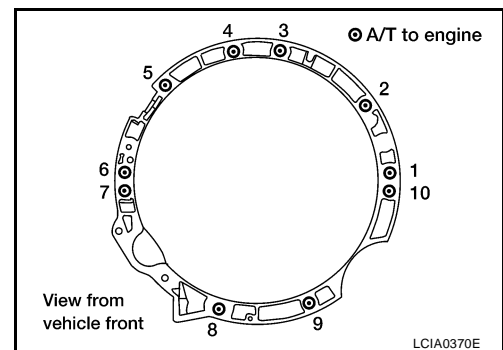

## TRANSMISSION ASSEMBLY

- When installing the drive plate to torque converter bolts, align the positions of bolts for drive plate with those of the torque converter and temporarily tighten the bolts. Then tighten the bolts with the specified torque.
- After completing installation, fill A/T with fluid and check fluid leakage, fluid level, and the positions of A/T. Refer to [AT-12, "A/T FLUID"](#) , [AT-217, "Checking of A/T Position"](#) and [AT-217, "Adjustment of A/T Position"](#) .

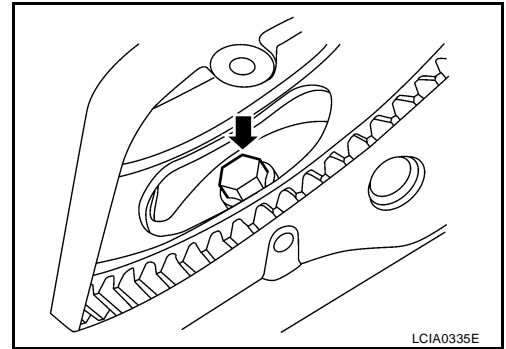

A

B

AT

D

E

F

G

H

I

J

K

L

M

# OVERHAUL

PF0:0000

UCS0048Z

## OVERHAUL Components

SEC.311•313•314•315

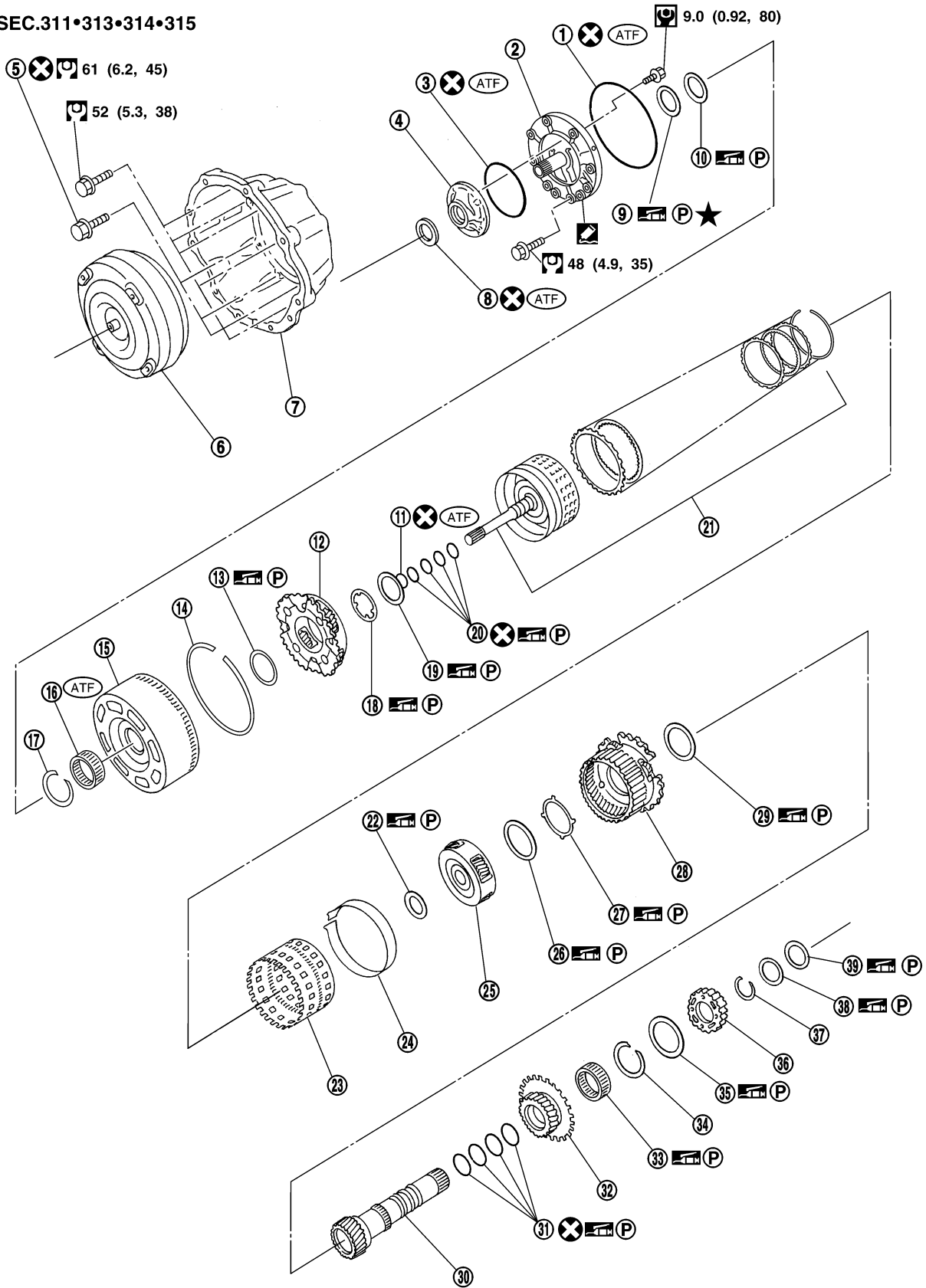

WCIA0661E

# OVERHAUL

---

1. O-ring	2. Oil pump cover	3. O-ring	A
4. Oil pump housing	5. Self-sealing bolt	6. Torque converter	
7. Converter housing	8. Oil pump housing oil seal	9. Bearing race	
10. Needle bearing	11. O-ring	12. Front carrier assembly	B
13. Needle bearing	14. Snap ring	15. Front sun gear	
16. 3rd one-way clutch	17. Snap ring	18. Bearing race	
19. Needle bearing	20. Seal ring	21. Input clutch assembly	AT
22. Needle bearing	23. Rear internal gear	24. Brake band	
25. Mid carrier assembly	26. Needle bearing	27. Bearing race	
28. Rear carrier assembly	29. Needle bearing	30. Mid sun gear	D
31. Seal ring	32. Rear sun gear	33. 1st one-way clutch	
34. Snap ring	35. Needle bearing	36. High and low reverse clutch hub	
37. Snap ring	38. Bearing race	39. Needle bearing	E

F

G

H

I

J

K

L

M

# OVERHAUL

## QR25DE Models

SEC.315•316

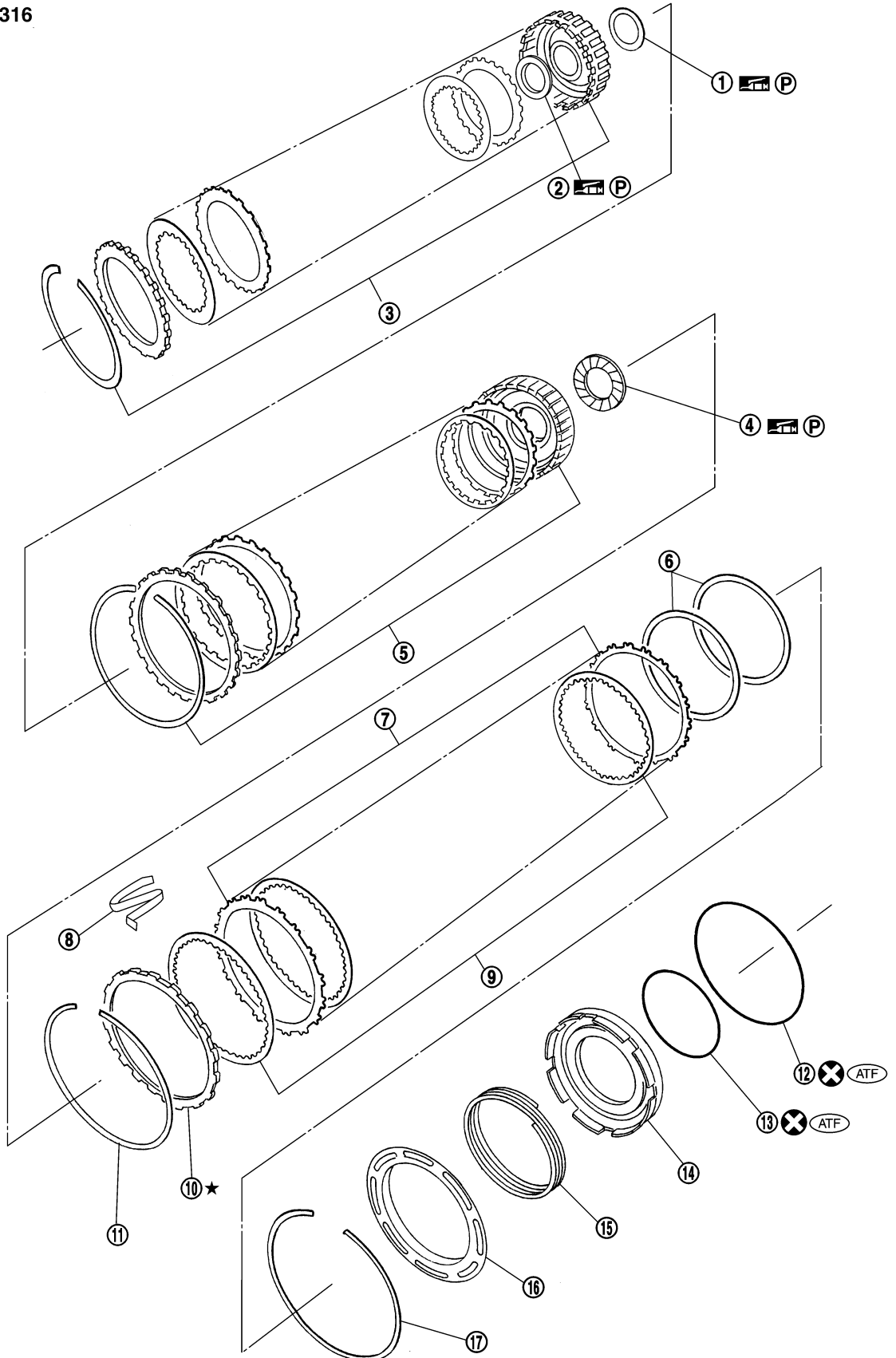

- 1. Needle bearing
- 4. Needle bearing

- 2. Bearing race
- 5. Direct clutch assembly

- 3. High and low reverse clutch assembly
- 6. Reverse brake dish plate

WCIA0575E



# OVERHAUL

- 
- |                               |                                   |                          |
|-------------------------------|-----------------------------------|--------------------------|
| 7. Reverse brake dish plate   | 8. Reverse brake driven plate     | 9. N-spring              |
| 10. Reverse brake drive plate | 11. Reverse brake retaining plate | 12. Snap ring            |
| 13. D-ring                    | 14. D-ring                        | 15. Reverse brake piston |
| 16. Return spring             | 17. Spring retainer               | 18. Snap ring            |

A

B

AT

D

E

F

G

H

I

J

K

L

M

# OVERHAUL

## VQ40DE Models

SEC.315•316

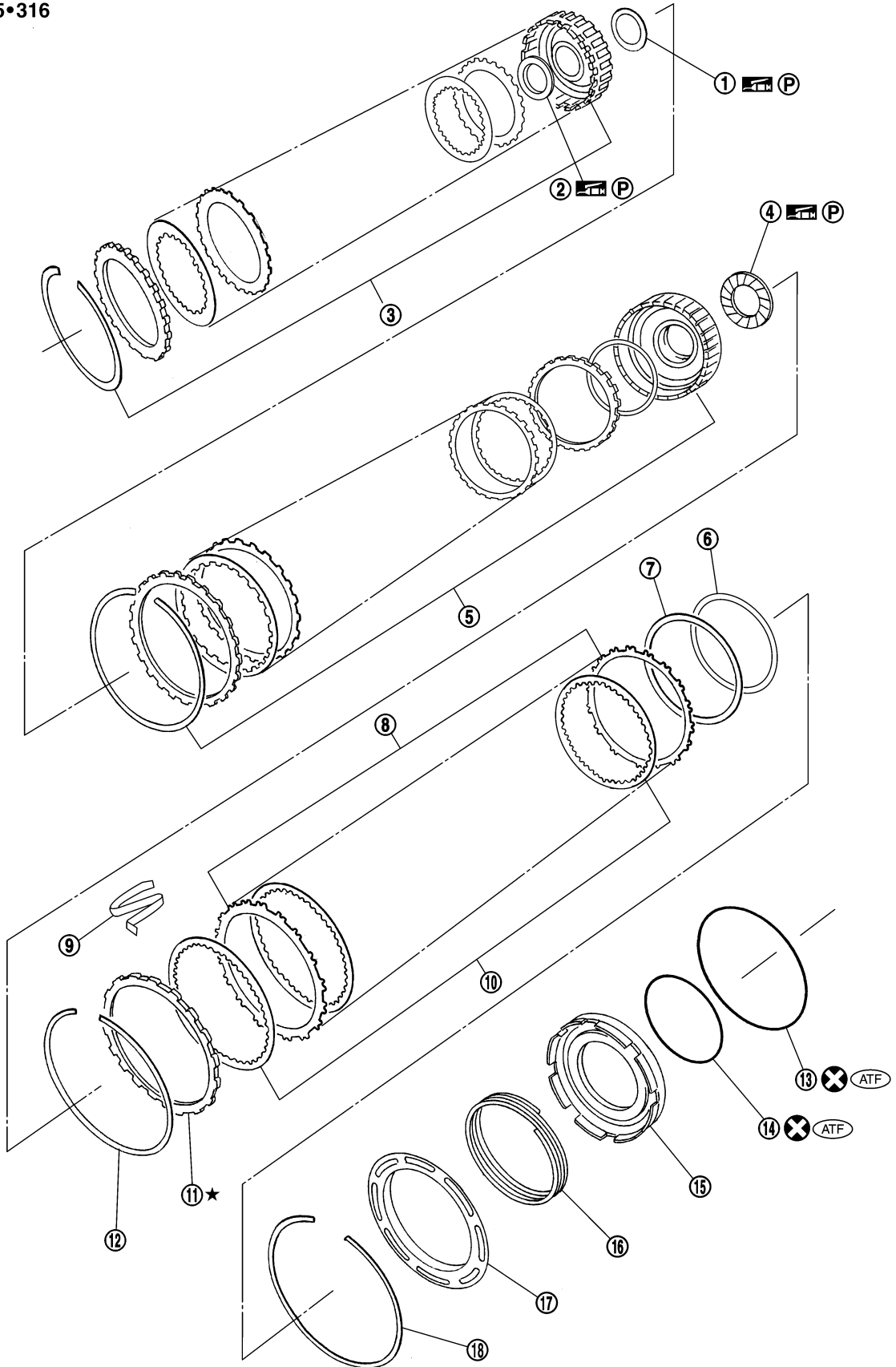

- 1. Needle bearing
- 4. Needle bearing

- 2. Bearing race
- 5. Direct clutch assembly

- 3. High and low reverse clutch assembly
- 6. Reverse brake dish plate

SCIA7001E

# OVERHAUL

- 
- |                               |                                   |                          |
|-------------------------------|-----------------------------------|--------------------------|
| 7. Reverse brake dish plate   | 8. Reverse brake driven plate     | 9. N-spring              |
| 10. Reverse brake drive plate | 11. Reverse brake retaining plate | 12. Snap ring            |
| 13. D-ring                    | 14. D-ring                        | 15. Reverse brake piston |
| 16. Return spring             | 17. Spring retainer               | 18. Snap ring            |

A

B

AT

D

E

F

G

H

I

J

K

L

M

# OVERHAUL

## 2WD Models

SEC.313 • 314 • 315 • 316 • 317 • 319

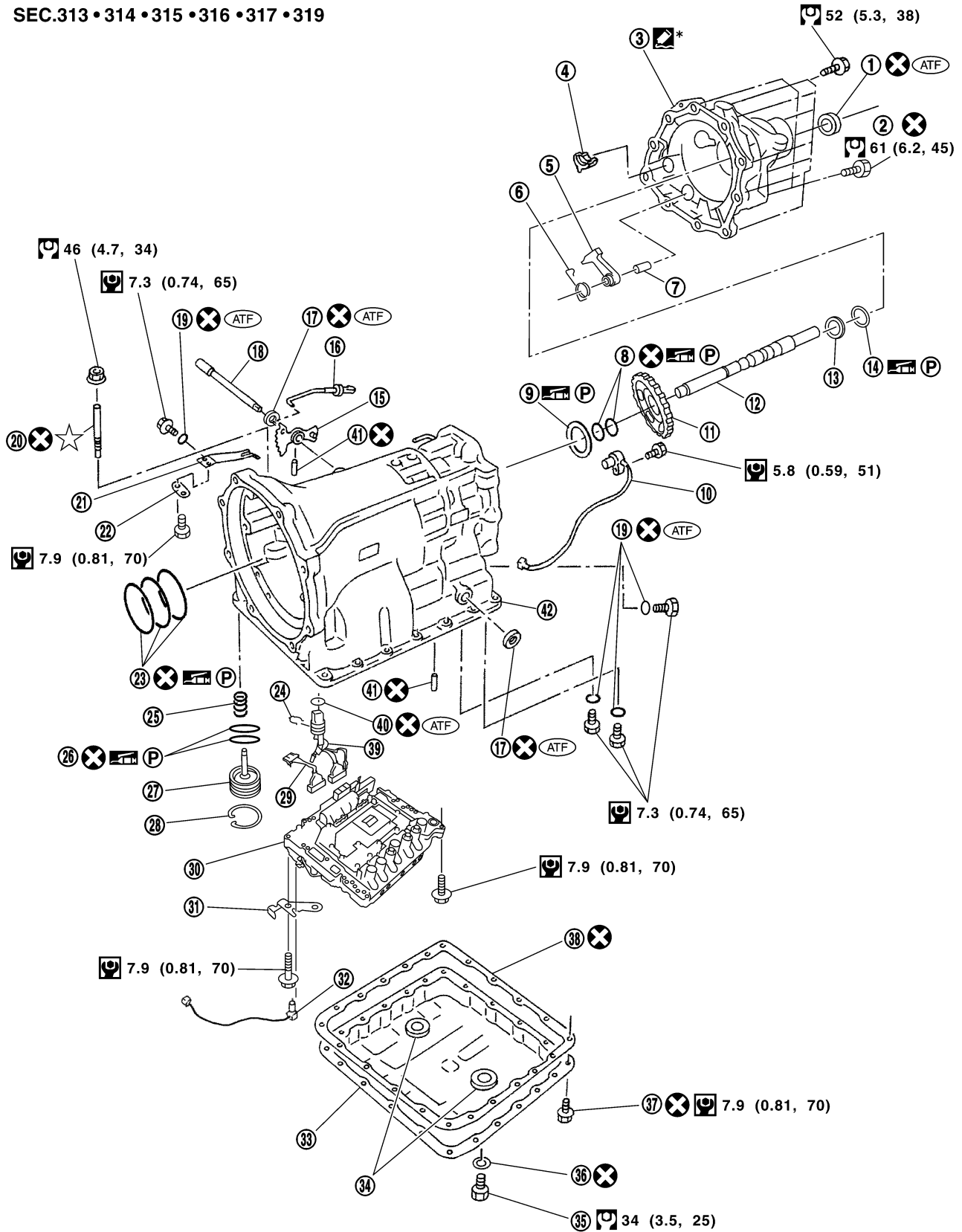

- 1. Rear oil seal
- 4. Parking actuator support

- 2. Self-sealing bolt
- 5. Parking pawl

- 3. Rear extension
- 6. Return spring

SCIA6911E

# OVERHAUL

- 
- |                       |                                    |                            |
|-----------------------|------------------------------------|----------------------------|
| 7. Pawl shaft         | 8. Seal ring                       | 9. Needle bearing          |
| 10. Revolution sensor | 11. Parking gear                   | 12. Output shaft           |
| 13. Bearing race      | 14. Needle bearing                 | 15. Manual plate           |
| 16. Parking rod       | 17. Manual shaft oil seal          | 18. Manual shaft           |
| 19. O-ring            | 20. Band servo anchor end pin      | 21. Detent spring          |
| 22. Spacer            | 23. Seal ring                      | 24. Snap ring              |
| 25. Return spring     | 26. O-ring                         | 27. Servo assembly         |
| 28. Snap ring         | 29. Sub-harness                    | 30. Control valve with TCM |
| 31. Bracket           | 32. A/T fluid temperature sensor 2 | 33. Oil pan                |
| 34. Magnet            | 35. Drain plug                     | 36. Drain plug gasket      |
| 37. Oil pan bolt      | 38. Oil pan gasket                 | 39. Terminal cord assembly |
| 40. O-ring            | 41. Retaining pin                  | 42. Transmission case      |

\*: Apply Genuine Anaerobic Liquid Gasket or equivalent. Refer to [GL-47, "Recommended Chemical Products and Sealants"](#).

A  
B  
AT  
D  
E  
F  
G  
H  
I  
J  
K  
L  
M

# OVERHAUL

## 4WD Models

SEC.313 · 314 · 315 · 316 · 317 · 319

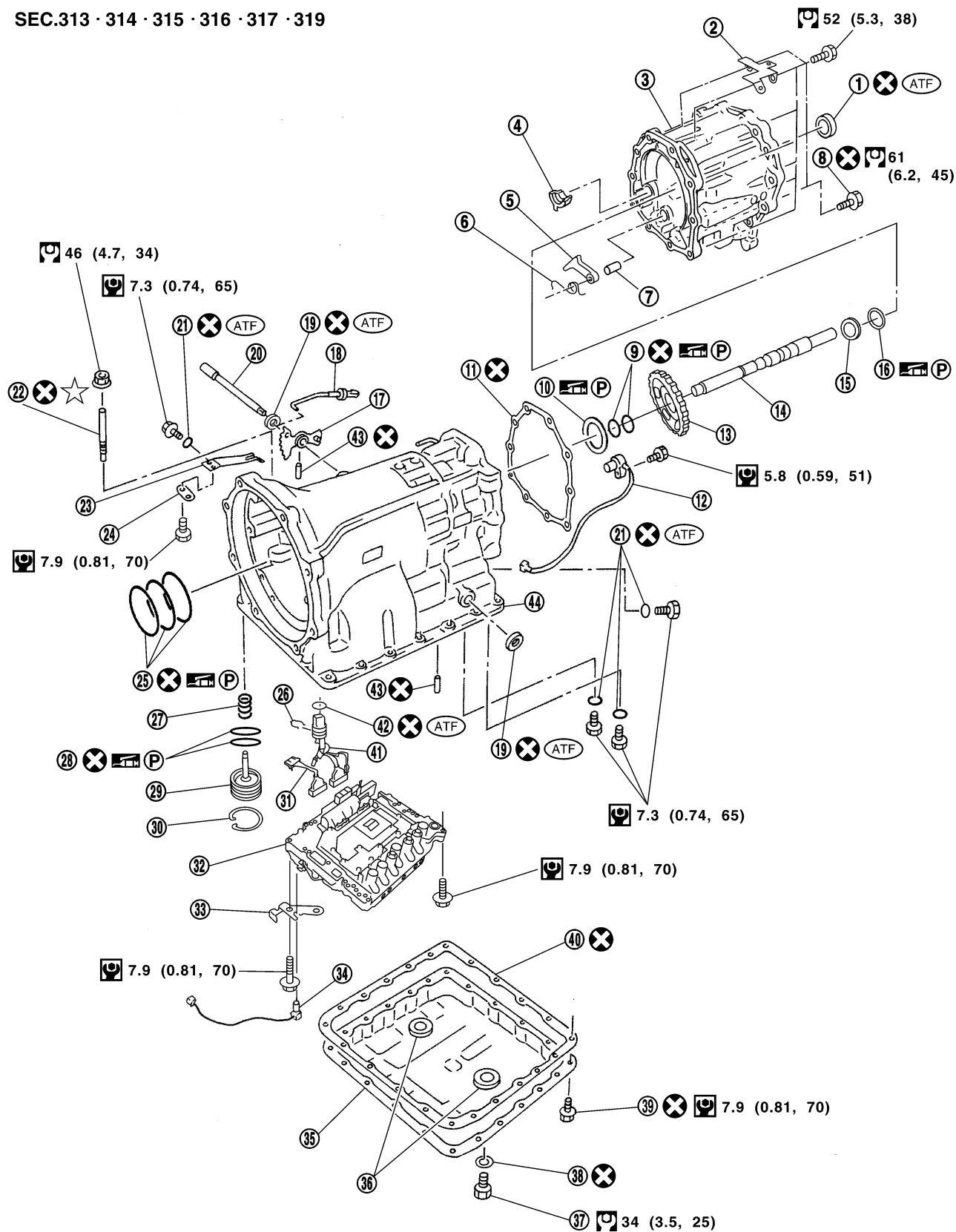

- 1. Rear oil seal
- 4. Parking actuator support

- 2. Bracket
- 5. Parking pawl

- 3. Adapter case
- 6. Return spring

SCIA7218E

# OVERHAUL

- 
- |                                    |                            |                       |
|------------------------------------|----------------------------|-----------------------|
| 7. Pawl shaft                      | 8. Self-sealing bolt       | 9. Seal ring          |
| 10. Needle bearing                 | 11. Gasket                 | 12. Revolution sensor |
| 13. Parking gear                   | 14. Output shaft           | 15. Bearing race      |
| 16. Needle bearing                 | 17. Manual plate           | 18. Parking rod       |
| 19. Manual shaft oil seal          | 20. Manual shaft           | 21. O-ring            |
| 22. Band servo anchor end pin      | 23. Detent spring          | 24. Spacer            |
| 25. Seal ring                      | 26. Snap ring              | 27. Return spring     |
| 28. O-ring                         | 29. Servo assembly         | 30. Snap ring         |
| 31. Sub-harness                    | 32. Control valve with TCM | 33. Bracket           |
| 34. A/T fluid temperature sensor 2 | 35. Oil pan                | 36. Magnet            |
| 37. Drain plug                     | 38. Drain plug gasket      | 39. Oil pan bolt      |
| 40. Oil pan gasket                 | 41. Terminal cord assembly | 42. O-ring            |
| 43. Retaining pin                  | 44. Transmission case      |                       |

A

B

AT

D

E

F

G

H

I

J

K

L

M

# OVERHAUL

## Oil Channel

UCS00490

### 2WD Models

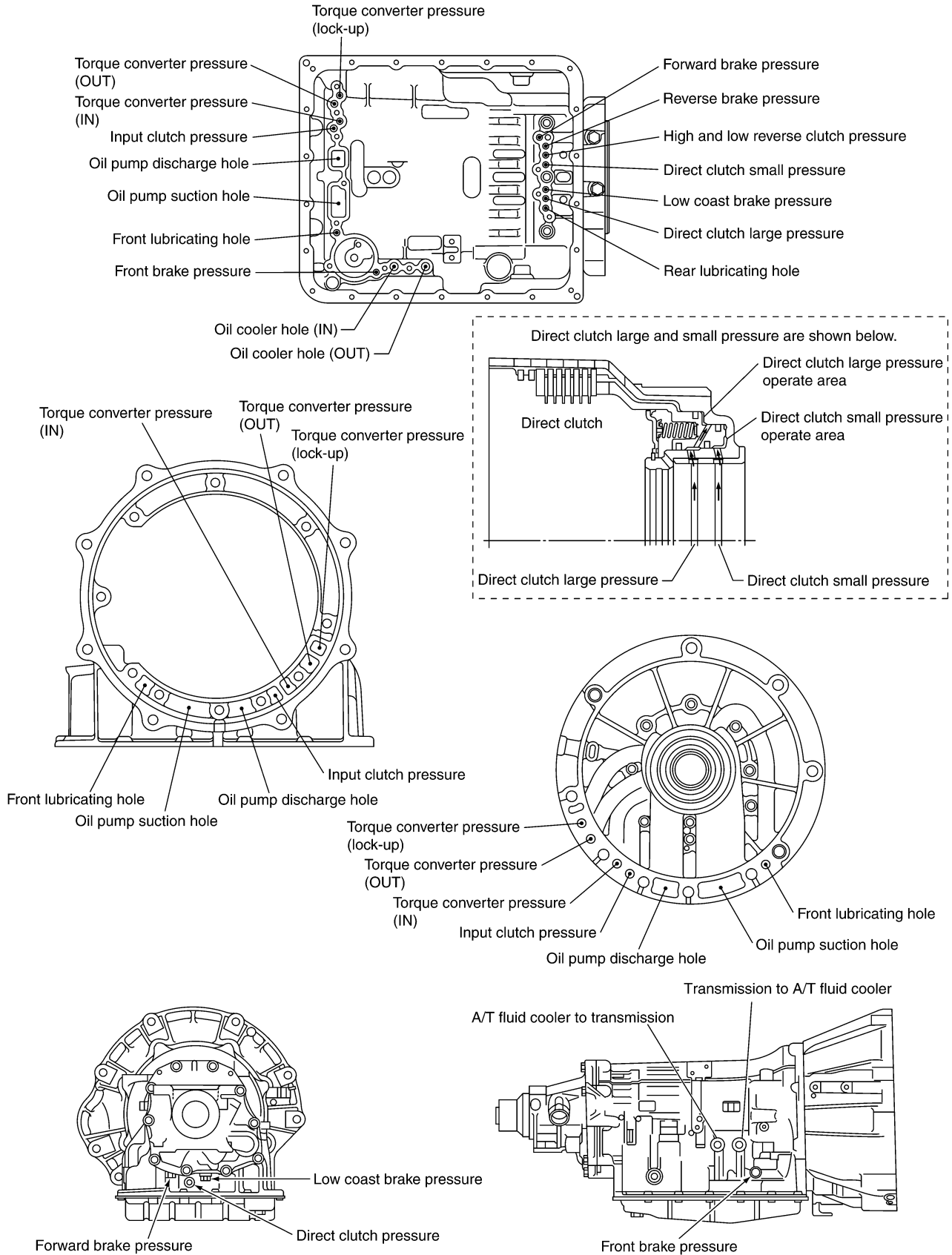

SCIA5185E



# OVERHAUL

## 4WD Models

A  
B  
**AT**  
D  
E  
F  
G  
H  
I  
J  
K  
L  
M

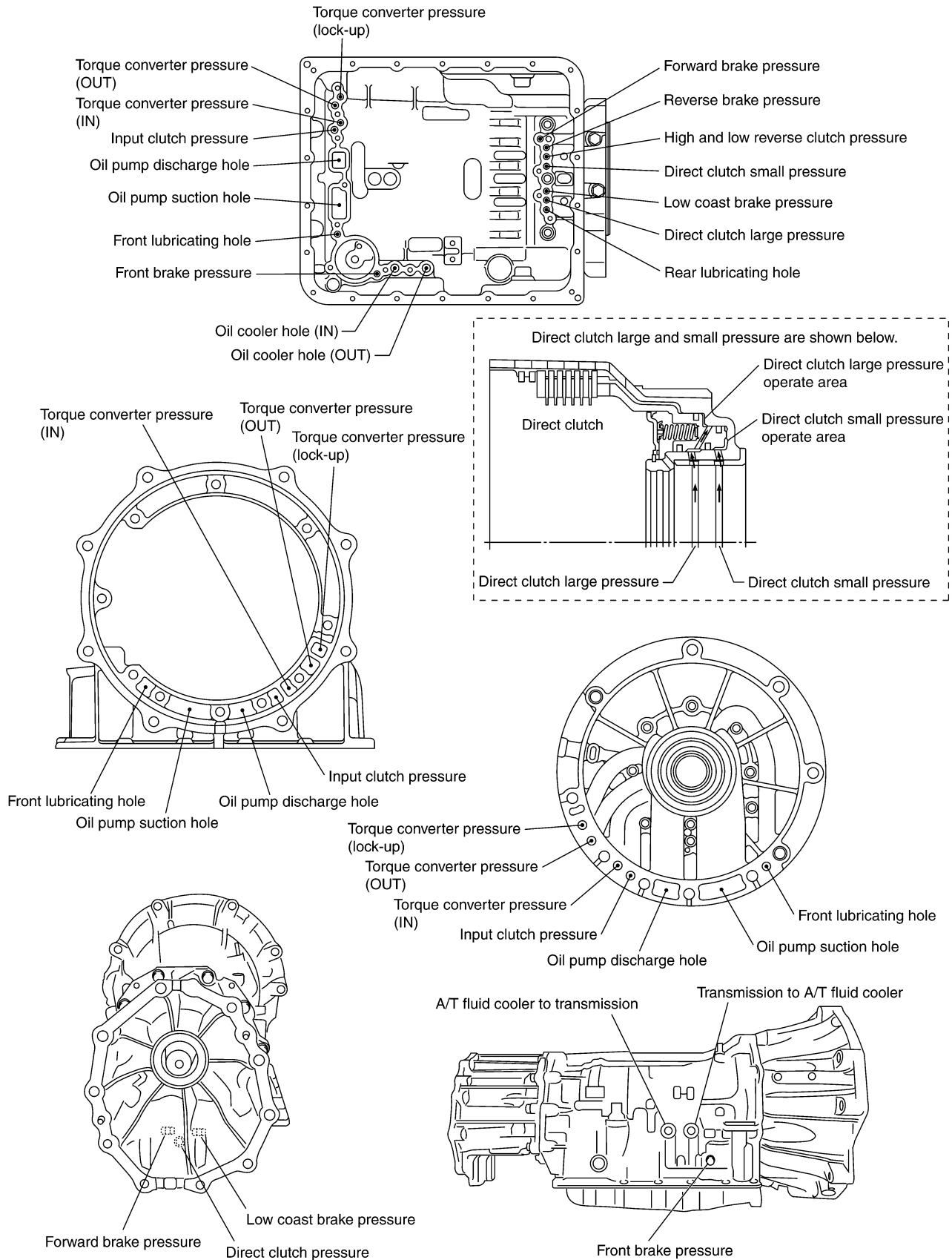

SCIA5189E

# OVERHAUL

## Locations of Adjusting Shims, Needle Bearings, Thrust Washers and Snap Rings

UCS00491

### 2WD Models

Outer diameter of snap rings

Item number	Outer diameter mm (in)
①	63 (2.48)
②	183 (7.20)
③	173 (6.81)
④	70 (2.76)
⑤	170 (6.69)
⑥	135 (5.31)
⑦	180 (7.09)
⑧	185 (7.28)
⑨	48 (1.89)

Outer diameter of needle bearings

Item number	Outer diameter mm (in)
⑩	80 (3.15)
⑪	77 (3.03)
⑫	77 (3.03)
⑬	47 (1.85)
⑭	84 (3.31)
⑮	80 (3.15)
⑯	92 (3.62)
⑰	60 (2.36)
⑱	63 (2.48)
⑲	92 (3.62)
⑳	65 (2.56)
㉑	60 (2.36)

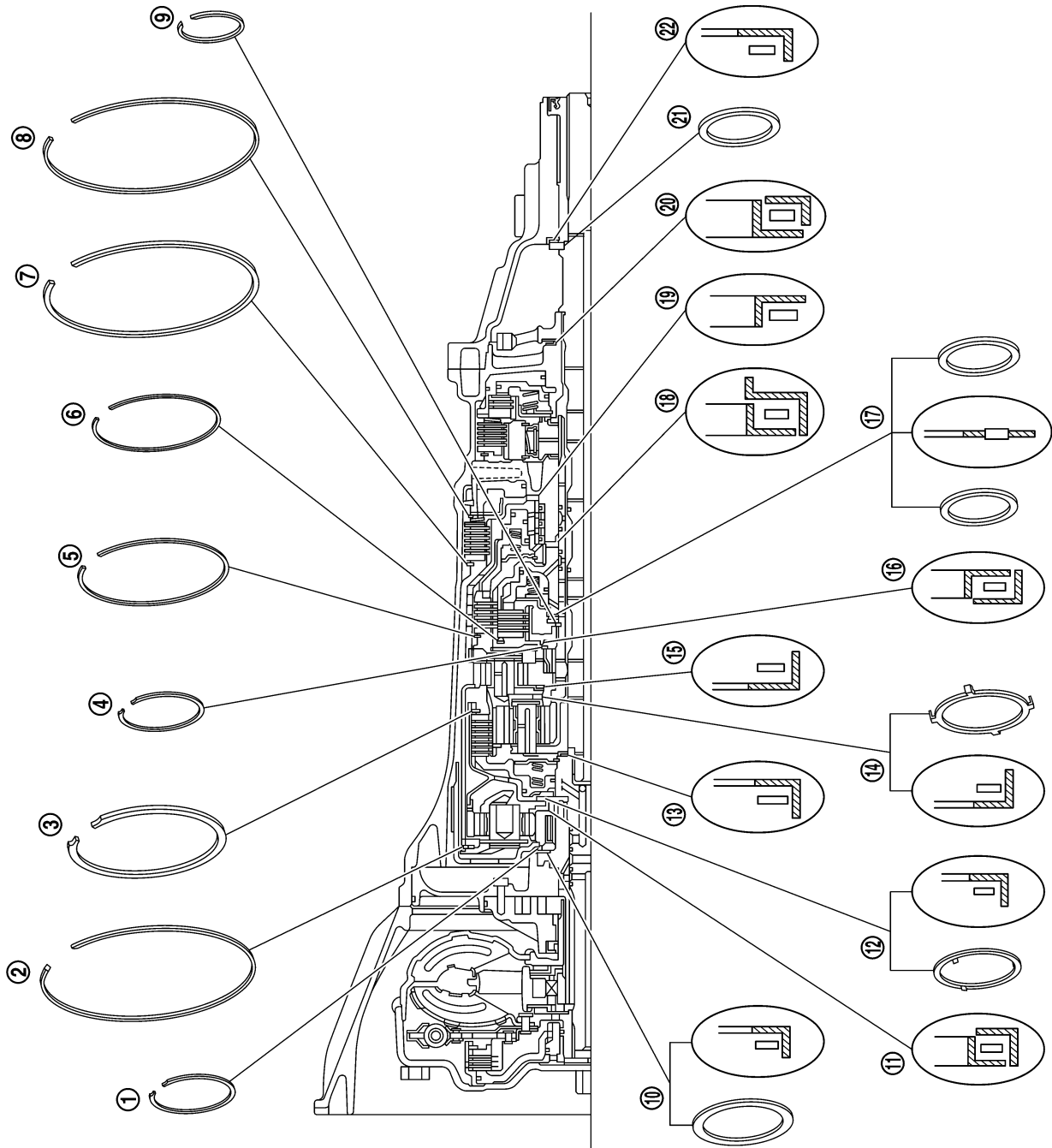

# OVERHAUL

## 4WD Models

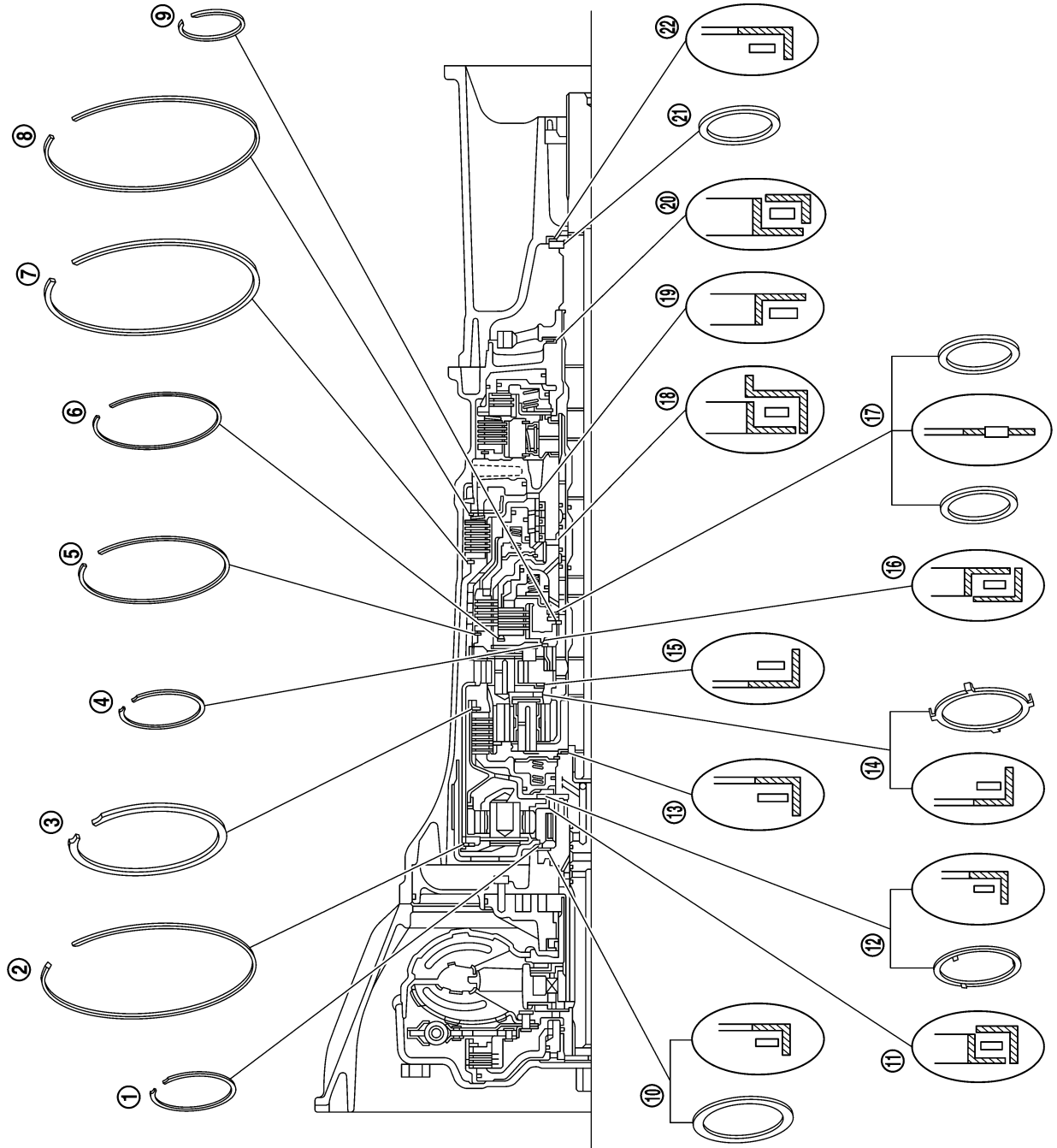

Outer diameter of snap rings

Item number	Outer diameter mm (in)
1	63 (2.48)
2	183 (7.20)
3	173 (6.81)
4	70 (2.76)
5	170 (6.69)
6	135 (5.31)
7	180 (7.09)
8	185 (7.28)
9	48 (1.89)

Outer diameter of needle bearings

Item number	Outer diameter mm (in)
10	80 (3.15)
11	77 (3.03)
12	77 (3.03)
13	47 (1.85)
14	84 (3.31)
15	80 (3.15)
16	92 (3.62)
17	60 (2.36)
18	63 (2.48)
19	92 (3.62)
20	65 (2.56)
22	60 (2.36)

A  
B  
**AT**  
D  
E  
F  
G  
H  
I  
J  
K  
L  
M

SCIA7020E

## DISASSEMBLY

### Disassembly

**CAUTION:**

Do not disassemble parts behind drum support. Refer to [AT-18, "Cross-Sectional View"](#) .

1. Drain ATF through drain plug.
2. Remove torque converter by holding it firmly and turing while pulling straight out.

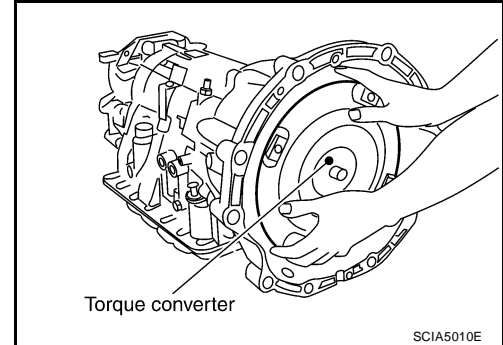

3. Check torque converter one-way clutch using a check tool as shown.
  - a. Insert a check tool into the groove of bearing support built into one-way clutch outer race.
  - b. While holding bearing support with a check tool, rotate one-way clutch spline using a suitable tool.
  - c. Make sure that inner race rotates clockwise only. If not, replace torque converter assembly.

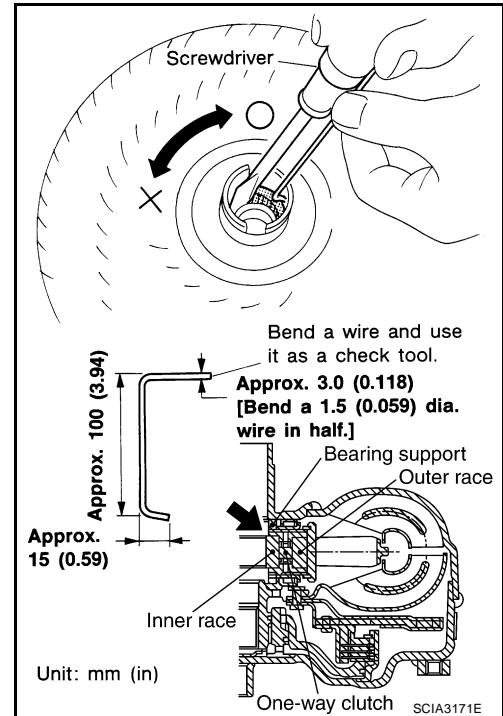

4. Remove bolts and converter housing from transmission case.

**CAUTION:**

Do not scratch converter housing.

- Self-sealing bolt (A)

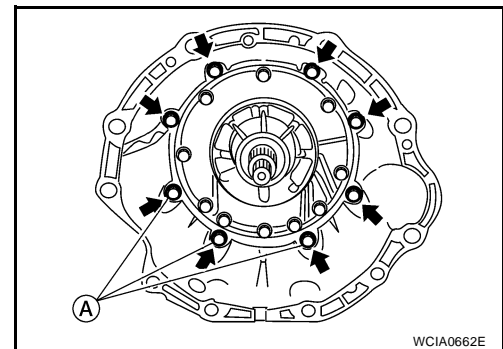

# DISASSEMBLY

5. Remove O-ring from input clutch assembly.

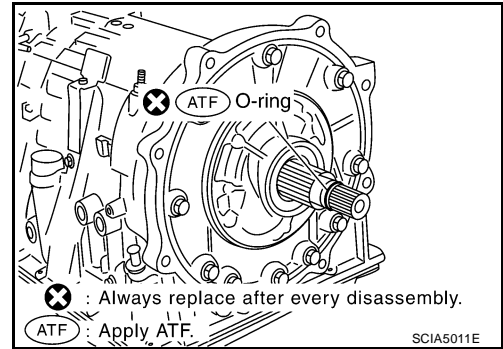

6. Remove bolts for oil pump assembly and transmission case.

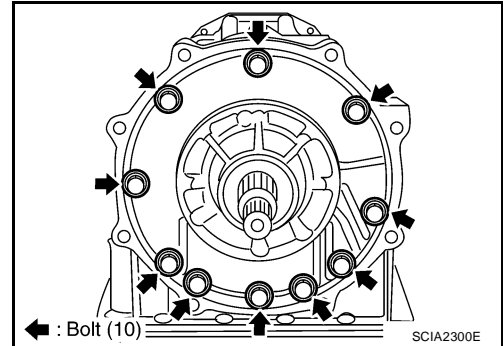

7. Attach the Tool to oil pump assembly and extract it evenly from transmission case.

**Tool number** : ST25850000 (J-25721-A)

**CAUTION:**

- Fully tighten the sliding hammer screws.
- Make sure that bearing race is installed to the oil pump assembly edge surface.

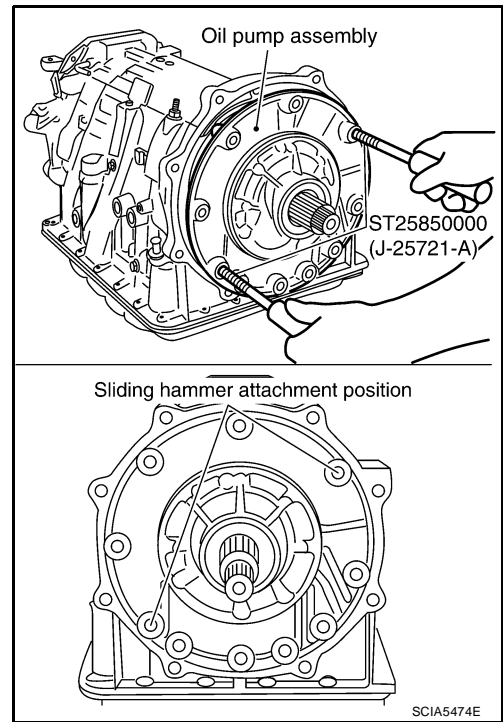

8. Remove O-ring from oil pump assembly.

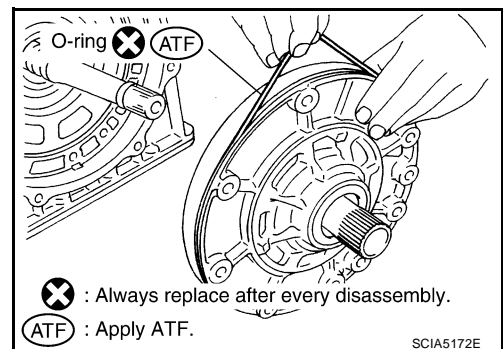

A  
B  
AT  
D  
E  
F  
G  
H  
I  
J  
K  
L  
M

# DISASSEMBLY

9. Remove bearing race from oil pump assembly.

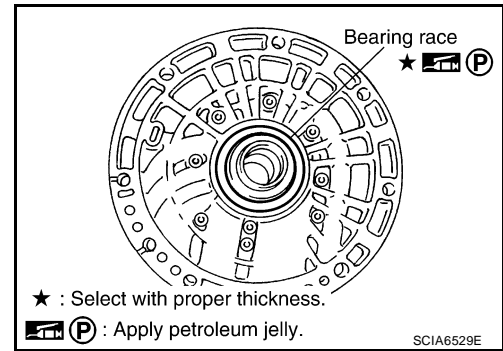

10. Remove needle bearing from front sun gear.

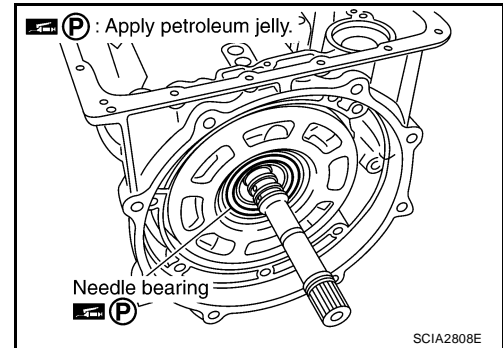

11. Remove front sun gear assembly from front carrier assembly.

**NOTE:**  
Remove front sun gear by rotating left/right.

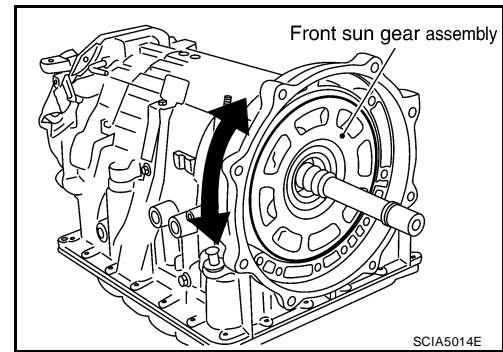

12. Remove seal rings from input clutch assembly.

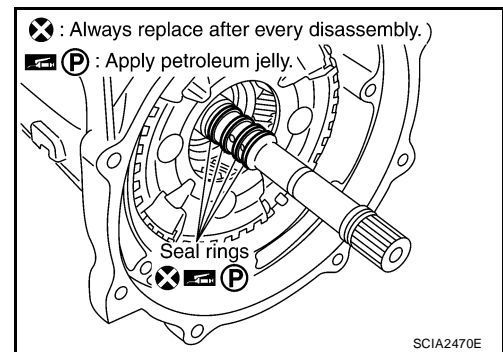

13. Remove front carrier assembly from rear carrier assembly (with input clutch assembly and rear internal gear).

**CAUTION:**  
Be careful to remove it with needle bearing.

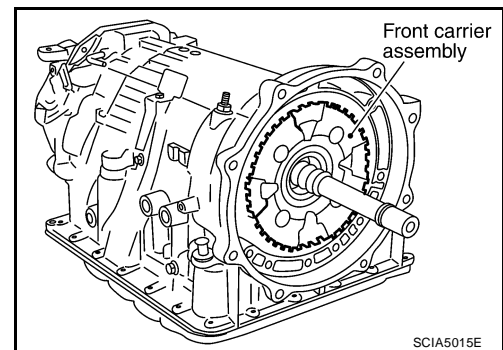

# DISASSEMBLY

14. Loosen lock nut and remove band servo anchor end pin from transmission case.

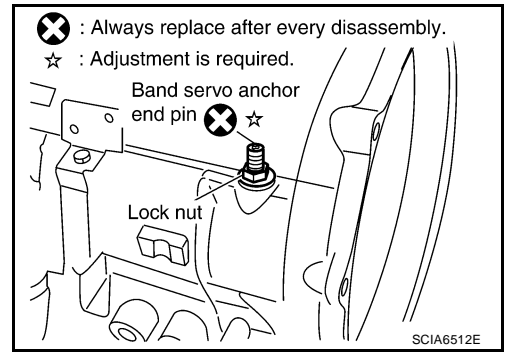

15. Remove brake band from transmission case.

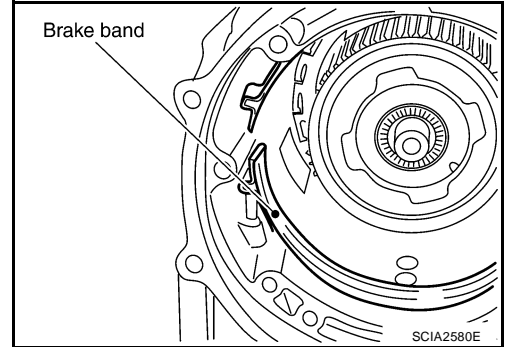

- To prevent brake linings from cracking or peeling, do not stretch the flexible band unnecessarily. When removing the brake band, always secure it with a clip as shown. Leave the clip in position after removing the brake band.
- Check brake band facing for damage, cracks, wear or burns.

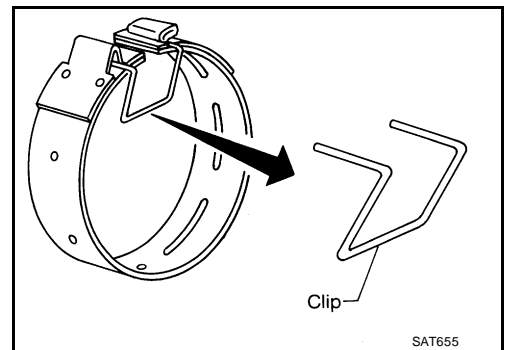

16. Remove mid carrier assembly and rear carrier assembly as a unit.

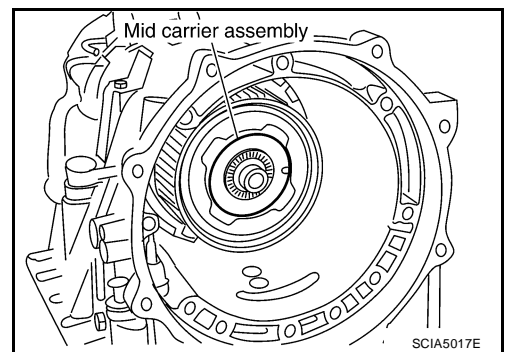

17. Remove mid carrier assembly from rear carrier assembly.

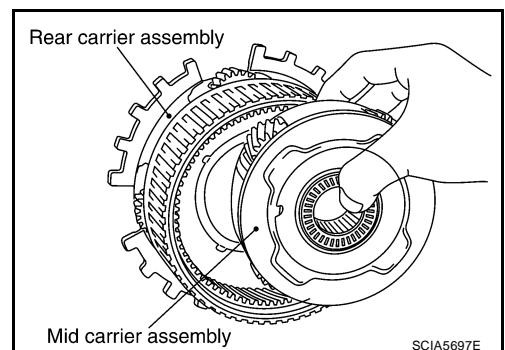

A  
B  
AT  
D  
E  
F  
G  
H  
I  
J  
K  
L  
M

# DISASSEMBLY

18. Remove needle bearing (front side) from mid carrier assembly.

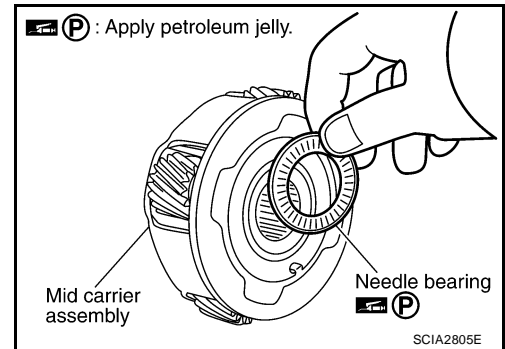

19. Remove needle bearing (rear side) from mid carrier assembly.

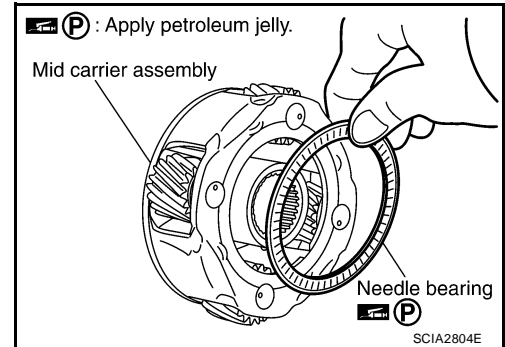

20. Remove bearing race from rear carrier assembly.

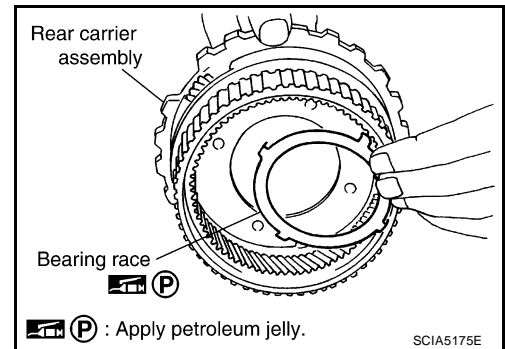

21. Remove needle bearing from rear carrier assembly.

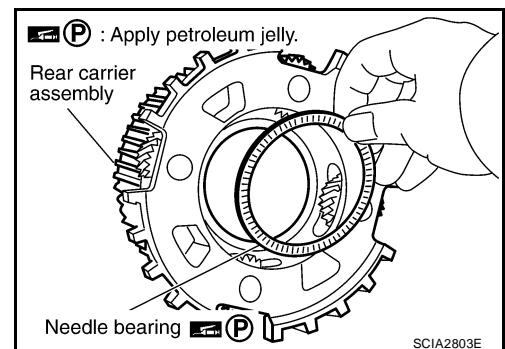

22. Remove mid sun gear assembly, rear sun gear assembly and high and low reverse clutch hub as a unit.

**CAUTION:**

**Be careful to remove them with bearing race and needle bearing.**

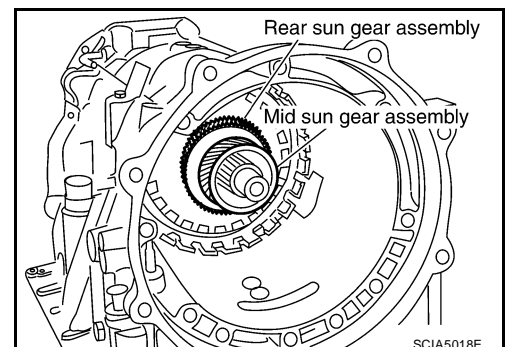



# DISASSEMBLY

23. Remove high and low reverse clutch assembly from direct clutch assembly.

**CAUTION:**

Make sure that needle bearing is installed to the high and low reverse clutch assembly edge surface.

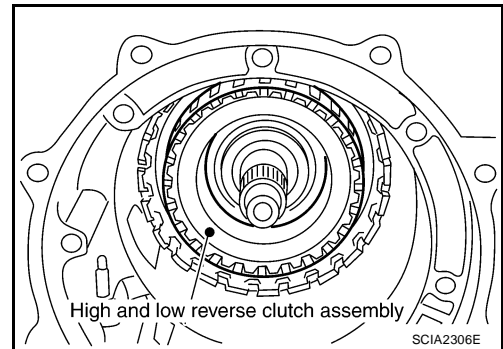

24. Remove needle bearing from drum support.

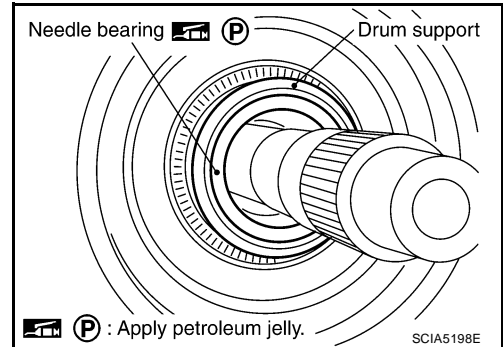

25. Remove direct clutch assembly from reverse brake.

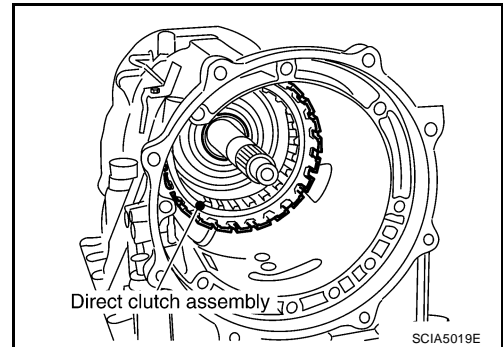

26. Remove snap ring from A/T assembly harness connector.

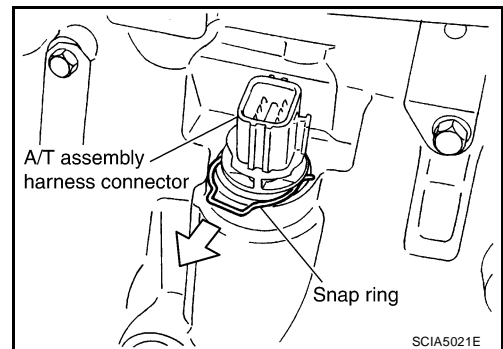

27. Push A/T assembly harness connector.

**CAUTION:**

Do not damage connector.

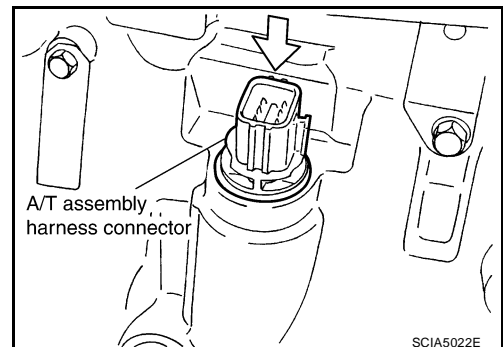

A  
B  
AT  
D  
E  
F  
G  
H  
I  
J  
K  
L  
M

# DISASSEMBLY

28. Remove oil pan and oil pan gasket.

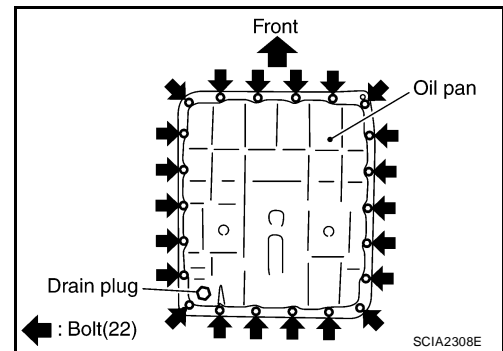

29. Check for foreign materials in oil pan to help determine cause of malfunction. If the A/T fluid is very dark, smells burned, or contains foreign particles, the friction material (clutches, band) may need replacement. A tacky film that will not wipe clean indicates varnish build up. Varnish can cause valves, servo, and clutches to stick and can inhibit pump pressure.

**CAUTION:**

If friction material is detected, flush the transmission cooler after repair. Refer to [AT-15, "A/T Fluid Cooler Cleaning"](#).

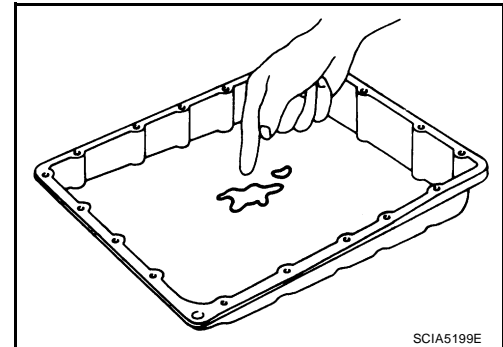

30. Remove magnets from oil pan.

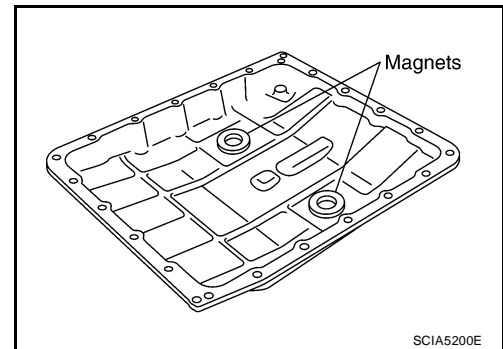

31. Straighten terminal clips to free terminal cord assembly and A/T fluid temperature sensor 2 harness.

32. Disconnect A/T fluid temperature sensor 2 connector.

**CAUTION:**

**Do not damage connector.**

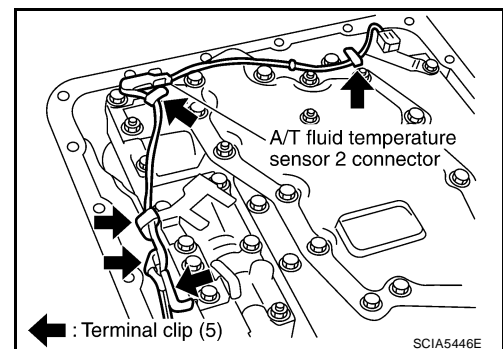

33. Straighten terminal clip to free revolution sensor harness.

34. Disconnect revolution sensor connector.

**CAUTION:**

**Do not damage connector.**

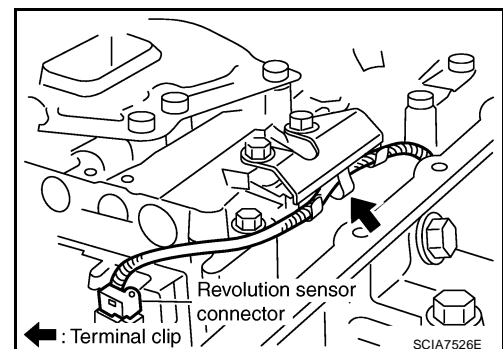

# DISASSEMBLY

35. Remove bolts A, B and C from control valve with TCM.

Bolt symbol	Length mm (in)	Number of bolts
A	42 (1.65)	5
B	55 (2.17)	6
C	40 (1.57)	1

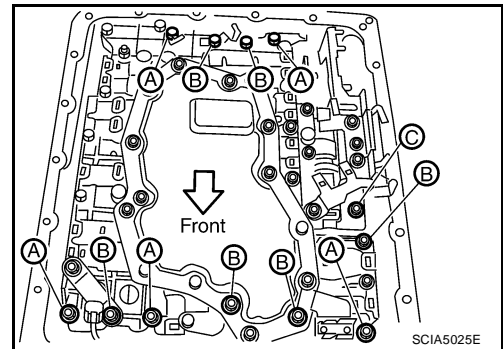

36. Remove control valve with TCM from transmission case.

**CAUTION:**

When removing, be careful with the manual valve notch and manual plate height. Remove it vertically.

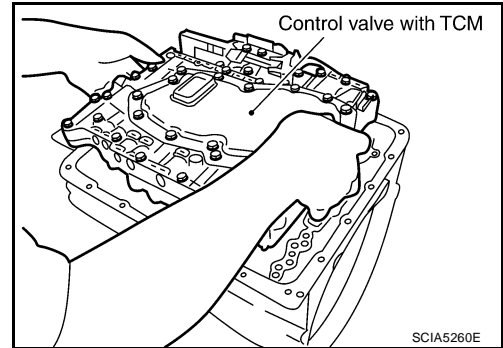

37. Remove A/T fluid temperature sensor 2 with bracket from control valve with TCM.

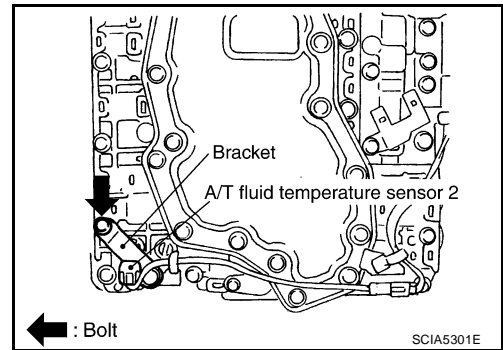

38. Remove bracket from A/T fluid temperature sensor 2.

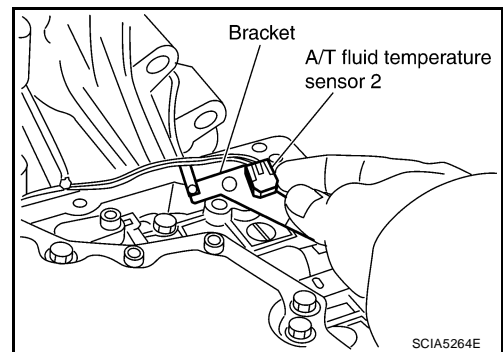

39. Remove O-ring from A/T assembly harness connector.

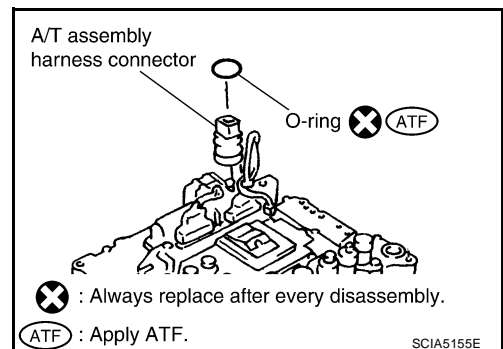

A  
B  
AT  
D  
E  
F  
G  
H  
I  
J  
K  
L  
M

# DISASSEMBLY

40. Disconnect TCM connectors.

**CAUTION:**  
Do not damage connectors.

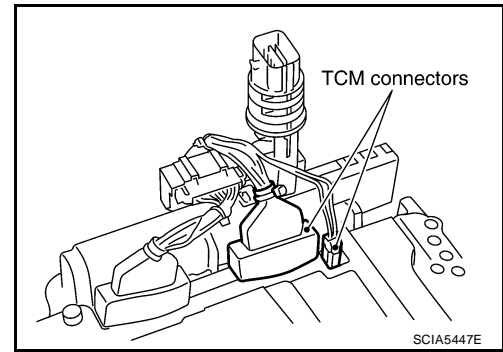

41. Remove A/T assembly harness connector from control valve with TCM using suitable tool.

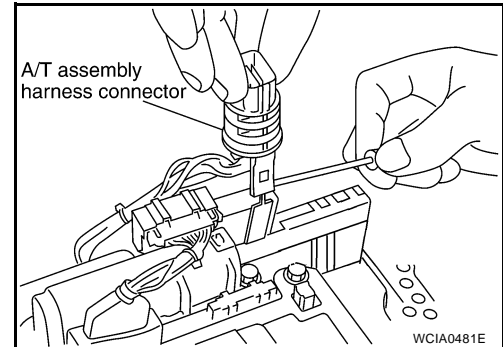

42. Disconnect TCM connector and park/neutral position switch connector.

**CAUTION:**  
Do not damage connectors.

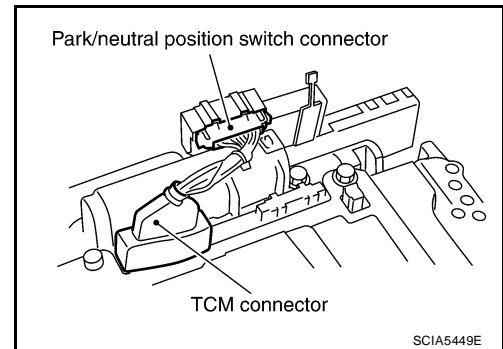

43. Remove rear extension assembly (2WD models) or adapter case assembly (4WD models) according to the following procedures.

a. **2WD models**

i. Remove bolts for rear extension assembly and transmission case.

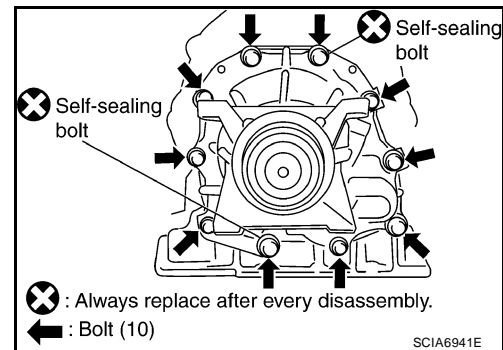

# DISASSEMBLY

ii. Tap rear extension assembly using suitable tool.

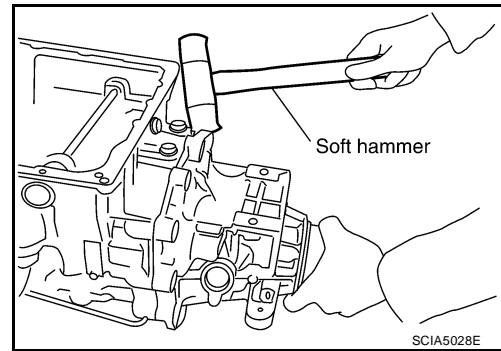

iii. Remove rear extension assembly from transmission case (with needle bearing).

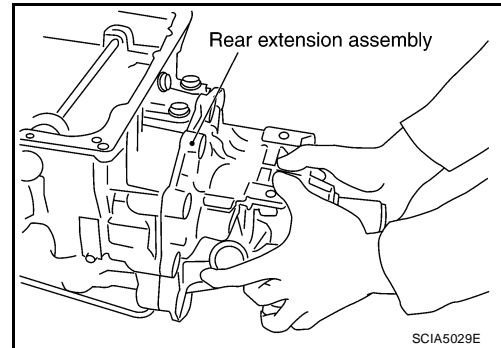

## b. 4WD models

i. Remove bolts (1) for adapter case assembly and transmission case [with terminal bracket (2)].

- Self-sealing bolt (3)

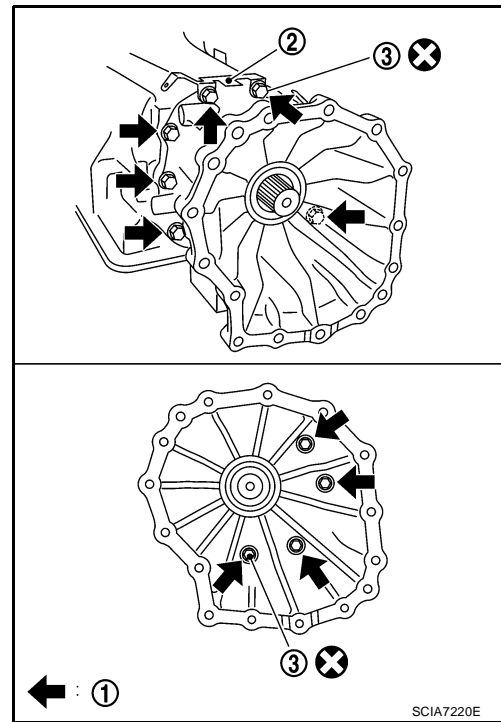

ii. Tap adapter case assembly using suitable tool.

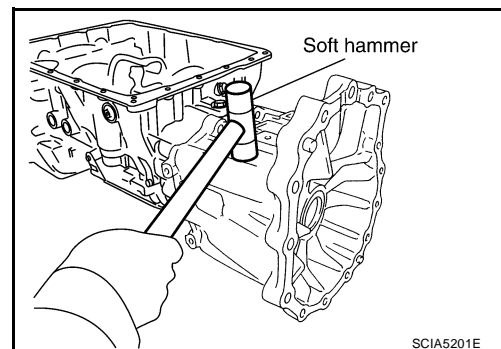

A  
B  
AT  
D  
E  
F  
G  
H  
I  
J  
K  
L  
M

# DISASSEMBLY

- iii. Remove adapter case assembly from transmission case (with needle bearing).

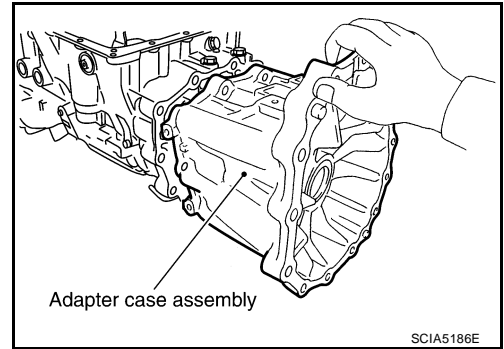

- iv. Remove gasket from transmission case.

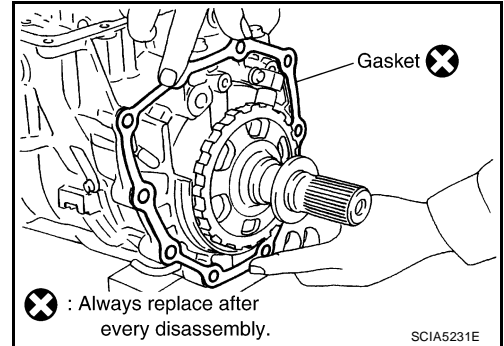

- 44. Remove bearing race from output shaft.

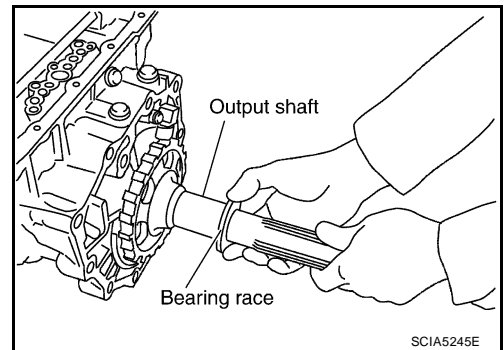

- 45. Remove output shaft from transmission case by rotating left/right.

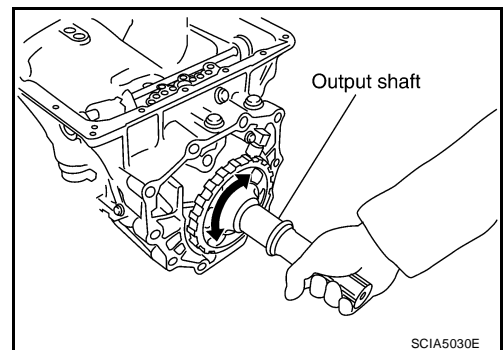

- 46. Remove parking gear from output shaft.

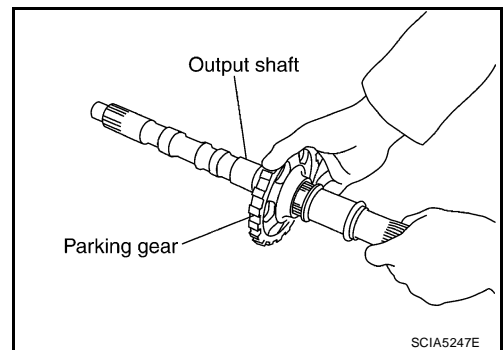

# DISASSEMBLY

47. Remove seal rings from output shaft.

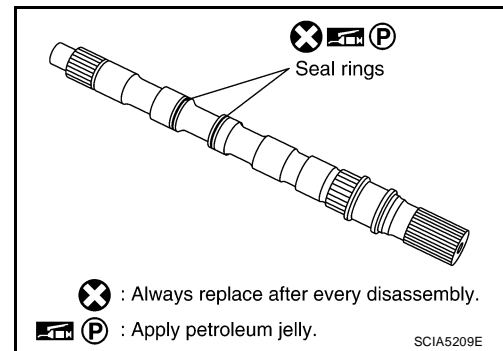

48. Remove needle bearing from transmission case.

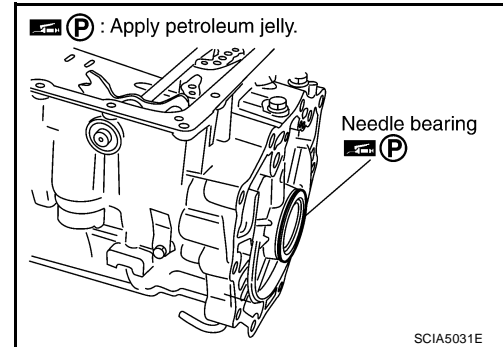

49. Remove revolution sensor from transmission case.

**CAUTION:**

- Do not subject it to impact by dropping or hitting it.
- Do not disassemble.
- Do not allow metal filings or debris to get on the sensor's front edge magnetic area.
- Do not place in an area affected by magnetism.

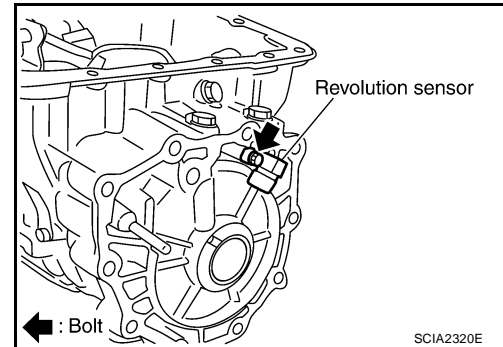

50. Remove reverse brake snap ring using suitable tools.

**NOTE:**

Press out snap ring from the transmission case oil pan side gap using a suitable tool, and remove it using another suitable tool.

51. Remove reverse brake retaining plate from transmission case.

- Check facing for burns, cracks or damage. If necessary, replace the plate.

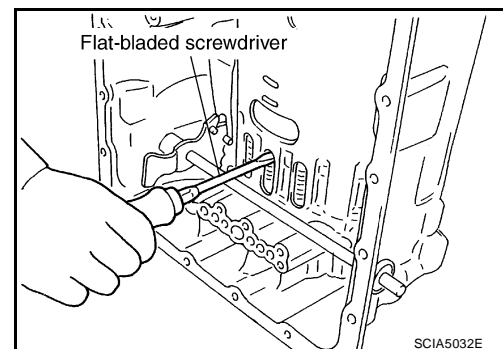

52. Remove N-spring from transmission case.

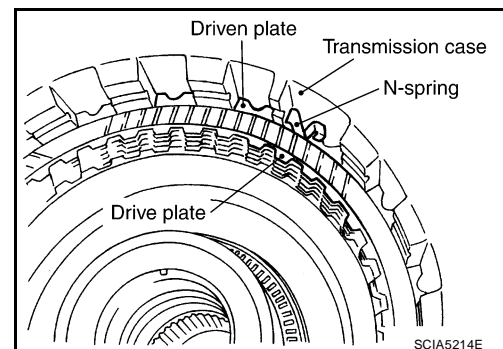

A  
B  
AT  
D  
E  
F  
G  
H  
I  
J  
K  
L  
M

## DISASSEMBLY

53. Remove reverse brake drive plates, driven plates and dish plate from transmission case.

- Check facing for burns, cracks or damage. If necessary, replace the plate.

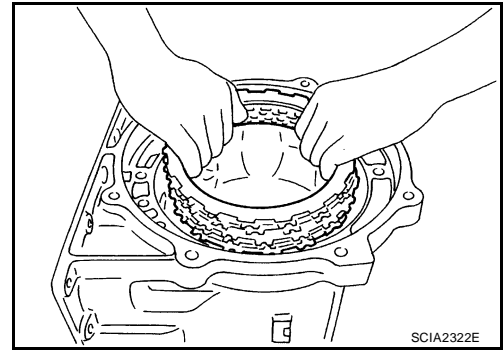

54. Remove snap ring (spring retainer) using suitable tool.

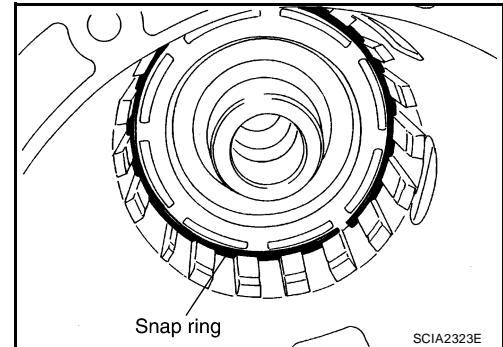

55. Remove spring retainer and return spring from transmission case.

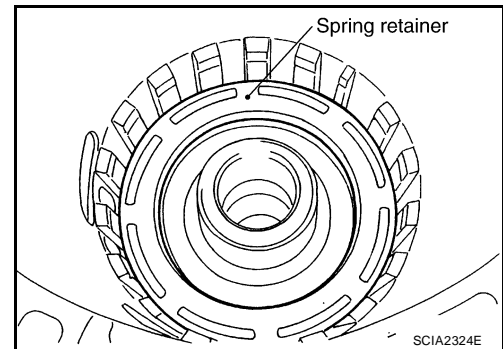

56. Remove seal rings from drum support.

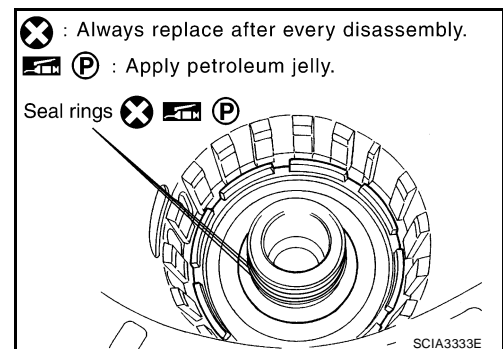

57. Remove needle bearing from drum support edge surface.

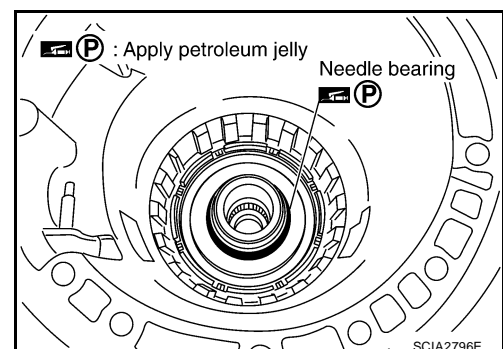



# DISASSEMBLY

58. Remove reverse brake piston from transmission case with compressed air. Refer to [AT-264, "Oil Channel"](#) .

**CAUTION:**

Care should be taken not to abruptly blow air. It makes pistons incline, as the result, it becomes hard to disassemble the pistons.

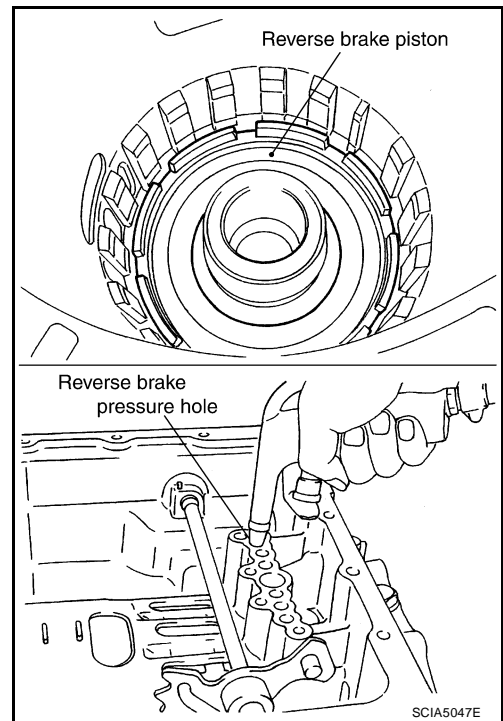

59. Remove D-rings from reverse brake piston.

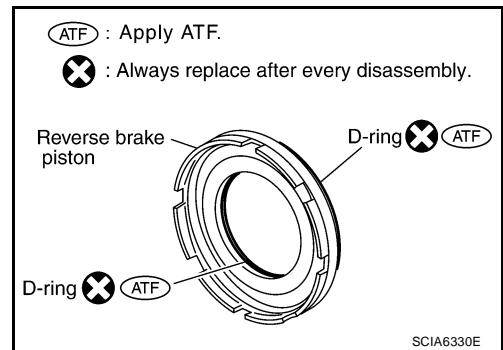

60. Knock out retaining pin using suitable tool.

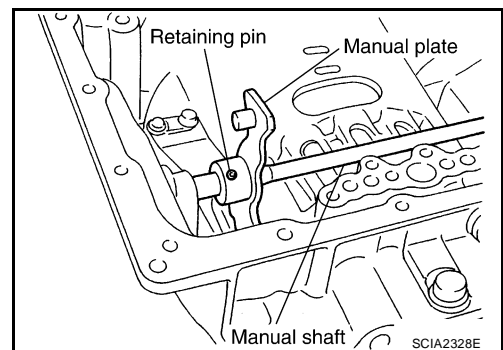

61. Remove manual shaft retaining pin using suitable tool.

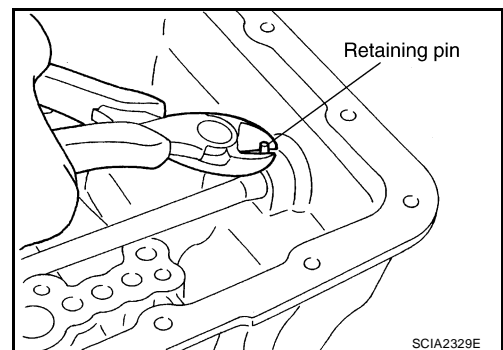

A  
B  
AT  
D  
E  
F  
G  
H  
I  
J  
K  
L  
M

# DISASSEMBLY

62. Remove manual plate (with parking rod) from manual shaft.

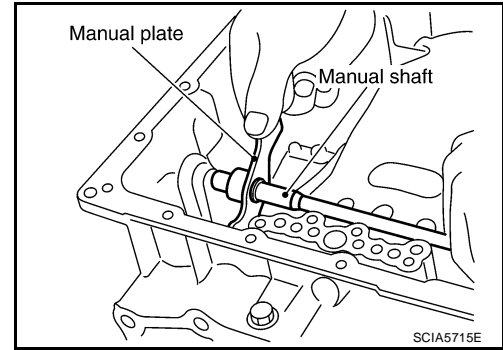

63. Remove parking rod from manual plate.

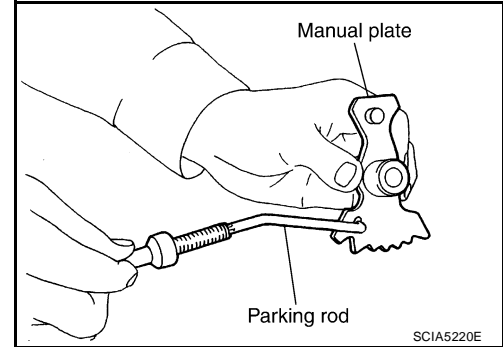

64. Remove manual shaft from transmission case.

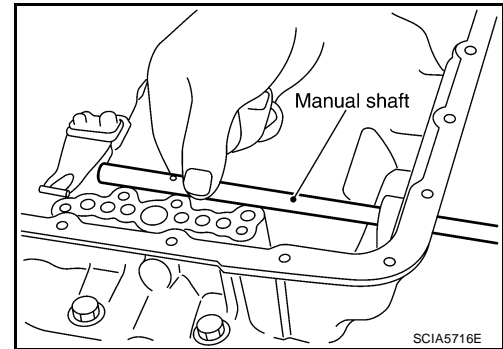

65. Remove manual shaft oil seals using suitable tool.

**CAUTION:**  
Do not scratch transmission case.

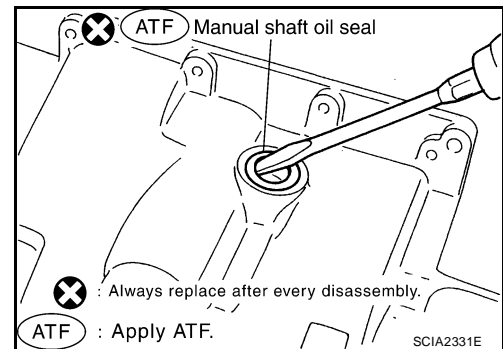

66. Remove detent spring and spacer from transmission case.

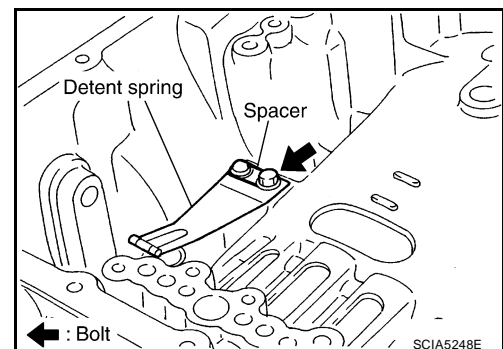

# DISASSEMBLY

67. Remove snap ring from transmission case using suitable tool.

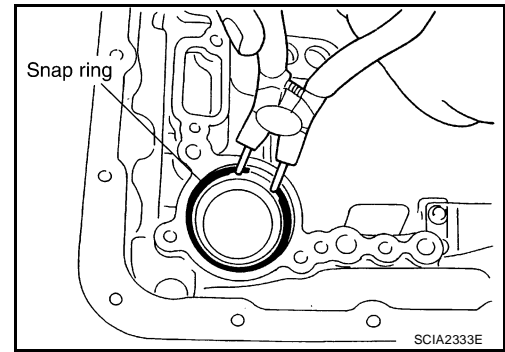

68. Remove servo assembly (with return spring) from transmission case.

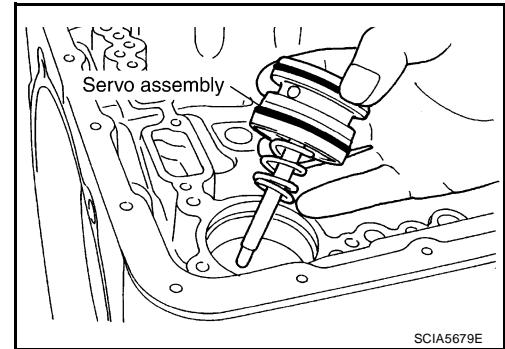

69. Remove return spring from servo assembly.

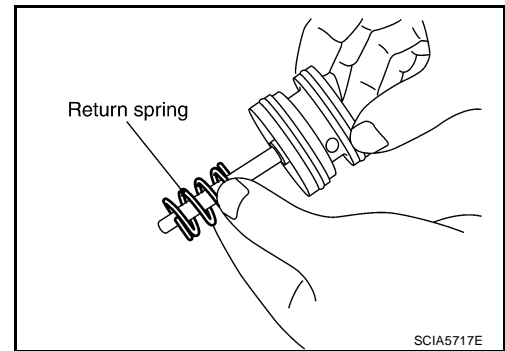

70. Remove O-rings from servo assembly.

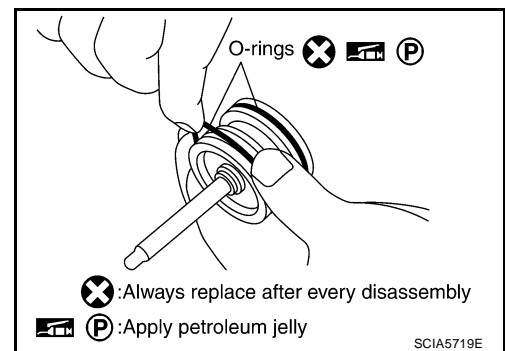

71. Remove needle bearing (1) from rear extension (2WD models) or adapter case (4WD models).

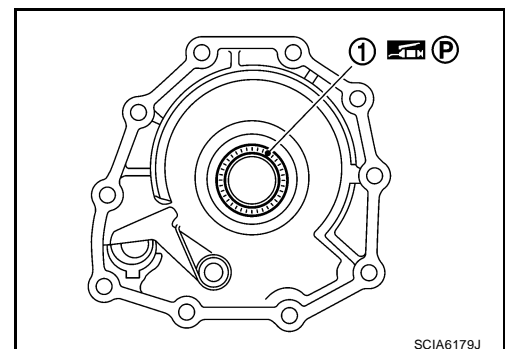

A  
B  
AT  
D  
E  
F  
G  
H  
I  
J  
K  
L  
M

# DISASSEMBLY

72. Remove parking actuator support from rear extension (2WD models) or adapter case (4WD models).

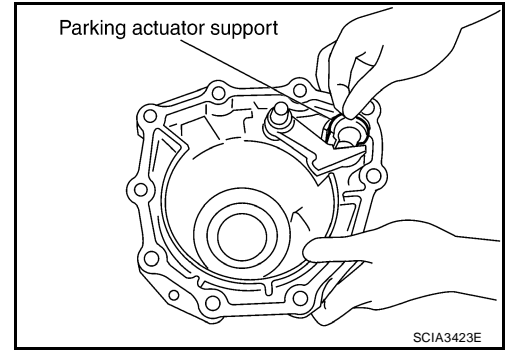

73. Remove parking pawl (with return spring) and pawl shaft from rear extension (2WD models) or adapter case (4WD models).

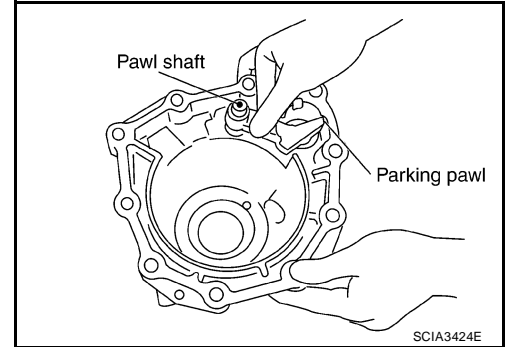

74. Remove return spring (1) from parking pawl (2).

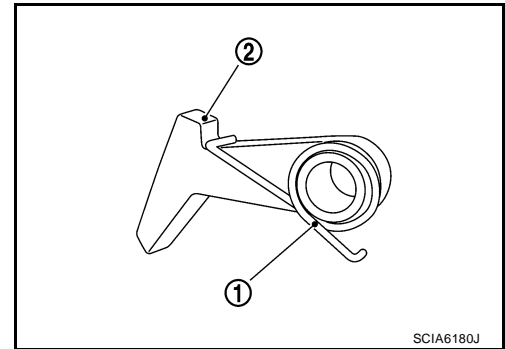

75. Remove rear oil seal from rear extension (2WD models) or adapter case (4WD models).

**CAUTION:**

**Do not scratch rear extension (2WD models) or adapter case (4WD models).**

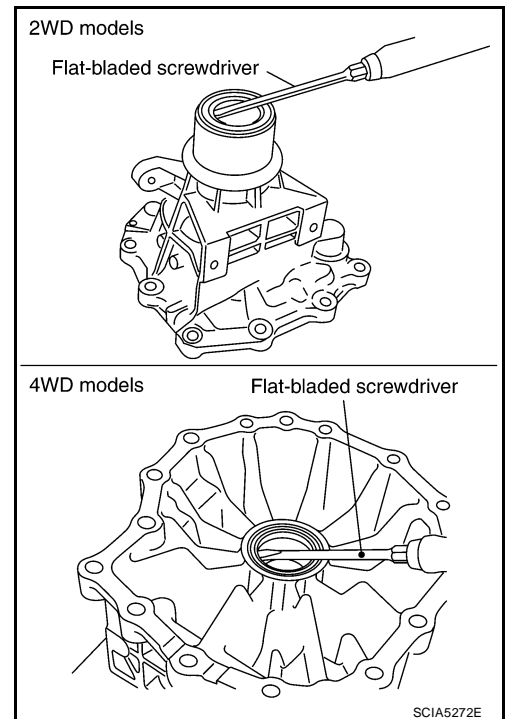

# REPAIR FOR COMPONENT PARTS

## REPAIR FOR COMPONENT PARTS

PFP:00000

### Oil Pump COMPONENTS

UCS00493

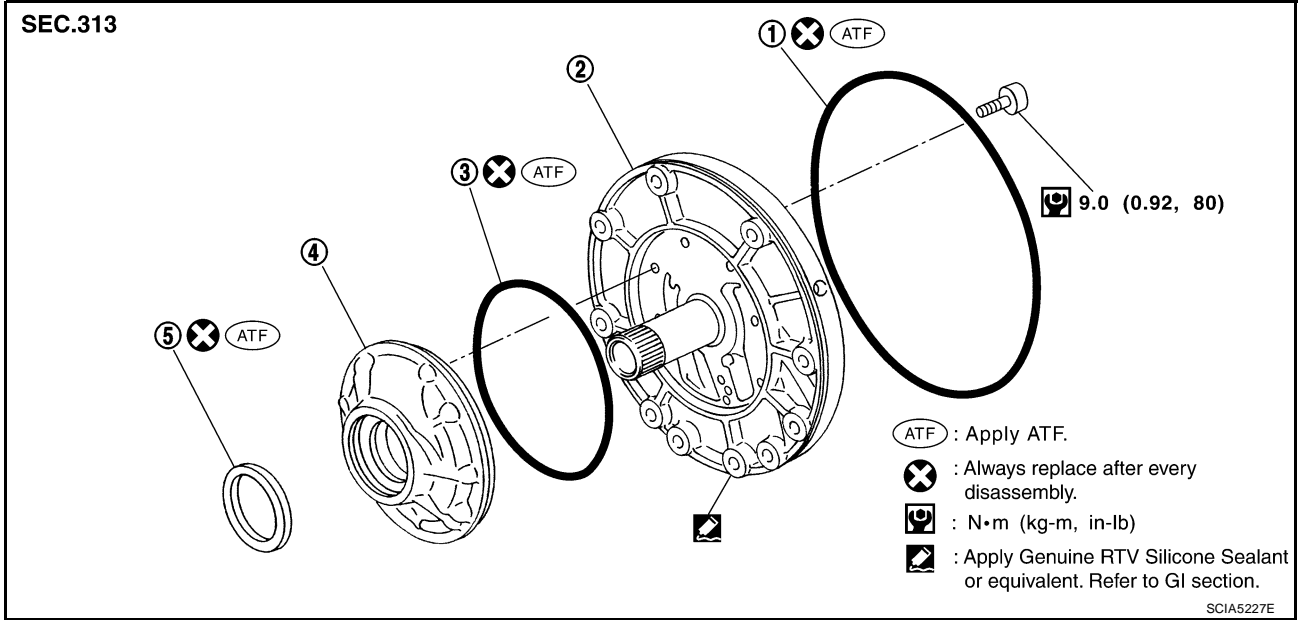

1. O-ring
2. Oil pump cover
3. O-ring
4. Oil pump housing
5. Oil pump housing oil seal

### DISASSEMBLY

1. Remove oil pump housing from oil pump cover.

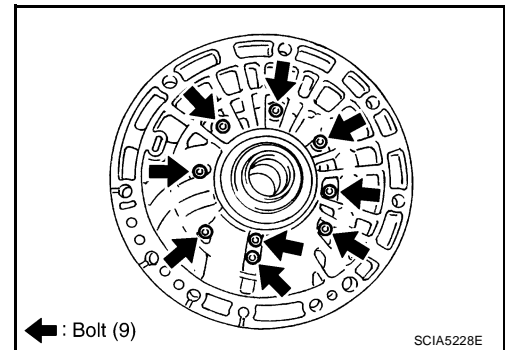

2. Remove oil pump housing oil seal using suitable tool.

**CAUTION:**  
Do not scratch oil pump housing.

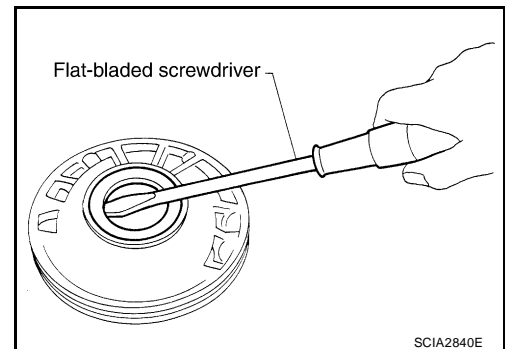

## REPAIR FOR COMPONENT PARTS

3. Remove O-ring from oil pump housing.

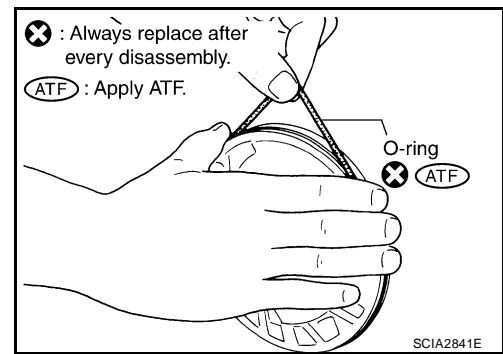

4. Remove O-ring from oil pump cover.

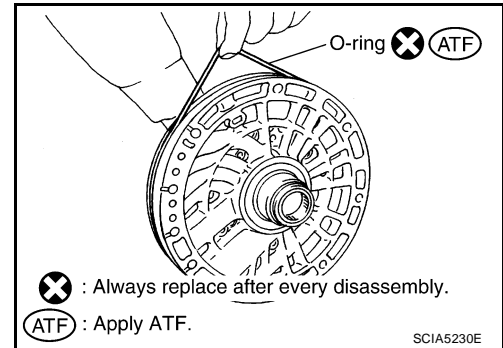

### ASSEMBLY

1. Install O-ring to oil pump cover.

**CAUTION:**

- Do not reuse O-ring.
- Apply ATF to O-ring.

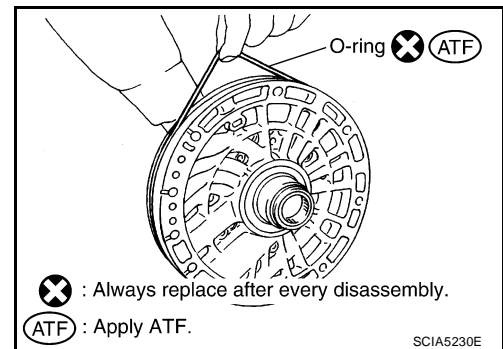

2. Install O-ring to oil pump housing.

**CAUTION:**

- Do not reuse O-ring.
- Apply ATF to O-ring.

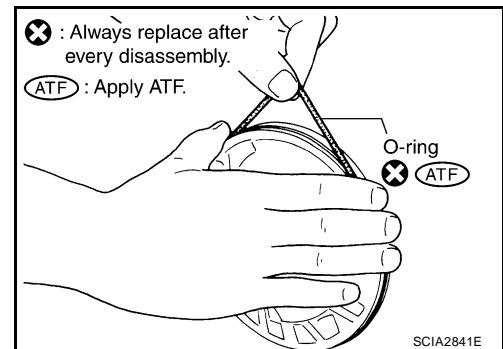

## REPAIR FOR COMPONENT PARTS

3. Install oil pump housing oil seal to the oil pump housing until it is flush using Tool.

**Tool number : ST33400001 (J-26082)**

**CAUTION:**

- Do not reuse oil seal.
- Apply ATF to oil seal.

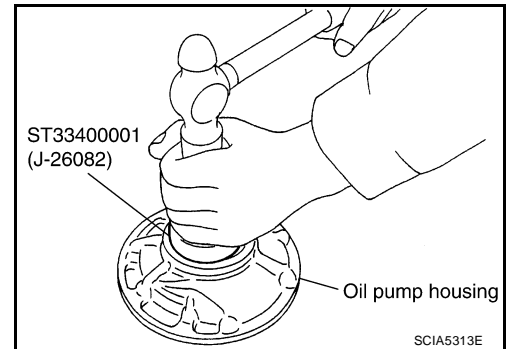

4. After temporarily tightening the bolts for the oil pump housing to the oil pump cover, tighten them to the specified torque in the order shown.

**Oil pump housing bolts : 9.0 N·m (0.92 kg·m, 80 in·lb.)**

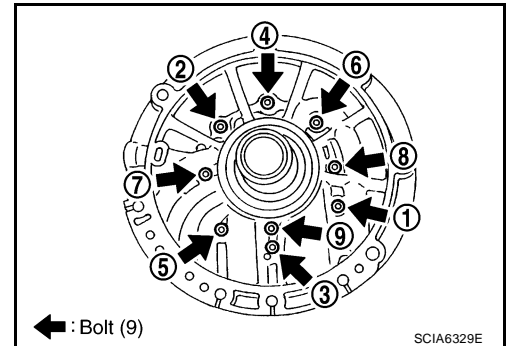

A

B

AT

D

E

F

G

H

I

J

K

L

M

# REPAIR FOR COMPONENT PARTS

## Front Sun Gear, 3rd One-Way Clutch COMPONENTS

UCS00494

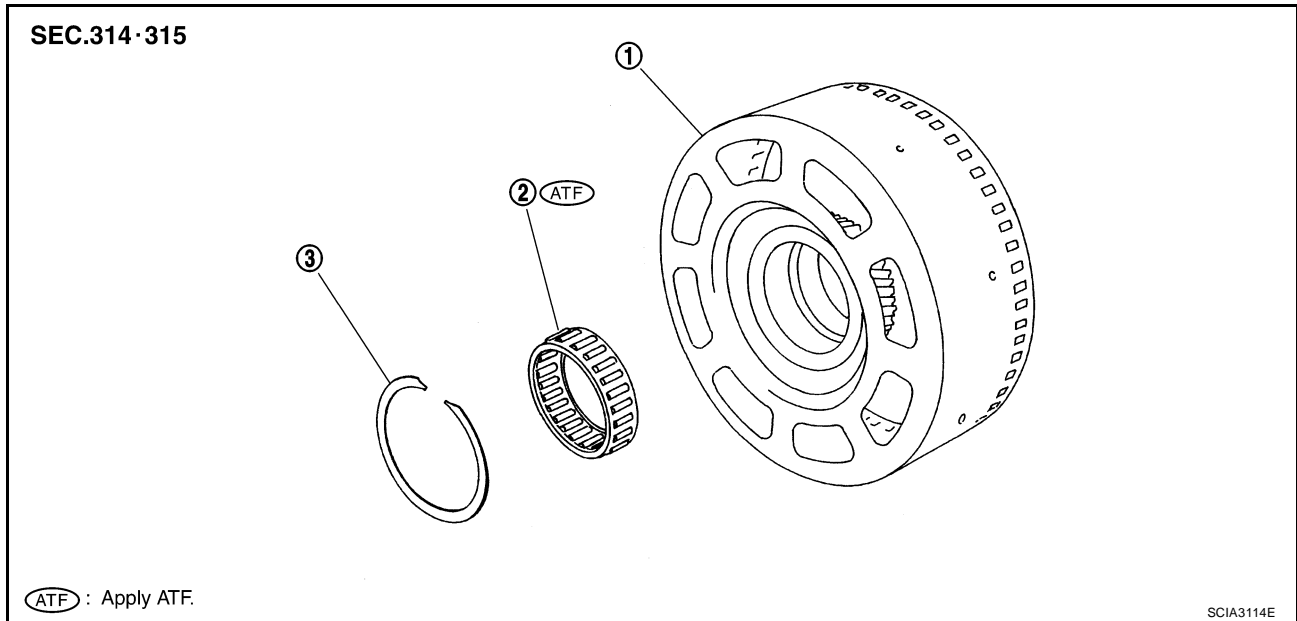

1. Front sun gear

2. 3rd one-way clutch

3. Snap ring

### DISASSEMBLY

1. Remove snap ring from front sun gear using suitable tool.

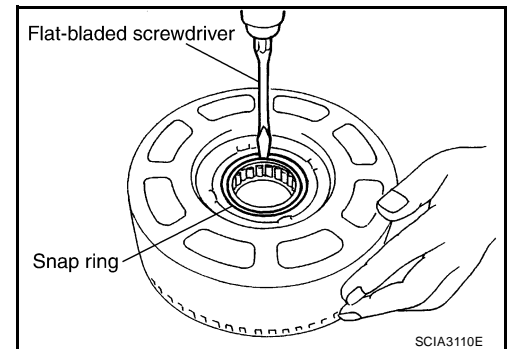

2. Remove 3rd one-way clutch from front sun gear.

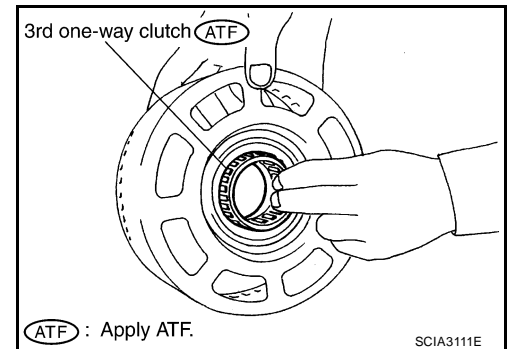



# REPAIR FOR COMPONENT PARTS

## INSPECTION

### 3rd One-way Clutch

- Check frictional surface for wear or damage.

**CAUTION:**

If necessary, replace the 3rd one-way clutch.

### Front Sun Gear Snap Ring

- Check for deformation, fatigue or damage.

**CAUTION:**

If necessary, replace the snap ring.

### Front Sun Gear

- Check for deformation, fatigue or damage.

**CAUTION:**

If necessary, replace the front sun gear.

## ASSEMBLY

1. Install 3rd one-way clutch in front sun gear.

**CAUTION:**

Apply ATF to 3rd one-way clutch.

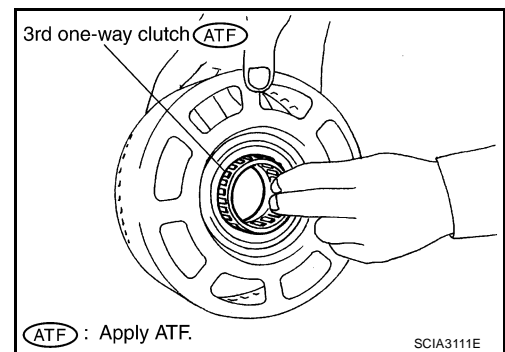

2. Install snap ring in front sun gear using suitable tool.

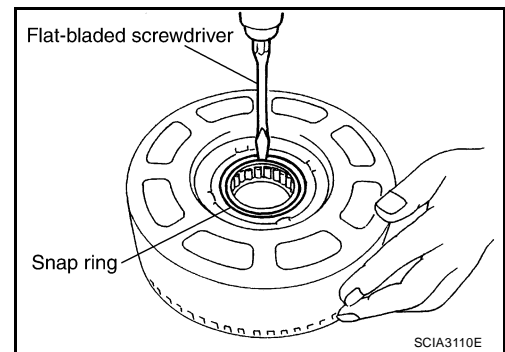

3. Check operation of 3rd one-way clutch.

- a. Hold oil pump assembly and turn front sun gear.

- b. Check 3rd one-way clutch for correct locking and unlocking directions.

**CAUTION:**

If not as shown, check installation direction of 3rd one-way clutch.

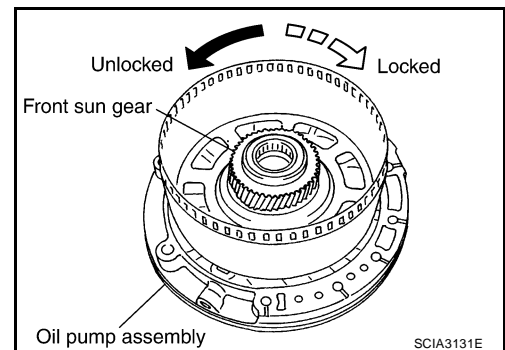

A

B

AT

D

E

F

G

H

I

J

K

L

M

# REPAIR FOR COMPONENT PARTS

## Front Carrier, Input Clutch, Rear Internal Gear COMPONENTS

UCS00495

SEC.314 • 315

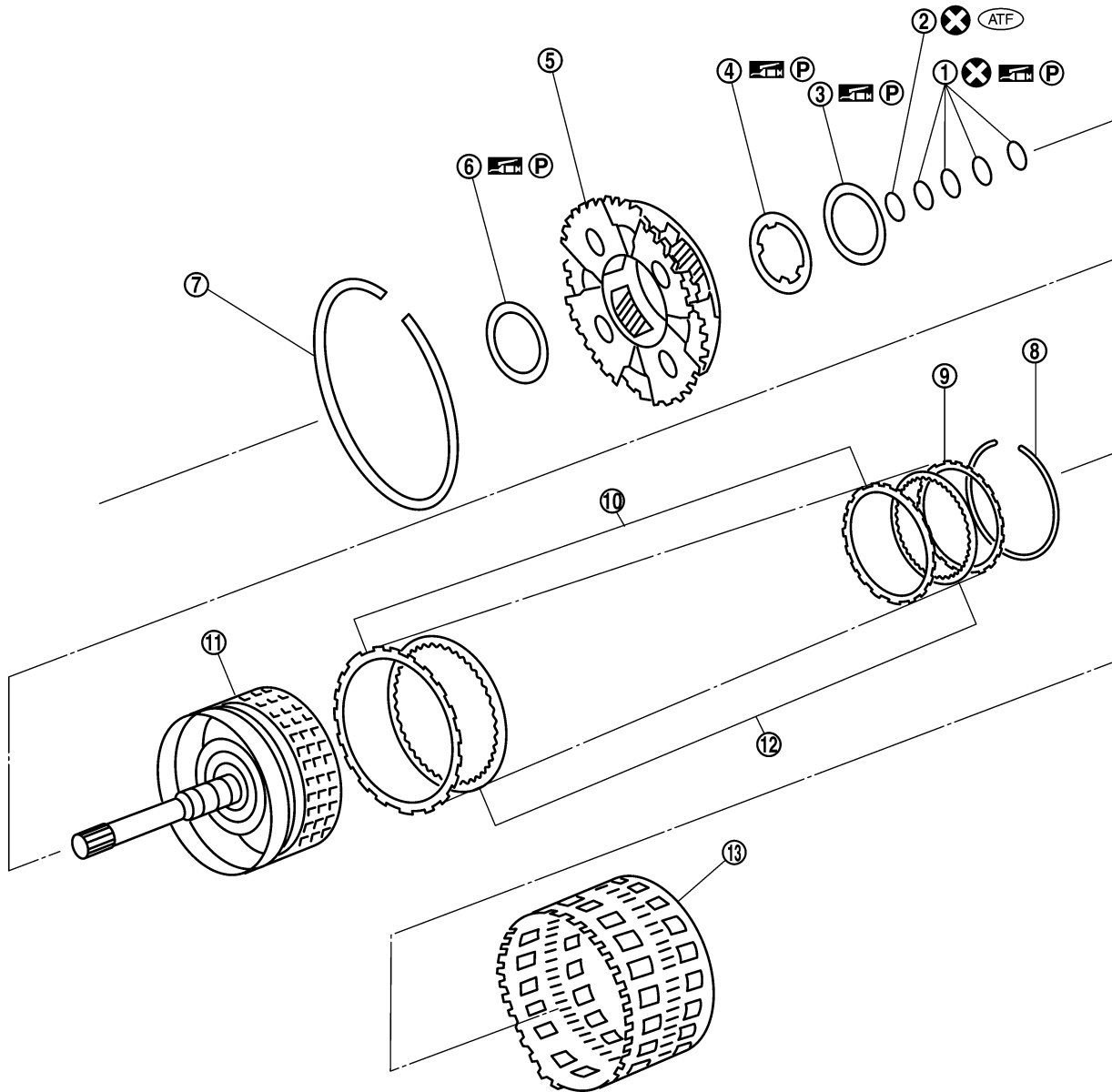

- 1. Seal ring
- 4. Bearing race
- 7. Snap ring
- 10. Driven plate
- 13. Rear internal gear

- 2. O-ring
- 5. Front carrier assembly
- 8. Snap ring
- 11. Input clutch drum

- 3. Needle bearing
- 6. Needle bearing
- 9. Retaining plate
- 12. Drive plate

SCIA6734E

# REPAIR FOR COMPONENT PARTS

## DISASSEMBLY

1. Compress snap ring using suitable tools.
2. Remove front carrier assembly and input clutch assembly from rear internal gear.
3. Remove front carrier assembly from input clutch assembly.

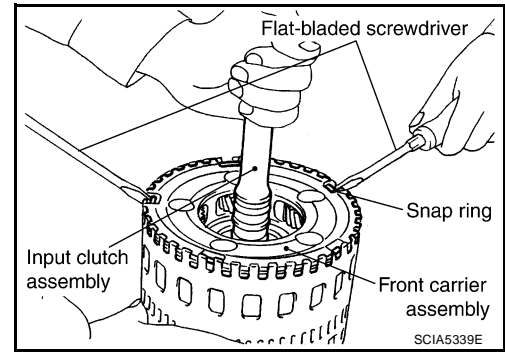

- a. Remove bearing race from front carrier assembly.

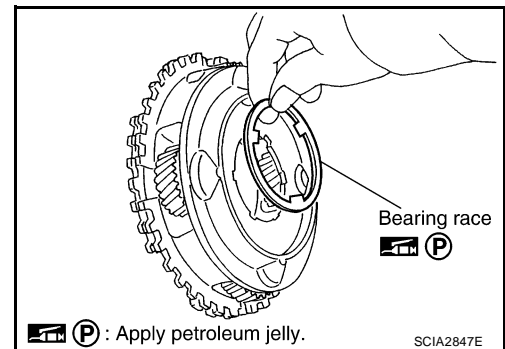

- b. Remove needle bearing from front carrier assembly.

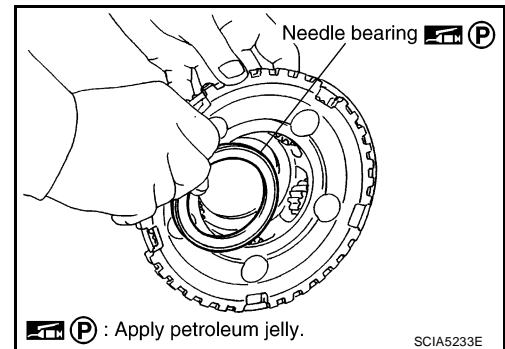

- c. Remove snap ring from front carrier assembly.

**CAUTION:**  
Do not expand snap ring excessively.

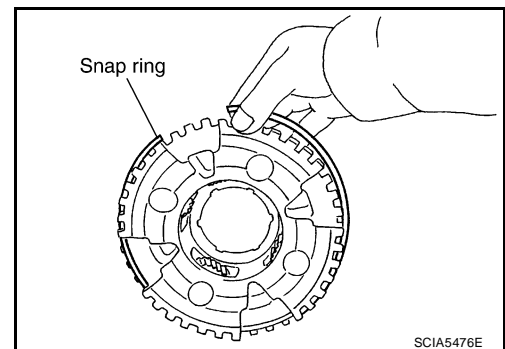

A  
B  
AT  
D  
E  
F  
G  
H  
I  
J  
K  
L  
M

## REPAIR FOR COMPONENT PARTS

4. Disassemble input clutch assembly.
  - a. Remove O-ring and seal rings from input clutch assembly.

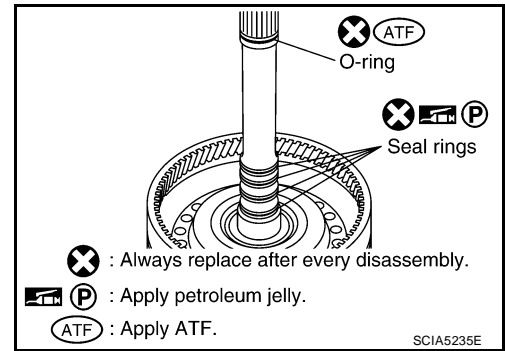

- b. Remove needle bearing from input clutch assembly.

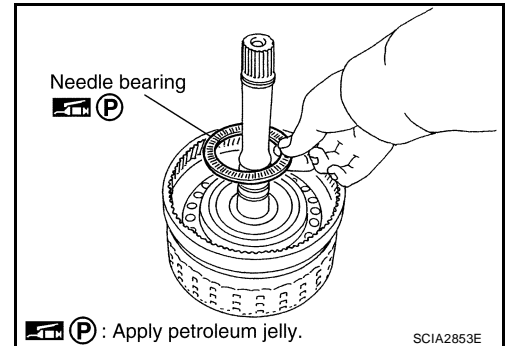

- c. Remove snap ring from input clutch drum using suitable tools.
  - d. Remove drive plates, driven plates and retaining plate from input clutch drum.

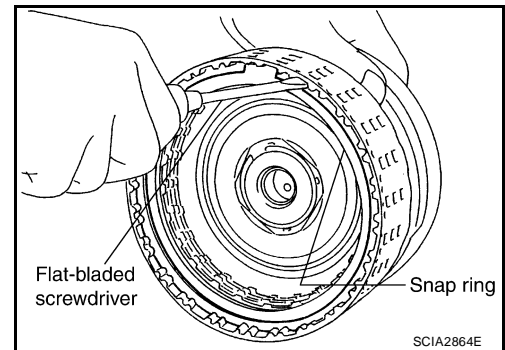

### INSPECTION

#### Front Carrier Snap Ring

- Check for deformation, fatigue or damage.

#### **CAUTION:**

If necessary, replace the snap ring.

#### Input Clutch Snap Ring

- Check for deformation, fatigue or damage.

#### **CAUTION:**

If necessary, replace the input clutch assembly.

#### Input Clutch Drum

- Check for deformation, fatigue or damage or burns.

#### **CAUTION:**

If necessary, replace the input clutch assembly.

#### Input Clutch Drive Plates

- Check facing for burns, cracks or damage.

#### **CAUTION:**

If necessary, replace the input clutch assembly.

#### Input Clutch Retaining Plate and Driven Plates

- Check facing for burns, cracks or damage.

# REPAIR FOR COMPONENT PARTS

---

**CAUTION:**

If necessary, replace the input clutch assembly.

A

## Front Carrier

- Check for deformation, fatigue or damage.

**CAUTION:**

If necessary, replace the front carrier assembly.

B

## Rear Internal Gear

- Check for deformation, fatigue or damage.

**CAUTION:**

If necessary, replace the rear internal gear assembly.

AT

D

E

F

G

H

I

J

K

L

M

# REPAIR FOR COMPONENT PARTS

## ASSEMBLY

1. Install input clutch.
- a. Install drive plates, driven plates and retaining plate in input clutch drum.

- QR25DE models

- Snap ring (1)
- Retaining plate (2)
- Drive plate (3)
- Driven plate (4)

**CAUTION:**

**Take care with order of plates.**

**NOTE:**

There are 5 drive plates and 5 driven plates.

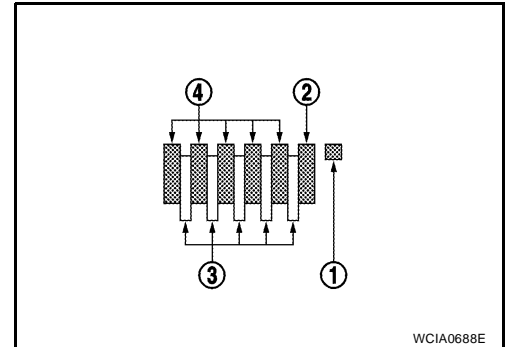

- VQ40DE models

- Snap ring (1)
- Retaining plate (2)
- Drive plate (3)
- Driven plate (4)

**CAUTION:**

**Take care with order of plates.**

**NOTE:**

There are 7 drive plates and 7 driven plates.

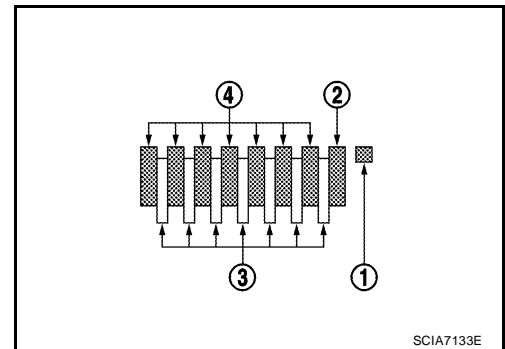

- b. Install snap ring in input clutch drum using suitable tool.

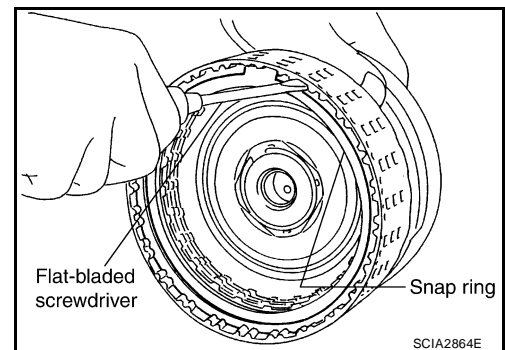

- c. Install needle bearing in input clutch assembly.

**CAUTION:**

**Apply petroleum jelly to needle bearing.**

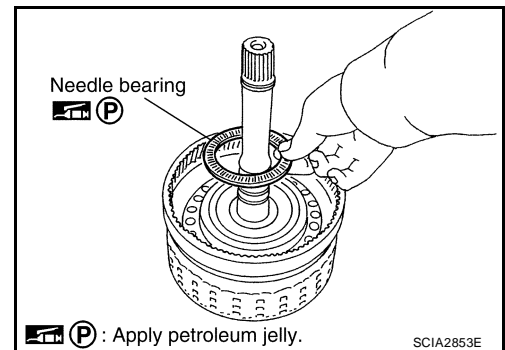

## REPAIR FOR COMPONENT PARTS

- d. Install O-ring and seal rings in input clutch assembly.

**CAUTION:**

- Do not reuse O-ring and seal rings.
- Apply ATF to O-ring.
- Apply petroleum jelly to seal rings.

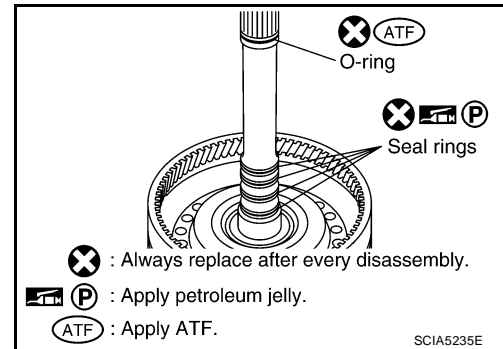

2. Install front carrier assembly.  
a. Install snap ring to front carrier assembly.

**CAUTION:**

- Do not expand snap ring excessively.

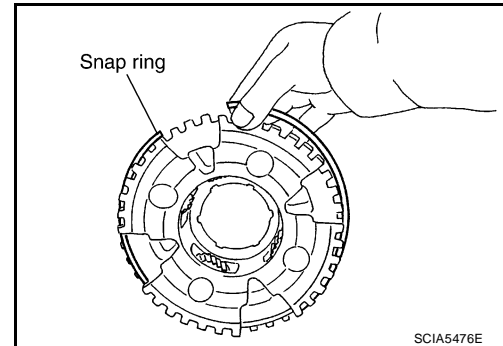

- b. Install needle bearing in front carrier assembly.

**CAUTION:**

- Take care with the direction of needle bearing. Refer to [AT-266, "Locations of Adjusting Shims, Needle Bearings, Thrust Washers and Snap Rings"](#) .
- Apply petroleum jelly to bearing race.

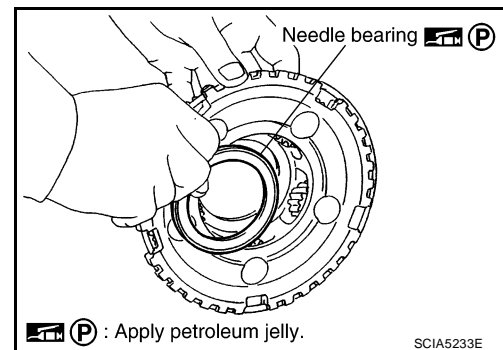

- c. Install bearing race in front carrier assembly.

**CAUTION:**

- Apply petroleum jelly to bearing race.

- d. Install front carrier assembly to input clutch assembly.

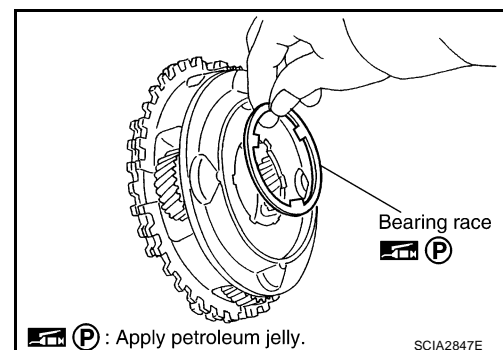

3. Compress snap ring using suitable tools.  
4. Install front carrier assembly and input clutch assembly to rear internal gear.

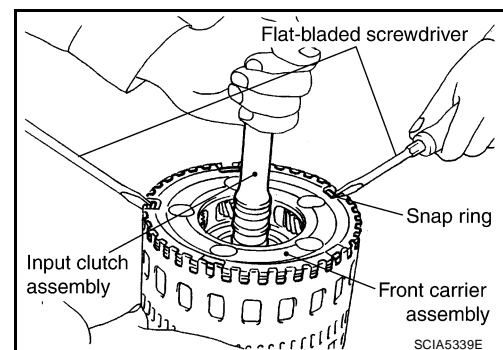

# REPAIR FOR COMPONENT PARTS

## Mid Sun Gear, Rear Sun Gear, High and Low Reverse Clutch Hub COMPONENTS

UCS00496

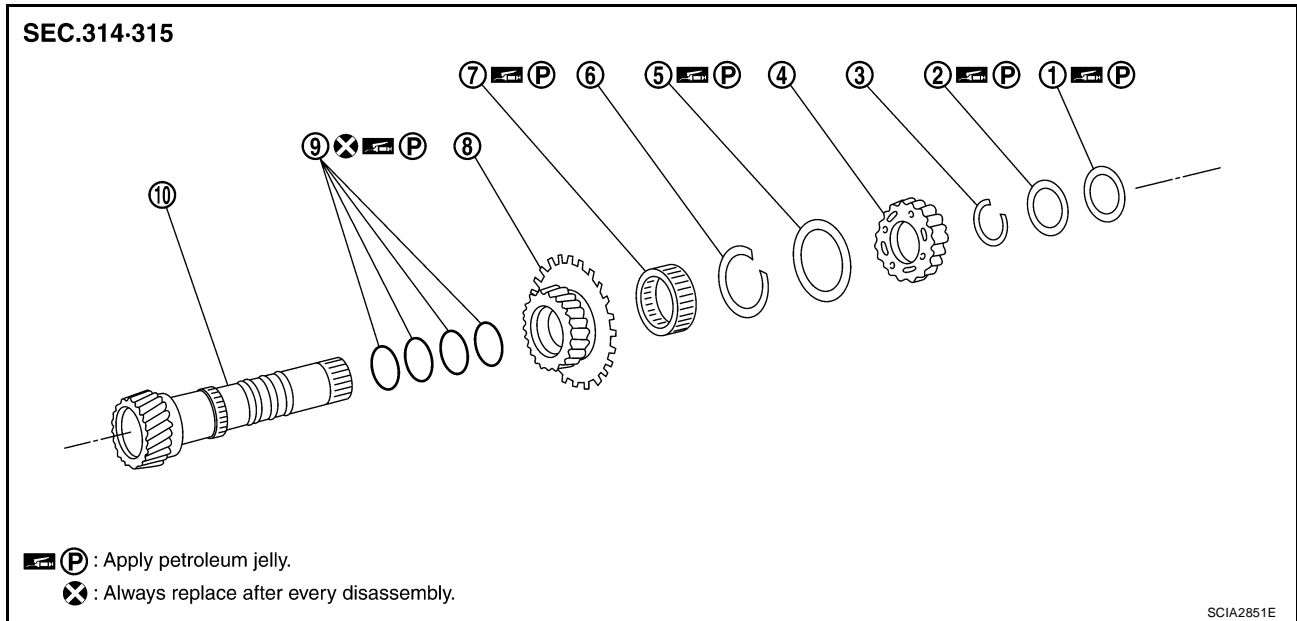

- |                                    |                   |              |
|------------------------------------|-------------------|--------------|
| 1. Needle bearing                  | 2. Bearing race   | 3. Snap ring |
| 4. High and low reverse clutch hub | 5. Needle bearing | 6. Snap ring |
| 7. 1st one-way clutch              | 8. Rear sun gear  | 9. Seal ring |
| 10. Mid sun gear                   |                   |              |

### DISASSEMBLY

1. Remove needle bearing and bearing race from high and low reverse clutch hub.

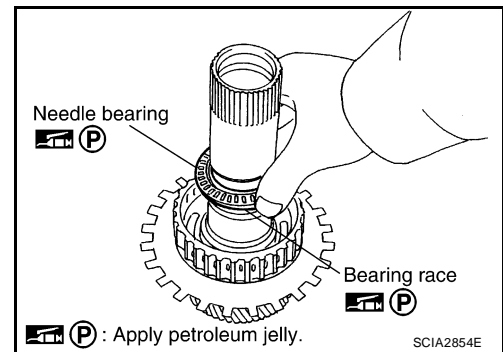

2. Remove snap ring from mid sun gear assembly using suitable tool.

### CAUTION:

Do not expand snap ring excessively.

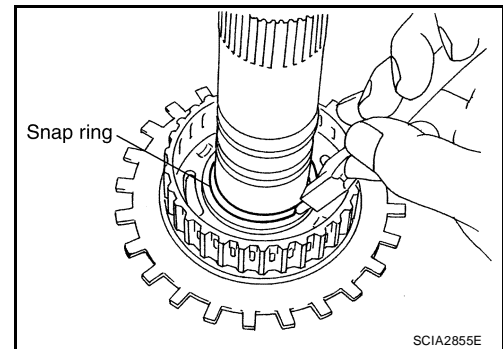



# REPAIR FOR COMPONENT PARTS

3. Remove high and low reverse clutch hub from mid sun gear assembly.

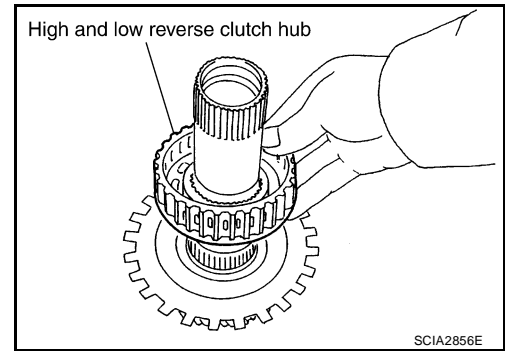

- a. Remove needle bearing from high and low reverse clutch hub.

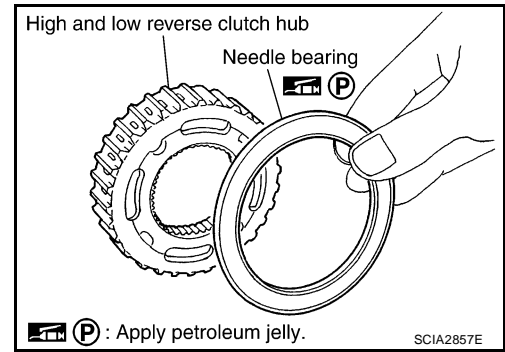

4. Remove rear sun gear assembly from mid sun gear assembly.

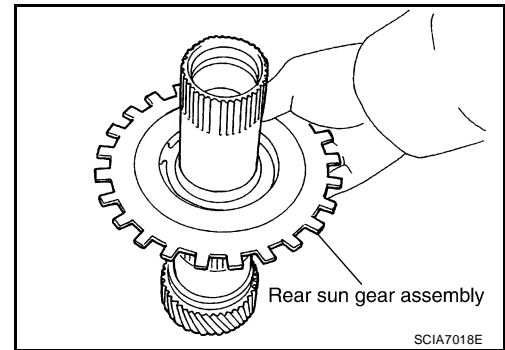

- a. Remove snap ring from rear sun gear using suitable tool.

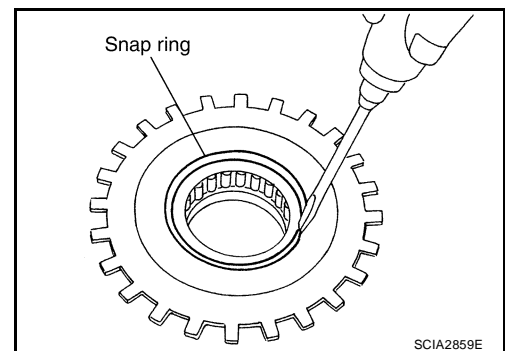

A  
B  
AT  
D  
E  
F  
G  
H  
I  
J  
K  
L  
M

## REPAIR FOR COMPONENT PARTS

- b. Remove 1st one-way clutch from rear sun gear.

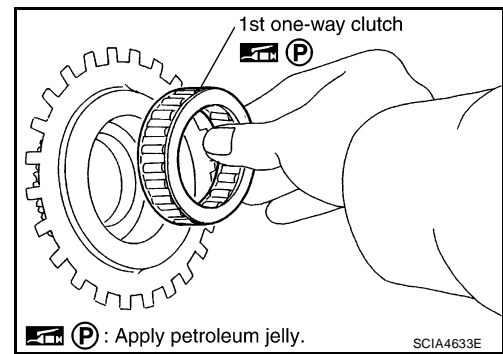

5. Remove seal rings from mid sun gear.

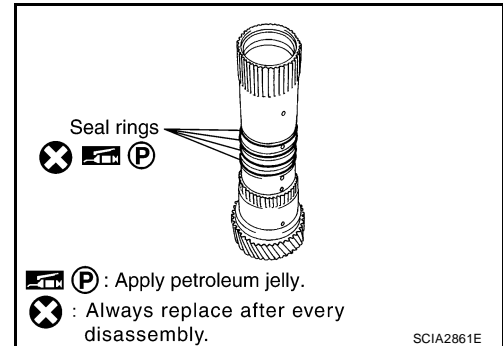

### INSPECTION

#### High and Low Reverse Clutch Hub Snap Ring, Rear Sun Gear Snap Ring

- Check for deformation, fatigue or damage.

**CAUTION:**

If necessary, replace the snap ring.

#### 1st One-way Clutch

- Check frictional surface for wear or damage.

**CAUTION:**

If necessary, replace the 1st one-way clutch.

#### Mid Sun Gear

- Check for deformation, fatigue or damage.

**CAUTION:**

If necessary, replace the mid sun gear.

#### Rear Sun Gear

- Check for deformation, fatigue or damage.

**CAUTION:**

If necessary, replace the rear sun gear.

#### High and Low Reverse Clutch Hub

- Check for deformation, fatigue or damage.

**CAUTION:**

If necessary, replace the high and low reverse clutch hub.

# REPAIR FOR COMPONENT PARTS

## ASSEMBLY

1. Install seal rings to mid sun gear.

**CAUTION:**

- Do not reuse seal rings.
- Apply petroleum jelly to seal rings.

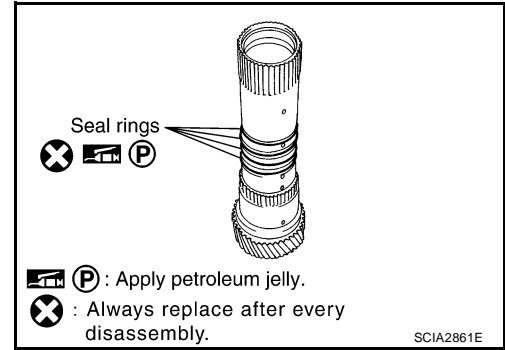

2. Install 1st one-way clutch to rear sun gear.

**CAUTION:**

- Apply petroleum jelly to 1st one-way clutch.

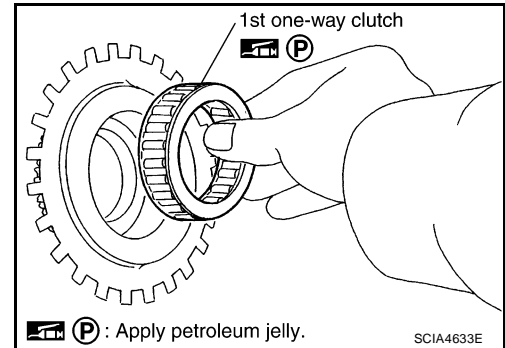

3. Install snap ring to rear sun gear using suitable tool.

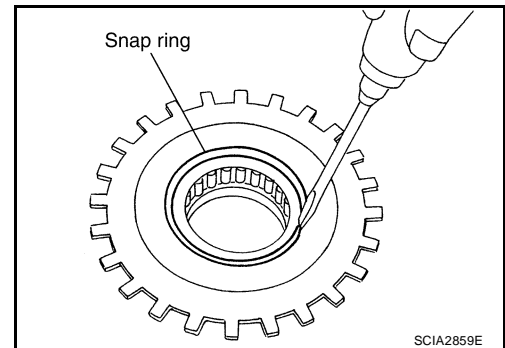

4. Install rear sun gear assembly to mid sun gear assembly.

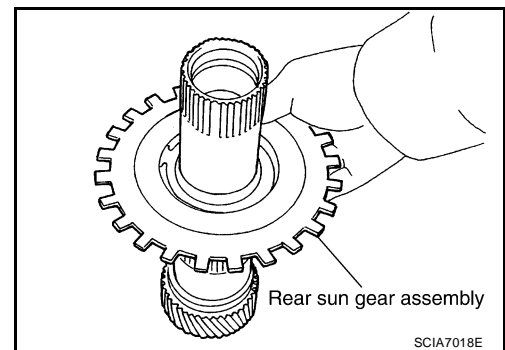

A  
B  
AT  
D  
E  
F  
G  
H  
I  
J  
K  
L  
M

## REPAIR FOR COMPONENT PARTS

5. Install needle bearing to high and low reverse clutch hub.

**CAUTION:**

Apply petroleum jelly to needle bearing.

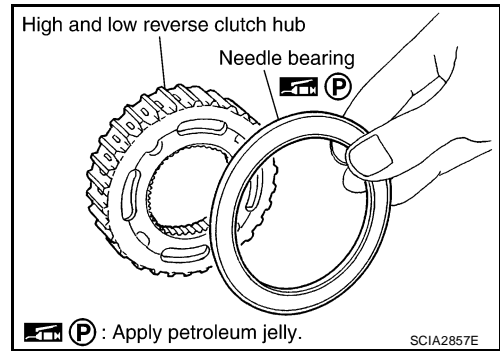

6. Install high and low reverse clutch hub to mid sun gear assembly.

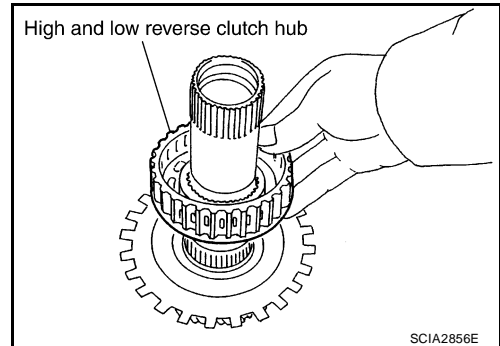

7. Install snap ring to mid sun gear assembly using suitable tool.

**CAUTION:**

Do not expand snap ring excessively.

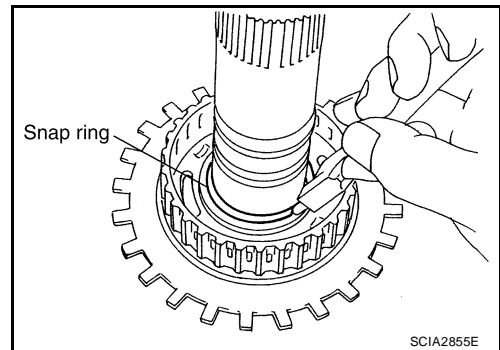

8. Check operation of 1st one-way clutch.

- a. Hold mid sun gear and turn rear sun gear.  
b. Check 1st one-way clutch for correct locking and unlocking directions.

**CAUTION:**

If not as shown, check installation direction of 1st one-way clutch.

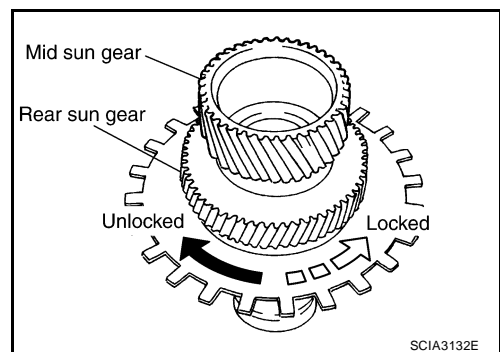

9. Install needle bearing and bearing race to high and low reverse clutch hub.

**CAUTION:**

Apply petroleum jelly to needle bearing and bearing race.

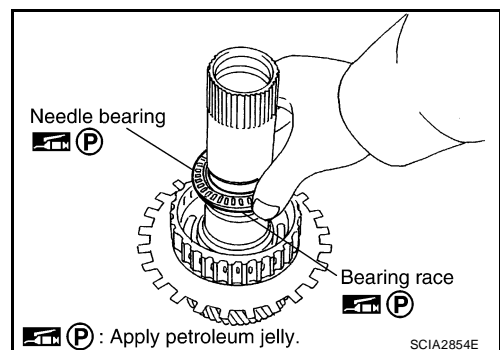



# REPAIR FOR COMPONENT PARTS

## High and Low Reverse Clutch COMPONENTS

UCS00497

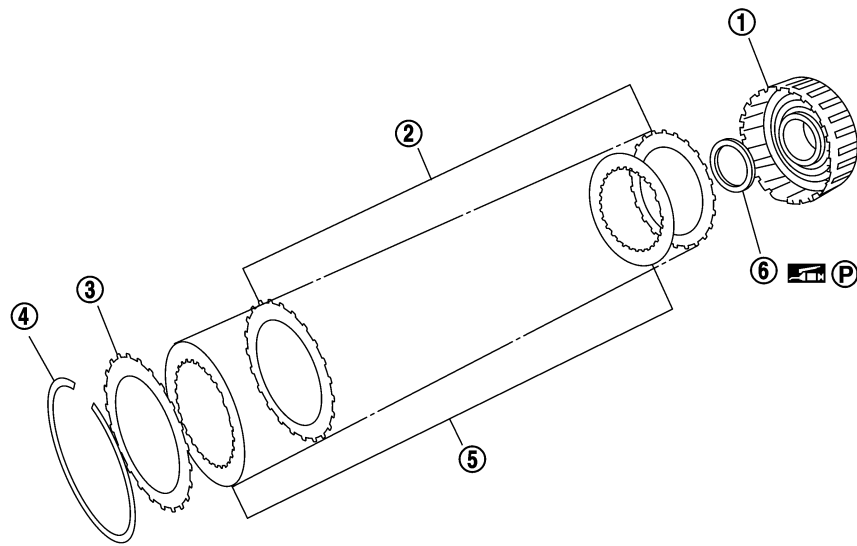
SEC.315



 (P) : Apply petroleum jelly.

SCIA5239E

- |                                     |                 |                    |
|-------------------------------------|-----------------|--------------------|
| 1. High and low reverse clutch drum | 2. Driven plate | 3. Retaining plate |
| 4. Snap ring                        | 5. Drive plate  | 6. Bearing race    |

### DISASSEMBLY

1. Remove bearing race from high and low reverse clutch drum.

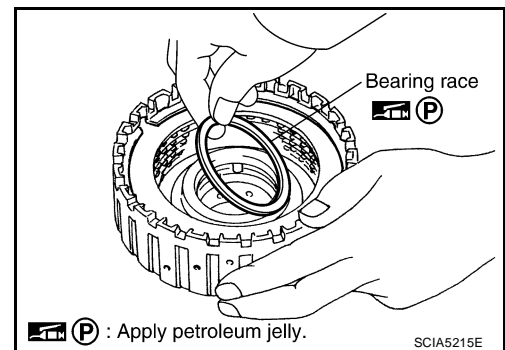

 (P) : Apply petroleum jelly.

SCIA5215E

2. Remove snap ring from high and low reverse clutch drum using suitable tool.
3. Remove drive plates, driven plates and retaining plate from high and low reverse clutch drum.

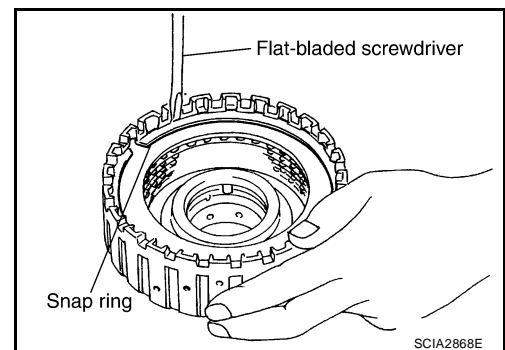

Snap ring

Flat-bladed screwdriver

SCIA2868E

A  
B  
AT  
D  
E  
F  
G  
H  
I  
J  
K  
L  
M

# REPAIR FOR COMPONENT PARTS

## INSPECTION

- Check the following, and replace high and low reverse clutch assembly if necessary.

### High and Low Reverse Clutch Snap Ring

- Check for deformation, fatigue or damage.

### High and Low Reverse Clutch Drive Plates

- Check facing for burns, cracks or damage.

### High and Low Reverse Clutch Retaining Plate and Driven Plates

- Check facing for burns, cracks or damage.

## ASSEMBLY

1. Install drive plates, driven plates and retaining plate in high and low reverse clutch drum.

- QR25DE models

- Snap ring (1)
- Retaining plate (2)
- Drive plate (3)
- Driven plate (4)

**CAUTION:**

**Take care with order of plates.**

**NOTE:**

There are 4 drive plates and 4 driven plates.

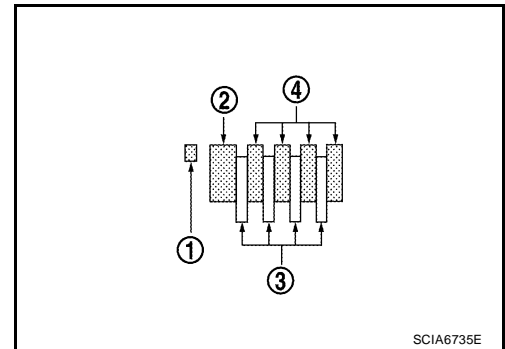

- VQ40DE models

- Snap ring (1)
- Retaining plate (2)
- Drive plate (3)
- Driven plate (4)

**CAUTION:**

**Take care with order of plates.**

**NOTE:**

There are 5 drive plates and 5 driven plates.

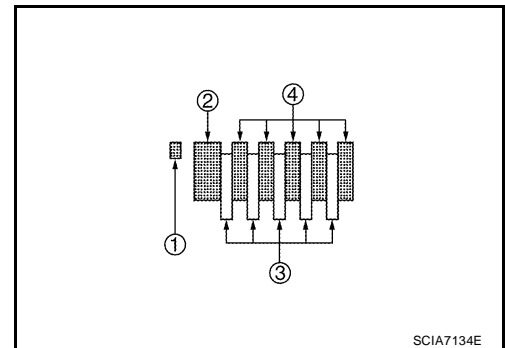

2. Install snap ring in high and low reverse clutch drum using suitable tool.

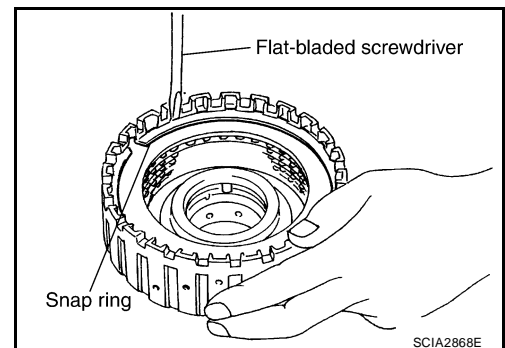

## REPAIR FOR COMPONENT PARTS

3. Install bearing race to high and low reverse clutch drum.

**CAUTION:**

**Apply petroleum jelly to bearing race.**

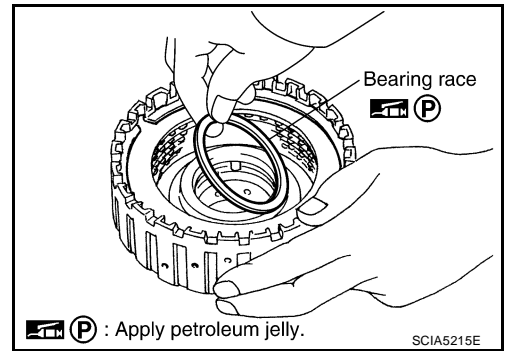

A

B

AT

D

E

F

G

H

I

J

K

L

M

# REPAIR FOR COMPONENT PARTS

## Direct Clutch COMPONENTS

UCS00498

### QR25DE models

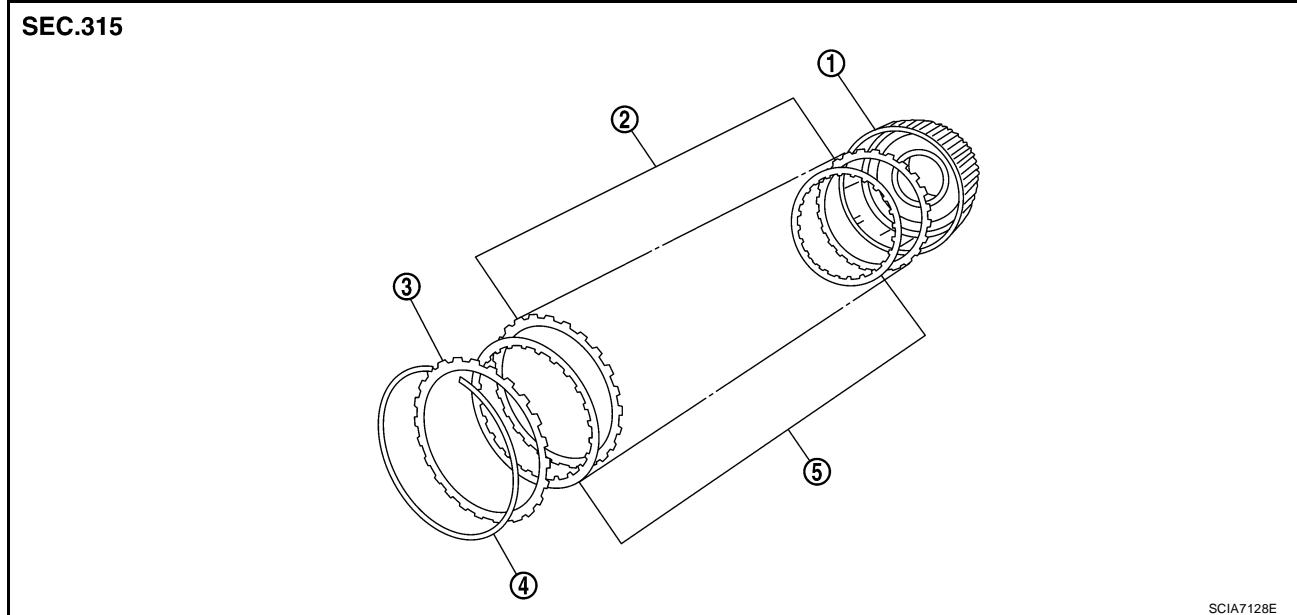

- |                       |                 |                    |
|-----------------------|-----------------|--------------------|
| 1. Direct clutch drum | 2. Driven plate | 3. Retaining plate |
| 4. Snap ring          | 5. Drive plate  |                    |

### VQ40DE models

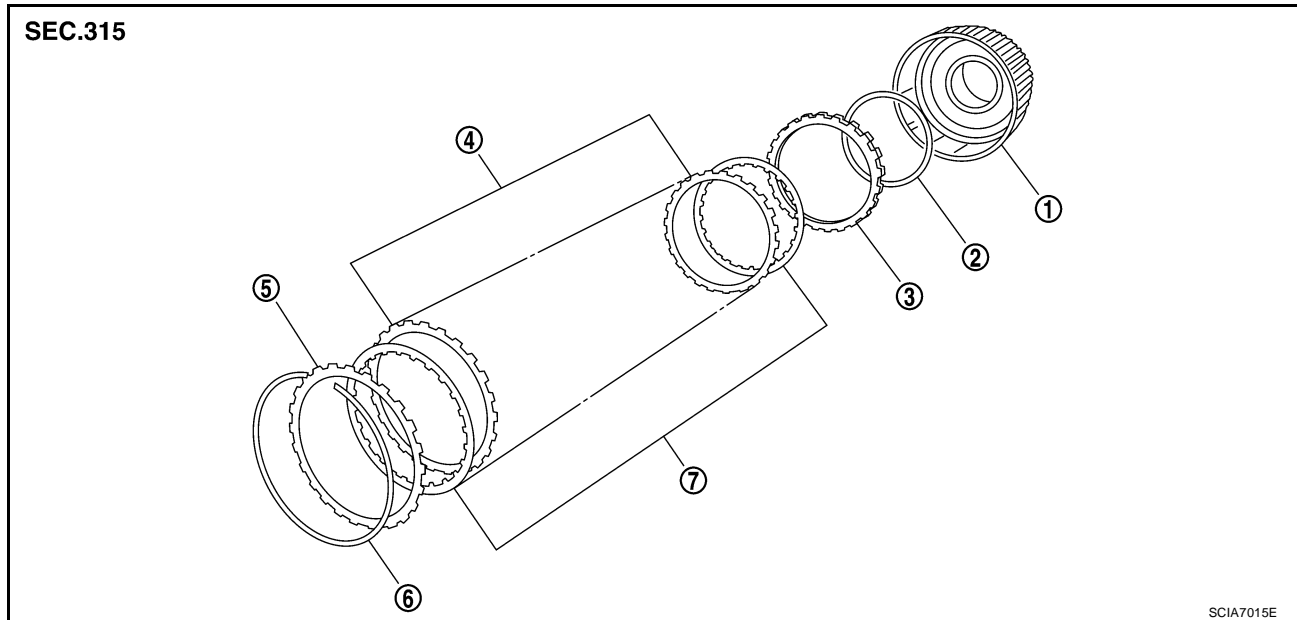

- |                       |                    |                    |
|-----------------------|--------------------|--------------------|
| 1. Direct clutch drum | 2. Dish plate      | 3. Retaining plate |
| 4. Driven plate       | 5. Retaining plate | 6. Snap ring       |
| 7. Drive plate        |                    |                    |



# REPAIR FOR COMPONENT PARTS

## DISASSEMBLY

1. Remove snap ring from direct clutch drum using suitable tool.
2. Remove retaining plates, drive plates, driven plates and dish plate (VQ40DE models) from direct clutch drum.

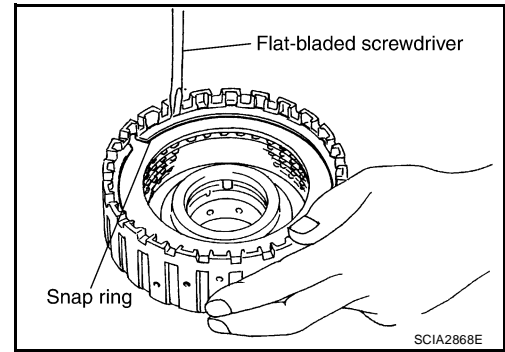

## INSPECTION

- Check the following, and replace direct clutch assembly if necessary.

### Direct Clutch Snap Ring

- Check for deformation, fatigue or damage.

### Direct Clutch Drive Plates

- Check facing for burns, cracks or damage.

### Direct Clutch Retaining Plate and Driven Plates

- Check facing for burns, cracks or damage.

A  
B  
AT  
D  
E  
F  
G  
H  
I  
J  
K  
L  
M

# REPAIR FOR COMPONENT PARTS

## ASSEMBLY

1. Install dish plate (VQ40DE models), retaining plates, drive plates and driven plates in direct clutch drum.

- QR25DE models
  - Snap ring (1)
  - Retaining plate (2)
  - Drive plate (3)
  - Driven plate (4)

**CAUTION:**

**Take care with order of plates.**

**NOTE:**

There are 5 drive plates and 5 driven plates.

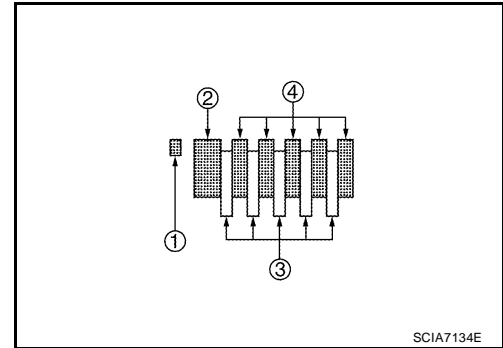

- VQ40DE models
  - Snap ring (1)
  - Retaining plate (2)
  - Drive plate (3)
  - Driven plate (4)
  - Dish plate (5)

**CAUTION:**

**Take care with order of plates.**

**NOTE:**

There are 5 drive plates and 4 driven plates.

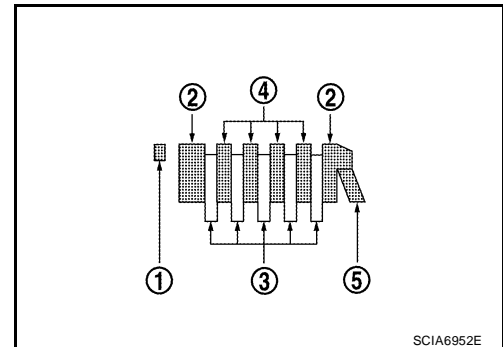

2. Install snap ring in direct clutch drum using suitable tool.

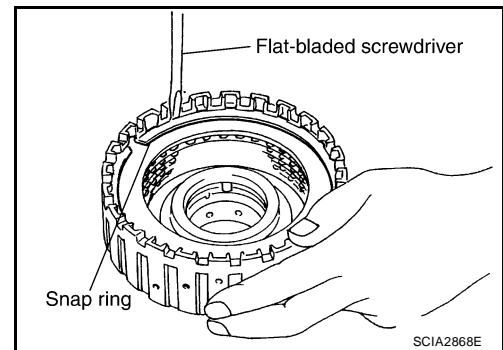

# ASSEMBLY

## ASSEMBLY

PFP:00000

### Assembly (1)

UCS00499

1. Drive manual shaft oil seals into the transmission case until they are flush using suitable tool as shown.

**CAUTION:**

- Apply ATF to manual shaft oil seals.
- Do not reuse manual shaft oil seals.

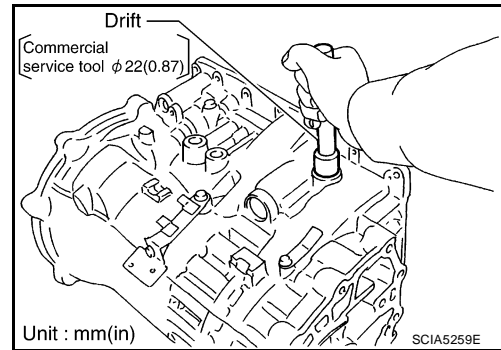

2. Install detent spring and spacer in transmission case and secure with the bolt.

**Bolt : 7.9 N-m (0.81 kg-m, 70 in-lb)**

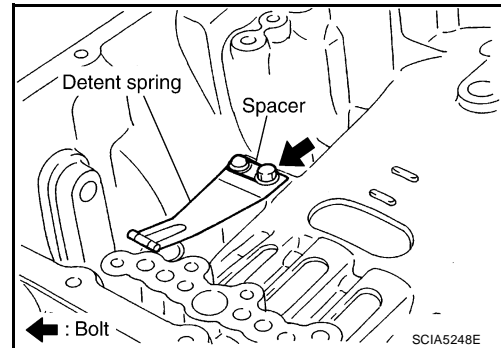

3. Install manual shaft to transmission case.

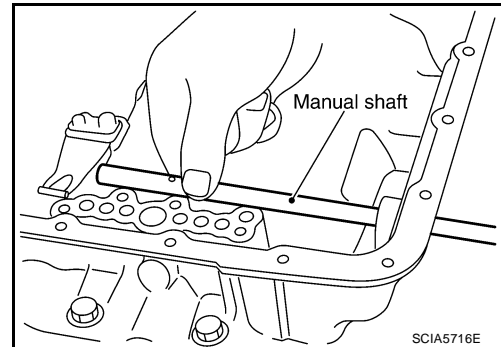

4. Install parking rod to manual plate.

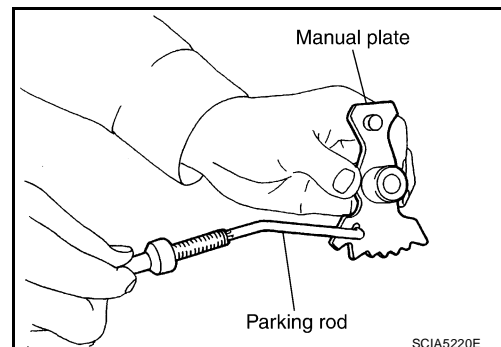

A  
B  
AT  
D  
E  
F  
G  
H  
I  
J  
K  
L  
M

# ASSEMBLY

5. Install manual plate (with parking rod) to manual shaft.

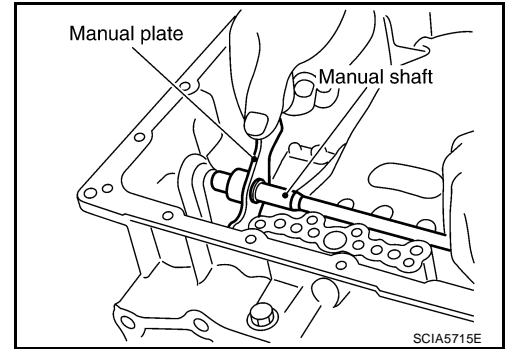

6. Install retaining pin into the manual plate and manual shaft.

- a. Fit pinhole of the manual plate to pinhole of the manual shaft using suitable tool.
- b. Tap the retaining pin into the manual plate.

**CAUTION:**

- Drive retaining pin to  $2 \pm 0.5$  mm ( $0.08 \pm 0.020$  in) over the manual plate.
- Do not reuse retaining pin.

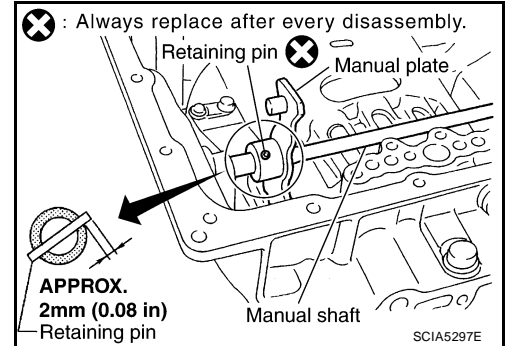

7. Install retaining pin into the transmission case and manual shaft.

- a. Fit pinhole of the transmission case to pinhole of the manual shaft using suitable tool.
- b. Tap the retaining pin into the transmission case.

**CAUTION:**

- Drive retaining pin to  $5 \pm 1$  mm ( $0.20 \pm 0.04$  in) over the transmission case.
- Do not reuse retaining pin.

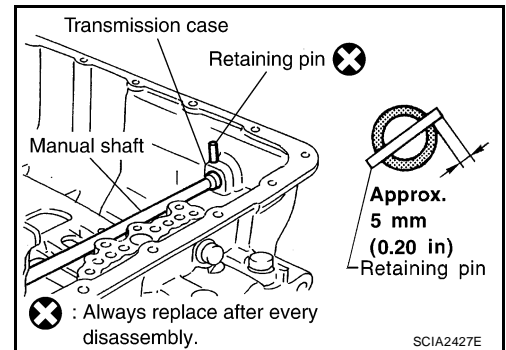

8. Install O-rings to servo assembly.

**CAUTION:**

- Do not reuse O-rings.
- Apply petroleum jelly to O-rings.

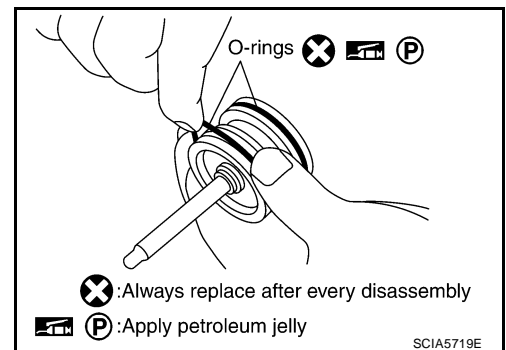

9. Install return spring to servo assembly.

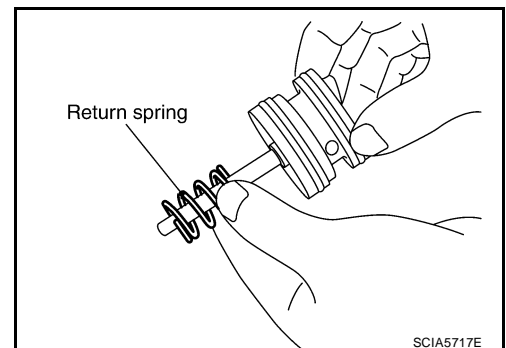

# ASSEMBLY

10. Install servo assembly in transmission case.

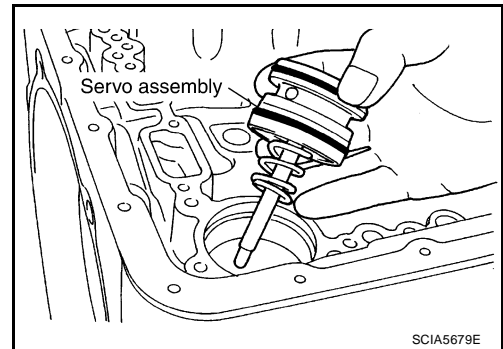

11. Install snap ring to transmission case using suitable tool.

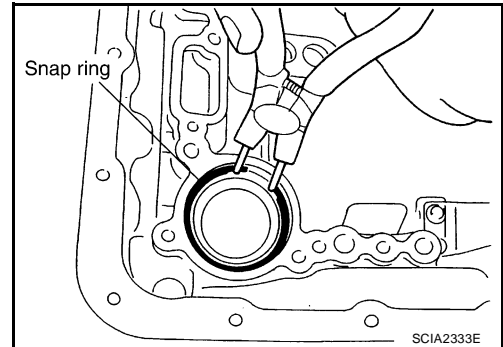

12. Install D-rings in reverse brake piston.

**CAUTION:**

- Do not reuse D-rings.
- Apply ATF to D-rings.

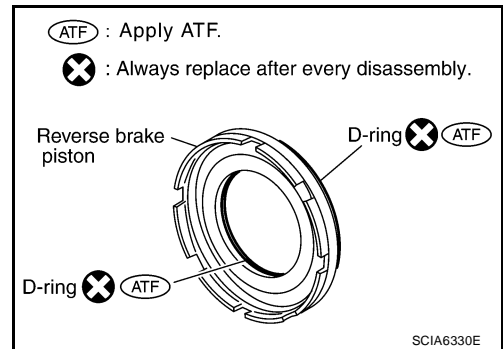

13. Install reverse brake piston in transmission case.

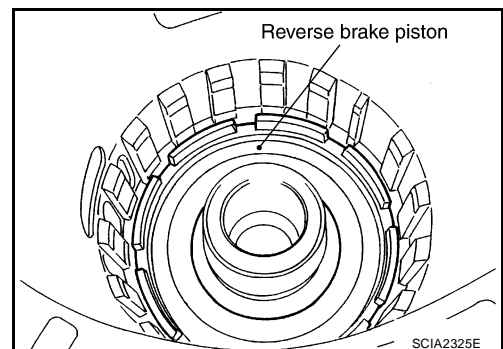

14. Install needle bearing to drum support edge surface.

**CAUTION:**

- Apply petroleum jelly to needle bearing.

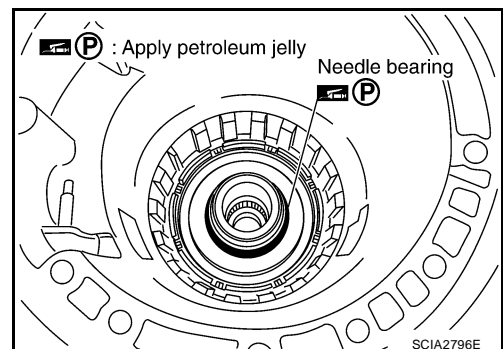

A  
B  
AT  
D  
E  
F  
G  
H  
I  
J  
K  
L  
M

# ASSEMBLY

15. Install seal rings to drum support.

**CAUTION:**

- Do not reuse seal rings.
- Apply petroleum jelly to seal rings.

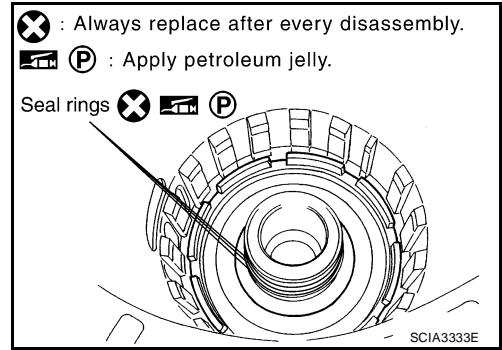

16. Install spring retainer and return spring in transmission case.

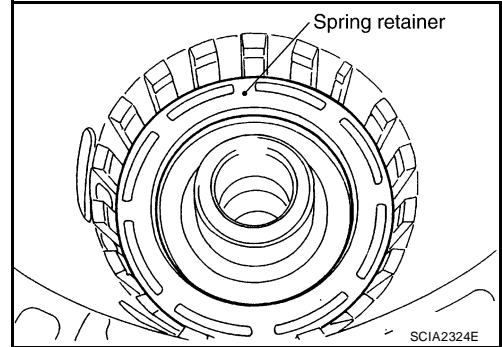

17. install snap ring in transmission case while compressing return spring using Tool.

**Tool number** : KV31102400 (J-34285 and J-34285-87)

**CAUTION:**

Securely assemble them using suitable tool so that snap ring tension is slightly weak.

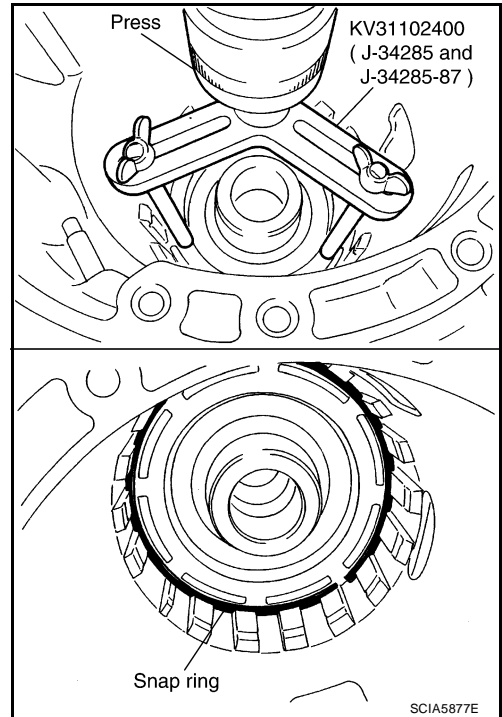

# ASSEMBLY

18. For QR25DE engine install reverse brake drive plates, driven plates and dish plates in transmission case.

**CAUTION:**

**Take care with order of plates.**

**NOTE:**

There are 5 drive plates and 5 driven plates.

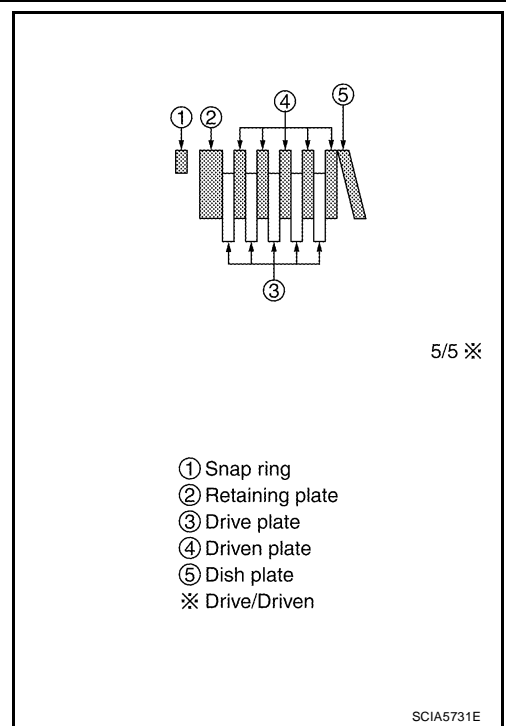

19. For VQ40DE engine install reverse brake drive plates (3), driven plates (4) and dish plates (5) in transmission case.

- Snap ring (1)
- Retaining plate (2)

**CAUTION:**

**Take care with order of plates.**

**NOTE:**

There are 6 drive plates and 6 driven plates.

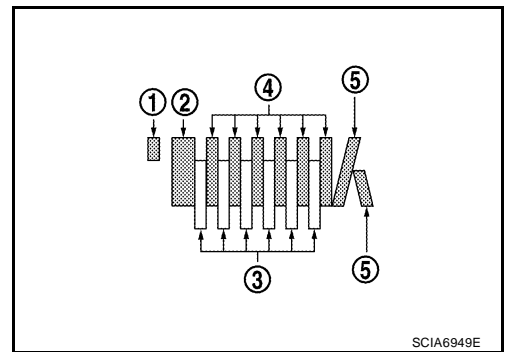

20. Assemble N-spring.

21. Install reverse brake retaining plate in transmission case.

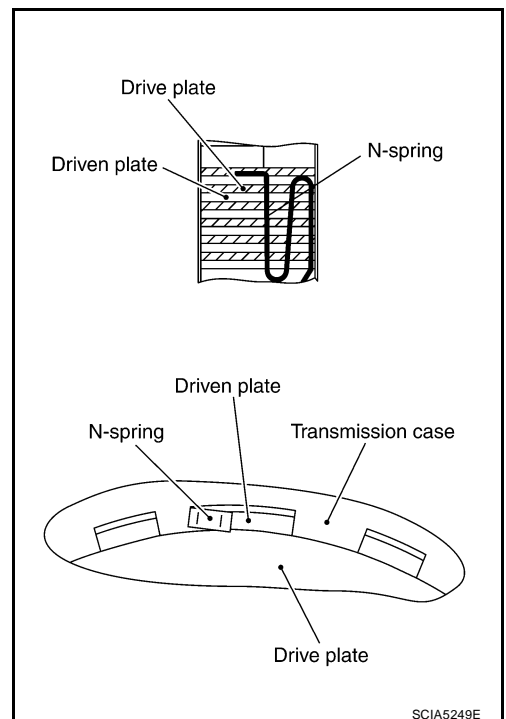

A  
B  
AT  
D  
E  
F  
G  
H  
I  
J  
K  
L  
M

# ASSEMBLY

22. Install snap ring in transmission case.

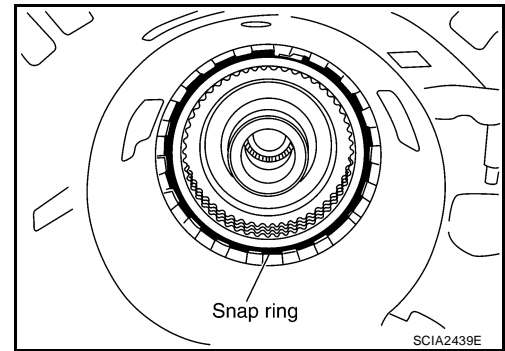

23. Measure clearance between retaining plate and snap ring. If not within specified clearance, select proper retaining plate.

**Specified clearance "A":**

**Standard: 0.7 - 1.1mm (0.028 - 0.043 in)**

**Retaining plate:**

**Refer to [AT-333, "Reverse brake"](#) .**

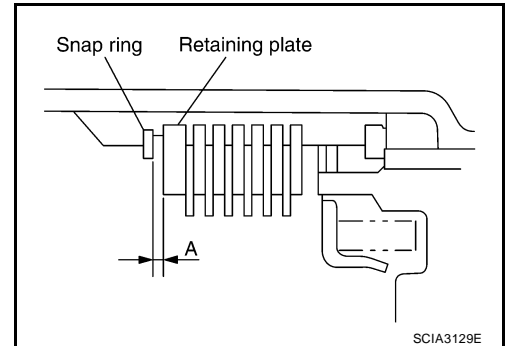

24. Install needle bearing to transmission case.

**CAUTION:**

- Take care with the direction of needle bearing. Refer to [AT-266, "Locations of Adjusting Shims, Needle Bearings, Thrust Washers and Snap Rings"](#) .
- Apply petroleum jelly to needle bearing.

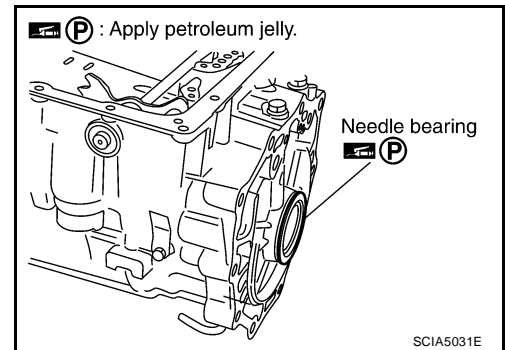

25. Install revolution sensor to transmission case.

**CAUTION:**

- Do not subject it to impact by dropping or hitting it.
- Do not disassemble.
- Do not allow metal filings or debris to get on the sensor's front edge magnetic area.
- Do not place in an area affected by magnetism.

**Revolution sensor : 5.8 N·m (0.59 kg·m, 51 in·lb)**

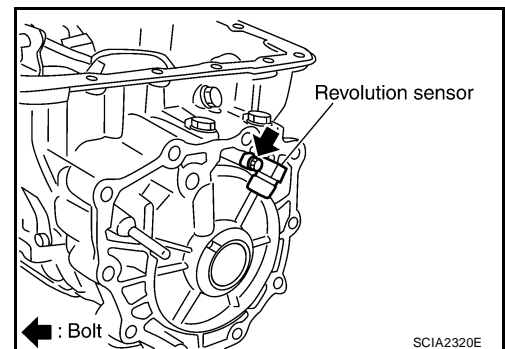

26. Drive rear oil seal into the rear extension until it is flush using Tool.

**Tool number : ST33400001 (J-26082)**

**CAUTION:**

- Apply ATF to rear oil seal.
- Do not reuse rear oil seal.

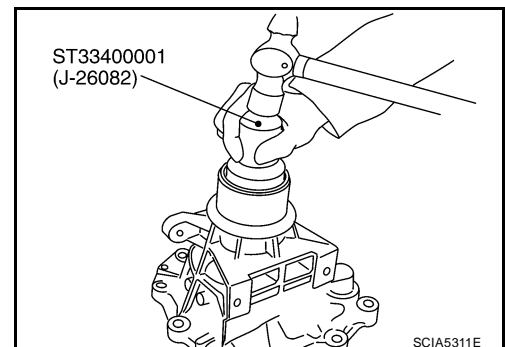



# ASSEMBLY

27. Install new rear oil seal until it is flush into the rear extension case (2WD models) using Tool or adapter case (4WD models) using suitable tool.

**Tool number : ST33400001 (J-26082)**

**CAUTION:**

- Apply ATF to rear oil seal.
- Do not reuse rear oil seal.

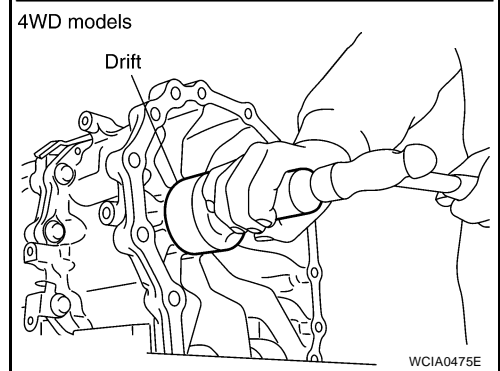
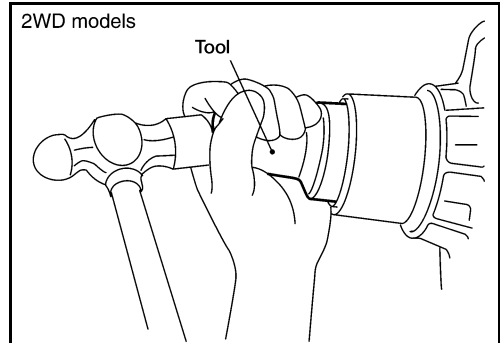

28. Install return spring (1) to parking pawl (2).

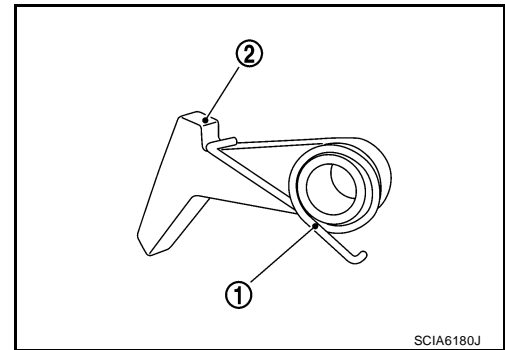

29. Install parking pawl (with return spring) and pawl shaft to rear extension (2WD models) or adapter case (4WD models).

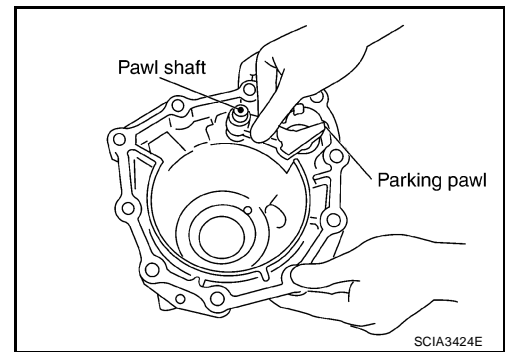

30. Install parking actuator support to rear extension (2WD models) or adapter case (4WD models).

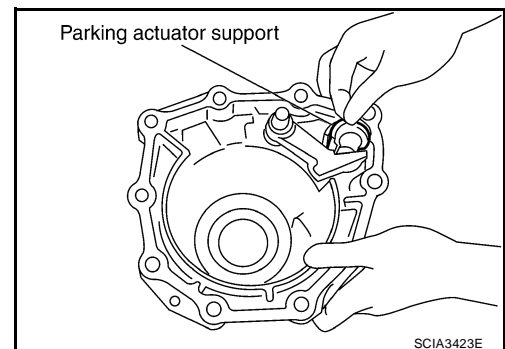

A  
B  
AT  
D  
E  
F  
G  
H  
I  
J  
K  
L  
M

# ASSEMBLY

31. Install needle bearing (1) to rear extension (2WD models) or adapter case (4WD models).

**CAUTION:**

Apply petroleum jelly to needle bearing.

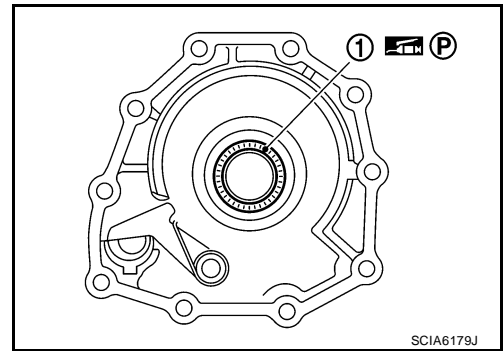

32. Install seal rings to output shaft.

**CAUTION:**

- Do not reuse seal rings.
- Apply petroleum jelly to seal rings.

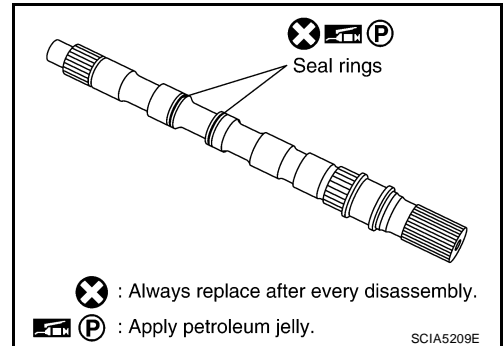

33. Install parking gear to output shaft.

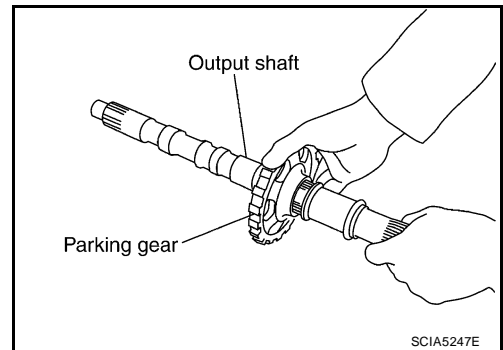

34. Install output shaft in transmission case.

**CAUTION:**

Do not mistake front for rear because both sides look similar. (Thinner end is front side.)

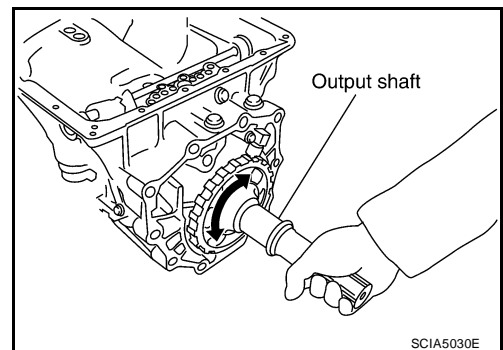

35. Install bearing race to output shaft.

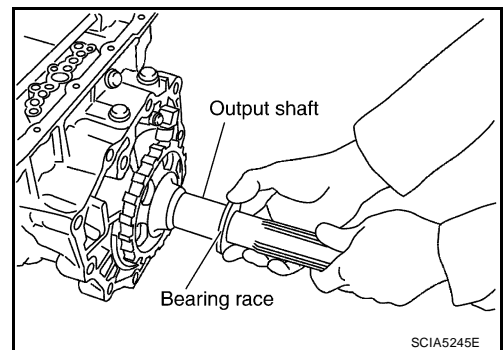

# ASSEMBLY

36. Install rear extension assembly (2WD models) or adapter case assembly (4WD models) according to the following procedures.

a. **2WD models**

i. Apply recommended sealant (Genuine Anaerobic Liquid Gasket or equivalent. Refer to [GI-47, "Recommended Chemical Products and Sealants"](#) .) to rear extension assembly as shown.

**CAUTION:**

Completely remove all moisture, oil and old sealant from the transmission case and rear extension assembly mating surfaces.

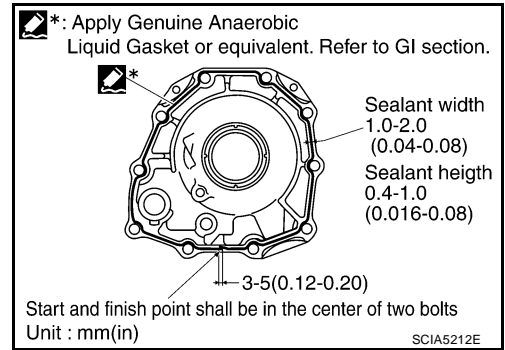

ii. Install rear extension assembly to transmission case.

**CAUTION:**

Insert the tip of parking rod between the parking pawl and the parking actuator support when assembling the rear extension assembly.

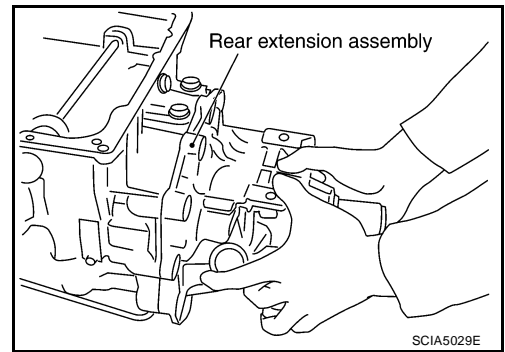

iii. Tighten rear extension assembly bolts to specified torque.

**Rear extension assembly bolt** : 52 N·m (5.3 kg·m, 38 ft·lb)

**Self-sealing bolt** : 61 N·m (6.2 kg·m, 45 ft·lb)

**CAUTION:**

Do not reuse self-sealing bolts.

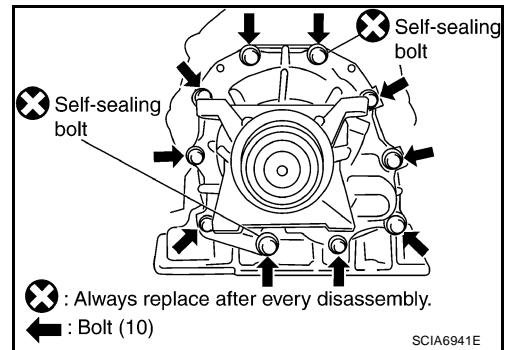

b. **4WD models**

i. Install gasket onto transmission case.

**CAUTION:**

- Completely remove all moisture, oil, old gasket and any foreign material from the transmission case and adapter case assembly mating surfaces.

- Do not reuse gasket.

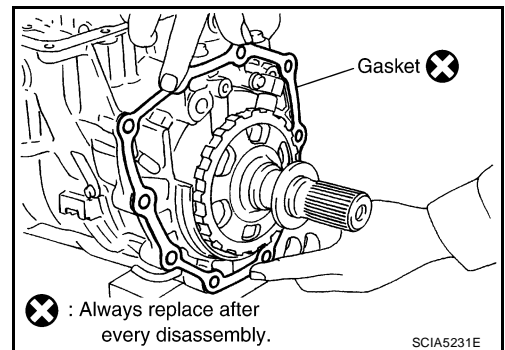

# ASSEMBLY

- ii. Install adapter case assembly to transmission case.

**CAUTION:**

Insert the tip of parking rod between the parking pawl and the parking actuator support when assembling the rear extension assembly.

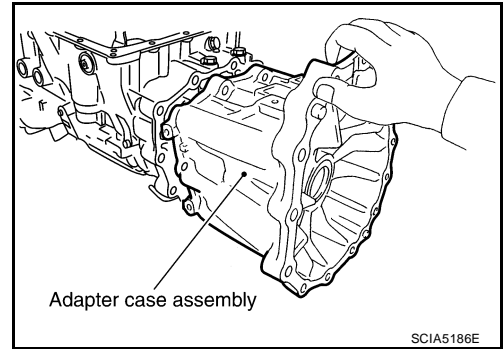

- iii. Install the bracket (2) and adapter case assembly bolts (1) and tighten to the specified torque.

**Adapter case assembly bolt** : 52 N·m (5.3 kg-m, 38 ft-lb)

**Self-sealing bolt** : 61 N·m (6.2 kg-m, 45 ft-lb)

**CAUTION:**

Do not reuse self-sealing bolt (3).

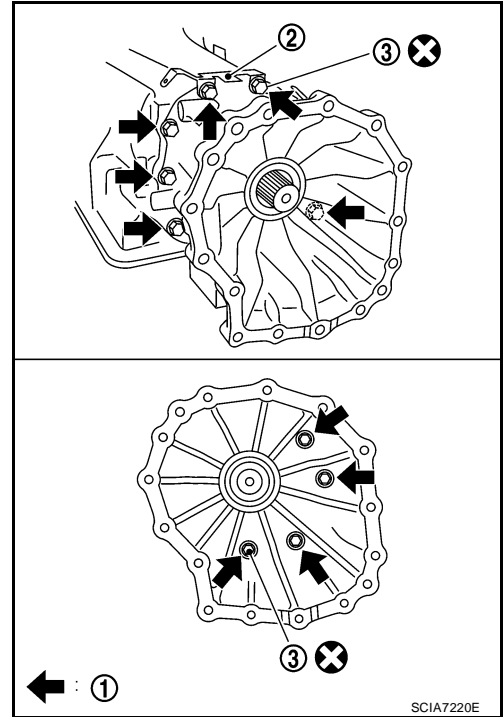

37. Install direct clutch assembly in reverse brake.

**CAUTION:**

Make sure that drum support edge surface and direct clutch inner boss edge surface come to almost same place.

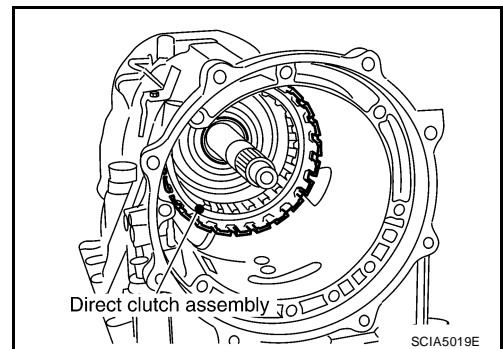

38. Install needle bearing in drum support.

**CAUTION:**

Apply petroleum jelly to needle bearing.

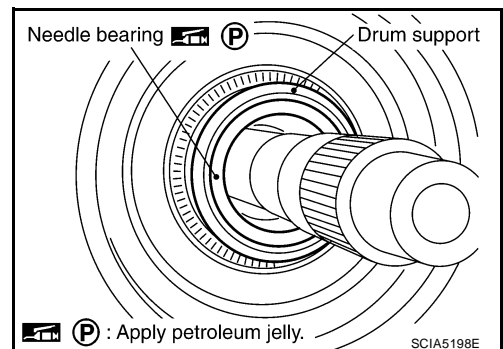

# ASSEMBLY

39. Install high and low reverse clutch assembly in direct clutch.

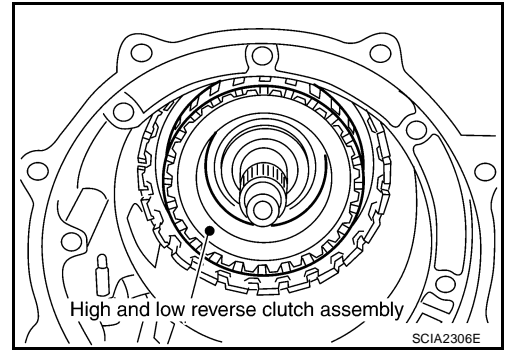

40. Align the drive plate using suitable tool.

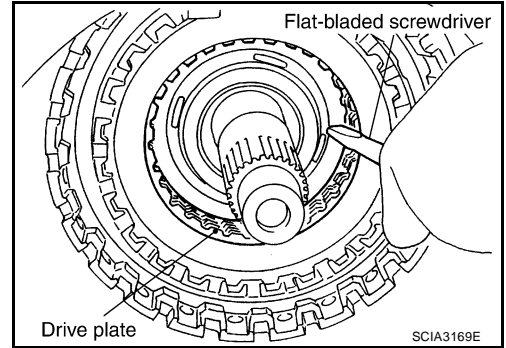

41. Install high and low reverse clutch hub, mid sun gear assembly and rear sun gear assembly as a unit.

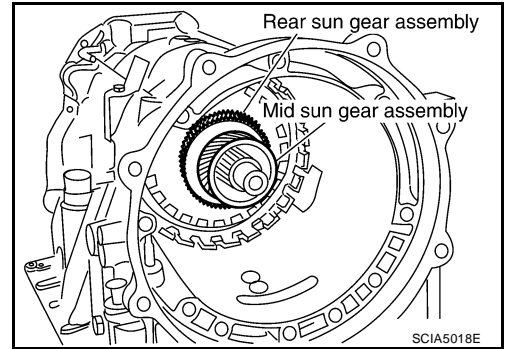

**CAUTION:**

Make sure that portion "A" of high and low reverse clutch drum protrudes approximately 2 mm (0.08 in) beyond portion "B" of rear sun gear.

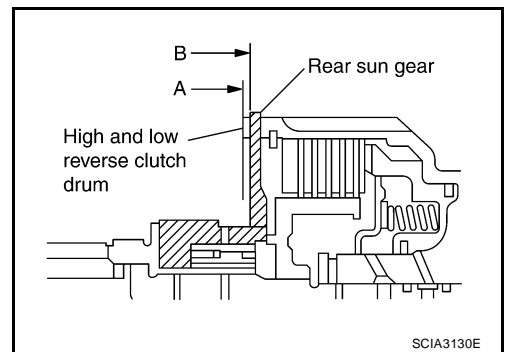

A  
B  
AT  
D  
E  
F  
G  
H  
I  
J  
K  
L  
M

# ASSEMBLY

42. Install needle bearing in rear carrier assembly.

**CAUTION:**  
Apply petroleum jelly to needle bearing.

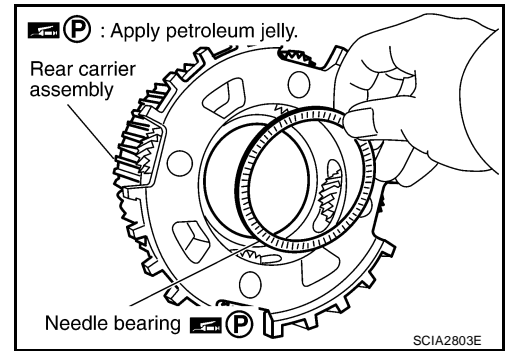

43. Install bearing race in rear carrier assembly.

**CAUTION:**  
Apply petroleum jelly to bearing race.

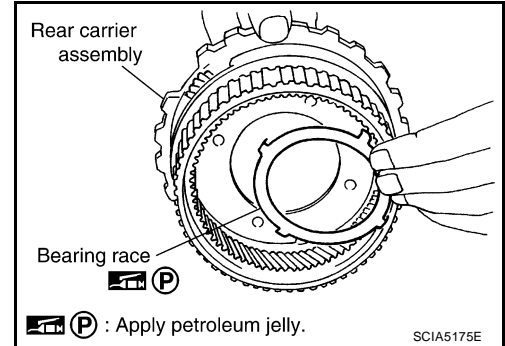

44. Install rear carrier assembly in direct clutch drum.

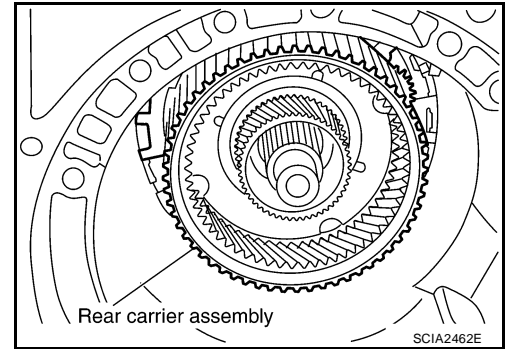

45. Install needle bearing (rear side) to mid carrier assembly.

**CAUTION:**  
Apply petroleum jelly to needle bearing.

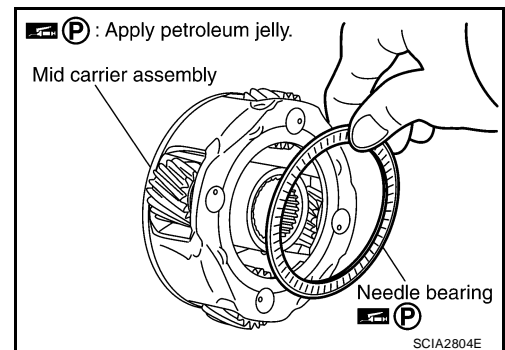

46. Install needle bearing (front side) to mid carrier assembly.

**CAUTION:**  
Apply petroleum jelly to needle bearing.

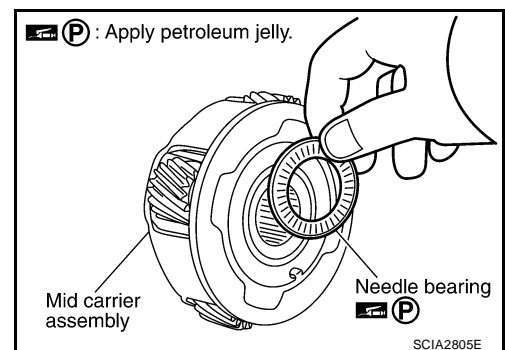

# ASSEMBLY

47. Install mid carrier assembly in rear carrier assembly.

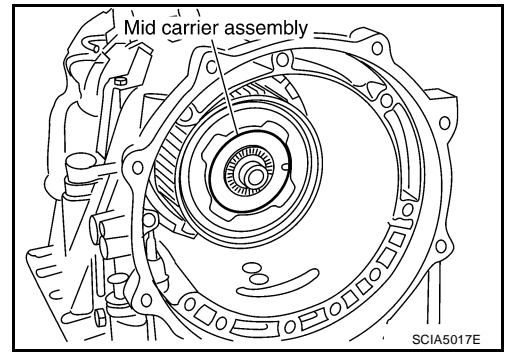

48. Install front carrier assembly, input clutch assembly and rear internal gear as a unit.

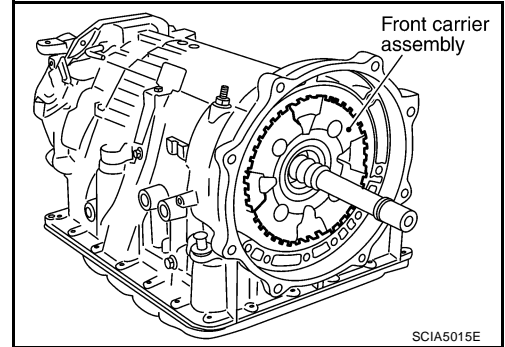

49. Install seal rings in input clutch assembly.

**CAUTION:**

- Do not reuse seal rings.
- Apply petroleum jelly to seal rings.

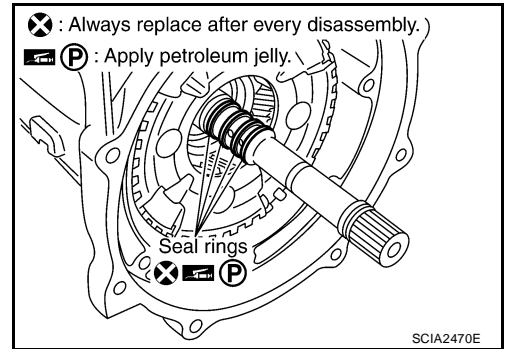

50. Install band servo anchor end pin and lock nut in transmission case.

**CAUTION:**

**Do not reuse band servo anchor end pin.**

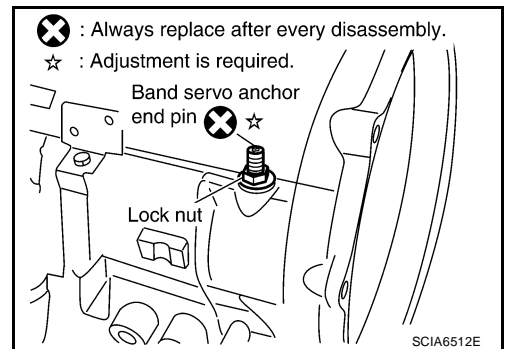

51. Install brake band in transmission case.

**CAUTION:**

**Install it so that the identification to avoid incorrect installation faces the servo side.**

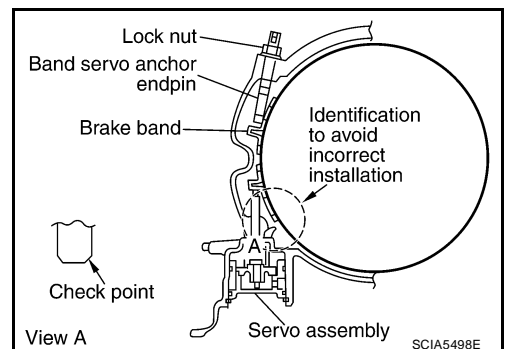

A  
B  
AT  
D  
E  
F  
G  
H  
I  
J  
K  
L  
M

# ASSEMBLY

52. Install front sun gear to front carrier assembly.

**CAUTION:**

Apply ATF to front sun gear bearing and 3rd one-way clutch end bearing.

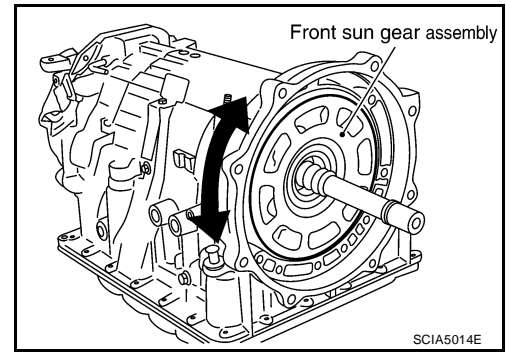

53. Install needle bearing to front sun gear.

**CAUTION:**

Apply petroleum jelly to needle bearing.

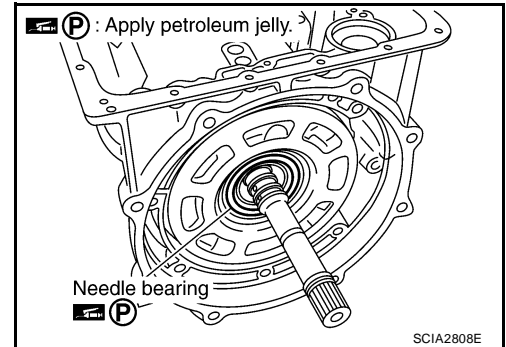

54. Adjust brake band tilting using a clip so that brake band contacts front sun gear drum evenly.

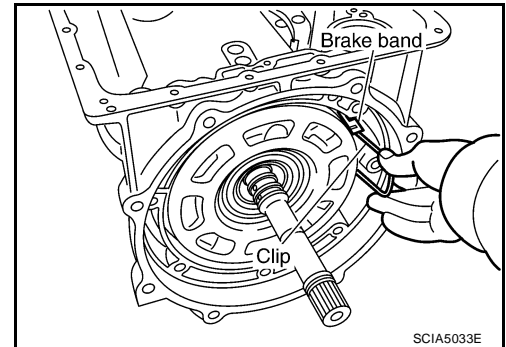

55. Adjust brake band.

- a. Loosen lock nut.
- b. Tighten band servo anchor end pin to specified torque.

**Anchor end pin : 5.0 N·m (0.51 kg·m, 44 in·lb)**

- c. Back of band servo anchor end pin three turns.
- d. Holding band servo anchor end pin, tighten lock nut to specified torque.

**Lock nut : 46 N·m (4.7 kg·m, 34 ft·lb)**

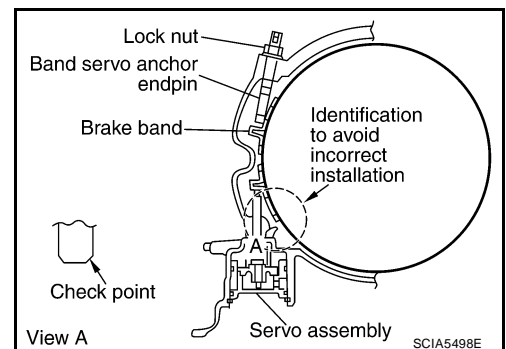



# ASSEMBLY

## Adjustment TOTAL END PLAY

UCS0049A

- Measure clearance between front sun gear and bearing race for oil pump cover.
- Select proper thickness of bearing race so that end play is within specifications.

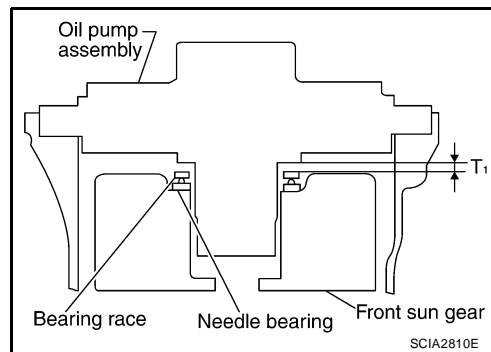

1. Measure dimensions "K" and "L" and then calculate dimension "J".

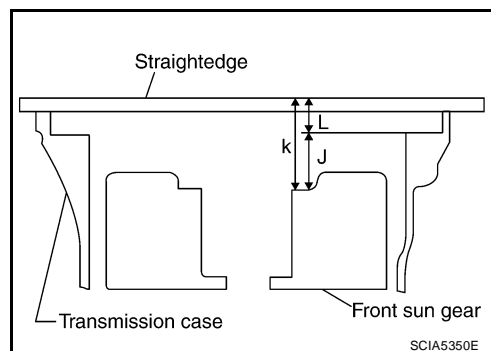

- a. Measure dimension "K".

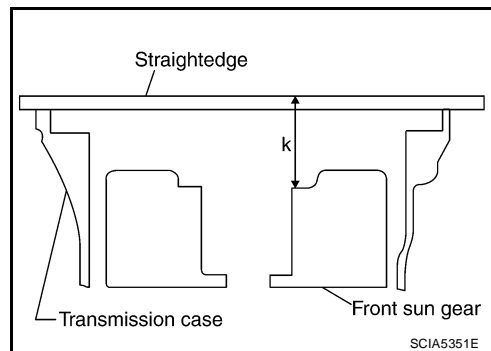

- b. Measure dimension "L".
- c. Calculate dimension "J".

**"J": Distance between oil pump fitting surface of transmission case and needle bearing mating surface of front sun gear.**

$$J = K - L$$

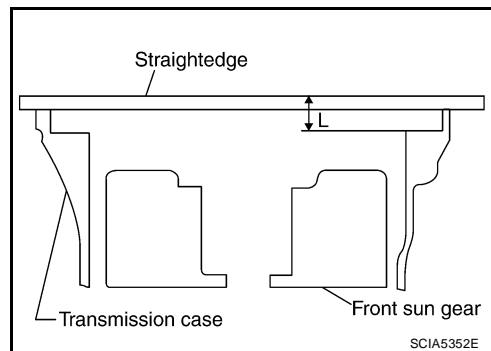

# ASSEMBLY

2. Measure dimensions "M1 " and "M2 " and then calculate dimension "M".

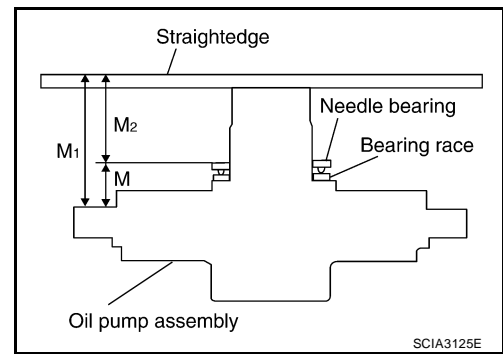

- a. Place bearing race and needle bearing on oil pump assembly.

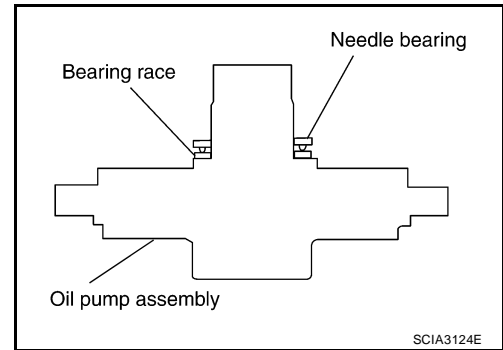

- b. Measure dimension "M1 ".

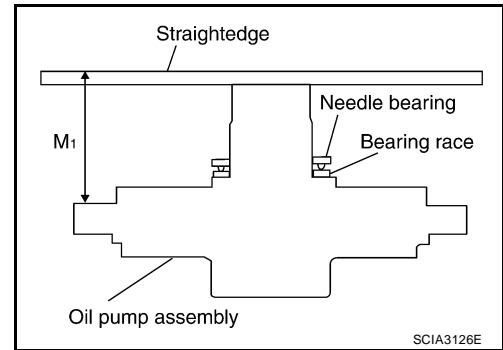

- c. Measure dimension "M2 ".

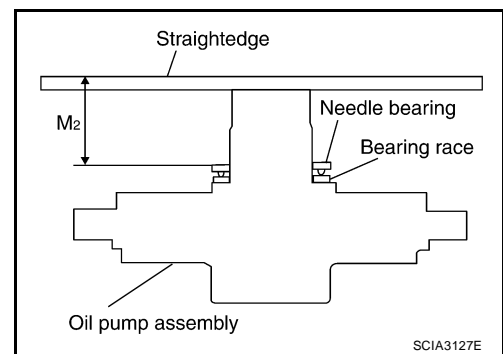

- d. Calculate dimension "M".

**"M": Distance between transmission case fitting surface of oil pump and needle bearing on oil pump.**

$$M = M1 - M2$$

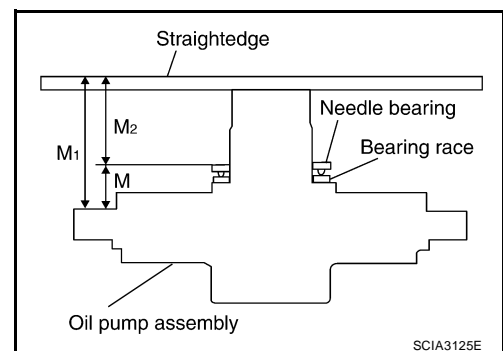

# ASSEMBLY

3. Adjust total end play "T1".

$$T_1 = J - M$$

Total end play "T1" : 0.25 - 0.55 mm (0.0098 - 0.0217 in)

- Select proper thickness of bearing race so that total end play is within specifications.

Bearing races Refer to [AT-333, "BEARING RACE FOR ADJUSTING TOTAL END PLAY"](#).

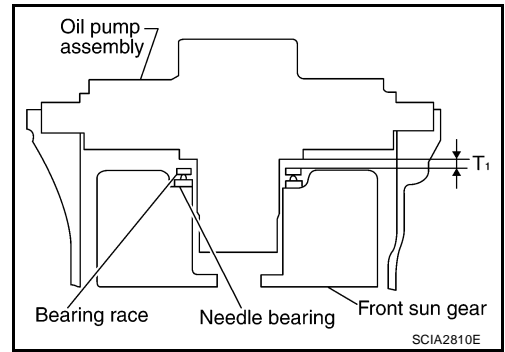

## Assembly (2)

1. Install O-ring to oil pump assembly.

### CAUTION:

- Do not reuse O-ring.
- Apply ATF to O-ring.

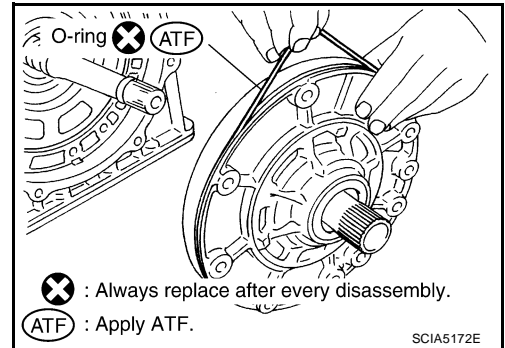

2. Install bearing race to oil pump assembly.

### CAUTION:

Apply petroleum jelly to bearing race.

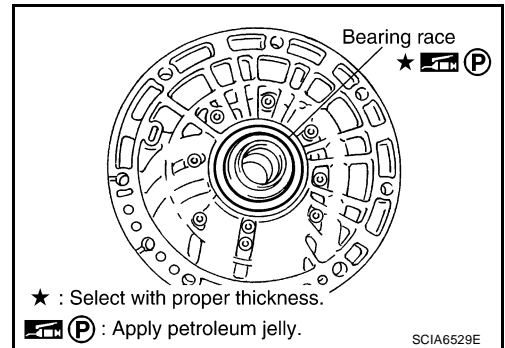

3. Install oil pump assembly in transmission case.

### CAUTION:

Apply ATF to oil pump bearing.

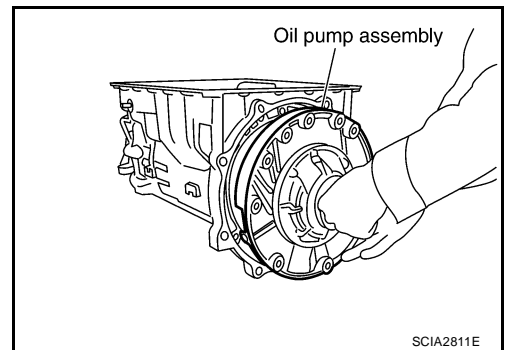

# ASSEMBLY

4. Apply recommended sealant (Genuine RTV Silicone Sealant or equivalent. Refer to [GI-47, "Recommended Chemical Products and Sealants"](#) .) to oil pump assembly as shown.

**CAUTION:**

Completely remove all moisture, oil, old sealant and any foreign material from the oil pump bolts and oil pump bolt mating surfaces.

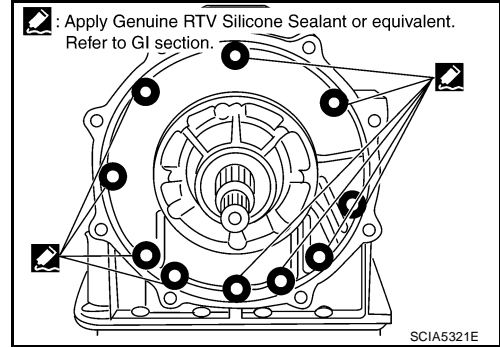

5. Tighten oil pump bolts to specified torque.

**Oil pump bolts : 48 N-m (4.9 kg-m, 35 ft-lb)**

**CAUTION:**

Apply ATF to oil pump bushing.

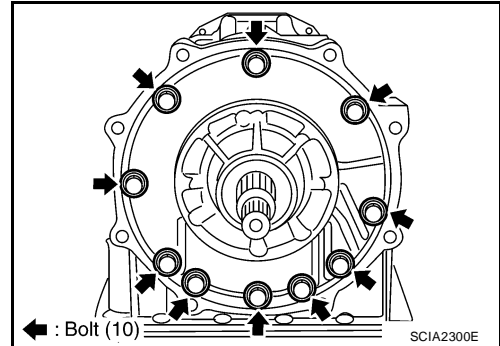

6. Install O-ring to input clutch assembly.

**CAUTION:**

- Do not reuse O-ring.
- Apply ATF to O-ring.

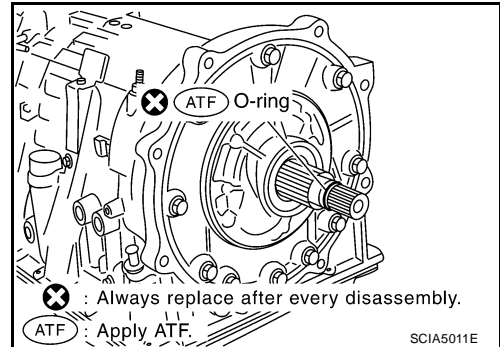

7. Install converter housing to transmission case and tighten bolts to specified torque.

**Converter housing bolt : 52 N-m (5.3 kg-m, 38 ft-lb)**

**Self-sealing bolt (A) : 61 N-m (6.2 kg-m, 45 ft-lb)**

**CAUTION:**

Do not reuse self-sealing bolt (A).

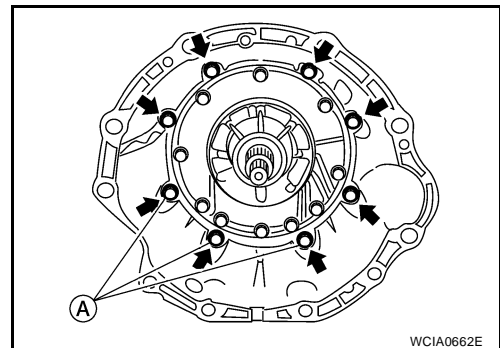

8. Make sure that brake band does not block turbine revolution sensor hole.

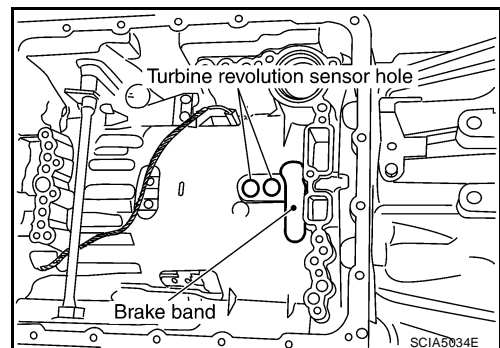

# ASSEMBLY

9. Install control valve with TCM.

a. Connect TCM connector and park/neutral position switch connector.

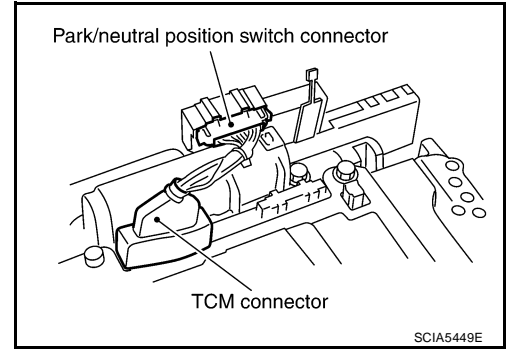

b. Install A/T assembly harness connector to control valve with TCM.

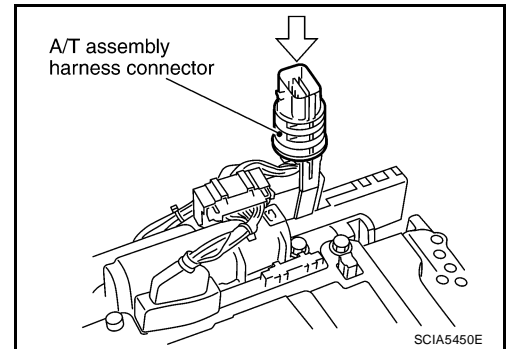

c. Connect TCM connectors.

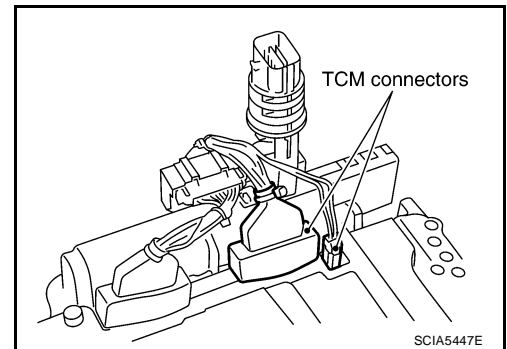

d. Install O-ring to A/T assembly harness connector.

**CAUTION:**

- Do not reuse O-ring.
- Apply ATF to O-ring.

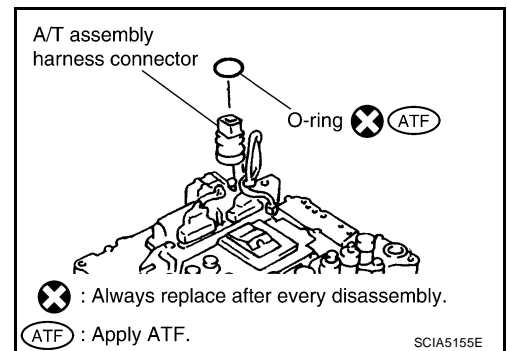

A  
B  
AT  
D  
E  
F  
G  
H  
I  
J  
K  
L  
M

# ASSEMBLY

e. Install A/T fluid temperature sensor 2 to bracket.

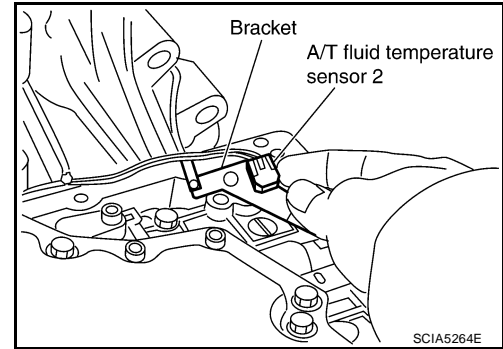

f. Install A/T fluid temperature sensor 2 (with bracket) to control valve with TCM and tighten bolt to specified torque.

**Bracket bolt : 7.9 N-m (0.81 kg-m, 70 in-lb)**

**CAUTION:**  
Adjust bolt hole of bracket to bolt hole of control valve.

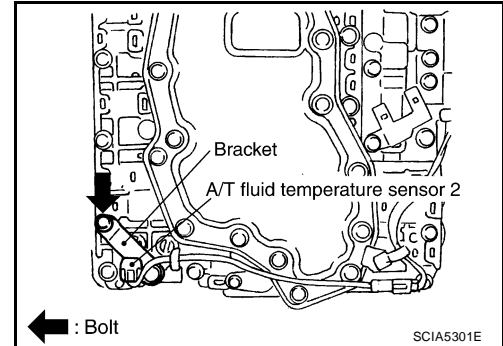

g. Install control valve with TCM in transmission case.

- CAUTION:**
- Make sure that turbine revolution sensor is securely installed into turbine revolution sensor hole.
  - Hang down revolution sensor harness toward outside so as not to disturb installation of control valve with TCM.
  - Adjust A/T assembly harness connector of control valve with TCM to terminal hole of transmission case.

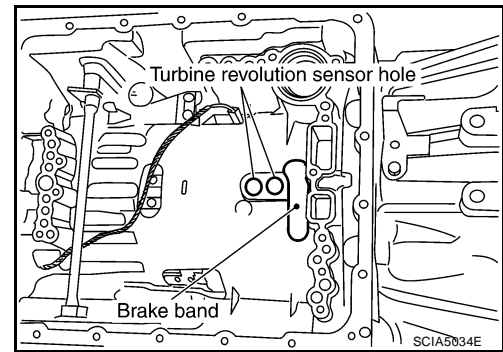

- Assemble it so that manual valve cutout is engaged with manual plate projection.

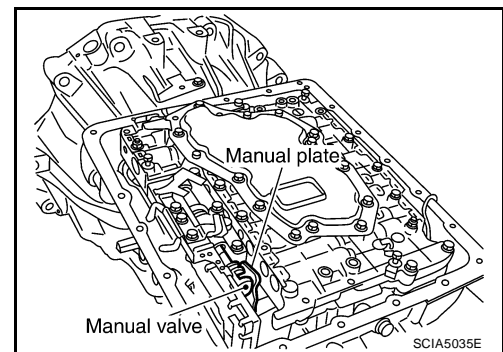

h. Install bolts (A), (B) and (C) to control valve with TCM.

Bolt symbol	Length mm (in)	Number of bolts
A	42 (1.65)	5
B	55 (2.17)	6
C	40 (1.57)	1

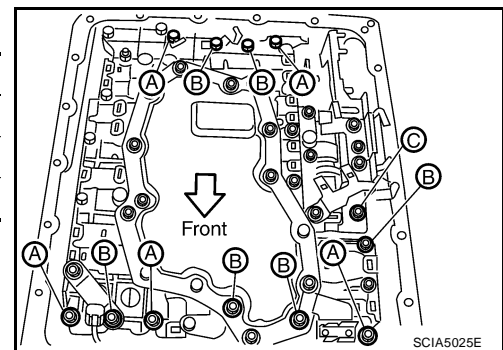

# ASSEMBLY

- i. Tighten bolts (1), (2) and (3) temporarily to prevent dislocation. After that tighten them in order (1 → 2 → 3), and then tighten other bolts.

**Bolts : 7.9 N·m (0.81 kg·m, 70 in·lb)**

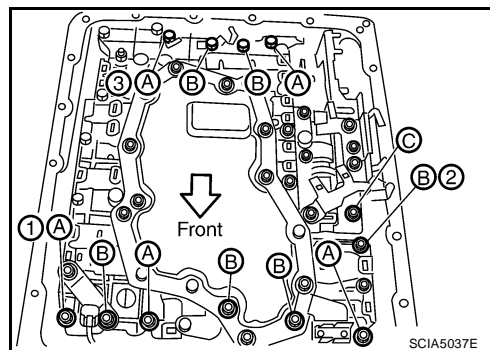

10. Connect A/T fluid temperature sensor 2 connector.  
11. Securely fasten terminal cord assembly and A/T fluid temperature sensor 2 harness with terminal clips.

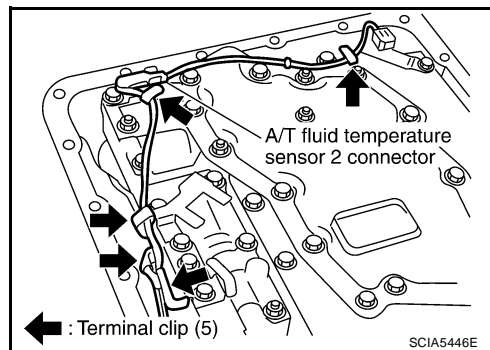

12. Connect revolution sensor connector.  
13. Securely fasten revolution sensor harness with terminal clip.

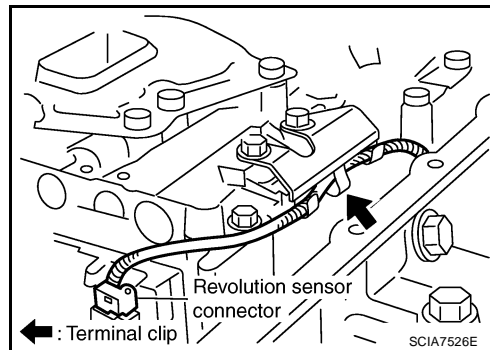

14. Pull down A/T assembly harness connector.

**CAUTION:**  
**Do not damage connector.**

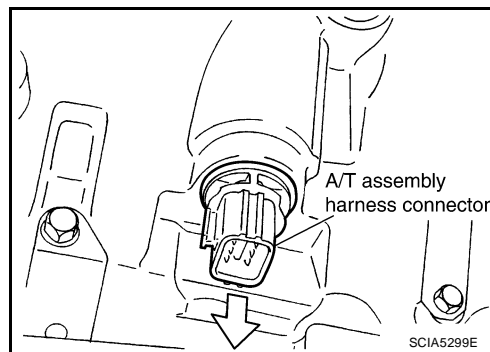

15. Install snap ring to A/T assembly harness connector.

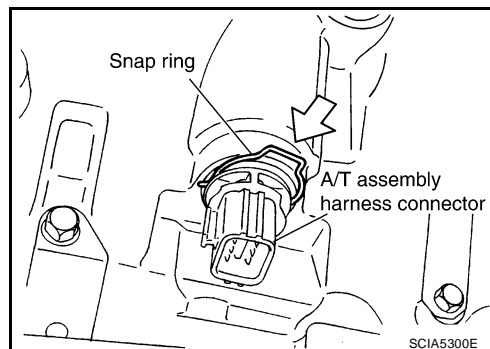

A  
B  
AT

D  
E  
F  
G

H  
I  
J  
K

L  
M

# ASSEMBLY

16. Install magnets in oil pan.

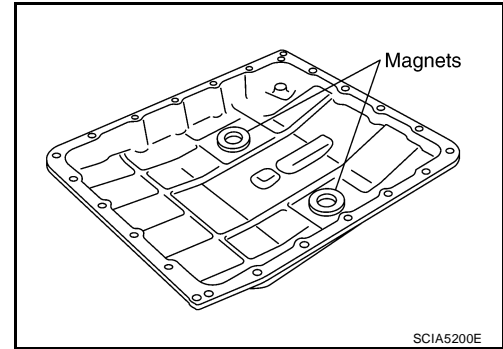

17. Install oil pan to transmission case.

a. Install oil pan gasket to transmission case.

**CAUTION:**

- Do not reuse oil pan gasket.
- Install it in the direction to align hole positions.
- Completely remove all moisture, oil and old gasket from oil pan gasket mating surface.

b. Install oil pan to transmission case.

**CAUTION:**

- Install it so that drain plug comes to the position as shown.
- Do not pinch harnesses.
- Completely remove all moisture, oil and old gasket from oil pan gasket mating surface.

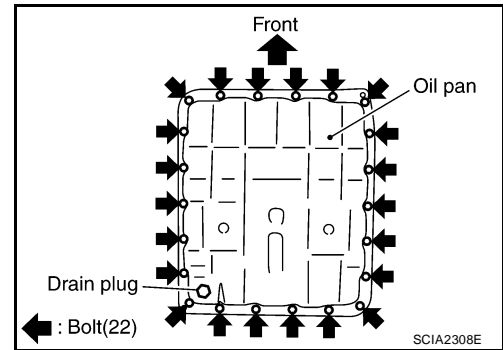

c. Tighten oil pan bolts to the specified torque in numerical order shown after temporarily tightening them.

**CAUTION:**

**Do not reuse oil pan bolts.**

**Oil pan bolts : 7.9 N·m (0.81 kg-m, 70 in-lb)**

18. Install drain plug to oil pan.

**CAUTION:**

**Do not reuse drain plug gasket.**

**Drain plug : 34 N·m (3.5 kg-m, 25 ft-lb)**

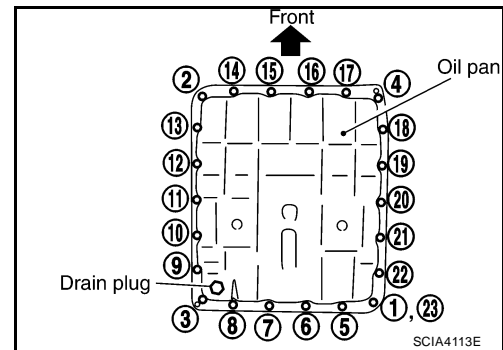

19. Install torque converter.

a. Pour ATF into torque converter.

- Approximately 2 liter (2-1/8 US qt, 1-3/4 Imp qt) of fluid is required for a new torque converter.
- When reusing old torque converter, add the same amount of fluid as was drained.

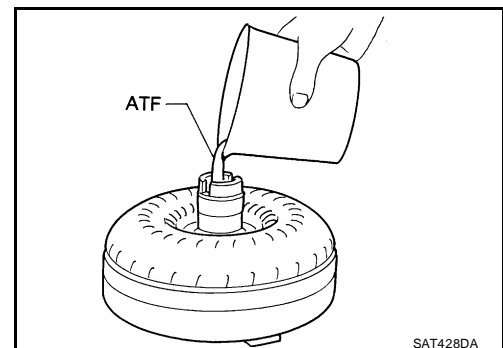



# ASSEMBLY

- b. Install torque converter while aligning notches of torque converter with notches of oil pump.

**CAUTION:**

**Install torque converter while rotating it.**

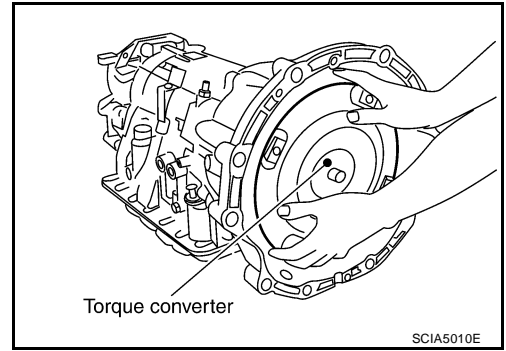

- c. Measure distance "A" to make sure that torque converter is in proper position.

**Distance "A" :25.0 mm (0.98 in) or more**

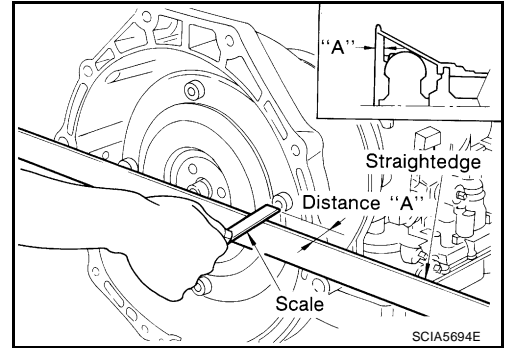

A  
B  
AT  
D  
E  
F  
G  
H  
I  
J  
K  
L  
M

# SERVICE DATA AND SPECIFICATIONS (SDS)

## SERVICE DATA AND SPECIFICATIONS (SDS)

PF0:00030

### General Specifications

UCS0049C

Applied model		QR25DE	VQ40DE	
		2WD		4WD
Automatic transmission model		RE5R05A		
Transmission model code number		97X9E	98X0A	98X0B
Stall torque ratio		1.76: 1		
Transmission gear ratio	1st	3.842		
	2nd	2.353		
	3rd	1.529		
	4th	1.000		
	5th	0.839		
	Reverse	2.764		
Recommended fluid		Genuine NISSAN Matic J ATF*1		
Fluid capacity		10.3 liter (10-7/8 US qt, 9-1/8 Imp qt)		

**CAUTION:**

- Use only Genuine NISSAN Matic J ATF. Do not mix with other fluid.
- Using automatic transmission fluid other than Genuine NISSAN Matic J ATF will deteriorate in driveability and automatic transmission durability, and may damage the automatic transmission, which is not covered by the warranty.

\*1: Refer to [MA-11, "Fluids and Lubricants"](#) .

### Vehicle Speed at Which Gear Shifting Occurs 2WD MODELS

UCS0049D

A/T model code number		97X9E							
Tire size	Throttle position	Vehicle speed km/h (MPH)							
		D1 →D2	D2 →D3	D3 →D4	D4 →D5	D5 →D4	D4 →D3	D3 →D2	D2 →D1
P235/75R15 P265/70R16	Full throttle	49 - 53 (30 - 33)	80 - 88 (50 - 55)	125-135 (78 - 84)	194 - 204 (121 - 127)	190 - 200 (118 - 124)	115 - 125 (72 - 78)	69 - 77 (43 - 48)	32 - 36 (20 - 23)
	Half throttle	36 - 40 (23 - 25)	59 - 65 (37 - 44)	91 - 99 (57 - 62)	128 - 136 (80 - 84)	99 - 107 (62 - 66)	63 - 71 (39 - 44)	44 - 50 (27 - 30)	11 - 15 (7 - 9)

- At half throttle, the accelerator opening is 1/2 of the full opening.

### 2WD MODELS

A/T model code number			98X0A							
Final gear ratio	Tire size	Throt-tle posi-tion	Vehicle speed km/h (MPH)							
			D1 →D2	D2 →D3	D3 →D4	D4 →D5	D5 →D4	D4 →D3	D3 →D2	D2 →D1
2.937	P265/70R16 P265/65R17	Full throttle	66 - 74 (41 - 46)	108 - 118 (68 - 74)	166 - 182 (104 - 114)	242 - 266 (151 - 166)	238 - 262 (149 - 164)	154 - 170 (96 - 106)	94 - 104 (59 - 65)	42 - 48 (26 - 30)
		Half throttle	53 - 59 (33 - 37)	86 - 96 (54 - 60)	134 - 149 (84 - 93)	158 - 174 (99 - 109)	125 - 137 (78 - 86)	79 - 85 (49 - 53)	54 - 61 (34 - 38)	12 - 14 (7 - 9)
3.133	P265/75R16	Full throttle	66 - 74 (41 - 46)	108 - 118 (68 - 74)	166 - 182 (104 - 114)	242 - 266 (151 - 166)	238 - 262 (149 - 164)	154 - 170 (96 - 106)	94 - 104 (59 - 65)	42 - 48 (26 - 30)
		Half throttle	53 - 59 (33 - 37)	86 - 96 (54 - 60)	134 - 149 (84 - 93)	158 - 174 (99 - 109)	125 - 138 (78 - 86)	79 - 86 (49 - 53)	54 - 61 (34 - 38)	12 - 14 (7 - 9)
	P265/70R16 P265/65R17	Full throttle	60 - 68 (37 - 43)	99 - 110 (61 - 69)	153 - 170 (95 - 107)	234 - 259 (146 - 162)	230 - 255 (143 - 160)	142 - 158 (88 - 99)	87 - 97 (54 - 61)	41 - 47 (25 - 30)
		Half throttle	49 - 55 (30 - 35)	80 - 90 (50 - 57)	123 - 137 (76 - 86)	149 - 165 (93 - 103)	115 - 128 (71 - 80)	71 - 79 (44 - 50)	51 - 57 (31 - 36)	12 - 14 (7 - 9)

- At half throttle, the accelerator opening is 1/2 of the full opening.

# SERVICE DATA AND SPECIFICATIONS (SDS)

## 4WD MODELS

A/T model code number			98X0B							
Final gear ratio	Tire size	Throttle position	Vehicle speed km/h (MPH)							
			D1 →D2	D2 →D3	D3 →D4	D4 →D5	D5 →D4	D4 →D3	D3 →D2	D2 →D1
3.133	P265/70R16	Full throttle	60 - 68 (37 - 43)	99 - 110 (61 - 69)	153 - 170 (95 - 107)	234 - 259 (146 - 162)	230 - 255 (143 - 160)	142 - 158 (88 - 99)	87 - 97 (54 - 61)	41 - 47 (25 - 30)
	P265/65R17	Half throttle	49 - 55 (30 - 35)	80 - 90 (50 - 57)	123 - 137 (76 - 86)	149 - 165 (93 - 103)	115 - 128 (71 - 80)	71 - 79 (44 - 50)	51 - 57 (31 - 36)	12 - 14 (7 - 9)
3.357	P265/75R16	Full throttle	60 - 68 (37 - 43)	99 - 110 (61 - 69)	153 - 170 (95 - 107)	234 - 259 (146 - 162)	230 - 255 (143 - 160)	142 - 158 (88 - 99)	87 - 97 (54 - 61)	41 - 47 (25 - 30)
		Half throttle	49 - 55 (30 - 35)	80 - 90 (50 - 57)	123 - 137 (76 - 86)	149 - 165 (93 - 103)	115 - 128 (71 - 80)	71 - 79 (44 - 50)	51 - 57 (31 - 36)	12 - 14 (7 - 9)
	P265/70R16 P265/65R17	Full throttle	58 - 65 (36 - 41)	94 - 104 (58 - 65)	144 - 160 (90 - 100)	221 - 245 (138 - 154)	218 - 241 (136 - 151)	135 - 150 (84 - 94)	82 - 92 (51 - 58)	40 - 45 (25 - 29)
		Half throttle	46 - 52 (28 - 33)	76 - 84 (47 - 53)	117 - 130 (73 - 82)	140 - 156 (88 - 98)	109 - 121 (68 - 76)	67 - 75 (41 - 47)	48 - 54 (30 - 34)	12 - 14 (7 - 9)

- At half throttle, the accelerator opening is 1/2 of the full opening.

## Vehicle Speed at Which Lock-up Occurs/Releases

UCS0049E

### 2WD MODELS

A/T model code number		97X9E	
Tire size	Throttle position	Vehicle speed km/h (MPH)	
		Lock-up "ON"	Lock-up "OFF"
P235/75R15 P265/70R16	Closed throttle	56 - 64 (35 - 40)	53 - 61 (33 - 37)
	Half throttle	161 - 169 (101 - 106)	126 - 134 (78 - 83)

- At closed throttle, the accelerator opening is less than 1/8 condition. (Closed throttle position signal: OFF)
- At half throttle, the accelerator opening is 1/2 of the full opening.

### 2WD MODELS

A/T model code number			98X0A	
Final gear ratio	Tire size	Throttle position	Vehicle speed km/h (MPH)	
			Lock-up "ON"	Lock-up "OFF"
2.937	P265/70R16 P265/65R17	Closed throttle	71 - 79 (44 - 49)	68 - 76 (43 - 48)
		Half throttle	175 - 195 (109 - 122)	144 - 160 (90 - 100)
3.133	P265/75R16	Closed throttle	71 - 79 (44 - 49)	68 - 76 (43 - 48)
		Half throttle	175 - 195 (109 - 122)	144 - 160 (90 - 100)
	P265/70R16 P265/65R17	Closed throttle	66 - 74 (41 - 46)	63 - 71 (39 - 44)
		Half throttle	166 - 186 (104 - 116)	132 - 148 (83 - 93)

- At closed throttle, the accelerator opening is less than 1/8 condition. (Closed throttle position signal: OFF)
- At half throttle, the accelerator opening is 1/2 of the full opening.

# SERVICE DATA AND SPECIFICATIONS (SDS)

## 4WD MODELS

A/T model code number			98X0B	
Final gear ratio	Tire size	Throttle position	Vehicle speed km/h (MPH)	
			Lock-up "ON"	Lock-up "OFF"
3.133	P265/70R16	Closed throttle	66 - 74 (41 - 46)	63 - 71 (39 - 44)
	P265/65R17	Half throttle	166 - 186 (104 - 116)	132 - 148 (76 - 93)
3.357	P265/75R16	Closed throttle	66 - 74 (41 - 46)	63 - 71 (39 - 44)
		Half throttle	166 - 186 (104 - 116)	132 - 148 (76 - 93)
	P265/70R16 P265/65R17	Closed throttle	62 - 70 (39 - 44)	59 - 67 (37 - 42)
		Half throttle	157 - 175 (98 - 109)	126 - 140 (79 - 88)

- At closed throttle, the accelerator opening is less than 1/8 condition. (Closed throttle position signal: OFF)
- At half throttle, the accelerator opening is 1/2 of the full opening.

## Stall Speed

UCS0049F

Engine model	QR25DE	VQ40DE
Stall speed	2,350 - 2,650 rpm	2,200 - 2,500 rpm

## Line Pressure

UCS0049G

Engine speed	Line pressure [kPa (kg/cm <sup>2</sup> , psi)]	
	"R" position	"D" position
At idle speed	425 - 465 (4.3 - 4.7, 62 - 67)	379 - 428 (3.9 - 4.4, 55 - 62)
At stall speed	1,605 - 1,950 (16.4 - 19.9, 233 - 283)	1,310 - 1,500 (13.4 - 15.3, 190 - 218)

## A/T Fluid Temperature Sensor

UCS0049H

Name	Condition	CONSULT-II "DATA MONITOR" (Approx.) (V)	Resistance (Approx.) (kΩ)
A/T fluid temperature sensor 1	0°C (32°F)	3.3	15
	20°C (68°F)	2.7	6.5
	80°C (176°F)	0.9	0.9
A/T fluid temperature sensor 2	0°C (32°F)	3.3	10
	20°C (68°F)	2.5	4
	80°C (176°F)	0.7	0.5

## Turbine Revolution Sensor

UCS0049I

Name	Condition	Data (Approx.)
Turbine revolution sensor 1	When running at 50 km/h (31 MPH) in 4th speed with the closed throttle position signal "OFF".	1.3 (kHz)
Turbine revolution sensor 2	When moving at 20 km/h (12 MPH) in 1st speed with the closed throttle position signal "OFF".	

## Vehicle Speed Sensor A/T (Revolution Sensor)

UCS0049J

Name	Condition	Data (Approx.)
Revolution sensor	When moving at 20 km/h (12 MPH).	185 (Hz)

# SERVICE DATA AND SPECIFICATIONS (SDS)

## Reverse brake

UCS0049K

	Thickness mm (in)	Part number*
Thickness of retaining plates	4.2 (0.165)	31667 90X14
	4.4 (0.173)	31667 90X15
	4.6 (0.181)	31667 90X16
	4.8 (0.189)	31667 90X17
	5.0 (0.197)	31667 90X18
	5.2 (0.205)	31667 90X19

\*: Always check with the Parts Department for the latest parts information.

## Total End Play

UCS0049L

Total end play mm (in)	0.25 - 0.55 (0.0098 - 0.0217)
------------------------	-------------------------------

## BEARING RACE FOR ADJUSTING TOTAL END PLAY

Thickness mm (in)	Part number*
0.8 (0.031)	31435 95X00
1.0 (0.039)	31435 95X01
1.2 (0.047)	31435 95X02
1.4 (0.055)	31435 95X03
1.6 (0.063)	31435 95X04
1.8 (0.071)	31435 95X05

\*: Always check with the Parts Department for the latest parts information.

# SERVICE DATA AND SPECIFICATIONS (SDS)

---