

SECTION **FL**  
FUEL SYSTEM

A  
FL  
C  
D  
E  
F  
G  
H  
I  
J  
K  
L  
M

CONTENTS

<b>PRECAUTIONS</b> .....	<b>2</b>	<b>FUEL PUMP ASSEMBLY</b> .....	<b>6</b>
Precautions for Supplemental Restraint System (SRS) "AIR BAG" and "SEAT BELT PRE-TENSIONER" .....	2	Removal and Installation .....	6
<b>PREPARATION</b> .....	<b>3</b>	REMOVAL .....	7
Special Service Tools .....	3	INSTALLATION .....	9
Commercial Service Tool .....	3	INSPECTION AFTER INSTALLATION .....	9
<b>FUEL SYSTEM</b> .....	<b>4</b>	<b>FUEL TANK</b> .....	<b>11</b>
Checking Fuel Lines .....	4	Removal and Installation .....	11
General Precautions .....	4	REMOVAL .....	12
<b>FUEL LEVEL SENSOR UNIT, FUEL FILTER AND</b>		INSTALLATION .....	14
		INSPECTION AFTER INSTALLATION .....	14
		<b>SERVICE DATA AND SPECIFICATIONS (SDS)</b> .....	<b>16</b>
		Standard and Limit .....	16

# PRECAUTIONS

---

## PRECAUTIONS

PFP:00001

### Precautions for Supplemental Restraint System (SRS) “AIR BAG” and “SEAT BELT PRE-TENSIONER”

EBS0072J

The Supplemental Restraint System such as “AIR BAG” and “SEAT BELT PRE-TENSIONER”, used along with a front seat belt, helps to reduce the risk or severity of injury to the driver and front passenger for certain types of collision. This system includes seat belt switch inputs and dual stage front air bag modules. The SRS system uses the seat belt switches to determine the front air bag deployment, and may only deploy one front air bag, depending on the severity of a collision and whether the front occupants are belted or unbelted. Information necessary to service the system safely is included in the SRS and SB section of this Service Manual.

#### **WARNING:**

- To avoid rendering the SRS inoperative, which could increase the risk of personal injury or death in the event of a collision which would result in air bag inflation, all maintenance must be performed by an authorized NISSAN/INFINITI dealer.
- Improper maintenance, including incorrect removal and installation of the SRS, can lead to personal injury caused by unintentional activation of the system. For removal of Spiral Cable and Air Bag Module, see the SRS section.
- Do not use electrical test equipment on any circuit related to the SRS unless instructed to in this Service Manual. SRS wiring harnesses can be identified by yellow and/or orange harnesses or harness connectors.

# PREPARATION

## PREPARATION

PFP:00002

### Special Service Tools

EBS00M8N

The actual shapes of the Kent-Moore tools may differ from those of the special tools illustrated here.

Tool number (Kent-Moore No.) Tool name	Description
— (J-45722) 130 mm Lock ring tool	Removing and installing fuel tank lock ring

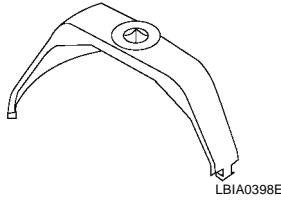

LBI A0398E

### Commercial Service Tool

EBS00M8O

Tool name	Description
Power tool	Loosening bolts and nuts

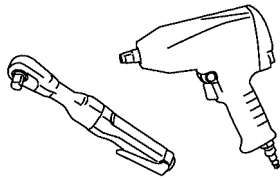

PBIC0190E

# FUEL SYSTEM

## FUEL SYSTEM

PFP:17503

### Checking Fuel Lines

EBS00M8P

Inspect fuel lines, fuel filler cap and fuel tank for improper attachment, leaks, cracks, damage, loose connections, chafing or deterioration.

If necessary, repair or replace damaged parts.

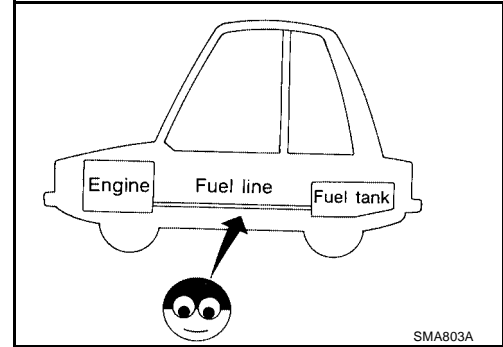

### General Precautions

EBS00M8Q

#### **WARNING:**

When replacing fuel line parts, be sure to observe the following.

- Put a "CAUTION: INFLAMMABLE" sign in the workshop.
- Be sure to work in a well ventilated area and furnish workshop with a CO<sub>2</sub> fire extinguisher.
- Do not smoke while servicing fuel system. Keep open flames and sparks away from the work area.

#### **CAUTION:**

- Use gasoline required by the regulations for octane number. Refer to [GI-5, "Precautions for Fuel"](#).
- Before removing fuel line parts, carry out the following procedures:
  - Put drained fuel in an explosion-proof container and put the lid on securely. Keep the container in safe area.
  - Release fuel pressure from the fuel lines. Refer to [EC-86, "FUEL PRESSURE RELEASE"](#) (QR), [EC-689, "FUEL PRESSURE RELEASE"](#) (VQ).
  - Disconnect the battery negative terminal.
- Always replace O-rings and clamps with new ones.
- Do not kink or twist hoses when they are being installed.
- Do not tighten hose clamps excessively to avoid damaging hoses.  
Tighten high-pressure rubber hose clamp so that clamp end is 3 mm (0.12 in) from hose end.  
Tightening torque specifications are the same for all rubber hose clamps.  
Ensure that screw does not contact adjacent parts.

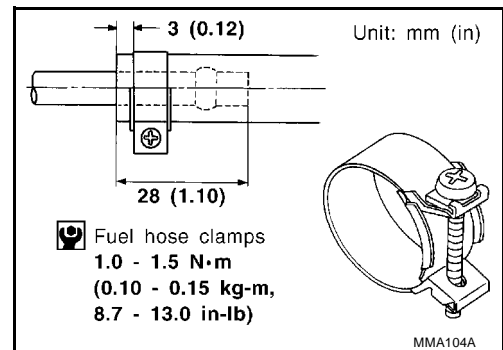

# FUEL SYSTEM

- After connecting the fuel tube quick connectors, make sure the quick connectors are secure. Ensure that the connector and resin tube do not contact any adjacent parts.
- After installing tubes, make sure there is no fuel leakage at connections in the following steps.
- Apply fuel pressure to fuel lines with turning ignition switch ON (with engine stopped). Then check for fuel leaks at connections.
- Start the engine and rev it up and check for fuel leaks at connections.
- Use only a Genuine NISSAN fuel filler cap as a replacement. If an incorrect fuel filler cap is used, the MIL may come on.
- For servicing "Evaporative Emission System" parts, refer to [EC-38, "EVAPORATIVE EMISSION SYSTEM" \(QR\)](#), [EC-641, "EVAPORATIVE EMISSION SYSTEM" \(VQ\)](#).
- For servicing "On Board Refueling Vapor Recovery (ORVR)" parts, refer to [EC-45, "ON BOARD REFUELING VAPOR RECOVERY \(ORVR\)" \(QR\)](#), [EC-648, "ON BOARD REFUELING VAPOR RECOVERY \(ORVR\)" \(VQ\)](#).

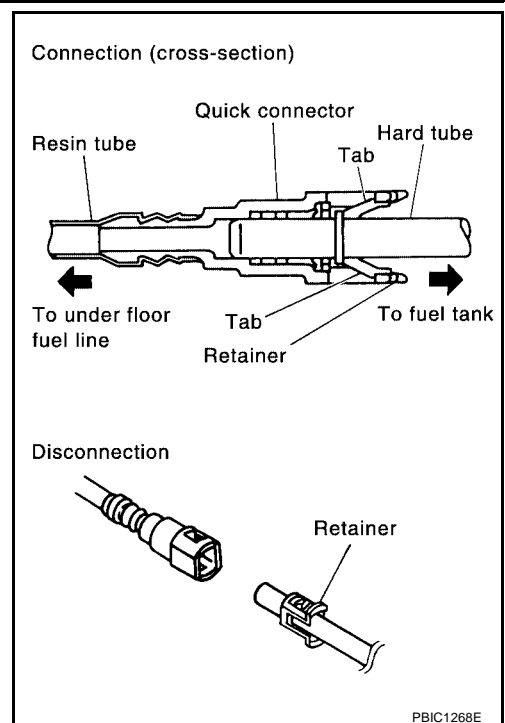

A

FL

C

D

E

F

G

H

I

J

K

L

M

# FUEL LEVEL SENSOR UNIT, FUEL FILTER AND FUEL PUMP ASSEMBLY

## FUEL LEVEL SENSOR UNIT, FUEL FILTER AND FUEL PUMP ASSEMBLY PFP:17042

### Removal and Installation

EBS00M8R

SEC. 172 • 500

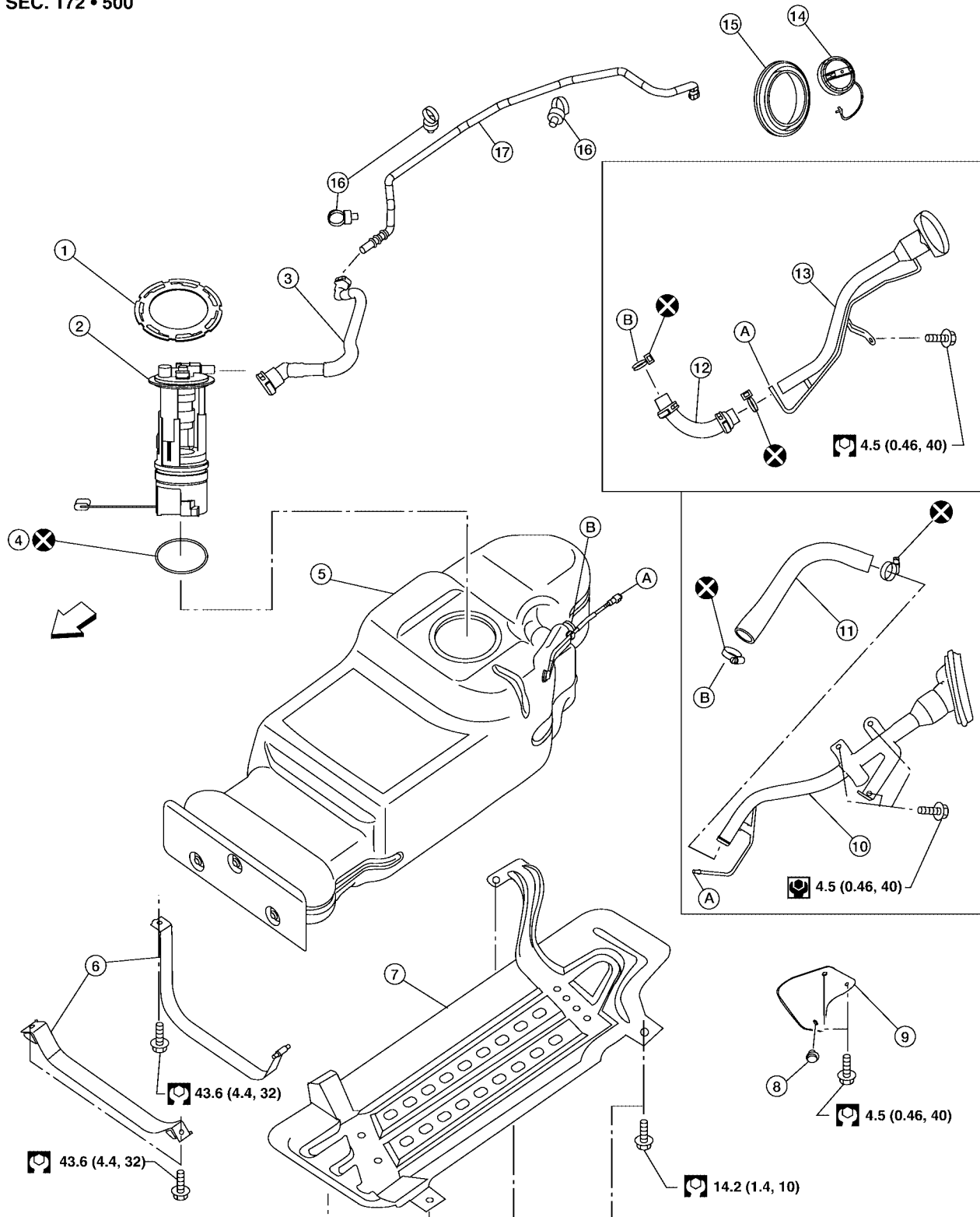

WBIA0732E

- |  |   |                            |
|--|---|----------------------------|
| 1. Lock ring   | 2. Fuel level sensor, fuel filter, and fuel pump assembly | 3. EVAP hose               |
| 4. Fuel level sensor, fuel filter, and fuel pump assembly O-ring | 5. Fuel tank  | 6. Fuel tank straps        |
| 7. Fuel tank shield  | 8. Clip   | 9. Fuel filler pipe shield |

# FUEL LEVEL SENSOR UNIT, FUEL FILTER AND FUEL PUMP ASSEMBLY

- |                                     |                        |                                |
|-------------------------------------|------------------------|--------------------------------|
| 10. Fuel filler pipe                | 11. Fuel filler hose   | 12. Fuel filler hose           |
| 13. Fuel filler pipe                | 14. Fuel filler cap    | 15. Fuel filler pipe grommet   |
| 16. Clamp                           | 17. EVAP canister hose | A. Fuel filler hose connection |
| B. Fuel filler hose vent connection | ← Front                |                                |

## REMOVAL

### WARNING:

Follow the "General Precautions" before working on the fuel system. Refer to [FL-4, "General Precautions"](#).

1. Remove the fuel filler cap to release the pressure from inside the fuel tank.
2. Remove the LH rear wheel and tire. Refer to [WT-7, "Rotation"](#).
3. Check the fuel level on level gauge. If the fuel gauge indicates more than the level as shown (full or almost full), drain the fuel from the fuel tank until the fuel gauge indicates the level as shown, or less.

### NOTE:

Fuel will be spilled when removing the fuel level sensor, fuel filter, and fuel pump assembly for the fuel level is above the fuel level sensor, fuel filter, and fuel pump assembly fuel tank opening.

- As a guide, the fuel level reaches the fuel gauge position as shown, or less, when approximately 15 ℓ (4 US gal, 3 1/4 Imp gal) of fuel are drained from the fuel tank.
  - If the fuel pump does not operate, use the following procedure to drain the fuel to the specified level.
- a. Insert a suitable hose of less than 15 mm (0.59 in) diameter into the fuel filler pipe through the fuel filler opening to drain the fuel from fuel filler pipe.
  - b. Remove the fuel filler pipe shield.
  - c. Disconnect the fuel filler hose from the fuel filler pipe.
  - d. Insert a suitable hose into the fuel tank through the fuel filler hose to drain the fuel from the fuel tank.
4. Release the fuel pressure from the fuel lines. Refer to [EC-86, "FUEL PRESSURE RELEASE"](#) (QR), [EC-689, "FUEL PRESSURE RELEASE"](#) (VQ).
  5. Disconnect the battery negative terminal.
  6. Remove the fuel tank shield.
  7. Remove the fuel tank strap bolts while supporting the fuel tank with a suitable lift jack.
  8. Lower the fuel tank using a suitable lift jack to access the top of the fuel level sensor, fuel filter, and fuel pump assembly.

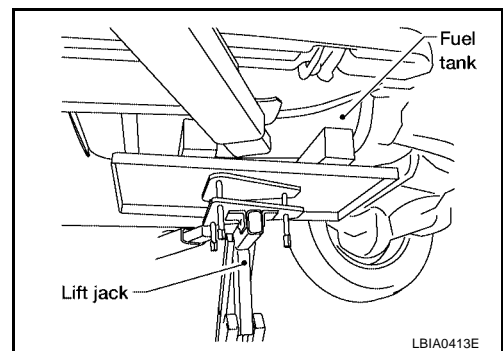
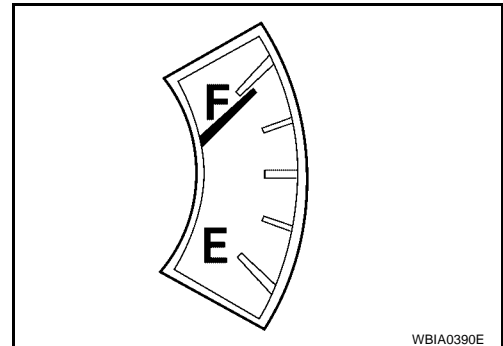

# FUEL LEVEL SENSOR UNIT, FUEL FILTER AND FUEL PUMP ASSEMBLY

9. Disconnect the fuel level sensor, fuel filter, and fuel pump assembly electrical connector, EVAP hose, and the fuel feed hose.
- Disconnect the fuel feed hose from the molded clip in the side of the fuel tank.

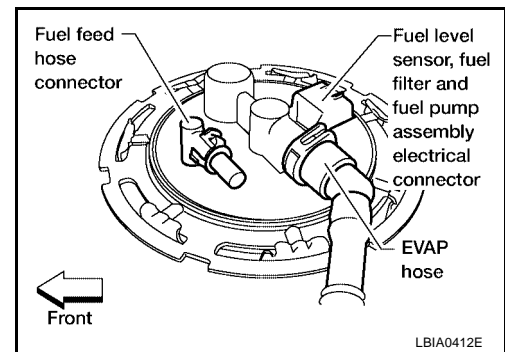

Disconnect the quick connector as follows:

- Hold the sides of the connector, push in tabs and pull out the tube.
- If the connector and the tube are stuck together, push and pull several times until they start to move. Then disconnect them by pulling.

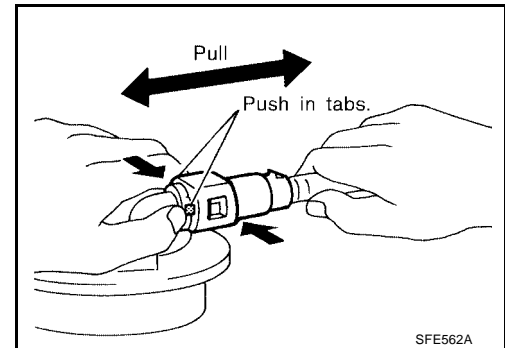

## CAUTION:

- The quick connector can be disconnected when the tabs are completely depressed. Do not twist the quick connector more than necessary.
- Do not use any tools to disconnect the quick connector.
- Keep the resin tube away from heat. Be especially careful when welding near the tube.
- Prevent any acid liquids such as battery electrolyte, from getting on the resin tube.
- Do not bend or twist the resin tube during connection.
- Do not remove the remaining retainer on the hard tube (or the equivalent) except when the resin tube or the retainer is replaced.
- When the resin tube or hard tube, or the equivalent, is replaced, also replace the retainer with a new one (semi-transparent retainer).

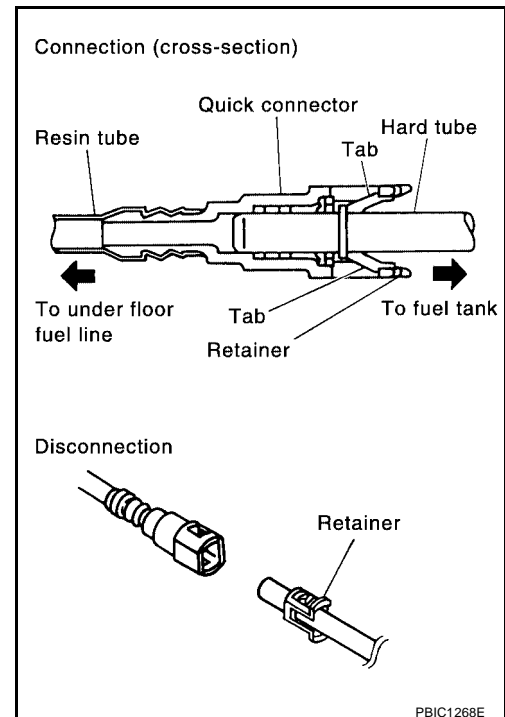



# FUEL LEVEL SENSOR UNIT, FUEL FILTER AND FUEL PUMP ASSEMBLY

- To keep the quick connector clean and to avoid damage and contamination from foreign materials, cover the quick connector with plastic bags or suitable material as shown.

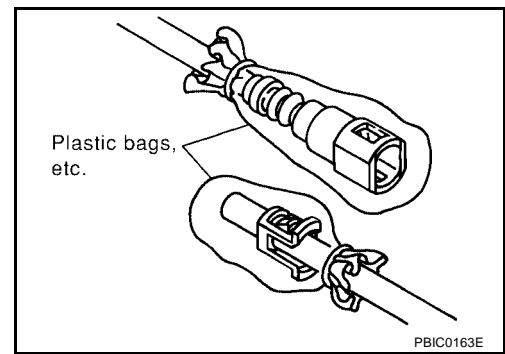

10. Lower the fuel tank using a suitable lift jack and remove it from the vehicle to access the fuel level sensor, fuel filter, and fuel pump assembly.

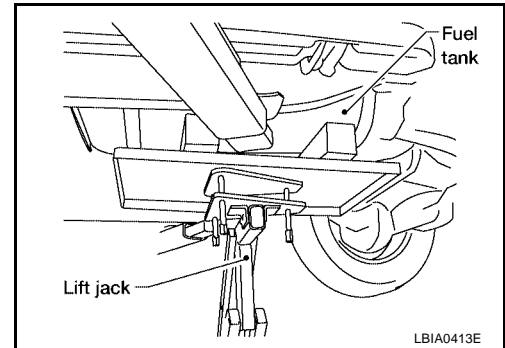

11. Remove the lock ring using Tool as shown.

**Tool number : — (J-45722)**

12. Disconnect the EVAP hose from the molded clip in the top of the fuel tank.
13. Remove the fuel level sensor, fuel filter, and fuel pump assembly. Remove and discard the fuel level sensor, fuel filter, and fuel pump assembly O-ring.

### CAUTION:

- Do not bend the float arm during removal.
- Avoid impacts such as dropping when handling the components.

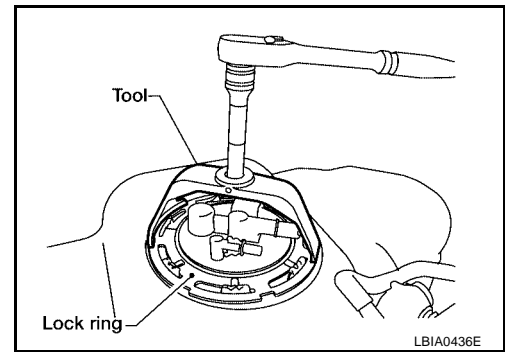

## INSTALLATION

Installation is in the reverse order of removal.

- For installation, use a new fuel level sensor, fuel filter, and fuel pump assembly O-ring.
- Connect the quick connector as follows:
  - Check the connection for any damage or foreign materials.
  - Align the connector with the pipe, then insert the connector straight into the pipe until a click is heard.
  - After connecting the quick connector, make sure that the connection is secure by checking as follows:
    - Pull the tube and the connector to make sure they are securely connected.
    - Visually inspect the connector to make sure the two retainer tabs are securely connected.

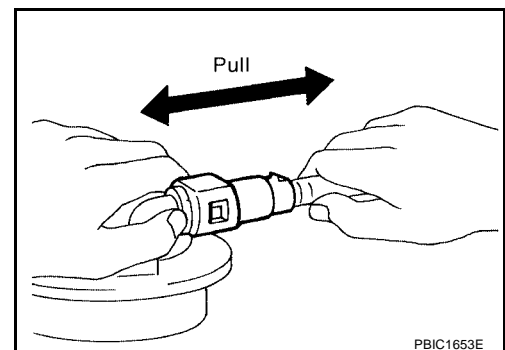

## INSPECTION AFTER INSTALLATION

1. Turn the ignition switch ON but do not start engine, then check the fuel pipes and hose connections for leaks while applying fuel pressure to the system.

## FUEL LEVEL SENSOR UNIT, FUEL FILTER AND FUEL PUMP ASSEMBLY

---

2. Start the engine and rev it above idle speed, then check that there are no fuel leaks at any of the fuel pipe and hose connections.

# FUEL TANK

PFP:17202

EBS00NGB

## FUEL TANK

### Removal and Installation

SEC. 172 • 500

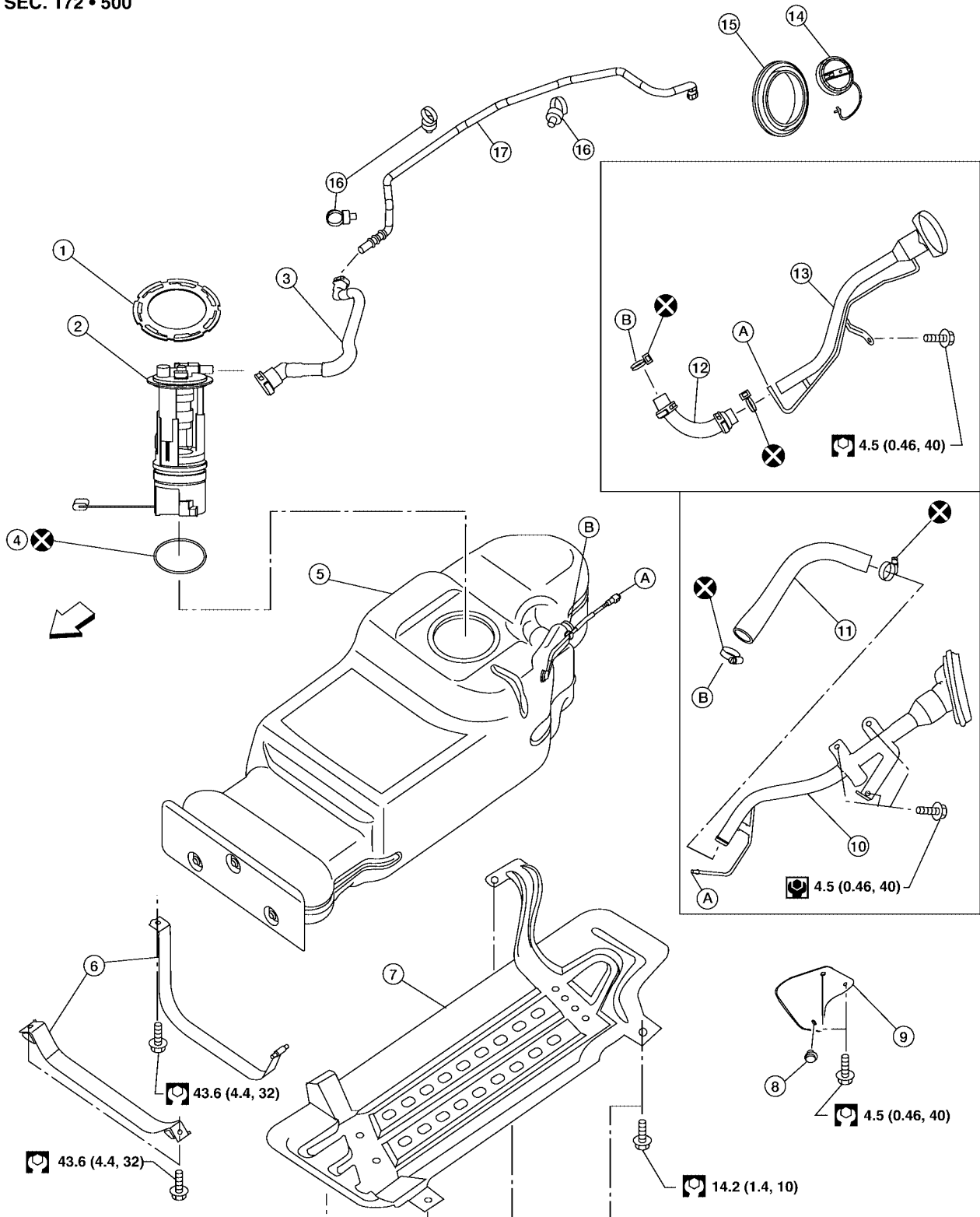

- |  |   |                            |
|--|---|----------------------------|
| 1. Lock ring   | 2. Fuel level sensor, fuel filter, and fuel pump assembly | 3. EVAP hose               |
| 4. Fuel level sensor, fuel filter, and fuel pump assembly O-ring | 5. Fuel tank  | 6. Fuel tank straps        |
| 7. Fuel tank shield  | 8. Clip   | 9. Fuel filler pipe shield |

WBIA0732E

# FUEL TANK

- |                                     |                        |                                |
|-------------------------------------|------------------------|--------------------------------|
| 10. Fuel filler pipe                | 11. Fuel filler hose   | 12. Fuel filler hose           |
| 13. Fuel filler pipe                | 14. Fuel filler cap    | 15. Fuel filler pipe grommet   |
| 16. Clamp                           | 17. EVAP canister hose | A. Fuel filler hose connection |
| B. Fuel filler hose vent connection | ⇐ Front                |                                |

## REMOVAL

### **WARNING:**

Follow the “General Precautions” before working on the fuel system. Refer to [FL-4, "General Precautions"](#) .

1. Remove the fuel filler cap to release the pressure from inside the fuel tank.
2. Remove the LH rear wheel and tire. Refer to [WT-7, "Rotation"](#) .
3. Check the fuel level on level gauge. If the fuel gauge indicates more than the level as shown (full or almost full), drain the fuel from the fuel tank until the fuel gauge indicates the level as shown, or less.

### **NOTE:**

Fuel will be spilled when removing the fuel level sensor, fuel filter, and fuel pump assembly for the fuel level is above the fuel level sensor, fuel filter, and fuel pump assembly fuel tank opening.

- As a guide, the fuel level reaches the fuel gauge position as shown, or less, when approximately 15 ℓ (4 US gal, 3 1/4 Imp gal) of fuel are drained from the fuel tank.
  - If the fuel pump does not operate, use the following procedure to drain the fuel to the specified level.
- a. Insert a suitable hose of less than 15 mm (0.59 in) diameter into the fuel filler pipe through the fuel filler opening to drain the fuel from fuel filler pipe.
  - b. Remove the fuel filler pipe shield.
  - c. Disconnect the fuel filler hose from the fuel filler pipe.
  - d. Insert a suitable hose into the fuel tank through the fuel filler hose to drain the fuel from the fuel tank.
4. Release the fuel pressure from the fuel lines. Refer to [EC-86, "FUEL PRESSURE RELEASE"](#) (QR), [EC-689, "FUEL PRESSURE RELEASE"](#) (VQ).
  5. Disconnect the battery negative terminal.
  6. Remove the fuel tank shield.
  7. Remove the fuel tank strap bolts while supporting the fuel tank with a suitable lift jack.
  8. Lower the fuel tank using a suitable lift jack to access the top of the fuel level sensor, fuel filter, and fuel pump assembly.

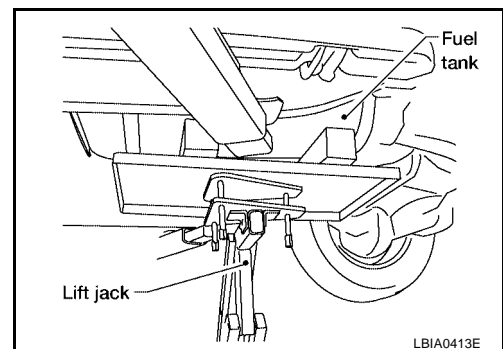
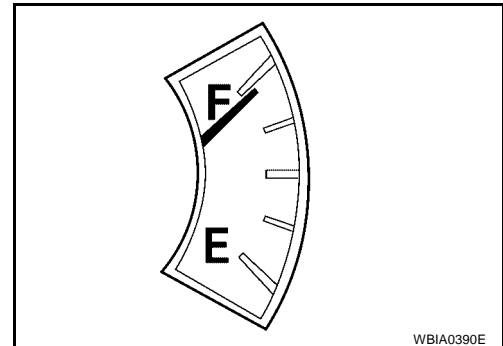

# FUEL TANK

9. Disconnect the fuel level sensor, fuel filter, and fuel pump assembly electrical connector, EVAP hose, and the fuel feed hose.

- Disconnect the fuel feed hose from the molded clip in the side of the fuel tank.

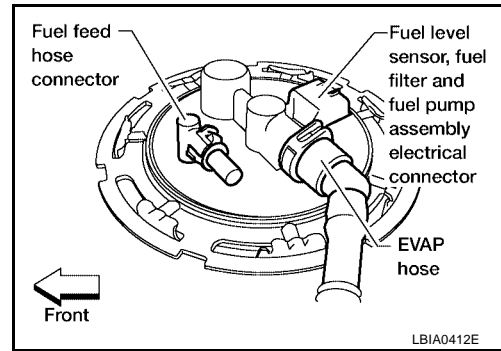

Disconnect the quick connector as follows:

- Hold the sides of the connector, push in tabs and pull out the tube.
- If the connector and the tube are stuck together, push and pull several times until they start to move. Then disconnect them by pulling.

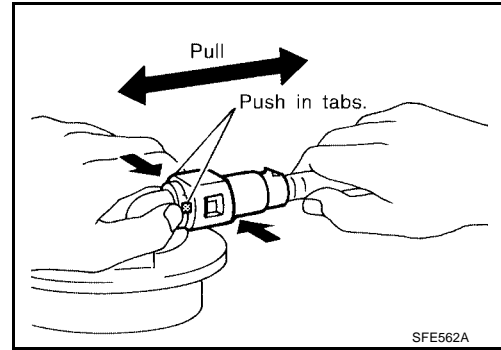

**CAUTION:**

- The quick connector can be disconnected when the tabs are completely depressed. Do not twist the quick connector more than necessary.
- Do not use any tools to disconnect the quick connector.
- Keep the resin tube away from heat. Be especially careful when welding near the tube.
- Prevent any acid liquids such as battery electrolyte, from getting on the resin tube.
- Do not bend or twist the resin tube during connection.
- Do not remove the remaining retainer on the hard tube (or the equivalent) except when the resin tube or the retainer is replaced.
- When the resin tube or hard tube, or the equivalent, is replaced, also replace the retainer with a new one (semi-transparent retainer).

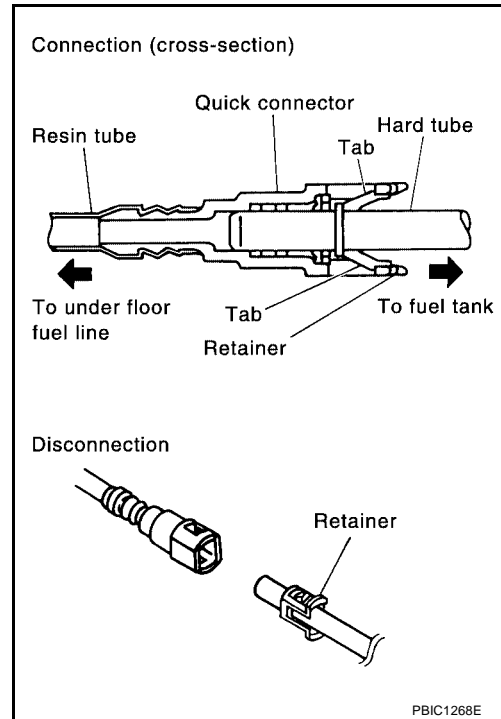

A  
FL  
C  
D  
E  
F  
G  
H  
I  
J  
K  
L  
M

# FUEL TANK

- To keep the quick connector clean and to avoid damage and contamination from foreign materials, cover the quick connector with plastic bags or suitable material as shown.

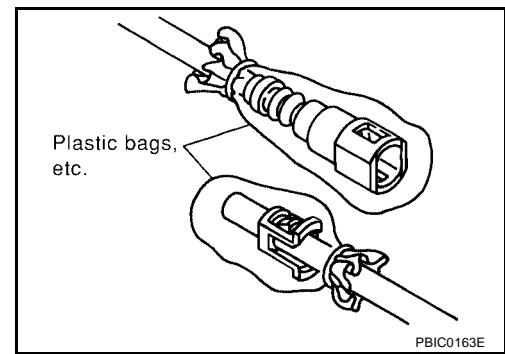

10. Lower the fuel tank using a suitable lift jack and remove it from the vehicle.

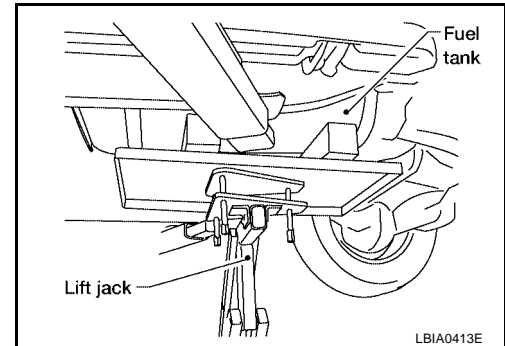

11. Remove the lock ring using Tool as shown.

**Tool number** : — (J-45722)

12. Disconnect the EVAP hose from the molded clip in the top of the fuel tank.
13. Remove the fuel level sensor, fuel filter, and fuel pump assembly. Remove and discard the fuel level sensor, fuel filter, and fuel pump assembly O-ring.

### CAUTION:

- Do not bend the float arm during removal.
- Avoid impacts such as dropping when handling the components.

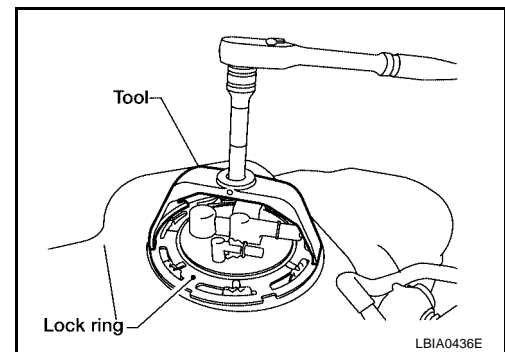

## INSTALLATION

Installation is in the reverse order of removal.

- For installation, use a new fuel level sensor, fuel filter, and fuel pump assembly O-ring.
- Connect the quick connector as follows:
  - Check the connection for any damage or foreign materials.
  - Align the connector with the pipe, then insert the connector straight into the pipe until a click is heard.
  - After connecting the quick connector, make sure that the connection is secure by checking as follows:
    - Pull the tube and the connector to make sure they are securely connected.
    - Visually inspect the connector to make sure the two retainer tabs are securely connected.

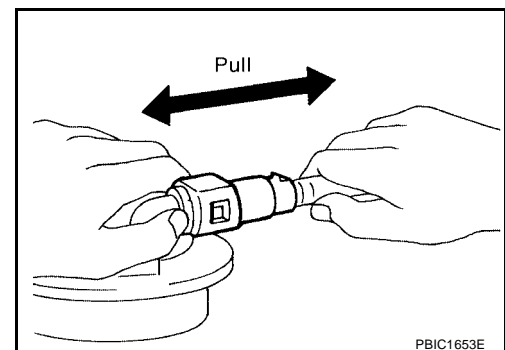

## INSPECTION AFTER INSTALLATION

1. Turn the ignition switch ON but do not start engine, then check the fuel pipes and hose connections for leaks while applying fuel pressure to the system.

# FUEL TANK

- 
2. Start the engine and rev it above idle speed, then check that there are no fuel leaks at any of the fuel pipe and hose connections.

A

**FL**

C

D

E

F

G

H

I

J

K

L

M

# SERVICE DATA AND SPECIFICATIONS (SDS)

---

## SERVICE DATA AND SPECIFICATIONS (SDS)

PFP:00030

### Standard and Limit

EBS00M8T

---

Fuel tank capacity	80 ℓ (21 1/8 US gal, 17 5/8 Imp gal)
--------------------	--------------------------------------

---