

A
B
CL
D
E
F
G
H
I
J
K
L
M

SECTION CL
CLUTCH

CONTENTS

PRECAUTIONS	2	INSTALLATION	11
Precautions for Clutch System	2	Disassembly and Assembly	11
PREPARATION	3	DISASSEMBLY	11
Special Service Tools	3	INSPECTION AFTER DISASSEMBLY	11
Commercial Service Tools	3	ASSEMBLY	11
NOISE, VIBRATION AND HARSHNESS (NVH)		CLUTCH PIPING	13
TROUBLESHOOTING	5	Removal and Installation	13
NVH Troubleshooting Chart	5	CLUTCH RELEASE MECHANISM	14
CLUTCH	5	Removal and Installation (5M/T models)	14
CLUTCH PEDAL	6	REMOVAL	14
On-Vehicle Inspection and Adjustment	6	INSPECTION AFTER REMOVAL	14
Removal and Installation	7	INSTALLATION	15
REMOVAL	7	Removal and Installation (6M/T models)	16
INSPECTION AFTER REMOVAL	7	REMOVAL	16
INSTALLATION	7	INSPECTION AFTER REMOVAL	16
CLUTCH FLUID	8	INSTALLATION	17
Bleeding	8	CLUTCH DISC, CLUTCH COVER	18
CLUTCH MASTER CYLINDER	9	Removal and Installation	18
Removal and Installation	9	REMOVAL	18
REMOVAL	9	INSPECTION AND ADJUSTMENT AFTER	
INSTALLATION	9	REMOVAL	18
Disassembly and Assembly	10	INSTALLATION	20
DISASSEMBLY	10	SERVICE DATA AND SPECIFICATIONS (SDS)	21
INSPECTION AFTER DISASSEMBLY	10	Clutch Control System	21
ASSEMBLY	10	Clutch Master Cylinder	21
OPERATING CYLINDER	11	Clutch Operating Cylinder	21
Removal and Installation	11	Clutch Disc	21
REMOVAL	11	Clutch Cover	21
		Clutch Pedal	21

PRECAUTIONS

PRECAUTIONS

PFP:00001

Precautions for Clutch System

ECS00B7A

- Recommended fluid is Genuine NISSAN Super Heavy Duty Brake Fluid or equivalent. Refer to [MA-11](#), "[Fluids and Lubricants](#)".
- Do not reuse drained brake fluid.
- Be careful not to splash brake fluid on painted areas.
- Use flare nut wrench when removing and installing clutch piping.
- To clean or wash all parts of master cylinder and operating cylinder, use clean brake fluid.
- Do not use mineral oils such as gasoline or kerosene. They will ruin rubber parts of the hydraulic system.

WARNING:

After cleaning clutch disc, wipe it with a dust collector. Do not use compressed air.

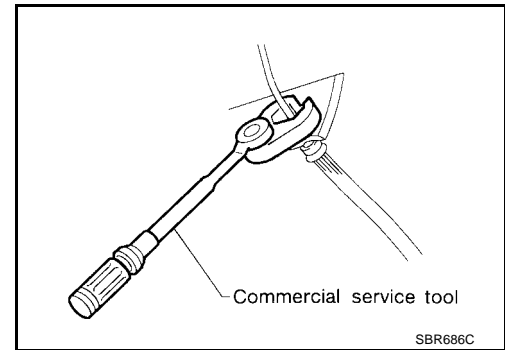

PREPARATION

PREPARATION

PF0:00002

Special Service Tools

ECS00BTB

The actual shapes of Kent-Moore tools may differ from those of special service tools illustrated here.

Tool number (Kent-Moore No.) Tool name	Description
ST20050240 (—) Diaphragm adjusting wrench	Adjusting unevenness of diaphragm spring of clutch cover
ST20630000 (J-26366) Clutch aligning bar	Installing clutch disc a: 15.8 mm (0.622 in) dia. b: 22.9 mm (0.902 in) dia.

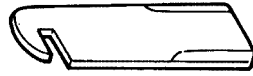

ZZA0508D

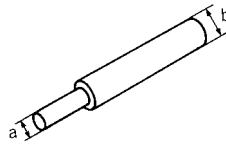

ZZA1178D

Commercial Service Tools

ECS00BTC

Tool name	Description
Pin punch	Removing and installing master cylinder spring pin Tip diameter: 4.5 mm (0.177 in) dia.
Power tool	Loosening bolts and nuts
1. Flare nut crowfoot 2. Torque wrench	Removing and installing clutch piping a: 10 mm (0.39 in)



ZZA0515D

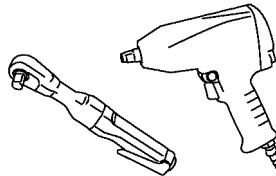

PBIC0190E

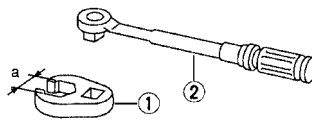

S-NT360

PREPARATION

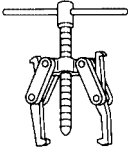
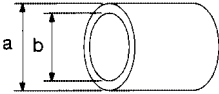
Tool name	Description
Bearing puller  NT077	Removing release bearing
Bearing drift  NT474	Installing release bearing a: 52 mm (2.05 in) dia. b: 45 mm (1.77 in) dia.

NOISE, VIBRATION AND HARSHNESS (NVH) TROUBLESHOOTING

NOISE, VIBRATION AND HARSHNESS (NVH) TROUBLESHOOTING

PF0:0003

NVH Troubleshooting Chart

ECS008TD

Use the chart below to help you find the cause of the symptom. The numbers indicate the order of the inspection. If necessary, repair or replace these parts.

CLUTCH

		Reference page																		
		CL-6	CL-8	CL-10	CL-11	EM-71 (QR25DE), EM-214 (VQ40DE) in ENGINE ASSEMBLY	CL-14	CL-18	CL-18	CL-18	CL-18	CL-18	CL-18	CL-18						
SYMPTOM		SUSPECTED PARTS (Possible cause)																		
Symptom	Clutch grabs/chatters					1			2			2	2			2				
	Clutch pedal spongy		1	2	2															
	Clutch noisy						1													
	Clutch slips	1										2	2			3		4 5		
	Clutch does not disengage	1	2	3	4				5	5	5	5	5		5	6	6	7		
		CLUTCH PEDAL (Free play out of adjustment)	CLUTCH LINE (Air in line)	MASTER CYLINDER PISTON CUP (Damaged)	OPERATING CYLINDER PISTON CUP (Damaged)	ENGINE MOUNTING (Loose)	RELEASE BEARING (Worn, dirty or damaged)	CLUTCH DISC (Out of true)	CLUTCH DISC (Runout is excessive)	CLUTCH DISC (Lining broken)	CLUTCH DISC (Dirty or burned)	CLUTCH DISC (Oily)	CLUTCH DISC (Worn out)	CLUTCH DISC (Hardened)	CLUTCH DISC (Lack of spline grease)	DIAPHRAGM SPRING (Damaged)	DIAPHRAGM SPRING (Out of tip alignment)	PRESSURE PLATE (Distortion)	FLYWHEEL (Distortion)	EM-101 (QR25DE), EM-101 (VQ40DE) in CYLINDER BLOCK

CL
D
E
F
G
H
I
J
K
L
M

CLUTCH PEDAL

CLUTCH PEDAL

PF:46540

On-Vehicle Inspection and Adjustment

ECS00BTE

1. Check to see if the clevis pin floats freely in the bore of the clutch pedal. It should not be bound by the clevis or clutch pedal.
 - a. If the clevis pin is not free, check that the pedal stopper bolt or ASCD clutch switch is not applying pressure to the clutch pedal causing the clevis pin to bind. To adjust, loosen the lock nut and turn the pedal stopper bolt or ASCD clutch switch.
 - b. Tighten the lock nut to the specified torque. Refer to [CL-7, "Removal and Installation"](#).
 - c. Verify that the clevis pin floats in the bore of the clutch pedal. It should not be bound by the clutch pedal.
 - d. If the clevis pin is still not free, remove the clevis pin and check for deformation or damage. Replace clevis pin if necessary. Leave pin removed for step 2.
2. Check clutch pedal stroke for free range of movement.
 - a. With the clevis pin removed, manually move the clutch pedal up and down to determine if it moves freely.
 - b. If any sticking is noted, replace the assembly.
3. Adjust clearance "C" while depressing clutch pedal fully. (With clutch interlock switch)

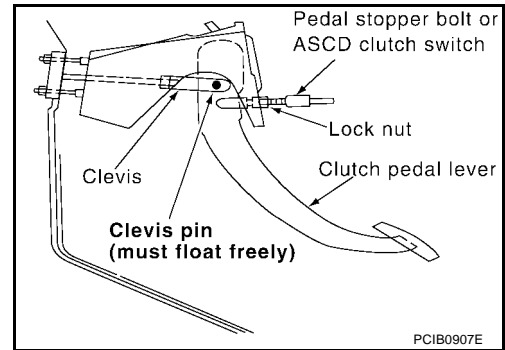

Clearance C : 0.1 - 1.0 mm (0.004 - 0.039 in)

4. Check clutch hydraulic and system components (clutch master cylinder, clutch operating cylinder, clutch withdrawal lever and clutch release bearing) for sticking or binding.
 - a. If any sticking or binding noted, repair or replace related parts as necessary.
 - b. If hydraulic system repair was necessary, bleed the clutch hydraulic system. Refer to [CL-8, "Bleeding"](#).

NOTE:

Do not use a vacuum assist or any other type of power bleeder on this system. Use of a vacuum assist or power bleeder will not purge all the air from the system.

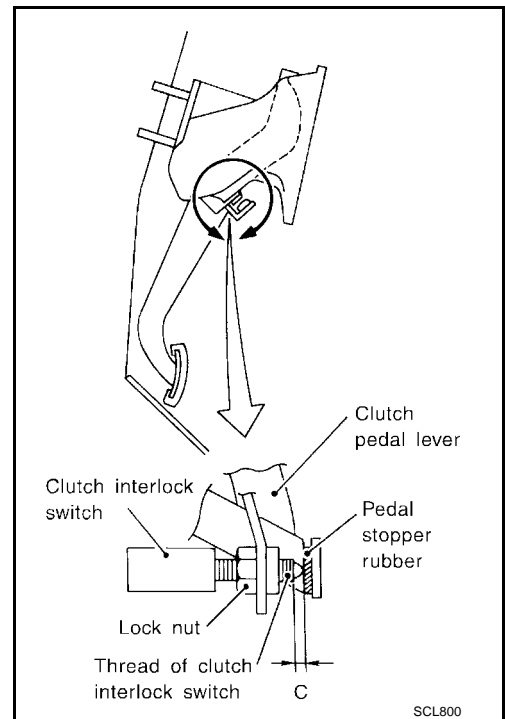

CLUTCH PEDAL

Removal and Installation

ECS00BTF

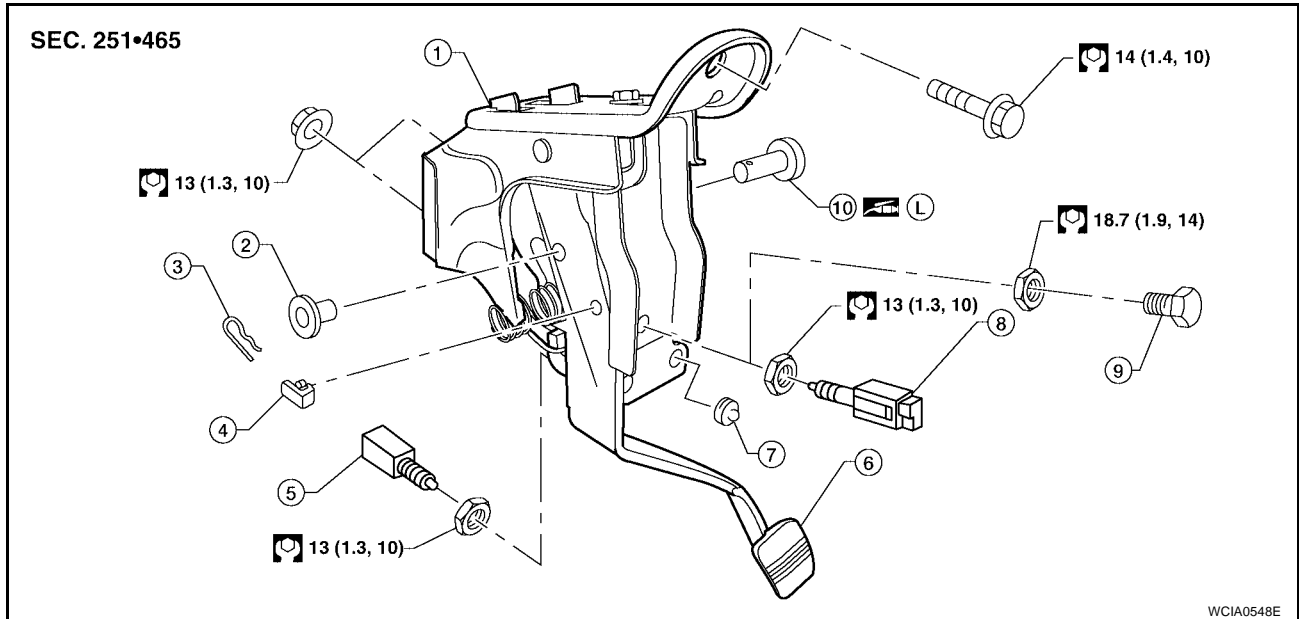

- | | | |
|-------------------------|-----------------------------------|--------------------------------------|
| 1. Bracket | 2. Bushing | 3. Snap pin |
| 4. Pedal stopper rubber | 5. Clutch interlock switch | 6. Clutch pedal |
| 7. Stopper rubber | 8. ASCD clutch switch (with ASCD) | 9. Pedal stopper bolt (without ASCD) |
| 10. Clevis pin | | |

REMOVAL

1. Remove the clutch pedal bracket nuts from inside the engine compartment.
2. Disconnect the clutch interlock switch and ASCD clutch switch, then remove the wiring harness from the pedal assembly.
3. Remove the snap pin and clevis pin.
4. Remove the pedal bracket bolt and then remove the clutch pedal assembly.

INSPECTION AFTER REMOVAL

- Inspect the clutch pedal for bends, damage, or cracked welds. Replace if necessary.
- Make sure that the assist spring and return spring have not lost their spring. Replace if necessary.

INSTALLATION

Installation is in the reverse order of removal.

- After installation, inspect and adjust the clutch pedal as necessary. Refer to [CL-6, "On-Vehicle Inspection and Adjustment"](#).

NOTE:

Tighten the pedal stopper bolt lock nut or ASCD clutch switch lock nut to the specified torque after installing the clutch pedal assembly in the vehicle and adjusting the pedal free play.

CLUTCH FLUID

CLUTCH FLUID

PFP:00017

Bleeding

ECS00BTG

CAUTION:

Do not spill clutch fluid onto painted surfaces. If it spills, wipe up immediately and wash the affected area with water.

NOTE:

- Do not use a vacuum assist or any other type of power bleeder on this system. Use of a vacuum assist or power bleeder will not purge all the air from the system.
 - Monitor the fluid level in the reservoir tank to make sure it does not empty.
1. Top off reservoir with new recommended brake fluid. Refer to [MA-11, "RECOMMENDED FLUIDS AND LUBRICANTS"](#) .
 2. Connect a transparent vinyl tube and container to the air bleeder valve on the clutch operating cylinder.
 3. Fully depress the clutch pedal several times.
 4. With the clutch pedal depressed, open the bleeder valve to release the air.
 5. Close the bleeder valve.
 6. Repeat steps 3 to 5 until clear brake fluid comes out of the air bleeder valve.
 7. Tighten the air bleeder to the specified torque. Refer to [CL-11, "Removal and Installation"](#) .

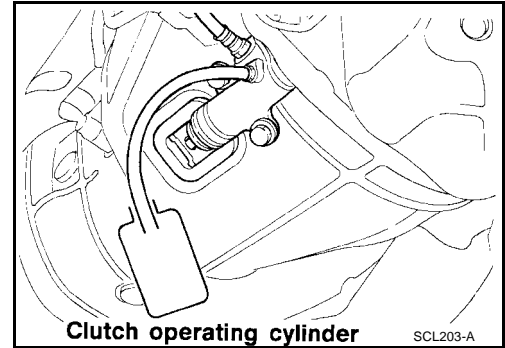

CLUTCH MASTER CYLINDER

PFP:30610

ECS00BTH

CLUTCH MASTER CYLINDER

Removal and Installation

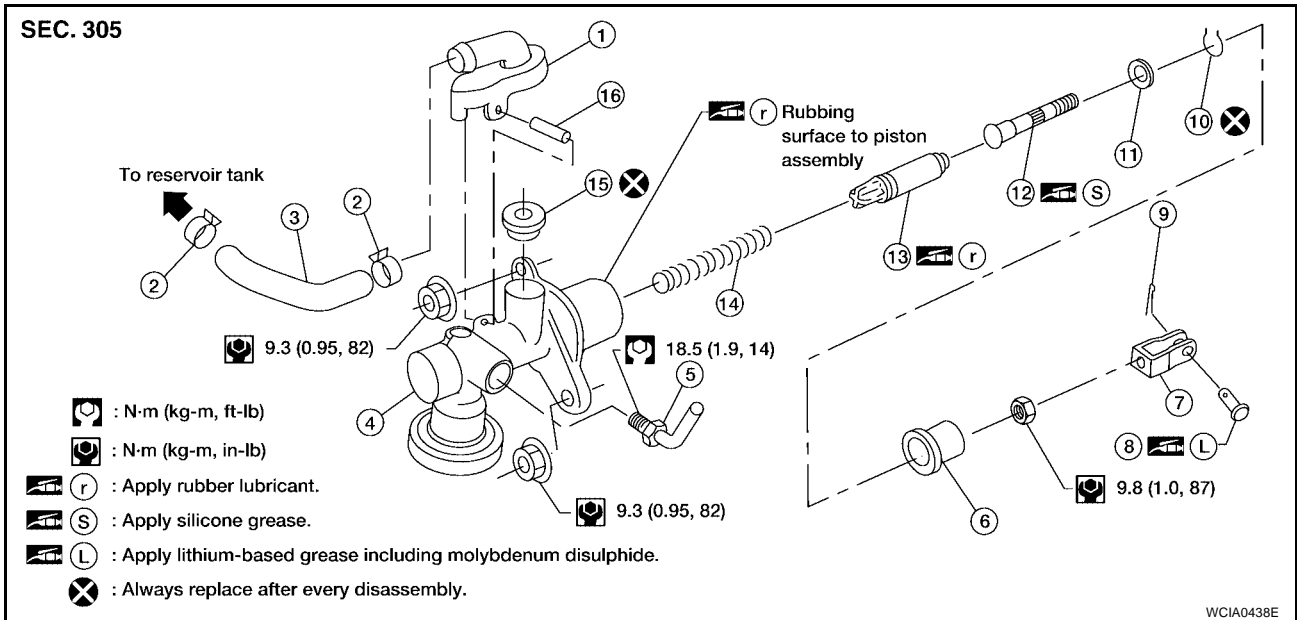

- | | | |
|---------------------|-------------------|--------------------|
| 1. Nipple | 2. Clamp | 3. Reservoir hose |
| 4. Cylinder body | 5. Clutch tube | 6. Dust cover |
| 7. Clevis | 8. Clevis pin | 9. Snap pin |
| 10. Stopper ring | 11. Stopper | 12. Push rod |
| 13. Piston assembly | 14. Return spring | 15. Reservoir seal |
| 16. Spring pin | | |

REMOVAL

- Remove the snap pin and clevis pin from the clevis, and separate it from the clutch pedal.
- Drain the brake fluid from the clutch hydraulic system.

CAUTION:

Do not spill brake fluid onto painted surfaces. If it spills, wipe up immediately and wash the affected area with water.

- Remove the hose clamp and hose from the clutch master cylinder.
- Remove the clutch tube using suitable tool.
- Remove the clutch master cylinder nuts, and remove the clutch master cylinder from the vehicle.

INSTALLATION

Installation is in the reverse order of removal.

- Before installation, check the position of the clevis and push rod. If "L" is outside standard length, adjust the position of the clevis and push rod.

Length "L"

(for QR25DE engine models) : 119.5 mm (4.70 in)

(for VQ40DE engine models) : 120.5 mm (4.74 in)

- After installation, inspect and adjust the clutch pedal as necessary, then bleed the clutch hydraulic system. Refer to [CL-6, "On-Vehicle Inspection and Adjustment"](#) and [CL-8, "Bleeding"](#).

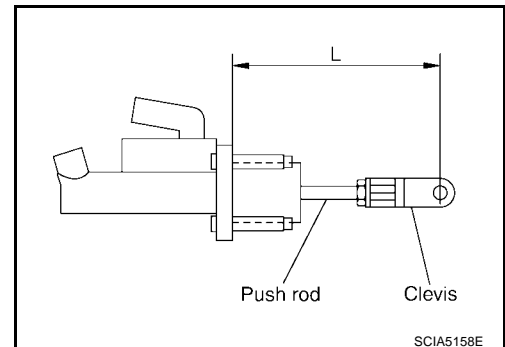

CLUTCH MASTER CYLINDER

ECS00BT1

Disassembly and Assembly

DISASSEMBLY

1. Remove the spring pin, using suitable tool.
2. Remove the nipple and reservoir seal from the cylinder body.
3. Loosen the push rod lock nut then remove the clevis and lock nut, if necessary.

NOTE:

Clutch pedal height is controlled with the position of the clevis and push rod.

4. Remove the dust cover from the cylinder body.
5. Remove the stopper ring and stopper. Remove the push rod from the cylinder body while holding it securely to prevent the piston assembly from popping out.
6. Remove the piston assembly and return spring.

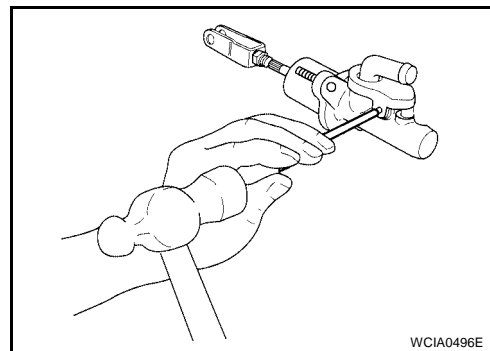

WCIA0496E

INSPECTION AFTER DISASSEMBLY

Inspect for the following, replace parts as necessary.

- Damage, foreign material, wear, corrosion, and pin holes on the cylinder inner surface
- Damaged or deformed nipple
- Weak spring
- Cracked or deformed dust cover

ASSEMBLY

1. Apply rubber lubricant to the internal surface of the cylinder body, sliding surface of piston assembly, and the piston cup. Insert the return spring and piston assembly to the cylinder body.
2. Apply silicone grease to the push rod and install the stopper and stopper ring.

CAUTION:

Restrain the push rod while doing this because there is a danger the piston assembly will fly out of the master cylinder.

3. Install the dust cover to the cylinder body.
4. Install the reservoir seal and nipple to the cylinder body.
5. Install the clevis to the push rod.
6. Check and adjust the position of the clevis and push rod. After adjusting "L", tighten lock nut to the specified torque. Refer to [CL-9, "Removal and Installation"](#).

Length "L"

(for QR25DE engine models) : 119.5 mm (4.70 in)

(for VQ40DE engine models) : 120.5 mm (4.74 in)

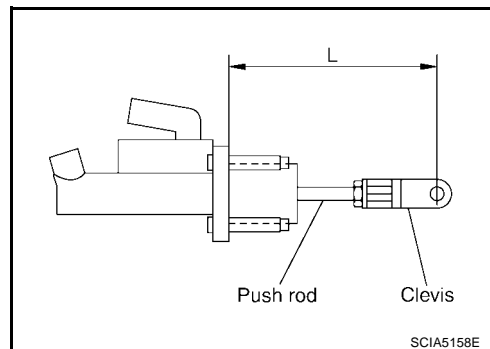

SCIA5158E

OPERATING CYLINDER

PF3:30620

OPERATING CYLINDER Removal and Installation

ECS00BTJ

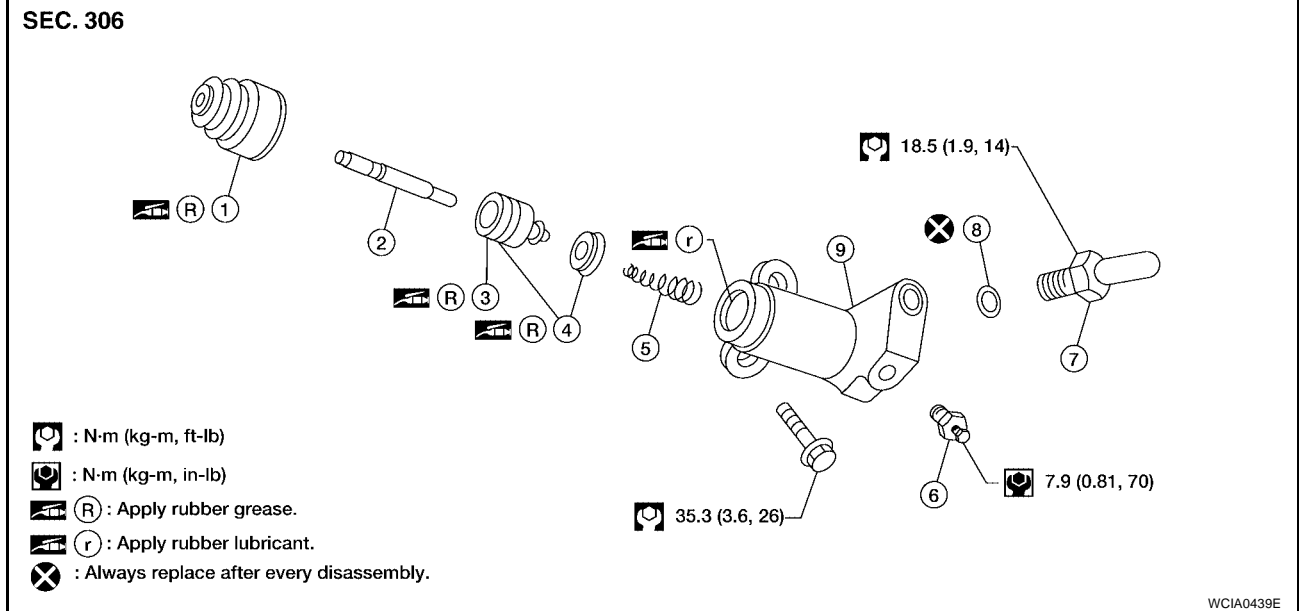

- | | | |
|----------------|------------------|------------------|
| 1. Dust cover | 2. Push rod | 3. Piston |
| 4. Piston cup | 5. Piston spring | 6. Air bleeder |
| 7. Clutch hose | 8. Copper washer | 9. Cylinder body |

REMOVAL

1. Drain the brake fluid from the clutch hydraulic system.

CAUTION:

Do not spill brake fluid on painted surfaces. If it spills, wipe up immediately and wash the affected area with water.

2. Remove the clutch hose and copper washer from the operating cylinder.

CAUTION:

Do not reuse the copper washer.

3. Remove the operating cylinder bolts, and remove the operating cylinder from the vehicle.

INSTALLATION

Installation is in the reverse order of removal.

- Tighten the clutch hose fitting to the specified torque. Refer to [CL-11, "Removal and Installation"](#).

CAUTION:

Make sure the clutch hose is not bent or twisted.

- After installation, bleed the clutch hydraulic system. Refer to [CL-8, "Bleeding"](#).

Disassembly and Assembly DISASSEMBLY

ECS00BTK

- Remove the dust cover, push rod and piston assembly from the cylinder body.

INSPECTION AFTER DISASSEMBLY

Inspect for the following, replace parts as necessary.

- Damage, foreign material, wear, corrosion, and pinholes on the cylinder inner surface, piston, and sliding part of piston cup
- Weak spring
- Cracked or deformed dust cover

ASSEMBLY

1. Apply rubber lubricant to the cylinder body inner surface and rubber grease to the piston cup and piston.
2. Insert the piston assembly and piston spring into the cylinder body.

OPERATING CYLINDER

3. Apply rubber grease to the dust cover and install the push rod and dust cover.

CLUTCH PIPING

PFP:30650

CLUTCH PIPING

Removal and Installation

ECS00BTL

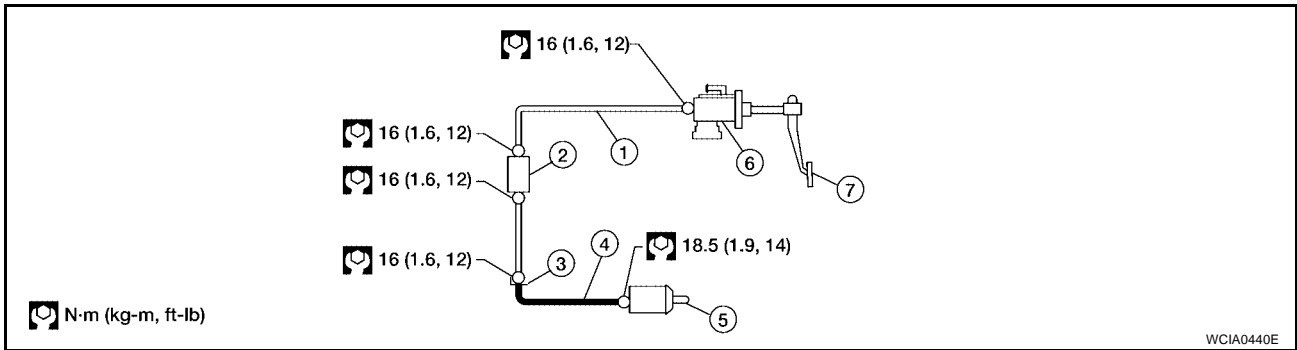

- | | | |
|-----------------|-----------------------|--------------------|
| 1. Clutch tube | 2. Clutch orifice | 3. Lock plate |
| 4. Clutch hose | 5. Operating Cylinder | 6. Master cylinder |
| 7. Clutch pedal | | |

Carefully observe the following during clutch tube removal and installation.

CAUTION:

Do not spill brake fluid onto painted surfaces. If it spills, wipe up immediately and wash the affected area with water.

- When installing the clutch hose to the bracket, align the clutch hose metal fittings with the bracket positioning emboss, then install the lock plate to secure.

CAUTION:

- Do not damage the clutch hose.
- Make sure the clutch hose is not bent or twisted.
- Tighten the clutch tube and hose fittings to the specified torque.

CAUTION:

- Do not reuse the copper washer.
- Do not damage the clutch tube fittings or clutch tube.
- After installation, bleed the air from the clutch hydraulic system. Refer to [CL-8, "Bleeding"](#).

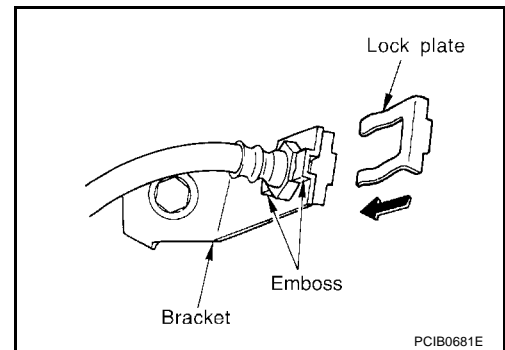

CLUTCH RELEASE MECHANISM

CLUTCH RELEASE MECHANISM

PFP:30502

Removal and Installation (5M/T models)

ECS00BTM

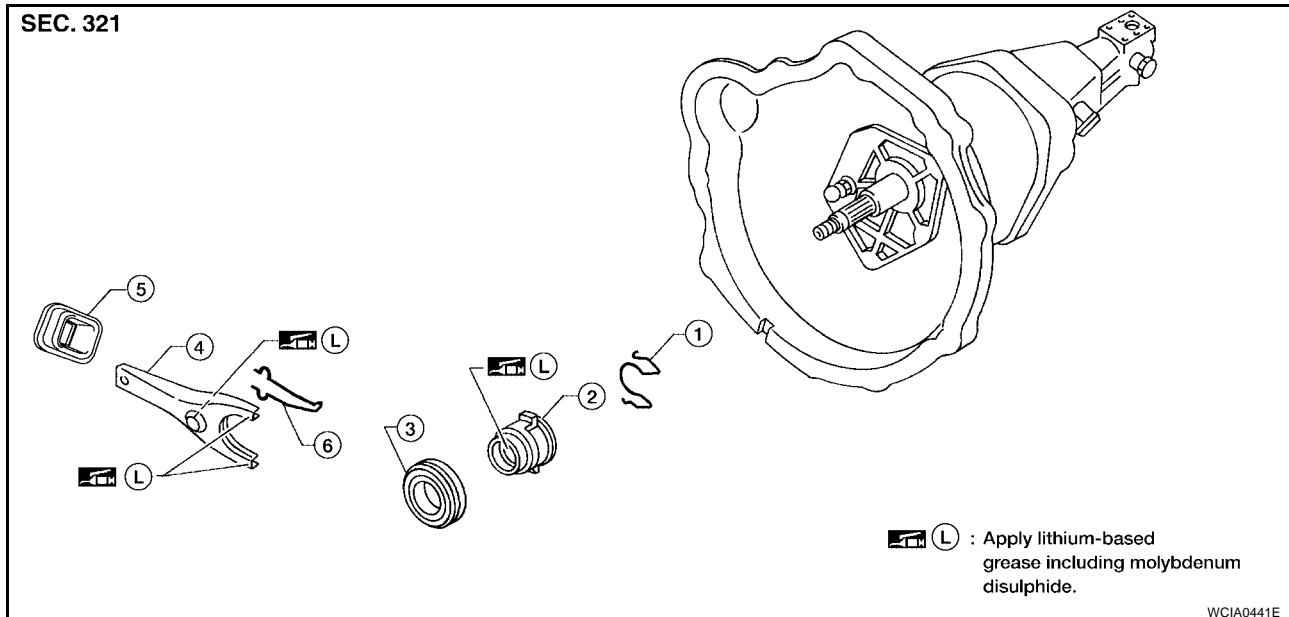

- | | | |
|---------------------|---------------------------|--------------------|
| 1. Holder spring | 2. Release bearing sleeve | 3. Release bearing |
| 4. Withdrawal lever | 5. Dust cover | 6. Retainer spring |

REMOVAL

1. Remove the manual transmission from the vehicle. Refer to [MT-15, "Removal and Installation from Vehicle"](#).
2. Remove the release bearing sleeve assembly, holder spring, and withdrawal lever from inside the clutch housing.
3. Remove the dust cover.
4. Remove the retainer spring from the withdrawal lever.
5. Remove the release bearing from release bearing sleeve using suitable tool.

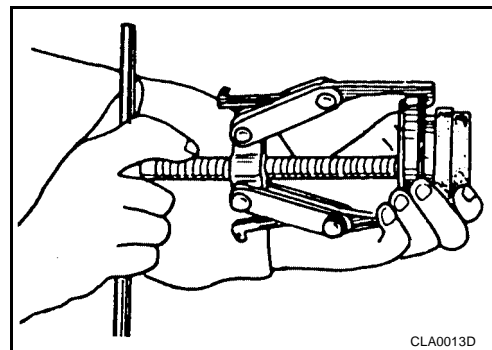

INSPECTION AFTER REMOVAL

- Replace the release bearing if it is seized, damaged, faulty in rotation direction, or has poor aligning function.
- Replace the withdrawal lever if its contact surface is worn abnormally.
- Replace the dust seal if it is deformed or cracked.

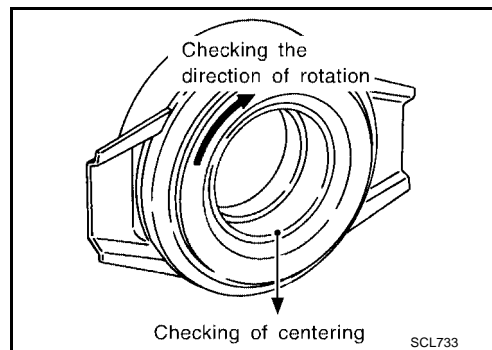

CLUTCH RELEASE MECHANISM

INSTALLATION

Installation is in the reverse order of removal.

NOTE:

- Install the release bearing to release bearing sleeve using suitable tool, as shown.

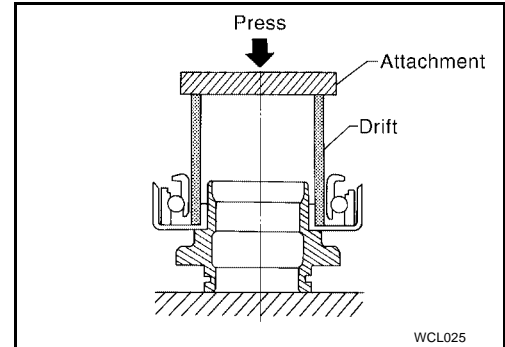

- Clean old grease and abrasive materials off the grease application areas.
- Apply grease to the specified points as shown.

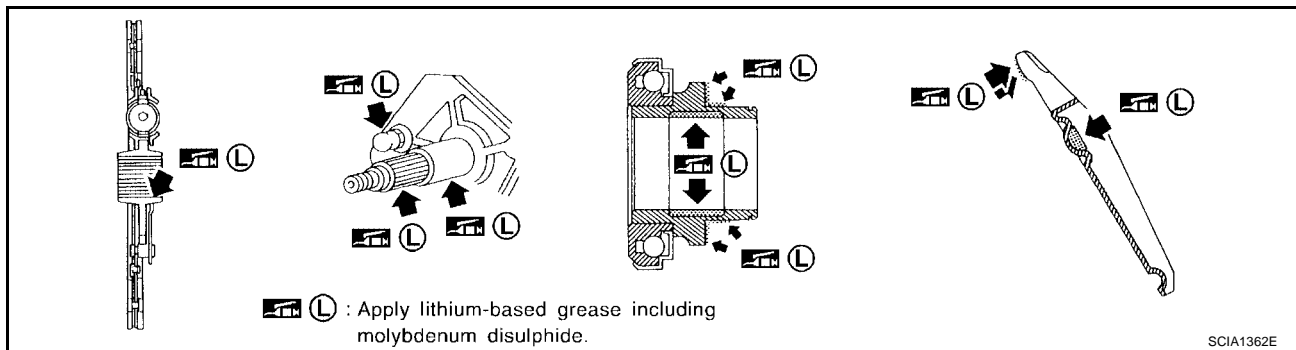

- Apply approximately 1 mm (0.04 in) thick coat of clutch sleeve grease to withdrawal lever and holder spring frictional surfaces.
- Apply a coat of clutch sleeve grease to ball pin contact surface of the withdrawal lever and inner slots of the release bearing. The grease surface should be level with the surrounding area.
- Apply a thin coat of clutch sleeve grease to the release bearing frictional surface. After grease application, install release bearing. Wipe off excess grease forced out during bearing installation.

CAUTION:

- Be careful not to bring any grease into contact with the clutch disc facing, pressure plate surface, or flywheel surface.
- Before installing manual transmission to the vehicle, check that each sliding surface slides smoothly by operating withdrawal lever.

CLUTCH RELEASE MECHANISM

Removal and Installation (6M/T models)

ECS00BTU

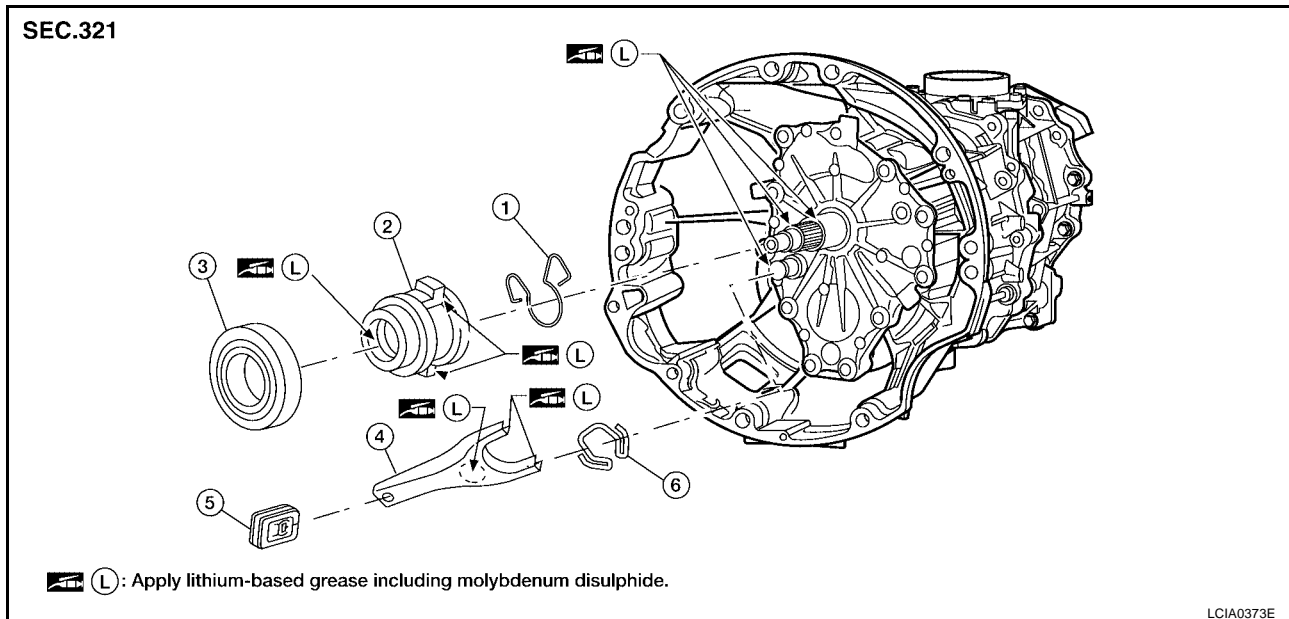

- | | | |
|---------------------|---------------------------|--------------------|
| 1. Holder spring | 2. Release bearing sleeve | 3. Release bearing |
| 4. Withdrawal lever | 5. Dust cover | 6. Snap spring |

REMOVAL

1. Remove the manual transmission from the vehicle. Refer to [MT-66, "Removal and Installation from Vehicle \(For 2WD Models\)"](#) or [MT-68, "Removal and Installation from Vehicle \(For 4WD Models\)"](#).
2. Remove the release bearing sleeve assembly, holder spring, and withdrawal lever from inside the clutch housing.
3. Remove the dust cover.
4. Remove the snap spring from the withdrawal lever.
5. Remove the release bearing from release bearing sleeve using suitable tool.

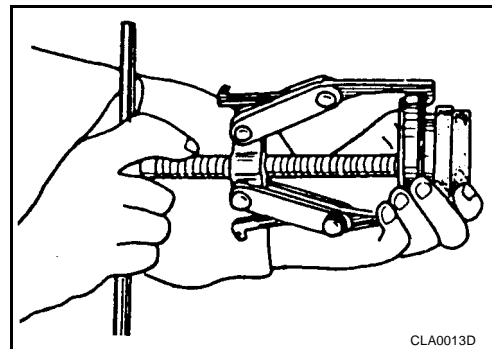

INSPECTION AFTER REMOVAL

- Replace the release bearing if it is seized, damaged, faulty in rotation direction, or has poor aligning function.
- Replace the withdrawal lever if its contact surface is worn abnormally.
- Replace the dust seal if it is deformed or cracked.

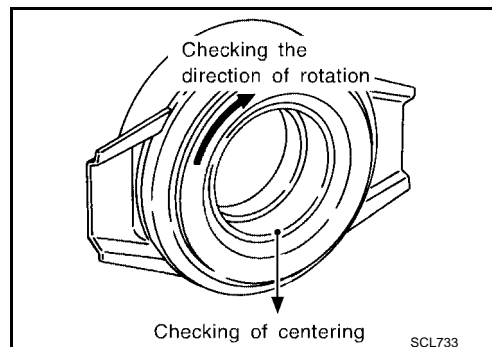

CLUTCH RELEASE MECHANISM

INSTALLATION

Installation is in the reverse order of removal.

NOTE:

- Install the release bearing to release bearing sleeve using suitable tool, as shown.

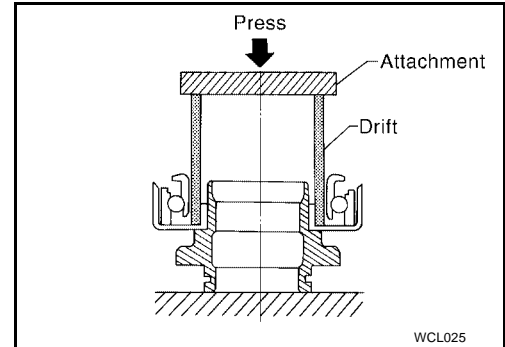

- Clean old grease and abrasive materials off the grease application areas.
- Apply grease to the specified points as shown.

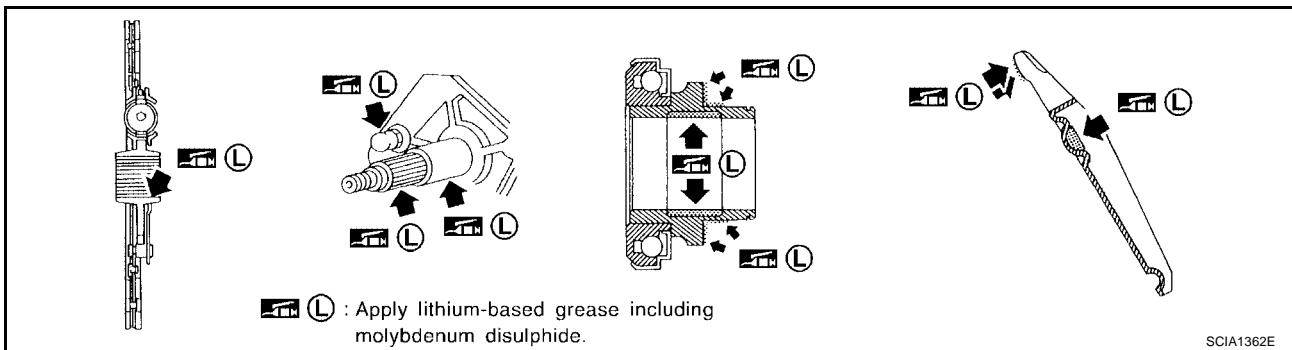

- Apply approximately 1 mm (0.04 in) thick coat of clutch sleeve grease to withdrawal lever and holder spring frictional surfaces.
- Apply a coat of clutch sleeve grease to ball pin contact surface of the withdrawal lever and inner slots of the release bearing. The grease surface should be level with the surrounding area.
- Apply a thin coat of clutch sleeve grease to the release bearing frictional surface. After grease application, install release bearing. Wipe off excess grease forced out during bearing installation.

CAUTION:

- Before installing the manual transaxle to the vehicle, check that each sliding surface slides smoothly by operating withdrawal lever.
- Be careful not to bring any grease into contact with the clutch disc facing, pressure plate surface, or flywheel surface.
- When assembling, make sure that both ends of the snap spring touch the end face of the withdrawal lever.
- Be careful with the orientation of the installation.

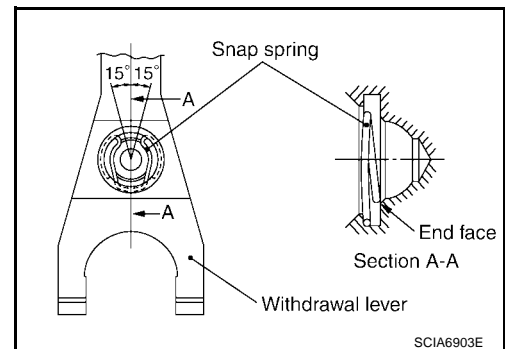

CLUTCH DISC, CLUTCH COVER

CLUTCH DISC, CLUTCH COVER

PF3:30100

Removal and Installation

ECS008TN

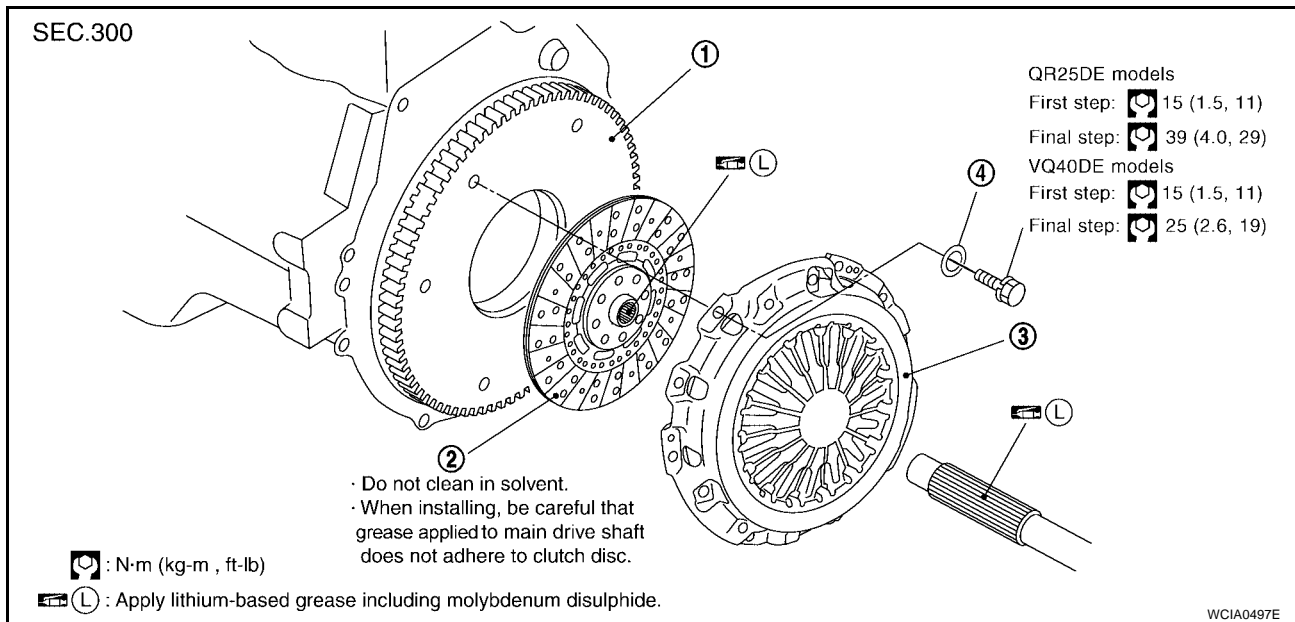

1. Flywheel
2. Clutch disc
3. Clutch cover
4. Washer (for QR25DE models)

CAUTION:

- Do not clean the clutch disc with solvent.
- When installing, do not get grease from the main drive shaft onto the clutch disc friction surface.
- If the flywheel is removed, align the dowel pin with the smallest hole of flywheel. Refer to [EM-222, "ASSEMBLY"](#) in CYLINDER BLOCK (for VQ40DE models).

REMOVAL

1. Remove the manual transmission from the vehicle. Refer to [MT-15, "Removal and Installation from Vehicle"](#) (QR25DE), [MT-66, "Removal and Installation from Vehicle \(For 2WD Models\)"](#) (VQ40DE) or [MT-68, "Removal and Installation from Vehicle \(For 4WD Models\)"](#) (VQ40DE).
2. Remove the clutch cover bolts using power tool. Remove the clutch cover and clutch disc.

INSPECTION AND ADJUSTMENT AFTER REMOVAL

Clutch Disc

- Check the clutch disc for wear of facing.

Wear limit (depth to rivet head) :0.3 mm (0.012 in)

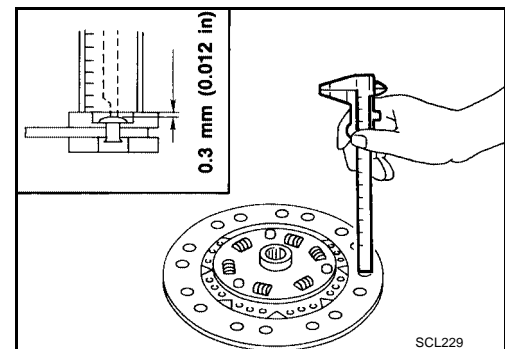

CLUTCH DISC, CLUTCH COVER

- Measure the circumference runout at the point indicated. If it is outside the specification, replace the clutch disc.

Runout limit/diameter of the area to be measured:

(for QR25DE engine models) :0.7 mm (0.028 in) or less/230 mm (9.06 in) dia.

(for VQ40DE engine models) :1.0 mm (0.039 in) or less/250 mm (9.84 in) dia.

- Measure the backlash of the clutch disc spline at the circumference of the disc. If it is outside the specification, replace the clutch disc.

Maximum backlash of spline (at outer disc edge) : 1.0 mm (0.039 in)

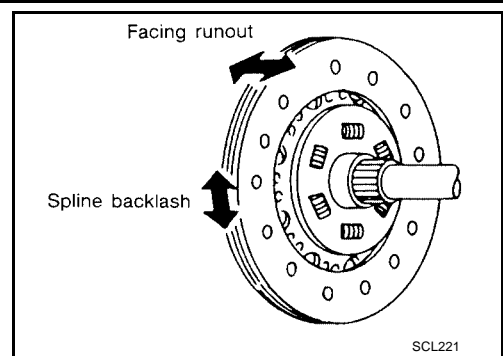

Clutch Cover

With the clutch cover installed on the vehicle, check the diaphragm spring toe height for unevenness. If they exceed the tolerance, adjust the height using Tool.

Uneven limit of diaphragm spring toe height :0.7mm (0.028 in)

Tool number : ST20050240 (—)

- Check clutch cover thrust ring for wear or breakage. If wear or breakage is found, replace clutch cover assembly.

NOTE:

- Worn thrust ring will generate a beating noise when tapped at the rivet with a hammer.
- Broken thrust ring will make a clinking sound when cover is shaken up and down.
- If a trace of burn or discoloration is found on the clutch cover pressure plate to clutch disc contact surface, repair the surface with emery paper. If surface is damaged or distorted, replace the assembly.

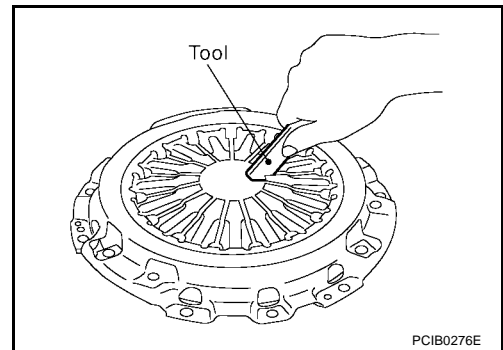

Flywheel

- Check contact surface of flywheel for slight burns or discoloration. If any are found, repair flywheel with emery paper.
- Check the flywheel runout. Refer to [EM-92, "Inspection After Disassembly"](#) (QR25DE) or [EM-233, "Inspection After Disassembly"](#) (VQ40DE).

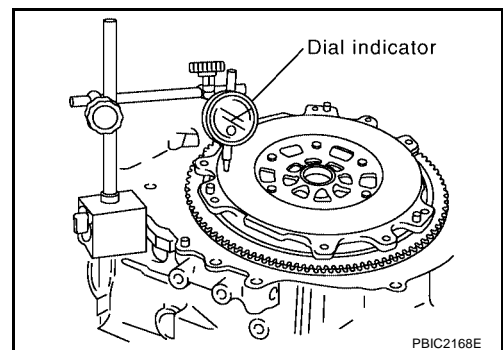

CLUTCH DISC, CLUTCH COVER

INSTALLATION

1. Apply recommended grease to clutch disc and main drive shaft spline.

CAUTION:

Do not allow grease to contaminate the clutch facing.

2. Install clutch disc and clutch cover. Pre-tighten the bolts and install Tool. Then tighten the clutch cover bolts evenly in two steps in the order shown. Refer to [CL-18, "Removal and Installation"](#).

QR25DE models

First step : 15 N·m (1.5 kg-m, 11 ft-lb)

Final step : 39 N·m (4.0 kg-m, 29 ft-lb)

Tool number : ST20630000 (J-26366)

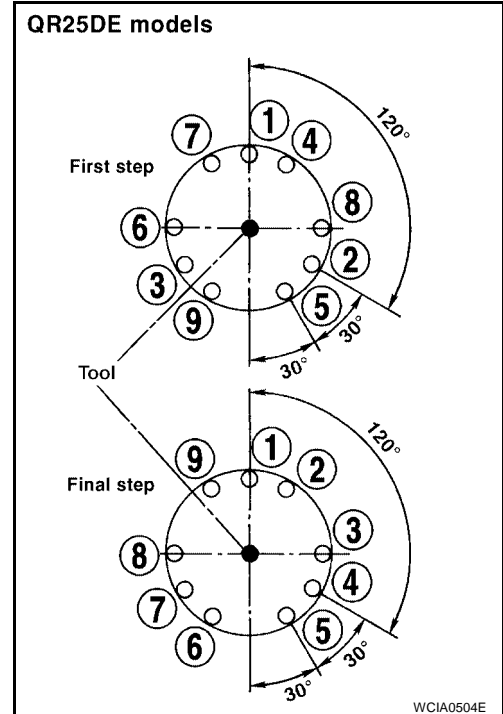

VG40DE model

First step : 15 N·m (1.5 kg-m, 11 ft-lb)

Final step : 25 N·m (2.6 kg-m, 19 ft-lb)

Tool number : ST20630000 (J-26366)

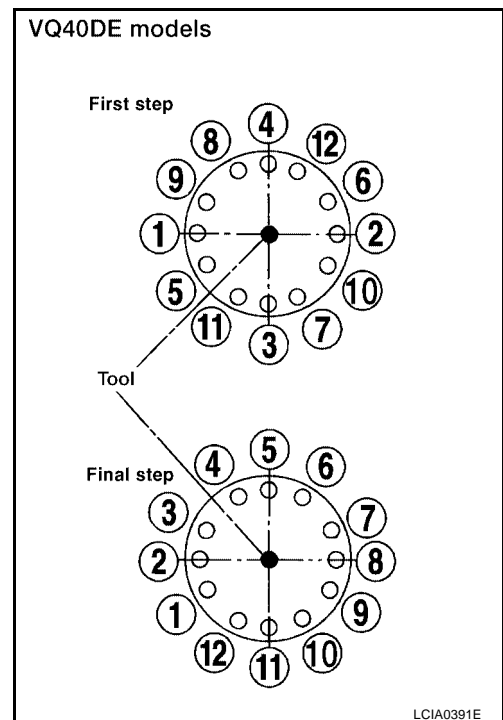

3. Install the manual transmission. Refer to [MT-15, "Removal and Installation from Vehicle"](#) (QR25DE), [MT-66, "Removal and Installation from Vehicle \(For 2WD Models\)"](#) (VQ40DE) or [MT-68, "Removal and Installation from Vehicle \(For 4WD Models\)"](#) (VQ40DE).

SERVICE DATA AND SPECIFICATIONS (SDS)

SERVICE DATA AND SPECIFICATIONS (SDS)

PF0:00030

Clutch Control System

ECS00BTO

Type of clutch control	Hydraulic
------------------------	-----------

Clutch Master Cylinder

ECS00BTP

Unit: mm (in)

Inner diameter	15.87 (5/8)
----------------	-------------

Clutch Operating Cylinder

ECS00BTQ

Unit: mm (in)

Inner diameter	19.05 (3/4)
----------------	-------------

Clutch Disc

ECS00BTR

Unit: mm (in)

Engine model	QR25DE	VQ40DE
Model	240	260
Facing size (Outer dia. × inner dia. × thickness)	240 × 160 × 3.5 (9.45 × 6.30 × 0.138)	260 × 190 × 3.2 (10.24 × 7.48 × 0.126)
Wear limit (depth to rivet head)	0.3 (0.012)	
Runout limit/diameter of the area to be measured	0.7 (0.028) or less/230 (9.06) dia.	1.0 (0.039) or less/250 (9.84) dia.
Maximum backlash of spline (at outer disc edge)	1.0 (0.039)	

Clutch Cover

ECS00BTS

Unit: mm (in)

Engine model	QR25DE	VQ40DE
Set-load	5890 N (600 kg, 1324 lb)	8340 N (850 kg, 1875 lb)
Diaphragm spring lever height	37.0 - 39.0 (1.457 - 1.535)	44.0 - 46.0 (1.732 - 1.811)
Uneven limit of diaphragm spring toe height	0.7 (0.028)	

Clutch Pedal

ECS00BTT

Unit: mm (in)

Clearance "C" between pedal stopper rubber and clutch interlock switch threaded while clutch pedal is fully depressed.	0.1 - 1.0 (0.004 - 0.039)
--	---------------------------

A
B
CL
D
E
F
G
H
I
J
K
L
M

SERVICE DATA AND SPECIFICATIONS (SDS)
