

SECTION **DI**

DRIVER INFORMATION SYSTEM

A
B
C

CONTENTS

<p>PRECAUTIONS 2</p> <p>Precautions for Supplemental Restraint System (SRS) “AIR BAG” and “SEAT BELT PRE-TENSIONER” 2</p> <p>Wiring Diagrams and Trouble Diagnosis 2</p> <p>METERS AND GAUGES 3</p> <p>Component Parts and Harness Connector Location... 3</p> <p>System Description 4</p> <p> UNIFIED CONTROL METER 4</p> <p> HOW TO CHANGE THE DISPLAY FOR ODO/TRIP METER 4</p> <p> POWER SUPPLY AND GROUND CIRCUIT 4</p> <p> FUEL GAUGE 4</p> <p> WATER TEMPERATURE GAUGE 4</p> <p> TACHOMETER 5</p> <p> SPEEDOMETER 5</p> <p>Combination Meter 6</p> <p>Wiring Diagram — METER — 8</p> <p>Meter/Gauge Operation and Odo/Trip Meter Segment Check in Diagnosis Mode 9</p> <p> DIAGNOSIS FUNCTION 9</p> <p> HOW TO ALTERNATE DIAGNOSIS MODE 9</p> <p>Trouble Diagnoses 10</p> <p> PRELIMINARY CHECK 10</p> <p> SYMPTOM CHART 11</p> <p> POWER SUPPLY AND GROUND CIRCUIT CHECK 12</p> <p> INSPECTION/VEHICLE SPEED SENSOR 13</p> <p> INSPECTION/ENGINE REVOLUTION SIGNAL.. 14</p> <p> INSPECTION/FUEL LEVEL SENSOR UNIT 15</p> <p> INSPECTION/THERMAL TRANSMITTER 16</p> <p>Electrical Components Inspection 18</p> <p> FUEL LEVEL SENSOR UNIT CHECK 18</p> <p> THERMAL TRANSMITTER CHECK 18</p> <p> VEHICLE SPEED SENSOR SIGNAL CHECK ... 19</p> <p>COMPASS AND THERMOMETER 20</p> <p>System Description 20</p> <p> OUTSIDE TEMPERATURE DISPLAY 20</p>	<p> DIRECTION DISPLAY 20</p> <p> Wiring Diagram — COMPAS — 21</p> <p> KING CAB 21</p> <p> CREW CAB 22</p> <p> Trouble Diagnoses 23</p> <p> PRELIMINARY CHECK FOR THERMOMETER.. 23</p> <p> INSPECTION/COMPASS AND THERMOMETER 23</p> <p> Calibration Procedure for Compass 24</p> <p> CORRECTION FUNCTIONS OF COMPASS 24</p> <p> INITIAL CORRECTION PROCEDURE FOR COMPASS 24</p> <p>WARNING LAMPS 25</p> <p>Circuit Diagram 25</p> <p>Wiring Diagram — WARN — 26</p> <p> MODELS WITHOUT POWER DOOR LOCKS ... 28</p> <p> MODELS WITH POWER DOOR LOCKS 29</p> <p>Electrical Components Inspection 34</p> <p> FUEL WARNING LAMP SENSOR CHECK 34</p> <p> OIL PRESSURE SWITCH CHECK 34</p> <p> DIODE CHECK 34</p> <p>WARNING CHIME 35</p> <p>Component Parts and Harness Connector Location.. 35</p> <p>System Description 36</p> <p> MODELS WITHOUT POWER DOOR LOCKS ... 36</p> <p> MODELS WITH POWER DOOR LOCKS 36</p> <p>Wiring Diagram — CHIME — 38</p> <p> MODELS WITHOUT POWER DOOR LOCKS ... 38</p> <p> MODELS WITH POWER DOOR LOCKS 39</p> <p>Trouble Diagnoses 40</p> <p> SYMPTOM CHART 40</p> <p> POWER SUPPLY AND GROUND CIRCUIT CHECK 41</p> <p> LIGHTING SWITCH INPUT SIGNAL CHECK ... 42</p> <p> KEY SWITCH (INSERTED) CHECK 42</p> <p> SEAT BELT BUCKLE SWITCH LH CHECK 44</p> <p> FRONT DOOR SWITCH LH CHECK 45</p>
--	--

D
E
F
G
H
I
J
DI
L
M

PRECAUTIONS

PRECAUTIONS

PFP:00001

Precautions for Supplemental Restraint System (SRS) “AIR BAG” and “SEAT BELT PRE-TENSIONER”

EKS006W2

The Supplemental Restraint System such as “AIR BAG” and “SEAT BELT PRE-TENSIONER”, used along with a front seat belt, helps to reduce the risk or severity of injury to the driver and front passenger for certain types of collision. This system may include seat belt switch inputs and dual stage front air bag modules. If equipped with dual stage front air bag modules, the SRS system uses the seat belt switches to determine the front air bag deployment, and may only deploy one front air bag, depending on the severity of a collision and whether the front occupants are belted or unbelted. Information necessary to service the system safely is included in the SRS and SB section of this Service Manual.

The vehicle may be equipped with a passenger air bag deactivation switch. Because no rear seat exists where a rear-facing child restraint can be placed, the switch is designed to turn off the passenger air bag so that a rear-facing child restraint can be used in the front passenger seat. The switch is located in the center of the instrument panel, near the ashtray. When the switch is turned to the ON position, the passenger air bag is enabled and could inflate for certain types of collision. When the switch is turned to the OFF position, the passenger air bag is disabled and will not inflate. A passenger air bag OFF indicator on the instrument panel lights up when the passenger air bag is switched OFF. The driver air bag always remains enabled and is not affected by the passenger air bag deactivation switch.

WARNING:

- To avoid rendering the SRS inoperative, which could increase the risk of personal injury or death in the event of a collision which would result in air bag inflation, all maintenance must be performed by an authorized NISSAN/INFINITI dealer.
- Improper maintenance, including incorrect removal and installation of the SRS, can lead to personal injury caused by unintentional activation of the system. For removal of Spiral Cable and Air Bag Module, see the SRS section.
- Do not use electrical test equipment on any circuit related to the SRS unless instructed to in this Service Manual. SRS wiring harnesses can be identified by yellow and/or orange harnesses or harness connectors.
- The vehicle may be equipped with a passenger air bag deactivation switch which can be operated by the customer. When the passenger air bag is switched OFF, the passenger air bag is disabled and will not inflate. When the passenger air bag is switched ON, the passenger air bag is enabled and could inflate for certain types of collision. After SRS maintenance or repair, make sure the passenger air bag deactivation switch is in the same position (ON or OFF) as when the vehicle arrived for service.

Wiring Diagrams and Trouble Diagnosis

EKS006W3

When you read wiring diagrams, refer to the following:

- [GI-13, "How to Read Wiring Diagrams"](#)
- [PG-9, "POWER SUPPLY ROUTING"](#)

When you perform trouble diagnosis, refer to the following:

- [GI-9, "HOW TO FOLLOW TEST GROUPS IN TROUBLE DIAGNOSES"](#)
- [GI-25, "How to Perform Efficient Diagnosis for an Electrical Incident"](#)

Check for any Service bulletins before servicing the vehicle.

METERS AND GAUGES

Component Parts and Harness Connector Location

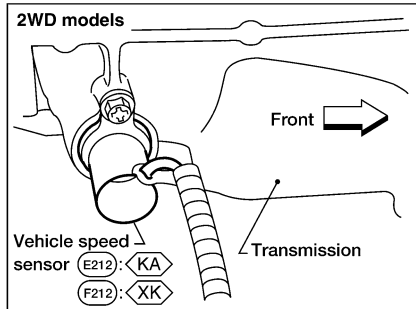
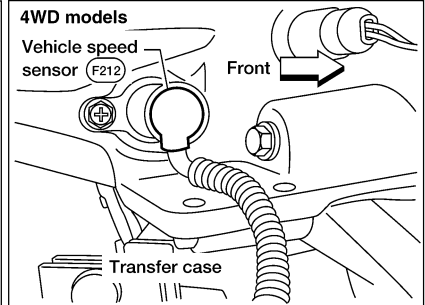
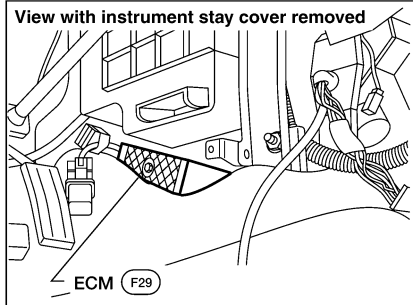
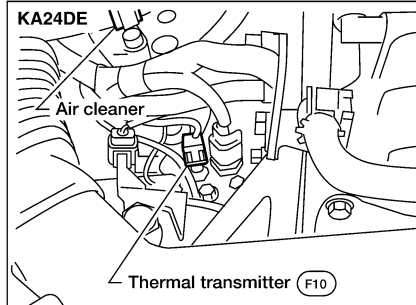
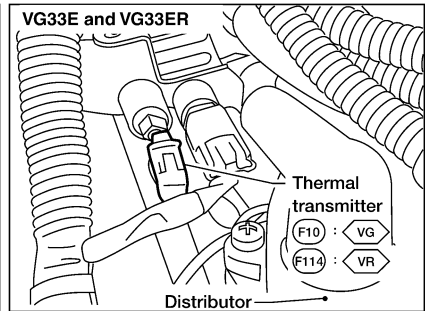
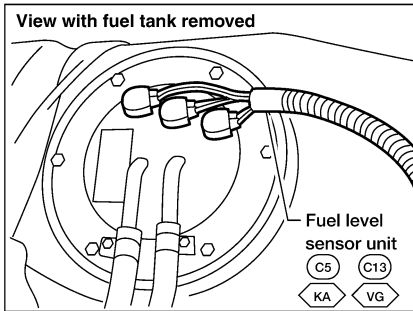
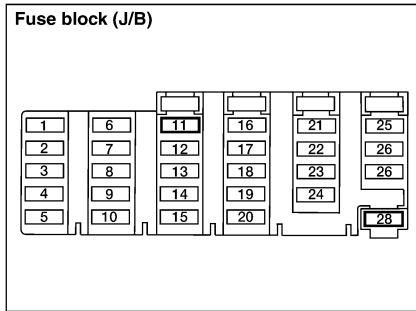

- KA : With KA24DE
- VG : With VG33E
- VR : With VG33ER
- XK : Except KA24DE

A
B
C
D
E
F
G
H
I
J
DI
L
M

DI

METERS AND GAUGES

EKS006W5

System Description UNIFIED CONTROL METER

- Speedometer, odo/trip meter, tachometer, fuel gauge and water temperature gauge are controlled by the unified meter control unit.
- Digital meter is adopted for odo/trip meter.*
*The record of the odometer is kept even if the battery cable is disconnected. The record of the trip meter is erased when the battery cable is disconnected.
- Odo/trip meter segment can be checked in diagnosis mode.
- Meter/gauge can be checked in diagnosis mode.

HOW TO CHANGE THE DISPLAY FOR ODO/TRIP METER

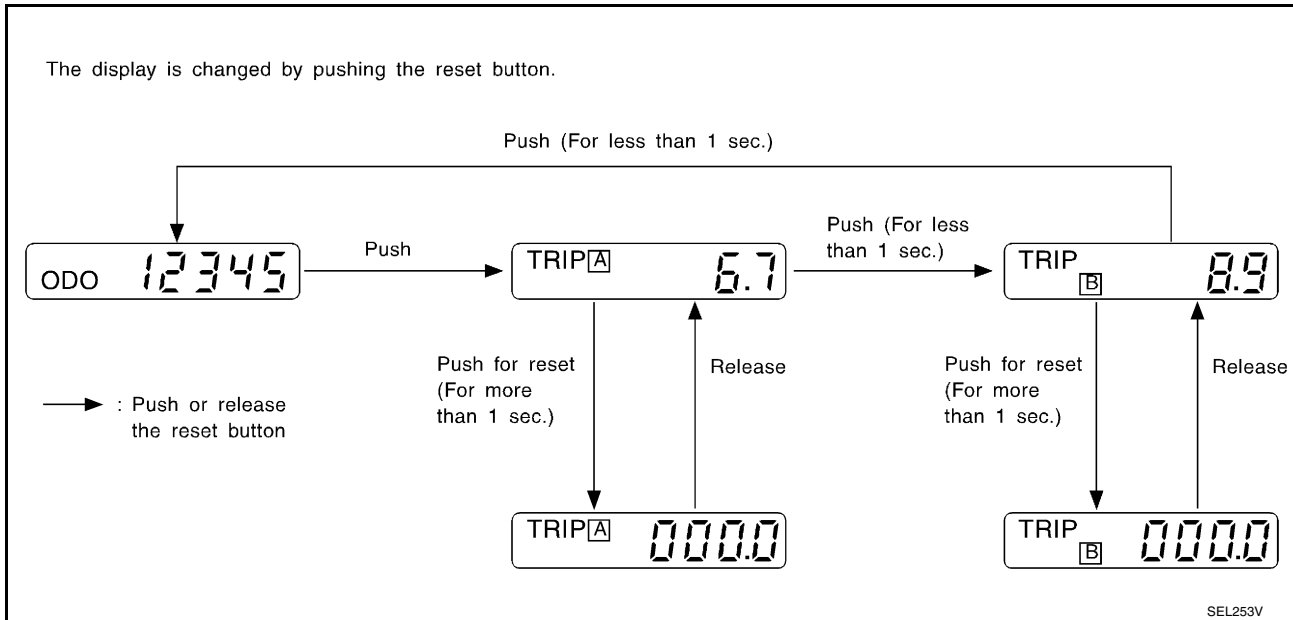

NOTE:

Turn the ignition switch ON to operate odo/trip meter.

POWER SUPPLY AND GROUND CIRCUIT

Power is supplied at all times

- through 7.5A fuse [No. 28, located in the fuse block (J/B)]
- to combination meter terminal 31.

With the ignition switch in the ON or START position, power is supplied

- through 10A fuse [No. 11, located in the fuse block (J/B)]
- to combination meter terminal 32.

Ground is supplied

- to combination meter terminal 33
- through body grounds M14 and M68.

FUEL GAUGE

The fuel gauge indicates the approximate fuel level in the fuel tank. The reading on the gauge is based on the resistance of the fuel level sensor unit.

The fuel gauge is regulated by a variable ground signal supplied

- to combination meter terminal 47 for the fuel gauge
- through fuel level sensor unit terminal G (with VG33E and VG33ER) or 1 (with KA24DE)
- through fuel level sensor unit terminal E (with VG33E and VG33ER) or 4 (with KA24DE)
- through body grounds M14 and M68.

WATER TEMPERATURE GAUGE

The water temperature gauge indicates the engine coolant temperature. The reading on the gauge is based on the resistance of the thermal transmitter.

METERS AND GAUGES

The water temperature gauge is regulated by a variable ground signal supplied

- to combination meter terminal 46
- through thermal transmitter terminal 1.

As the temperature of the coolant increases, the resistance of the thermal transmitter decreases and the needle on the gauge moves from C to H.

TACHOMETER

The tachometer indicates engine speed in revolutions per minute (rpm).

The tachometer is regulated by a signal

- to combination meter terminal 48 for the tachometer
- from ECM terminal 3.

SPEEDOMETER

The vehicle speed sensor provides a voltage signal to the combination meter for the speedometer.

The voltage is supplied

- to combination meter terminals 34 and 35
- from vehicle speed sensor terminals 1 and 2.

The unified meter control unit converts the voltage to the vehicle speed and displays it on the speedometer.

A

B

C

D

E

F

G

H

I

J

DI

L

M

METERS AND GAUGES

Combination Meter

EKS006W6

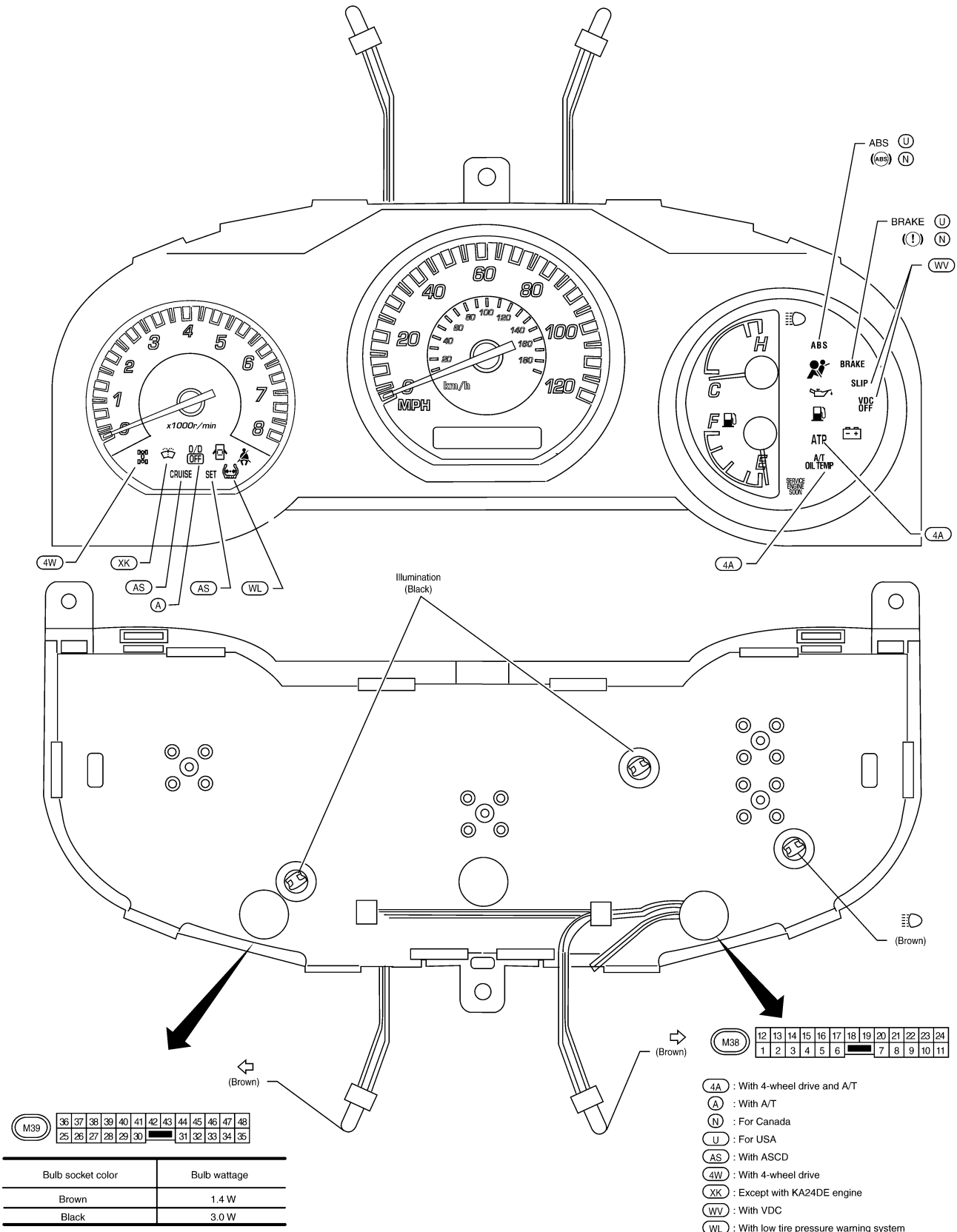

LKIA0144E

METERS AND GAUGES

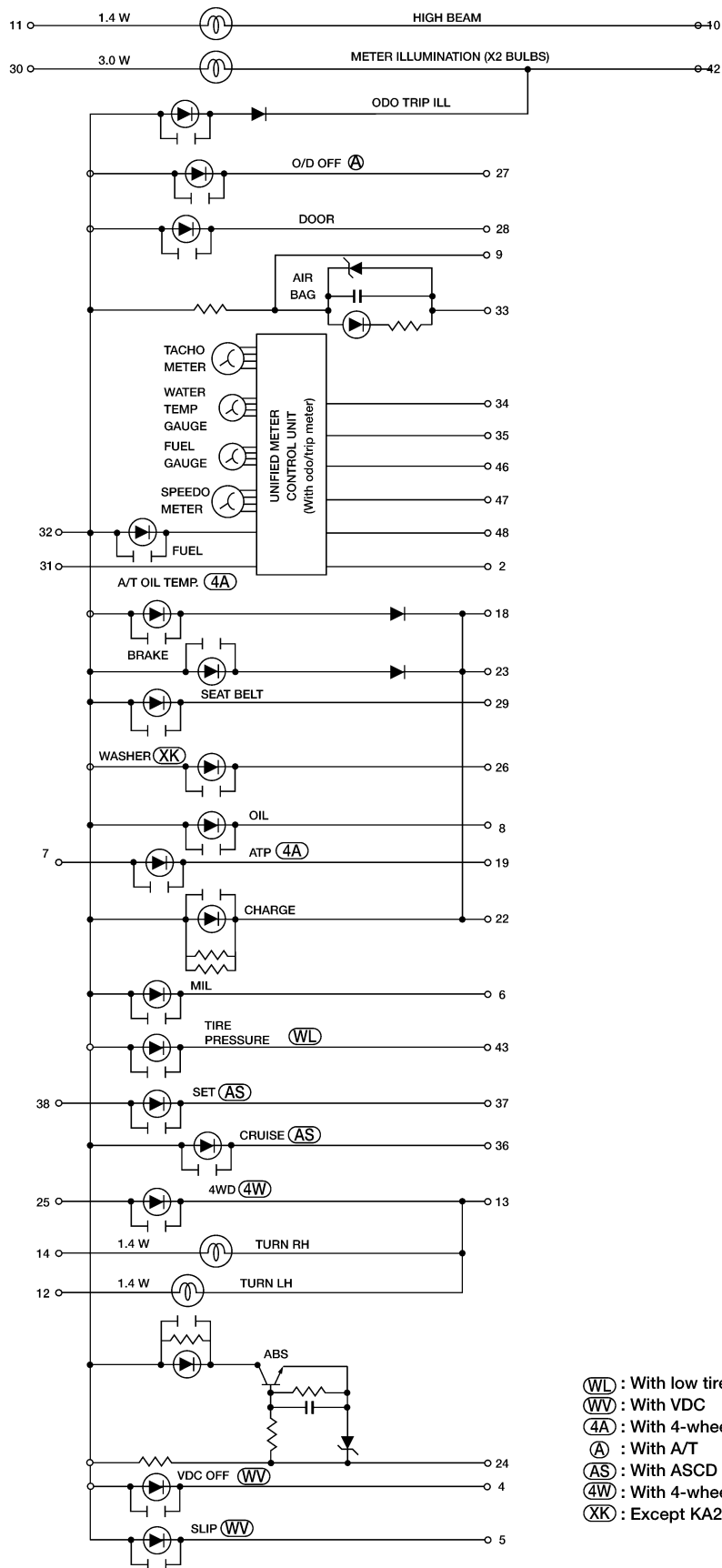

A
B
C
D
E
F
G
H
I
J
DI
L
M

- (WL) : With low tire pressure warning system
- (WV) : With VDC
- (4A) : With 4-wheel drive and A/T
- (A) : With A/T
- (AS) : With ASCD
- (4W) : With 4-wheel drive
- (XK) : Except KA24DE

WKWA0973E

METERS AND GAUGES

Wiring Diagram — METER —

EKS006W7

DI-METER-01

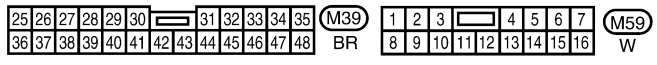
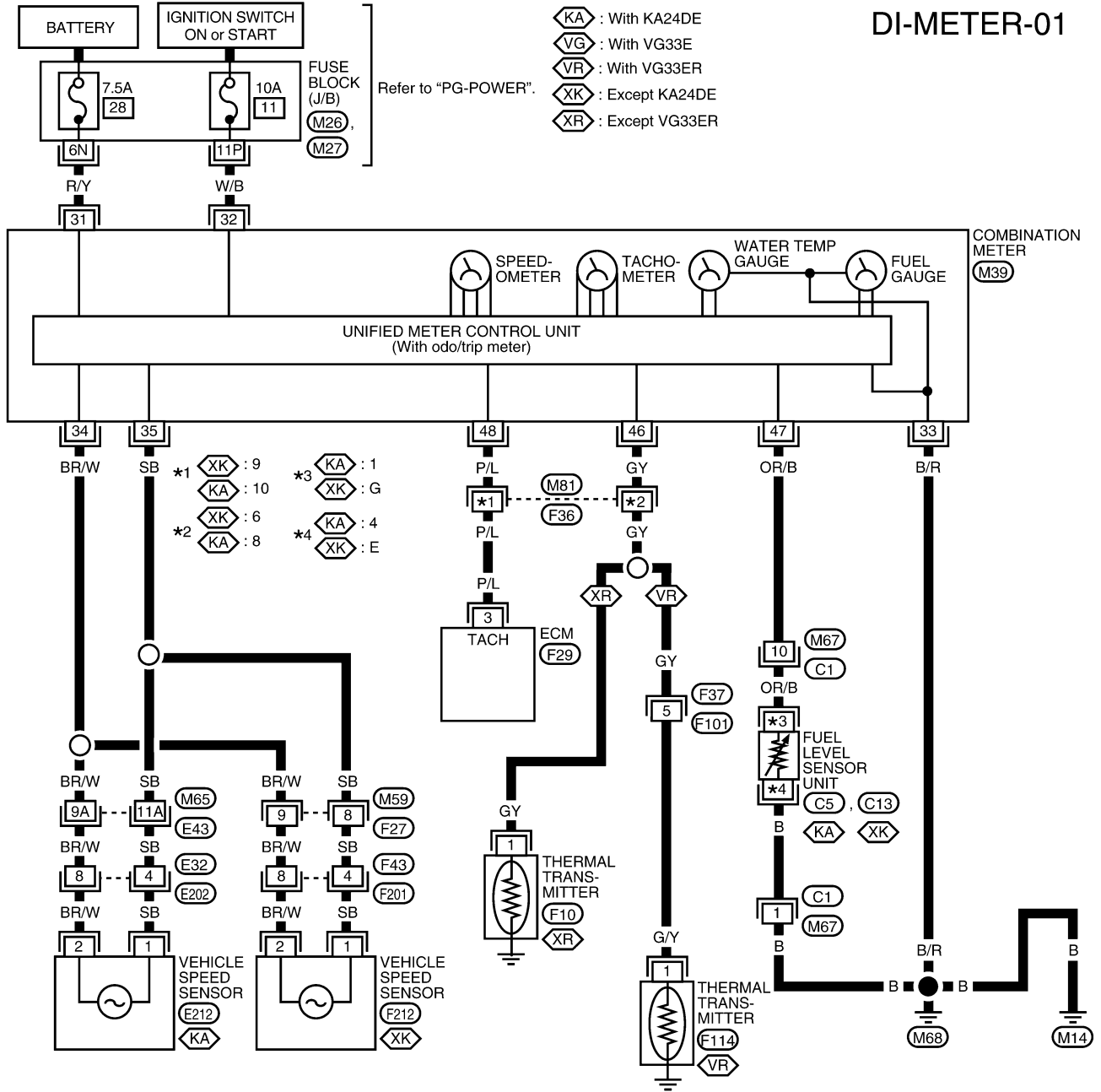

Refer to the following.

- E43 - SUPER MULTIPLE JUNCTION (SMJ)
- F29 - ELECTRICAL UNITS
- M26, M27 - FUSE BLOCK (J/B)

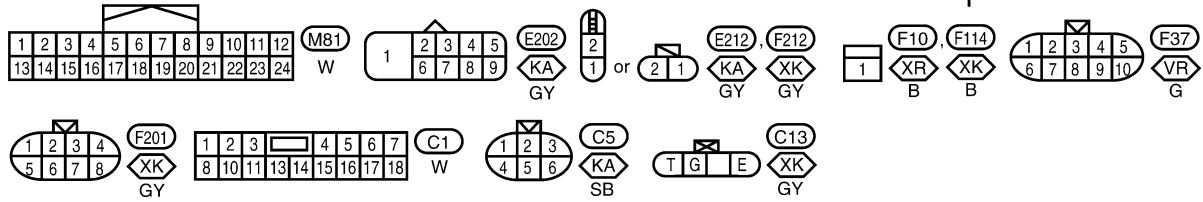

WKWA0974E

METERS AND GAUGES

Meter/Gauge Operation and Odo/Trip Meter Segment Check in Diagnosis Mode

EKS006W8

DIAGNOSIS FUNCTION

- Odo/trip meter segment can be checked in diagnosis mode.
- Meters/gauges can be checked in diagnosis mode.

HOW TO ALTERNATE DIAGNOSIS MODE

1. Turn ignition switch ON, while pressing and holding the trip reset switch for 0.8 second.
2. Push trip reset switch 3 times within 7 seconds.
3. All odo/trip meter segments should be turned on.

NOTE:

If some segments are not turned on, the combination meter should be replaced.

At this point, the combination meter is in diagnosis mode.

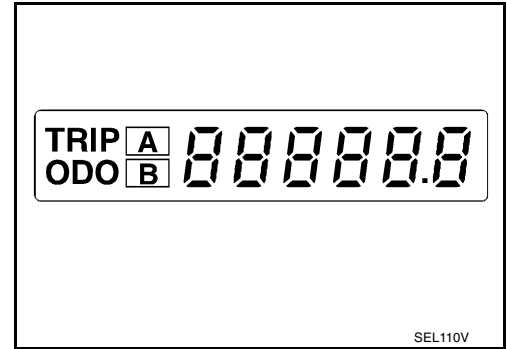

4. Push odo/trip meter switch. Indication of each meter/gauge should be as shown in figure at left while pushing odo/trip meter switch.

NOTE:

It takes about 1 minute for the fuel gauge indication to stabilize.

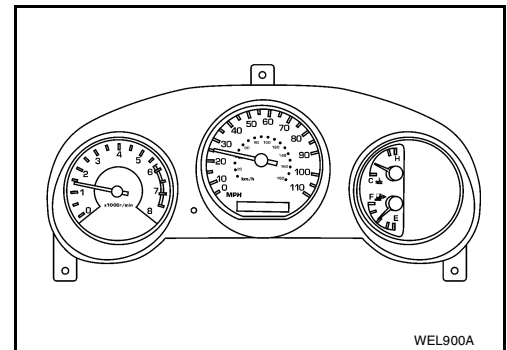

A
B
C
D
E
F
G
H
I
J
DI
L
M

METERS AND GAUGES

Trouble Diagnoses PRELIMINARY CHECK

EKS006W9

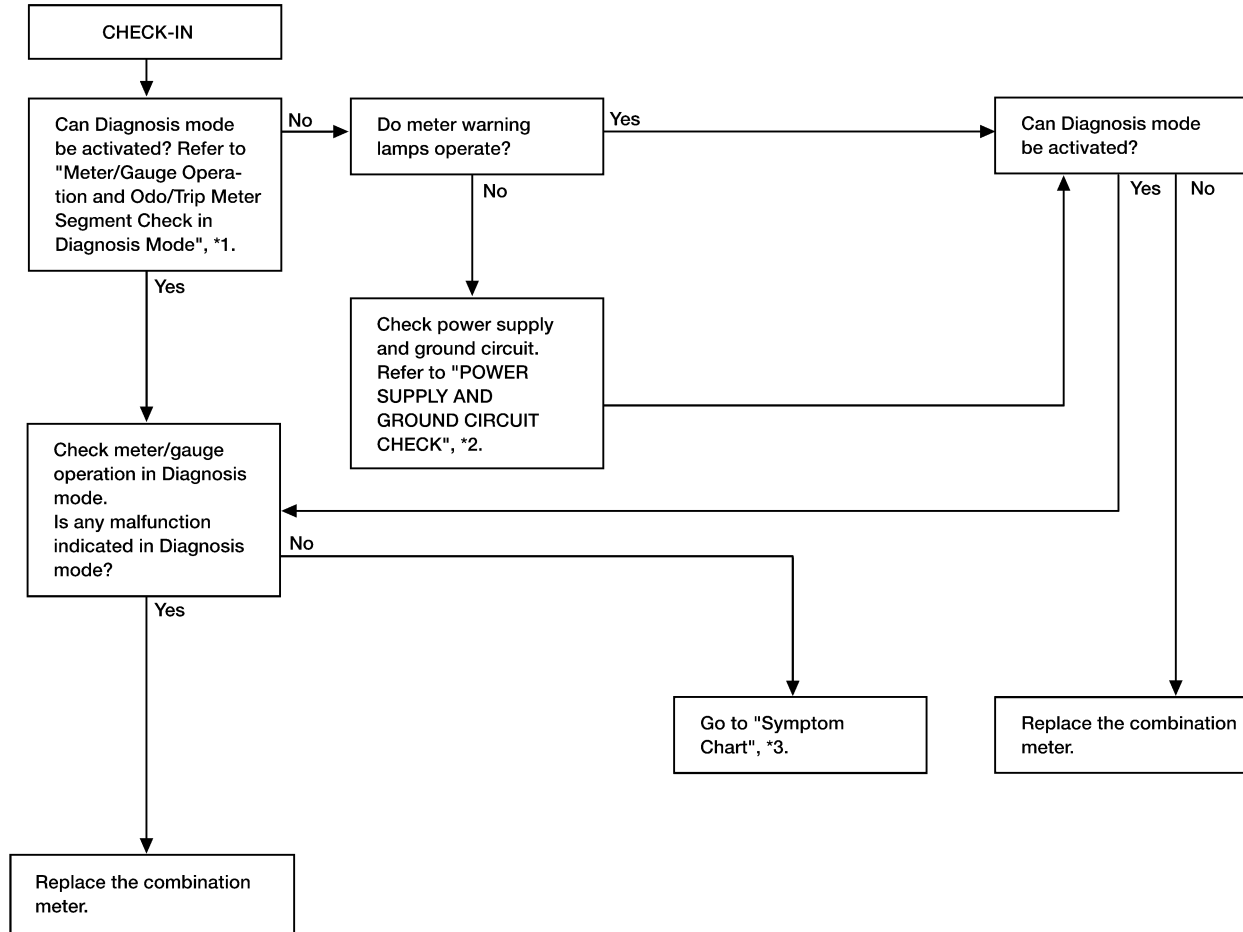

*1: [DI-9](#)

*2: [DI-12](#)

*3: [DI-11](#)

WEL835A

METERS AND GAUGES

SYMPTOM CHART

Symptom	Possible causes	Repair order
Speedometer and odo/trip meter are malfunctioning.	<ol style="list-style-type: none"> Signal <ul style="list-style-type: none"> Speedometer and odo/trip meter Unified meter control unit 	<ol style="list-style-type: none"> Check vehicle speed sensor. Refer to DI-13, "INSPECTION/VEHICLE SPEED SENSOR". Replace combination meter.
Multiple meters/gauges (except speedometer and odo/trip meter) are malfunctioning.	<ul style="list-style-type: none"> Unified meter control unit 	<ul style="list-style-type: none"> Replace combination meter.
One gauge (tachometer, fuel gauge, or water temp. gauge) is malfunctioning.	<ul style="list-style-type: none"> Unified meter control unit 	<ul style="list-style-type: none"> Replace combination meter.

Before starting trouble diagnoses above, perform [DI-10, "PRELIMINARY CHECK"](#).

A
B
C
D
E
F
G
H
I
J
DI
L
M

METERS AND GAUGES

POWER SUPPLY AND GROUND CIRCUIT CHECK

Power Supply Circuit Check

Terminals		(-)	Ignition switch position		
(+)			OFF	ACC	ON
Connector	Terminal (Wire color)	Ground			
M39	31 (R/Y)			Battery voltage	Battery voltage
M39	32 (W/B)		0V	0V	Battery voltage

If NG, check the following.

- 7.5A fuse [No. 28, located in fuse block (J/B)]
- 10A fuse [No. 11, located in fuse block (J/B)]
- Harness for open or short between fuse and combination meter

Ground Circuit Check

Terminals		(-)	Continuity
(+)			
Connector	Terminal (Wire color)	Ground	
M39	33 (B/R)		

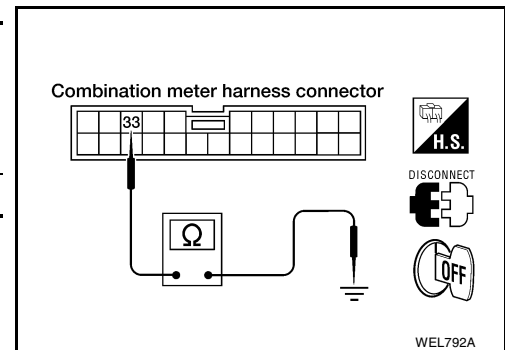
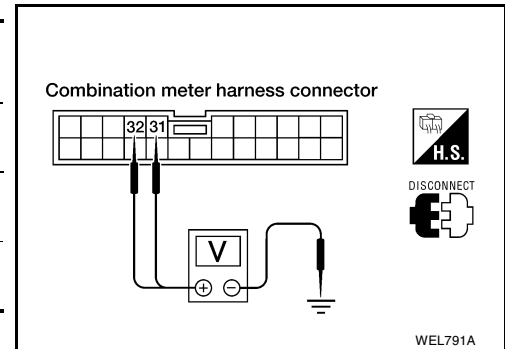

METERS AND GAUGES

INSPECTION/VEHICLE SPEED SENSOR

1. CHECK VEHICLE SPEED SENSOR OUTPUT

1. Remove vehicle speed sensor.
2. Check voltage between combination meter harness connector M39 terminals 34 (BR/W) and 35 (SB) while quickly turning vehicle speed sensor pinion.

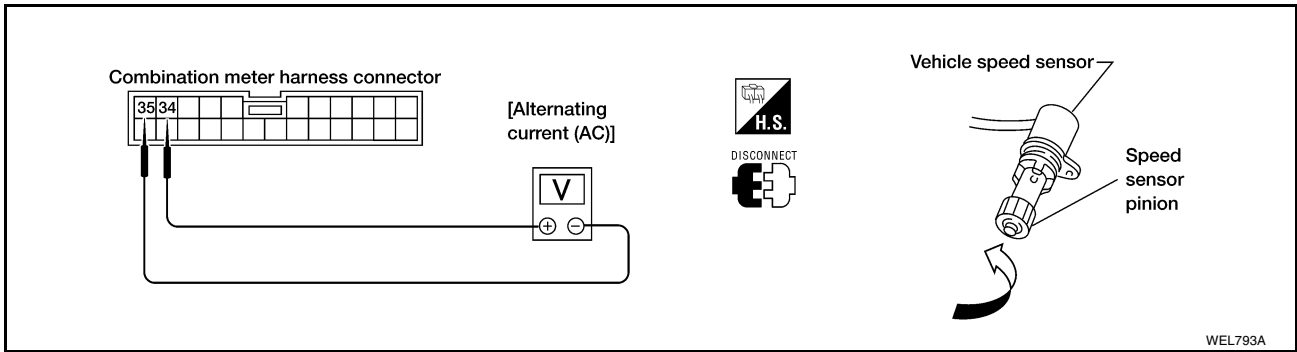

Voltage : Approx. 0.5V

OK or NG

- OK >> Vehicle speed sensor is OK.
- NG >> GO TO 2.

2. CHECK VEHICLE SPEED SENSOR

Check resistance between vehicle speed sensor connector E212 (KA24DE), F212 (VG33E/VG33ER) terminals 1 and 2.

Resistance : Approx. 285Ω

OK or NG

- OK >> Check harness and connector between speedometer and vehicle speed sensor.
- NG >> Replace vehicle speed sensor.

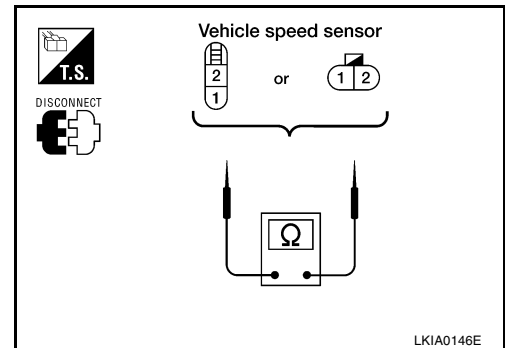

METERS AND GAUGES

INSPECTION/ENGINE REVOLUTION SIGNAL

1. CHECK ECM OUTPUT

1. Start engine.
2. Check voltage between combination meter harness connector M39 terminals 48 (P/L) and 33 (B/R) at idle and 2,000 rpm.

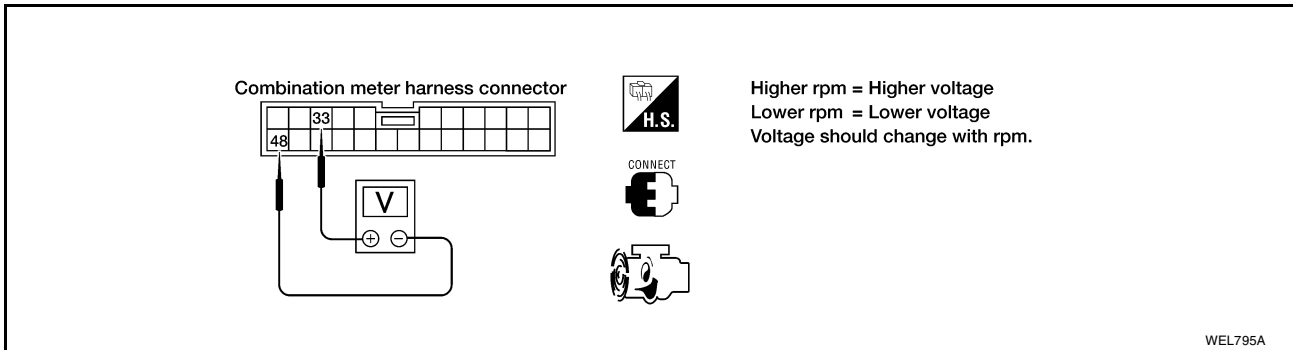

OK or NG

- OK >> Engine revolution signal is OK.
- NG >> Check harness for open or short between ECM and combination meter.

METERS AND GAUGES

INSPECTION/FUEL LEVEL SENSOR UNIT

1. CHECK GROUND CIRCUIT FOR FUEL LEVEL SENSOR UNIT

1. Disconnect fuel level sensor unit harness connector C5 (with KA24DE) or C13 (with VG33E and VG33ER).
2. With VG33E and VG33ER: Check harness continuity between fuel level sensor unit harness connector C13 terminal E (B) and ground.
With KA24DE: Check harness continuity between fuel level sensor unit harness connector C5 terminal 4 (B) and ground.

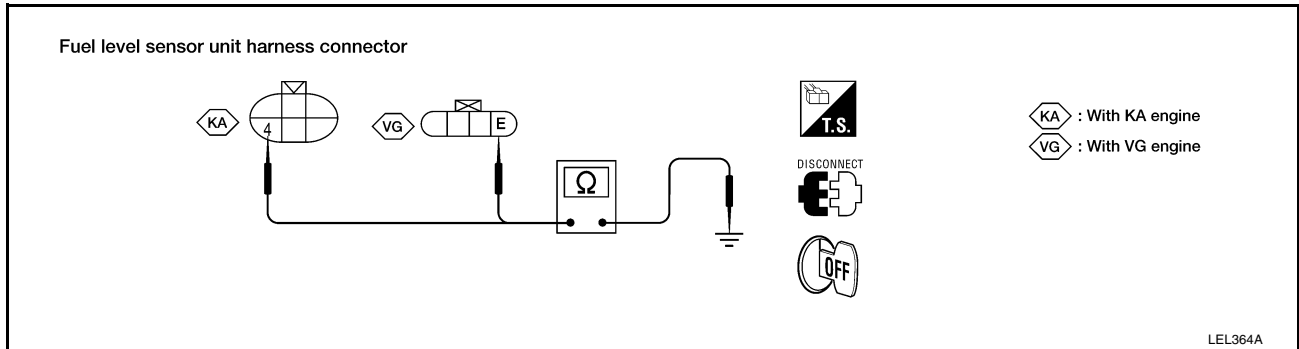

Continuity should exist.

OK or NG?

- OK >> GO TO 2.
- NG >> Repair harness or connector.

2. CHECK FUEL LEVEL SENSOR UNIT

Refer to [DI-18. "FUEL LEVEL SENSOR UNIT CHECK"](#) .

OK or NG

- OK >> GO TO 3.
- NG >> Replace fuel level sensor unit.

METERS AND GAUGES

3. CHECK HARNESS FOR OPEN OR SHORT

1. Disconnect combination meter harness connector M39, ECM harness connector F29, and fuel level sensor unit harness connector.
2. With VG33E and VG33ER: Check continuity between combination meter harness connector M39 terminal 47 (OR/B) and fuel level sensor unit harness connector C13 terminal G (OR/B).
With KA24DE: Check continuity between combination meter harness connector M39 terminal 47 (OR/B) and fuel level sensor unit harness connector C5 terminal 1 (OR/B).

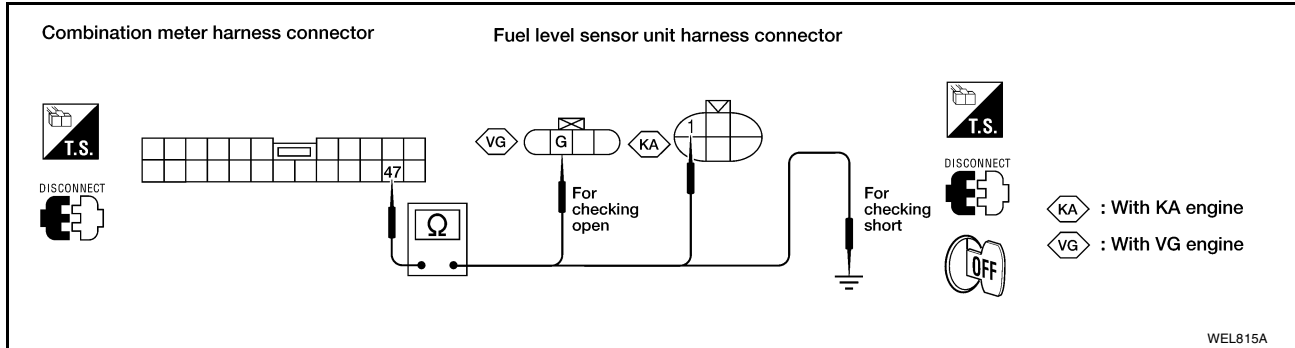

Continuity should exist.

3. Check continuity between combination meter harness connector M39 terminal 47 (OR/B) and ground.

Continuity should not exist.

OK or NG

- OK >> Fuel level sensor unit is OK.
- NG >> Repair harness or connector.

INSPECTION/THERMAL TRANSMITTER

1. CHECK THERMAL TRANSMITTER

Refer to [DI-18, "THERMAL TRANSMITTER CHECK"](#).

OK or NG

- OK >> GO TO 2.
- NG >> Replace thermal transmitter.

METERS AND GAUGES

2. CHECK HARNESS FOR OPEN OR SHORT

1. Disconnect combination meter harness connector M39 and thermal transmitter harness connector F10 (except VG33ER) or F114 (with VG33ER).
2. Check continuity between combination meter harness connector M39 terminal 46 (GY) and thermal transmitter harness connector F10 (except VG33ER) terminal 1 (GY) or F114 (with VG33ER) terminal 1 (G/Y).

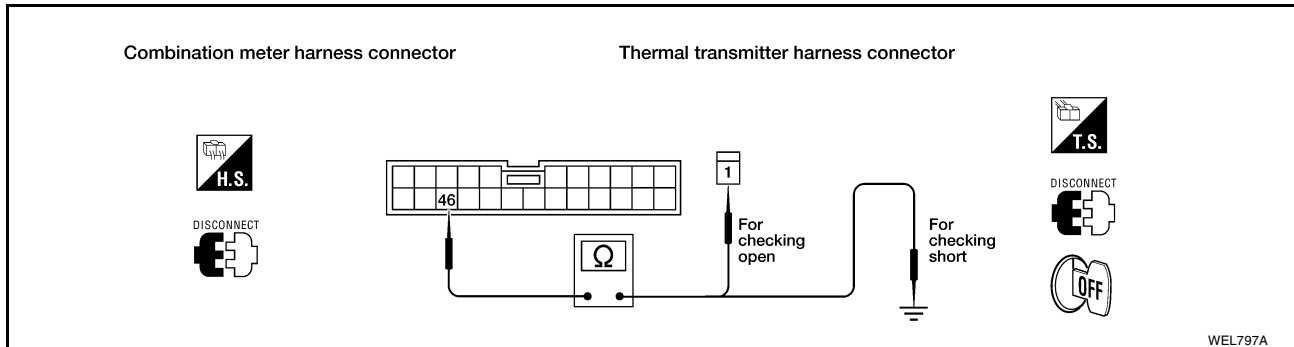

Continuity should exist.

3. Check continuity between combination meter harness connector M39 terminal 46 and ground.

Continuity should not exist.

OK or NG

- OK >> Thermal transmitter is OK.
- NG >> Repair harness or connector.

METERS AND GAUGES

EKS006WA

Electrical Components Inspection FUEL LEVEL SENSOR UNIT CHECK

- For removal, refer to [FL-6, "Removal and Installation"](#).

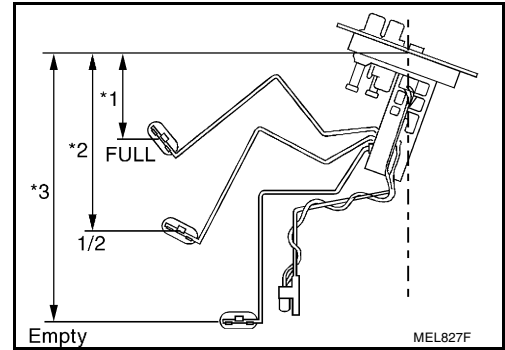

With KA24DE

Check the resistance between fuel level sensor unit terminals 1 and 4.

Ohmmeter		Float position mm (in)			Resistance value (Ω) (Approx.)
(+)	(-)				
1	4	*1	Full	96 (3.78)	4 - 6
		*2	1/2	188 (7.40)	30 - 34
		*3	Empty	257 (10.12)	80 - 83

*1 and *3: When float rod is in contact with stopper.

With VG33E and VG33ER

Check the resistance between fuel level sensor unit terminals G and E.

Ohmmeter		Float position mm (in)			Resistance value (Ω) (Approx.)
(+)	(-)				
G	E	*1	Full	96 (3.78)	4 - 6
		*2	1/2	188 (7.40)	30 - 34
		*3	Empty	257 (10.12)	80 - 83

*1 and *3: When float rod is in contact with stopper.

THERMAL TRANSMITTER CHECK

Check the resistance between thermal transmitter terminal 1 and body ground.

Water temperature	Resistance value (Ω) (Approx.)
60°C (140°F)	170 - 210Ω
100°C (212°F)	47 - 53Ω

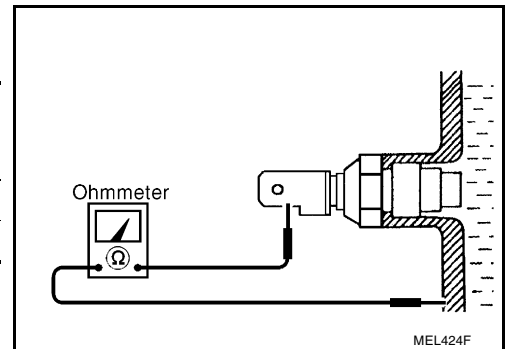

METERS AND GAUGES

VEHICLE SPEED SENSOR SIGNAL CHECK

1. Remove vehicle speed sensor.
2. Turn vehicle speed sensor pinion quickly and measure voltage across 1 and 2.

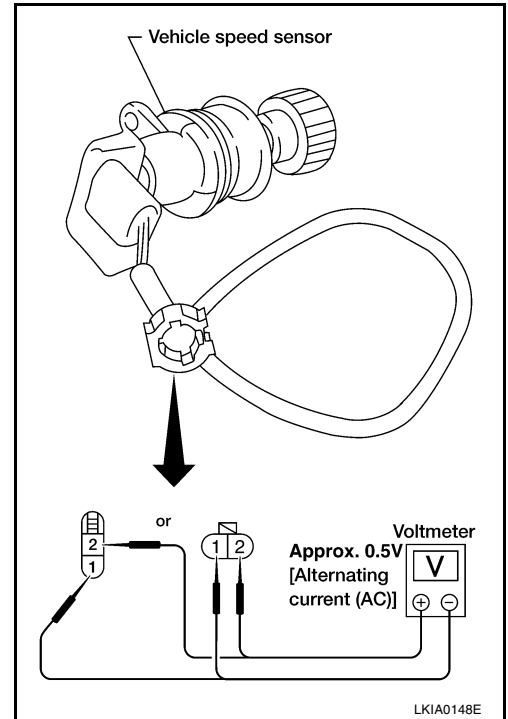

A
B
C
D
E
F
G
H
I
J
DI
L
M

COMPASS AND THERMOMETER

COMPASS AND THERMOMETER

PFP:24835

System Description

EKS006WB

The compass and thermometer unit displays following items:

- Earth magnetism and heading direction of vehicle.
- Outside air temperature.
- Caution for frozen road surfaces.

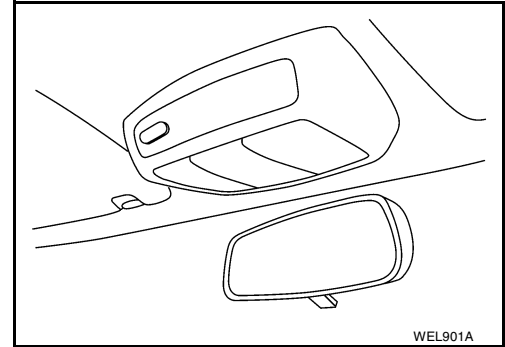

OUTSIDE TEMPERATURE DISPLAY

Push the mode switch when the ignition switch is in the ON position. The outside temperature will be displayed in “°F”.

- Selecting the indication range
Push the switch to change from “°F” to “°C”.
- The indicated temperature on the thermometer is not readily affected by engine heat. It changes only when one of the following conditions is present.
 - The temperature detected by the ambient air temperature sensor is lower than the indicated temperature on the thermometer.
 - The vehicle speed is greater than 20 km/h (13 MPH).
(This is to prevent the indicated temperature from being affected by engine heat during low-speed driving.)
 - The ignition switch has been turned to the OFF position for more than 2 hours. (The engine is cold.)

DIRECTION DISPLAY

Push the switch with the ignition switch in the ON position. The direction will be displayed.

COMPASS AND THERMOMETER

CREW CAB

DI-COMPAS-02

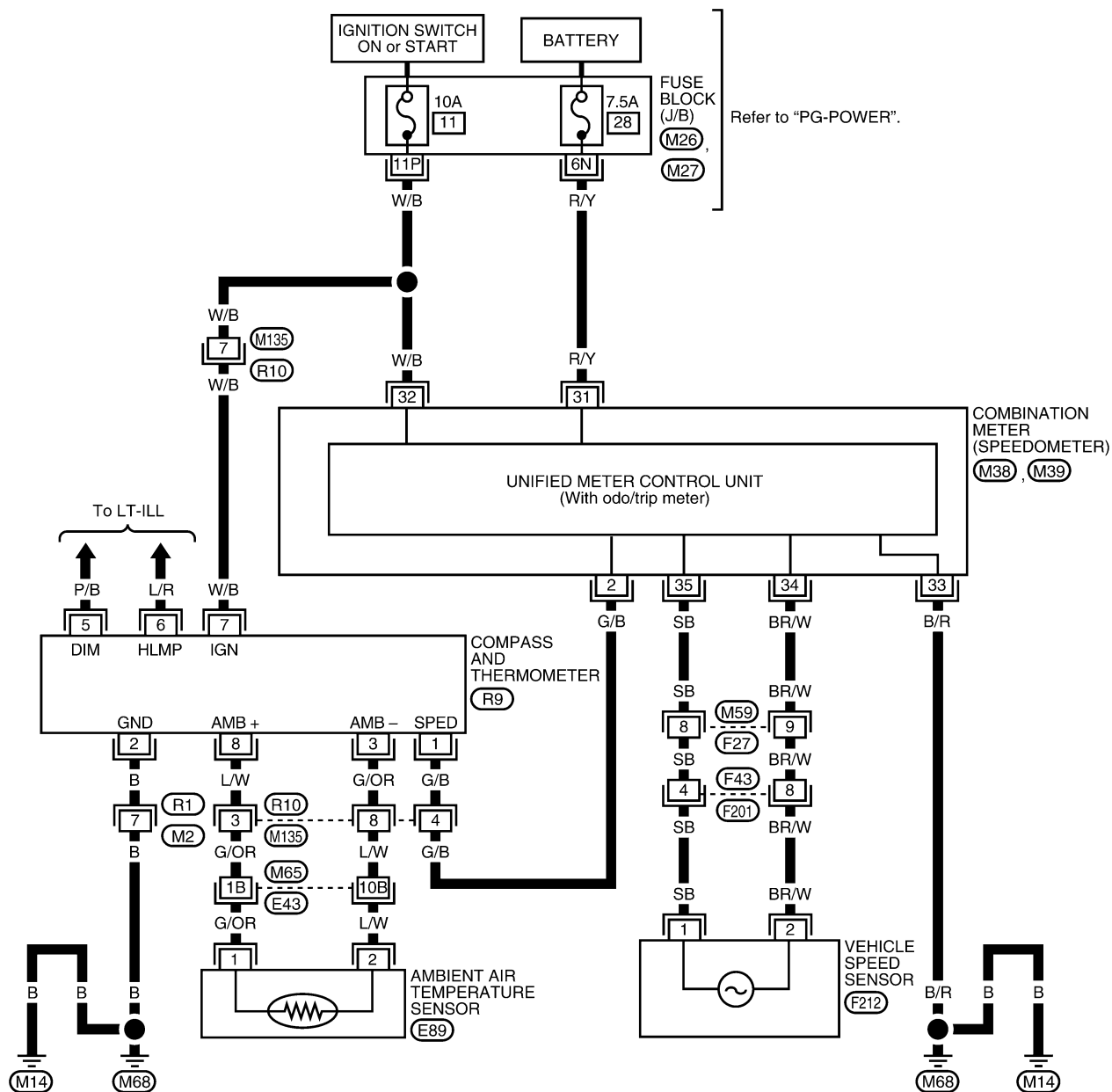

Refer to "PG-POWER".

COMBINATION METER (SPEEDOMETER) (M38), (M39)

COMPASS AND THERMOMETER (R9)

VEHICLE SPEED SENSOR (F212)

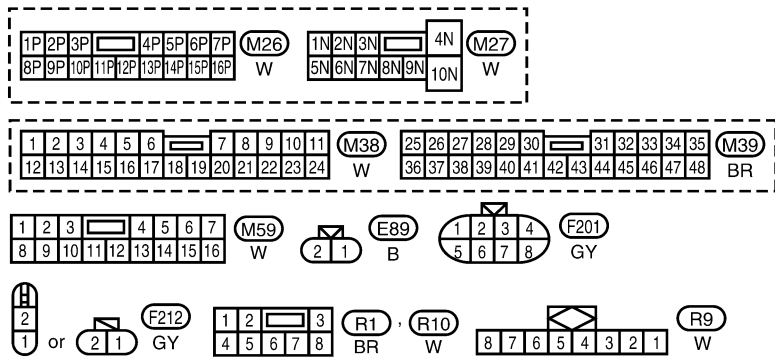

Refer to the following.
 (E43) - SUPER MULTIPLE JUNCTION (SMJ)

COMPASS AND THERMOMETER

EKS006WD

Trouble Diagnoses PRELIMINARY CHECK FOR THERMOMETER

1. COOL DOWN CHECK

1. Turn the ignition switch to the ON position.
2. Cool down the ambient air temperature sensor with water or ice, so that the indicated temperature drops.

Does the indicated temperature drop?

Yes >> GO TO 2.

No >> The system is malfunctioning. Check the system following "INSPECTION/COMPASS AND THERMOMETER". Refer to [DI-23, "INSPECTION/COMPASS AND THERMOMETER"](#).

2. WARM UP CHECK

1. Leave the vehicle for 10 minutes, so that the indicated temperature rises.
2. With the ignition switch in the ON position, disconnect and reconnect the ambient air temperature sensor connector.

Does the indicated temperature rise?

Yes >> The system is OK.

No >> The system is malfunctioning. Check the system following "INSPECTION/COMPASS AND THERMOMETER". Refer to [DI-23, "INSPECTION/COMPASS AND THERMOMETER"](#).

NOTE:

- The indicated temperature on the thermometer is not readily affected by engine heat. It changes only when one of the following conditions is present.
 - The temperature detected by the ambient air temperature sensor is lower than the indicated temperature on the thermometer.
 - The vehicle speed is greater than 20 km/h (13 MPH).
(This is to prevent the indicated temperature from being affected by engine heat during low-speed driving.)
 - The ignition switch has been turned to the OFF position for more than 2 hours. (The engine is cold.)

INSPECTION/COMPASS AND THERMOMETER

Symptom	Possible causes	Repair order
No display at all	1. 10A fuse 2. Ground circuit 3. Compass and thermometer	1. Check 10A fuse [No. 11, located in fuse block (J/B)]. Turn the ignition switch ON and verify that battery positive voltage is at terminal 7 of compass and thermometer. 2. Check ground circuit for compass and thermometer. 3. Replace compass and thermometer.
Forward direction indication slips off the mark or incorrect.	1. In manual correction mode (Bar and display vanish.) 2. Zone variation change is not done.	1. Drive the vehicle and turn at an angle of 90°. 2. Perform the zone variation change.
Compass reading remains unchanged.	1. Vehicle speed signal is not entered. 2. Compass and thermometer	1. Check harness for open or short between combination meter terminal 2 and compass and thermometer terminal 1. 2. Replace compass and thermometer.
Displays wrong temperature when ambient temperature is between -40°C (-40°F) and 55°C (130°F). (See NOTE above.)	1. Check operation 2. Ambient air temperature sensor circuit 3. Vehicle speed signal is not entered. 4. Ambient air temperature sensor 5. Compass and thermometer	1. Perform preliminary check shown above. 2. Check harness for open or short between ambient air temperature sensor and compass and thermometer. 3. Check harness for open or short between combination meter terminal 2 and compass and thermometer terminal 1. 4. Replace ambient air temperature sensor. 5. Replace compass and thermometer.
Displays SC or OC.	1. Ambient air temperature sensor circuit. 2. Ambient air temperature sensor. 3. Compass and thermometer.	1. Check harness for open or short between ambient air temperature sensor and compass and thermometer. 2. Replace ambient air temperature sensor. 3. Replace compass and thermometer.

COMPASS AND THERMOMETER

EKS006WE

Calibration Procedure for Compass

The difference between magnetic North and geographical North can sometimes be great enough to cause false compass readings. In order for the compass to operate accurately in a particular zone, it must be calibrated using the following procedure.

Zone Variation Chart

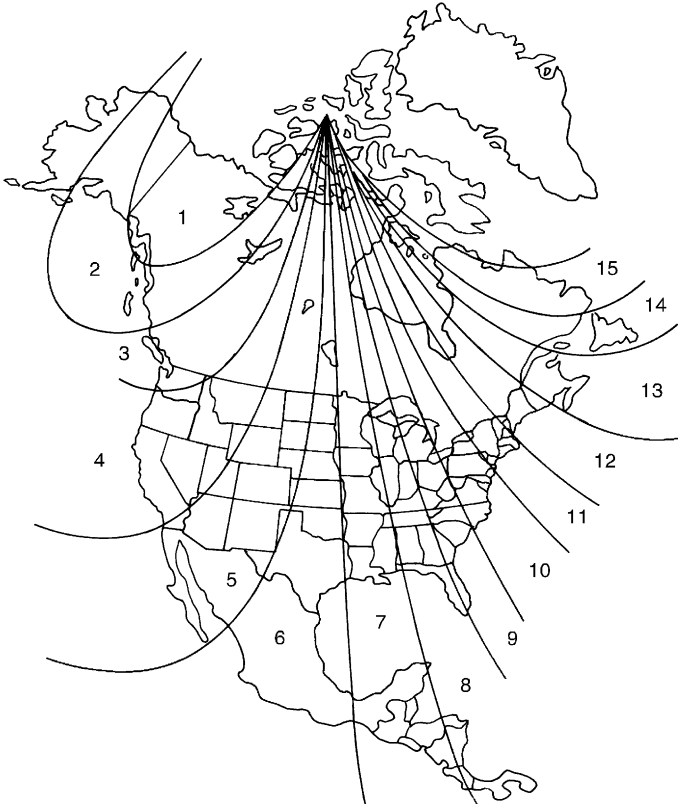

The chart shows 15 numbered zones radiating from the North Pole. Zone 1 is the northernmost, and zone 15 is the southernmost. The zones are numbered 1 through 15, with zone 5 covering the Hawaiian Islands.

1. Determine your location on the zone map. Record your zone number.
2. Turn the ignition switch to the ON position.
3. Push the "Mode" switch continuously for five seconds until the current zone entry number and the "VAR" icon is displayed.
4. Press the "Mode" switch repeatedly until the desired zone number is displayed.

Once the desired zone number is displayed, stop pressing the "Mode" switch and the display will show compass direction after a few seconds.

NOTE: Use zone number 5 for Hawaii.

WEL859A

CORRECTION FUNCTIONS OF COMPASS

The direction display is equipped with automatic correction function. If the direction is not shown correctly, carry out initial correction.

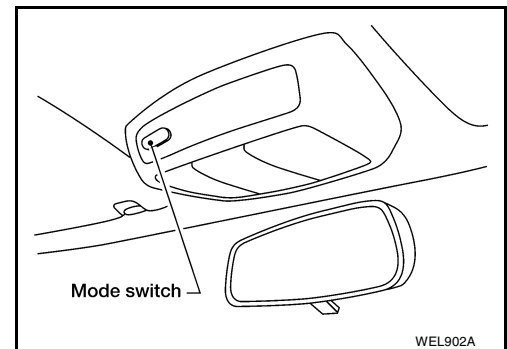

INITIAL CORRECTION PROCEDURE FOR COMPASS

1. Pushing the Mode switch for about 10 seconds will enter the initial correction mode. The "CAL" icon will illuminate.
2. Turn the vehicle slowly in an open, safe place. The initial correction is completed in one or two turns.

NOTE:

In places where the terrestrial magnetism is extremely disturbed, the initial correction may start automatically.

WARNING LAMPS

WARNING LAMPS

Circuit Diagram

PF0:24814

EKS006WF

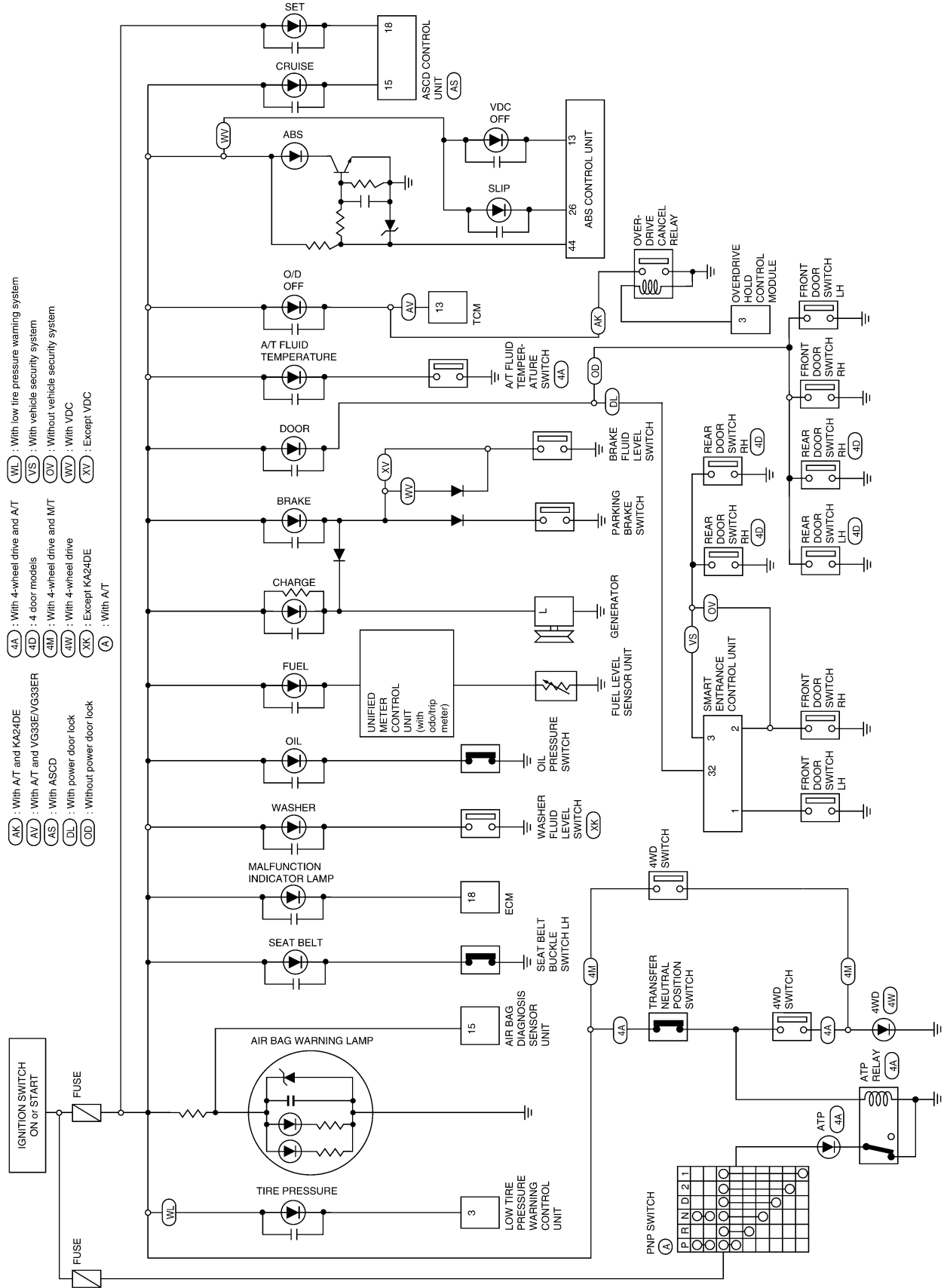

A
B
C
D
E
F
G
H
I
J
K
L
M

DI

WARNING LAMPS

DI-WARN-02

- DL : With power door locks
- KA : With KA24DE
- OD : Without power door locks
- WV : With VDC
- XK : Except KA24DE
- *1 KA : 6
- *1 XK : 4
- *2 KA : 1
- *2 XK : G
- *3 KA : 4
- *3 XK : E

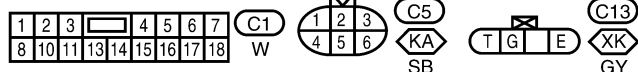
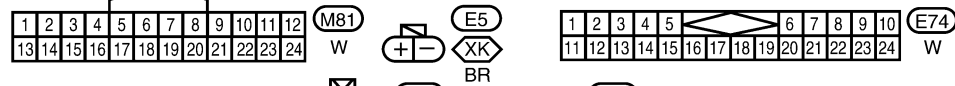
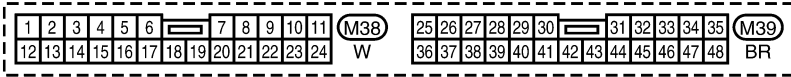
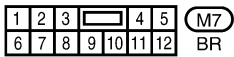
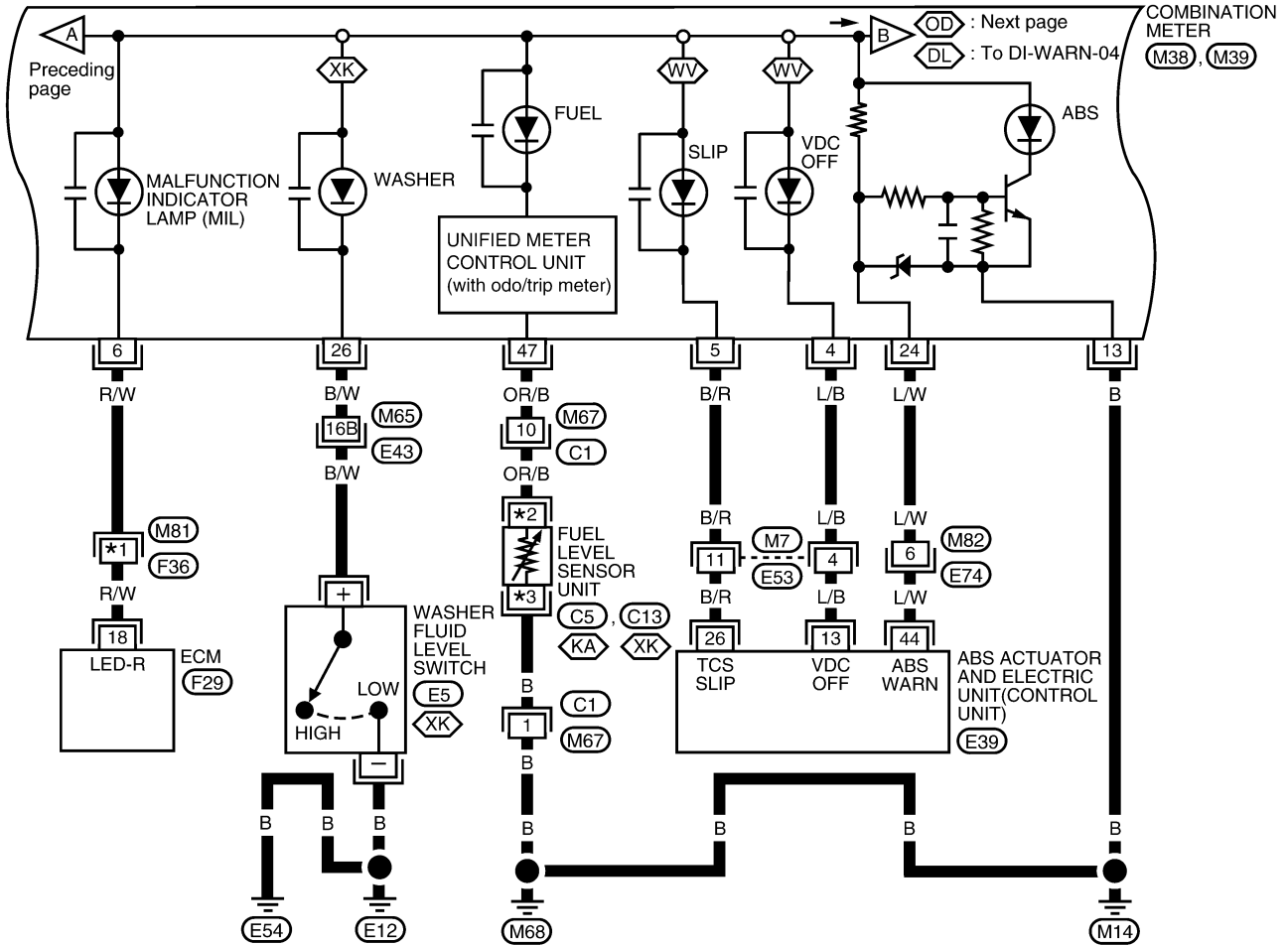

Refer to the following.

- E43 - SUPER MULTIPLE JUNCTION (SMJ)
- E39, F29 - ELECTRICAL UNITS

WKWA0976E

WARNING LAMPS

MODELS WITHOUT POWER DOOR LOCKS

DI-WARN-03

4D : 4 door models

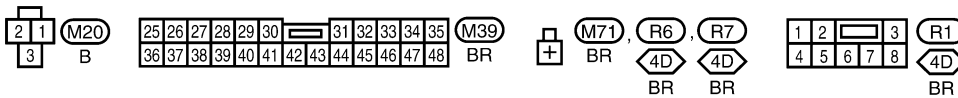
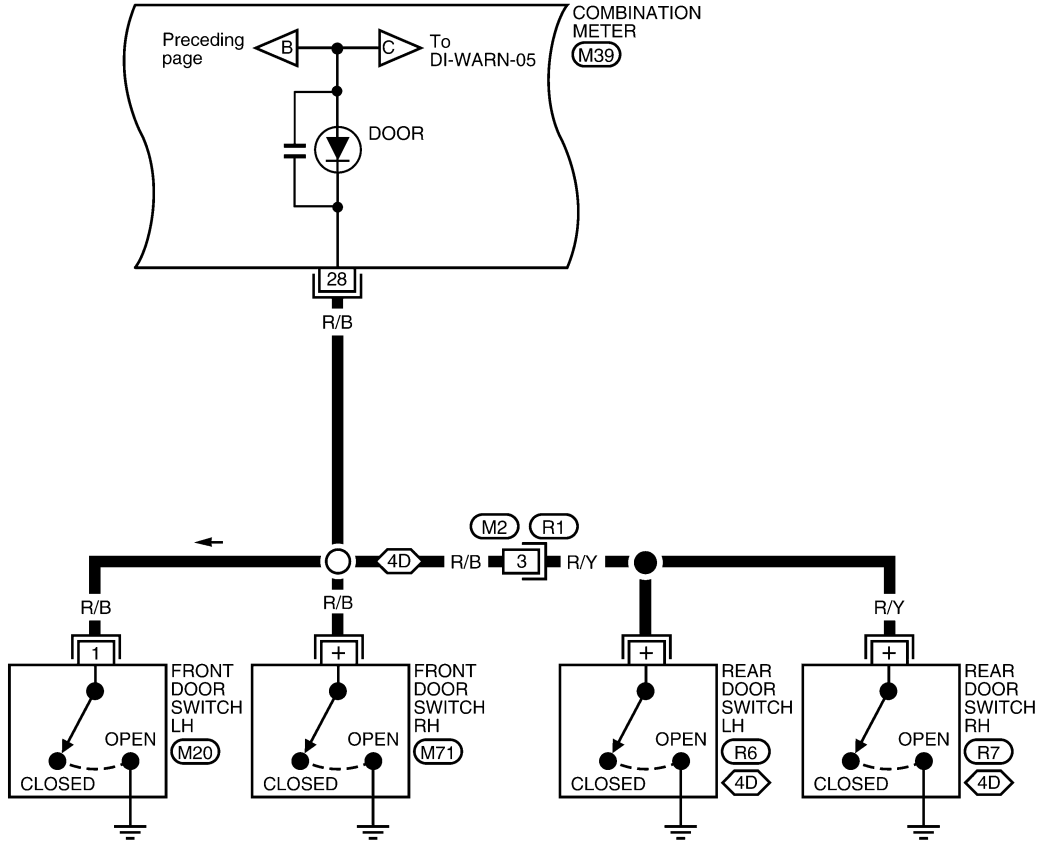

WARNING LAMPS

MODELS WITH POWER DOOR LOCKS

DI-WARN-04

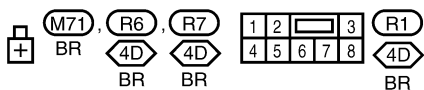
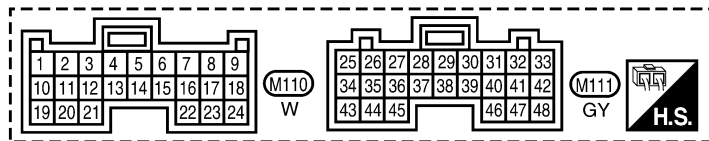
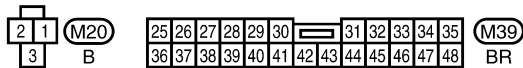
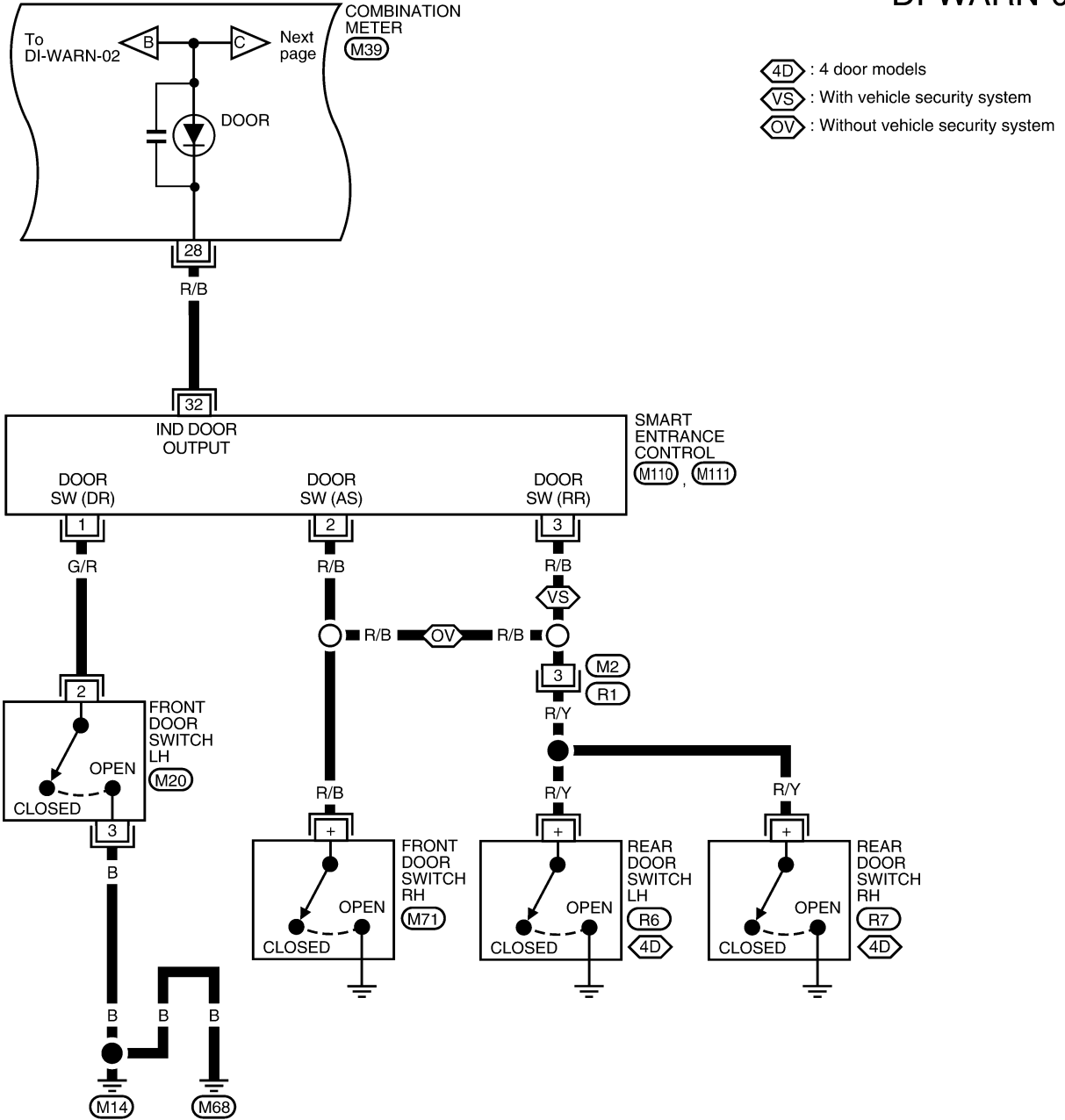

WARNING LAMPS

DI-WARN-05

WV : With VDC KA : With KA24DE
XV : Except VDC XK : Except KA24DE

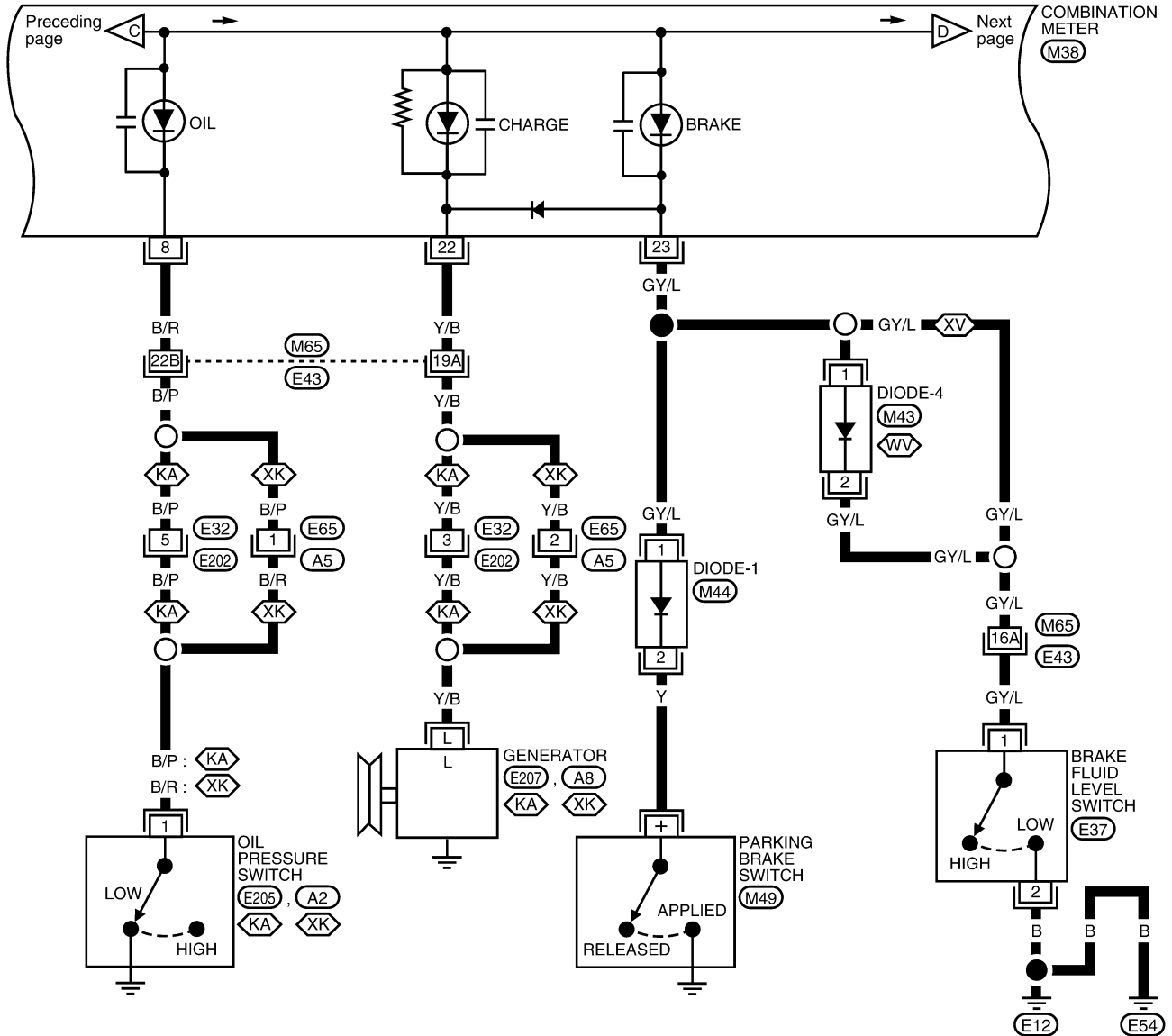

1	2	3	4	5	6	7	8	9	10	11	M38		
12	13	14	15	16	17	18	19	20	21	22	23	24	W

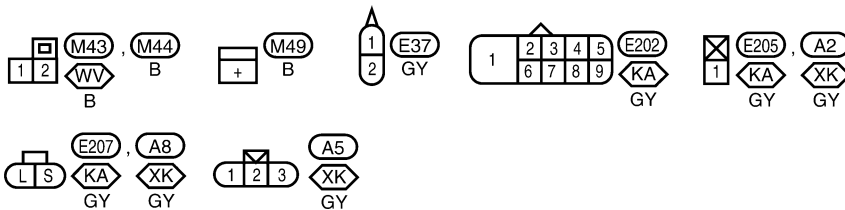

Refer to the following.
M65, E43 - SUPER
 MULTIPLE JUNCTION (SMJ)

LKWA0110E

WARNING LAMPS

DI-WARN-06

- (AK) : With A/T and KA24DE
- (AV) : With A/T and VG33E/VG33ER
- (AS) : With ASCD
- (4A) : With 4-wheel drive and A/T

- (KA) : With KA24DE
- (XK) : Except KA24DE

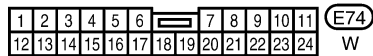
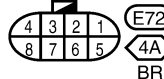
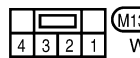
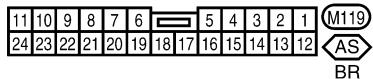
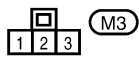
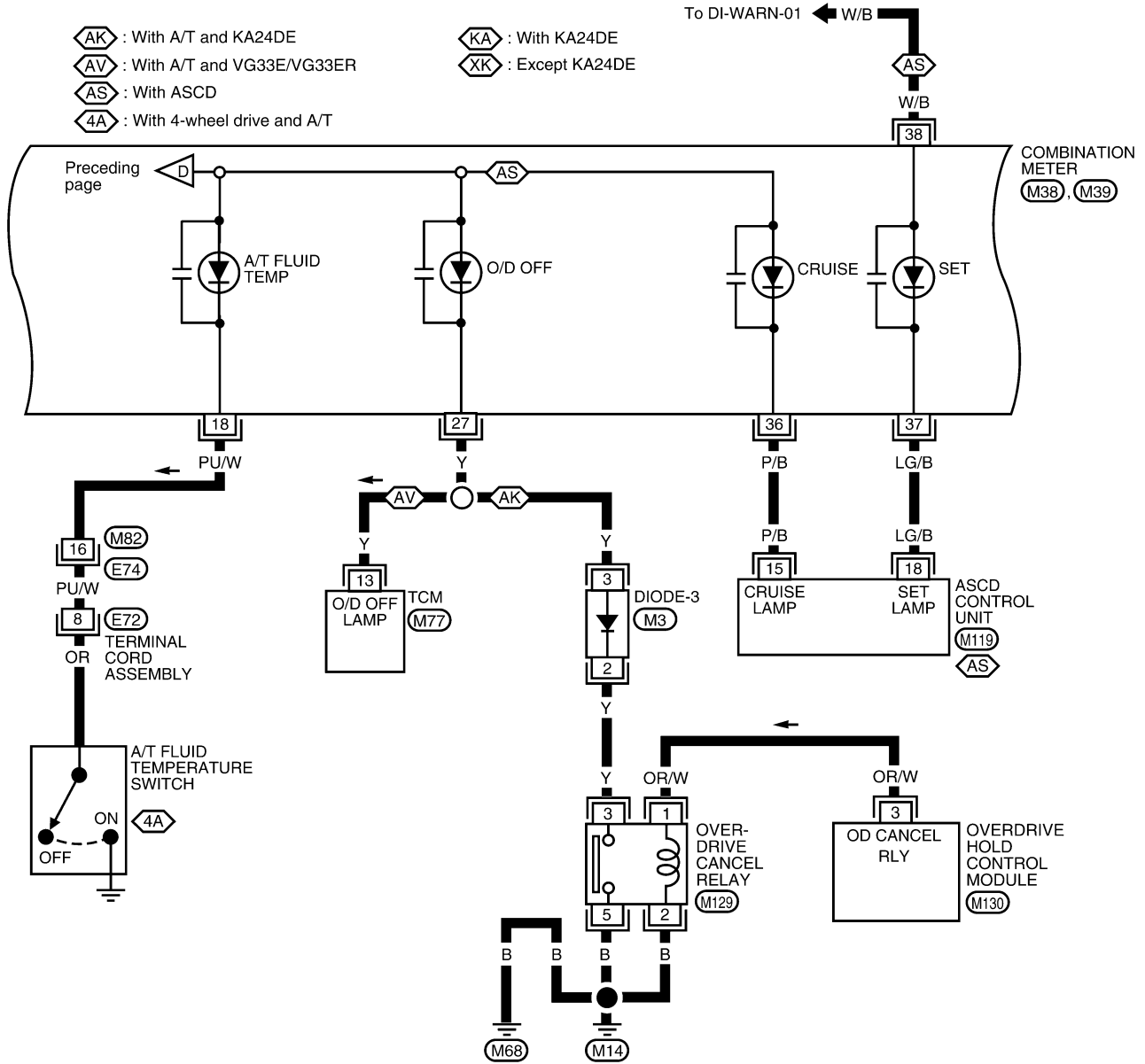

Refer to the following.
(M77) - ELECTRICAL UNITS

WARNING LAMPS

DI-WARN-07

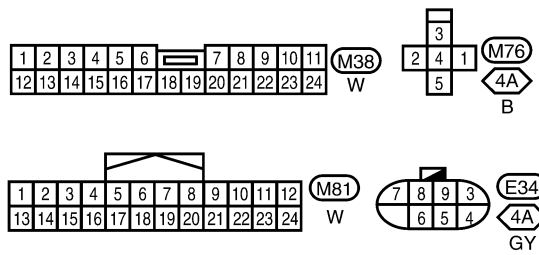
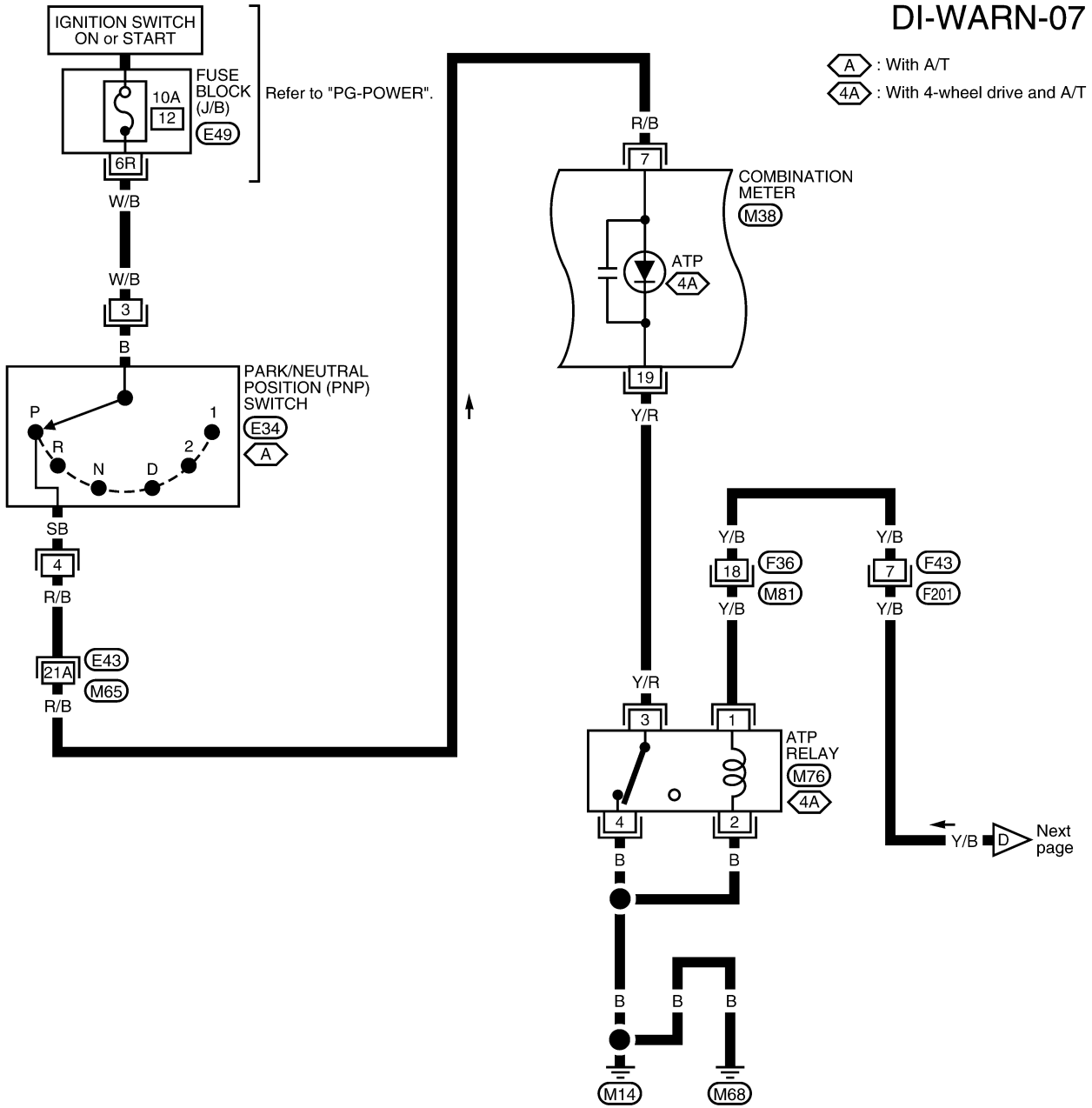

Refer to the following.
 (E43) - SUPER MULTIPLE JUNCTION (SMJ)

WARNING LAMPS

EKS006WH

Electrical Components Inspection FUEL WARNING LAMP SENSOR CHECK

1. Turn ignition switch OFF.
2. Disconnect fuel level sensor unit harness connector C5 (KA models) or C13 (VG models).
3. Connect a resistor (80 Ω) between fuel level sensor unit harness connector C5 (KA models) or C13 (VG models) terminals 1 (KA models) or G (VG models) (OR/B) and 4 (KA models) or E (VG models) (B).
4. Turn ignition switch ON.

The fuel warning lamp should come on.

NOTE:

ECM might store DTC during this inspection. If the DTC is stored in ECM memory, erase the DTC after reconnecting the fuel level sensor unit harness connector. Refer to [EC-61](#) (KA24DE), [EC-632](#) (VG33E), or [EC-1233](#) (VG33ER), "HOW TO ERASE EMISSION-RELATED DIAGNOSTIC INFORMATION".

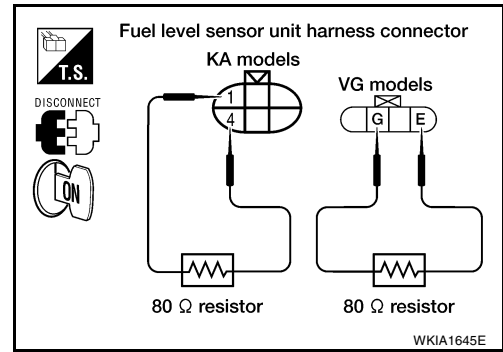

OIL PRESSURE SWITCH CHECK

	Oil pressure kPa (kg/cm ² , psi)	Continuity
Engine start	More than 10 - 20 (0.1 - 0.2, 1 - 3)	No
Engine stop	Less than 10 - 20 (0.1 - 0.2, 1 - 3)	Yes

Check the continuity between oil pressure switch terminal 1 and body ground.

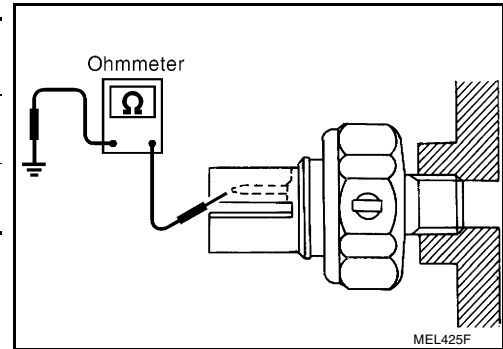

DIODE CHECK

- Check continuity using an ohmmeter.
- Diode is functioning properly if test results are as shown.

NOTE:

Specification may vary depending on the type of tester. Before performing this inspection, be sure to refer to the instruction manual of the tester to be used.

- Check diodes at the combination meter harness connector instead of the combination meter assembly. Refer to [DI-26](#), "Wiring Diagram — WARN —".

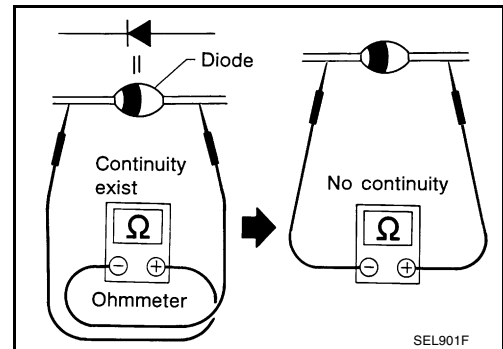

WARNING CHIME

WARNING CHIME

Component Parts and Harness Connector Location

PF24814

EKS006WI

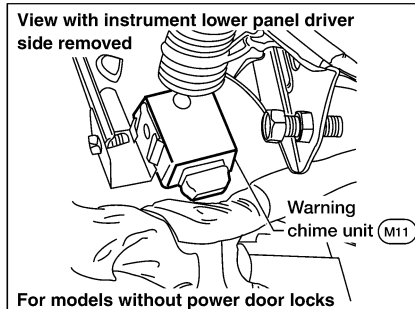
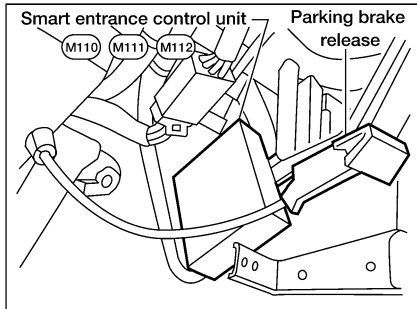
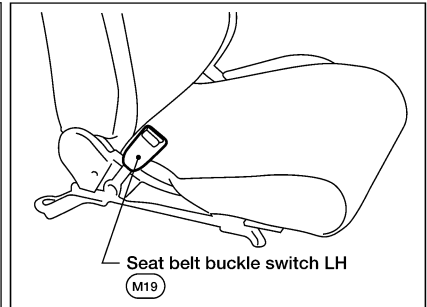
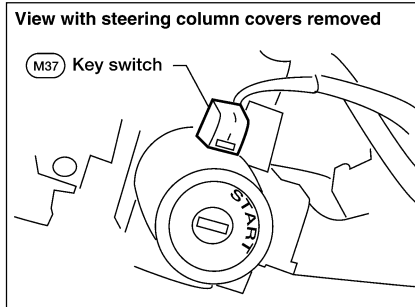
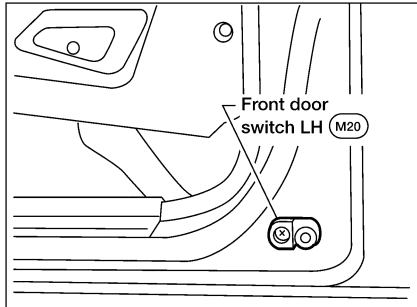
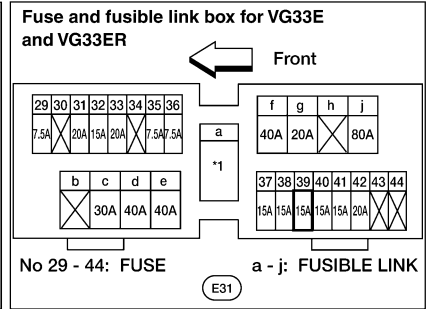
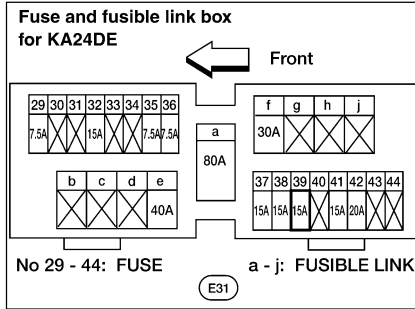
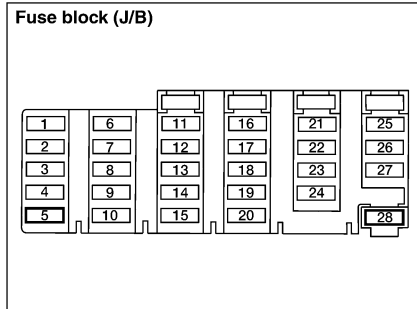

XH : Without heavy duty electrical system

HD : With heavy duty electrical system

*1 XH : 100A

HD : 120A

A
B
C
D
E
F
G
H
I
J
DI
L
M

WARNING CHIME

EKS006WJ

System Description

MODELS WITHOUT POWER DOOR LOCKS

The warning chime is integral to the warning chime unit, which controls its operation. Power is supplied at all times

- through 7.5A fuse [No. 28, located in the fuse block (J/B)]
- to key switch terminal 1.

Power is supplied at all times

- through 15A fuse (No. 39, located in the fuse and fusible link box)
- to lighting switch terminal 11.

With the ignition switch in the ON or START position, power is supplied

- through 10A fuse [No. 5, located in the fuse block (J/B)]
- to warning chime unit terminal 1.

Ground is supplied to warning chime unit terminal 8 through body grounds M14 and M68.

When a signal, or combination of signals, is received by the warning chime unit, the warning chime will sound.

Ignition Key Warning Chime

With the key switch in the INSERTED (key is in the ignition key cylinder) position, the ignition switch in the OFF or ACC position and the front door LH open, the warning chime will sound. A battery positive voltage is supplied

- from key switch terminal 2
- to warning chime unit terminal 5.

Ground is supplied

- to warning chime unit terminal 7
- through front door switch LH terminal 2.

Front door switch LH terminal 3 is grounded through body grounds M14 and M68.

Light Warning Chime

With the front door LH open and lighting switch in the parking and tail lamps ON (1ST) or headlamps ON (2ND) position, the warning chime will sound. A battery positive voltage is supplied

- from lighting switch terminal 12
- to warning chime unit terminal 4.

Ground is supplied

- to warning chime unit terminal 7
- through front door switch LH terminal 2.

Front door switch LH terminal 3 is grounded through body grounds M14 and M68.

Seat Belt Warning Chime

The warning chime will sound for approximately 6 seconds when the ignition switch is turned from OFF to ON with the driver seat belt unfastened (seat belt buckle switch ON).

Ground is supplied

- to warning chime unit terminal 2
- through seat belt buckle switch LH terminal 1.

Seat belt buckle switch LH terminal 2 is grounded through body grounds M14 and M68.

MODELS WITH POWER DOOR LOCKS

The warning chime is controlled by the smart entrance control unit.

Power is supplied at all times

- through 7.5A fuse [No. 28, located in the fuse block (J/B)]
- to key switch terminal 1 and
- to smart entrance control unit terminal 49.

Power is supplied at all times

- through 15A fuse (No. 39, located in the fuse and fusible link box)
- to lighting switch terminal 11.

WARNING CHIME

With the ignition switch in the ON or START position, power is supplied

- through 10A fuse [No. 5, located in the fuse block (J/B)]
- to smart entrance control unit terminal 27.

Ground is supplied to smart entrance control unit terminals 43 and 64 through body grounds M14 and M68. When a signal, or combination of signals, is received by the smart entrance control unit, the warning chime will sound.

Ignition Key Warning Chime

With the key switch in the INSERTED (key is in the ignition key cylinder) position, the ignition switch in the OFF or ACC position and the front door LH open, the warning chime will sound. Power is supplied

- from key switch terminal 2
- to smart entrance control unit terminal 25.

Ground is supplied

- to smart entrance control unit terminal 1
- through front door switch LH terminal 2.

Front door switch LH terminal 3 is grounded through body grounds M14 and M68.

Light Warning Chime

With the front door LH open and lighting switch in parking and tail lamps ON (1ST) or headlamps ON (2ND) position, the warning chime will sound. Power is supplied

- from lighting switch terminal 12
- to smart entrance control unit terminal 58.

Ground is supplied

- to smart entrance control unit terminal 1
- through front door switch LH terminal 2.

Front door switch LH terminal 3 is grounded through body grounds M14 and M68.

Seat Belt Warning Chime

The warning chime will sound for approximately 6 seconds when the ignition switch is turned from OFF to ON with the driver seat belt unfastened (seat belt buckle switch ON).

Ground is supplied

- to smart entrance control unit terminal 28
- through seat belt buckle switch LH terminal 1.

Seat belt buckle switch LH terminal 2 is grounded through body grounds M14 and M68.

A

B

C

D

E

F

G

H

I

J

DI

L

M

WARNING CHIME

EKS006WK

Wiring Diagram — CHIME — MODELS WITHOUT POWER DOOR LOCKS

DI-CHIME-01

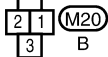
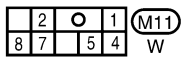
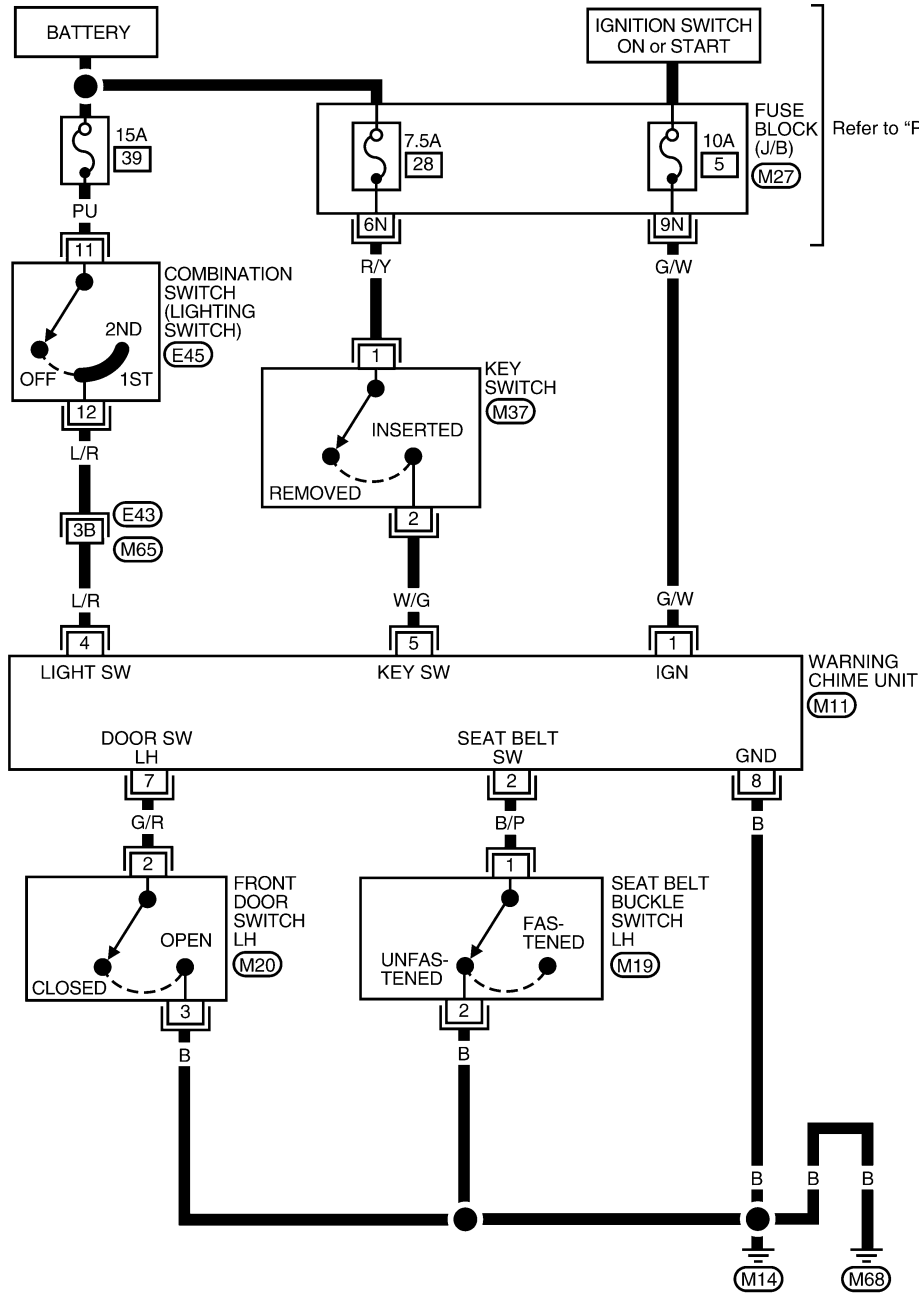

Refer to the following.
E43 - SUPER MULTIPLE JUNCTION (SMJ)

LKWA0114E

WARNING CHIME

MODELS WITH POWER DOOR LOCKS

DI-CHIME-02

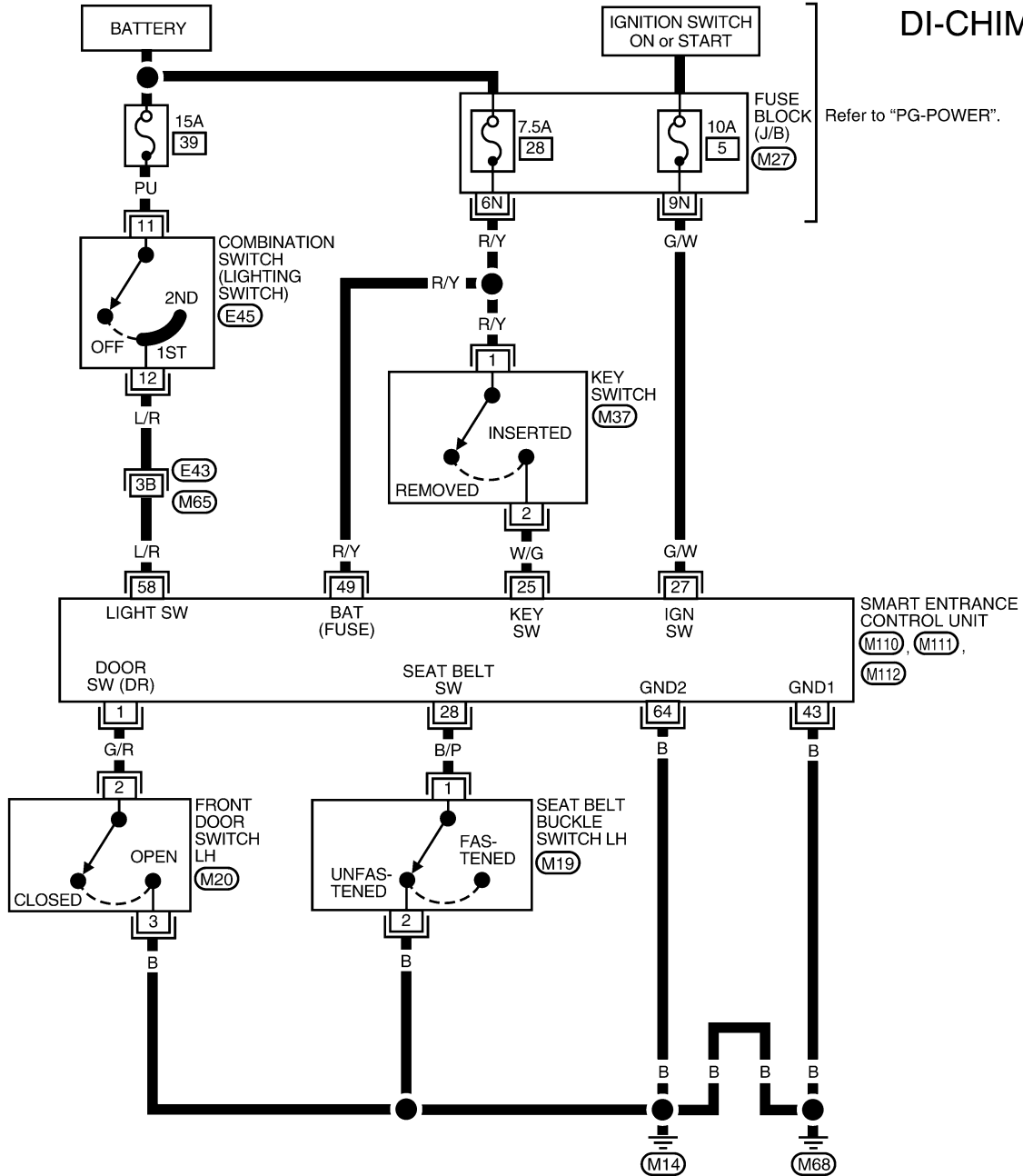

A
B
C
D
E
F
G
H
I
J
DI
L
M

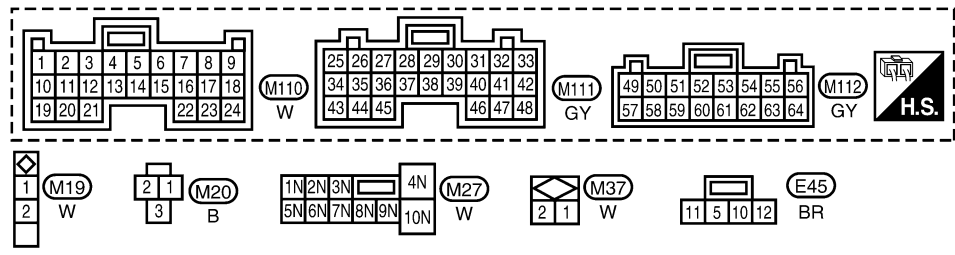

Refer to the following.
 (E43) - SUPER MULTIPLE JUNCTION (SMJ)

WARNING CHIME

Trouble Diagnoses SYMPTOM CHART

EKS006WL

REFERENCE PAGE (DI-)	Without power door locks	DI-41	DI-42	DI-42	DI-44	DI-45
	With power door locks	DI-41	DI-42	DI-43	DI-44	DI-46
SYMPTOM		POWER SUPPLY AND GROUND CIRCUIT CHECK	LIGHTING SWITCH INPUT SIGNAL CHECK	KEY SWITCH (INSERTED) CHECK	SEAT BELT BUCKLE SWITCH LH CHECK	FRONT DOOR SWITCH LH CHECK
Light warning chime does not activate.		X	X			X
Ignition key warning chime does not activate.		X		X		X
Seat belt warning chime does not activate.		X			X	
All warning chimes do not activate.		X				

X: Applicable

WARNING CHIME

POWER SUPPLY AND GROUND CIRCUIT CHECK

Main Power Supply Circuit Check

● Models without power door locks

Terminals		Ignition switch position		
(+)	(-)	OFF	ACC	ON
1	Ground	0V	0V	Battery voltage

If NG, check the following.

- 10A fuse [No. 5, located in the fuse block (J/B)]
- Harness for open or short between warning chime unit and fuse

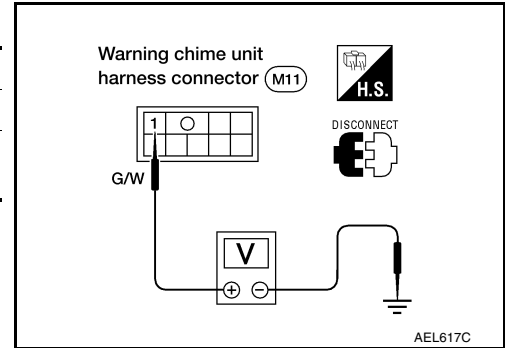

● Models with power door locks

Terminals		Ignition switch position			
(+) Connector		(-)	OFF	ACC	ON
M111	27 (G/W)	Ground	0V	0V	Battery voltage
M112	49 (R/Y)	Ground	Battery voltage	Battery voltage	Battery voltage

If NG, check the following.

- 7.5A fuse [No. 28, located in the fuse block (J/B)]
- 10A fuse [No. 5, located in the fuse block (J/B)]
- Harness for open or short between smart entrance control unit and fuse(s)

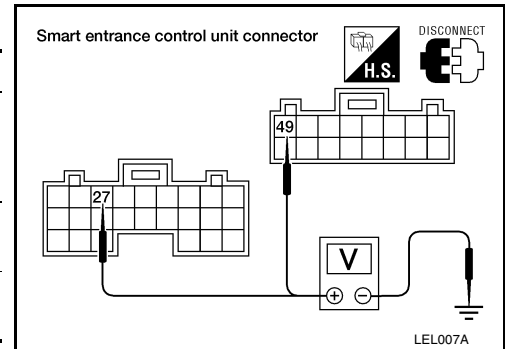

Ground Circuit Check

● Models without power door locks

Terminals	Continuity
8 - Ground	Yes

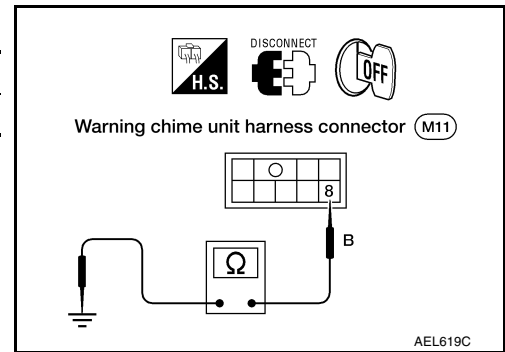

● Models with power door locks

Terminals	Continuity
M111 - 43 (B) - Ground	Yes
M112 - 64 (B) - Ground	Yes

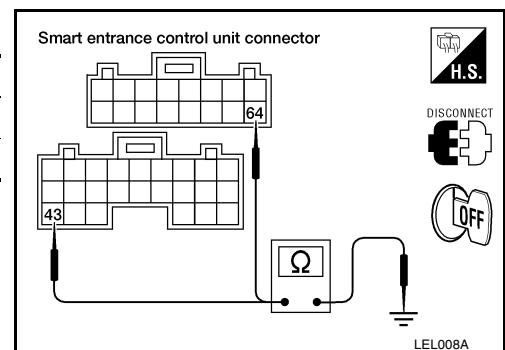

A
B
C
D
E
F
G
H
I
J
L
M

DI

WARNING CHIME

LIGHTING SWITCH INPUT SIGNAL CHECK

Models without Power Door Locks

1. CHECK LIGHTING SWITCH INPUT SIGNAL

Check voltage between warning chime unit terminal 4 and ground.

Voltage (V) (Approx.):

Lighting switch position: 1ST or 2ND : 12V

Lighting switch position: OFF : 0V

OK or NG

OK >> Lighting switch is OK.

NG >> Check the following.

- 15A fuse (No. 39, located in the fuse and fusible link box)
- Harness for open or short between warning chime unit and lighting switch

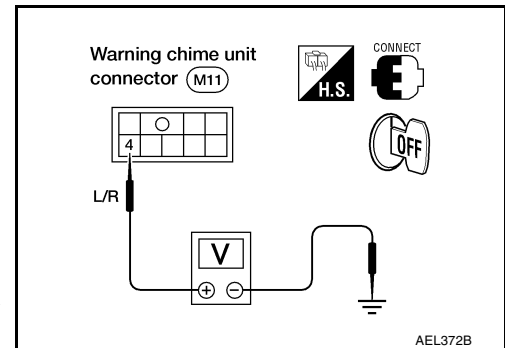

Models with Power Door Locks

1. CHECK LIGHTING SWITCH INPUT SIGNAL

Check voltage between smart entrance control unit connector M112 terminal 58 (L/R) and ground.

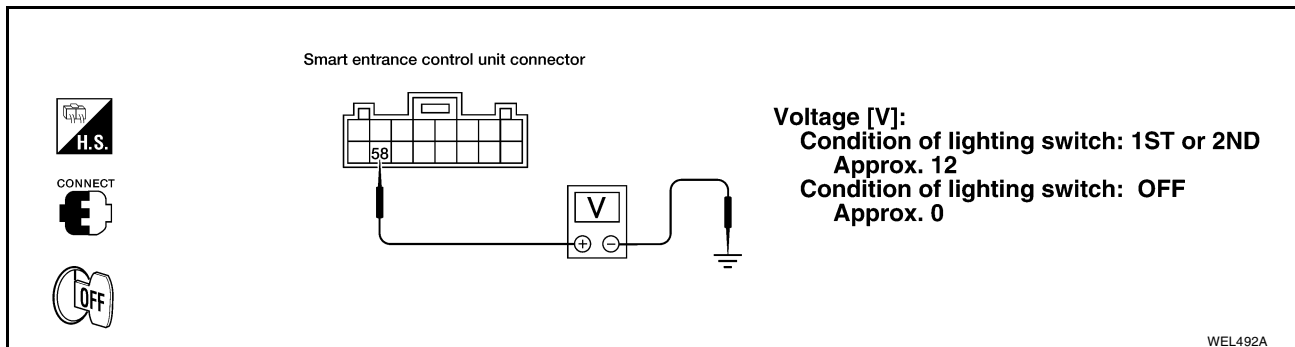

OK or NG

OK >> Lighting switch is OK.

NG >> Check the following.

- 15A fuse (No. 39, located in the fuse and fusible link box)
- Harness for open or short between smart entrance control unit and lighting switch

KEY SWITCH (INSERTED) CHECK

Models without Power Door Locks

1. CHECK KEY SWITCH INPUT SIGNAL

Check voltage between warning chime unit terminal 5 and ground.

Voltage [V] (Approx.):

Key is INSERTED : 12V

Key is REMOVED : 0V

OK or NG

OK >> Key switch is OK.

NG >> GO TO 2.

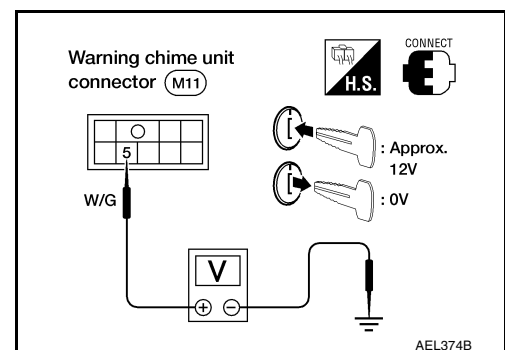

WARNING CHIME

2. CHECK KEY SWITCH (INSERTED)

Check continuity between terminals 1 and 2.

Continuity:

Key is INSERTED : Yes

Key is REMOVED : No

OK or NG

OK >> Check the following.

- 7.5A fuse [No. 28, located in fuse block (J/B)]
- Harness for open or short between key switch and fuse
- Harness for open or short between warning chime unit and key switch

NG >> Replace key switch.

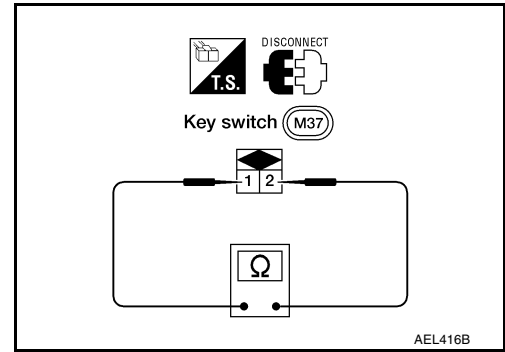

Models with Power Door Locks

1. CHECK KEY SWITCH INPUT SIGNAL

Check voltage between smart entrance control unit connector M111 terminal 25 (W/G) and ground.

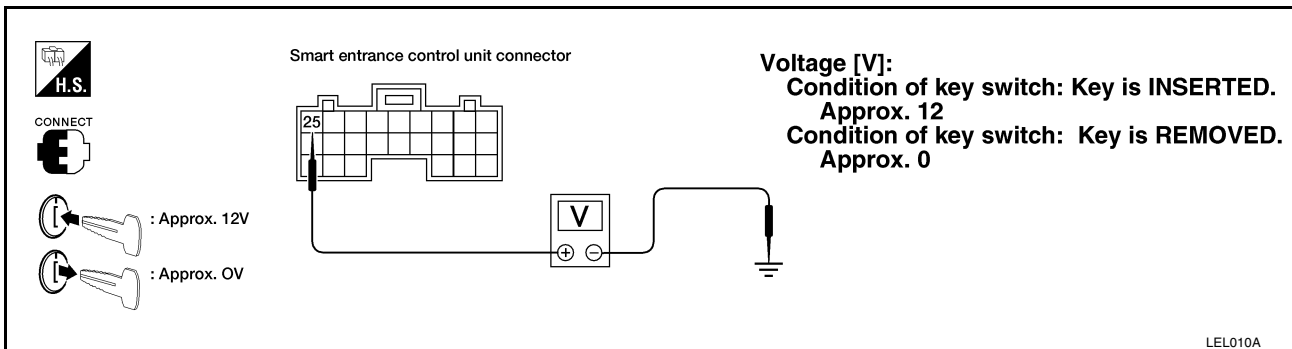

OK or NG

OK >> Key switch is OK.

NG >> GO TO 2.

2. CHECK KEY SWITCH (INSERTED)

Check continuity between terminals 1 and 2.

Continuity:

Key is INSERTED : Yes

Key is REMOVED : No

OK or NG

OK >> Check the following.

- 7.5A fuse [No. 28, located in fuse block (J/B)]
- Harness for open or short between key switch and fuse
- Harness for open or short between smart entrance control unit and key switch

NG >> Replace key switch.

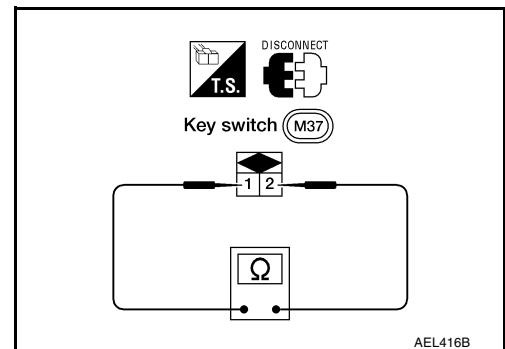

WARNING CHIME

SEAT BELT BUCKLE SWITCH LH CHECK

Models without Power Door Locks

1. CHECK SEAT BELT BUCKLE SWITCH LH INPUT SIGNAL

1. Turn ignition switch ON.
2. Check voltage between warning chime unit terminal 2 and ground.

Voltage (V) (Approx.):

Seat belt is FASTENED. : 12V

Seat belt is UNFASTENED. : 0V

OK or NG

OK >> Seat belt buckle switch LH is OK.

NG >> GO TO 2.

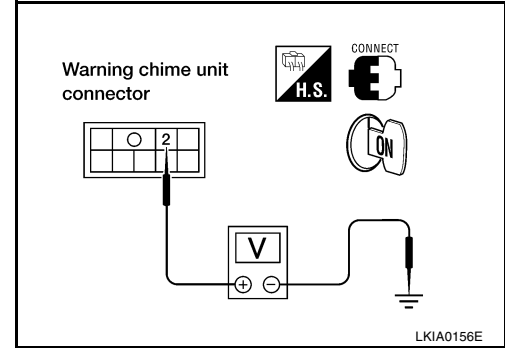

2. CHECK SEAT BELT BUCKLE SWITCH LH

Check continuity between terminals 1 and 2 when seat belt is fastened and unfastened.

Continuity:

Seat belt is FASTENED. : No

Seat belt is UNFASTENED. : Yes

OK or NG

OK >> Check the following.

- Seat belt buckle switch LH ground circuit
- Harness for open or short between warning chime unit and seat belt buckle switch LH

NG >> Replace seat belt buckle switch LH.

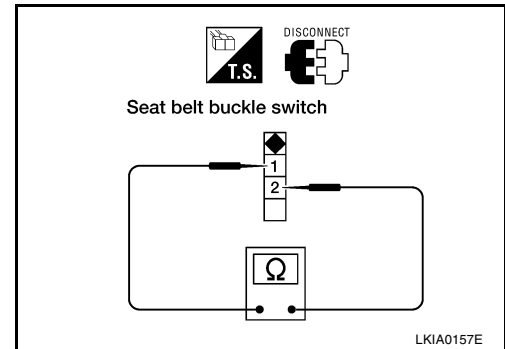

Models with Power Door Locks

1. CHECK SEAT BELT BUCKLE SWITCH LH INPUT SIGNAL

1. Turn ignition switch ON.
2. Check voltage between smart entrance control unit connector M111 terminal 28 (B/P) and ground.

Voltage (V) (Approx.):

Seat belt is FASTENED. : 12V

Seat belt is UNFASTENED. : 0V

OK or NG

OK >> Seat belt buckle switch LH is OK.

NG >> GO TO 2.

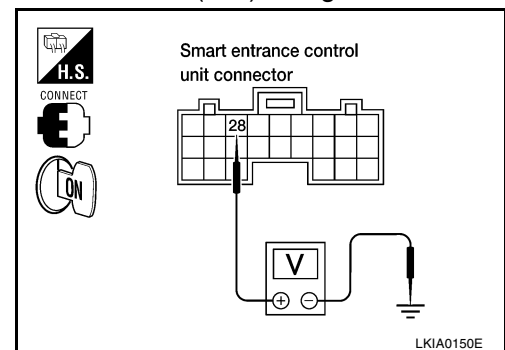

WARNING CHIME

2. CHECK SEAT BELT BUCKLE SWITCH LH

Check continuity between terminals 1 and 2 when seat belt is fastened and unfastened.

Continuity:

- Seat belt is FASTENED. : No**
- Seat belt is UNFASTENED. : Yes**

OK or NG

OK >> Check the following.

- Seat belt buckle switch LH ground circuit
- Harness for open or short between smart entrance control unit and seat belt buckle switch LH

NG >> Replace seat belt buckle switch LH.

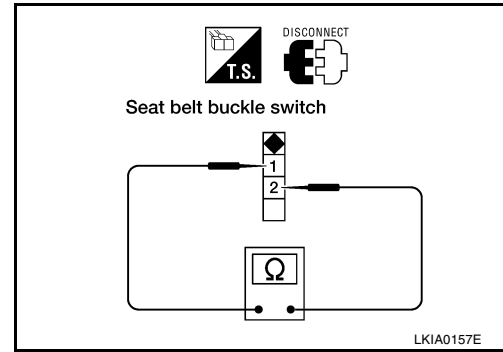

FRONT DOOR SWITCH LH CHECK

Models without Power Door Locks

1. CHECK FRONT DOOR SWITCH LH INPUT SIGNAL

Check voltage between warning chime unit terminal 7 and ground.

Voltage (V) (Approx.):

- Front door LH is CLOSED. : 12V**
- Front door LH is OPEN. : 0V**

OK or NG

OK >> Front door switch LH is OK.

NG >> GO TO 2.

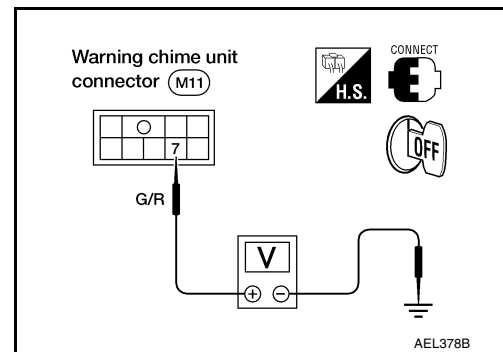

2. CHECK FRONT DOOR SWITCH LH

Check continuity between front door switch LH terminals 2 and 3.

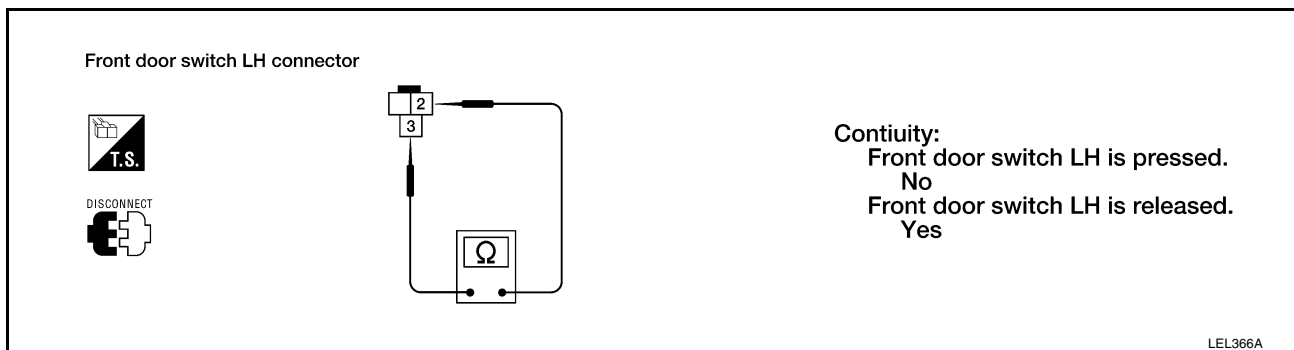

OK or NG

OK >> Check the following.

- Front door switch LH ground circuit
- Harness for open or short between warning chime unit and front door switch LH

NG >> Replace front door switch LH.

WARNING CHIME

Models with Power Door Locks

1. CHECK FRONT DOOR SWITCH LH INPUT SIGNAL

Check voltage between smart entrance control unit connector M110 terminal 1 (G/R) and ground.

Voltage (V) (Approx.):

Front door LH is CLOSED. : 12V

Front door LH is OPEN. : 0V

OK or NG

OK >> Front door switch LH is OK.

NG >> GO TO 2.

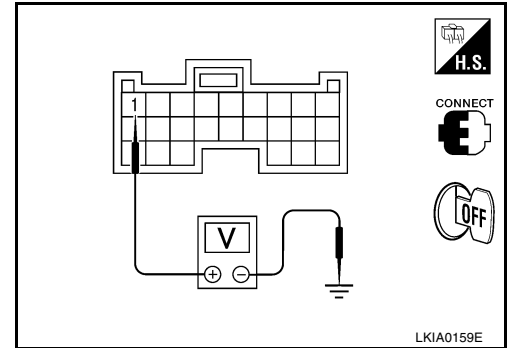

2. CHECK FRONT DOOR SWITCH LH

Check continuity between front door switch LH connector M20 terminals 2 and 3.

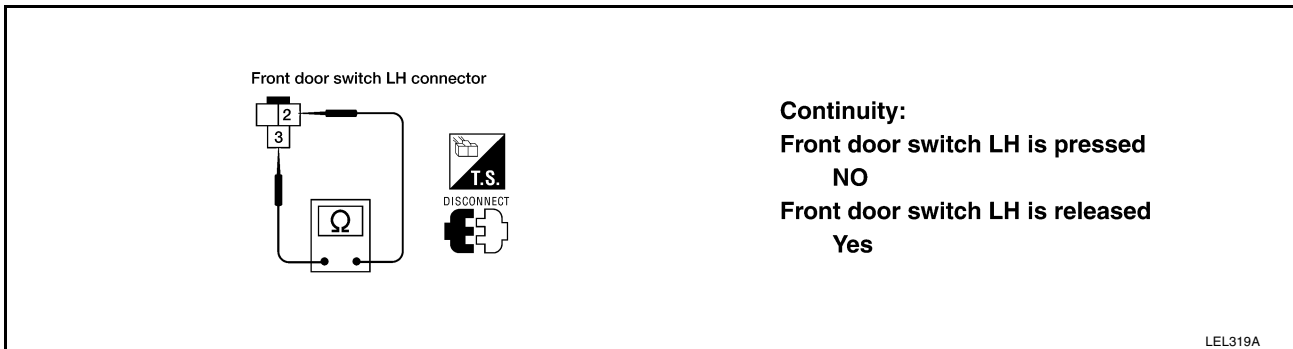

OK or NG

OK >> Check the following.

- Front door switch LH ground circuit
- Harness for open or short between smart entrance control unit and front door switch LH

NG >> Replace front door switch LH.