

SECTION **ACC**  
ACCELERATOR CONTROL SYSTEM

A  
ACC  
C  
D  
E  
F  
G  
H  
I  
J  
K  
L  
M

CONTENTS

<b>ACCELERATOR CONTROL SYSTEM</b> .....	<b>2</b>	Removal and Installation .....	<b>2</b>
		Adjusting Accelerator Wire .....	<b>2</b>

# ACCELERATOR CONTROL SYSTEM

## ACCELERATOR CONTROL SYSTEM

PFP:18005

### Removal and Installation

EBS00HZM

#### Accelerator Pedal and Wire

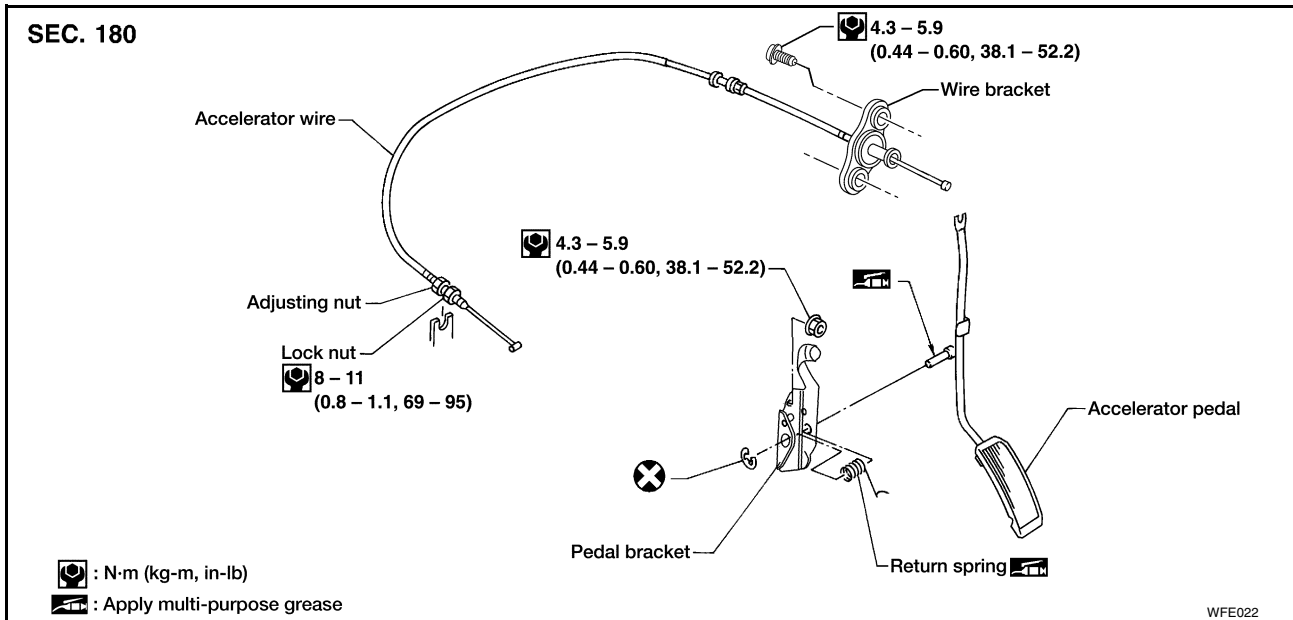

#### CAUTION:

- The accelerator wire should be adjusted when removing or replacing any parts of the Accelerator Control System.
- Check that the throttle valve opens fully when the accelerator pedal is fully depressed. Also check that the throttle valve returns to the idle position when the accelerator pedal is released.
- Check the accelerator control parts for interference contact with any adjacent parts.
- When connecting the accelerator wire, be careful not to twist or scratch the inner wire.
- Refer to [ACS-23, "ASCD Wire Adjustment"](#).

#### Adjusting Accelerator Wire

EBS00HZM

#### NOTE:

Adjust the accelerator wire with the engine warmed up to normal operating temperature and the ignition switch turned to OFF.

1. Remove the vacuum hose connected to the throttle opener.
2. Connect a suitable vacuum hose to the vacuum pump.
3. Apply vacuum [more than -40.00 kPa (-300 mmHg, -11.81 inHg)] until the throttle drum becomes free from the rod of the throttle opener (VG33E only).
  - Make sure that there is clearance between the throttle drum and rod.
    - If there is no clearance, refer to [EC-74, "Basic Inspection"](#) (KA24DE), or [EC-646, "Basic Inspection"](#) (VG33E), or [EC-1247, "Basic Inspection"](#) (VG33ER).
    - If there is clearance, go to the following steps.

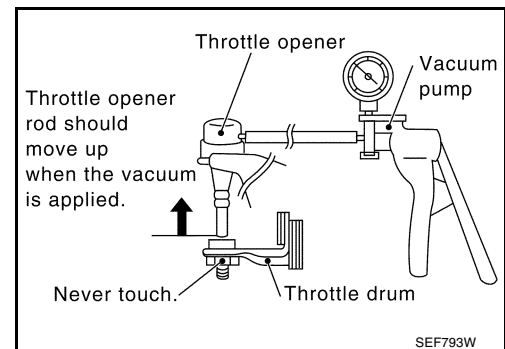

## ACCELERATOR CONTROL SYSTEM

- Loosen the lock nut and tighten the accelerator adjusting nut until the throttle drum starts to move.
- From that position, turn back the adjusting nut 1.5 to 2 turns, and tighten the lock nut to specification as shown.
- Release the vacuum from the throttle opener.
- Remove the vacuum pump hose from the throttle opener.
- Reinstall the original vacuum hose to the throttle opener.

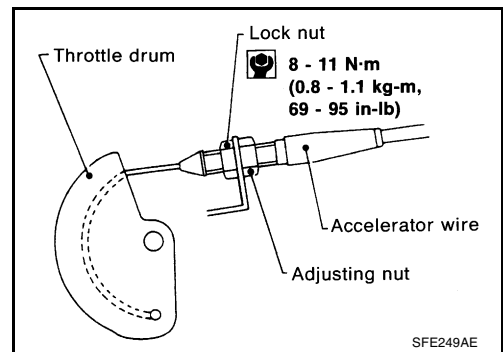

A

ACC

C

D

E

F

G

H

I

J

K

L

M

# ACCELERATOR CONTROL SYSTEM

---