

SECTION MA
MAINTENANCE

A
B
C

CONTENTS

<p>PRECAUTIONS 3 Precautions for Supplemental Restraint System (SRS) "AIR BAG" and "SEAT BELT PRE-TENSIONER" 3</p> <p>PREPARATION 4 Special Service Tools 4 Commercial Service Tool 4</p> <p>GENERAL MAINTENANCE 5 General Maintenance 5</p> <p>PERIODIC MAINTENANCE 7 Periodic Maintenance 7 SCHEDULE 1 7 SCHEDULE 2 10</p> <p>RECOMMENDED FLUIDS AND LUBRICANTS 12 Recommended Fluids and Lubricants 12 FLUIDS AND LUBRICANTS 12 SAE VISCOSITY NUMBER 14 ANTI-FREEZE COOLANT MIXTURE RATIO 14</p> <p>ENGINE MAINTENANCE (KA24DE) 15 Checking Drive Belts 15 DRIVE BELT DEFLECTION AND TENSION 16 Changing Engine Coolant 16 DRAINING ENGINE COOLANT 16 REFILLING ENGINE COOLANT 17 FLUSHING COOLING SYSTEM 18 Checking Fuel Lines 18 Changing Fuel Filter 18 WITH CONSULT - II 18 WITHOUT CONSULT - II 19 Changing Air Cleaner Filter 20 Changing Engine Oil 20 Changing Oil Filter 21 Changing Spark Plugs 22 Checking EVAP Vapor Lines 23 Changing Positive Crankcase Ventilation (PCV) Filter 23</p> <p>ENGINE MAINTENANCE (VG33E AND VG33ER).. 24 Checking Drive Belts 24 DRIVE BELT DEFLECTION AND TENSION 25 Changing Engine Coolant 26</p>	<p>DRAINING ENGINE COOLANT 26 REFILLING ENGINE COOLANT 26 FLUSHING COOLING SYSTEM 28 Checking Fuel Lines 28 Changing Fuel Filter 28 WITH CONSULT - II 28 WITHOUT CONSULT - II 29 Changing Air Cleaner Filter 30 VISCOUS PAPER TYPE 30 Changing Engine Oil 30 Changing Oil Filter 31 Changing Spark Plugs 32 Checking EVAP Vapor Lines 35</p> <p>CHASSIS AND BODY MAINTENANCE 36 Changing In-cabin Microfilter 36 Checking Exhaust System 36 Checking Clutch Fluid Level and Leaks 36 Checking M/T Oil 36 Changing M/T Oil 36 Checking Water Entry—For 4WD Models With M/T.. 37 Checking A/T Fluid 37 Changing A/T Fluid 38 Checking Transfer Fluid 38 Changing Transfer Fluid 38 Checking Propeller Shaft 39 Greasing Propeller Shaft 39 Checking Differential Gear Oil 39 Changing Differential Gear Oil 40 LIMITED-SLIP DIFFERENTIAL GEAR 40 Balancing Wheels 41 Tire Rotation 41 Checking Brake Fluid Level and Leaks 41 Checking Brake Lines and Cables 41 Checking Disc Brake 42 ROTOR 42 CALIPER 42 PAD 42 Checking Drum Brake 42 WHEEL CYLINDER 42 DRUM 42</p>
---	--

D
E

F

G

H

I

J

K

MA

M

LINING	43	FRONT AND REAR AXLE AND SUSPENSION	
Checking Steering Gear and Linkage	43	PARTS	44
STEERING GEAR	43	DRIVE SHAFT	44
STEERING LINKAGE	43	Lubricating Locks, Hinges and Hood Latches	45
Checking Power Steering Fluid and Lines	43	Checking Seat Belts, Buckles, Retractors, Anchors	
CHECKING FLUID LEVEL	43	and Adjusters	46
CHECKING LINES	43	Wheel Balance	47
Checking Axle and Suspension Parts	44		

PRECAUTIONS

PRECAUTIONS

PF0:00001

Precautions for Supplemental Restraint System (SRS) “AIR BAG” and “SEAT BELT PRE-TENSIONER”

ELS000N9

The Supplemental Restraint System such as “AIR BAG” and “SEAT BELT PRE-TENSIONER”, used along with a front seat belt, helps to reduce the risk or severity of injury to the driver and front passenger for certain types of collision. This system may include seat belt switch inputs and dual stage front air bag modules. If equipped with dual stage front air bag modules, the SRS system uses the seat belt switches to determine the front air bag deployment, and may only deploy one front air bag, depending on the severity of a collision and whether the front occupants are belted or unbelted. Information necessary to service the system safely is included in the SRS and SB section of this Service Manual.

The vehicle may be equipped with a passenger air bag deactivation switch. Because no rear seat exists where a rear-facing child restraint can be placed, the switch is designed to turn off the passenger air bag so that a rear-facing child restraint can be used in the front passenger seat. The switch is located in the center of the instrument panel, near the ashtray. When the switch is turned to the ON position, the passenger air bag is enabled and could inflate for certain types of collision. When the switch is turned to the OFF position, the passenger air bag is disabled and will not inflate. A passenger air bag OFF indicator on the instrument panel lights up when the passenger air bag is switched OFF. The driver air bag always remains enabled and is not affected by the passenger air bag deactivation switch.

WARNING:

- To avoid rendering the SRS inoperative, which could increase the risk of personal injury or death in the event of a collision which would result in air bag inflation, all maintenance must be performed by an authorized NISSAN/INFINITI dealer.
- Improper maintenance, including incorrect removal and installation of the SRS, can lead to personal injury caused by unintentional activation of the system. For removal of Spiral Cable and Air Bag Module, see the SRS section.
- Do not use electrical test equipment on any circuit related to the SRS unless instructed to in this Service Manual. SRS wiring harnesses can be identified by yellow and/or orange harness connectors.
- The vehicle may be equipped with a passenger air bag deactivation switch which can be operated by the customer. When the passenger air bag is switched OFF, the passenger air bag is disabled and will not inflate. When the passenger air bag is switched ON, the passenger air bag is enabled and could inflate for certain types of collision. After SRS maintenance or repair, make sure the passenger air bag deactivation switch is in the same position (ON or OFF) as when the vehicle arrived for service.

A
B
C
D
E
F
G
H
I
J
K
MA
M

PREPARATION

PREPARATION

PFP:00002

Special Service Tools

ELS000DB

The actual shapes of Kent-Moore tools may differ from those of special service tools illustrated here.

Tool number (Kent-Moore No.) Tool name	Description
KV10115801 (J-38956) Oil filter cap wrench	Removing and installing oil filter a: 64.3 mm (2.531 in)

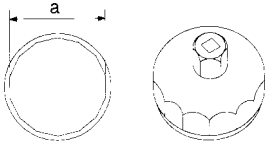

NT375

Commercial Service Tool

ELS000DC

Tool name (Kent-Moore No.)	Description
Belt tension gauge (BT-3373-F)	Checking drive belt tension
Coolant refill tool (J-45695)	Filling cooling system

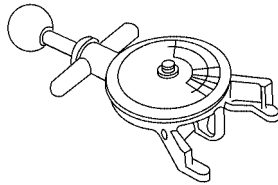

AMA126

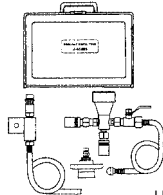

LMA053

GENERAL MAINTENANCE

GENERAL MAINTENANCE

PFP:00000

General Maintenance

ELS000EQ

General maintenance includes those items which should be checked during the normal day-to-day operation of the vehicle. They are essential if the vehicle is to continue operating properly. The owners can perform checks and inspections themselves or have their NISSAN dealers do them.

OUTSIDE THE VEHICLE

The maintenance items listed here should be performed from time to time, unless otherwise specified.

Item		Reference page
Tires	Check the pressure with a gauge at least once a month and always prior to a long distance trip. Adjust to the specified pressure if necessary. Check carefully for damage, cuts or excessive wear.	—
Wheel nuts	When checking the tires, make sure no nuts are missing, and check for any loose nuts. Tighten if necessary.	MA-41, "Tire Rotation"
Windshield	Clean the windshield on a regular basis. Check the windshield at least every six months for cracks or other damage. Repair as necessary.	
Tire rotation	Tires should be rotated every 12,000 km (7,500 miles).	MA-41, "Tire Rotation"
Wheel alignment and balance	If the vehicle pulls to either side while driving on a straight and level road, or if you detect uneven or abnormal tire wear, there may be a need for wheel alignment. If the steering wheel or seat vibrates at normal highway speeds, wheel balancing may be needed.	MA-41, "Balancing Wheels" , FSU-10, "Front Wheel Alignment"
Windshield wiper blades	Check for cracks or wear if they do not wipe properly.	—
Doors and engine hood	Check that all doors and the engine hood operate smoothly as well as the trunk lid and back hatch. Also make sure that all latches lock securely. Lubricate if necessary. Make sure that the secondary latch keeps the hood from opening when the primary latch is released. When driving in areas using road salt or other corrosive materials, check lubrication frequently.	MA-45, "Lubricating Locks, Hinges and Hood Latches"
Lamps	Make sure that the headlamps, stop lamps, tail lamps, turn signal lamps, and other lamps are all operating properly and installed securely. Also check headlamp aim. Clean the headlamps on a regular basis.	LT-9, "Aiming Adjustment" for US, LT-17, "Aiming Adjustment" for Canada

INSIDE THE VEHICLE

The maintenance items listed here should be checked on a regular basis, such as when performing periodic maintenance, cleaning the vehicle, etc.

Item		Reference page
Warning lamps and buzzers/chimes	Make sure that all warning lamps and buzzers/chimes are operating properly.	LT-29, "Trouble Diagnoses"
Windshield wiper and washer	Check that the wipers and washer operate properly and that the wipers do not streak.	—
Windshield defroster	Check that the air comes out of the defroster outlets properly and in sufficient quantity when operating the heater or air conditioner.	—
Steering wheel	Check that it has the specified play. Be sure to check for changes in the steering condition, such as excessive play, hard steering or strange noises.	PS-6, "Checking Steering Wheel Play"
Seats	Check seat position controls such as seat adjusters, seatback recliner, etc. to make sure they operate smoothly and that all latches lock securely in every position. Check that the head restraints move up and down smoothly and that the locks (if equipped) hold securely in all latched positions. Check that the latches lock securely for folding-down rear seatbacks.	—
Seat belts	Check that all parts of the seat belt system (e.g. buckles, anchors, adjusters and retractors) operate properly and smoothly and are installed securely. Check the belt webbing for cuts, fraying, wear or damage.	MA-46, "Checking Seat Belts, Buckles, Retractors, Anchors and Adjusters" , SB-8, "Seat Belt Inspection"
Accelerator pedal	Check that pedal for smooth operation and make sure the pedal does not catch or require uneven effort. Keep the floor mats away from the pedal.	ACC-2, "Adjusting Accelerator Wire"

GENERAL MAINTENANCE

Item		Reference page
Clutch pedal	Make sure the pedal operates smoothly and check that it has the proper free play.	CL-6, "CLUTCH PEDAL INSPECTION AND ADJUSTMENT"
Brakes	Check that the brake does not pull the vehicle to one side when applied.	—
Brake pedal and booster	Check the pedal for smooth operation and make sure it has the proper distance under it when depressed fully. Check the brake booster function. Be sure to keep floor mats away from the pedal.	BR-7, "Inspection" , BR-19, "On-vehicle Service"
Parking brake	Check that the lever has the proper travel and make sure that the vehicle is held securely on a fairly steep hill when only the parking brake is applied.	PB-2, "PARKING BRAKE CONTROL"
Automatic transmission "Park" mechanism	Check that the lock release button on the selector lever operates properly and smoothly. On a fairly steep hill check that the vehicle is held securely with the selector lever in the P position without applying any brakes.	—

UNDER THE HOOD AND VEHICLE

The maintenance items listed here should be checked periodically (e.g. each time you check the engine oil or refuel).

Item		Reference page	
		KA24DE	VG33E and VG33ER
Windshield washer fluid	Check that there is adequate fluid in the tank.	—	
Engine coolant level	Check the coolant level when the engine is cold.	CO-8	CO-23
Radiator and hoses	Check the front of the radiator and clean off any dirt, insects, leaves, etc., that may have accumulated. Make sure the hoses have no cracks, deformation, deterioration or loose connections.	—	
Brake and clutch fluid levels	Make sure that the brake and clutch fluid levels are between the "MAX" and "MIN" lines on the reservoirs	MA-41, MA-36	
Battery	Check the fluid level in each cell. It should be between the "MAX" and "MIN" lines. Vehicles operated in high temperatures or under severe conditions require frequent checks of the battery fluid level.	—	
Engine drive belts	Make sure that no belt is frayed, worn, cracked or oily.	MA-15	MA-24
Engine oil level	Check the level on the dipstick after parking the vehicle on a level spot and turning off the engine.	MA-20	MA-30
Power steering fluid level and lines	Check the level on the reservoir with the engine off. Check the lines for improper attachment, leaks, cracks, etc.	MA-43	
Automatic transmission fluid level	Check the level on the dipstick after putting the selector lever in "P" with the engine idling.	MA-37	
Exhaust system	Make sure there are no loose supports, cracks or holes. If the sound of the exhaust seems unusual or there is a smell of exhaust fumes, immediately locate the trouble and correct it.	MA-36	
Underbody	The underbody is frequently exposed to corrosive substances such as those used on icy roads or to control dust. It is very important to remove these substances, otherwise rust will form on the floor pan, frame, fuel lines and around the exhaust system. At the end of winter, the underbody should be thoroughly flushed with plain water, being careful to clean those areas where mud and dirt can easily accumulate.	—	
Fluid leaks	Check under the vehicle for fuel, oil, water or other fluid leaks after the vehicle has been parked for a while. Water dripping from the air conditioner after use is normal. If you should notice any leaks or gasoline fumes are evident, check for the cause and correct it immediately.	—	

PERIODIC MAINTENANCE

PERIODIC MAINTENANCE

PFP:00026

Periodic Maintenance

ELS000ER

Two different maintenance schedules are provided, and should be used, depending upon the conditions in which the vehicle is mainly operated. **After 60,000 miles (96,000 km) or 48 months, continue the periodic maintenance at the same mileage/time intervals.**

Schedule 1	Follow Periodic Maintenance Schedule 1 if your driving habits frequently includes one or more of the following driving conditions: <ul style="list-style-type: none"> ● Repeated short trips of less than 5 miles (8 km). ● Repeated short trips of less than 10 miles (16 km) with outside temperatures remaining below freezing. ● Operating in hot weather in stop-and-go "rush hour" traffic. ● Extensive idling and/or low speed driving for long distances, such as police, taxi or door-to-door delivery use. ● Driving in dusty conditions. ● Driving on rough, muddy, or salt spread roads. ● Towing a trailer, using a camper or a car-top carrier. 	Emission Control System Maintenance	MA-7
		Chassis and Body Maintenance	MA-9
Schedule 2	Follow Periodic Maintenance Schedule 2 if none of the driving conditions shown in Schedule 1 apply to the driving habits.	Emission Control System Maintenance	MA-10
		Chassis and Body Maintenance	MA-11

Maintenance for off-road driving (4x4 only)

Whenever you drive off-road through sand, mud or water, more frequent maintenance may be required of the following items:

- ▲ Brake pads and rotors
- ▲ Brake lining and drums
- ▲ Brake lines and hoses
- ▲ Wheel bearing grease and free-running hub grease
- ▲ Differential, transmission and transfer oil
- ▲ Steering linkage
- ▲ Propeller shaft and drive shafts
- ▲ Air cleaner filter
- ▲ Clutch housing. Refer to [MA-37, "Checking Water Entry — For 4WD Models With M/T"](#).

SCHEDULE 1

Emission Control System Maintenance

Abbreviations: R = Replace. I = Inspect. Correct or replace if necessary. []: At the mileage intervals only

MAINTENANCE OPERATION		MAINTENANCE INTERVAL								Reference Section - Page or - Content Title		
		Miles x 1,000 (km x 1,000) Months	3.75 (6) 3	7.5 (12) 6	11.25 (18) 9	15 (24) 12	18.75 (30) 15	22.5 (36) 18	26.25 (42) 21			30 (48) 24
Perform at number of miles, kilometers or months, whichever comes first.											KA24DE	VG33E and VG33ER
Drive belts										I*	MA-15	MA-24
Air cleaner filter	NOTE (1)									[R]	MA-20	MA-30
Positive crankcase ventilation (PCV) filter	NOTE (2)									[R]	MA-23	—
EVAP vapor lines										I*	MA-23	MA-35
Fuel lines										I*	MA-18	MA-28
Fuel filter*	NOTE (2)										MA-18	MA-28
Engine coolant	NOTE (3)										MA-16	MA-26
Engine oil			R	R	R	R	R	R	R	R	MA-20	MA-30

PERIODIC MAINTENANCE

MAINTENANCE OPERATION		MAINTENANCE INTERVAL								Reference Section - Page or - Content Title	
Perform at number of miles, kilometers or months, whichever comes first.	Miles x 1,000	3.75 (6)	7.5 (12)	11.25 (18)	15 (24)	18.75 (30)	22.5 (36)	26.25 (42)	30 (48)	KA24DE	VG33E and VG33ER
	(km x 1,000)										
	Months										
Engine oil filter (Use part No. 15208 31U00, 15208 9E000, 15208 7B000 or equivalent for VG engine.)		R	R	R	R	R	R	R	R	MA-21	MA-31
Spark plugs (Double PLATINUM-TIPPED type)		Replace every 105,000 miles (169,000 km)								MA-22	MA-32
Timing belt		Replace every 105,000 miles (169,000 km)								—	EM-91
Intake and Exhaust valve clearance ★	NOTE (4)									EM-43	—

MAINTENANCE OPERATION		MAINTENANCE INTERVAL								Reference Section - Page or - Content Title	
Perform at number of miles, kilometers or months, whichever comes first.	Miles x 1,000	33.75 (54)	37.5 (60)	41.25 (66)	45 (72)	48.75 (78)	52.5 (84)	56.25 (90)	60 (96)	KA24DE	VG33E and VG33ER
	(km x 1,000)										
	Months										
Drive belts									I*	MA-15	MA-24
Air cleaner filter	NOTE (1)								[R]	MA-20	MA-30
Positive crankcase ventilation (PCV) filter	NOTE (2)								[R]	MA-23	—
EVAP vapor lines									I*	MA-23	MA-35
Fuel lines									I*	MA-18	MA-28
Fuel filter*	NOTE (2)									MA-18	MA-28
Engine coolant	NOTE (3)								R*	MA-16	MA-26
Engine oil		R	R	R	R	R	R	R	R	MA-20	MA-30
Engine oil filter (Use part No. 15208 31U00, 15208 9E000, 15208 7B000 or equivalent for VG engine.)		R	R	R	R	R	R	R	R	MA-21	MA-31
Spark plugs (Double PLATINUM-TIPPED type)										MA-22	MA-32
Timing belt										—	EM-91
Intake and Exhaust valve clearance ★	NOTE (4)									EM-43	—

NOTE:

- (1) If operating mainly in dusty conditions, more frequent maintenance may be required.
- (2) When the filter becomes clogged, the vehicle speed cannot be increased as the driver wishes. In such an event, replace the filter.
- (3) After 60,000 miles (96,000 km) or 48 months, replace every 30,000 miles (48,000 km) or 24 months.
- (4) If valve noises increases, inspect valve clearance.

★ Maintenance items and intervals with “*” are recommended by NISSAN for reliable vehicle operation. The owner need not perform such maintenance in order to maintain the emission warranty or manufacturer recall liability. Other maintenance items and intervals are required.

PERIODIC MAINTENANCE

Chassis and Body Maintenance

Abbreviations: R = Replace. I = Inspect. Correct or replace if necessary. L = Lubricate. []: At the mileage intervals only.

MAINTENANCE OPERATION		MAINTENANCE INTERVAL								Reference Section - Page or - Content Title
Perform at number of miles, kilometers or months, whichever comes first.	Miles x 1,000 (km x 1,000) Months	3.75 (6) 3	7.5 (12) 6	11.25 (18) 9	15 (24) 12	18.75 (30) 15	22.5 (36) 18	26.25 (42) 21	30 (48) 24	
Brake lines & cables					I				I	MA-41
Brake pads, rotors, drums & linings			I		I		I		I	MA-42 , MA-42
Automatic transmission fluid	NOTE (1)				I				I	MA-37
Transfer fluid & differential gear oil (exc. LSD)	NOTE (1)				I				I	MA-38 , MA-39
LSD gear oil	NOTE (2)				I				R	MA-40
Manual transmission gear oil	NOTE (1)				I				I	MA-36
Steering gear, linkage, axle & suspension parts			I		I		I		I	MA-43
Tire Rotation	NOTE (3)									MA-41
Drive shaft boots and propeller shaft (4x4)			I		I		I		I	MA-39
Propeller shaft (4x4)	NOTE (4)		L		L		L		L	MA-39
Front wheel bearing grease	4x2								I	MA-44
Front wheel bearing grease and free-running hub grease	4x4	NOTE (5)			I				R	MA-44
Exhaust system			I		I		I		I	MA-36
In-cabin microfilter					R				R	MTC-64

MAINTENANCE OPERATION		MAINTENANCE INTERVAL								Reference Section - Page or - Content Title
Perform at number of miles, kilometers or months, whichever comes first.	Miles x 1,000 (km x 1,000) Months	33.75 (54) 27	37.5 (60) 30	41.25 (66) 33	45 (72) 36	48.75 (78) 39	52.5 (84) 42	56.25 (90) 45	60 (96) 48	
Brake lines & cables					I				I	MA-41
Brake pads, rotors, drums & linings			I		I		I		I	MA-42 , MA-42
Automatic transmission fluid	NOTE (1)				I				I	MA-37
Transfer fluid & differential gear oil (exc. LSD)	NOTE (1)				I				I	MA-38 , MA-39
LSD gear oil	NOTE (2)				I				R	MA-40
Manual transmission gear oil	NOTE (1)				I				I	MA-36
Steering gear, linkage, axle & suspension parts			I		I		I		I	MA-43
Tire Rotation	NOTE (3)									MA-41
Drive shaft boots and propeller shaft (4x4)			I		I		I		I	MA-39
Propeller shaft (4x4)	NOTE (4)		L		L		L		L	MA-39

PERIODIC MAINTENANCE

MAINTENANCE OPERATION			MAINTENANCE INTERVAL							Reference Section - Page or - Content Title
Perform at number of miles, kilometers or months, whichever comes first.	Miles x 1,000 (km x 1,000)	33.75 (54)	37.5 (60)	41.25 (66)	45 (72)	48.75 (78)	52.5 (84)	56.25 (90)	60 (96)	
	Months	27	30	33	36	39	42	45	48	
Front wheel bearing grease	4x2								I	MA-44
Front wheel bearing grease and free-running hub grease	4x4	NOTE (5)				I			R	MA-44
Exhaust system			I		I		I		I	MA-36
In-cabin microfilter					R				R	MTC-64

NOTE:

- (1) If towing a trailer, using a camper or a car-top carrier, or driving on rough or muddy roads, change (not just inspect) oil at every 30,000 miles (48,000 km) or 24 months.
- (2) If towing a trailer, using a camper or a car-top carrier, or driving on rough or muddy roads, change (not just inspect) oil at every 30,000 miles (48,000 km) or 24 months, and change LSD gear oil every 15,000 miles (24,000 km) or 12 months.
- (3) Refer to "Tire rotation" under the "General maintenance" heading earlier in this section.
- (4) The propeller shaft should be re-greased after being immersed in water.
- (5) If operating frequently in water, replace grease every 3,750 miles (6,000 km) or 3 months.

SCHEDULE 2

Emission Control System Maintenance

Abbreviations: R = Replace. I = Inspect. Correct or replace if necessary. []: At the mileage intervals only

MAINTENANCE OPERATION		MAINTENANCE INTERVAL								Reference Section - Page or - Content Title	
Perform at number of miles, kilometers or months, whichever comes first.	Miles x 1,000 (km x 1,000)	7.5 (12)	15 (24)	22.5 (36)	30 (48)	37.5 (60)	45 (72)	52.5 (84)	60 (96)	KA24DE	VG33E and VG33ER
	Months	6	12	18	24	30	36	42	48		
Drive belts					I*				I*	MA-15	MA-24
Air cleaner filter					[R]				[R]	MA-20	MA-30
Positive crankcase ventilation (PCV) filter	NOTE (1)				[R]				[R]	MA-23	—
EVAP vapor lines					I*				I*	MA-23	MA-35
Fuel lines					I*				I*	MA-18	MA-28
Fuel filter*	NOTE (1)									MA-18	MA-28
Engine coolant	NOTE (2)								R*	MA-16	MA-26
Engine oil		R	R	R	R	R	R	R	R	MA-20	MA-30
Engine oil filter (Use part No. 15208 31U00, 15208 9E000, 15208 7B000, or equivalent for VG engine.)		R	R	R	R	R	R	R	R	MA-21	MA-31
Spark plugs (Double PLATINUM-TIPPED type)		Replace every 105,000 miles (169,000 km)								MA-22	MA-32
Timing belt		Replace every 105,000 miles (169,000 km)								—	EM-91
Intake and Exhaust valve clearance ★	NOTE (3)									EM-43	—

NOTE:

- (1) When the filter becomes clogged, the vehicle speed cannot be increased as the driver wishes. In such an event, replace the filter.
- (2) After 60,000 miles (96,000 km) or 48 months, replace every 30,000 miles (48,000 km) or 24 months.

PERIODIC MAINTENANCE

- (3) If valve noises increase, inspect valve clearance.

★ Maintenance items and intervals with “*” are recommended by NISSAN for reliable vehicle operation. The owner need not perform such maintenance in order to maintain the emission warranty or manufacturer recall liability. Other maintenance items and intervals are required.

Chassis and Body Maintenance

Abbreviations: R = Replace. I = Inspect. Correct or replace if necessary. L = Lubricate. []: At the mileage interval only.

MAINTENANCE OPERATION	Miles x 1,000 (km x 1,000) Months	MAINTENANCE INTERVAL								Reference Section - Page or - Content Title
		7.5 (12) 6	15 (24) 12	22.5 (36) 18	30 (48) 24	37.5 (60) 30	45 (72) 36	52.5 (84) 42	60 (96) 48	
Brake lines & cables			I		I		I		I	MA-41
Brake pads, rotors, drums & linings			I		I		I		I	MA-42 , MA-42
Automatic transmission fluid			I		I		I		I	MA-37
Transfer fluid & differential gear oil (exc. LSD)			I		I		I		I	MA-38 , MA-39
LSD gear oil			I		R		I		R	MA-40
Manual transmission gear oil			I		I		I		I	MA-36
Steering gear, linkage, axle & suspension parts.					I				I	MA-43
Tire rotation	NOTE (1)									MA-41
Drive shaft boots and propeller shaft (4x4)			I		I		I		I	MA-39
Propeller shaft (4x4)	NOTE (2)		L		L		L		L	MA-39
Front wheel bearing grease (4x2)					I				I	MA-44
Front wheel bearing grease and free-running hub grease(4x4)			I		R		I		R	MA-44
Exhaust system					I				I	MA-36
In-cabin microfilter			R		R		R		R	MTC-64

NOTE:

- (1) Refer to “Tire rotation” under the “General maintenance” heading earlier in this section.
- (2) The propeller shaft should be re-greased after being immersed in water.

RECOMMENDED FLUIDS AND LUBRICANTS

PFP:00000

ELS000ES

RECOMMENDED FLUIDS AND LUBRICANTS

Recommended Fluids and Lubricants FLUIDS AND LUBRICANTS

KA24DE

Description			Capacity (Approximate)			Recommended Fluids and Lubricants
			US measure	Imp measure	Liter	
Engine oil	Drain and Refill	With oil filter	3 3/4 qt	3 1/8 qt	3.5	<ul style="list-style-type: none"> ● API Certification Mark*1 ● API grade SG/SH, Energy Conserving I & II or API grade SJ or SL, Energy Conserving*1 ● ILSAC grade GF-I, GF-II & GF-III*1
		Without oil filter	3 1/2 qt	2 7/8 qt	3.3	
	Dry engine (Engine overhaul)		4 1/2 qt	3 3/4 qt	4.1	
Cooling system (without reservoir)		MT	6 7/8 qt	5 3/4 qt	6.5	Genuine NISSAN Long Life Anti-freeze coolant or equivalent
		AT	6 5/8 qt	5 1/2 qt	6.3	
Cooling system reservoir		MT and AT	7/8 qt	3/4 qt	0.8	
Manual transmission fluid (MTF) (FS5W71C)			4 1/4 pt	3 1/2 pt	2.0	Genuine NISSAN Manual Transmission Fluid (MTF) HQ Multi 75W-85 or equivalent
Differential carrier gear oil		C200	2 3/8 pt	2 1/4 pt	1.3	Standard differential gear: API GL-5 Viscosity SAE 80W-90*3 Limited-slip differential (LSD) gear: Use only LSD gear oil API GL-5 Viscosity SAE 80W-90*3 approved for NISSAN LSD*4.
Automatic transmission fluid (ATF)			8 3/8 qt	7 qt	7.9	Genuine NISSAN Matic "D" ATF (Continental U.S. and Alaska) or Canada NISSAN Automatic Transmission Fluid *5
Power steering fluid (PSF)			1 7/8 - 2 1/8 pt	1 5/8 - 1 3/4 pt	0.9 - 1.0	Genuine NISSAN PSF or equivalent*6
Brake and clutch fluid			—	—	—	Genuine NISSAN Super Heavy Duty Brake Fluid*2 or equivalent DOT 3 (US FMVSS No. 116)
Multi-purpose grease			—	—	—	NLGI No. 2 (Lithium soap base)
Windshield washer fluid			—	—	—	Genuine NISSAN Windshield Washer Concentrate Cleaner & Anti-freeze
Air conditioner system refrigerant			1.32 - 1.54 lb	1.32 - 1.54 lb	0.60 - 0.70 kg	HFC 134a (R-134a)*7
Air conditioner system lubricant			6.8 fl oz	7.0 fl oz	200 mℓ	Genuine NISSAN A/C System Lubricant Type R or equivalent*7

*1: For further details, see "SAE Viscosity Number".

*2: Available in mainland U.S.A. through your NISSAN dealer.

*3: For hot climates, viscosity SAE 90 is suitable for ambient temperatures above 0°C (32°F).

*4: Contact a NISSAN dealer for a list of approved oils.

*5: DEXRON™ III, MERCON™ or equivalent may also be used. Outside the Continental United States and Alaska contact a NISSAN dealership for more information regarding suitable fluids, including recommended brand(s) of DEXRON™ III, MERCON™ Automatic Transmission Fluid.

*6: Genuine NISSAN PSF, Canada NISSAN Automatic Transmission Fluid (ATF), DEXRON™ III, MERCON™, or equivalent ATF may also be used.

*7: For further details, see "Air conditioner specification label."

RECOMMENDED FLUIDS AND LUBRICANTS

VG33E and VG33ER

Description			Capacity (Approximate)			Recommended Fluids and Lubricants
			US measure	Imp measure	Liter	
Engine oil	Drain and refill	With oil filter	3 1/2 qt	2 7/8 qt	3.3	<ul style="list-style-type: none"> ● API Certification Mark*1 ● API grade SG/SH, Energy Conserving I & II or API grade SJ or SL, Energy Conserving*1 ● ILSAC grade GF-I, GF-II & GF-III*1
		Without oil filter	3 1/8 qt	2 5/8 qt	3.0	
	Dry engine (engine overhaul)		4 qt	3 3/8 qt	3.8	
Cooling system (without reservoir)			10 3/4 qt	8 7/8 qt	10.15	Genuine NISSAN Long Life Anti-freeze coolant or equivalent
Cooling system reservoir			7/8 qt	3/4 qt	0.8	
Manual transmission fluid (MTF) (FS5R30A)	2WD		5 7/8 pt	4 7/8 pt	2.8	Genuine NISSAN Manual Transmission Fluid (MTF) HQ Multi 75W-85 or equivalent
	4WD		10 3/4 pt	9 pt	5.1	
Transfer fluid (TX10A)			2 3/8 qt	2 qt	2.2	Genuine NISSAN Matic "D" ATF (Continental U.S. and Alaska) or Canada NISSAN Automatic Transmission Fluid*2 or API GL-4, Viscosity SAE 75W-85 or 75W-90
Differential carrier gear oil	Front (4WD) R200A		3 3/4 pt	3 1/8 pt	1.75	Standard differential gear: API GL-5 Viscosity SAE 80W-90*4 Limited-slip differential (LSD) gear: Use only LSD gear oil API GL-5 Viscosity SAE 80W-90*4 approved for NISSAN LSD*5.
	Rear H233B		5 7/8 pt	4-7/8 pt	2.8	
Automatic transmission fluid (ATF)	2WD		8 3/4 qt	7 1/4 qt	8.3	Genuine NISSAN Matic "D" ATF (Continental U.S. and Alaska) or Canada NISSAN Automatic Transmission Fluid *2
	4WD		9 qt	7 1/2 qt	8.5	
Power steering fluid (PSF)			2 1/8 - 2 3/8 pt	1 3/4 - 2 pt	1.0 - 1.1	Genuine NISSAN PSF or equivalent*6
Brake and clutch fluid			—	—	—	Genuine NISSAN Super Heavy Duty Brake Fluid*3 or equivalent DOT 3 (US FMVSS No. 116)
Propeller shaft grease			—	—	—	NLGI No. 2 (Molybdenum disulphide lithium soap base)
Multi-purpose grease			—	—	—	NLGI No. 2 (Lithium soap base)
Free-running hub grease (Auto-lock)			—	—	—	Genuine NISSAN grease or equivalent
Windshield washer fluid			—	—	—	Genuine NISSAN Windshield Washer Concentrate Cleaner & Anti-freeze
Air conditioner system refrigerant			1.32 - 1.54 lb	1.32 - 1.54 lb	0.60 - 0.70 kg	HFC 134a (R-134a)*7
Air conditioner system lubricant			6.8 fl oz	7.0 fl oz	200 m ℓ	Genuine NISSAN A/C System Lubricant Type R or equivalent*7

*1: For further details, see "SAE Viscosity Number".

*2: DEXRON™ III, MERCON™ or equivalent may also be used. Outside the continental United States and Alaska contact a NISSAN dealership for more information regarding suitable fluids, including recommended brand(s) of DEXRON™ III, MERCON™ Automatic Transmission Fluid.

*3: Available in mainland U.S.A. through your NISSAN dealer.

*4: For hot climates, viscosity SAE 90 is suitable for ambient temperatures above 0°C (32°F).

*5: Contact a NISSAN dealer for a list of approved oils.

*6: Genuine NISSAN PSF, Canada NISSAN Automatic Transmission Fluid (ATF), DEXRON™ III, MERCON™, or equivalent ATF may also be used.

*7: For further details, see "Air conditioner specification label."

RECOMMENDED FLUIDS AND LUBRICANTS

SAE VISCOSITY NUMBER

Gasoline Engine Oil

SAE 5W-30 viscosity oil is preferred for all ambient temperatures. SAE 10W-30 and 10W-40 viscosity oil may be used if the ambient temperature is above -18°C (0°F).

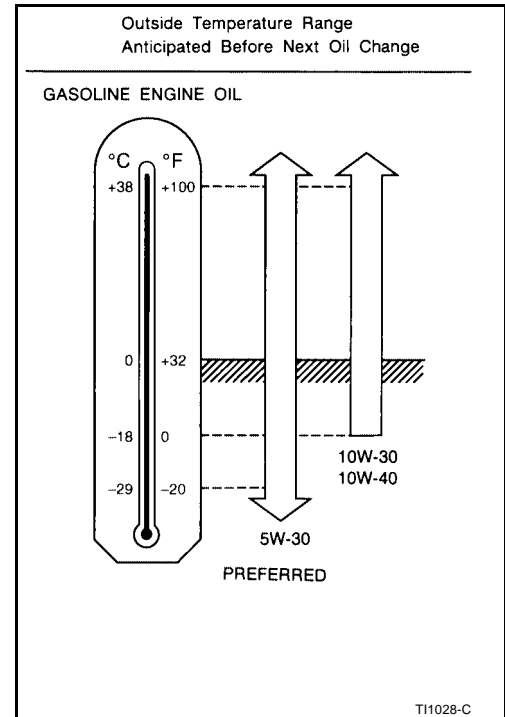

ANTI-FREEZE COOLANT MIXTURE RATIO

The engine cooling system is filled at the factory with a high-quality, year-round, long life, anti-freeze coolant solution. The anti-freeze solution contains rust and corrosion inhibitors. Therefore, additional cooling system additives are not necessary.

CAUTION:

- When adding or replacing coolant, be sure to use only a Genuine NISSAN Long Life Anti-freeze coolant or equivalent with the proper mixture.

Outside temperature down to		Genuine NISSAN Long Life Anti-freeze coolant or equivalent	Demineralized water or distilled water
$^{\circ}\text{C}$	$^{\circ}\text{F}$		
-35	-30	50%	50%

- Other types of coolant solutions may damage the engine cooling system.

ENGINE MAINTENANCE (KA24DE)

Checking Drive Belts

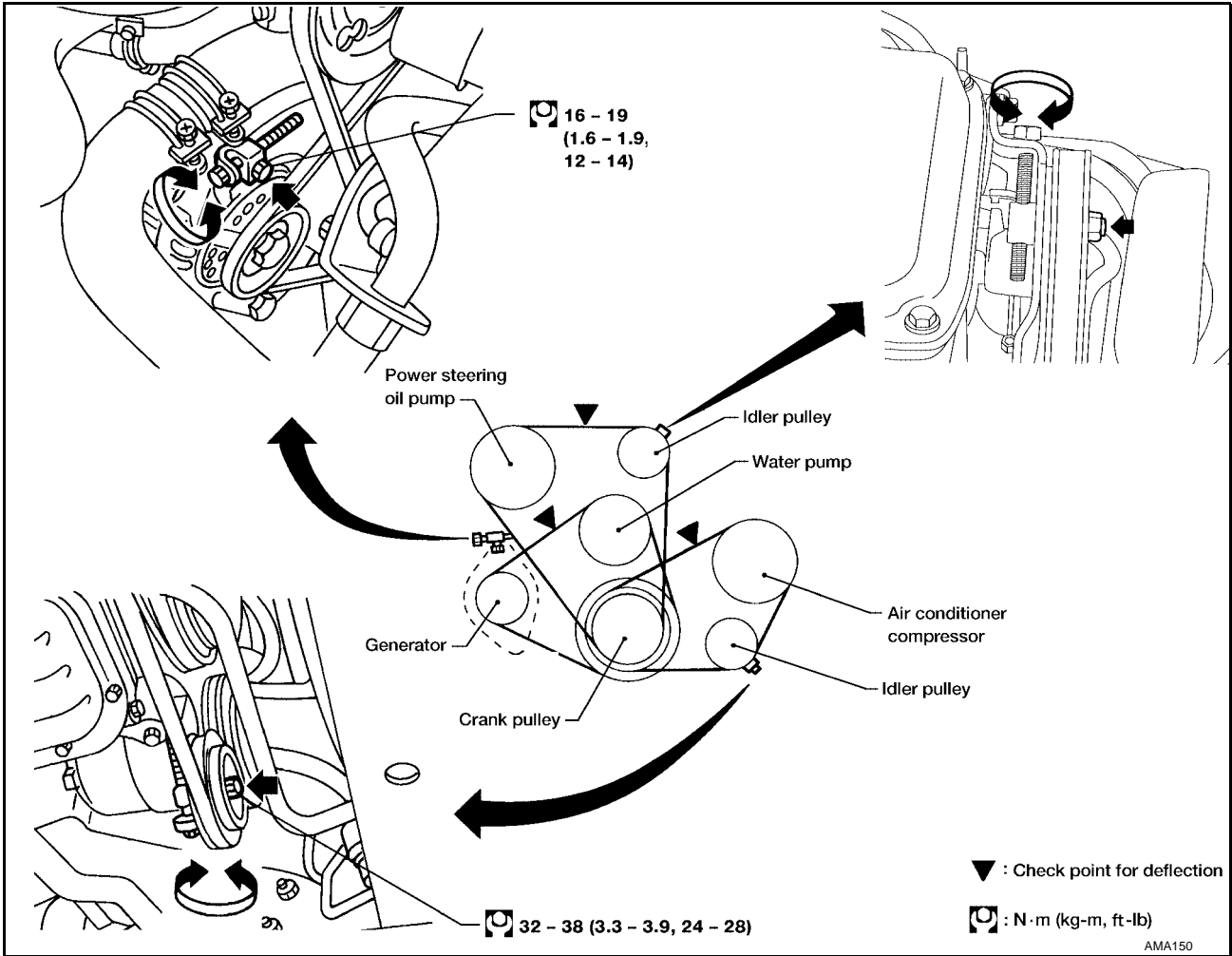

1. Inspect belt for cracks, fraying, wear and oil. If necessary, replace.
2. Inspect drive belt deflection or tension at a point on the belt midway between pulleys using Tool.

Tool number : BT-3373-F

NOTE:

- Inspect drive belt deflection or tension when engine is cold.
- Adjust if belt deflections exceed the limit or if belt tension is not within specifications.
- Drive belt tension can be checked at other points on the belt.

A
B
C
D
E
F
G
H
I
J
K
MA
M

ENGINE MAINTENANCE (KA24DE)

DRIVE BELT DEFLECTION AND TENSION

	Deflection adjustment Unit: mm (in)			Tension adjustment *1 Unit: N (kg, lb)		
	Used belt		New belt	Used belt		New belt
	Limit	After adjustment		Limit	After adjustment	
Generator	17 (0.67)	10 - 12 (0.39 - 0.47)	8 - 10 (0.31 - 0.39)	222.4 (22.7, 50)	355.8 - 444.8 (36.3 - 45.4, 80 - 100)	489.3 - 578.2 (49.9 - 59.0, 110 - 130)
Air conditioner compressor	16 (0.63)	10 - 12 (0.39 - 0.47)	8 - 10 (0.31 - 0.39)	200.2 (20.4, 45)	355.8 - 444.8 (36.3 - 45.4, 80 - 100)	489.3 - 578.2 (49.9 - 59.0, 110 - 130)
Power steering oil pump	17 (0.67)	10 - 13 (0.39 - 0.51)	8 - 10 (0.31 - 0.39)	222.4 (22.7, 50)	355.8 - 444.8 (36.3 - 45.4, 80 - 100)	489.3 - 578.2 (49.9 - 59.0, 110 - 130)
Applied pushing force	98 N (10 kg, 22 lb)			—		

*1: If belt tension gauge cannot be installed at check point shown, check belt tension at a different location on the belt.

Changing Engine Coolant

ELS000MR

WARNING:

- To avoid being scalded, never change the coolant when the engine is hot.
- Wrap a thick cloth around cap and carefully remove the cap. First, turn the cap a quarter of a turn to release built-up pressure. Then push down and turn the cap all the way to remove.

DRAINING ENGINE COOLANT

1. Turn ignition switch ON and set temperature control lever all the way to HOT position or the highest temperature position. Wait 10 seconds and turn ignition switch OFF.
2. Open the radiator drain plug at the bottom of the radiator, and remove the radiator filler cap. This is the only step required when partially draining the cooling system (radiator only).
 - Do not to allow the coolant to contact the drive belts.

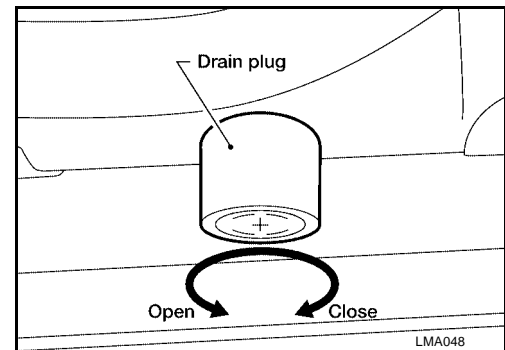

LMA048

3. When draining all of the coolant in the system for engine removal or repair, remove cylinder block drain plug and air relief plug.

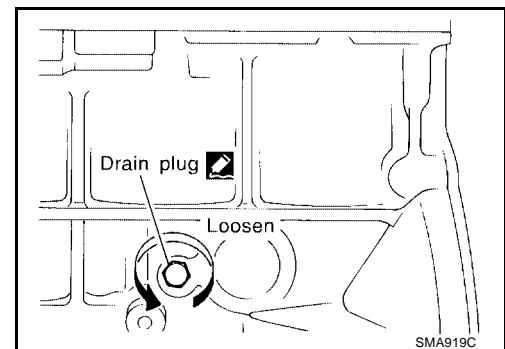

SMA919C

ENGINE MAINTENANCE (KA24DE)

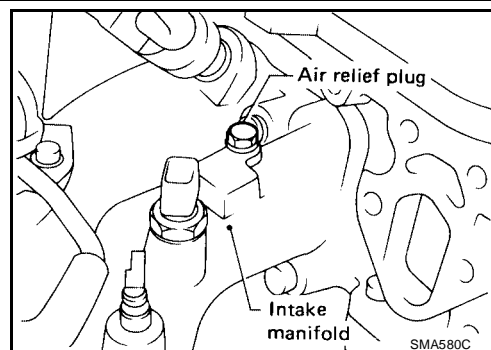

4. Check the drained coolant for contaminants such as rust, corrosion or discoloration. If the coolant is contaminated, flush the engine cooling system. Refer to [MA-18, "FLUSHING COOLING SYSTEM"](#).

REFILLING ENGINE COOLANT

- Install the radiator drain plug. Install the reservoir tank and cylinder block drain plug, if removed for a total system drain or for engine removal or repair.
 - The radiator must be completely empty of coolant and water.
 - Apply sealant to the threads of the cylinder block drain plugs. Use Genuine High Performance Thread Sealant or equivalent. Refer to [GI-42, "RECOMMENDED CHEMICAL PRODUCTS AND SEALANTS"](#).

Radiator drain plug : 7.8 - 11.8 N-m (0.8 - 1.2 kg-m , 69 - 104 in-lb)

Cylinder block drain plug : 34 - 44 N-m (3.5 - 4.5 kg-m, 25 - 33 ft-lb)

Air relief plug : 7 - 8 N-m (0.7 - 0.8 kg-m, 61 - 69 in-lb)

- If disconnected, reattach the upper radiator hose at the engine side.
- Set the vehicle heater controls to the full HOT and heater ON position. Turn the vehicle ignition ON with the engine OFF as necessary to activate the heater mode.
- Install the Tool by installing the radiator cap adapter onto the radiator neck opening. Then attach the gauge body assembly with the refill tube and the venturi assembly to the radiator cap adapter.
- Insert the refill hose into the coolant mixture container that is placed at floor level. Make sure the ball valve is in the closed position.
 - Use Genuine NISSAN Long Life Anti-freeze coolant or equivalent, mixed 50/50 with distilled water or demineralized water. Refer to [MA-14, "ANTI-FREEZE COOLANT MIXTURE RATIO"](#).

Engine coolant capacity

MT (without reservoir tank) : 6.5 ℓ (6 7/8 US qt, 5 3/4 Imp qt)

AT (without reservoir tank) : 6.3 ℓ (6 5/8 US qt, 5 1/2 Imp qt)

Reservoir tank : 0.8 ℓ (7/8 US qt, 3/4 Imp qt)

- Install an air hose to the venturi assembly; the air pressure must be within specification.

Compressed air supply pressure : 5.7 - 8.5 kPa (5.6 - 8.4 kg/cm², 80 - 120 psi)

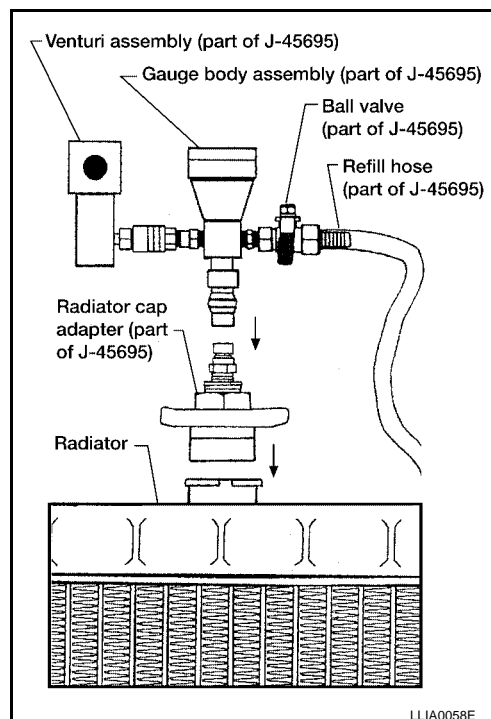

CAUTION:

The compressed air supply must be equipped with an air dryer.

ENGINE MAINTENANCE (KA24DE)

- The vacuum gauge will begin to rise and there will be an audible hissing noise. During this process open the ball valve on the refill hose slightly. Coolant will be visible rising in the refill hose. Once the refill hose is full of coolant, close the ball valve. This will purge any air trapped in the refill hose.
- Continue to draw the vacuum until the gauge reaches 28 inches of vacuum. The gauge may not reach 28 inches in high altitude locations; refer to the vacuum specifications based on the altitude above sea level.

Altitude above sea level	Vacuum gauge reading
0 - 100 m (328 ft)	: 28 inches of vacuum
300 m (984 ft)	: 27 inches of vacuum
500 m (1,641 ft)	: 26 inches of vacuum
1,000 m (3,281 ft)	: 24 - 25 inches of vacuum

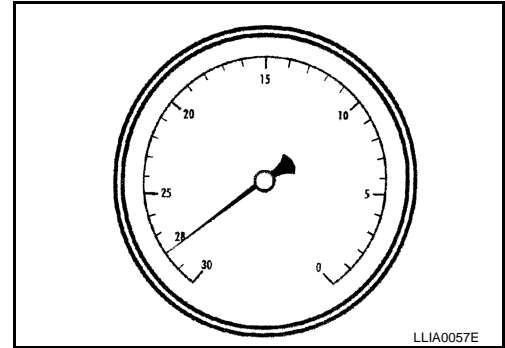

- When the vacuum gauge has reached the specified amount, disconnect the air hose and wait 20 seconds to see if the system loses any vacuum. If the vacuum level drops, perform any necessary repairs to the system and repeat steps 6 - 8 to bring the vacuum to the specified amount. Recheck for any leaks.
- Place the coolant container (with the refill hose inserted) at the same level as the top of the radiator. Then open the ball valve on the refill hose so the coolant will be drawn up to fill the cooling system. The cooling system is full when the vacuum gauge reads zero.

CAUTION:

Do not allow the coolant container to get too low when filling, to avoid air from being drawn into the cooling system.

- Remove the Tool from the radiator neck opening.
- Fill the cooling system reservoir tank to the specified level. Run the engine to warm up the cooling system and top up the system as necessary before installing the radiator cap.

FLUSHING COOLING SYSTEM

- Fill the radiator from the filler cap above the radiator upper hose and reservoir tank, with water and reinstall the filler cap above the radiator upper hose.
- Run the engine until it reaches normal operating temperature.
- Press the engine accelerator two or three times under no-load.
- Stop the engine and wait until it cools down.
- Drain the water.
- Repeat steps 1 through 5 until clear water begins to drain from the radiator.

Checking Fuel Lines

ELS000MS

Inspect fuel lines and tank for improper attachment, leaks, cracks, damage, chafing and deterioration. If necessary, repair or replace.

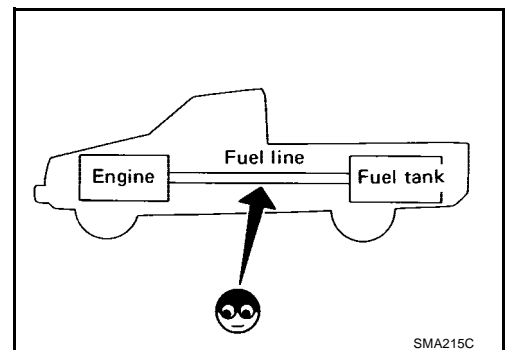

Changing Fuel Filter

ELS000MT

WARNING:

Before removing fuel filter, release fuel pressure from fuel line.

Ⓢ WITH CONSULT - II

- Start engine.

ENGINE MAINTENANCE (KA24DE)

- Perform "FUEL PRESSURE RELEASE" in "WORK SUPPORT" mode to release fuel pressure to zero.

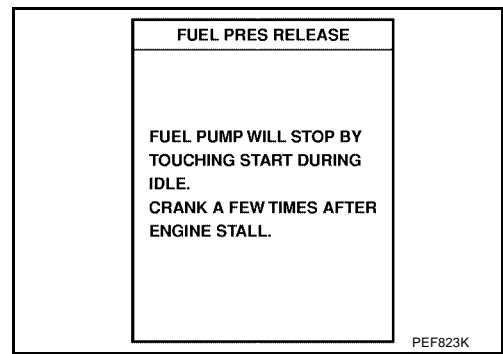

- After engine stalls, crank engine two or three times to make sure that fuel pressure is released.
- Turn ignition switch "OFF".
- Remove the fuel filter shield.
- Loosen fuel hose clamps.
- Replace fuel filter.

- Use a high-pressure type fuel filter. Do not use a synthetic resinous fuel filter.

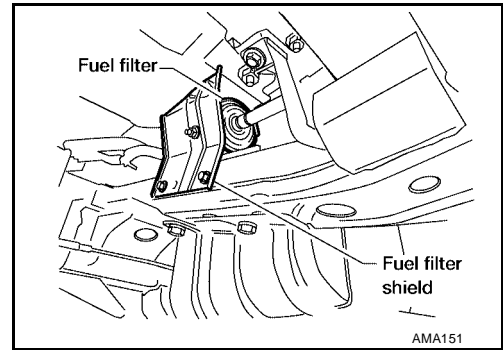

- Tighten fuel hose clamps.

Fuel hose clamps : 1.0 - 1.5 N·m (0.1 - 0.15 kg-m, 8.7 - 13.0 in-lb)

CAUTION:

Tighten high-pressure rubber hose clamp so that clamp end is 3 mm (0.12 in) from hose end.

Tightening torque specifications are the same for all rubber hose clamps.

Ensure that the screw does not contact adjacent parts.

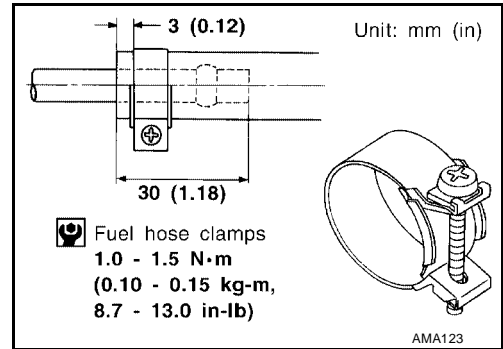

⊗ WITHOUT CONSULT - II

- Remove fuel pump fuse. For correct fuse location, refer to label on fuse block cover.
- Start engine.
- After engine stalls, crank engine two or three times to make sure that fuel pressure is released.
- Turn ignition switch "OFF" and install fuel pump fuse.

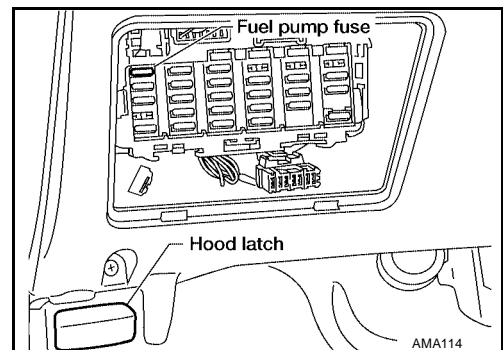

A
B
C
D
E
F
G
H
I
J
K
MA
M

ENGINE MAINTENANCE (KA24DE)

- Remove the fuel filter shield.

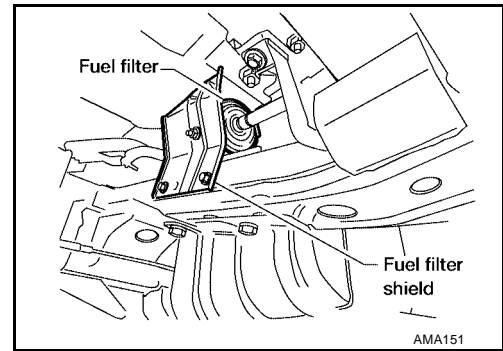

- Loosen fuel hose clamps.
- Replace fuel filter.
 - Use a high-pressure type fuel filter. Do not use a synthetic resinous fuel filter.
- Tighten fuel hose clamps.

Fuel hose clamps : 1.0 - 1.5 N·m (0.1 - 0.15 kg·m,
8.7 - 13.0 in-lb)

CAUTION:

Tighten high-pressure rubber hose clamp so that clamp end is 3 mm (0.12 in) from hose end.

Tightening torque specifications are the same for all rubber hose clamps.

Ensure that the screw does not contact adjacent parts.

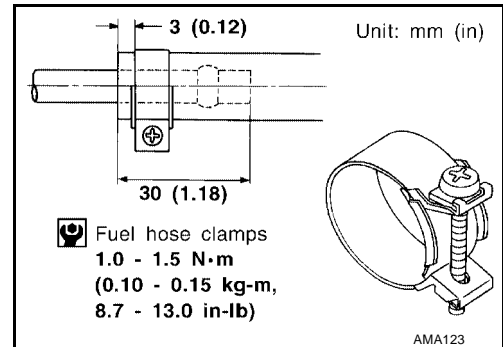

Changing Air Cleaner Filter

ELS000MU

The viscous paper type filter does not need cleaning between renewals.

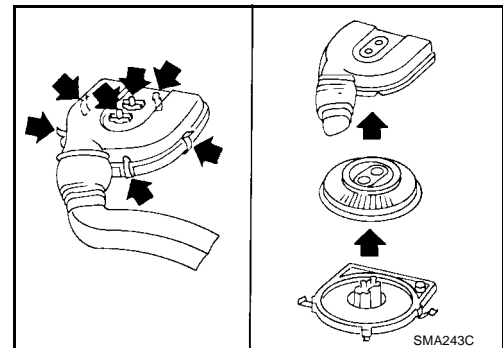

Changing Engine Oil

ELS000MV

WARNING:

- Be careful not to burn yourself, as the engine oil is hot.
 - Prolonged and repeated contact with used engine oil may cause skin cancer; try to avoid direct skin contact with used oil. If skin contact is made, wash thoroughly with soap or hand cleaner as soon as possible.
- Warm up engine, and check for oil leakage from engine components.
 - Remove drain plug and oil filler cap.
 - Drain oil and refill with new engine oil.

Oil Specification and Viscosity

- API Certification Mark
- API grade SG/SH, Energy Conserving I & II or API grade SJ or SL, Energy Conserving.
- ILSAC grade GF-I, GF-II & GF-III
- Refer to [MA-12, "RECOMMENDED FLUIDS AND LUBRICANTS"](#).

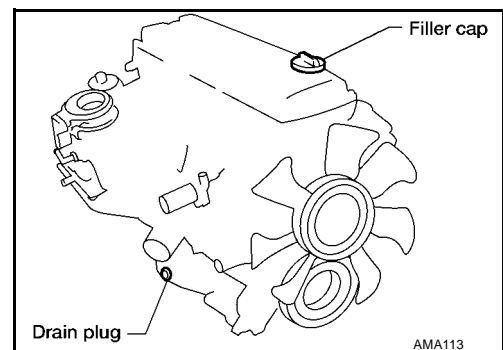

ENGINE MAINTENANCE (KA24DE)

Oil Capacity (Approximately)

Unit: ℓ (US qt, Imp qt)

Drain and refill	With oil filter change	3.5 (3 3/4, 3 1/8)
	Without oil filter change	3.3 (3 1/2, 2 7/8)
Dry engine (engine overhaul)		4.1 (4 1/2, 3 3/4)

CAUTION:

- Be sure to clean drain plug and install with new washer.

Drain plug : 29.4 - 39.2 N·m (3.0 - 4.0 kg·m, 21.69 - 28.91 ft·lb)

- The refill capacity depends on the oil temperature and drain time. Use these specifications for reference only. Always use the dipstick to determine when the proper amount of oil is in the engine.

4. Check oil level.
5. Start engine and check area around drain plug and oil filter for oil leakage.
6. Run engine for a few minutes, then turn it off. After several minutes, check oil level.

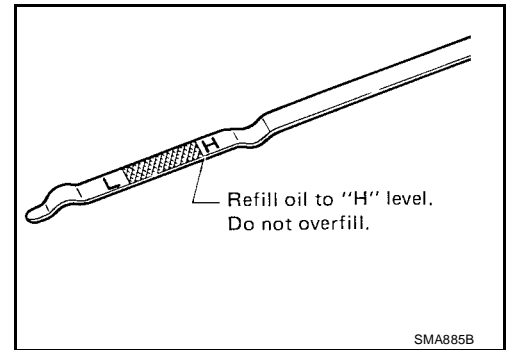

ELS000MW

Changing Oil Filter

1. Remove oil filter using Tool.

Tool number : KV10115801 (J-38956)

WARNING:

Be careful not to burn yourself. Engine and engine oil are hot.

The filter is a full-flow cartridge type and is provided with a relief valve.

2. Clean oil filter mounting surface on cylinder block. Coat rubber seal of new oil filter with engine oil.

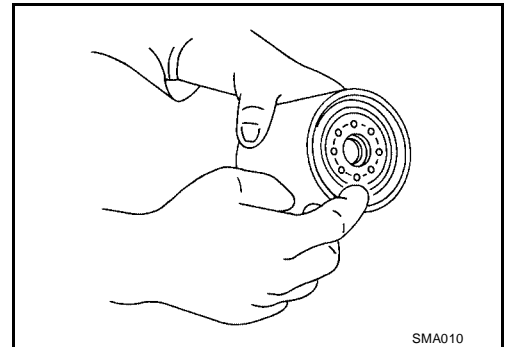

3. Screw in the oil filter until a slight resistance is felt, then tighten additionally more than 2/3 of a turn.
4. Add engine oil. Refer to [MA-20, "Changing Engine Oil"](#) .
 - Clean excess oil from engine.

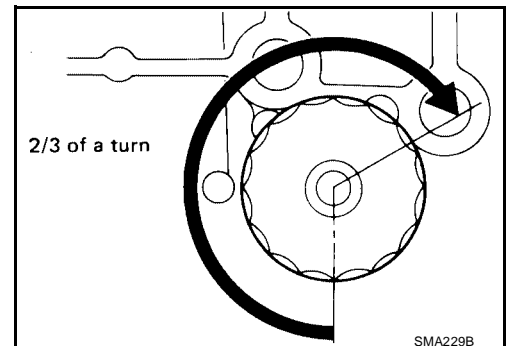

ENGINE MAINTENANCE (KA24DE)

ELS000MX

Changing Spark Plugs

1. Disconnect ignition wires from spark plugs at boot.

CAUTION:
Do not pull on the wire.

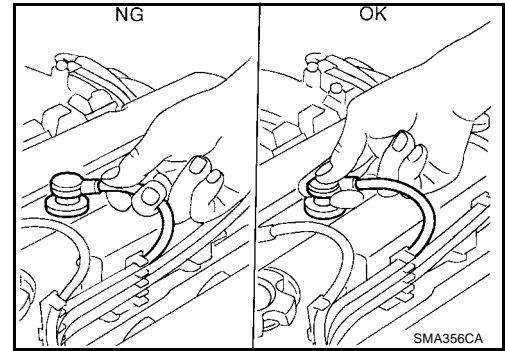

2. Remove spark plugs with spark plug wrench.

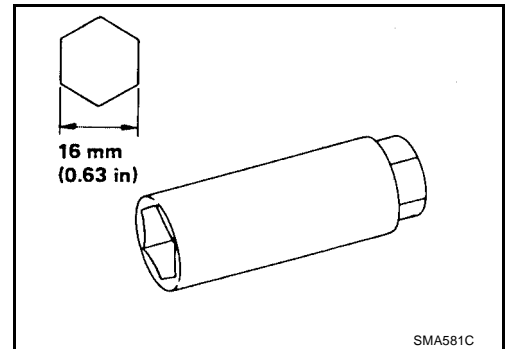

Spark Plug

Make	NGK (double platinum tipped)
Standard type	PFR5G-11
Cold type	PFR6G-11

Use standard type spark plug under normal conditions.

The cold type spark plug is suitable when spark knock occurs with the standard type spark plug under conditions such as:

- extended highway driving
- frequent high engine revolution
- Do not use a wire brush for cleaning.
- If plug tip is covered with carbon, spark plug cleaner may be used.

Cleaner air pressure : Less than 588 kPa (6 kg/cm² , 85 psi)

Cleaning time : Less than 20 seconds

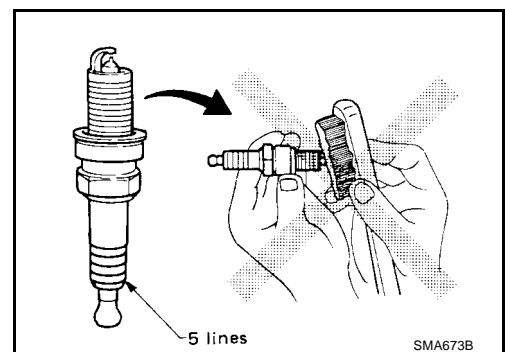

ENGINE MAINTENANCE (KA24DE)

- Checking and adjusting plug gap is not required between change intervals.

Spark plug gap (nominal) :1.1 mm (0.043 in)

3. Install spark plugs. Reconnect ignition wires according to numbers indicated on them.

Spark plug : 20 - 29 N·m (2.0 - 3.0 kg·m, 14 - 22 ft·lb)

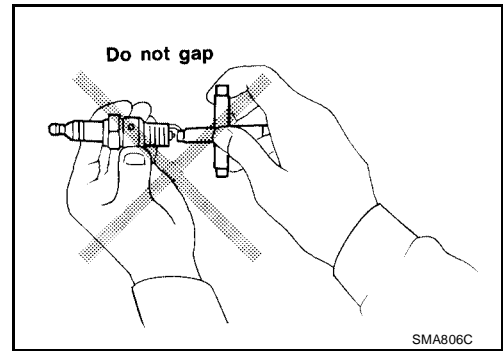

Checking EVAP Vapor Lines

1. Visually inspect EVAP vapor lines for improper attachment and for cracks, damage, loose connections, chafing and deterioration.
2. Inspect fuel tank filler cap vacuum relief valve for clogging, sticking, etc.
Refer to [EC-567, "EVAPORATIVE EMISSION SYSTEM"](#).

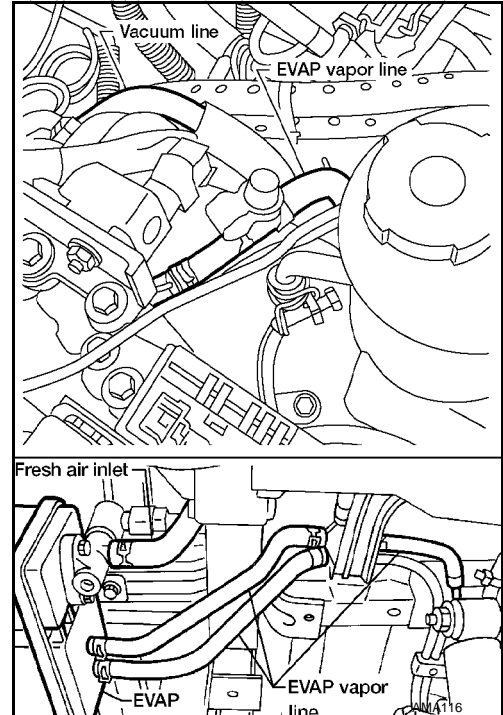

Changing Positive Crankcase Ventilation (PCV) Filter

Remove air cleaner cover and take out PCV filter located inside air cleaner cover. Then install new PCV filter.

ENGINE MAINTENANCE (VG33E AND VG33ER)

ENGINE MAINTENANCE (VG33E AND VG33ER)

PF1:10001

Checking Drive Belts

ELS000SH

VG33E

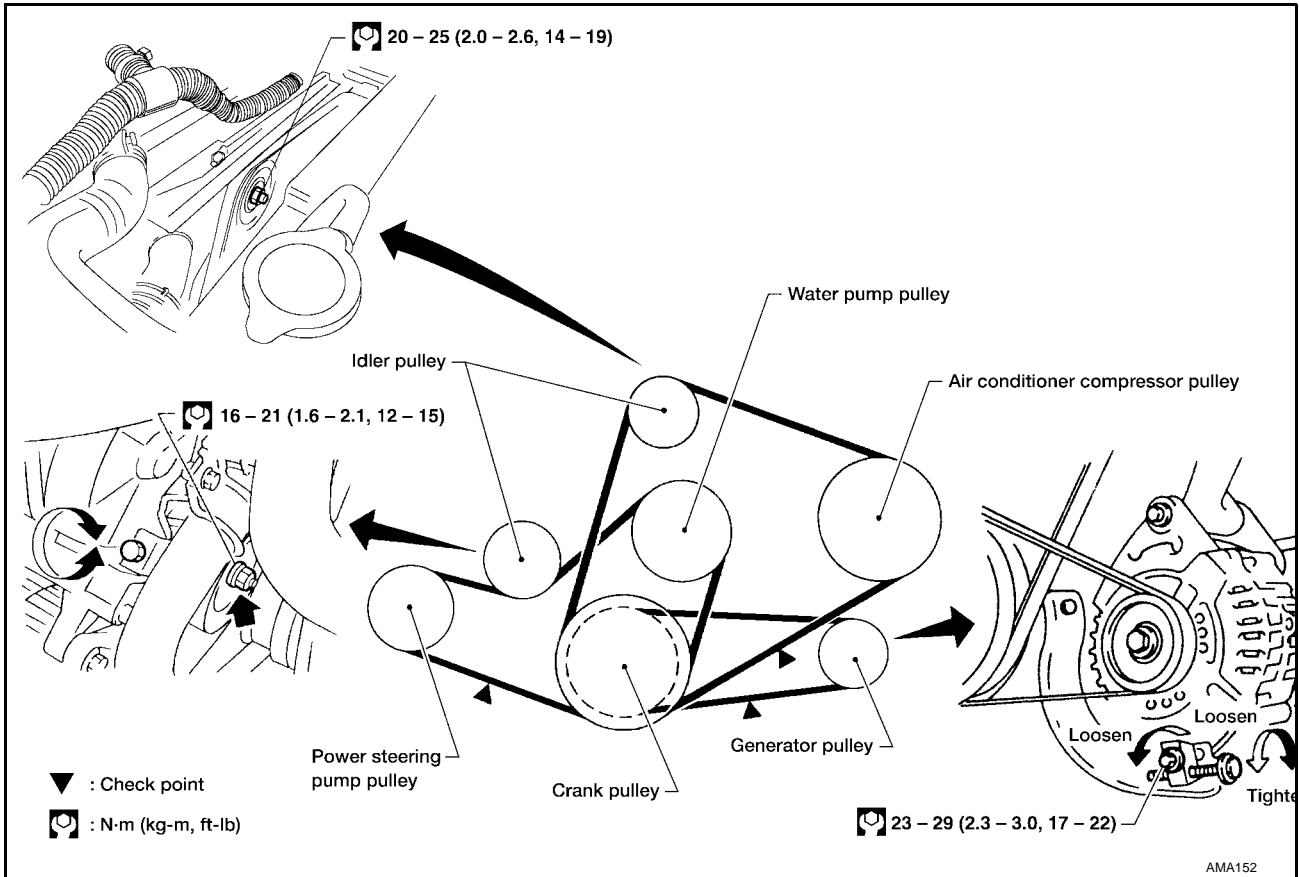

ENGINE MAINTENANCE (VG33E AND VG33ER)

VG33ER

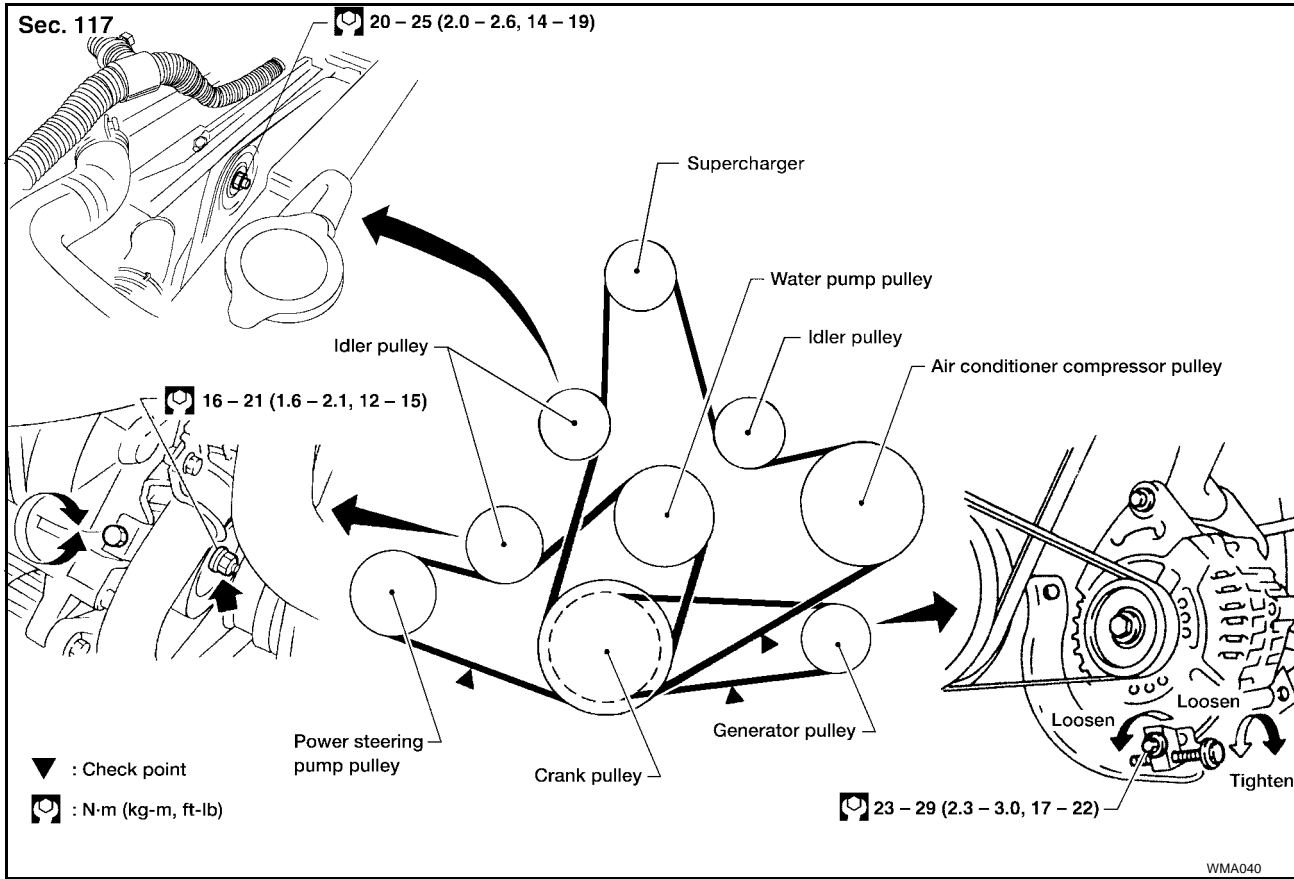

1. Inspect belt for cracks, fraying, wear and oil. If necessary, replace.
2. Inspect drive belt deflection or tension at a point on the belt midway between pulleys using Tool.

Tool number : BT-3373-F

NOTE:

- Inspect drive belt deflection or tension when engine is cold.
- Adjust if belt deflections exceed the limit or if belt tension is not within specifications
- Drive belt tension can be checked at other points on the belt.

DRIVE BELT DEFLECTION AND TENSION

	Deflection adjustment Unit: mm (in)			Tension adjustment *1 Unit: N (kg, lb)		
	Used belt		New belt	Used belt		New belt
	Limit	After adjustment		Limit	After adjustment	
Generator	11 (0.43)	7 - 8 (0.24 - 0.31)	6 - 7 (0.24 - 0.28)	226 (23, 51)	554.1 - 642.4 (56.5 - 65.5, 124.6 - 144.4)	671.8 - 760.0 (68.5 - 77.5, 151.0 - 170.9)
Air conditioner compressor - VG33E	18 (0.71)	12 - 13 (0.47 - 0.51)	10.5 - 11.5 (0.413 - 0.453)	196 (20, 44)	495.3 - 583.5 (50.5 - 59.5, 111.4 - 131.2)	603.1 - 691.4 (61.5 - 70.5, 135.6 - 155.5)
Air conditioner compressor and supercharger - VG33ER	16.5 (0.65)	9.5 - 10.5 (0.374 - 0.413)	8.5-9.5 (0.33 - 0.37)	294 (30, 66)	730 - 818 (75.5 - 83.5, 166.5 - 184.1)	838 - 926 (85.5 - 94.5, 188.5 - 208.4)
Power steering oil pump	15 (0.59)	9.5 - 10.5 (0.374 - 0.413)	8 - 9 (0.31 - 0.35)	275 (28, 62)	554.1 - 642.4 (56.5 - 65.5, 124.6 - 144.4)	671.8 - 760.0 (68.5 - 77.5, 151.0 - 170.9)
Applied pushing force	98 N (10 kg, 22 lb)			—		

*1: If belt tension gauge cannot be installed at check point shown, check belt tension at a different location on the belt.

ENGINE MAINTENANCE (VG33E AND VG33ER)

ELS000SI

Changing Engine Coolant

WARNING:

- To avoid being scalded, never change the coolant when the engine is hot.
- Wrap a thick cloth around cap and carefully remove the cap. First, turn the cap a quarter of a turn to release built-up pressure. Then push down and turn the cap all the way to remove.

DRAINING ENGINE COOLANT

1. Turn ignition switch ON and set temperature control lever all the way to HOT position or the highest temperature position. Wait 10 seconds and turn ignition switch OFF.
2. Open the radiator drain plug at the bottom of the radiator, and remove the radiator filler cap. This is the only step required when partially draining the cooling system (radiator only).
 - Do not to allow the coolant to contact the drive belts.

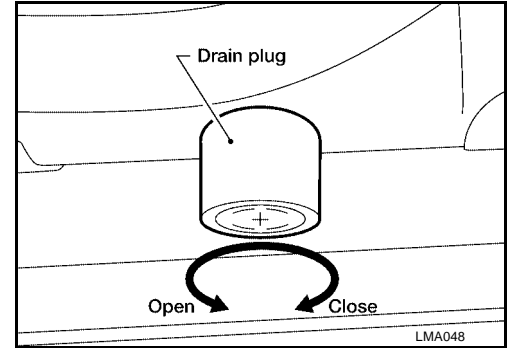

3. When draining all of the coolant in the system for engine removal or repair, remove cylinder block drain plug and air relief plug.

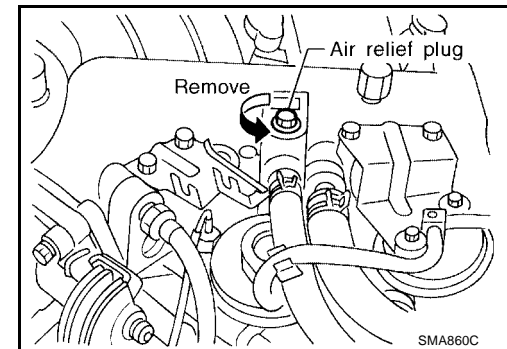
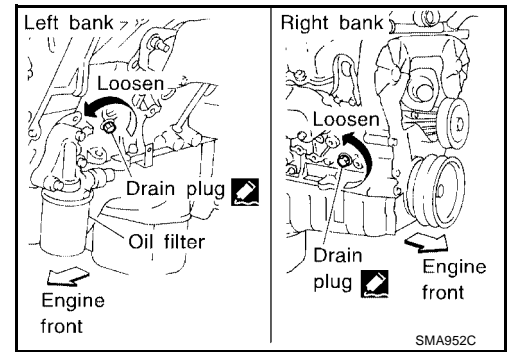

4. Check the drained coolant for contaminants such as rust, corrosion or discoloration. If the coolant is contaminated, flush the engine cooling system. Refer to [MA-28. "FLUSHING COOLING SYSTEM"](#).

REFILLING ENGINE COOLANT

1. Install the radiator drain plug. Install the reservoir tank and cylinder block drain plug, if removed for a total system drain or for engine removal or repair.
 - The radiator must be completely empty of coolant and water.
 - Apply sealant to the threads of the cylinder block drain plugs. Use Genuine High Performance Thread Sealant or equivalent. Refer to [GI-42. "RECOMMENDED CHEMICAL PRODUCTS AND SEALANTS"](#).

Radiator drain plug : 7.8 - 11.8 N·m (0.8 - 1.2 kg·m , 69 - 104 in·lb)

ENGINE MAINTENANCE (VG33E AND VG33ER)

Cylinder block drain plug : 34.3 - 44.1 N-m (3.5 - 4.5 kg-m, 25 - 33 ft-lb)
Air relief plug : 7 - 8 N-m (0.7 - 0.8 kg-m, 61 - 69 in-lb)

2. If disconnected, reattach the upper radiator hose at the engine side.
3. Set the vehicle heater controls to the full HOT and heater ON position. Turn the vehicle ignition ON with the engine OFF as necessary to activate the heater mode.
4. Install the Tool by installing the radiator cap adapter onto the radiator neck opening. Then attach the gauge body assembly with the refill tube and the venturi assembly to the radiator cap adapter.
5. Insert the refill hose into the coolant mixture container that is placed at floor level. Make sure the ball valve is in the closed position.

- Use Genuine NISSAN Long Life Anti-freeze coolant or equivalent, mixed 50/50 with distilled water or demineralized water. Refer to [MA-14, "ANTI-FREEZE COOLANT MIXTURE RATIO"](#).

Engine coolant capacity (without reservoir tank) : 10.15 ℓ (10 3/4 US qt, 8 7/8 Imp qt)

Reservoir tank : 0.8 ℓ (7/8 US qt, 3/4 Imp qt)

6. Install an air hose to the venturi assembly, the air pressure must be within specification.

Compressed air supply pressure : 5.7 - 8.5 kPa (5.6 - 8.4 kg/cm², 80 - 120 psi)

CAUTION:

The compressed air supply must be equipped with an air dryer.

7. The vacuum gauge will begin to rise and there will be an audible hissing noise. During this process open the ball valve on the refill hose slightly. Coolant will be visible rising in the refill hose. Once the refill hose is full of coolant, close the ball valve. This will purge any air trapped in the refill hose.
8. Continue to draw the vacuum until the gauge reaches 28 inches of vacuum. The gauge may not reach 28 inches in high altitude locations, refer to the vacuum specifications based on the altitude above sea level.

Altitude above sea level	Vacuum gauge reading
0 - 100 m (328 ft)	: 28 inches of vacuum
300 m (984 ft)	: 27 inches of vacuum
500 m (1,641 ft)	: 26 inches of vacuum
1,000 m (3,281 ft)	: 24 - 25 inches of vacuum

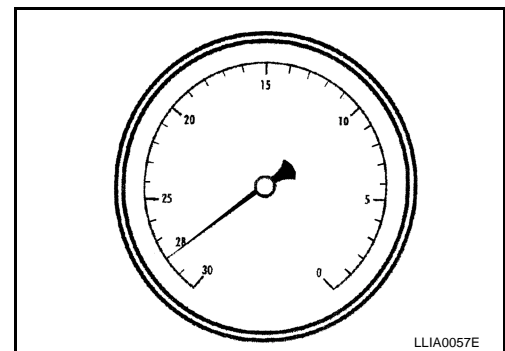
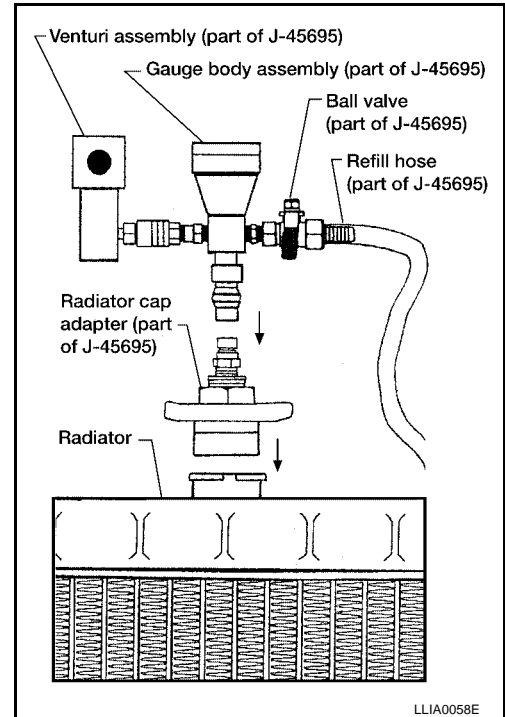

9. When the vacuum gauge has reached the specified amount, disconnect the air hose and wait 20 seconds to see if the system loses any vacuum. If the vacuum level drops, perform any necessary repairs to the system and repeat steps 6 - 8 to bring the vacuum to the specified amount. Recheck for any leaks.
10. Place the coolant container (with the refill hose inserted) at the same level as the top of the radiator. Then open the ball valve on the refill hose so the coolant will be drawn up to fill the cooling system. The cooling system is full when the vacuum gauge reads zero.

CAUTION:

Do not allow the coolant container to get too low when filling, to avoid air from being drawn into the cooling system.

11. Remove the Tool from the radiator neck opening.

ENGINE MAINTENANCE (VG33E AND VG33ER)

12. Fill the cooling system reservoir tank to the specified level. Run the engine to warm up the cooling system and top up the system as necessary before installing the radiator cap.

FLUSHING COOLING SYSTEM

1. Fill the radiator from the filler cap above the radiator upper hose and reservoir tank, with water and reinstall the filler cap above the radiator upper hose.
2. Run the engine until it reaches normal operating temperature.
3. Press the engine accelerator two or three times under no-load.
4. Stop the engine and wait until it cools down.
5. Drain the water.
6. Repeat steps 1 through 5 until clear water begins to drain from the radiator.

Checking Fuel Lines

Inspect fuel lines and tank for improper attachment, leaks, cracks, damage, loose connections, chafing or deterioration. If necessary, repair or replace faulty parts.

ELS000SJ

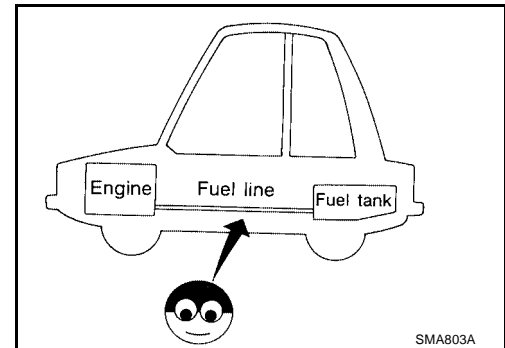

Changing Fuel Filter

ELS000SK

WARNING:

Before removing fuel filter, release fuel pressure from fuel line.

ⓘ WITH CONSULT - II

1. Start engine.
2. Perform "FUEL PRESSURE RELEASE" in "WORK SUPPORT" mode to release fuel pressure to zero.

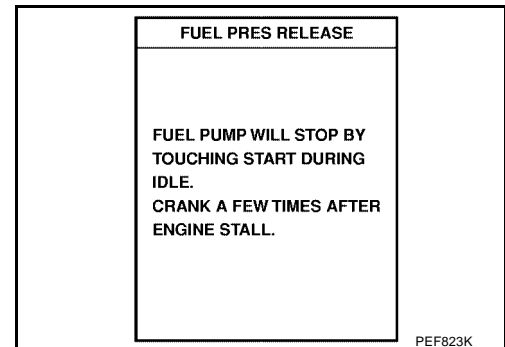

3. After engine stalls, crank engine two or three times to make sure that fuel pressure is released.
4. Turn ignition switch "OFF".
5. Remove the fuel filter shield.
6. Loosen fuel hose clamps.
7. Replace fuel filter.
 - Use a high-pressure type fuel filter. Do not use a synthetic resinous fuel filter.

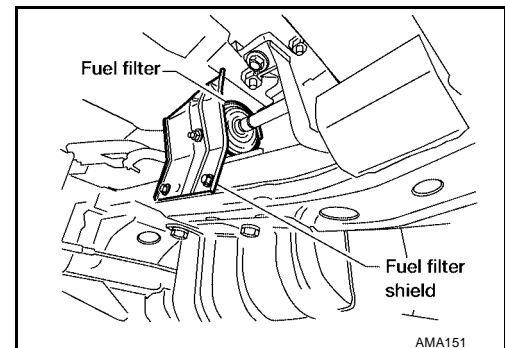

ENGINE MAINTENANCE (VG33E AND VG33ER)

8. Tighten fuel hose clamps.

Fuel hose clamps : 1.0 - 1.5 N·m (0.1 - 0.15 kg-m,
8.7 - 13.0 in-lb)

CAUTION:

Tighten high-pressure rubber hose clamp so that clamp end is 3 mm (0.12 in) from hose end.

Tightening torque specifications are the same for all rubber hose clamps.

Ensure that the screw does not contact adjacent parts.

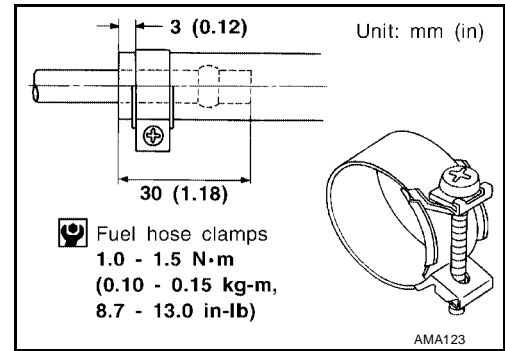

⊗ **WITHOUT CONSULT - II**

1. Remove fuel pump fuse.
For correct fuse location, refer to label on fuse block cover.
2. Start engine.
3. After engine stalls, crank engine two or three times to make sure that fuel pressure is released.
4. Turn ignition switch "OFF" and install fuel pump fuse.

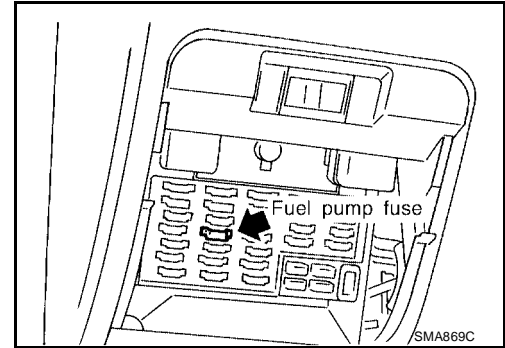

5. Remove the fuel filter shield.
6. Loosen fuel hose clamps.
7. Replace fuel filter.
 - Use a high-pressure type fuel filter. Do not use a synthetic resinous fuel filter.

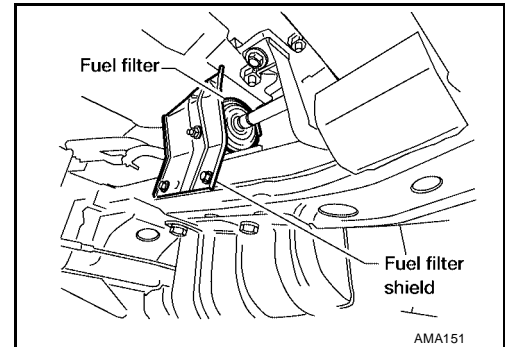

8. Tighten fuel hose clamps.

Fuel hose clamps : 1.0 - 1.5 N·m (0.1 - 0.15 kg-m,
8.7 - 13.0 in-lb)

CAUTION:

Tighten high-pressure rubber hose clamp so that clamp end is 3 mm (0.12 in) from hose end.

Tightening torque specifications are the same for all rubber hose clamps.

Ensure that the screw does not contact adjacent parts.

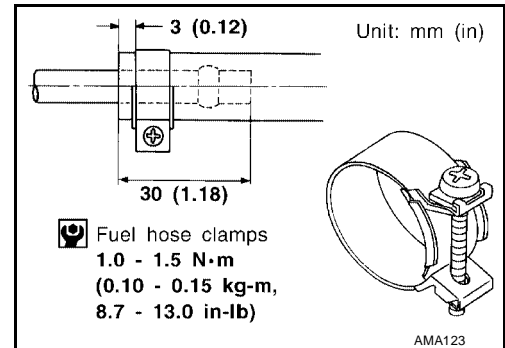

A
B
C
D
E
F
G
H
I
J
K
MA
M

ENGINE MAINTENANCE (VG33E AND VG33ER)

ELS000SL

Changing Air Cleaner Filter VISCIOUS PAPER TYPE

NOTE:

The viscous paper type filter does not need cleaning between replacement intervals.

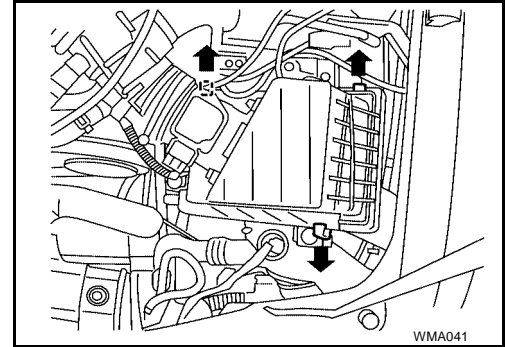

Changing Engine Oil

ELS000SM

WARNING:

- Be careful not to burn yourself, as the engine oil is hot.
 - Prolonged and repeated contact with used engine oil may cause skin cancer; try to avoid direct skin contact with used oil. If skin contact is made, wash thoroughly with soap or hand cleaner as soon as possible.
1. Warm up engine, and check for oil leakage from engine components.
 2. Stop engine and wait for more than 10 minutes.
 3. Remove drain plug and oil filler cap.
 4. Drain oil and refill with new engine oil.

Oil Specification and Viscosity

- API SG/SH and Energy Conserving I & II or API grade SJ or SL, Energy Conserving
- API Certification Mark
- ILSAC grade GF-I, GF-II & GF-III
- See [MA-12, "RECOMMENDED FLUIDS AND LUBRICANTS"](#)

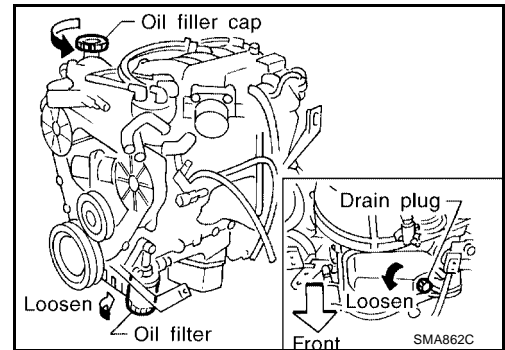

Refill Oil Capacity (Approximately)

Unit: ℓ (US qt, Imp qt)

Drain and refill	Capacity
with oil filter change	3.3 (3 1/2, 2 7/8)
without oil filter change	3.0 (3 1/8, 2 5/8)
Dry engine (engine overhaul)	3.8 (4, 3 3/8)

CAUTION:

- Be sure to clean drain plug and install with new washer.
- Oil pan drain plug : 29 - 39 N·m (3.0 - 4.0 kg·m, 22 - 29 ft·lb)**
- The refill capacity depends on the oil temperature and drain time; use the "Refill oil capacity" values as a reference and be certain to check with the dipstick when changing the oil.

ENGINE MAINTENANCE (VG33E AND VG33ER)

5. Warm up engine and check area around drain plug and oil filter for oil leakage.
6. Stop engine and wait for more than 10 minutes.
7. Check oil level.

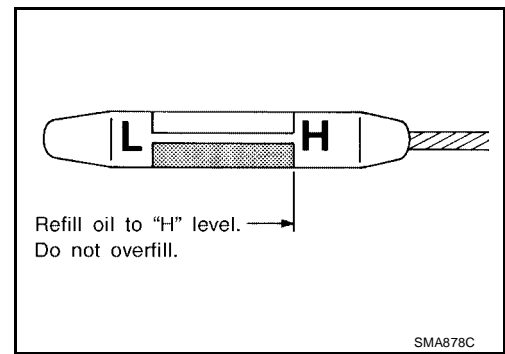

Changing Oil Filter

1. Remove oil filter with Tool.

Tool number : KV10115801 (J-38956)

WARNING:

Be careful not to burn yourself, as the engine and engine oil are hot.

The filter is a full-flow cartridge type and is provided with a relief valve.

2. Clean oil filter mounting surface on cylinder block. Coat rubber seal of new oil filter with engine oil.

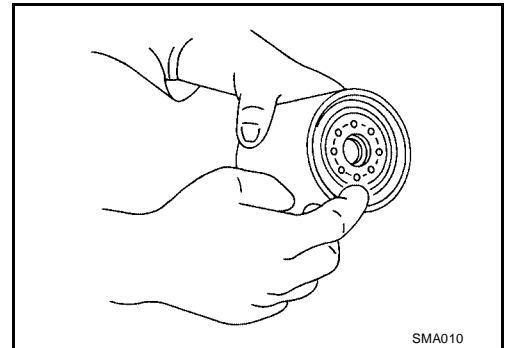

3. Screw in the oil filter until a slight resistance is felt, then tighten an additional 2/3 turn.
4. Add engine oil. Refer to [MA-30, "Changing Engine Oil"](#).
 - Clean excess oil from engine.

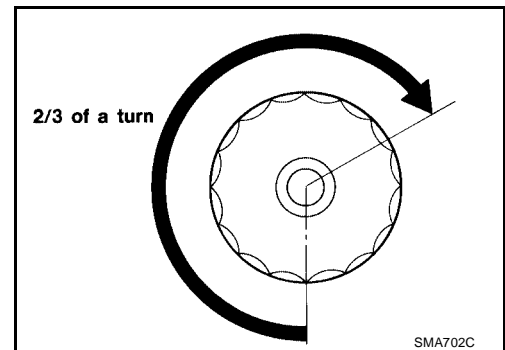

A
B
C
D
E
F
G
H
I
J
K
MA
M

ENGINE MAINTENANCE (VG33E AND VG33ER)

ELS000SO

Changing Spark Plugs

1. Disconnect ignition wires from spark plugs at boot.
Do not pull on the wire.

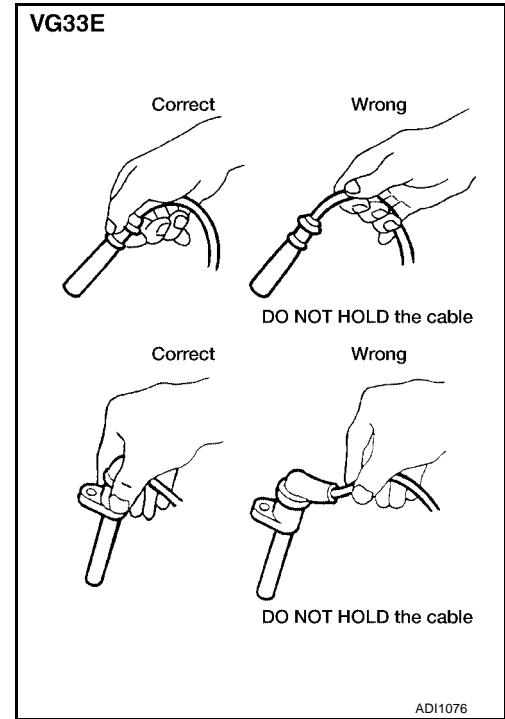

2. Remove spark plugs with 16 mm (0.63 in) spark plug wrench.
 - For VG33ER engine only; to remove the No. 2, and 4 spark plugs, the following components must be removed:
 - Disconnect the accelerator cable from the throttle body.
 - Disconnect the ASCD cable from the throttle body, if equipped.
 - Remove air inlet tube bracket from air inlet tube (with cables attached) and position aside.

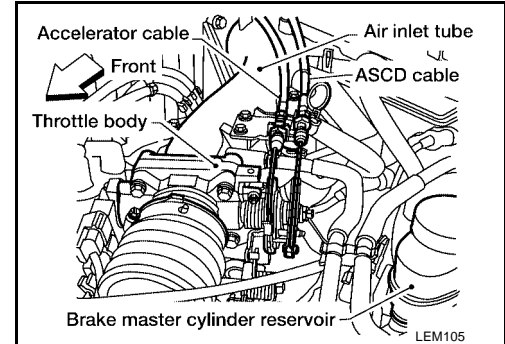

- Remove the air inlet duct.
- Disconnect the PCV hoses.
- Disconnect the resonator hose.

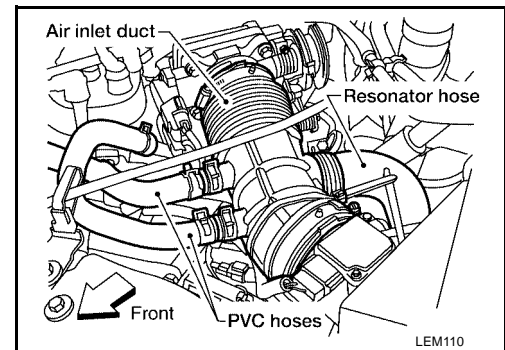

ENGINE MAINTENANCE (VG33E AND VG33ER)

- Remove the air inlet tube upper and lower supports.

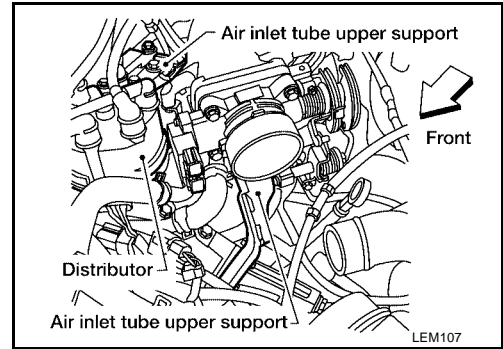

- Remove the air inlet tube bolts, nuts, and studs. Position the air inlet tube aside.
- Disconnect the evaporative emission vacuum hose.
- Disconnect the brake booster vacuum hose.
- Disconnect the TPS sensor electrical connector.
- Disconnect the TPS switch electrical connector.

3. Check type and gap of new spark plug.

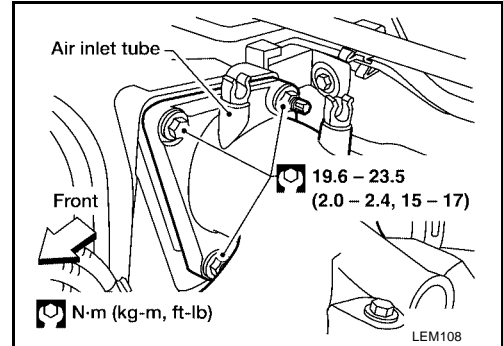

Spark Plug (VG33E)

Description	NGK (Double Platinum Tipped)
Hot type	PFR4G-11
Standard type	PFR5G-11
Cold type	PFR6G-11
Spark plug gap (nominal)	1.1 mm (0.043 in)

Spark Plug (VG33ER)

Description	NGK (Double Platinum Tipped)
Hot type	PFR5G-11
Standard type	PFR6G-11
Cold type	PFR7G-11
Spark plug gap (nominal)	1.1 mm (0.043 in)

Use standard type spark plug under normal conditions.

The hot type spark plug is suitable when fouling occurs with the standard type spark plug under conditions such as:

- frequent engine starts
- low ambient temperatures

The cold type spark plug is suitable when spark knock occurs with the standard type spark plug under conditions such as:

- extended highway driving
- frequent high engine revolution

A
B
C
D
E
F
G
H
I
J
K
MA

ENGINE MAINTENANCE (VG33E AND VG33ER)

Do not use a wire brush for cleaning.
If plug tip is covered with carbon, spark plug cleaner may be used.

Cleaner air pressure **Less than 588 kPa (6 kg/cm²
, 85 psi)**

Cleaning time **Less than 20 seconds**

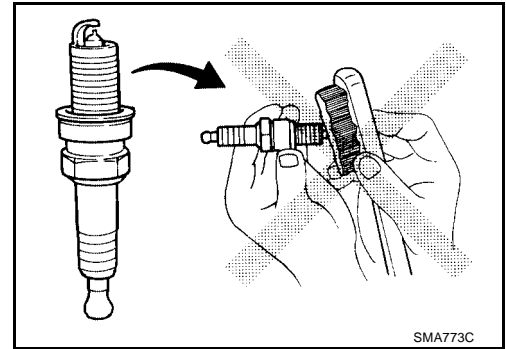

Checking and adjusting plug gap is not required between spark plug change intervals.

Spark plug gap (nominal) **1.1 mm (0.043 in)**

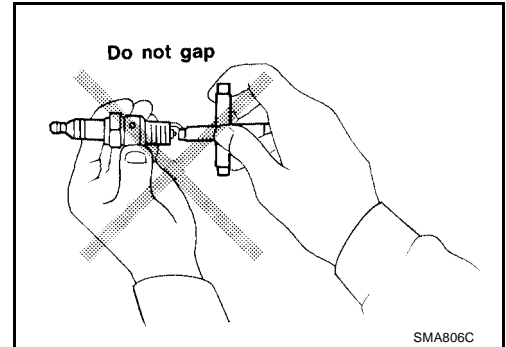

When installing spark plugs to No. 2 and 4 cylinders, securely fit each ignition wire mounting hole onto the ignition wire fixing pin.

Spark plug **: 20 - 29 N·m (2.0 - 3.0 kg·m, 14 - 22 ft·lb)**

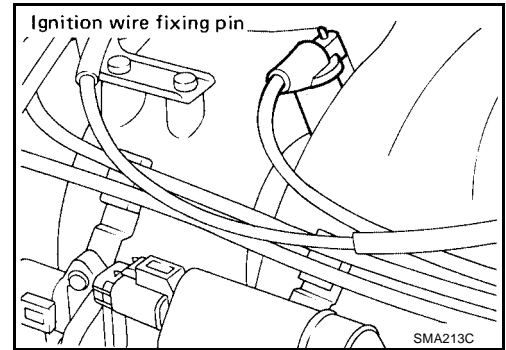

ENGINE MAINTENANCE (VG33E AND VG33ER)

ELS000SP

Checking EVAP Vapor Lines

1. Visually inspect EVAP vapor lines for improper attachment, cracks, damage, loose connections, chafing or deterioration.
2. Inspect vacuum relief valve of fuel tank filler cap for clogging, sticking, etc.

Refer to [EC-1169, "EVAPORATIVE EMISSION SYSTEM"](#) for VG33E or [EC-1744, "EVAPORATIVE EMISSION SYSTEM"](#) for VG33ER.

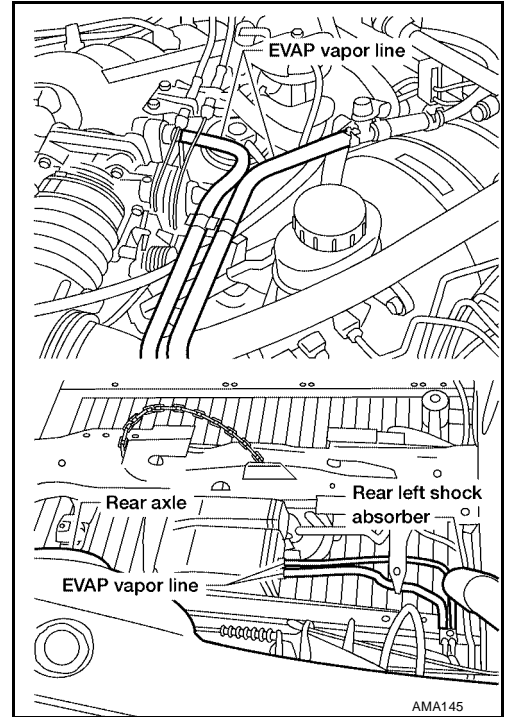

A

B

C

D

E

F

G

H

I

J

K

MA

M

CHASSIS AND BODY MAINTENANCE

PFP:00100

Changing In-cabin Microfilter

ELS000NA

To change the in-cabin microfilter, refer to [MTC-64, "Removal and Installation"](#).

Checking Exhaust System

ELS000E1

Check exhaust pipes, muffler and mounting for improper attachment, leaks, cracks, damage, loose connections, chafing or deterioration.

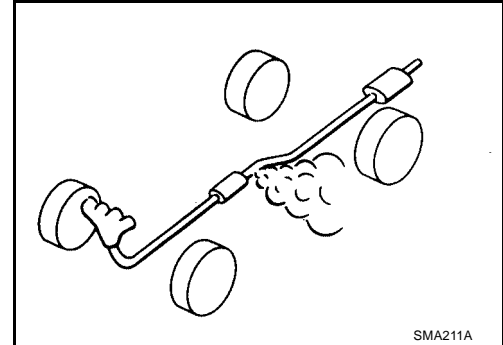

Checking Clutch Fluid Level and Leaks

ELS000E2

If fluid level is extremely low, check clutch system for leaks.

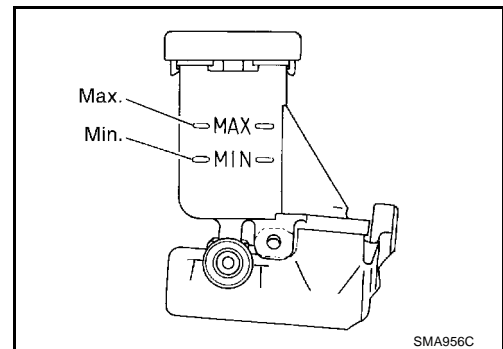

Checking M/T Oil

ELS000E3

Check for oil leakage and oil level.

CAUTION:

Never start engine while checking oil level.

- Apply sealant to filler plug threads.
- Use Genuine Anaerobic Liquid Gasket or equivalent. Refer to [GI-42, "RECOMMENDED CHEMICAL PRODUCTS AND SEALANTS"](#).

Filler plug : 25 - 34 N·m (2.5 - 3.5 kg·m, 18 - 25 ft·lb)

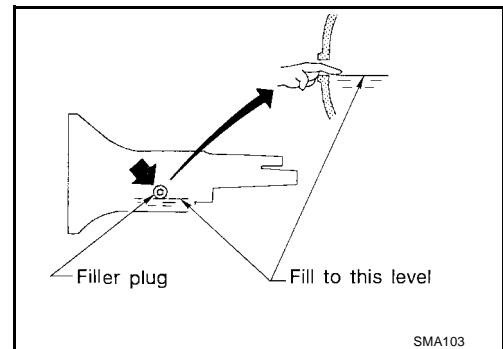

Changing M/T Oil

ELS000E4

1. Drain oil from drain plug and refill with new gear oil.
2. Check oil level.

Oil grade and viscosity : Refer to [MA-12, "RECOMMENDED FLUIDS AND LUBRICANTS"](#)

Oil capacity

FS5W71C : 2.0 l (4 1/4 US pt, 3 1/2 Imp pt)

FS5R30A

2WD : 2.8 l (5 7/8 US pt, 4 7/8 Imp pt)

4WD : 5.1 l (10 3/4 US pt, 9 Imp pt)

- Apply sealant to filler plug threads.

CHASSIS AND BODY MAINTENANCE

- Use Genuine Anaerobic Liquid Gasket or equivalent. Refer to [GI-42, "RECOMMENDED CHEMICAL PRODUCTS AND SEALANTS"](#).

Drain plug : 25 - 34 N-m (2.5 - 3.5 kg-m, 18 - 25 ft-lb)

Checking Water Entry — For 4WD Models With M/T

ELS000E5

Check water entry in the clutch housing by removing the sealing grommet, whenever driving in deep water or mud.

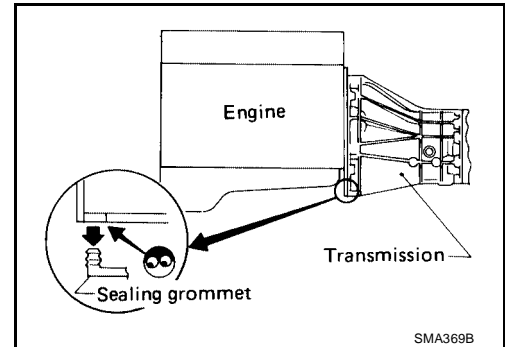

Checking A/T Fluid

ELS000E6

1. Warm up engine.
2. Check for fluid leakage.
3. Before driving, fluid level can be checked at fluid temperatures of 30 to 50°C (86 to 122°F) using "COLD" range on dipstick.
 - a. Park vehicle on level surface and set parking brake.
 - b. Start engine and move selector lever through each gear position. Leave selector lever in "P" position.
 - c. Check fluid level with engine idling.
 - d. Remove dipstick and note reading. If level is at low side of either range, and fluid to the charging pipe.
 - e. Re-insert dipstick into charging pipe as far as it will go.
 - f. Remove dipstick and note reading. If reading is at low side of range, add fluid to the charging pipe.

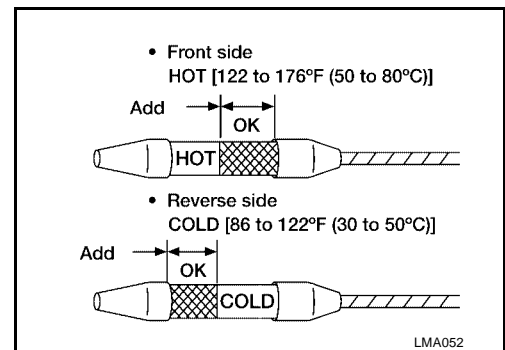

Do not overfill.

4. Drive vehicle for approximately 5 minutes in urban areas.
5. Re-check fluid level at fluid temperatures of 50 to 80°C (122 to 176°F) using "HOT" range on dipstick.
6. Check fluid condition.
 - If fluid is very dark or smells burned, refer to AT section for checking operation of A/T. Flush cooling system after repair of A/T.
 - If A/T fluid contains frictional material (clutches, bands, etc.), replace radiator and flush cooler line using cleaning solvent and compressed air after repair of A/T. Refer to [CO-14, "RADIATOR"](#) (KA24DE), [CO-30, "RADIATOR"](#) (VG33E and VG33ER).

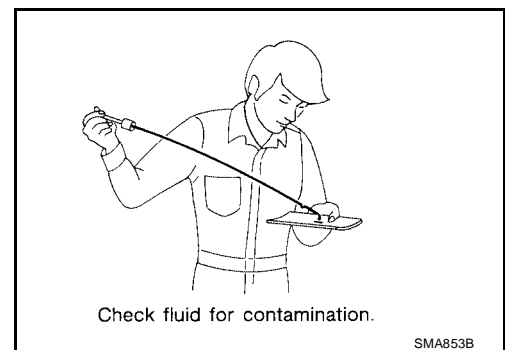

CHASSIS AND BODY MAINTENANCE

Changing A/T Fluid

ELS000E7

1. Warm up A/T fluid.
2. Stop engine.
3. Drain A/T fluid from drain plug and refill with new A/T fluid. Always refill same volume with drained fluid.

Fluid grade

Genuine NISSAN Matic "D" ATF (Continental U.S. and Alaska) or Canada NISSAN Automatic Transmission Fluid. : Refer to [MA-12, "RECOMMENDED FLUIDS AND LUBRICANTS"](#) .

Fluid capacity (with torque converter)

KA24DE : 7.9 ℓ (8 3/8 US qt, 7 Imp qt)

VG33E and VG33ER

2WD : 8.3 ℓ (8 3/4 US qt, 7 1/4 Imp qt)

4WD : 8.5 ℓ (9 US qt, 7 1/2 Imp qt)

Drain plug : 29 - 39 N·m (3.0 - 4.0 kg·m, 22 - 29 ft·lb)

4. Run engine at idle speed for five minutes.
5. Check fluid level and condition. Refer to [MA-37, "Checking A/T Fluid"](#) . If fluid is still dirty, repeat steps 2 through 5.

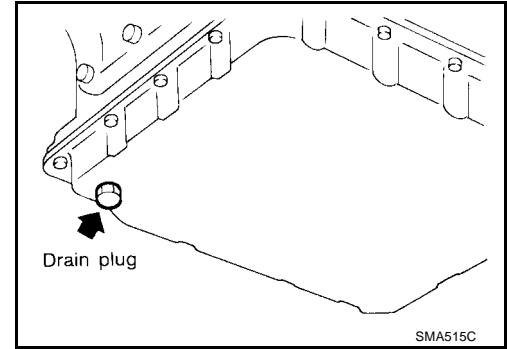

Checking Transfer Fluid

ELS000E8

Check for fluid leakage and fluid level. ATF is used for the transfer in the factory.

CAUTION:

Never start engine while checking fluid level.

- Apply sealant to filler plug threads.
- Use Genuine Anaerobic Liquid Gasket or equivalent. Refer to [GI-42, "RECOMMENDED CHEMICAL PRODUCTS AND SEALANTS"](#) .

Filler plug : 25 - 34 N·m (2.5 - 3.5 kg·m, 18 - 25 ft·lb)

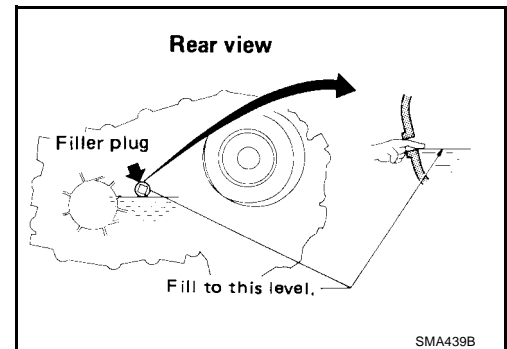

Changing Transfer Fluid

ELS000E9

When changing transfer fluid completely, ATF may be used.

Fluid grade

Genuine NISSAN Matic "D" ATF (Continental U.S. and Alaska) or Canada NISSAN Automatic Transmission Fluid or API GL-4, Viscosity SAE 75W-85 or 75W-90 : Refer to [MA-12, "RECOMMENDED FLUIDS AND LUBRICANTS"](#) .

Fluid capacity : 2.2 ℓ (2 3/8 US qt, 2 Imp qt)

- Apply sealant to drain plug threads.
- Use Genuine Anaerobic Liquid Gasket or equivalent. Refer to [GI-42, "RECOMMENDED CHEMICAL PRODUCTS AND SEALANTS"](#) .

Drain plug : 25 - 34 N·m (2.5 - 3.5 kg·m, 18 - 25 ft·lb)

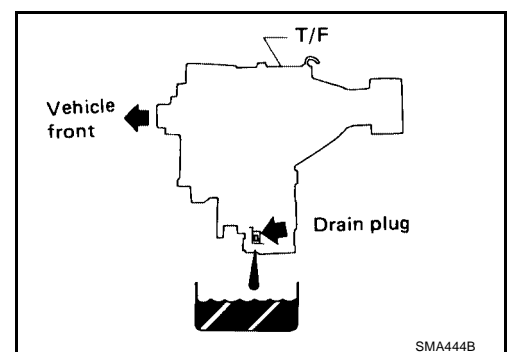

CHASSIS AND BODY MAINTENANCE

Checking Propeller Shaft

Check propeller shaft for damage, looseness or grease leakage.

ELS000EA

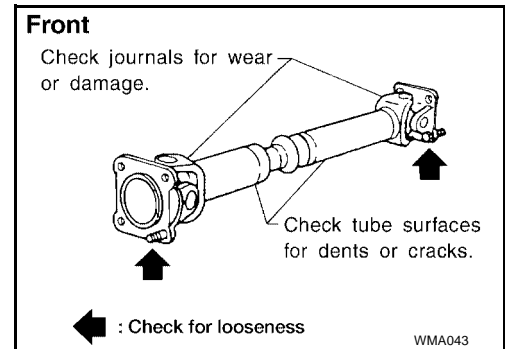
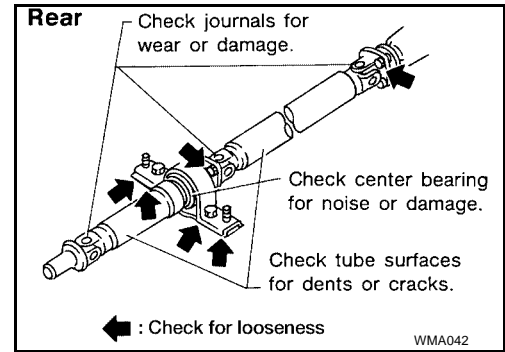

Greasing Propeller Shaft

Apply specified grease to nipples provided on propeller shaft.

Grease grade Refer to [MA-12, "RECOMMENDED FLUIDS AND LUBRICANTS"](#).

ELS000EB

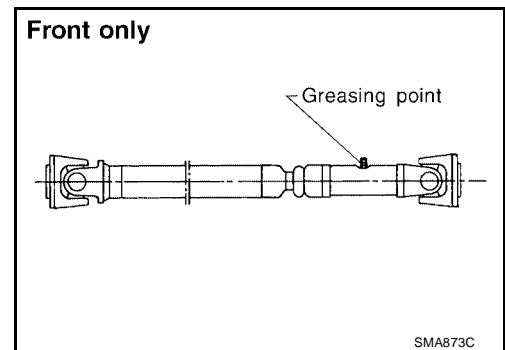

Checking Differential Gear Oil

Check for oil leakage and oil level.

Filler plug

Front — R200A : 59 - 98 N·m (6 - 10 kg·m, 43 - 72 ft·lb)

Rear

H233B : 59 - 98 N·m (6 - 10 kg·m, 43 - 72 ft·lb)

C200 : 39 - 59 N·m (4 - 6 kg·m, 29 - 43 ft·lb)

ELS000EC

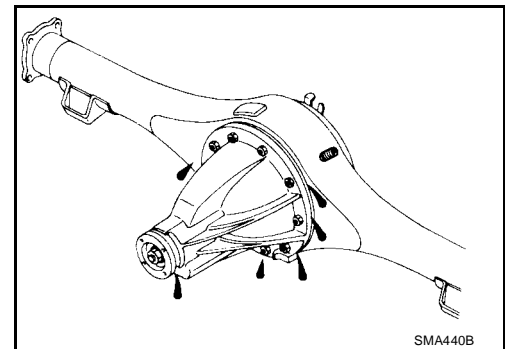

A
B
C
D
E
F
G
H
I
J
K
MA
M

CHASSIS AND BODY MAINTENANCE

ELS000ED

Changing Differential Gear Oil

1. Drain oil from drain plug and refill with new gear oil.

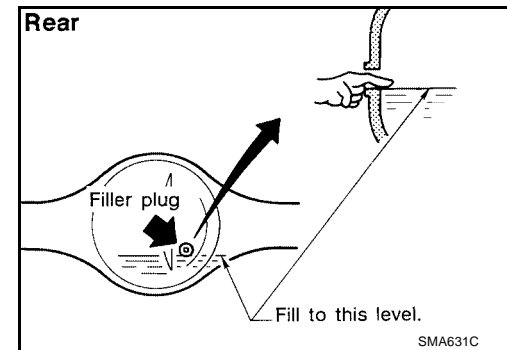
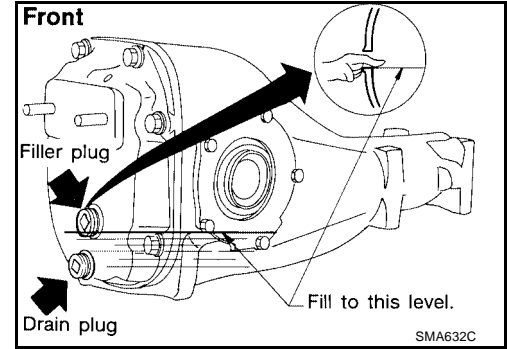

2. Check oil level.

Oil grade and viscosity : Refer to [MA-12, "RECOMMENDED FLUIDS AND LUBRICANTS"](#) .

Oil capacity

Front — R200A : 1.75 ℓ (3 3/4 US pt, 3 1/8 Imp pt)

Rear

H233B : 2.8 ℓ (5 7/8 US pt, 4 7/8 Imp pt)

C200 : 1.3 ℓ (2 3/4 US pt, 2 1/4 Imp pt)

- Apply sealant to plug threads.
- Use Genuine Anaerobic Liquid Gasket or equivalent. Refer to [GI-42, "RECOMMENDED CHEMICAL PRODUCTS AND SEALANTS"](#) .

Filler plug

Front — R200A : 59 - 98 N·m (6 - 10 kg·m, 43 - 72 ft·lb)

Rear

H233B : 59 - 98 N·m (6 - 10 kg·m, 43 - 72 ft·lb)

C200 : 39 - 59 N·m (4 - 6 kg·m, 29 - 43 ft·lb)

Drain plug

Front — R200A : 59 - 98 N·m (6 - 10 kg·m, 43 - 72 ft·lb)

Rear

H233B : 59 - 98 N·m (6 - 10 kg·m, 43 - 72 ft·lb)

C200 : 59 - 98 N·m (6 - 10 kg·m, 43 - 72 ft·lb)

LIMITED-SLIP DIFFERENTIAL GEAR

- Use only approved limited-slip differential gear oil. Refer to [MA-12, "RECOMMENDED FLUIDS AND LUBRICANTS"](#) .
 - Limited-slip differential identification.
1. Lift both rear wheels off the ground.

CHASSIS AND BODY MAINTENANCE

2. Turn one rear wheel by hand.
3. If both rear wheels turn in the same direction simultaneously, vehicle is equipped with limited-slip differential.

Balancing Wheels

ELS000EE

Adjust wheel balance using the road wheel center.

Wheel balance (maximum allowable unbalance) : Refer to [MA-47, "Wheel Balance"](#)

Tire Rotation

ELS000EF

- After rotating the tires, adjust the tire pressure.
- Retighten the wheel nuts when the vehicle has been driven for 1,000 km (600 miles) (also in cases of a flat tire, etc.).

Wheel nuts : 98 - 117 N·m (10 - 12 kg·m, 73 - 86 ft·lb)

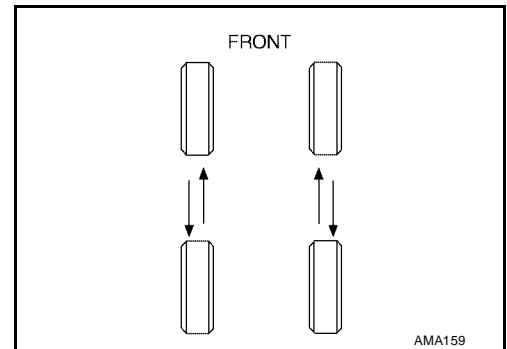

Checking Brake Fluid Level and Leaks

ELS000EG

- Check fluid level in reservoir tank. It should be between MAX and MIN lines on reservoir tank.
- If fluid level is extremely low, check brake system.
- If the brake warning lamp comes on, check brake fluid level switch and parking brake switch.

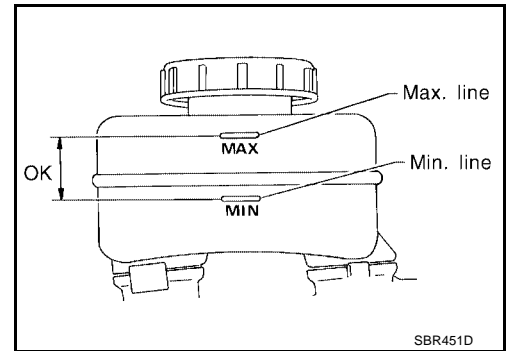

Checking Brake Lines and Cables

ELS000EH

CAUTION:

If leakage occurs around joints, retighten or, if necessary, replace damaged parts.

1. Check brake lines (tubes and hoses) for cracks, deterioration and other damage. Replace any damaged parts.
2. Check for oil leakage by fully depressing brake pedal while engine is running.

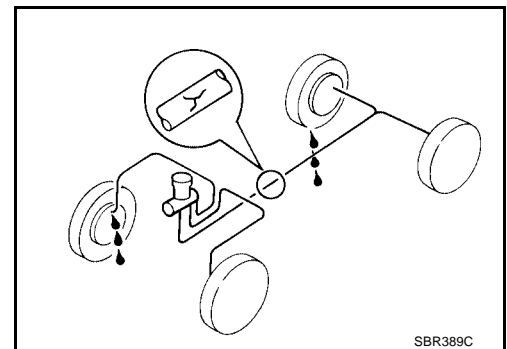

CHASSIS AND BODY MAINTENANCE

Checking Disc Brake ROTOR

ELS000E1

Check condition, wear and damage.

Standard thickness

KA24DE : 26 mm (1.024 in)

VG33E & VG33ER : 28 mm (1.10 in)

Minimum thickness

KA24DE : 24 mm (0.945 in)

VG33E & VG33ER : 26 mm (1.024 in)

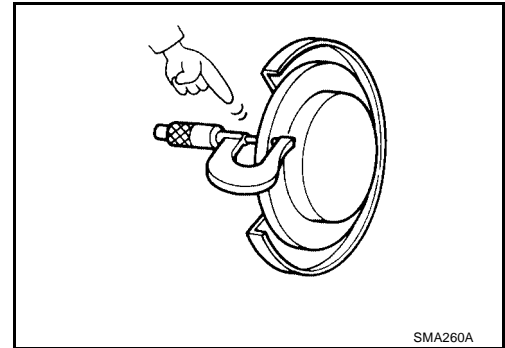

CALIPER

Check for leakage.

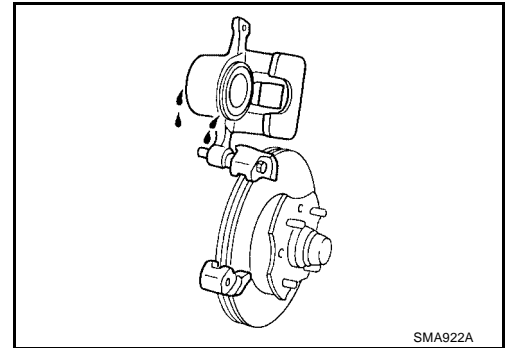

PAD

Check wear or damage.

Standard thickness : 10 mm (0.39 in)

Minimum thickness : 2.0 mm (0.079 in)

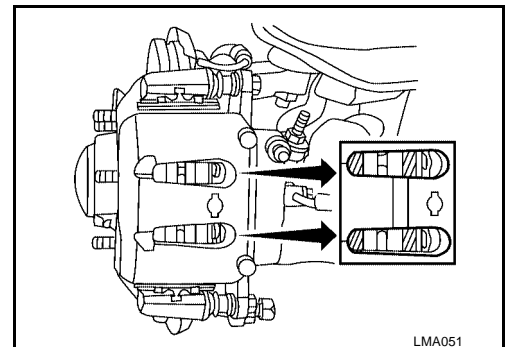

Checking Drum Brake WHEEL CYLINDER

ELS000EJ

Check for leakage.

DRUM

Check condition and inner surface.

Standard inner diameter

KA24DE : 260.0 mm (10.23 in)

VG33E & VG33ER : 295.0 mm (11.61 in)

Drum repair limit (inner diameter)

KA24DE : 261.5 mm (10.30 in)

VG33E & VG33ER : 296.5 mm (11.67 in)

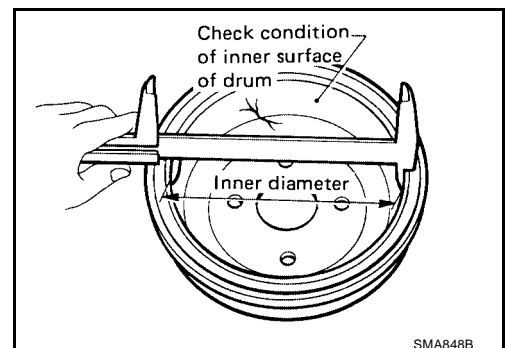

CHASSIS AND BODY MAINTENANCE

LINING

Check wear or damage.

Standard thickness

KA24DE : 5.5 mm (0.217 in)

VG33E & VG33ER : 6.1 mm (0.240 in)

Minimum thickness

Lining wear limit : 1.5 mm (0.059 in)

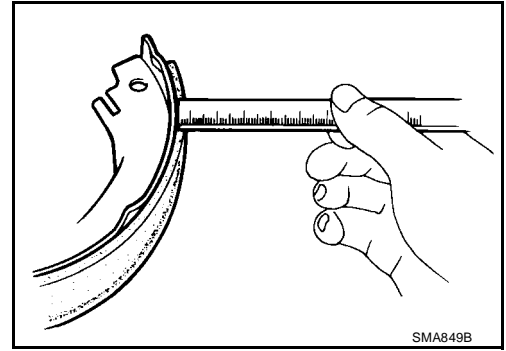

Checking Steering Gear and Linkage

STEERING GEAR

- Check steering gear housing for looseness, damage and oil leakage.
- Check connection with steering column for looseness.

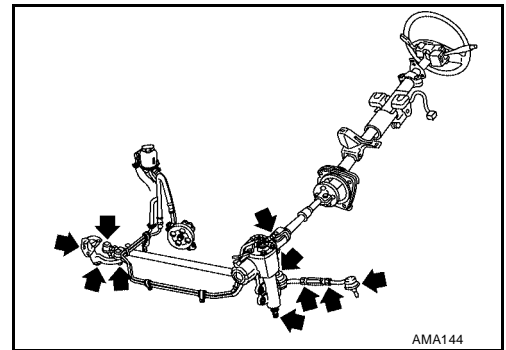

STEERING LINKAGE

- Check ball joint, dust cover and other component parts for looseness, wear, damage and grease leakage.

Checking Power Steering Fluid and Lines

CHECKING FLUID LEVEL

- Check fluid level with engine off.
- Check fluid level on reservoir. Use "HOT" range at fluid temperatures of 50° to 80°C (122° to 176°F). Use "COLD" range at fluid temperatures of 0° to 30°C (32° to 86°F).

CAUTION:

- Do not overfill.
- Recommended fluid is Genuine NISSAN PSF, Canada NISSAN Automatic Transmission Fluid, DEXRON™ III, MERCON™ or equivalent ATF may also be used. Refer to [MA-12, "RECOMMENDED FLUIDS AND LUBRICANTS"](#).

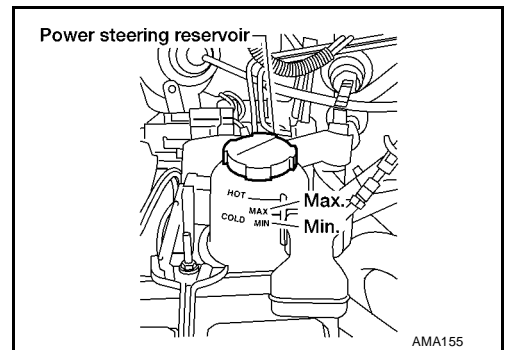

CHECKING LINES

- Check lines for improper attachment, leaks, cracks, damage, loose connections, chafing and deterioration.

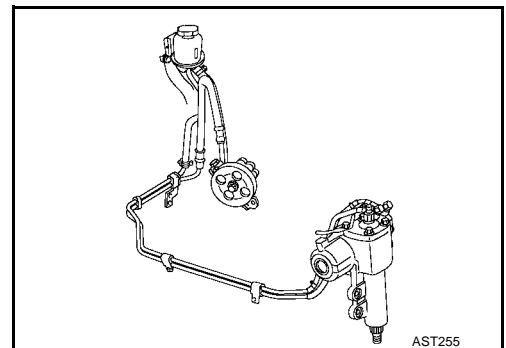

A
B
C
D
E
F
G
H
I
J
K
MA
M

CHASSIS AND BODY MAINTENANCE

ELS000EM

Checking Axle and Suspension Parts FRONT AND REAR AXLE AND SUSPENSION PARTS

Check front and rear axle and suspension parts for excessive play, cracks, wear or other damage.

- Shake each wheel to check for excessive play.
- Rotate each wheel to check for abnormal noise.
- Check axle and suspension nuts and bolts for looseness.

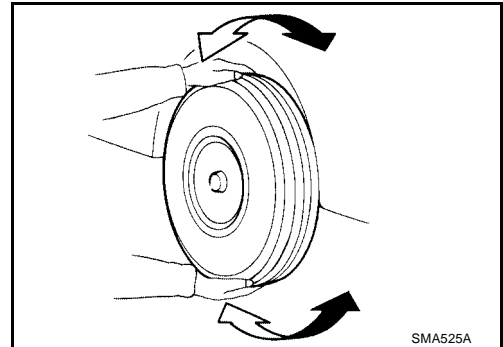

- Check strut (shock absorber) for oil leakage or other damage.
- Check suspension ball joint for grease leakage and ball joint dust cover for cracks or other damage.

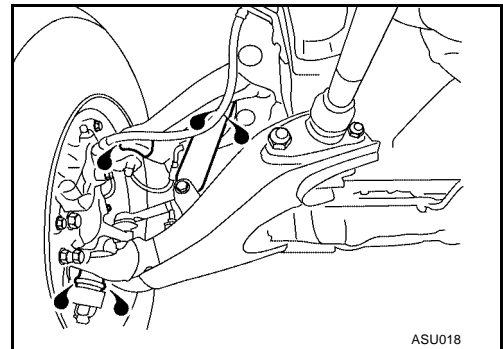

DRIVE SHAFT

Check boot and drive shaft for cracks, wear, damage, and grease leakage.

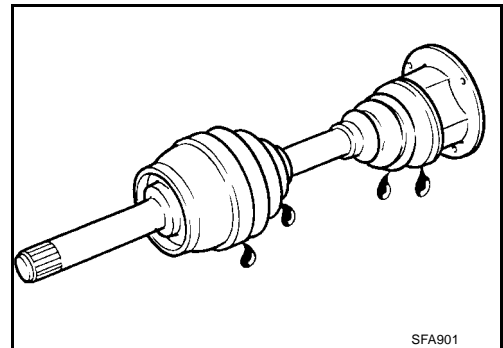

CHASSIS AND BODY MAINTENANCE

Lubricating Locks, Hinges and Hood Latches

ELS000EN

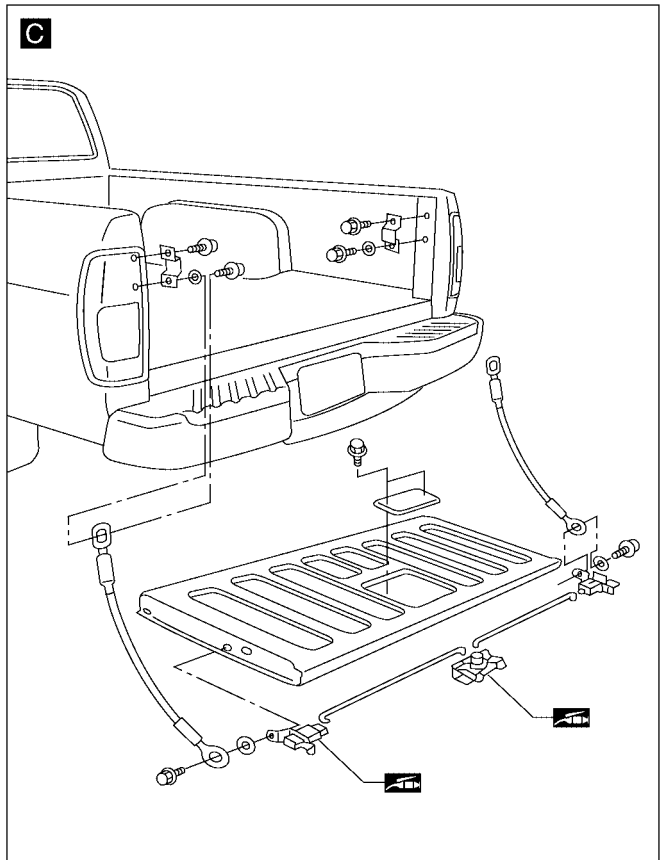
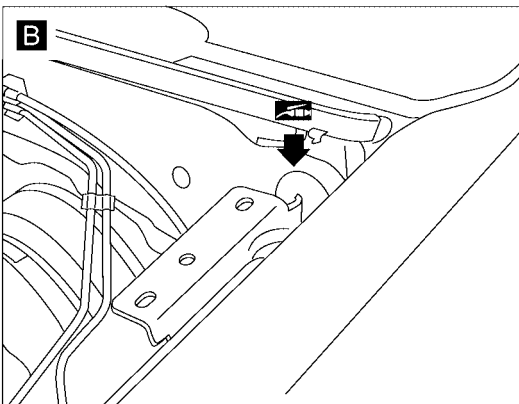
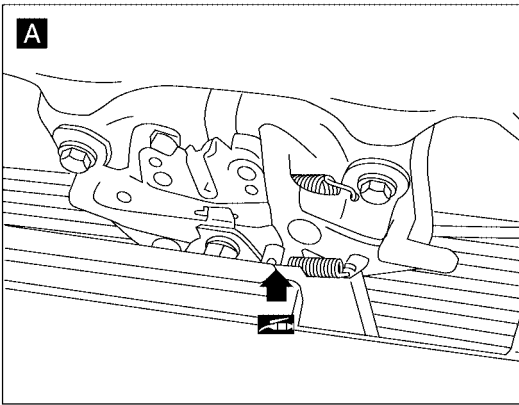
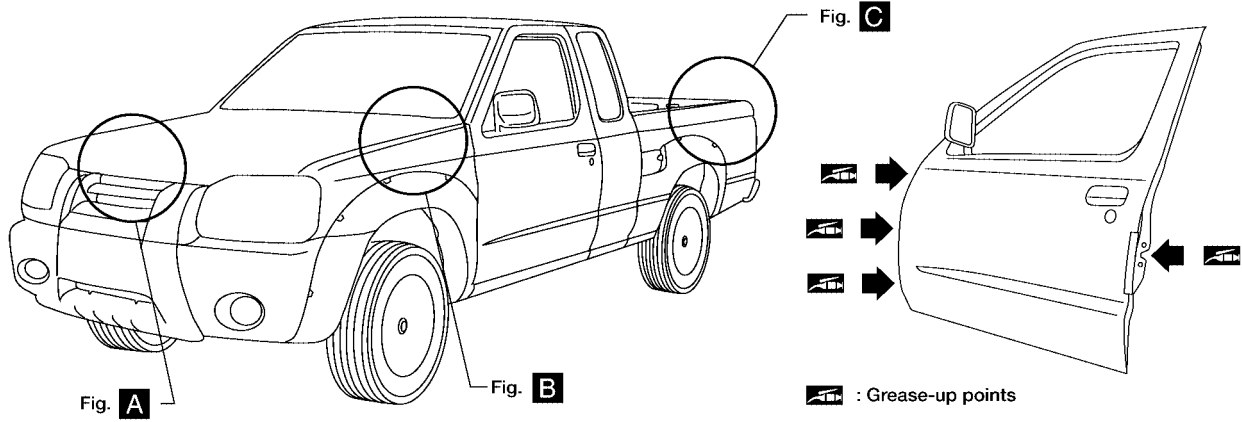

Lubricate the locations shown. Refer to [MA-12, "RECOMMENDED FLUIDS AND LUBRICANTS"](#) .

WLIA0002E

A
B
C
D
E
F
G
H
I
J
K
MA
M

CHASSIS AND BODY MAINTENANCE

Checking Seat Belts, Buckles, Retractors, Anchors and Adjusters

ELS000EO

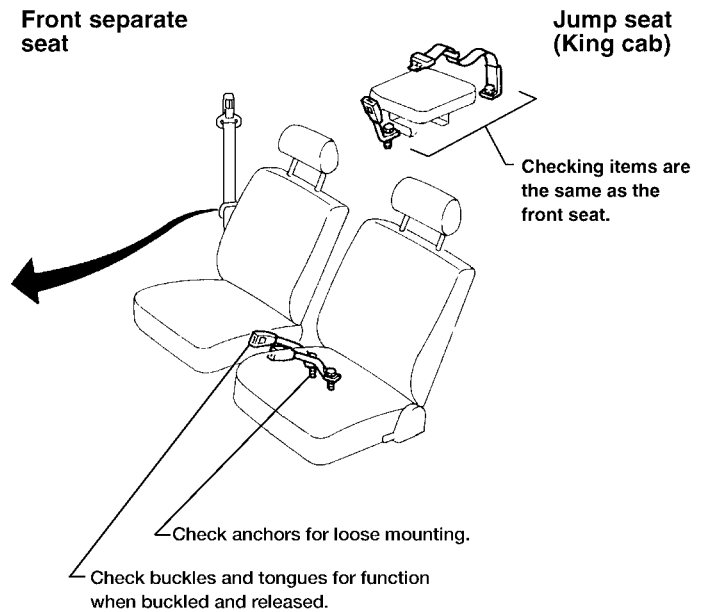
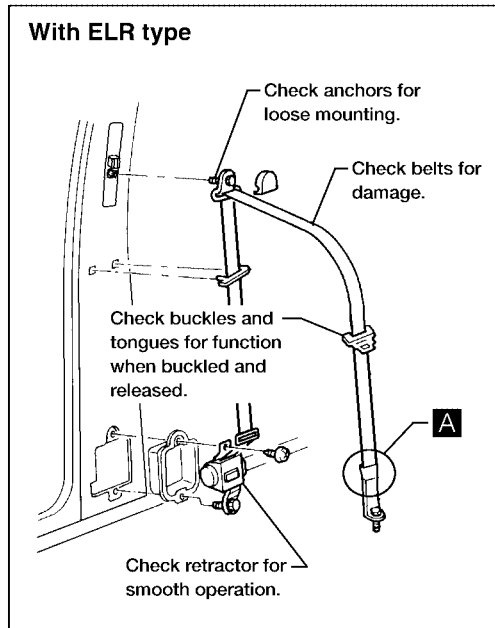

For details, refer to "Seat Belt Inspection", "SEAT BELTS" in SB section.

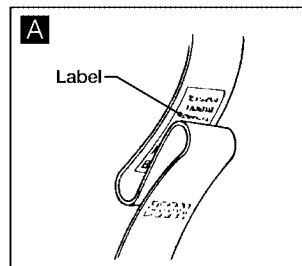

For front seat belt, shock absorber type belt has been used. Replace the belt when loop has been pulled out and "REPLACE BELT" is visible because this seat belt has a loop of webbing under the sleeve.

CAUTION:

1. If the vehicle has collided or overturned, replace the entire belt assembly, regardless of nature of accident.
2. If the condition of any component of a seat belt is questionable, do not repair seat belt, but replace it as a belt assembly.
3. If webbing is cut, frayed, or damaged, replace belt assembly.
4. Do not spill drinks, oil, etc. on inner lap belt buckle. Never oil tongue and buckle.
5. Use a NISSAN genuine seat belt assembly.

WLIA0003E

CHASSIS AND BODY MAINTENANCE

Wheel Balance

ELS000ET

Maximum allowable unbalance	Dynamic (At rim flange)	10 g (0.35 oz) (one side)
	Static	20 g (0.71 oz)

A

B

C

D

E

F

G

H

I

J

K

MA

M

CHASSIS AND BODY MAINTENANCE
