

# ACCELERATOR CONTROL, FUEL & EXHAUST SYSTEMS

## SECTION FE

GI

MA

EM

LC

EC

**FE**

## CONTENTS

<b>PREPARATION</b> .....	2	<b>FUEL SYSTEM</b> .....	4	CL
Special Service Tool .....	2	Removal and Installation .....	4	
Commercial Service Tool .....	2	FUEL TANK .....	5	MT
<b>ACCELERATOR CONTROL SYSTEM</b> .....	3	FUEL PUMP AND FUEL LEVEL SENSOR .....	7	
Removal and Installation .....	3	<b>EXHAUST SYSTEM</b> .....	8	AT
Adjusting Accelerator Wire .....	3	Removal and Installation .....	8	

TF

PD

AX

SU

BR

ST

RS

BT

HA

SC

EL

IDX

# PREPARATION

Special Service Tool

## Special Service Tool

NEFE0001

The actual shapes of Kent-Moore tools may differ from those of special service tools illustrated here.

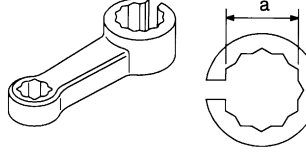
Tool number (Kent-Moore No.) Tool name	Description
KV10114400 (J38365) Heated oxygen sensor wrench	 <p data-bbox="1031 352 1446 432">Loosening or tightening rear heated oxygen sensor <b>a: 22 mm (0.87 in)</b></p> <p data-bbox="418 527 480 548">NT636</p>

## Commercial Service Tool

NEFE0007

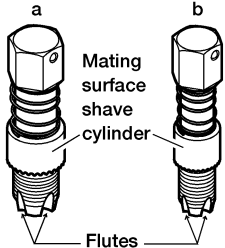
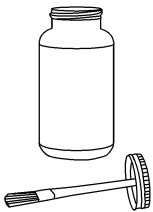
Tool name (Kent-Moore No.)	Description
Oxygen sensor thread cleaner (J-43897-18) (J-43897-12)	 <p data-bbox="1036 1045 1468 1262">Reconditioning the exhaust system threads before installing a new oxygen sensor. Use with anti-seize lubricant shown in Commercial Service Tools. <b>a: J-43897-18 18 mm diameter, for Zirconia Oxygen Sensor</b> <b>b: J-43897-12 12 mm diameter, for Titania Oxygen Sensor</b></p> <p data-bbox="430 1318 508 1339">AEM488</p>
Anti-seize lubricant (Permatex <sup>®</sup> 133AR or equivalent meeting MIL specification MIL-A-907)	 <p data-bbox="1036 1360 1471 1436">Lubricating oxygen sensor thread cleaning tool when reconditioning exhaust system threads.</p> <p data-bbox="430 1633 508 1654">AEM489</p>

# ACCELERATOR CONTROL SYSTEM

Removal and Installation

## Removal and Installation

NEFE0002

### CAUTION:

- When removing accelerator wire, make a mark to indicate lock nut's initial position.
- Check that throttle valve opens fully when accelerator pedal is fully depressed. Also check that it returns to idle position when pedal is released.
- Check accelerator control parts for improper contact with any adjacent parts.
- When connecting accelerator wire, be careful not to twist or scratch its inner wire.
- Refer to *EL-165*, "ASCD Wire Adjustment".

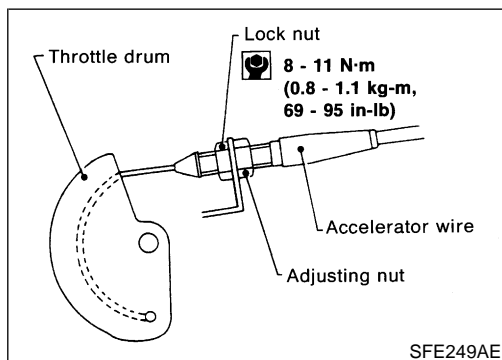
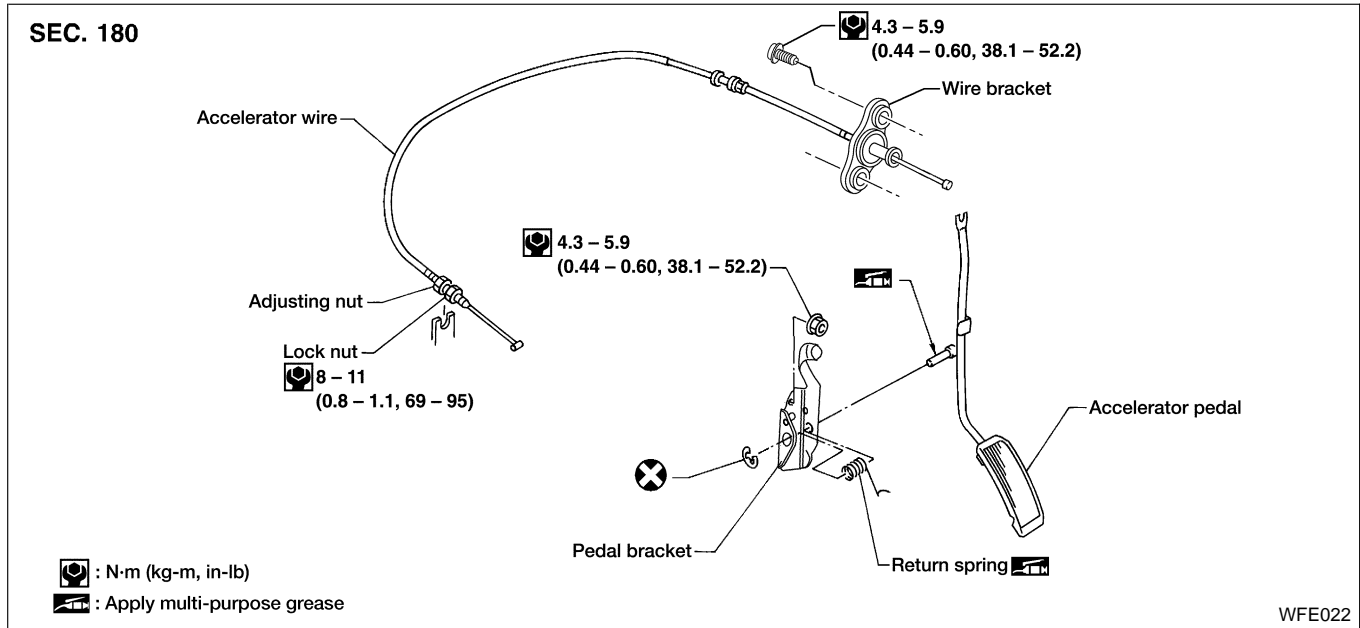

### Adjusting Accelerator Wire

NEFE0003

#### NOTE:

Adjust accelerator wire with the engine warmed up to normal operating temperature and ignition switch turned to OFF.

1. Loosen lock nut and tighten accelerator adjusting nut until throttle drum starts to move.
2. From that position, turn back adjusting nut 1.5 to 2 turns, and secure lock nut.

GI  
MA  
EM  
LC  
EC  
FE  
CL  
MT  
AT  
TF  
PD  
AX  
SU  
BR  
ST  
RS  
BT  
HA  
SC  
EL  
IDX

## Removal and Installation

NEFE0004

### **WARNING:**

When replacing fuel line parts, be sure to observe the following:

- Put a “CAUTION: INFLAMMABLE” sign in workshop.
- Do not smoke while servicing fuel system. Keep open flames and sparks away from work area.
- Be sure to furnish the workshop with a CO<sub>2</sub> fire extinguisher.

### **CAUTION:**

- Before removing fuel line parts, carry out the following procedures:
  - a) Put drained fuel in an explosion-proof container and put lid on securely.
  - b) Release fuel pressure from fuel line. Refer to *EC-57* (KA24DE), *EC-658* (VG33E), *EC-1259* (VG33ER), “Fuel Pressure Release”.
  - c) Disconnect battery ground cable.
    - Remove quick connectors with commercial service tool.
    - Always replace O-ring with a new one.
    - Do not kink or twist hoses and tubes when installed.
    - Do not tighten hose clamps excessively to avoid damaging hoses.
    - Perform an inspection and installation of EVAP system parts as necessary. Refer to *EC-40* (KA24DE), *EC-640* (VG33E), *EC-1241* (VG33ER), “Evaporative Emission System”.
    - For inspection and installation of ORVR system parts, refer to *EC-45* (KA24DE), *EC-646* (VG33E), *EC-1247* (VG33ER), “On-Board Refueling Vapor Recovery (ORVR)”.
    - After installation, run engine and check for fuel leaks at connections.
    - Use only a genuine NISSAN fuel filler cap as a replacement. If an incorrect fuel filler cap is used, the MIL may come on.

# FUEL SYSTEM

Removal and Installation (Cont'd)

## SEC. 172

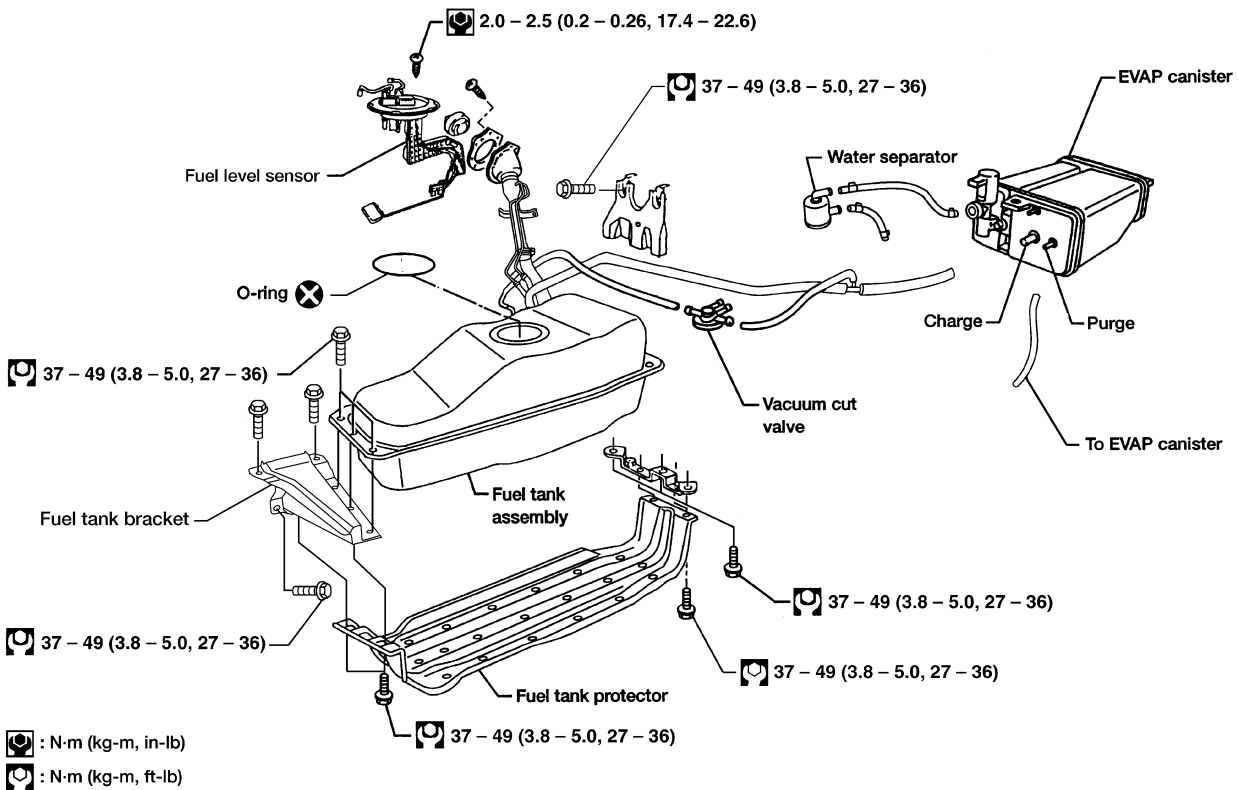

WFE031

## FUEL TANK

NEFE0004S01

1. Release fuel pressure from fuel line. Refer to **EC-57**(KA24DE), **EC-658**(VG33E), **EC-1259**(VG33ER), "Fuel Pressure Release".
2. Disconnect battery ground cable.
3. Drain fuel from fuel tank.
4. Disconnect electrical connectors.
5. Remove filler protector.

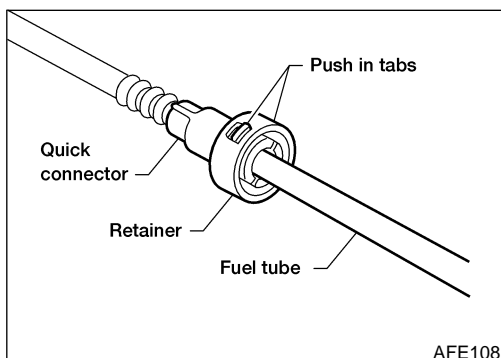

AFE108

6. Remove the quick connectors as follows:
  - 1) Put mating marks on the connectors for correct installation.
  - 2) Hold the sides of the connector, push in tabs, and pull out the tube inserted in the retainer.

### CAUTION:

- The tube can be removed when the push in tabs are completely depressed.
- Do not use any tools to remove the quick connector.
- Keep the connecting portion of the tubes and quick connector clean.

GI  
MA  
EM  
LC  
EC  
FE  
CL  
MT  
AT  
TF  
PD  
AX  
SU  
BR  
ST  
RS  
BT  
HA  
SC  
EL  
IDX

# FUEL SYSTEM

## Removal and Installation (Cont'd)

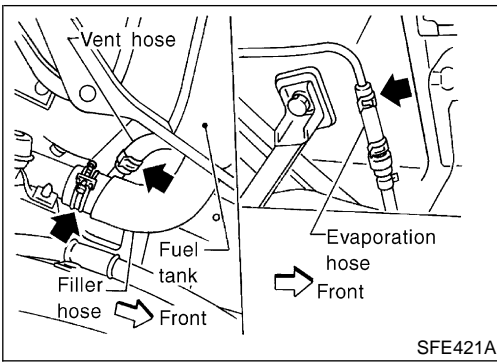

7. Disconnect filler hose, vent and evaporation hose at fuel tank side.

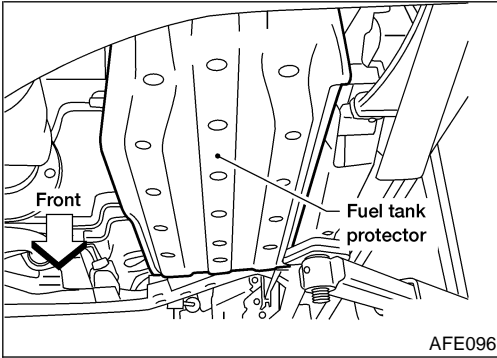

8. Remove fuel tank protector.

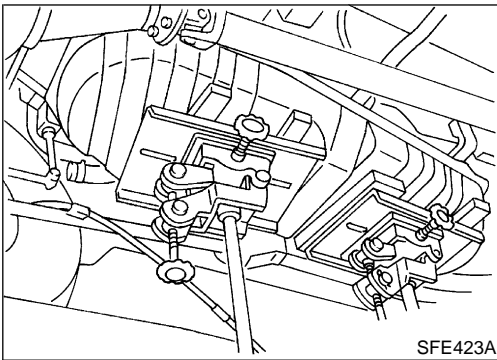

9. Remove fuel tank mounting bolts while supporting fuel tank.

10. Remove fuel tank.

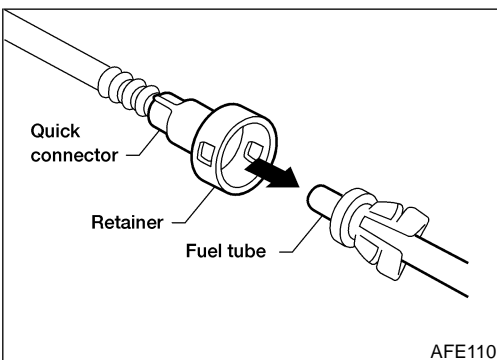

To install, reverse the removal procedure. Connect the quick connectors as follows.

- Make sure the connectors are clean and undamaged.
- Align push in tabs with retainer openings.
- Insert tube into the center of the connector until you hear a click.

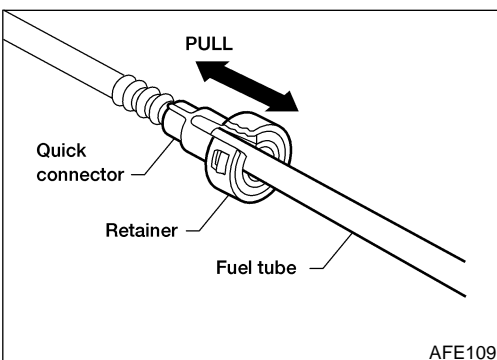

After connecting quick connectors, make sure the connection is fully seated and locked in place as follows:

- Pull on the fuel tube and connector to make sure they are properly connected.
- Start the engine, increase engine speed and verify that there are no leaks.

# FUEL SYSTEM

Removal and Installation (Cont'd)

## FUEL PUMP AND FUEL LEVEL SENSOR

NEFE0004S02

SEC. 172

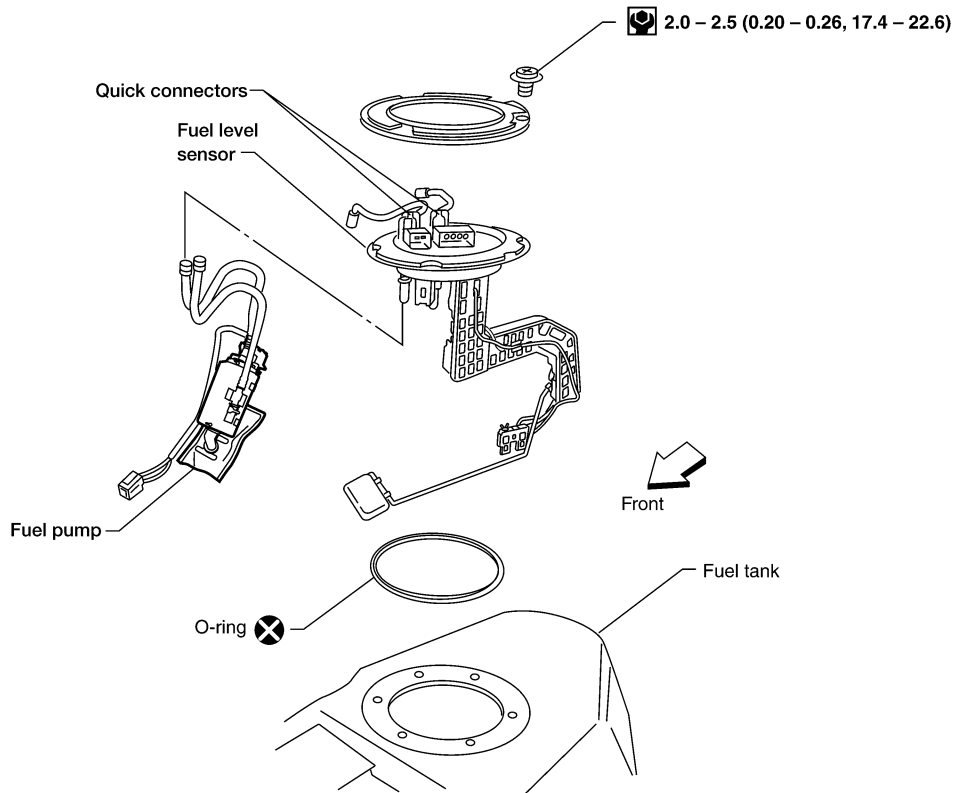

: N·m (kg-m, in-lb)

WFE024

GI

MA

EM

LC

EC

FE

CL

MT

AT

TF

PD

AX

SU

BR

ST

RS

BT

HA

SC

EL

IDX

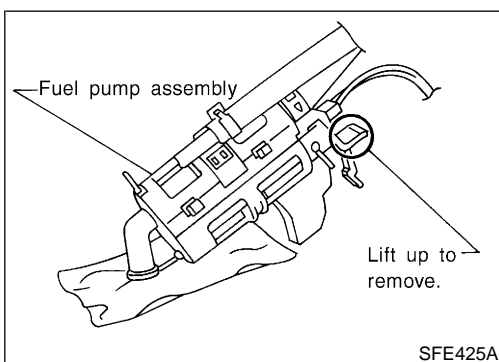

SFE425A

1. Remove fuel tank. Refer to "FUEL TANK", FE-5.
  - For removal of quick connectors, refer to step 6 of "FUEL TANK", FE-5.
2. Remove the six screws.
3. Remove fuel level sensor retainer and fuel level sensor.
4. Remove fuel pump with bracket while lifting the pawl of the fuel pump bracket upward.

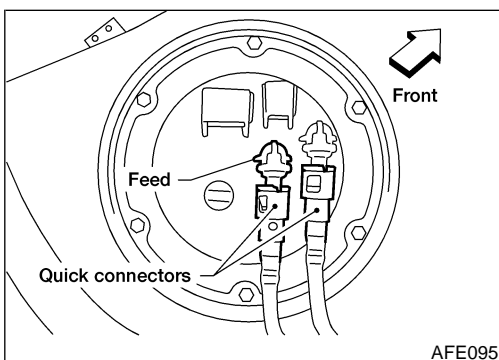

AFE095

5. Remove fuel level sensor assembly. Installation procedure is the reverse order of removal.

- Install fuel level sensor as shown.

**CAUTION:**

- **Tighten bolts to specified torque.**
  - : 2.0 - 2.5 N·m (0.20 - 0.26 kg-m, 17.4 - 22.6 in-lb)
- Always replace O-ring with a new one.
- Make sure the connectors are clean and undamaged.
- After installation, run engine and check for leaks at connections.

# EXHAUST SYSTEM

Removal and Installation

---

## Removal and Installation

NEFE0005

### **CAUTION:**

- Always replace exhaust gaskets with new ones when reassembling.
- With engine running, check all tube connections for exhaust gas leaks, and entire system for unusual noises.
- Check to ensure that mounting brackets and mounting insulators are installed properly and free from undue stress. Improper installation could result in excessive noise or vibration.
- Discard any heated oxygen sensor which has been dropped from a height of more than 0.5 m (19.7 in) onto a hard surface such as a concrete floor; use a new one.
- Before installing new oxygen sensor, clean exhaust system threads using Oxygen Sensor Thread Cleaner tool J-43897-18 or J-43897-12 and approved anti-seize lubricant.
- Do not over-torque the oxygen sensor. Doing so may cause damage to the oxygen sensor, resulting in the MIL coming on.



# EXHAUST SYSTEM

Removal and Installation (Cont'd)

KA24DE Models

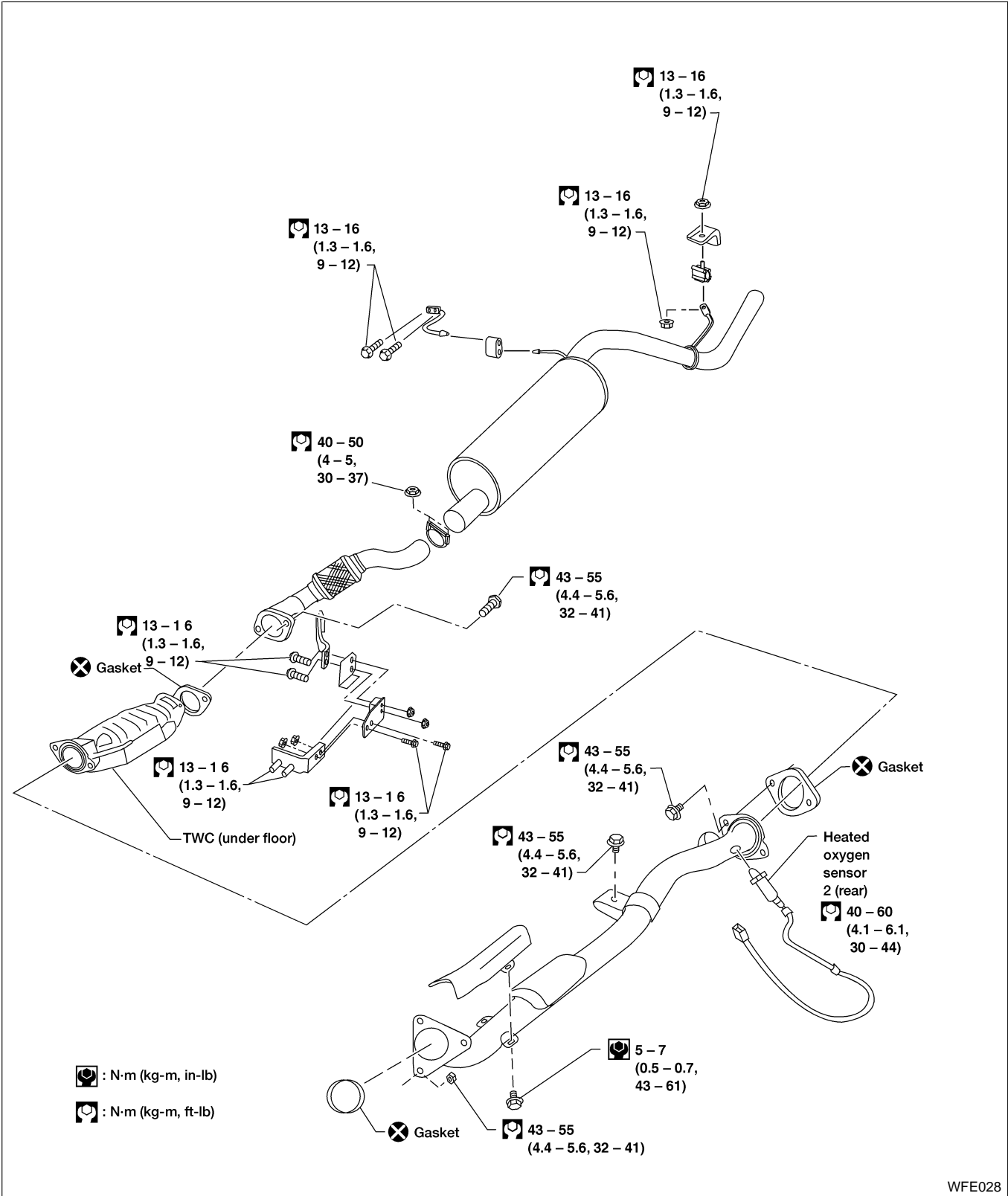

GI  
MA  
EM  
LC  
EC  
FE  
CL  
MT  
AT  
TF  
PD  
AX  
SU  
BR  
ST  
RS  
BT  
HA  
SC  
EL  
IDX

# EXHAUST SYSTEM

Removal and Installation (Cont'd)

## VG33E Models

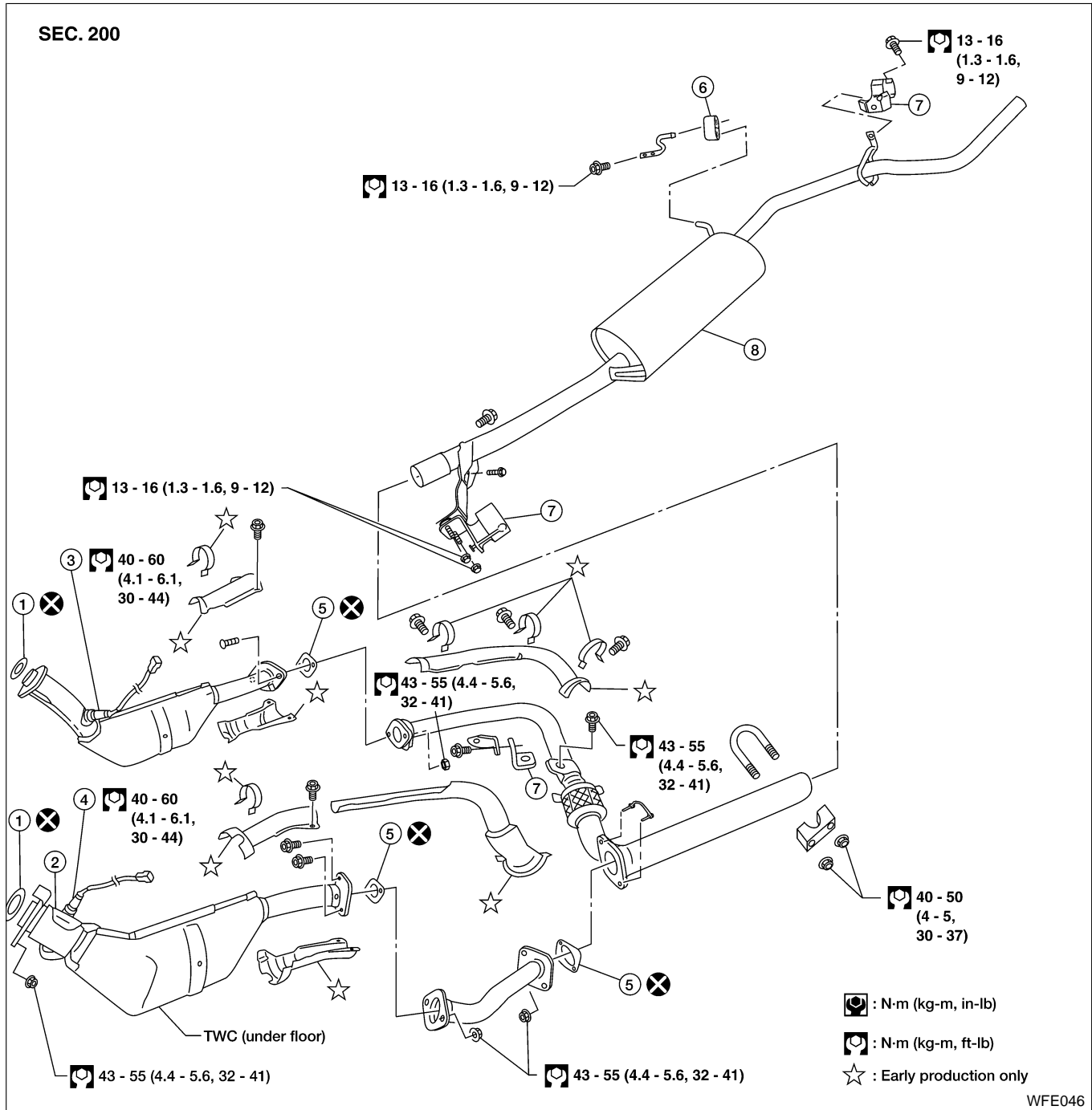

- 1. Gasket
- 2. Front tube
- 3. Heated oxygen sensor 2 (rear) (bank 1)

- 4. Heated oxygen sensor 2 (rear) (bank 2)
- 5. Gasket

- 6. Mounting rubber
- 7. Mounting bracket
- 8. Muffler

# EXHAUST SYSTEM

Removal and Installation (Cont'd)

## VG33ER Models

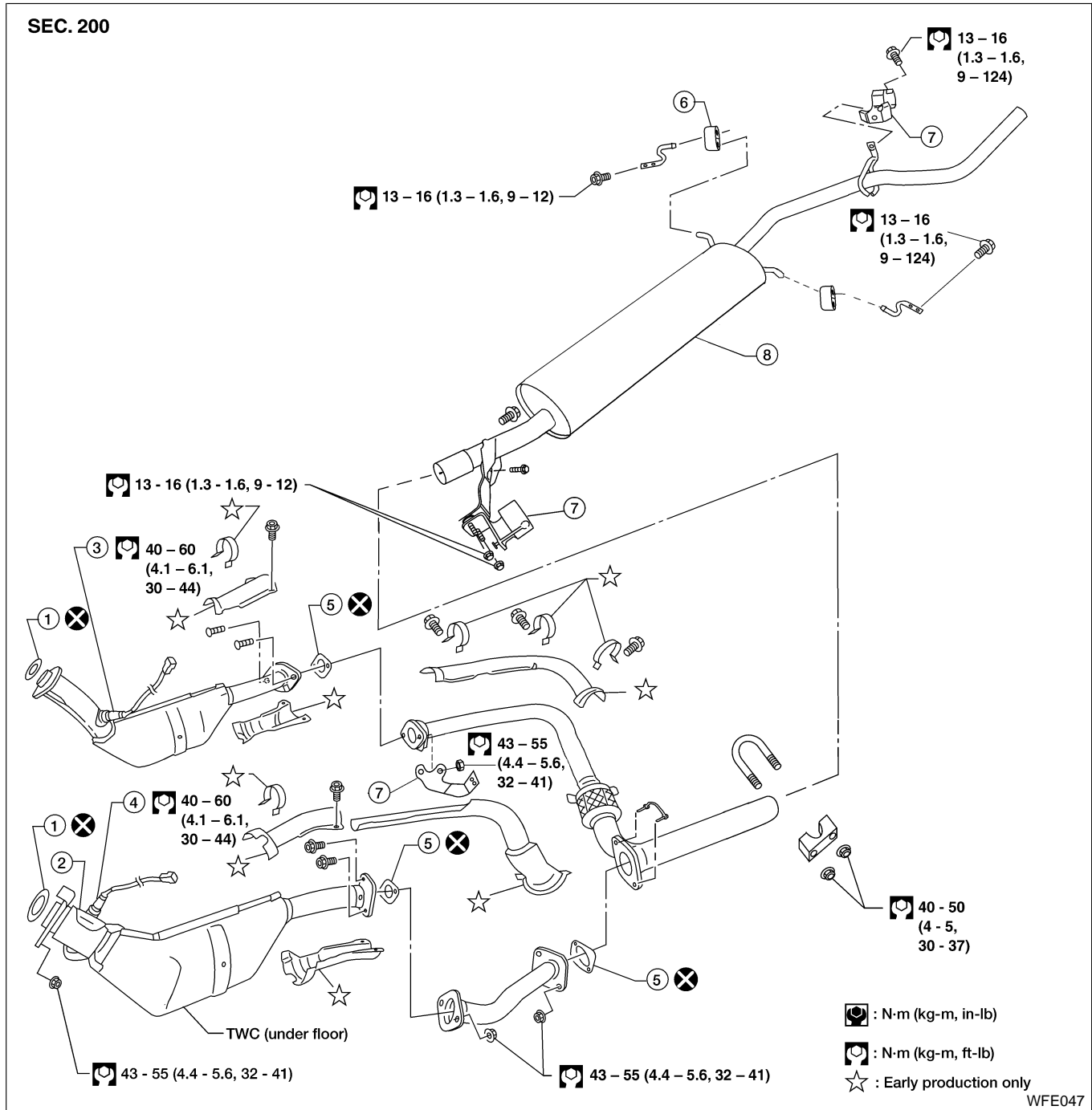

- |  |  |                     |
|--|--|---------------------|
| 1. Gasket                                    | 4. Heated oxygen sensor 2 (rear)<br>(bank 2) | 6. Mounting rubber  |
| 2. Front tube                                | 5. Gasket                                    | 7. Mounting bracket |
| 3. Heated oxygen sensor 2 (rear)<br>(bank 1) |  | 8. Muffler          |

GI  
MA  
EM  
LC  
EC  
FE  
CL  
MT  
AT  
TF  
PD  
AX  
SU  
BR  
ST  
RS  
BT  
HA  
SC  
EL  
IDX

## NOTES