

SECTION **EL**

When you read wiring diagrams:

- Read GI section, "HOW TO READ WIRING DIAGRAMS".

When you perform trouble diagnoses, read GI section, "HOW TO FOLLOW FLOW CHART IN TROUBLE DIAGNOSES" and "HOW TO PERFORM EFFICIENT DIAGNOSIS FOR AN ELECTRICAL INCIDENT".

- Check for any service bulletins before servicing the vehicle.

CONTENTS

PRECAUTIONS AND PREPARATION	2	Service Data and Specifications (SDS).....	38
Supplemental Restraint System (SRS)		COMBINATION SWITCH	39
"AIR BAG".....	2	Check.....	39
HARNESS CONNECTOR	3	Replacement.....	40
Description.....	3	STEERING SWITCH	41
STANDARDIZED RELAY	5	Check.....	41
Description.....	5	HEADLAMP	42
POWER SUPPLY ROUTING	8	System Description (For USA).....	42
Schematic.....	8	Wiring Diagram (For USA) — H/LAMP —.....	43
Wiring Diagram — POWER —.....	10	Trouble Diagnoses.....	44
Fuse.....	15	Bulb Replacement.....	45
Fusible Link.....	15	Aiming Adjustment.....	45
Circuit Breaker Inspection.....	15	HEADLAMP — Daytime Light System —	48
GROUND DISTRIBUTION	16	System Description (For Canada).....	48
Main Harness.....	16	Operation (For Canada).....	49
Engine Room Harness.....	19	Schematic (For Canada).....	50
Engine Control Harness.....	21	Wiring Diagram (For Canada) — DTRL —.....	51
Engine No. 2 Harness.....	22	Trouble Diagnoses (For Canada).....	54
BATTERY	23	Bulb Replacement.....	55
How to Handle Battery.....	23	Aiming Adjustment.....	55
Service Data and Specifications (SDS).....	26	PARKING, LICENSE AND TAIL LAMPS	56
STARTING SYSTEM	27	Wiring Diagram — TAIL/L —.....	56
System Description.....	27	STOP LAMP	58
Wiring Diagram — START —.....	29	Wiring Diagram — STOP/L —.....	58
Construction.....	31	BACK-UP LAMP	59
Removal and Installation.....	33	Wiring Diagram — BACK/L —.....	59
Pinion/Clutch Check.....	33	FRONT FOG LAMP	60
Service Data and Specifications (SDS).....	33	System Description.....	60
CHARGING SYSTEM	34	Wiring Diagram — F/FOG —.....	61
System Description.....	34	Aiming Adjustment.....	62
Wiring Diagram — CHARGE —.....	35	Removal and Installation.....	63
Trouble Diagnoses.....	36	Bulb and Lens Replacement.....	63
Construction.....	37	TURN SIGNAL AND HAZARD WARNING LAMPS	64
Removal and Installation.....	38	System Description.....	64

CONTENTS (Cont'd.)

Wiring Diagram — TURN —	66	Schematic	96
Trouble Diagnoses	68	Wiring Diagram — WARN —	97
Electrical Components Inspection	68	Electrical Components Inspection	100
ILLUMINATION	69	A/T INDICATOR	101
System Description	69	Wiring Diagram — AT/IND —	101
Wiring Diagram — ILL —	70	WARNING CHIME	102
INTERIOR ROOM LAMP	71	Component Parts and Harness Connector	
Component Parts and Harness Connector		Location	102
Location	71	System Description	103
System Description	72	Wiring Diagram — CHIME —	105
Wiring Diagram — ROOM/L —	74	Trouble Diagnoses	107
Trouble Diagnoses (For models with power door		Electrical Components Inspection	113
locks).....	77	FRONT WIPER AND WASHER	114
SPOT LAMP	78	System Description	114
Wiring Diagram — INT/L —	78	Wiring Diagram — WIPER —	116
METER AND GAUGES	79	Trouble Diagnoses (With intermittent wipers)	118
Component Parts and Harness Connector		Removal and Installation	120
Location	79	Washer Nozzle Adjustment	121
System Description	80	Washer Tube Layout	121
Unified Control Meter	80	HORN	122
How To Change The Display For Odo/Trip		Wiring Diagram — HORN —	122
Meter	80	CIGARETTE LIGHTER	123
Combination Meter	82	Wiring Diagram — CIGAR —	123
With Tachometer	82	AUDIO	124
Without Tachometer	83	System Description	124
Wiring Diagram — METER —	84	Base Audio System	124
Meter/gauge Operation and Odo/Trip Meter		Premium Audio System	124
Segment Check in Diagnosis Mode	85	Wiring Diagram — AUDIO —	125
Diagnosis Function	85	Trouble Diagnoses	128
How To Alternate Diagnosis Mode	85	Inspection	129
Flexible Print Circuit (FPC)	86	AUDIO ANTENNA	130
Disconnect	86	Fixed Antenna Rod Replacement	130
Connect	86	Removal	130
Trouble Diagnoses	87	Installation	130
Preliminary Check	87	POWER DOOR MIRROR	131
Symptom Chart 1 (Malfunction is indicated in		Wiring Diagram — MIRROR —	131
diagnosis mode)	88	AUTOMATIC SPEED CONTROL DEVICE (ASCD)	132
Symptom Chart 2 (No malfunction is indicated		Component Parts and Harness Connector	
in diagnosis mode)	88	Location	132
Power Supply And Ground Circuit Check	89	System Description	133
Inspection/Vehicle Speed Sensor	90	Schematic	135
Inspection/Engine Revolution Signal (Models		Wiring Diagram — ASCD —	136
with tachometer)	90	Fail-Safe System Description	140
Inspection/Fuel Tank Gauge	91	Fail-Safe System Check	141
Inspection/Thermal Transmitter	91	Trouble Diagnoses	142
Electrical Components Inspection	92	ASCD Wire Adjustment	150
Meter/Gauge Resistance Check	92	Electrical Components Inspection	151
Fuel Tank Gauge Unit Check	92	POWER WINDOW	152
Thermal Transmitter Check	93	System Description	152
Vehicle Speed Sensor Signal Check	93	Wiring Diagram — WINDOW —	154
WARNING LAMPS	94	Trouble Diagnoses	156
System Description	94	POWER DOOR LOCK	157

CONTENTS (Cont'd.)

Component Parts and Harness Connector	Description	207	GI
Location	Input/Output Operation Signal	208	MA
System Description	Schematic	210	
Schematic	LOCATION OF ELECTRICAL UNITS	212	EM
Wiring Diagram — D/LOCK —	Engine Compartment	212	
Trouble Diagnoses	Passenger Compartment	213	
MULTI-REMOTE CONTROL SYSTEM	HARNES LAYOUT	215	LC
Component Parts and Harness Connector	Outline	215	
Location	How to Read Harness Layout	216	
System Description	Main Harness	218	EC
Schematic	Engine Room Harness	220	
Wiring Diagram — MULTI —	Engine Control Harness	224	FE
Trouble Diagnoses	Engine No. 2 Harness	226	
Electrical Components Inspection	Chassis and Tail Harness	228	
ID Code Entry Procedure	Room Lamp Harness	229	CL
THEFT WARNING SYSTEM	Door Harness	230	
Component Parts and Harness Connector	Air Bag Harness	231	
Location	BULB SPECIFICATIONS	232	MT
System Description	Headlamp	232	
Schematic	Exterior Lamp	232	
Wiring Diagram — THEFT —	Interior Lamp	232	AT
Trouble Diagnoses	WIRING DIAGRAM CODES (CELL CODES)	233	
SMART ENTRANCE CONTROL UNIT			TF
			PD
			FA
			RA
			BR
			ST
			RS
			BT
			HA
			EL
			IDX

Supplemental Restraint System (SRS) “AIR BAG”

The Supplemental Restraint System “AIR BAG”, used along with a seat belt, helps to reduce the risk or severity of injury to the driver and front passenger in a frontal collision. The Supplemental Restraint System consists of air bag modules (located in the center of the steering wheel and in the instrument panel on the passenger side), a diagnosis sensor unit, a crash zone sensor (4WD models), warning lamp, wiring harness and spiral cable.

The vehicle is equipped with a passenger air bag deactivation switch. Because no rear seat exists where a rear-facing child restraint can be placed, the switch is designed to turn off the passenger air bag so that a rear-facing child restraint can be used in the front passenger seat. The switch is located in the center of the instrument panel, near the ashtray. When the switch is turned to the ON position, the passenger air bag is enabled and could inflate in a frontal collision. When the switch is turned to the OFF position, the passenger air bag is disabled and will not inflate in a frontal collision. A passenger air bag OFF indicator on the instrument panel lights up when the passenger air bag is switched OFF. The driver air bag always remains enabled and is not affected by the passenger air bag deactivation switch.

Information necessary to service the system is included in the **RS section** of this Service Manual.

WARNING:

- **To avoid rendering the SRS inoperative, which could increase the risk of personal injury or death in the event of a collision which would result in air bag inflation, all maintenance should be performed by an authorized NISSAN dealer.**
- **Improper maintenance, including incorrect removal and installation of the SRS, can lead to personal injury caused by unintentional activation of the system.**
- **Do not use electrical test equipment on any circuit related to the SRS unless instructed to in this Service Manual. SRS wiring harnesses are covered with yellow insulation either just before the harness connectors or on the complete harness, for easy identification.**
- **The vehicle is equipped with a passenger air bag deactivation switch which can be operated by the customer. When the passenger air bag is switched OFF, the passenger air bag is disabled and will not inflate in a frontal collision. When the passenger air bag is switched ON, the passenger air bag is enabled and could inflate in a frontal collision. After SRS maintenance or repair, make sure the passenger air bag deactivation switch is in the same position (ON or OFF) as when the vehicle arrived for service.**

HARNESS CONNECTOR

Description

HARNESS CONNECTOR (TAB-LOCKING TYPE)

- The tab-locking type connectors help prevent accidental looseness or disconnection.
- The tab-locking type connectors are disconnected by pushing or lifting the locking tab(s). Refer to illustration below.

Refer to EL-4 for description of the slide-locking type connector.

CAUTION:

Do not pull the harness when disconnecting the connector.

[Example]

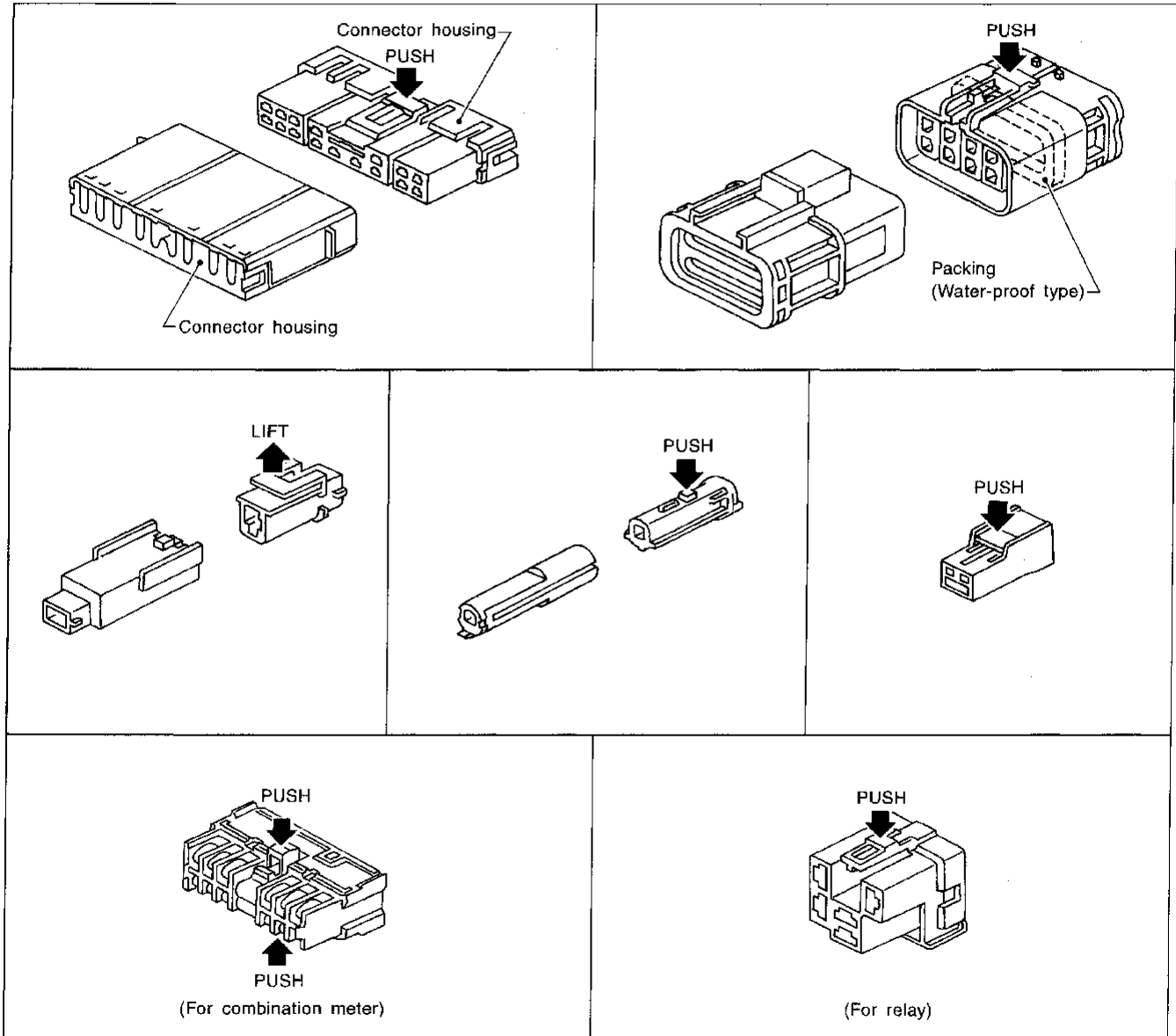

GI
MA
EM
LC
EC
FE
CL
MT
AT
TF
PD
FA
RA
BR
ST
RS
BT
HA

EL

SEL769DA

IDX

HARNESS CONNECTOR

Description (Cont'd)

HARNESS CONNECTOR (SLIDE-LOCKING TYPE)

- A new style slide-locking type connector is used on certain systems and components, especially those related to OBD.
- The slide-locking type connectors help prevent incomplete locking and accidental looseness or disconnection.
- The slide-locking type connectors are disconnected by pushing or pulling the slider. Refer to illustration below.

CAUTION:

- Do not pull the harness or wires when disconnecting the connector.
- Be careful not to damage the connector support bracket when disconnecting the connector.

[Example]

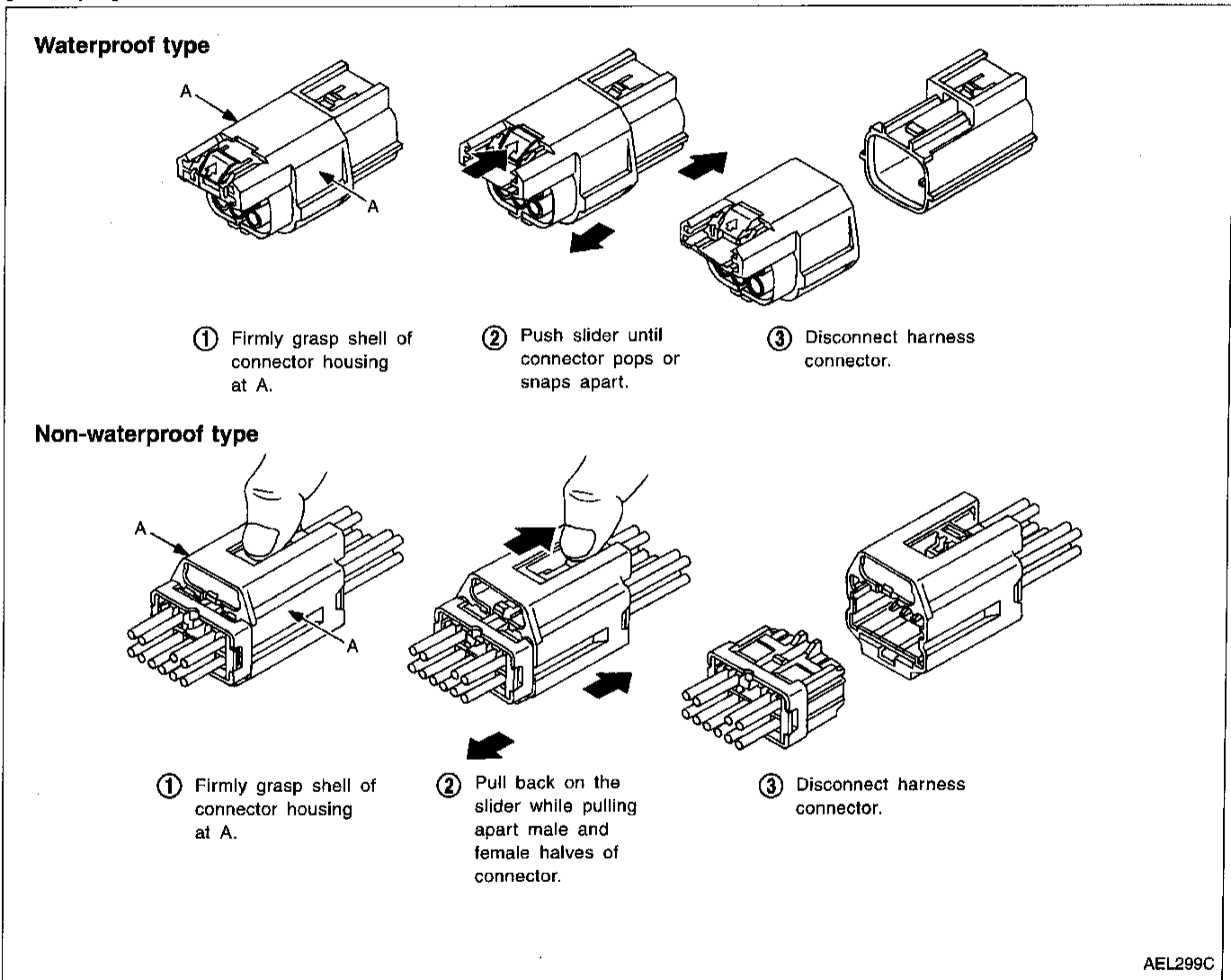

STANDARDIZED RELAY

Description

NORMAL OPEN, NORMAL CLOSED AND MIXED TYPE RELAYS

Relays can be divided into three main types: normal open, normal closed and mixed type relays.

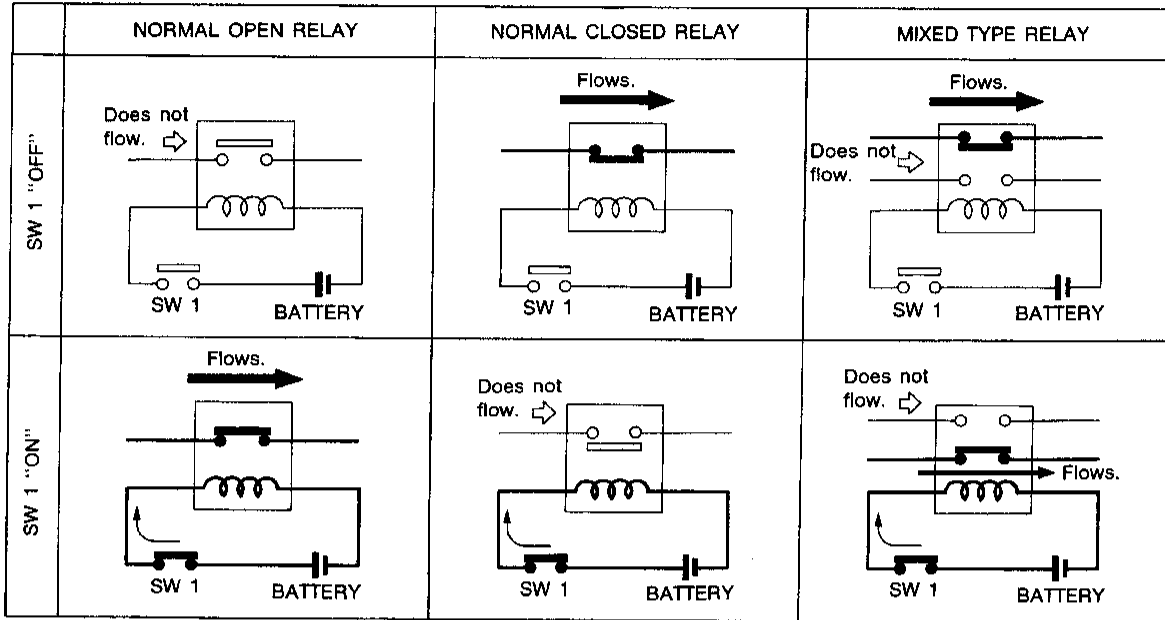

SEL881H

TYPES OF STANDARDIZED RELAYS

1M 1 Make 2M 2 Make
 1T 1 Transfer 1M-1B 1 Make 1 Break

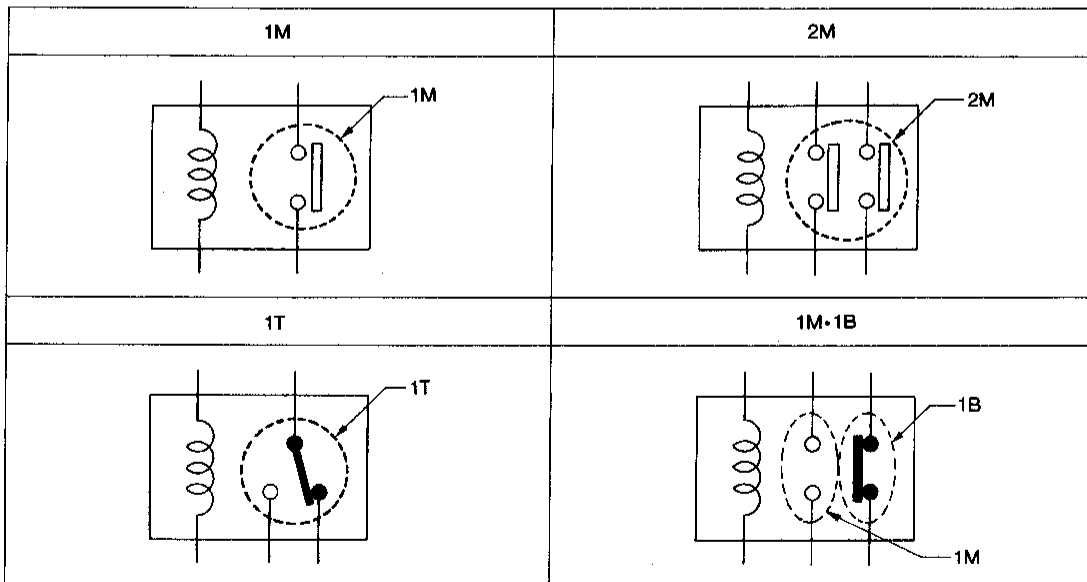

SEL882H

EL

IDX

STANDARDIZED RELAY

Description (Cont'd)

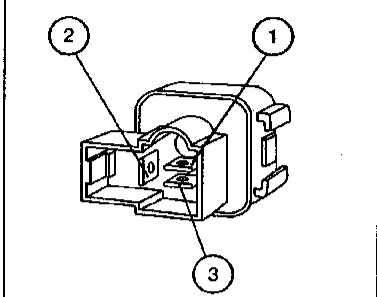
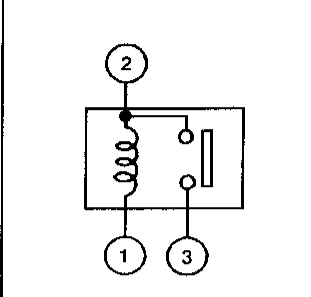
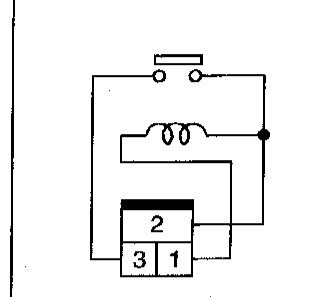
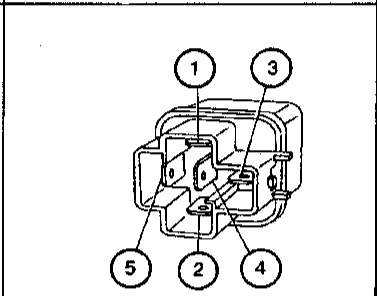
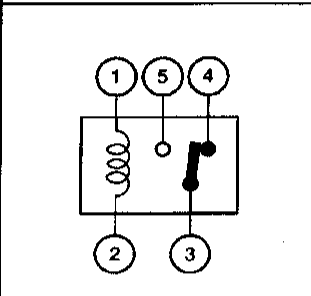
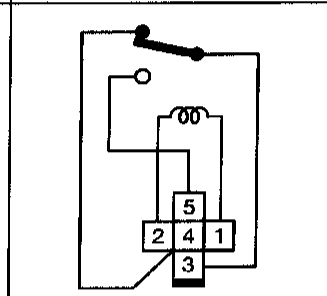
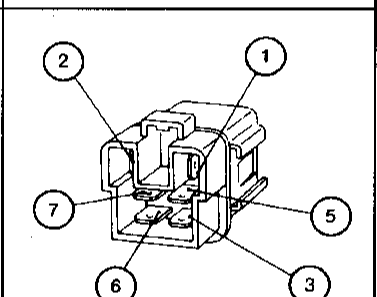
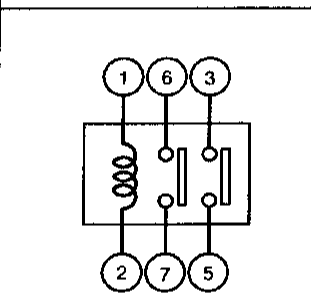
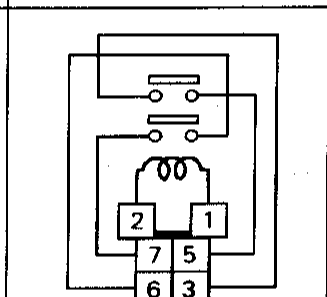
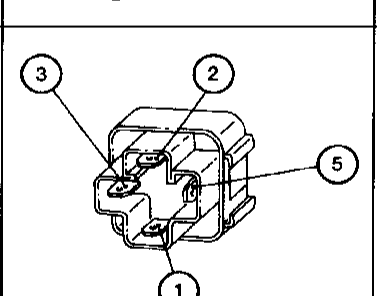
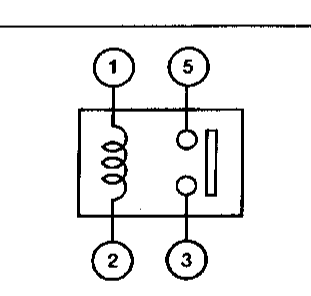
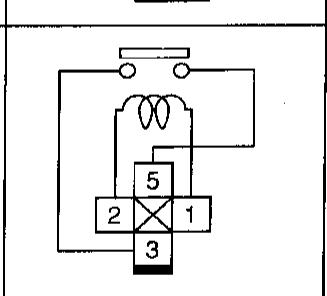
Type	Outer view	Circuit	Connector symbol and connection	Case color
1M				BLACK
1T				BLACK
2M				BROWN
1M				BLUE

The arrangement of terminal numbers on the actual relays may differ from those shown above.

STANDARDIZED RELAY

NOTES

GI

MA

EM

LC

EC

FE

CL

MT

AT

TF

PD

FA

RA

BR

ST

RS

BT

HA

EL

IDX

POWER SUPPLY ROUTING

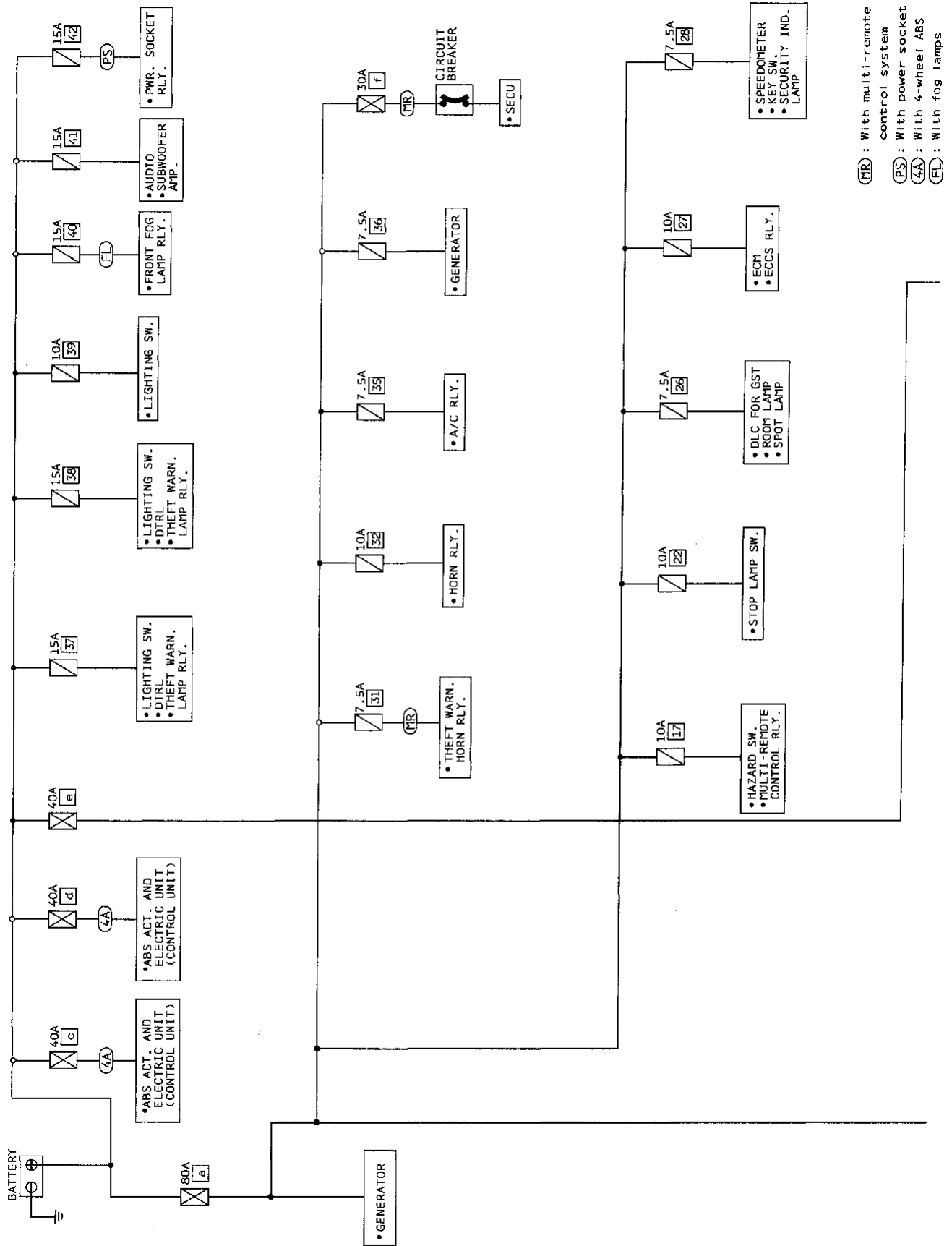

Schematic



POWER SUPPLY ROUTING

Wiring Diagram — POWER — (Cont'd)

EL- POWER-02

-  : With 4-wheel ABS
-  : With power socket
-  : With fog lamps

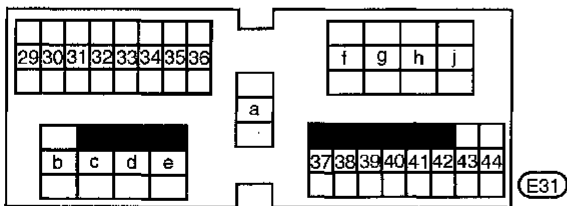
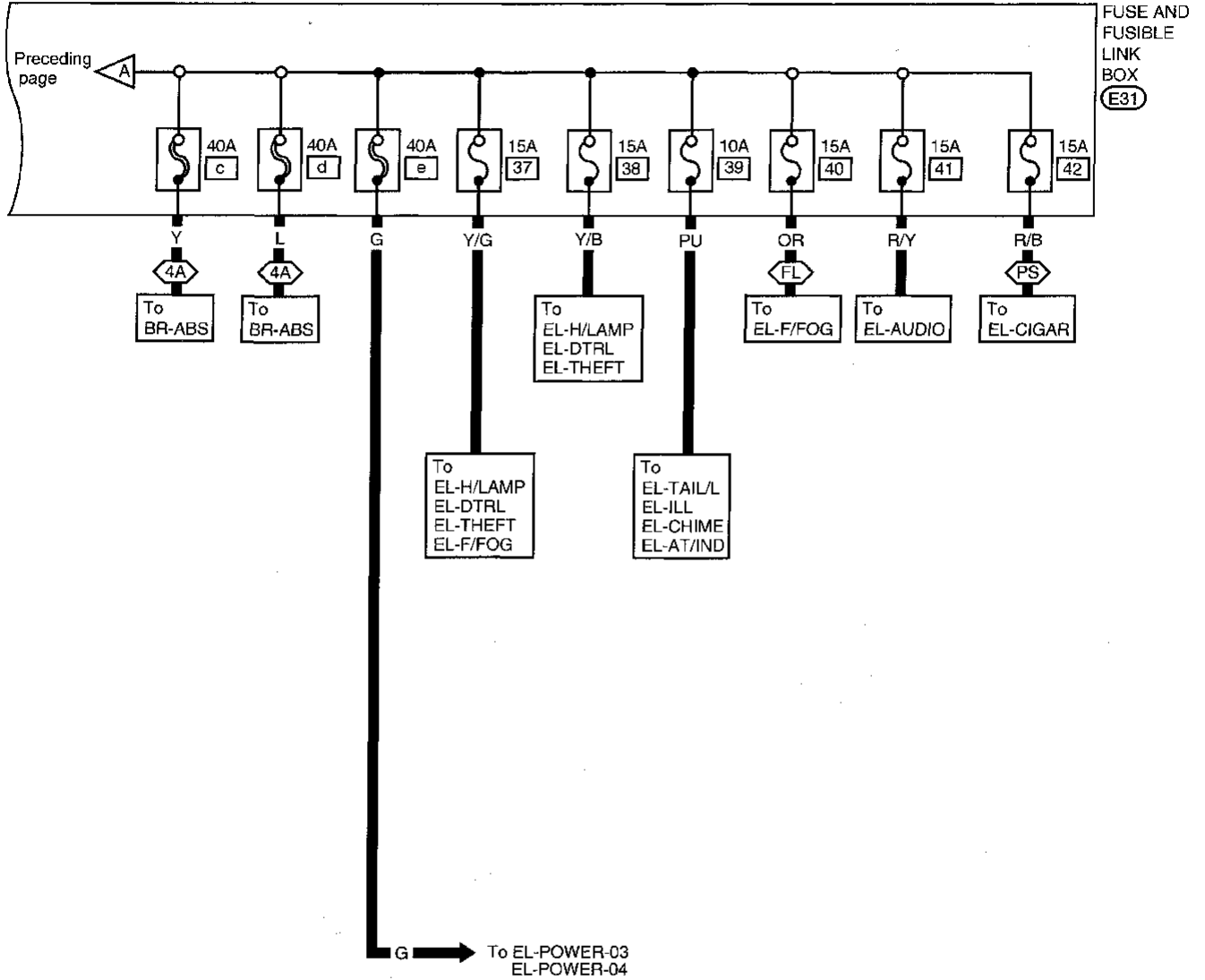

GI
MA
EM
LC
EC
FE
CL
MT
AT
TF
PD
FA
RA
BR
ST
RS
BT
HA

EL

IDX

POWER SUPPLY ROUTING

Wiring Diagram — POWER — (Cont'd)

ACCESSORY POWER SUPPLY — IGNITION SW IN "ACC" OR "ON"

NOTE: For detailed ground distribution information, refer to "GROUND DISTRIBUTION", EL-16.

EL- POWER-03

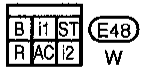
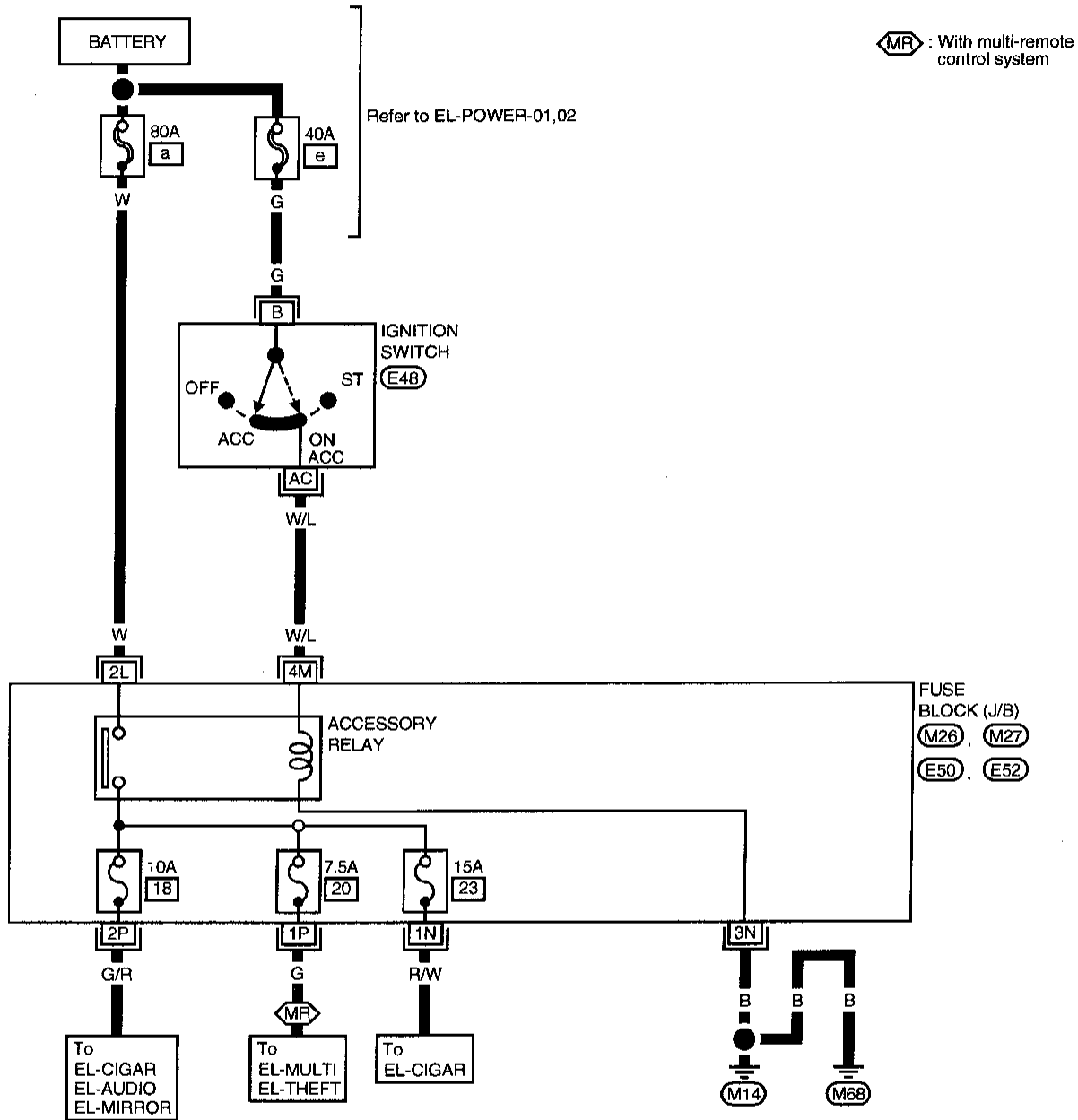

Refer to last page (Foldout page).

(M26), (M27), (E50), (E52)					
1	6	11	16	21	25
2	7	12	17	22	26
3	8	13	18	23	27
4	9	14	19	24	
5	10	15	20		28

POWER SUPPLY ROUTING

Wiring Diagram — POWER — (Cont'd)

IGNITION POWER SUPPLY – IGNITION SW IN “ON” AND/OR “START”

NOTE: For detailed ground distribution information, refer to “GROUND DISTRIBUTION”, EL-16.

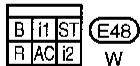
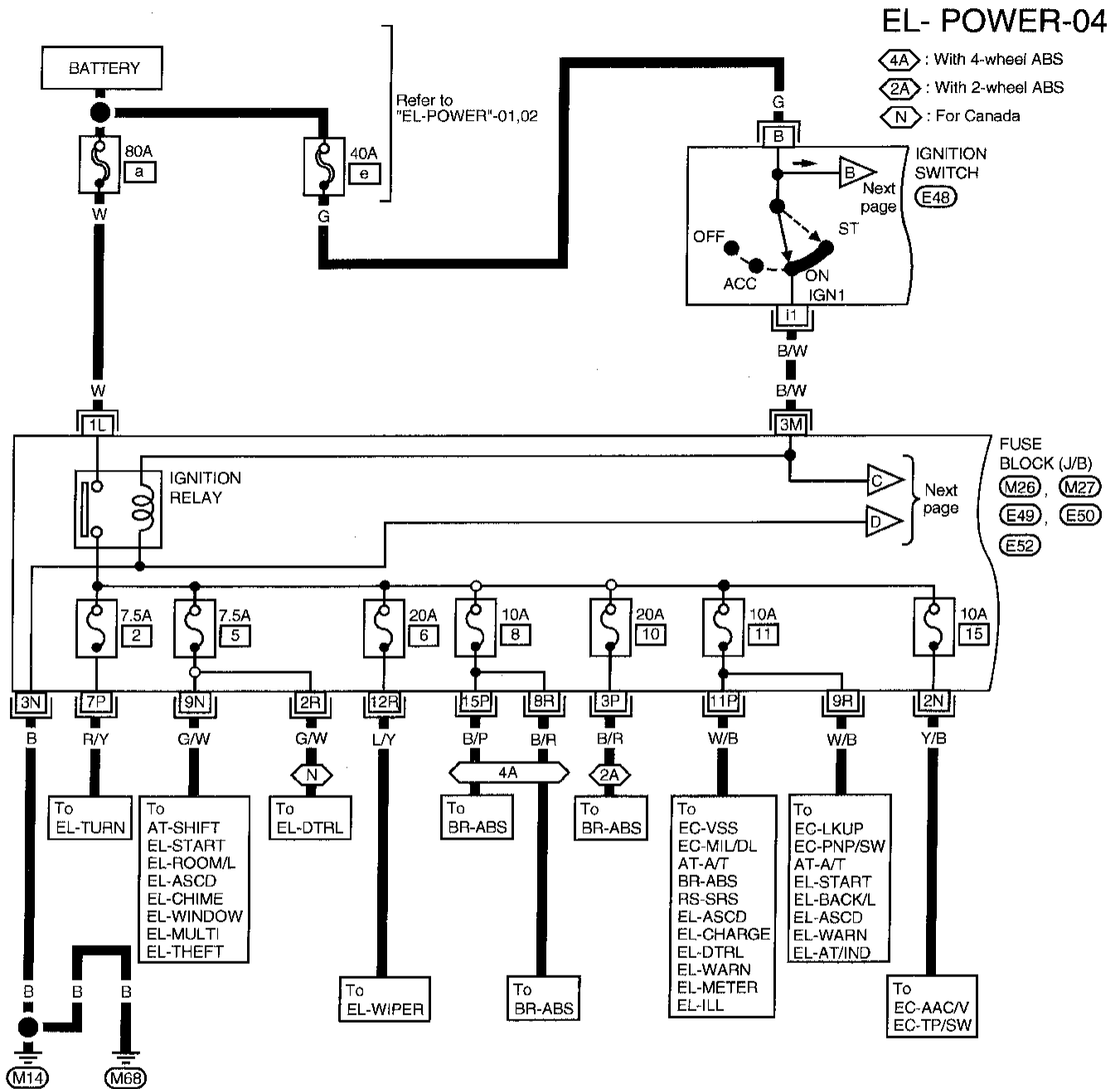

Refer to last page (Foldout page).

(M26), (M27), (E49), (E50), (E52)

1	6	11	16	21	25
2	7	12	17	22	26
3	8	13	18	23	27
4	9	14	19	24	
5	10	15	20		28

GI
MA
EM
LC
EC
FE
CL
MT
AT
TF
PD
FA
RA
BR
ST
RS
BT
HA
EL
IDX

POWER SUPPLY ROUTING

Wiring Diagram — POWER — (Cont'd)

EL- POWER-05

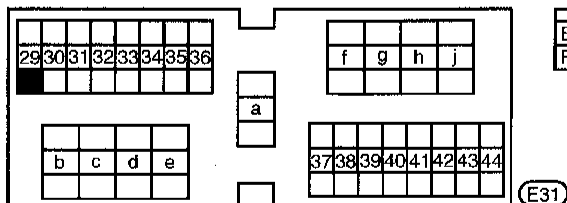
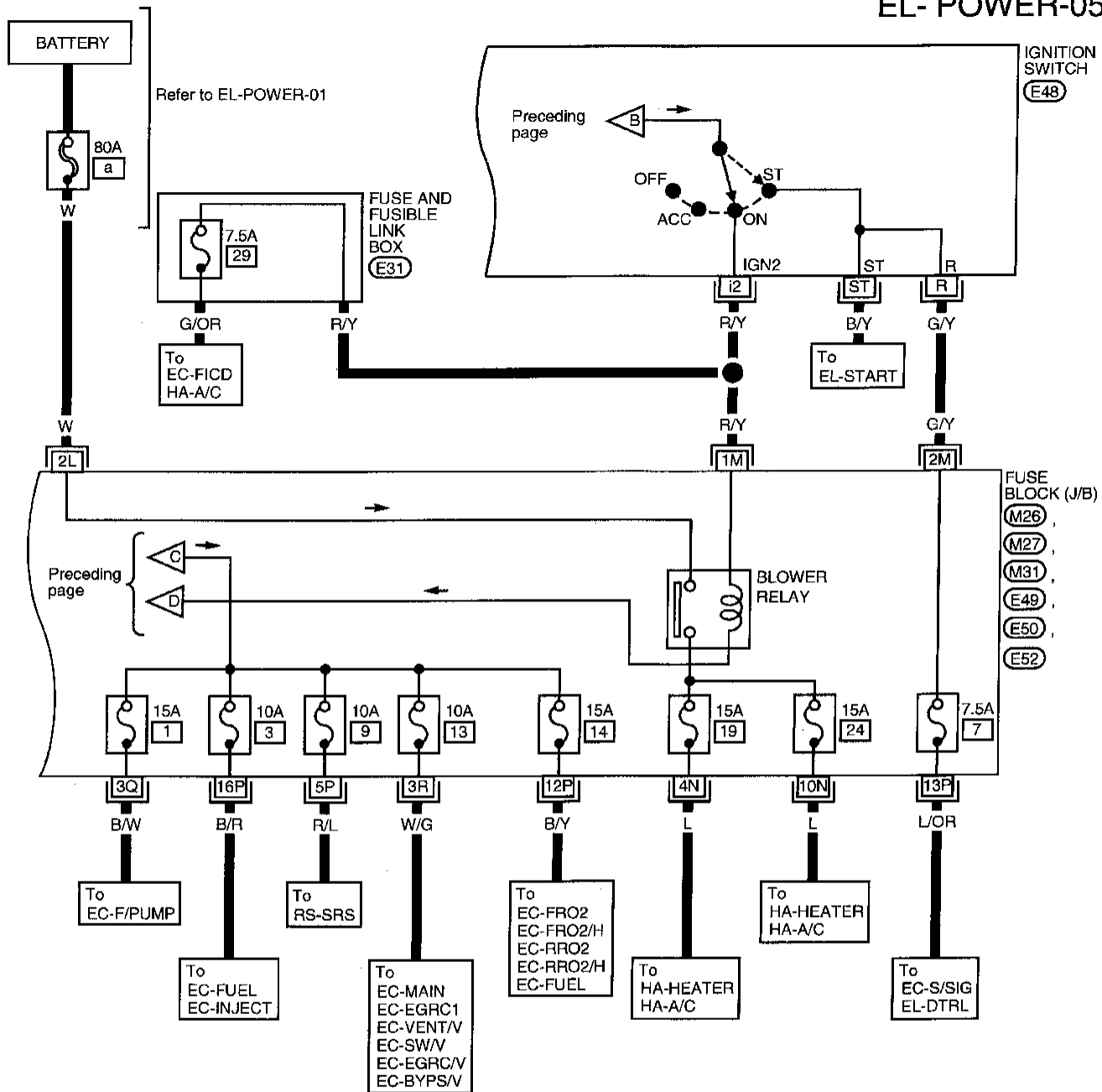

B I | ST (E48)
R AC | I2 W

(E31)

Refer to last page (Foldout page).

M26, M27, M31, E49					
E50, E52					
1	6	11	16	21	25
2	7	12	17	22	26
3	8	13	18	23	27
4	9	14	19	24	
5	10	15	20		28

POWER SUPPLY ROUTING

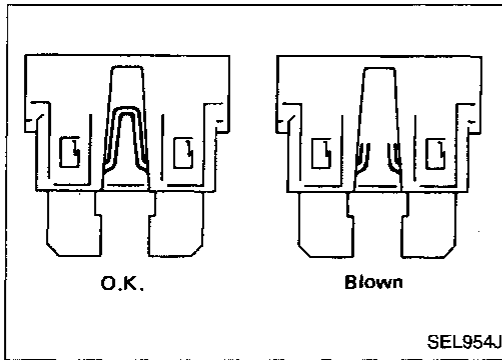

Fuse

- If fuse is blown, be sure to eliminate cause of problem before installing new fuse.
- Use fuse of specified rating. Never use fuse of more than specified rating.
- Do not partially install fuse; always insert it into fuse holder properly.
- Remove fuse for "ELECTRICAL PARTS (BAT)" if vehicle is not used for a long period of time.

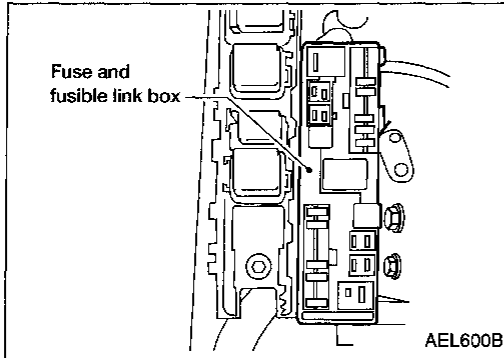

Fusible Link

A melted fusible link can be detected either by visual inspection or by feeling with finger tip. If its condition is questionable, use circuit tester or test lamp.

CAUTION:

- If fusible link should melt, it is possible that critical circuit (power supply or large current carrying circuit) is shorted. In such a case, carefully check and eliminate cause of problem.
- Never wrap outside of fusible link with vinyl tape. Important: Never let fusible link touch any other wiring harness, vinyl or rubber parts.

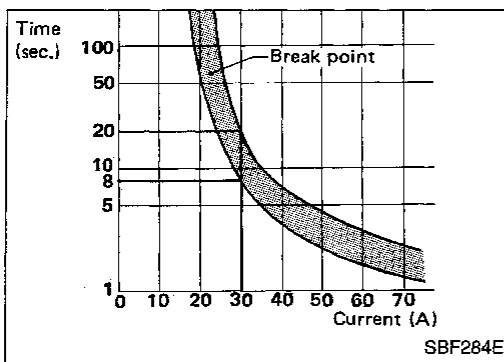

Circuit Breaker Inspection

For example, when current is 30A, the circuit is broken within 8 to 20 seconds.

GI
MA
EM
LC
EC
FE
CL
MT
AT
TF
PD
FA
RA
BR
ST
RS
BT
HA
EL
IDX

GROUND DISTRIBUTION

Main Harness

Body ground

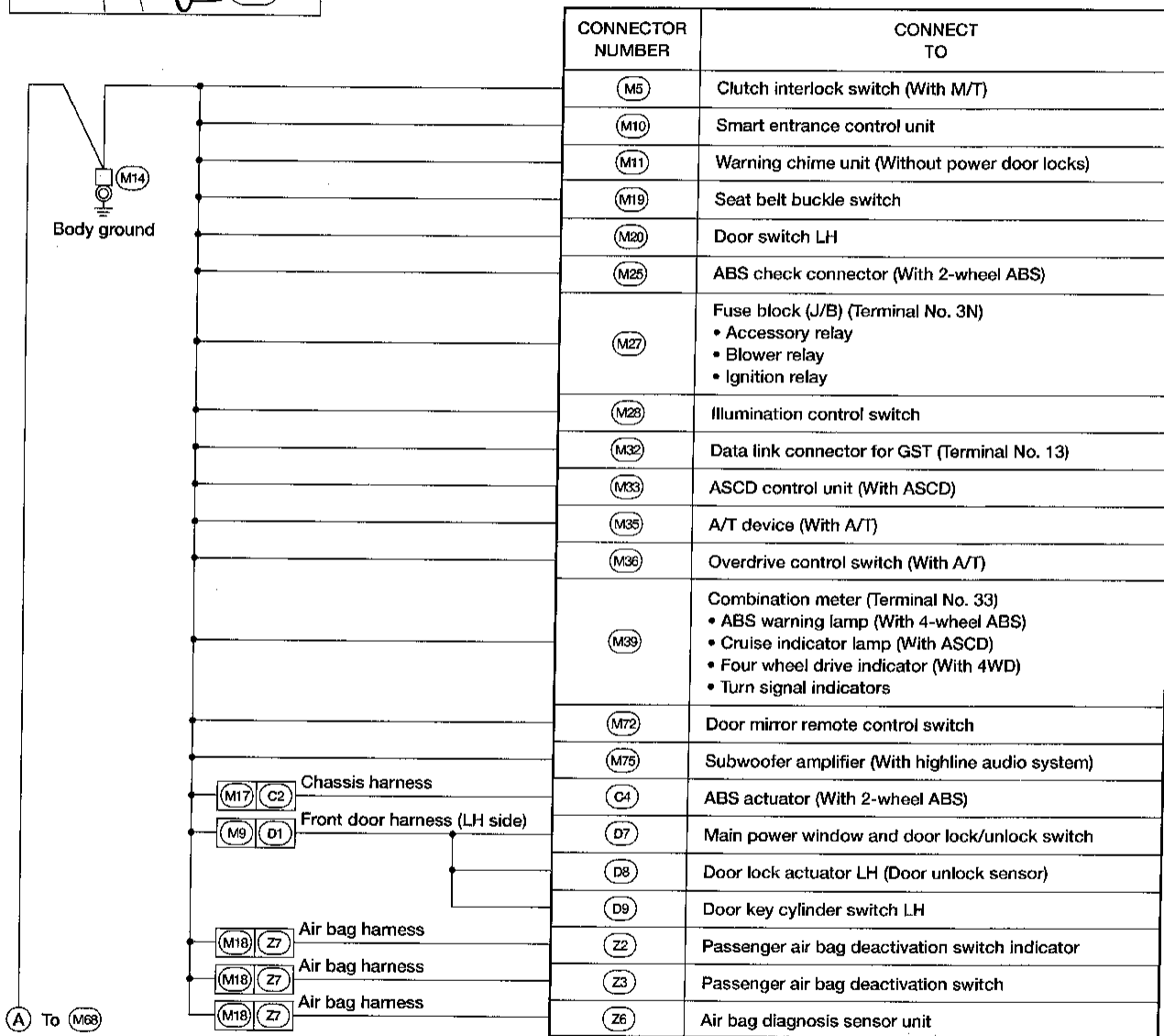
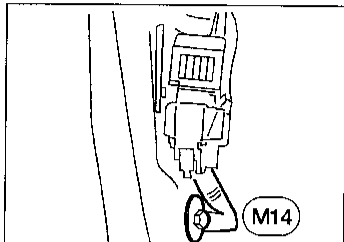

GROUND DISTRIBUTION

Main Harness (Cont'd)

Body ground

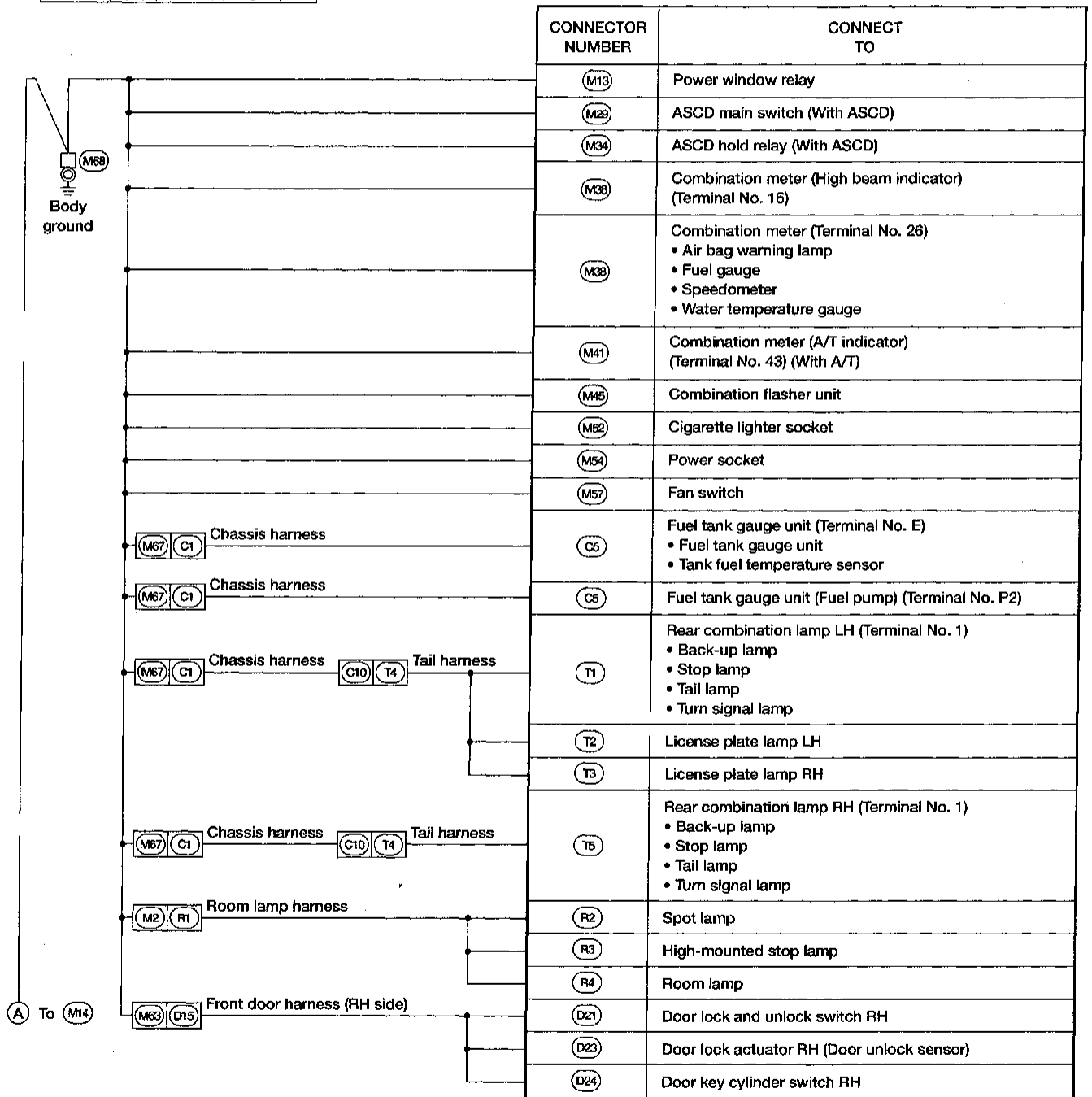
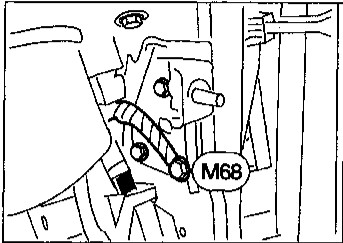

GI
 MA
 EM
 LC
 EC
 FE
 CL
 MT
 AT
 TF
 PD
 FA
 RA
 BR
 ST
 RS
 BT
 HA
 EL
 IDX

GROUND DISTRIBUTION

Main Harness (Cont'd)

Body ground

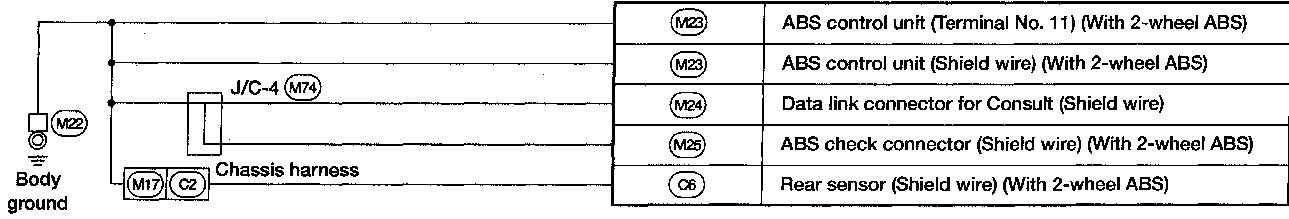
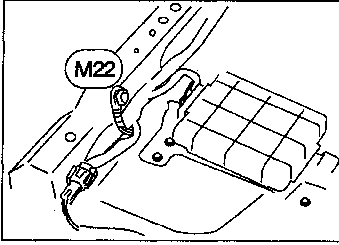

GROUND DISTRIBUTION

Engine Room Harness

Body ground

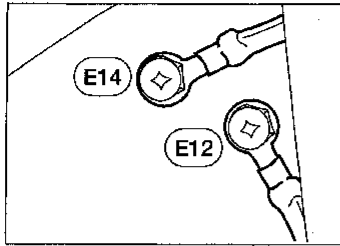

Body ground

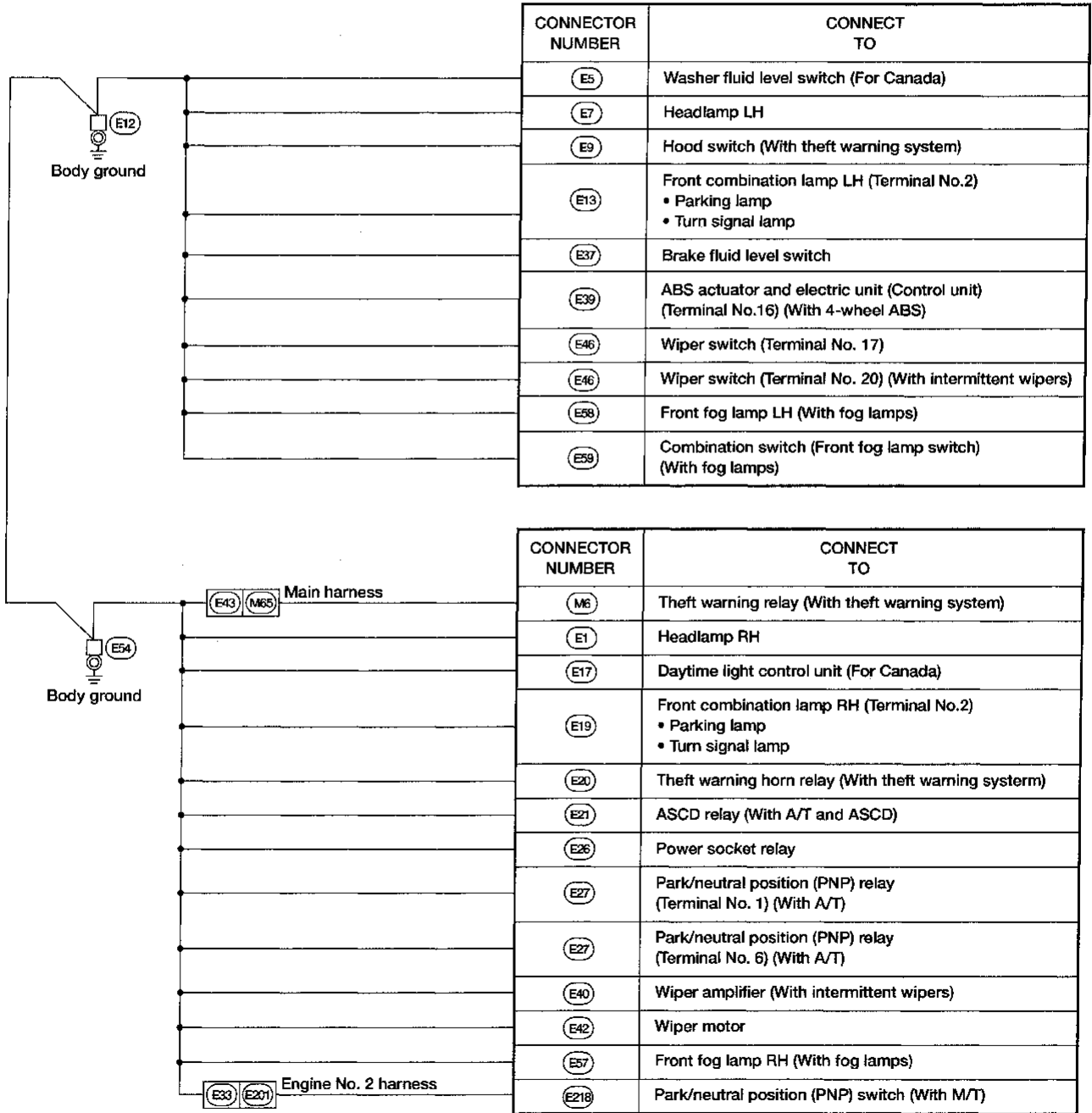
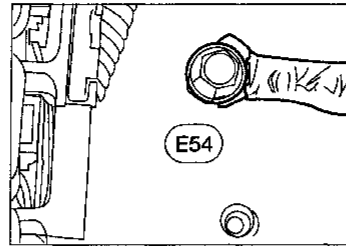

GI
MA
EM
LC
EC
FE
CL
MT
AT
TF
PD
FA
RA
BR
ST
RS
BT
HA
EL
IDX

GROUND DISTRIBUTION

Engine Room Harness (Cont'd)

Body ground

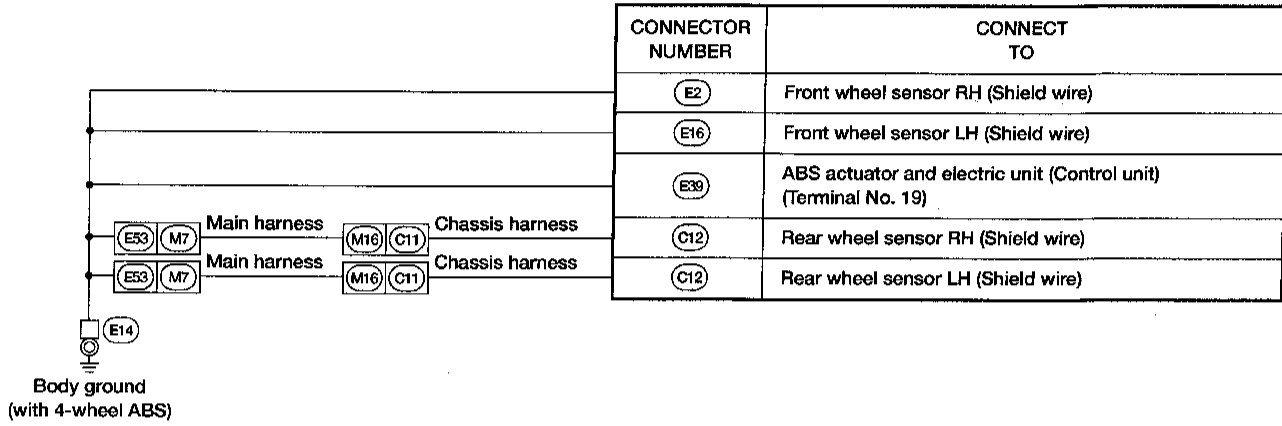
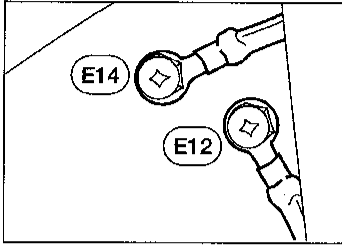

GROUND DISTRIBUTION

Engine Control Harness

Engine ground

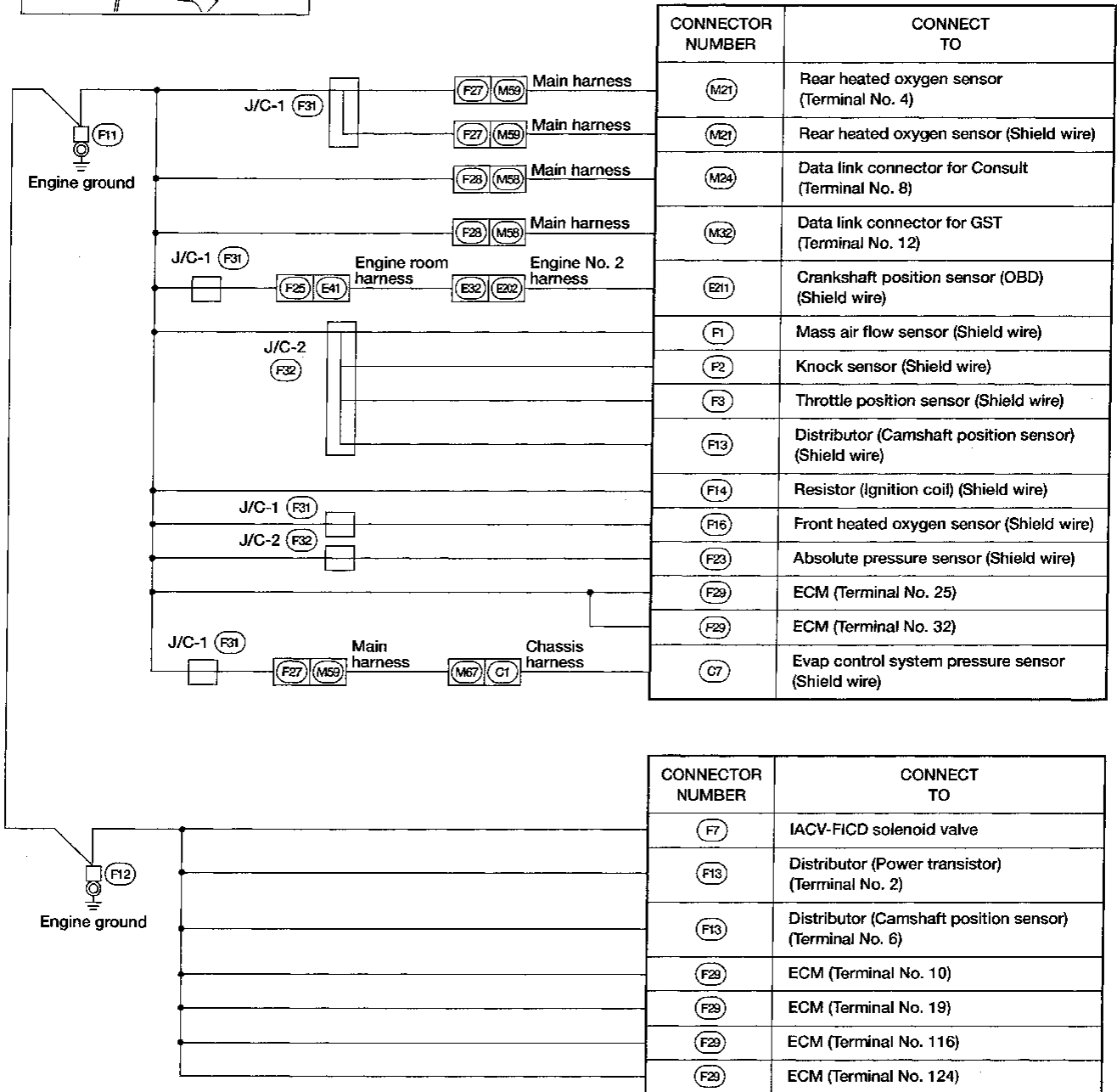
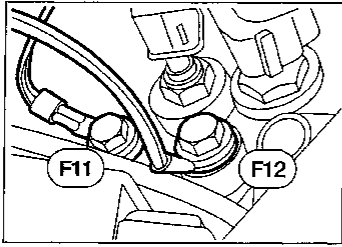

GI
MA
EM
LC
EC
FE
CL
MT
AT
TF
PD
FA
RA
BR
ST
RS
BT
HA
EL
IDX

GROUND DISTRIBUTION

Engine No. 2 Harness

Body ground

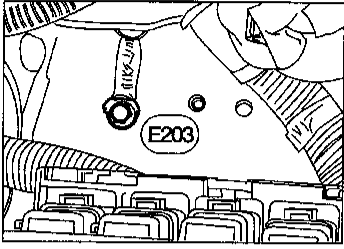

CONNECTOR NUMBER	CONNECT TO
E206	Generator

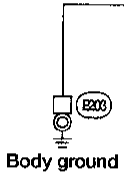

BATTERY

CAUTION:

If it becomes necessary to start the engine with a booster battery and jumper cables:

- Use a 12-volt booster battery.
- After connecting battery cables, ensure that they are tightly clamped to battery terminals for good contact.
- Never add distilled water through the hole used to check specific gravity.

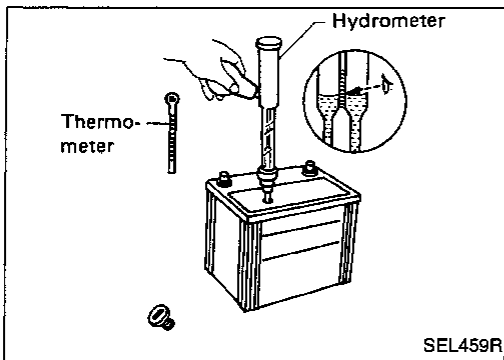
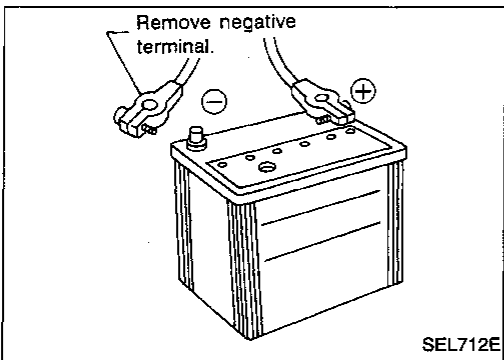
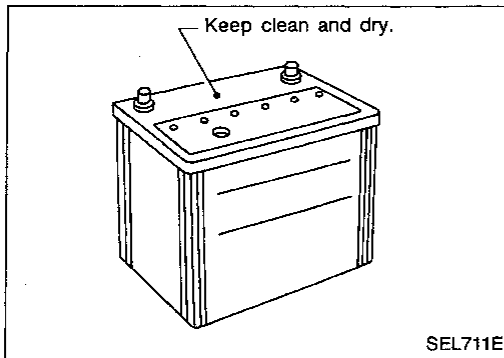

How to Handle Battery

METHODS OF PREVENTING OVER-DISCHARGE

The following precautions must be taken to prevent over-discharging a battery.

- The battery surface (particularly its top) should always be kept clean and dry.
- The terminal connections should be clean and tight.
- At every routine maintenance, check the electrolyte level.

- When the vehicle is not going to be used over a long period of time, disconnect the negative battery terminal. (If the vehicle has an extended storage switch, turn it off.)

- Check the charge condition of the battery. Periodically check the specific gravity of the electrolyte. Keep a close check on charge condition to prevent overdischarge.

GI

MA

EM

LC

EC

FE

CL

MT

AT

TF

PD

FA

RA

BR

ST

RS

BT

HA

EL

IDX

BATTERY

How to Handle Battery (Cont'd)

CHECKING ELECTROLYTE LEVEL

WARNING:

Do not allow battery fluid to come in contact with skin, eyes, fabrics, or painted surfaces. After touching a battery, do not touch or rub your eyes until you have thoroughly washed your hands. If the acid contacts the eyes, skin or clothing, immediately flush with water for 15 minutes and seek medical attention.

Normally the battery does not require additional water. However, when the battery is used under severe conditions, adding distilled water may be necessary during the battery life.

- Remove the cell plug using a suitable tool.
- Add distilled water up to the MAX level.

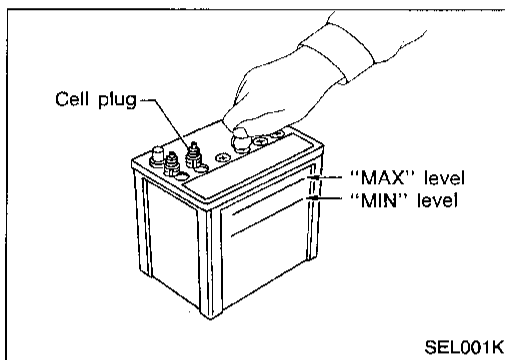

SEL001K

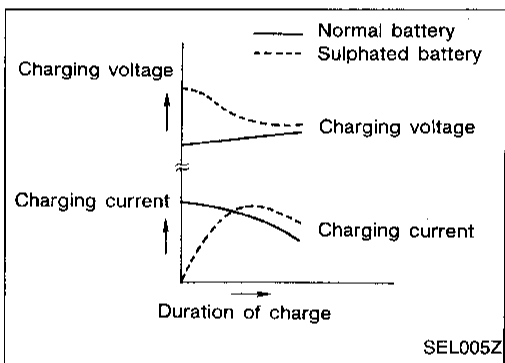

SEL005Z

SULPHATION

A battery will be completely discharged if it is left unattended for a long time and the specific gravity becomes less than 1.100. This may result in sulphation on the cell plates.

To determine if a battery has been "sulphated", note its voltage and current when charging it. As shown in the figure, less current and higher voltage are observed in the initial stage of charging sulphated batteries.

A sulphated battery may sometimes be brought back into service by means of a long, slow charge, 12 hours or more, followed by a battery capacity test.

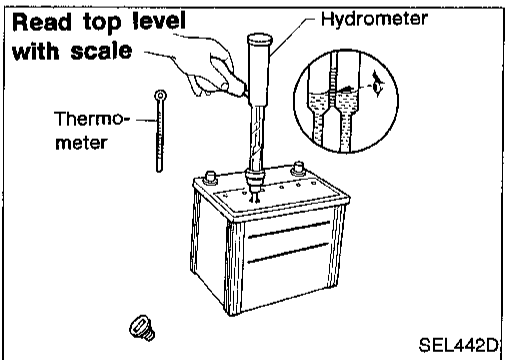

SEL442D

SPECIFIC GRAVITY CHECK

1. Read hydrometer and thermometer indications at eye level.

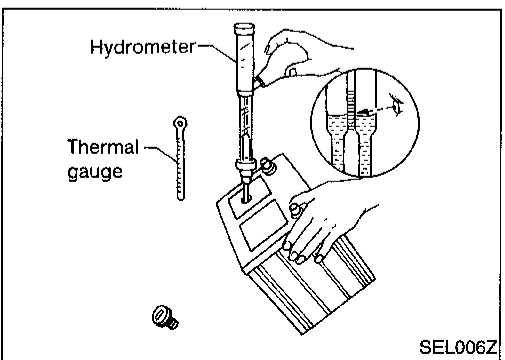

SEL006Z

- When electrolyte level is too low, tilt battery case to raise it for easy measurement.

BATTERY

How to Handle Battery (Cont'd)

2. Use the chart below to correct your hydrometer reading according to electrolyte temperature.

Hydrometer temperature correction

Battery electrolyte temperature °C (°F)	Add to specific gravity reading
71 (160)	0.032
66 (150)	0.028
60 (140)	0.024
54 (129)	0.020
49 (120)	0.016
43 (110)	0.012
38 (100)	0.008
32 (90)	0.004
27 (80)	0
21 (70)	-0.004
16 (60)	-0.008
10 (50)	-0.012
4 (39)	-0.016
-1 (30)	-0.020
-7 (20)	-0.024
-12 (10)	-0.028
-18 (0)	-0.032

Corrected specific gravity	Approximate charge condition
1.260 - 1.280	Fully charged
1.230 - 1.250	3/4 charged
1.200 - 1.220	1/2 charged
1.170 - 1.190	1/4 charged
1.140 - 1.160	Almost discharged
1.110 - 1.130	Completely discharged

GI
MA
EM
LC
EC
FE
CL
MT
AT
TF
PD
FA
RA
BR
ST
RS
BT
HA
EL
IDX

BATTERY

How to Handle Battery (Cont'd)

CHARGING THE BATTERY

CAUTION:

- Do not "quick charge" a fully discharged battery.
- Keep the battery away from open flame while it is being charged.
- When connecting the charger, connect the leads first, then turn on the charger. Do not turn on the charger first, as this may cause a spark.
- If battery electrolyte temperature rises above 60°C (140°F), stop charging. Always charge battery at a temperature below 60°C (140°F).

Charging rates

Amps	Time
50	1 hour
25	2 hours
10	5 hours
5	10 hours

Do not charge at more than 50 ampere rate.

Note: The ammeter reading on your battery charger will automatically decrease as the battery charges. This indicates that the voltage of the battery is increasing normally as the state of charge improves. The charging amps indicated above refer to initial charge rate.

- If, after charging, the specific gravity of any two cells varies more than .050, the battery should be replaced.
- After the battery is charged, always perform a capacity test to assure that the battery is serviceable.

Service Data and Specifications (SDS)

Applied area		USA	Canada
Type		55D23R	65D26R
Capacity	V-AH	12-60	12-65
Cold cranking current (For reference value)	A	356	413

System Description

M/T MODELS

Power is supplied at all times:

- through 40A fusible link (letter **e**, located in the fuse and fusible link box)
- to ignition switch terminal **B**.

With the ignition switch in the START position, power is supplied:

- through terminal **57** of the ignition switch
- to clutch interlock relay terminal **5**.

For models with theft warning system

With the ignition switch in the ON or START position, power is supplied:

- through 7.5A fuse [No. **5**, located in the fuse block (J/B)]
- to theft warning relay terminal **2**.

With the ignition switch in the ON or START position, power is supplied:

- through 10A fuse [No. **11**, located in the fuse block (J/B)]
- to clutch interlock relay terminal **2**.

If the theft warning system is triggered, terminal **1** of the theft warning relay is grounded through terminal **32** of the smart entrance control unit and ground to the clutch interlock relay is interrupted.

When the theft warning system is not operating and clutch pedal is depressed, ground is supplied:

- from clutch interlock switch terminal **2**
- to theft warning relay terminal **3**
- through theft warning relay terminal **4**
- to clutch interlock relay terminal **1**.

For models without theft warning system

With the ignition switch in the ON or START position, power is supplied:

- through 10A fuse [No. **11**, located in the fuse block (J/B)]
- to clutch interlock relay terminal **2**.

When the clutch pedal is depressed, ground is supplied:

- from clutch interlock switch terminal **2**
- to clutch interlock relay terminal **1**.

Ground is supplied to clutch interlock switch terminal **1** through body grounds **M14** and **M68**.

The clutch interlock relay is energized and power is supplied:

- from terminal **3** of the clutch interlock relay
- to terminal **2** of the starter motor windings.

The starter motor plunger closes and provides a closed circuit between the battery and the starter motor. The starter motor is grounded to the engine block. With power and ground supplied, cranking occurs and the engine starts.

GI

MA

EM

LC

EC

FE

CL

MT

AT

TF

PD

FA

RA

BR

ST

RS

BT

HA

EL

IDX

STARTING SYSTEM

System Description (Cont'd)

A/T MODELS

Power is supplied at all times:

- through 40A fusible link (letter **E**), located in the fuse and fusible link box)
- to ignition switch terminal **B**.

With the ignition switch in the START position, power is supplied:

- through terminal **5T** of the ignition switch
- to park/neutral position (PNP) relay terminal **5**.

For models with theft warning system

With the ignition switch in the ON or START position, power is supplied:

- through 7.5A fuse [No. **5**], located in the fuse block (J/B)]
- to theft warning relay terminal **2**.

With the ignition switch in the ON or START position, power is supplied:

- through 10A fuse [No. **11**], located in the fuse block (J/B)]
- to PNP switch terminal **1**.

With the selector lever in the P or N position, power is supplied:

- from PNP switch terminal **2**
- to PNP relay terminal **2**.

If the theft warning system is triggered, terminal **1** of the theft warning relay is grounded through terminal **32** of the smart entrance control unit and ground to the PNP relay is interrupted.

When the theft warning system is not operating, ground is supplied:

- from theft warning relay terminal **3**
- through theft warning relay terminal **4**
- to PNP relay terminal **1**.

For models without theft warning system

With the ignition switch in the ON or START position, power is supplied:

- through 10A fuse [No. **11**], located in the fuse block (J/B)]
- to PNP switch terminal **1**.

With the selector lever in the P or N position, power is supplied:

- from PNP switch terminal **2**
- to PNP relay terminal **2**.

Ground is supplied to PNP relay terminal **1** through body grounds **E12** and **E54**.

The PNP relay is energized and power is supplied:

- from terminal **3** of the PNP relay
- to terminal **2** of the starter motor windings.

The starter motor plunger closes and provides a closed circuit between the battery and the starter motor. The starter motor is grounded to the engine block. With power and ground supplied, cranking occurs and the engine starts.

THEFT WARNING SYSTEM

The theft warning system will interrupt ground to clutch interlock relay (M/T models) or PNP relay (A/T models) if the system is triggered. The starter motor will then not crank, and the engine will not start. Refer to "THEFT WARNING SYSTEM" (EL-187).

STARTING SYSTEM

Wiring Diagram — START —

M/T MODELS

EL-START-01

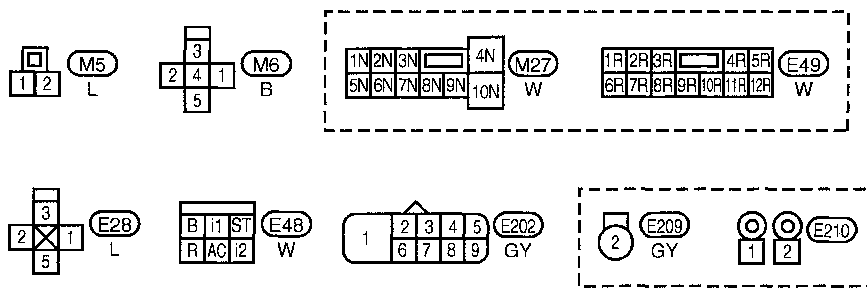
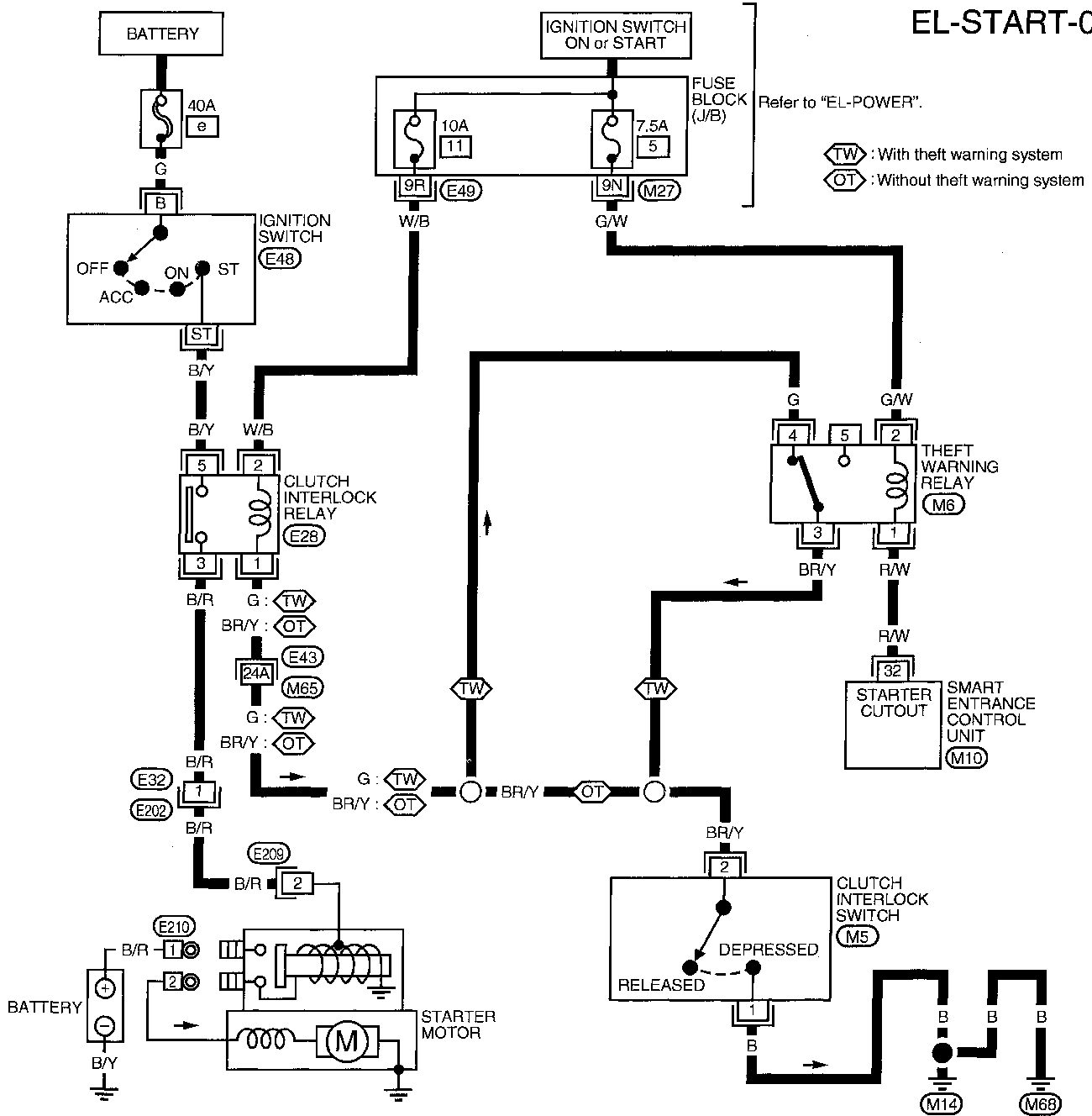

Refer to last page (Foldout page).

(M65), (E43)
(M10)

GI
MA
EM
LC
EC
FE
CL
MT
AT
TF
PD
FA
RA
BR
ST
RS
BT
HA
EL
IDX

STARTING SYSTEM

Wiring Diagram — START — (Cont'd)

AT MODELS

EL-START-02

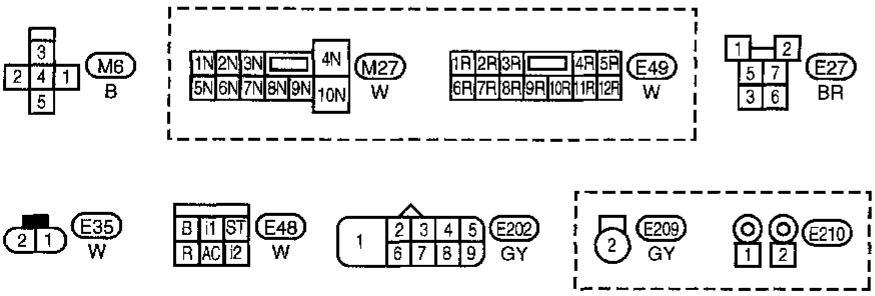
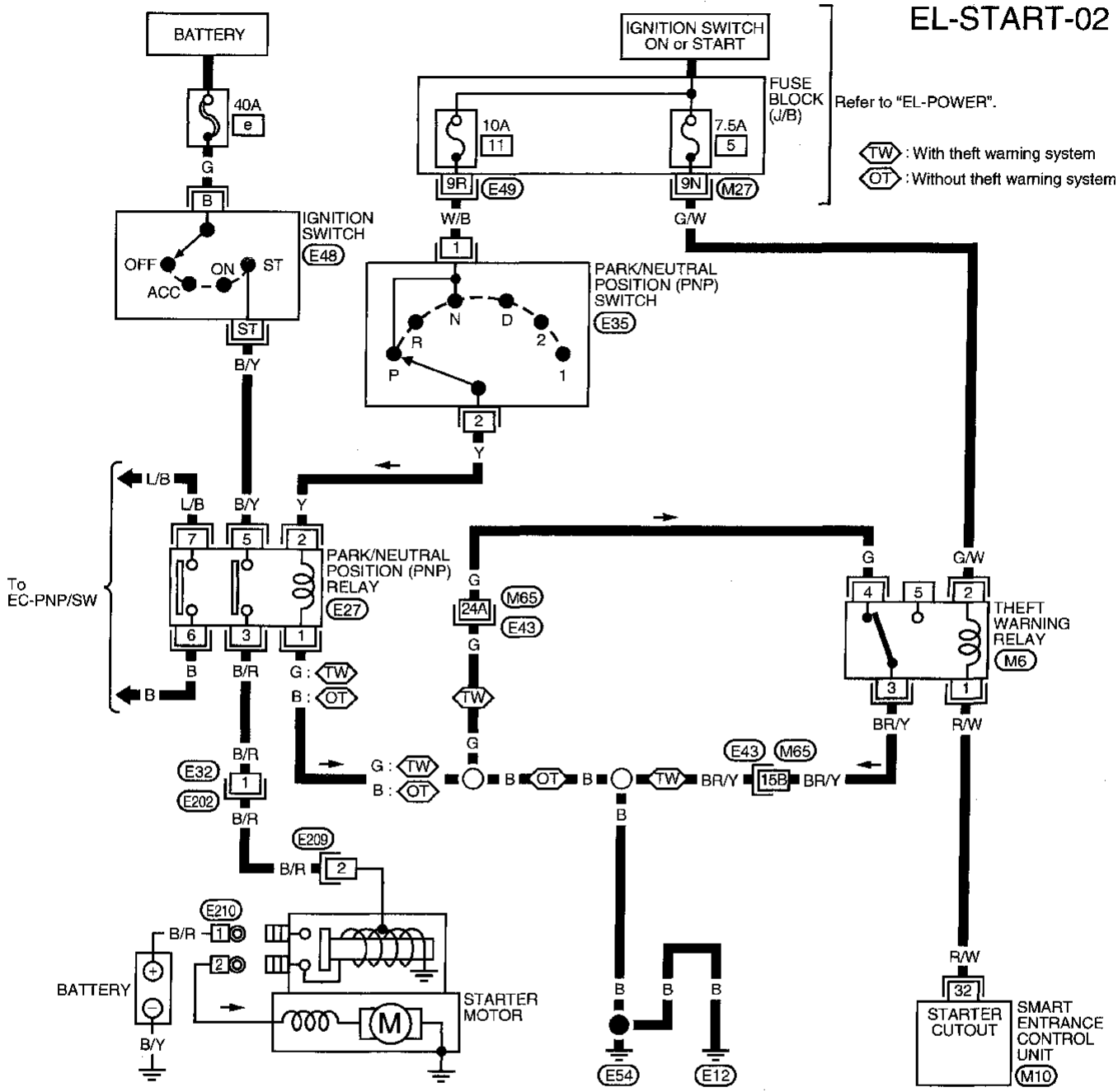

Refer to last page (Foldout page).

M65 , E43
M10

STARTING SYSTEM

Construction

CALIFORNIA, USA

SEC. 233
M003T70381ZC

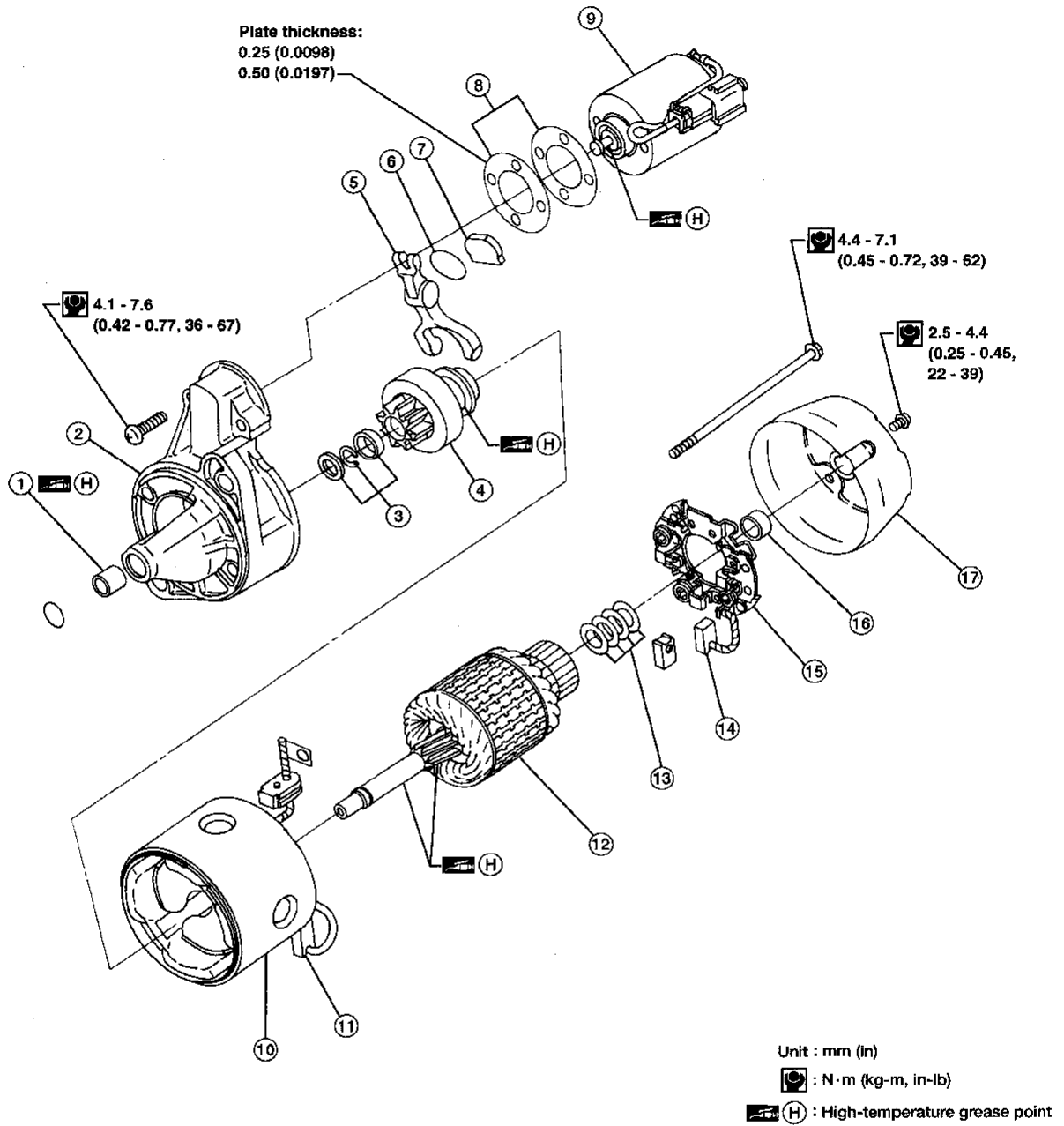

AEL675B

- ① Sleeve bearing
- ② Gear case
- ③ Pinion stopper set
- ④ Pinion assembly
- ⑤ Shift lever
- ⑥ Plate

- ⑦ Packing
- ⑧ Adjusting plate
- ⑨ Magnetic switch assembly
- ⑩ Yoke
- ⑪ Brush (+)
- ⑫ Armature

- ⑬ Washer
- ⑭ Brush (-)
- ⑮ Brush holder
- ⑯ Sleeve bearing
- ⑰ Rear cover

GI
MA
EM
LC
EC
FE
CL
MT
AT
TF
PD
FA
RA
BR
ST
RS
BT
HA
EL
IDX

STARTING SYSTEM

Construction (Cont'd)

NON-CALIFORNIA, USA AND CANADA

SEC. 233
M000T60081AC

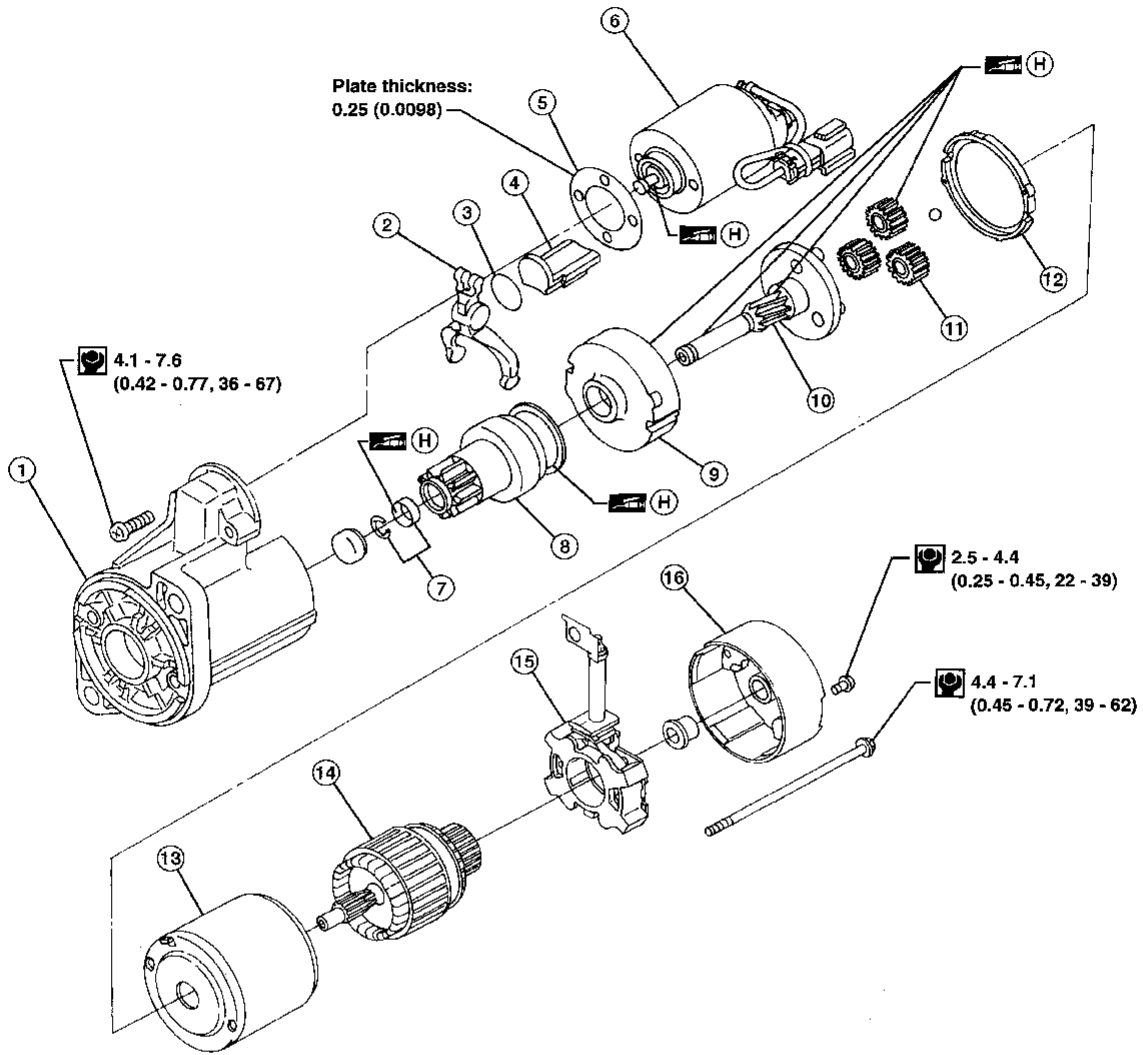

Unit : mm (in)

: N·m (kg-m, in-lb)

(H) : High-temperature grease point

AEL674B

- ① Gear case
- ② Shift lever
- ③ Plate
- ④ Packing
- ⑤ Adjusting plate
- ⑥ Magnetic switch assembly

- ⑦ Pinion stopper set
- ⑧ Pinion assembly
- ⑨ Internal gear
- ⑩ Pinion shaft
- ⑪ Planetary gear

- ⑫ Packing
- ⑬ Yoke
- ⑭ Armature
- ⑮ Brush holder assembly
- ⑯ Rear cover

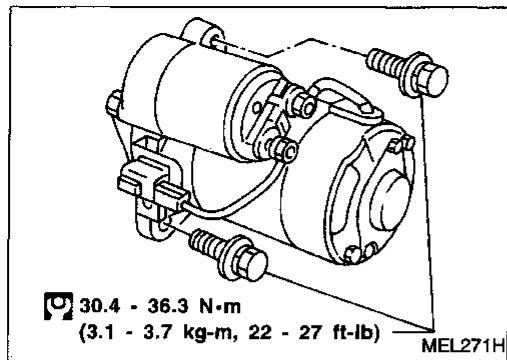

Removal and Installation

REMOVAL

1. Remove engine undercover.
2. Remove two bolts and starter.

INSTALLATION

To install, reverse the removal procedure.

Pinion/Clutch Check

1. Inspect pinion teeth.
 - Replace pinion if teeth are worn or damaged. (Also check condition of ring gear teeth.)
2. Inspect reduction gear teeth.
 - Replace reduction gear if teeth are worn or damaged. (Also check condition of armature shaft gear teeth.)
3. Check to see if pinion locks in one direction and rotates smoothly in the opposite direction.
 - If it locks or rotates in both directions, or unusual resistance is evident, replace.

Service Data and Specifications (SDS)

STARTER

Type	M003T70381ZC		M000T60081AC	
	MITSUBISHI			
	Non-reduction		Reduction	
Applied model	California, USA		Non-California, USA and Canada	
System voltage	V	12		
No-load				
Terminal voltage	V	11.5	11.0	
Current	A	60 Max.	90 Max.	
Motor revolution	rpm	6,500 Min.	2,500 Min.	
Minimum diameter of commutator	mm (in)	31.4 (1.236)	28.8 (1.134)	
Minimum length of brush	mm (in)	11.5 (0.453)	7.0 (0.276)	
Brush spring tension	N (kg, lb)	13.7 - 25.5 (1.4 - 2.6, 3.1 - 5.7)	11.8 - 23.5 (1.20 - 2.40, 2.65 - 5.28)	
Clearance of bearing metal and armature shaft	mm (in)	0.2 (0.008)	0.2 (0.008)	
Clearance between pinion front edge and pinion stopper	mm (in)	0.5 - 2.0 (0.020 - 0.079)	0.5 - 2.0 (0.020 - 0.079)	

GI

MA

EM

LC

EC

FE

CL

MT

AT

TF

PD

FA

RA

BR

ST

RS

BT

HA

EL

IDX

CHARGING SYSTEM

System Description

The generator provides DC voltage to operate the vehicle's electrical system and to keep the battery charged. The voltage output is controlled by the IC regulator.

Power is supplied at all times to generator terminal ④ through:

- 80A fusible link (letter **a**, located in the fuse and fusible link box), and
- 7.5A fuse (No. **36**, located in the fuse and fusible link box).

Terminal ① supplies power to charge the battery and operate the vehicle's electrical system. Output voltage is controlled by the IC regulator at terminal ④ detecting the input voltage. The charging circuit is protected by the 80A fusible link.

Terminal ② of the generator supplies ground through body ground **E203**.

With the ignition switch in the ON or START position, power is supplied:

- through 10A fuse [No. **11**, located in the fuse block (J/B)]
- to combination meter terminal **29** for the charge warning lamp.

Ground is supplied to terminal **27** of the combination meter through terminal ③ of the generator. With power and ground supplied, the charge warning lamp will illuminate. When the generator is providing sufficient voltage with the engine running, the ground is opened and the charge warning lamp will not illuminate.

If the charge warning lamp illuminates with the engine running, a fault is indicated.

CHARGING SYSTEM

Wiring Diagram — CHARGE —

EL-CHARGE-01

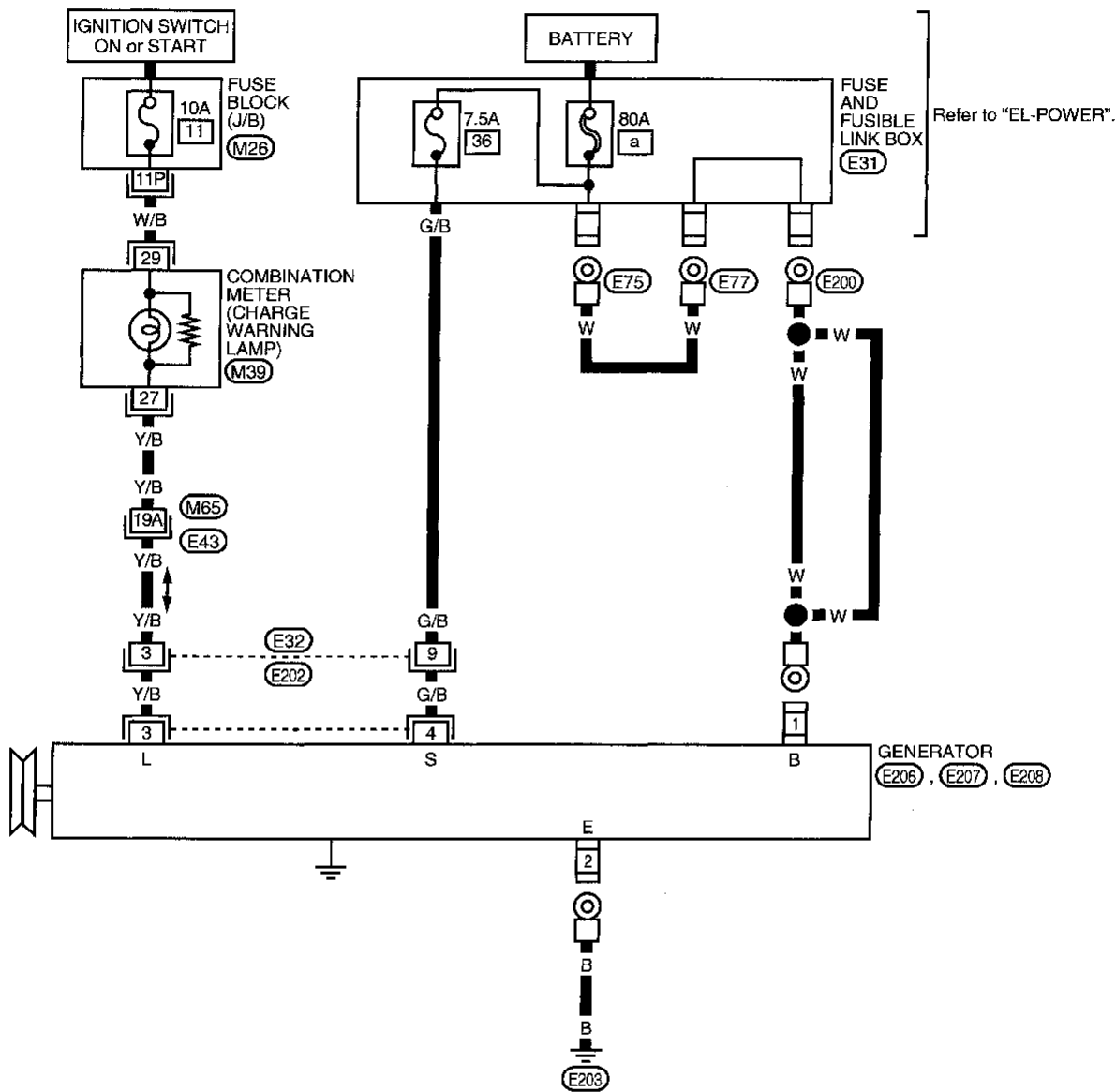

Refer to "EL-POWER".

Refer to last page (Foldout page).

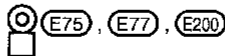
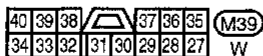
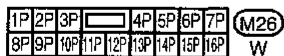

(M65), (E43)
(E31)

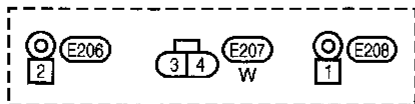

GI
MA
EM
LC
EC
FE
CL
MT
AT
TF
PD
FA
RA
BR
ST
RS
BT
HA
EL
IDX

CHARGING SYSTEM

Trouble Diagnoses

Before conducting a generator test, make sure that the battery is fully charged. A 30-volt voltmeter and suitable test probes are necessary for the test. The generator can be checked easily by referring to the Inspection Table.

- Before starting, inspect the fusible link.
- Use fully charged battery.

WITH IC REGULATOR

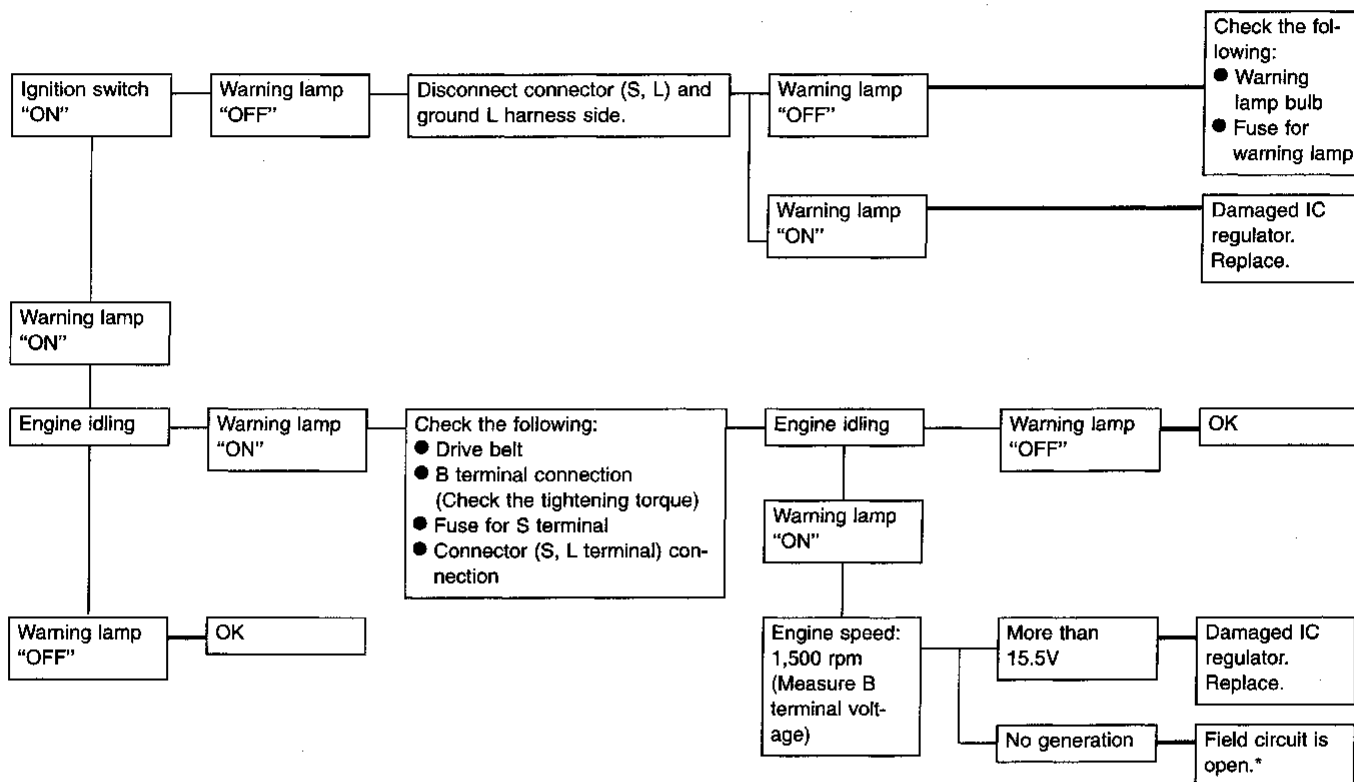

Warning lamp: "CHARGE" warning lamp in combination meter

Note:

★: When field circuit is open, check condition of rotor coil, rotor slip ring and brush. If necessary, replace faulty parts with new ones.

MALFUNCTION INDICATOR

The IC regulator warning function activates to illuminate "CHARGE" warning lamp, if any of the following symptoms occur while generator is operating:

- Excessive voltage is produced.
- No voltage is produced.

Construction

SEC. 231
LR1100-757B

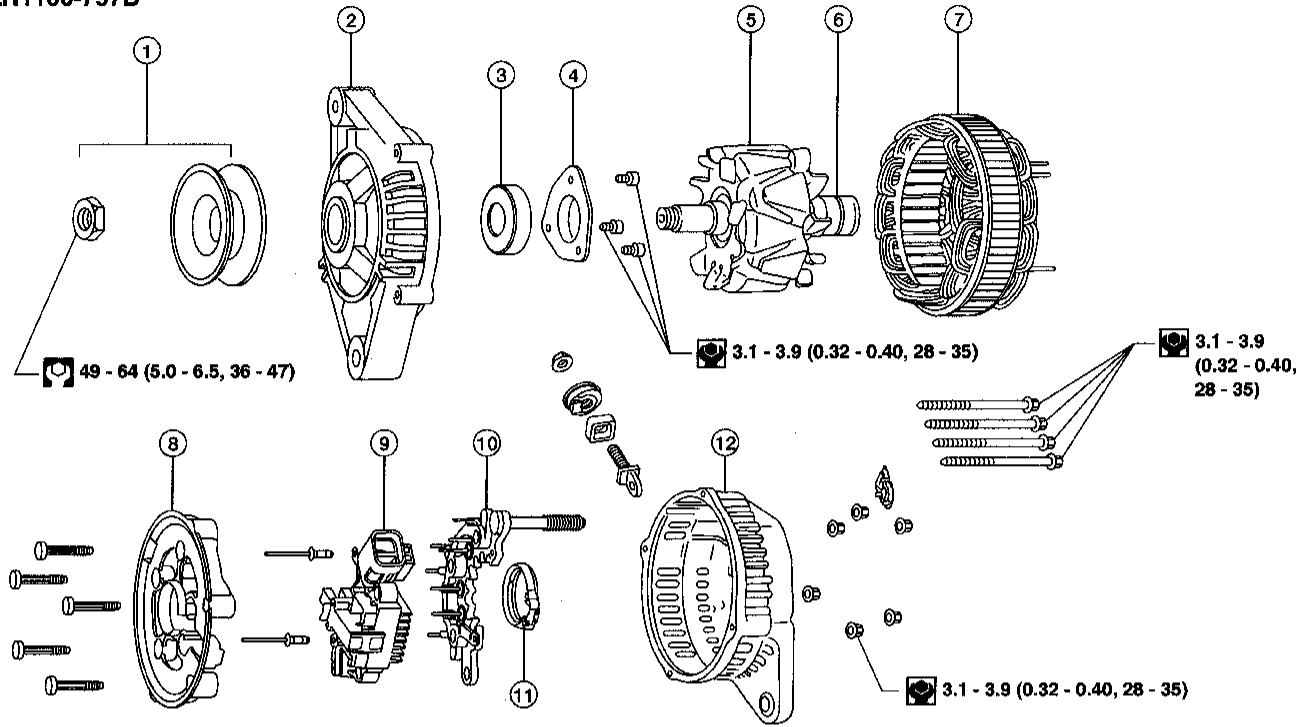

: N·m (kg-m, in-lb)
 : N·m (kg-m, ft-lb)

AEL673B

- ① Pulley assembly
- ② Front cover
- ③ Front bearing
- ④ Retainer

- ⑤ Rotor
- ⑥ Slip ring
- ⑦ Stator
- ⑧ Fan guide

- ⑨ IC regulator assembly
- ⑩ Diode assembly
- ⑪ Packing
- ⑫ Rear cover

GI
MA
EM
LC
EC
FE
CL
MT
AT
TF
PD
FA
RA
BR
ST
RS
BT
HA
EL
IDX

CHARGING SYSTEM

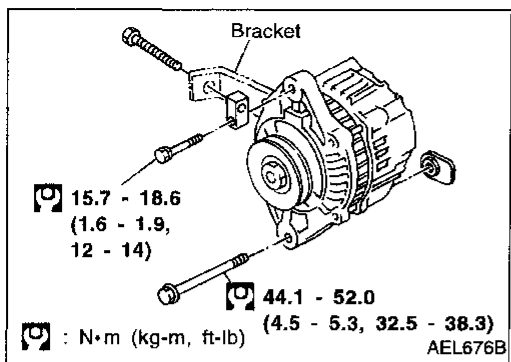

Removal and Installation

REMOVAL

1. Remove engine undercover.
2. Remove side splash shield.
3. Disconnect harness connectors.
4. Back off adjustment bolt, remove belt.
5. Remove two generator bolts and generator.

INSTALLATION

To install, reverse the removal procedure.

Service Data and Specifications (SDS)

GENERATOR

Type		LR1100-757B
		HAP
Nominal rating	V-A	12-70
Ground polarity		Negative
Minimum revolution under no-load (When 13.5 volts is applied)	rpm	Less than 1,000
Hot output current (When 13.5 volts is applied)	A/rpm	More than 17/1,300 More than 54/2,500 More than 72/5,000
Regulated output voltage	V	14.1 - 14.7
Minimum length of brush	mm (in)	6.00 (0.236)
Brush spring pressure	N (g, oz)	1.000 - 2.452 (102 - 250, 3.60 - 8.82)
Slip ring minimum diameter	mm (in)	26.0 (1.024)
Rotor (field coil) resistance	Ω	2.6

COMBINATION SWITCH

Check

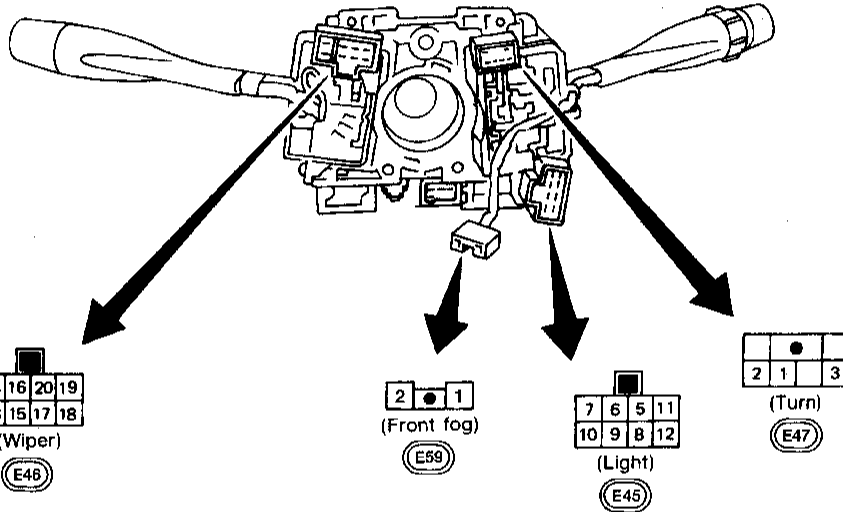
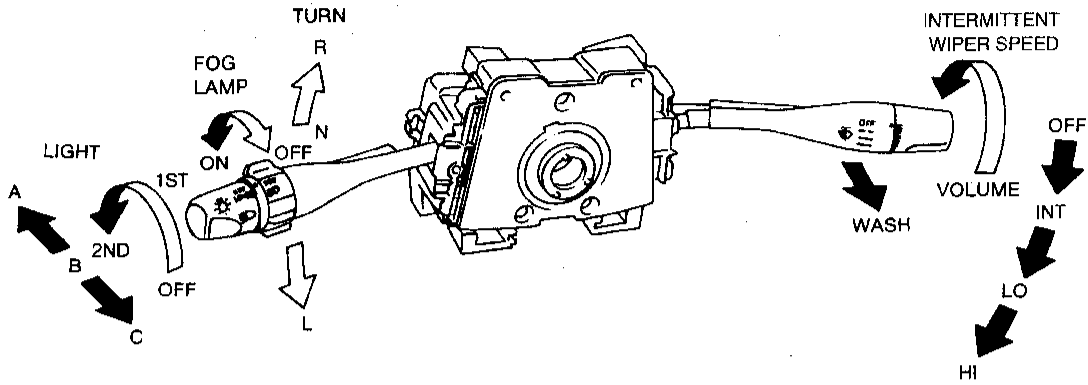

LIGHTING SWITCH

	OFF			1ST			2ND		
	A	B	C	A	B	C	A	B	C
5			○				○	○	○
6			○				○	○	○
7									○
8			○				○	○	○
9			○				○	○	○
10									○
11							○	○	○
12							○	○	○

WIPER SWITCH

	OFF	INT	LO	HI	WASH
	13	○	○		
14	○	○	○		
15		○			
16				○	
17			○	○	○
18					○

INTERMITTENT WIPER VOLUME



TURN SIGNAL SWITCH

	R	N	L
	1	○	
2	○		○
3			○

FRONT FOG LAMP SWITCH

	OFF	ON
	1	○
2		○

GI
MA
EM
LC
EC
FE
CL
MT
AT
TF
PD
FA
RA
BR
ST
RS
BT
HA
EL
IDX

COMBINATION SWITCH

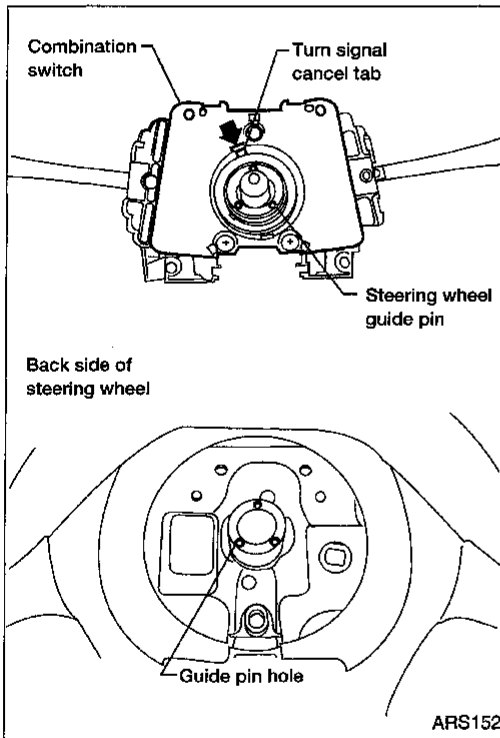
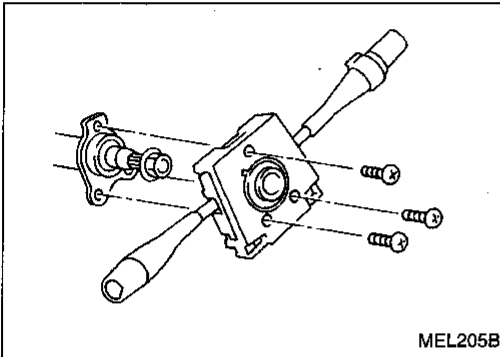
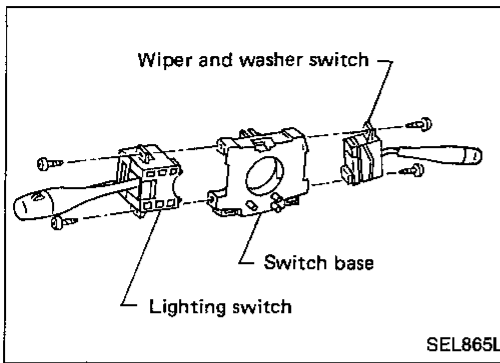

Replacement

For removal and installation of spiral cable, refer to RS section ["Driver Air Bag Module and Spiral Cable", "SUPPLEMENTAL RESTRAINT SYSTEM (SRS)"].

- Each switch can be replaced without removing combination switch base.
- To remove combination switch base, remove base attaching screws.
- Before installing the steering wheel, align the turn signal cancel tab with the notch of combination switch. Refer to RS section ("INSTALLATION", "Driver Air Bag Module and Spiral Cable").

STEERING SWITCH

Check

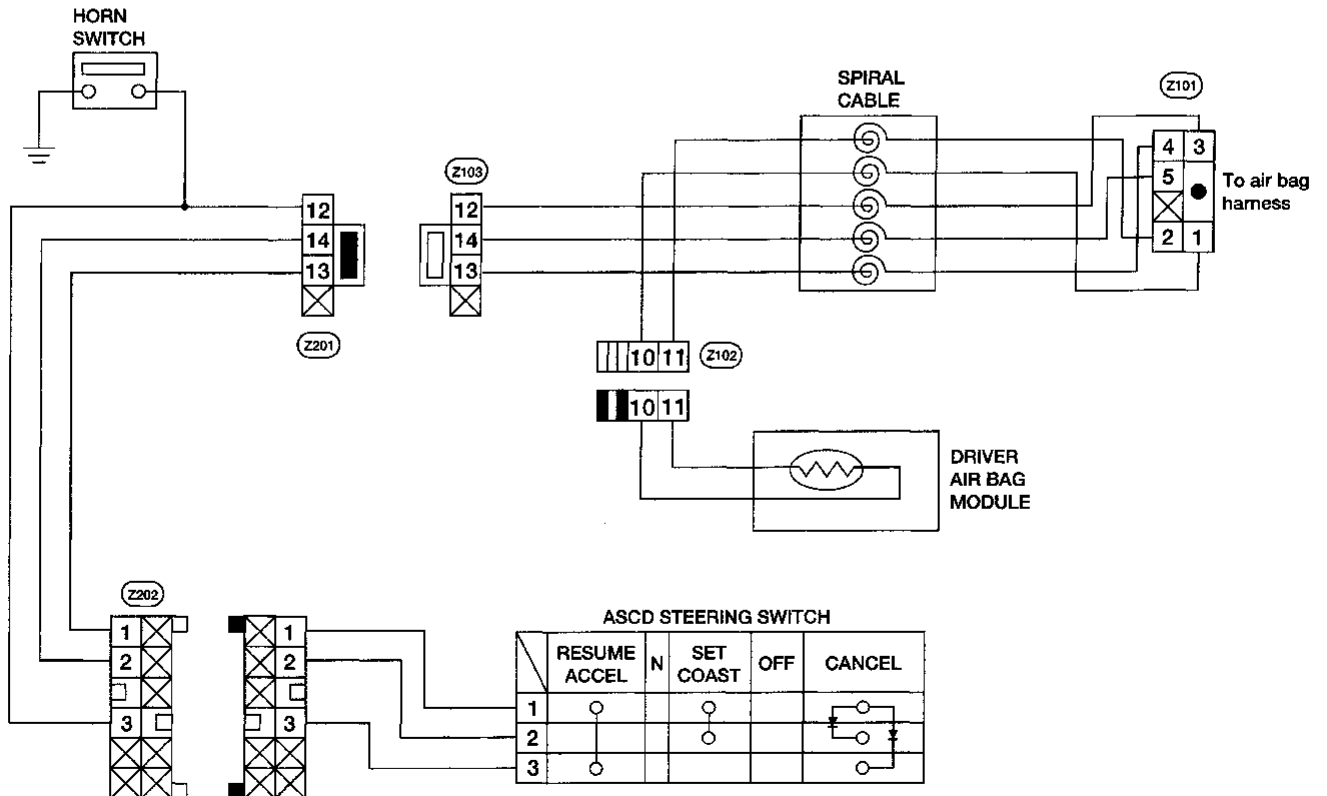
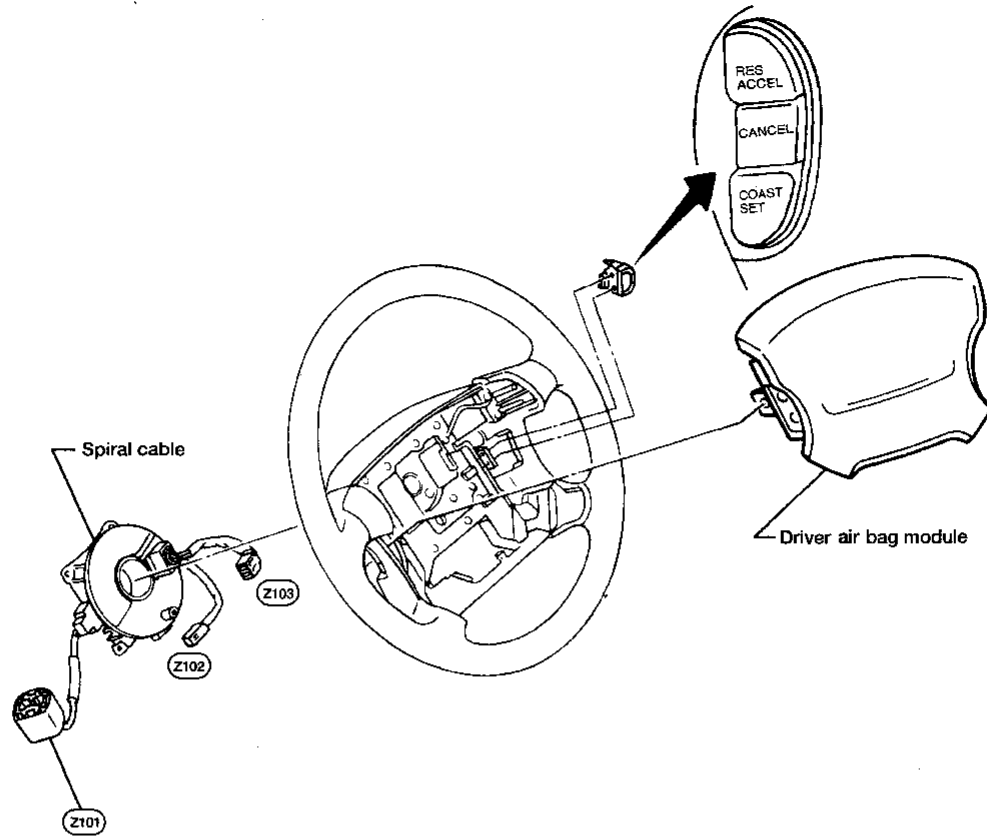

GI
MA
EM
LC
EC
FE
CL
MT
AT
TF
PD
FA
RA
BR
ST
RS
BT
HA
EL
IDX

HEADLAMP

System Description (For USA)

The headlamps are controlled by the lighting switch which is built into the combination switch. Power is supplied at all times:

- to lighting switch terminal (5)
- through 15A fuse (No. 37, located in the fuse and fusible link box), and
- to lighting switch terminal (8)
- through 15A fuse (No. 38, located in the fuse and fusible link box).

Low beam operation

When the lighting switch is turned to headlamp ON (2ND) position, LOW BEAM (B), power is supplied:

- from lighting switch terminal (10)
- to terminal (D) of the LH headlamp, and
- from lighting switch terminal (7)
- to terminal (D) of the RH headlamp.

Terminal (E) of each headlamp supplies ground through body grounds (E12) and (E54).

With power and ground supplied, the headlamp(s) will illuminate.

High beam operation/flash-to-pass operation

When the lighting switch is turned to headlamp ON (2ND) position, HIGH BEAM (A) or FLASH TO PASS (C) position, power is supplied:

- from lighting switch terminal (6)
- to terminal (M) of RH headlamp, and
- from lighting switch terminal (9)
- to terminal (M) of LH headlamp, and
- to combination meter terminal (17) for the high beam indicator.

Ground is supplied to terminal (16) of the combination meter through body grounds (M14) and (M68).

Terminal (E) of each headlamp supplies ground through body grounds (E12) and (E54).

With power and ground supplied, the high beams and the high beam indicator illuminate.

Theft warning system

The theft warning system will flash the high beams if the system is triggered. Refer to "THEFT WARNING SYSTEM" (EL-187).

HEADLAMP

Wiring Diagram (For USA) — H/LAMP —

EL-H/LAMP-01

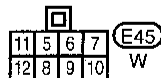
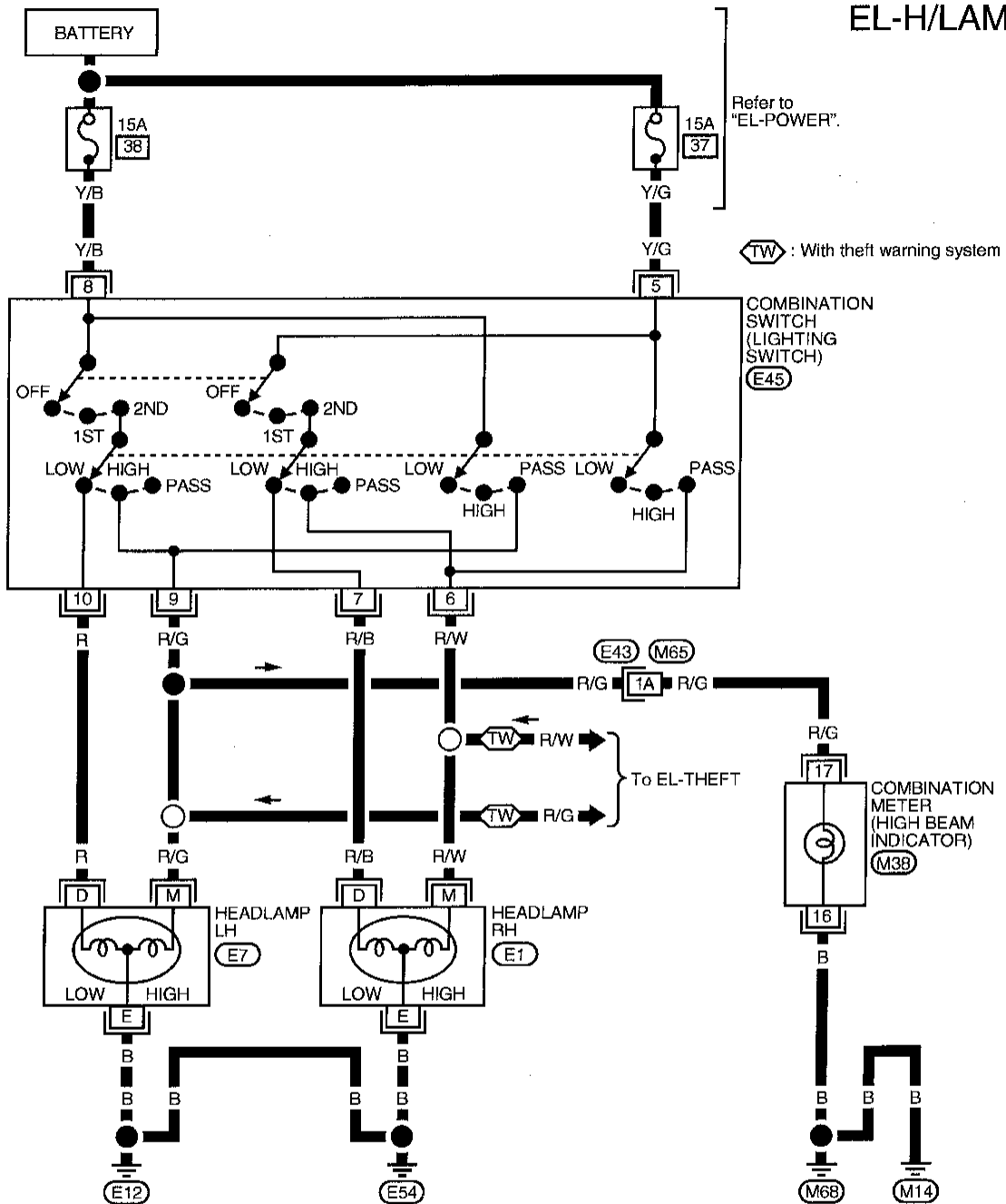

Refer to last page (Foldout page).
 (M65), (E43)

HEADLAMP

Trouble Diagnoses

Symptom	Possible cause	Repair order
LH headlamp does not operate.	<ol style="list-style-type: none"> 1. Bulb 2. Grounds (E12) and (E54) 3. 15A fuse 4. Lighting switch 	<ol style="list-style-type: none"> 1. Check bulb. 2. Check grounds (E12) and (E54). 3. Check 15A fuse (No. 38), located in fuse and fusible link box). Verify battery positive voltage is present at terminal (8) of lighting switch. 4. Check lighting switch.
RH headlamp does not operate.	<ol style="list-style-type: none"> 1. Bulb 2. Grounds (E12) and (E54) 3. 15A fuse 4. Lighting switch 	<ol style="list-style-type: none"> 1. Check bulb. 2. Check grounds (E12) and (E54). 3. Check 15A fuse (No. 37), located in fuse and fusible link box). Verify battery positive voltage is present at terminal (5) of lighting switch. 4. Check lighting switch.
LH high beam does not operate, but LH low beam operates.	<ol style="list-style-type: none"> 1. Bulb 2. Open in LH high beam circuit 3. Lighting switch 	<ol style="list-style-type: none"> 1. Check bulb. 2. Check R/G wire between lighting switch and LH headlamp for an open circuit. 3. Check lighting switch.
LH low beam does not operate, but LH high beam operates.	<ol style="list-style-type: none"> 1. Bulb 2. Open in LH low beam circuit 3. Lighting switch 	<ol style="list-style-type: none"> 1. Check bulb. 2. Check R wire between lighting switch and LH headlamp for an open circuit. 3. Check lighting switch.
RH high beam does not operate, but RH low beam operates.	<ol style="list-style-type: none"> 1. Bulb 2. Open in RH high beam circuit 3. Lighting switch 	<ol style="list-style-type: none"> 1. Check bulb. 2. Check R/W wire between lighting switch and RH headlamp for an open circuit. 3. Check lighting switch.
RH low beam does not operate, but RH high beam operates.	<ol style="list-style-type: none"> 1. Bulb 2. Open in RH low beam circuit 3. Lighting switch 	<ol style="list-style-type: none"> 1. Check bulb. 2. Check R/B wire between lighting switch and RH headlamp for an open circuit. 3. Check lighting switch.
High beam indicator does not work.	<ol style="list-style-type: none"> 1. Bulb 2. Grounds (M14) and (M68) 3. Open in high beam circuit 	<ol style="list-style-type: none"> 1. Check bulb in combination meter. 2. Check grounds (M14) and (M68). 3. Check R/G wire between lighting switch and combination meter for an open circuit.

HEADLAMP

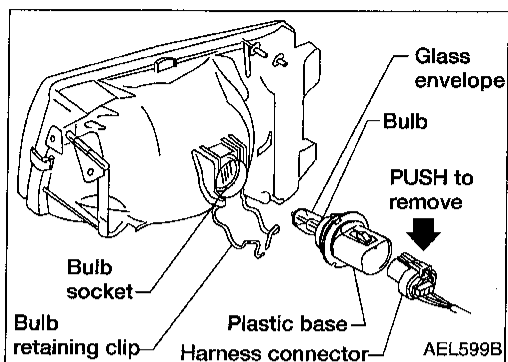

Bulb Replacement

The headlamp is a semi-sealed beam type which uses a replaceable halogen bulb. The bulb can be replaced from the engine compartment side without removing the headlamp body.

- **Grasp only the plastic base when handling the bulb. Never touch the glass envelope.**
1. Disconnect the battery cable.
 2. Disconnect the harness connector from the back side of the bulb.
 3. Unclip the bulb retaining clip, and then remove it.
 4. Remove the headlamp bulb carefully. Do not shake or rotate the bulb when removing it.
 5. Install in the reverse order of removal.

CAUTION:

- **Do not leave headlamp reflector without bulb for a long period of time. Dust, moisture, smoke, etc. entering headlamp body may affect the performance of the headlamp. Remove headlamp bulb from the headlamp reflector just before a replacement bulb is installed.**

Aiming Adjustment

When performing headlamp aiming adjustment, use an aiming machine, aiming wall screen or headlamp tester. Aimers should be in good repair, calibrated and operated in accordance with respective operation manuals.

If any aimer is not available, aiming adjustment can be done as follows:

For details, refer to the regulations in your own country.

- a. **Keep all tires inflated to correct pressures.**
- b. **Place vehicle and tester on one and same flat surface.**
- c. **See that there is no-load in vehicle (coolant, engine oil filled up to correct level and full fuel tank) other than the driver (or equivalent weight placed in driver's position).**

GI

MA

EM

LC

EC

FE

CL

MT

AT

TF

PD

FA

RA

BR

ST

RS

BT

HA

EL

IDX

HEADLAMP

Aiming Adjustment (Cont'd)

AIMER ADJUSTMENT MARK

When using a mechanical aimer, adjust adapter legs to the data marked on the headlamps.

Adjustment value for mechanical aimer

	Mechanical aimer level
Horizontal side	-4 to 4
Vertical side	-4 to 4

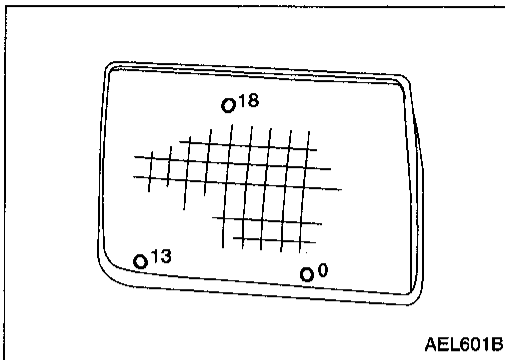

AEL601B

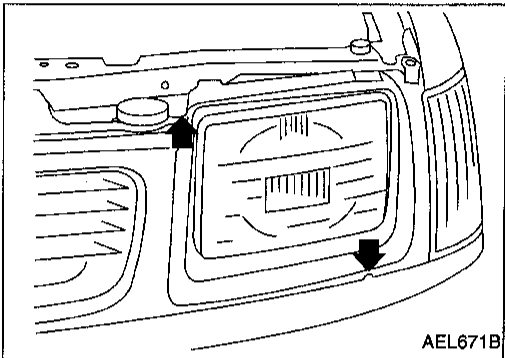

AEL671B

LOW BEAM

1. Turn headlamp low beam on.
 2. Use a #2 cross-recessed screwdriver to adjust the aim of the lamp.
- **Cover the opposite lamp.**

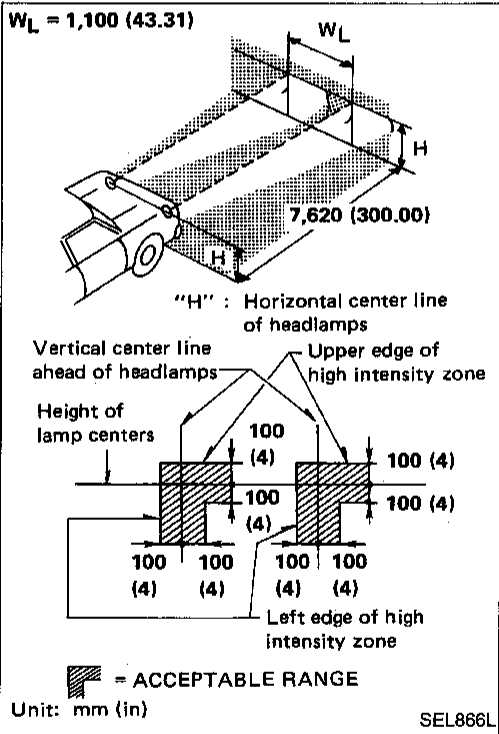

SEL866L

If the vehicle front body has been repaired and/or the headlamp assembly has been replaced, check aiming. Use the aiming chart shown in the figure.

- **Upper edge and left edge of high intensity zone should be within the range shown at left. Adjust headlamps accordingly.**
- **Dotted lines in illustration show center of headlamp.**

"H": Horizontal center line of headlamps

"WL": Distance between each headlamp center

HEADLAMP

NOTES

GI

MA

EM

LC

EC

FE

CL

MT

AT

TF

PD

FA

RA

BR

ST

RS

BT

HA

EL

IDX

System Description (For Canada)

The headlamp system for Canada vehicles contains a daytime light control unit that activates the high beam headlamps at approximately half illumination whenever the engine is running. If the parking brake is applied before the engine is started the daytime lights will not be illuminated. The daytime lights will illuminate once the parking brake is released. Thereafter, the daytime lights will continue to operate when the parking brake is applied. If the daytime light control unit receives a ground signal from the generator, the daytime lights will not be illuminated. The daytime lights will illuminate once a battery positive voltage signal is sent to the daytime light control unit from the generator.

Power is supplied at all times:

- through 15A fuse (No. 38, located in the fuse and fusible link box)
- to daytime light control unit terminal ③ and
- to lighting switch terminal ⑧.

Power is also supplied at all times:

- through 15A fuse (No. 37, located in the fuse and fusible link box)
- to daytime light control unit terminal ② and
- to lighting switch terminal ⑤.

With the ignition switch in the ON or START position, power is supplied:

- through 7.5A fuse [No. 5, located in the fuse block (J/B)]
- to daytime light control unit terminal ⑫.

With the ignition switch in the START position, power is supplied:

- through 7.5A fuse [No. 7, located in the fuse block (J/B)]
- to daytime light control unit terminal ①.

Ground is supplied to daytime light control unit terminal ⑨ through body grounds E12 and E54.

HEADLAMP OPERATION

Low beam operation

When the lighting switch is turned to headlamp ON (2ND) position, LOW BEAM (B), power is supplied:

- from lighting switch terminal ⑦
- to RH headlamp terminal D
- to daytime light control unit terminal ④.

Ground is supplied to RH headlamp terminal E through body grounds E12 and E54.

Also, when the lighting switch is turned to headlamp ON (2ND) position, LOW BEAM (B), power is supplied:

- from lighting switch terminal ⑩
- to LH headlamp terminal D.

Ground is supplied:

- to LH headlamp terminal E
- from daytime light control unit terminal ⑦
- through daytime light control unit terminal ⑨
- through body grounds E12 and E54.

With power and ground supplied, the low beam headlamps illuminate.

High beam operation/flash-to-pass operation

When the lighting switch is turned to headlamp ON (2ND) position, HIGH BEAM (A) or FLASH TO PASS (C) position, power is supplied:

- from lighting switch terminal ⑥
- to terminal M of RH headlamp.

When the lighting switch is turned to headlamp ON (2ND) position, HIGH BEAM (A) or FLASH TO PASS (C) position, power is supplied:

- from lighting switch terminal ⑨
- to daytime light control terminal ⑤
- to combination meter terminal ⑰ for the high beam indicator
- through daytime light control terminal ⑥
- to terminal M of LH headlamp.

Ground is supplied in the same manner as low beam operation.

Ground is supplied to terminal ⑱ of the combination meter through body grounds M14 and M68.

With power and ground supplied, the high beam headlamps and HI BEAM indicator illuminate.

HEADLAMP — Daytime Light System —

System Description (For Canada) (Cont'd)

DAYTIME LIGHT OPERATION

With the engine running, the lighting switch in the OFF or parking lamp (1ST) position and parking brake released, power is supplied:

- to daytime light control unit terminal ③
- through daytime light control unit terminal ⑥
- to terminal ④ of LH headlamp
- through terminal ⑤ of LH headlamp
- to daytime light control unit terminal ⑦
- through daytime light control unit terminal ⑧
- to terminal ④ of RH headlamp.

Ground is supplied to terminal ⑤ of RH headlamp through body grounds ①E12 and ①E54. Because the high beam headlamps are now wired in series, they operate at half illumination.

Operation (For Canada)

After starting the engine with the lighting switch in the OFF or parking lamp (1ST) position, the headlamp high beam automatically turns on. Lighting switch operations other than the above are the same as conventional light systems.

Engine		With engine stopped									With engine running								
		OFF			1ST			2ND			OFF			1ST			2ND		
		A	B	C	A	B	C	A	B	C	A	B	C	A	B	C	A	B	C
Headlamp	High beam	X	X	○	X	X	○	○	X	○	△*	△*	○	△*	△*	○	○	X	○
	Low beam	X	X	X	X	X	X	X	○	X	X	X	X	X	X	X	X	○	X
Parking and tail lamp		X	X	X	○	○	○	○	○	○	X	X	X	○	○	○	○	○	○
License and instrument illumination lamp		X	X	X	○	○	○	○	○	○	X	X	X	○	○	○	○	○	○

- A : HIGH BEAM position
- B : LOW BEAM position
- C : FLASH TO PASS position
- : Lamp ON
- X : Lamp OFF
- △ : Lamp dims.
- : Added functions

*: When starting the engine with the parking brake released, the daytime light will come ON.
 When starting the engine with the parking brake pulled, the daytime light won't come ON.

GI
MA
EM
LC
EC
FE
CL
MT
AT
TF
PD
FA
RA
BR
ST
RS
BT
HA
EL
IDX

HEADLAMP — Daytime Light System —

Schematic (For Canada)

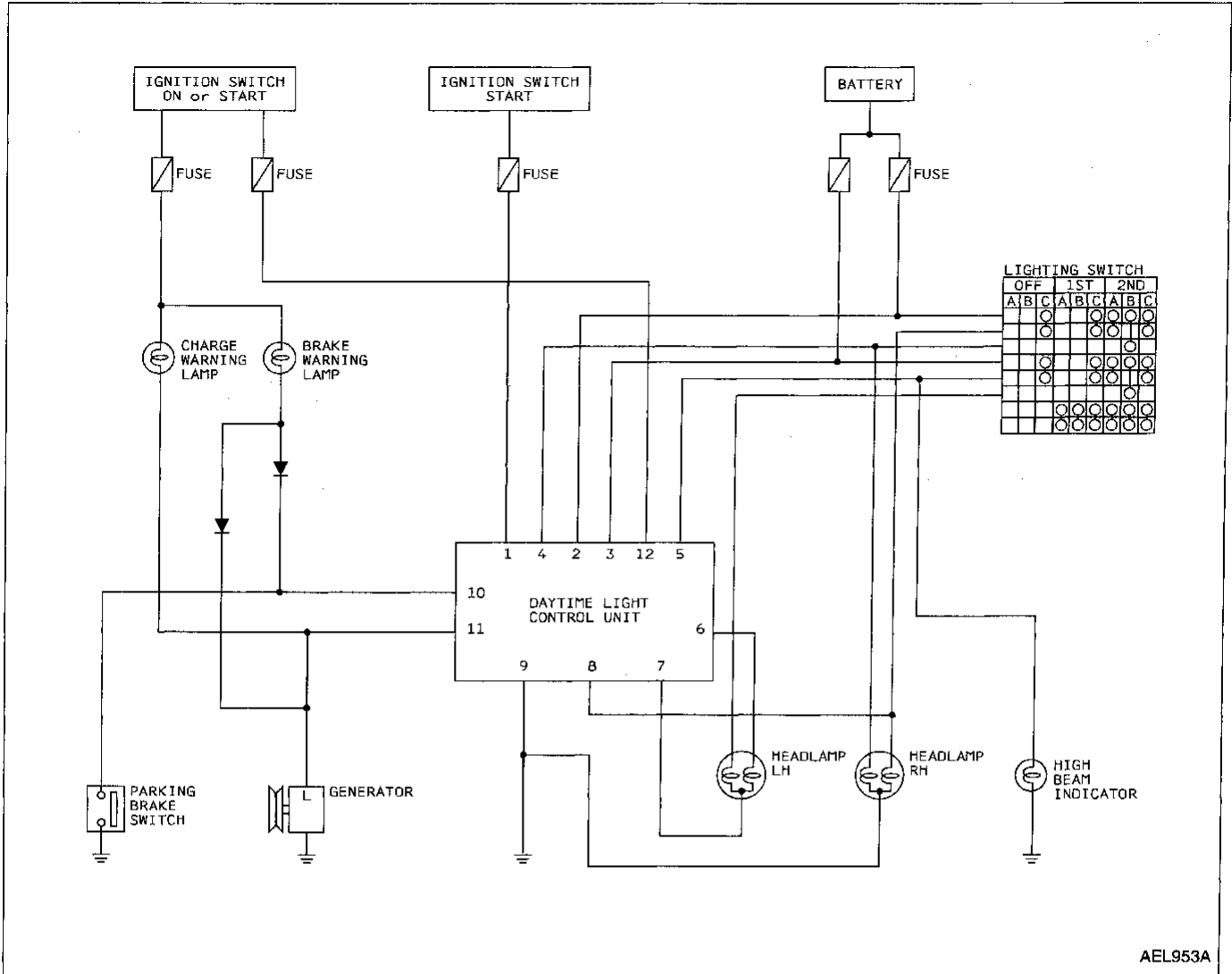

AEL953A

HEADLAMP — Daytime Light System —

Wiring Diagram (For Canada) — DTRL —

EL-DTRL-01

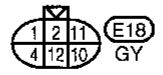
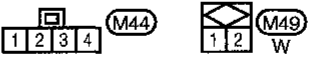
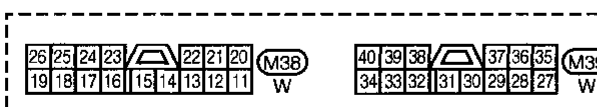
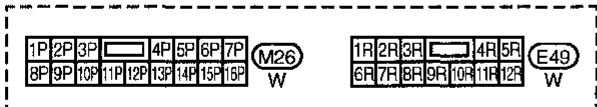
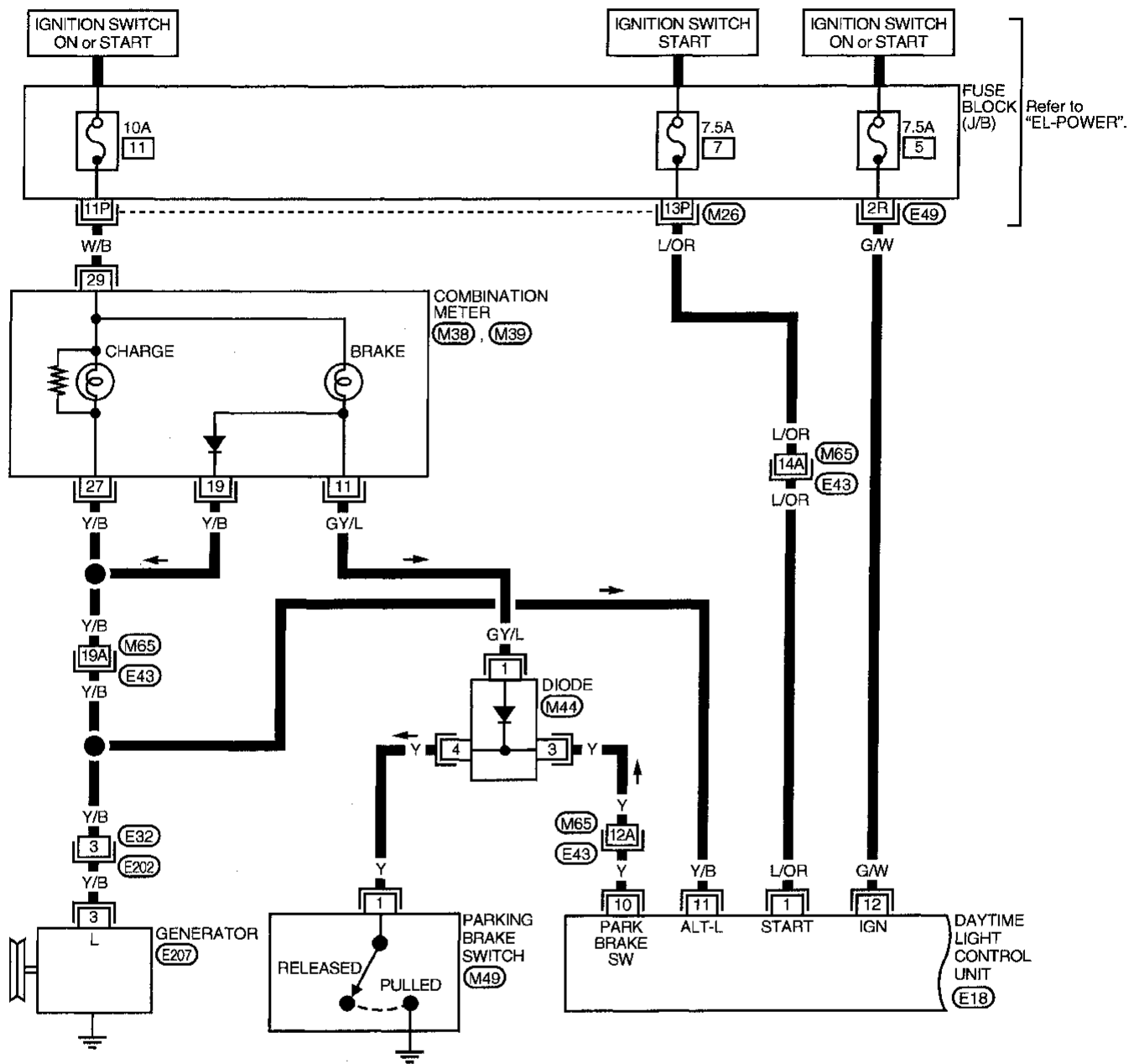

Refer to last page (Foldout page).

M65, E43

GI
MA
EM
LC
EC
FE
CL
MT
AT
TF
PD
FA
RA
BR
ST
RS
BT
HA
EL
IDX

HEADLAMP — Daytime Light System —

Wiring Diagram (For Canada) — DTRL — (Cont'd)

EL-DTRL-02

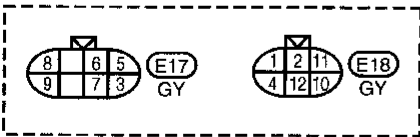
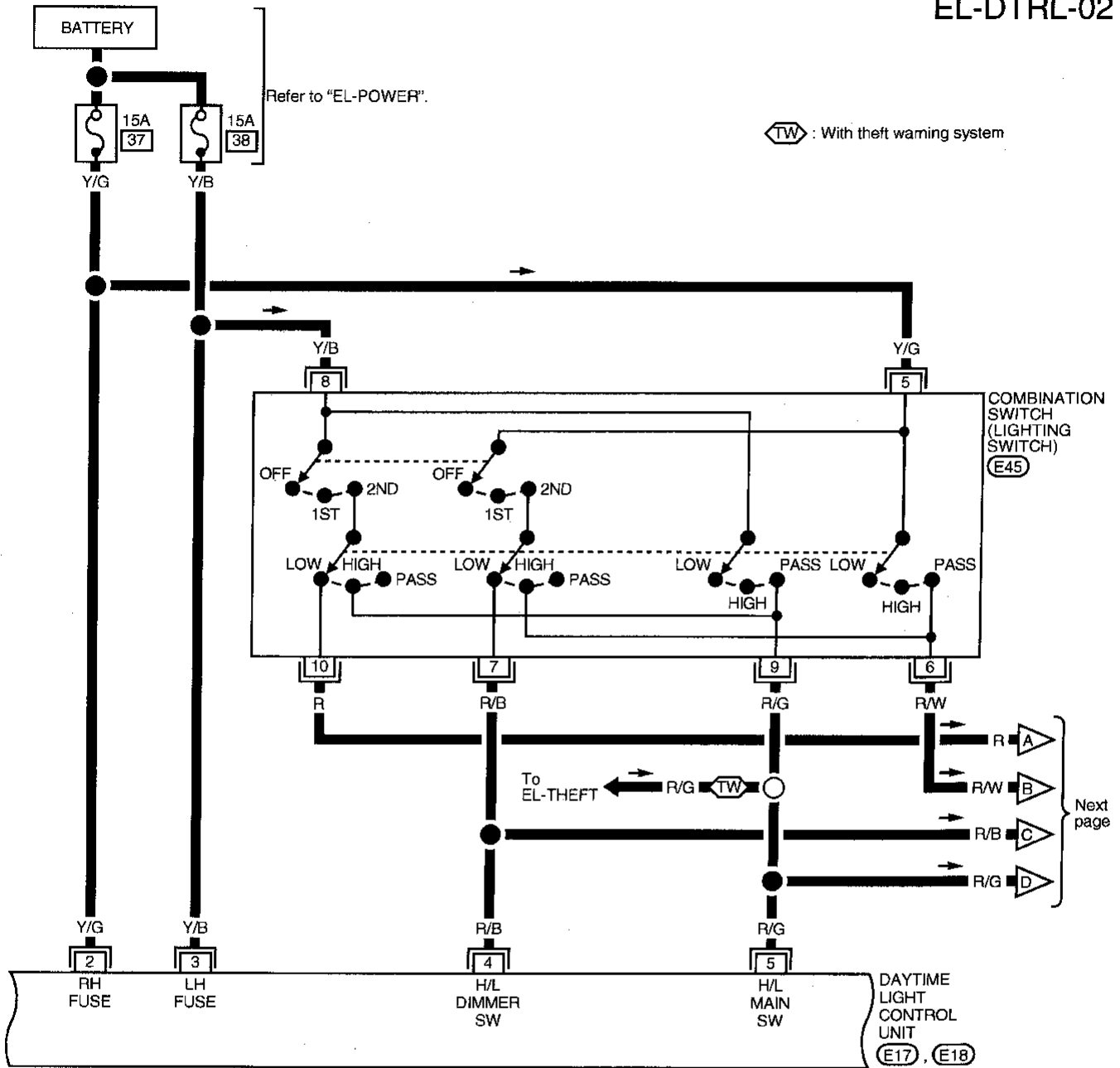

HEADLAMP — Daytime Light System —

Wiring Diagram (For Canada) — DTRL — (Cont'd)

EL-DTRL-03

 : With theft warning system

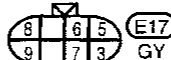
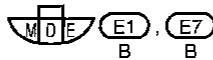
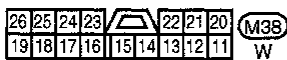
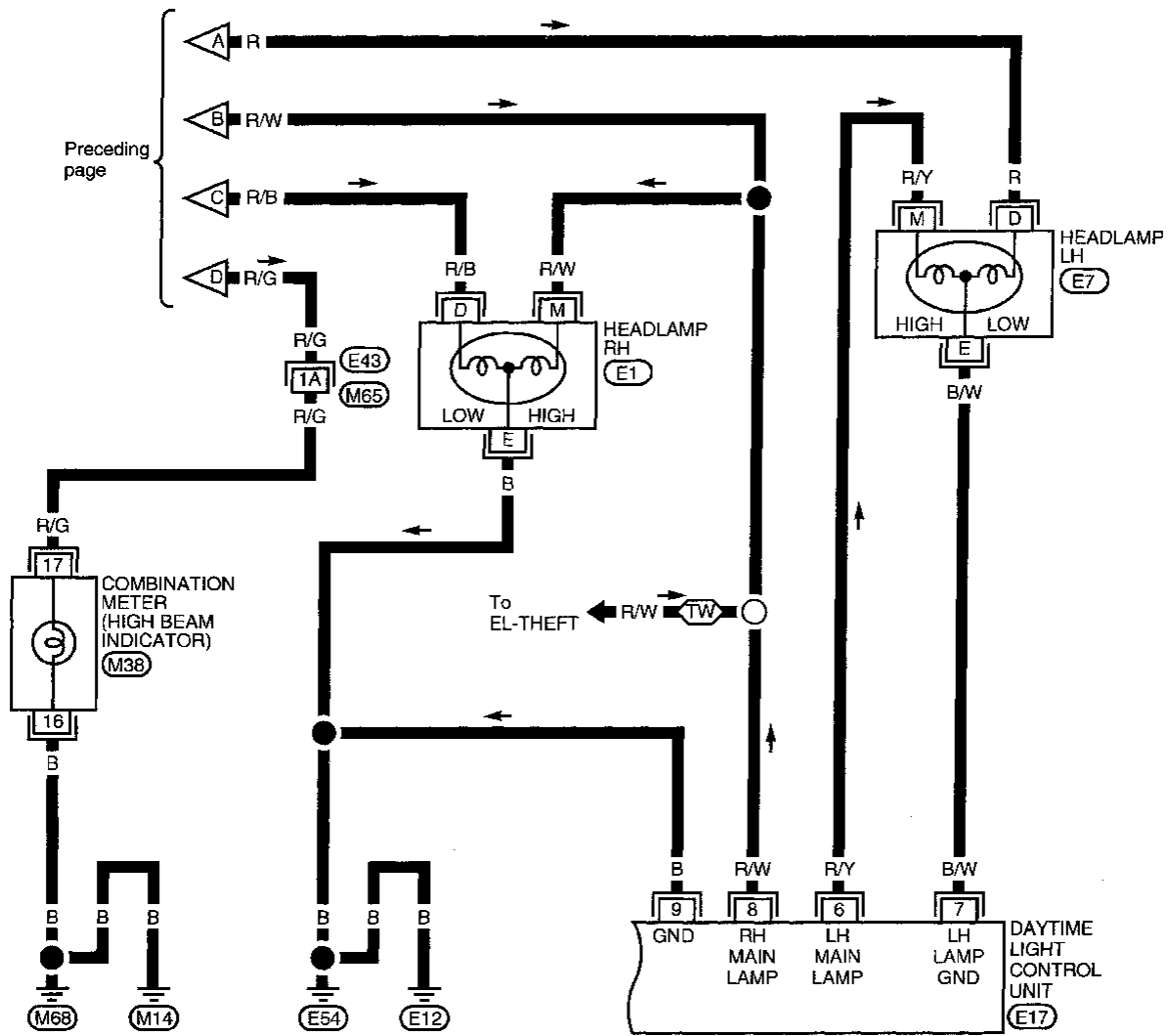

Refer to last page (Foldout page).









(M65), (E43)

GI
MA
EM
LC
EC
FE
CL
MT
AT
TF
PD
FA
RA
BR
ST
RS
BT
HA
EL
IDX

HEADLAMP — Daytime Light System —





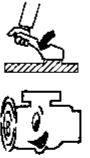
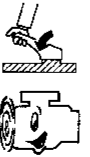



Trouble Diagnoses (For Canada)

DAYTIME LIGHT CONTROL UNIT INSPECTION TABLE

Terminal No.	Wire color	Item	Condition		Voltage (Approximate values)
1	L/OR	Start signal		When turning ignition switch to ST	Battery voltage
				When turning ignition switch to ON from ST	Less than 1V
				When turning ignition switch to OFF	Less than 1V
2	Y/G	Power source		When turning ignition switch to ON	Battery voltage
				When turning ignition switch to OFF	Battery voltage
3	Y/B	Power source		When turning ignition switch to ON	Battery voltage
				When turning ignition switch to OFF	Battery voltage
4	R/B	Lighting switch (Lo beam)		When turning lighting switch to headlamp ON (2ND) position, LOW BEAM	Battery voltage
5	R/G	Lighting switch (Hi beam)		When turning lighting switch to HI BEAM	Battery voltage
				When turning lighting switch to FLASH TO PASS	Battery voltage
6	R/Y	LH hi beam		When turning lighting switch to HI BEAM	Battery voltage
				When releasing parking brake with engine running and turning lighting switch to OFF (daytime light operation) CAUTION: Block wheels and ensure selector lever is in N or P position.	Battery voltage
7	B/W	LH headlamp control (ground)		When lighting switch is turned to headlamp ON (2ND) position, LOW BEAM	Less than 1V
				When releasing parking brake with engine running and turning lighting switch to OFF (daytime light operation) CAUTION: Block wheels and ensure selector lever is in N or P position.	Approx. half battery voltage
8	R/W	RH hi beam		When turning lighting switch to HI BEAM	Battery voltage
				When releasing parking brake with engine running and turning lighting switch to OFF (daytime light operation) CAUTION: Block wheels and ensure selector lever is in N or P position.	Approx. half battery voltage
9	B	Ground		—	—

HEADLAMP — Daytime Light System —

Trouble Diagnoses (For Canada) (Cont'd)

Terminal No.	Wire color	Item	Condition		Voltage (Approximate values)
10	Y	Parking brake switch		When parking brake is released	Battery voltage
				When parking brake is set	Less than 1.5V
11	Y/B	Generator		When turning ignition switch to ON	Less than 1V
				When engine is running	Battery voltage
				When turning ignition switch to OFF	Less than 1V
12	G/W	Power source		When turning ignition switch to ON	Battery voltage
				When turning ignition switch to ST	Battery voltage
				When turning ignition switch to OFF	Less than 1V

Bulb Replacement

Refer to "HEADLAMP" (EL-45).

Aiming Adjustment

Refer to "HEADLAMP" (EL-45).

GI
MA
EM
LC
EC
FE
CL
MT
AT
TF
PD
FA
RA
BR
ST
RS
BT
HA
EL
IDX

PARKING, LICENSE AND TAIL LAMPS

Wiring Diagram — TAIL/L —

EL-TAIL/L-01

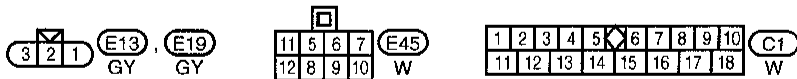
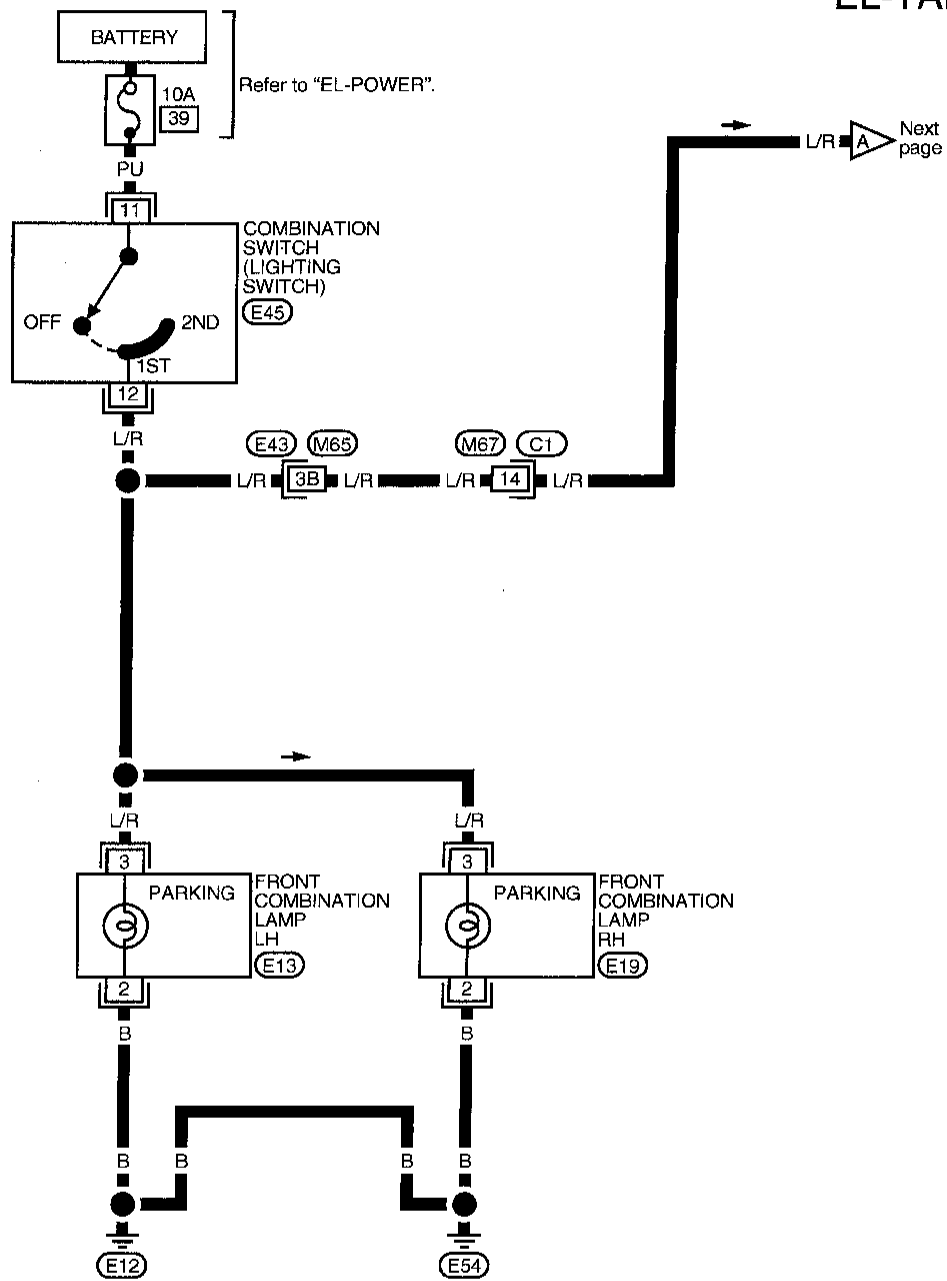

Refer to last page (Foldout page).

(M65), (E43)

PARKING, LICENSE AND TAIL LAMPS

Wiring Diagram — TAIL/L — (Cont'd)

EL-TAIL/L-02

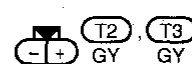
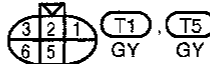
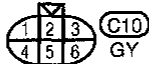
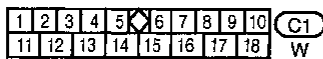
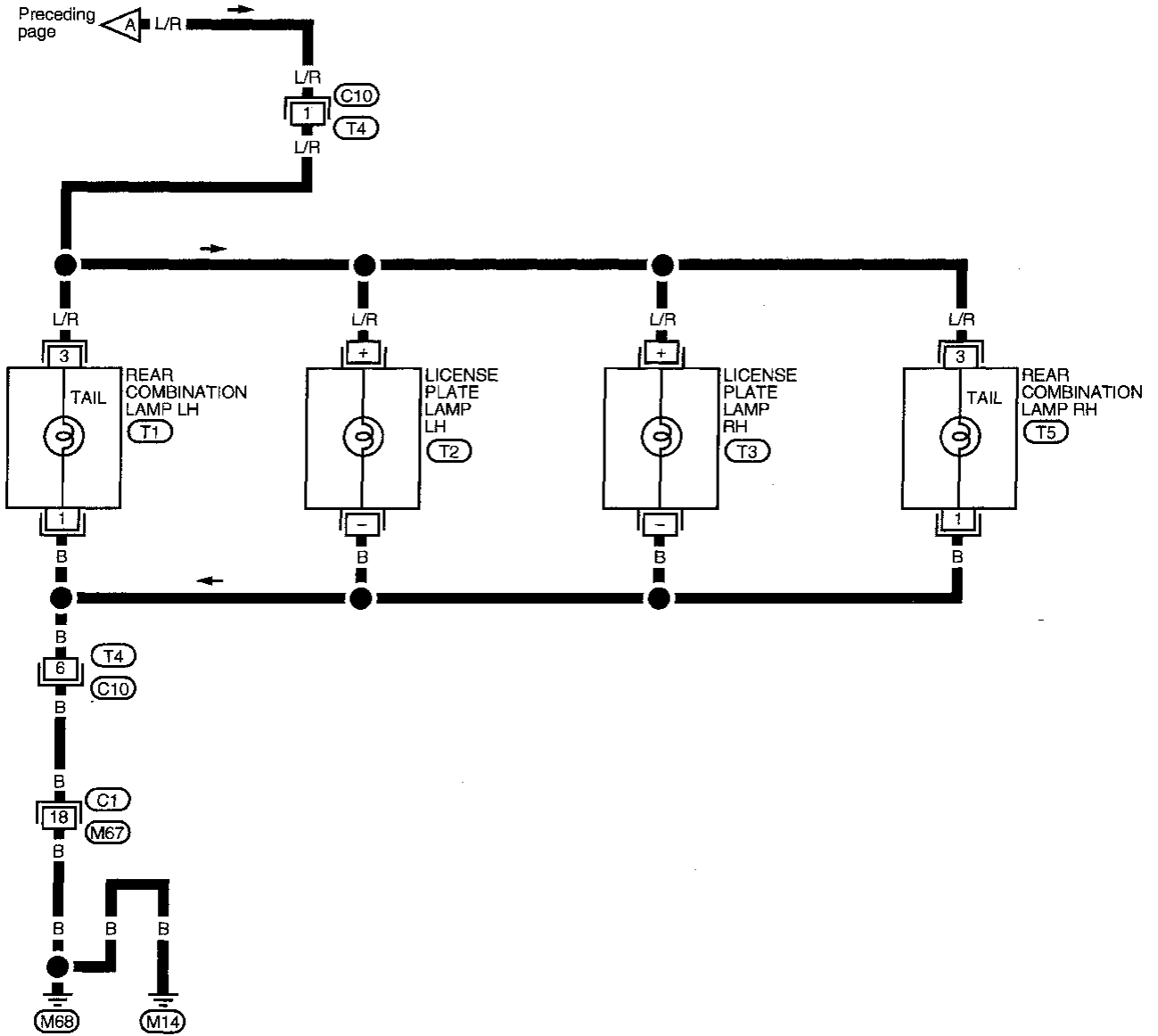

GI
MA
EM
LC
EC
FE
CL
MT
AT
TF
PD
FA
RA
BR
ST
RS
BT
HA
EL
IDX

STOP LAMP

Wiring Diagram — STOP/L —

EL-STOP/L-01

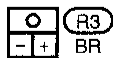
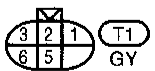
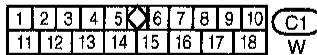
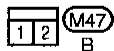
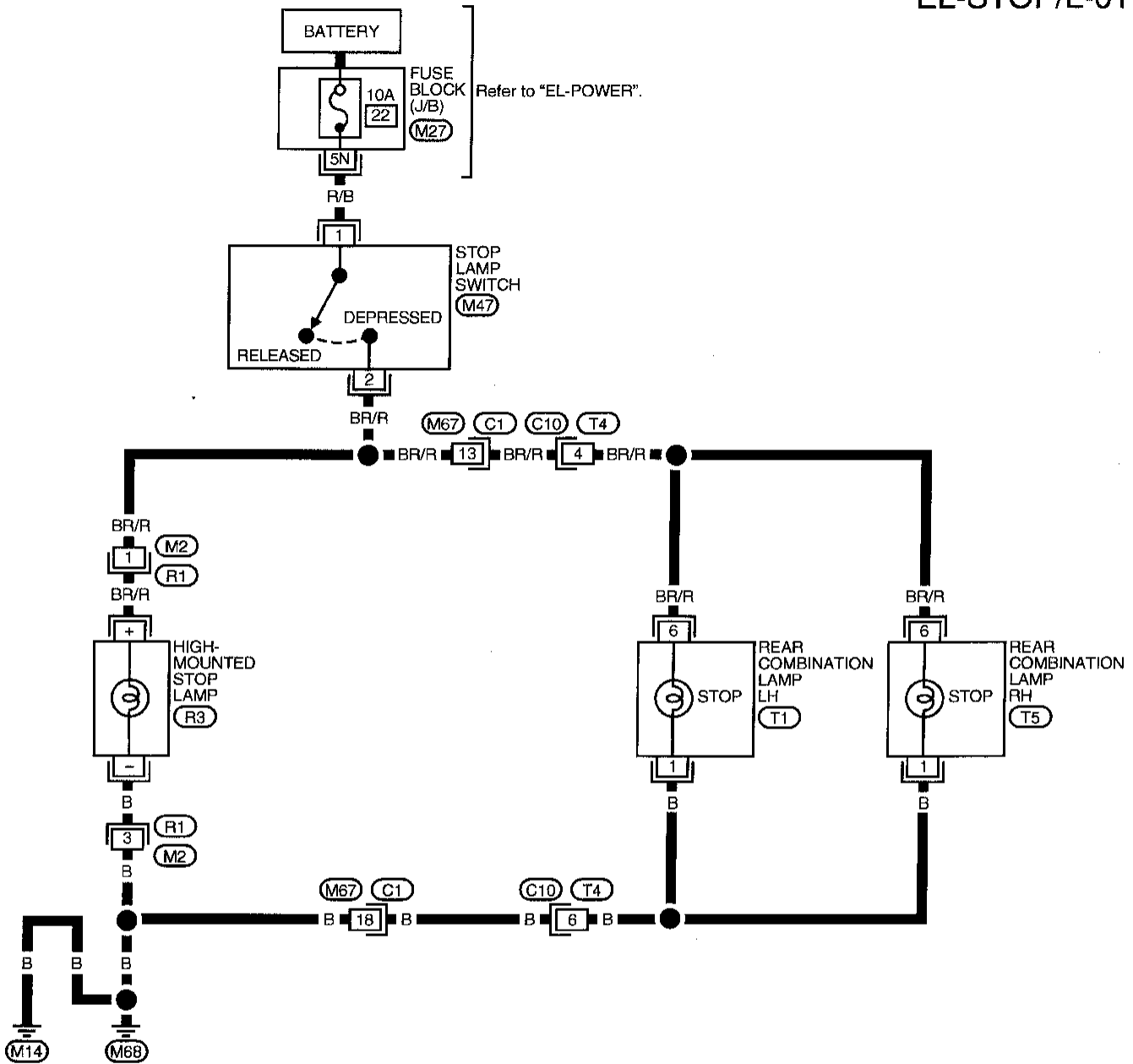

BACK-UP LAMP

Wiring Diagram — BACK/L —

EL-BACK/L-01

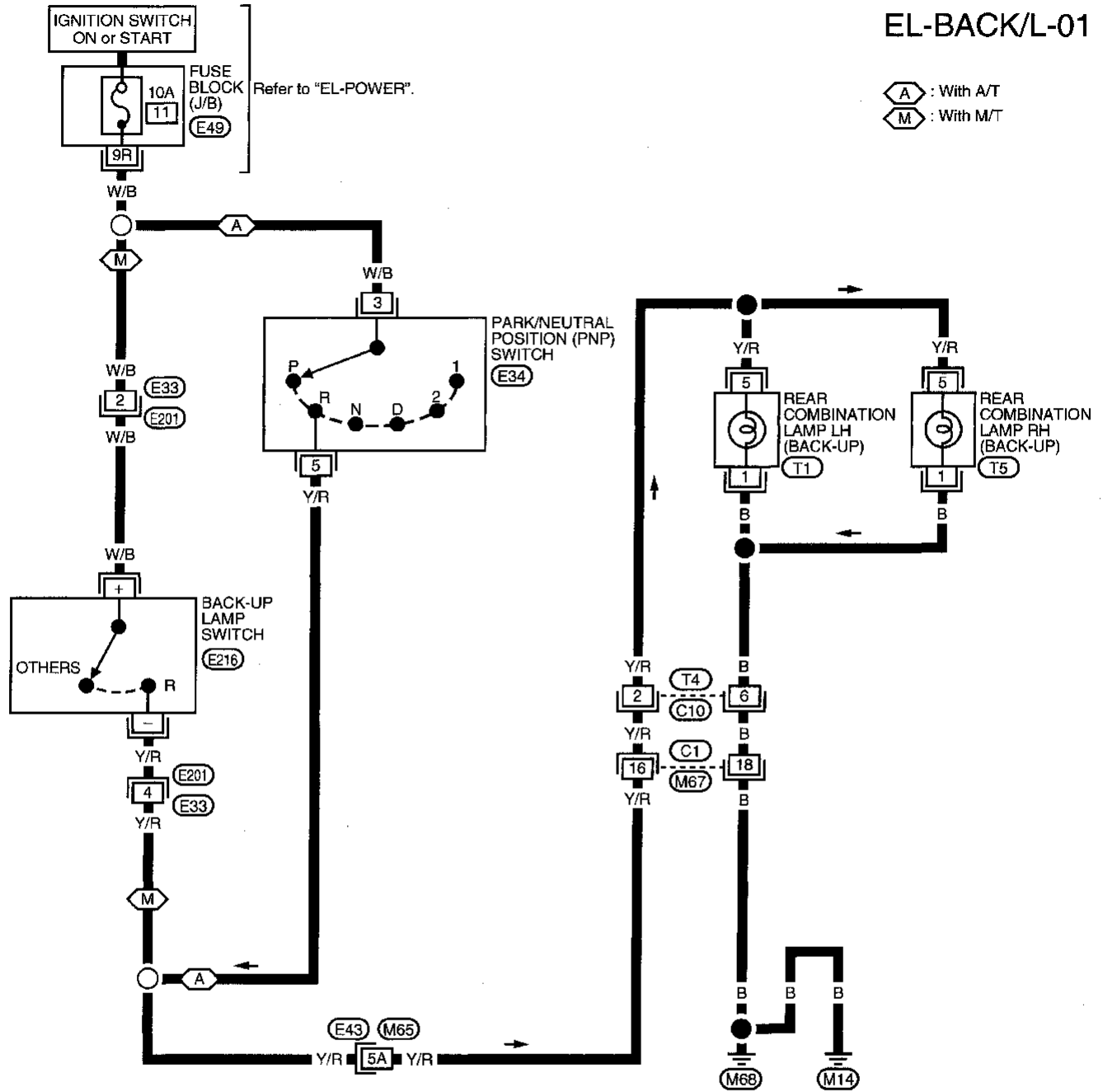

Refer to last page (Foldout page).

(M65) (E43)

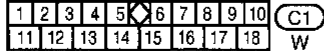
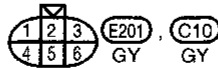

GI
MA
EM
LC
EC
FE
CL
MT
AT
TF
PD
FA
RA
BR
ST
RS
BT
HA
EL
IDX

FRONT FOG LAMP

System Description

Power is supplied at all times to front fog lamp relay terminal ⑤ through:

- 15A fuse (No. ④⑩, located in the fuse and fusible link box).

With the lighting switch in headlamp ON (2ND) position, LOW BEAM (B), power is supplied:

- through 15A fuse (No. ③⑦, located in the fuse and fusible link box)
- to lighting switch terminal ⑤
- through terminal ⑦ of the lighting switch
- to front fog lamp relay terminal ②.

Fog lamp operation

The fog lamp switch is built into the combination switch. The lighting switch must be in headlamp ON (2ND) position, LOW BEAM (B) for fog lamp operation.

With the front fog lamp switch in the ON position:

- ground is supplied to front fog lamp relay terminal ① through the front fog lamp switch and body grounds ①② and ①④.

The fog lamp relay is energized and power is supplied:

- from front fog lamp relay terminal ③
- to terminal ① of each front fog lamp.

Ground is supplied to terminal ② of each front fog lamp through body grounds ①② and ①④.

With power and ground supplied, the front fog lamps illuminate.

FRONT FOG LAMP

Wiring Diagram — F/FOG —

EL-F/FOG-01

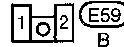
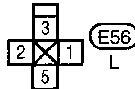
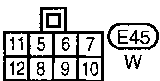
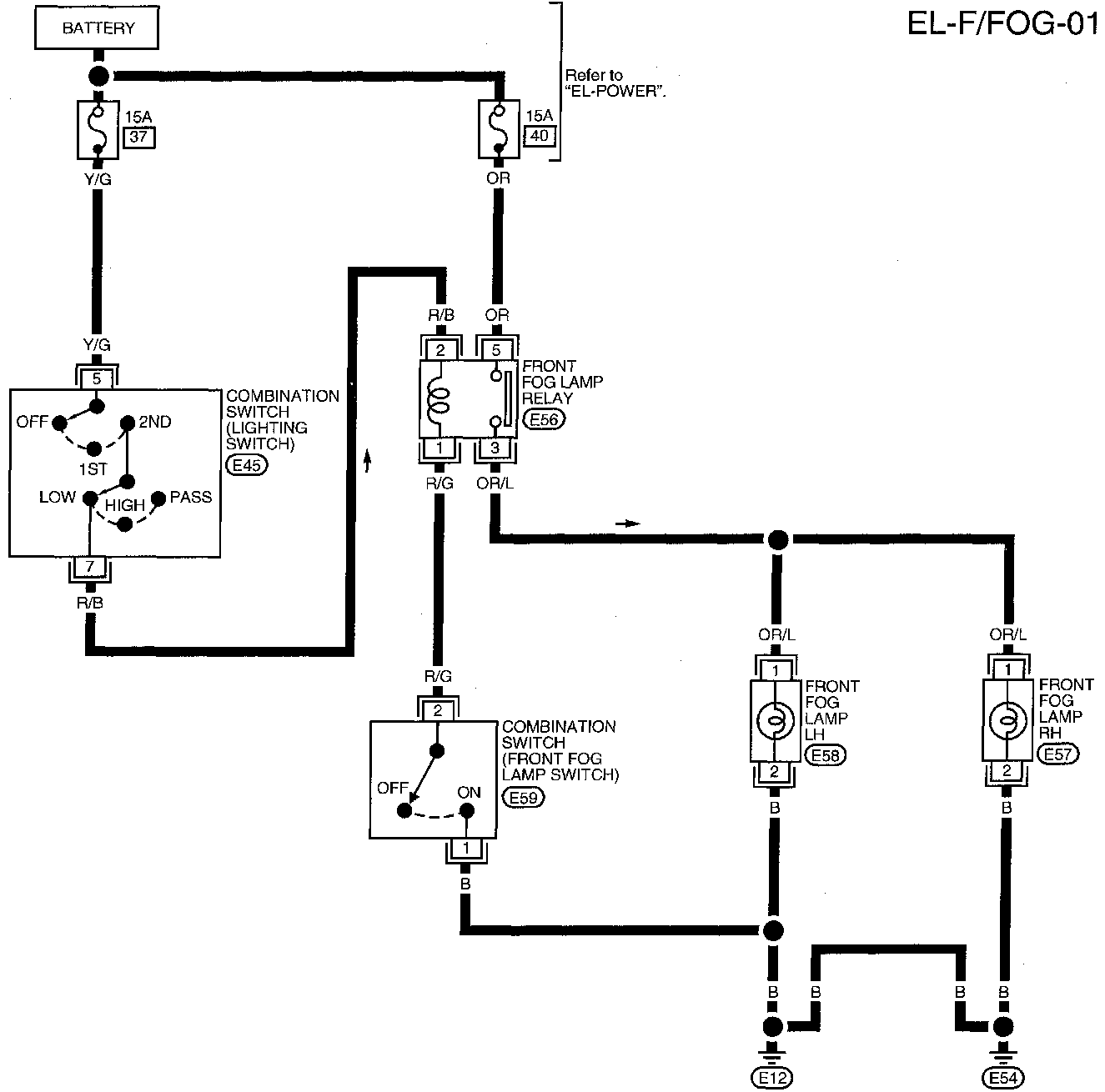

GI
MA
EM
LC
EC
FE
CL
MT
AT
TF
PD
FA
RA
BR
ST
RS
BT
HA
EL
IDX

FRONT FOG LAMP

View from under vehicle.

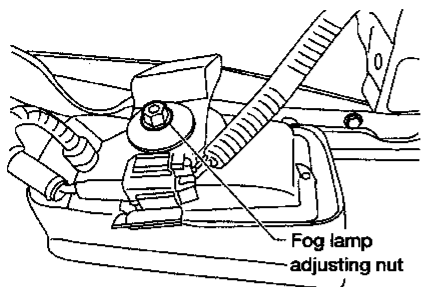

AEL160C

Aiming Adjustment

Before performing aiming adjustment, make sure of the following.

- Keep all tires inflated to correct pressure.
- Place vehicle on level ground.
- Check that vehicle is unloaded (except for full levels of coolant, engine oil and fuel, and spare tire, jack, and tools). Have the driver or equivalent weight placed in driver's seat.

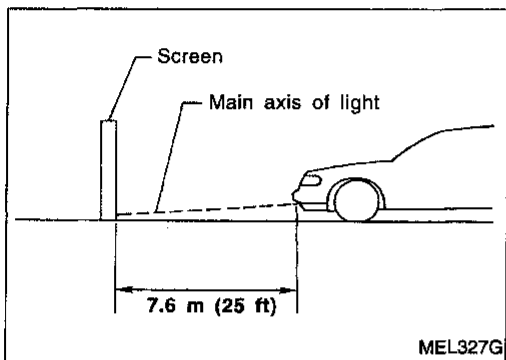

MEL327G

- Set the distance between the screen and the center of the fog lamp lens as shown at left.
- Turn front fog lamps ON.

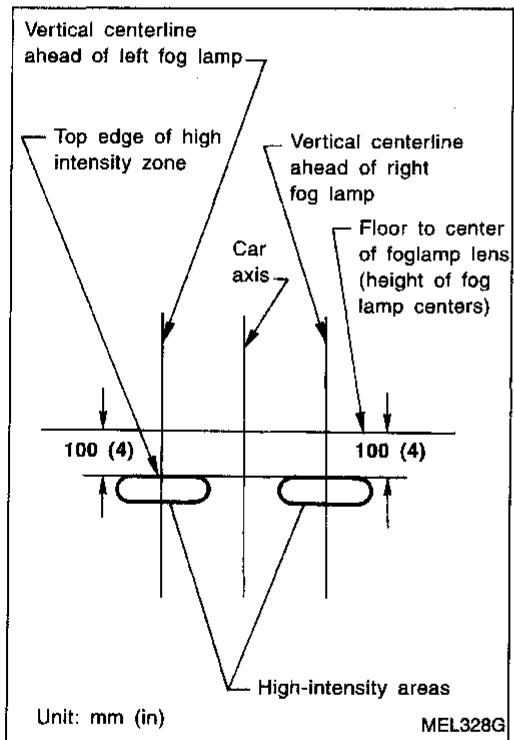

- Adjust front fog lamps so that the top edge of the high intensity zone is 100 mm (4 in) below the height of the fog lamp centers as shown at left.
- When performing adjustment, if necessary, cover the headlamps and opposite fog lamp.

Unit: mm (in)

MEL328G

FRONT FOG LAMP

Removal and Installation

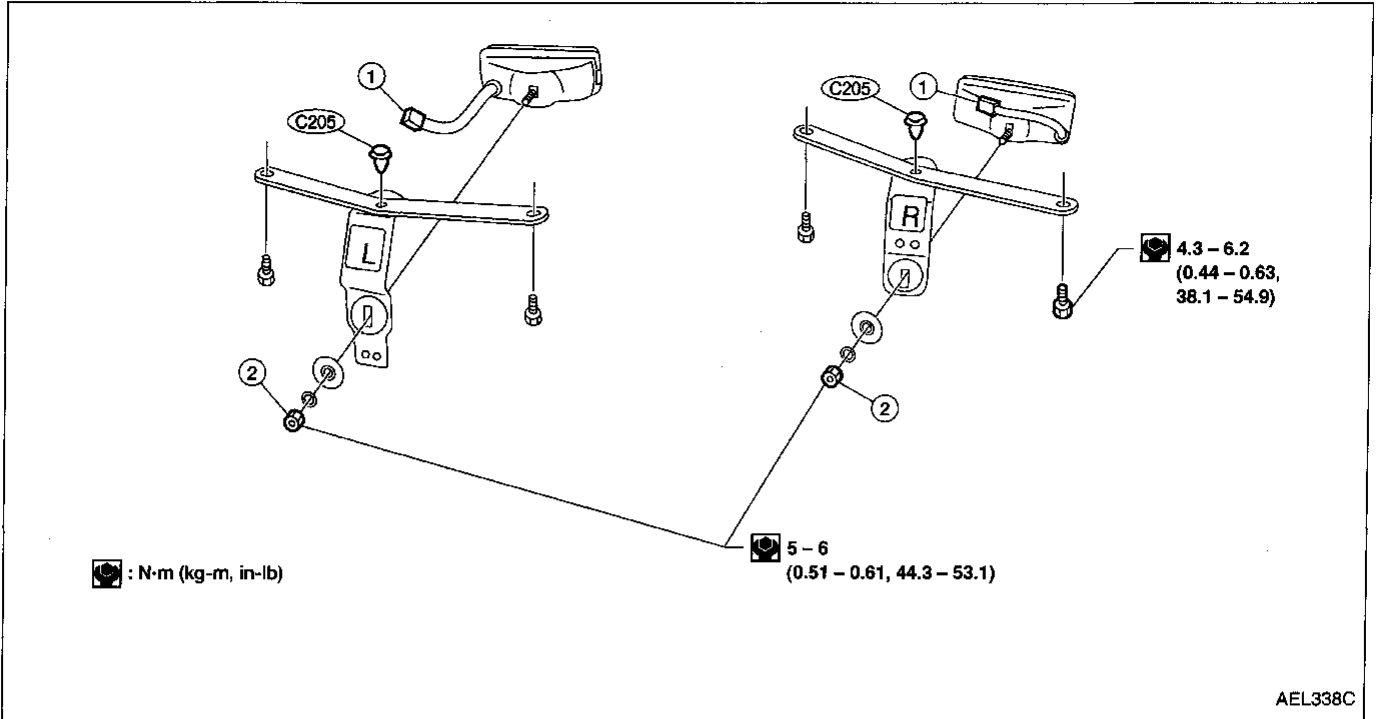

1. Disconnect fog lamp harness connector and separate fog lamp connector from fog lamp bracket.
2. Remove mounting nut and remove lens and housing assembly from fog lamp bracket.
3. Install in reverse order of removal. Ensure top of lens faces up.
4. Tighten mounting nut.
: 5 - 6 N·m (0.51 - 0.61 kg·m, 44.3 - 53.1 in·lb)

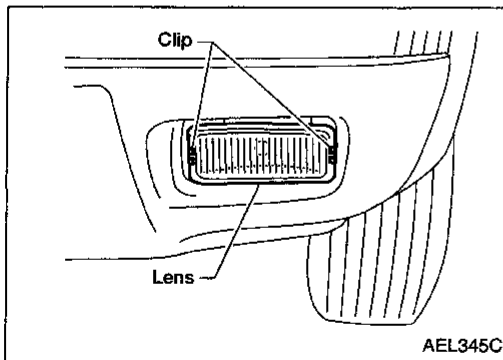

Bulb and Lens Replacement

1. Remove the two metal clips on sides of fog lamp.
2. Pull out and support fog lamp lens.
3. Disconnect fog lamp bulb connector.
4. Lift retaining spring.
5. Remove fog lamp bulb.
 - Fog lamp bulb cannot be separated from wire and is serviced as an assembly.
6. For lens replacement, disconnect ground connector from bulb retainer and remove lens.
7. Install in reverse order of removal. Ensure top of lens faces up.
DO NOT TOUCH BULB.

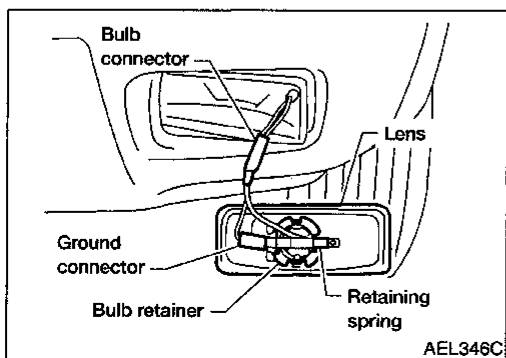

TURN SIGNAL AND HAZARD WARNING LAMPS

System Description

TURN SIGNAL OPERATION

With the hazard switch in the OFF position and the ignition switch in the ON or START position, power is supplied:

- through 7.5A fuse [No. 2], located in the fuse block (J/B)]
- to hazard switch terminal 2
- through terminal 1 of the hazard switch
- to combination flasher unit terminal B
- through terminal L of the combination flasher unit
- to turn signal switch terminal 1.

Ground is supplied to combination flasher unit terminal E through body grounds M14 and M68.

LH turn

When the turn signal switch is moved to the LH position, power is supplied from turn signal switch terminal 3 to:

- front combination lamp LH terminal 1
- combination meter terminal 24
- rear combination lamp LH terminal 2.

Ground is supplied to the front combination lamp LH terminal 2 through body grounds E12 and E54.

Ground is supplied to the rear combination lamp LH terminal 1 through body grounds M14 and M68.

Ground is supplied to combination meter terminal 33 through body grounds M14 and M68.

With power and ground supplied, the combination flasher unit controls the flashing of the LH combination lamps.

RH turn

When the turn signal switch is moved to the RH position, power is supplied from turn signal switch terminal 2 to:

- front combination lamp RH terminal 1
- combination meter terminal 40
- rear combination lamp RH terminal 2.

Ground is supplied to the front combination lamp RH terminal 2 through body grounds E12 and E54.

Ground is supplied to the rear combination lamp RH terminal 1 through body grounds M14 and M68.

Ground is supplied to combination meter terminal 33 through body grounds M14 and M68.

With power and ground supplied, the combination flasher unit controls the flashing of the RH combination lamps.

HAZARD LAMP OPERATION

Power is supplied at all times to hazard switch terminal 3 through:

- 10A fuse [No. 17], located in the fuse block (J/B)].

With the hazard switch in the ON position, power is supplied:

- through terminal 1 of the hazard switch
- to combination flasher unit terminal B
- through terminal L of the combination flasher unit
- to hazard switch terminal 4.

Ground is supplied to combination flasher unit terminal E through body grounds M14 and M68.

Power is supplied through terminal 5 of the hazard switch to:

- front combination lamp LH terminal 1
- combination meter terminal 24
- rear combination lamp LH terminal 2.

Power is supplied through terminal 6 of the hazard switch to:

- front combination lamp RH terminal 1
- combination meter terminal 40
- rear combination lamp RH terminal 2.

Ground is supplied to terminal 2 of each front combination lamp through body grounds E12 and E54.

Ground is supplied to terminal 1 of each rear combination lamp through body grounds M14 and M68.

Ground is supplied to combination meter terminal 33 through body grounds M14 and M68.

With power and ground supplied, the combination flasher unit controls the flashing of the hazard warning lamps.

TURN SIGNAL AND HAZARD WARNING LAMPS

System Description (Cont'd)

WITH MULTI-REMOTE CONTROL SYSTEM

Power is supplied at all times:

- through 10A fuse [No. 17], located in the fuse block (J/B)
- to multi-remote control relay terminals ②, ⑤ and ⑦.

Ground is supplied to multi-remote control relay terminal ①, when the multi-remote control system is triggered through the smart entrance control unit.

Refer to "MULTI-REMOTE CONTROL SYSTEM" (EL-172).

When multi-remote control relay is energized.

Power is supplied through terminal ③ of the multi-remote control relay:

- to front combination lamp LH terminal ①
- to combination meter terminal ②④
- to rear combination lamp LH terminal ②.

Power is supplied through terminal ⑥ of the multi-remote control relay:

- to front combination lamp RH terminal ①
- to combination meter terminal ④⑩
- to rear combination lamp RH terminal ②.

Ground is supplied to terminal ② of each front combination lamp through body grounds E12 and E54.

Ground is supplied to terminal ① of each rear combination lamp through body grounds M14 and M68.

Ground is supplied to combination meter terminal ③③ through body grounds M14 and M68.

With power and ground supplied, the smart entrance control unit controls the flashing of the hazard warning lamps.

GI

MA

EM

LC

EC

FE

CL

MT

AT

TF

PD

FA

RA

BR

ST

RS

BT

HA

EL

IDX

TURN SIGNAL AND HAZARD WARNING LAMPS

Wiring Diagram — TURN —

EL-TURN-01

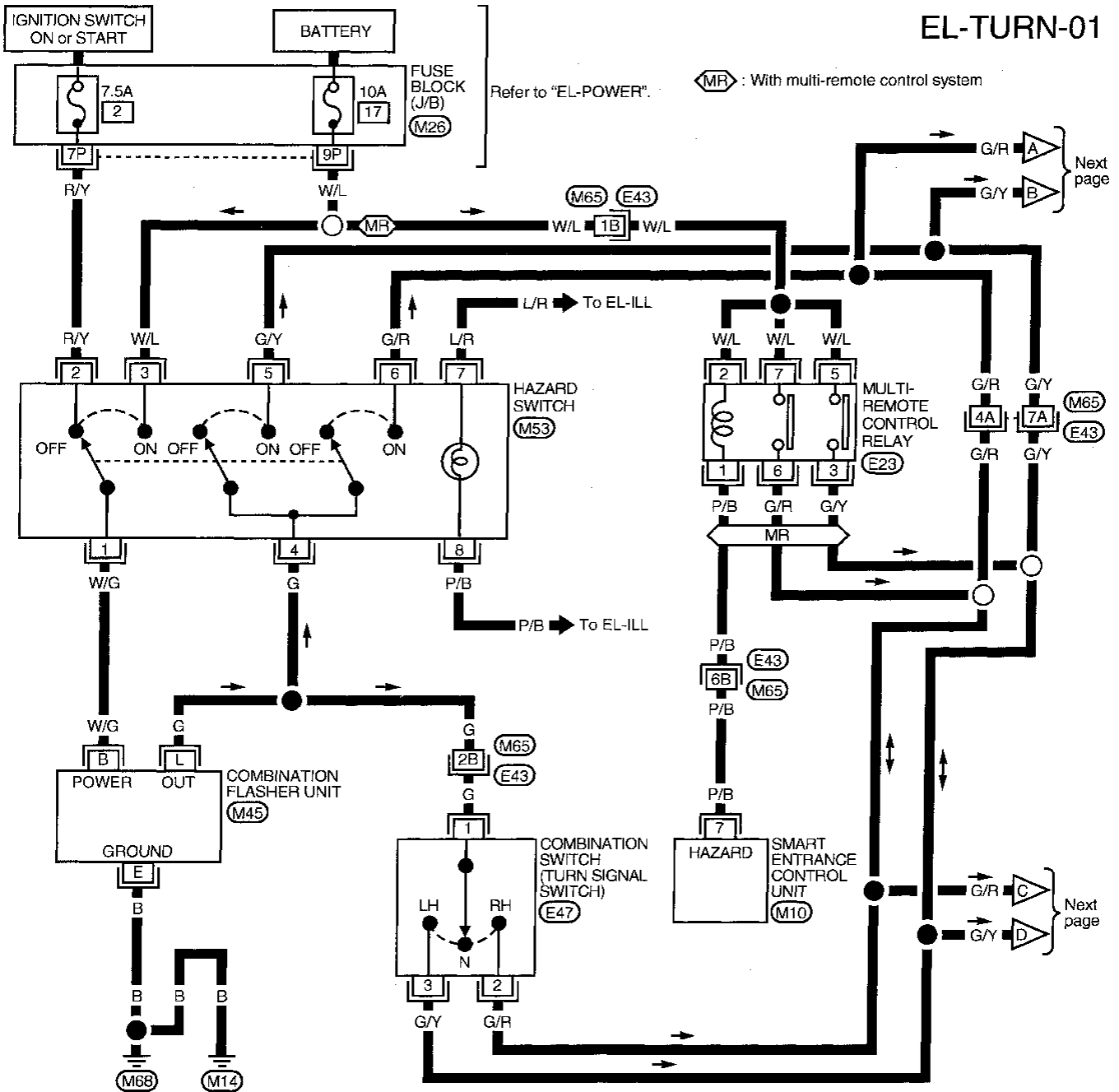

24	25	26	27	28	29	30	31	32	33	34	35	36	6	7	8	9	10	(M10)
11	12	13	14	15	16	17	18	19	20	21	22	23	1	2	3	4	5	W

1P	2P	3P	4P	5P	6P	7P	(M26)		
8P	9P	10P	11P	12P	13P	14P	15P	16P	W

B	E	(M45)
L	B	

4	5	6	(M53)		
8	7	2	1	3	W

1	2	(E23)
5	7	BR
3	6	

	O	(E47)	
3	1	2	W

Refer to last page (Foldout page).
(M65), (E43)

TURN SIGNAL AND HAZARD WARNING LAMPS

Wiring Diagram — TURN — (Cont'd)

EL-TURN-02

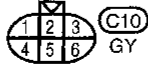
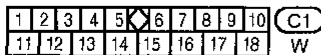
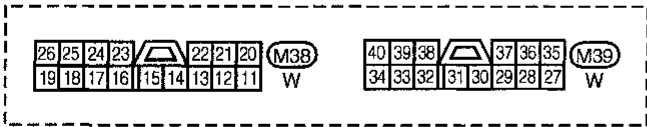
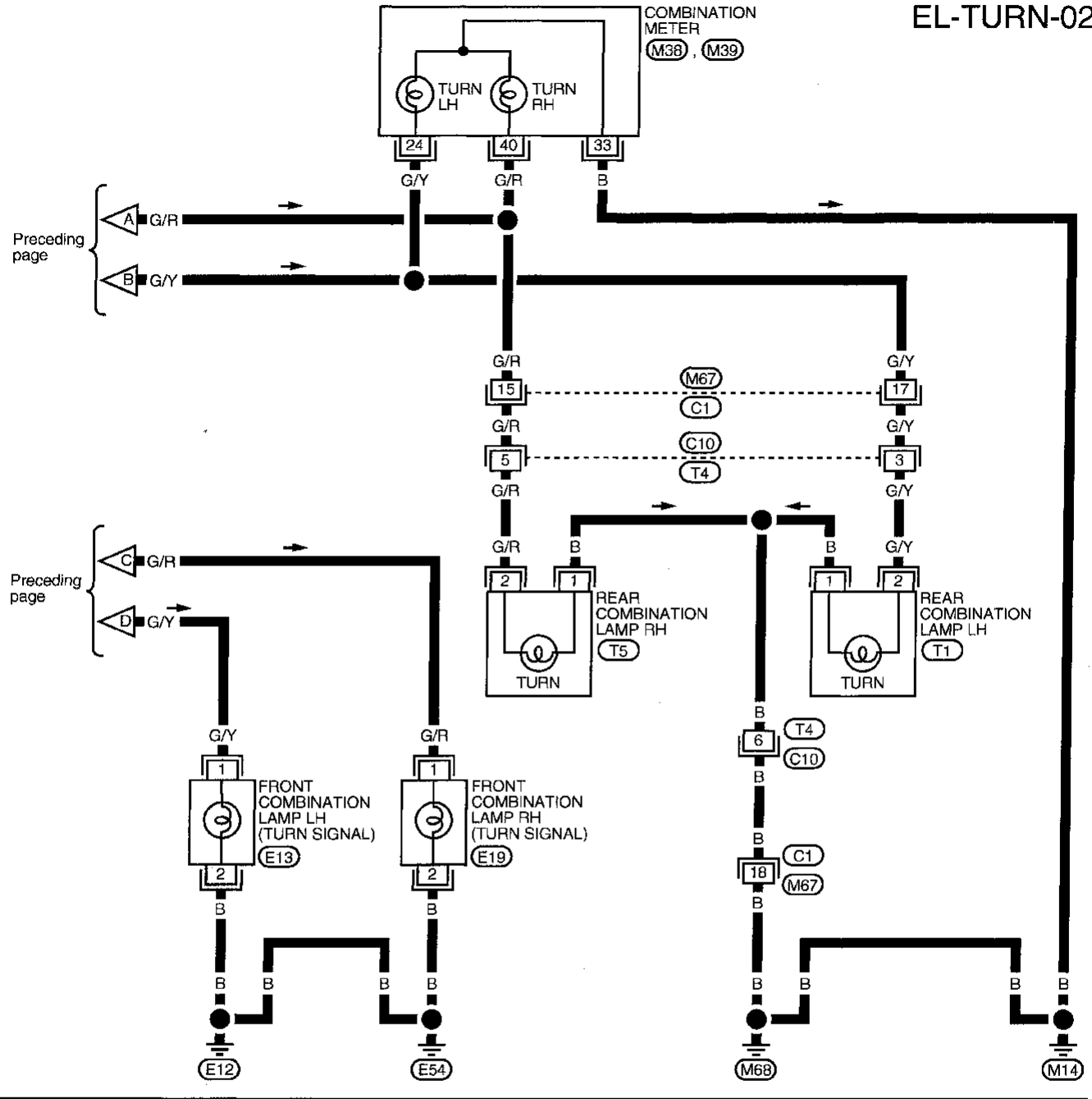

GI
 MA
 EM
 LC
 EC
 FE
 CL
 MT
 AT
 TF
 PD
 FA
 RA
 BR
 ST
 RS
 BT
 HA
EL
 IDX

TURN SIGNAL AND HAZARD WARNING LAMPS

Trouble Diagnoses

Symptom	Possible cause	Repair order
Turn signal and hazard warning lamps do not operate.	<ol style="list-style-type: none"> 1. Hazard switch 2. Combination flasher unit 3. Open in combination flasher unit circuit 	<ol style="list-style-type: none"> 1. Check hazard switch. 2. Refer to combination flasher unit check. 3. Check wiring to combination flasher unit for open circuit.
Turn signal lamps do not operate but hazard warning lamps operate.	<ol style="list-style-type: none"> 1. 7.5A fuse 2. Hazard switch 3. Turn signal switch 4. Open in turn signal switch circuit 	<ol style="list-style-type: none"> 1. Check 7.5A fuse [No. ②], located in fuse block (J/B). Turn ignition switch ON and verify battery positive voltage is present at terminal ② of hazard switch. 2. Check hazard switch. 3. Check turn signal switch. 4. Check G wire between combination flasher unit and turn signal switch for open circuit.
Hazard warning lamps do not operate but turn signal lamps operate.	<ol style="list-style-type: none"> 1. 10A fuse 2. Hazard switch 3. Open in hazard switch circuit 	<ol style="list-style-type: none"> 1. Check 10A fuse [No. ①], located in fuse block (J/B). Verify battery positive voltage is present at terminal ③ of hazard switch. 2. Check hazard switch. 3. Check G wire between combination flasher unit and hazard switch for open circuit.
Front turn signal lamp LH or RH does not operate.	<ol style="list-style-type: none"> 1. Bulb 2. Grounds (E12) and (E54) 	<ol style="list-style-type: none"> 1. Check bulb. 2. Check grounds (E12) and (E54).
Rear turn signal lamp LH or RH does not operate.	<ol style="list-style-type: none"> 1. Bulb 2. Grounds (M14) and (M68) 	<ol style="list-style-type: none"> 1. Check bulb. 2. Check grounds (M14) and (M68).
LH and RH turn indicators do not operate.	<ol style="list-style-type: none"> 1. Ground 	<ol style="list-style-type: none"> 1. Check grounds (M14) and (M68).
LH or RH turn indicator does not operate.	<ol style="list-style-type: none"> 1. Bulb 	<ol style="list-style-type: none"> 1. Check bulb in combination meter.

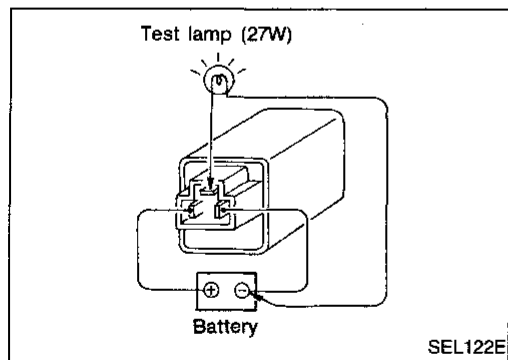

Electrical Components Inspection

COMBINATION FLASHER UNIT CHECK

- Before checking, ensure that bulbs meet specifications.
- Connect a battery and test lamp to the combination flasher unit, as shown. Combination flasher unit is properly functioning if it blinks when power is supplied to the circuit.

ILLUMINATION

System Description

Power is supplied at all times:

- through 10A fuse (No. 39, located in the fuse and fusible link box)
- to lighting switch terminal ①.

With the ignition switch in the ON or START position, power is supplied:

- through 10A fuse [No. 11], located in the fuse block (J/B)]
- to combination meter terminal 29.

The lighting switch must be in parking lamp (1ST) or headlamp ON (2ND) position for illumination.

The illumination control switch controls the amount of current to the illumination system. As the amount of current increases, the illumination becomes brighter.

The following chart shows the power and ground connector terminals for the components included in the illumination system.

Component	Connector No.	Power terminal	Ground terminal
Illumination control switch	M28	①	⑤
ASCD main switch	M29	⑤	⑥
Main power window and door lock/unlock switch	D7	③	④
Combination meter	M39	29, 39	36
Radio	M51	⑧	⑦
Hazard switch	M53	⑦	⑧
Fan switch	M56	②	①

The ground for all of the components is controlled through terminal ④ of the illumination control switch and body grounds M14 and M68.

GI

MA

EM

LC

EC

FE

CL

MT

AT

TF

PD

FA

RA

BR

ST

RS

BT

HA

EL

IDX

ILLUMINATION

Wiring Diagram — ILL —

EL-ILL-01

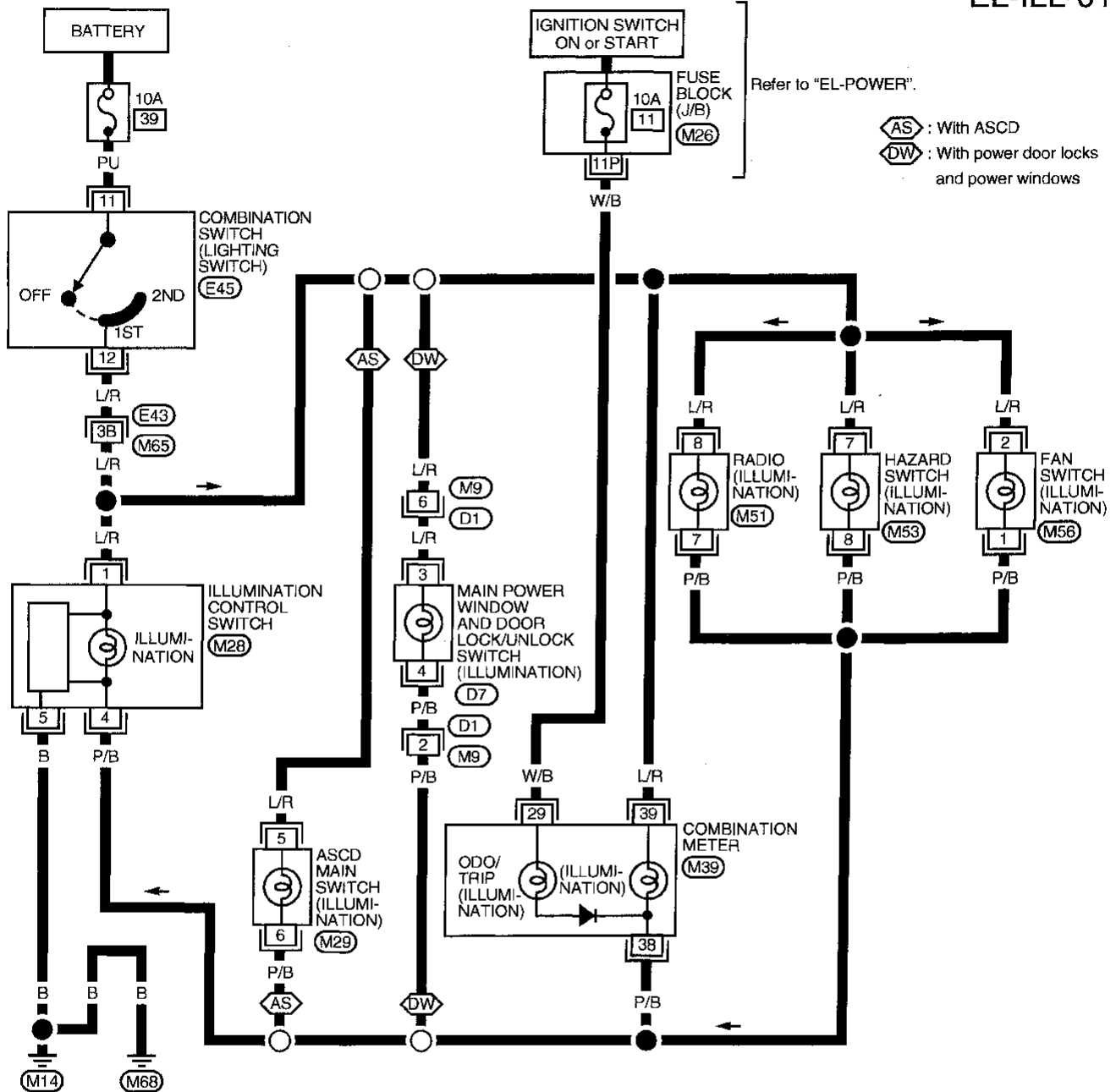

Refer to last page (Foldout page).

(M65), (E43)

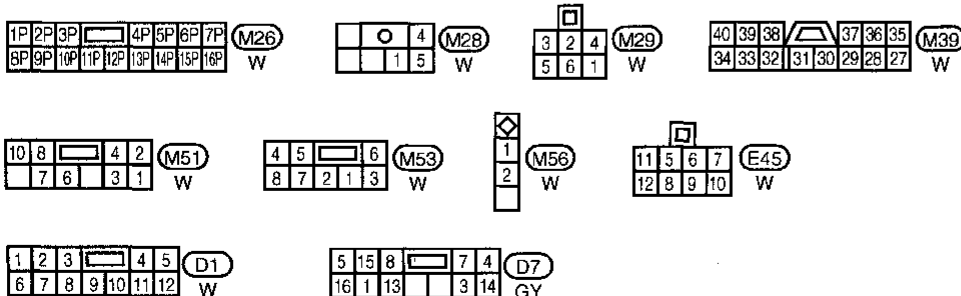

INTERIOR ROOM LAMP

Component Parts and Harness Connector Location

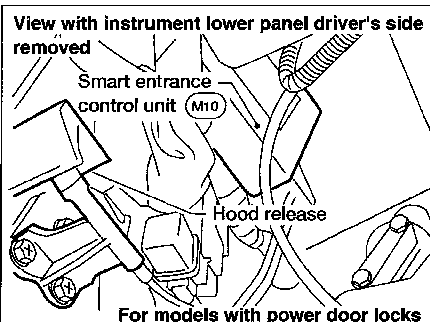
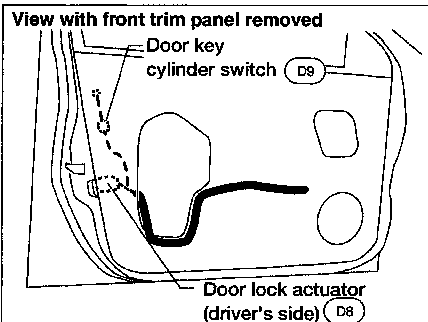
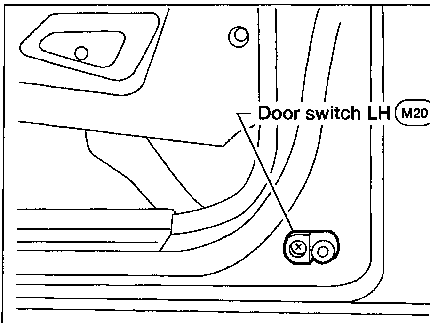
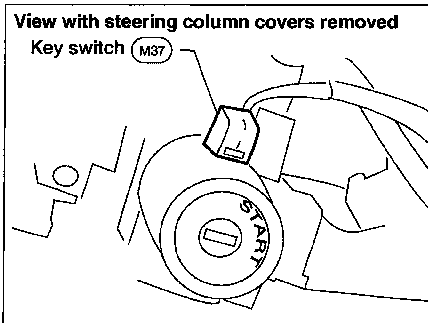
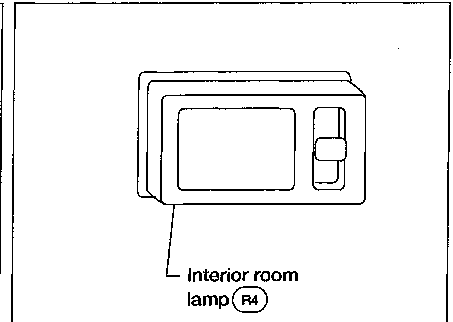
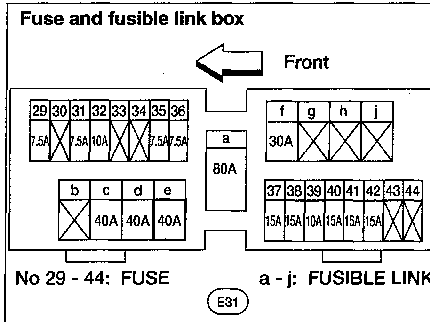
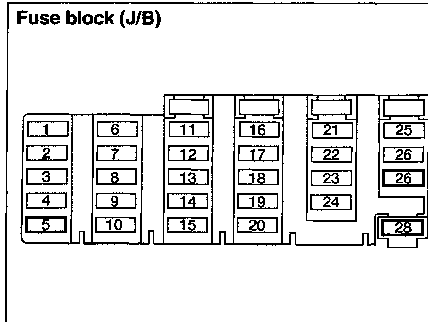

GI
MA
EM
LC
EC
FE
CL
MT
AT
TF
PD
FA
RA
BR
ST
RS
BT
HA
EL
IDX

System Description

MODELS WITH POWER DOOR LOCKS

Power supply and ground

Power is supplied at all times:

- through 30A fusible link (Letter **f**, located in the fuse and fusible link box)
- to circuit breaker terminal **①**
- through circuit breaker terminal **②**
- to smart entrance control unit terminal **①**.

Power is supplied at all times:

- through 7.5A fuse [No. **28**, located in the fuse block (J/B)]
- to key switch terminal **①**.

Power is supplied at all times:

- through 7.5A fuse [No. **26**, located in the fuse block (J/B)]
- to room lamp terminal **+**.

When the key is inserted into ignition key cylinder, power is supplied:

- from key switch terminal **②**
- to smart entrance control unit terminal **24**.

With the ignition switch in the ON or START position, power is supplied:

- through 7.5A fuse [No. **5**, located in the fuse block (J/B)]
- to smart entrance control unit terminal **11**.

Ground is supplied:

- through body grounds **M14** and **M68**
- to smart entrance control unit terminal **10**.

When the LH door is opened, ground is supplied:

- from door switch LH terminal **②**
- to smart entrance control unit terminal **15**.

When the RH door is opened, ground is supplied:

- from door switch RH terminal **①**
- to smart entrance control unit terminal **35**.

When the LH door is unlocked, the smart entrance control unit receives a ground signal:

- through body grounds **M14** and **M68**
- to door unlock sensor terminal **4**
- from door unlock sensor terminal **②**
- to smart entrance control unit terminal **12**.

When a signal, or combination of signals is received by the smart entrance control unit, ground is supplied:

- through smart entrance control unit terminal **9**
- to room lamp terminal **SW**.

With power and ground supplied, the interior room lamp illuminates.

Switch operation

When the room lamp switch is ON, ground is supplied:

- through body grounds **M14** and **M68**
- to room lamp terminal **-**.

With power and ground supplied, the room lamp turns ON and remains ON until the room lamp switch is turned to OFF or turned to the DOOR position and the doors are closed.

Interior room lamp timer operation

When the room lamp switch is in the DOOR position, the smart entrance control unit keeps the interior room lamp illuminated for about 30 seconds when:

- LH door is unlocked
- key is removed from ignition key cylinder while driver's door is closed
- driver's door is opened and then closed while ignition switch is not in the ON position.

The timer is canceled, and interior room lamp turns off when:

- driver's door is locked with remote controller, or
- ignition switch is turned ON.

The smart entrance control unit will shut off the room light if left on for 30 minutes.

INTERIOR ROOM LAMP

System Description (Cont'd)

ON-OFF control

When the room lamp switch is in the DOOR position, when the driver side door or passenger door is opened the room lamp turns on.

When any door is opened and then closed while the ignition switch is not in the ON position, the room lamp timer operates.

MODELS WITHOUT POWER DOOR LOCKS

Power is supplied at all times:

- through 7.5A fuse [No. 26, located in the fuse block (J/B)]
- to room lamp terminal (+).

With the room lamp switch ON, ground is supplied:

- through body grounds (M14) and (M68)
- to room lamp terminal (-).

When a door is opened with the room lamp switch in DOOR position, ground is supplied:

- through door switch LH or RH terminal (1)
- to room lamp switch terminal (SW).

With power and ground supplied, the room lamp turns ON.

GI

MA

EM

LC

EC

FE

CL

MT

AT

TF

PD

FA

RA

BR

ST

RS

BT

HA

EL

IDX

INTERIOR ROOM LAMP

Wiring Diagram — ROOM/L —

MODELS WITH POWER DOOR LOCKS

EL-ROOM/L-01

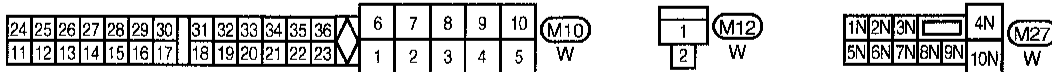
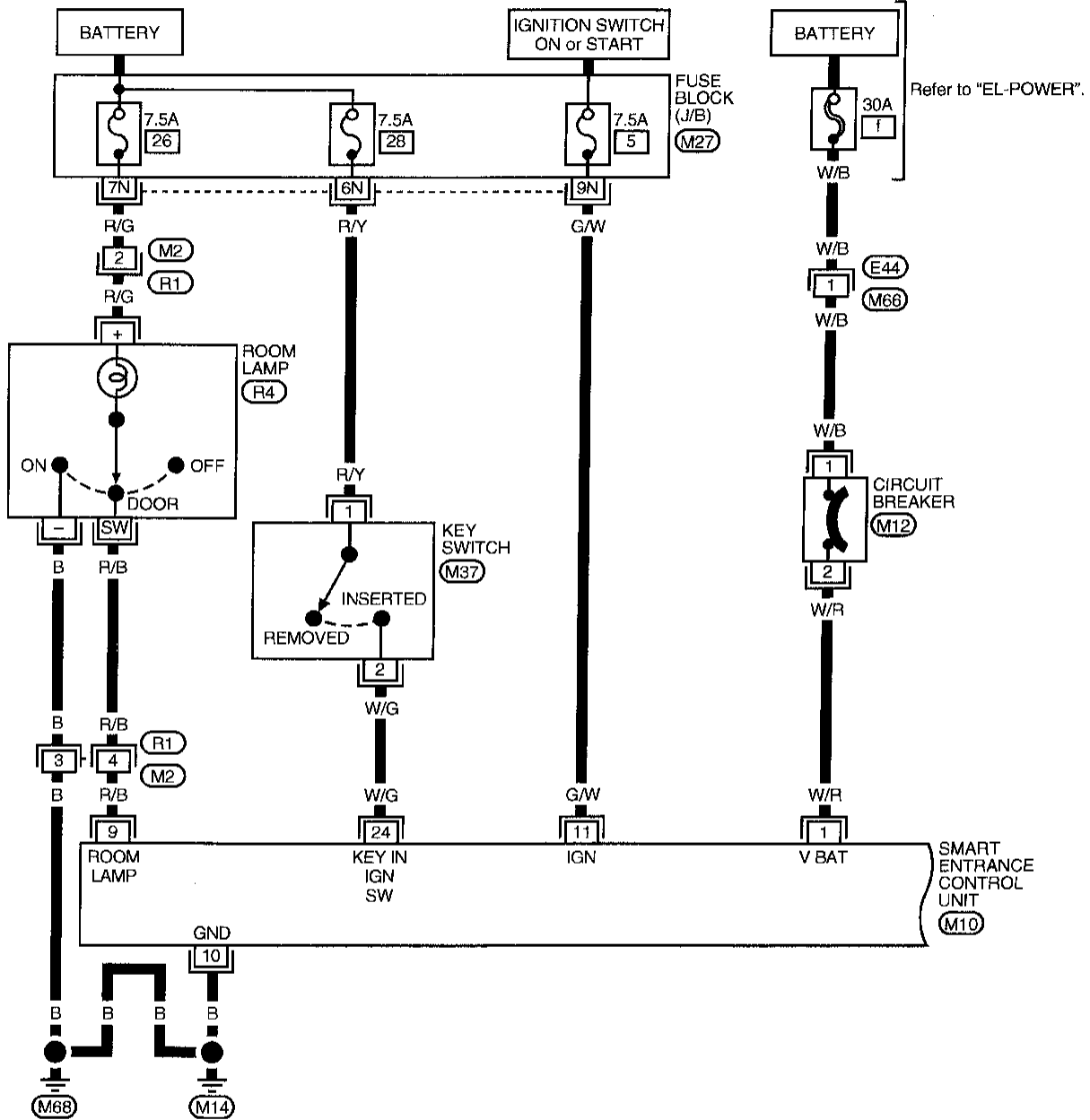

INTERIOR ROOM LAMP

Wiring Diagram — ROOM/L — (Cont'd)

EL-ROOM/L-02

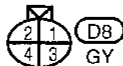
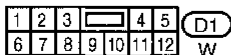
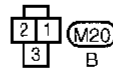
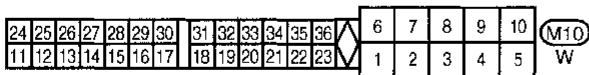
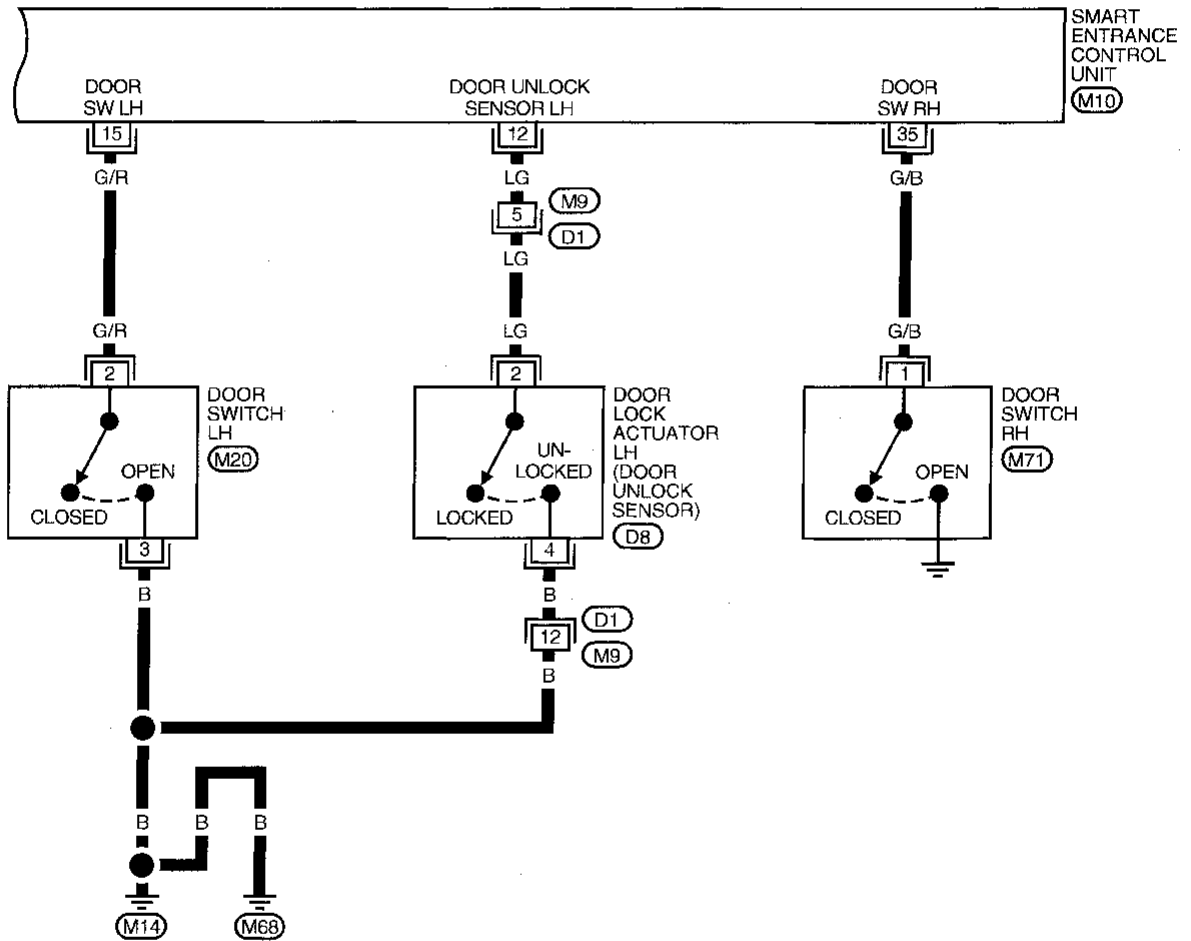

GI
 MA
 EM
 LC
 EC
 FE
 CL
 MT
 AT
 TF
 PD
 FA
 RA
 BR
 ST
 RS
 BT
 HA
 EL
 IDX

INTERIOR ROOM LAMP

Wiring Diagram — ROOM/L — (Cont'd)

MODELS WITHOUT POWER DOOR LOCKS

EL-ROOM/L-03

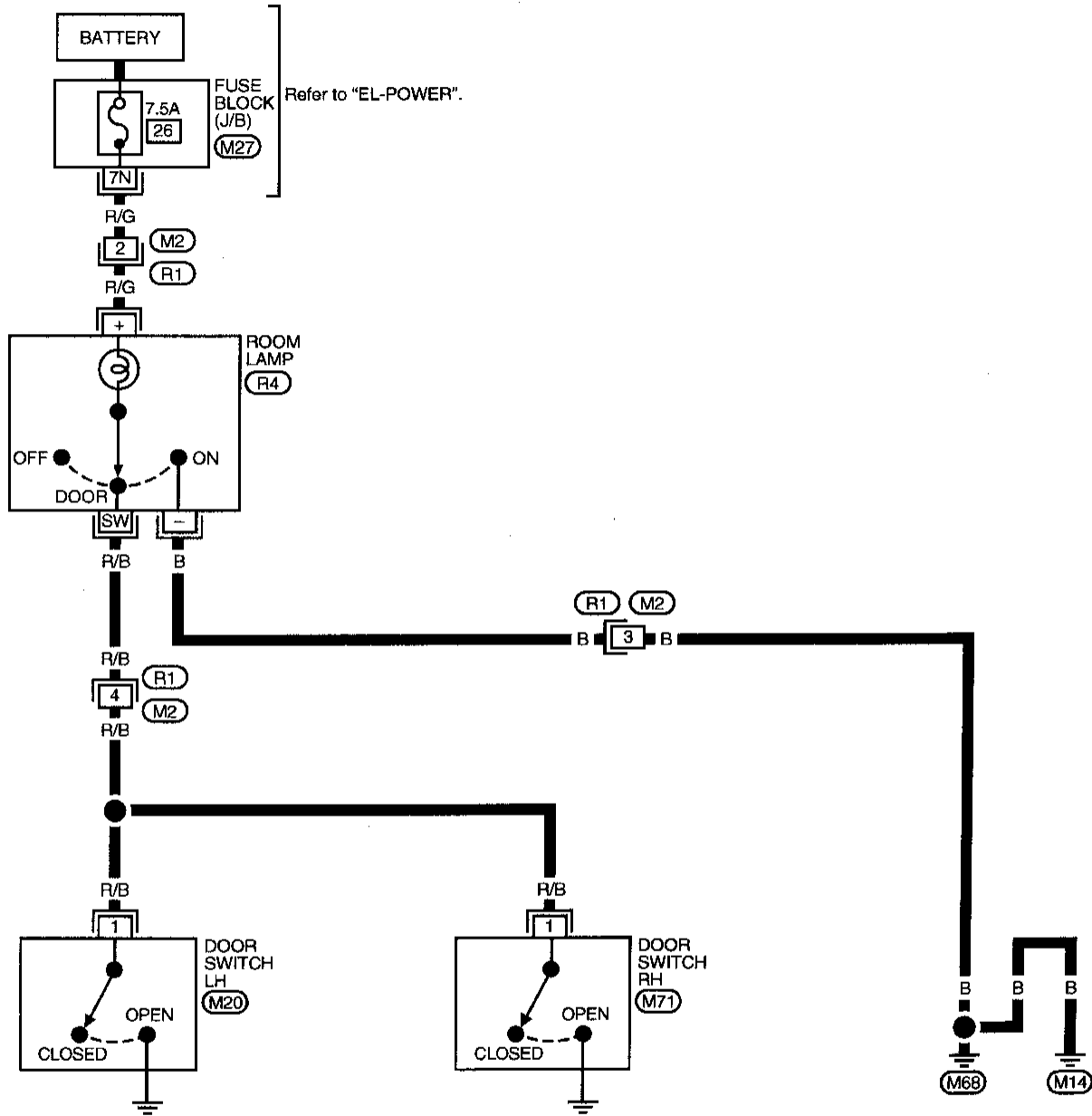

INTERIOR ROOM LAMP

GI
MA
EM
LC
EC
FE
CL
MT
AT
TF
PD
FA
RA
BR
ST
RS
BT
HA
EL
IDX

Trouble Diagnoses (For models with power door locks)

DIAGNOSTIC PROCEDURE

SYMPTOM: Room lamp does not turn on when any door is opened, or timer does not operate properly.

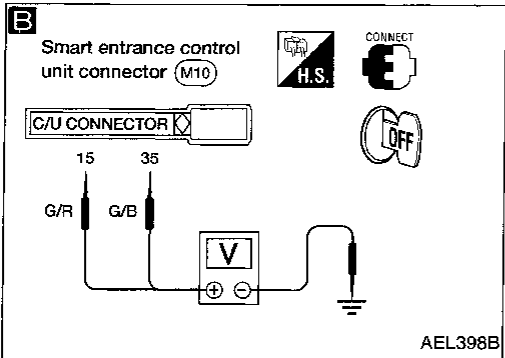
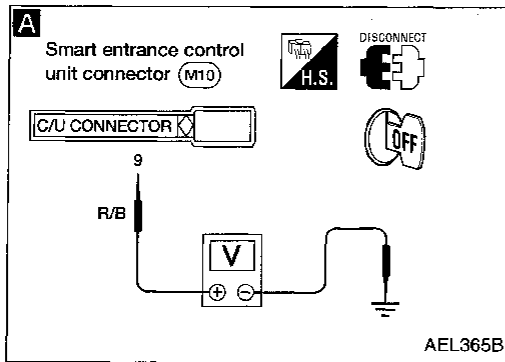

Does room lamp turn on when room lamp switch is in "ON" position?

No

Check the following.

- Bulb
- 7.5A fuse [No. 20, located in the fuse block (J/B)]
- Harness for open or short between fuse and room lamp
- Room lamp ground circuit

Yes

Does key warning chime operate properly?

No

Check "WARNING CHIME" system. (Refer to EL-102.)

Yes

Does power door lock operate using driver side knob lock switch?

No

Check "POWER DOOR LOCK" system. (Refer to EL-157.)

Yes

A

CHECK ROOM LAMP OUTPUT SIGNAL.

1. Turn room lamp switch to "DOOR" position.
2. Disconnect control unit connector.
3. Check voltage between control unit terminal ⑨ and ground.

Battery voltage should exist.

NG

Check harness for open or short between room lamp and control unit.

OK

B

CHECK DOOR SWITCH INPUT SIGNAL.

1. Connect control unit connector.
2. Check voltage between control unit terminal ⑮, ⑳ and ground.

	Terminals		Condition	Voltage [V]
	⊕	⊖		
Door switch LH	⑮	Ground	Open	0
			Closed	12
Door switch RH	⑳	Ground	Open	0
			Closed	12

NG

Check the following.

- Door switch
- Door switch ground circuit (LH) or door switch ground condition (RH)
- Harness for open or short between control unit and door switches

OK

Replace control unit.

SPOT LAMP

Wiring Diagram — INT/L —

EL-INT/L-01

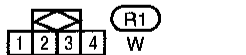
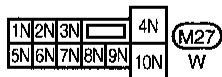
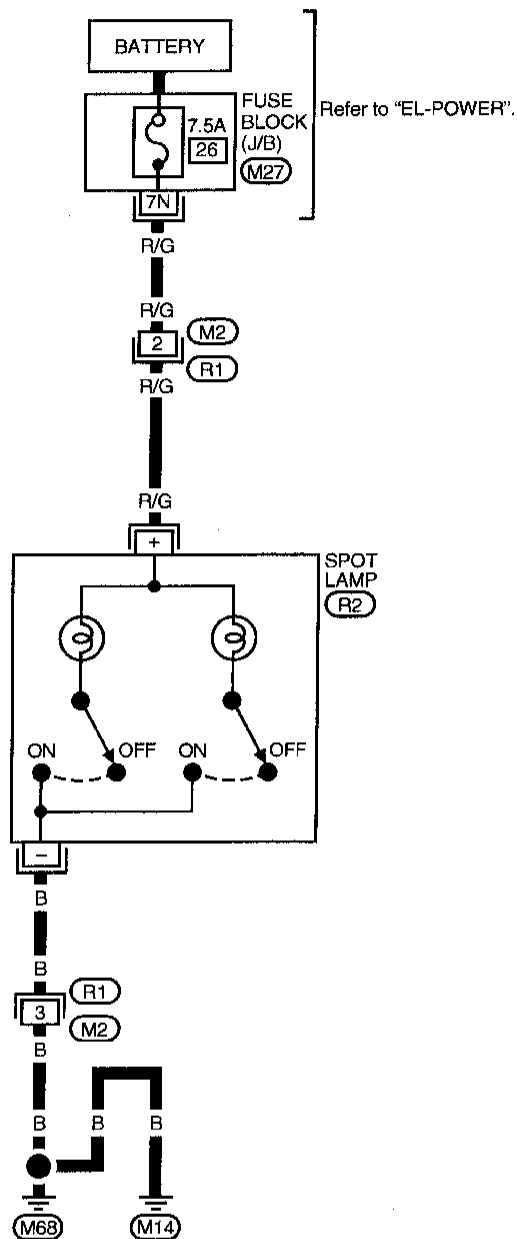

METER AND GAUGES

Component Parts and Harness Connector Location

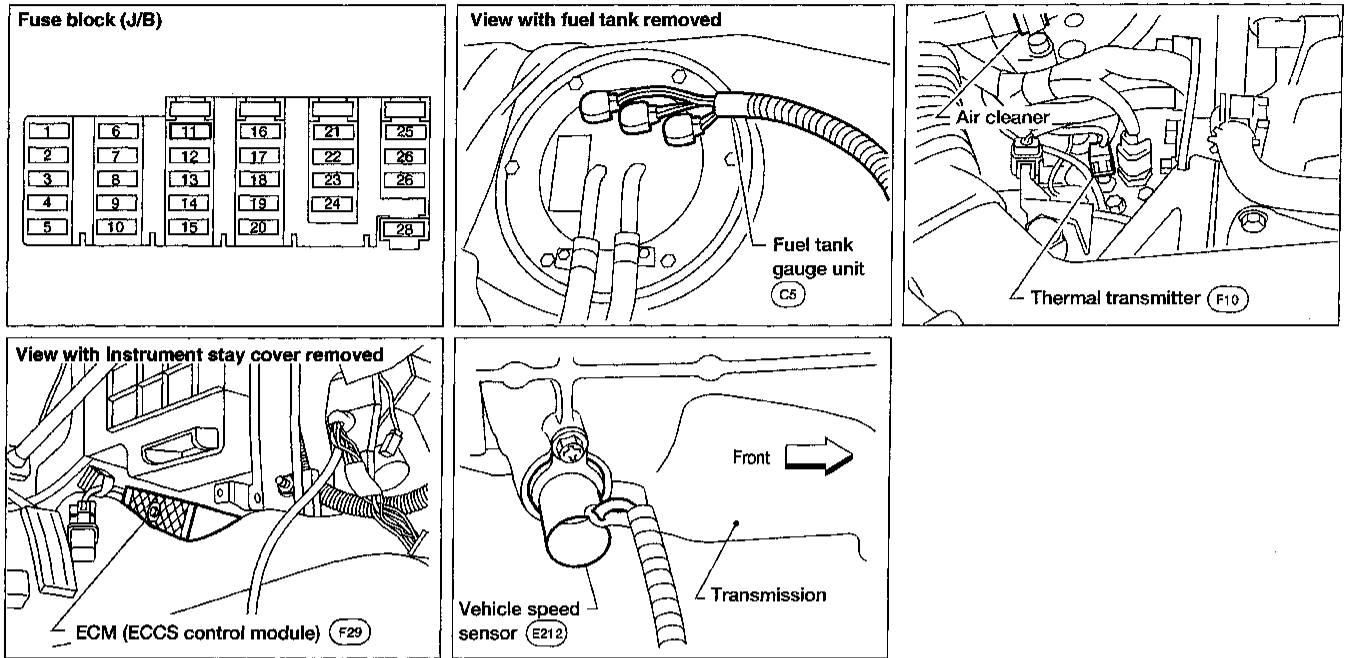

GI
MA
EM
LC
EC
FE
CL
MT
AT
TF
PD
FA
RA
BR
ST
RS
BT
HA
EL
IDX

METER AND GAUGES

System Description

UNIFIED CONTROL METER

- Speedometer, odo/trip meter, tachometer, fuel gauge and water temperature gauge are controlled totally by control unit combined with speedometer.
- Digital meter is adopted for odo/trip meter.*
*The record of the odo meter is kept even if the battery cable is disconnected. The record of the trip meter is erased when the battery cable is disconnected.
- Odo/trip meter segment can be checked in diagnosis mode.
- Meter/gauge can be checked in diagnosis mode.

HOW TO CHANGE THE DISPLAY FOR ODO/TRIP METER

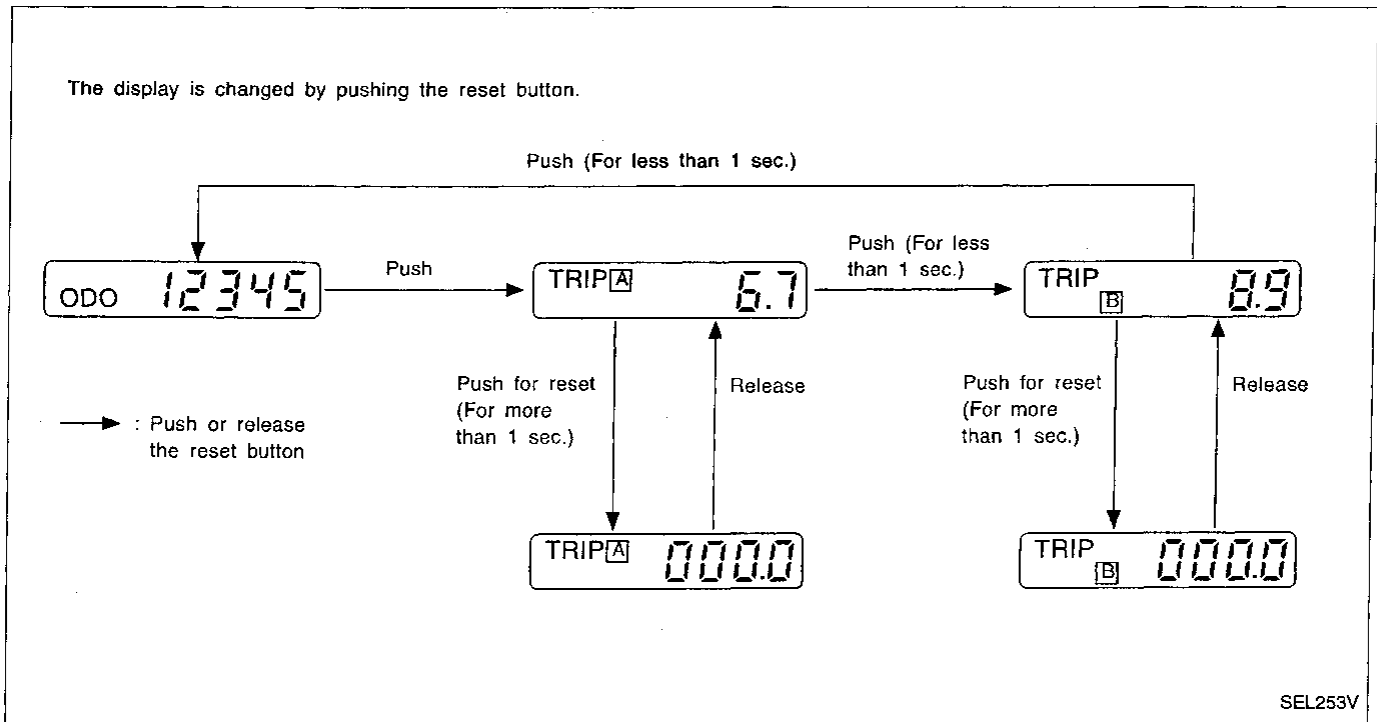

Note: Turn ignition switch to the ON position to operate odo/trip meter.

POWER SUPPLY AND GROUND CIRCUIT

With the ignition switch in the ON or START position, power is supplied:

- through 10A fuse [No. ⑪], located in the fuse block (J/B)]
- to combination meter terminal ⑳.

Ground is supplied:

- to combination meter terminal ㉑
- through body grounds ㉒ and ㉓.

FUEL GAUGE

The fuel gauge indicates the approximate fuel level in the fuel tank.

The fuel gauge is regulated by a variable ground signal supplied:

- to combination meter terminal ㉔ for the fuel gauge
- from terminal ㉕ of the fuel tank gauge unit
- through terminal ㉖ of the fuel tank gauge unit and
- through body grounds ㉒ and ㉓.

WATER TEMPERATURE GAUGE

The water temperature gauge indicates the engine coolant temperature. The reading on the gauge is based on the resistance of the thermal transmitter.

As the temperature of the coolant increases, the resistance of the thermal transmitter decreases. A variable ground is supplied to terminal ㉗ of the combination meter for the water temperature gauge. The needle on the gauge moves from "C" to "H".

METER AND GAUGES

System Description (Cont'd)

TACHOMETER

The tachometer indicates engine speed in revolutions per minute (rpm).

The tachometer is regulated by a signal:

- from terminal ③ of the ECM
- to combination meter terminal ⑨ for the tachometer.

SPEEDOMETER

The vehicle speed sensor provides a voltage signal to the combination meter for the speedometer.

The voltage is supplied:

- to combination meter terminals ⑧ and ⑩ for the speedometer
- from terminals ② and ① of the vehicle speed sensor.

The speedometer converts the voltage into the vehicle speed displayed.

GI

MA

EM

LC

EC

FE

CL

MT

AT

TF

PD

FA

RA

BR

ST

RS

BT

HA

EL

IDX

METER AND GAUGES

Combination Meter

WITH TACHOMETER

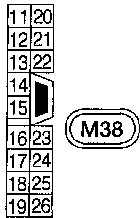
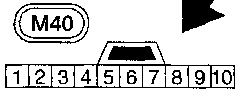
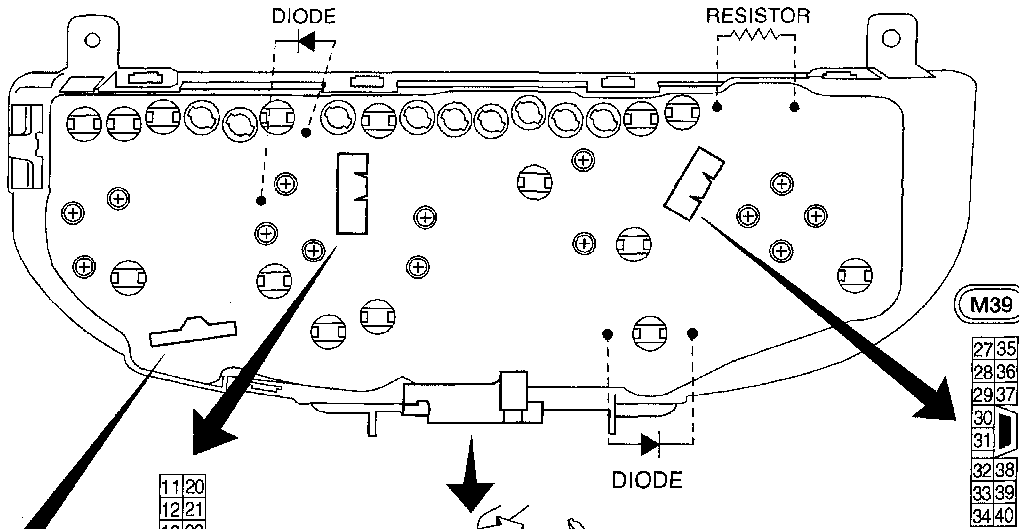
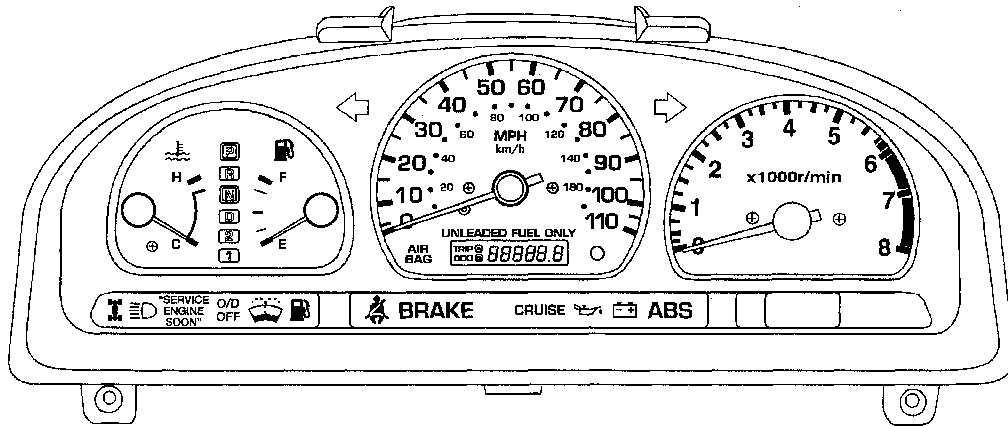

- (N) : For Canada
- (LF) : With low fuel indication
- (AS) : With ASCD
- (FD) : With 4-wheel drive
- (2A) : With 2-wheel ABS
- (4A) : With 4-wheel ABS

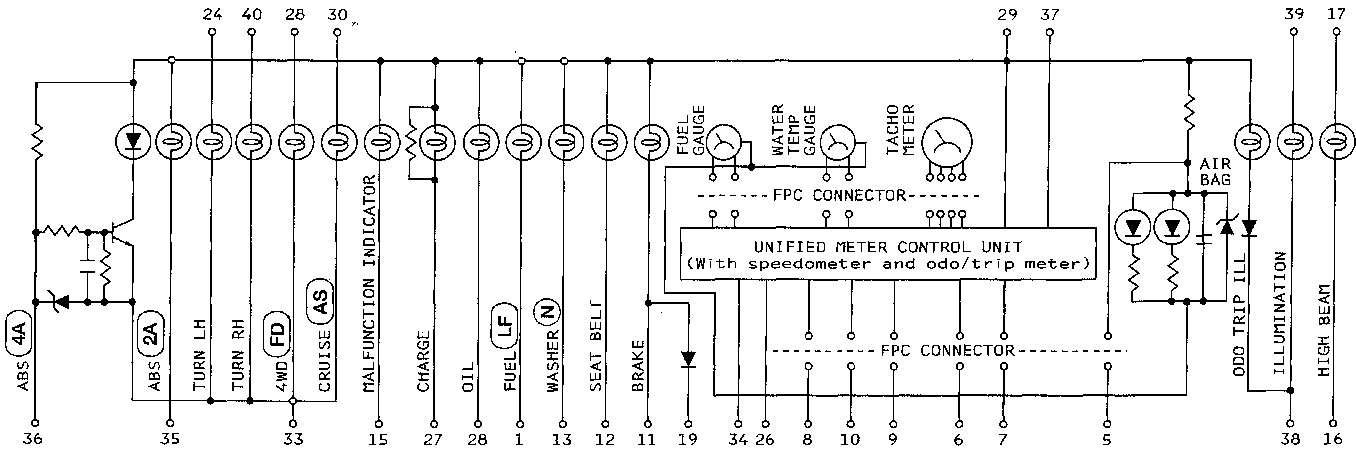

AEL124C

METER AND GAUGES

Combination Meter (Cont'd)

WITHOUT TACHOMETER

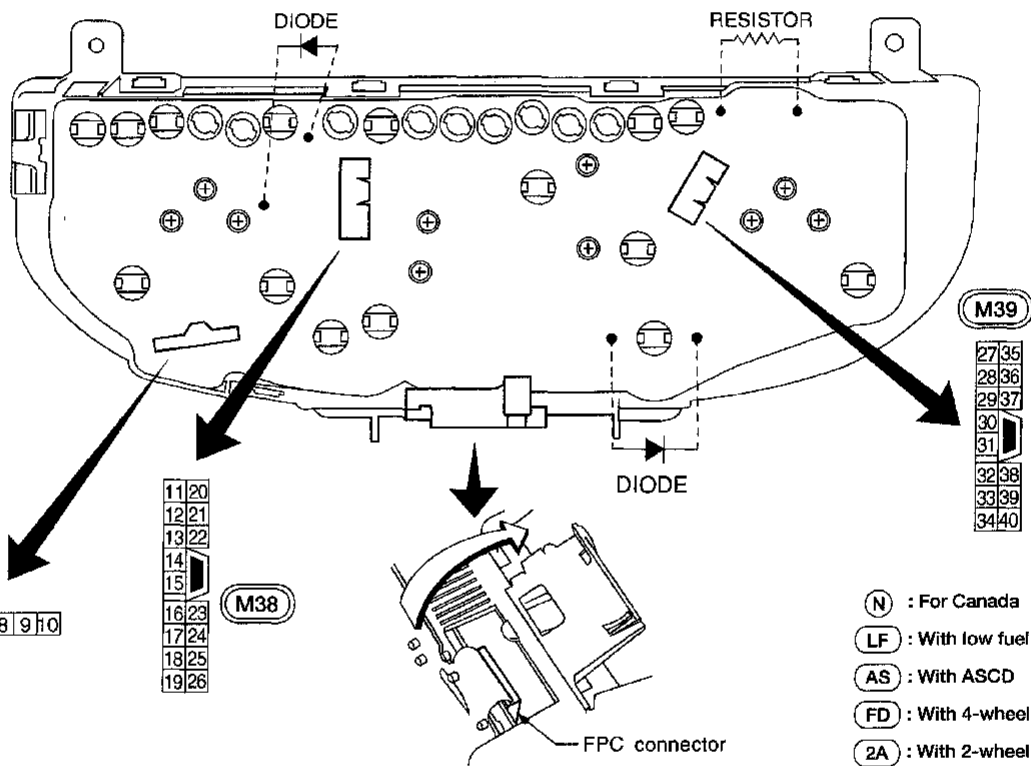
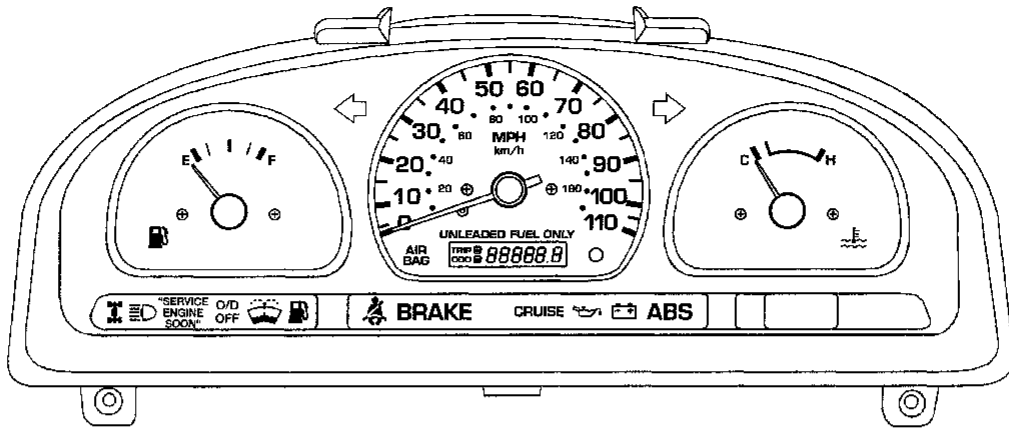

- (N) : For Canada
- (LF) : With low fuel indication
- (AS) : With ASCD
- (FD) : With 4-wheel drive
- (2A) : With 2-wheel ABS
- (4A) : With 4-wheel ABS

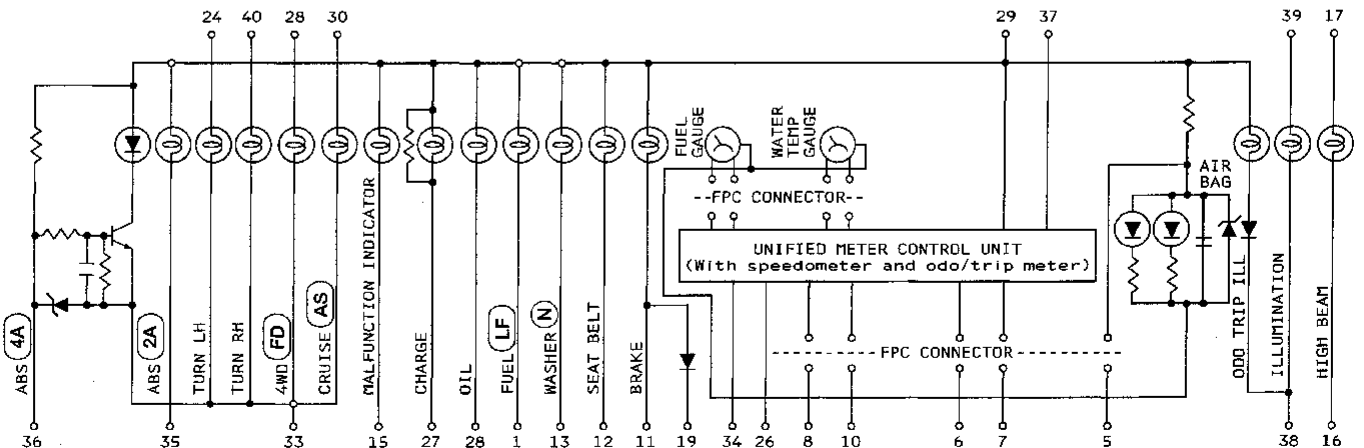

METER AND GAUGES

Wiring Diagram — METER —

EL-METER-01

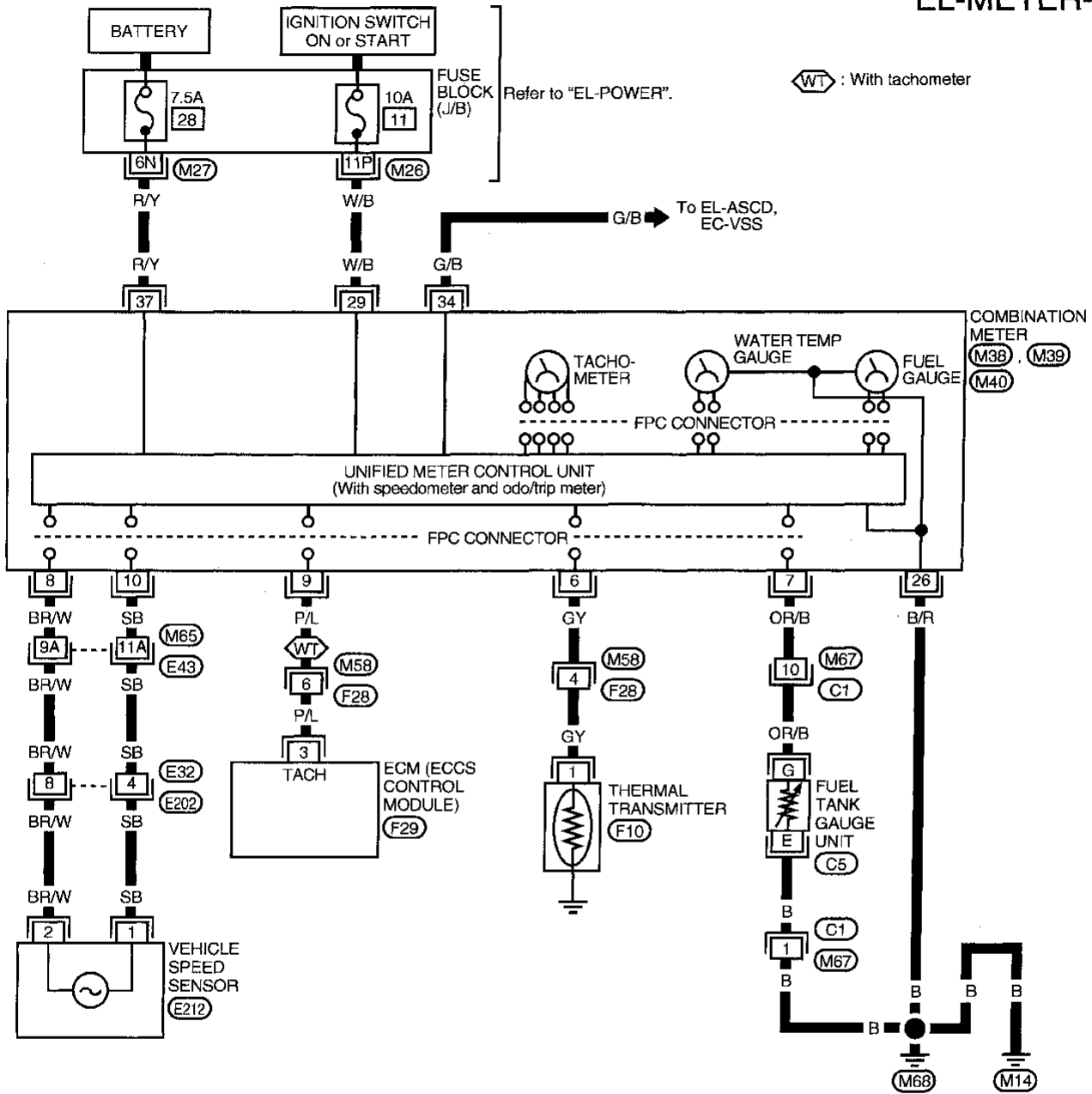

WT : With tachometer

Refer to "EL-POWER".

To EL-ASCD, EC-VSS

Refer to last page (Foldout page).

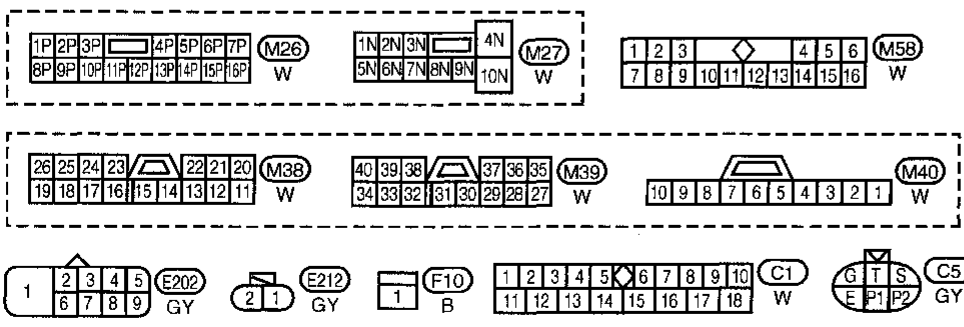

M65, E43, F29

Meter/gauge Operation and Odo/Trip Meter Segment Check in Diagnosis Mode

DIAGNOSIS FUNCTION

- Odo/trip meter segment can be checked in diagnosis mode.
- Meters/gauges can be checked in diagnosis mode.

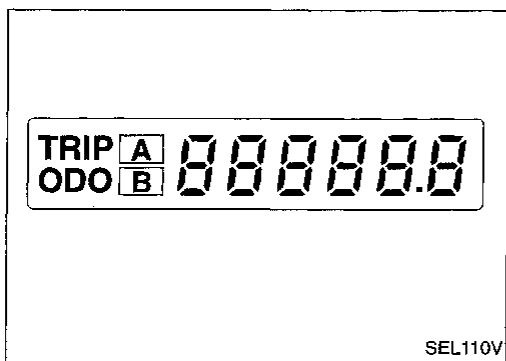

HOW TO ALTERNATE DIAGNOSIS MODE

1. Turn ignition switch to ON and change odo/trip meter to "TRIP A" or "TRIP B".
2. Turn ignition switch to OFF.
3. Turn ignition switch to ON when pushing odo/trip meter switch.
4. Confirm that trip meter indicates "000.0".
5. Push odo/trip meter switch more than three times within 5 seconds.
6. All odo/trip meter segments should be turned on.

NOTE: If some segments are not turned on, speedometer (unified meter control unit) with odo/trip meter should be replaced.

At this point, the unified control meter is turned to diagnosis mode.

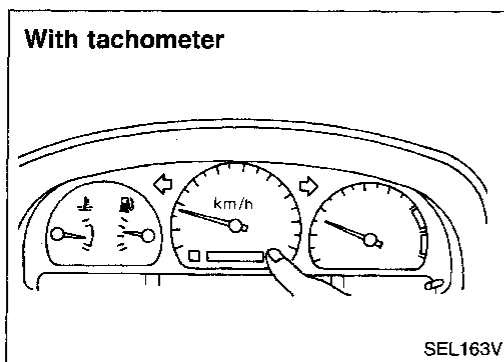

7. Push odo/trip meter switch. Indication of each meter/gauge should be as shown left during pushing odo/trip meter switch if it is not malfunctioning.

NOTE: It takes about 1 minute for indication of fuel gauge to become stable.

GI
MA
EM
LC
EC
FE
CL
MT
AT
TF
PD
FA
RA
BR
ST
RS
BT
HA
EL
IDX

METER AND GAUGES

Meter/gauge Operation and Odo/Trip Meter Segment Check in Diagnosis Mode (Cont'd)

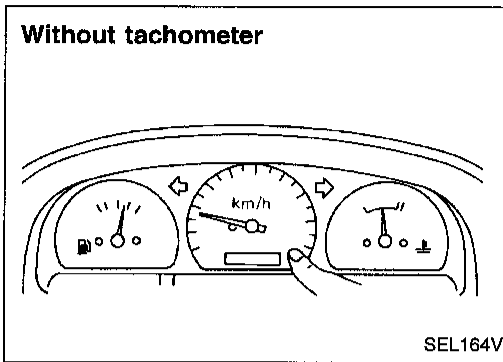

Flexible Print Circuit (FPC)

Tachometer, fuel gauge and water temperature gauge are connected with unified meter control unit (speedometer) by Flexible Print Circuit (FPC) connector. When replacing or removing and installing unified control unit (speedometer), disconnect and connect FPC connector according to the following steps.

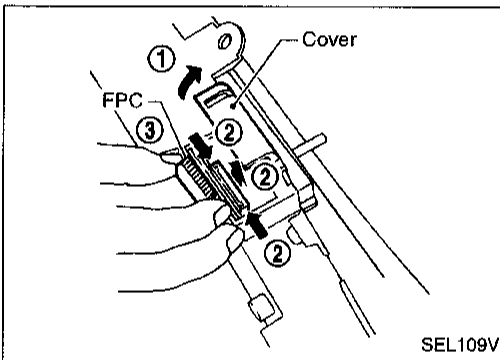

DISCONNECT

1. Open connector cover.
2. Release connector lock by holding both ends of it and pulling it up.
3. Disconnect FPC by pulling it up.

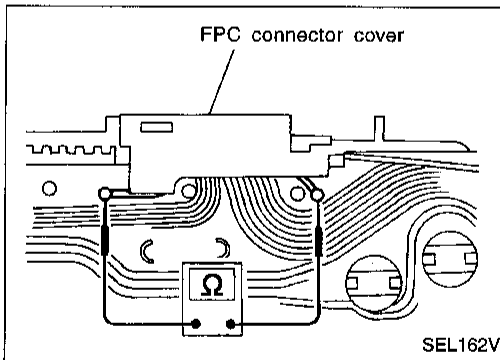

CONNECT

1. Insert FPC into connector and lock connector pushing FPC downward.
2. Check secure connection of FPC.
3. Check continuity of check land terminals for secure connection of FPC.

Resistance: 0Ω

4. Close connector cover.

Trouble Diagnoses

PRELIMINARY CHECK

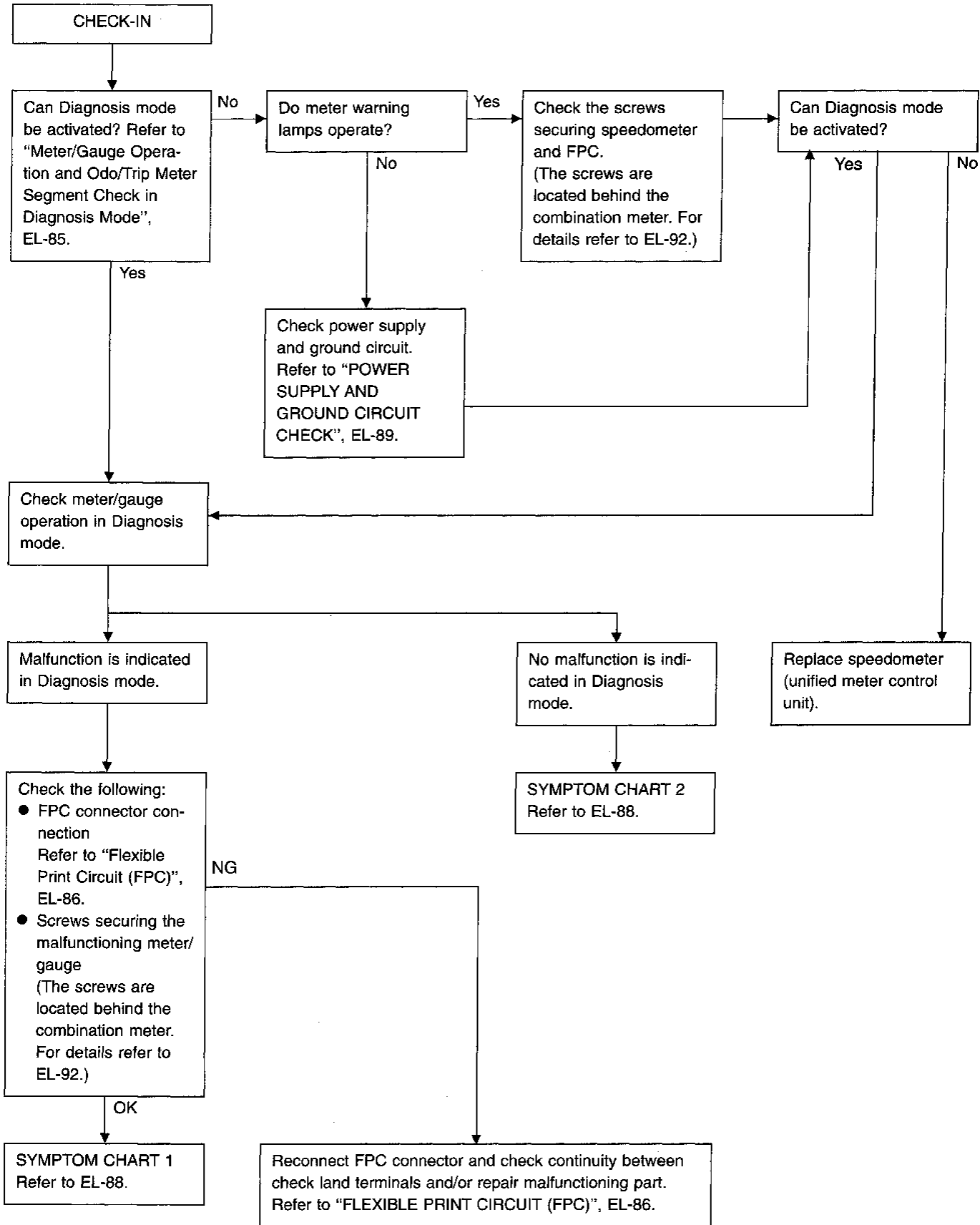

GI
MA
EM
LC
EC
FE
CL
MT
AT
TF
PD
FA
RA
BR
ST
RS
BT
HA
EL
IDX

METER AND GAUGES

Trouble Diagnoses (Cont'd)

SYMPTOM CHART 1 (Malfunction is indicated in diagnosis mode)

Symptom	Possible causes	Repair order
Speedometer and/or odometer/trip meter indicate(s) malfunction in Diagnosis mode.	<ul style="list-style-type: none"> ● Speedometer (Unified meter control unit) 	<ul style="list-style-type: none"> ● Replace speedometer (unified meter control unit).
Multiple meter/gauge indicate malfunction in Diagnosis mode.		
One of tachometer/fuel gauge/water temp. gauge indicates malfunction in Diagnosis mode.	<ul style="list-style-type: none"> ● Meter/Gauge ● Speedometer (Unified meter control unit) 	<ol style="list-style-type: none"> 1. Check resistance of meter/gauge indicating malfunction. If the resistance is NG, replace the meter/gauge. Refer to "METER/GAUGE RESISTANCE CHECK", EL-92. 2. If the resistance is OK, replace speedometer (unified meter control unit).

SYMPTOM CHART 2 (No malfunction is indicated in diagnosis mode)

Symptom	Possible causes	Repair order
Speedometer and odometer/trip meter are malfunctioning.	<ol style="list-style-type: none"> 1. Sensor <ul style="list-style-type: none"> - Speedometer, Odo/Trip meter 2. FPC connector 3. Speedometer (Unified meter control unit) 	<ol style="list-style-type: none"> 1. Check vehicle speed sensor. INSPECTION/VEHICLE SPEED SENSOR (Refer to EL-90.) 2. Check FPC connector. Refer to "FLEXIBLE PRINT CIRCUIT (FPC)", EL-86. 3. Replace speedometer (unified meter control unit).
Multiple meter/gauge are malfunctioning. (except speedometer, odometer/trip meter)	<ol style="list-style-type: none"> 1. FPC connector 2. Speedometer (Unified meter control unit) 	<ol style="list-style-type: none"> 1. Check FPC connector. Refer to "FLEXIBLE PRINT CIRCUIT (FPC)", EL-86. 2. Replace speedometer (unified meter control unit).
One of tachometer/fuel gauge/water temp. gauge is malfunctioning.	<ol style="list-style-type: none"> 1. Sensor/Engine revolution signal <ul style="list-style-type: none"> - Tachometer - Fuel gauge - Water temp. gauge 2. FPC connector 3. Speedometer (Unified meter control unit) 	<ol style="list-style-type: none"> 1. Check the sensor for malfunctioning meter/gauge. INSPECTION/ENGINE REVOLUTION SIGNAL (Refer to EL-90.) INSPECTION/FUEL TANK GAUGE (Refer to EL-91.) INSPECTION/THERMAL TRANSMITTER (Refer to EL-91.) 2. Check FPC connector. Refer to "FLEXIBLE PRINT CIRCUIT (FPC)", EL-86. 3. Replace speedometer (unified meter control unit).

Before starting trouble diagnoses, perform PRELIMINARY CHECK, EL-87.

METER AND GAUGES

Trouble Diagnoses (Cont'd)

POWER SUPPLY AND GROUND CIRCUIT CHECK

GI
MA
EM
LC
EC
FE
CL
MT
AT
TF
PD
FA
RA
BR
ST
RS
BT
HA
EL
IDX

Power supply circuit check

Terminals		Ignition switch position		
⊕	⊖	OFF	ACC	ON
Ⓣ7	Ground	Battery voltage	Battery voltage	Battery voltage
Ⓣ9	Ground	0V	0V	Battery voltage

If NG, check the following.

- 7.5A fuse [No. 28, located in fuse block (J/B)]
- 10A fuse [No. 11, located in fuse block (J/B)]
- Harness for open or short between fuse and combination meter

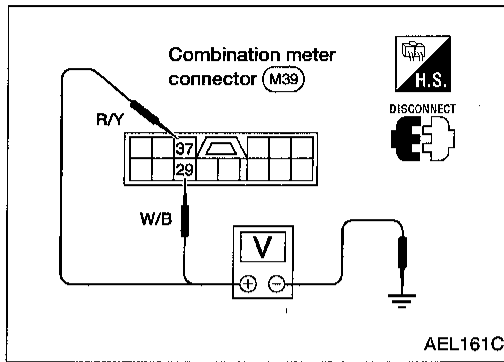

AEL161C

Ground circuit check

Terminals	Continuity
Ⓣ6 - Ground	Yes

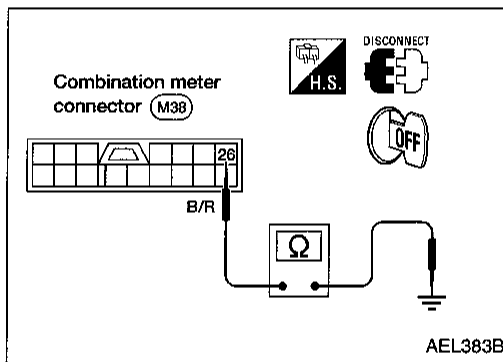

AEL383B

METER AND GAUGES

Trouble Diagnoses (Cont'd)

INSPECTION/VEHICLE SPEED SENSOR

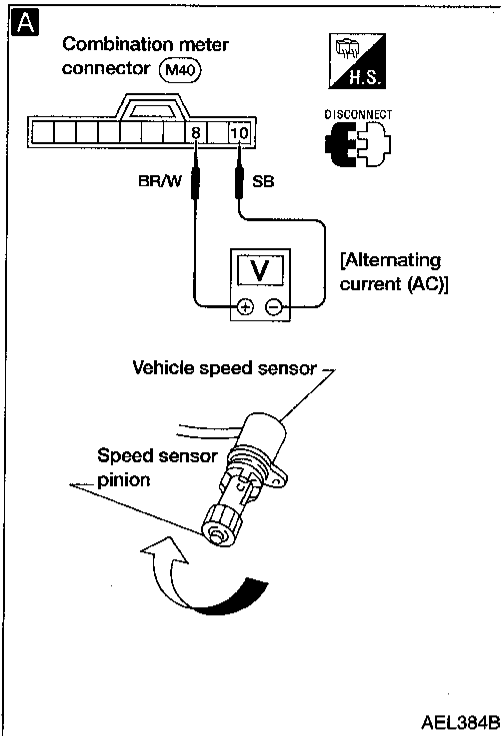

A

CHECK VEHICLE SPEED SENSOR OUTPUT.

1. Remove vehicle speed sensor from transmission and leave vehicle speed sensor connector connected.
2. Check voltage between combination meter terminals (8) and (10) while quickly turning speed sensor pinion.

Voltage: Approx. 0.5V

OK → Vehicle speed sensor is OK.

NG

B

CHECK VEHICLE SPEED SENSOR.

Check resistance between vehicle speed sensor terminals (1) and (2).

Resistance: Approx. 250Ω

NG → Replace vehicle speed sensor.

OK

Check harness or connector between speedometer and vehicle speed sensor.

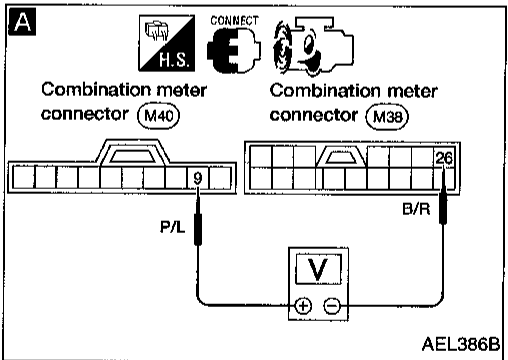
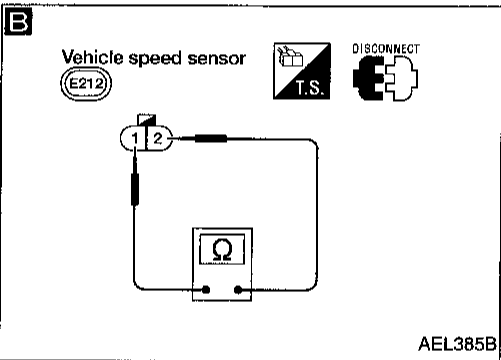

INSPECTION/ENGINE REVOLUTION SIGNAL (Models with tachometer)

A

CHECK ECM OUTPUT.

1. Start engine.
2. Check voltage between combination meter terminals (9) and (26) at idle and 2,000 rpm.

Higher rpm = Higher voltage
Lower rpm - Lower voltage
Voltage should change with rpm.

OK → Engine revolution signal is OK.

NG

Check the following:

- Harness for open or short between ECM and combination meter.

METER AND GAUGES

Trouble Diagnoses (Cont'd)

INSPECTION/FUEL TANK GAUGE

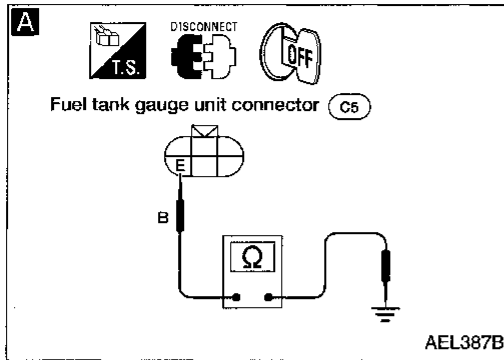

A

CHECK GROUND CIRCUIT FOR FUEL TANK GAUGE UNIT.
Check harness continuity between fuel tank gauge unit terminal **(E)** and ground.
Continuity should exist.

NG → Repair harness or connector.

OK ↓

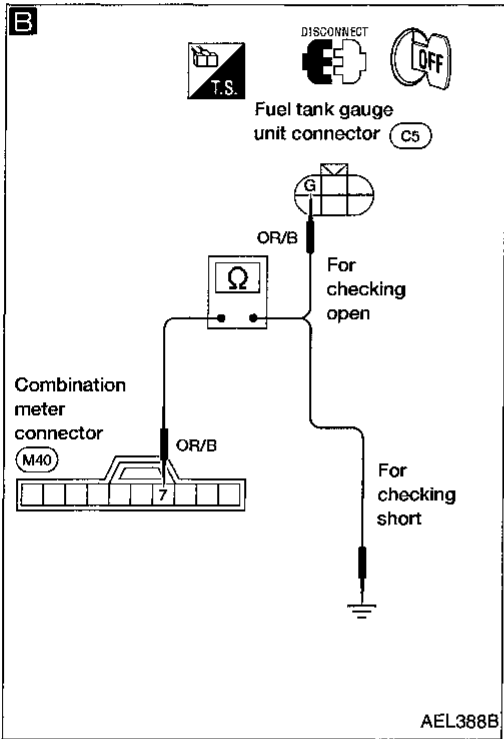

CHECK GAUGE UNITS.
Refer to "FUEL TANK GAUGE UNIT CHECK" (EL-92).

NG → Repair or replace. Refer to FE section.

OK ↓

B

CHECK HARNESS.

1. Disconnect combination meter connector **(M40)** and fuel tank gauge unit connector.
2. Check harness continuity between combination meter terminal **(7)** and fuel tank gauge unit terminal **(G)**.
Continuity should exist.
3. Check continuity between combination meter terminal **(7)** and ground.
Continuity should not exist.

NG → Repair harness or connector.

OK ↓

Fuel tank gauge is OK.

INSPECTION/THERMAL TRANSMITTER

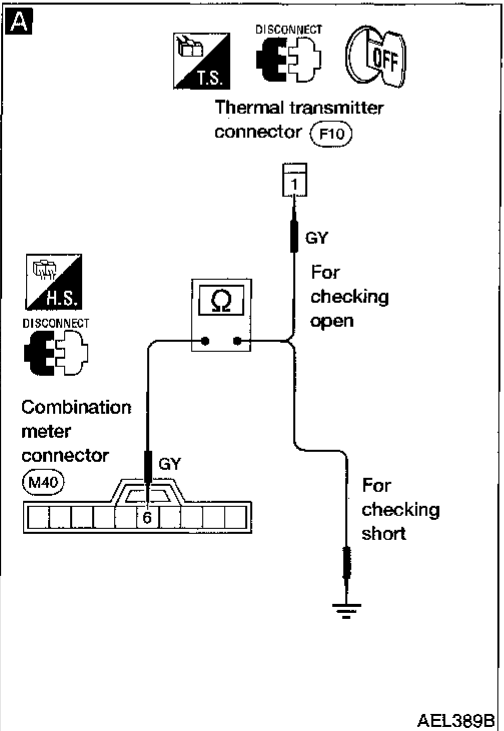

CHECK THERMAL TRANSMITTER.
Refer to "THERMAL TRANSMITTER CHECK" (EL-93).

NG → Repair or replace.

OK ↓

A

CHECK HARNESS.

1. Disconnect combination meter connector **(M40)** and thermal transmitter connector.
2. Check harness for open or short between combination meter terminal **(6)** and thermal transmitter terminal **(1)**.
Continuity should exist.
3. Check continuity between combination meter terminal **(6)** and ground.
Continuity should not exist.

NG → Repair harness or connector.

OK ↓

Thermal transmitter is OK.

GI
MA
EM
LC
EC
FE
CL
MT
AT
TF
PD
FA
RA
BR
ST
RS
BT
HA
EL
IDX

METER AND GAUGES

Electrical Components Inspection

METER/GAUGE RESISTANCE CHECK

1. Disconnect FPC connector. Refer to EL-86.
2. Check resistance between installation screws of meter/gauge.

Screws		Resistance Ω
Tachometer	Fuel/Temp. gauge	
A - C	A - C	Approx. 70 - Approx. 140
B - D	B - C	Approx. 90 - Approx. 170

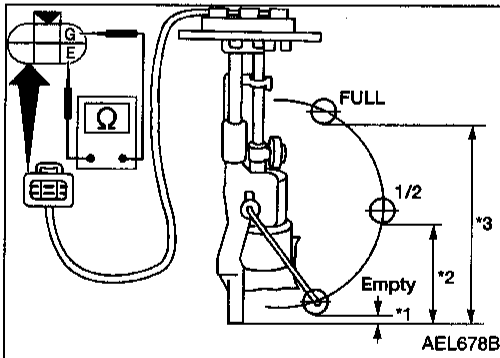
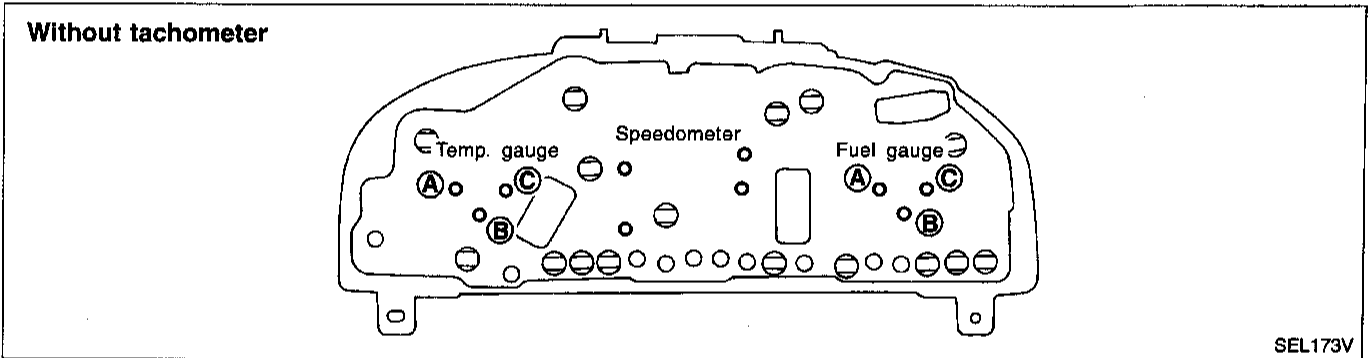
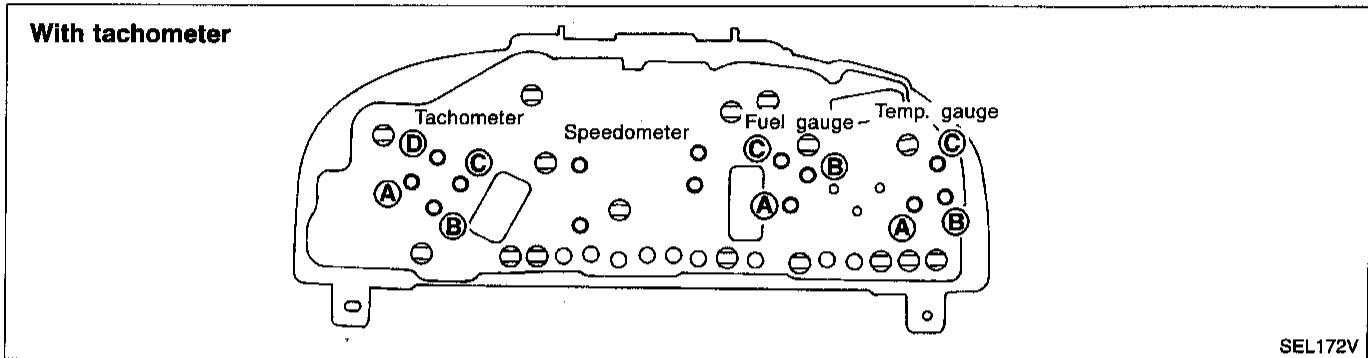

FUEL TANK GAUGE UNIT CHECK

- For removal, refer to FE section.
- Check the resistance between terminals **G** and **E**.

Ohmmeter (+)	Ohmmeter (-)	Float position		Resistance value (Ω)
		mm	(in)	
G	E	*1	Empty	8 (0.31)
		*2	1/2	115 (4.53)
		*3	Full	241 (9.49)
				Approx. 4 - 6

*1 and *3: When float rod is in contact with stopper.

METER AND GAUGES

Electrical Components Inspection (Cont'd)

THERMAL TRANSMITTER CHECK

Check the resistance between the terminals of thermal transmitter and body ground.

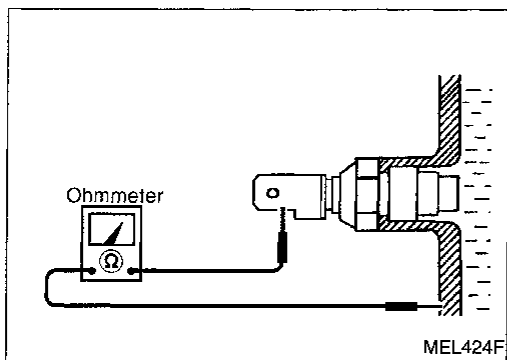

Water temperature	Resistance
60°C (140°F)	Approx. 167 - 211Ω
100°C (212°F)	Approx. 47 - 53Ω

GI

MA

EM

LC

VEHICLE SPEED SENSOR SIGNAL CHECK

1. Remove vehicle speed sensor from transmission.
2. Turn vehicle speed sensor pinion quickly and measure voltage between terminals ① and ②.

EC

FE

CL

MT

AT

TF

PD

FA

RA

BR

ST

RS

BT

HA

EL

IDX

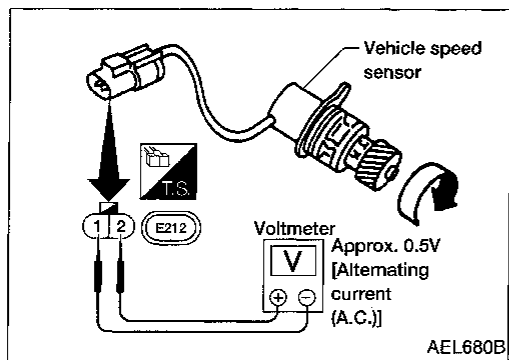

System Description

With the ignition switch in the ON or START position, power is supplied:

- through 10A fuse (No. 11, located in the fuse block [J/B])
- to combination meter terminal 29 and
- to 4WD switch terminal 1.

Ground is supplied:

- through body grounds M14 and M68
- to combination meter terminals 26 and 33.

Ground is supplied:

- through body grounds M14 and M68
- to fuel tank gauge unit terminal E and
- seat belt buckle switch terminal 2.

Ground is supplied:

- through body grounds E12 and E54
- to brake fluid level switch terminal 2 and
- to washer fluid level switch terminal -.

AIR BAG WARNING LAMP

During prove out or when an air bag malfunction occurs, the ground path is interrupted:

- from the air bag diagnosis sensor unit terminal 15
- to combination meter terminal 5.

Ground is supplied:

- through combination meter terminal 26.

With power and ground supplied, the air bag warning lamp (LEDs) illuminate.

For further information, refer to RS section ("TROUBLE DIAGNOSES").

LOW FUEL LEVEL WARNING LAMP

The amount of fuel in the fuel tank is determined by the fuel level sensor in the fuel tank. A signal is sent from fuel tank gauge unit terminal S to combination meter terminal 1. The fuel level sensor will illuminate the low fuel level warning lamp when the fuel level is low.

With power and ground supplied, the low fuel level warning lamp illuminates.

ABS WARNING LAMP

During prove out or when an ABS malfunction occurs, ground is supplied:

- from ABS control unit terminal 2 (with 2-wheel ABS) or ABS actuator and electric unit (control unit) terminal 21 (with 4-wheel ABS)
- to combination meter terminals 35 or 36

With power and ground supplied, the ABS warning lamp illuminates.

For further information, refer to BR section ("Self-diagnosis", "TROUBLE DIAGNOSES").

4WD INDICATOR LAMP

When the 4WD switch is in the 4H or 4L position, power is supplied:

- from the 4WD switch terminal 1
- to combination meter terminal 18.

Ground is supplied:

- through combination meter terminal 33.

With power and ground supplied, the 4WD indicator lamp illuminates.

LOW OIL PRESSURE WARNING LAMP

Low oil pressure causes oil pressure switch terminal 1 to provide ground to combination meter terminal 29.

With power and ground supplied, the low oil pressure warning lamp illuminates.

CHARGE WARNING LAMP

During prove out or when a generator malfunction occurs, ground is supplied:

- from generator terminal 3
- to combination meter terminals 27 and 19.

With power and ground supplied, the charge warning lamp and brake lamp illuminate.

WARNING LAMPS

System Description (Cont'd)

BRAKE WARNING LAMP

When the parking brake is applied, or the brake fluid level is low, ground is supplied:

- from parking brake switch terminal ① or
- brake fluid level switch terminal ①
- to combination meter terminal ⑪.

With power and ground supplied, the brake warning lamp illuminates.

SEAT BELT WARNING LAMP

When the driver's seat belt is unfastened, ground is supplied:

- from seat belt buckle switch terminal ①
- to combination meter terminal ⑫.

With power and ground supplied, the seat belt warning lamp illuminates.

WASHER WARNING LAMP

When the washer fluid level is low, ground is supplied:

- from washer fluid level switch terminal ⊕
- to combination meter terminal ⑬.

With power and ground supplied, the washer warning lamp illuminates.

MALFUNCTION INDICATOR LAMP

During prove out or when an engine control malfunction occurs, ground is supplied:

- from ECM terminal ⑱
- to combination meter terminal ⑮.

With power and ground supplied, the malfunction indicator lamp illuminates.

For further information, refer to EC section ["Malfunction Indicator Lamp (MIL)", "ON BOARD DIAGNOSTIC SYSTEM DESCRIPTION"].

GI

MA

EM

LC

EC

FE

CL

MT

AT

TF

PD

FA

RA

BR

ST

RS

BT

HA

EL

IDX

WARNING LAMPS

Schematic

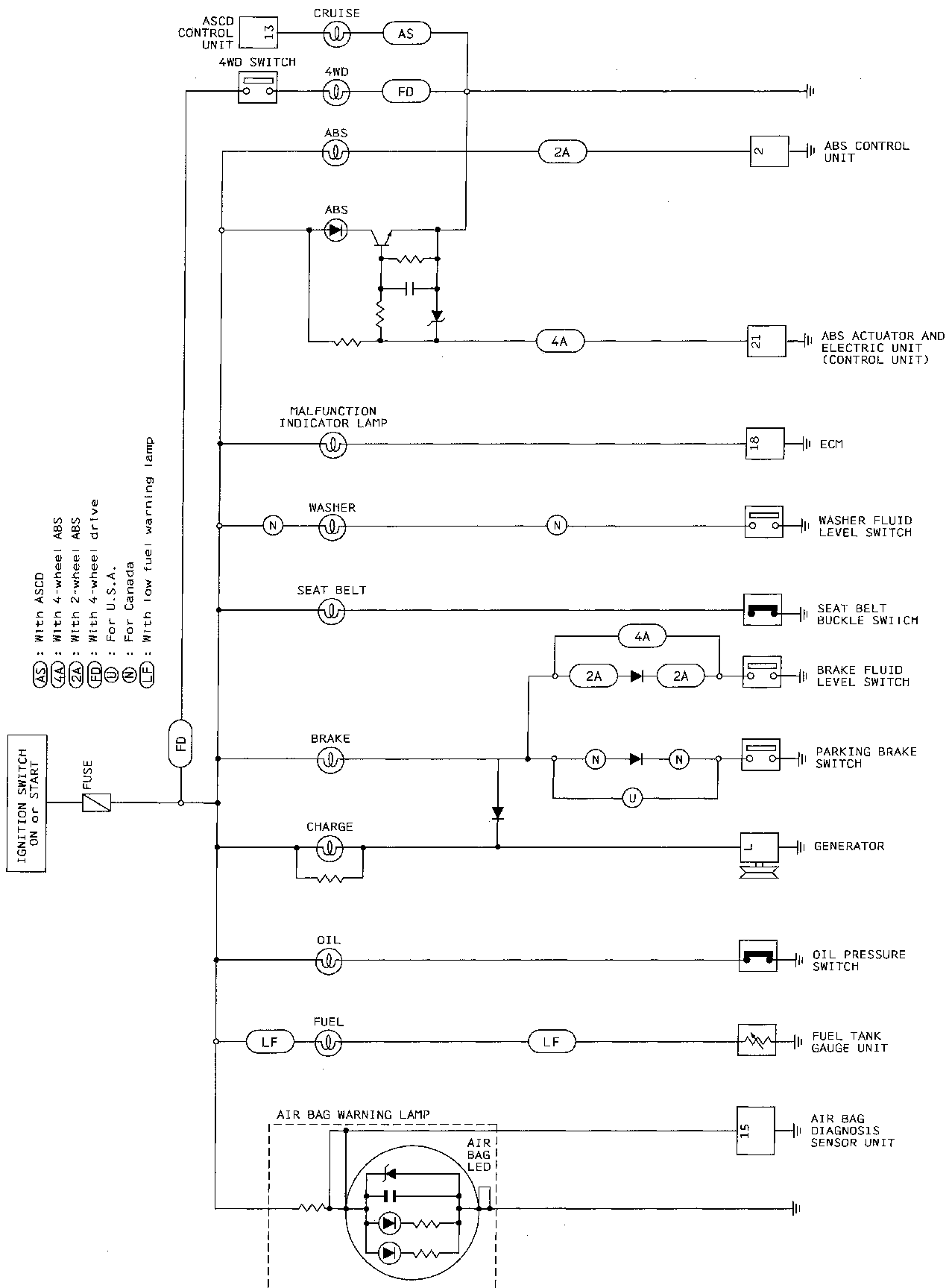

WARNING LAMPS

Wiring Diagram — WARN —

EL-WARN-01

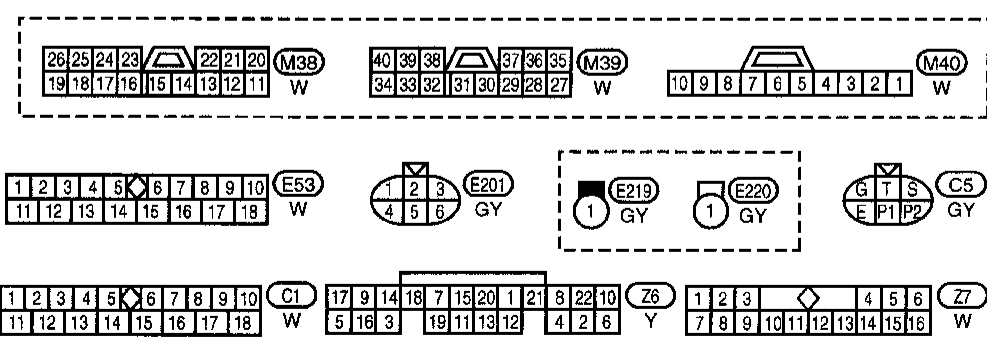
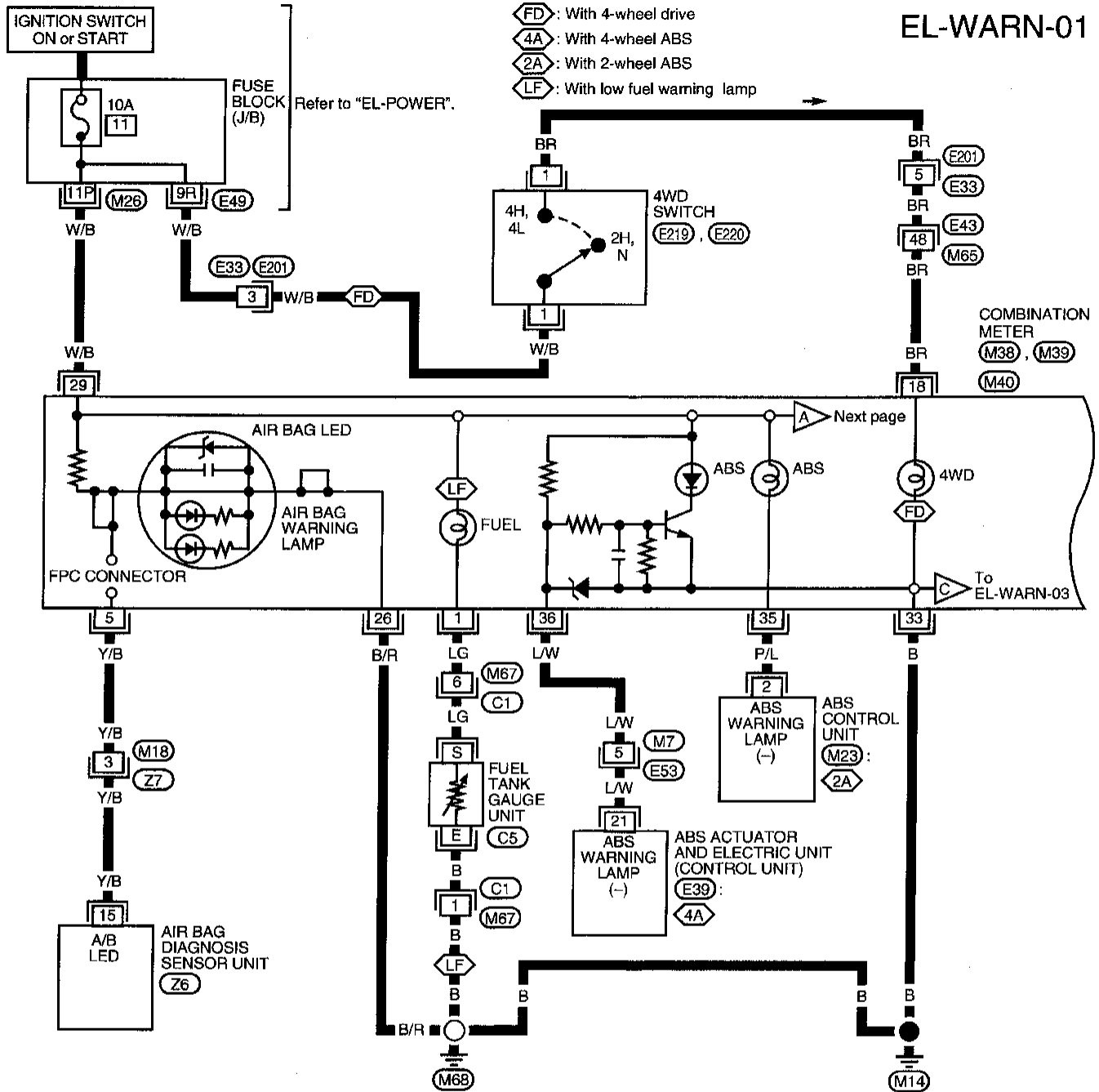

Refer to last page (Foldout page).

- M65, E43
- M23
- M26
- E39
- E49

GI
MA
EM
LC
EC
FE
CL
MT
AT
TF
PD
FA
RA
BR
ST
RS
BT
HA
EL
IDX

WARNING LAMPS

Wiring Diagram — WARN — (Cont'd)

EL-WARN-02

- ◊4A : With 4-wheel ABS
- ◊2A : With 2-wheel ABS
- ◊U : For U.S.A.
- ◊N : For Canada

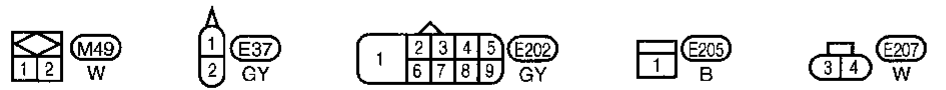
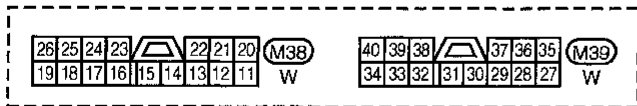
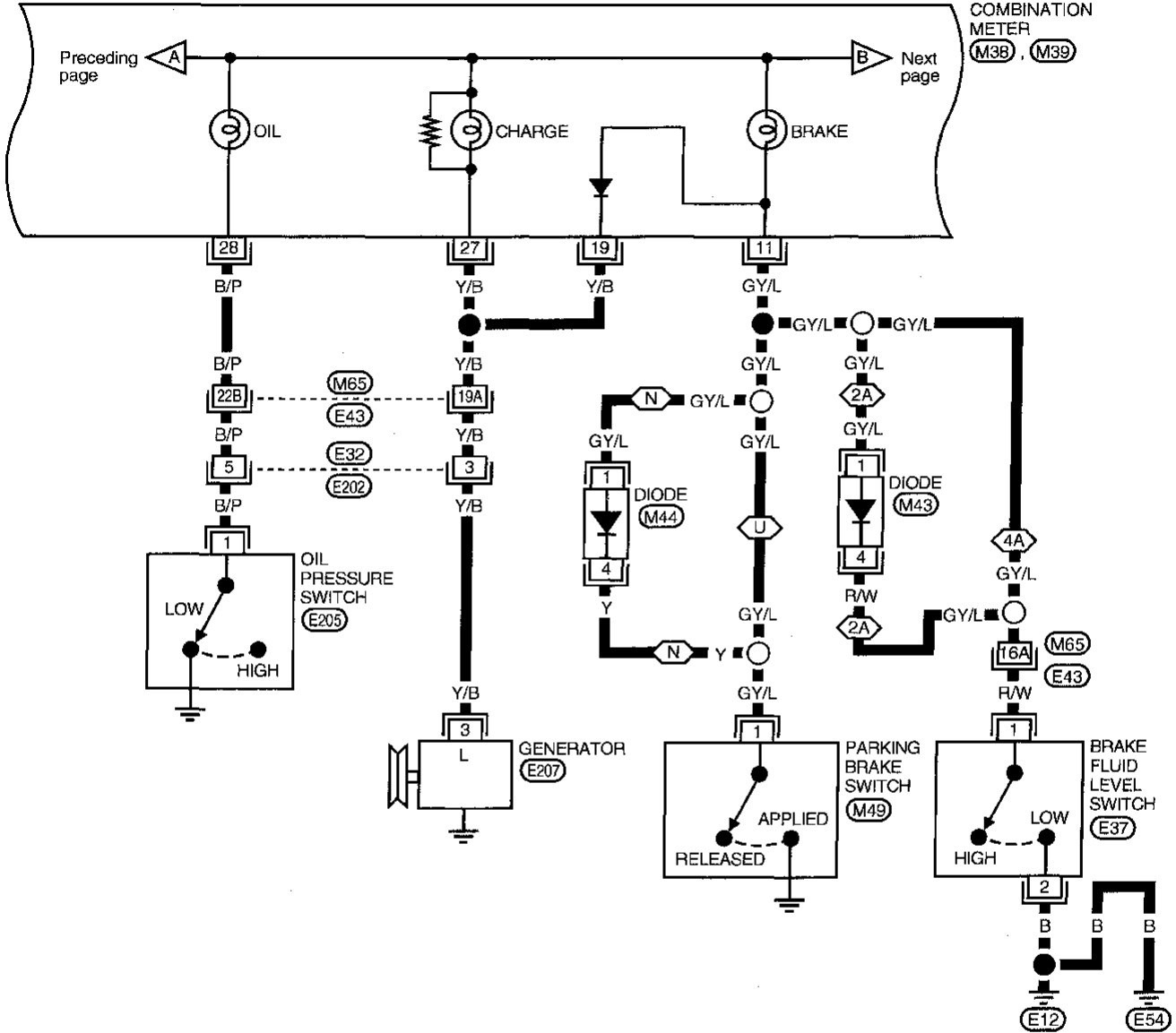

Refer to last page (Foldout page).
M65, E43

WARNING LAMPS

Wiring Diagram — WARN — (Cont'd)

EL-WARN-03

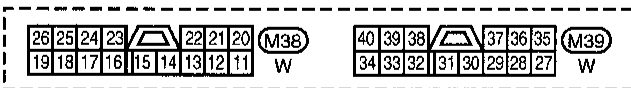
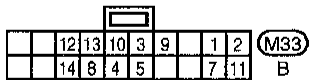
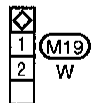
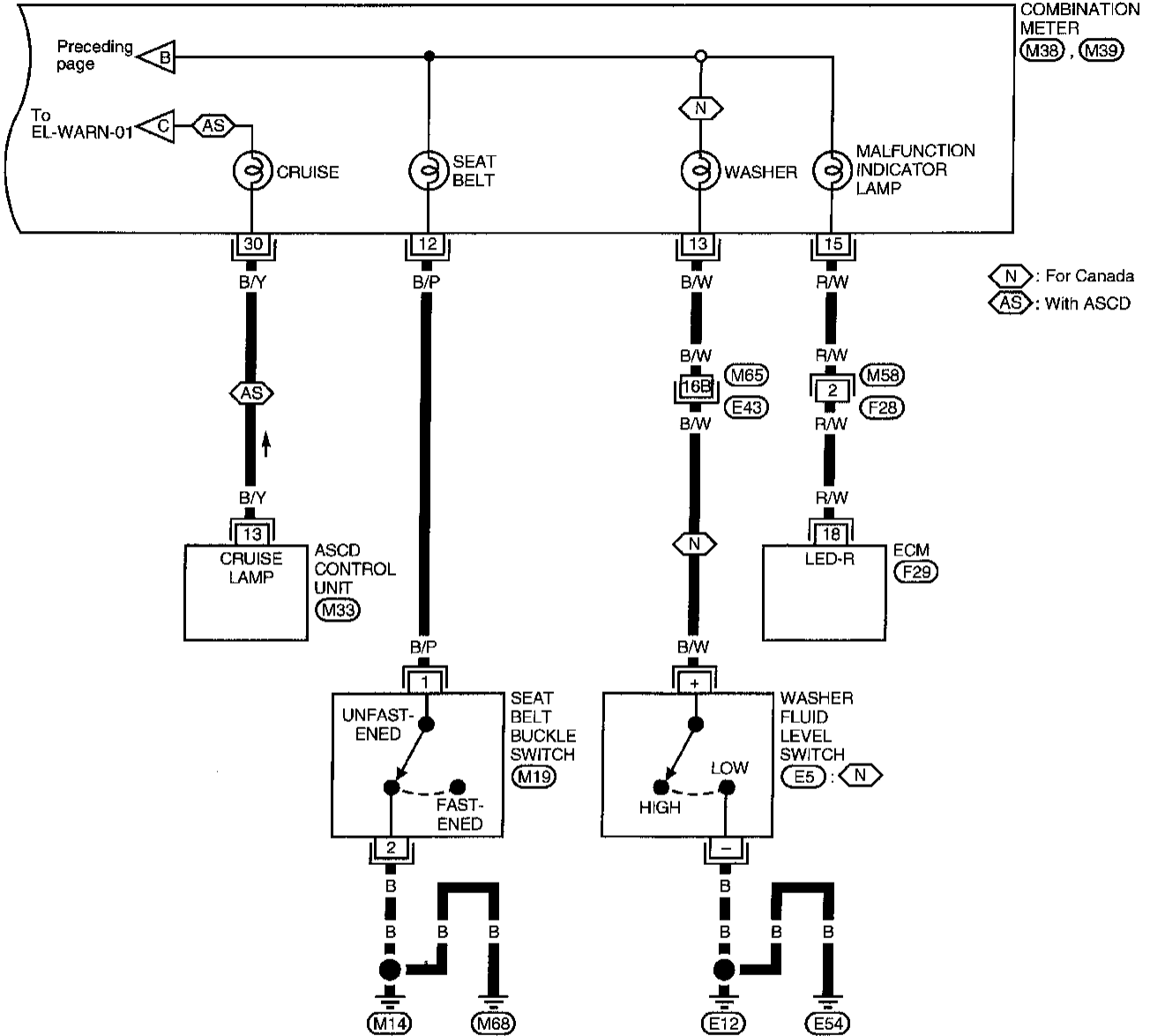

Refer to last page (Foldout page).

(M65), (E43)

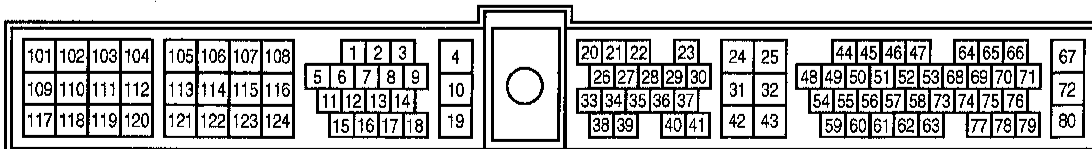

GI
MA
EM
LC
EC
FE
CL
MT
AT
TF
PD
FA
RA
BR
ST
RS
BT
HA
EL
IDX

WARNING LAMPS

Electrical Components Inspection

FUEL WARNING LAMP SENSOR CHECK

- It will take a short time for the bulb to light.

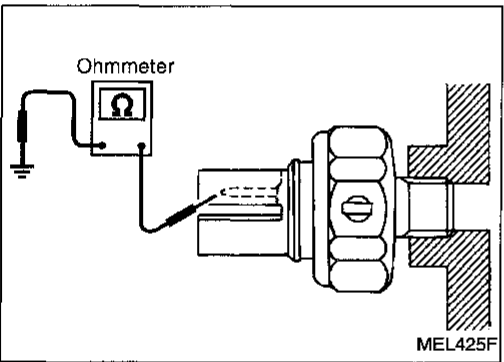
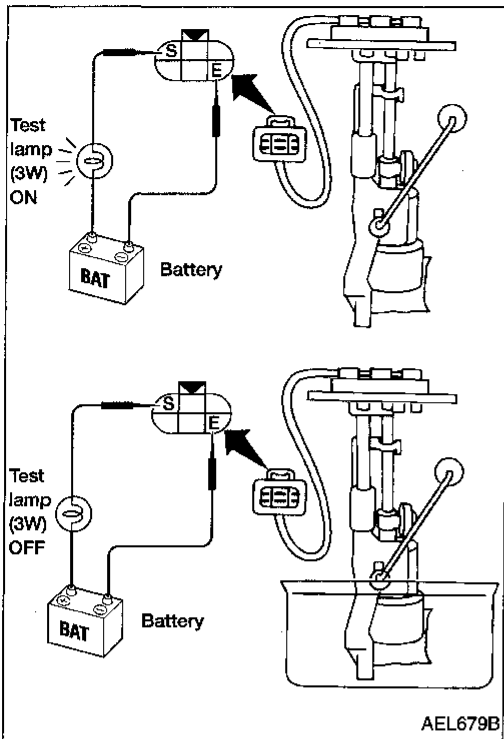

OIL PRESSURE SWITCH CHECK

	Oil pressure kPa (kg/cm ² , psi)	Continuity
Engine start	More than 10 - 20 (0.1 - 0.2, 1 - 3)	NO
Engine stop	Less than 10 - 20 (0.1 - 0.2, 1 - 3)	YES

Check the continuity between the terminals of oil pressure switch and body ground.

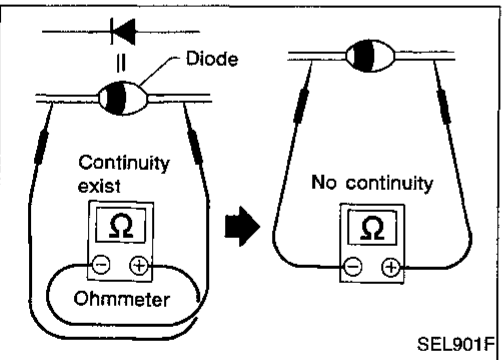

DIODE CHECK

- Check continuity using an ohmmeter.
- Diode is functioning properly if test results are as shown in the figure at left.

NOTE: Specification may vary depending on the type of tester. Before performing this inspection, be sure to refer to the instruction manual for the tester to be used.

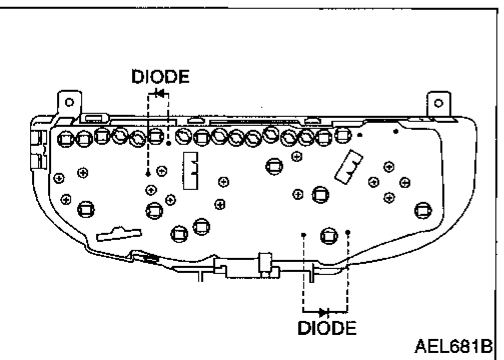

- Diodes for warning lamps are built into the combination meter printed circuit.

A/T INDICATOR

Wiring Diagram — AT/IND —

EL-AT/IND-01

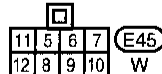
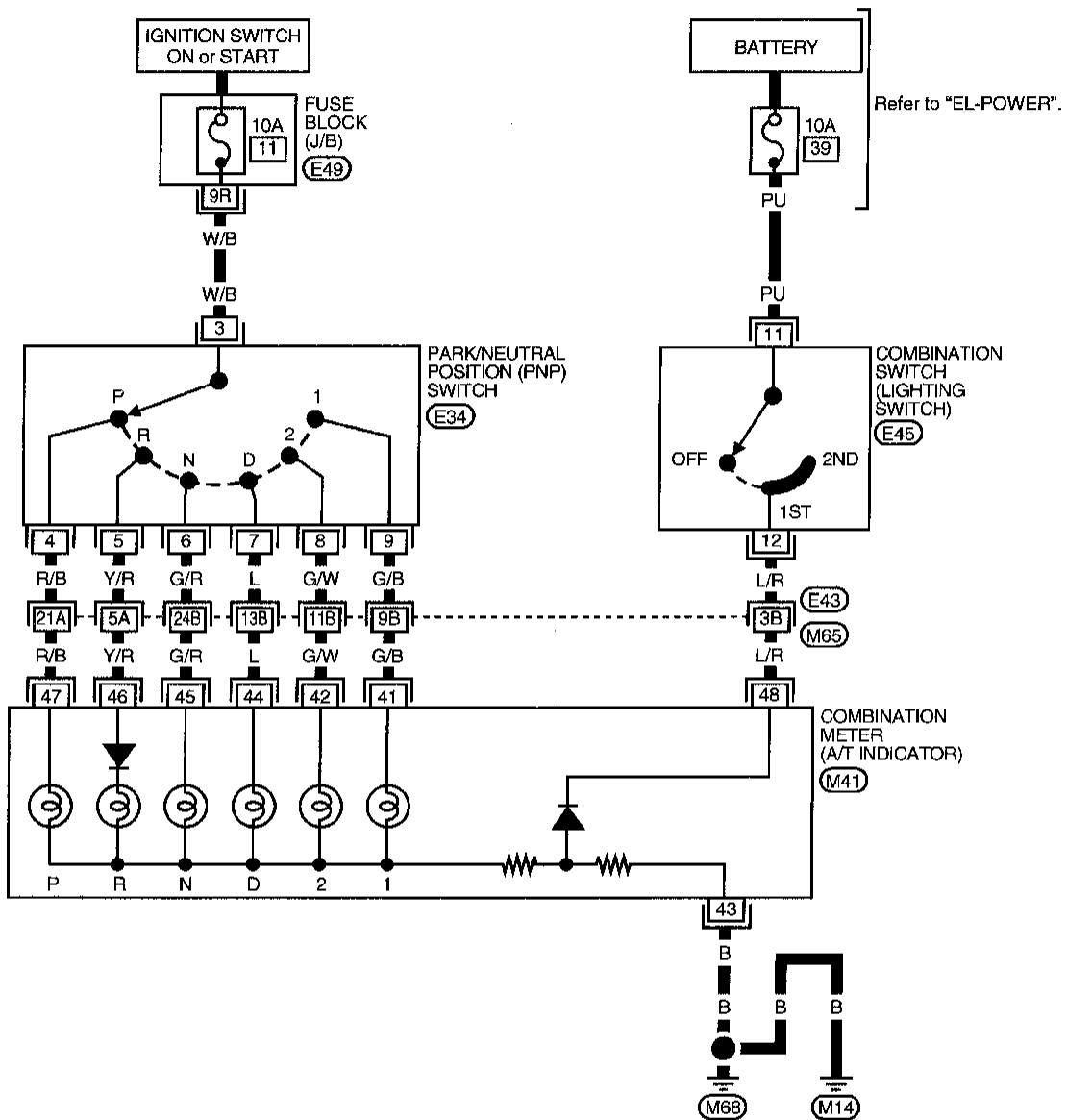

Refer to last page (Foldout page).
 (M68), (E43)

WARNING CHIME

Component Parts and Harness Connector Location

Fuse block (J/B)

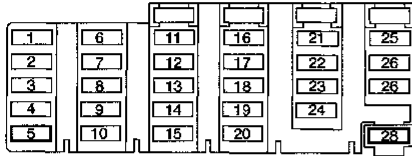

Fuse and fusible link box

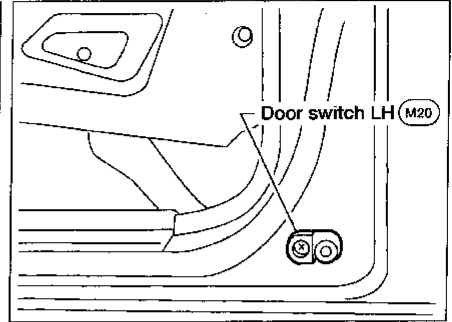
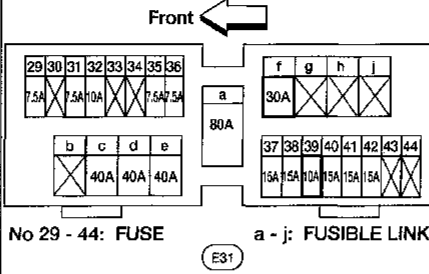

View with steering column covers removed

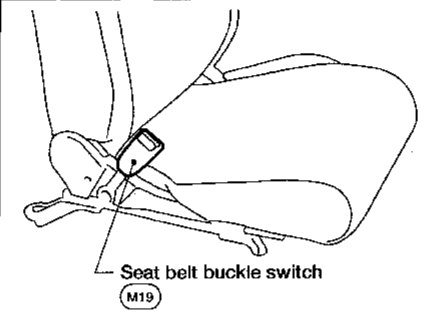
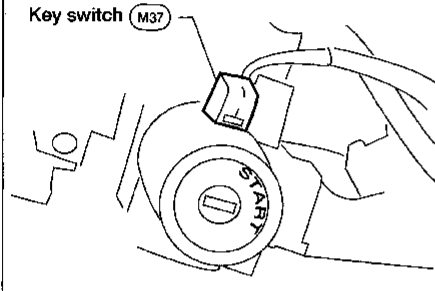

View with instrument lower panel driver's side removed

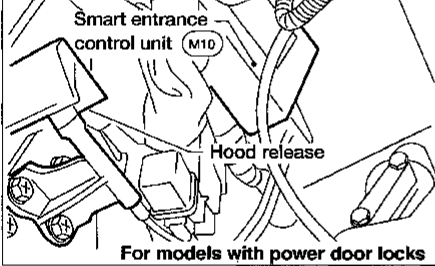

View with instrument lower panel driver's side removed

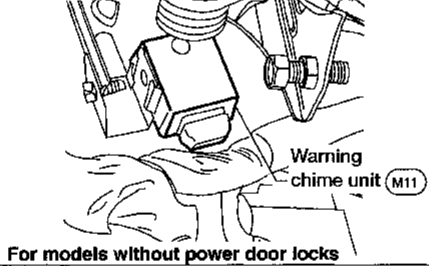

System Description

GI

MODELS WITH POWER DOOR LOCKS

MA

The warning chime is integral with the smart entrance control unit, which controls its operation.

Power is supplied at all times:

- through 7.5A fuse [No. 28], located in the fuse block (J/B)]
- to key switch terminal ①.

EM

Power is supplied at all times:

- through 10A fuse (No. 39], located in the fuse and fusible link box)
- to lighting switch terminal ⑪.

LC

Power is supplied at all times:

- through 30A fusible link (letter f], located in the fuse and fusible link box)
- to circuit breaker terminal ①
- through circuit breaker terminal ②
- to smart entrance control unit terminal ①.

EC

With the ignition switch in the ON or START position, power is supplied:

- through 7.5A fuse [No. 5], located in the fuse block (J/B)]
- to smart entrance control unit terminal ⑪.

FE

Ground is supplied to smart entrance control unit terminal ⑩ through body grounds M14 and M68.

CL

When a signal, or combination of signals, is received by the smart entrance control unit, the warning chime will sound.

Ignition key warning chime

MT

With the key in the ignition key cylinder, the ignition switch in the OFF or ACC position, and the driver's door open, the warning chime will sound. A battery positive voltage is supplied:

- from key switch terminal ②
- to smart entrance control unit terminal ⑭.

AT

Ground is supplied:

- from door switch LH terminal ②
- to smart entrance control unit terminal ⑮.

TF

Door switch LH terminal ③ is grounded through body grounds M14 and M68.

PD

Light warning chime

With ignition switch in the OFF or ACC position, driver's door open, and lighting switch in 1ST or 2ND position, the warning chime will sound. A battery positive voltage is supplied:

- from lighting switch terminal ⑫
- to smart entrance control unit terminal ⑮.

FA

Ground is supplied:

- from door switch LH terminal ②
- to smart entrance control unit terminal ⑮.

RA

Door switch LH terminal ③ is grounded through body grounds M14 and M68.

BR

Seat belt warning chime

The warning chime sounds for about 6 seconds when ignition switch is turned from OFF to ON and seat belt is unfastened.

ST

Ground is supplied:

- from seat belt buckle switch terminal ①
- to smart entrance control unit terminal ⑳.

RS

Seat belt buckle switch terminal ② is grounded through body grounds M14 and M68.

BT

HA

EL

IDX

WARNING CHIME

System Description (Cont'd)

MODELS WITHOUT POWER DOOR LOCKS

The warning chime is integral with the warning chime unit, which controls its operation.

Power is supplied at all times:

- through 7.5A fuse [No. 28], located in the fuse block (J/B)
- to key switch terminal ①.

Power is supplied at all times:

- through 10A fuse (No. 39), located in the fuse and fusible link box)
- to lighting switch terminal ⑪.

With the ignition switch in the ON or START position, power is supplied:

- through 7.5A fuse [No. 5], located in the fuse block (J/B)
- to warning chime unit terminal ①.

Ground is supplied to warning chime unit terminal ⑧ through body grounds M14 and M68.

When a signal, or combination of signals, is received by the warning chime unit, the warning chime will sound.

Ignition key warning chime

With the key in the ignition key cylinder, the ignition switch in the OFF or ACC position, and the driver's door open, the warning chime will sound. A battery positive voltage is supplied:

- from key switch terminal ②
- to warning chime unit terminal ⑤.

Ground is supplied:

- to warning chime unit terminal ⑦
- from door switch LH terminal ②.

Door switch LH terminal ③ is grounded through body grounds M14 and M68.

Light warning chime

With ignition switch OFF or ACC position, driver's door open, and lighting switch in 1ST or 2ND position, the warning chime will sound. A battery positive voltage is supplied:

- from lighting switch terminal ⑫
- to warning chime unit terminal ④.

Ground is supplied:

- to warning chime unit terminal ⑦
- from door switch LH terminal ②.

Door switch LH terminal ③ is grounded through body grounds M14 and M68.

Seat belt warning chime.

The warning chime will sound for approximately 6 seconds when ignition switch is turned from OFF to ON and seat belt is unfastened.

Ground is supplied:

- to warning chime unit terminal ②
- from seat belt buckle switch terminal ①.

Seat belt buckle switch terminal ② is grounded through body grounds M14 and M68.

WARNING CHIME

Wiring Diagram — CHIME —

MODELS WITH POWER DOOR LOCKS

EL-CHIME-01

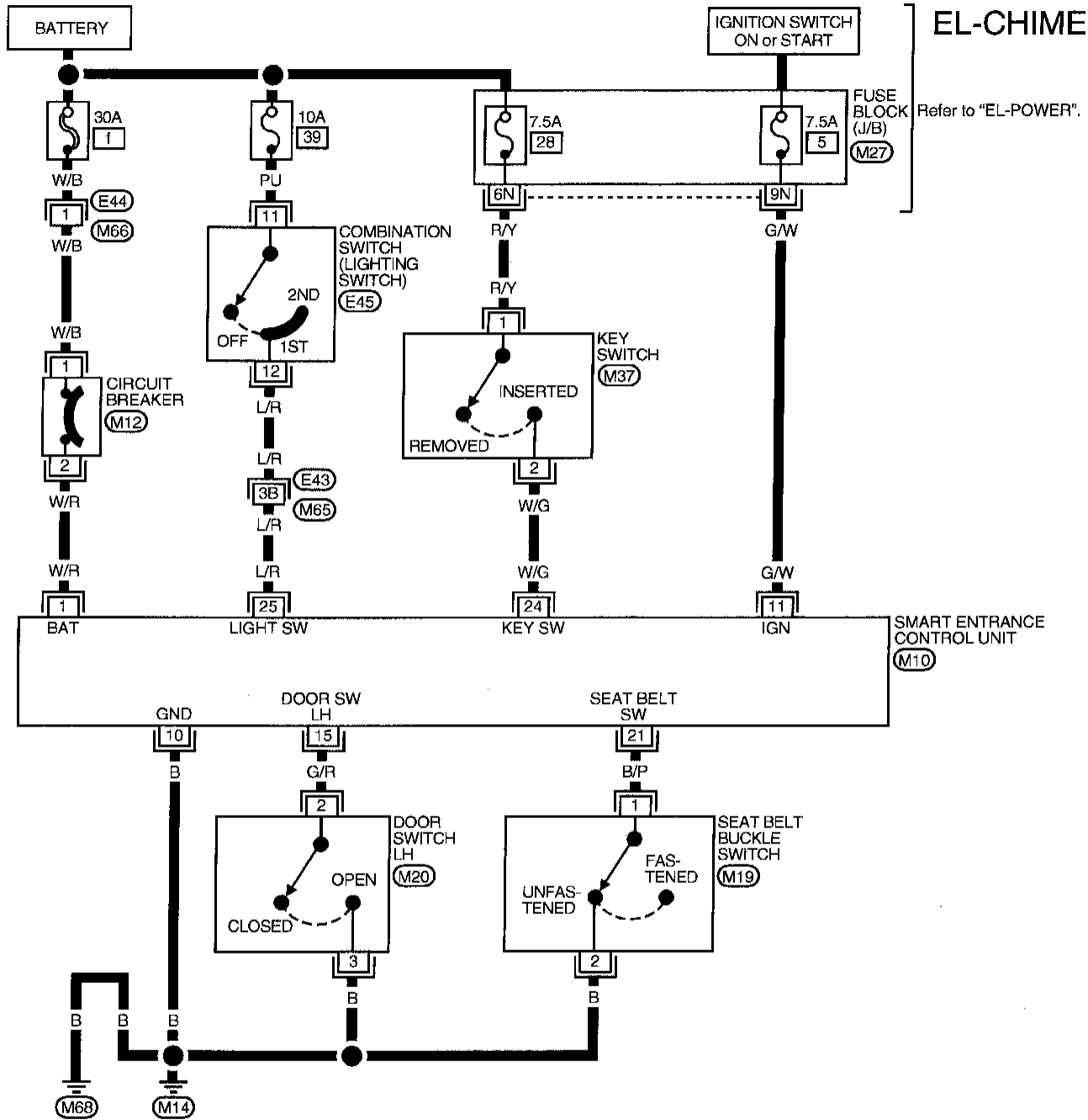

Refer to last page (Foldout page).

(M65), (E43)

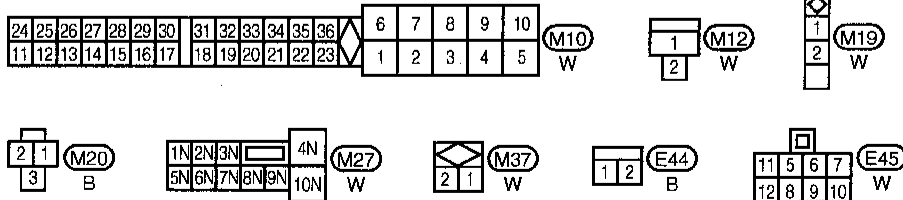

WARNING CHIME

Wiring Diagram — CHIME — (Cont'd)

MODELS WITHOUT POWER DOOR LOCKS

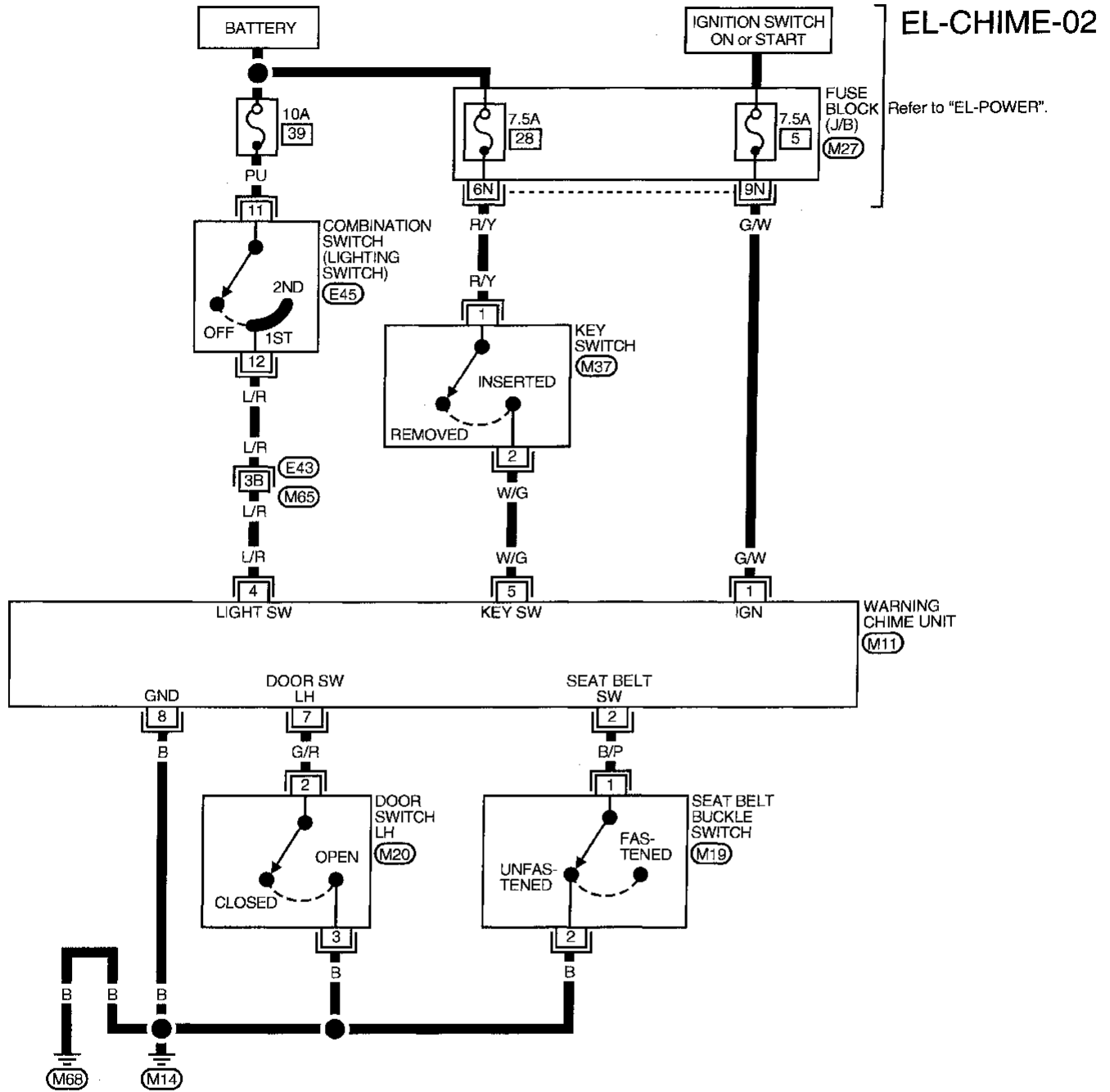

Refer to last page (Foldout page).

(M65), (E43)

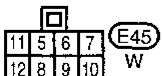
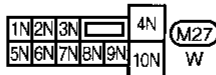
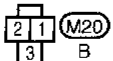
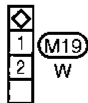
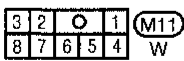

WARNING CHIME

Trouble Diagnoses

SYMPTOM CHART

REFERENCE PAGE	EL-108	EL-109	EL-110	EL-111	EL-112
SYMPTOM	MAIN POWER SUPPLY AND GROUND CIRCUIT CHECK	DIAGNOSTIC PROCEDURE 1 (Lighting switch input signal check)	DIAGNOSTIC PROCEDURE 2 (Key switch input signal check)	DIAGNOSTIC PROCEDURE 3 (Seat belt buckle switch input signal check)	DIAGNOSTIC PROCEDURE 4 (Driver side door switch input signal check)
Light warning chime does not activate.	X	X			X
Ignition key warning chime does not activate.	X		X		X
Seat belt warning chime does not activate.	X			X	
All warning chimes do not activate.	X				

GI
 MA
 EM
 LC
 EC
 FE
 CL
 MT
 AT
 TF
 PD
 FA
 RA
 BR
 ST
 RS
 BT
 HA
 EL
 IDX

WARNING CHIME

Trouble Diagnoses (Cont'd)

MAIN POWER SUPPLY AND GROUND CIRCUIT CHECK

Main power supply circuit check

- Models with power door locks

Terminals		Ignition switch position		
⊕	⊖	OFF	ACC	ON
①	Ground	Battery voltage	Battery voltage	Battery voltage
⑪	Ground	0V	0V	Battery voltage

- Models without power door locks

Terminals		Battery voltage existence condition		
		Ignition switch position		
⊕	⊖	OFF	ACC	ON
①	Ground	0V	0V	Battery voltage

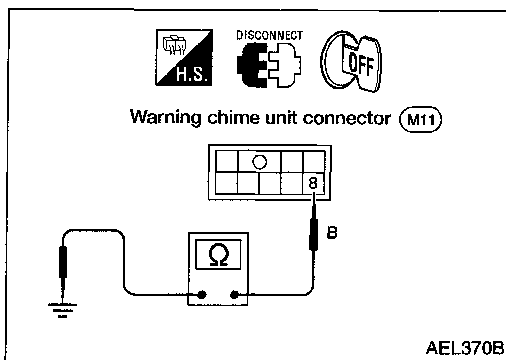
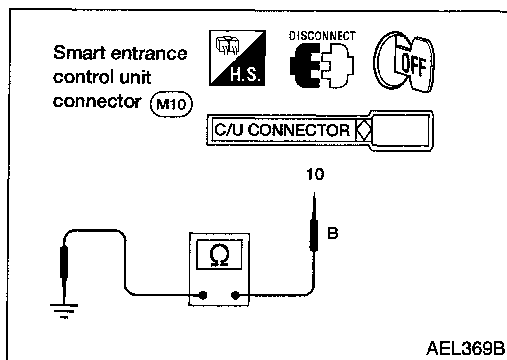
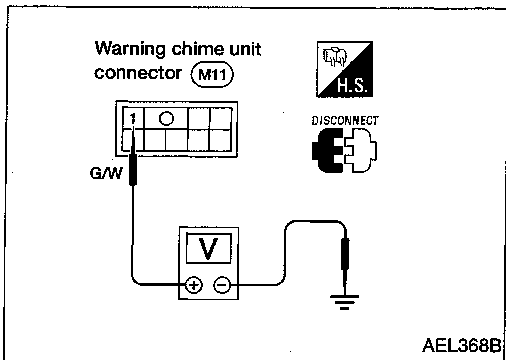
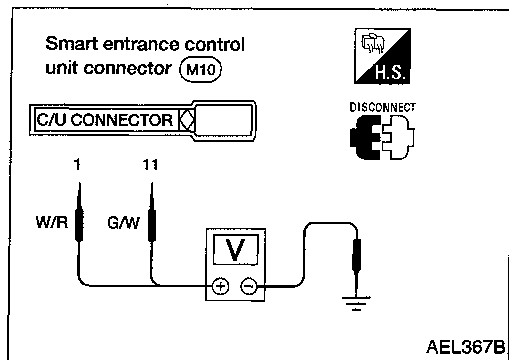

Ground circuit check

- Models with power door locks

Terminals	Continuity
⑩ - Ground	Yes

- Models without power door locks

Terminals	Continuity
⑧ - Ground	Yes

WARNING CHIME

Trouble Diagnoses (Cont'd)

DIAGNOSTIC PROCEDURE 1

(Lighting switch input signal check)

Models with power door locks

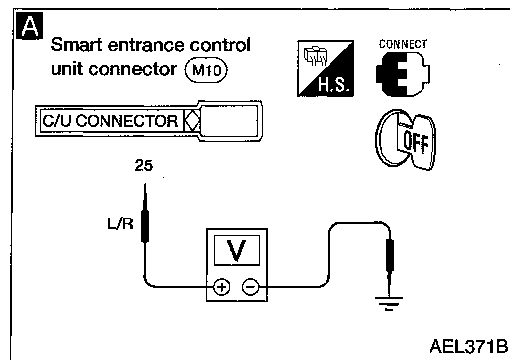

A

CHECK LIGHTING SWITCH INPUT SIGNAL.

Check voltage between control unit terminal (25) and ground.

Condition of lighting switch	Voltage [V]
1ST or 2ND	Approx. 12
OFF	0

NG

Check the following.

- 10A fuse (No. 39), located in the fuse and fusible link box
- Harness for open or short between control unit and lighting switch

OK

Go to Diagnostic Procedure 4, EL-112.

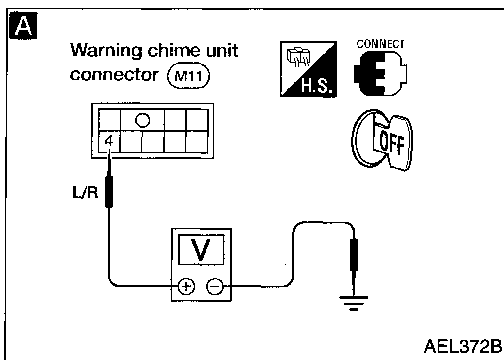

Models without power door locks

A

CHECK LIGHTING SWITCH INPUT SIGNAL.

Check voltage between warning chime unit terminal (4) and ground.

Condition of lighting switch	Voltage [V]
1ST or 2ND	Approx. 12
OFF	0

NG

Check the following.

- 10A fuse (No. 39), located in the fuse and fusible link box
- Harness for open or short between warning chime unit and lighting switch

OK

Go to Diagnostic Procedure 4, EL-112.

GI

MA

EM

LC

EC

FE

CL

MT

AT

TF

PD

FA

RA

BR

ST

RS

BT

HA

EL

IDX

WARNING CHIME

Trouble Diagnoses (Cont'd)

DIAGNOSTIC PROCEDURE 2

(Key switch input signal check)

Models with power door locks

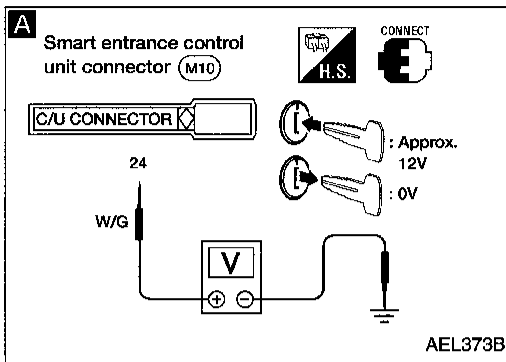

A

CHECK KEY SWITCH INPUT SIGNAL.
Check voltage between control unit terminal (24) and ground.

Condition of key switch	Voltage [V]
Key is inserted.	Approx. 12
Key is removed.	0

NG

Check the following.

- Key switch
Refer to "Electrical Components Inspection" (EL-113).
- 7.5A fuse [No. 28], located in fuse block (J/B)
- Harness for open or short between key switch and fuse
- Harness for open or short between control unit and key switch

OK

Go to Diagnostic Procedure 4, EL-112.

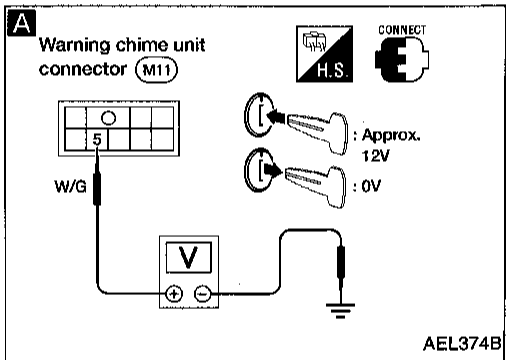

Models without power door locks

A

CHECK KEY SWITCH INPUT SIGNAL.
Check voltage between warning chime unit terminal (5) and ground.

Condition of key switch	Voltage [V]
Key is inserted.	Approx. 12
Key is removed.	0

NG

Check the following.

- Key switch
Refer to "Electrical Components Inspection" (EL-113).
- 7.5A fuse [No. 28], located in fuse block (J/B)
- Harness for open or short between key switch and fuse
- Harness for open or short between warning chime unit and key switch

OK

Go to Diagnostic Procedure 4, EL-112.

WARNING CHIME

Trouble Diagnoses (Cont'd)

DIAGNOSTIC PROCEDURE 3

(Seat belt buckle switch input signal check)

Models with power door locks

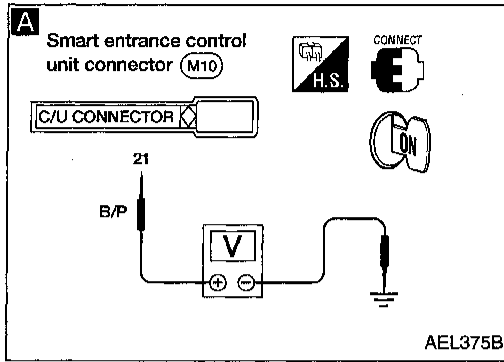

A

CHECK SEAT BELT BUCKLE SWITCH INPUT SIGNAL.

1. Turn ignition switch ON.
2. Check voltage between control unit terminal (21) and ground.

Condition of seat belt buckle switch	Voltage [V]
Fastened	Approx. 12
Unfastened	0

NG

Check the following.

- Seat belt buckle switch
Refer to "Electrical Components Inspection" (EL-113).
- Seat belt buckle switch ground circuit
- Harness for open or short between control unit and seat belt buckle switch

OK

Replace smart entrance control unit.

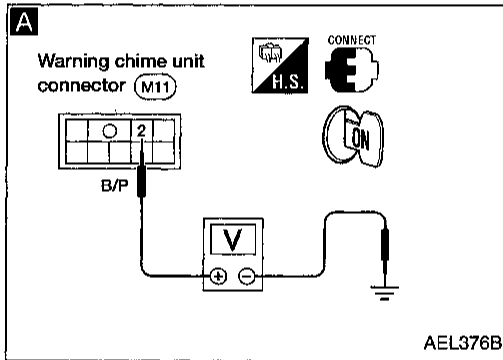

Models without power door locks

A

CHECK SEAT BELT BUCKLE SWITCH INPUT SIGNAL.

1. Turn ignition switch ON.
2. Check voltage between warning chime unit terminal (2) and ground.

Condition of seat belt buckle switch	Voltage [V]
Fastened	Approx. 12
Unfastened	0

NG

Check the following.

- Seat belt buckle switch
Refer to "Electrical Components Inspection" (EL-113).
- Seat belt buckle switch ground circuit
- Harness for open or short between warning chime unit and seat belt buckle switch

OK

Replace smart entrance control unit.

GI
MA
EM
LC
EC
FE
CL
MT
AT
TF
PD
FA
RA
BR
ST
RS
BT
HA
EL
IDX

WARNING CHIME

Trouble Diagnoses (Cont'd)

DIAGNOSTIC PROCEDURE 4

(Driver side door switch input signal check)

Models with power door locks

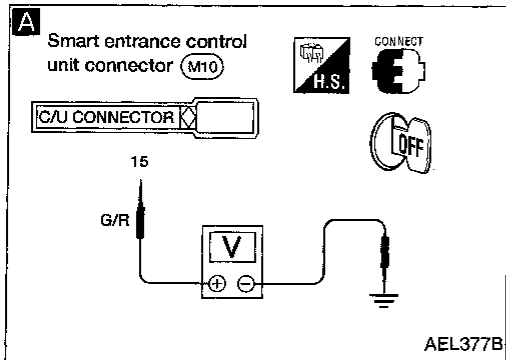

A

CHECK DOOR SWITCH INPUT SIGNAL.
Check voltage between control unit terminal (15) and ground.

Condition of driver's door	Voltage [V]
Driver side door is closed.	Approx. 12
Driver side door is open.	0

NG

Check the following.

- Driver side door switch
Refer to "Electrical Components Inspection" (EL-113).
- Door switch ground condition
- Harness for open or short between control unit and door switch

OK

Replace smart entrance control unit.

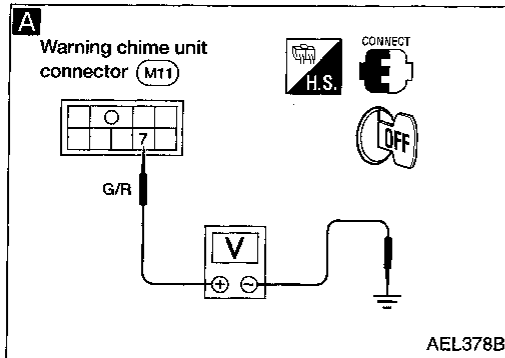

Models without power door locks

A

CHECK DOOR SWITCH INPUT SIGNAL.
Check voltage between warning chime unit terminal (7) and ground.

Condition of driver's door	Voltage [V]
Driver side door is closed.	Approx. 12
Driver side door is open.	0

NG

Check the following.

- Driver side door switch
Refer to "Electrical Components Inspection" (EL-113).
- Door switch ground circuit
- Harness for open or short between warning chime unit and door switch

OK

Replace warning chime unit.

WARNING CHIME

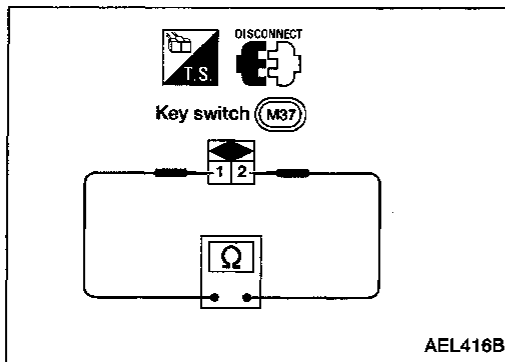

Electrical Components Inspection

KEY SWITCH (insert)

Check continuity between terminals when key is inserted in ignition key cylinder and key is removed from ignition key cylinder.

Terminal No.	Condition	Continuity
① - ②	Key is inserted.	Yes
	Key is removed.	No

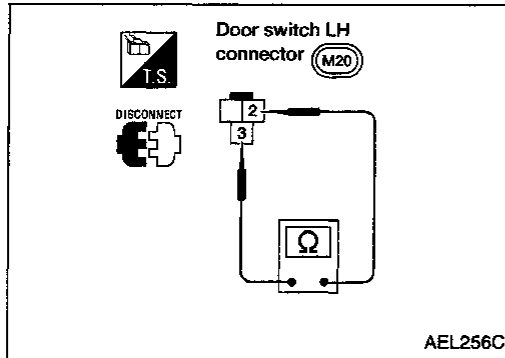

DRIVER SIDE DOOR SWITCH

Check continuity between terminals when door switch is pushed and released.

Terminal No.	Condition	Continuity
② - ③	Door switch is pushed.	No
	Door switch is released.	Yes

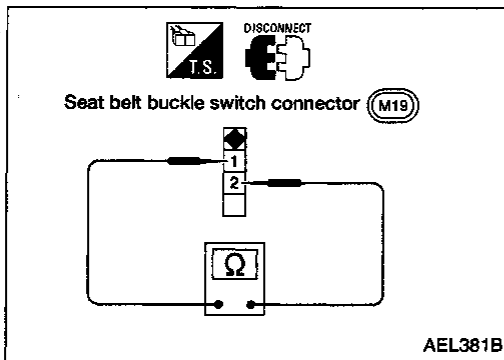

SEAT BELT BUCKLE SWITCH

Check continuity between terminals when seat belt is fastened and unfastened.

Terminal No.	Condition	Continuity
① - ②	Seat belt is fastened.	No
	Seat belt is unfastened.	Yes

GI
MA
EM
LC
EC
FE
CL
MT
AT
TF
PD
FA
RA
BR
ST
RS
BT
HA
EL
IDX

System Description

WIPER OPERATION

The wiper switch is controlled by a lever built into the combination switch.

There are three wiper switch positions:

- LO speed
- HI speed
- INT (Intermittent) (if equipped).

With the ignition switch in the ON or START position, power is supplied:

- through 20A fuse [No. 6], located in the fuse block (J/B)]
- to wiper motor terminal (B) and
- to wiper amplifier terminal (6) (with intermittent wipers).

Low and high speed wiper operation

Ground is supplied to wiper switch terminal (17) through body grounds (E12) and (E54).

When the wiper switch is placed in the LO position, ground is supplied:

- through terminal (14) of the wiper switch
- to wiper motor terminal (L).

With power and ground supplied, the wiper motor operates at low speed.

When the wiper switch is placed in the HI position, ground is supplied:

- through terminal (16) of the wiper switch
- to wiper motor terminal (H).

With power and ground supplied, the wiper motor operates at high speed.

Auto stop operation

With wiper switch turned OFF, wiper motor will continue to operate until wiper arms reach windshield base.

When wiper arms are not located at base of windshield with wiper switch OFF, ground is supplied:

- from terminal (14) of the wiper switch
- to wiper motor terminal (L), in order to continue wiper motor operation at low speed.

Ground is also supplied:

- through terminal (13) of the wiper switch
- to wiper amplifier terminal (4) (with intermittent wipers)
- through terminal (8) of the wiper amplifier (with intermittent wipers)
- to wiper motor terminal (P)
- through terminal (E) of the wiper motor, and
- through body grounds (E12) and (E54).

When wiper arms reach base of windshield, wiper motor terminals (P) and (B) are connected instead of terminals (P) and (E). Wiper motor will then stop wiper arms at the PARK position.

Intermittent operation

The wiper motor operates the wiper arms one time at low speed at a set interval of approximately 3 to 13 seconds. This feature is controlled by the wiper amplifier.

When the wiper switch is placed in the INT position, ground is supplied:

- to wiper amplifier terminal (1)
- from wiper switch terminal (15)
- through body grounds (E12) and (E54)
- to wiper motor terminal (L)
- through the wiper switch terminal (14)
- to wiper switch terminal (13)
- through wiper amplifier terminal (4)
- to wiper amplifier terminal (7)
- through body grounds (E12) and (E54).

The desired interval time is input:

- to wiper amplifier terminal (2)
- from wiper switch terminal (19)
- to wiper switch terminal (20)
- through body grounds (E12) and (E54).

The wiper motor operates at low speed at the desired time interval.

FRONT WIPER AND WASHER

System Description (Cont'd)

WASHER OPERATION

With the ignition switch in the ON or START position, power is supplied:

- through 20A fuse [No. 6], located in the fuse block (J/B)
- to washer motor terminal (+).

When the lever is pulled to the WASH position, ground is supplied:

- to washer motor terminal (-), and
- to wiper amplifier terminal (5) (with intermittent wipers)
- from terminal (18) of the wiper switch
- through terminal (17) of the wiper switch, and
- through body grounds (E12) and (E54).

With power and ground supplied, the washer motor operates.

When the lever is pulled to the WASH position for one second or more, the wiper motor operates at low speed for approximately 3 seconds to clean windshield. This feature is controlled by the wiper amplifier in the same manner as the intermittent operation on vehicles equipped with intermittent wipers.

GI

MA

EM

LC

EC

FE

CL

MT

AT

TF

PD

FA

RA

BR

ST

RS

BT

HA

EL

IDX

FRONT WIPER AND WASHER

Wiring Diagram — WIPER —

WITH INTERMITTENT WIPERS

EL-WIPER-01

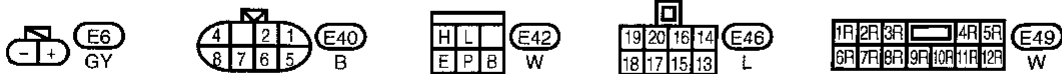
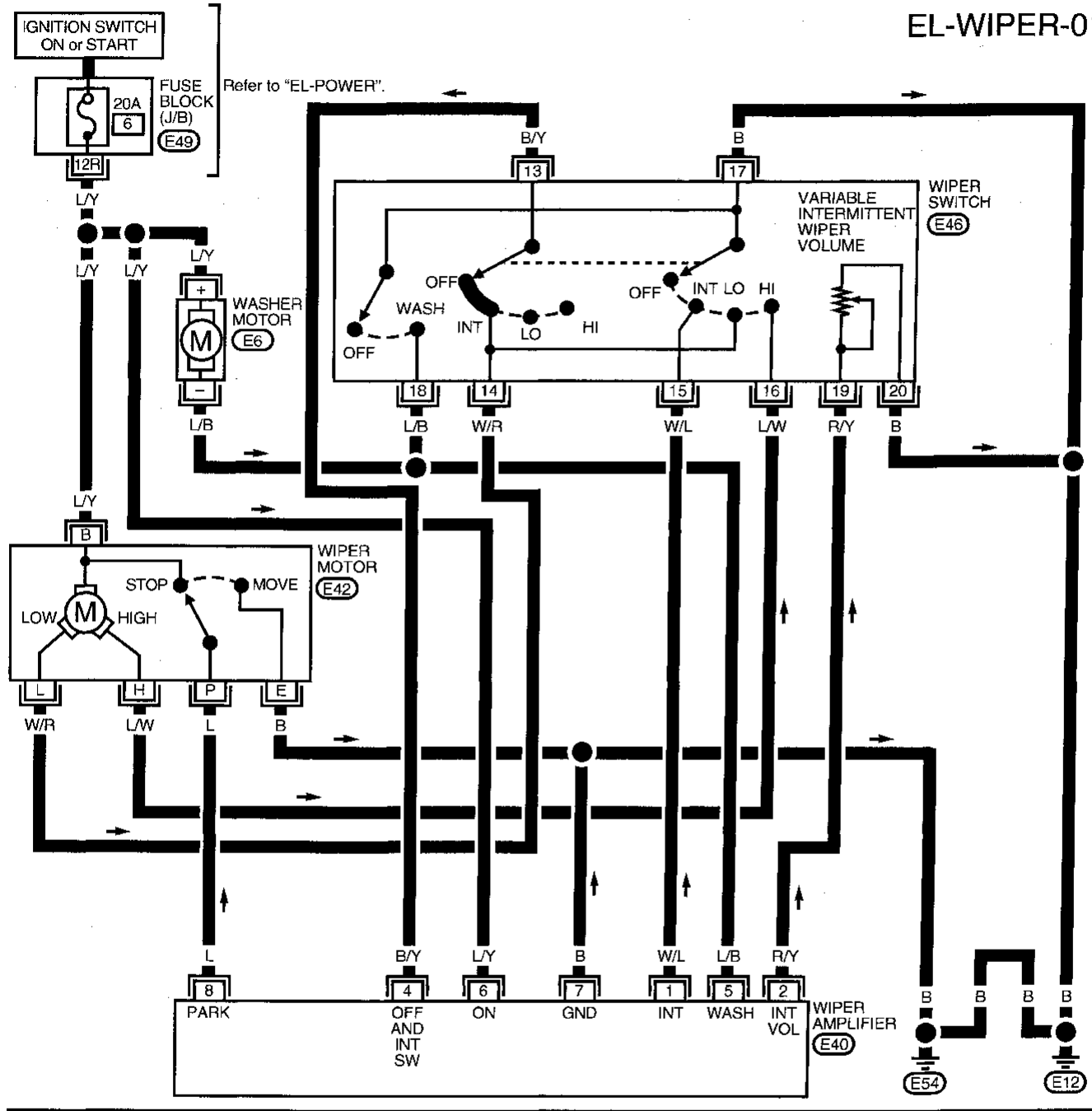

FRONT WIPER AND WASHER

Wiring Diagram — WIPER — (Cont'd)

WITHOUT INTERMITTENT WIPERS

EL-WIPER-02

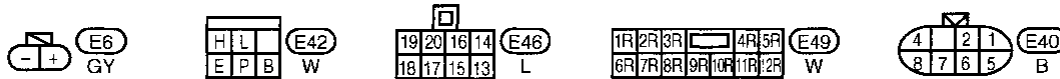
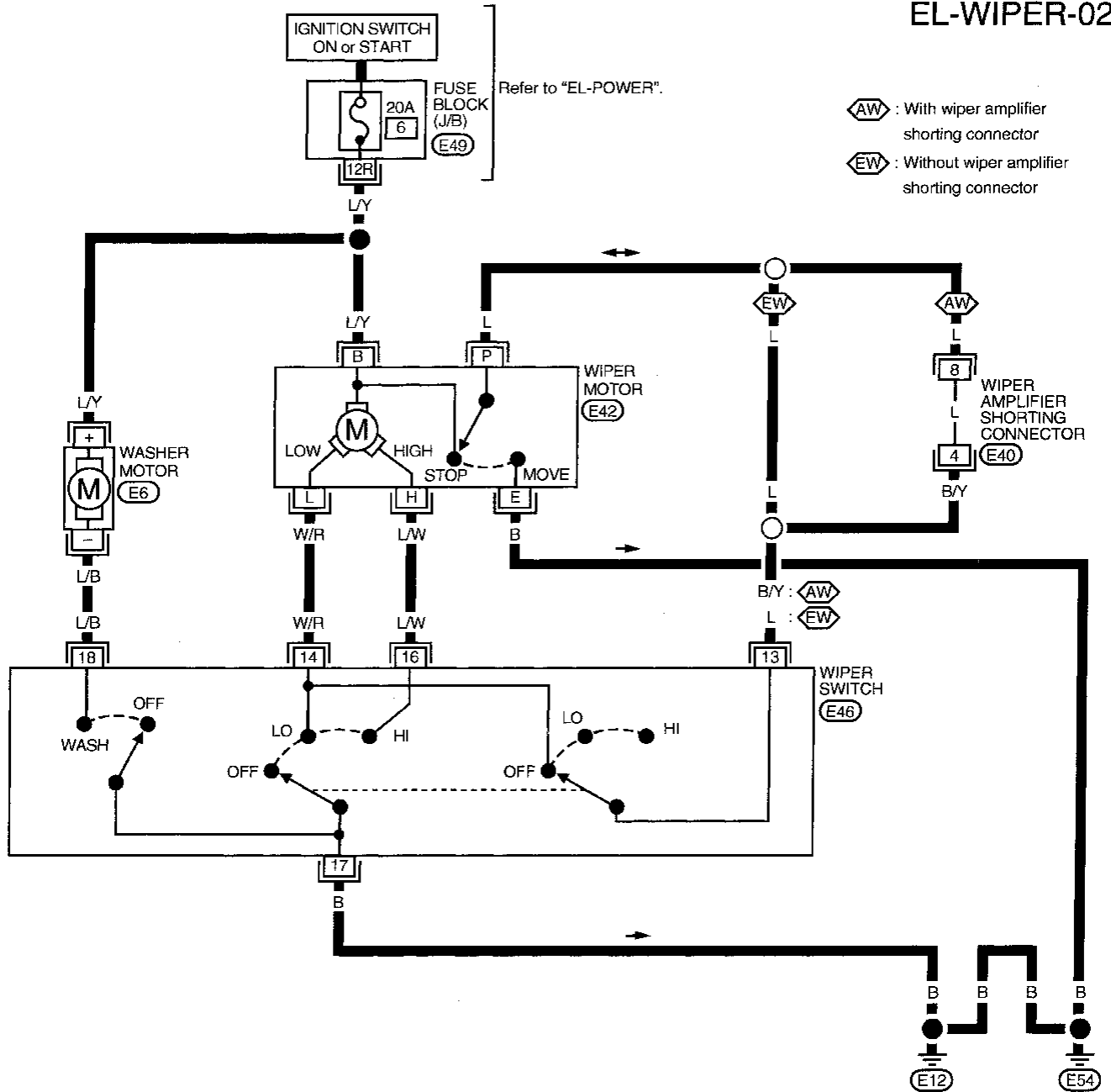

GI
MA
EM
LC
EC
FE
CL
MT
AT
TF
PD
FA
RA
BR
ST
RS
BT
HA
EL
IDX

FRONT WIPER AND WASHER

Trouble Diagnoses (With intermittent wipers)

DIAGNOSTIC PROCEDURE 1

SYMPTOM: Intermittent wiper does not operate.

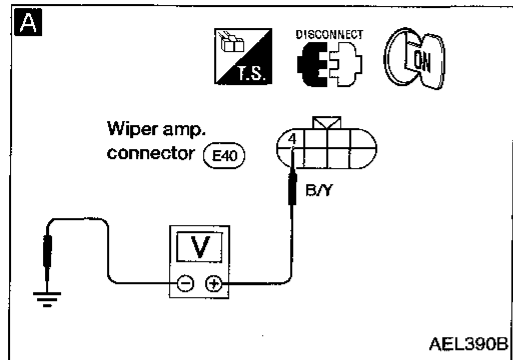

Check whether wiper operates with the wiper switch at LO position.

NG

Check the following.

- 20A fuse [No. 6], located in fuse block (J/B)
- Wiper motor
- Wiper switch
- Harness for open or short

OK

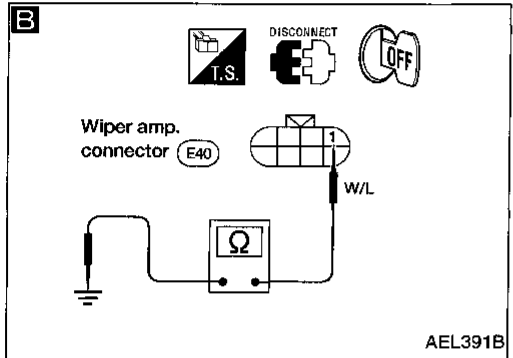

A

1. Turn front wiper switch to OFF.
2. Disconnect wiper amp. connector.
3. Check voltage between wiper amp. terminal ④ and ground.
Battery voltage should exist.

NG

Check the following.

- Wiper switch
- Harness for open or short between wiper amp. terminal ④ and wiper switch terminal ⑬

OK

B

CHECK INTERMITTENT SWITCH INPUT SIGNAL.
Check harness continuity between wiper amp. terminal ① and ground.

NG

Check the following.

- Wiper switch
- Harness for open or short between wiper amp. terminal ① and wiper switch terminal ⑮
- Ground circuit for front wiper switch terminal ⑰

OK

Condition of wiper switch	Continuity
OFF	No
INT	Yes

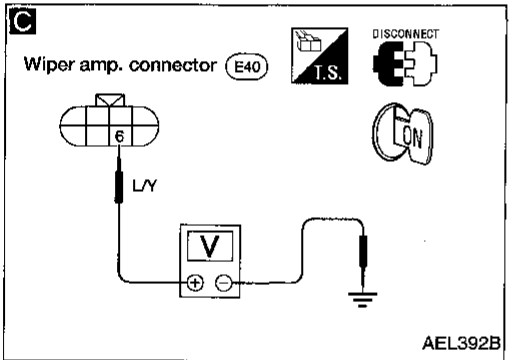

C

CHECK WIPER AMP. POWER SUPPLY CIRCUIT.
Check voltage between wiper amp. terminal ⑥ and ground while ignition switch is in ON.
Battery voltage should exist.

NG

Check the following.

- Harness for open or short between wiper amp. and fuse

OK

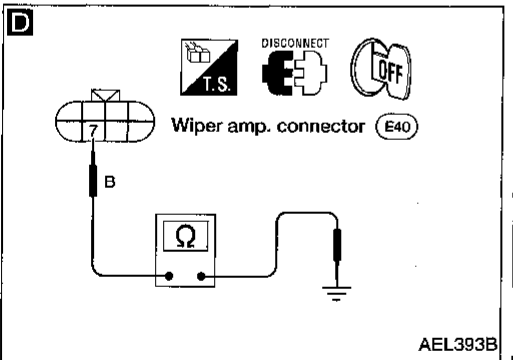

D

CHECK WIPER AMP. GROUND CIRCUIT.
Check harness continuity between wiper amp. terminal ⑦ and body ground.
Continuity should exist.

NG

Repair harness or connector.

OK

Replace wiper amp.

FRONT WIPER AND WASHER

Trouble Diagnoses (With intermittent wipers)

(Cont'd)

DIAGNOSTIC PROCEDURE 2

SYMPTOM: Intermittent time of wiper cannot be adjusted.

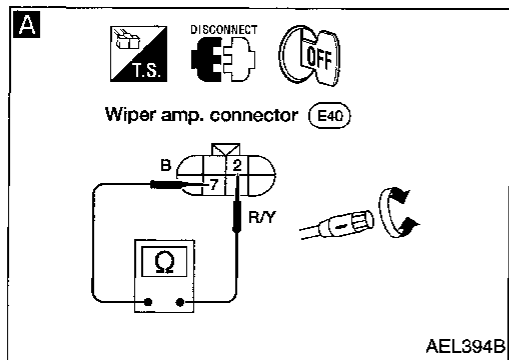

A

CHECK INTERMITTENT WIPER VOLUME INPUT SIGNAL.

1. Disconnect wiper amp. connector.
2. Measure resistance between wiper amp. terminals (2) and (7) while turning intermittent wiper volume.

Position of wiper knob	Resistance [Ω]
S	0
L	Approx. 1 k

OK

Replace wiper amp.

NG

Check the following.

- Intermittent wiper volume
- Harness for open or short between wiper amp. terminal (2) and wiper switch terminal (19)
- Ground circuit for front wiper switch terminal (20)

GI
MA
EM
LC
EC
FE
CL
MT
AT
TF
PD
FA
RA
BR
ST
RS
BT
HA
EL
IDX

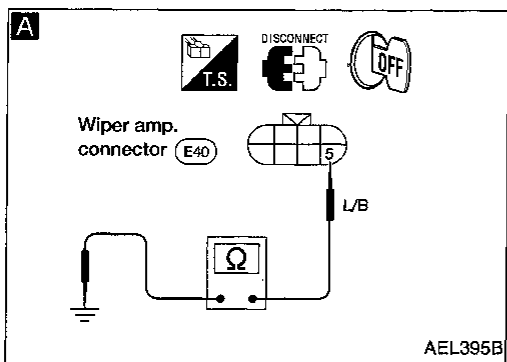

DIAGNOSTIC PROCEDURE 3

SYMPTOM: Wiper and washer activate individually but not in combination.

A

CHECK WASHER SWITCH INPUT SIGNAL.

1. Turn ignition switch and wiper switch OFF.
2. Disconnect wiper amp. connector.
3. Check harness continuity between wiper amp. terminal (5) and ground.

Condition of washer switch	Continuity
OFF	No
ON	Yes

NG

Check harness for open or short between wiper amp. terminal (5) and wiper switch terminal (19).

OK

Go to DIAGNOSTIC PROCEDURE 1.

NG

Replace wiper amp.

FRONT WIPER AND WASHER

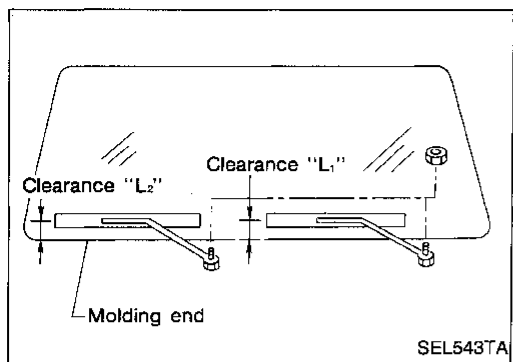

Removal and Installation

WIPER ARMS

1. Prior to wiper arm installation, turn on wiper switch to operate wiper motor and then turn it OFF (Auto Stop).
2. Lift the blade up and then set it down onto glass surface to set the blade center to clearance "L₁" & "L₂" immediately before tightening nut.
3. Eject washer fluid. Turn on wiper switch to operate wiper motor and then turn it OFF.
4. Ensure that wiper blades stop within clearance "L₁" & "L₂".
Clearance "L₁": 25 mm (.98 in)
Clearance "L₂": 25 mm (.98 in)
 - Tighten wiper arm nuts to specified torque.
Front wiper: 13 - 18 N·m (1.3 - 1.8 kg-m, 9 - 13 ft-lb)

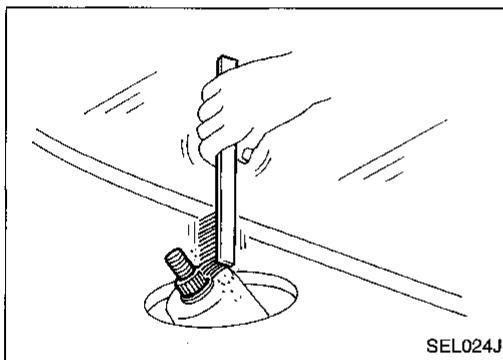

- Before reinstalling wiper arm, clean up the pivot area as illustrated. This will reduce possibility of wiper arm looseness.

WIPER LINKAGE

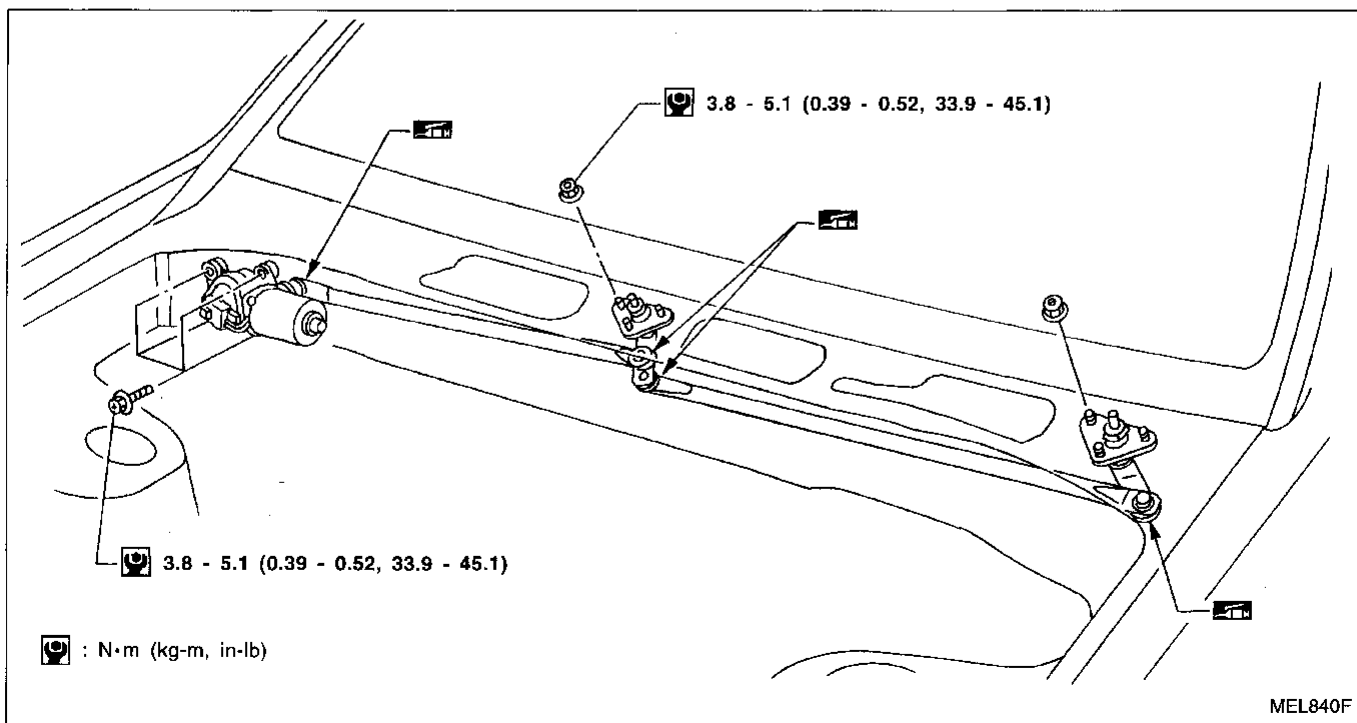

FRONT WIPER AND WASHER

Removal and Installation (Cont'd)

Removal

1. Remove 4 bolts that secure wiper motor.
2. Detach wiper motor from wiper linkage at ball joint.
3. Remove wiper linkage.

Be careful not to break ball joint rubber boot.

Installation

- Grease ball joint portion before installation.
1. Installation is the reverse order of removal.

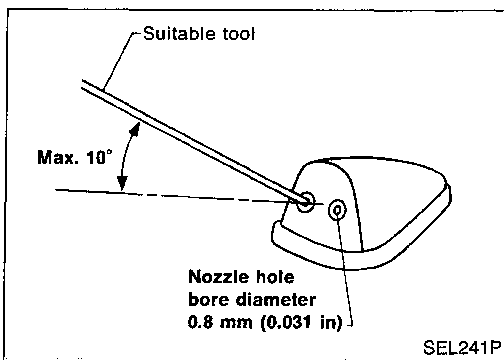

Washer Nozzle Adjustment

- Adjust washer nozzle with suitable tool as shown in the figure at left.

Adjustable range: ±10°

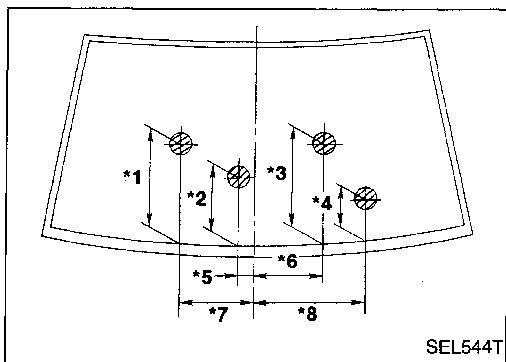

Unit: mm (in)

*1	365 (14.37)	*5	60 (2.36)
*2	215 (8.46)	*6	225 (8.86)
*3	380 (14.96)	*7	210 (8.27)
*4	180 (7.09)	*8	460 (18.11)

*: The diameters of these circles are less than 80 mm (3.15 in).

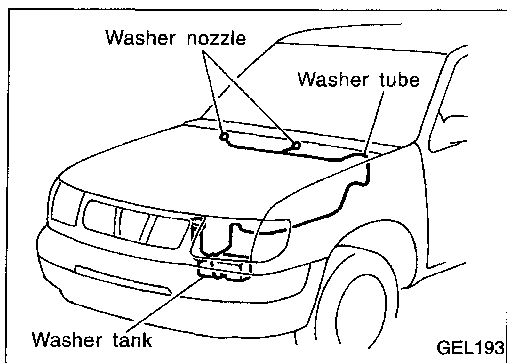

Washer Tube Layout

Wiring Diagram — HORN —

EL-HORN-01

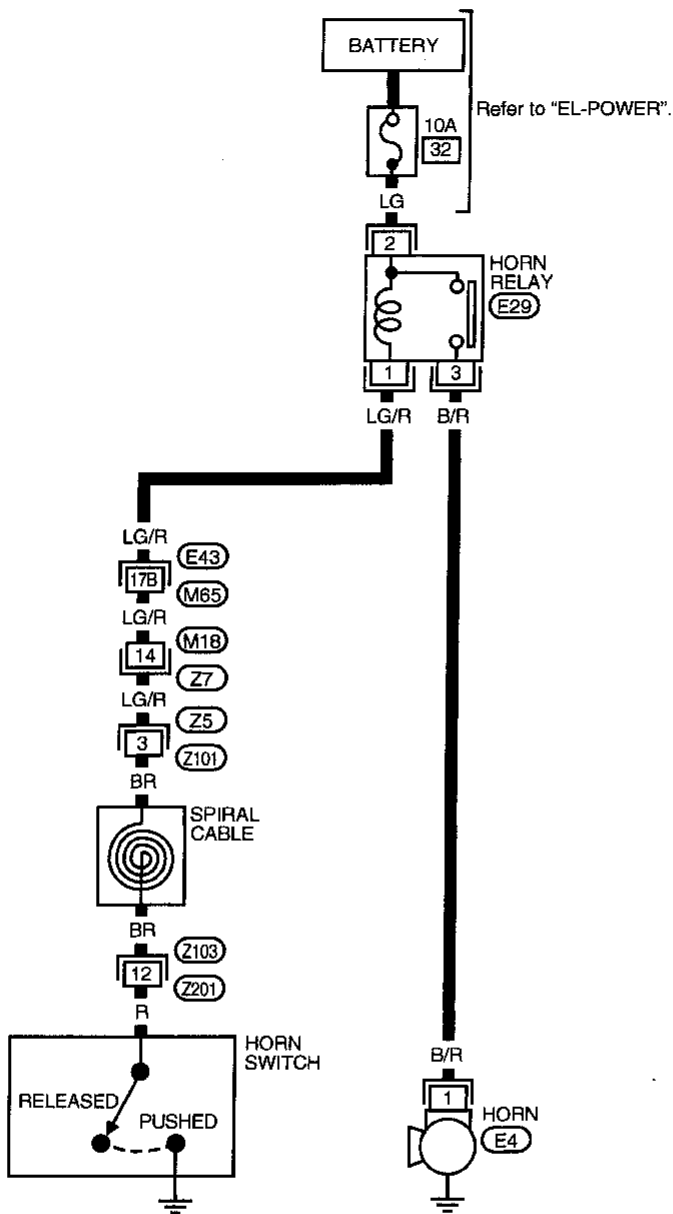

Refer to last page (Foldout page).

(M65) (E43)

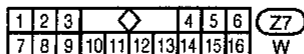
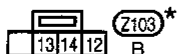
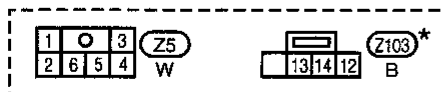
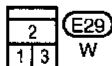

* : This connector is not shown in "HARNESS LAYOUT" of EL section.

CIGARETTE LIGHTER

Wiring Diagram — CIGAR —

EL-CIGAR-01

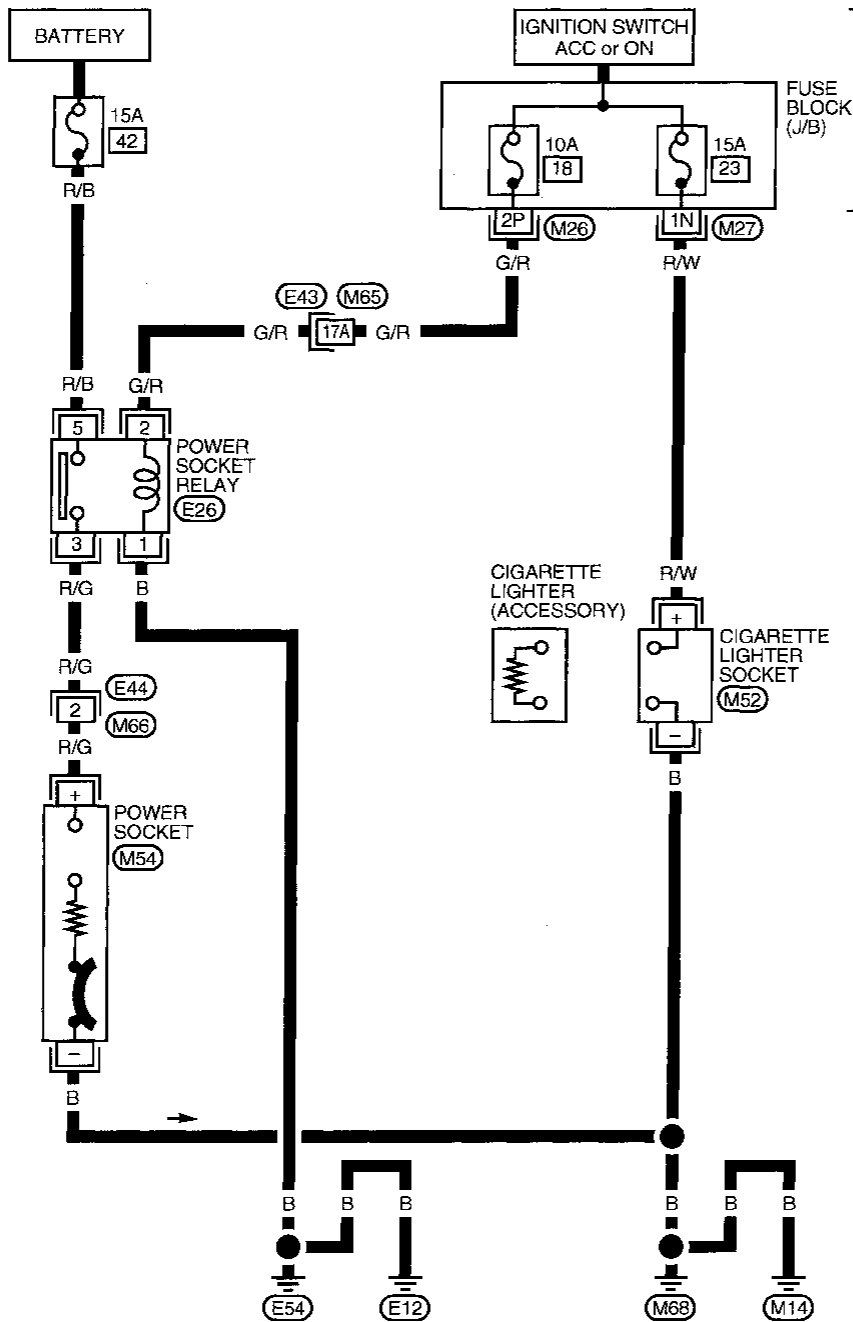

FUSE BLOCK (J/B) Refer to "EL-POWER".

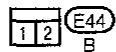
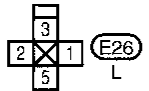
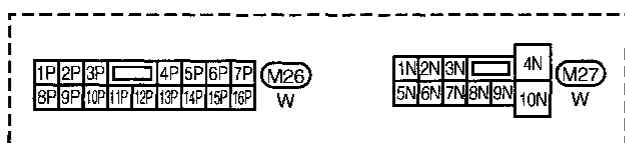

Refer to last page (Foldout page).

(M65) (E43)

GI
MA
EM
LC
EC
FE
CL
MT
AT
TF
PD
FA
RA
BR
ST
RS
BT
HA
EL
IDX

System Description

Refer to Owner's Manual for audio system operating instructions.

BASE AUDIO SYSTEM

Power is supplied at all times:

- through 15A fuse (No. 41, located in the fuse and fusible link box)
- to audio unit terminal 6.

With the ignition switch in the ACC or ON position, power is supplied:

- through 10A fuse [No. 18, located in the fuse block (J/B)]
- to audio unit terminal 10.

Ground is supplied through the case of the audio unit.

When the audio unit power knob is pushed to the ON position, audio signals are supplied:

- through audio unit terminals 1, 2, 3, 4, 13, 14, 15, and 16
- to the door speakers and tweeters.

PREMIUM AUDIO SYSTEM

Power is supplied at all times:

- through 15A fuse (No. 41, located in the fuse and fusible link box)
- to audio unit terminal 6 and
- to subwoofer amplifier terminal 8.

With the ignition switch in the ACC or ON position, power is supplied:

- through 10A fuse [No. 18, located in the fuse block (J/B)]
- to audio unit terminal 10.

Ground is supplied through the case of the audio unit.

Ground is supplied to subwoofer amplifier terminal 7 through body grounds M14 and M68.

When the system is ON, an amplifier ON signal is sent:

- through audio unit terminal 12
- to subwoofer amplifier terminal 6

and audio signals are supplied

- through audio unit terminals 1, 2, 3, 4, 13, 14, 15, and 16
- to the door speakers, tweeters, and subwoofer amplifier.

AUDIO

Wiring Diagram — AUDIO —

MODELS WITH BASE AUDIO SYSTEM

EL-AUDIO-01

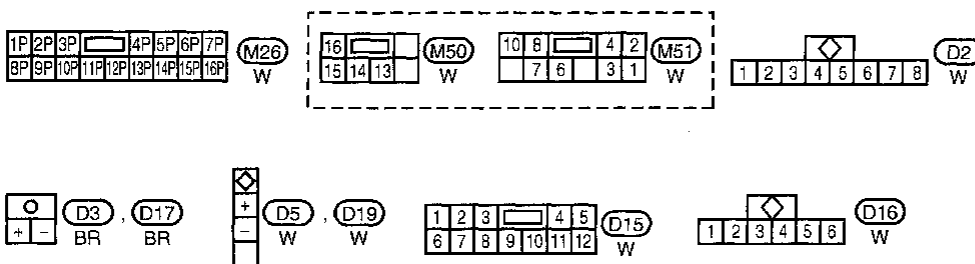
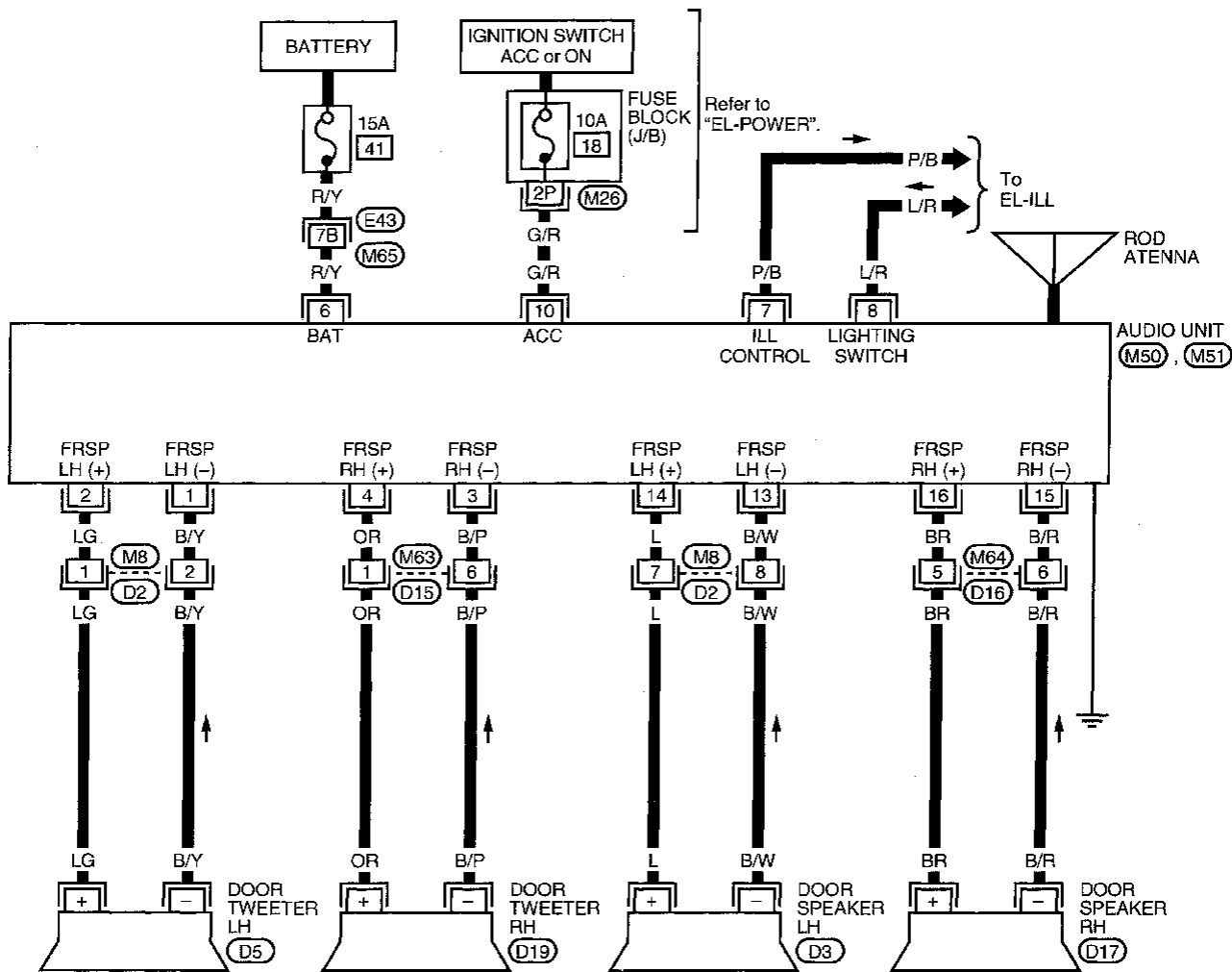

Refer to last page (Foldout page).

(M65), (E43)

AUDIO

Wiring Diagram — AUDIO — (Cont'd)

MODELS WITH PREMIUM AUDIO SYSTEM

EL-AUDIO-02

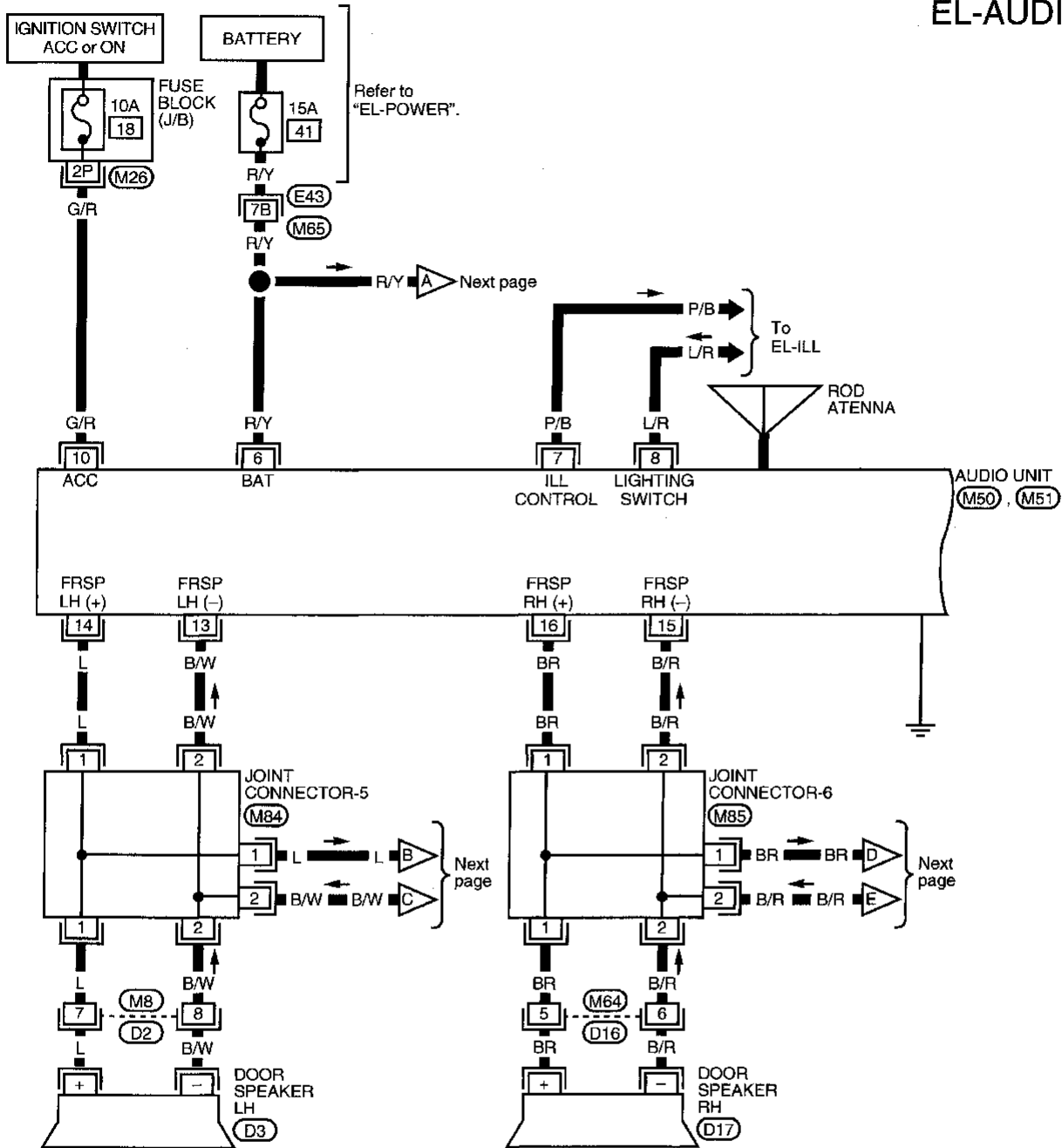

Refer to last page (Foldout page).

(M65), (E43)

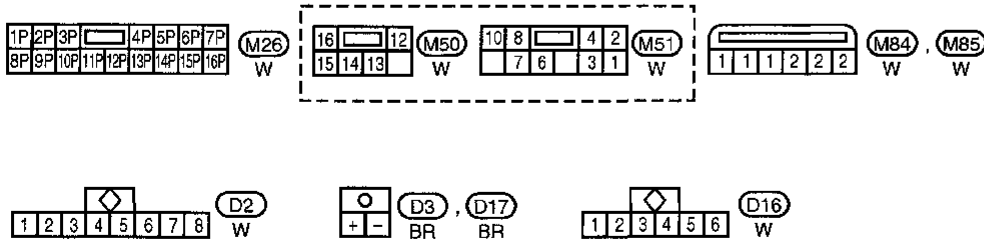

AUDIO

Wiring Diagram — AUDIO — (Cont'd)

EL-AUDIO-03

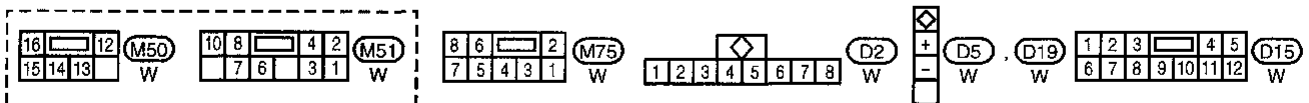
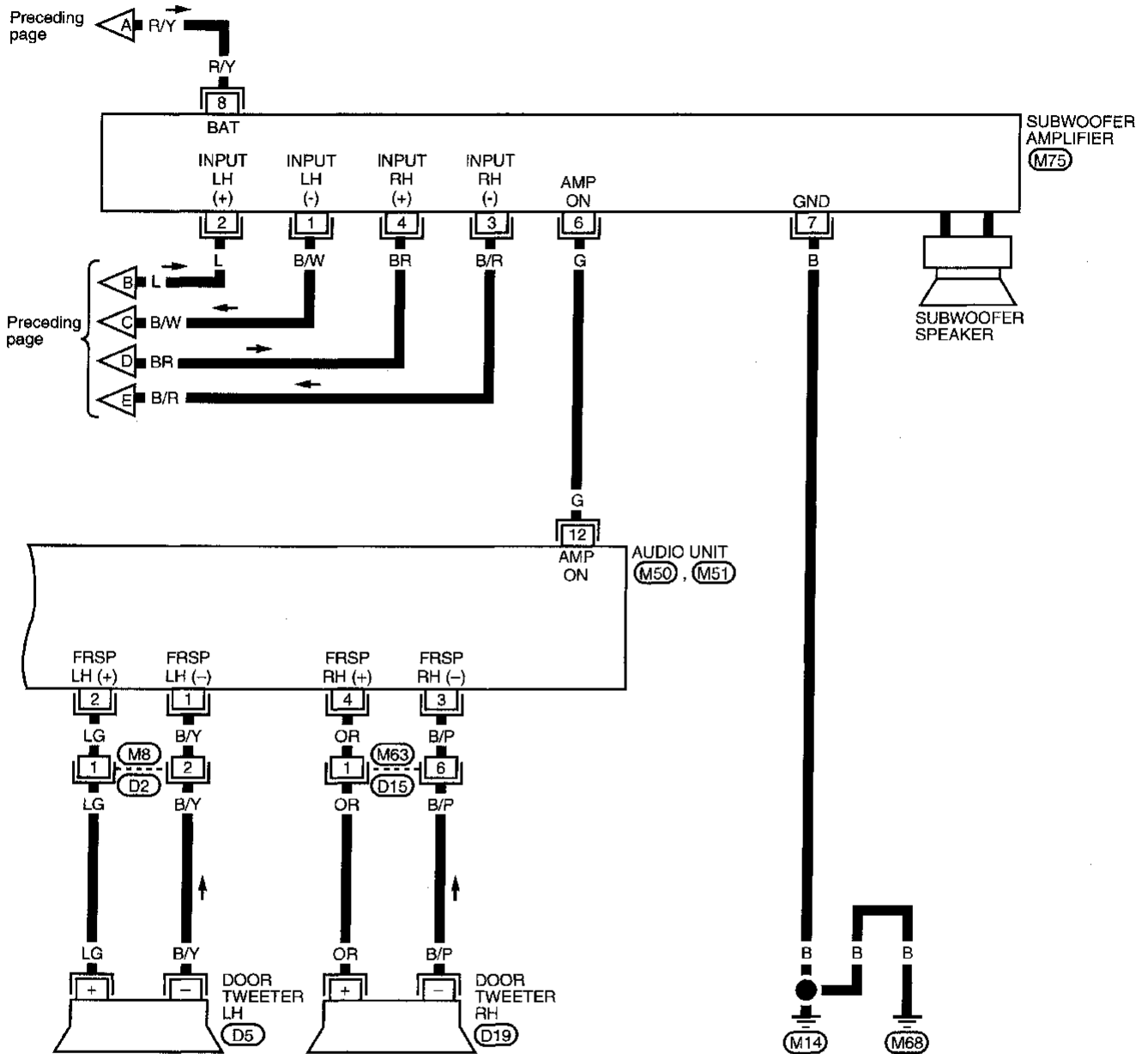

GI
 MA
 EM
 LC
 EC
 FE
 CL
 MT
 AT
 TF
 PD
 FA
 RA
 BR
 ST
 RS
 BT
 HA

EL

IDX

AUDIO

Trouble Diagnoses

AUDIO UNIT

Symptom	Possible causes	Repair order
Audio unit inoperative (no digital display and no sound from speakers).	<ol style="list-style-type: none"> 1. 10A fuse 2. Poor audio unit case ground 3. Audio unit 	<ol style="list-style-type: none"> 1. Check 10A fuse [No. 18], located in fuse block (J/B). Turn ignition switch ON and verify that battery positive voltage is present at terminal ⑩ of audio unit. 2. Check audio unit case ground. 3. Remove audio unit for repair.
Audio unit controls are operational, but no sound is heard from any speaker.	<ol style="list-style-type: none"> 1. Audio unit output 2. Audio unit 	<ol style="list-style-type: none"> 1. Check audio unit output voltages. 2. Remove audio unit for repair.
Audio unit presets are lost when ignition switch is turned OFF.	<ol style="list-style-type: none"> 1. 15A fuse 2. Audio unit 	<ol style="list-style-type: none"> 1. Check 15A fuse (No. 41), located in fuse and fusible link box) and verify that battery positive voltage is present at terminal ⑥ of audio unit. 2. Remove audio unit for repair.
Individual speaker is noisy or inoperative.	<ol style="list-style-type: none"> 1. Speaker 2. Audio unit output 3. Speaker circuit 4. Audio unit 	<ol style="list-style-type: none"> 1. Check speaker. 2. Check audio unit output voltages. 3. Check wires for open or short between audio unit and speaker. 4. Remove audio unit for repair.
Subwoofer speaker is noisy or inoperative (premium system).	<ol style="list-style-type: none"> 1. Speaker 2. Subwoofer amplifier output 3. Poor subwoofer amplifier ground 4. Audio unit "amplifier ON" signal 5. Audio unit "amplifier ON" circuit 	<ol style="list-style-type: none"> 1. Check speaker. 2. Verify that battery positive voltage is present at terminal ⑧ of subwoofer amplifier. 3. Check subwoofer amplifier ground. 4. Turn the audio unit ON and verify that approx. 10.5 volts is present at terminal ⑫ of audio unit. 5. Check wire for open or short between audio unit and subwoofer amplifier.
Audio unit stations are weak or noisy.	<ol style="list-style-type: none"> 1. Antenna 2. Poor audio unit ground 3. Audio unit 	<ol style="list-style-type: none"> 1. Check antenna. 2. Check audio unit ground. 3. Remove audio unit for repair.
Audio unit generates noise in AM and FM modes with engine running.	<ol style="list-style-type: none"> 1. Poor audio unit ground 2. Loose or missing ground bonding straps 3. Ignition condenser 4. Generator 5. Ignition coil or secondary wiring 6. Audio unit 	<ol style="list-style-type: none"> 1. Check audio unit ground. 2. Check ground bonding straps. 3. Replace ignition condenser. 4. Check generator. 5. Check ignition coil and secondary wiring. 6. Remove audio unit for repair.
Audio unit generates noise in AM and FM modes with accessories on (switch pops and motor noise).	<ol style="list-style-type: none"> 1. Poor audio unit ground 2. Antenna 3. Accessory ground 4. Faulty accessory 	<ol style="list-style-type: none"> 1. Check audio unit ground. 2. Check antenna. 3. Check accessory ground. 4. Replace accessory.

Inspection

SPEAKER

1. Disconnect speaker harness connector.
2. Measure the resistance between speaker terminals ⊕ and ⊖.
 - The resistance should be 2 - 4Ω.
3. Using jumper wires, momentarily connect a 9V battery between speaker terminals ⊕ and ⊖.
 - A momentary hum or pop should be heard.

ANTENNA

Using a jumper wire, clip an auxiliary ground between antenna and body.

- If reception improves, check antenna ground (at body surface).
- If reception does not improve, check main feeder cable for short circuit or open circuit.

AUDIO UNIT

All voltage inspections are made with:

- Ignition switch ON or ACC
- Audio unit ON
- Audio unit connected (If removed for inspection, supply a ground to the case using a jumper wire).

AUDIO VOLTAGES

Terminal	Voltage (V)	
	Base Audio System	Premium Audio System
1	5 - 7.5	5 - 7.5
2	5 - 7.5	5 - 7.5
3	5 - 7.5	5 - 7.5
4	5 - 7.5	5 - 7.5
5	—	—
6	10.8 - 15.6	10.8 - 15.6
7	—	—
8	—	—
9	—	—
10	10.8 - 15.6	10.8 - 15.6
11	—	—
12	—	Approx. 10.5
13	5 - 7.5	5 - 7.5
14	5 - 7.5	5 - 7.5
15	5 - 7.5	5 - 7.5
16	5 - 7.5	5 - 7.5

SUBWOOFER AMPLIFIER VOLTAGES

Terminal	Voltage (V)
1	5 - 7.5
2	5 - 7.5
3	5 - 7.5
4	5 - 7.5
5	—
6	Approx. 10.5
7	Body ground
8	10.8 - 15.6

GI
 MA
 EM
 LC
 EC
 FE
 CL
 MT
 AT
 TF
 PD
 FA
 RA
 BR
 ST
 RS
 BT
 HA
 EL
 IDX

AUDIO ANTENNA

Fixed Antenna Rod Replacement

REMOVAL

1. Remove antenna rod.
2. Remove rubber seal.
3. Remove cowl top seal.
4. Remove right wiper arm.
5. Remove right cowl top grille.
6. Remove antenna base bolts.
7. Remove right fender splash shield.
8. Remove audio unit.
9. Disconnect antenna cable from audio unit.
10. Remove attachment clip from fender apron.
11. Remove antenna base and cable.

INSTALLATION

Install in reverse order of removal.

CAUTION:

Always properly tighten the antenna rod during installation or the antenna rod may bend or break during vehicle operation.

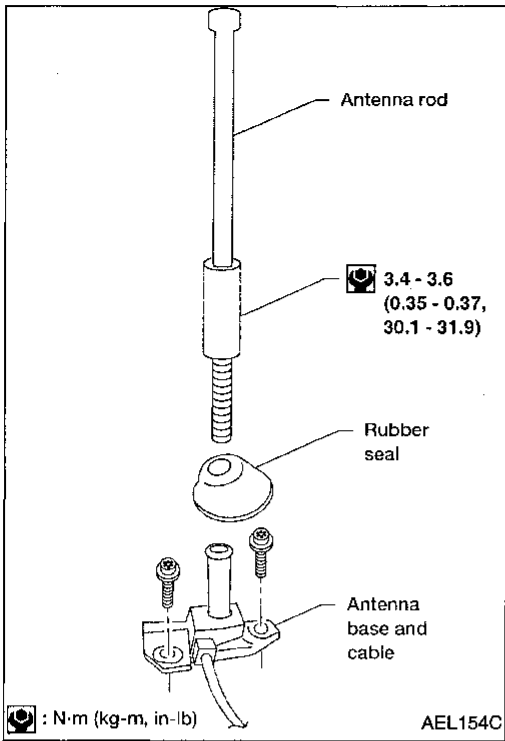

POWER DOOR MIRROR

Wiring Diagram — MIRROR —

EL-MIRROR-01

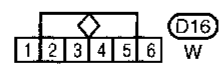
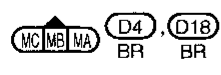
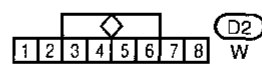
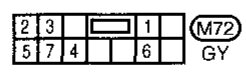
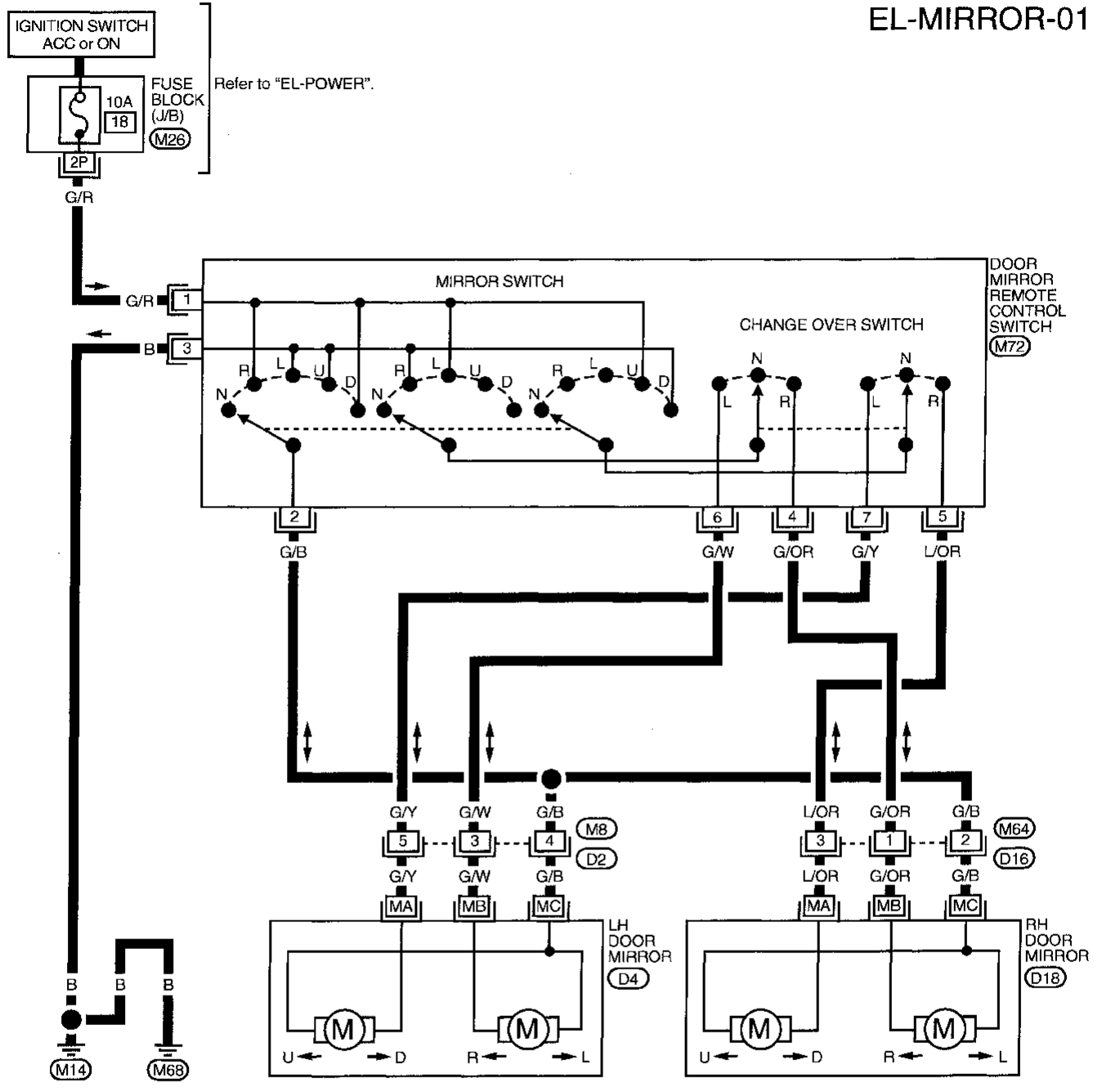

GI
MA
EM
LC
EC
FE
CL
MT
AT
TF
PD
FA
RA
BR
ST
RS
BT
HA
EL
IDX

AUTOMATIC SPEED CONTROL DEVICE (ASCD)

Component Parts and Harness Connector Location

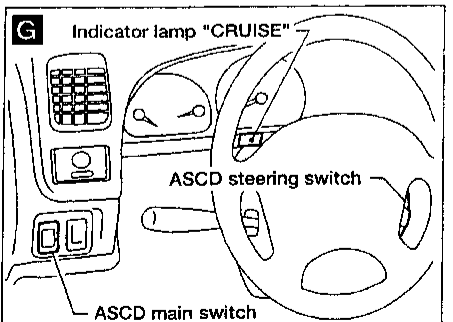
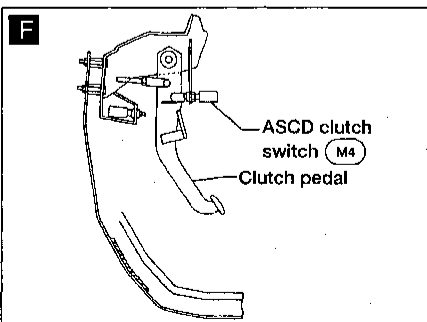
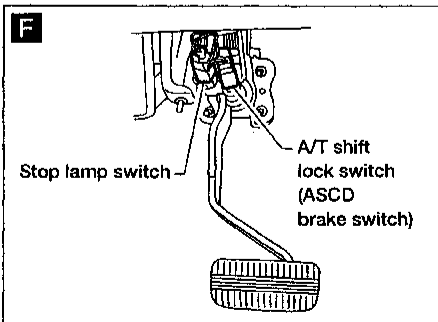
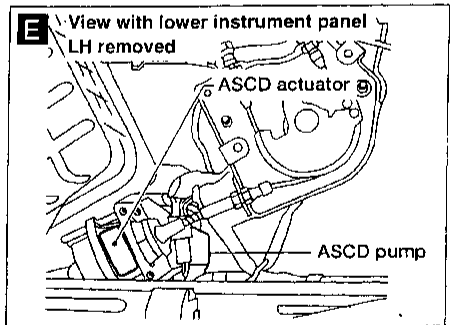
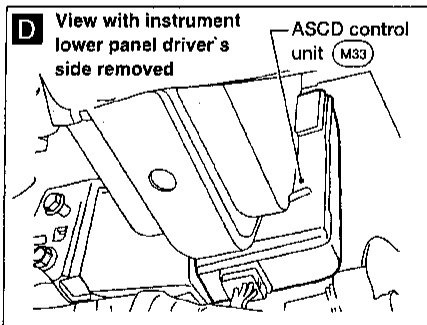
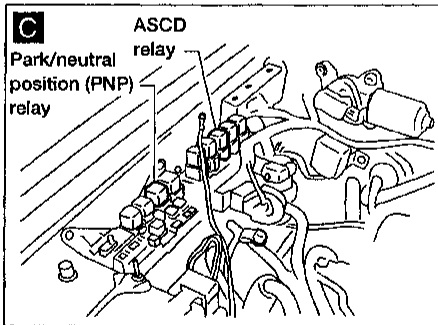
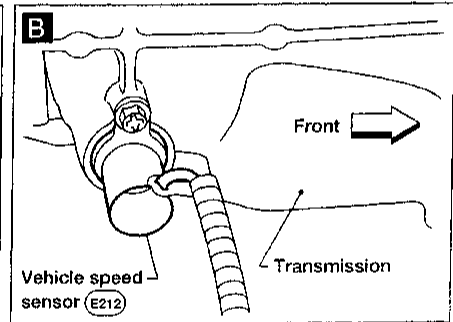
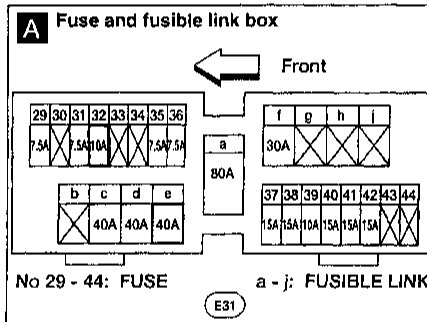
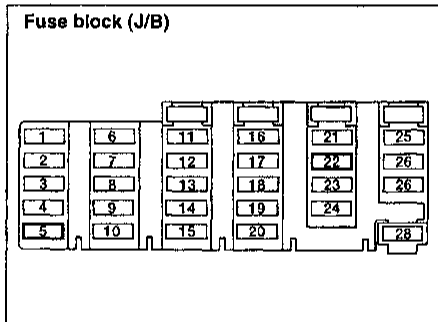
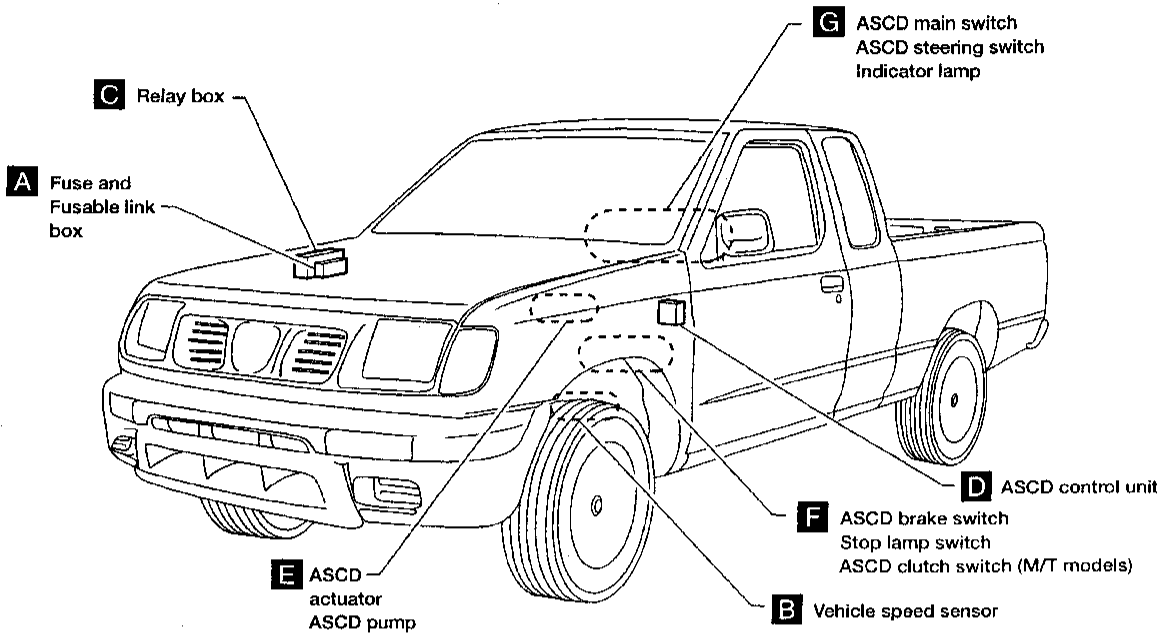

AUTOMATIC SPEED CONTROL DEVICE (ASCD)

System Description

Refer to Owner's Manual for ASCD operating instructions.

When the ignition switch is in the ON or START position, power is supplied:

- through 7.5A fuse [No. 5], located in the fuse block (J/B)
- to ASCD main switch terminal ①
- to ASCD hold relay terminal ⑤
- to ASCD brake switch terminal ①
- through ASCD brake switch terminal ②
- to ASCD hold relay terminal ⑦.

When ASCD main switch is in the ON position, power is supplied:

- from ASCD main switch terminal ③
- to ASCD hold relay terminal ②.

Ground is supplied:

- to ASCD hold relay terminal ①
- through body grounds M14 and M68.

With power and ground supplied, ASCD hold relay is energized, and then power is supplied:

- from ASCD hold relay terminal ③
- to ASCD control unit terminal ④ and
- to ASCD main switch terminal ②.

After the ASCD main switch is released, power remains supplied:

- to the coil circuit of ASCD hold relay
- through ASCD main switch terminal ③.

This power supply is kept until one of following conditions exists.

- Ignition switch is returned to the ACC or OFF position.
- ASCD main switch is pushed to OFF position.

When ASCD hold relay is energized, power is also supplied to ASCD control unit terminal ⑤

- through ASCD brake switch and
- ASCD clutch switch (with M/T) or
- ASCD relay (with A/T).

Ground is supplied:

- to ASCD control unit terminal ③
- through body grounds M14 and M68.

INPUTS

At this point, the system is ready to activate or deactivate, based on inputs from the following:

- speedometer in the combination meter
- stop lamp switch
- ASCD steering switch
- ASCD clutch switch (with M/T) or
- ASCD relay (with A/T)
- ASCD brake switch.

A vehicle speed input is supplied:

- to ASCD control unit terminal ⑦
- from terminal ⑳ of the combination meter.

Power is supplied at all times:

- to stop lamp switch terminal ①
- through 10A fuse [No. 22], located in the fuse block (J/B)].

When the brake pedal is depressed, power is supplied:

- from terminal ② of the stop lamp switch
- to ASCD control unit terminal ⑩.

Power is supplied at all times:

- through 10A fuse [No. 32], located in the fuse and fusible link box]
- to horn relay terminal ②
- through terminal ① of the horn relay
- to ASCD steering switch terminal ③.

When the SET/COAST switch is depressed, power is supplied:

- from terminal ② of the ASCD steering switch
- to ASCD control unit terminal ②.

GI

MA

EM

LC

EC

FE

CL

MT

AT

TF

PD

FA

RA

BR

ST

RS

BT

HA

EL

IDX

AUTOMATIC SPEED CONTROL DEVICE (ASCD)

System Description (Cont'd)

When the RESUME/ACCEL switch is depressed, power is supplied:

- from terminal ① of the ASCD steering switch
- to ASCD control unit terminal ①.

When the ASCD CANCEL switch is depressed, power is supplied:

- to ASCD control unit terminals ① and ②.

When the system is activated, power is supplied:

- from ASCD clutch switch terminal ② (with M/T) or
- from ASCD relay terminal ④ (with A/T)
- to ASCD control unit terminal ⑤.

Power is interrupted when:

- the ASCD main switch is turned to OFF
- the ASCD clutch switch is depressed (with M/T),
- the A/T selector lever is placed in P or N (with A/T) or
- the ASCD brake switch is depressed.

OUTPUTS

The ASCD actuator controls the throttle drum via the ASCD wire based on inputs from the ASCD control unit. The ASCD pump consists of a vacuum motor, an air valve, and a release valve.

Power is supplied:

- from terminal ⑧ of the ASCD control unit
- to ASCD pump terminal ①.

Ground is supplied to the vacuum motor:

- from terminal ⑨ of the ASCD control unit
- to ASCD pump terminal ②.

Ground is supplied to the air valve:

- from terminal ⑩ of the ASCD control unit
- to ASCD pump terminal ③.

Ground is supplied to the release valve:

- from terminal ⑭ of the ASCD control unit
- to ASCD pump terminal ④.

When the system is activated, power is supplied:

- from terminal ⑬ of the ASCD control unit
- to combination meter terminal ⑳.

Ground is supplied:

- to combination meter terminal ⑳
- through body grounds M14 and M68.

With power and ground supplied, the CRUISE indicator illuminates.

When vehicle speed is approximately 8 km/h (5 MPH) below set speed on A/T models, ground is supplied:

- to terminal ② of the solenoid valve unit
- from ASCD control unit terminal ⑫.

When this occurs, the overdrive is canceled.

When vehicle speed reaches approximately 3 km/h (2 MPH) above set speed, overdrive is reactivated.

AUTOMATIC SPEED CONTROL DEVICE (ASCD)

Schematic

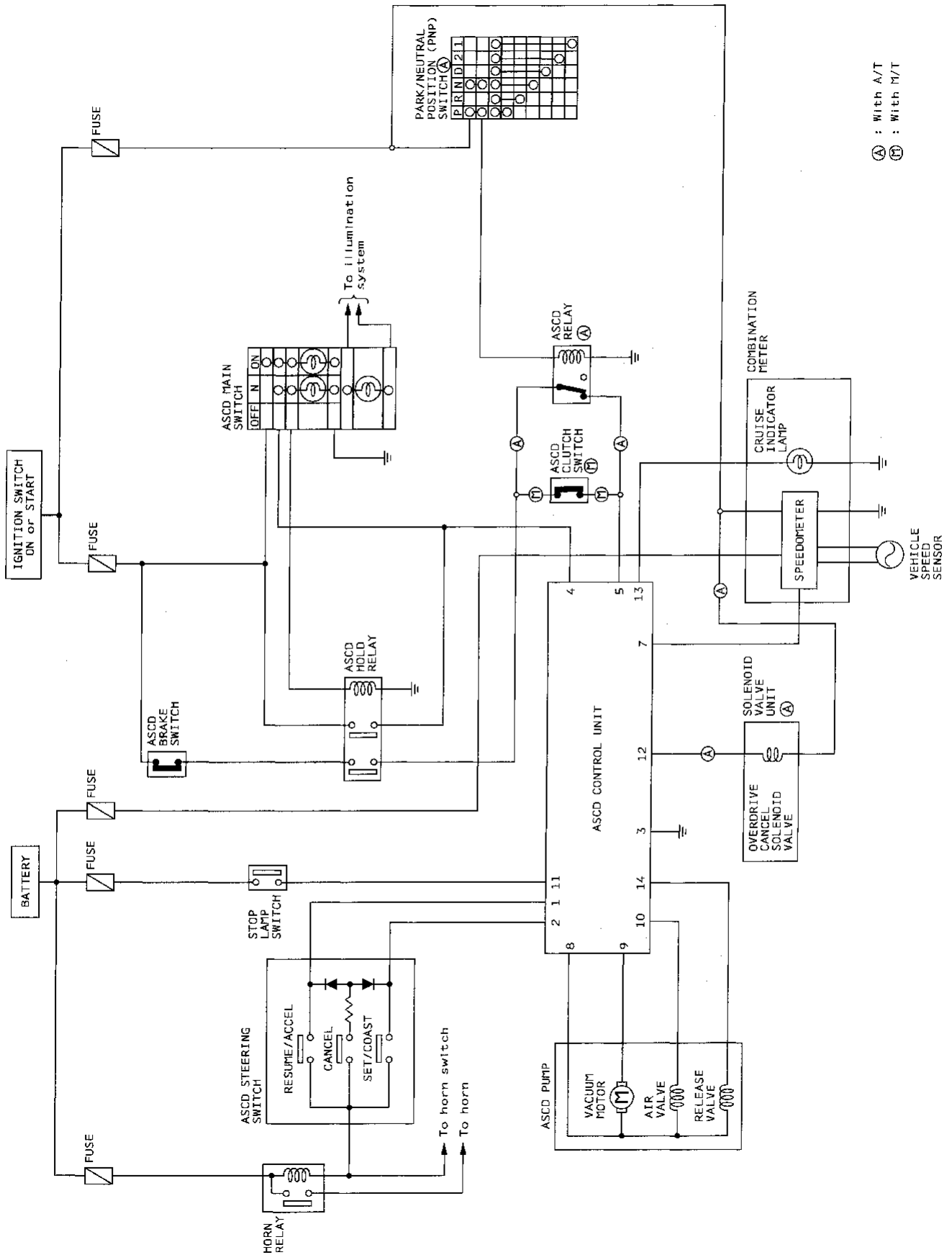

GI
 MA
 EM
 LC
 EC
 FE
 CL
 MT
 AT
 TF
 PD
 FA
 RA
 BR
 ST
 RS
 BT
 HA
EL
 IDX

AUTOMATIC SPEED CONTROL DEVICE (ASCD)

Wiring Diagram — ASCD —

EL-ASCD-01

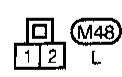
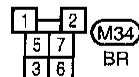
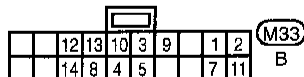
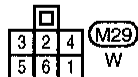
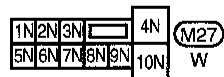
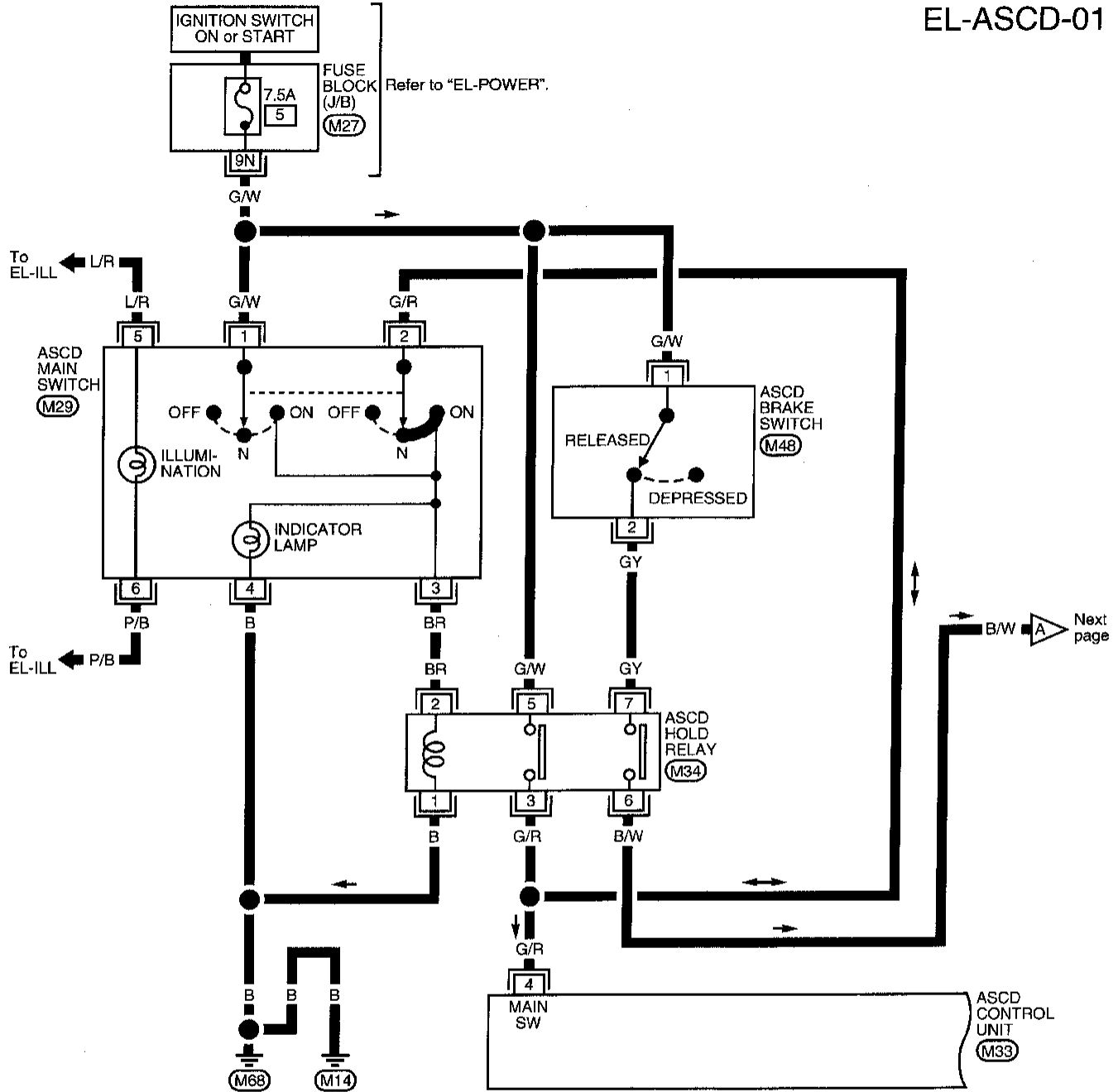

AUTOMATIC SPEED CONTROL DEVICE (ASCD)

Wiring Diagram — ASCD — (Cont'd)

EL-ASCD-02

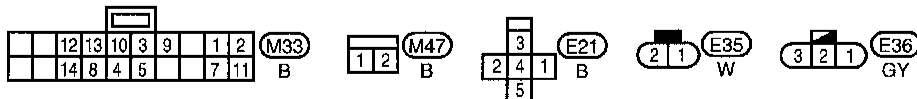
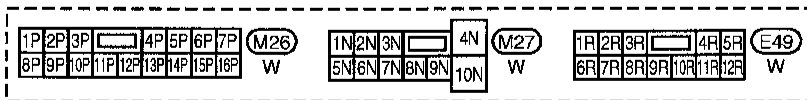
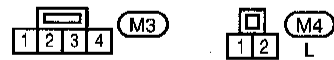
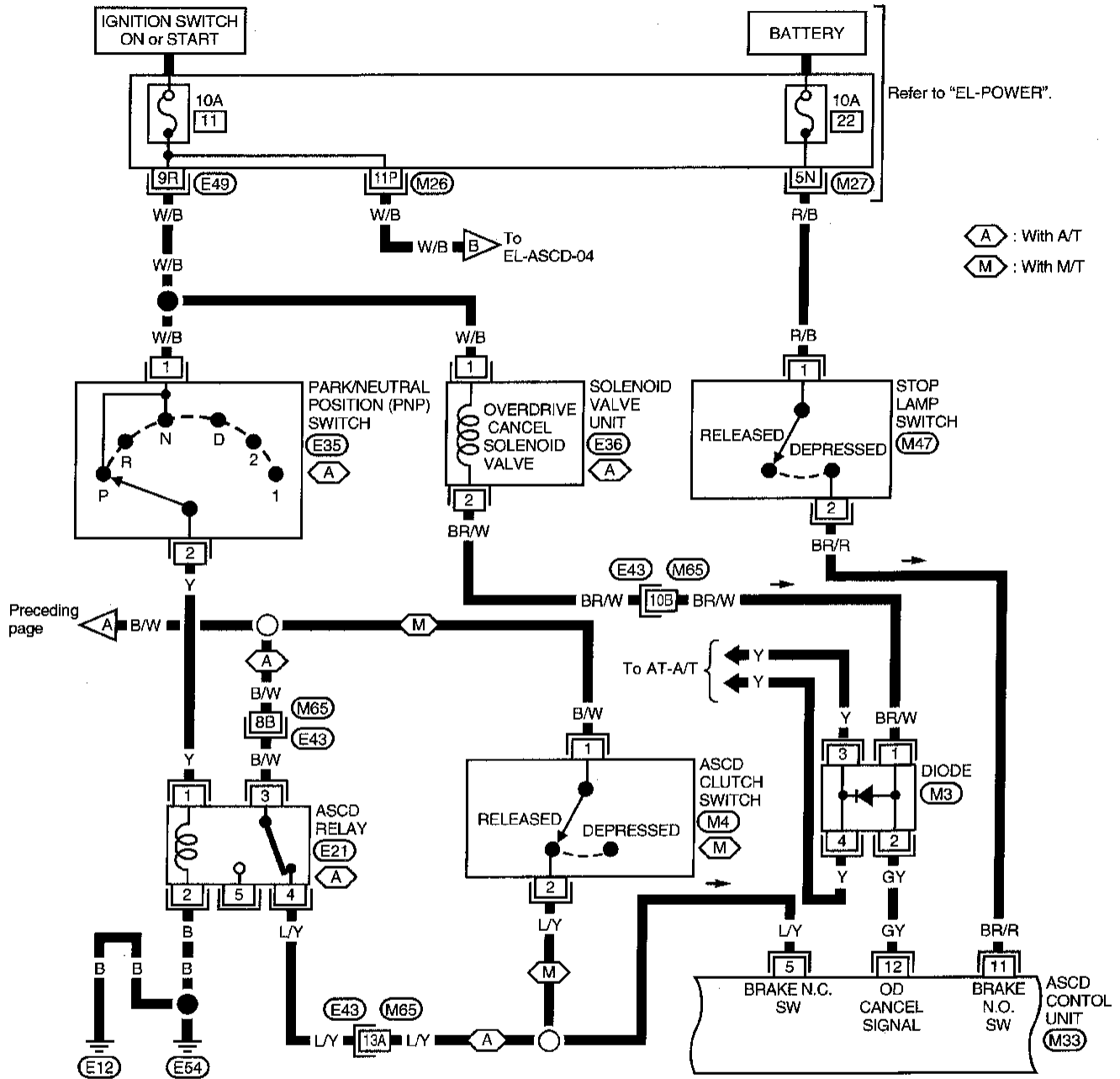

Refer to last page (Foldout page).

(M65) (E43)

AUTOMATIC SPEED CONTROL DEVICE (ASCD)

Wiring Diagram — ASCD — (Cont'd)

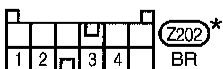
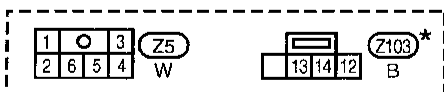
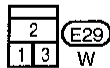
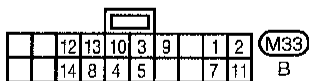
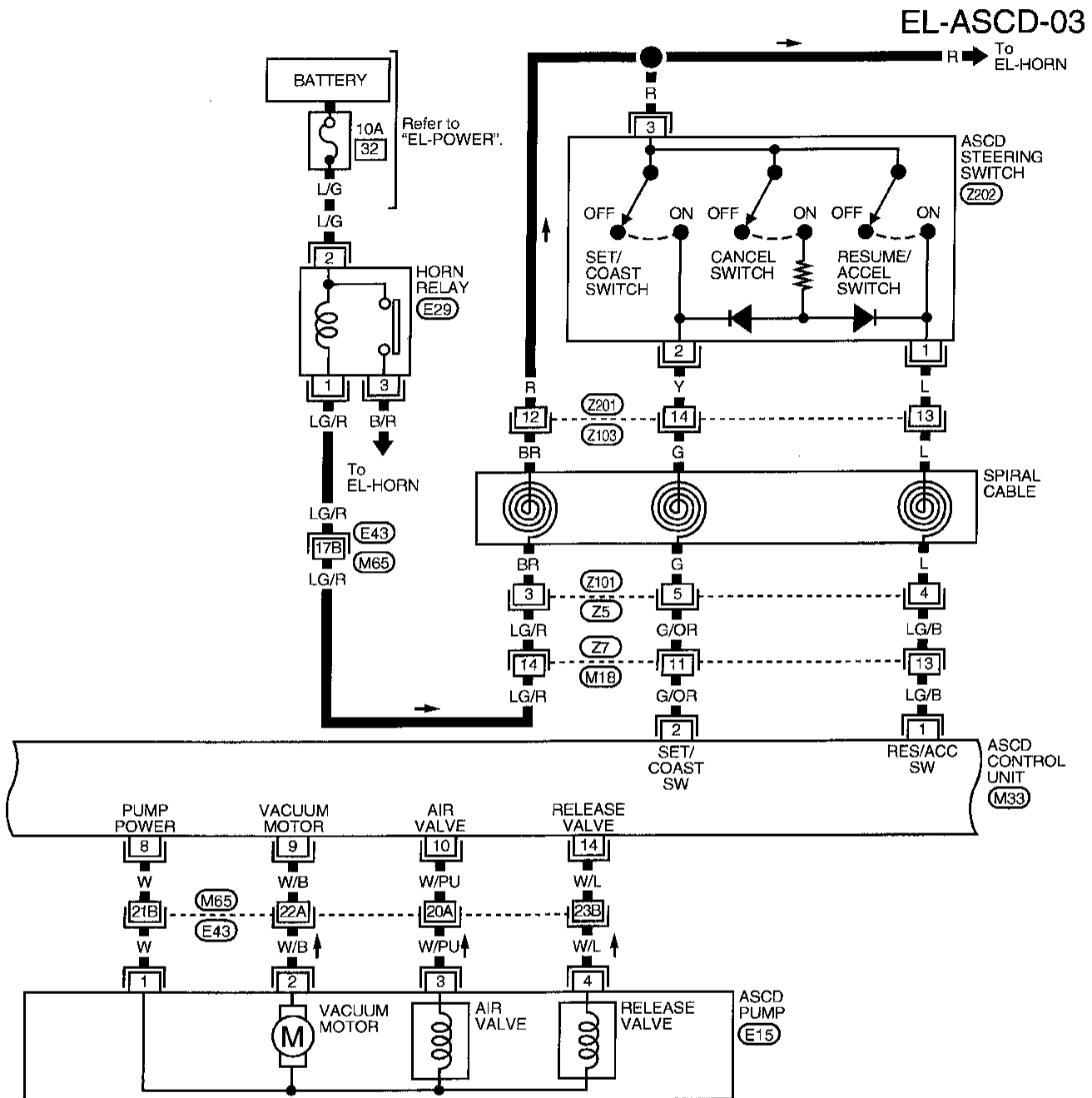

Refer to last page (Foldout page).
(M65) (E43)

* : This connector is not shown in "HARNESS LAYOUT" of EL section.

AUTOMATIC SPEED CONTROL DEVICE (ASCD)

Wiring Diagram — ASCD — (Cont'd)

EL-ASCD-04

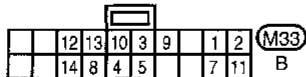
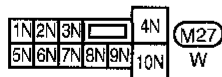
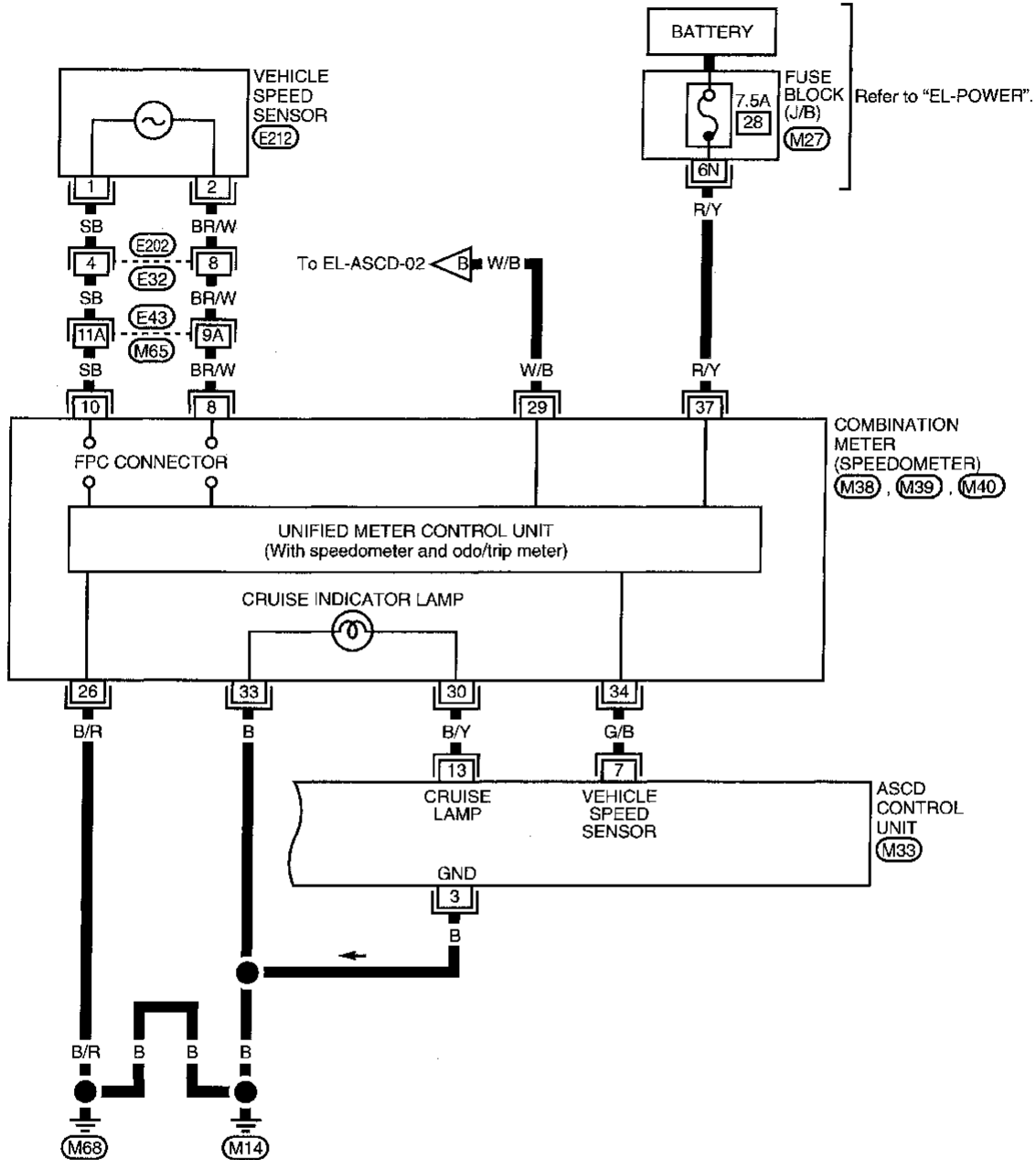

Refer to last page (Foldout page).
(M65, E43)

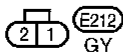
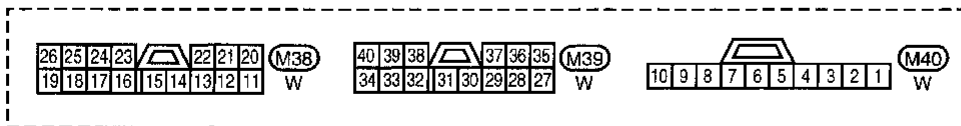

GI
 MA
 EM
 LC
 EC
 FE
 CL
 MT
 AT
 TF
 PD
 FA
 RA
 BR
 ST
 RS
 BT
 HA
 EL
 IDX

AUTOMATIC SPEED CONTROL DEVICE (ASCD)

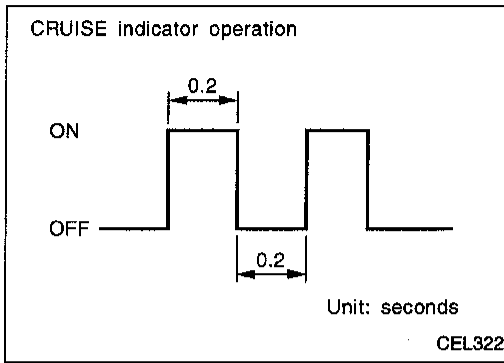

Fail-Safe System Description

When the fail-safe system senses a malfunction, it deactivates ASCD operation. The CRUISE indicator in the combination meter will then flash.

MALFUNCTION DETECTION CONDITIONS

Detection conditions	ASCD operation during malfunction detection
<ul style="list-style-type: none"> ● ASCD steering (RESUME/ACCEL, CANCEL, SET/COAST) switch is stuck. ● Vacuum motor ground circuit or power circuit is open or shorted. ● Air valve ground circuit or power circuit is open or shorted. ● Release valve ground circuit or power circuit is open or shorted. ● Vehicle speed sensor is faulty. ● ASCD control unit internal circuit is malfunctioning. 	<ul style="list-style-type: none"> ● ASCD is deactivated. ● Vehicle speed memory is canceled.
<ul style="list-style-type: none"> ● ASCD brake switch or stop lamp switch is faulty. 	<ul style="list-style-type: none"> ● ASCD is deactivated. ● Vehicle speed memory is not canceled.

AUTOMATIC SPEED CONTROL DEVICE (ASCD)

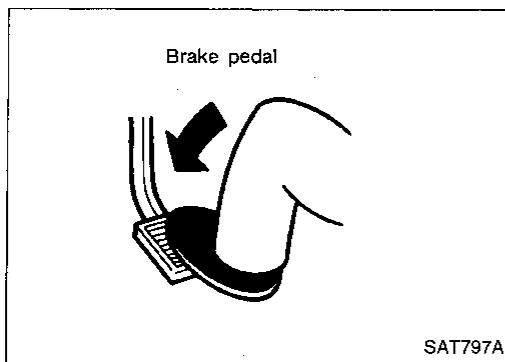
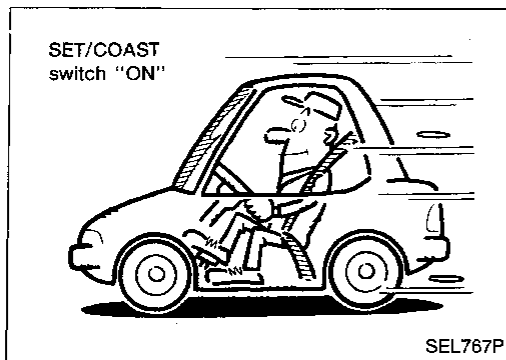
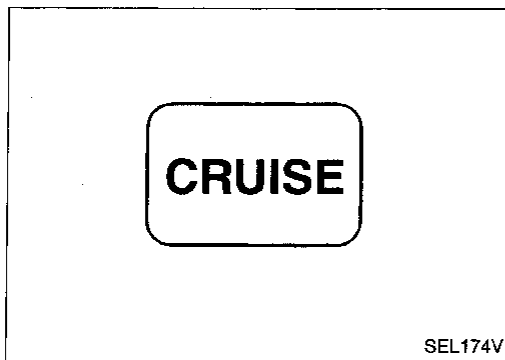

Fail-Safe System Check

1. Turn ignition switch ON.
2. Turn ASCD main switch to ON position and check if the "cruise indicator" blinks.

If the indicator lamp blinks, check the following.

- ASCD steering switch. Refer to "DIAGNOSTIC PROCEDURE 5" (EL-146).

3. Drive the vehicle at more than 48 km/h (30 MPH) and push SET/COAST switch.

If the indicator lamp blinks, check the following:

- Vehicle speed sensor. Refer to "DIAGNOSTIC PROCEDURE 6" (EL-147).
- ASCD pump circuit. Refer to "DIAGNOSTIC PROCEDURE 7" (EL-148).
- Replace control unit.

4. Depress brake pedal slowly (brake pedal should be depressed more than 5 seconds).

If the indicator lamp blinks, check the following:

- ASCD brake/stop lamp switch. Refer to "DIAGNOSTIC PROCEDURE 4" (EL-145).

5. END. (System is OK.)

GI

MA

EM

LC

EC

FE

CL

MT

AT

TF

PD

FA

RA

BR

ST

RS

BT

HA

EL

IDX

AUTOMATIC SPEED CONTROL DEVICE (ASCD)

Trouble Diagnoses

SYMPTOM CHART

PROCEDURE	Diagnostic procedure								
REFERENCE PAGE	EL-141	EL-143	EL-143	EL-144	EL-145	EL-146	EL-147	EL-148	EL-149
SYMPTOM	Fail-safe system check	DIAGNOSTIC PROCEDURE 1 (POWER SUPPLY AND GROUND CIRCUIT CHECK)	DIAGNOSTIC PROCEDURE 2 (ASCD MAIN SWITCH CHECK)	DIAGNOSTIC PROCEDURE 3 (ASCD HOLD RELAY CHECK)	DIAGNOSTIC PROCEDURE 4 (ASCD BRAKE/STOP LAMP SWITCH CHECK)	DIAGNOSTIC PROCEDURE 5 (ASCD STEERING SWITCH CHECK)	DIAGNOSTIC PROCEDURE 6 (VEHICLE SPEED SENSOR CHECK)	DIAGNOSTIC PROCEDURE 7 (ASCD PUMP CIRCUIT CHECK)	DIAGNOSTIC PROCEDURE 8 (ASCD ACTUATOR/PUMP CHECK)
ASCD cannot be set. ("CRUISE" indicator lamp does not blink.)		X	X	X		X	X		
ASCD cannot be set. ("CRUISE" indicator lamp blinks.★1)	X				X	X	X	X	
Vehicle speed does not decrease after SET/COAST switch has been pressed.						X			X
Vehicle speed does not return to the set speed after RESUME/ACCEL switch has been pressed.★2						X			X
Vehicle speed does not increase after RESUME/ACCEL switch has been pressed.						X			X
System is not released after CANCEL switch (steering) has been pressed.						X			X
Large difference between set speed and actual vehicle speed.									X
Deceleration is greatest immediately after ASCD has been set.									X

X: Applicable

★1: It indicates that system is in fail-safe. After completing diagnostic procedures, perform "Fail-Safe System Check" (EL-141) to verify repairs.

★2: If vehicle speed is greater than 48 km/h (30 MPH) after system has been released, pressing RESUME/ACCEL switch returns vehicle speed to the set speed previously achieved. However, doing so when the ASCD main switch is turned to "OFF", vehicle speed will not return to the set speed since the memory is canceled.

AUTOMATIC SPEED CONTROL DEVICE (ASCD)

Trouble Diagnoses (Cont'd)

DIAGNOSTIC PROCEDURE 1

(POWER SUPPLY AND GROUND CIRCUIT CHECK)

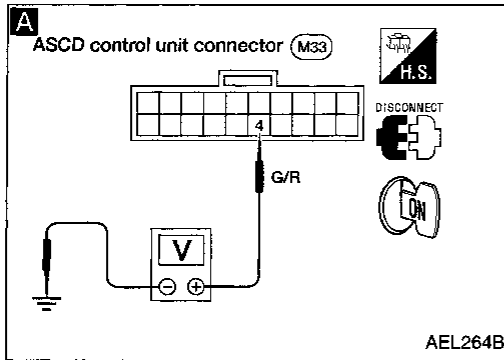

1. Turn ignition switch ON.
2. Turn ASCD main switch ON to make sure indicators illuminate.

NG → Go to DIAGNOSTIC PROCEDURE 2 (ASCD MAIN SWITCH CHECK).
OK ↓

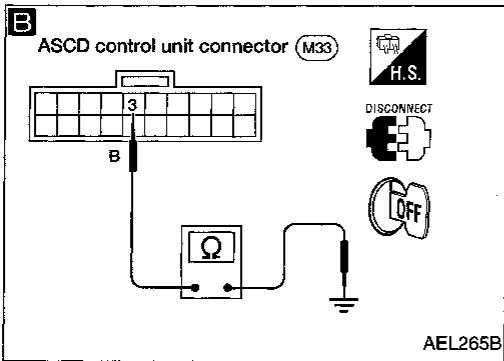

A
CHECK POWER SUPPLY CIRCUIT FOR ASCD CONTROL UNIT.
1. Disconnect ASCD control unit connector.
2. Turn ignition switch ON.
3. Turn ASCD main switch ON.
4. Check voltage between control unit connector terminal ④ and ground.
Battery voltage should exist.
Refer to wiring diagram in EL-136.

NG → Go to DIAGNOSTIC PROCEDURE 3 (ASCD HOLD RELAY CHECK). Refer to EL-144.
OK ↓

B
CHECK GROUND CIRCUIT FOR ASCD CONTROL UNIT.
Check continuity between ASCD control unit harness terminal ③ and body ground.
Refer to wiring diagram in EL-139.

NG → Repair harness.
OK ↓

Power supply and ground circuit is ok.

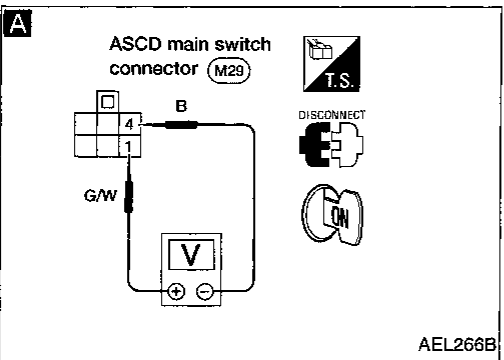

DIAGNOSTIC PROCEDURE 2 (ASCD MAIN SWITCH CHECK)

A
CHECK POWER SUPPLY FOR ASCD MAIN SWITCH.
1. Disconnect ASCD main switch connector.
2. Measure voltage between main switch terminals ① and ④.
Battery voltage should exist.
Refer to wiring diagram in EL-136.

NG → Check the following.
● 7.5A fuse [No. ⑤], located in the fuse block (J/B)]
● Harness for open or short between fuse and ASCD main switch
● Ground circuit for ASCD main switch
OK ↓

CHECK ASCD MAIN SWITCH.
Refer to "Electrical Components Inspection", EL-151.

NG → Replace ASCD main switch.
OK ↓

Go to DIAGNOSTIC PROCEDURE 3 (ASCD HOLD RELAY CHECK), Refer to EL-144.

AUTOMATIC SPEED CONTROL DEVICE (ASCD)

Trouble Diagnoses (Cont'd)

DIAGNOSTIC PROCEDURE 3 (ASCD HOLD RELAY CHECK)

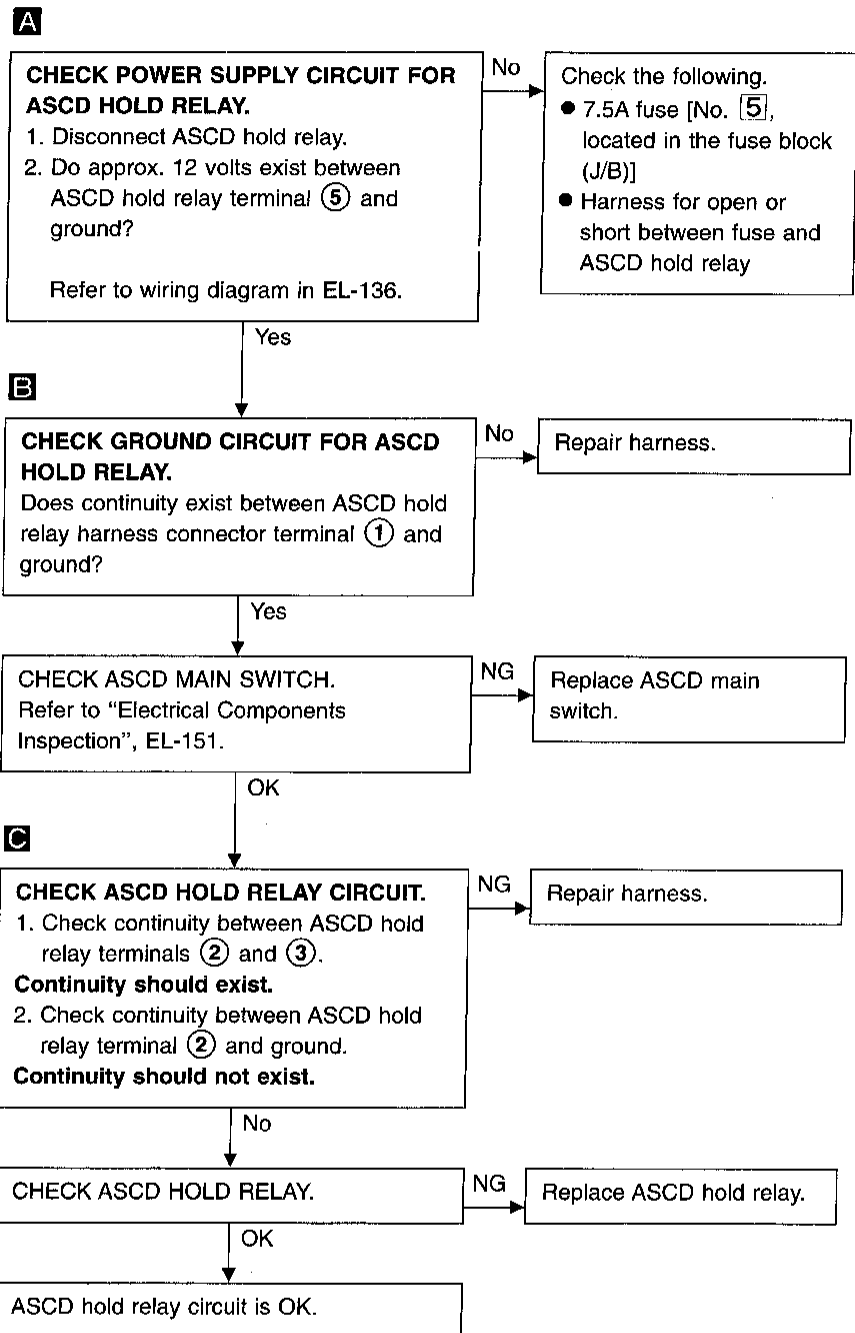
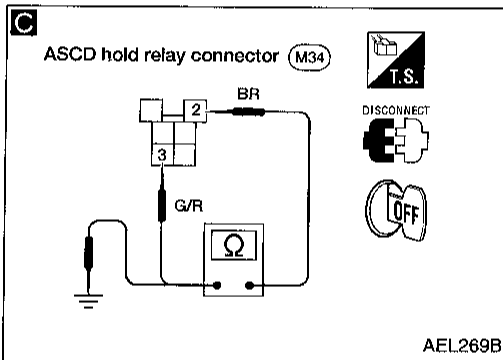
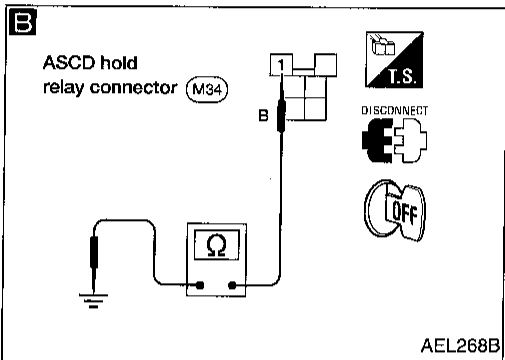
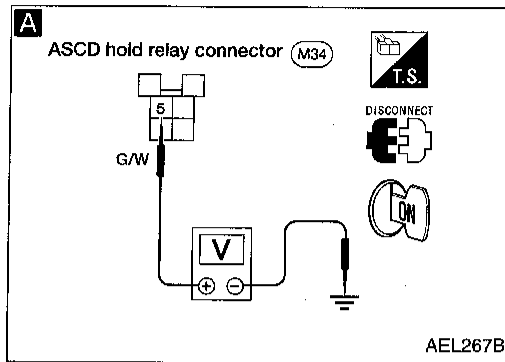

AUTOMATIC SPEED CONTROL DEVICE (ASCD)

Trouble Diagnoses (Cont'd)

DIAGNOSTIC PROCEDURE 4

(ASCD BRAKE/STOP LAMP SWITCH CHECK)

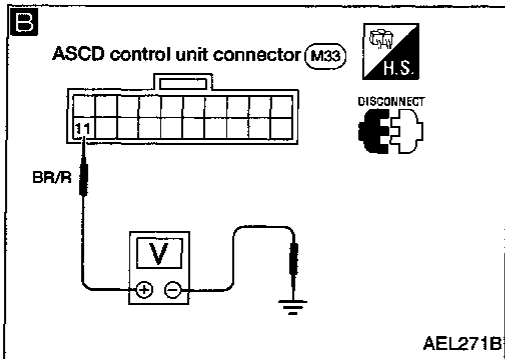
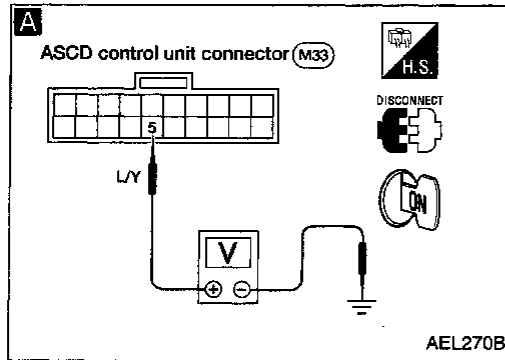

A

CHECK ASCD BRAKE SWITCH CIRCUIT.

1. Disconnect control unit connector.
2. Turn ignition switch ON.
3. Turn ASCD main switch ON.
4. Check voltage between control unit connector terminal (5) and ground. When brake pedal or clutch pedal (M/T) is depressed or A/T selector lever (A/T) is in N or P range:
Approx. 0V
When brake pedal and clutch pedal (M/T) are released or A/T selector lever (A/T) is not in N or P range:
Battery voltage should exist.

Refer to wiring diagram in EL-137.

NG

Check the following.

- ASCD brake switch
Refer to "Electrical Components Inspection", EL-151.
- ASCD clutch switch (with M/T)
Refer to "Electrical Components Inspection", EL-151.
- Park/neutral position (PNP) switch (with A/T)
Refer to "Electrical Components Inspection", EL-151.
- ASCD hold relay
- Harness for open or short

B

CHECK STOP LAMP SWITCH CIRCUIT.

1. Disconnect control unit connector.
2. Check voltage between control unit terminal (11) and ground.

Condition		Voltage [V]
Stop lamp switch	Depressed	Approx. 12
	Released	0

Refer to wiring diagram in EL-137.

NG

Check the following.

- 10A fuse [No. 22, located in the fuse block (J/B)]
- Harness for open or short between ASCD control unit and stop lamp switch
- Stop lamp switch
Refer to "Electrical Components Inspection", EL-151.

OK

ASCD brake/stop lamp switch circuit switch is OK.

GI
MA
EM
LC
EC
FE
CL
MT
AT
TF
PD
FA
RA
BR
ST
RS
BT
HA
EL
IDX

AUTOMATIC SPEED CONTROL DEVICE (ASCD)

Trouble Diagnoses (Cont'd)

DIAGNOSTIC PROCEDURE 5

(ASCD STEERING SWITCH CHECK)

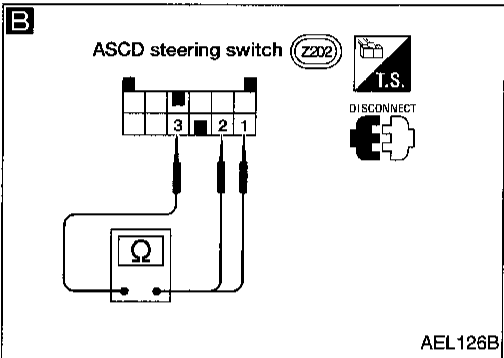
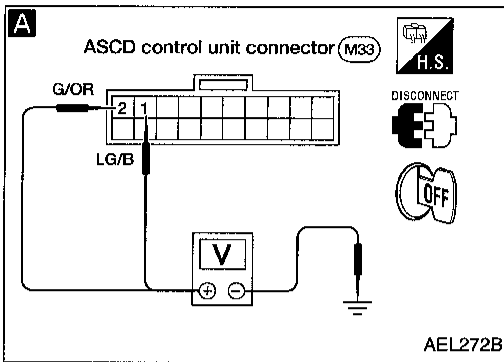

A

CHECK ASCD STEERING SWITCH CIRCUIT FOR ASCD CONTROL UNIT.

1. Disconnect control unit connector.
2. Check voltage between control unit harness terminals and ground.

	Terminal No.		Switch condition	
	⊕	⊖	Pressed	Released
SET/COAST SW	②	Ground	12V	0V
RESUME/ACC SW	①	Ground	12V	0V
CANCEL SW	②	Ground	12V	0V
	①	Ground	12V	0V

Refer to wiring diagram in EL-138.

OK → ASCD steering switch is OK.

NG

CHECK POWER SUPPLY FOR ASCD STEERING SWITCH.

Does horn work?

- NG → Check the following.
- 10A fuse (No. 32, located in the fuse and fusible link box)
 - Horn relay
 - Harness for open or short between horn and fuse

B

CHECK ASCD STEERING SWITCH.

1. Disconnect ASCD steering switch.
2. Check continuity between terminals by pushing each switch.

Switch	Terminal		
	③	②	①
RESUME/ACCEL	○	—	○
SET/COAST	○	○	
CANCEL	○	▶	○
	○	▶	○

NG → Replace ASCD steering switch.

OK

Check harness for open or short between ASCD steering switch and ASCD control unit.

AUTOMATIC SPEED CONTROL DEVICE (ASCD)

Trouble Diagnoses (Cont'd)

DIAGNOSTIC PROCEDURE 6

(VEHICLE SPEED SENSOR CHECK)

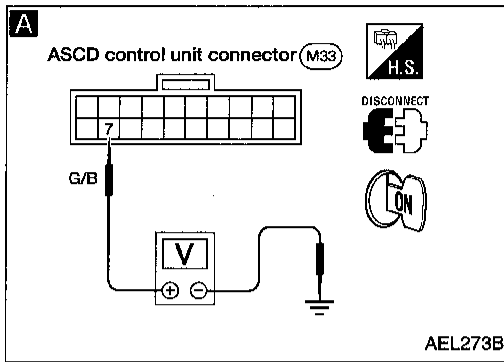

A

CHECK VEHICLE SPEED SENSOR CIRCUIT.

1. Apply wheel chocks and jack up drive wheel.
2. Disconnect control unit connector.
3. Connect voltmeter between control unit terminal ⑦ and ground.
4. Slowly turn drive wheel.
5. Check deflection of voltmeter pointer.

Refer to wiring diagram in EL-139.

OK → Vehicle speed sensor is OK.

NG

Does speedometer operate normally?

No

Check speedometer and vehicle speed sensor circuit. Refer to EL-85.

Yes

Check harness for open or short between ASCD control unit terminal ⑦ and combination meter terminal ③④.

GI

MA

EM

LC

EC

FE

CL

MT

AT

TF

PD

FA

RA

BR

ST

RS

BT

HA

EL

IDX

AUTOMATIC SPEED CONTROL DEVICE (ASCD)

Trouble Diagnoses (Cont'd)

DIAGNOSTIC PROCEDURE 7

(ASCD PUMP CIRCUIT CHECK)

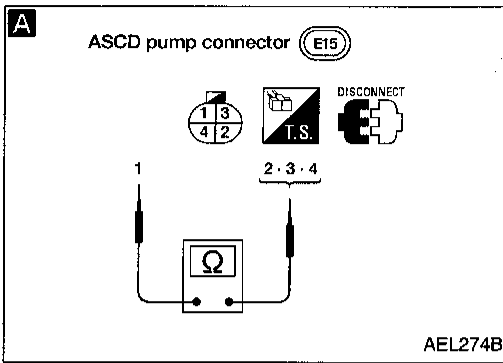

A

CHECK ASCD PUMP.

1. Disconnect ASCD pump connector.
2. Measure resistance between ASCD pump terminals ① and ②, ③, ④.

Terminals	Resistance [Ω]	
①	②	Approx. 18.2
	③	Approx. 65.5
	④	Approx. 65.5

Refer to wiring diagram in EL-138.

NG → Replace ASCD pump.

OK

Check harness for open or short between ASCD pump and ASCD control unit.

AUTOMATIC SPEED CONTROL DEVICE (ASCD)

Trouble Diagnoses (Cont'd)

DIAGNOSTIC PROCEDURE 8

(ASCD ACTUATOR/PUMP CHECK)

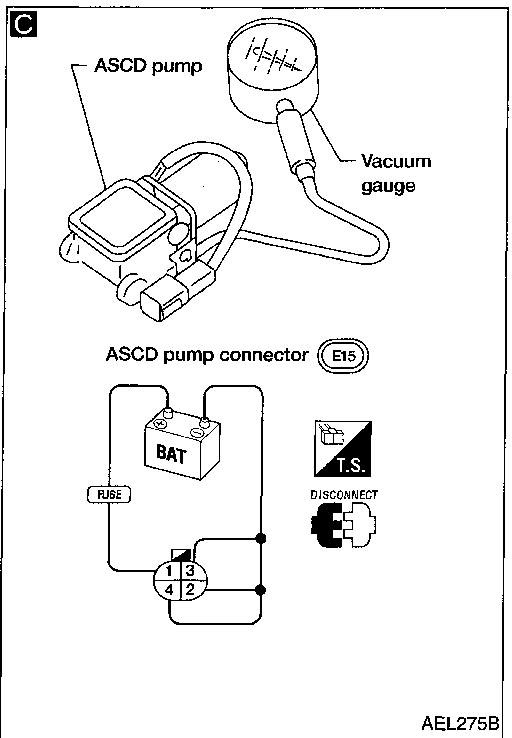
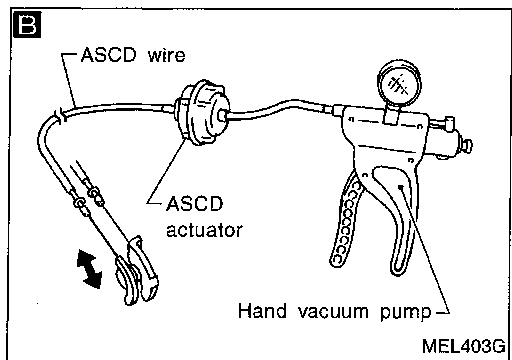
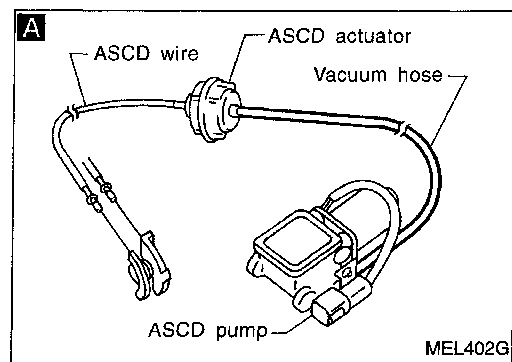

A

CHECK VACUUM HOSE.

Check vacuum hose (between ASCD actuator and ASCD pump) for breakage, cracks or fracture.

NG

Repair or replace hose.

OK

CHECK ASCD WIRE.

Check wire for improper installation, rust formation or breaks.

NG

Repair or replace wire. Refer to "ASCD Wire Adjustment", EL-150.

OK

B

CHECK ASCD ACTUATOR.

1. Disconnect vacuum hose from ASCD actuator.
2. Apply -40 kPa (-0.400 bar , -0.41 kg/cm^2 , -5.8 psi) vacuum to ASCD actuator with hand vacuum pump.

ASCD wire should move to pull throttle drum.

3. Wait 10 seconds and check for decrease in vacuum pressure.

Vacuum pressure decrease:
Less than 2.7 kPa (0.0270 bar , 0.028 kg/cm^2 , 0.39 psi)

NG

Replace ASCD actuator.

OK

C

CHECK ASCD PUMP.

1. Disconnect vacuum hose from ASCD pump and ASCD pump connector.
2. If necessary remove ASCD pump.
3. Connect vacuum gauge to ASCD pump.
4. Apply 12V direct current to ASCD pump and check operation.

NG

Replace ASCD pump.

	12V direct current supply terminals		Operation
	⊕	⊖	
Vacuum motor		②	Operate
Release valve	①	③	Close
Air valve		④	Close

A vacuum pressure of at least -35 kPa (-0.350 bar , -0.36 kg/cm^2 , -5.1 psi) should be generated.

OK

ASCD actuator/pump is OK.

GI

MA

EM

LC

EC

FE

CL

MT

AT

TF

PD

FA

RA

BR

ST

RS

BT

HA

EL

IDX

ASCD Wire Adjustment

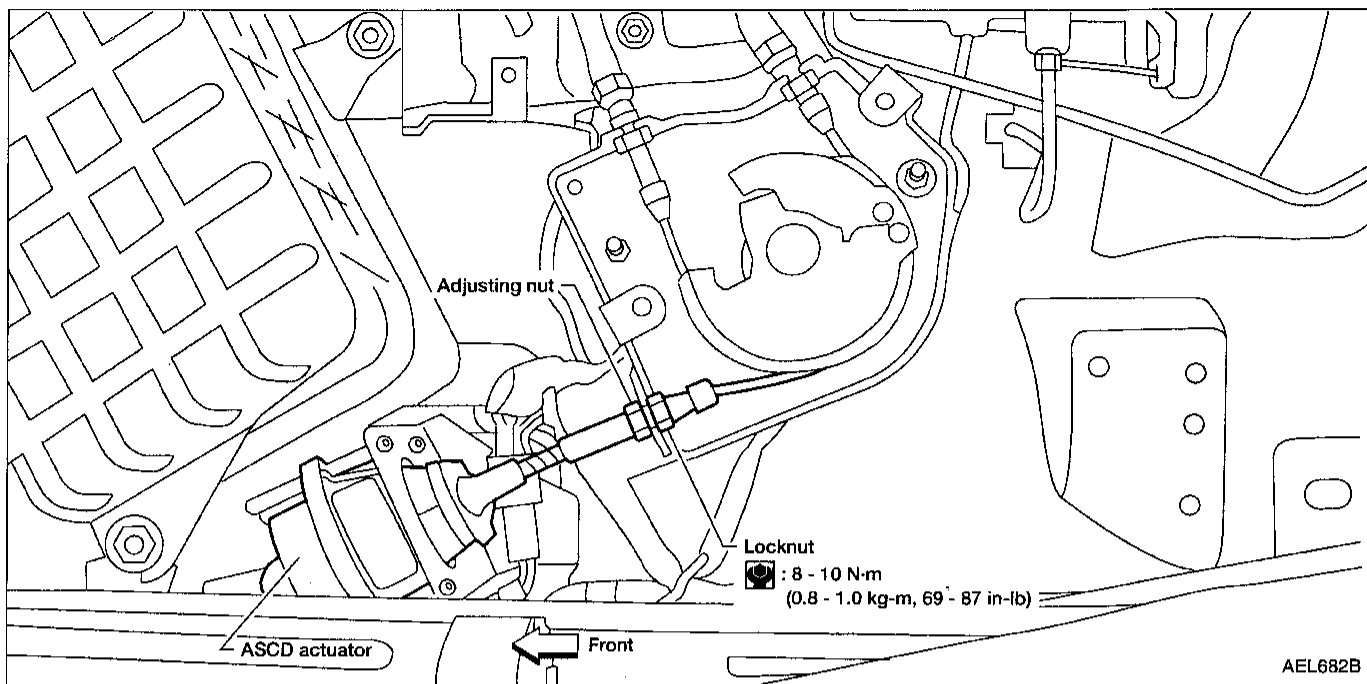

CAUTION:

- Be careful not to twist ASCD wire when removing it.
- Do not tense ASCD wire excessively during adjustment.

Adjust the tension of ASCD wire in the following manner.

- (1) Loosen lock nut and adjusting nut.
- (2) Make sure that accelerator wire is properly adjusted. Refer to FE section ("ACCELERATOR CONTROL SYSTEM").
- (3) Tighten adjusting nut just until throttle drum starts to move.
- (4) Loosen adjusting nut again 1/2 to 1 turn.
- (5) Tighten lock nut.

AUTOMATIC SPEED CONTROL DEVICE (ASCD)

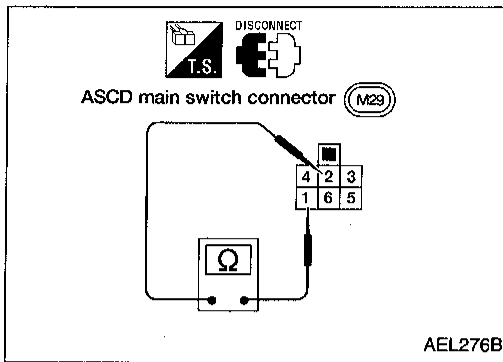

Electrical Components Inspection

ASCD MAIN SWITCH

Check continuity between terminals by pushing switch to each position.

Switch position	Terminals					
	1	2	3	4	5	6
ON	○	○	○	○	ILL.	
N		○	○	○	○	
OFF					○	

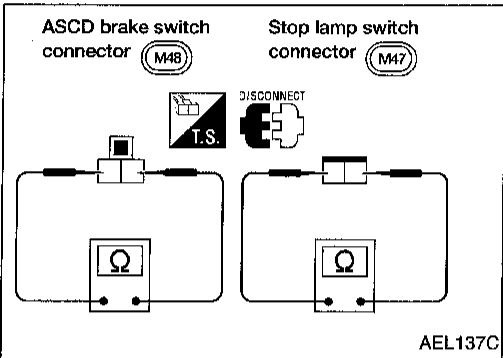

ASCD BRAKE SWITCH AND STOP LAMP SWITCH

Condition	Continuity	
	ASCD brake switch	Stop lamp switch
When brake pedal is depressed	No	Yes
When brake pedal is released	Yes	No

Check each switch after adjusting brake pedal — refer to BR section.

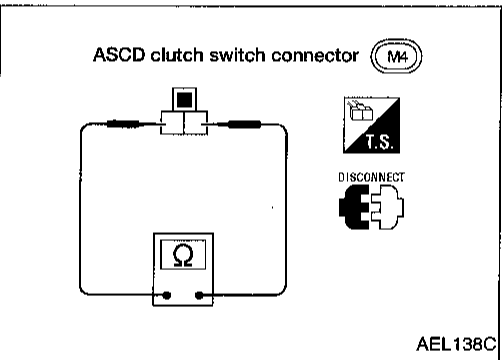

ASCD CLUTCH SWITCH (For M/T models)

Condition	Continuity
When clutch pedal is depressed	No
When clutch pedal is released	Yes

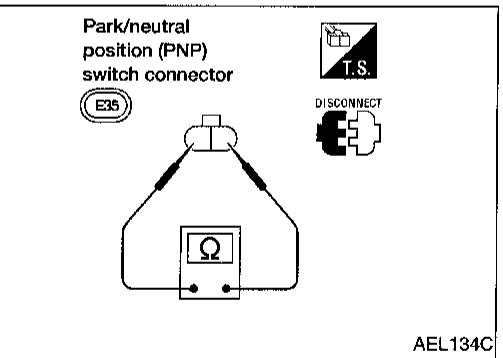

PARK/NEUTRAL POSITION (PNP) SWITCH (For A/T models)

A/T selector lever position	Continuity
	Between terminals
P	Yes
N	Yes
Except P and N	No

GI
MA
EM
LC
EC
FE
CL
MT
AT
TF
PD
FA
RA
BR
ST
RS
BT
HA
EL
IDX

POWER WINDOW

System Description

Power is supplied at all times:

- from 30A fusible link (Letter **f**, located in the fuse and fusible link box)
- to circuit breaker terminal ①
- through circuit breaker terminal ②
- to power window relay terminal ⑤.

With ignition switch in ON or START position, power is supplied:

- through 7.5A fuse [No. ⑤ located in the fuse block (J/B)]
- to power window relay terminal ②.

Ground is supplied to power window relay terminal ①:

- through body grounds **M68** and **M14**.

The power window relay is energized and power is supplied:

- through power window relay terminal ③
- to main power window and door lock/unlock switch terminal ①,
- to power window switch RH terminal ④.

MANUAL OPERATION

Door LH

Ground is supplied:

- through body grounds **M14** and **M68**
- to main power window and door lock/unlock switch terminal ⑤.

WINDOW UP

When the LH switch in the main power window and door lock/unlock switch is pressed in the up position, power is supplied:

- through main power window and door lock/unlock switch terminal ⑬
- to power window motor LH terminal **UP**.

Ground is supplied:

- through main power window and door lock/unlock switch terminal ⑮
- to power window motor LH terminal **DN**.

Then, the motor raises the window until the switch is released.

WINDOW DOWN

When the LH switch in the main power window and door lock/unlock switch is pressed in the down position, power is supplied:

- through main power window and door lock/unlock switch terminal ⑮
- to power window motor LH terminal **DN**.

Ground is supplied:

- through main power window and door lock/unlock switch terminal ⑬
- to power window motor LH terminal **UP**.

Then, the motor lowers the window until the switch is released.

Door RH

Ground is supplied:

- through body grounds **M14** and **M68**
- to main power window and door lock/unlock switch terminal ⑤.

NOTE:

Numbers in parentheses are terminal numbers, when power window switch is pressed in the UP and DOWN positions respectively.

MAIN SWITCH OPERATION

Power is supplied:

- through main power window and door lock/unlock switch terminal (⑭, ⑬)
- to power window switch RH terminal (⑤, ②).

The subsequent operation is the same as the power window switch operation.

POWER WINDOW

System Description (Cont'd)

POWER WINDOW SWITCH OPERATION

Power is supplied:

- to power window switch RH terminal (4)
- through power window switch RH terminal (6, 3)
- to power window motor RH terminal (UP, DN).

Ground is supplied:

- to power window motor RH terminal (DN, UP)
- through power window switch RH terminal (3, 6)
- through power window switch RH terminal (2, 5)
- through main power window and door lock/unlock switch terminal (13, 14).

Then, the motor raises or lowers the window until the switch is released.

AUTO OPERATION

The power window AUTO feature enables the driver to lower the driver's window without holding the window switch in the down position.

The AUTO feature only operates on the driver's window downward movement.

POWER WINDOW LOCK

The power window lock is designed to lock operation of the RH door window.

When the lock switch is pressed to lock position, ground of the power window switch RH in the main power window and door lock/unlock switch is disconnected. This prevents the power window motor RH from operating.

GI

MA

EM

LC

EC

FE

CL

MT

AT

TF

PD

FA

RA

BR

ST

RS

BT

HA

EL

IDX

POWER WINDOW

Wiring Diagram — WINDOW —

EL-WINDOW-01

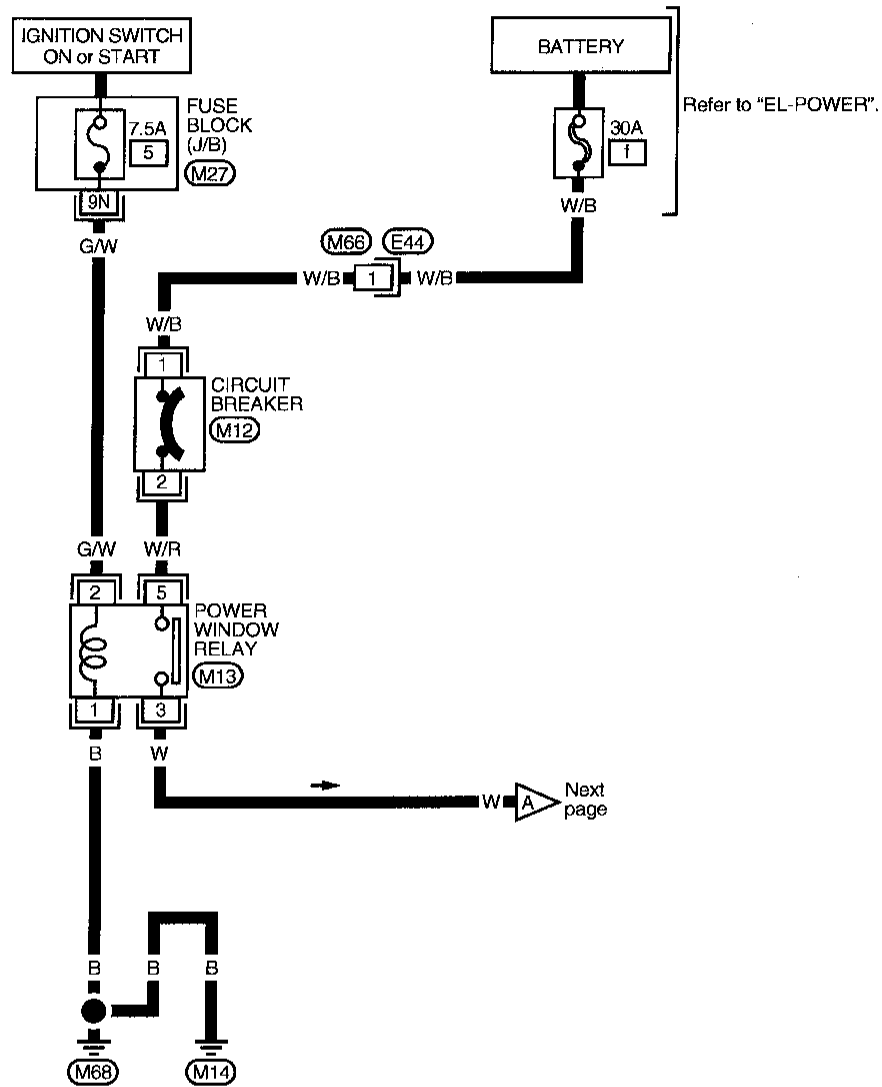

POWER WINDOW

Wiring Diagram — WINDOW — (Cont'd)

EL-WINDOW-02

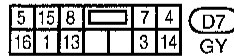
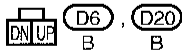
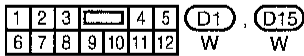
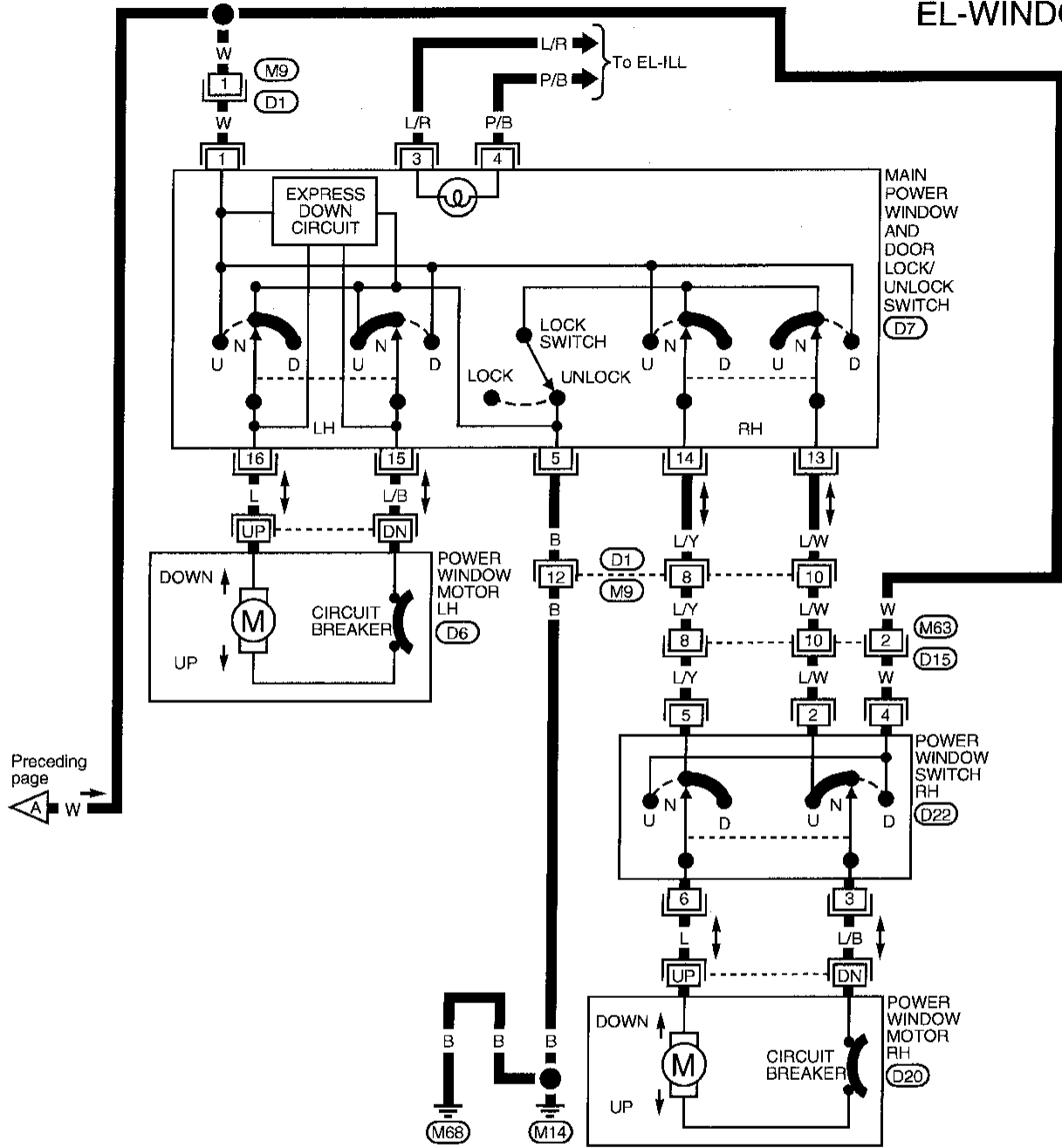

GI
MA
EM
LC
EC
FE
CL
MT
AT
TF
PD
FA
RA
BR
ST
RS
BT
HA
EL
IDX

POWER WINDOW

Trouble Diagnoses

Symptom	Possible cause	Repair order
None of the power windows can be operated using any switch.	<ol style="list-style-type: none"> 1. 7.5A fuse, 30A fusible link and M12 circuit breaker 2. Grounds M14 and M68 3. Power window relay 4. Open/short in main power window switch circuit 	<ol style="list-style-type: none"> 1. Check 7.5A fuse (No. 5), located in fuse block (J/B), 30A fusible link (letter f), located in fuse and fusible link box) and M12 circuit breaker. Turn ignition switch ON and verify battery positive voltage is present at terminal 1 of main power window switch and terminal 4 of passenger switch. 2. Check grounds M14 and M68. 3. Check power window relay. 4. Check W wire between power window relay and main power window switch for open/short circuit.
Driver side power window cannot be operated but passenger window can be operated.	<ol style="list-style-type: none"> 1. Driver side power window motor circuit 2. Driver side power window motor 	<ol style="list-style-type: none"> 1. Check harness between main power window switch and power window motor LH for open or short circuit. 2. Check power window motor LH.
Passenger power window cannot be operated.	<ol style="list-style-type: none"> 1. Passenger power window switch 2. Passenger power window motor 3. Main power window switch 4. Power window circuit 	<ol style="list-style-type: none"> 1. Check passenger power window switch. 2. Check passenger power window motor. 3. Check main power window switch. 4-1. Check harnesses between main power window switch and passenger power window switch for open/short circuit. 4-2. Check harnesses between passenger power window switch and passenger power window motor for open/short circuit.
Passenger power window cannot be operated using main power window switch but can be operated by passenger power window switch.	<ol style="list-style-type: none"> 1. Main power window switch 	<ol style="list-style-type: none"> 1. Check main power window switch.
Driver side power window auto function cannot be operated using main power window switch.	<ol style="list-style-type: none"> 1. Main power window switch 	<ol style="list-style-type: none"> 1. Check main power window switch.

POWER DOOR LOCK

Component Parts and Harness Connector Location

GI
MA
EM
LC
EC
FE
CL
MT
AT
TF
PD
FA
RA
BR
ST
RS
BT
HA
EL
IDX

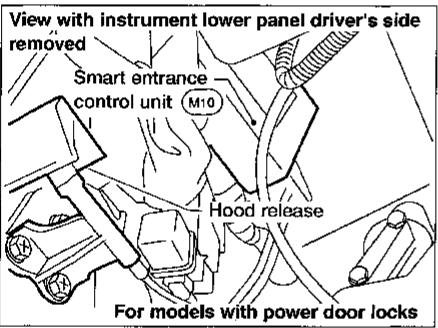
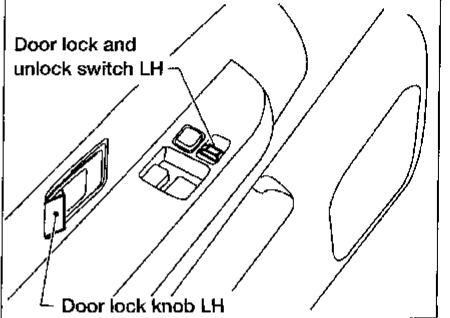
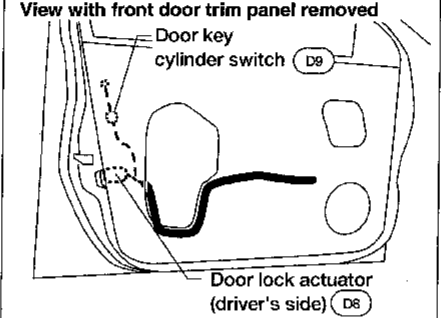
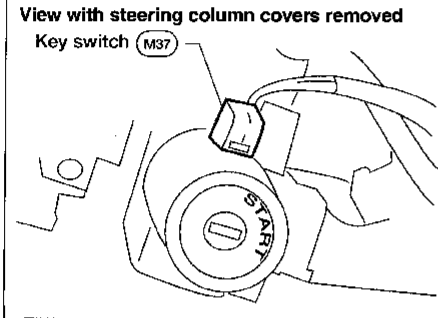
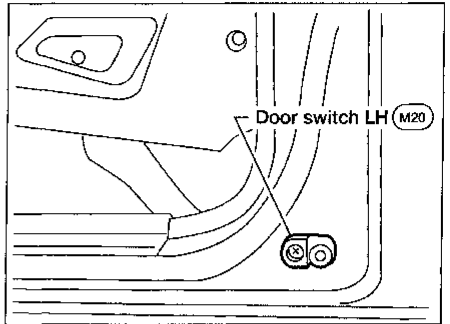
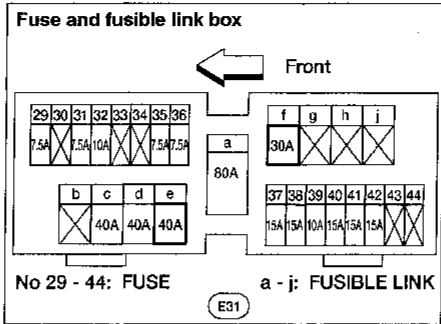
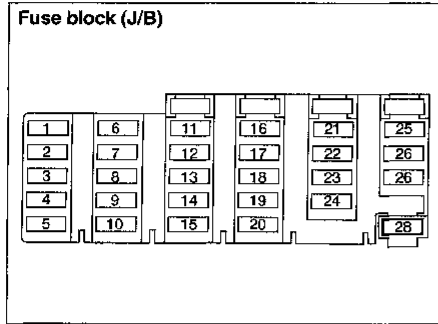

POWER DOOR LOCK

System Description

Power is supplied at all times:

- through 30A fusible link (Letter **F**, located in the fuse and fusible link box)
- to circuit breaker terminal ①
- through circuit breaker terminal ②
- to smart entrance control unit terminal ①.

Power is supplied at all times:

- through 7.5A fuse [No. 28, located in the fuse block (J/B)]
- to key switch terminal ①.

Ground is supplied:

- through body grounds **M14** and **M68**
- to smart entrance control unit terminal ⑩.

INPUT

Power is supplied through key switch terminal ② to smart entrance control unit terminal ②④ when the ignition key is inserted in the key switch.

Ground is supplied:

- through RH door switch terminal ① when RH door is open
- to smart entrance control unit terminal ③⑤.

Ground is supplied:

- through body grounds **M14** and **M68**
- to LH door switch terminal ③
- through LH door switch terminal ② when LH door is open
- to smart entrance control unit terminal ①⑤.

Ground is supplied:

- through body grounds **M14** and **M68**
- through LH or RH door key cylinder switch terminal ② when door key cylinder is BETWEEN FULL STROKE AND N (to unlock position)
- from LH door key cylinder switch terminal ③ or RH door key cylinder switch terminal ①
- to smart entrance control unit terminal ③①.

Ground is supplied:

- through body grounds **M14** and **M68**
- through LH or RH door key cylinder switch terminal ② when door key cylinder is BETWEEN FULL STROKE AND N (to lock position)
- from LH door key cylinder switch terminal ① or RH door key cylinder switch terminal ③
- to smart entrance control unit terminal ③⑩.

Ground is supplied:

- through body grounds **M14** and **M68**
- from door unlock sensor (in the LH or RH door lock actuator) terminal ④ when door lock is in UNLOCKED position
- through door unlock sensor (in the LH or RH door lock actuator) terminal ②
- to smart entrance control unit terminal ⑫ or ⑬.

Ground is supplied:

- through body grounds **M14** and **M68**
- through main power window and door lock/unlock switch terminal ⑤ (when switch is pressed in lock or unlock position)
- from main power window and door lock/unlock switch terminal ⑦ or ⑧
- to smart entrance control unit terminal ⑱ or ⑲.

Ground is also supplied from door lock/unlock switch RH in the same manner as main power window and door lock/unlock switch.

POWER DOOR LOCK

System Description (Cont'd)

OUTPUT

Unlock

Power is supplied:

- from smart entrance control unit terminal ③
- to LH door lock actuator terminal ①.

Power is supplied:

- from smart entrance control unit terminal ②
- to RH door lock actuator terminal ①.

Ground is supplied:

- from smart entrance control unit terminal ④
- to LH and RH door lock actuator terminals ③.

With power and ground supplied, the door actuators move to the unlocked position.

Lock

Power is supplied:

- from smart entrance control unit terminal ④
- to LH and RH door lock actuator terminals ③.

Ground is supplied:

- from smart entrance control unit terminal ③
- to LH door lock actuator terminal ①.

Ground is supplied:

- from smart entrance control unit terminal ②
- to RH door lock actuator terminal ①.

With power and ground supplied, the door actuators move to the locked position.

OPERATION

- The lock and unlock switch on driver's door trim can lock and unlock both doors.
- With the lock knob on LH or RH door set to LOCKED, all doors are locked (signal from door unlock sensor).
- With the door key inserted in the key cylinder on LH or RH door, turning it to LOCK will lock both doors; turning it to UNLOCK once unlocks the corresponding door; turning it to UNLOCK again within 5 seconds after the first unlock operation unlocks the other door (signal from door key cylinder switch).

However, if the ignition key is in the ignition key cylinder and one or more of the doors are open, setting the lock and unlock switch, lock knob, or the door key to LOCK locks the doors once but then immediately unlocks them (combination signals from key switch, LH or RH door switch and LH or RH door unlock sensor). — (KEY REMINDER DOOR SYSTEM)

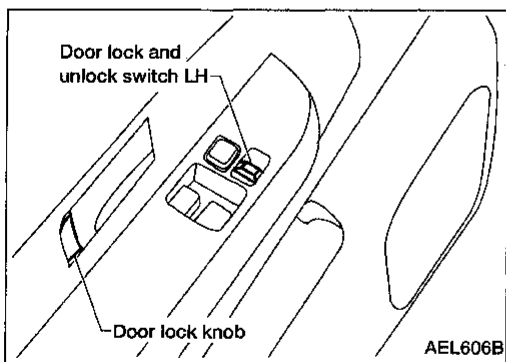

GI

MA

EM

LC

EC

FE

CL

MT

AT

TF

PD

FA

RA

BR

ST

RS

BT

HA

EL

IDX

POWER DOOR LOCK

Schematic

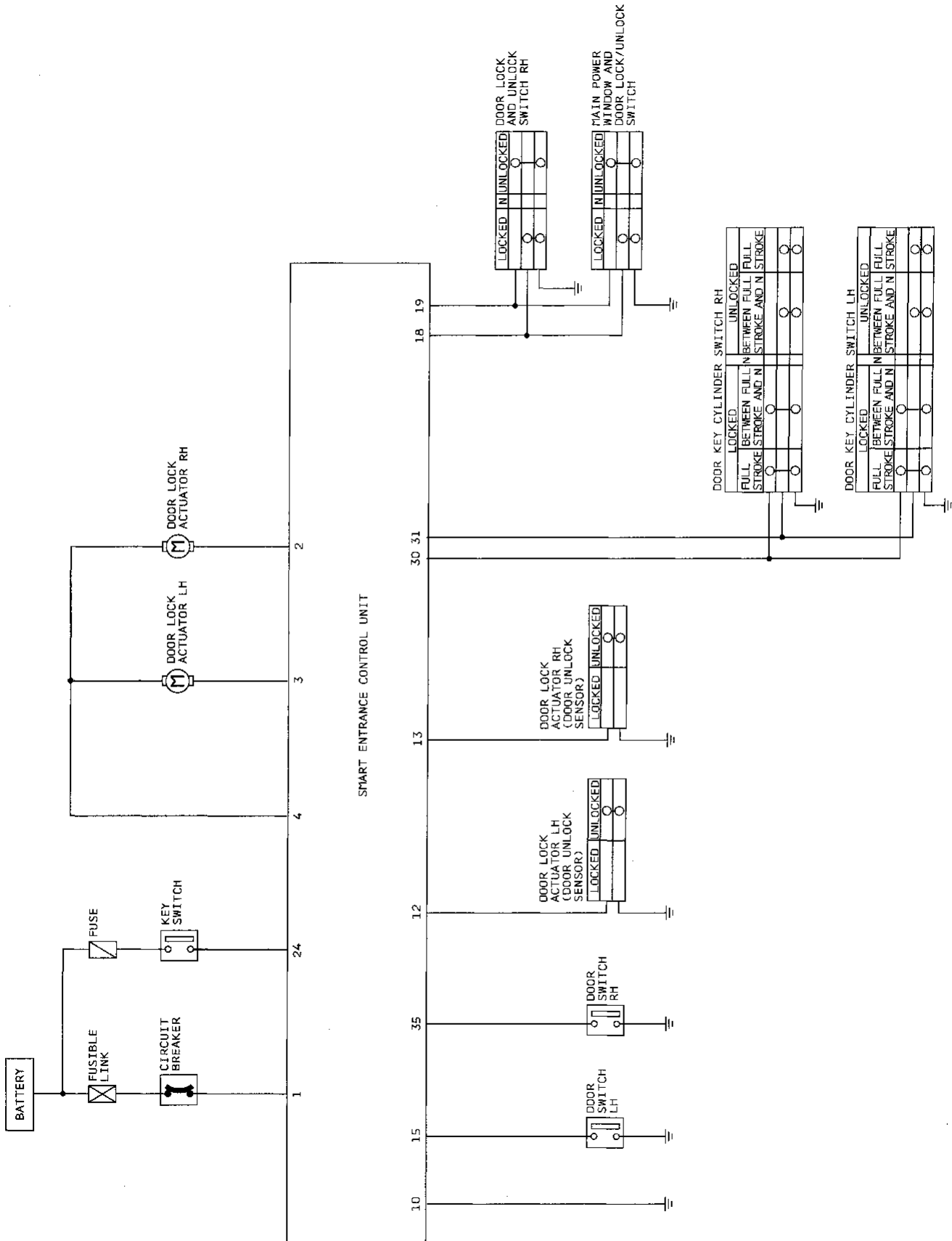

POWER DOOR LOCK

Wiring Diagram — D/LOCK —

EL-D/LOCK-01

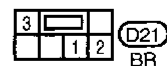
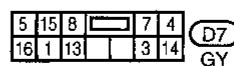
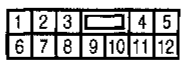
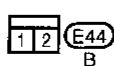
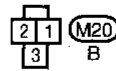
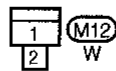
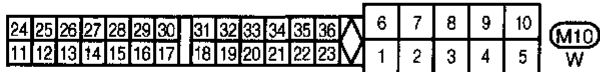
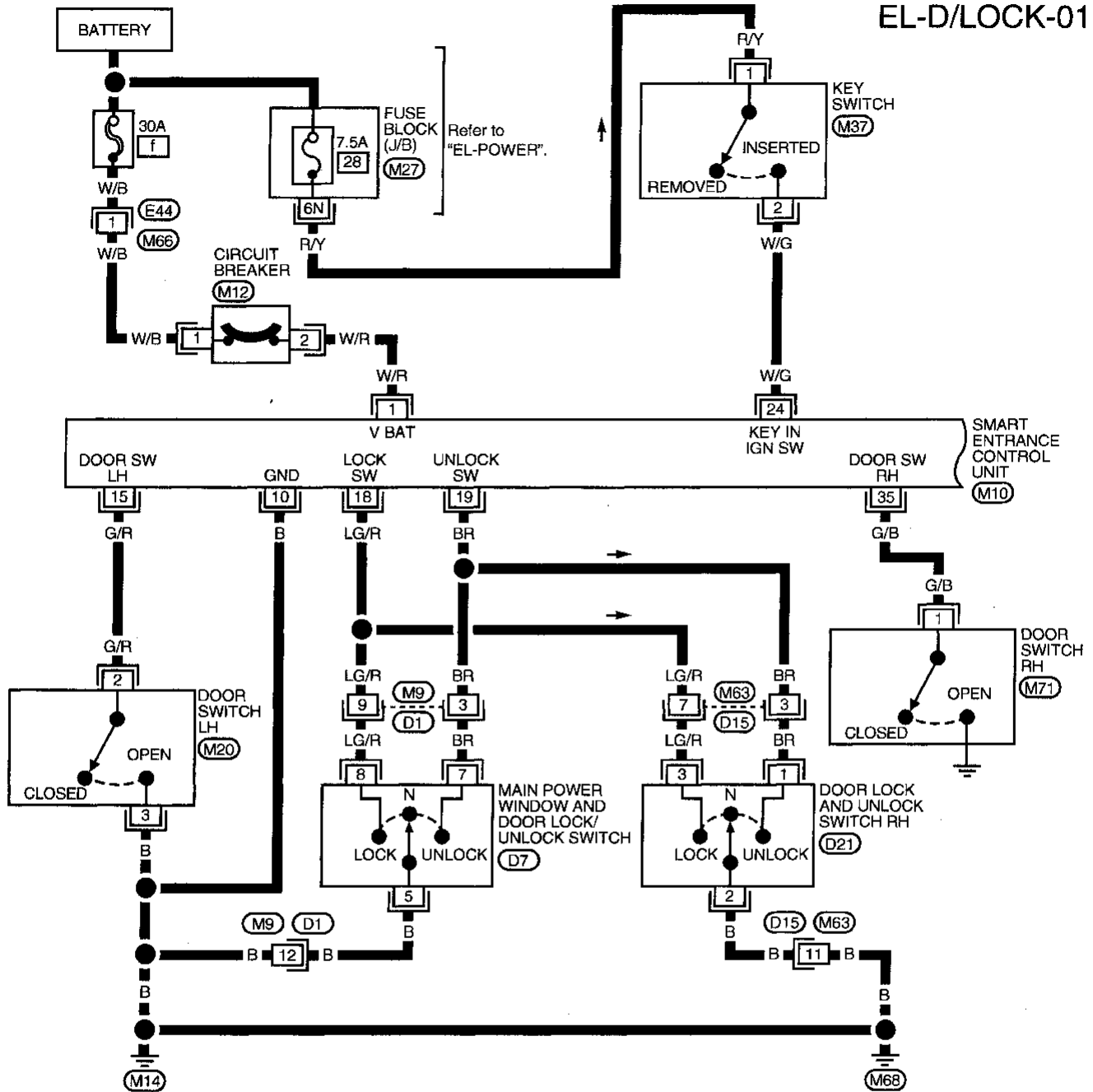

GI
MA
EM
LC
EC
FE
CL
MT
AT
TF
PD
FA
RA
BR
ST
RS
BT
HA
EL
IDX

POWER DOOR LOCK

Wiring Diagram — D/LOCK — (Cont'd)

EL-D/LOCK-02

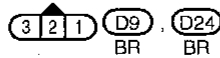
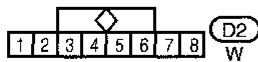
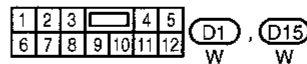
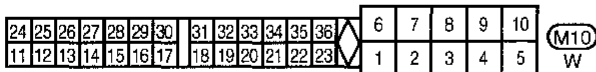
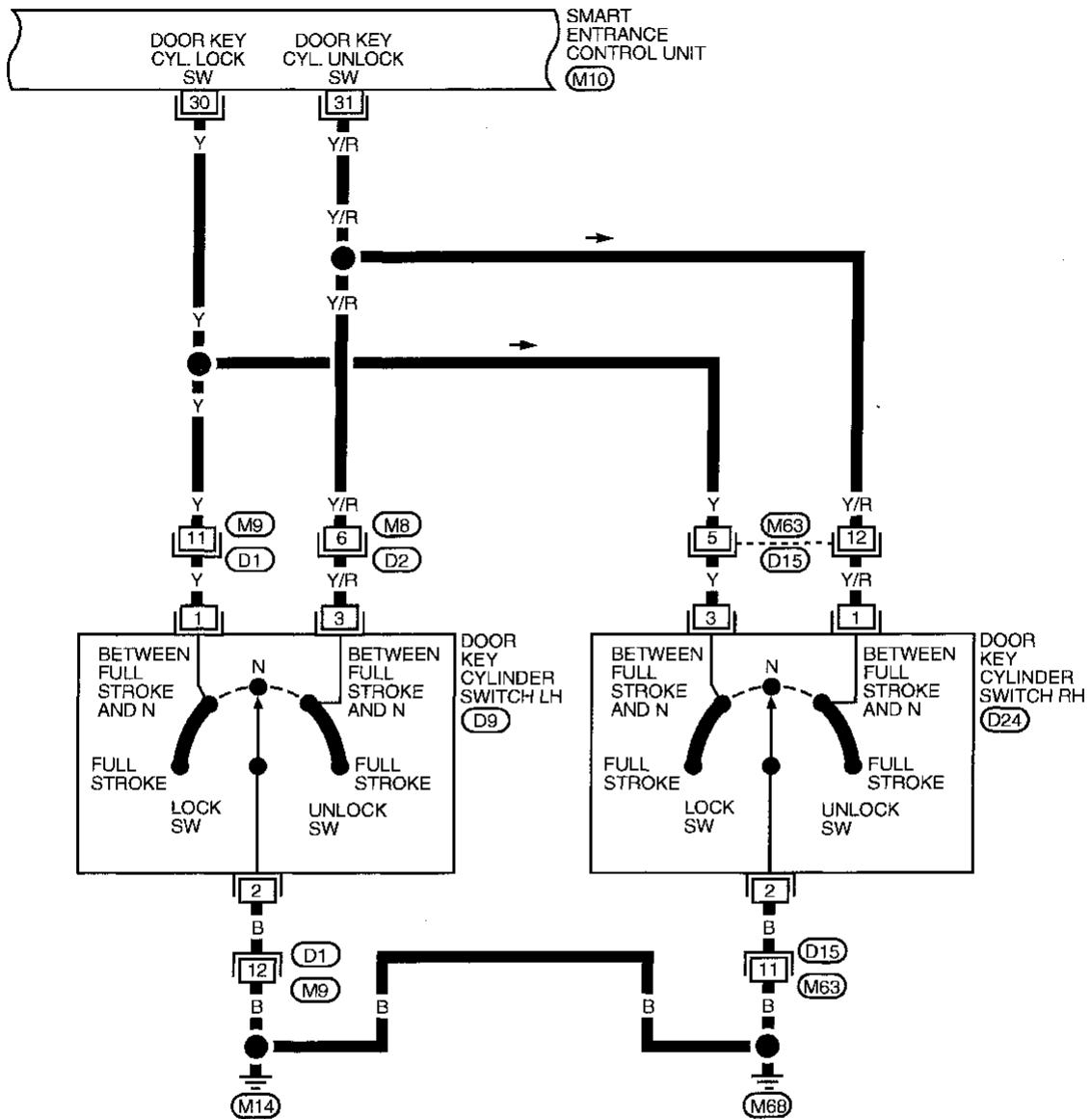

POWER DOOR LOCK

Wiring Diagram — D/LOCK — (Cont'd)

EL-D/LOCK-03

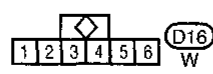
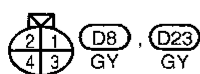
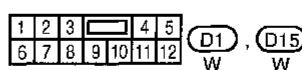
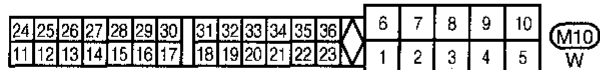
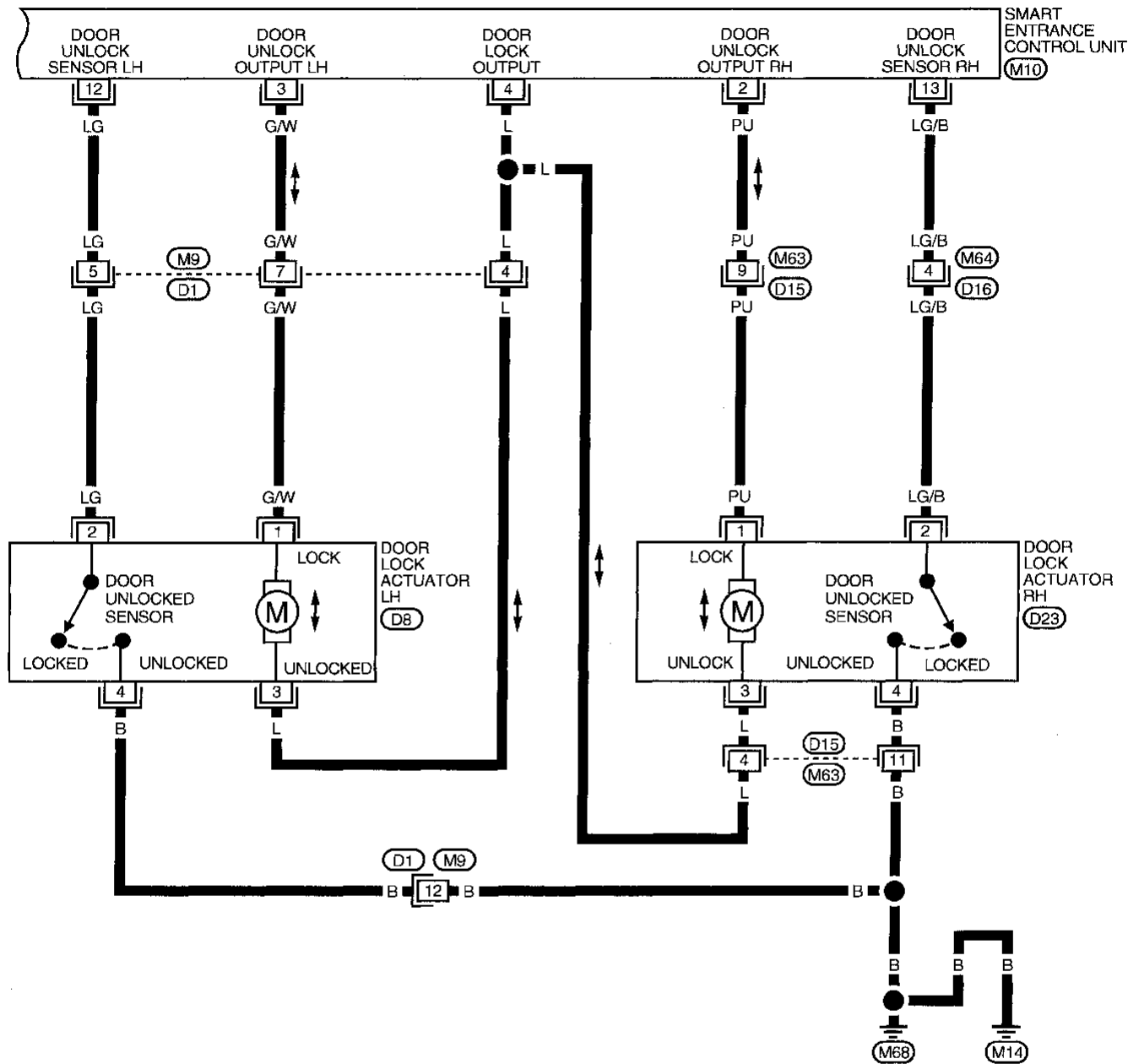

GI
MA
EM
LC
EC
FE
CL
MT
AT
TF
PD
FA
RA
BR
ST
RS
BT
HA
EL
IDX

POWER DOOR LOCK

Trouble Diagnoses

SYMPTOM CHART

PROCEDURE	Main power supply and ground circuit check		Diagnostic procedure					
	EL-165	EL-165	EL-166	EL-167	EL-168	EL-169	EL-170	EL-171
REFERENCE PAGE	EL-165	EL-165	EL-166	EL-167	EL-168	EL-169	EL-170	EL-171
SYMPTOM	Main power supply circuit check	Ground circuit check	Procedure 1 (Door switch check)	Procedure 2 [Key switch (insert) check]	Procedure 3 (Door lock/unlock switch check)	Procedure 4 (Door key cylinder switch check)	Procedure 5 (Door unlock sensor check)	Procedure 6 (Door lock actuator check)
Key reminder door system does not operate properly.	X	X	X	X			X	X
One or more doors are not locked and/or unlocked.	X	X					X	X
Lock & unlock switch does not operate.	X	X			X			
None of the doors lock/unlock when operating door key cylinder switch.	X	X				X		
None of the doors lock when operating door knob lock switch.	X	X					X	

X: Applicable

Perform "Main Power Supply and Ground Circuit Check" before starting with power door lock diagnostic procedure.

POWER DOOR LOCK

Trouble Diagnoses (Cont'd)

MAIN POWER SUPPLY AND GROUND CIRCUIT CHECK

Main power supply circuit check

Terminal		Ignition switch		
⊕	⊖	OFF	ACC	ON
①	Ground	Battery voltage	Battery voltage	Battery voltage

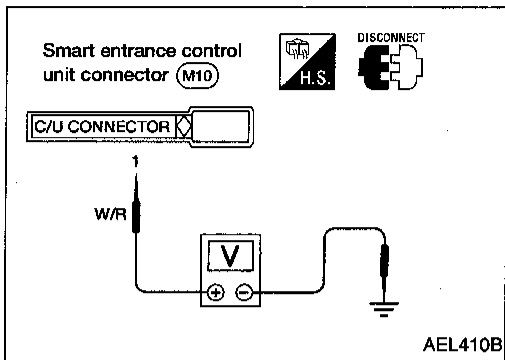

Ground circuit check

Terminals	Continuity
⑩ - Ground	Yes

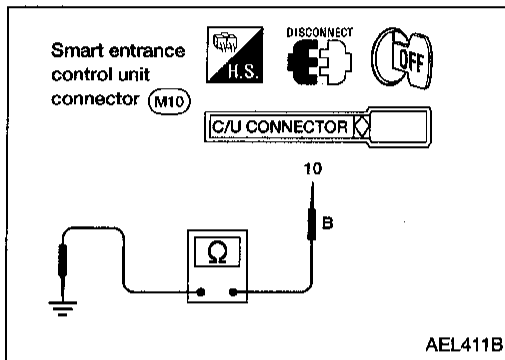

GI

MA

EM

LC

EC

FE

CL

MT

AT

TF

PD

FA

RA

BR

ST

RS

BT

HA

EL

IDX

POWER DOOR LOCK

Trouble Diagnoses (Cont'd)

DIAGNOSTIC PROCEDURE 1 (Door switch check)

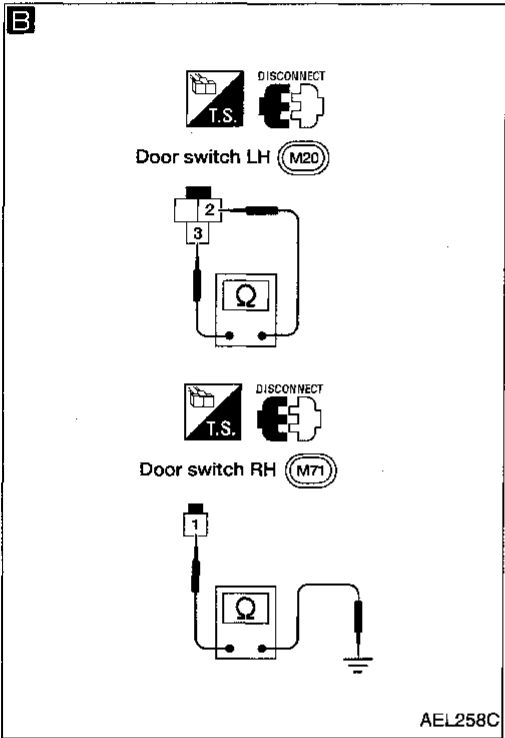
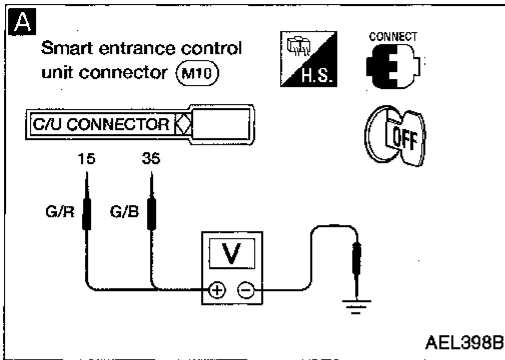

A

CHECK DOOR SWITCH INPUT SIGNAL.
Check voltage between control unit terminals (15) or (35) and ground.

OK → Door switch is OK.

	Terminals		Condi- tion	Voltage [V]
	⊕	⊖		
Door switch LH	(15)	Ground	Open	0
			Closed	Approx. 12
Door switch RH	(35)	Ground	Open	0
			Closed	Approx. 12

Refer to wiring diagram in EL-161.

NG

B

CHECK DOOR SWITCH.
1. Disconnect door switch connector.
2. Check continuity between door switch terminals.

NG → Replace door switch.

	Terminals	Condition	Continuity
Door switch LH	(2) - (3)	Closed	No
		Open	Yes
Door switch RH	(1) - Ground	Closed	No
		Open	Yes

OK

Check the following.

- Door switch ground circuit (LH) or door switch ground condition
- Harness for open or short between control unit and door switch

POWER DOOR LOCK

Trouble Diagnoses (Cont'd)

DIAGNOSTIC PROCEDURE 2 [Key switch (insert) check]

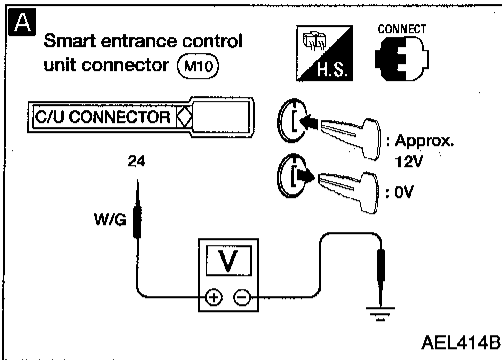

A

CHECK KEY SWITCH INPUT SIGNAL.
Check voltage between control unit terminal (24) and ground.

Condition of key switch	Voltage [V]
Key is inserted.	Approx. 12
Key is withdrawn.	0

Refer to wiring diagram in EL-161.

OK → Key switch (insert) is ok.

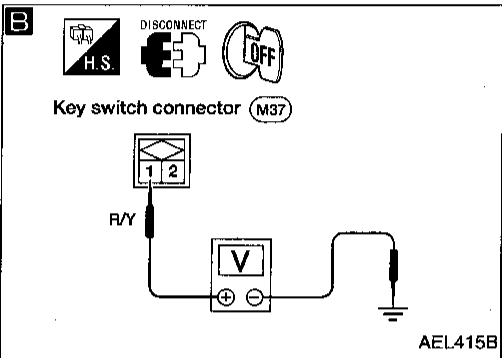

B

CHECK KEY SWITCH POWER SUPPLY.
1. Disconnect key switch connector.
2. Check voltage between key switch harness terminal (1) and ground.
Battery voltage should exist.

NG → Check the following.

- 7.5A fuse [No. 28], located in fuse block (J/B)]
- Harness for open or short between key switch and fuse

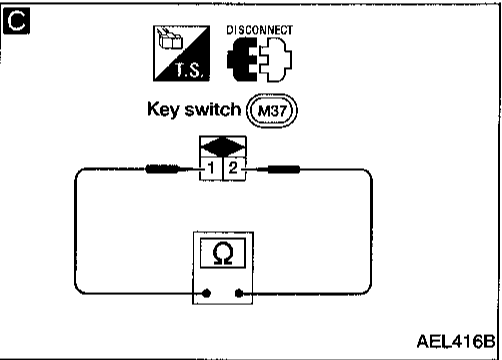

C

CHECK KEY SWITCH.
Check continuity between key switch terminals.

Terminals	Condition	Continuity
① - ②	Key is inserted.	Yes
	Key is withdrawn.	No

NG → Replace key switch.

OK → Check harness for open or short between control unit and key switch.

GI
MA
EM
LC
EC
FE
CL
MT
AT
TF
PD
FA
RA
BR
ST
RS
BT
HA
EL
IDX

POWER DOOR LOCK

Trouble Diagnoses (Cont'd)

DIAGNOSTIC PROCEDURE 3

(Door lock/unlock switch check)

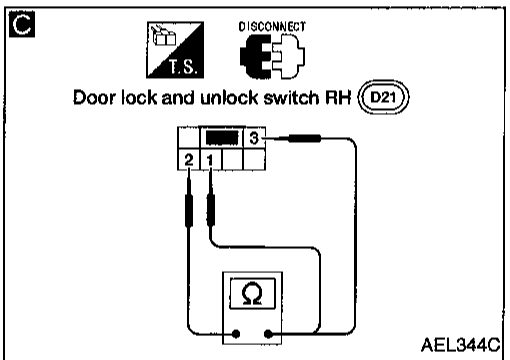
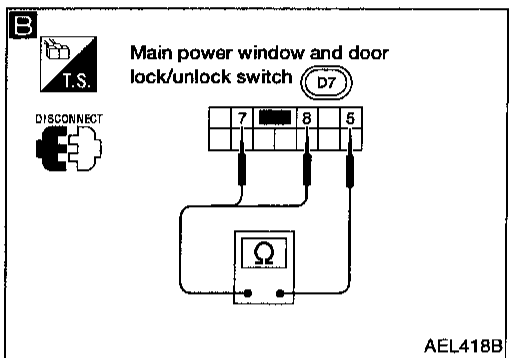
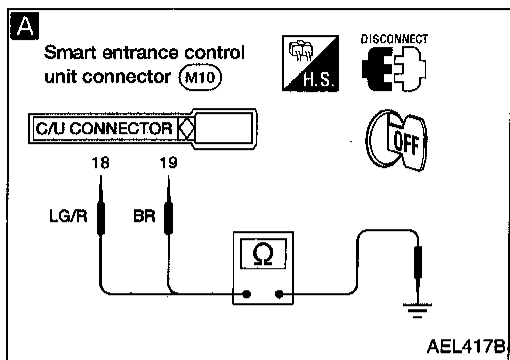

A CHECK DOOR LOCK/UNLOCK SWITCH INPUT SIGNAL.

1. Disconnect control unit connector.
2. Check continuity between control unit terminal (18) or (19) and ground.

Terminals	Door lock/unlock switch (LH or RH) condition	Continuity
(18) - Ground	Lock	Yes
	N and Unlock	No
(19) - Ground	Unlock	Yes
	N and Lock	No

Refer to wiring diagram in EL-161.

OK → Door lock/unlock switch is OK.

NG ↓

B C CHECK LH OR RH DOOR LOCK/UNLOCK SWITCH.

1. Disconnect main power window and door lock/unlock switch connector.
2. Check continuity between main power window and door lock/unlock switch terminals.

B Driver side

Condition	Terminals		
	5	7	8
Lock	○	○	○
N	No continuity		
Unlock	○	○	

NG → Replace main power window and door lock/unlock switch or door lock and unlock switch RH.

3. Disconnect door lock and unlock switch RH connector.
4. Check continuity between door lock and unlock switch RH terminals.

C Passenger side

Condition	Terminals		
	1	2	3
Lock		○	○
N	No continuity		
Unlock	○	○	

OK ↓

- Check the following.
- Ground circuit for door lock/unlock switch
 - Harness for open or short between door lock/unlock switch and control unit connector

POWER DOOR LOCK

Trouble Diagnoses (Cont'd)

DIAGNOSTIC PROCEDURE 4 (Door key cylinder switch check)

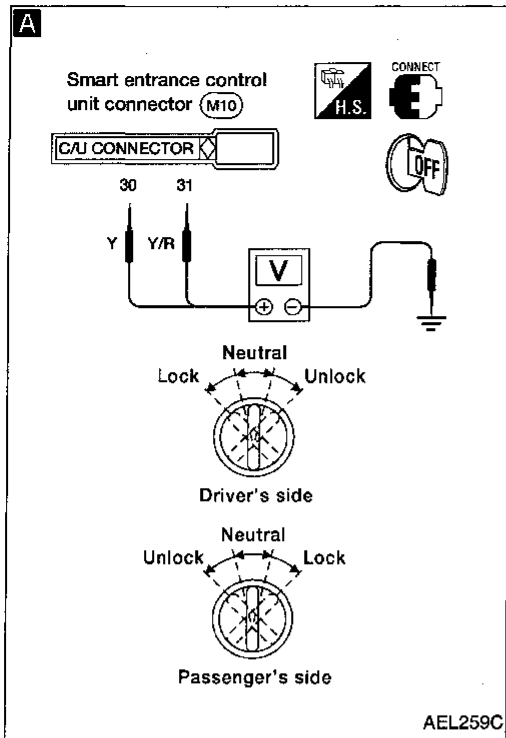

A

CHECK DOOR KEY CYLINDER SWITCH INPUT SIGNAL (LOCK/UNLOCK SIGNAL).

Check voltage between control unit terminals ③⑩ or ③⑪ and ground.

Terminals		Key position	Voltage [V]
⊕	⊖		
③⑩	Ground	Neutral	Approx. 12
		Lock	0
③⑪	Ground	Neutral	Approx. 12
		Unlock	0

Refer to wiring diagram in EL-162.

OK → Door key cylinder switch is OK.

NG

B

CHECK DOOR KEY CYLINDER SWITCH.

1. Disconnect door key cylinder switch connector.
2. Check continuity between door key cylinder switch terminals.

Terminals	Key position	Continuity
LH: ① - ②	Neutral	No
RH: ③ - ②	Lock	Yes
LH: ③ - ②	Neutral	No
RH: ① - ②	Unlock	Yes

NG → Replace door key cylinder switch.

OK

Check the following.

- Door key cylinder switch ground circuit
- Harness for open or short between control unit and door key cylinder switch

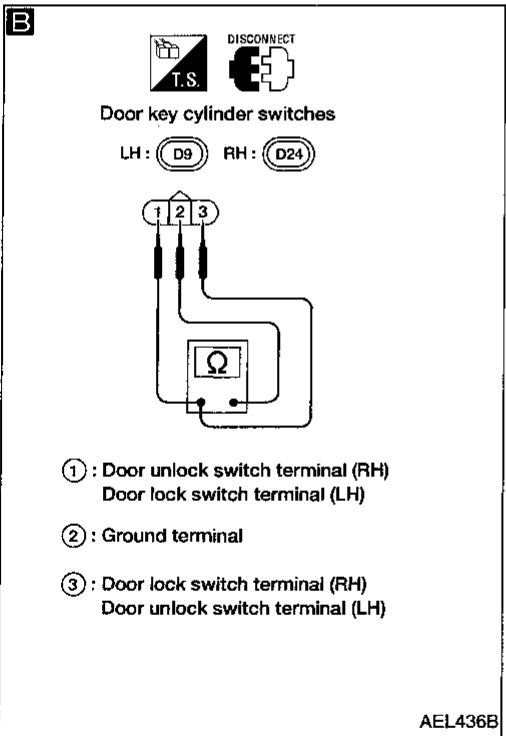

GI
MA
EM
LC
EC
FE
CL
MT
AT
TF
PD
FA
RA
BR
ST
RS
BT
HA
EL
IDX

POWER DOOR LOCK

Trouble Diagnoses (Cont'd)

DIAGNOSTIC PROCEDURE 5 (Door unlock sensor check)

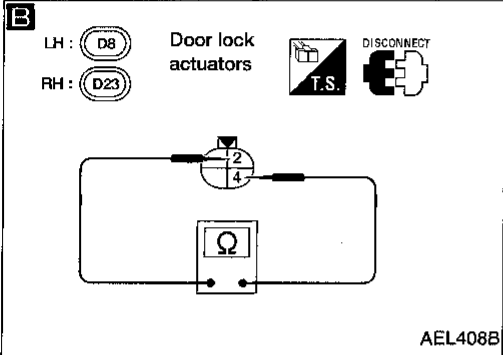
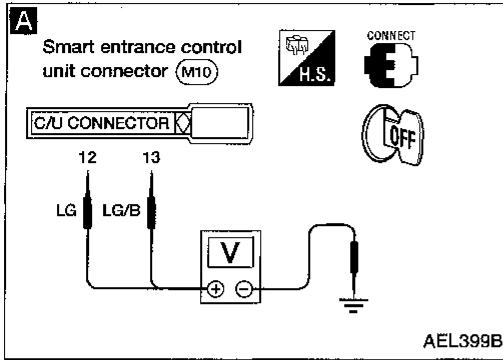

A

CHECK DOOR UNLOCK SENSOR INPUT SIGNAL.
Check voltage between control unit terminals (12), (13) and ground.

	Terminals		Condition	Voltage [V]
	⊕	⊖		
LH door	(12)	Ground	Locked	Approx. 12
			Unlocked	0
RH door	(13)	Ground	Locked	Approx. 12
			Unlocked	0

Refer to wiring diagram in EL-163.

OK → Door unlock sensor is OK.

B

CHECK DOOR UNLOCK SENSOR.
1. Disconnect door unlock sensor connector.
2. Check continuity between door unlock sensor terminals.

Terminals	Condition	Continuity
(4) - (2)	Locked	No
	Unlocked	Yes

NG → Replace door unlock sensor.

OK

Check the following.

- Door unlock sensor ground circuit
- Harness for open or short between control unit and door unlock sensor

POWER DOOR LOCK

Trouble Diagnoses (Cont'd)

DIAGNOSTIC PROCEDURE 6

(Door lock actuator check)

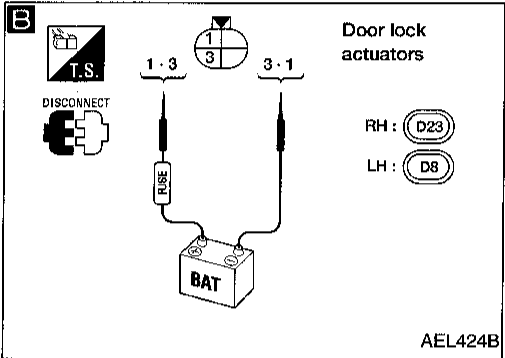
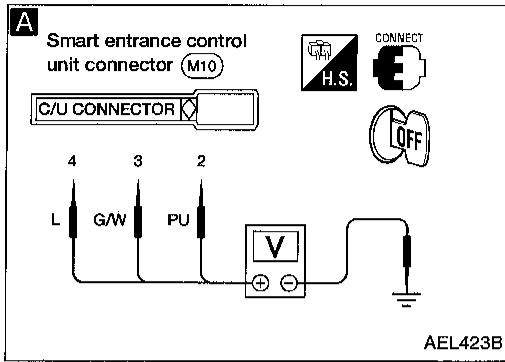

A **CHECK DOOR LOCK ACTUATOR OUTPUT.**
Check voltage for door lock actuator.

Door lock/unlock switch condition	Terminals		Voltage (V)
	⊕	⊖	
Lock	④	Ground	Battery voltage
Unlock	③, ②	Ground	Battery voltage

Refer to wiring diagram in EL-163.

NG → Replace smart entrance control unit. (Before replacing control unit, perform other procedures following SYMPTOM CHART.)

OK ↓

B **CHECK DOOR LOCK ACTUATOR.**
1. Disconnect door lock actuator connector.
2. Apply 12V direct current to door lock actuator and check operation.

Door lock actuator operation	Terminals	
	⊕	⊖
Unlocked → Locked	③	①
Locked → Unlocked	①	③

NG → Replace door lock actuator.

OK ↓

Check harness for open or short between control unit connector and door lock actuator.

GI
MA
EM
LC
EC
FE
CL
MT
AT
TF
PD
FA
RA
BR
ST
RS
BT
HA
EL
IDX

Component Parts and Harness Connector Location

Fuse block (J/B)

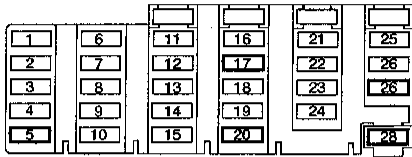

Fuse and fusible link box

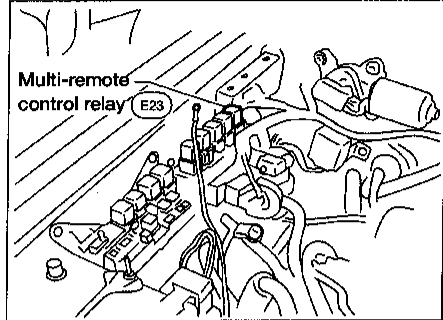
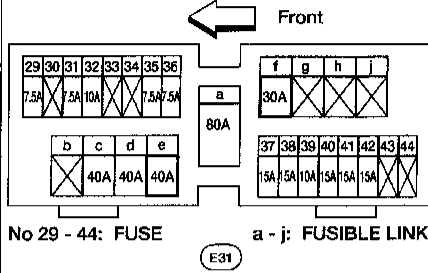

View with door trim panel removed

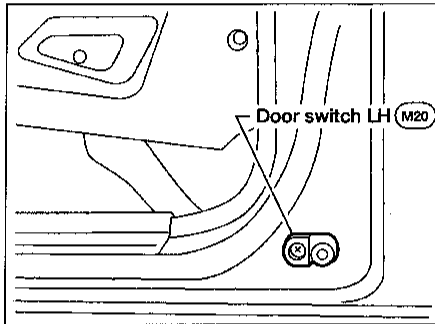
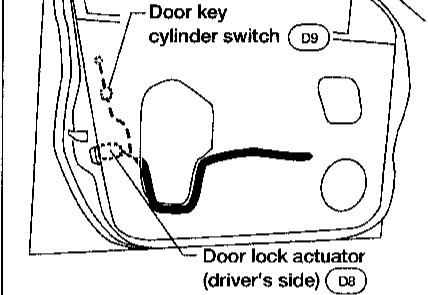

View with steering column covers removed

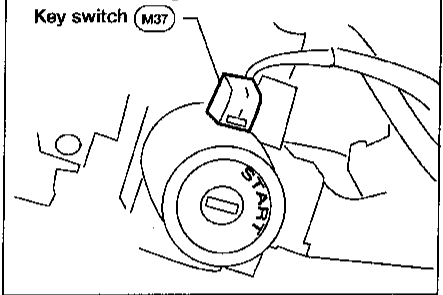

View with instrument lower panel driver's side removed

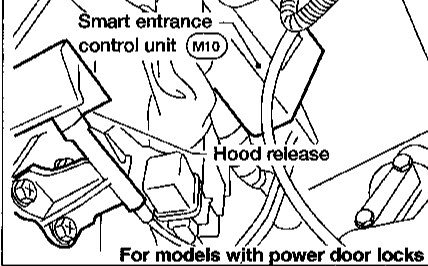

System Description

POWER SUPPLY AND GROUND

Power is supplied at all times:

- through 30A fusible link (letter **f**, located in the fuse and fusible link box)
- to circuit breaker terminal **①**
- through circuit breaker terminal **②**
- to smart entrance control unit terminal **①**.

Power is supplied at all times:

- through 7.5A fuse [No. **26**, located in the fuse block (J/B)]
- to interior lamp terminal **+**

Power is supplied at all times:

- through 7.5A fuse [No. **28**, located in the fuse block (J/B)]
- to key switch terminal **①**.

Power is supplied at all times:

- through 10A fuse [No. **17**, located in the fuse block (J/B)]
- to multi-remote control relay terminals **②**, **⑤** and **⑦**.

With the ignition switch in the ON or START position, power is supplied:

- through 7.5A fuse [No. **5**, located in the fuse block (J/B)]
- to smart entrance control unit terminal **⑪**.

With the ignition switch in the ACC or ON position, power is supplied:

- through 7.5A fuse [No. **20**, located in the fuse block (J/B)]
- to smart entrance control unit terminal **⑰**.

Ground is supplied:

- to smart entrance control unit terminal **⑩**
- through body grounds **M14** and **M68**.

INPUTS

When the key switch is ON (ignition key is inserted in key cylinder), power is supplied:

- through key switch terminal **②**
- to smart entrance control unit terminal **24**.

When the door switch LH is OPEN, ground is supplied:

- to smart entrance control unit terminal **15**
- through door switch LH terminal **②**
- from door switch LH terminal **③**
- through body grounds **M14** and **M68**.

When the door switch RH is OPEN, ground is supplied:

- to smart entrance control unit terminal **35**
- through door switch RH terminal **①**
- through door switch body ground.

When the door lock actuator LH (door unlock sensor) is UNLOCKED, ground is supplied:

- to smart entrance control unit terminal **12**
- through door lock actuator LH (door unlock sensor) terminal **②**
- to door lock actuator LH (door unlock sensor) terminal **④**
- through body grounds **M14** and **M68**.

When the door lock actuator RH (door unlock sensor) is UNLOCKED, ground is supplied to smart entrance control unit terminal **13** in the same manner as door lock actuator LH.

Remote controller signal input:

- through internal antenna.

The multi-remote control system controls operation of the

- power door lock
- interior lamp
- panic alarm
- hazard reminder.

OPERATION PROCEDURE

Power door lock operation

When the following input signals are both supplied:

- key switch REMOVED (when ignition key is not inserted in key cylinder);
- door switch CLOSED (when all the doors are closed).

MULTI-REMOTE CONTROL SYSTEM

System Description (Cont'd)

The above two signals are already input into the smart entrance control unit. At this point, smart entrance control unit receives a LOCK signal from the remote controller. The smart entrance control unit locks all doors with input of the LOCK signal from the remote controller.

And then ground is supplied:

- to multi-remote control relay terminal ①
- through smart entrance control unit terminal ⑦.

Multi-remote control relay is now energized, and the hazard warning lamps flash twice as a reminder—**HAZARD REMINDER**. For detailed description, refer to "TURN SIGNAL AND HAZARD WARNING LAMPS", EL-64.

When an UNLOCK signal is sent from the remote controller once, the driver's door will be unlocked.

Then, if an UNLOCK signal is sent from the remote controller again within 5 seconds, the passenger door will be unlocked.

To deactivate the horn chirp when using the remote controller, press both unlock and lock buttons for two seconds. With the horn deactivated, the exterior lights do not flash when the unlock button is pressed. To activate the horn chirp, press both unlock and lock buttons for two seconds.

Interior lamp operation

When the following input signals are both supplied:

- key switch REMOVED (when ignition key is not inserted in key cylinder);
- door switch CLOSED (when all the doors are closed);

multi-remote control system turns on interior lamp (for 30 seconds) with input of UNLOCK signal from remote controller.

For detailed description, refer to "INTERIOR ROOM LAMP", EL-72.

Panic alarm operation

When key switch is OFF (when ignition key is not inserted in key cylinder), multi-remote control system turns on and off horn and headlamps intermittently with input of PANIC ALARM signal from remote controller.

For detailed description, refer to "THEFT WARNING SYSTEM", EL-189.

MULTI-REMOTE CONTROL SYSTEM

Schematic

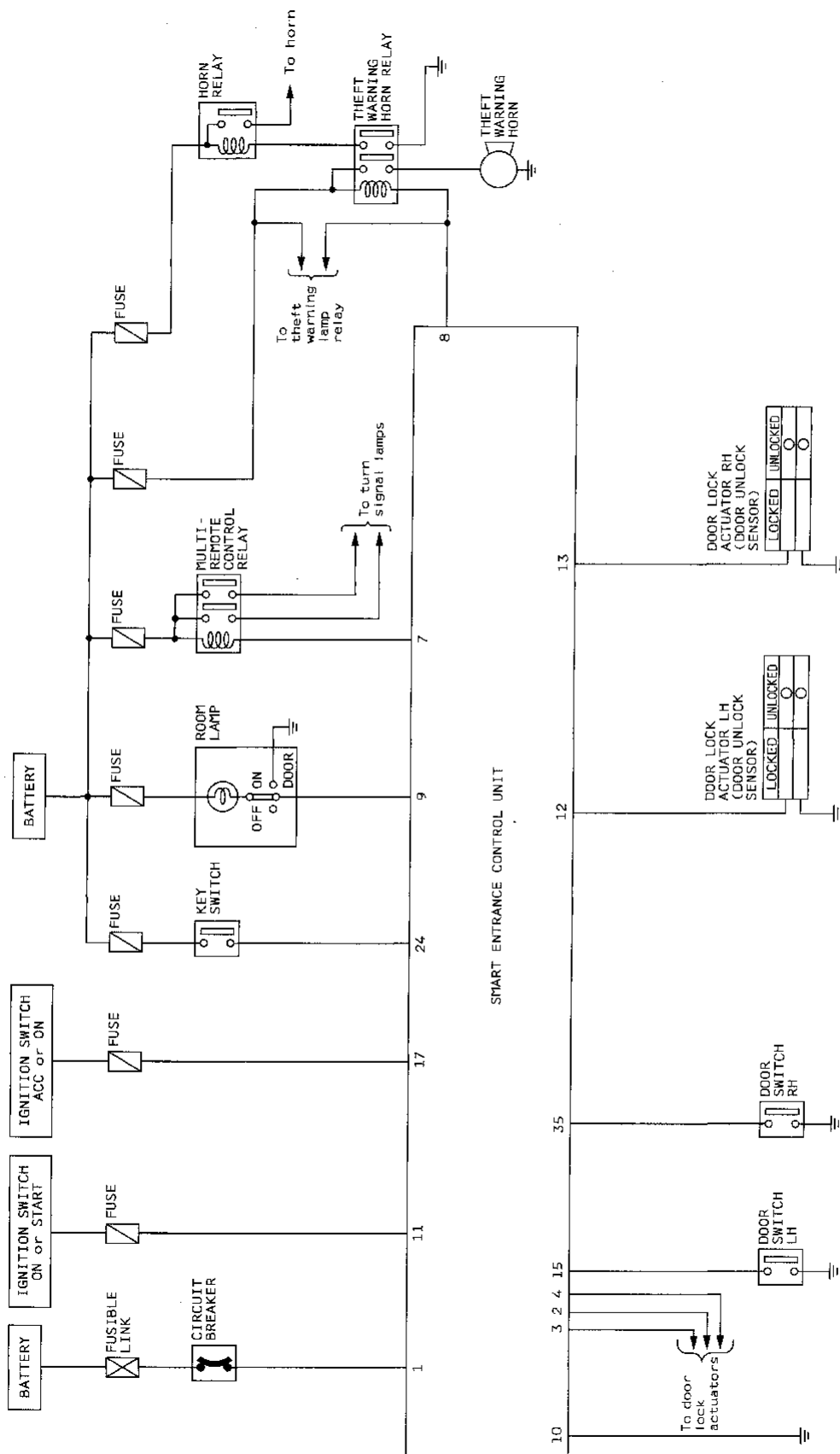

GI

MA

EM

LC

EC

FE

CL

MT

AT

TF

PD

FA

RA

BR

ST

RS

BT

HA

EL

IDX

MULTI-REMOTE CONTROL SYSTEM

Wiring Diagram — MULTI —

EL-MULTI-01

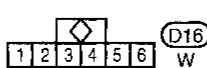
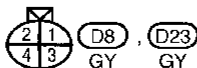
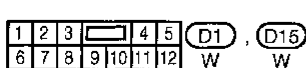
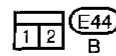
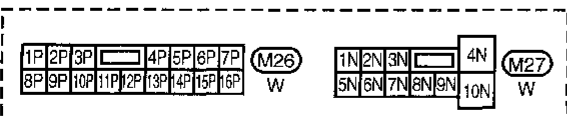
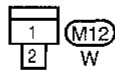
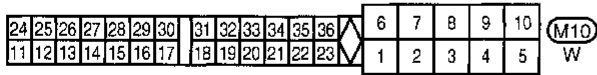
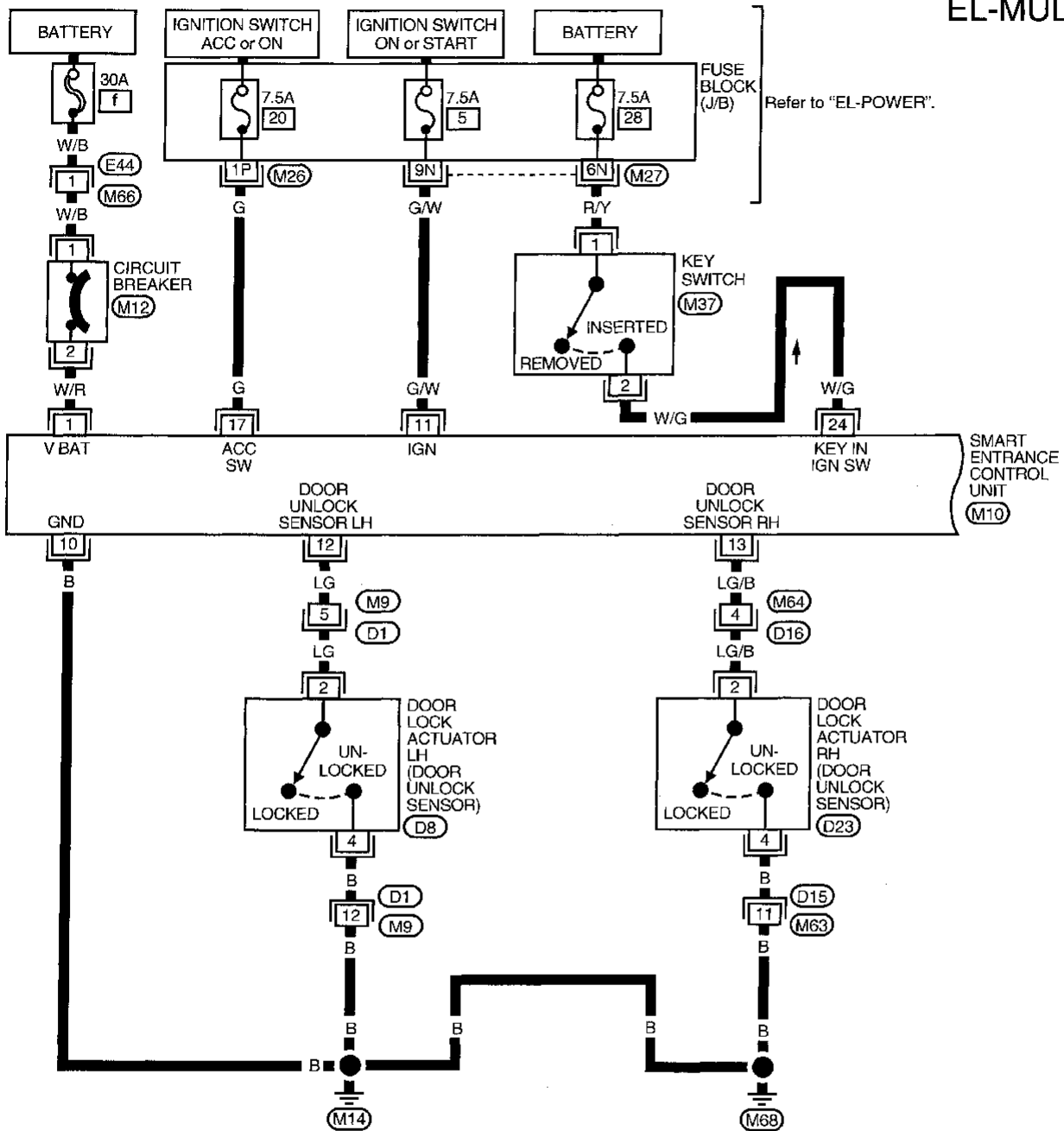

MULTI-REMOTE CONTROL SYSTEM

Wiring Diagram — MULTI — (Cont'd)

EL-MULTI-02

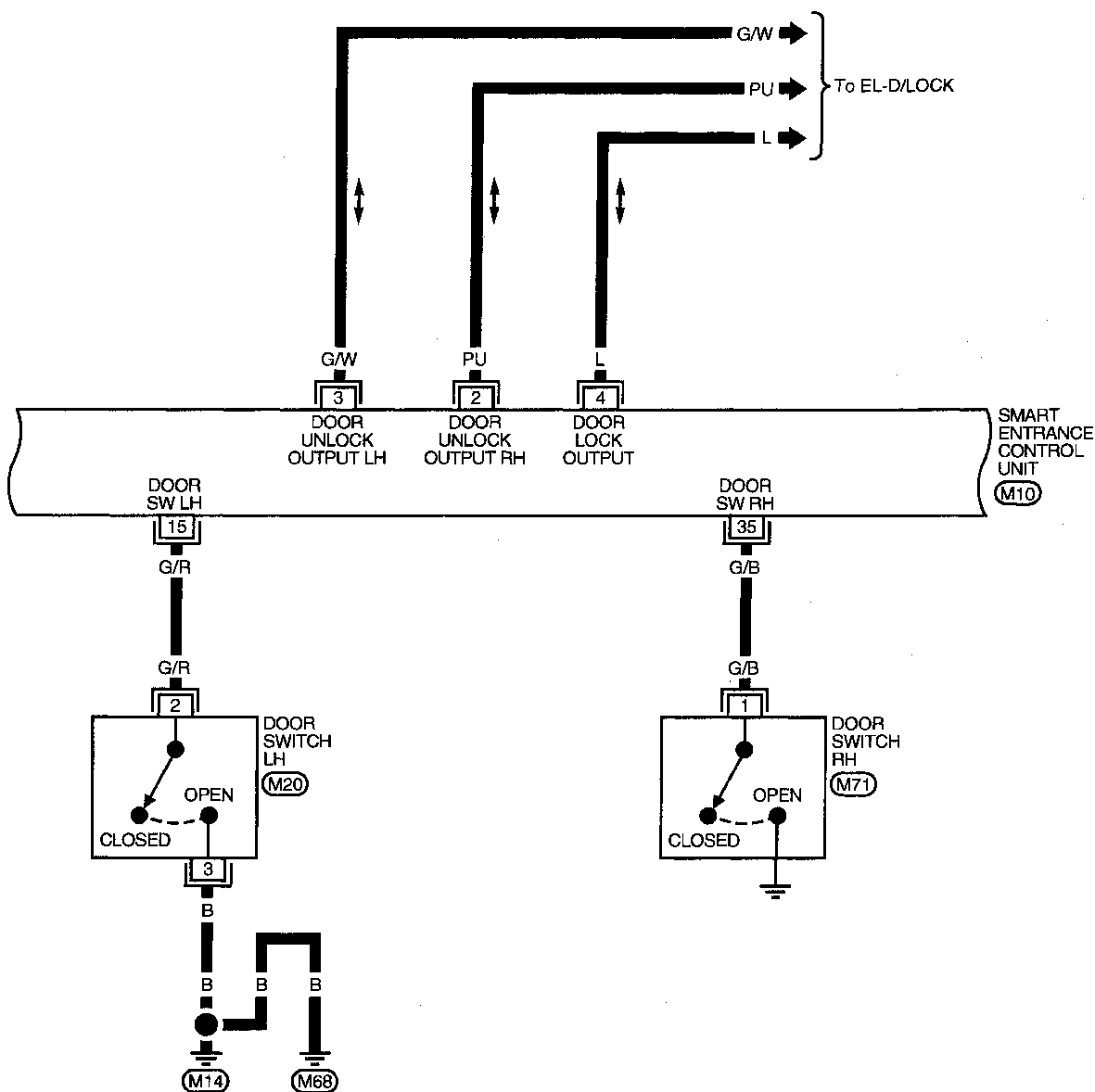

24	25	26	27	28	29	30	31	32	33	34	35	36	6	7	8	9	10	(M10)
11	12	13	14	15	16	17	18	19	20	21	22	23	1	2	3	4	5	W



MULTI-REMOTE CONTROL SYSTEM

Wiring Diagram — MULTI — (Cont'd)

EL-MULTI-03

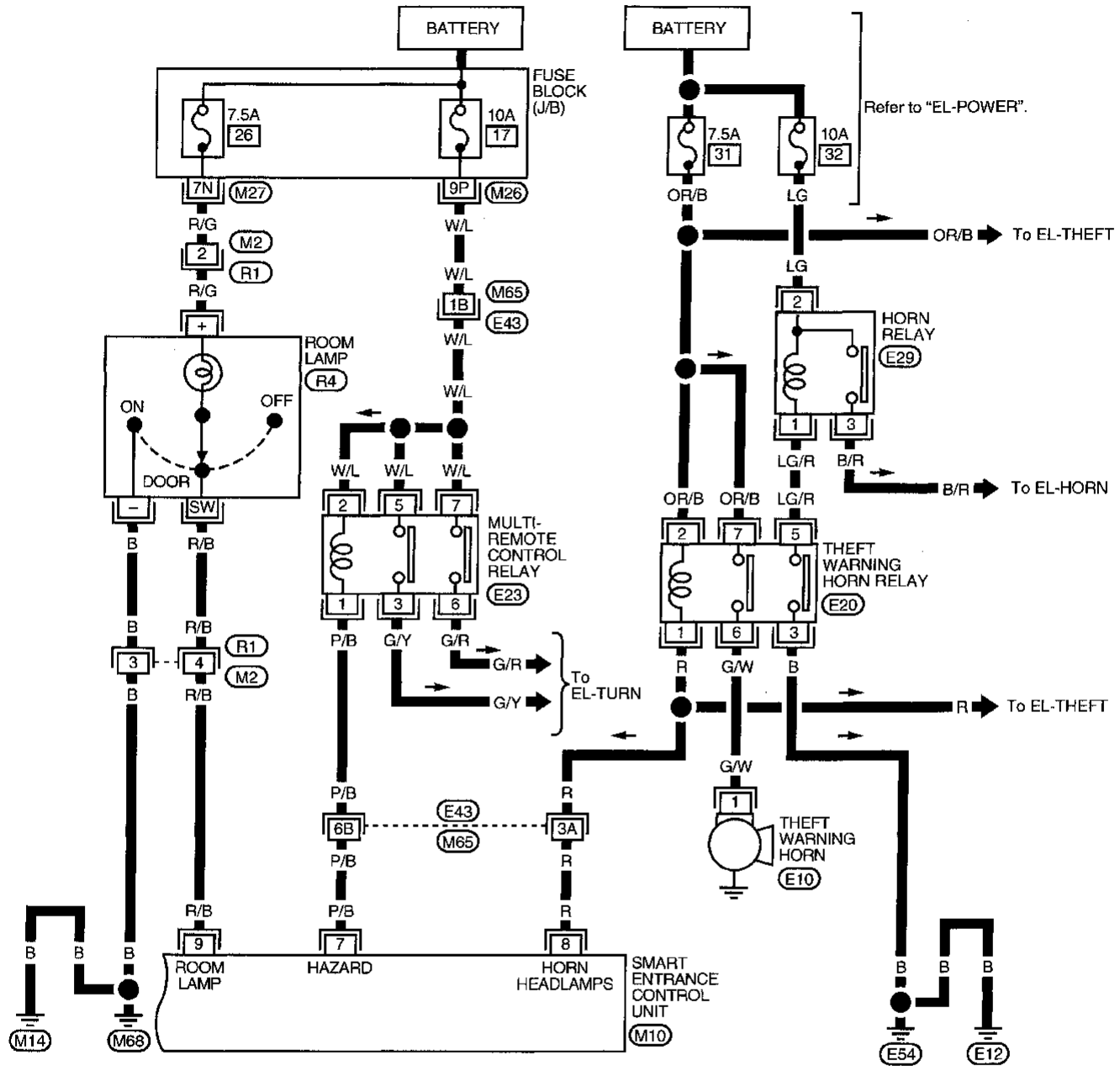

Refer to last page (Foldout page).

(M65), (E43)

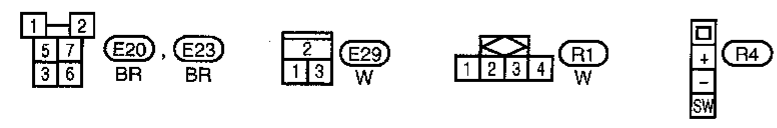
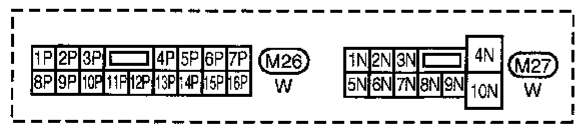
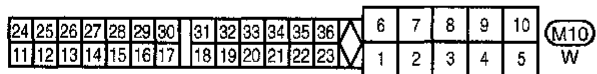

MULTI-REMOTE CONTROL SYSTEM

Trouble Diagnoses

TROUBLE SYMPTOM

- All functions of remote control system do not operate.

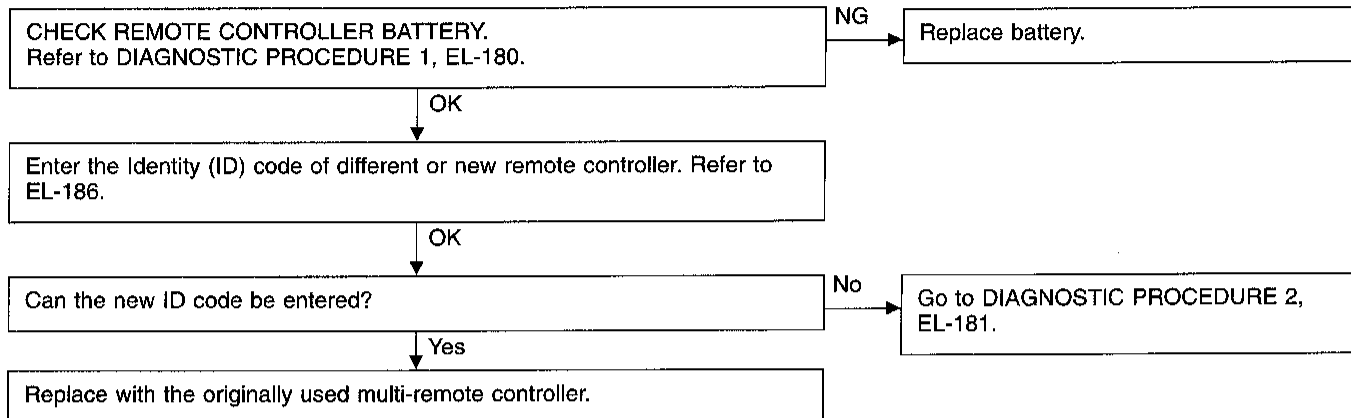

- Some functions of multi-remote controller do not operate.

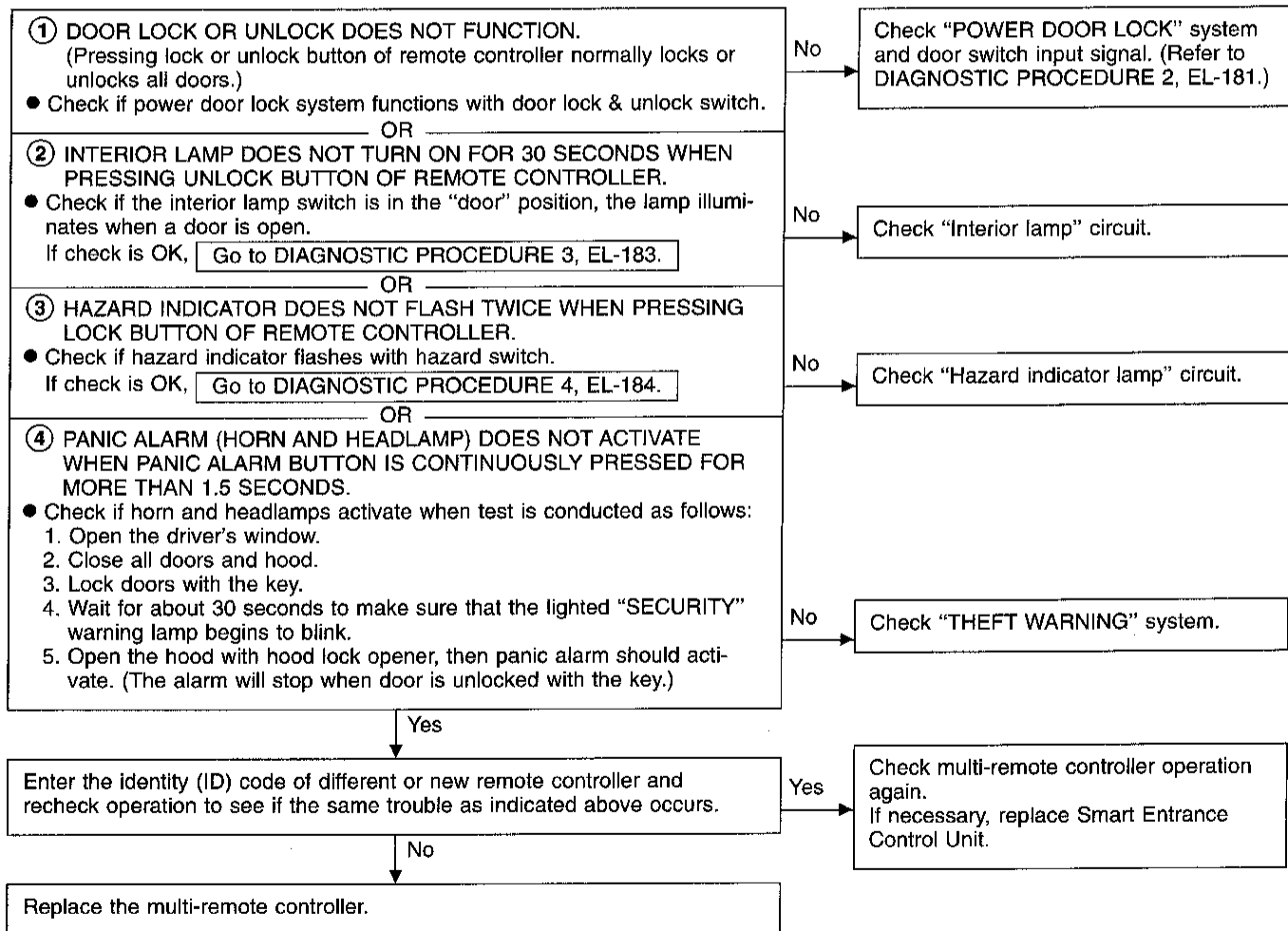

- Note:**
- The unlock and panic alarm operation of the multi-remote control system does not activate with the ignition key inserted in the ignition key cylinder.
 - The lock operation of the multi-remote control system does not activate with the key inserted in the ignition key cylinder or if one of the doors is opened.

MULTI-REMOTE CONTROL SYSTEM

Trouble Diagnoses (Cont'd)

DIAGNOSTIC PROCEDURE 1

Check remote controller battery.

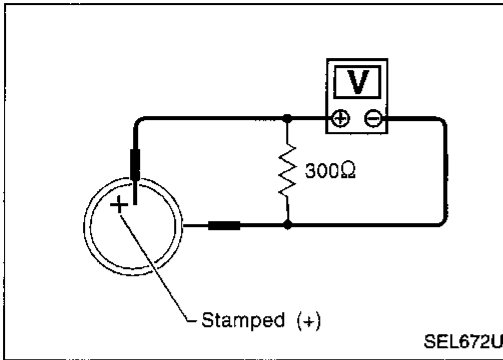

CHECK REMOTE CONTROLLER BATTERY.

Remove battery and measure voltage across battery positive and negative terminals, ⊕ and ⊖.

Measuring terminal		Standard value
⊕	⊖	
Battery positive terminal ⊕	Battery negative terminal ⊖	2.5 - 3.0V

Note:

Remote controller does not function if battery is not set correctly.

MULTI-REMOTE CONTROL SYSTEM

Trouble Diagnoses (Cont'd)

DIAGNOSTIC PROCEDURE 2

All remote controls do not function even if remote controller is operated properly.

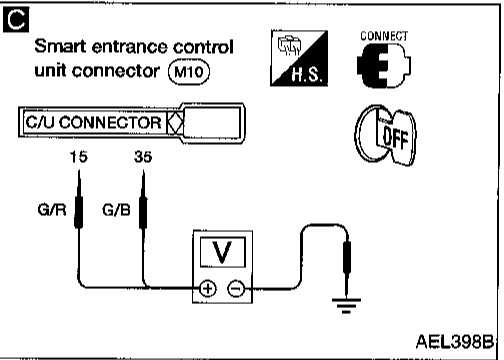
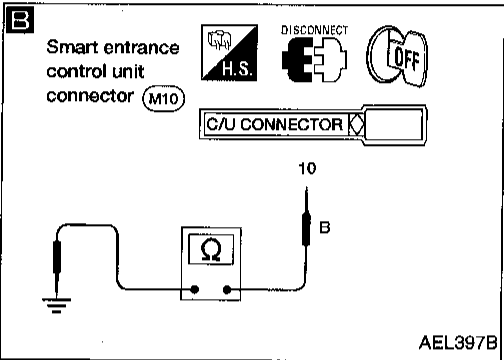
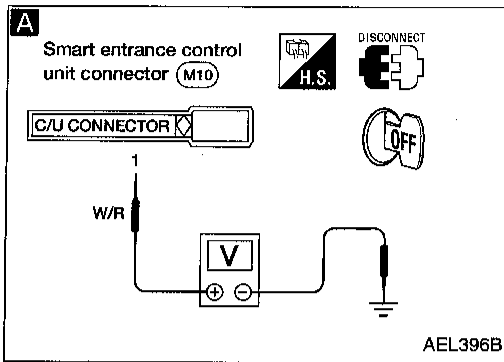

A

CHECK MAIN POWER SUPPLY CIRCUIT FOR CONTROL UNIT.

1. Disconnect connector from control unit.
2. Check voltage between control unit terminal ① and ground.

Battery voltage should exist.

Refer to wiring diagram in EL-176.

NG

Check the following:

- 30A fusible link (Letter **f**), located in fuse and fusible link box)
- (M12) circuit breaker
- Harness for open or short between control unit and fusible link

B

CHECK GROUND CIRCUIT FOR CONTROL UNIT.

Check continuity between terminal ⑩ and ground.

Continuity should exist.

Refer to wiring diagram in EL-176.

NG

Check ground harness.

C

CHECK DOOR SWITCH CIRCUIT.

1. Connect control unit connector.
2. Check voltage between control unit terminal ⑮ and ground and ⑳ and ground.

	Terminals		Condition	Voltage [V]
	⊕	⊖		
Driver side door switch	⑮	Ground	Open	0
			Close	Approx. 12
Passenger door switch	⑳	Ground	Open	0
			Close	Approx. 12

Refer to wiring diagram in EL-177.

NG

Check the following.

- Door switch
- Door switch ground condition
- Harness for open or short between control unit and door switch

OK

A

(Go to next page.)

GI
MA
EM
LC
EC
FE
CL
MT
AT
TF
PD
FA
RA
BR
ST
RS
BT
HA
EL
IDX

MULTI-REMOTE CONTROL SYSTEM

Trouble Diagnoses (Cont'd)

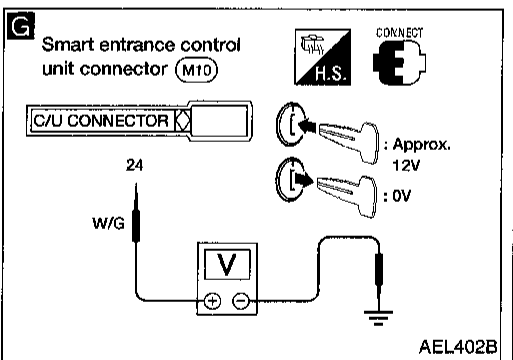
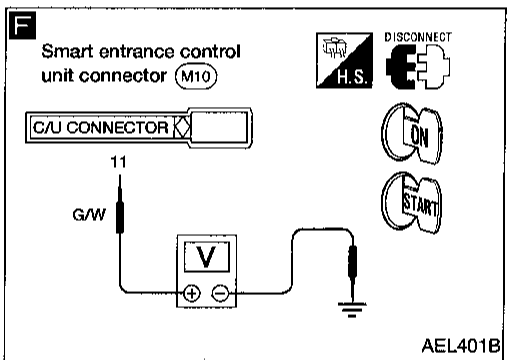
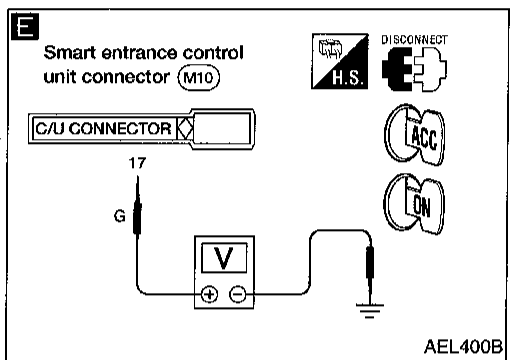
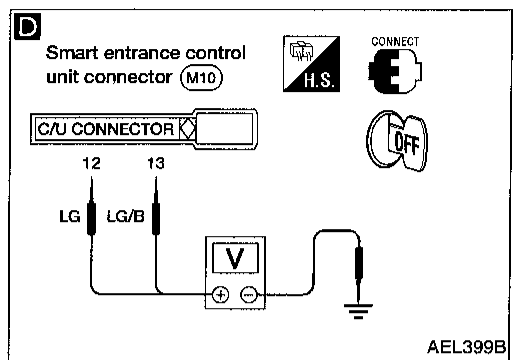

D

CHECK UNLOCK SENSOR CIRCUIT.
Check voltage between control unit terminal ⑫ and ground and ⑬ and ground.

	Terminals		Condition	Voltage [V]
	⊕	⊖		
LH door	⑫	Ground	Unlock	0
			Lock	Approx. 12
RH door	⑬	Ground	Unlock	0
			Lock	Approx. 12

Refer to wiring diagram in EL-176.

- NG
- Check the following:
- Door unlock sensor
 - Refer to "Electrical Components Inspection", EL-185.
 - Door unlock sensor ground circuit
 - Harness for open or short between control unit and unlock sensor

E

CHECK IGNITION SWITCH ACC OR ON CIRCUIT.

1. Disconnect control unit connector.
2. Check voltage between control unit terminal ⑰ and ground while ignition switch is in ACC or ON position. **Battery voltage should exist.**

Refer to wiring diagram in EL-176.

- NG
- Check the following:
- 7.5A fuse [No. ⑳], located in fuse block (J/B)
 - Harness for open or short between control unit and fuse

F

CHECK IGNITION SWITCH ON OR START CIRCUIT.
Check voltage between control unit terminal ⑪ and ground while ignition switch is in ON or START position. **Battery voltage should exist.**

Refer to wiring diagram in EL-176.

- NG
- Check the following:
- 7.5A fuse [No. ⑤], located in fuse block (J/B)
 - Harness for open or short between control unit and fuse

G

CHECK KEY SWITCH INPUT SIGNAL.

1. Connect control unit connector.
2. Check voltage between control unit terminal ⑳ and ground.

Condition	Voltage [V]
Key is inserted.	Approx. 12
Key is withdrawn.	0

Refer to wiring diagram in EL-176.

- NG
- Check the following:
- 7.5A fuse [No. ⑳], located in fuse block (J/B)
 - Key switch
 - Refer to "Electrical Components Inspection", EL-185.
 - Harness for open or short between key switch and fuse
 - Harness for open or short between control unit and key switch

OK

Check operation parts in multi-remote control system for function.

MULTI-REMOTE CONTROL SYSTEM

Trouble Diagnoses (Cont'd)

DIAGNOSTIC PROCEDURE 3

Interior lamp does not turn on for 30 seconds when pressing unlock button of remote controller. Everything else functions.

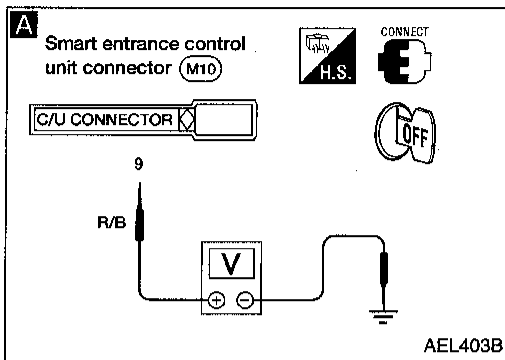

A

CHECK INTERIOR LAMP CIRCUIT.
When interior lamp switch is in DOOR position, check voltage between control unit terminal ⑨ and ground.
Does battery voltage exist?

Refer to wiring diagram in EL-178.

No

Repair harness between control unit and interior lamp.

Yes

A

Push unlock button of remote controller and check voltage between control unit terminal ⑨ and ground.

Multi-remote controller button condition	Voltage (V)
Unlock button is pushed.	0
Unlock button is not pushed.	Battery voltage

No

Check harness for open or short between interior lamp and control unit.

Yes

Check system again.

GI

MA

EM

LC

EC

FE

CL

MT

AT

TF

PD

FA

RA

BR

ST

RS

BT

HA

EL

IDX

MULTI-REMOTE CONTROL SYSTEM

Trouble Diagnoses (Cont'd)

DIAGNOSTIC PROCEDURE 4

Hazard indicator does not flash twice when pressing lock button of remote controller. Everything else functions.

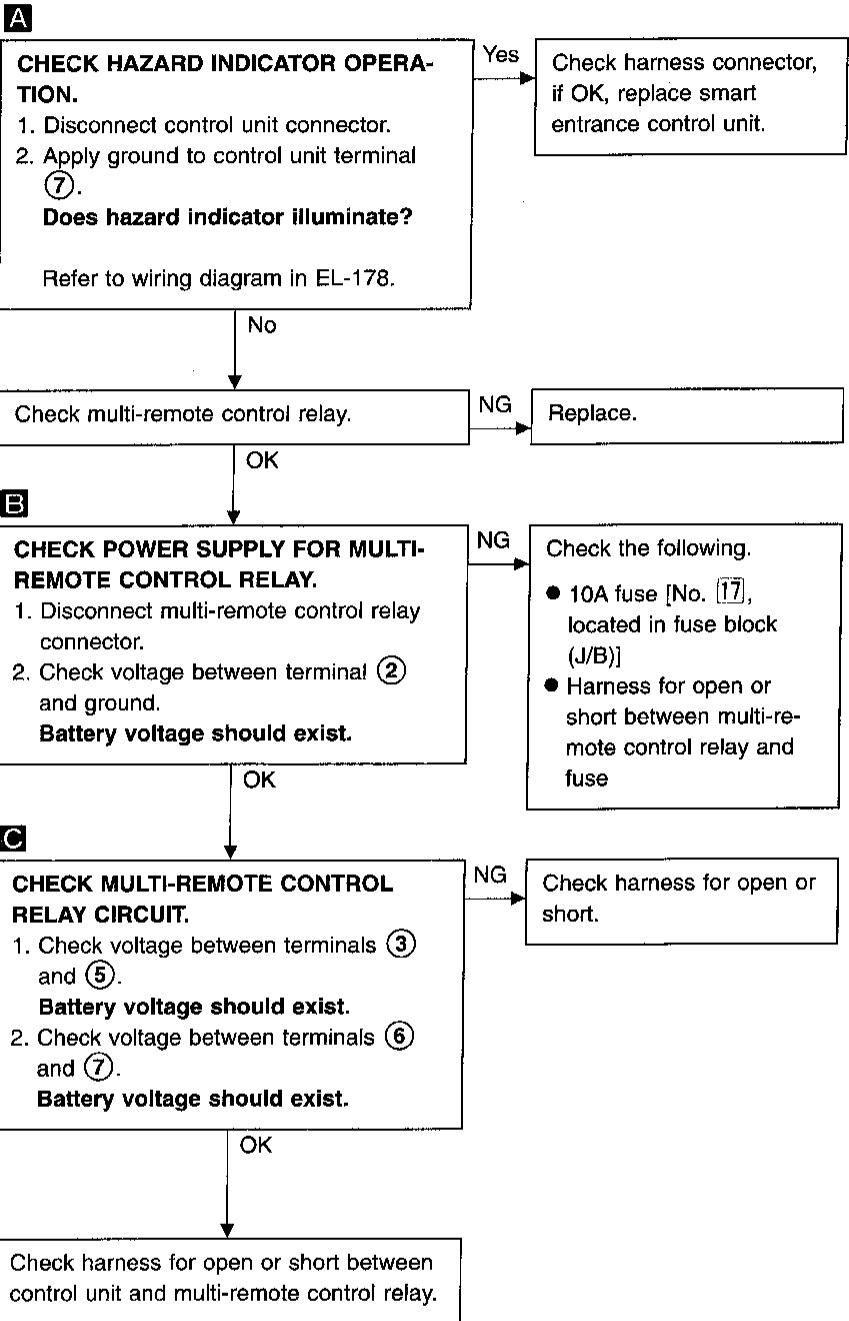
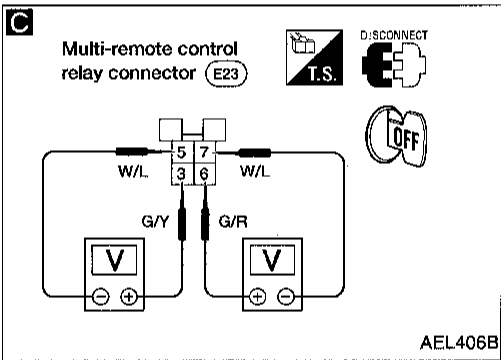
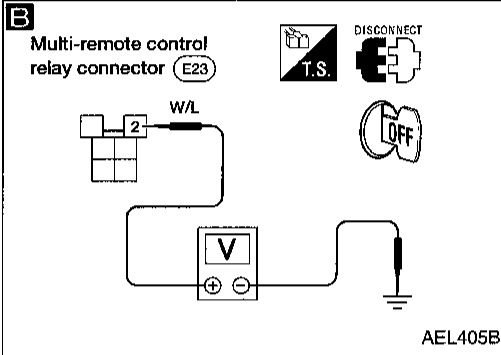
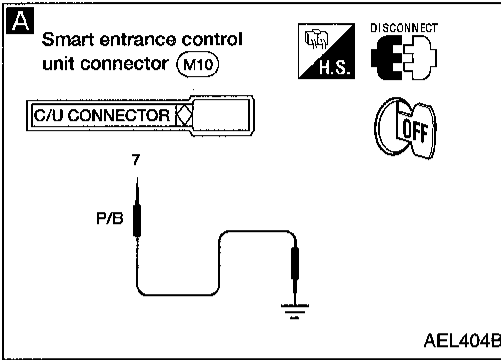

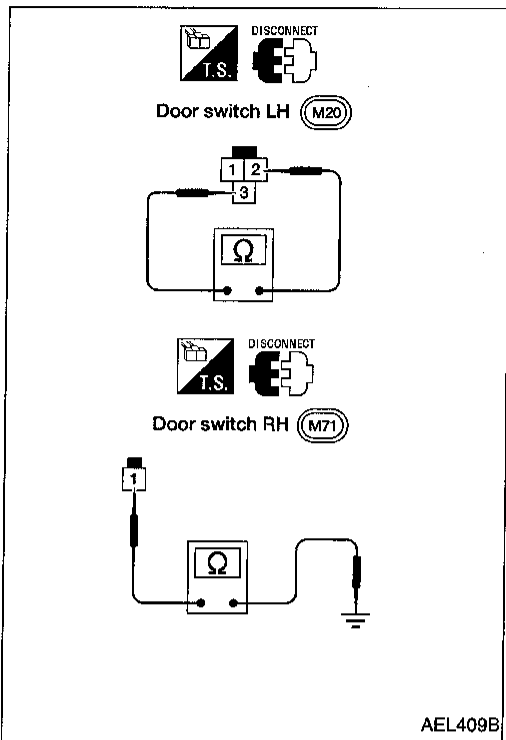

Electrical Components Inspection

DOOR SWITCHES

Check continuity between terminals when door switch is pushed and released.

	Terminal No.	Condition	Continuity
Door switch LH	② - ③	Door switch is pushed.	No
		Door switch is released.	Yes
Door switch RH	① - Ground	Door switch is pushed.	No
		Door switch is released.	Yes

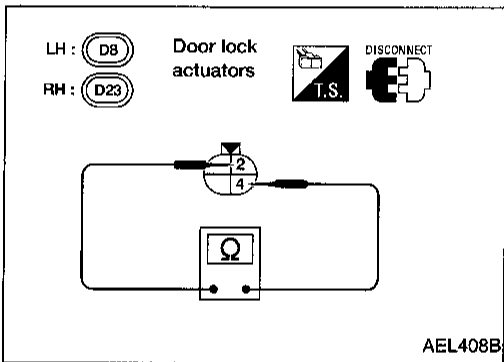

DOOR LOCK ACTUATOR (Door unlock sensor)

Check continuity between terminals when door is locked and unlocked.

Terminal No.	Condition	Continuity
④ - ②	Door is locked.	No
	Door is unlocked.	Yes

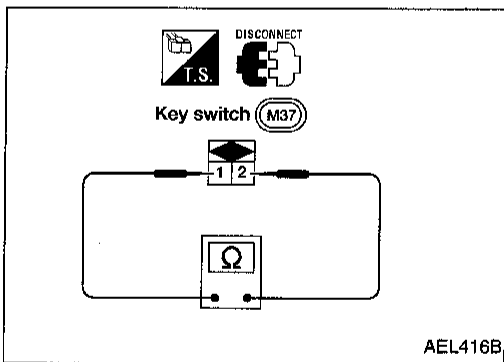

KEY SWITCH (insert)

Check continuity between terminals when key is inserted in ignition key cylinder and key is removed from ignition key cylinder.

Terminal No.	Condition	Continuity
① - ②	Key is inserted.	Yes
	Key is removed.	No

MULTI-REMOTE CONTROL SYSTEM

ID Code Entry Procedure

Enter the identity (ID) code manually when:

- remote controller or control unit is replaced.
- an additional remote controller is activated.

To enter the ID code, follow the procedure below.

PROCEDURE

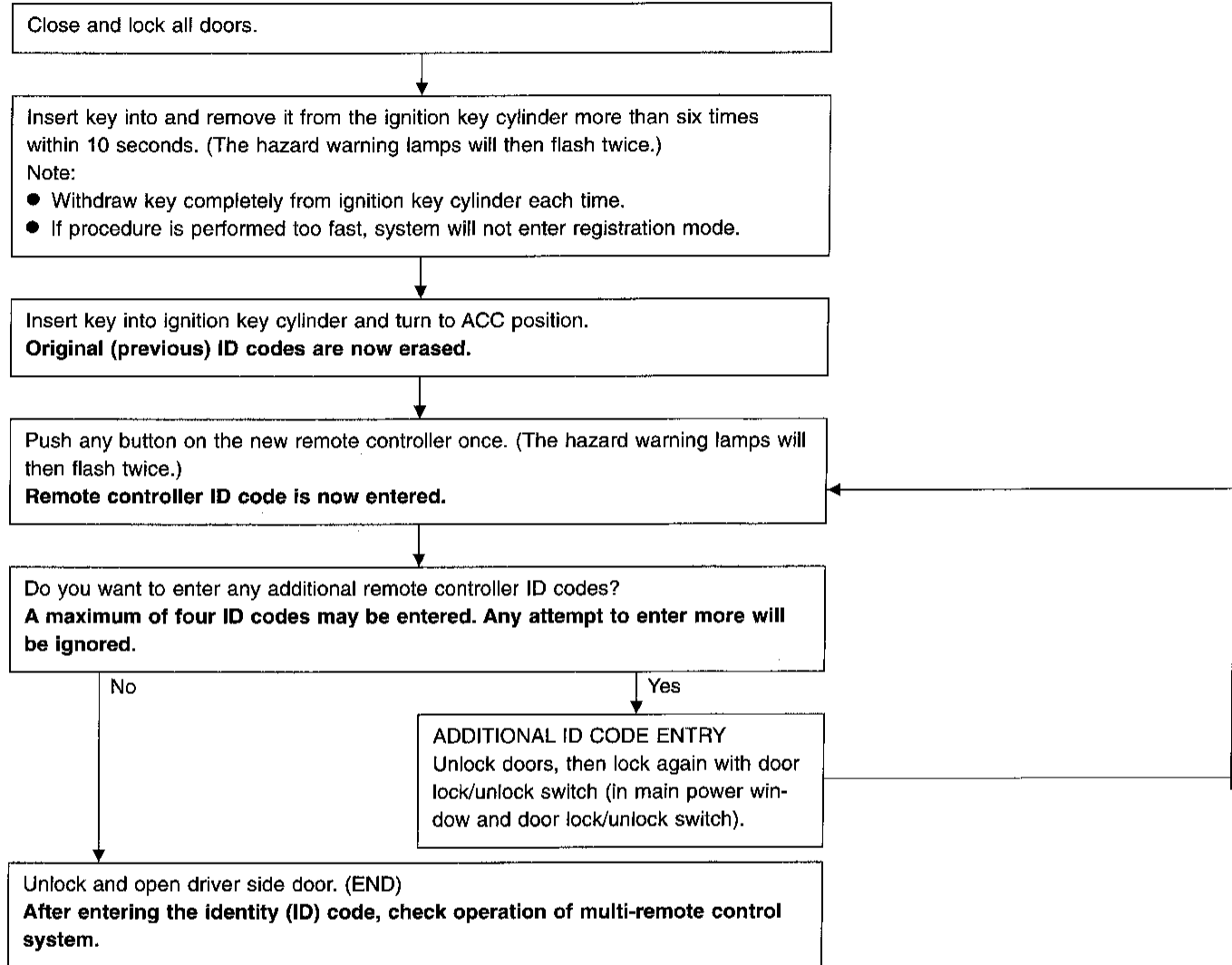

NOTE:

- If you need to activate more than two additional new remote controllers, repeat the procedure "Additional ID code entry" for each new remote controller.
- If the same ID code that exists in the memory is input, the entry will be ignored.
- Entry of four ID codes maximum is allowed and any attempt to enter more will be ignored.
- Any ID codes entered after termination of the "setting mode" will not be accepted. Additional remote control signals will be inhibited if not entered during the "setting" mode.

THEFT WARNING SYSTEM

Component Parts and Harness Connector Location

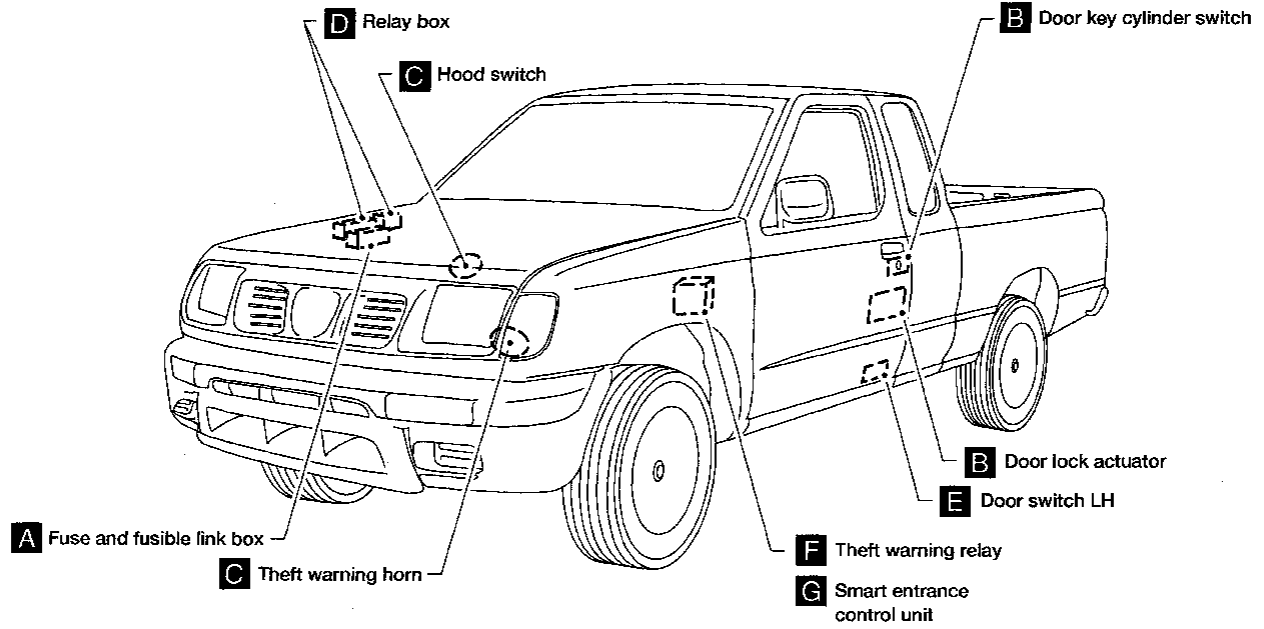

GI

MA

EM

LC

EC

FE

CL

MT

AT

TF

PD

FA

RA

BR

ST

RS

BT

HA

EL

IDX

THEFT WARNING SYSTEM

Component Parts and Harness Connector Location (Cont'd)

Fuse block (J/B)

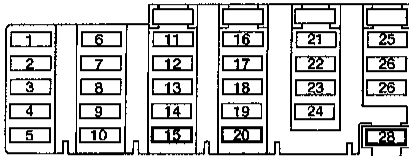

A Fuse and fusible link box

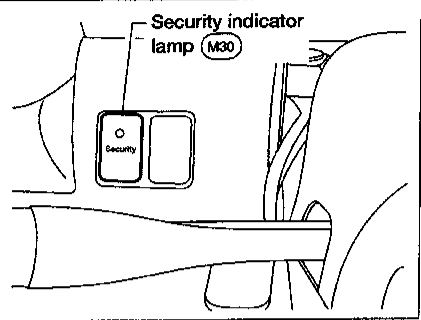
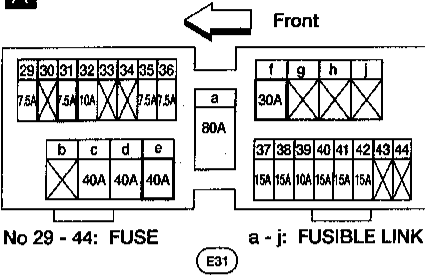

B View with door trim panel removed

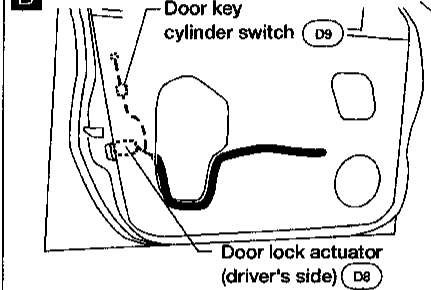

C Hood switch (E9)
Theft warning horn (E10)

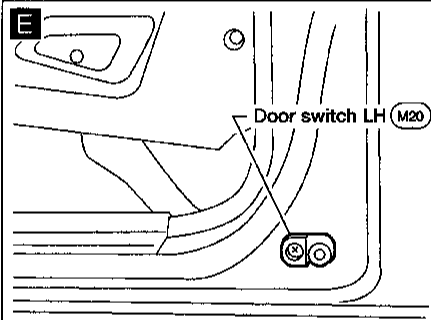
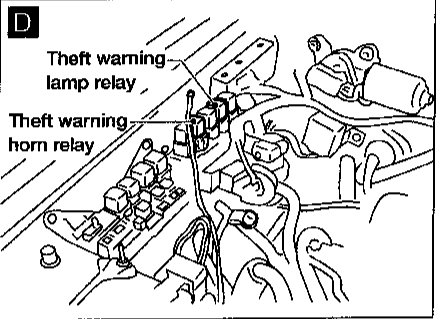
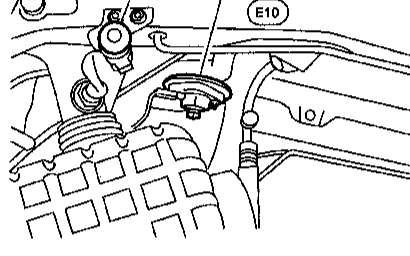

F View with instrument lower panel driver's side removed

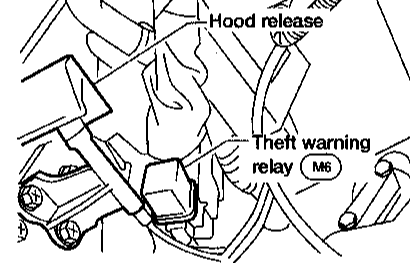

G View with instrument lower panel driver's side removed

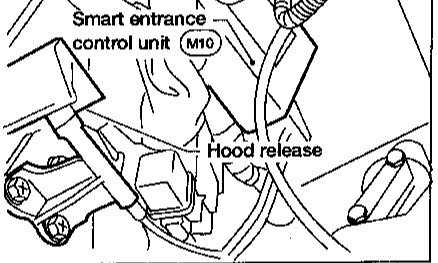

THEFT WARNING SYSTEM

System Description

OPERATION FLOW

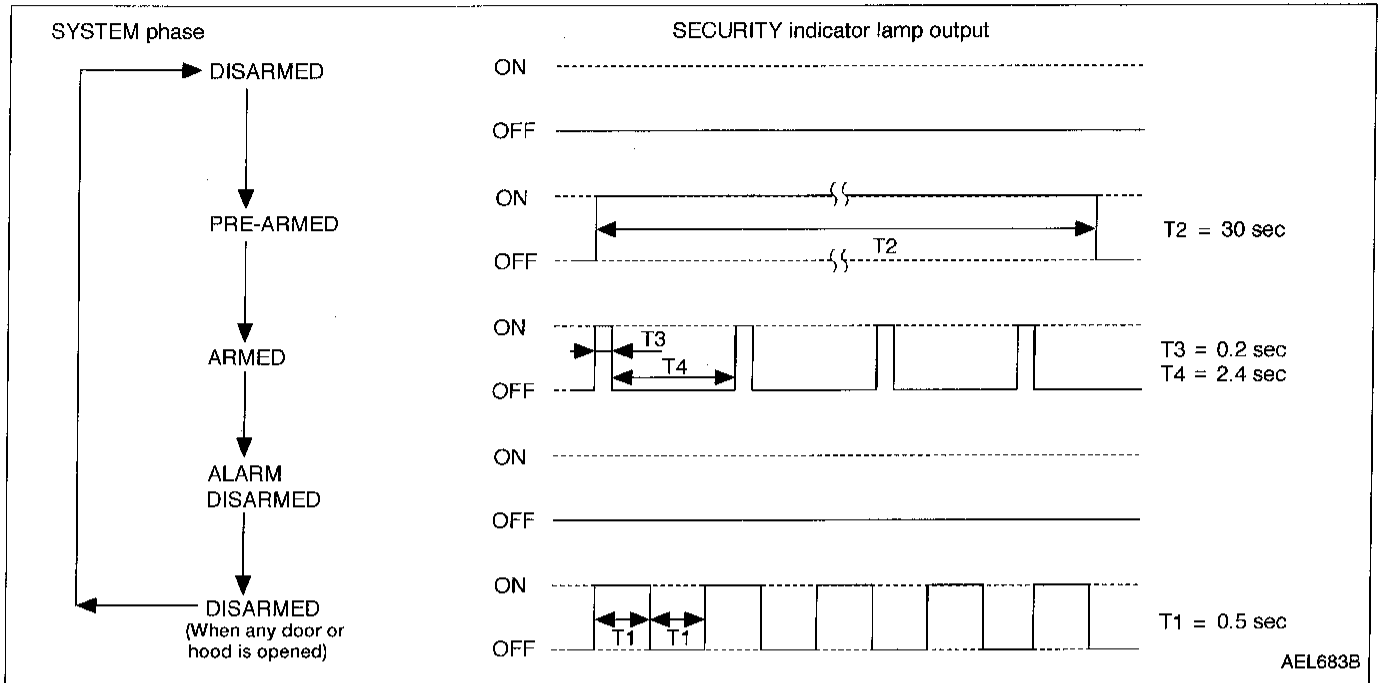

SETTING THE THEFT WARNING SYSTEM

Initial condition

- (1) Close all doors.
- (2) Close hood.

Disarmed phase

The theft warning system is in the disarmed phase when any door(s) or hood is opened. The security indicator lamp blinks every second.

Pre-armed phase and armed phase

The theft warning system turns into the "pre-armed" phase when hood and all doors are closed and locked by key or multi-remote controller. (The security indicator lamp illuminates.) After about 30 seconds, the system automatically shifts into the "armed" phase (the system is set). (The security indicator lamp blinks every 2.6 seconds.)

CANCELING THE SET THEFT WARNING SYSTEM

When the following operation is performed, the armed phase is canceled. Unlock the doors with the key or multi-remote controller.

ACTIVATING THE ALARM OPERATION OF THE THEFT WARNING SYSTEM

Make sure the system is in the armed phase. (The security indicator lamp blinks every 2.6 seconds.)

When the following operation (a) or (b) is performed, the system sounds the horns and flashes the headlamps for about 2.5 minutes. (At the same time, the system disconnects the starting system circuit.)

- (a) Engine hood or any door is opened before unlocking door with key or multi remote controller.
- (b) Door is unlocked without using key or multi-remote controller.

THEFT WARNING SYSTEM

System Description (Cont'd)

POWER SUPPLY AND GROUND CIRCUIT

Power is supplied at all times:

- through 7.5A fuse [No. 28], located in the fuse block (J/B)]
- to security indicator lamp terminal ① and
- to key switch terminal ①.

When the key switch is INSERTED (ignition key is inserted in key cylinder), power is supplied:

- through key switch terminal ②
- to smart entrance control unit terminal ⑳.

Power is supplied at all times:

- through 30A fusible link (letter F), located in the fuse and fusible link box)
- to circuit breaker terminal ①
- through circuit breaker terminal ②
- to smart entrance control unit terminal ①.

With the ignition switch in the ACC or ON position, power is supplied:

- through 7.5A fuse [No. 20], located in the fuse block (J/B)]
- to smart entrance control unit terminal ⑰.

With the ignition switch in the ON or START position, power is supplied:

- through 7.5A fuse [No. 5], located in the fuse block (J/B)]
- to smart entrance control unit terminal ①①.

Ground is supplied:

- through body grounds M14 and M68
- to smart entrance control unit terminal ⑩.

INITIAL CONDITION TO ACTIVATE THE SYSTEM

The operation of the theft warning system is controlled by the doors and hood.

To activate the theft warning system, the smart entrance control unit must receive signals indicating the doors and hood are closed and the doors are locked.

When a door is open, smart entrance control unit terminals ⑮ or ⑳ receives a ground signal from each door switch.

When a door is unlocked, smart entrance control unit terminals ⑫ or ⑬ receives a ground signal:

- from terminal ② of each door unlock sensor
- through terminal ④ of each door unlock sensor
- through body grounds M14 and M68 for the door unlock sensors LH or RH.

When the hood is open, smart entrance control unit terminal ㉑ receives a ground signal:

- from terminal ⊕ of the hood switch
- through terminal ⊖ of the hood switch
- through body grounds E12 and E54.

When the doors are locked using the key or multi-remote controller and none of the described conditions exist, the theft warning system will automatically shift to the armed phase.

THEFT WARNING SYSTEM ACTIVATION (With key or remote controller used to lock doors)

If the key is used to lock doors, smart entrance control unit terminal ㉓ receives a ground signal:

- from terminal ① of the door key cylinder switch LH
- from terminal ③ of the door key cylinder switch RH
- through terminal ② of the front door key cylinder switch LH or RH
- through body grounds M14 and M68.

If this signal or lock signal from remote controller is received by the smart entrance control unit, the theft warning system will activate automatically.

Once the theft warning system has been activated, smart entrance control unit terminal ㉔ supplies ground to terminal ② of the security indicator lamp.

The security lamp will illuminate for approximately 30 seconds and then blink every 2.6 seconds.

Now the theft warning system is in armed phase.

THEFT WARNING SYSTEM ALARM OPERATION

The theft warning system is triggered by:

- opening a door
- opening the hood
- unlocking door without using the key or multi-remote controller.

Once the theft warning system is in armed phase, if the smart entrance control unit receives a ground signal

THEFT WARNING SYSTEM

System Description (Cont'd)

at terminal ⑫, ⑬ (door unlock sensor), ⑮, ⑯ (door switch) or ⑲ (hood switch), the theft warning system will be triggered. The headlamps flash and the horns sound intermittently, and the starting system is interrupted.

With the ignition switch in the ON or START position, power is supplied:

- through 7.5A fuse [No. ⑤], located in the fuse block (J/B).
- to theft warning relay terminal ②.

If the theft warning system is triggered, ground is supplied:

- from terminal ⑳ of the smart entrance control unit
- to theft warning relay terminal ①.

With power and ground supplied, ground to the clutch interlock relay (M/T models) or park/neutral position (PNP) relay (A/T models) is interrupted. The starter motor will not crank and the engine will not start, refer to EL-START (EL-26).

Power is supplied at all times:

- through 7.5A fuse (No. ⑩), located in fuse and fusible link box
- to theft warning lamp relay terminal ② and
- to theft warning horn relay terminals ② and ⑦.

When the theft warning system is triggered, ground is supplied intermittently:

- from terminal ⑧ of the smart entrance control unit
- to theft warning lamp relay terminal ① and
- to theft warning horn relay terminal ①.

The headlamps flash and the horns sound intermittently.

The alarm automatically turns off after 2 or 3 minutes but will reactivate if the vehicle is tampered with again.

THEFT WARNING SYSTEM DEACTIVATION

To deactivate the theft warning system a door must be unlocked with the key or remote controller.

When the key is used to unlock a door, smart entrance control unit terminal ⑳ receives a ground signal:

- from terminal ③ of the door key cylinder switch LH
- from terminal ① of the door key cylinder switch RH
- through terminal ② of the front door key cylinder switch LH or RH
- through body grounds ①④ and ①⑥.

When the smart entrance control unit receives this signal or unlock signal from remote controller, the theft warning system is deactivated. (Disarmed phase)

PANIC ALARM OPERATION

Multi-remote control system may or may not operate theft warning system (horn and headlamps) as required.

When the multi-remote control system is triggered, ground is supplied intermittently:

- from smart entrance control unit terminal ⑧
- to theft warning lamp relay terminal ① and
- to theft warning horn relay terminal ①.

The headlamps flash and the horns sound intermittently.

The alarm automatically turns off after 30 seconds or when smart entrance control unit receives any signal from multi-remote controller.

GI

MA

EM

LC

EC

FE

CL

MT

AT

TF

PD

FA

RA

BR

ST

RS

BT

HA

EL

IDX

THEFT WARNING SYSTEM

Schematic

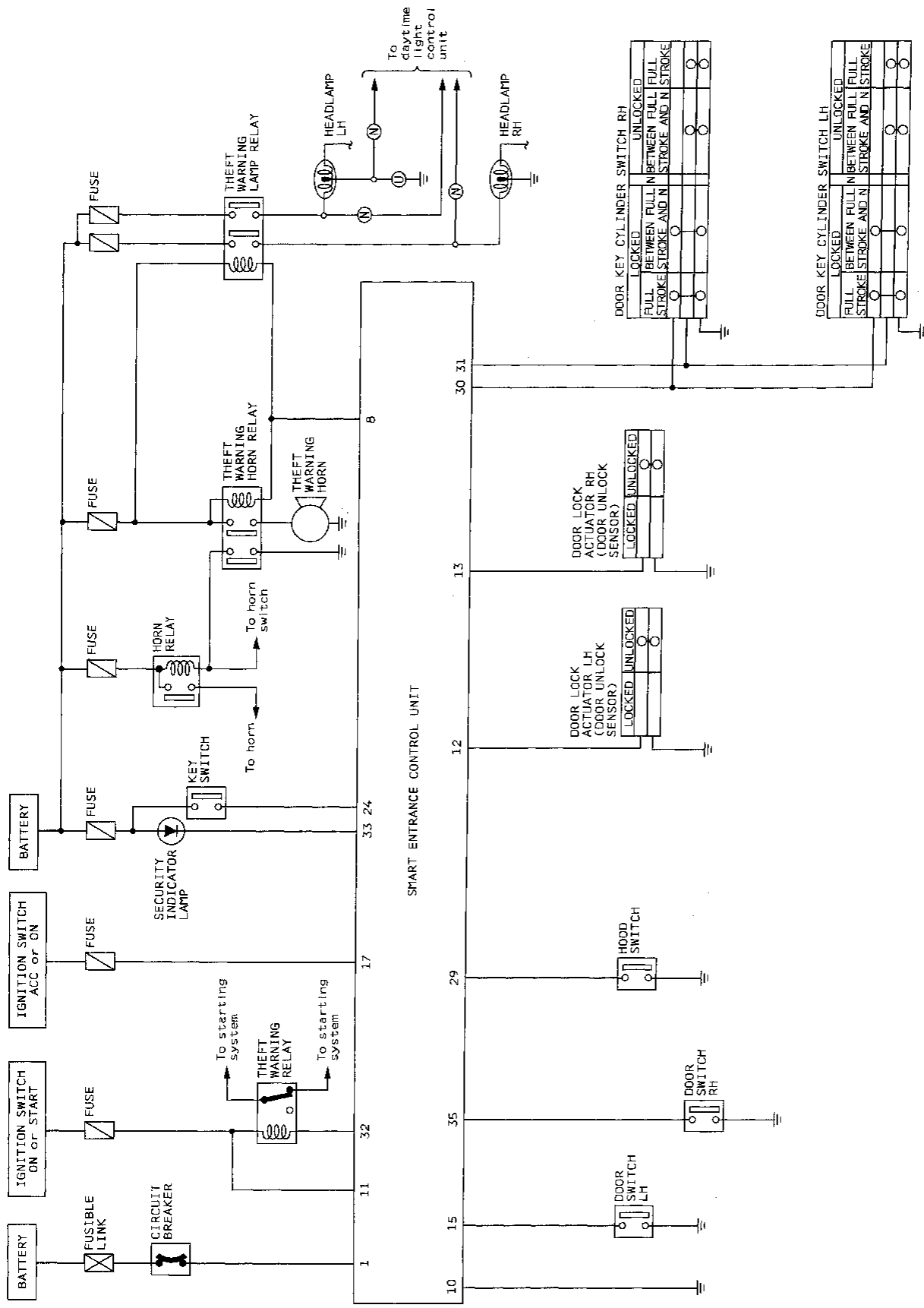

Ⓜ : For USA
 Ⓝ : For Canada

THEFT WARNING SYSTEM

Wiring Diagram — THEFT —

EL-THEFT-01

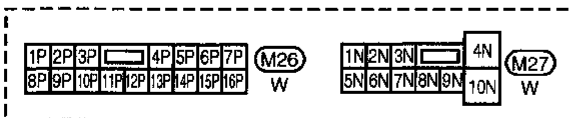
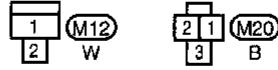
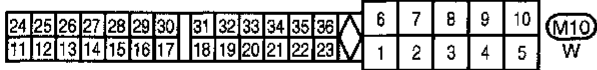
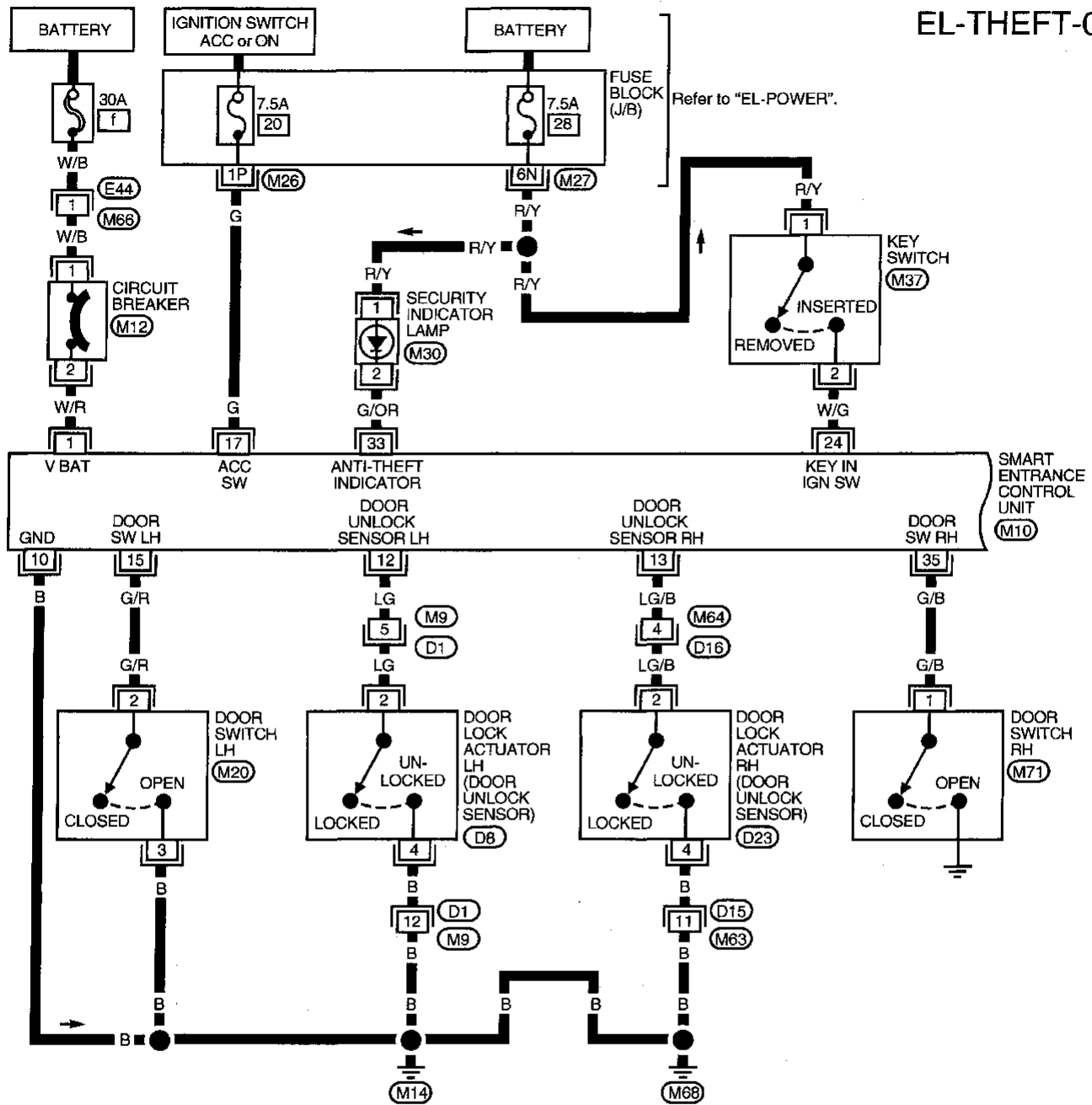

THEFT WARNING SYSTEM

Wiring Diagram — THEFT — (Cont'd)

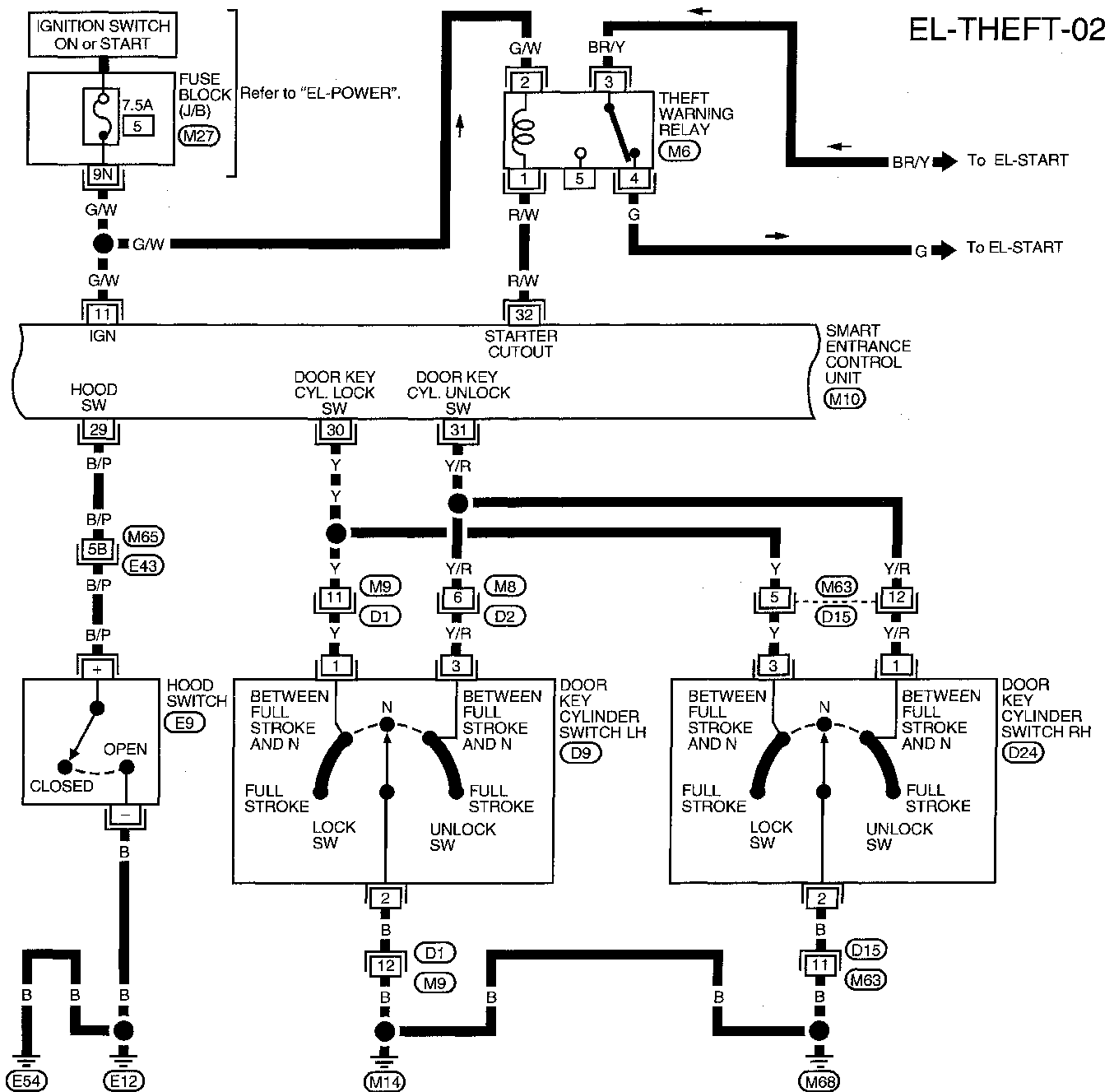

Refer to last page (Foldout page).

(M65) (E43)

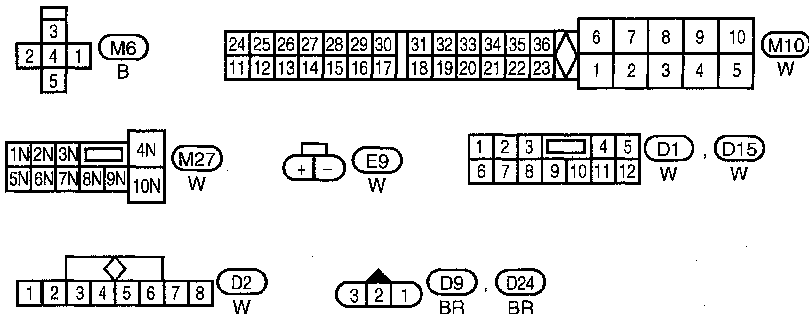

THEFT WARNING SYSTEM

Wiring Diagram — THEFT — (Cont'd)

GI
MA
EM
LC
EC
FE
CL
MT
AT
TF
PD
FA
RA
BR
ST
RS
BT
HA
EL
IDX

EL-THEFT-03

U : For USA
N : For Canada

Refer to "EL-POWER".

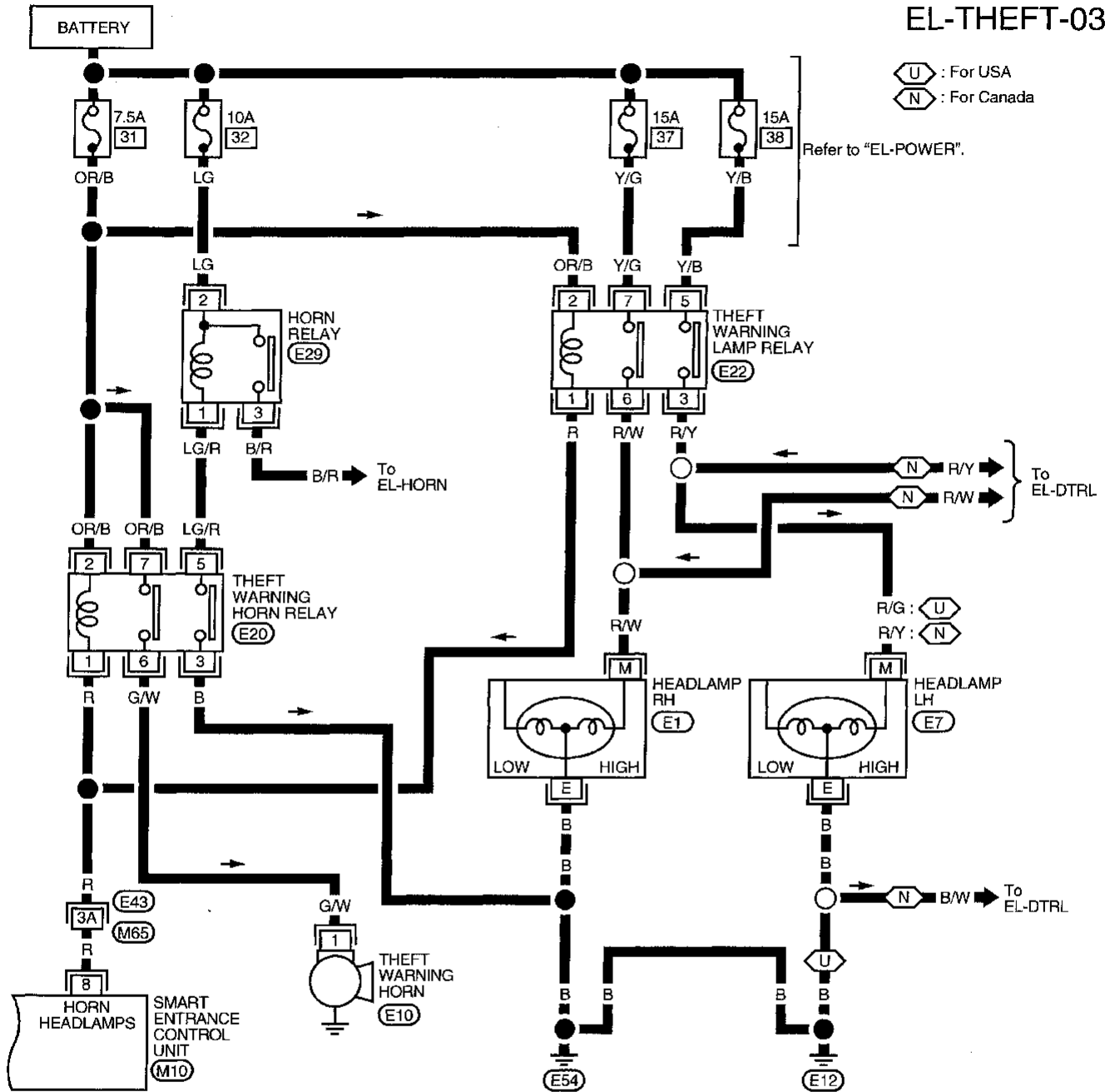

Refer to last page (Foldout page).

(M65), (E43)

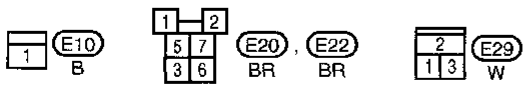
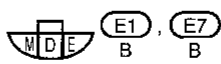
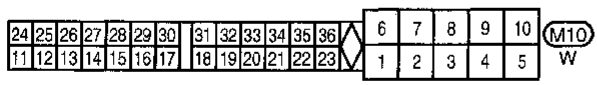

THEFT WARNING SYSTEM

Trouble Diagnoses

PRELIMINARY CHECK

The system operation is canceled by turning ignition switch to ACC at any step between START and ARMED in the following flow chart.

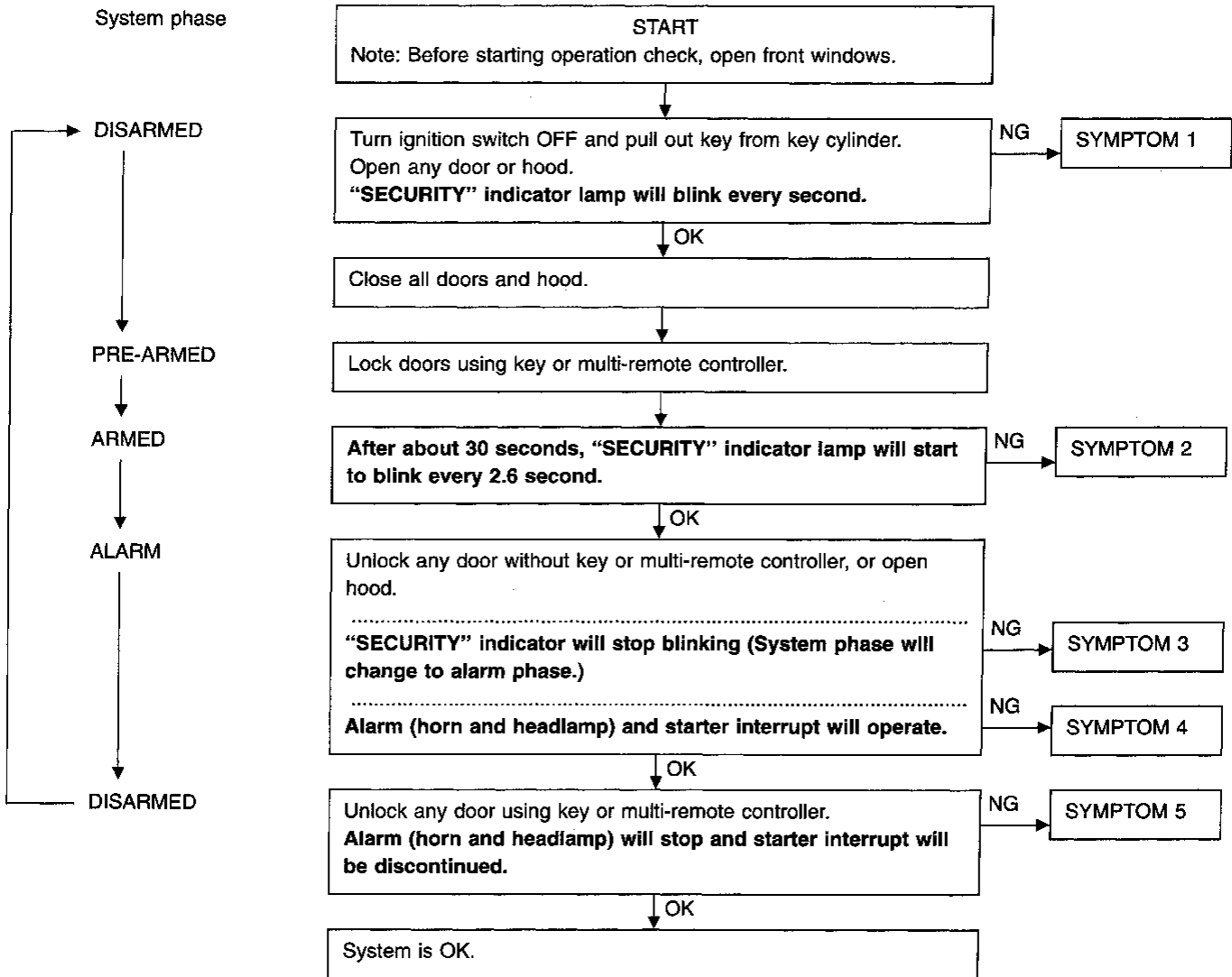

After performing preliminary check, go to symptom chart on next page.

THEFT WARNING SYSTEM

Trouble Diagnoses (Cont'd)

Before starting trouble diagnoses below, perform preliminary check, EL-196.

Symptom numbers in the symptom chart correspond with those of preliminary check.

SYMPTOM CHART

PROCEDURE		—	Power supply and ground circuit check		Diagnostic procedure							—	
			EL-196	EL-198	EL-198	EL-199	EL-201	EL-202	EL-203	EL-204	EL-205		EL-206
REFERENCE PAGE													
SYMPTOM													
1	Theft warning indicator does not turn "ON" or blinking.	X	X	X		X							
2	Theft warning system cannot be set by ...	All items	X	X	X	X		X					
		Door out side key	X	X	X				X				
		Multi-remote control	X	X	X								X
3	*1 Theft warning system does not alarm when ...	Any door is opened.	X	X	X	X							
		Any door is unlocked without using key or multi-remote controller	X	X	X			X					
4	Theft warning system does not activate.	All function	X	X	X	X		X					
		Horn alarm	X	X	X					X			
		Headlamp alarm	X	X	X						X		
		Starter interrupt	X	X	X							X	
5	Theft warning system cannot be canceled by ...	Door out side key	X	X	X				X				
		Multi-remote control	X	X	X								X

X : Applicable

*1: Make sure the system is in the armed phase.

GI

MA

EM

LC

EC

FE

GL

MT

AT

TF

PD

FA

RA

BR

ST

RS

BT

HA

EL

IDX

THEFT WARNING SYSTEM

Trouble Diagnoses (Cont'd)

POWER SUPPLY AND GROUND CIRCUIT CHECK

Power supply circuit check

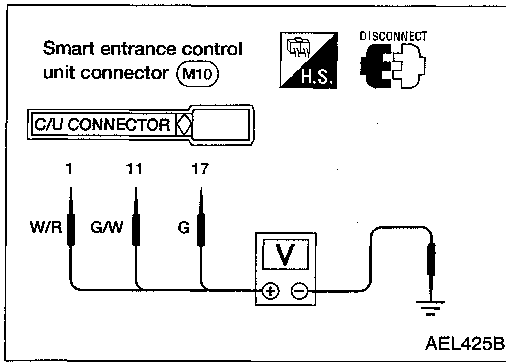

Terminals		Ignition switch position		
⊕	⊖	OFF	ACC	ON
①	Ground	Battery voltage	Battery voltage	Battery voltage
⑪	Ground	0V	0V	Battery voltage
⑰	Ground	0V	Battery voltage	Battery voltage

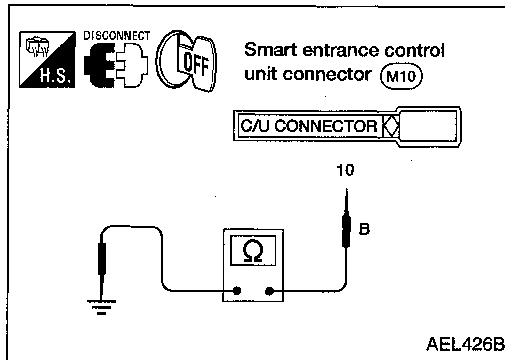

Ground circuit check

Terminal	Continuity
⑩ - Ground	Yes

THEFT WARNING SYSTEM

Trouble Diagnoses (Cont'd)

DIAGNOSTIC PROCEDURE 1-(1) (Door switch check)

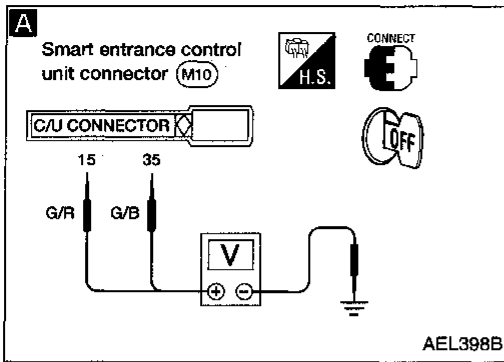

1. Turn ignition switch OFF and remove key from key cylinder.
2. Close all doors and hood.
"SECURITY" indicator lamp should turn off.
3. Open any door.
"SECURITY" indicator lamp should blink every second.

OK → Door switch is OK.

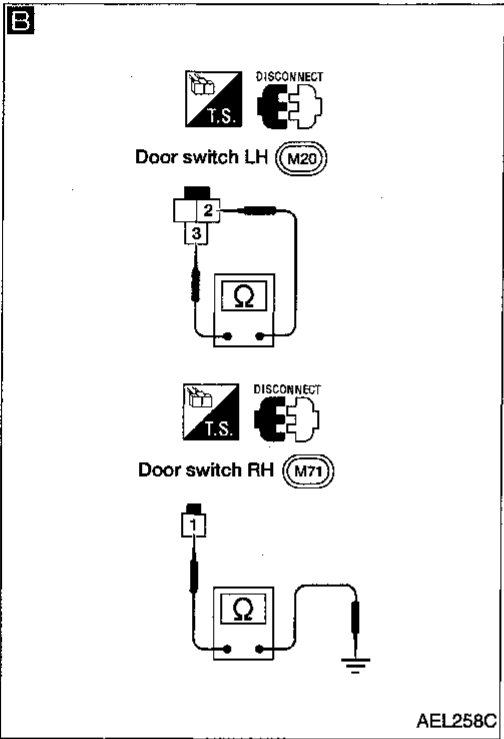

- A**
- CHECK DOOR SWITCH INPUT SIGNAL.**
Check voltage between control unit terminals (15) or (35) and ground.

	Terminals		Condi- tion	Voltage [V]
	⊕	⊖		
Door switch LH	(15)	Ground	Open	0
			Closed	Approx. 12
Door switch RH	(35)	Ground	Open	0
			Closed	Approx. 12

Refer to wiring diagram in EL-193.

OK → Door switch is OK.

- B**
- CHECK DOOR SWITCH.**
1. Disconnect door switch connector.
2. Check continuity between door switch terminals.

	Terminals	Condition	Continuity
Door switch LH	(2) - (3)	Closed	No
		Open	Yes
Door switch RH	(1) - Ground	Closed	No
		Open	Yes

NG → Replace door switch.

- OK
- Check the following.
- Door switch ground circuit (LH) or door switch ground condition
 - Harness for open or short between control unit and door switch

GI
MA
EM
LC
EC
FE
CL
MT
AT
TF
PD
FA
RA
BR
ST
RS
BT
HA
EL
IDX

THEFT WARNING SYSTEM

Trouble Diagnoses (Cont'd) DIAGNOSTIC PROCEDURE 1-(2) (Hood switch check)

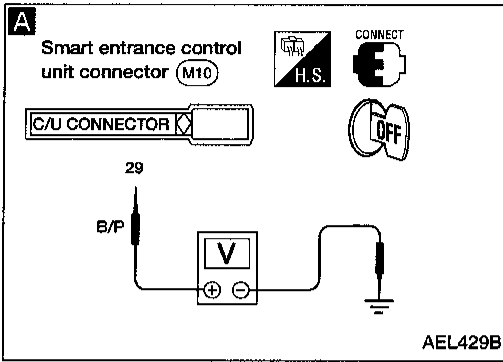

1. Turn ignition switch OFF and remove key from key cylinder.
2. Close all doors and hood.
"SECURITY" indicator lamp should turn off.
3. Open hood.
"SECURITY" indicator lamp should blink every second.

OK → Hood switch is OK.

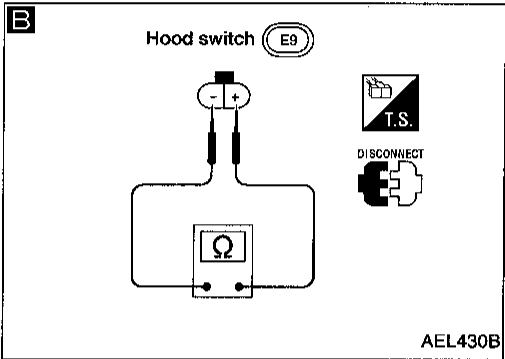

Check hood switch and hood fitting condition.

NG → Adjust installation of hood switch or hood.

A

CHECK HOOD SWITCH INPUT SIGNAL.
Check voltage between control unit terminal (29) and ground.

OK → Hood switch is OK.

Condition	Voltage [V]
Hood is open.	0
Hood is closed.	Approx. 12

Refer to wiring diagram in EL-194.

NG

B

CHECK HOOD SWITCH.
1. Disconnect hood switch connector.
2. Check continuity between hood switch terminals.

NG → Replace hood switch.

Terminals	Condition	Continuity
⊖ - ⊕	Pushed	No
	Released	Yes

OK

Check the following.

- Hood switch ground circuit
- Harness for open or short between control unit and hood switch

THEFT WARNING SYSTEM

Trouble Diagnoses (Cont'd)

DIAGNOSTIC PROCEDURE 2 (Security indicator lamp check)

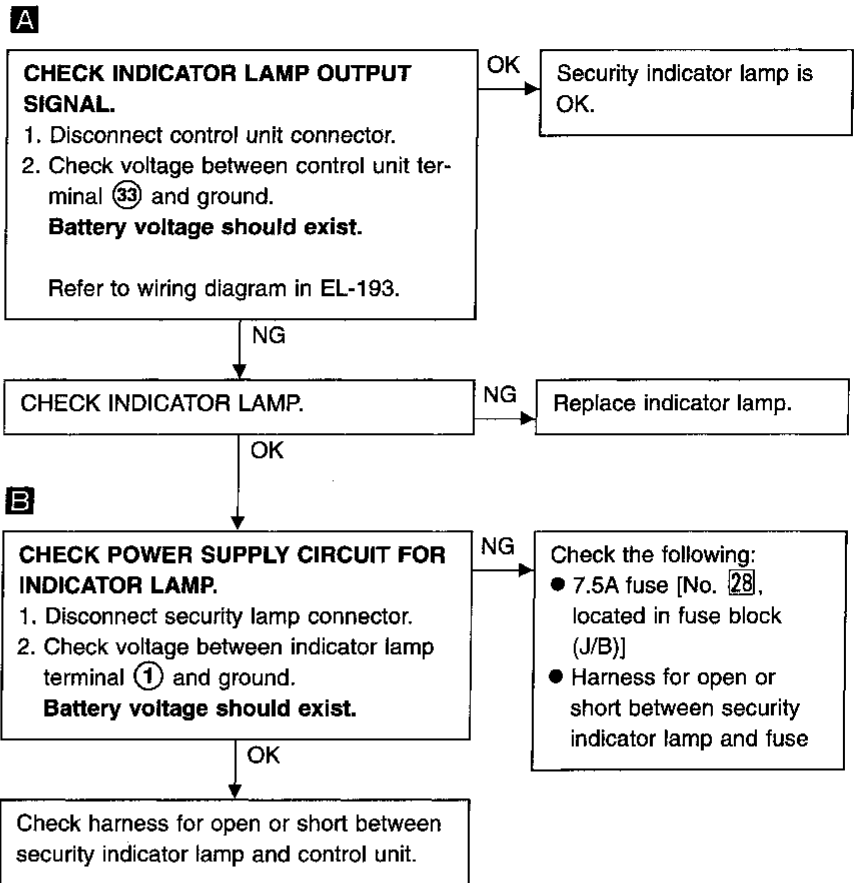
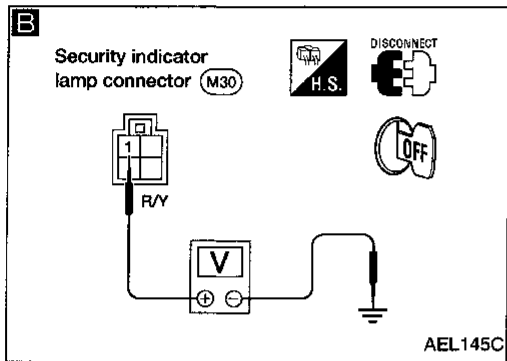
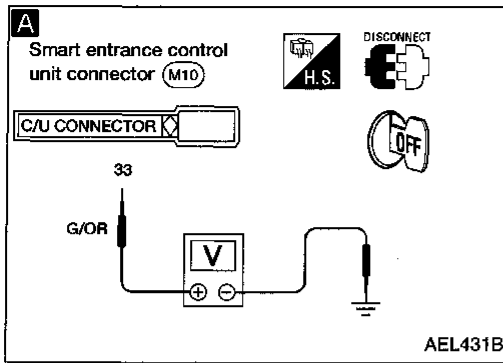

GI

MA

EM

LC

EC

FE

CL

MT

AT

TF

PD

FA

RA

BR

ST

RS

BT

HA

EL

IDX

THEFT WARNING SYSTEM

Trouble Diagnoses (Cont'd)

DIAGNOSTIC PROCEDURE 3 (Door unlock sensor check)

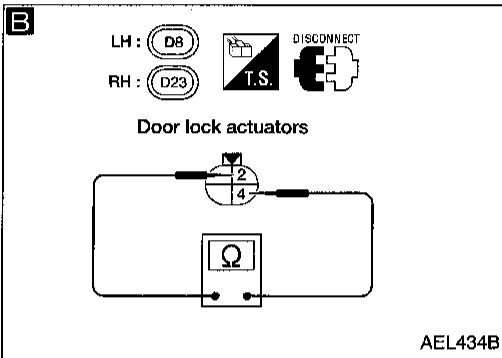
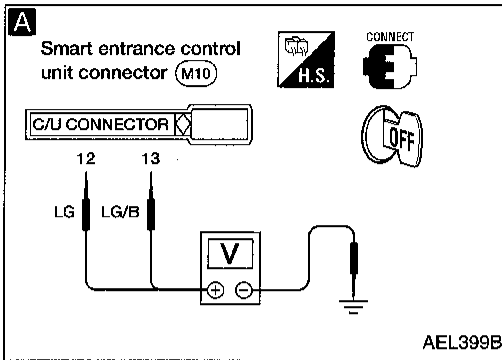

A

CHECK DOOR UNLOCK SENSOR INPUT SIGNAL.

Check voltage between control unit terminals (12) or (13) and ground.

	Terminals		Condition	Voltage [V]
	⊕	⊖		
Door LH	(12)	Ground	Locked	Approx. 12
			Unlocked	0
Door RH	(13)	Ground	Locked	Approx. 12
			Unlocked	0

Refer to wiring diagram in EL-193.

OK

Door unlock sensor is OK.

NG

B

CHECK DOOR UNLOCK SENSOR.

1. Disconnect door unlock sensor connector.
2. Check continuity between door unlock sensor terminals.

Terminals	Condition	Continuity
(4) - (2)	Locked	No
	Unlocked	Yes

NG

Replace door unlock sensor.

OK

Check the following.

- Door unlock sensor ground circuit
- Harness for open or short between control unit and door unlock sensor

THEFT WARNING SYSTEM

Trouble Diagnoses (Cont'd)

DIAGNOSTIC PROCEDURE 4

(Door key cylinder switch check)

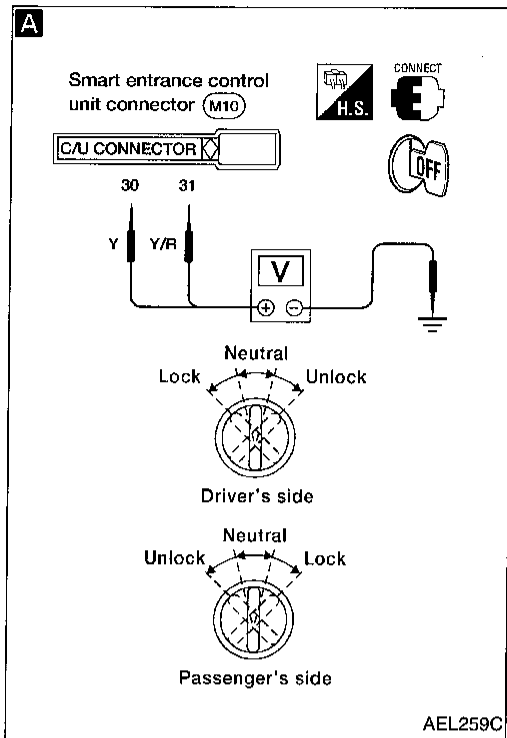

A

CHECK DOOR KEY CYLINDER SWITCH INPUT SIGNAL (LOCK/UNLOCK SIGNAL).

Check voltage between control unit terminals ③⑩ or ③⑪ and ground.

Terminals		Key position	Voltage [V]
⊕	⊖		
③⑩	Ground	Neutral	Approx. 12
		Lock	0
③⑪	Ground	Neutral	Approx. 12
		Unlock	0

Refer to wiring diagram in EL-194.

OK → Door key cylinder switch is OK.

B

CHECK DOOR KEY CYLINDER SWITCH.

1. Disconnect door key cylinder switch connector.
2. Check continuity between door key cylinder switch terminals.

Terminals	Key position	Continuity
LH: ① - ②	Neutral	No
RH: ③ - ②	Lock	Yes
LH: ③ - ②	Neutral	No
RH: ① - ②	Unlock	Yes

NG → Replace door key cylinder switch.

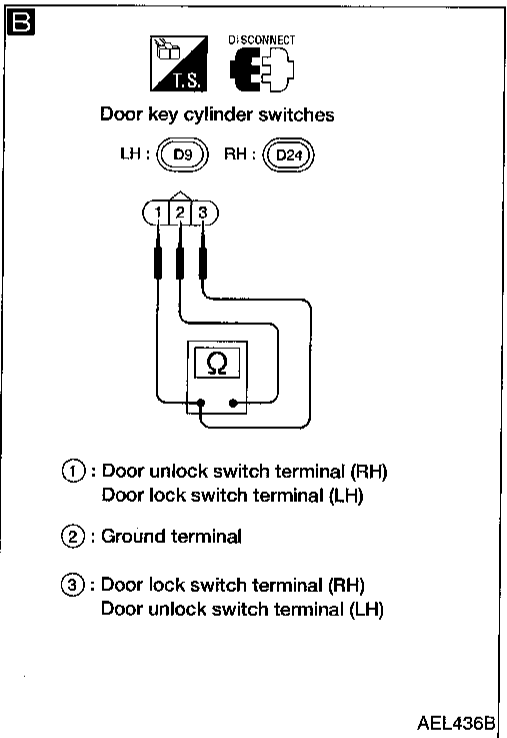

OK →

Check the following:

- Door key cylinder switch ground circuit
- Harness for open or short between control unit and door key cylinder switch

GI
MA
EM
LC
EC
FE
CL
MT
AT
TF
PD
FA
RA
BR
ST
RS
BT
HA
EL
IDX

THEFT WARNING SYSTEM

Trouble Diagnoses (Cont'd) DIAGNOSTIC PROCEDURE 5 (Theft warning horn alarm check)

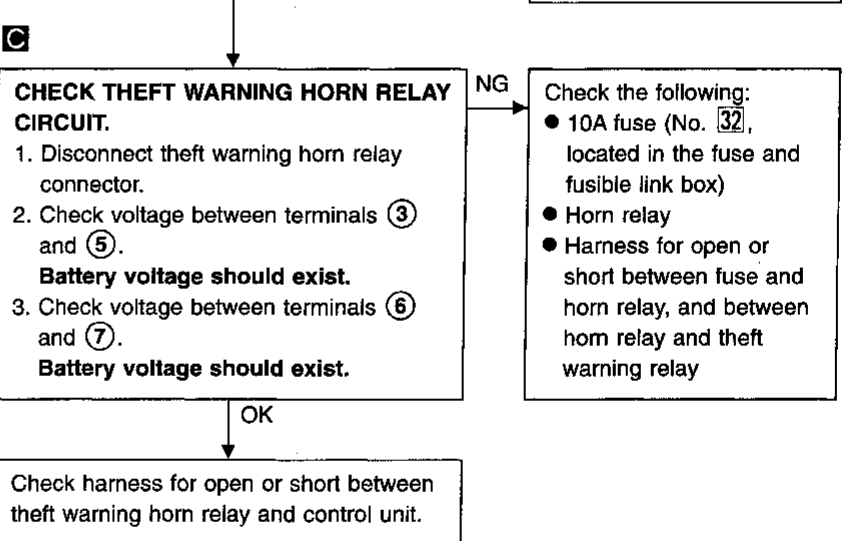
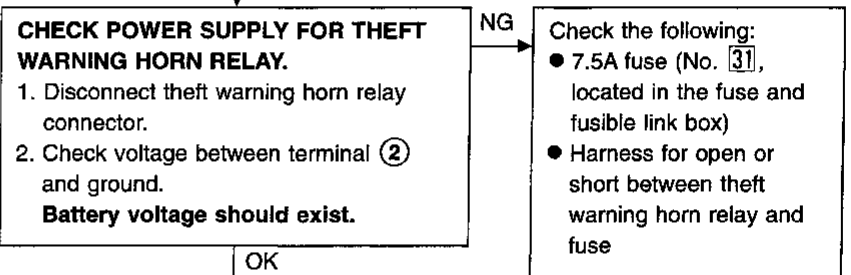
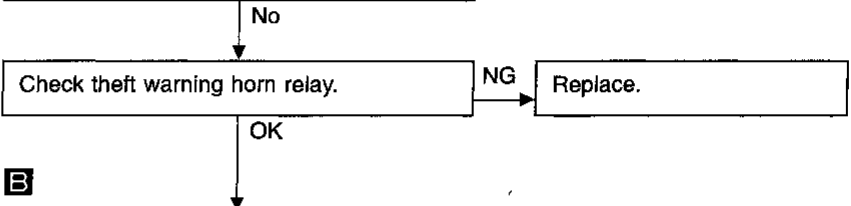
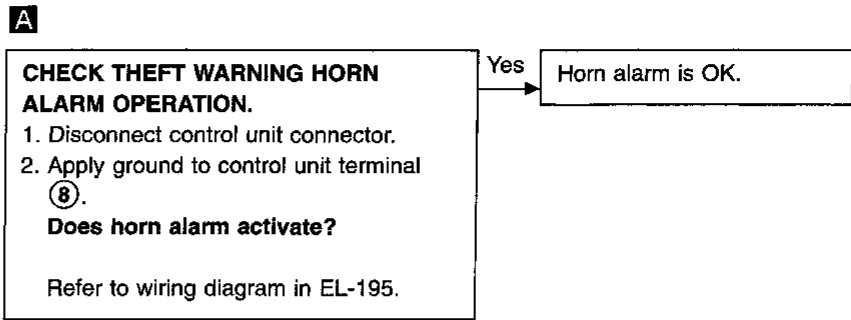
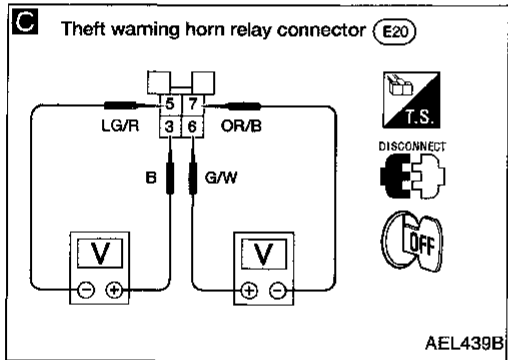
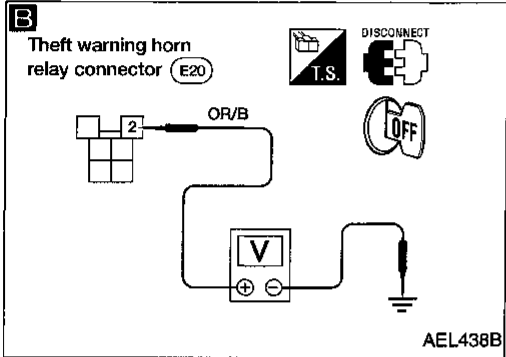
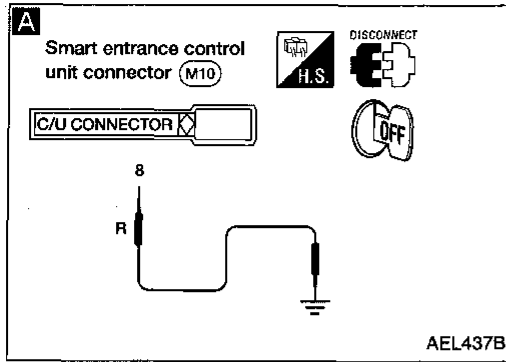

THEFT WARNING SYSTEM

Trouble Diagnoses (Cont'd)

DIAGNOSTIC PROCEDURE 6

(Theft warning headlamp alarm check)

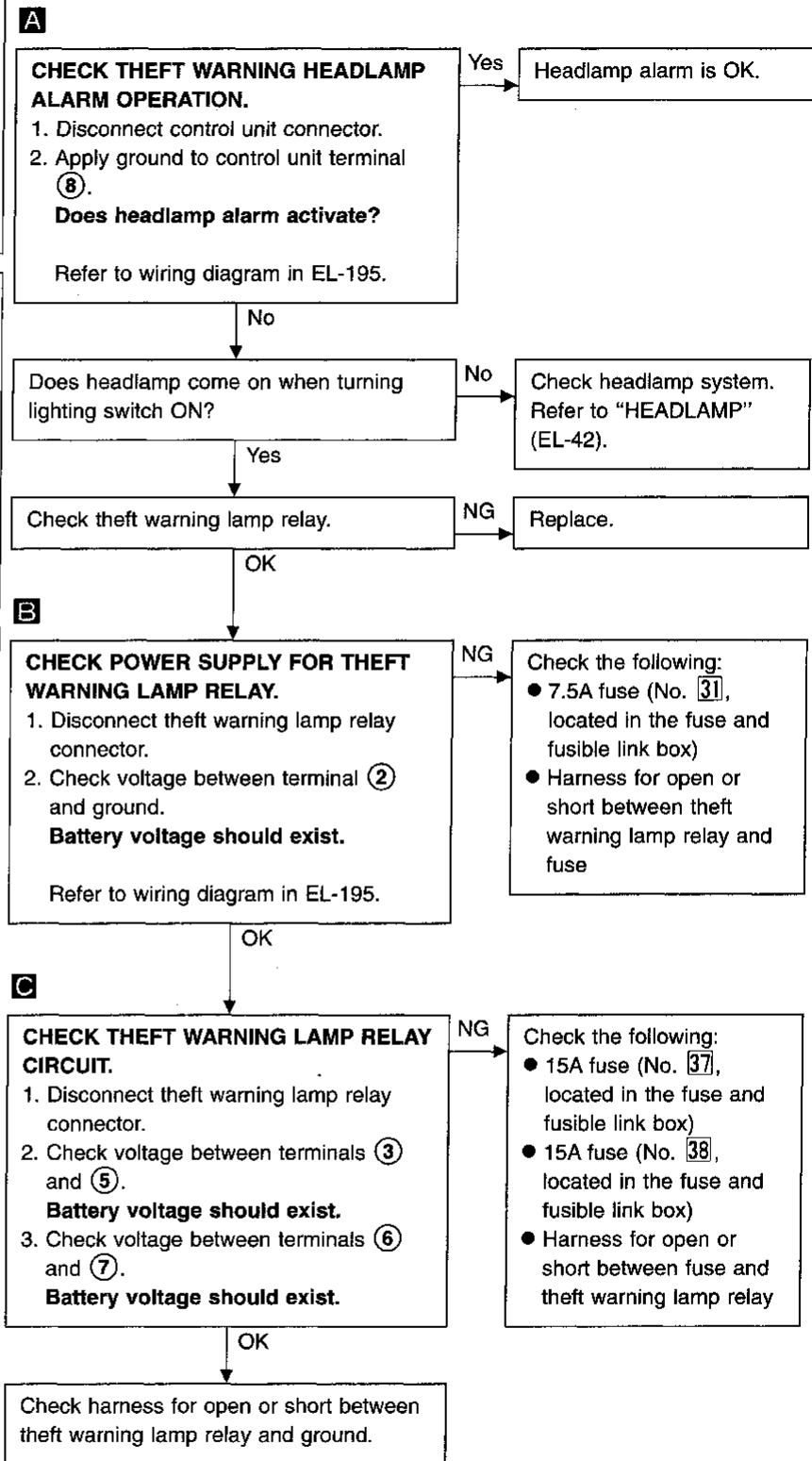
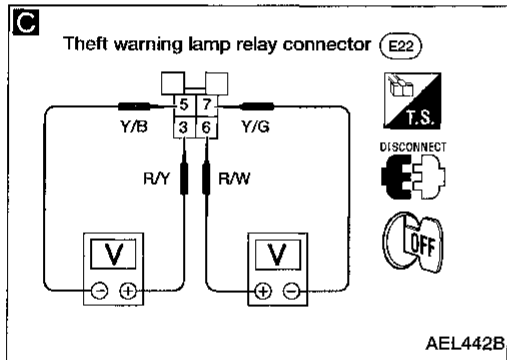
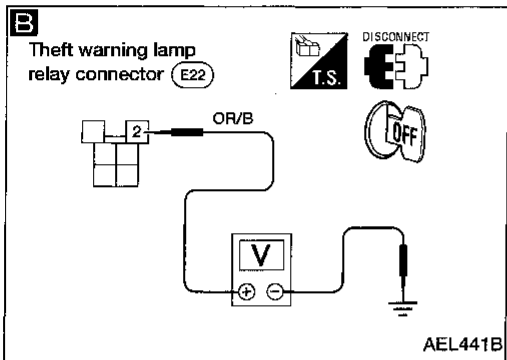
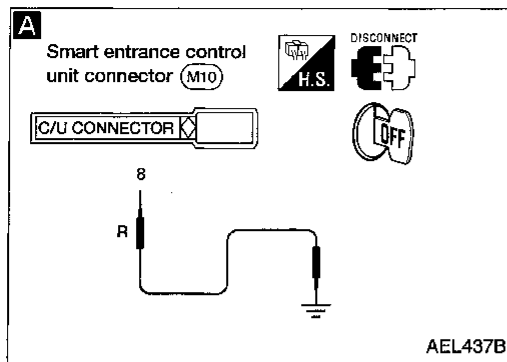

GI
MA
EM
LC
EC
FE
CL
MT
AT
TF
PD
FA
RA
BR
ST
RS
BT
HA
EL
IDX

THEFT WARNING SYSTEM

Trouble Diagnoses (Cont'd)

DIAGNOSTIC PROCEDURE 7

(Starter interrupt system check)

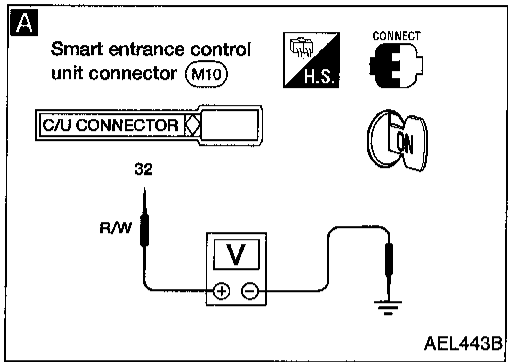

A

CHECK STARTER MOTOR INTERRUPT SIGNAL.

1. Turn ignition switch ON.
2. Check voltage between control unit terminal (32) and ground.

Condition	Voltage [V]
Except starter interrupted phase	Approx. 12
Starter interrupted phase	0

Refer to wiring diagram in EL-194.

NG

Check the following:

- 7.5A fuse [No. 5], located in fuse block (J/B)
- Harness for open or short between theft warning relay and fuse
- Harness for open or short between control unit and theft warning relay

OK

Check theft warning relay.

NG

Replace relay.

OK

Check starting system. Refer to "STARTING SYSTEM" (EL-27).

SMART ENTRANCE CONTROL UNIT

Description

The following systems are controlled by the smart entrance control unit.

- Warning chime
- Power door lock
- Multi-remote control system
- Theft warning system.

For detailed description and wiring diagrams, refer to the relevant pages for the each system.

The control unit receives data from the switches and sensors to control their corresponding system relays and actuators.

System	Input	Output
Warning chime	Key switch (Insert) Ignition switch (ON) Lighting switch (1st) Seat belt buckle switch Door switch LH	Warning chime
Power door lock	Door lock and unlock switches Key switch (Insert) Door switches Door unlock sensors Door key cylinder switches (lock/unlock)	Door lock actuators
Multi-remote control	Key switch (Insert) Ignition switch (ACC) Door switches Door unlock sensors Antenna (remote controller signal)	Theft warning horn relay Theft warning lamp relay Interior lamp Multi-remote control relay Door lock actuators
Theft warning	Ignition switch (ACC, ON) Door switches Hood switch Door key cylinder switches (lock/unlock) Door unlock sensors	Theft warning horn relay Theft warning lamp relay Theft warning relay (Starter interrupt) Security indicator

GI

MA

EM

LC

EC

FE

CL

MT

AT

TF

PD

FA

RA

BR

ST

RS

BT

HA

EL

IDX

SMART ENTRANCE CONTROL UNIT

Input/Output Operation Signal

Terminal No.	Wire color	Connections	Operated condition	Voltage (V) (Approximate values)	
1	W/R	Power source (C/B)	—	12V	
2	PU	Passenger door lock actuator	Door lock & unlock switch	Unlocked	12V
3	G/W	Driver door lock actuator		Free	0V
4	L	Driver and passenger door lock actuators	Door lock & unlock switch	Locked	12V
				Free	0V
7	P/B	Multi-remote control relay	When doors are locked using remote controller	12V → 0V	
8	R	Theft warning horn relay Theft warning lamp relay	When panic alarm is operated using remote controller	12V → 0V	
9	R/B	Room lamp	When interior lamp is operated using remote controller. (Lamp switch in DOOR position)	12V → 0V	
10	B	Ground	—	—	
11	G/W	Ignition switch (ON)	Ignition key is in ON position	12V	
12	LG	Driver door unlock sensor	Driver door: Locked → Unlocked	12V → 0V	
13	LG/B	Passenger door unlock sensor	Passenger door: Locked → Unlocked	12V → 0V	
15	G/R	Driver door switch	OFF (Closed) → ON (Open)	12V → 0V	
17	G	Ignition switch (ACC)	ACC position	12V	
18	LG/R	Door lock/unlock switches (lock)	Neutral → Locks	12V → 0V	
19	BR	Door lock/unlock switches (unlock)	Neutral → Unlocks	12V → 0V	
21	B/P	Seat belt buckle switch	Unfasten → Fasten (Ignition key is in ON position)	0V → 12V	
24	W/G	Ignition key switch (Insert)	IGN key inserted → IGN key removed from IGN key cylinder	12V → 0V	
25	L/R	Lighting switch (1ST)	1ST, 2ND positions: ON → OFF	12V → 0V	
29	B/P	Hood switch	ON (Open) → OFF (Closed)	0V → 12V	
30	Y	Door key cylinder lock switch	OFF (Neutral) → ON (Locked)	12V → 0V	
31	Y/R	Door key cylinder unlock switch	OFF (Neutral) → ON (Unlocked)	12V → 0V	
32	R/W	Theft warning relay (Starter cut)	OFF → ON (Ignition key is in ON position)	12V → 0V	
33	G/OR	Theft warning indicator	Goes off → Illuminates	12V → 0V	
35	G/B	Passenger door switch	OFF (Closed) → ON (Open)	12V → 0V	

SMART ENTRANCE CONTROL UNIT

NOTES

GI

MA

EM

LC

EC

FE

CL

MT

AT

TF

PD

FA

RA

BR

ST

RS

BT

HA

EL

IDX

SMART ENTRANCE CONTROL UNIT

Schematic

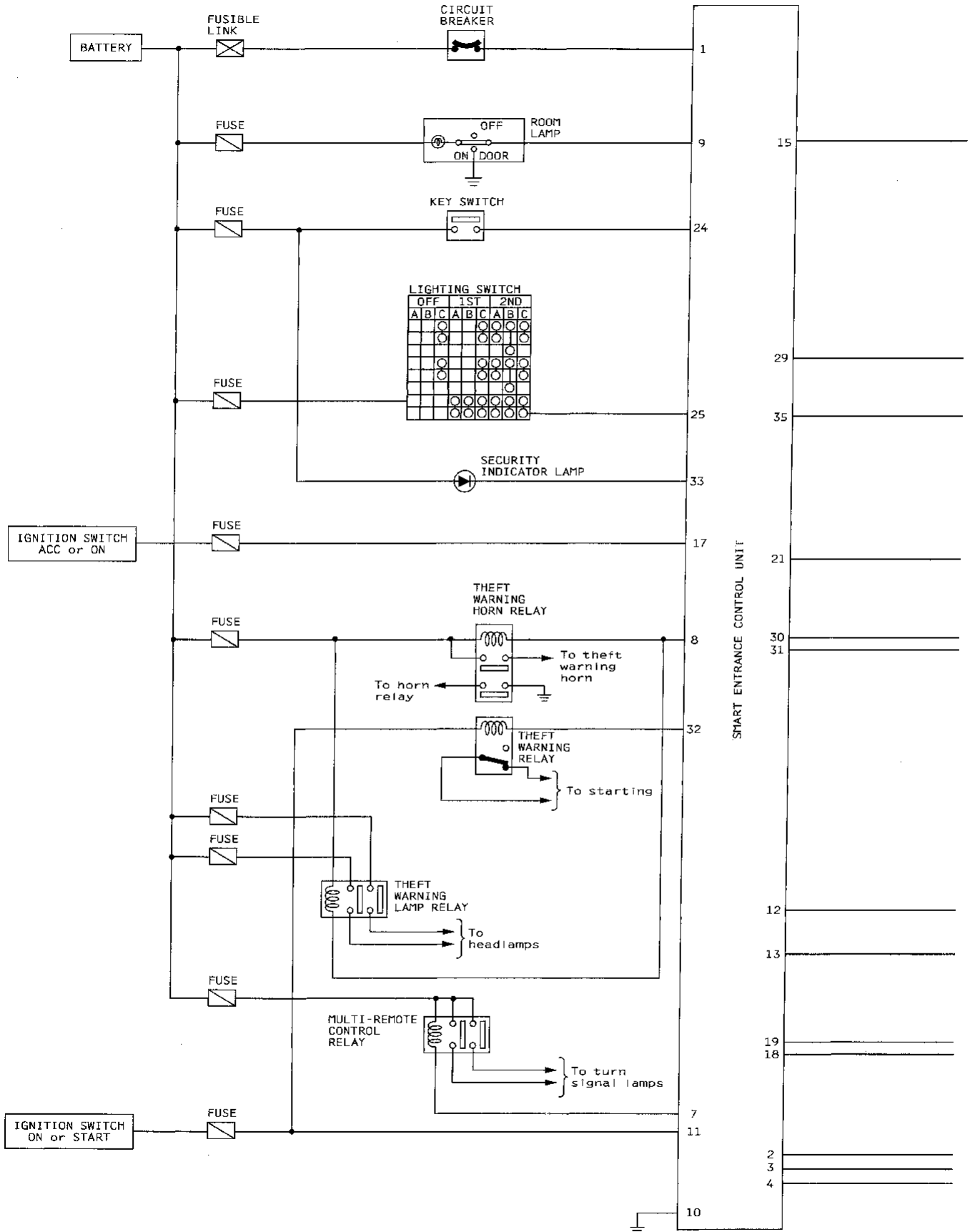

SMART ENTRANCE CONTROL UNIT

Schematic (Cont'd)

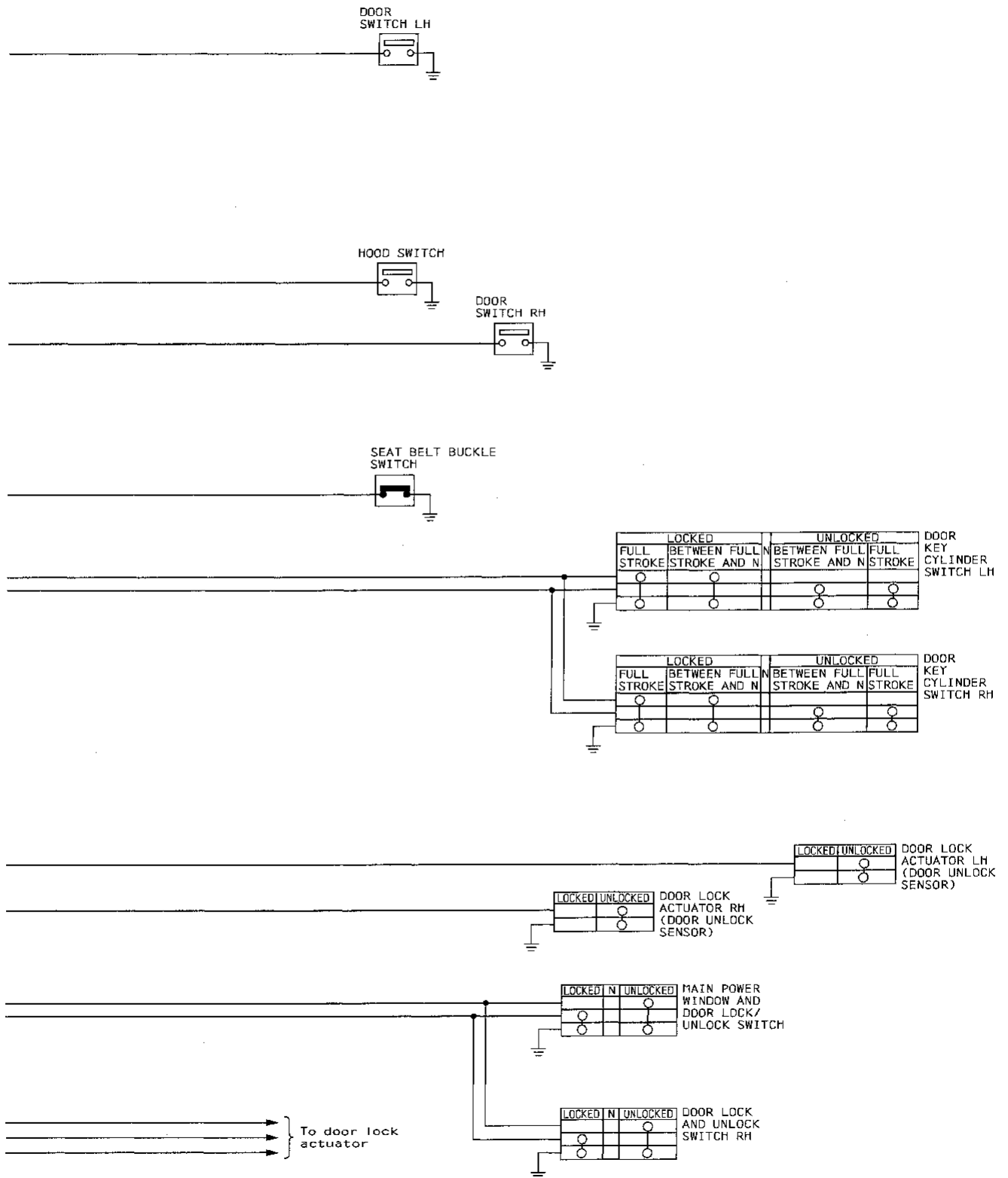

GI
MA
EM
LC
EC
FE
CL
MT
AT
TF
PD
FA
RA
BR
ST
RS
BT
HA
EL
IDX

LOCATION OF ELECTRICAL UNITS

Engine Compartment

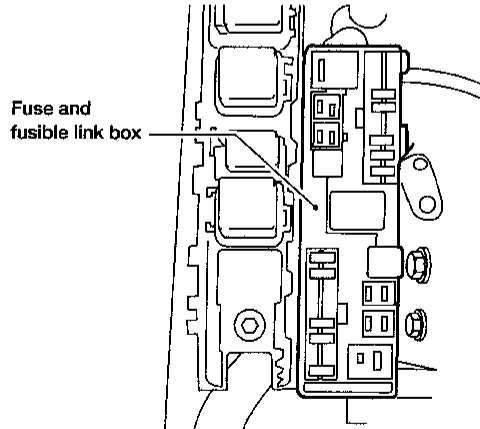
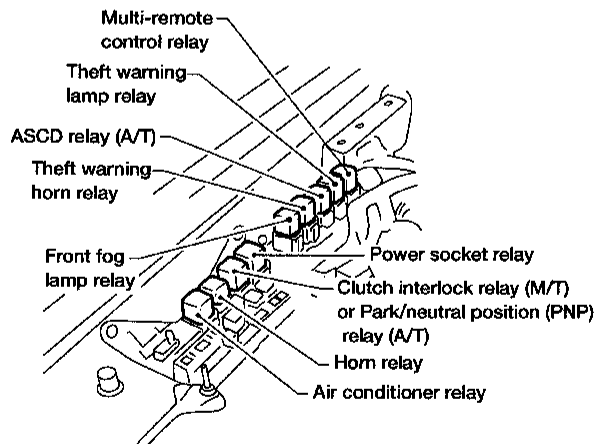
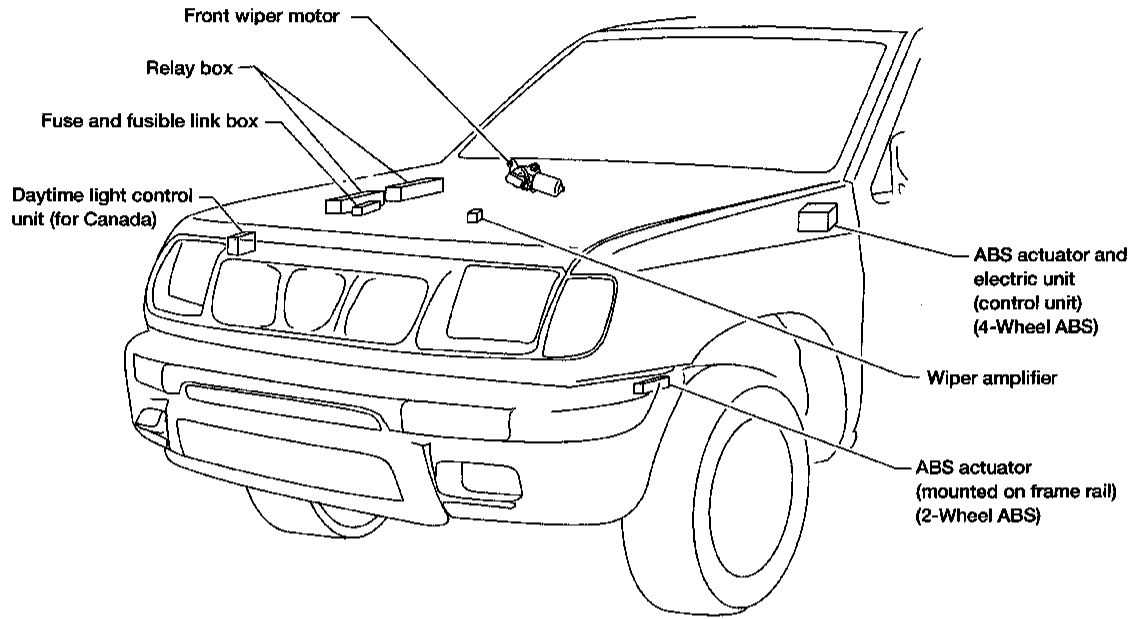

LOCATION OF ELECTRICAL UNITS

Passenger Compartment

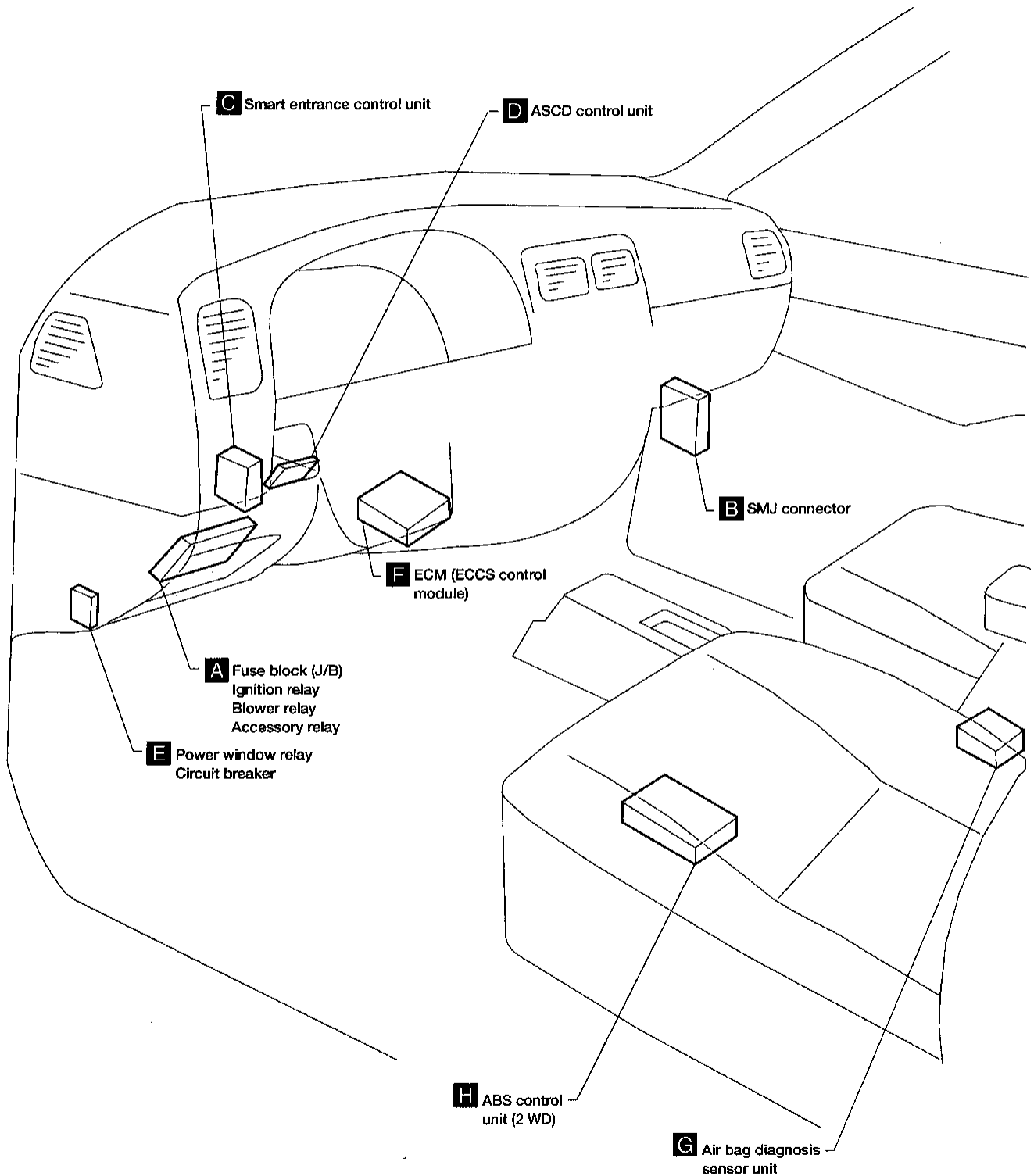

GI
MA
EM
LC
EC
FE
CL
MT
AT
TF
PD
FA
RA
BR
ST
RS
BT
HA
EL
IDX

LOCATION OF ELECTRICAL UNITS

Passenger Compartment (Cont'd)

A

View of rear of fuse block (J/B)

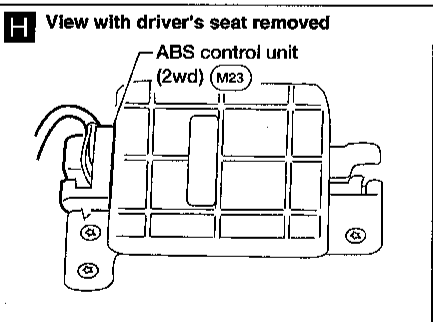
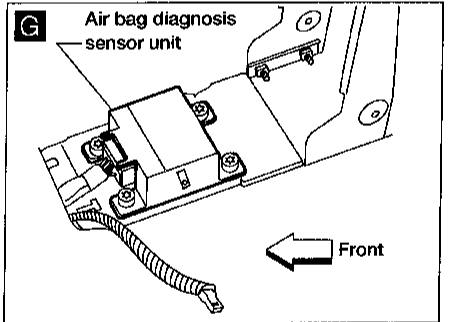
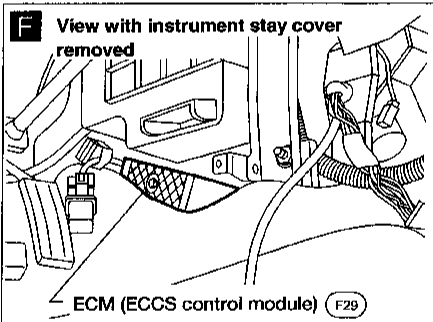
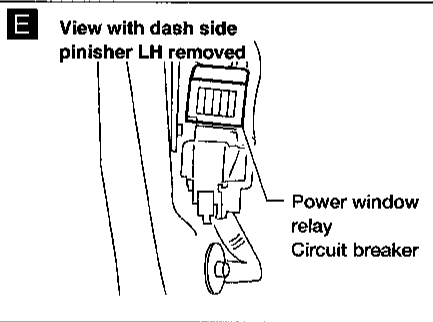
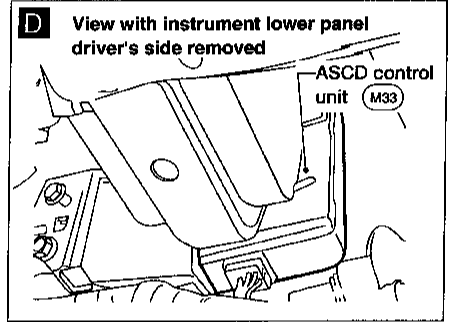
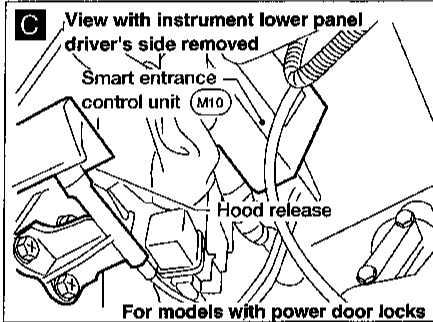
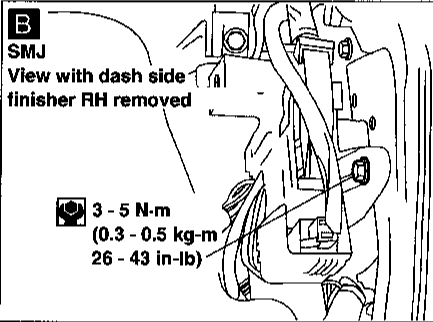
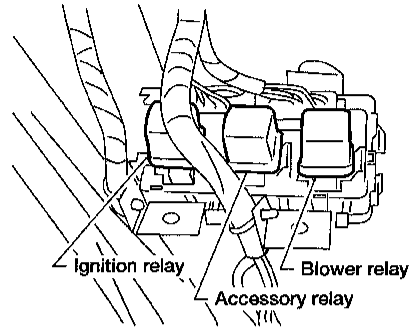
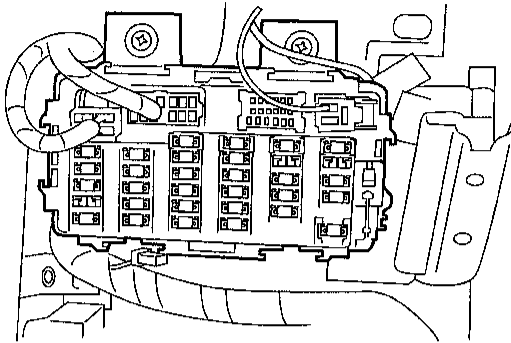

HARNES LAYOUT

Outline

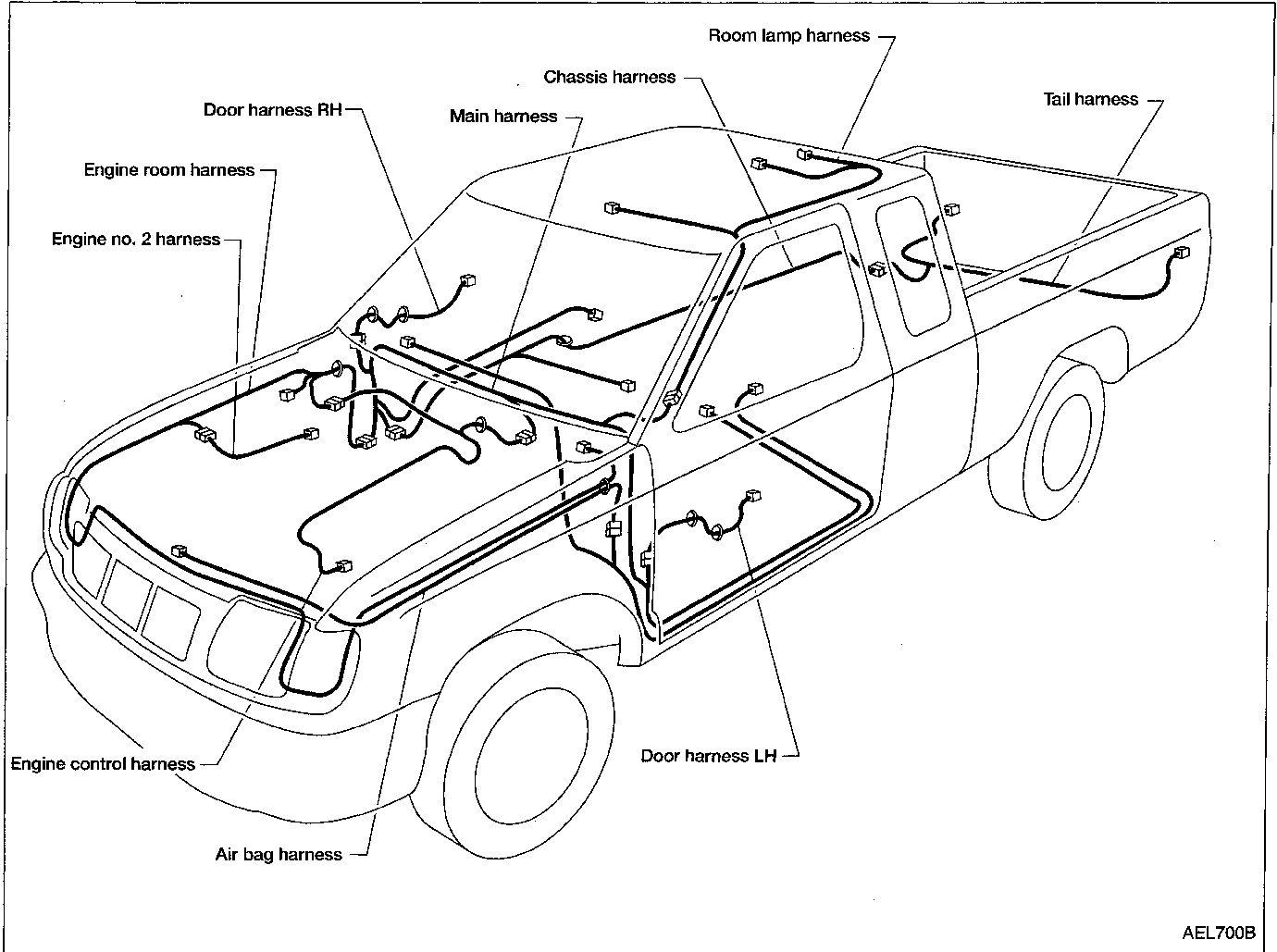

NOTE: For detailed ground distribution information, refer to "GROUND DISTRIBUTION", EL-16.

CI
MA
EM
LC
EC
FE
CL
MT
AT
TF
PD
FA
RA
BR
ST
RS
BT
HA
EL
IDX

HARNESS LAYOUT

How to Read Harness Layout

Example:

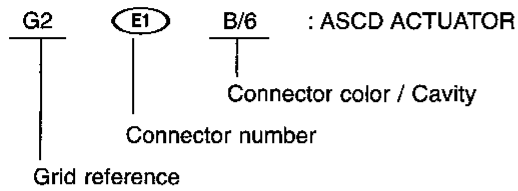

The following Harness Layouts use a map style grid to help locate connectors on the drawings:

- Main Harness
- Engine Room Harness (Engine Compartment)
- Engine Control Harness

To use the grid reference

- 1) Find the desired connector number on the connector list.
- 2) Find the grid reference.
- 3) On the drawing, find the crossing of the grid reference letter column and number row.
- 4) Find the connector number in the crossing zone.
- 5) Follow the line (if used) to the connector.

CONNECTOR SYMBOL

Main symbols of connector (in Harness Layout) are indicated in the below.

Connector type	Water proof type		Standard type	
	Male	Female	Male	Female
<ul style="list-style-type: none"> ● Cavity: Less than 4 ● Relay connector 				
<ul style="list-style-type: none"> ● Cavity: From 5 to 8 				
<ul style="list-style-type: none"> ● Cavity: More than 9 				
<ul style="list-style-type: none"> ● Ground terminal etc. 	—			

HARNES LAYOUT

NOTES

GI

MA

EM

LC

EC

FE

CL

MT

AT

TF

PD

FA

RA

BR

ST

RS

BT

HA

EL

IDX

HARNESS LAYOUT

Main Harness

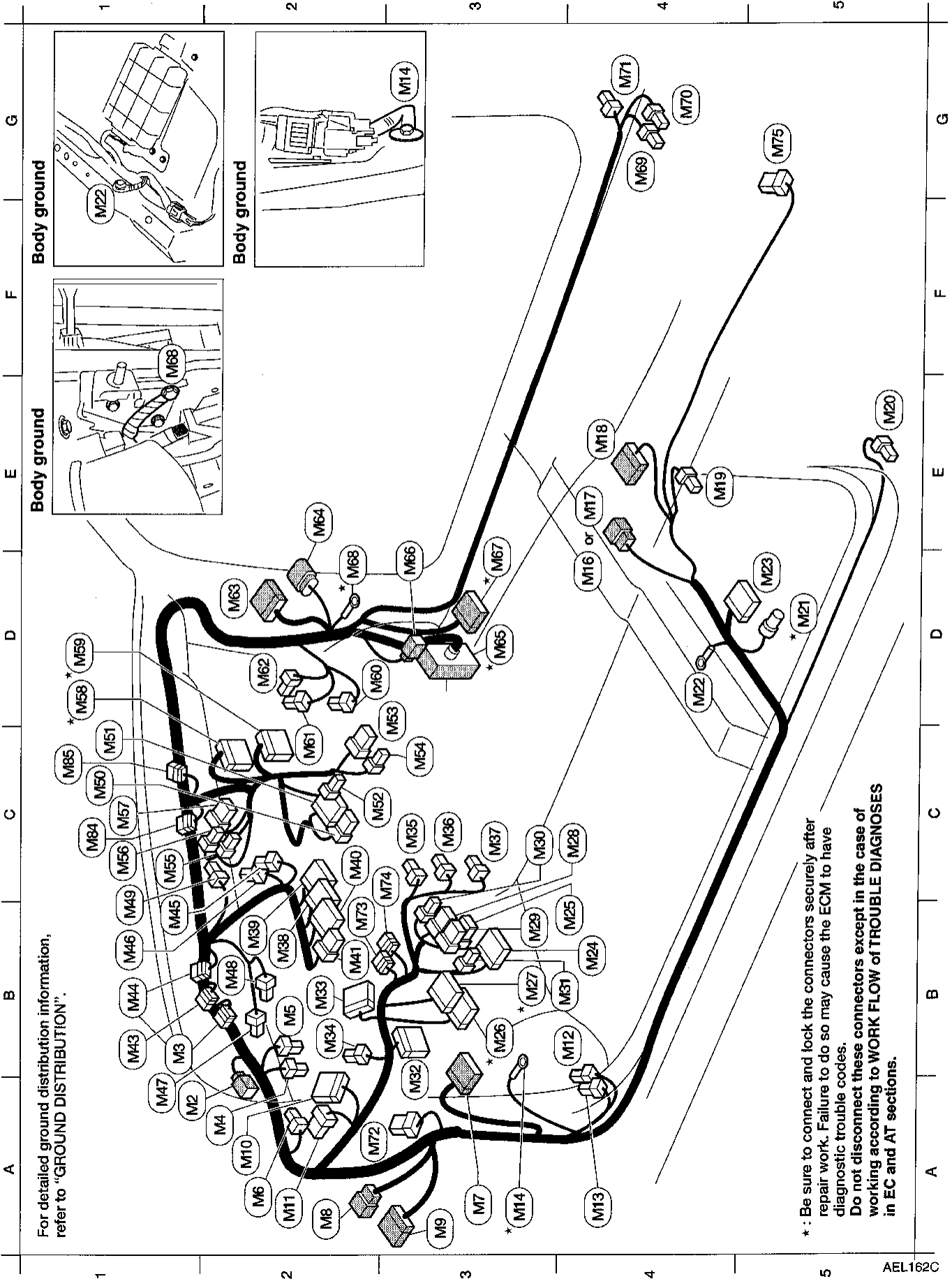

AEL162C

HARNES LAYOUT

Main Harness (Cont'd)

A1	(M2) W/4 : To (R1)	(M60) W/6 : Audio unit	
B1	(M3) GY/4 : Diode	(M51) W/10 : Audio unit	
A2	(M4) L/2 : ASCD clutch switch (with M/T)	(M52) B/2 : Cigarette lighter socket	
B2	(M5) L/2 : Clutch interlock switch (with M/T)	(M63) W/8 : Hazard switch	
A2	(M6) B/5 : Theft warning relay	(M54) B/2 : Power socket	
A3	(M7) W/18 : To (E3) (with 4-wheel ABS)	(M55) W/3 : Air conditioner switch	
A2	(M8) W/8 : To (D2)	(M56) W/3 : Fan switch illumination	
A3	(M9) W/12 : To (D1)	(M57) W/6 : Fan switch	
A3	(M10) W/36 : Smart entrance control unit (with power door locks)	D1 * (M58) W/16 : To (F28)	
A2	(M11) W/8 : Warning chime unit (without power door locks)	D1 * (M59) W/18 : To (F27)	
B4	(M12) W/2 : Circuit breaker	D2 (M60) W/3 : Thermo control amplifier	
A4	(M13) L/4 : Power window relay	C2 (M61) BR/4 : Fan resistor	
A3 *	(M14) — : Body ground	D2 (M62) W/2 : Blower motor	
D4	(M16) W/6 : To (C1) (with 4-wheel ABS)	D2 (M63) W/12 : To (D15)	
E4	(M17) W/8 : To (C2) (with 2-wheel ABS)	E2 (M64) W/6 : To (D16)	
E4	(M18) W/16 : To (Zr)	D3 * (M65) SMJ : To (E43)	
E4	(M19) W/3 : Seat belt buckle switch	D3 (M66) B/2 : To (E44)	
E5	(M20) B/3 : Door switch LH	D3 * (M67) W/18 : To (C1)	
D5 *	(M21) GY/4 : Rear heated oxygen sensor	D2 * (M68) — : Body ground	
D4	(M22) — : Body ground (with 2-wheel ABS)	G4 (M69) GY/2 : G-sensor (with 4-wheel ABS)	
D5	(M23) GY/17 : ABS control unit (with 2-wheel ABS)	G4 (M70) GY/2 : G-sensor (with 4-wheel ABS)	
B4	(M24) GY/14 : Data link connector for CONSULT	G4 (M71) BR/1 : Door switch RH	
		A3 (M72) GY/12 : Door mirror remote control switch	
		B2 (M73) W/6 : Joint connector-8	
		C3 (M74) W/6 : Joint connector-7	
		G5 (M75) W/8 : Subwoofer amplifier	
		C1 (M84) W/6 : Joint connector-5	
		C1 (M86) W/6 : Joint connector-6	

* : Be sure to connect and lock the connectors securely after repair work. Failure to do so may cause the ECM to have diagnostic trouble codes. Do not disconnect these connectors except in the case of working according to WORK FLOW of TROUBLE DIAGNOSES in EC and AT sections.

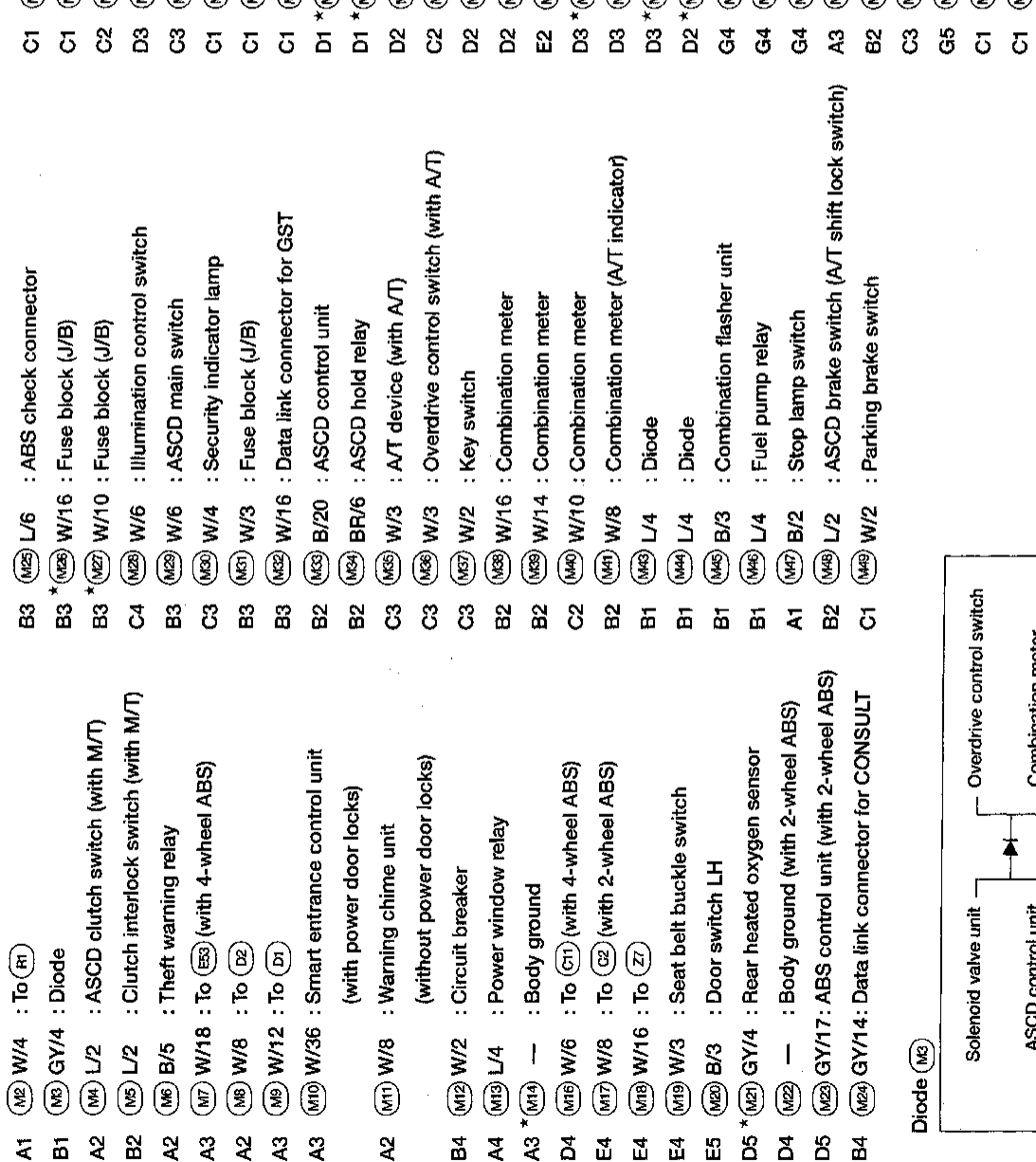

GI
 MA
 EM
 LG
 EC
 FE
 CL
 MT
 AT
 TF
 PD
 FA
 RA
 BR
 ST
 PS
 BT
 HA
 EL
 IDX

HARNESS LAYOUT

Engine Room Harness

ENGINE COMPARTMENT

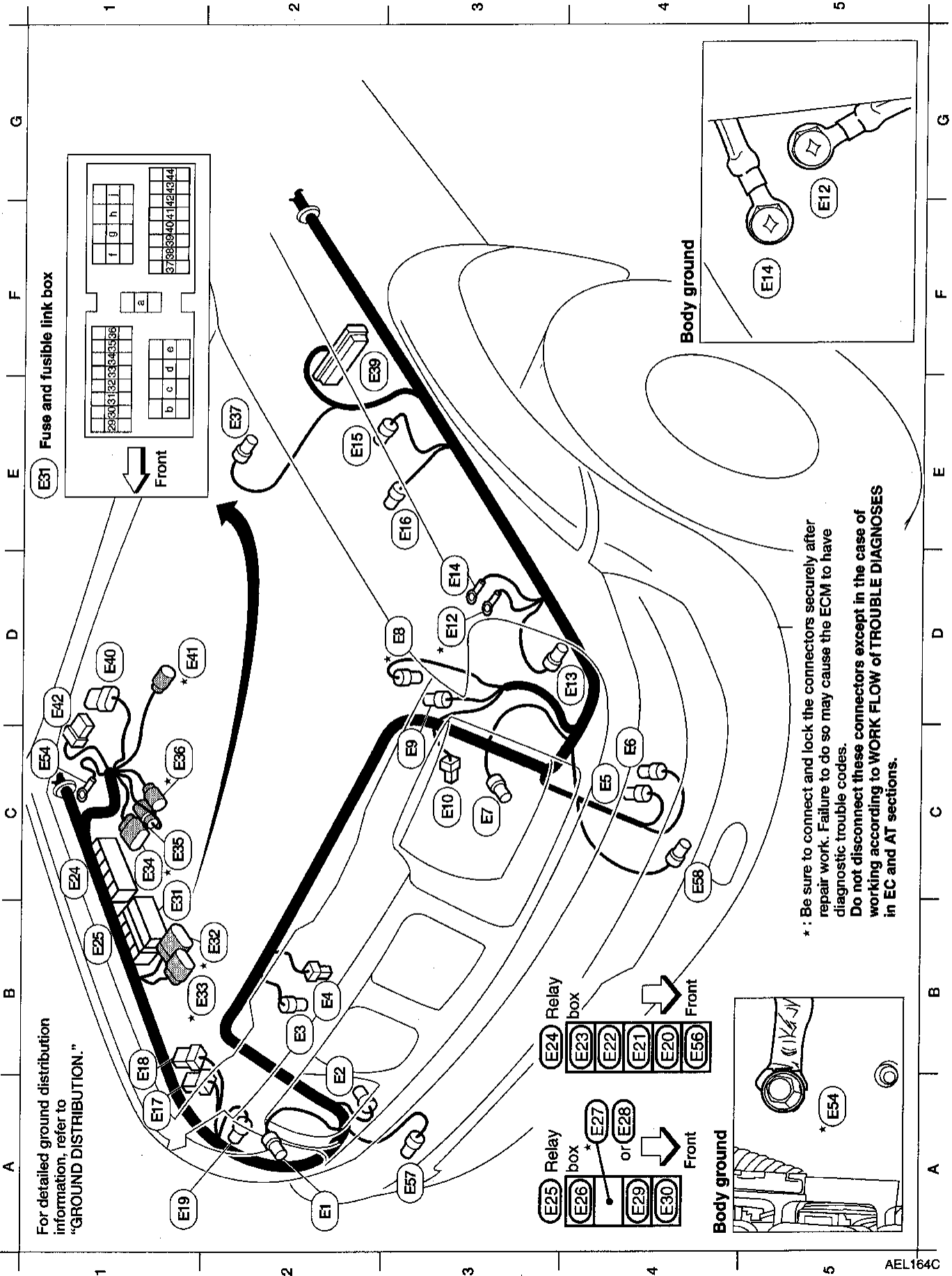

AEL164C

HARNESS LAYOUT

Engine Room Harness (Cont'd)

A2	(E1) B/3 : Head lamp RH	E3	(E15) GY/4 : ASCD pump (with ASCD)	A4	(E30) L/4 : Air conditioner relay
B3	(E2) GY/2 : Front wheel sensor RH (with 4-wheel ABS)	E3	(E16) BR/2 : Front wheel sensor LH (with 4-wheel ABS)	B1	(E26) — : Fuse and fusible link box
B2	(E3) B/2 : Dual pressure sensor	A1	(E17) GY/8 : Daytime light control unit (with DTRL)	B2	* (E32) GY/9 : To (E202)
B2	(E4) B/1 : Horn	B1	(E18) GY/6 : Daytime light control unit (with DTRL)	B1	* (E33) GY/6 : To (E20) (with M/T)
C4	(E5) BR/2 : Washer fluid level switch (for Canada)	A1	(E19) GY/3 : Front combination lamp RH	C1	(E34) GY/8 : Park/neutral position (PNP) switch (with A/T)
C4	(E6) GY/2 : Washer motor	B4	(E20) BR/6 : Theft warning horn relay	C1	* (E36) W/2 : Park/neutral position (PNP) switch (with A/T)
C3	(E7) B/3 : Headlamp LH	B4	(E21) B/5 : ASCD relay	C1	* (E36) GY/3 : Solenoid valve unit
D3	* (E8) W/2 : Intake air temperature sensor	B4	(E22) BR/6 : Theft warning lamp relay	E2	(E37) GY/2 : Brake fluid level switch
C3	(E9) GY/2 : Hood switch	B4	(E23) BR/6 : Multi-remote control relay	F2	(E38) B/27 : ABS actuator and electric unit (control unit) (with 4-wheel ABS)
C3	(E10) B/1 : Theft warning horn	B1	(E24) — : Relay box	D1	(E40) B/8 : Wiper amplifier
D3	* (E12) — : Body ground	C1	(E25) — : Relay box	D1	* (E41) GY/3 : To (E25)
D4	(E13) GY/3 : Front combination lamp LH	A4	(E26) L/4 : Power socket relay	D1	(E42) W/6 : Wiper motor
E3	(E14) — : Body ground	A4	* (E27) BR/6 : Park/neutral position (PNP) relay (with A/T)	C1	* (E44) — : Body ground
		A4	(E28) L/4 : Clutch interlock relay (with M/T)	B4	(E46) L/5 : Front fog lamp relay (Relay box)
		A4	(E28) W/3 : Horn relay	A3	(E47) B/2 : Front fog lamp RH
				C4	(E48) B/2 : Front fog lamp LH

* : Be sure to connect and lock the connectors securely after repair work. Failure to do so may cause the ECM to have diagnostic trouble codes.
 Do not disconnect these connectors except in the case of working according to WORK FLOW of TROUBLE DIAGNOSES in EC and AT sections.

GI
 MA
 EM
 LC
 EC
 FE
 CL
 MT
 AT
 TF
 PD
 FA
 RA
 BR
 ST
 RS
 BT
 HA
 EL
 IDX

HARNESS LAYOUT

Engine Room Harness (Cont'd)

PASSENGER COMPARTMENT

- * E43 W/48 : To (M65)
- E44 B/2 : To (M66)
- E45 W/8 : Combination switch (Lighting switch)
- E46 L/8 : Wiper switch
- E47 W/6 : Combination switch (Turn signal switch)
- * E48 W/6 : Ignition switch
- * E49 W/12 : Fuse block (J/B)
- E50 W/4 : Fuse block (J/B)
- E51 W/2 : Front fog lamp sub-harness (without fog lamps)
- E52 B/2 : Fuse block (J/B)
- E53 W/18 : To (M7) (with 4-wheel ABS)
- E59 B/2 : Combination switch (Front fog lamp switch)

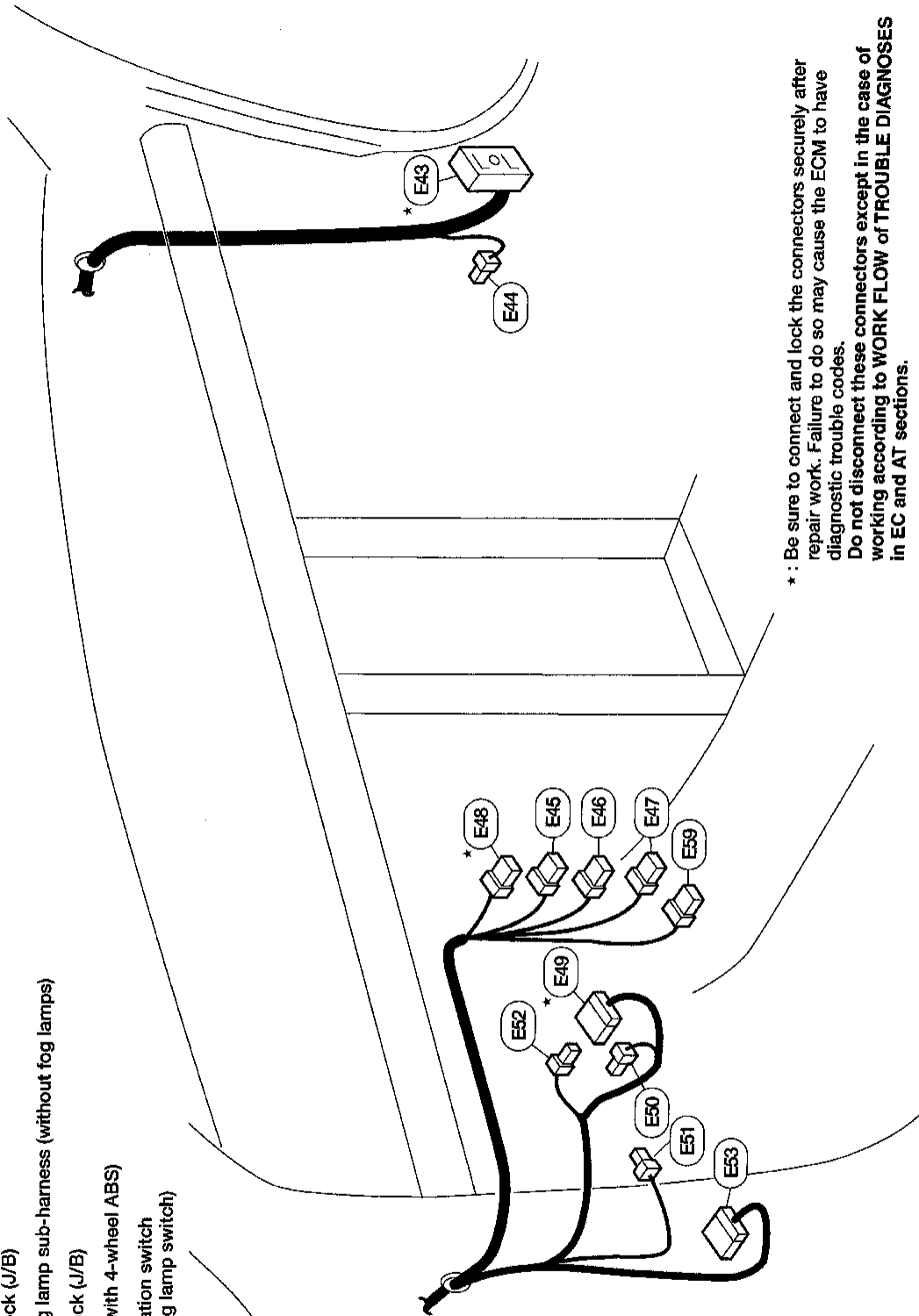

* : Be sure to connect and lock the connectors securely after repair work. Failure to do so may cause the ECM to have diagnostic trouble codes.
 Do not disconnect these connectors except in the case of working according to WORK FLOW of TROUBLE DIAGNOSES in EC and AT sections.

HARNESS LAYOUT

NOTES

GI

MA

EM

LC

EC

FE

CL

MT

AT

TF

PD

FA

RA

BR

ST

RS

BT

HA

EL

IDX

HARNESS LAYOUT

Engine Control Harness

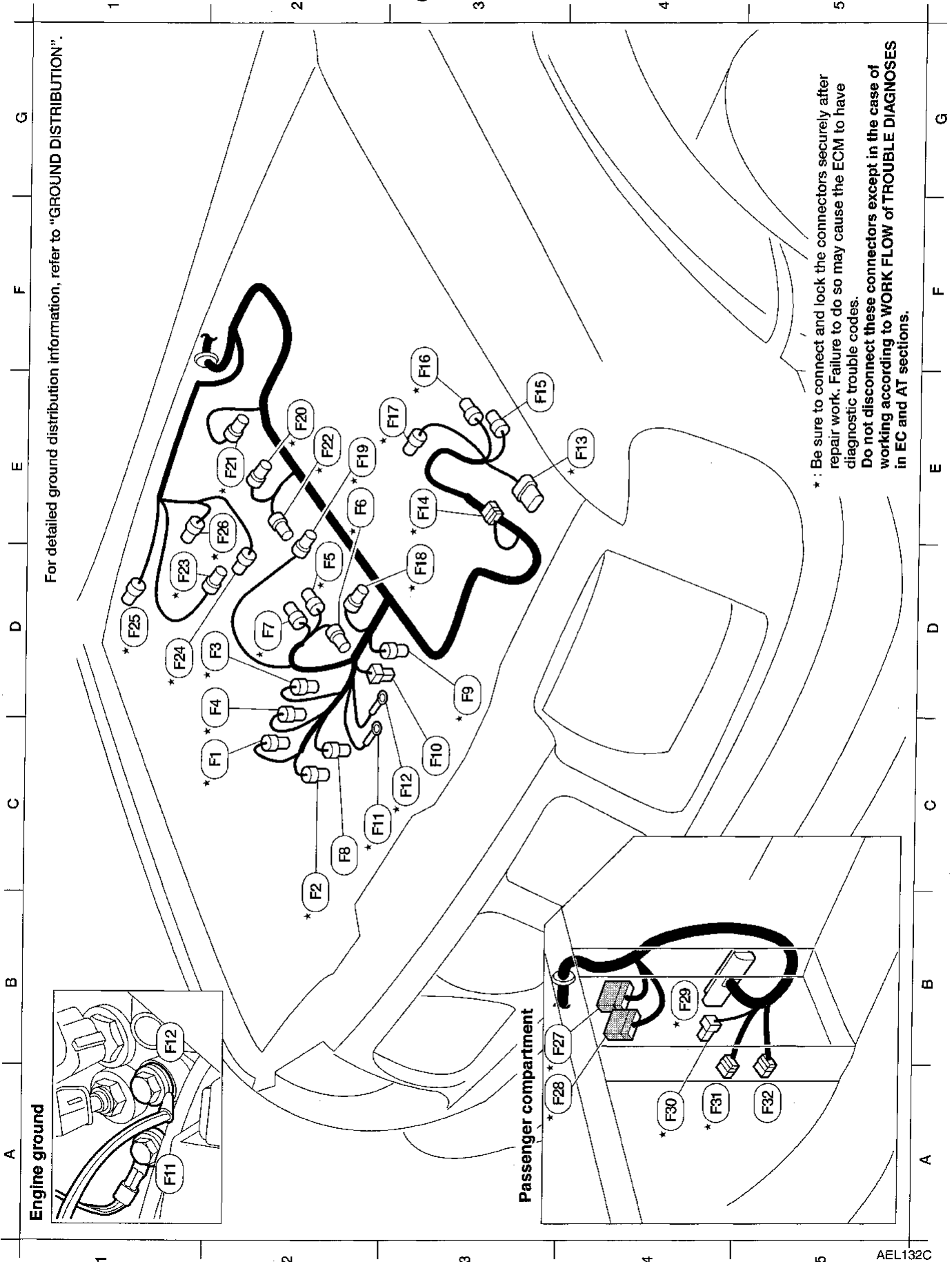

HARNESS LAYOUT

Engine Control Harness (Cont'd)

C2	* (F1) BR/4 : Mass air flow sensor	E3	* (F17) GY/2 : Distributor (ignition coil)
B2	* (F2) GY/2 : Knock sensor	D3	* (F18) B/2 : Injector No. 1
D2	* (F3) BR/3 : Throttle position sensor	E2	* (F18) B/2 : Injector No. 2
D2	* (F4) GY/3 : Throttle position switch	E2	* (F20) B/2 : Injector No. 3
D2	* (F5) GY/2 : EGR temperature sensor	E2	* (F21) B/2 : Injector No. 4
E2	* (F6) BR/2 : IACV-AAC valve	E2	* (F22) G/2 : EGRC-solenoid valve
D2	* (F7) PU/2 : IACV-FICD solenoid valve	D1	* (F23) GY/3 : Absolute pressure sensor
C2	(F8) B/1 : Power steering oil pressure switch	D1	* (F24) B/2 : MAP/BARO switch solenoid valve
D3	* (F9) GY/2 : Engine coolant temperature sensor	D1	* (F25) GY/3 : To (E41)
C3	(F10) B/1 : Thermal transmitter	E2	* (F26) L/2 : EVAP canister purge volume control solenoid valve
C2	* (F11) — : Engine ground	B4	* (F27) W/18 : To (M69)
C3	* (F12) — : Engine ground	A4	* (F28) W/16 : To (M68)
E4	* (F13) GY/6 : Distributor (camshaft position sensor)	B4	* (F29) GY/104 : ECM
E3	* (F14) GY/2 : Resistor	A4	* (F30) L/4 : ECCS relay
E3	(F15) B/1 : A/C compressor	A4	* (F31) GY/6 : Joint connector-1
F3	* (F16) GY/3 : Front heated oxygen sensor	A5	* (F32) GY/6 : Joint connector-2

* : Be sure to connect and lock the connectors securely after repair work. Failure to do so may cause the ECM to have diagnostic trouble codes.
Do not disconnect these connectors except in the case of working according to WORK FLOW of TROUBLE DIAGNOSES in EC and AT sections.

GI

MA

EM

LC

EC

FE

CL

MT

AT

TF

PD

FA

RA

BR

ST

RS

BT

HA

EL

IDX

HARNESS LAYOUT

Engine No. 2 Harness

For detailed ground distribution information, refer to "GROUND DISTRIBUTION".

Engine ground

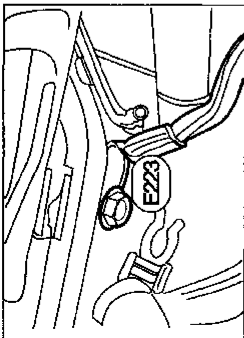

Body ground

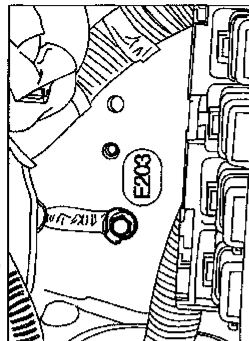

Body ground

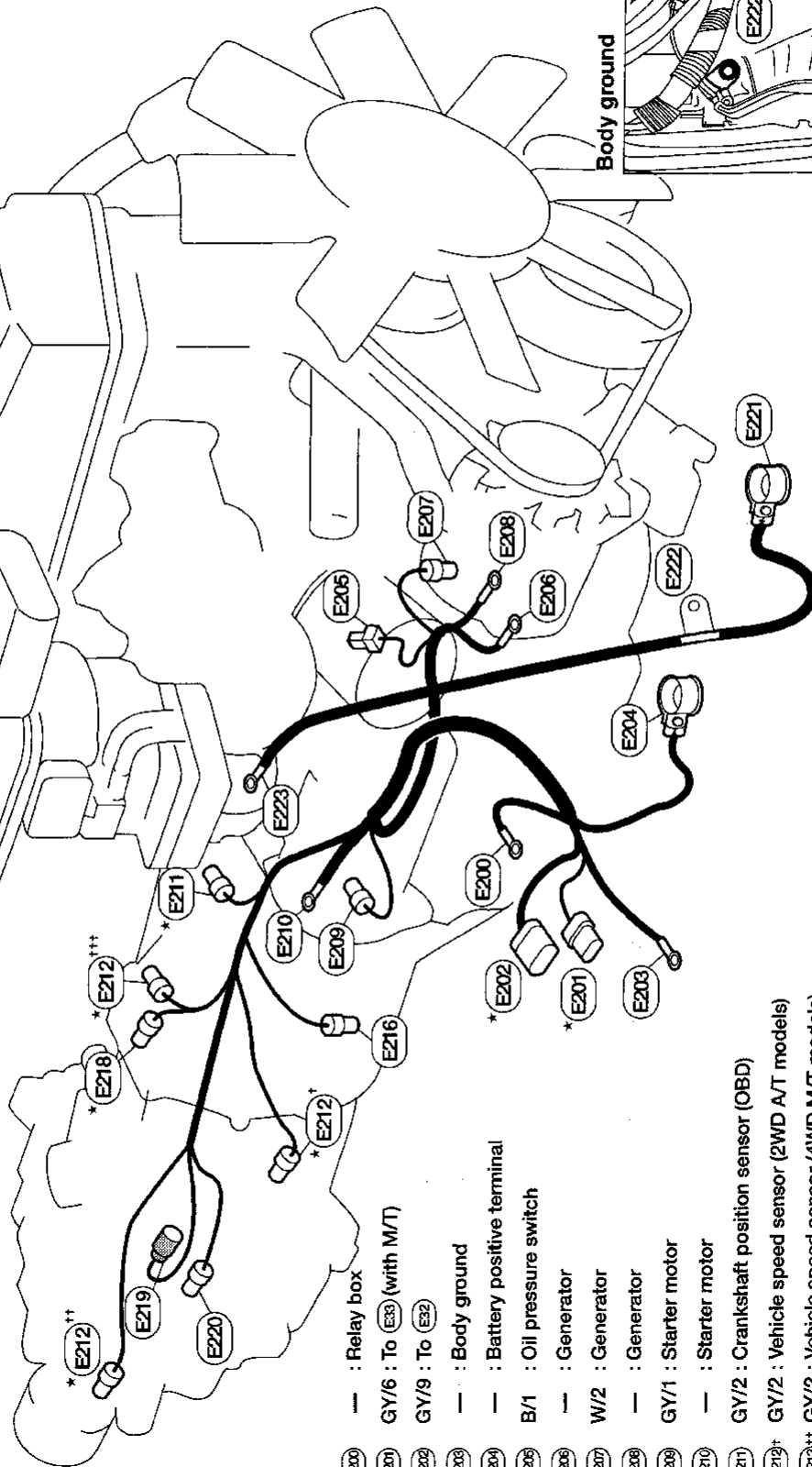
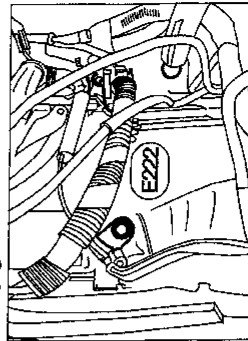

- (E200) — : Relay box
- * (E201) GY/6 : To (E33) (with M/T)
- * (E202) GY/9 : To (E32)
- (E203) — : Body ground
- (E204) — : Battery positive terminal
- (E205) B/1 : Oil pressure switch
- (E206) — : Generator
- (E207) W/2 : Generator
- (E208) — : Generator
- (E209) GY/1 : Starter motor
- (E210) — : Starter motor
- (E211) * (E212)** : Crankshaft position sensor (OBD)
- (E212)*** GY/2 : Vehicle speed sensor (2WD A/T models)
- (E213)** GY/2 : Vehicle speed sensor (4WD M/T models)
- (E214)*** GY/2 : Vehicle speed sensor (2WD M/T models)
- (E215) GY/2 : Back-up lamp switch (with M/T)
- * (E216) B/2 : Park/neutral position (PNP) switch (with M/T)
- (E217) GY/1 : 4WD switch (with 4WD)
- (E218) * (E212)**
- (E219) * (E212)***
- (E220) * (E212)**
- (E221) * (E212)***
- (E222) * (E212)***
- (E223) * (E212)***

* : Be sure to connect and lock the connectors securely after repair work. Failure to do so may cause the ECM to have diagnostic trouble codes.
 Do not disconnect these connectors except to the case of working according to WORK FLOW of TROUBLE DIAGNOSES in EC and AT sections.

- (E203) GY/1 : 4WD switch (with 4WD)
- (E204) — : Battery negative terminal
- (E205) — : Body ground
- (E206) — : Engine ground

HARNES LAYOUT

NOTES

GI

MA

EM

LC

EC

FE

CL

MT

AT

TF

PD

FA

RA

BR

ST

RS

BT

HA

EL

IDX

HARNESS LAYOUT

Chassis and Tail Harness

Chassis Harness

- * C1 W/18 : To (M67)
- * C2 W/8 : To (M17)
- C4 GY/4 : ABS actuator (with 2-wheel ABS)
- * C5 GY/6 : Fuel tank gauge unit
- C6 GY/2 : Rear wheel sensor (with 2-wheel ABS)
- * C7 GY/3 : EVAP control system pressure sensor
- * C8 B/2 : EVAP canister vent control valve
- * C9 G/2 : Vacuum cut valve bypass valve
- C10 GY/6 : To T4
- C11 W/6 : To (M16) (with 4-wheel ABS)
- C12 GY/4 : To C10 (with 4-wheel ABS)
- C10 GY/4 : To C12 (with 4-wheel ABS)
- C10 GY/4 : To rear wheel sensors (with 4-wheel ABS)

Tail Harness

- C1 GY/6 : Rear combination lamp LH
- C2 GY/2 : License plate lamp LH
- C3 GY/2 : License plate lamp RH
- C4 GY/6 : To C10
- C5 GY/6 : Rear combination lamp RH

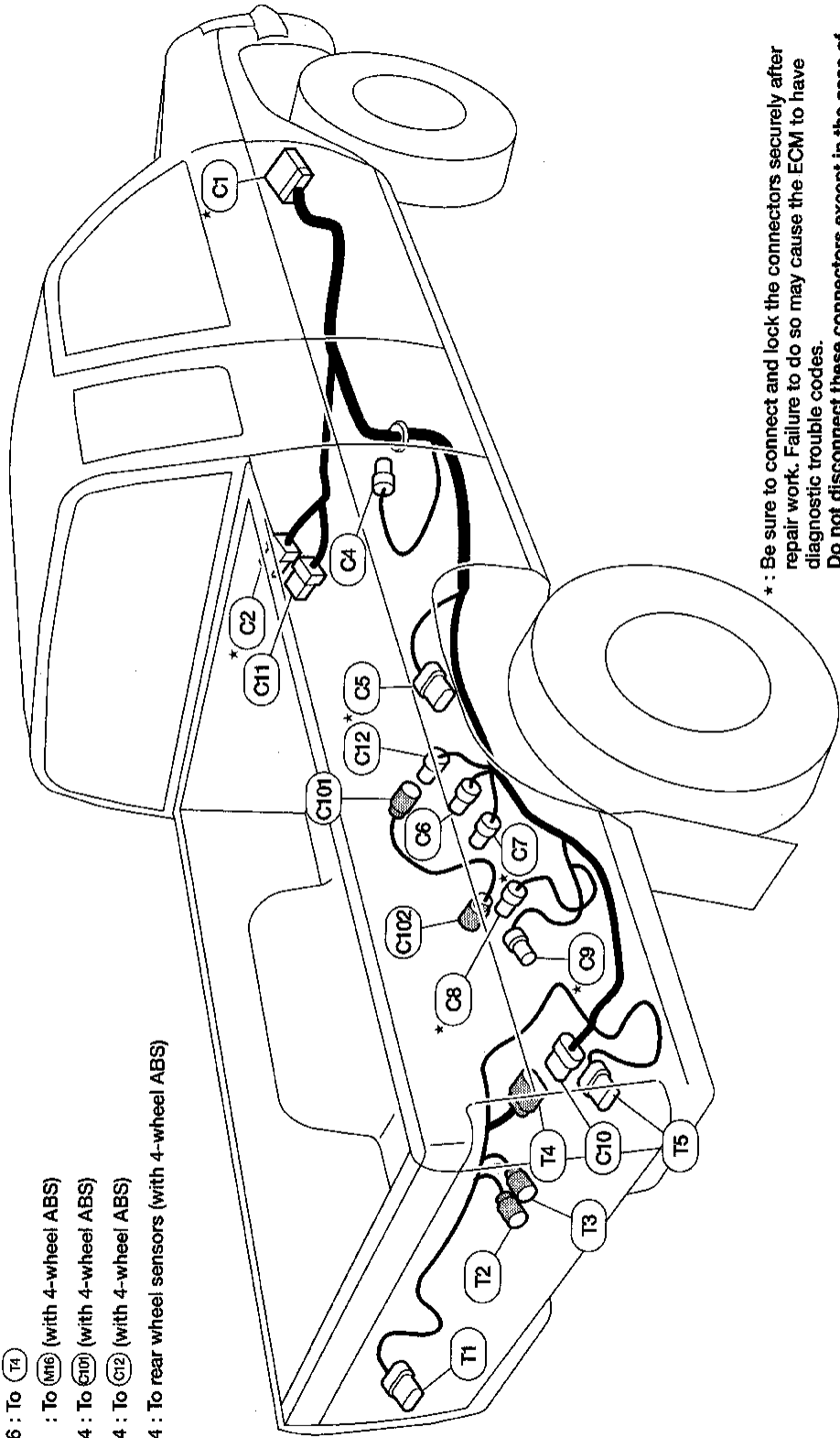

* : Be sure to connect and lock the connectors securely after repair work. Failure to do so may cause the ECM to have diagnostic trouble codes.
Do not disconnect these connectors except in the case of working according to WORK FLOW of TROUBLE DIAGNOSES in EC and AT sections.

HARNES LAYOUT

Room Lamp Harness

- Ⓡ1 W/4 : To Ⓜ2
- Ⓡ2 W/2 : Spot lamp (with spot lamp)
- Ⓡ3 BR/2 : High-mounted stop lamp
- Ⓡ4 W/3 : Room lamp

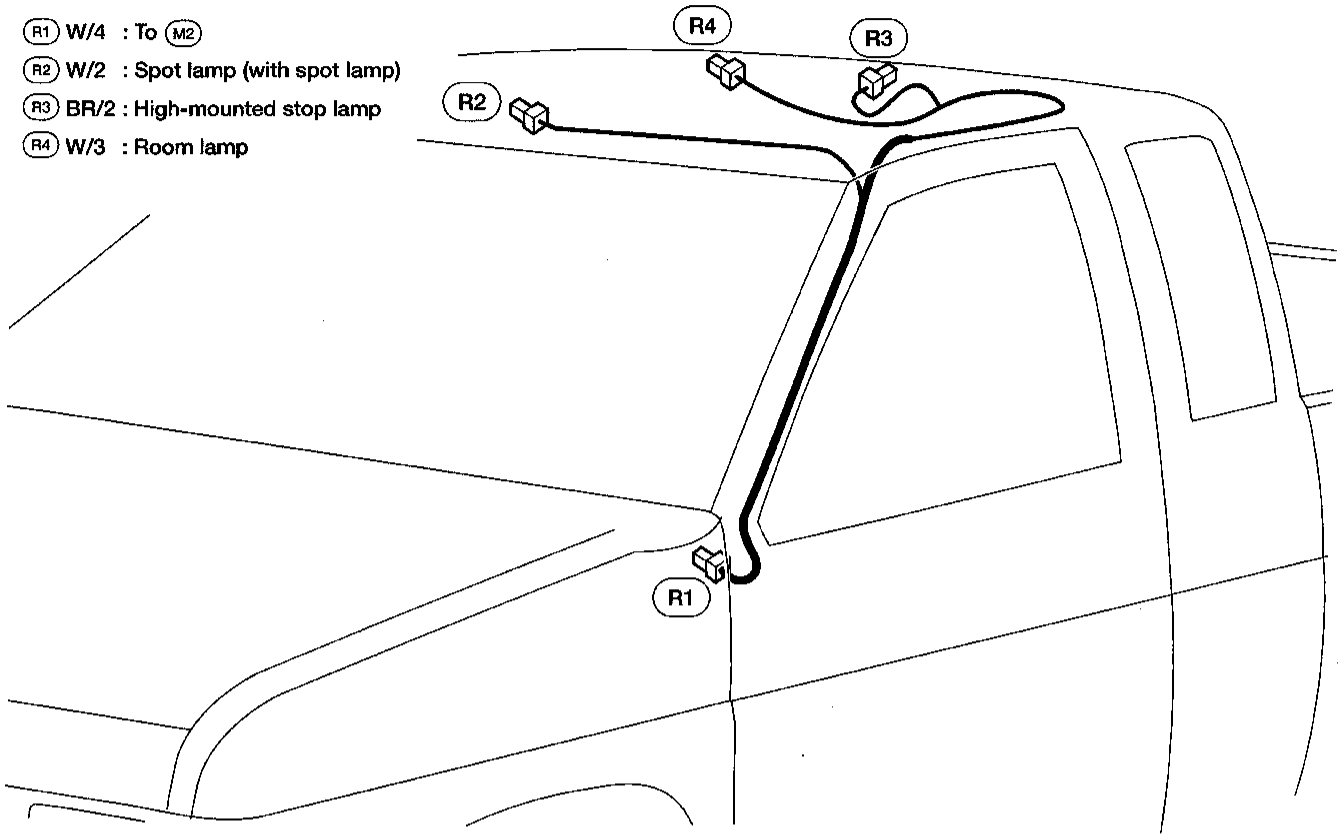

GI
MA
EM
LC
EC
FE
CL
MT
AT
TF
PD
FA
RA
BR
ST
RS
BT
HA
EL
IDX

HARNESS LAYOUT

Door Harness

LH side

- (D1) W/12 : To (M9)
- (D2) W/8 : To (M8)
- (D3) BR/2 : Door speaker LH
- (D4) BR/3 : Door mirror LH (with power mirrors)
- (D5) W/3 : Door tweeter LH
- (D6) B/2 : Power window motor LH (with power windows)
- (D7) GY/12 : Main power window and power door lock/unlock switch (with power windows and door locks)
- (D8) GY/4 : Door lock actuator LH (with power door locks)
- (D9) BR/3 : Door key cylinder switch LH (with power door locks)

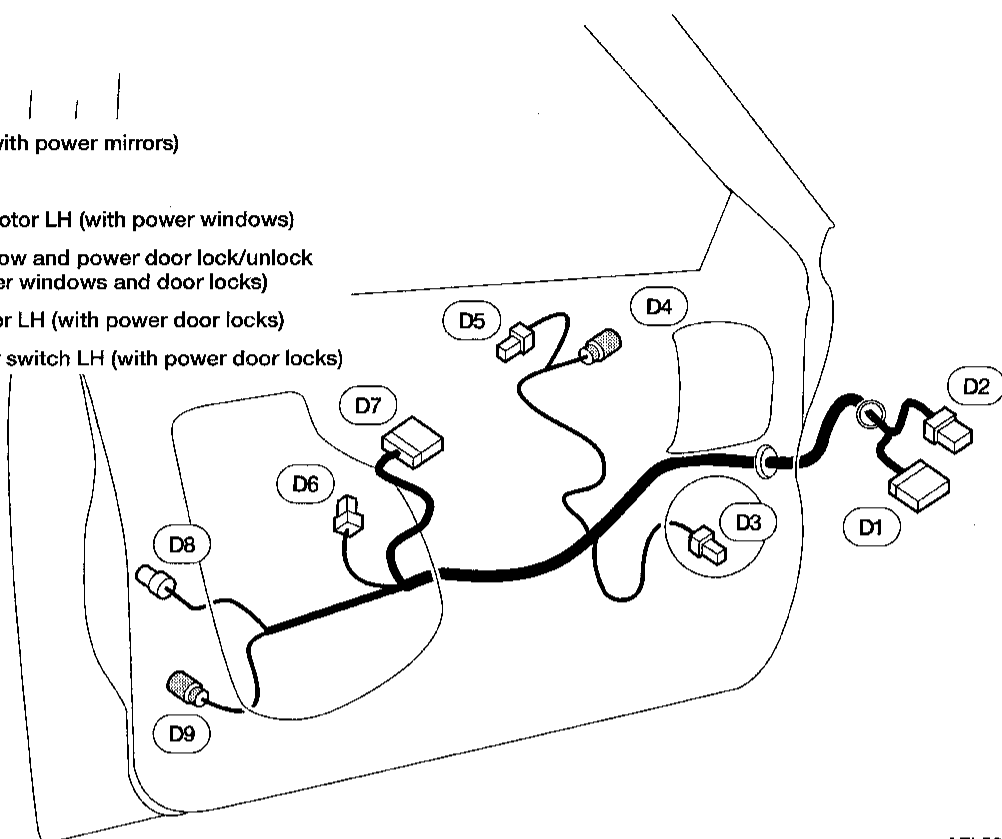

AEL588B

RH side

- (D15) W/12: To (M83)
- (D16) W/6 : To (M64)
- (D17) BR/2 : Door speaker RH
- (D18) BR/3 : Door mirror RH (with power mirrors)
- (D19) W/3 : Door tweeter RH
- (D20) B/2 : Power window motor RH (with power windows)
- (D21) BR/6 : Door lock/unlock switch RH (with power door locks)
- (D22) W/6 : Power window switch RH (with power windows)
- (D23) GY/4 : Door lock actuator RH (with power door locks)
- (D24) BR/3 : Door key cylinder switch RH (with power door locks)

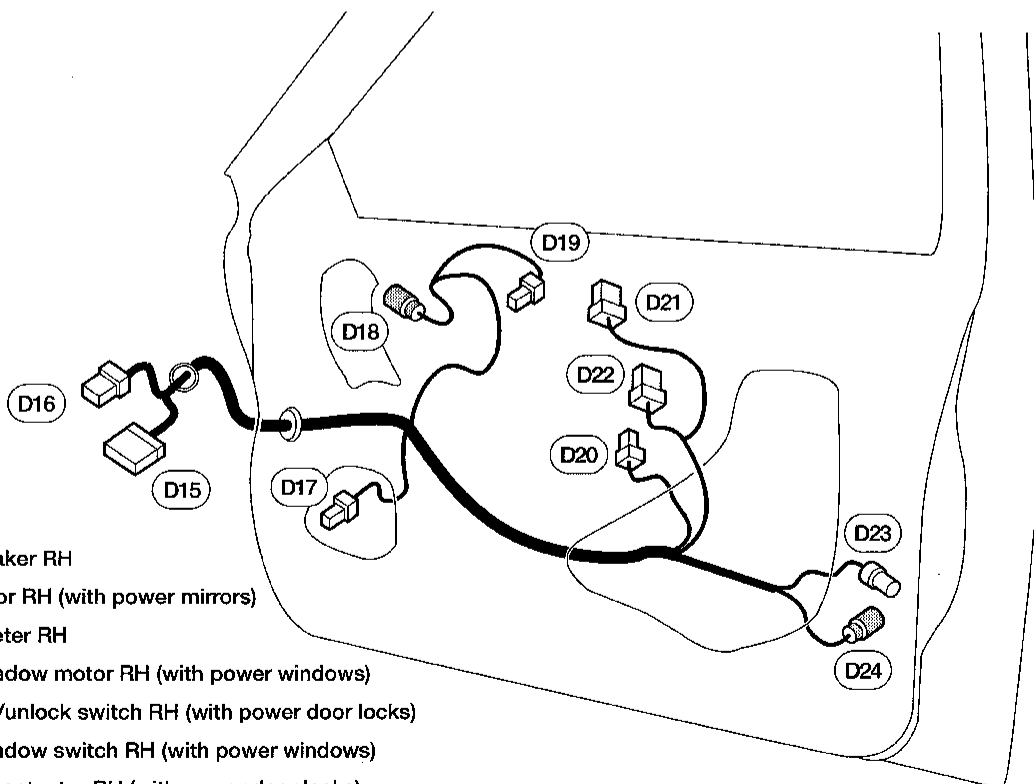

AEL589B

HARNES LAYOUT

Air Bag Harness

- * (Z1) W/4 : To (Z15)
- (Z2) W/2 : Passenger air bag deactivation switch indicator
- (Z3) W/6 : Passenger air bag deactivation switch
- (Z4) B/2 : Passenger air bag module
- (Z5) W/6 : Spiral cable
- (Z6) Y/22 : Air bag diagnosis unit
- (Z7) W/16 : To (M18)
- * (Z15) W/4 : To (Z1)

* : With 4-wheel drive

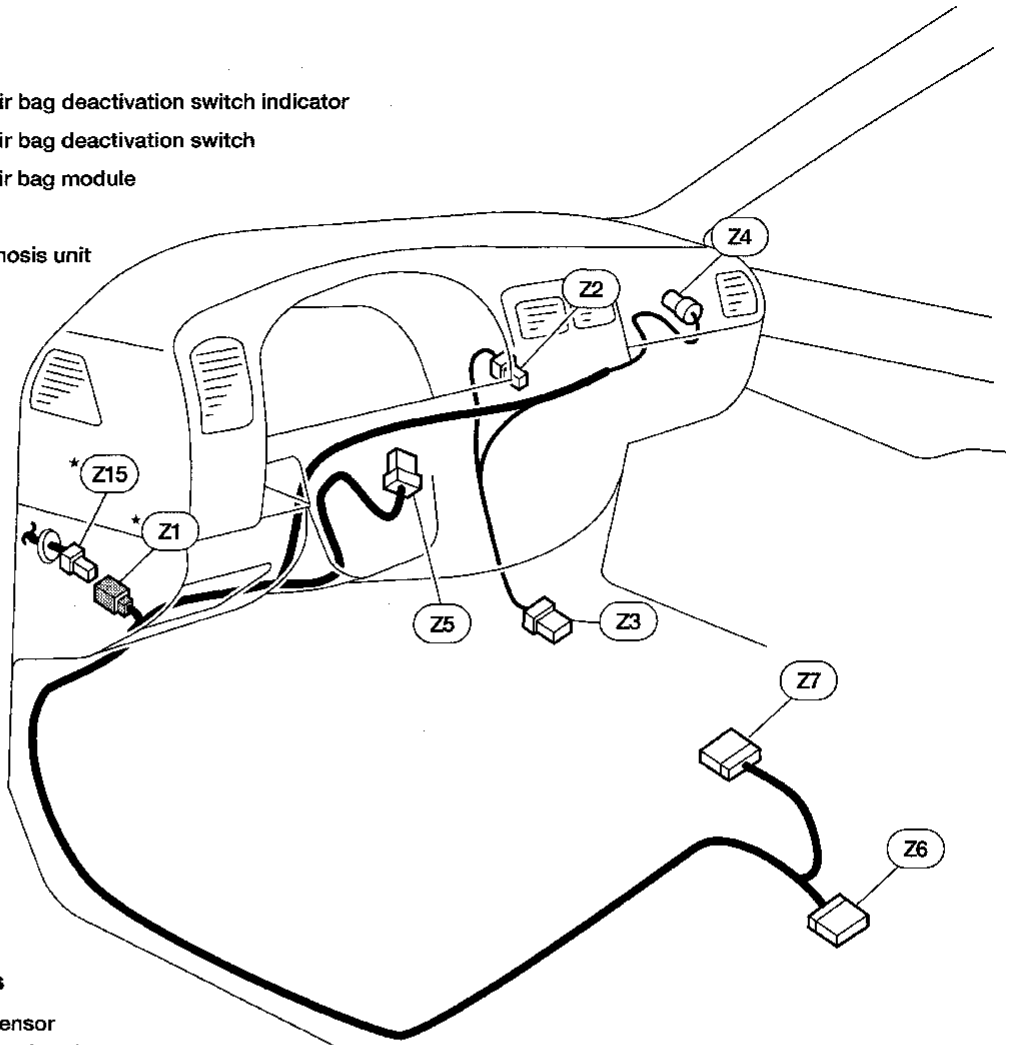

4-wheel drive models

- (Z16) GY/2 : Crash zone sensor

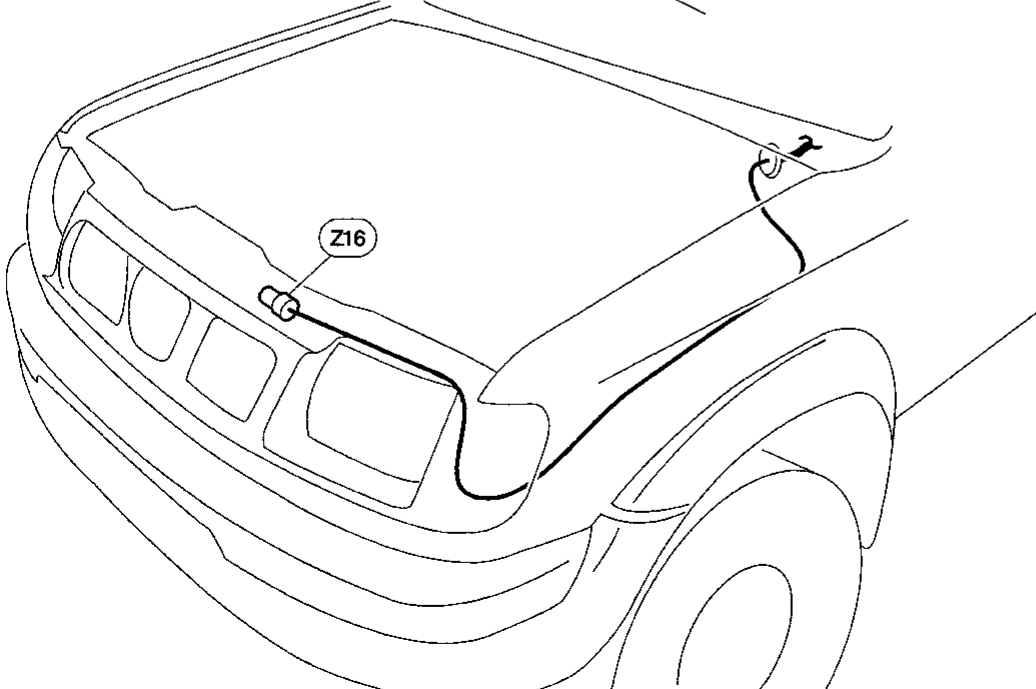

GI
MA
EM
LC
EC
FE
CL
MT
AT
TF
PD
FA
RA
BR
ST
RS
BT
HA
EL
IDX

BULB SPECIFICATIONS

Headlamps

	Wattage (W)
High/low	65/45 (HB1)

Exterior Lamps

	Wattage (W)	
Front combination lamp	27	
Front fog lamp	35 (H3)	
Rear combination lamp	Parking light	3.8
	Turn signal	27
	Stop/Tail	27/7
	Back-up	27
License plate lamp type A (with step bumper)	3.8	
License plate lamp type B (without step bumper)	5	
High mounted stop lamp	2.3	

Interior Lamps

	Wattage (W)
Room lamp (Dome lamp)	10
Spot lamp (Map lamp)	8

WIRING DIAGRAM CODES (CELL CODES)

Use the chart below to find out what each wiring diagram code stands for.

Code	Section	Wiring Diagram Name
A/C	HA	Air Conditioner
A/T	AT	A/T
AAC/V	EC	IACV-AAC Valve
ABS	BR	Anti-Lock Brake System (4WD ABS)
ABS	BR	Anti-Lock Brake System (2WD ABS)
AP/SEN	EC	Absolute Pressure Sensor
ASCD	EL	Automatic Speed Control Device
AT/IND	EL	A/T Indicator Lamp
AUDIO	EL	Audio
BACK/L	EL	Back-up Lamp
BYPS/V	EC	Vacuum Cut Valve Bypass Valve
CHARGE	EL	Charging System
CHIME	EL	Warning Chime
CIGAR	EL	Cigarette Lighter
CKPS	EC	Crank Shaft Position Sensor (OBD)
CMPS	EC	Camshaft Position Sensor
D/LOCK	EL	Power Door Lock
DTRL	EL	Headlamp-With Daytime Light System
ECTS	EC	Engine Coolant Temperature Sensor
EGR/TS	EC	EGR Temperature Sensor
EGRC/V	EC	EGRC-Solenoid Valve
EGRC1	EC	EGR Function
F/FOG	EL	Front Fog Lamp
F/PUMP	EC	Fuel Pump
FICD	EC	IACV-FICD Valve
FRO2	EC	Front Heated Oxygen Sensor
FRO2/H	EC	Front Heated Oxygen Sensor Heater
FUEL	EC	Fuel Injection System Function
H/LAMP	EL	Headlamp
HEATER	HA	Heater System
HORN	EL	Horn
IATS	EC	Intake Air Temperature Sensor
IGN/SG	EC	Ignition Signal
ILL	EL	Illumination
INJECT	EC	Injector
INT/L	EL	Spot Lamp
KS	EC	Knock Sensor

Code	Section	Wiring Diagram Name
LKUP	EC	Torque Converter Clutch Solenoid Valve
MAFS	EC	Mass Air Flow Sensor
MAIN	EC	Main Power Supply and Ground Circuit
METER	EL	Speedometer, Tachometer, Temp. and Fuel Gauges
MIL/DL	EC	MIL and Data Link Connectors
MIRROR	EL	Door Mirror
MULTI	EL	Multi-Remote Control System
PGC/V	EC	EVAP Canister Purge Volume Control Solenoid Valve
PNP/SW	EC	Park/Neutral Position (PNP) Switch
POWER	EL	Power Supply Routing
PRE/SE	EC	Evap Control System Pressure Sensor
PST/SW	EC	Power Steering Oil Pressure Switch
ROOM/L	EL	Interior Room Lamp
RRO2	EC	Rear Heated Oxygen Sensor
RRO2/H	EC	Rear Heated Oxygen Sensor Heater
S/SIG	EC	Start Signal
SHIFT	AT	A/T Shift Lock System
SRS	RS	Supplemental Restraint System
START	EL	Starting System
STOP/L	EL	Stop Lamp
SW/V	EC	MAP/BARO Switch Solenoid Valve
TAIL/L	EL	Parking, License and Tail Lamps
TFTS	EC	Tank Fuel Temperature Sensor
THEFT	EL	Theft Warning System
TP/SW	EC	Throttle Position Switch
TPS	EC	Throttle Position Sensor
TURN	EL	Turn Signal and Hazard Warning Lamps
VENT/V	EC	Evap Canister Vent Control Valve
VSS	EC	Vehicle Speed Sensor
WARN	EL	Warning Lamps
WINDOW	EL	Power Window
WIPER	EL	Wiper and Washer

CI
 MA
 EM
 LC
 EC
 FE
 CL
 MT
 AT
 TF
 PD
 FA
 RA
 BR
 ST
 RS
 BT
 HA
 EL