

### CONTENTS

<b>PRECAUTIONS AND PREPARATION</b> .....	2	Steering Worm Assembly.....	20
Supplemental Restraint System (SRS)		Bearing.....	20
“AIR BAG”.....	2	Oil Seals.....	20
Precautions for Steering System.....	2	<b>POWER STEERING SYSTEM (Model: PB48S)</b> .....	21
Special Service Tools.....	3	Description.....	21
<b>NOISE, VIBRATION AND HARSHNESS (NVH)</b>		<b>POWER STEERING GEAR (Model: PB48S)</b> .....	22
<b>TROUBLESHOOTING</b> .....	5	Removal and Installation.....	22
NVH Troubleshooting Chart.....	5	Steering Gear.....	22
<b>ON-VEHICLE SERVICE</b> .....	6	Power Steering Gear Component.....	22
Steering System.....	6	Pre-disassembly Inspection and Adjustment.....	23
Checking and Adjusting Drive Belts (For power		Turning Torque Measurement.....	23
steering).....	6	Disassembly.....	24
Checking Fluid Level (For power steering).....	6	Adjusting Screw Lock Nut O-Ring.....	24
Checking Fluid Leakage (For power steering).....	7	Sector Shaft Oil Seal.....	24
Bleeding Hydraulic System (For power steering).....	7	Rear Housing O-Ring.....	25
Checking Steering Wheel Turning Force (For		Rear Cover O-Ring And Oil Seal.....	25
power steering).....	8	Assembly.....	26
Checking Steering Wheel Play.....	8	Adjusting Screw Lock Nut O-Ring.....	26
Checking Neutral Position on Steering Wheel.....	9	Sector Shaft Oil Seal.....	26
Checking.....	9	Sector Shaft End Play.....	27
Checking Front Wheel Turning Angle.....	9	Rear Cover O-Ring And Oil Seal.....	27
Checking Hydraulic System (For power steering).....	10	Rear Housing O-Ring.....	27
<b>STEERING WHEEL AND STEERING COLUMN</b> .....	11	Sector Shaft.....	28
Steering Wheel.....	11	<b>POWER STEERING SYSTEM (Model: PB59K)</b> .....	29
Removal And Installation.....	11	Description.....	29
Steering Column.....	12	<b>POWER STEERING GEAR (Model: PB59K)</b> .....	30
Removal.....	12	Removal and Installation.....	30
Installation.....	12	Steering Gear.....	30
Disassembly and Assembly.....	13	Power Steering Gear Component.....	30
Tilt mechanism.....	14	Pre-disassembly Inspection and Adjustment.....	31
Inspection.....	14	Turning Torque Measurement.....	31
<b>MANUAL STEERING GEAR (Model: VB66K)</b> .....	15	Disassembly.....	32
Removal and Installation.....	15	Assembly.....	33
Disassembly.....	16	<b>POWER STEERING OIL PUMP</b> .....	36
Assembly and Adjustment.....	16	Disassembly and Assembly.....	36
Worm Gear Bearing Preload.....	16	Pre-disassembly Inspection.....	36
Sector Shaft End Play.....	18	Inspection.....	37
Steering Gear Preload And Backlash.....	18	Pulley And Pulley Shaft.....	37
Inspection.....	19	Disassembly.....	37
Sector Shaft.....	19	Assembly.....	38

# CONTENTS (Cont'd.)

<b>STEERING LINKAGE</b> .....	39	<b>SERVICE DATA AND SPECIFICATIONS (SDS)</b> .....	42	GI
Removal and Installation .....	39	General Specifications.....	42	MA
Disassembly.....	40	Inspection and Adjustment .....	42	
Idler Arm Assembly .....	40	Steering Column Length .....	42	EM
Cross Rod And Tie-Rod .....	40	Manual Steering Gear .....		
Inspection.....	41	(Model: VB66K).....	43	
Ball Joint And Swivel Joint.....	41	Steering Linkage .....	43	LC
Idler Arm Assembly .....	41	Power Steering System .....		
Cross Rod And Tie-Rod .....	41	(Model: PB48S).....	43	
Fixing Location .....	41	Power Steering System .....		
		(Model: PB59K).....	44	EC
				FE
				CL
				MT
				AT
				TF
				PD
				FA
				RA
				BR
				<b>ST</b>
				RS
				BT
				HA
				EL
				IDX

### Supplemental Restraint System (SRS) “AIR BAG”

The Supplemental Restraint System “AIR BAG”, used along with a seat belt, helps to reduce the risk or severity of injury to the driver and front passenger in a frontal collision. The Supplemental Restraint System consists of air bag modules (located in the center of the steering wheel and on the instrument panel on the passenger side), a diagnosis sensor unit, a crash zone sensor (4WD models), warning lamp, wiring harness and spiral cable.

The vehicle is equipped with an passenger air bag deactivation switch. Because no rear seat exists where a rear-facing child restraint can be placed, the switch is designed to turn off the passenger air bag so that a rear-facing child restraint can be used in the front passenger seat. The switch is located in the center of the instrument panel, near the ashtray. When the switch is turned to the ON position, the passenger air bag is enabled and could inflate in a frontal collision. When the switch is turned to the OFF position, the passenger air bag is disabled and will not inflate in a frontal collision. A passenger air bag OFF indicator on the instrument panel lights up when the passenger air bag is switched OFF. The driver air bag always remains enabled and is not affected by the passenger air bag deactivation switch.

Information necessary to service the system safely is included in the **RS section** of this Service Manual.

#### **WARNING:**

- **To avoid rendering the SRS inoperative, which could increase the risk of personal injury or death in the event of a collision which would result in air bag inflation, all maintenance should be performed by an authorized NISSAN dealer.**
- **Improper maintenance, including incorrect removal and installation of the SRS, can lead to personal injury caused by unintentional activation of the system.**
- **Do not use electrical test equipment on any circuit related to the SRS unless instructed to in this Service Manual. SRS wiring harnesses are covered with yellow insulation either just before the harness connectors or on the complete harness, for easy identification.**
- **The vehicle is equipped with a passenger air bag deactivation switch which can be operated by the customer. When the front passenger air bag is switched OFF, the front passenger air bag is disabled and will not inflate in a frontal collision. When the front passenger air bag is switched ON, the front passenger air bag is enabled and could inflate in a frontal collision. After SRS maintenance or repair, make sure the front passenger air bag switch is in the same position (ON or OFF) as when the vehicle arrived for service.**

### Precautions for Steering System

- **Before disassembly, thoroughly clean the outside of the unit.**
- **Disassembly should be done in a clean work area. It is important to prevent the internal parts from becoming contaminated by dirt or other foreign matter.**
- **For easier and proper assembly, place disassembled parts in order on a parts rack.**
- **Use nylon cloths or paper towels to clean the parts; common shop rags can leave lint that might interfere with their operation.**
- **Before inspection or reassembly, carefully clean all parts with a general purpose, non-flammable solvent.**
- **Before assembly, apply a coat of recommended ATF\* to hydraulic parts. Petroleum jelly may be applied to O-rings and seals. Do not use any grease.**
- **Replace all gaskets, seals and O-rings. Avoid damaging O-rings, seals and gaskets during installation. Perform functional tests whenever designated.**

\*: Automatic Transmission Fluid type DEXRON™ III or equivalent.

# PRECAUTIONS AND PREPARATION

## Special Service Tools

The actual shape of Kent-Moore tools may differ from those of special service tools illustrated here.

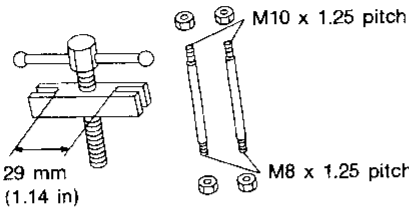
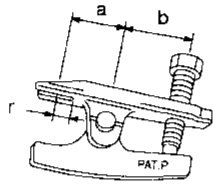
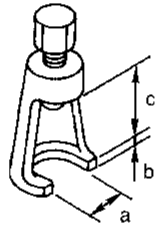
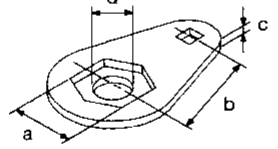
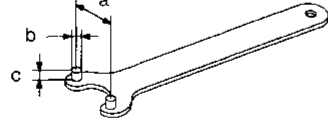
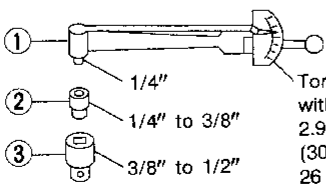
Tool number (Kent-Moore No.) Tool name	Description	Unit application		
		Manual steering	Power steering	
ST27180001 (J25726-A) Steering wheel puller	 <p>NT544</p>	Removing steering wheel	X	X
HT72520000 (J25730-B) Ball joint remover	 <p>NT546</p>	Removing ball joint and swivel joint	X	X
ST29020001 (J24319-01) Steering gear arm puller	 <p>NT694</p>	Removing pitman arm	X	X
KV48101500 (J28802) Lock nut wrench	 <p>NT534</p>	Removing and installing lock nut	X	—
KV48101400 (J28803) Adjusting plug wrench	 <p>NT539</p>	Adjusting and tightening lock nut	X	—
ST3127S000 (see J25765-A) ① GG91030000 (J25765-A) Torque wrench ② HT62940000 ( — ) Socket adapter ③ HT62900000 ( — ) Socket adapter	 <p>NT541</p>	Measuring turning torque	X	X

GI

MA

EM

LC

EC

FE

CL

MT

AT

TF

PD

FA

RA

BR

ST

RS

BT



HA

EL

IDX

# PRECAUTIONS AND PREPARATION

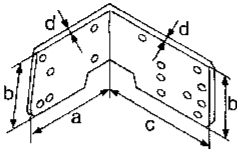
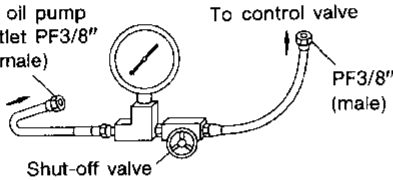
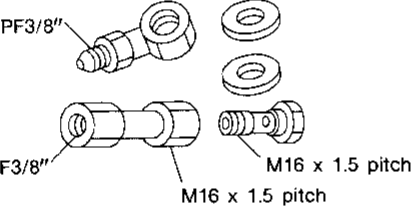
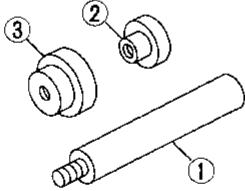
## Special Service Tools (Cont'd)

Tool number (Kent-Moore No.) Tool name	Description	Unit application	
		Manual steering	Power steering
KV48100301 ( — ) Strut & steering gearbox attachment	 <p style="text-align: right;">Steering gear is installed.</p> <p style="text-align: right;">a: 162 mm (6.38 in) b: 110 mm (4.33 in) c: 190 mm (7.48 in) d: 9 mm (0.35 in)</p>	X	X
NT688			
KV48103500 (J26357 or J26357-10) Pressure gauge		—	X
NT547			
KV48102500 ( — ) Pressure gauge adapter		—	X
NT542			
KV481009S0 ( — ) Oil seal drift set ① KV48100910 ( — ) Drift ② KV48100920 (J26367) Adapter ③ KV48100930 (J26367) Adapter		—	X
NT174			
KV48100700 (J26364) Torque adapter		X	X
NT169			



Steering System

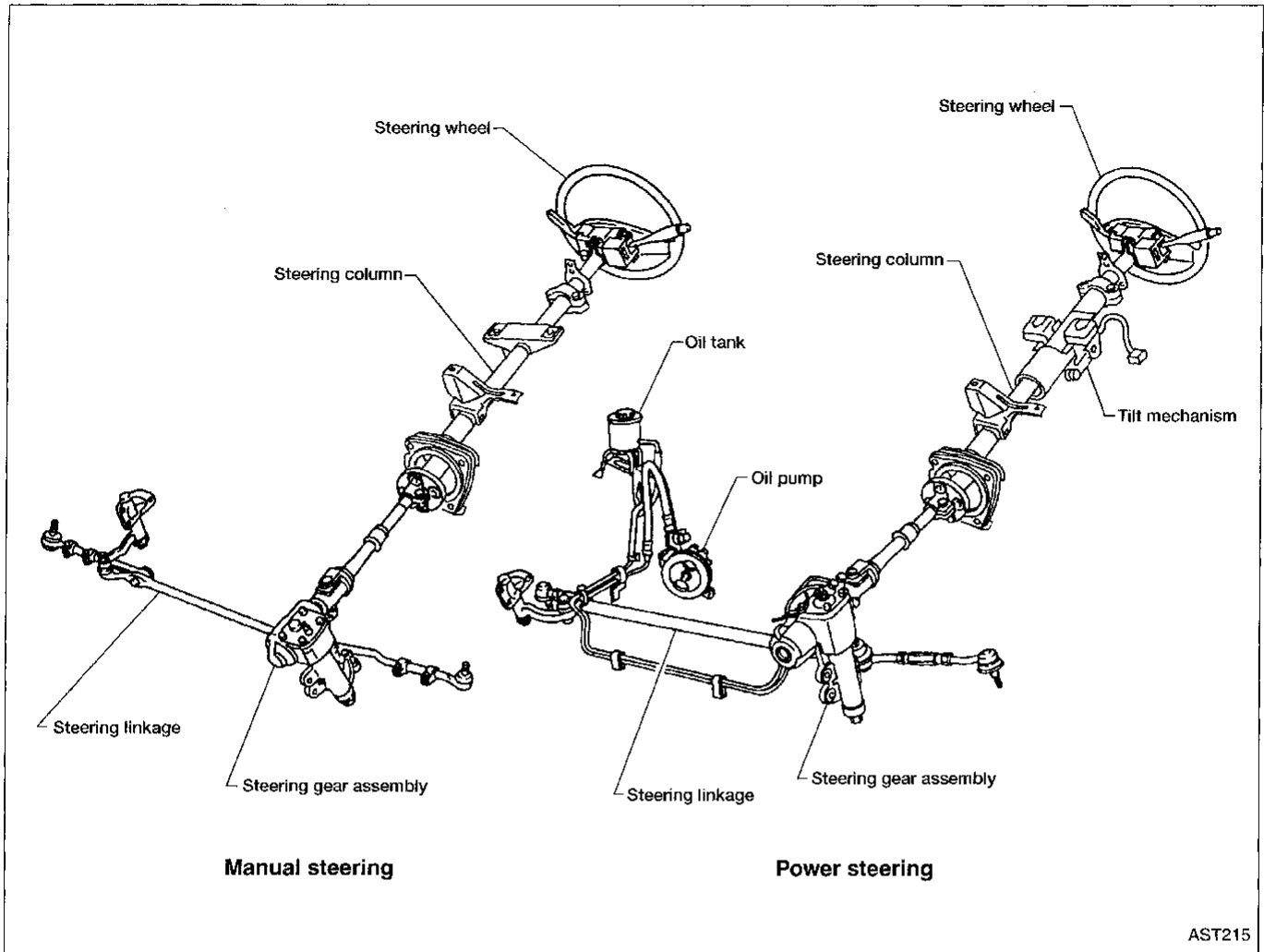

AST215

Checking and Adjusting Drive Belts (For power steering)

Refer to MA section ("Checking Drive Belts", "ENGINE MAINTENANCE").

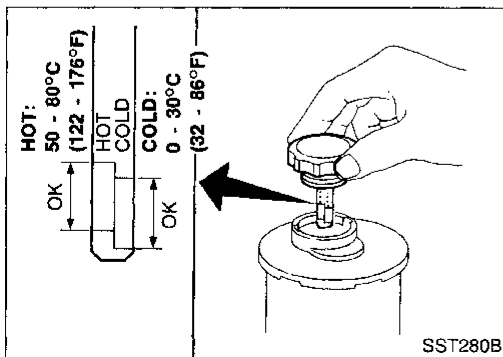

SST280B

Checking Fluid Level (For power steering)

Check fluid level with engine off.

Check fluid level with dipstick on reservoir cap.

Use "HOT" range for fluid temperatures of 50 to 80°C (122 to 176°F). Use "COLD" range for fluid temperatures of 0 to 30°C (32 to 86°F).

CAUTION:

- Do not overfill.
- Recommended fluid is Automatic Transmission Fluid type DEXRON™ III or equivalent.

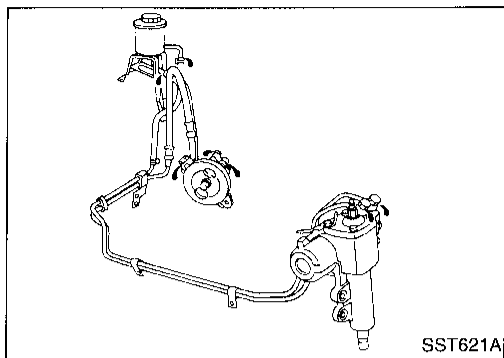

## Checking Fluid Leakage (For power steering)

Check lines for improper attachment, leaks, cracks, damage, chafing and deterioration.

1. Run engine between idle speed and 1,000 rpm.
  - **Make sure temperature of fluid in reservoir tank rises to 60 to 80°C (140 to 176°F).**
2. Turn steering wheel right-to-left several times.
3. Hold steering wheel at each "lock" position for 5 seconds and carefully check for fluid leakage.

### CAUTION:

**Do not hold steering wheel at lock position for more than 15 seconds.**

4. If fluid leakage from any line is noticed, loosen flare nut and then retighten.

**Do not overtighten connector as this can damage O-ring, washer and connector.**

5. If fluid leakage from power steering pump is noticed, check power steering pump. Refer to ST-36.
6. If fluid leakage from power steering gear is noticed, check power steering gear. Refer to ST-21 (PB48S), or ST-29 (PB59K).

## Bleeding Hydraulic System (For power steering)

1. Raise front end of vehicle until wheels are clear of the ground.
2. Add fluid to reservoir tank to specified level. Then quickly turn steering wheel fully to right and left and lightly touch steering stoppers.

Repeat steering wheel operation until fluid level no longer decreases.

3. Start engine.
  - Repeat step 2 above.
  - Incomplete air bleeding will cause the following to occur:
    - a. Air bubbles in reservoir tank
    - b. Clicking noise in power steering pump
    - c. Excessive buzzing in power steering pump
 When this happens, bleed air again.

Fluid noise may occur in the valve or power steering pump. This is common when the vehicle is stationary or while turning the steering wheel slowly. This does not affect the performance or durability of the system.

GI

MA

EM

LC

EC

FE

CL

MT

AT

TF

PD

FA

RA

BR

ST

RS

BT

HA

EL

IDX



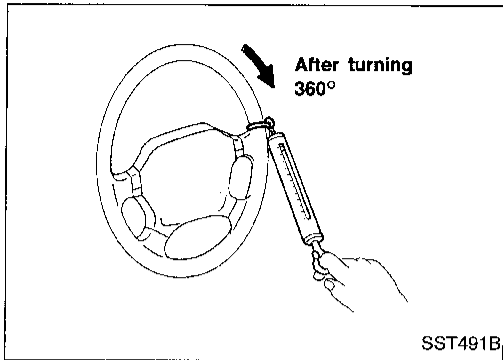

## Checking Steering Wheel Turning Force (For power steering)

1. Park vehicle on a level, dry surface and set parking brake.
2. Start engine and run at idle speed or 1,000 rpm.
3. Bring power steering fluid up to adequate operating temperature. [Make sure temperature of fluid is approximately 60 to 80°C (140 to 176°F).]

**Tires need to be inflated to normal pressure.**

4. Check steering wheel turning force when steering wheel has been turned 360° from neutral position.

**Steering wheel turning force:**

**PB48S-type**

**24.5 - 29.4 N (2.5 - 3.0 kg, 5.5 - 6.6 lb)**

**PB59K-type**

**39 N (4 kg, 9 lb) or less**

5. If steering wheel turning force is out of specification, check the following:
  - a. Hydraulic system. Refer to "Checking Hydraulic System", ST-10.
  - b. Steering Column. Refer to ST-12.
  - c. Front suspension and axle. Refer to FA section ("Front Axle and Front Suspension Parts", "ON-VEHICLE SERVICE").
  - d. Steering gear turning torque. Refer to "TURNING TORQUE MEASUREMENT", ST-23 (PB48S), or ST-31 (PB59K).

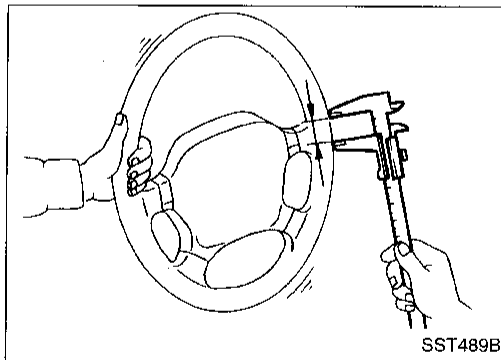

## Checking Steering Wheel Play

- Place wheels in straight ahead position and check steering wheel play.

**Steering wheel play:**

**35 mm (1.38 in) or less**

- If it is not within specification, check the following for loose or worn components.
  - a. Steering column. Refer to ST-12.
  - b. Front suspension and axle. Refer to FA section ("Front Axle and Front Suspension Parts", "ON-VEHICLE SERVICE").
  - c. Steering gear. [Refer to ST-15 (manual steering), ST-21 (power steering PB48S), or ST-29 (power steering PB59K).]

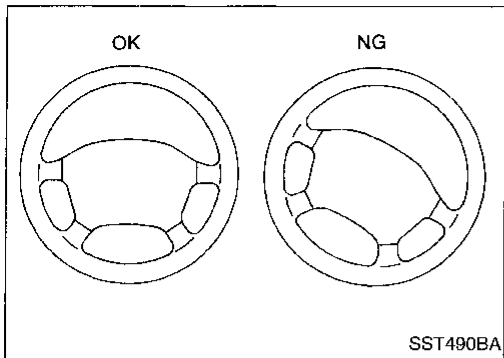

## Checking Neutral Position on Steering Wheel

- Make sure that wheel alignment is correct.

### Wheel alignment:

Refer to FA section (“Inspection and Adjustment”, “SERVICE DATA AND SPECIFICATIONS”).

- Verify that the steering gear is centered before removing the steering wheel.

### Checking

1. Check that the steering wheel is in the neutral position when driving straight ahead.
2. If it is not in the neutral position, remove the steering wheel and reinstall it correctly.
3. If the neutral position is still not correct:
  - a. Loosen tie-rod lock nuts.
  - b. Move tie-rods, in opposite direction, the same amount on both left and right sides.  
This will compensate for error in the neutral position.

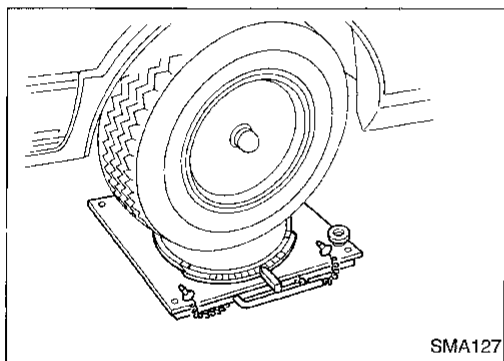

## Checking Front Wheel Turning Angle

1. Rotate steering wheel fully right, then left; measure turning angle.

### Turning angle of full turns:

Refer to FA section (“Inspection and Adjustment”, “SERVICE DATA AND SPECIFICATIONS”).

2. If it is not within specification, check stopper bolt adjustment. Refer to FA section (“FRONT WHEEL TURNING ANGLE”, “Front Wheel Alignment”).

GI

MA

EM

LC

EC

FE

CL

MT

AT

TF

PD

FA

RA

BR

ST

RS

BT

HA

EL

IDX

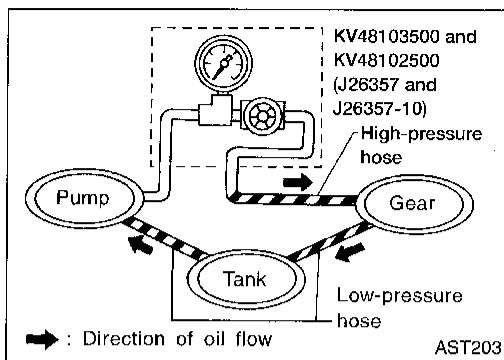

## Checking Hydraulic System (For power steering)

Before starting, check belt tension, driving pulley and tire pressure.

1. Set Tool. Open shut-off valve. Then bleed air. Refer to "Bleeding Hydraulic System", ST-7.
2. Run engine at idle speed or 1,000 rpm.
  - **Make sure fluid temperature in reservoir tank rises to 60 to 80°C (140 to 176°F).**

### WARNING:

**Warm up engine with shut-off valve fully opened. If engine is started with shut-off valve closed, fluid pressure in the power steering pump increases to maximum. This will raise fluid temperature abnormally.**

3. Check pressure with steering wheel fully turned to left and right positions while idling at 1,000 rpm.

### CAUTION:

**Do not hold the steering wheel at full lock position for more than 15 seconds.**

**Power steering pump maximum operating pressure:  
7,649 - 8,238 kPa (76.5 - 82.4 bar, 78 - 84 kg/cm<sup>2</sup>,  
1,109 - 1,194 psi) at idling**

- If pressure reaches maximum operating pressure, system is OK.
  - If pressure increases above maximum operating pressure, check power steering pump flow control valve. Refer to ST-36.
4. If power steering pressure is below the maximum operating pressure, slowly close shut-off valve and check pressure again.

### CAUTION:

**Do not close shut-off valve for more than 15 seconds.**

- If pressure increases to maximum operating pressure, gear is damaged. Refer to "Removal and Installation", ST-22, 30.
  - If pressure remains below maximum operating pressure, pump is damaged. Refer to "Disassembly and Assembly", ST-36.
5. After checking hydraulic system, remove Tool and add fluid as necessary. Then completely bleed air out of system. Refer to ST-7.

# STEERING WHEEL AND STEERING COLUMN

SEC. 253 • 484 • 487 • 488 • 680

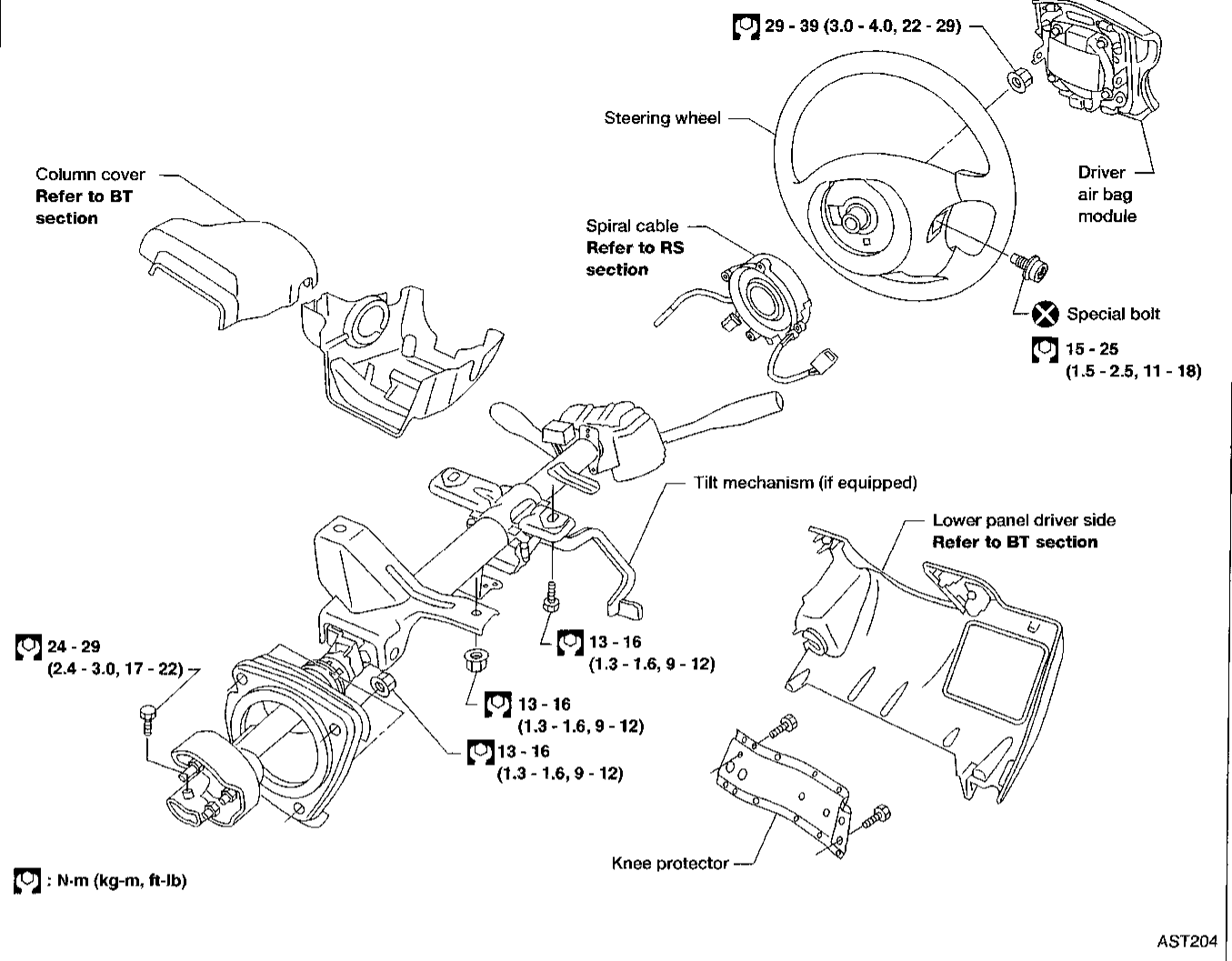

GI  
MA  
EM  
LC  
EC  
FE  
CL  
MT  
AT  
TF  
PD  
FA  
RA  
BR  
ST  
RS  
BT  
HA  
EL  
IDX

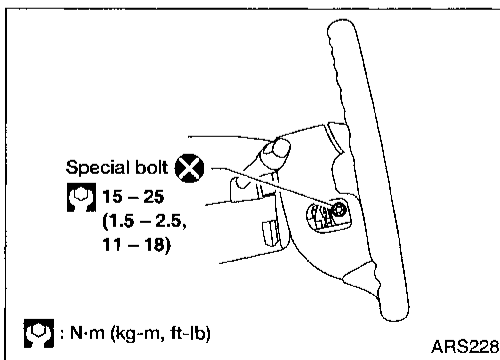

## Steering Wheel

### REMOVAL AND INSTALLATION

1. Remove air bag module and spiral cable. Refer to RS section ["Air Bag Module and Spiral Cable", "SUPPLEMENTAL RESTRAINT SYSTEM (SRS)"].
2. Disconnect horn connector and remove steering wheel nut.

# STEERING WHEEL AND STEERING COLUMN

## Steering Wheel (Cont'd)

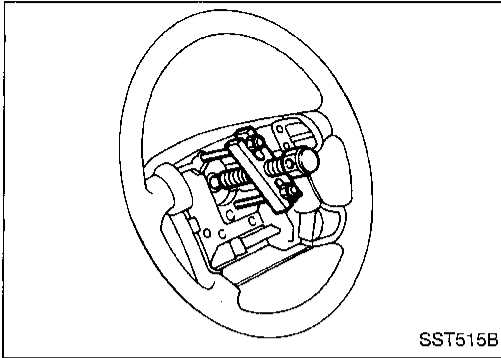

3. Remove steering wheel using Tool.
  - For installation, refer to RS section ["Air Bag Module and Spiral Cable", "SUPPLEMENTAL RESTRAINT SYSTEM (SRS)"].

## Steering Column

### REMOVAL

#### CAUTION:

- The rotation of the spiral cable (SRS "Air bag" component part) is limited. If the steering gear must be removed, set the front wheels in the straight-ahead direction. Do not rotate the steering column while the steering gear is removed.
- Remove the steering wheel before removing the steering lower joint to avoid damaging the SRS spiral cable. Refer to ST-11.

1. Remove steering wheel, refer to ST-11.
2. Remove steering column covers.
3. Remove instrument lower panel. Disconnect security lamp indicator.
4. Disconnect combination switch electrical connectors and air bag harness connector.
5. Remove knee protector.
6. Disconnect ignition switch and shift lock solenoid connectors.
7. Disconnect shift cable.
8. Remove bolt from lower joint.
9. Remove two steering column bolts and remove steering column.

### INSTALLATION

- When installing steering column, finger-tighten all lower bracket and clamp retaining bolts; then tighten them securely. Make sure that undue stress is not applied to steering column.
- When fitting steering lower joint, be sure tightening bolt faces cutout portion.
- Align spiral cable correctly when installing steering wheel. Refer to RS section ["Air Bag Module and Spiral Cable", "SUPPLEMENTAL RESTRAINT SYSTEM (SRS)"].

#### CAUTION:

After installation, turn steering wheel to make sure it moves smoothly. Ensure the number of turns from the straight forward position to left and right locks are the same. Be sure that the steering wheel is in a neutral position when driving straight ahead.

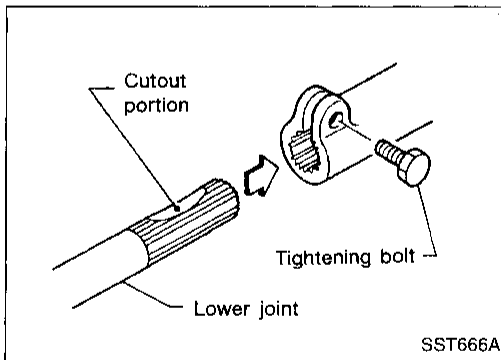

# STEERING WHEEL AND STEERING COLUMN

## Disassembly and Assembly

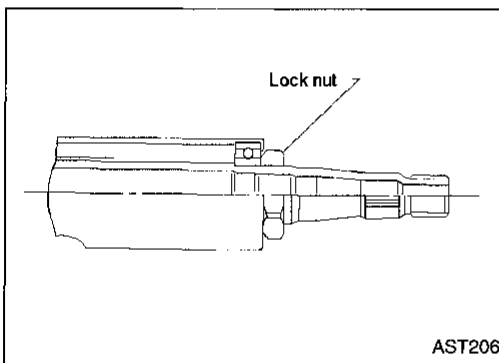
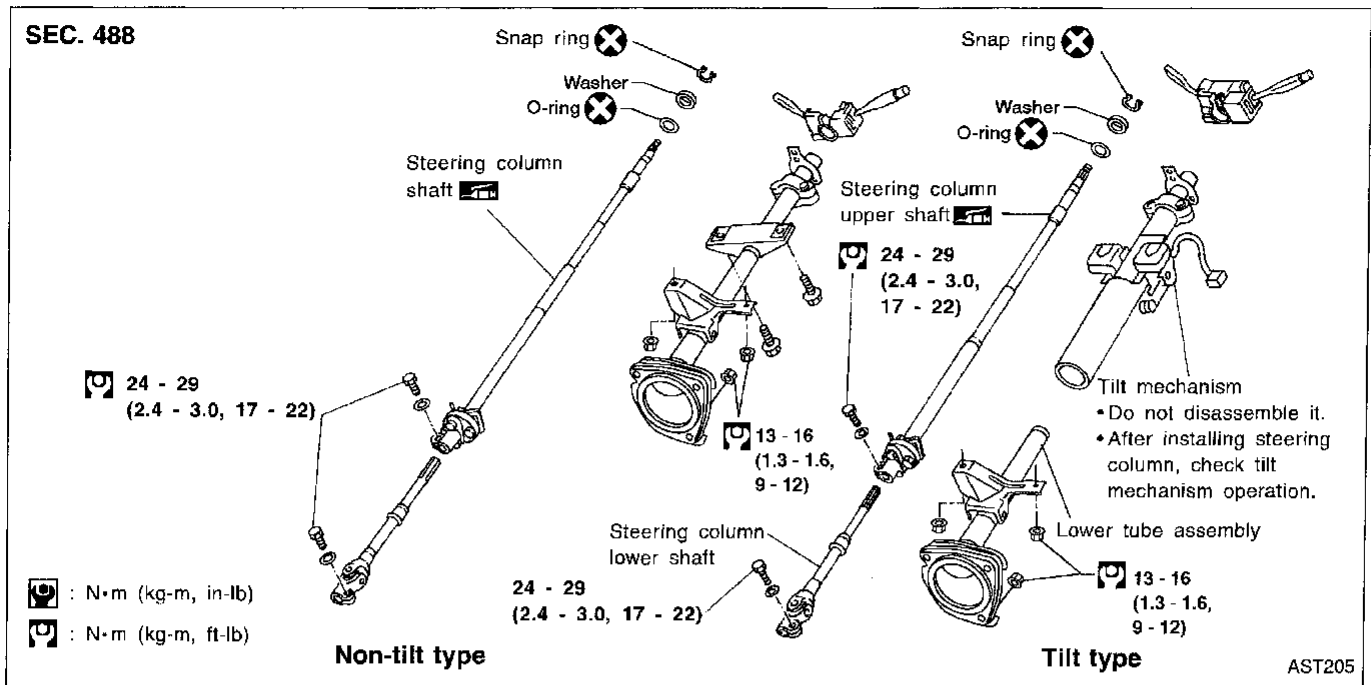

- When disassembling and assembling, unlock steering lock with key.
- Install lock nut on steering column shaft and tighten the nut to specification.

: 25 - 34 N·m (2.5 - 3.5 kg-m, 18 - 25 ft. lb)

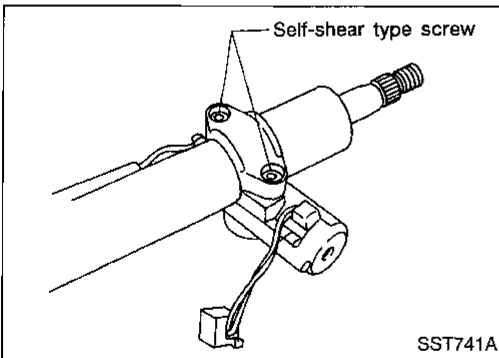

- Steering lock
  - Break self-shear type screws using a drill or other appropriate tool.

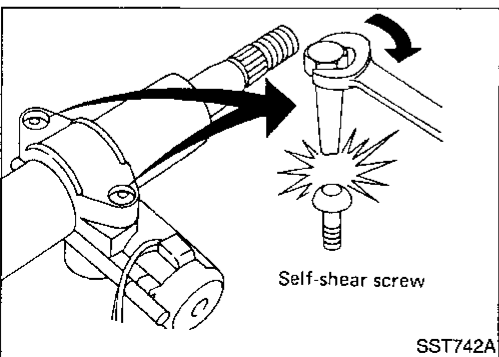

- Install self-shear type screws, then tighten until heads break off.

# STEERING WHEEL AND STEERING COLUMN

## Disassembly and Assembly (Cont'd)

### Tilt mechanism

After installing steering column, check tilt mechanism operation.

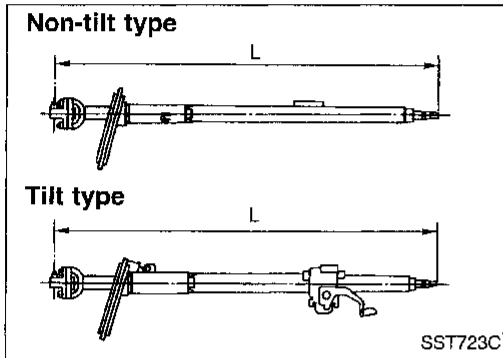
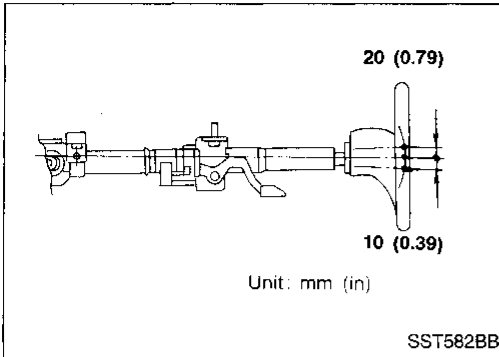

### Inspection

- When steering wheel does not turn smoothly, check the steering column as follows and replace damaged parts.
  - a. Check column bearings for damage and unevenness. Lubricate with recommended multi-purpose grease or replace steering column as an assembly, if necessary.
  - b. Check jacket tube for deformation and breakage. Replace if necessary.
- When the vehicle is involved in a light collision, check dimension "L". If it is not within specifications, replace steering column as an assembly.

**Column length "L":**

**863.1 - 866.7 mm (33.98 - 34.12 in)**

## Removal and Installation

CI  
MA  
EM  
LC  
EC  
FE  
CL  
MT  
AT  
TF  
PD  
FA  
RA  
BR  
ST  
RS  
BT  
HA  
EL  
IDX

### SEC. 480

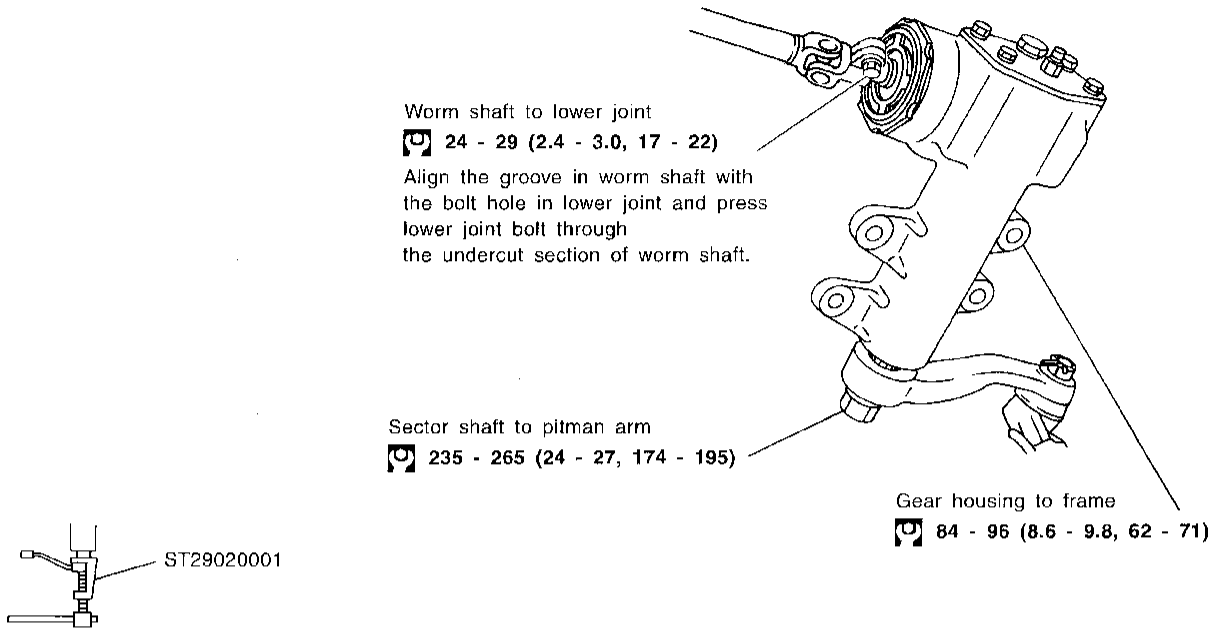

- Install pitman arm.  
 Align four grooves of gear arm serrations with four projections of sector shaft serrations, and install and tighten lock washer and nut.

[Torque symbol] : N·m (kg-m, ft-lb)

SST724C

### SEC. 480

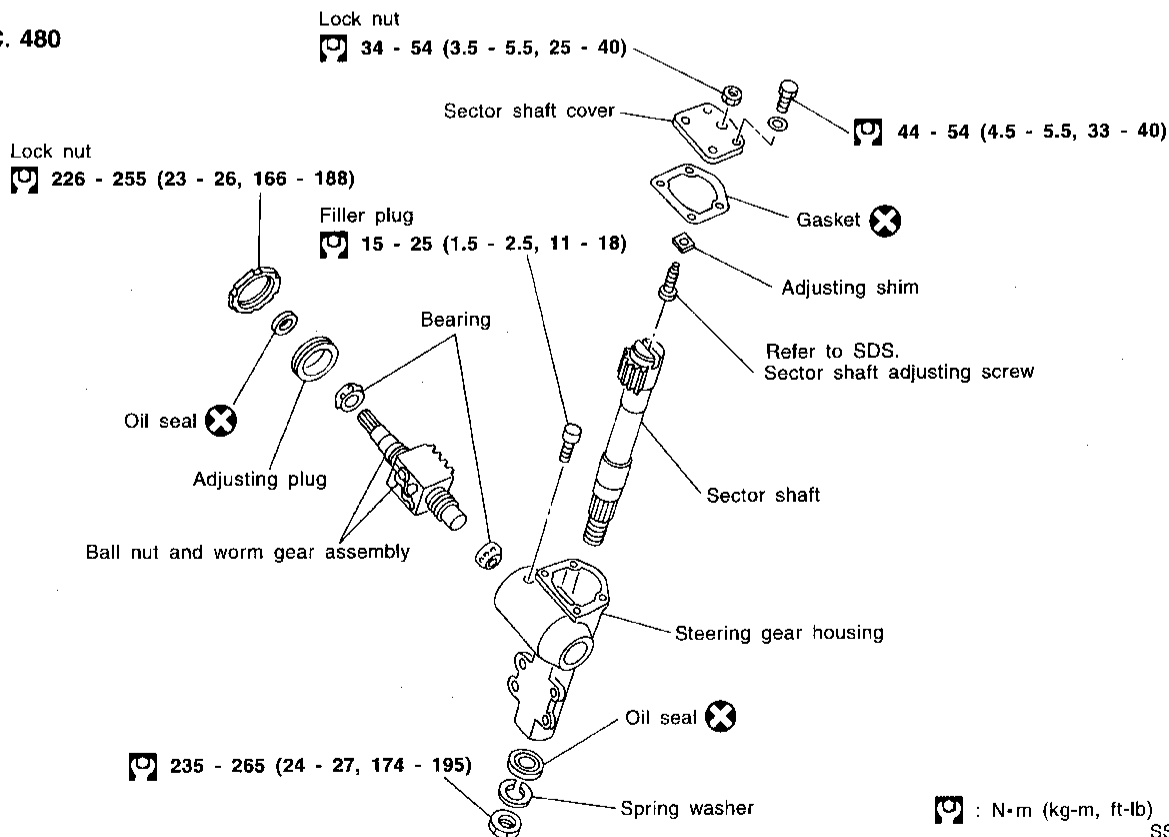

[Torque symbol] : N·m (kg-m, ft-lb)

SST744C



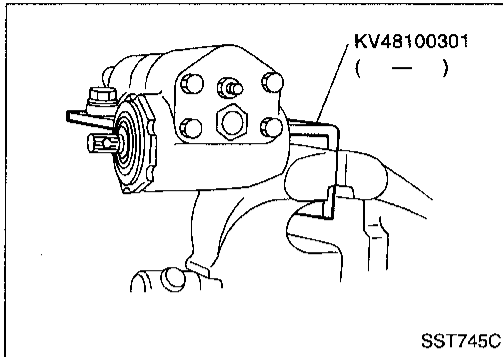

## Disassembly

1. Place steering gear in a vise using Tool.

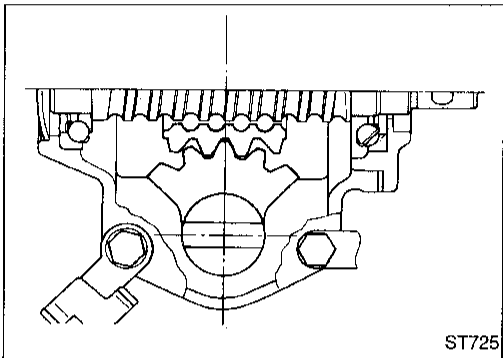

2. Set worm gear in straight-ahead position.
3. Remove sector shaft together with sector shaft cover.

### CAUTION:

- When pulling sector shaft out, be careful not to damage oil seal or associated parts.
- Do not remove sector shaft needle bearings from steering gear housing. If necessary, replace gear housing as an assembly.

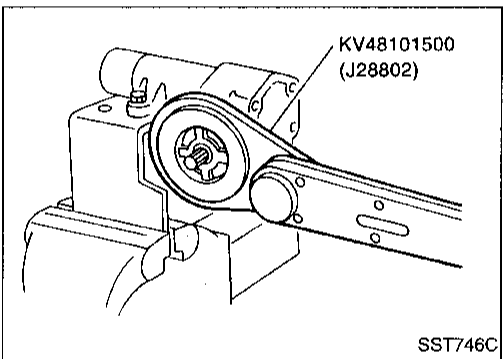

4. Loosen adjusting plug lock nut using Tool.

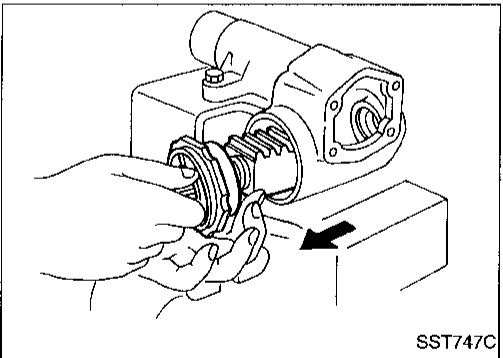

5. Remove worm gear together with worm bearing.

### CAUTION:

- Be careful not to rotate ball nut fully to either end of worm gear. Ends of ball guides will be damaged if nut is rotated until it stops at end of worm gear.
- Do not separate ball nut from worm gear assembly. If necessary, replace entire unit as an assembly.
- Do not remove sector shaft needle bearings from steering gear housing. If necessary, replace entire gear housing as an assembly.

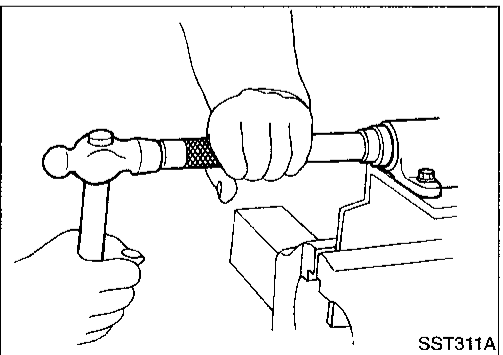

## Assembly and Adjustment

Apply multi-purpose grease to sealing area of new oil seals for sector shaft and worm gear.

### WORM GEAR BEARING PRELOAD

1. Drive oil seal into place.

Before installing oil seal, coat oil seal contacting face with gear fluid.

# MANUAL STEERING GEAR (Model: VB66K)

## Assembly and Adjustment (Cont'd)

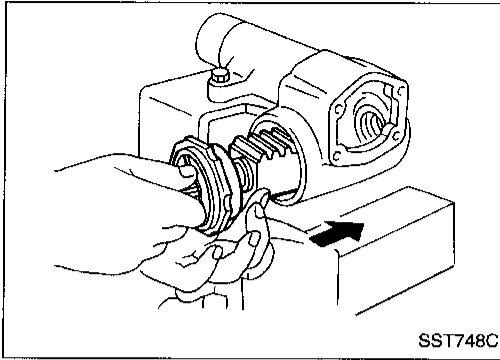

2. Place worm gear assembly together with worm gear bearing into gear housing.

GI

MA

EM

LC

EC

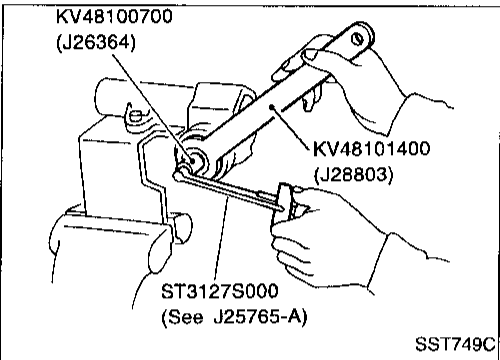

3. Adjust worm gear bearing preload using Tools.

### CAUTION:

- Always adjust worm gear bearing preload by turning adjusting plug in clockwise direction.
- Before measuring preload, rotate worm gear a few turns in both directions to seat worm gear bearing.

Worm gear bearing preload:

0.69 - 0.88 N·m (7.0 - 9.0 kg-cm, 6.1 - 7.8 in-lb)

FE

CL

MT

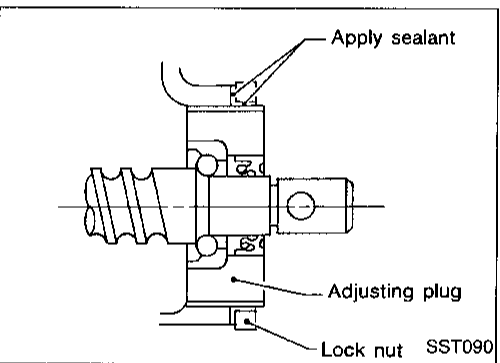

4. Apply suitable sealant to inner surface of lock nut.

AT

TF

PD

FA

RA

BR

**ST**

RS

BT

HA

EL

IDX

# MANUAL STEERING GEAR (Model: VB66K)

## Assembly and Adjustment (Cont'd)

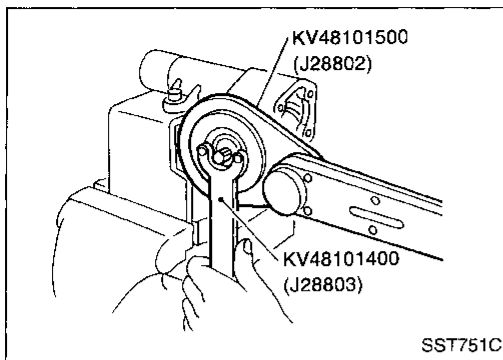

5. Tighten lock nut using Tools.

**Lock nut:**

**☞: 226 - 255 N·m (23 - 26 kg-m, 166 - 188 ft-lb)**

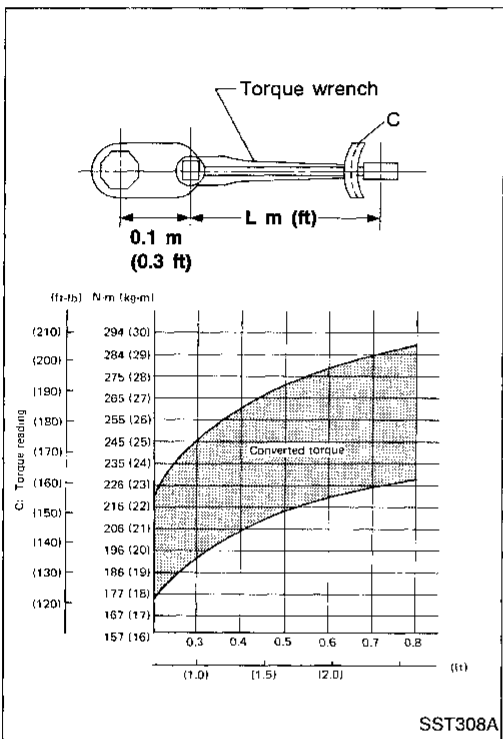

- When tightening lock nut, use the chart shown at left to determine the proper reading of torque. (Length of torque wrench vs. setting or reading of torque)
6. After tightening lock nut, check worm gear bearing preload to make sure it is within specification.

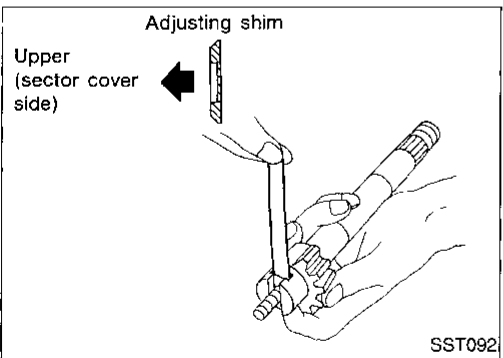

### SECTOR SHAFT END PLAY

Select and install proper adjusting shim to achieve proper end play between sector shaft and adjusting screw.

**Sector shaft end play:**

**0.1 mm (0.004 in) or less**

**Sector shaft adjusting screw shims:**

**Refer to SDS, ST-43.**

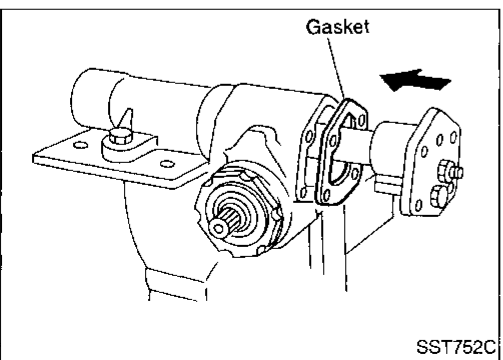

### STEERING GEAR PRELOAD AND BACKLASH

1. Set worm gear in straight-ahead position.

**Carefully insert sector shaft in gear housing, being careful not to scratch oil seal.**

2. Turn adjusting screw until sector shaft just contacts ball nut. Temporarily tighten lock nut.

3. Lubricate contacting portion of sector shaft and ball nut with gear oil or bearing grease.

# MANUAL STEERING GEAR (Model: VB66K)

## Assembly and Adjustment (Cont'd)

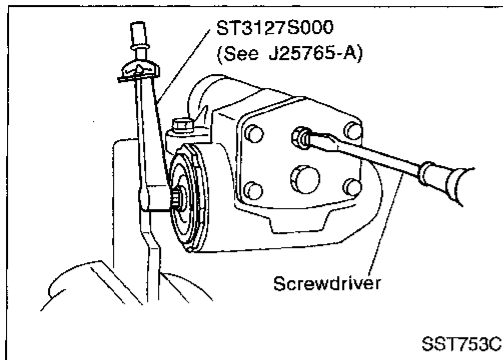

4. Adjust steering gear turning torque in a straight-ahead position using Tool, then lock with lock nut.

### CAUTION:

- Always adjust steering gear preload by turning adjusting screw in clockwise direction.
- Rotate worm gear a few turns in both directions to seat steering gear assembly.

- a. Measure turning torque at 360° position from straight-ahead position using Tools.

#### Turning torque at 360°:

0.69 - 0.88 N·m (7.0 - 9.0 kg-cm, 6.1 - 7.8 in-lb)

- b. Measure turning torque at straight-ahead position.

**Straight-ahead position is a position where stub shaft is turned 2.14 turns (two full turns and 50°) from lock position.**

#### Turning torque at straight-ahead position:

0.20 - 0.39 N·m (2.0 - 4.0 kg-cm, 1.7 - 3.5 in-lb)  
higher than turning torque at 360°

#### Maximum turning torque:

1.08 N·m (11.0 kg-cm, 9.5 in-lb)

**If turning torque is not within specifications, adjust by turning sector shaft adjusting screw.**

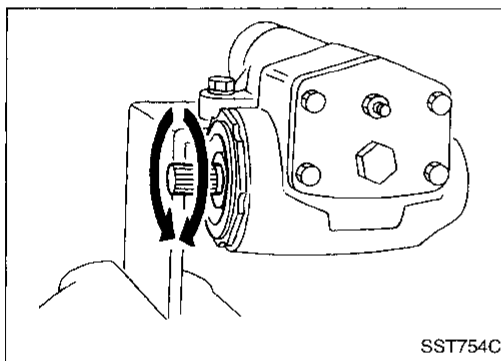

5. Turn worm gear several times by hand to properly break in worm bearing.

6. Check steering gear preload. Readjust as necessary.

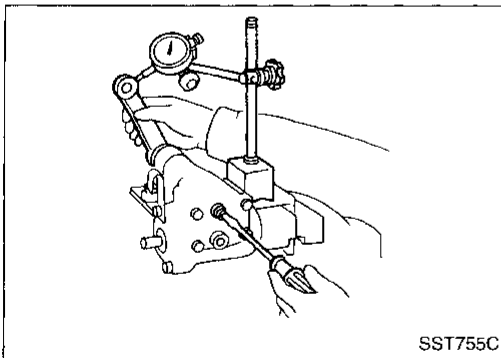

7. Measure total preload.

8. Check backlash.

Measure backlash at top end of pitman arm in straight-ahead position.

#### Backlash (in straight-ahead position):

0.1 mm (0.004 in) or less

## Inspection

**Clean all the disassembled parts in solvent, then check condition.**

## SECTOR SHAFT

1. Check gear teeth surface for pitting, burrs, cracks and any other damage, and replace as necessary.
2. Check sector shaft serration for distortion and replace as necessary. Also check gear housing for deformation.

## Inspection (Cont'd)

### STEERING WORM ASSEMBLY

1. Inspect ball nut gear teeth surface. Replace if pitting, burrs, wear or any other damage is found.
2. Ball nut must rotate smoothly on worm gear. If found to be too tight, assembly should be replaced. Check rotation of ball nut as follows:

#### CAUTION:

**Be careful not to allow ball nut to rotate fully to either end of worm gear.**

- a. Move ball nut to either end of worm gear. Gradually stand worm shaft and ball nut assembly on end until ball nut moves downward on worm gear under its own weight.
- b. If ball nut does not move freely over entire stroke, replace assembly.

**Be careful not to damage ball nut guide tube while check is being made.**

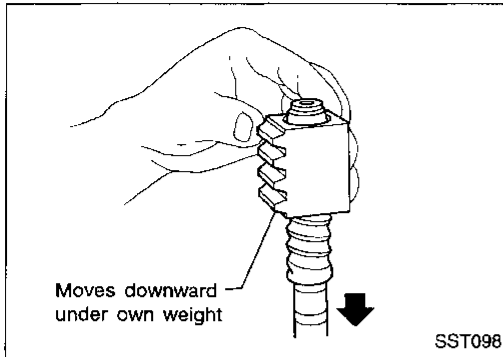

### BEARING

1. Inspect worm gear bearing for wear, pitting and any other damage. Replace as necessary.

**When replacing worm gear bearing, replace bearing and outer race as a set.**

2. If sector shaft needle bearings are worn or damaged, replace gear housing as an assembly.

### OIL SEALS

- Discard any oil seal which has been removed.
- Replace oil seal if sealing surface is deformed or cracked.
- Discard oil seal if spring is fatigued or dislocated.

# POWER STEERING SYSTEM (Model: PB48S)

## Description

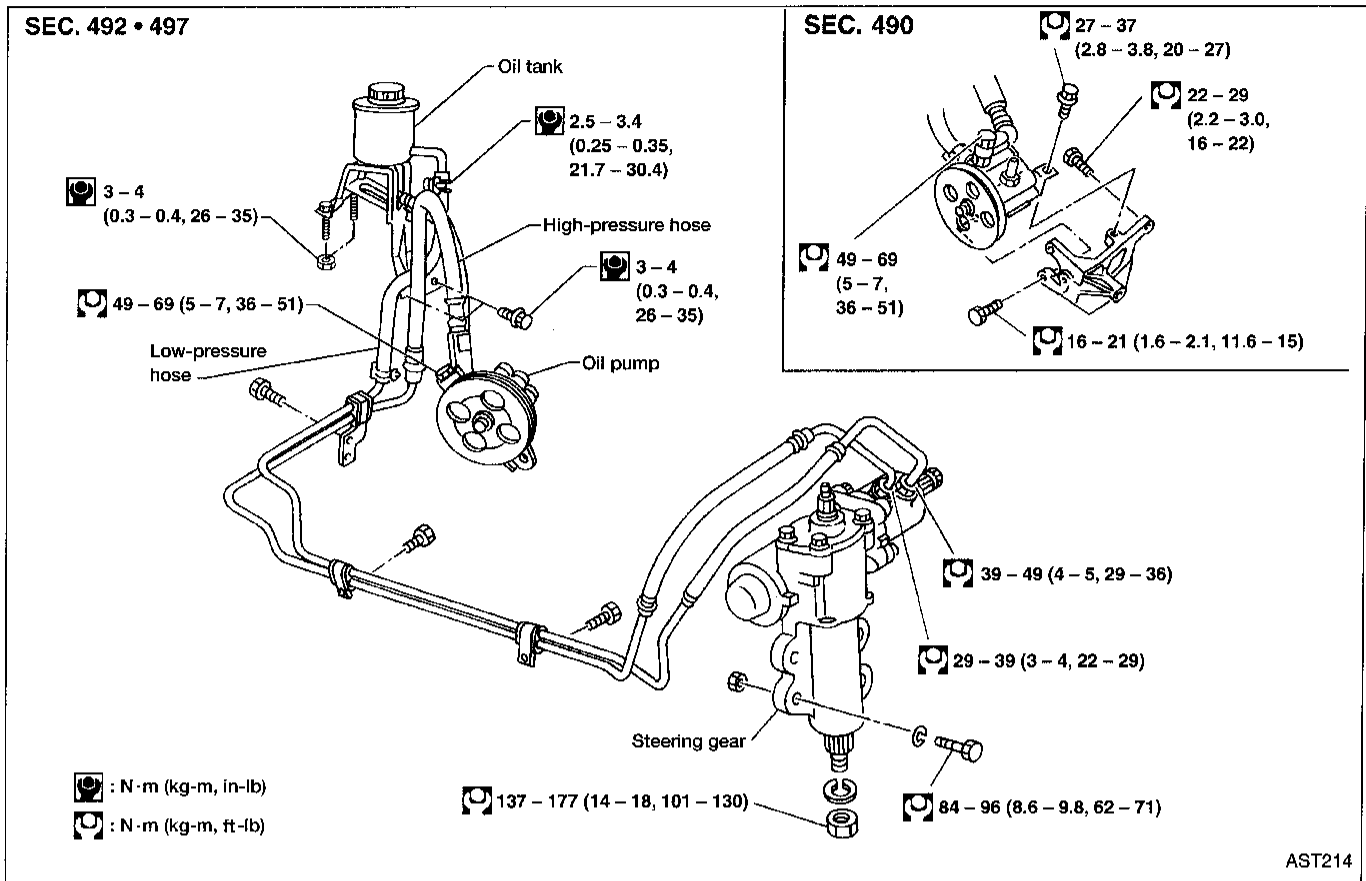

### CAUTION:

- Parts which can be disassembled are strictly limited. Never disassemble parts other than those specified.
- Disassemble in as clean a place as possible.
- Clean your hands before disassembly.
- Do not use rags; use nylon cloths or paper towels.
- Follow the procedures and cautions indicated in the Service Manual.

GI  
MA  
EM  
LC  
EC  
FE  
CL  
MT  
AT  
TF  
PD  
FA  
RA  
BR  
ST  
RS  
BT  
HA  
EL  
IDX

# POWER STEERING GEAR (Model: PB48S)

## Removal and Installation

Before removal, clean gear housing and oil pump exteriors using a steam cleaner. Then dry with compressed air.

### STEERING GEAR

SEC. 492

- Plug openings of gear housing, and securely locate hose connectors at a position higher than oil pump and cover with rag.
- Be extremely careful to prevent entry of foreign matter into hoses through connectors.
- When installing gear arm, align four grooves of gear arm serrations with four projections of sector shaft serrations, and install and tighten lock washer and nut.

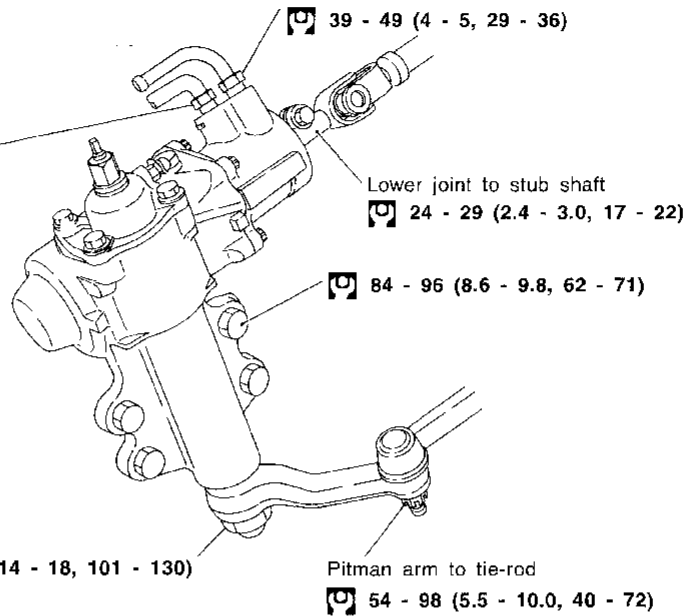

: N·m (kg-m, ft-lb)

AST207

## Power Steering Gear Component

SEC. 492

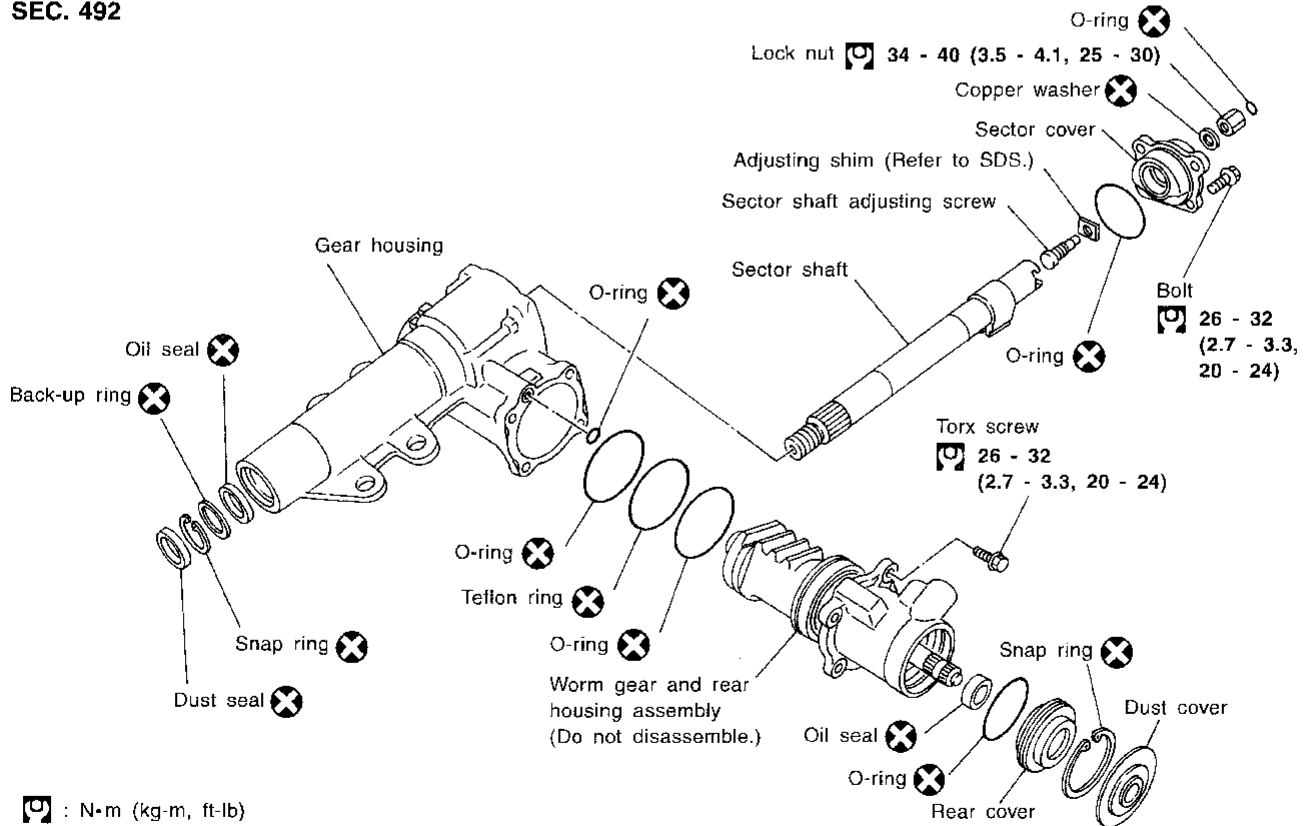

: N·m (kg-m, ft-lb)

SST725C

## Pre-disassembly Inspection and Adjustment

Before disassembling power steering gear component parts, make sure there is no oil leakage around sealing portion and check steering turning torque as follows:

Check sealing portion.

- Adjusting screw nut O-ring
- Sector shaft cover O-ring
- Sector shaft oil seal
- Rear cover oil seal and O-ring
- Rear housing O-ring
- Gear housing O-ring

Discard any oil seal and O-ring which have been removed. Replace oil seal and O-ring if sealing surface is deformed or cracked.

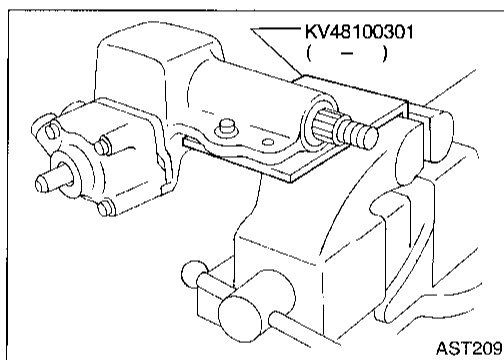

## TURNING TORQUE MEASUREMENT

1. Measure turning torque at 360° position.
  - a. Install steering gear on Tool.

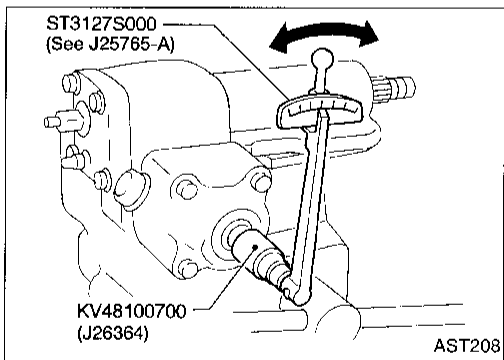

- b. Turn stub shaft all the way to right and left several times.
  - c. Measure turning torque at 360° position from straight-ahead position with Tools.

**Turning torque at 360°:**

**0.7 - 1.2 N·m (7 - 12 kg-cm, 6.1 - 10.4 in-lb)**

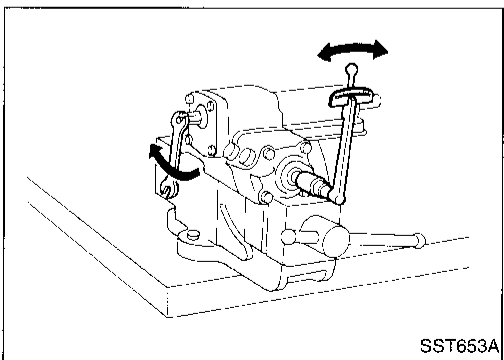

- d. Measure turning torque at straight-ahead position. **Straight-ahead position is a position where stub shaft is turned 2.14 turns (two full turns and 50°) from lock position.**

**Turning torque at straight-ahead position:**

**0.1 - 0.4 N·m (1 - 4 kg-cm, 0.9 - 3.5 in-lb)**

**higher than turning torque at 360°**

**Maximum turning torque:**

**1.1 - 1.6 N·m (11 - 16 kg-cm, 9.5 - 13.9 in-lb)**

If turning torque is not within specifications, adjust by turning sector shaft adjusting screw.



# POWER STEERING GEAR (Model: PB48S)

## Pre-disassembly Inspection and Adjustment (Cont'd)

2. Tighten adjusting screw lock nut with tools.

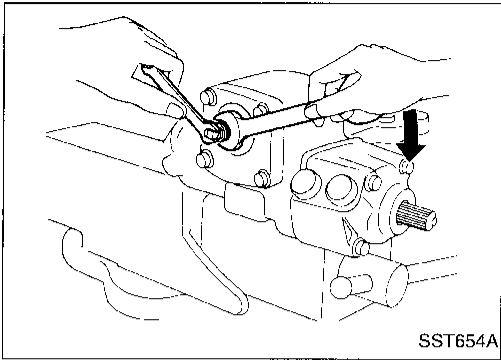

## Disassembly

Before disassembly, measure turning torque.

If not within specifications, replace steering gear assembly.

### CAUTION:

Oil sealing parts, copper washer and snap ring must not be used again after removal.

## ADJUSTING SCREW LOCK NUT O-RING

Remove adjusting screw lock nut, and replace O-ring.

## SECTOR SHAFT OIL SEAL

1. Set stub shaft in straight-ahead position.

**Straight-ahead position is a position where stub shaft is turned 2.14 turns (two full turns and 50°) from lock position.**

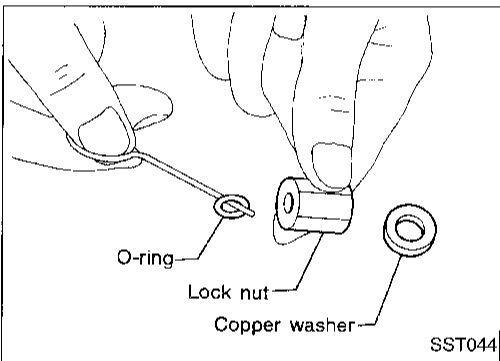

2. Disconnect sector shaft cover bolt.

**Do not turn lock nut unless necessary; otherwise it will damage O-ring, resulting in an oil leak.**

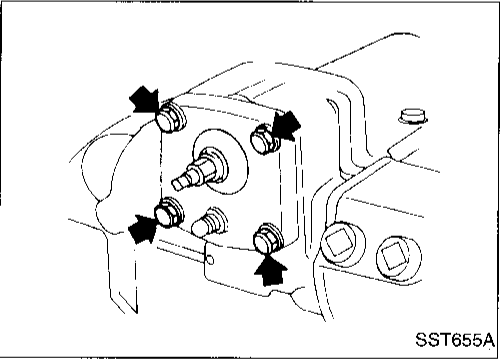

3. Draw out sector shaft.

**Knock out end of sector shaft approximately 20 mm (0.79 in).**

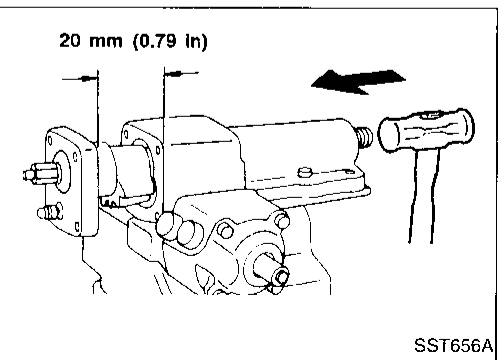

# POWER STEERING GEAR (Model: PB48S)

## Disassembly (Cont'd)

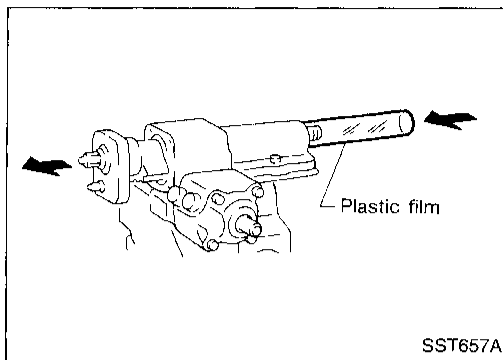

4. Connect a roll of plastic film to sector shaft.

**Plastic film:**

**Thickness 0.1 mm (0.004 in)**

**Length x width**

**200 x 200 mm (7.87 x 7.87 in)**

5. Pull out sector shaft by hand.

**Attach plastic film to needle bearings located at two places inside gear housing while simultaneously pulling out sector shaft so that bearings will not drop into housing.**

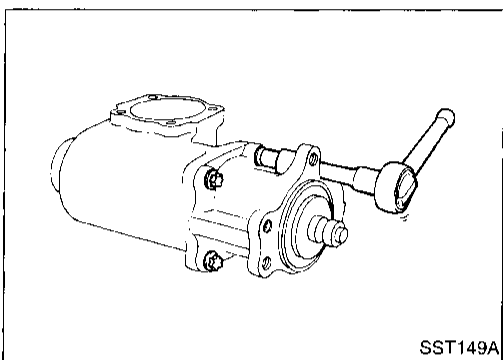

## REAR HOUSING O-RING

1. Remove torx screw.

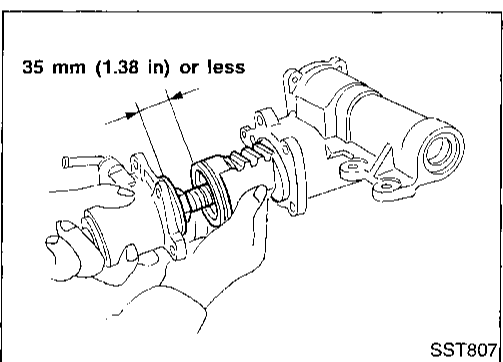

2. Remove rear housing together with worm gear assembly.

### CAUTION:

- When worm gear assembly is removed, piston may turn and come off under its own weight. Hold piston to prevent it from turning.
- If piston-to-rear housing clearance exceeds 35 mm (1.38 in) recirculating ball will be out of groove of worm gear; do not reinstall piston but replace the entire assembly.
- Be careful not to damage teflon ring at piston end when removing.

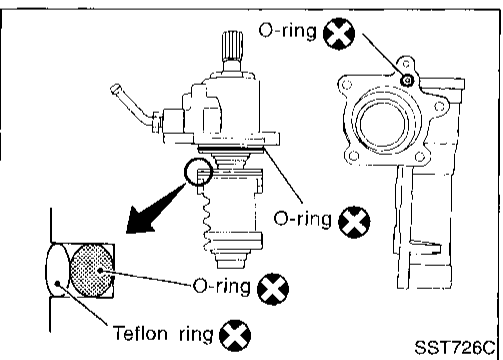

3. Remove O-rings and teflon ring.

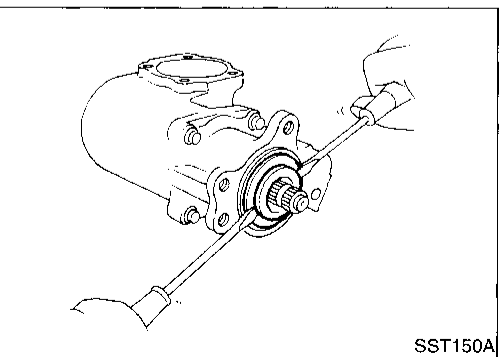

## REAR COVER O-RING AND OIL SEAL

1. Remove snap ring, then rear cover.
2. Remove O-ring and oil seal.

GI

MA

EM

LC

EC

FE

CL

MT

AT

TF

PD

FA

RA

BR

ST

RS

BY

HA

EL

IDX

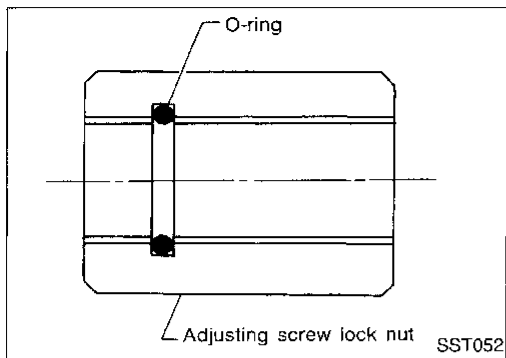

## Assembly

### ADJUSTING SCREW LOCK NUT O-RING

Insert new O-ring into adjusting screw lock nut.

- Before inserting, apply a thin coat of petroleum jelly to O-ring.
- Insert O-ring to make sure it fits into groove.

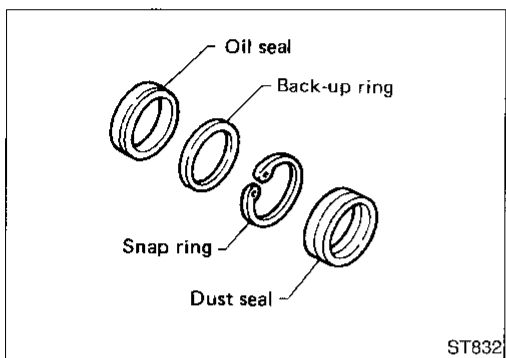

### SECTOR SHAFT OIL SEAL

- When installing, be sure to use new oil seal, dust seal, back-up ring and snap ring.
- Before installing, apply a thin coat of petroleum jelly to new oil seal and dust seal.

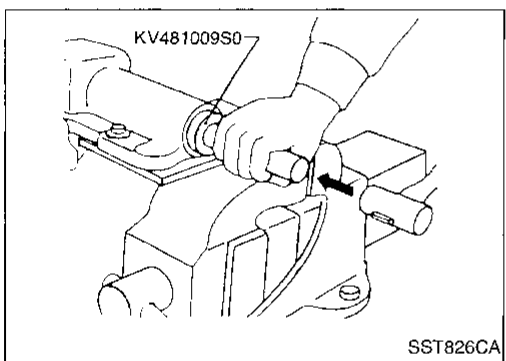

1. Press new oil seal and then install back-up ring with Tool.

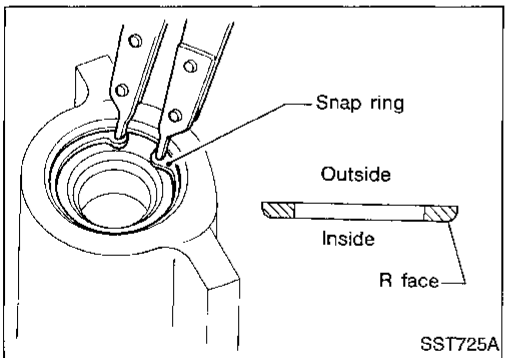

2. Install a new snap ring into gear housing.

#### CAUTION:

- Turn snap ring to make sure it fits into groove.
- Always install snap ring with R face facing inward.

3. Press a new dust seal.

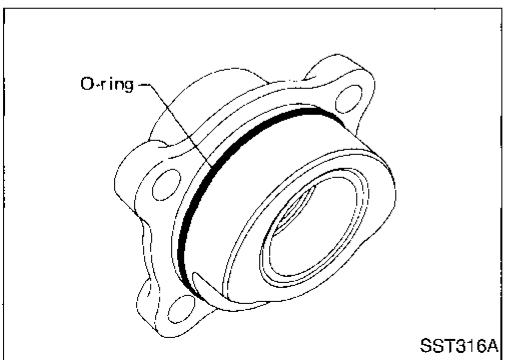

4. Fit new O-ring into sector shaft cover.

- Before installing, apply a thin coat of petroleum jelly to O-ring.
- Make sure that O-ring is installed properly and is not damaged by sector shaft.

# POWER STEERING GEAR (Model: PB48S)

## Assembly (Cont'd)

### SECTOR SHAFT END PLAY

Select suitable adjusting shim and adjust end play between sector shaft and adjusting screw.

**Sector shaft end play:**  
0.01 - 0.03 mm (0.0004 - 0.0012 in)

**Sector shaft adjusting screw shims:**  
Refer to SDS, ST-43.

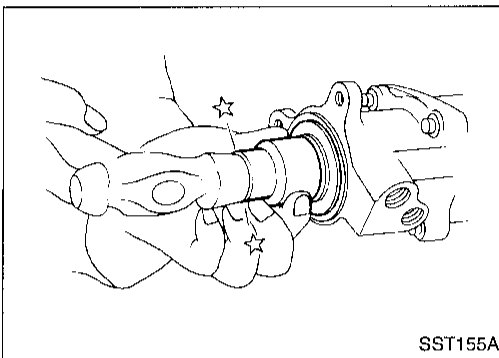
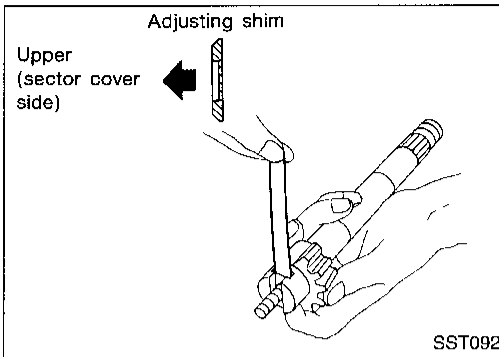

### REAR COVER O-RING AND OIL SEAL

1. Install new O-ring and oil seal.
2. Install rear cover, then install new snap ring.

#### CAUTION:

- Turn snap ring to make sure it fits into grooves.
- Always install snap ring with its rounded edge facing rear cover.

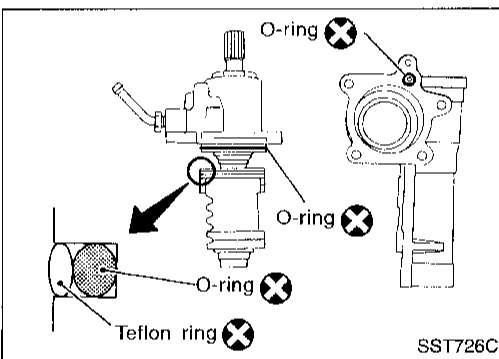

### REAR HOUSING O-RING

1. Install new O-rings and teflon ring.
  - a. Before installing, apply a thin coat of petroleum jelly to rings.
  - b. Make sure rings are installed correctly and are not damaged by worm gear.

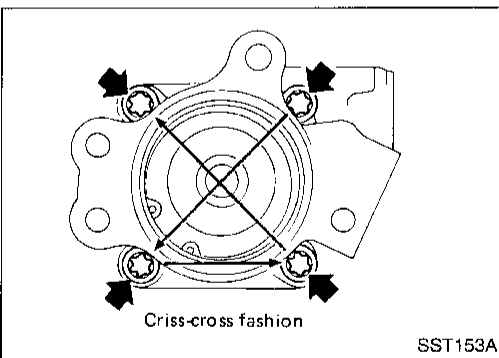

2. Gradually insert worm gear and rear housing assembly into gear housing, being careful not to damage oil seal and O-rings.
3. Install torx screws.

GI

MA

EM

LC

EC

FE

CL

MT

AT

TF

PD

FA

RA

BR

ST

RS

BT

HA

EL

IDX

## POWER STEERING GEAR (Model: PB48S)

### Assembly (Cont'd)

#### SECTOR SHAFT

1. Set piston rack at straight-ahead position.

Turn piston rack about 10° to 15° toward yourself with your finger. This permits smooth insertion of sector gear.

2. Wrap vinyl tape around serration area of sector shaft.

Vinyl tape prevents oil seal lip from being damaged during insertion.

3. Gradually insert sector shaft into gear housing, being careful not to damage oil seal.

When inserting sector shaft into gear housing, remove plastic film. Be careful not to drop bearings into gear housing.

4. Tighten sector shaft cover bolts.

5. Check turning torque and steering gear preload.

Refer to "TURNING TORQUE MEASUREMENT", "Pre-disassembly Inspection and Adjustment", ST-23.

- If turning torque is considerably different from the value before disassembly, replace the entire assembly.

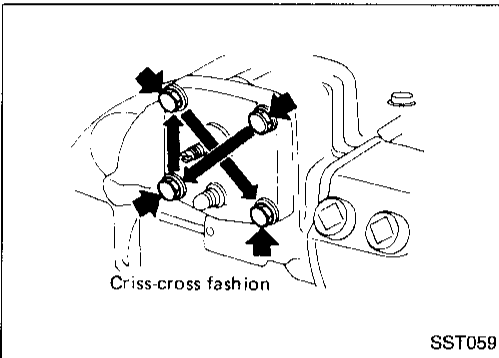
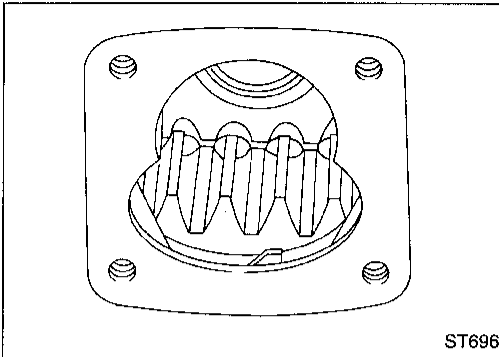

# POWER STEERING SYSTEM (Model: PB59K)

## Description

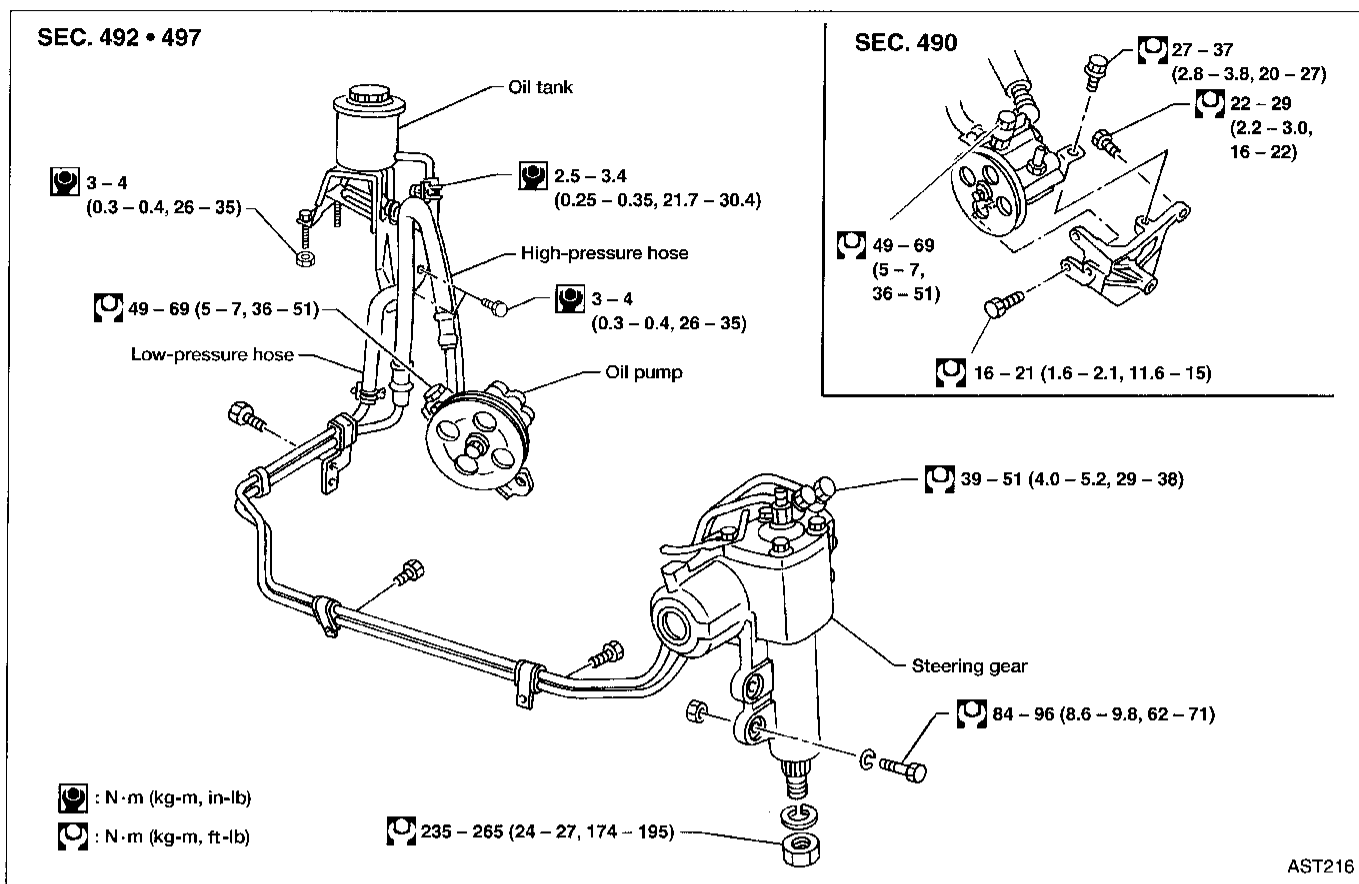

### CAUTION:

- Parts which can be disassembled are strictly limited. Never disassemble parts other than those specified.
- Disassemble in as clean a place as possible.
- Clean your hands before disassembly.
- Do not use rags; use nylon cloths or paper towels.
- Follow the procedures and cautions indicated in the Service Manual.

GI  
MA  
EM  
LC  
EC  
FE  
CL  
MT  
AT  
TF  
PD  
FA  
RA  
BR  
ST  
RS  
BT  
HA  
EL  
IDX

# POWER STEERING GEAR (Model: PB59K)

## Removal and Installation

Before removal, clean gear housing and oil pump exteriors using a steam cleaner. Then dry with compressed air.

### STEERING GEAR

SEC. 492

- Plug openings of gear housing, and securely locate hose connectors at a position higher than oil pump and cover with rag.
- Be extremely careful to prevent entry of foreign matter into hoses through connectors.
- When installing gear arm, align four grooves of gear arm serrations with four projections of sector shaft serrations, and install and tighten lock washer and nut.

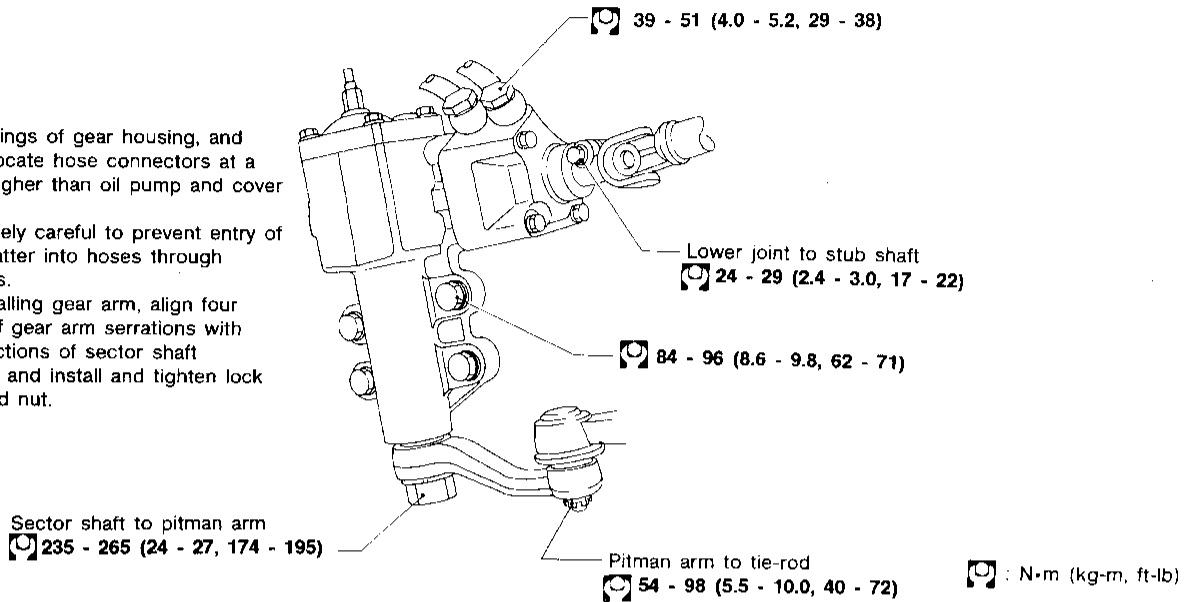

SST123CB

## Power Steering Gear Component

SEC. 492

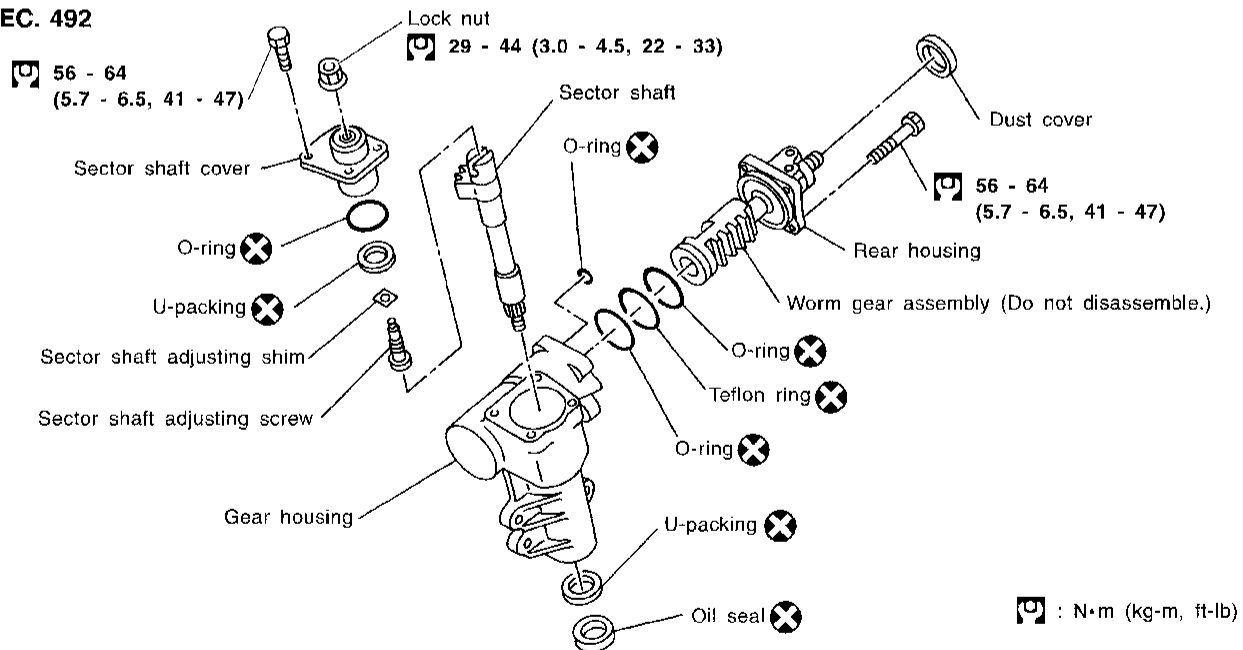

SST733C

## Pre-disassembly Inspection and Adjustment

Before disassembling power steering gear component parts, make sure there is no oil leakage around sealing portion and check steering turning torque as follows:

Check sealing portion.

- Sector shaft cover O-ring
- Sector shaft U-packing
- Sector shaft oil seal
- Rear housing O-ring
- Gear housing O-ring

Discard any oil seal and O-ring which have been removed.

Replace oil seal and O-ring if sealing surface is deformed or cracked.

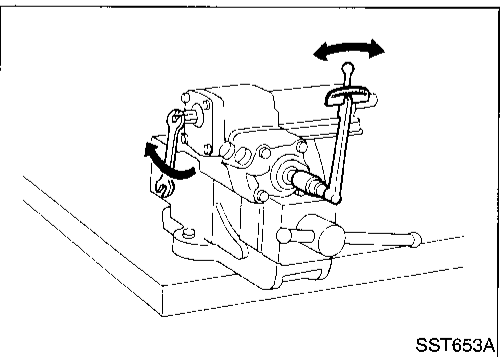
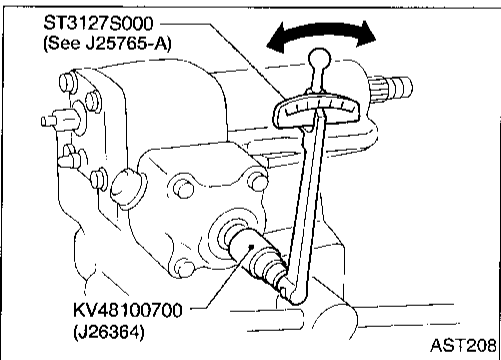
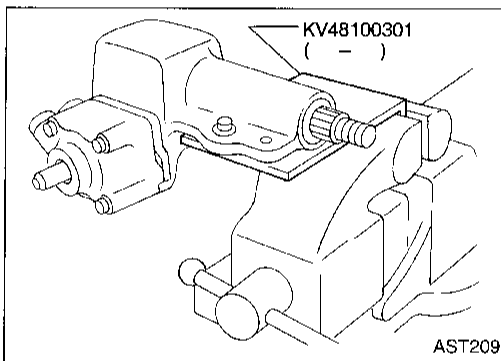

## TURNING TORQUE MEASUREMENT

1. Measure turning torque at 360° position.
  - a. Install steering gear on Tool.

- b. Turn stub shaft all the way to right and left several times.
  - c. Measure turning torque at 360° position from straight-ahead position with Tools.

**Turning torque at 360°:**

**0.15 - 0.78 N·m (1.5 - 8.0 kg-cm, 1.3 - 6.9 in-lb)**

- d. Measure turning torque at straight-ahead position.

**Straight-ahead position is a position where stub shaft is turned 2.14 turns (two full turns and 50°) from lock position.**

**Turning torque at straight-ahead position:**

**.25 - 1.32 N·m (2.5 - 13.5 kg-cm, 2.3 - 11.6 in-lb)**

**higher than turning torque at 360°**

**Maximum turning torque:**

**1.03 - 1.47 N·m (10.5 - 15 kg-cm, 9.2 - 13.0 in-lb)**

If turning torque is not within specifications, adjust by turning sector shaft adjusting screw.

GI  
MA  
EM  
LC  
EC  
FE  
CL  
MT  
AT  
TF  
PD  
FA  
RA  
BR  
ST  
RS  
BT  
HA  
EL  
IDX



# POWER STEERING GEAR (Model: PB59K)

## Pre-disassembly Inspection and Adjustment (Cont'd)

2. Tighten adjusting screw lock nut with tools.

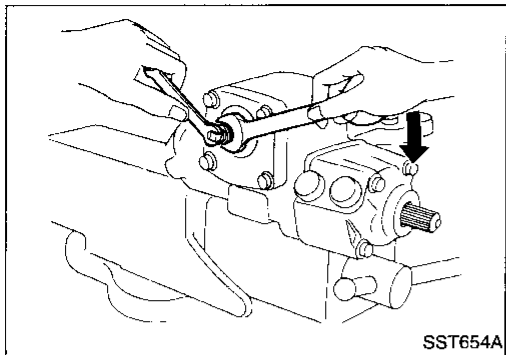

## Disassembly

Before disassembly, measure turning torque.

If not within specifications, replace steering gear assembly.

### CAUTION:

Oil sealing parts and snap ring must not be used again after removal.

1. Place steering gear in a vise with Tool.
2. Set worm gear in straight-ahead position.
3. Loosen (do not remove) sector shaft cover bolt.
4. Knock out end of sector shaft with a plastic hammer.
5. Remove sector shaft by hand.

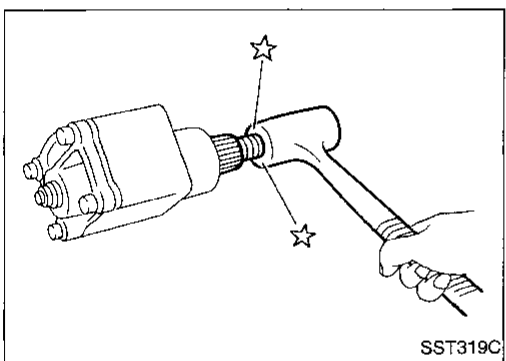
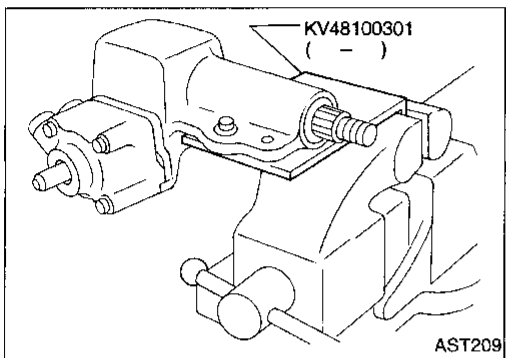

6. Remove oil seal.
7. Remove U-packing.

### CAUTION:

When removing oil seal and U-packing, be careful not to scratch gear housing.

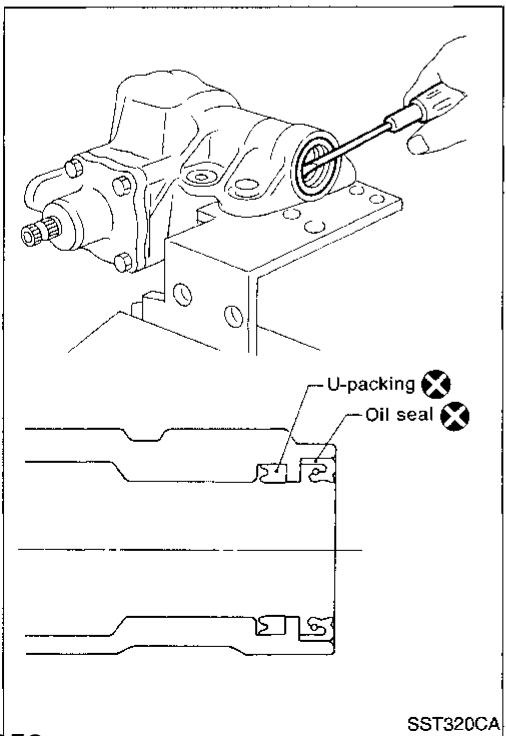

# POWER STEERING GEAR (Model: PB59K)

## Disassembly (Cont'd)

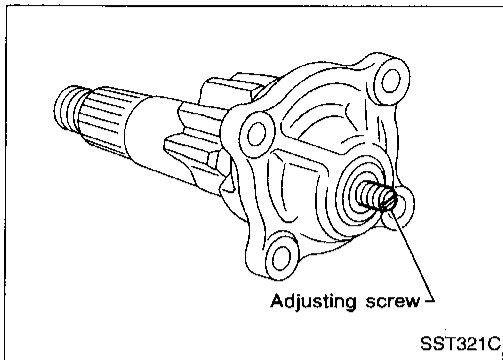

8. Remove lock nut, then loosen adjusting screw using a screwdriver. Separate sector cover and sector shaft.

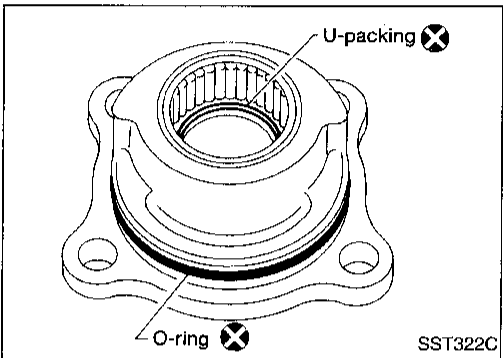

9. Remove O-ring.  
10. Remove U-packing.

### CAUTION:

- When removing U-packing, be careful not to scratch sector cover, needle bearing, etc.
- Needle bearing cannot be disassembled. If it is damaged, remove sector cover assembly.

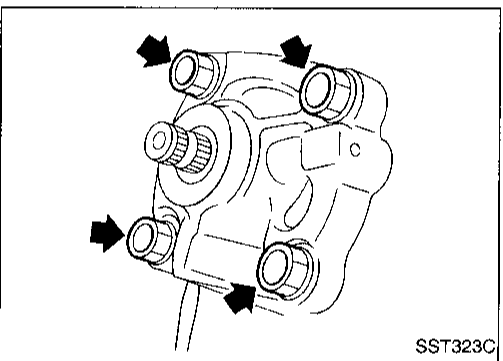

11. Remove dust seal.  
12. Remove rear housing bolts.  
13. Remove rear housing together with worm gear assembly.

### CAUTION:

**Worm gear assembly cannot be disassembled. When it is removed, be careful not to disengage worm gear from shaft or allow it to drop.**

14. Remove teflon ring and O-ring of worm gear assembly.

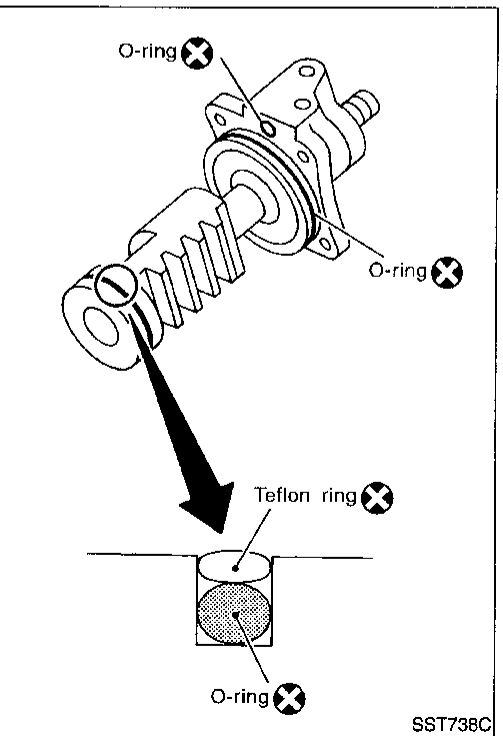

## Assembly

1. Install new O-ring on worm gear assembly.
  - Apply a thin coat of ATF to new O-ring.
2. Install new teflon ring on worm gear assembly.
  - Make sure that teflon ring is seated in correct position.
3. Install new O-rings into rear housing.

GI  
MA  
EM  
LC  
EC  
FE  
CL  
MT  
AT  
TF  
PD  
FA  
RA  
BR  
ST  
RS  
BT  
HA  
EL  
IDX

## POWER STEERING GEAR (Model: PB59K)

### Assembly (Cont'd)

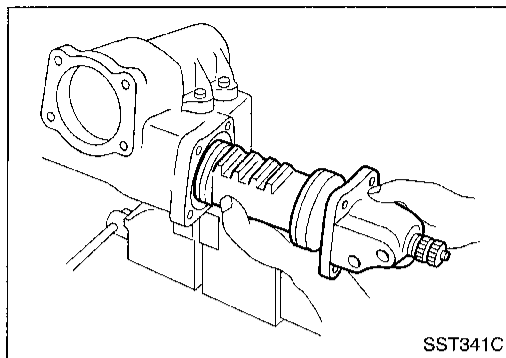

4. Install worm gear assembly with rear housing into the gear housing.

#### CAUTION:

- Apply a thin coat of ATF inside gear housing and piston before insertion.
- Be careful not to damage teflon ring at piston end when inserting worm gear assembly into gear housing.

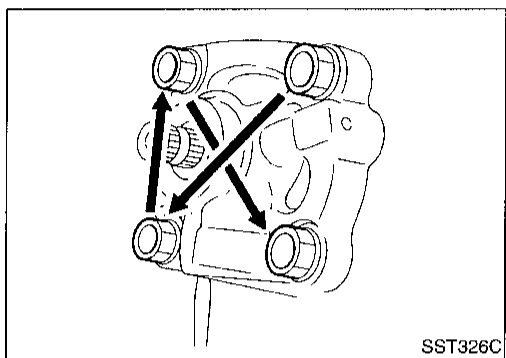

5. Gradually tighten rear housing bolts in a criss-cross fashion.

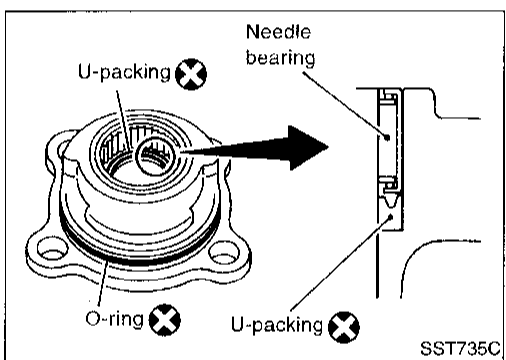

6. Install new O-ring into sector shaft cover.
  - Before installing, apply a thin coat of ATF to O-ring.
7. Install new U-packing into sector shaft cover.
  - Before installing, apply a thin coat of ATF to U-packing.
  - Direct grooved side of U-packing to needle bearing.

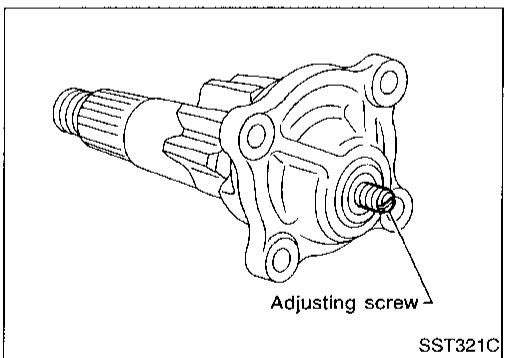

8. Install sector shaft into sector shaft cover.  
Set adjusting screw to its outermost position.
  - Before installing sector shaft, apply multi-purpose grease to adjusting screw and adjusting screw shim.

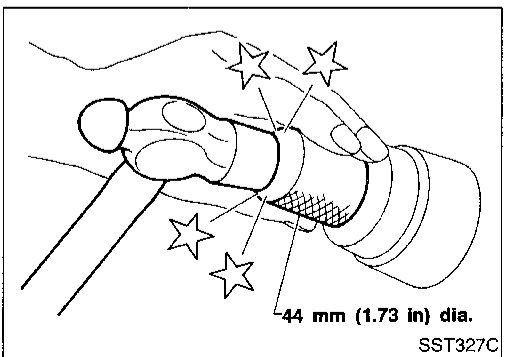

9. Install new oil seal into gear housing with suitable tool.
  - Before installing oil seal, apply multi-purpose grease to oil seal lips.

# POWER STEERING GEAR (Model: PB59K)

## Assembly (Cont'd)

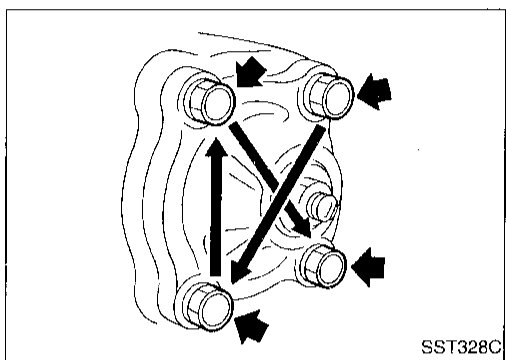
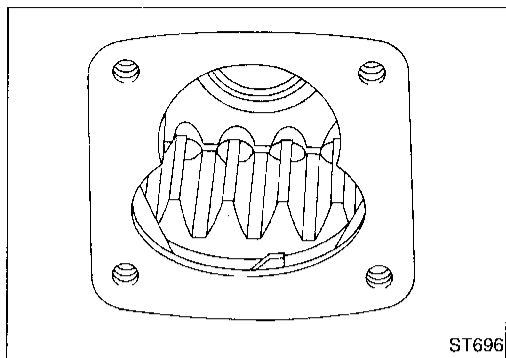

10. Set piston rack at straight-ahead position.

Turn piston rack about 10° to 15° toward yourself with your finger.

This enables smooth insertion of sector gear.

11. Gradually insert sector shaft into gear housing.

12. Tighten sector shaft cover bolts.

13. Set worm gear turning torque by turning sector shaft adjusting screw and locking with lock nut.

Refer to "TURNING TORQUE MEASUREMENT", "Pre-disassembly and Adjustment", ST-31.

- If set and adjusting turning torque is considerably different from the value before disassembly, replace the entire assembly.

14. Check sector shaft end play in neutral position.

**End play:**

**Less than 0.1 mm (0.004 in)**

If not within specification, adjust it with adjusting screw.

15. Check worm gear preload. If not within specification, readjust it.

CF

MA

EM

LC

EC

FE

CL

MT

AT

TF

PD

FA

RA

BR

**ST**

RS

BT

HA

EL

IDX

# POWER STEERING OIL PUMP

## Disassembly and Assembly

SEC. 490

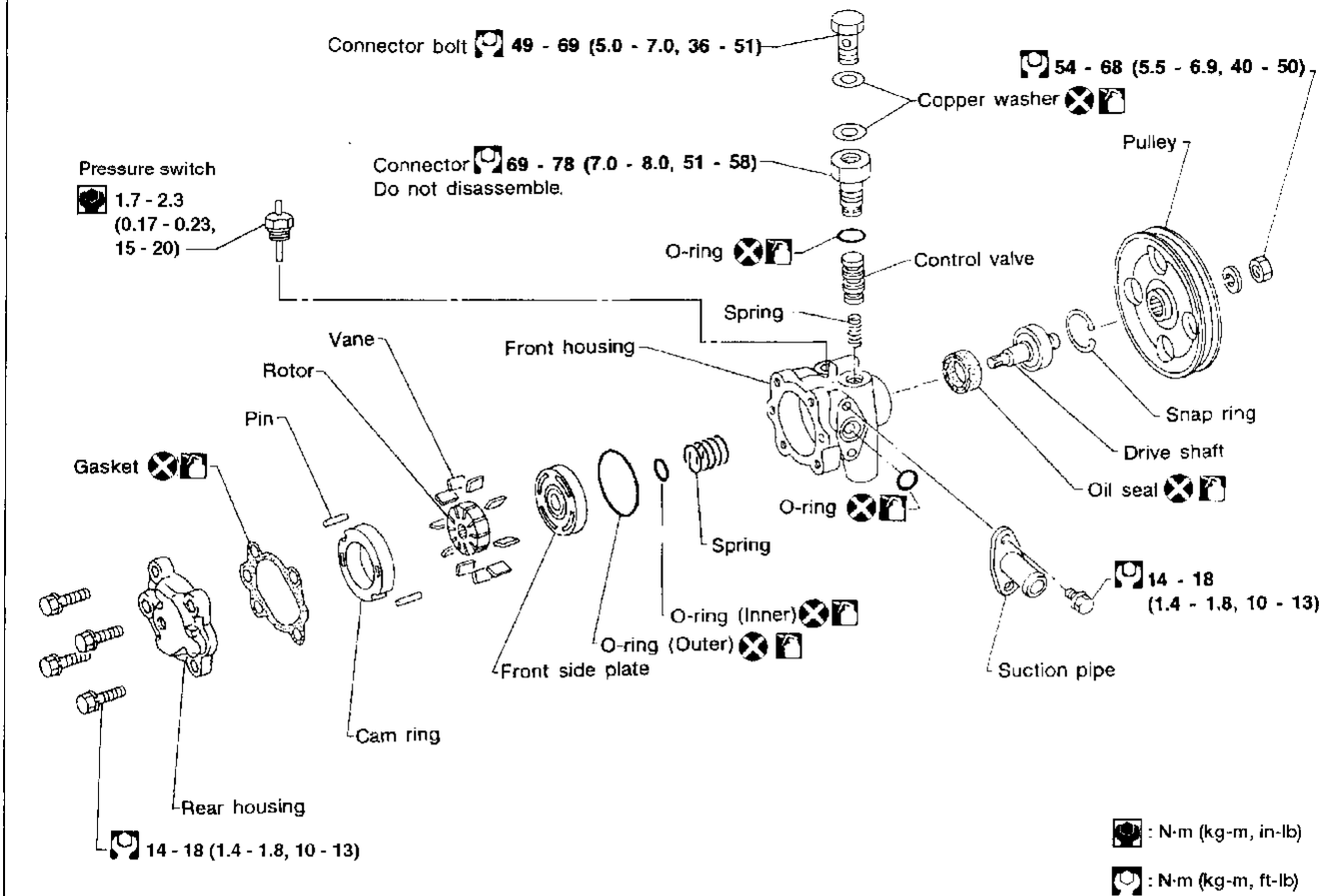

AST210

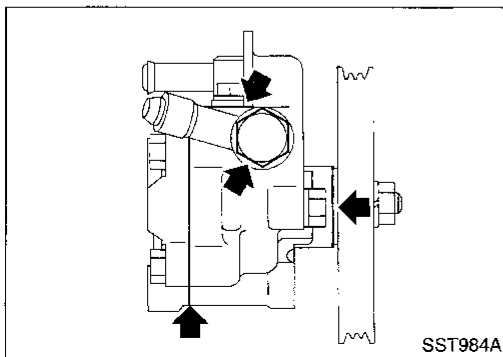

### Pre-disassembly Inspection

Disassemble the power steering oil pump only if the following items are found.

- Oil leak from any point shown in the figure.
- Deformed or damaged pulley.
- Poor performance.

## Inspection

### PULLEY AND PULLEY SHAFT

- If pulley is cracked or deformed, replace it.
- If fluid leak is found around the pulley shaft, replace the oil seal.

## Disassembly

### CAUTION:

- Parts which can be disassembled are strictly limited. Never disassemble parts other than those specified.
- Disassemble in as clean a place as possible.
- Clean your hands before disassembly.
- Do not use rags; use nylon cloths or paper towels.
- When disassembling and reassembling, do not let foreign matter enter or contact the parts.

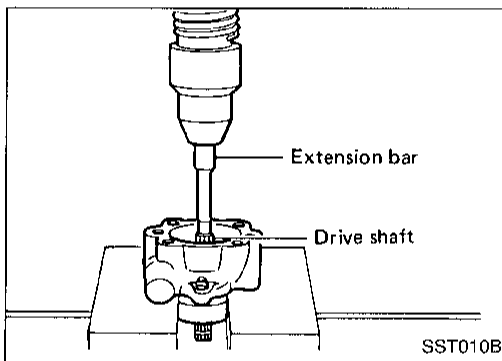

- Remove snap ring, then draw drive shaft out.
- Be careful not to drop drive shaft.

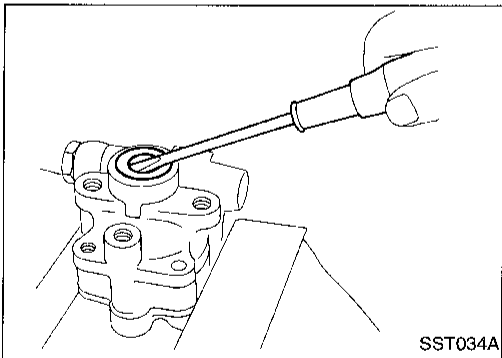

- Remove oil seal.
- Be careful not to damage front housing.

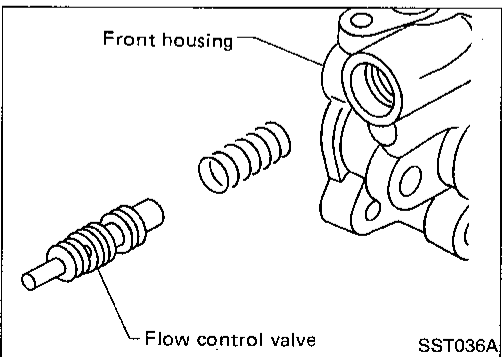

- Remove connector.
- Be careful not to drop control valve.

GI  
MA  
EM  
LC  
EC  
FE  
CL  
MT  
AT  
TF  
PD  
FA  
RA  
BR  
ST  
RS  
BT  
HA  
EL  
IDX

# POWER STEERING OIL PUMP

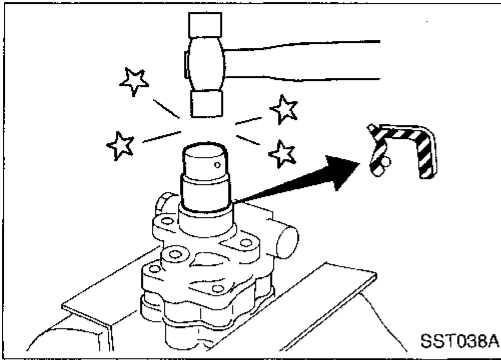

## Assembly

Assemble oil pump, noting the following instructions.

- Make sure O-rings and oil seal are properly installed.
- Always install new O-rings and oil seal.
- Be careful of oil seal direction.
- Cam ring, rotor and vanes must be replaced as a set if necessary.
- When assembling, coat each part with ATF.

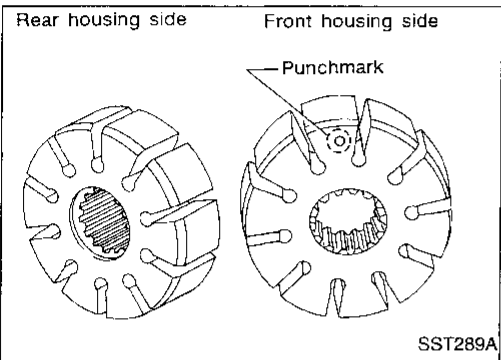

- Pay attention to the direction of rotor.

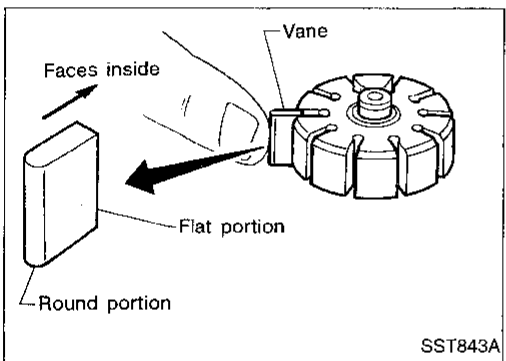

- When assembling vanes to rotor, rounded surfaces of vanes must face cam ring side.

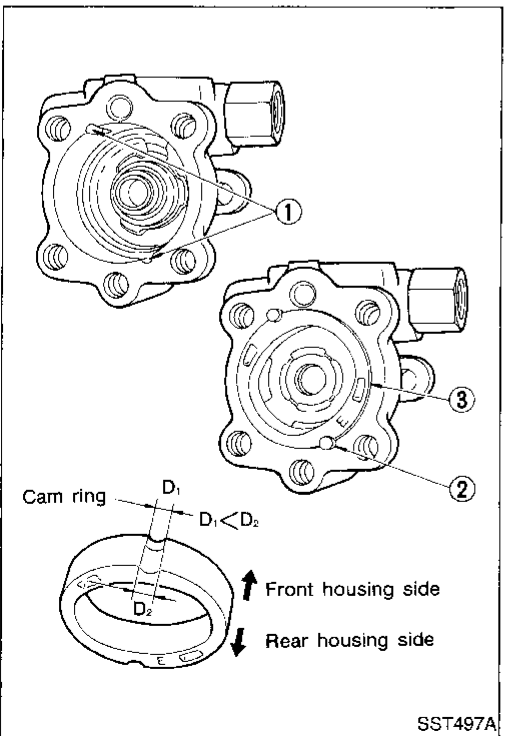

- Insert pin ② into pin groove ① of front housing and front side plate. Then install cam ring ③ as shown at left.

**Cam ring:**

$D_1$  is less than  $D_2$

# STEERING LINKAGE

## Removal and Installation

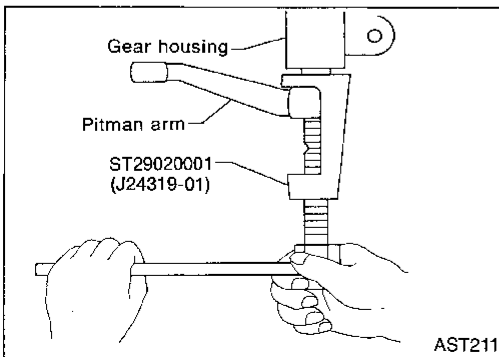
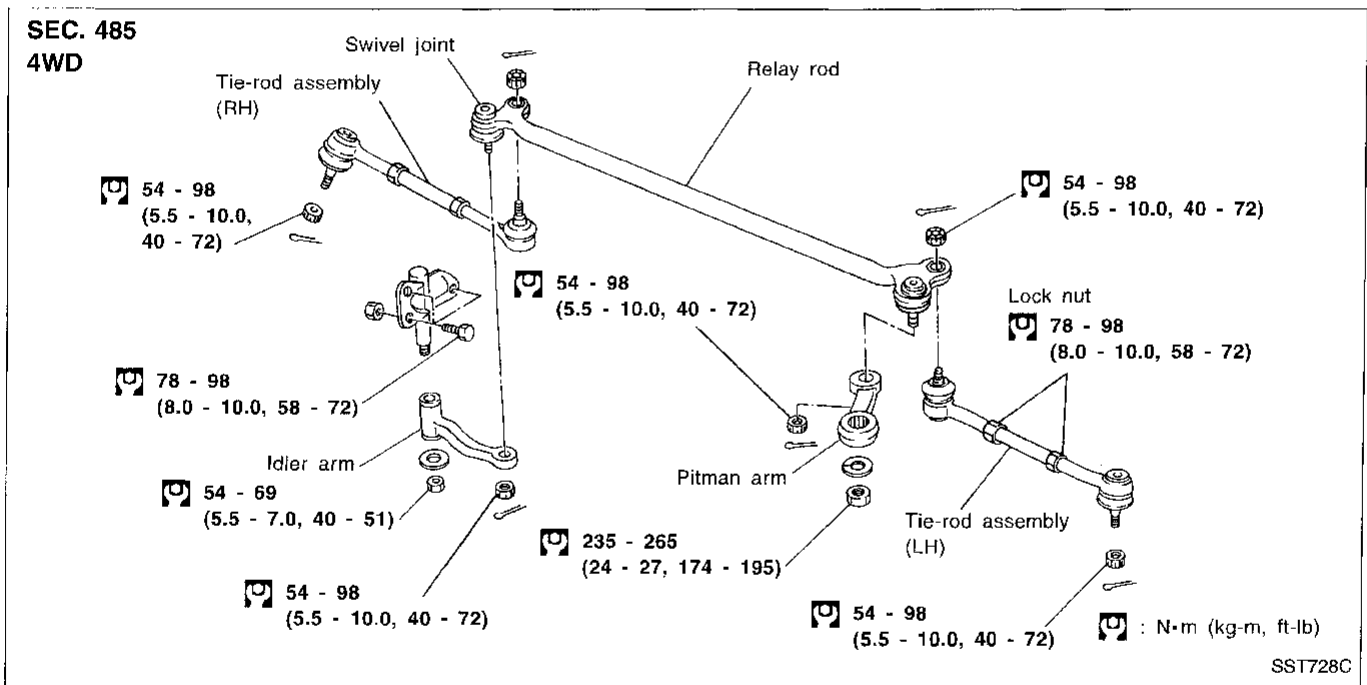
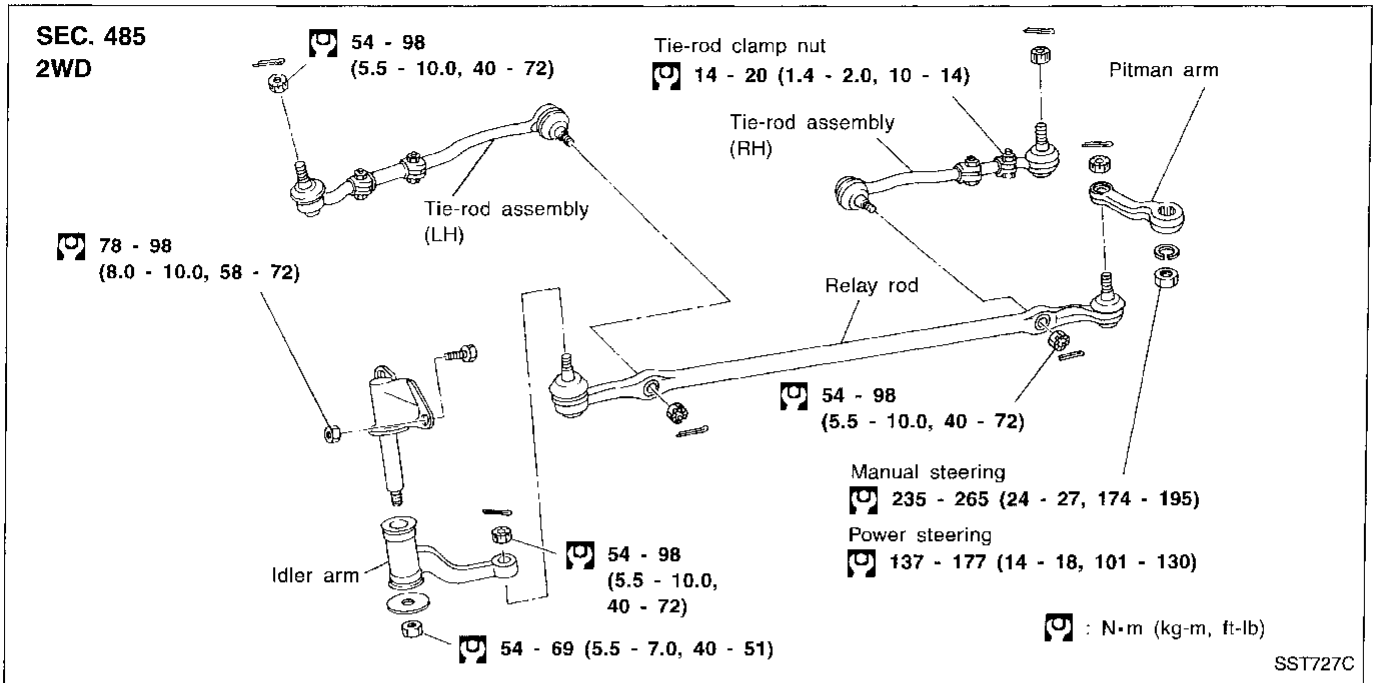

Remove pitman arm with Tool.

GI  
MA  
EM  
LC  
EC  
FE  
CL  
MT  
AT  
TF  
PD  
FA  
RA  
BR  
ST  
RS  
BT  
HA  
EL  
IDX



# STEERING LINKAGE

## Removal and Installation (Cont'd)

Remove tie-rod from knuckle arm with Tool.

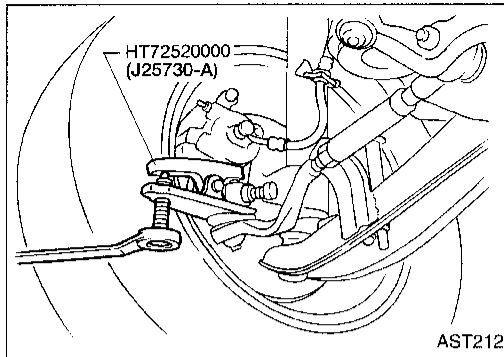

## Disassembly

### IDLER ARM ASSEMBLY

- Apply coat of multi-purpose grease to bushing.
- Press bushing into idler body, and insert shaft of idler bracket carefully until bushing protrudes.

### CROSS ROD AND TIE-ROD

1. When tie-rod ball joints and tie-rod bar are separated, adjust tie-rod length correctly. Adjustment should be done between ball stud centers.
2. Lock tie-rod clamp nut so that ball joint on outer ball stud is as follows with respect to that on inner ball stud.

L: Standard

343.9 mm (13.54 in) ... 2WD

297.6 mm (11.72 in) ... 4WD

### CAUTION:

Make sure that tie-rod bars are screwed into tie-rod tube more than 29 mm (1.14 in)...2WD, 22 mm (.87 in)...4WD.

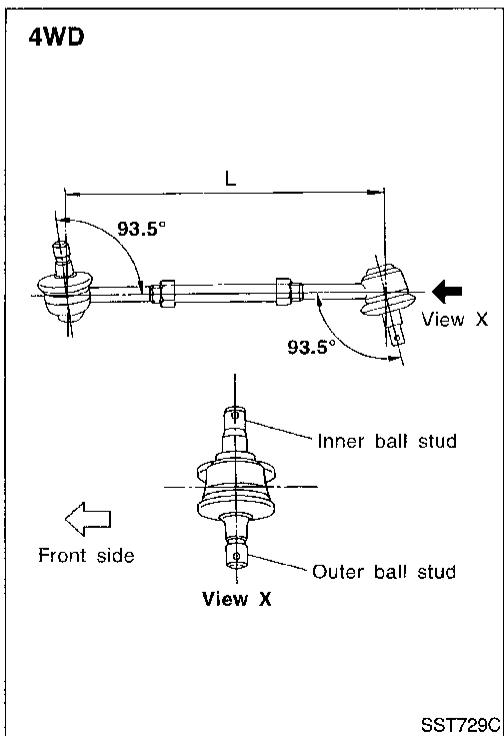
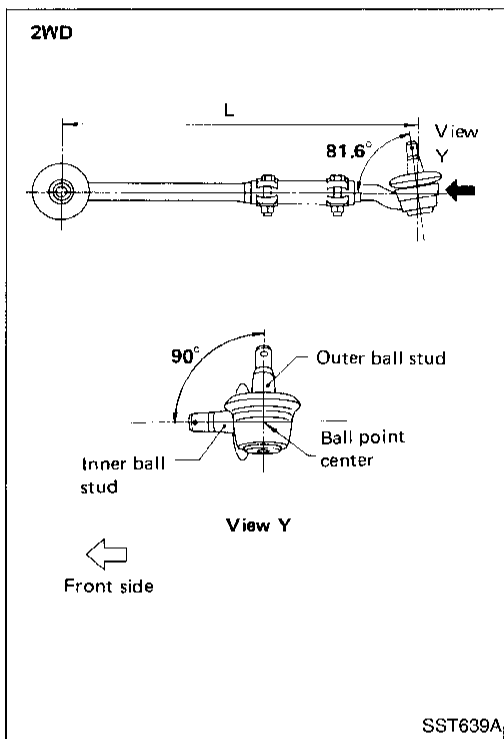

# STEERING LINKAGE

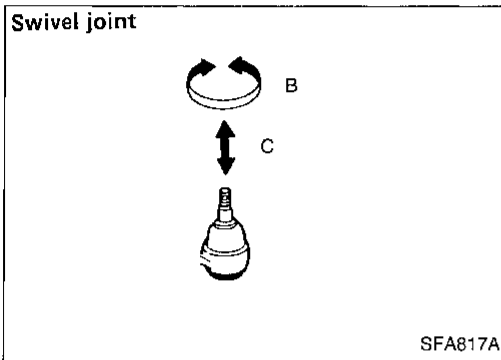
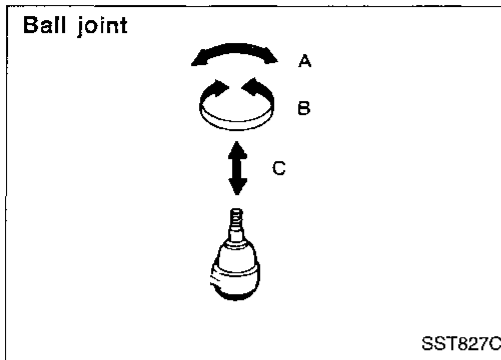

## Inspection

### BALL JOINT AND SWIVEL JOINT

1. Check joints for play. If ball or swivel stud is worn and play in axial direction is excessive or joint is hard to swing, replace as a complete unit.

**Swinging force (Measure point: Cotter pin hole) "A":**

**Ball joint**

15.7 - 147.1 N (1.6 - 15.0 kg, 3.5 - 33.1 lb)

**Rotating torque "B":**

**Ball joint**

0.5 - 4.9 N·m (5 - 50 kg-cm, 4.3 - 43.4 in-lb)

**Swivel joint**

1.0 - 5.9 N·m (10 - 60 kg-cm, 8.7 - 52.1 in-lb)

**Axial end play "C":**

**Ball joint and swivel joint**

0 mm (0 in)

2. Check condition of dust cover. If it is cracked excessively, replace as a complete unit.

### CAUTION:

**Be careful not to apply grease or oil to taper of joint.**

### IDLER ARM ASSEMBLY

- Check rubber bushing of idler arm for breakage, wear or play, and if necessary replace.
- Lubricate idler arm assembly with multi-purpose grease, if necessary.

### CROSS ROD AND TIE-ROD

Check tie-rod and cross rod for breakage, bends and cracks, and replace with a new one if necessary.

### FIXING LOCATION

- Check fixing location (nuts and cotter pins) for looseness, play or breakage.
- When looseness or play is found, check for wear on tapered portion of joints, gear arm of idler arm.
- When reassembling each joint, use new cotter pins.

GI

MA

EM

LC

EC

FE

CL

MT

AT

TF

PD

FA

RA

BR

ST

RS

BT

HA

EL

IDX

# SERVICE DATA AND SPECIFICATIONS (SDS)

## General Specifications

Steering column type (Collapsible)	Manual steering	Power steering	
	2WD	2WD	4WD
Steering gear type	VB66K	PB48S	PB59K
Turns of steering wheel on the vehicle (Lock-to-lock)	5.8	3.6	3.4
Steering gear ratio	24.4 - 26.8	16.5	15

Steering wheel axial play mm (in)	0 (0)
Steering wheel play mm (in)	35 (1.38) or less

## Inspection and Adjustment

### STEERING COLUMN LENGTH

Unit: mm (in)

Dimension "L"	863.1 - 866.7 (33.98 - 34.12)
---------------	-------------------------------

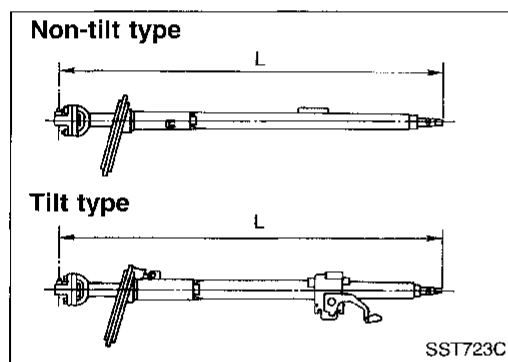

# SERVICE DATA AND SPECIFICATIONS (SDS)

## Inspection and Adjustment (Cont'd)

### MANUAL STEERING GEAR (Model: VB66K)

Worm bearing preload N-m (kg-cm, in-lb)	0.69 - 0.88 (7.0 - 9.0, 6.1 - 7.8)	
Steering gear turning torque N-m (kg-cm, in-lb)		
360° position from straight-ahead position	0.69 - 0.88 (7.0 - 9.0, 6.1 - 7.8)	
Straight-ahead position (As compared with steering wheel turned 360°)	0.20 - 0.39 (2.0 - 4.0, 1.7 - 3.5) higher	
Maximum turning torque	1.08 (11.0, 9.5)	
Backlash at pitman arm top end (in a straight-ahead position) mm (in)	0 - 0.1 (0 - 0.004)	
End play (Between sector shaft and adjusting screw) mm (in)	0.1 (0.004) or less	
Adjusting shim thickness	Thickness mm (in)	Part number
	1.95 (0.0768)	48129-84500
	2.00 (0.0787)	48130-84500
2.05 (0.0807)	48131-84500	
Oil capacity ℓ (Imp pt)	Approx. 0.62 (1-1/8)	

### STEERING LINKAGE

Applied model	2WD	4WD
Relay-rod swivel joint		
Rotating torque N-m (kg-cm, in-lb)	—	1.0 - 5.9 (10 - 60, 8.7 - 52.1)
Axial end play mm (in)	—	0 (0)
Tie-rod & relay-rod ball joint		
Swinging force at cotter pin hole N (kg, lb)	15.7 - 147.1 (1.6 - 15.0, 3.5 - 33.1)	
Rotating torque N-m (kg-cm, in-lb)	0.5 - 4.9 (5 - 50, 4.3 - 43.4)	
Axial end play mm (in)	0 (0)	
Tie-rod standard length (L) mm (in)	343.9 (13.54)	297.6 (11.72)

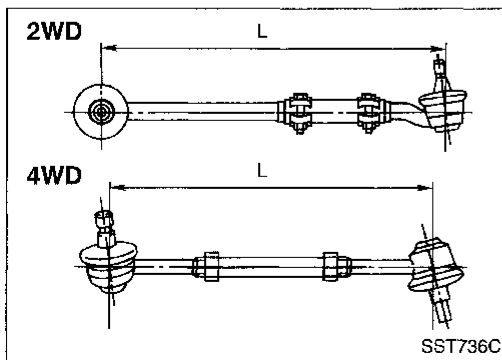

### POWER STEERING SYSTEM (Model: PB48S)

Steering wheel turning force (at 360° from neutral position and circumference of steering wheel) N (kg, lb)	24.5 - 29.4 (2.5 - 3.0, 5.5 - 6.6)	
Oil pump pressure kPa (bar, kg/cm <sup>2</sup> , psi)	7,649 - 8,238 (76.5 - 82.4, 78 - 84, 1,109 - 1,194) at idling	
Fluid capacity mℓ (Imp fl oz)	Approximately 900 - 1,000 (31.7 - 35.2)	
Normal operating temperature °C (°F)	60 - 80 (140 - 176)	
Steering gear turning torque N-m (kg-cm, in-lb)		
360° position from straight-ahead position	0.7 - 1.2 (7 - 12, 6.1 - 10.4)	
Straight-ahead position (As compared with steering wheel turned 360°)	0.1 - 0.4 (1 - 4, 0.9 - 3.5) higher	
Maximum turning torque	1.1 - 1.6 (11 - 16, 9.5 - 13.9)	
Backlash at pitman arm top end (in a straight-ahead position) mm (in)	0 - 0.1 (0 - 0.004)	
End play (Between sector shaft and adjusting screw) mm (in)	0.01 - 0.03 (0.0004 - 0.0012)	
Adjusting shim thickness	Thickness mm (in)	Part number
	1.575 - 1.600 (0.0620 - 0.0630)	48213-B0100
	1.550 - 1.575 (0.0610 - 0.0620)	48214-B0100
	1.525 - 1.550 (0.0600 - 0.0610)	48215-B0100
	1.500 - 1.525 (0.0591 - 0.0600)	48216-B0100
	1.475 - 1.500 (0.0581 - 0.0591)	48217-B0100
1.450 - 1.475 (0.0571 - 0.0581)	48218-B0100	

GI

MA

EM

LC

EC

FÈ

CL

MT

AT

TF

PD

FA

RA

BR

ST

RS

BT

HA

EL

IDX

# SERVICE DATA AND SPECIFICATIONS (SDS)

## Inspection and Adjustment (Cont'd)

### POWER STEERING SYSTEM

(Model: PB59K)

Steering wheel turning force (at 360° from neutral position and circumference of steering wheel) N (kg, lb)	39 (4, 9) or less
Oil pump pressure kPa (bar, kg/cm <sup>2</sup> , psi)	7,649 - 8,238 (76.5 - 82.4, 78 - 84, 1,109 - 1,194) at idling
Fluid capacity ml (Imp fl oz)	Approximately 1,000 - 1,100 (35.2 - 38.7)
Normal operating temperature °C (°F)	60 - 80 (140 - 176)
Steering gear turning torque N-m (kg-cm, in-lb)	
360° position from straight-ahead position	0.15 - 0.78 (1.5 - 8.0, 1.3 - 6.9)
Straight-ahead position (As compared with steering wheel turned 360°)	0.25 - 1.32 (2.5 - 13.5, 2.2 - 11.7) higher
Maximum turning torque	1.03 - 1.47 (10.5 - 15, 9.1 - 13.0)
Backlash at pitman arm top end (in straight- ahead position) mm (in)	0 - 0.1 (0 - 0.004)
End play (at sector shaft end in neutral position) mm (in)	0.1 (0.004) or less