



SECTION **RS** MA

CONTENTS

<p>PRECAUTIONS AND PREPARATION.....2</p> <p style="padding-left: 20px;">Supplemental Restraint System (SRS)</p> <p style="padding-left: 40px;">“AIR BAG”2</p> <p>SEAT BELTS3</p> <p style="padding-left: 20px;">Front Seat Belt.....4</p> <p style="padding-left: 20px;">Rear Seat Belt5</p> <p style="padding-left: 20px;">Seat Belt Inspection.....6</p> <p>SUPPLEMENTAL RESTRAINT SYSTEM (SRS).....9</p> <p style="padding-left: 20px;">Precautions for SRS “AIR BAG” Service.....9</p> <p style="padding-left: 20px;">Special Service Tools10</p> <p style="padding-left: 20px;">Description11</p> <p style="padding-left: 20px;">Passenger air bag deactivation switch.....11</p> <p style="padding-left: 20px;">SRS Component Parts Location12</p> <p style="padding-left: 20px;">Maintenance Items13</p> <p style="padding-left: 20px;">Diagnosis Sensor Unit and Crash Zone Sensor.....14</p> <p style="padding-left: 40px;">Removal And Installation14</p> <p style="padding-left: 60px;">Diagnosis sensor unit14</p> <p style="padding-left: 60px;">Crash zone sensor (4WD models).....14</p> <p style="padding-left: 20px;">Driver Air Bag Module and Spiral Cable15</p> <p style="padding-left: 20px;">Passenger Air Bag Module.....19</p> <p style="padding-left: 20px;">Passenger Air Bag Deactivation Switch.....21</p> <p style="padding-left: 20px;">Passenger Air Bag Deactivation Switch Lock Cylinder.....21</p>	<p style="padding-left: 20px;">Passenger Air Bag Deactivation Switch Indicator.....22</p> <p style="padding-left: 20px;">Disposal of Air Bag Module.....23</p> <p>TROUBLE DIAGNOSES — Supplemental Restraint System (SRS).....27</p> <p style="padding-left: 20px;">Trouble Diagnosis Introduction.....27</p> <p style="padding-left: 20px;">How to Perform Trouble Diagnoses for Quick and Accurate Repair.....30</p> <p style="padding-left: 20px;">Schematic31</p> <p style="padding-left: 20px;">Wiring Diagram –SRS–32</p> <p style="padding-left: 20px;">SRS Operation Check34</p> <p style="padding-left: 20px;"> Trouble Diagnoses with CONSULT35</p> <p style="padding-left: 20px;"> Trouble Diagnoses without CONSULT44</p> <p style="padding-left: 20px;">Trouble Diagnoses: “AIR BAG” Warning Lamp Does Not Turn Off48</p> <p style="padding-left: 20px;">Trouble Diagnoses: “AIR BAG” Warning Lamp Does Not Turn On49</p> <p style="padding-left: 20px;">Trouble Diagnoses: SRS Does Not Enter Diagnosis Mode Using Door Switch.....50</p> <p>COLLISION DIAGNOSIS.....51</p>
---------------------------------------------------------------------------------------------------------------------------------------------------------------------------------------------------------------------------------------------------------------------------------------------------------------------------------------------------------------------------------------------------------------------------------------------------------------------------------------------------------------------------------------------------------------------------------------------------------------------------------------------------------------------------------------------------------------------------------------------------------------------------------------------------------------------------------------------------------------------------------------------------------------------------------------------------------------------------------------------------------------------------------------------------------------------------------------------------------------------------------------------------------------------------------------------------------------------------------------------------------------------------------------------------------------------------------------------------------------------------------------------------------------------------------------------------------------------------------------------------------------------------	-----------------------------------------------------------------------------------------------------------------------------------------------------------------------------------------------------------------------------------------------------------------------------------------------------------------------------------------------------------------------------------------------------------------------------------------------------------------------------------------------------------------------------------------------------------------------------------------------------------------------------------------------------------------------------------------------------------------------------------------------------------------------------------------------------------------------------------------------------------------------------------------------------------------------------------------------------------------------------------------------------------------------------------------------------------------------------------------------------------------------------------------------------------------------------------------------------------------------------------------------------------------------------------------------------------------------------------------

When you read wiring diagrams:

- Read GI section, “HOW TO READ WIRING DIAGRAMS”.
- See EL section, “POWER SUPPLY ROUTING” for power distribution circuit.

When you perform trouble diagnoses, read GI section, “HOW TO FOLLOW FLOW CHART IN TROUBLE DIAGNOSES” and “HOW TO PERFORM EFFICIENT DIAGNOSIS FOR AN ELECTRICAL INCIDENT”.

RS

BT

HA

EL

IDX

Supplemental Restraint System (SRS) “AIR BAG”

The Supplemental Restraint System “AIR BAG”, used along with a seat belt, helps to reduce the risk or severity of injury to the driver and front passenger in a frontal collision. The Supplemental Restraint System consists of air bag modules (located in the center of the steering wheel and in the instrument panel on the passenger side), a diagnosis sensor unit, a crash zone sensor (4WD models), warning lamp, wiring harness and spiral cable.

The vehicle is equipped with a passenger air bag deactivation switch. Because no rear seat exists where a rear-facing child restraint can be placed, the switch is designed to turn off the passenger air bag so that a rear-facing child restraint can be used in the front passenger seat. The switch is located in the center of the instrument panel, near the ashtray. When the switch is turned to the ON position, the passenger air bag is enabled and could inflate in a frontal collision. When the switch is turned to the OFF position, the passenger air bag is disabled and will not inflate in a frontal collision. A passenger air bag OFF indicator on the instrument panel lights up when the passenger air bag is switched OFF. The driver air bag always remains enabled and is not affected by the passenger air bag deactivation switch.

WARNING:

- **To avoid rendering the SRS inoperative, which could increase the risk of personal injury or death in the event of a collision which would result in air bag inflation, all maintenance should be performed by an authorized NISSAN dealer.**
- **Improper maintenance, including incorrect removal and installation of the SRS, can lead to personal injury caused by unintentional activation of the system.**
- **Do not use electrical test equipment on any circuit related to the SRS unless instructed to in this Service Manual. SRS wiring harnesses are covered with yellow insulation either just before the harness connectors or on the complete harness, for easy identification.**
- **The vehicle is equipped with a passenger air bag deactivation switch which can be operated by the customer. When the passenger air bag is switched OFF, the passenger air bag is disabled and will not inflate in a frontal collision. When the passenger air bag is switched ON, the passenger air bag is enabled and could inflate in a frontal collision. After SRS maintenance or repair, make sure the passenger air bag deactivation switch is in the same position (ON or OFF) as when the vehicle arrived for service.**

SEAT BELTS

CAUTION:

- Do not disassemble buckle or seat belt assembly.
- Replace anchor bolts if they are deformed or worn out.
- Never oil tongue and buckle.
- If any component of seat belt assembly is questionable, do not repair. Replace the seat belt assembly.
- If webbing is cut, frayed, or damaged, replace seat belt assembly.
- When replacing seat belt assembly, use a genuine NISSAN seat belt assembly.
- After any collision, inspect all seat belt assemblies, including retractors and other attached hardware.

GI

MA

EM

LC

EC

FE

CL

MT

AT

TF

PD

FA

RA

BR

ST

RS

BT

HA

EL

IDX

SEAT BELTS

Front Seat Belt

SEC. 868

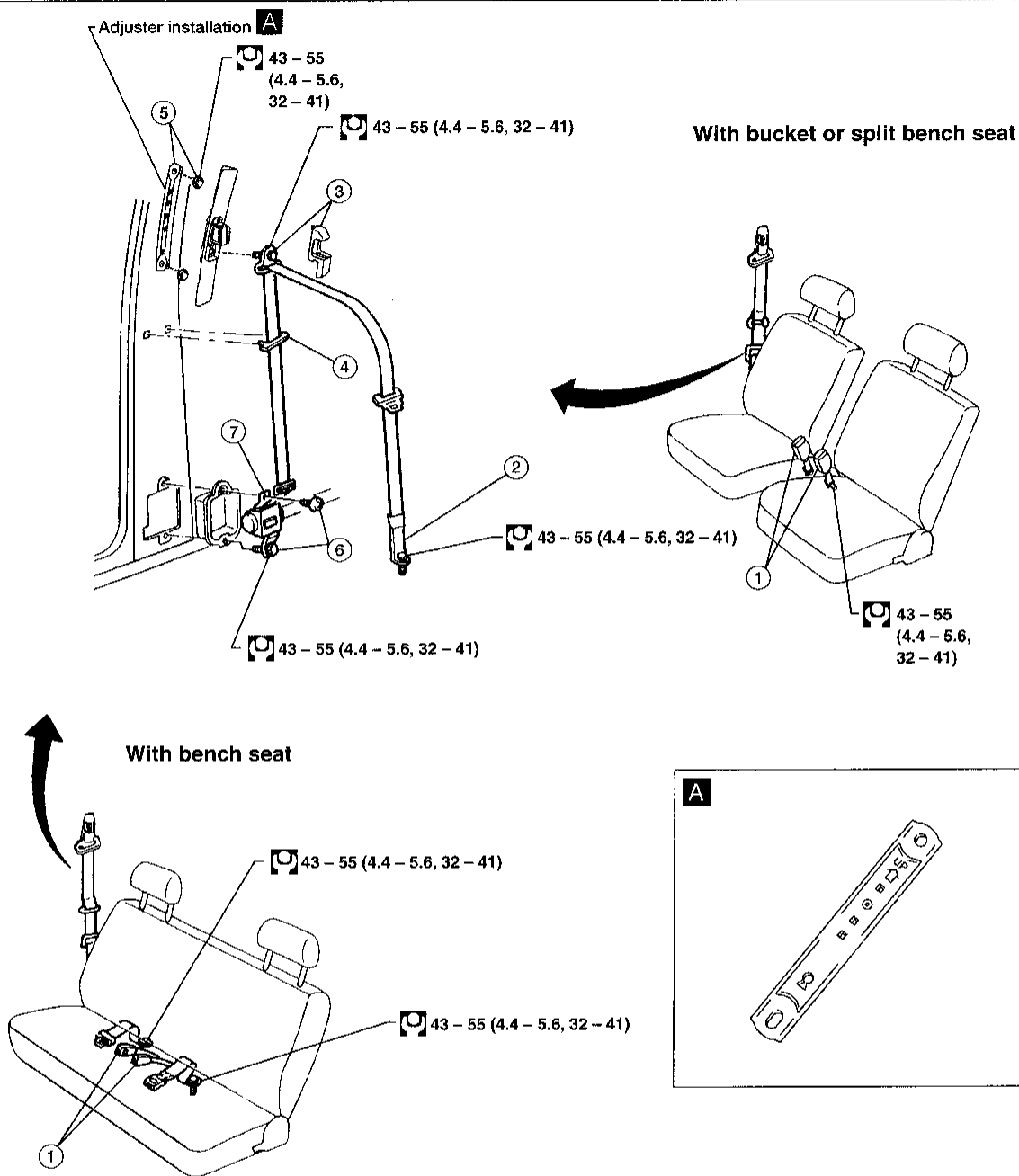

 : N·m (kg·m, ft·lb)

ARS220

REMOVAL

Remove front seat. Refer to BT section ("Front Seat", "SEAT").

- ① Remove buckle.
- ② Remove floor anchor bolt.
- ③ Remove adjuster cover and upper guide loop anchor bolt.
For King Cab models, remove jump seat. Refer to BT section, ("Rear Seat", "SEAT").
Remove rear pillar lower and upper garnishes.
- ④ Remove guide plate.
- ⑤ Remove two adjuster bolts and adjuster assembly. **A**
- ⑥ Remove retractor bolt and screw.
- ⑦ Remove retractor.

SEAT BELTS

Rear Seat Belt

SEC. 869

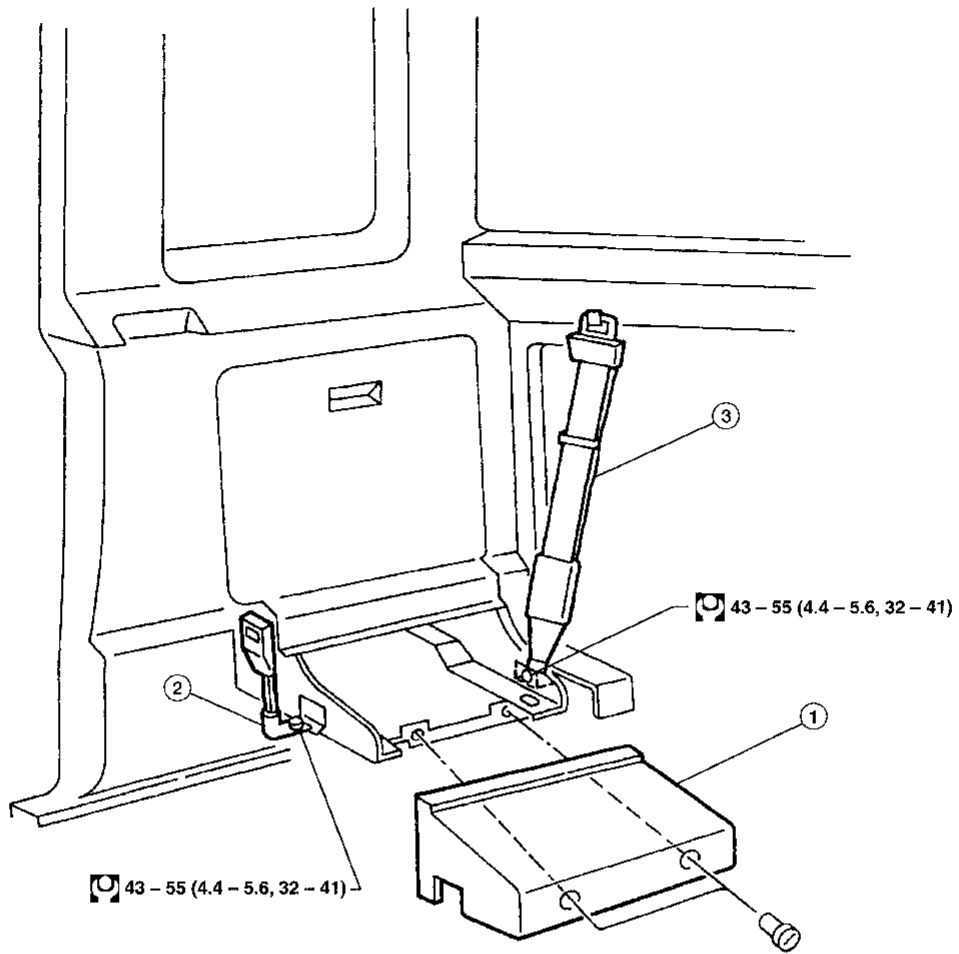

ARS221

REMOVAL

- ① Remove underseat storage.
- ② Remove buckle.
- ③ Remove seat belt anchor bolt.

GI
MA
EM
LC
EC
FE
CL
MT
AT
TF
PD
FA
RA
BR
ST
RS
BT
HA
EL
IDX

SEAT BELTS

Seat Belt Inspection

AFTER A COLLISION

WARNING:

Inspect all seat belt assemblies including retractors and attaching hardware after any collision. NISSAN recommends that all seat belt assemblies in use during a collision be replaced unless the collision was minor and the belts show no damage and continue to operate properly. Failure to do so could result in serious personal injury in an accident. Seat belt assemblies not in use during a collision should also be replaced if either damage or improper operation is noted.

Replace any seat belt assembly if:

- The seat belt was in use at the time of a collision (except for minor collisions when the belts, retractors and buckles show no damage and continue to operate properly).
- The seat belt was damaged in an accident (i.e. torn webbing, bent retractor or guide, etc.).
- The seat belt attaching point was damaged in an accident. Inspect the seat belt attaching area for damage or distortion and repair as necessary before installing a new seat belt assembly.

PRELIMINARY CHECKS

1. Check the seat belt warning lamp/chime for proper operation as follows:
 - a. Switch ignition ON. The seat belt warning lamp should illuminate. Also, the seat belt warning chime should sound for about 7 seconds.
 - b. Fasten driver's seat belt. The seat belt warning lamp should go out and the chime (if sounding) should stop.
2. Check that the seat belt retractor, seat belt anchor and buckle bolts are securely attached.
3. Check the shoulder seat belt guide and shoulder belt height adjuster for front seats. Ensure guide swivels freely and that belt lays flat and does not bind in guide. Ensure height adjuster operates properly and holds securely.

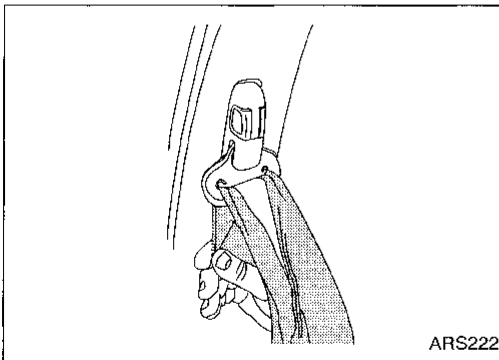

4. Check retractor operation including:
 - a. Fully extend the seat belt webbing and check for twists, tears or other damage.
 - b. Allow the seat belt to retract. Ensure that belt returns smoothly and completely into the retractor. If the seat belt does not return smoothly, wipe the inside of the loops with a clean paper cloth, etc. because dirt built up in the loops of the upper anchors can cause the seat belts to retract slowly.
 - c. Fasten the seat belt. Pull firmly on belt and buckle to ensure belt remains latched. Unfasten seat belt. Ensure belt releases freely and buckle button returns to original position.
5. For non-retractable seat belts, check that the seat belts are accessible. Check seat belt webbing for twists, tears or other damage. Fasten the seat belt. Pull firmly on belt and buckle to ensure belt remains latched. Unfasten seat belts. Ensure belt releases freely and buckle button returns to original position.
6. Repeat steps above as necessary to check the other seat belts.

SEAT BELTS

Seat Belt Inspection (Cont'd)

SEAT BELT RETRACTOR ON-VEHICLE CHECK

Emergency locking retractors (ELR) and Automatic locking retractors (ALR)

NOTE:

All seat belt retractors are of the Emergency Locking (ELR) type. In an emergency (sudden stop) the retractor will lock and prevent the belt from extending any further. All outboard 3-point type seat belt retractors except the driver's seat belt also have an Automatic Locking (ALR) mode. The ALR mode (also called child restraint mode) is used when installing child seats in outboard seating positions. The ALR mode is activated when the seat belt is fully extended. When the belt is then retracted partially, the ALR mode automatically locks the seat belt in a specific position so the belt cannot be extended any further. To cancel the ALR mode, allow the seat belt to fully wind back into the retractor.

Check the seat belt retractors using the following test(s) to determine if a retractor assembly is operating properly.

ELR function stationary check

Grasp the shoulder belt and pull forward quickly. The retractor should lock and prevent the belt from extending further.

ALR function stationary check

1. Pull out entire length of seat belt from retractor until a click is heard.
2. Retract the belt partially; a clicking noise should be heard as the belt retracts indicating retractor is in the automatic locking (ALR) mode.
3. Grasp the seat belt and try to pull out of retractor. Belt must lock and not extend further. If NG, replace the retractor assembly.
4. Allow the entire length of belt to retract to cancel the automatic locking mode.

ELR function moving check (all outboard seating positions)

WARNING:

Perform the following test in a safe, open area clear of other vehicles and obstructions (for example, a large, empty parking lot). Road surface must be paved and dry. DO NOT perform the following test on wet or gravel roads or on public streets and highways. This could result in an accident and serious personal injury. The driver and passenger must be prepared to brace themselves in the event the retractor does not lock.

1. Fasten driver's seat belt. Buckle a passenger into the seat for the belt that is to be tested.
2. Proceed to the designated safe area.
3. Drive the vehicle at approximately 16 km/h (10 MPH). Notify any passengers of a pending sudden stop. The driver and passenger must be prepared to brace themselves in the event the retractor does not lock. Apply brakes firmly and make a very hard stop.

During stop, seat belts should lock and not extend. If the seat belt retractor assembly does not lock, perform the retractor off-vehicle check.

GI

MA

EM

LC

EC

FE

CL

MT

AT

TF

PD

FA

RA

BR

ST

RS

BT

HA

EL

IDX

SEAT BELTS

Seat Belt Inspection (Cont'd)

SEAT BELT RETRACTOR OFF-VEHICLE CHECK

1. Remove the seat belt retractor assembly.
2. Slowly pull out belt while tilting the retractor assembly forward from the mounted position as shown in the illustration.

15 degrees or less tilt: Belt can be pulled out.

35 degrees or more tilt: Belt locks and cannot be pulled out.

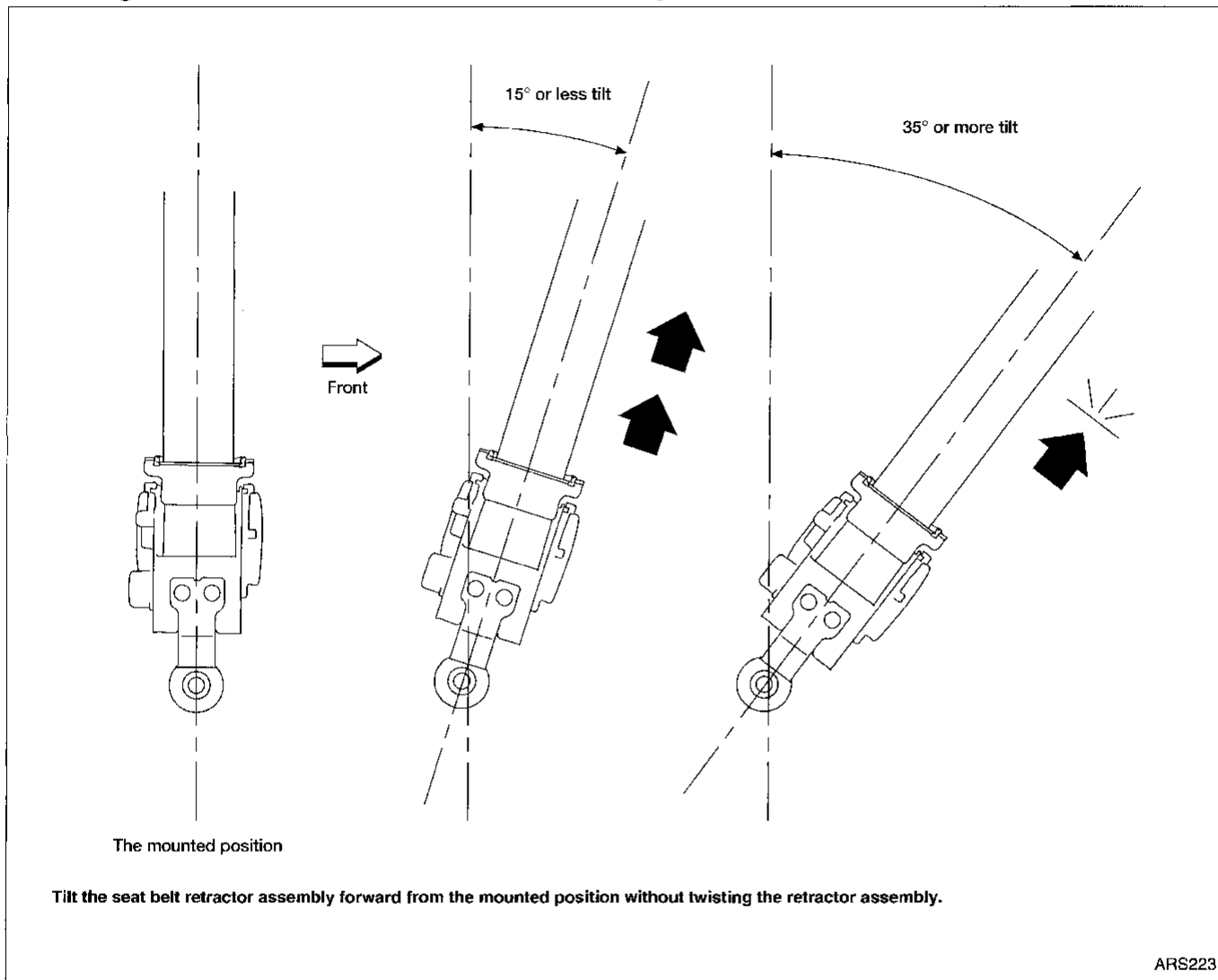

If NG replace the retractor assembly.

Precautions for SRS “AIR BAG” Service

- Do not use electrical test equipment on any circuit related to the SRS unless instructed to in this Service Manual. SRS wiring harnesses are covered with yellow insulation either just before the harness connectors or on the complete harness, for easy identification.
- Before servicing the SRS, turn ignition switch OFF, disconnect both battery cables and wait at least 3 minutes.
For approximately 3 minutes after the cables are removed, it is still possible for the air bag to deploy. Therefore, do not work on any air bag system connectors or wires until at least 3 minutes have passed.
- Diagnosis sensor unit and crash zone sensor (4WD models) must always be installed with forward mark “↖” pointing toward the front of the vehicle for proper operation. Also check diagnosis sensor unit for cracks, deformities and rust before installation and replace if necessary.
- The rotation of the spiral cable is limited. The spiral cable must be aligned in the neutral position. If the steering gear must be removed, set the front wheels in the straight-ahead direction. Do not rotate the steering column while the steering gear is removed to avoid damaging the spiral cable.
- Handle air bag modules carefully. Always place them with the pad side facing upward.
- Do not use old special bolts after removing any SRS parts; replace with new special bolts. Conduct self-diagnosis to check entire SRS for proper operation.
- If front of vehicle is damaged in a collision, always check the crash zone sensor (4WD models) and the wiring harness.
- After air bag inflates, the instrument panel assembly should be replaced if damaged.
- After SRS maintenance or repair, make sure the passenger air bag deactivation switch is in the same position (ON or OFF) as when the vehicle arrived for service.

GI

MA

EM

LC

EC

FE

CL

MT

AT

TF

PD

FA

RA

BR

ST

RS

BT

HA

EL

IDX

SUPPLEMENTAL RESTRAINT SYSTEM (SRS)

Special Service Tools

The actual shapes of Kent-Moore tools may differ from those of special service tools illustrated here.

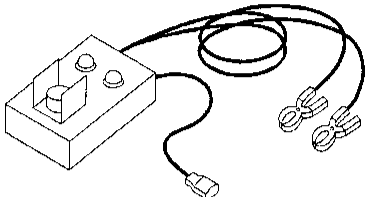
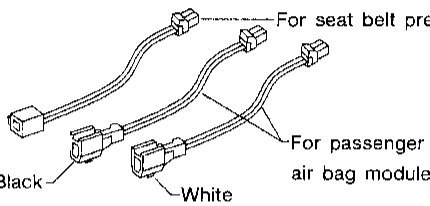
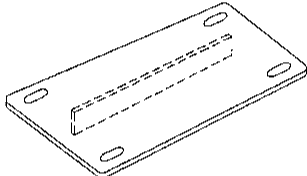
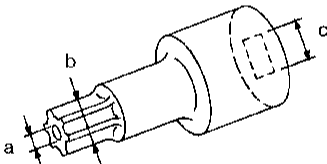
Tool number (Kent-Moore No.) Tool name	Description
KV991072S0 (J38381-KIT) Air bag deployment kit KV99106400 (J38381) Deployment tool	 <p data-bbox="1019 331 1312 359">Disposing of air bag module</p> <p data-bbox="451 520 509 548">NT357</p>
KV991065S0 (J38381-30) Deployment tool adapters	 <p data-bbox="743 575 997 602">For seat belt pre-tensioner</p> <p data-bbox="760 701 899 758">For passenger air bag module</p> <p data-bbox="461 743 521 770">Black</p> <p data-bbox="639 743 699 770">White</p> <p data-bbox="451 785 509 812">NT353</p>
KV99105300 (J41246) Air bag module bracket	 <p data-bbox="1019 835 1321 863">Anchoring the air bag module</p> <p data-bbox="451 1010 509 1037">NT354</p>
HT61961000 and HT62152000 combined (J38219) *Special torx bit	 <p data-bbox="1019 1058 1442 1115">Use for special bolts [TAMPER RESISTANT TORX (Size T50)]</p> <p data-bbox="1019 1163 1192 1190">a: 3.5 (0.138) dia.</p> <p data-bbox="1019 1190 1321 1218">b: 8.5 - 8.6 (0.335 - 0.339) dia.</p> <p data-bbox="1019 1218 1256 1245">c: approx. 10 (0.39) sq.</p> <p data-bbox="451 1255 509 1283">NT361</p> <p data-bbox="1344 1255 1474 1283">Unit: mm (in)</p>

*: Special tool or commercial equivalent

Description

2WD models

The diagnosis sensor unit will deploy the air bags if the G-sensor activates simultaneously with the safing sensor while the ignition switch is ON. The passenger air bag does not deploy when the passenger air bag deactivation switch is turned to the OFF position.

4WD models

The diagnosis sensor unit will deploy the air bags if the G-sensor and/or the crash zone sensor activates simultaneously with the safing sensor while the ignition switch is ON. The passenger air bag does not deploy when the passenger air bag deactivation switch is turned to the OFF position.

Ignition	Crash zone sensor (4WD models only)	Diagnosis sensor unit		Passenger air bag deactivation switch position	Driver air bag	Passenger air bag
		G-sensor	Safing sensor			
ON	—	ON	ON	ON	Deploy	Deploy
				OFF	Deploy	Not deploy
ON	ON	—	ON	ON	Deploy	Deploy
				OFF	Deploy	Not deploy
ON	ON	ON	ON	ON	Deploy	Deploy
				OFF	Deploy	Not deploy

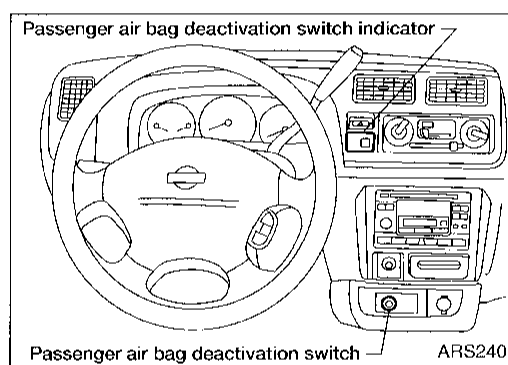

Passenger air bag deactivation switch

The vehicle is equipped with a passenger air bag deactivation switch which can be operated by the customer. When the switch is turned to the ON position, the passenger air bag is enabled and could inflate in a frontal collision. When the switch is turned to the OFF position, the passenger air bag is disabled and will not inflate in a frontal collision.

After turning the ignition switch ON, a passenger air bag deactivation switch indicator illuminates on the instrument panel for bulb check. The indicator will stay lit if the passenger air bag deactivation switch is in the OFF position. If the passenger air bag deactivation switch is in the ON position, the indicator will turn off after about 7 seconds.

After SRS maintenance or repair, make sure the passenger air bag deactivation switch is in the same position (ON or OFF) as when the vehicle arrived for service.

IGN OFF → ON

Passenger air bag deactivation switch position	Passenger air bag deactivation switch indicator	Passenger air bag deployment
ON	Turns off within 7 seconds	Enabled
OFF	Stays lit	Disabled

If the passenger air bag deactivation switch indicator operation does not correspond to ON/OFF operation of the passenger air bag deactivation switch, perform self-diagnoses for SRS and repair according to the self-diagnostic failure. Refer to "TROUBLE DIAGNOSES — Supplemental Restraint System (SRS)", "SRS Operation Check", RS-34.

If no self-diagnostic failure is detected, replace the passenger air bag deactivation switch including the key cylinder.

SUPPLEMENTAL RESTRAINT SYSTEM (SRS)

Description (Cont'd)

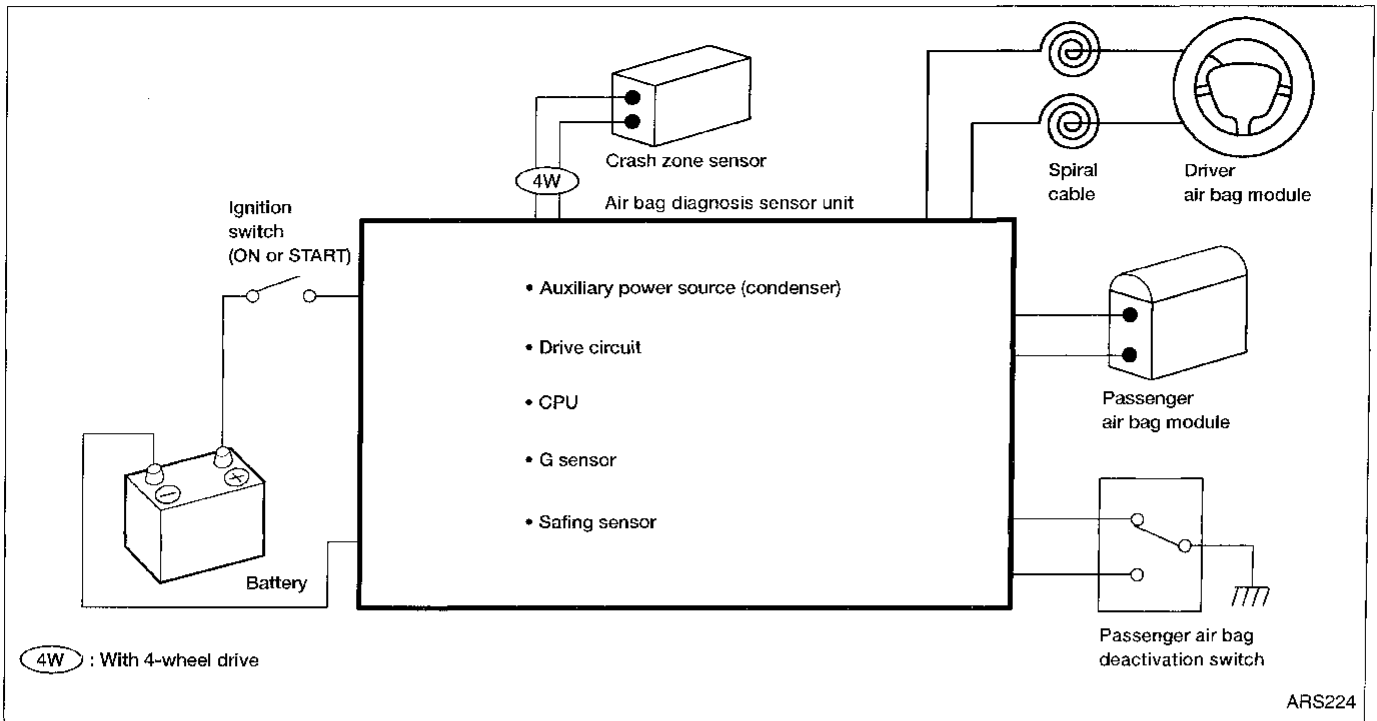

SRS Component Parts Location

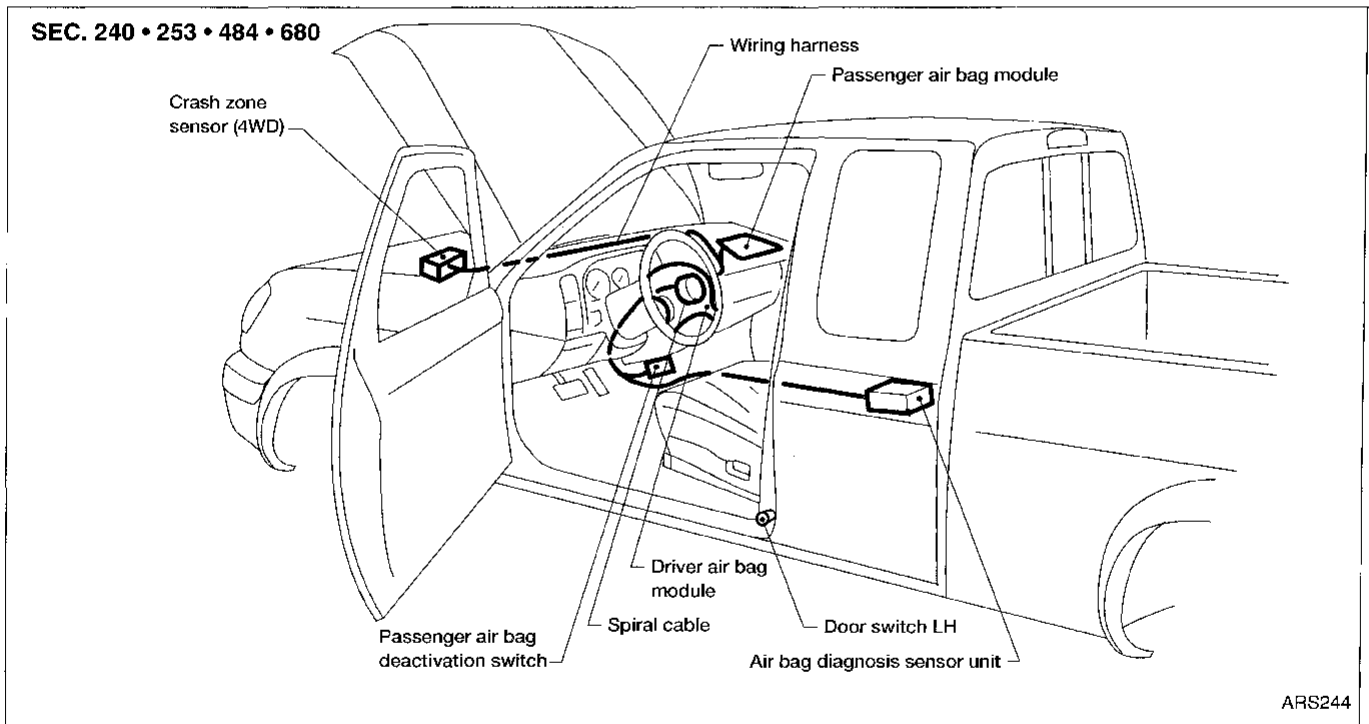

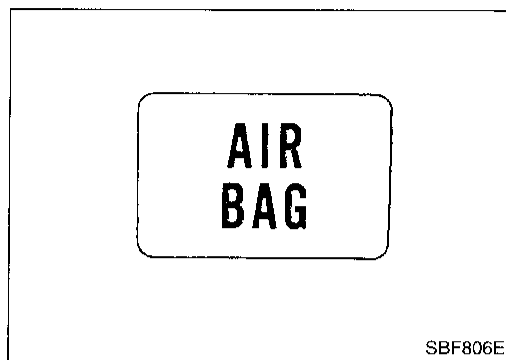

Maintenance Items

1. Check "AIR BAG" warning lamp operation

After turning the ignition key ON, "AIR BAG" warning lamp illuminates. The "AIR BAG" warning lamp will turn off after about 7 seconds if no malfunction is detected.

If any of the following "AIR BAG" warning lamp conditions occur, immediately check the air bag system. Refer to RS-34.

 - The warning lamp does not illuminate when the ignition switch is turned ON.
 - The warning lamp does not turn off about 7 seconds after the ignition switch is turned ON.
 - The warning lamp turns off about 7 seconds after the ignition switch is turned ON, but it turns on again or blinks.

2. Visually check SRS components
 - a. Crash zone sensor (4WD models)
 - Check crash zone sensor to ensure the arrow marks face the front of the vehicle.
 - Check body and sensor bracket for deformities and rust.
 - Check sensor case for dents, cracks, deformities and rust.
 - Check sensor harness for binding, connector for damage and terminals for deformities.
 - b. Air bag diagnosis sensor unit
 - Check air bag diagnosis sensor unit and bracket for dents, cracks and deformities.
 - Check connectors for damage and terminals for deformities.
 - c. Air bag modules, steering wheel and instrument panel
 - Remove driver air bag module from steering wheel. Check harness cover and connectors for damage, terminals for deformities, and harness for binding.
 - Install driver air bag module in steering wheel to check fit or alignment with the wheel.
 - Check steering wheel for excessive free play.
 - Remove passenger air bag module. Check harness cover and connectors for damage, terminals for deformities, and harness for binding. Check the bracket for deformities and rust.
 - Install passenger air bag module in instrument panel to check fit or alignment with the instrument panel.
 - d. Spiral cable
 - Check spiral cable for dents, cracks, and deformities.
 - Check connectors and protective tape for damage.
 - Check steering wheel for noise, binding and heavy operation.
 - e. Passenger air bag deactivation switch
 - Check passenger air bag deactivation switch for damage.
 - Check harness for binding, connector for damage and terminals for deformities.
 - f. Main harness and air bag harness
 - Check connectors for poor connections, damage, and terminals for deformities.
 - Check harnesses for binding, chafing and cuts.

CAUTION:

Replace previously used special bolts with new ones.

GI
MA
EM
LC
EC
FF
CL
MT
AT
TF
PD
FA
RA
BR
ST
RS
BT
HA
EL
IDX

Diagnosis Sensor Unit and Crash Zone Sensor

CAUTION:

- Before servicing SRS, turn the ignition switch OFF, disconnect both battery cables and wait at least 3 minutes.
- The special bolts are coated with bonding agent while the other bolt is for ground. Do not use old bolts after removal; replace with new coated bolts.
- Check air bag diagnosis sensor unit for proper installation. Make sure that there are no deformities, dents, cracks or rust. If there are any visible signs of damage, replace with a new one.
- Check air bag diagnosis sensor unit brackets to ensure they are free of deformities and rust.
- Replace air bag diagnosis sensor unit if it has been dropped or sustained an impact.
- Check crash zone sensor (4WD models) for proper installation. Make sure that there are no deformities, dents, cracks or rust. If there are any visible signs of damage, replace the crash zone sensor.
- Check crash zone sensor bracket (4WD models) to ensure that it is free of deformities and rust.

REMOVAL AND INSTALLATION

Diagnosis sensor unit

1. Disconnect driver and passenger air bag module connectors.
2. Remove console box. Refer to BT section ("INSTRUMENT PANEL").
3. Disconnect air bag diagnosis sensor unit connector.
4. Remove bolts from air bag diagnosis sensor unit. Use TAMPER RESISTANT TORX (Size T50) to remove special bolts.
5. Remove the air bag diagnosis sensor unit.

NOTE:

- To install, reverse the removal procedure.
- After replacement, perform self-diagnosis for SRS. Refer to "TROUBLE DIAGNOSES — Supplemental Restraint System (SRS)", "SRS Operation Check", RS-34.

CAUTION:

Air bag diagnosis sensor unit must always be installed with forward mark "⬆" pointing towards the front of the vehicle for proper operation. Also check air bag diagnosis sensor unit for cracks, deformities and rust before installation and replace as required.

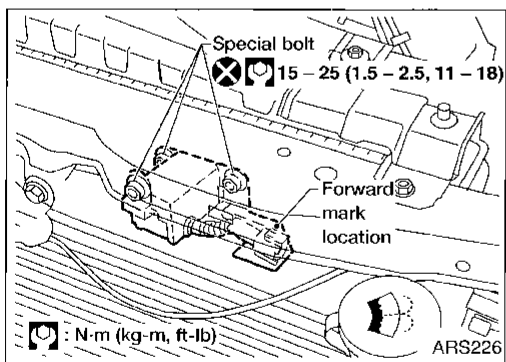
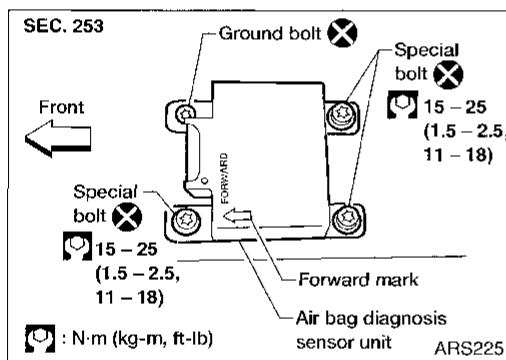

Crash zone sensor (4WD models)

1. Disconnect driver and passenger air bag module connectors.
2. Remove front grille. Refer to BT section ("BODY FRONT END").
3. Disconnect crash zone sensor connector.
4. Using the TAMPER RESISTANT TORX (Size T50), remove the three special bolts. The crash zone sensor can then be removed.

NOTE:

- To install, reverse removal procedure.
- After replacement, perform Self-diagnosis for SRS. Refer to "TROUBLE DIAGNOSES — Supplemental Restraint System (SRS)", "SRS Operation Check", RS-34.

Driver Air Bag Module and Spiral Cable

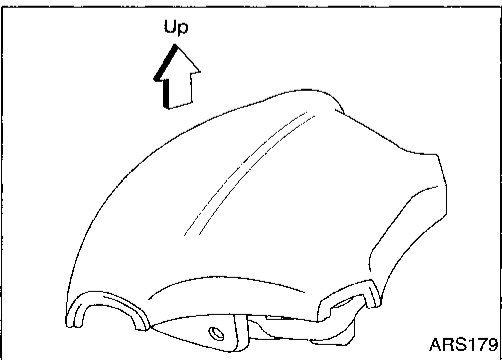
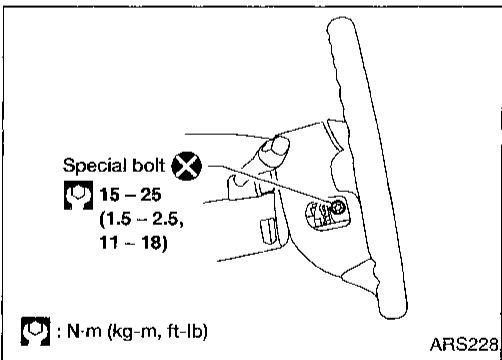
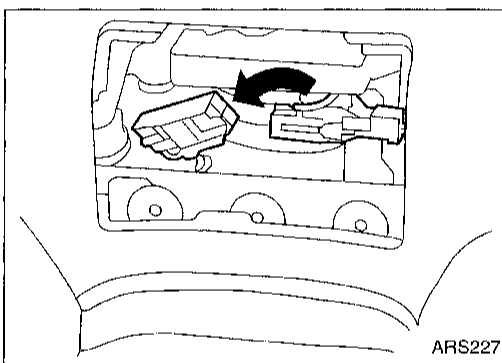
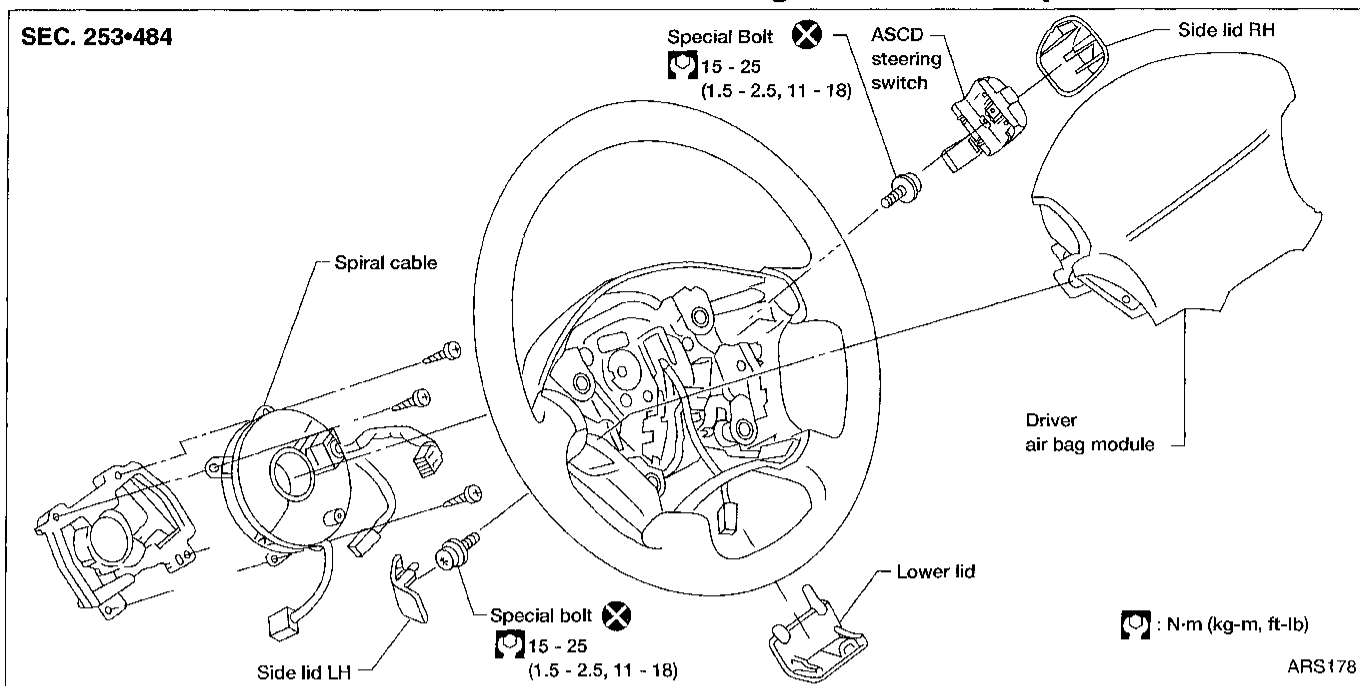

REMOVAL

CAUTION:

- Before servicing SRS, turn the ignition switch OFF, disconnect both battery cables and wait at least 3 minutes.
- Always work from the side of an air bag module.

1. Remove lower lid from steering wheel, and disconnect driver air bag module connector.

2. Remove side lids. Using the TAMPER RESISTANT TORX (Size T50), remove left and right special bolts. Driver air bag module can then be removed.

CAUTION:

- Always place air bag module with pad side facing upward.
- Do not attempt to disassemble air bag module.
- The special bolts are coated with bonding agent. Do not use old bolts after removal; replace with new coated bolts.

GI

MA

EM

LC

EC

FE

GL

MT

AT

TF

PD

FA

RA

BR

ST

RS

BT

HA

EL

IDX

SUPPLEMENTAL RESTRAINT SYSTEM (SRS)

Driver Air Bag Module and Spiral Cable (Cont'd)



- Do not drop or impact air bag module. If any portion is deformed or cracked, replace the module.
- Do not expose the air bag module to temperatures exceeding 90°C (194°F).
- Do not allow oil, grease or water to come in contact with the air bag module.

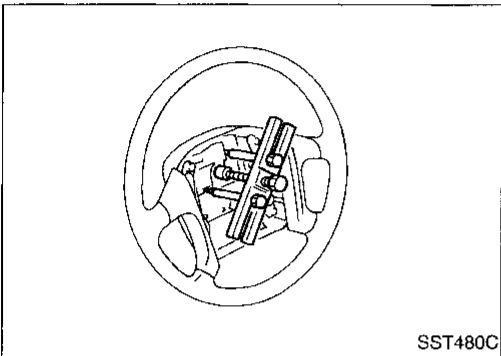

3. Set steering wheel in the neutral position.
4. Disconnect horn connector and remove steering wheel nut.
5. Using steering wheel puller, remove steering wheel. Be careful not to over-tighten puller bolt on steering wheel.

CAUTION:

Do not tap or bump the steering wheel.

6. Remove steering column covers.
7. Disconnect spiral cable from air bag harness.

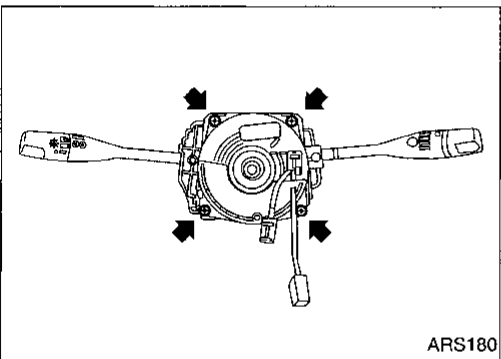

8. Remove the four spiral cable retaining screws. The spiral cable can then be removed.

CAUTION:

- Do not attempt to disassemble spiral cable.
- Do not apply lubricant to the spiral cable.

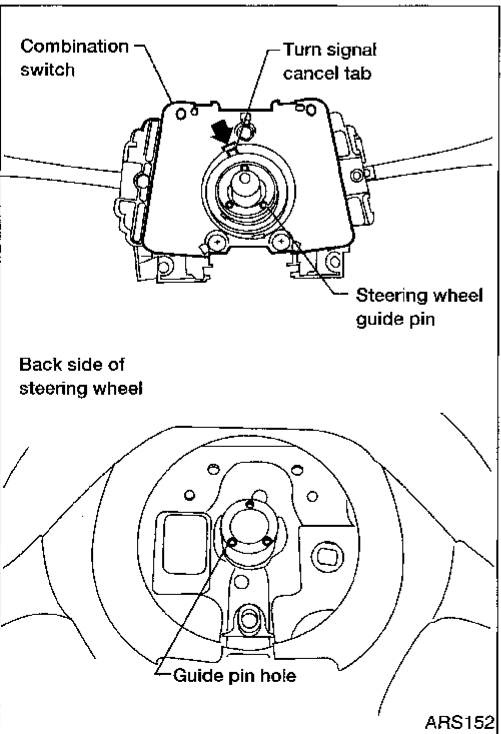

INSTALLATION

1. Set the front wheels in the straight-ahead position.
2. Align the turn signal cancel tab with the notch of the combination switch as shown.

SUPPLEMENTAL RESTRAINT SYSTEM (SRS)

Driver Air Bag Module and Spiral Cable (Cont'd)

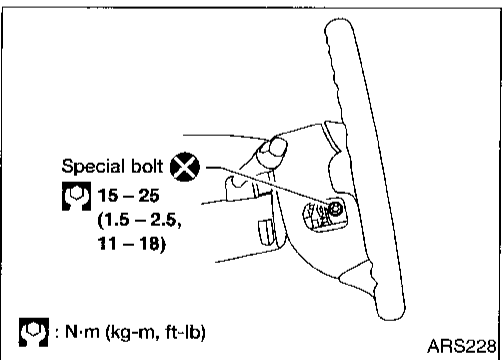
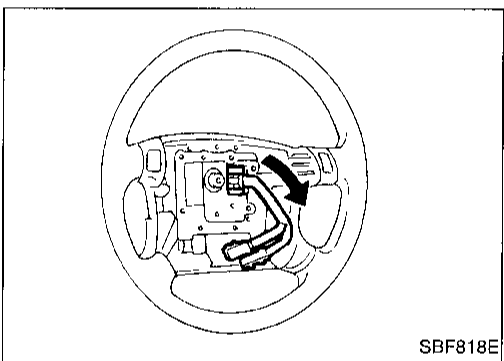
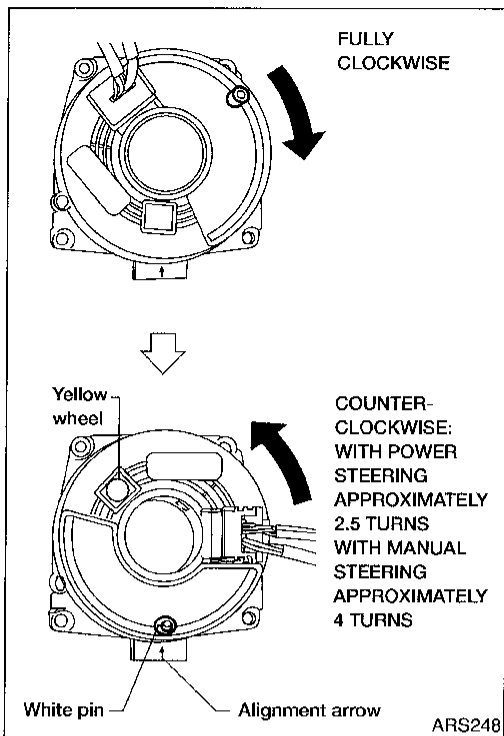

3. Set the front wheels in the straight-ahead position.
4. Rotate the spiral cable fully clockwise until tight.
5. Rotate the spiral cable counterclockwise as specified below and align white pin with arrow on housing.

Specified turns for spiral cable:

Applied model	Specified turns from neutral position
With power steering	Approx. 2.5
Without power steering	Approx. 4

- When spiral cable is centered, white pin is aligned with arrow on housing and yellow wheel shows in window.

CAUTION:

The spiral cable may snap during steering operation if the spiral cable is installed improperly. Also, with the steering linkage disconnected, the spiral cable may snap by turning the steering wheel beyond the specified number of turns. Always perform SRS Self-diagnosis after installing the air bag module.

6. Connect spiral cable to air bag harness and tighten screws. Install steering column covers.

7. Install steering wheel, setting spiral cable pin guide, and pull spiral cable connectors through.
8. Connect horn connector and engage spiral cable with pawls in steering wheel.
9. Tighten steering wheel nut.

: 29 - 39 N·m (3.0 - 4.0 kg-m, 22 - 29 ft-lb)

10. Position driver air bag module and tighten with new special bolts.
11. Connect driver air bag module connector.
12. Install all lids.
13. Connect both battery cables.
14. Conduct Self-diagnosis to ensure entire SRS operates properly (Use CONSULT or warning lamp check.). Turn the steering wheel fully to the right and left to check that the spiral cable is set in the neutral position.
15. If air bag warning lamp blinks (at the User mode), it shows the spiral cable may be snapped due to its improper position. Perform Self-diagnosis again. (Use CONSULT or warning lamp check.) If a malfunction is detected, replace the spiral cable with a new one.

NOTE:

- After replacement, perform Self-diagnosis for SRS. Refer to "TROUBLE DIAGNOSES — Supplemental Restraint System (SRS)", "SRS Operation Check", RS-34.

GI

MA

EM

LC

EC

FE

CL

MT

AT

TF

PD

FA

RA

BR

ST

RS

BT

HA

EL

IDX

NOTES

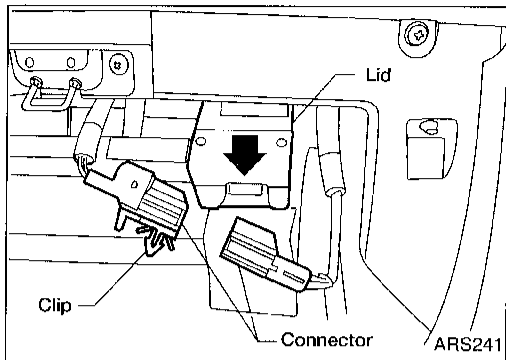

Passenger Air Bag Module

REMOVAL

CAUTION:

- Before servicing SRS, turn the ignition switch OFF, disconnect both battery cables and wait for at least 3 minutes.
 - Always work from the side of an air bag module.
1. Open glove box assembly.
 2. Open lid of instrument panel lower passenger side, inside glove box.
 3. Remove passenger air bag module connector clip from lid.
 4. Disconnect passenger air bag module connector.
 5. Remove glove box and instrument panel lower passenger side. Refer to BT section ("INSTRUMENT PANEL").

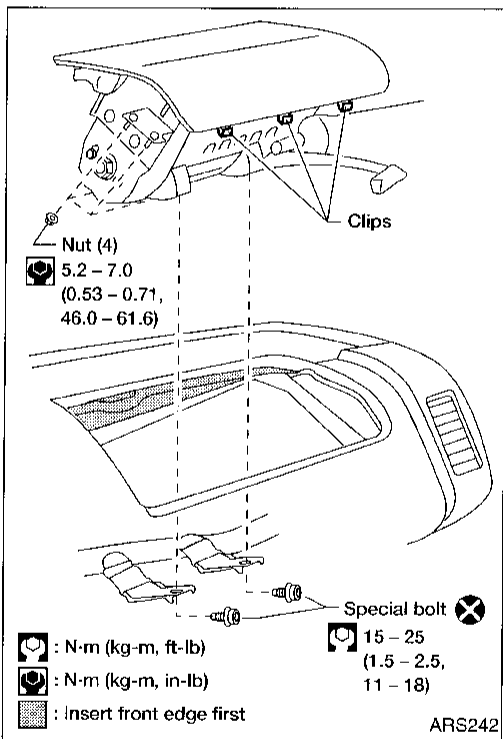

6. Using TAMPER RESISTANT TORX (Size T50), remove the two special bolts.
7. Remove four mounting nuts.
8. Remove passenger air bag module by releasing the clips from the top of the instrument panel.

- Air bag module is heavy and should be supported using both hands during removal.

CAUTION:

- Always place air bag module with pad side facing upward.
- Do not attempt to disassemble air bag module.
- The special bolts are coated with a bonding agent. Do not use old bolts after removal; replace with new coated bolts.
- Do not insert any foreign objects (screwdriver, etc.) into air bag module connector.

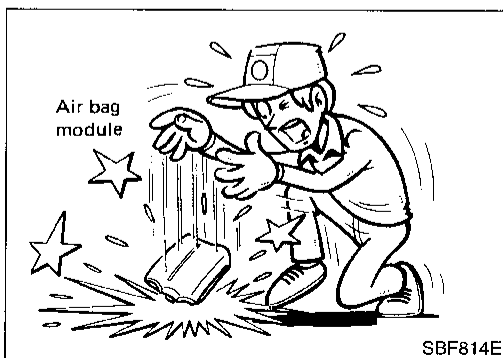

- Do not drop or impact air bag module. If any portion is deformed or cracked, replace the module.
- Do not expose the air bag module to temperatures exceeding 90°C (194°F).
- Do not allow oil, grease or water to come in contact with the air bag module.

GI
 MA
 EM
 LC
 EC
 FE
 CL
 MT
 AT
 TF
 PD
 FA
 RA
 BR
 ST
 RS
 BT
 HA
 EL
 IDX

SUPPLEMENTAL RESTRAINT SYSTEM (SRS)

Passenger Air Bag Module (Cont'd)

INSTALLATION

1. Install passenger air bag module in instrument panel.
 - a) Insert front edge of passenger air bag module first to ease installation.
 - Ensure harness is not caught between passenger air bag module and support bracket.
 - b) Install four mounting nuts.
 - c) Install two new special bolts using TAMPER RESISTANT TORX (Size T50).
2. Install instrument panel lower passenger side and glove box.

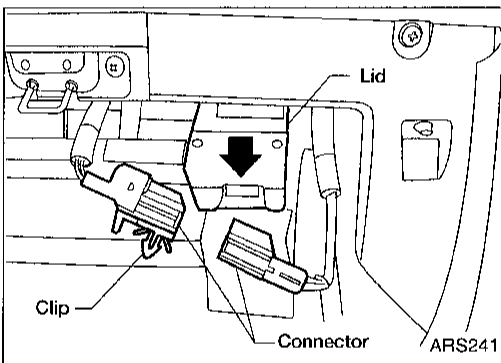
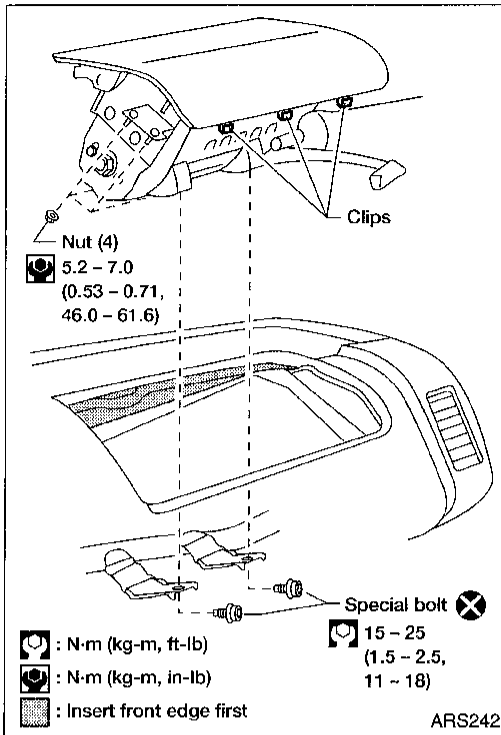

3. Connect passenger air bag module connector.
4. Attach passenger air bag module connector clip to lid.
5. Close lid and glove box.
6. Conduct Self-diagnosis to ensure SRS operates properly (Use CONSULT or warning lamp check.).

NOTE:

- After replacement, perform Self-diagnosis for SRS. Refer to "TROUBLE DIAGNOSES — Supplemental Restraint System (SRS)", "SRS Operation Check", RS-34.

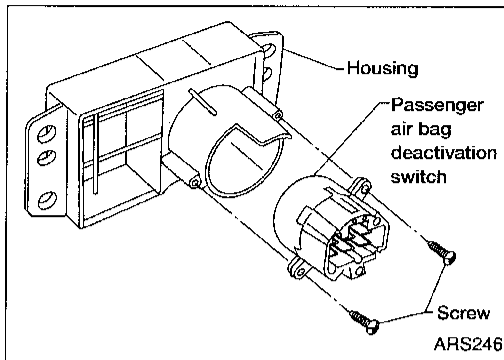

Passenger Air Bag Deactivation Switch

REMOVAL

- Before servicing SRS, turn the ignition switch OFF, disconnect both battery cables and wait for at least 3 minutes.
1. Detach instrument stay cover lower center from instrument panel. Refer to BT section ("INSTRUMENT PANEL").
 2. Disconnect passenger air bag deactivation switch harness connector and cigarette lighter harness connector.
 3. Remove instrument stay cover lower center.
 4. Remove two screws and remove passenger air bag deactivation switch.

INSTALLATION

CAUTION:

Passenger air bag deactivation switch is keyed for proper installation. Improper positioning of the switch will result in damage to the switch.

NOTE:

- Be sure that passenger air bag deactivation switch and lock cylinder are in the same position as during removal for proper engagement.
- To install, reverse removal procedure.
- After replacement, perform Self-diagnosis for SRS. Refer to "TROUBLE DIAGNOSES — Supplemental Restraint System (SRS)", "SRS Operation Check", RS-34.

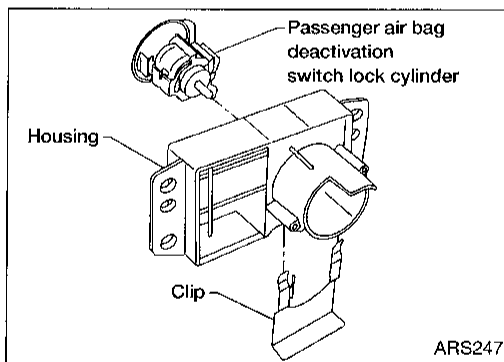

Passenger Air Bag Deactivation Switch Lock Cylinder

REMOVAL

- Before servicing SRS, turn the ignition switch OFF, disconnect both battery cables and wait for at least 3 minutes.
1. Detach instrument stay cover lower center from instrument panel. Refer to BT section ("INSTRUMENT PANEL").
 2. Disconnect passenger air bag deactivation switch harness connector and cigarette lighter harness connector.
 3. Remove instrument stay cover lower center.
 4. Remove four screws and housing from instrument stay cover lower center.
 5. Remove clip from bottom of housing.
 6. Remove passenger air bag deactivation switch lock cylinder from front of housing.

INSTALLATION

NOTE:

- Be sure that passenger air bag deactivation switch and lock cylinder are in the same position as during removal for proper engagement.
- To install, reverse removal procedure.
- After replacement, perform Self-diagnosis for SRS. Refer to "TROUBLE DIAGNOSES — Supplemental Restraint System (SRS)", "SRS Operation Check", RS-34.

GI
MA
EM
LC
EC
FE
CL
MT
AT
TF
PD
FA
RA
BR
ST
RS
BT
HA
EL
IDX

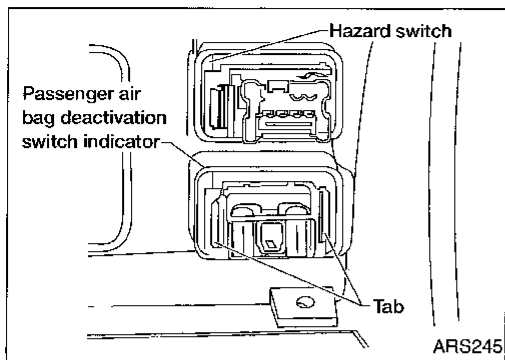

Passenger Air Bag Deactivation Switch Indicator

REMOVAL

- Before servicing SRS, turn the ignition switch OFF, disconnect both battery cables and wait for at least 3 minutes.
1. Remove meter cover. Refer to BT section ("INSTRUMENT PANEL").
 2. Release passenger air bag deactivation switch indicator tabs from back side of meter cover.
 3. Remove passenger air bag deactivation switch indicator from front side of meter cover.

INSTALLATION

NOTE:

- To install, reverse removal procedure.
- After replacement, perform Self-diagnosis for SRS. Refer to "TROUBLE DIAGNOSES — Supplemental Restraint System (SRS)", "SRS Operation Check", RS-34.

Disposal of Air Bag Module

- Before disposing of air bag module, or vehicles equipped with such a system, deploy the system. If such a system has already been deployed due to an accident, dispose of as indicated in "DISPOSING OF AIR BAG MODULE" (RS-26).
- When deploying the air bag module, always use the Special Service Tool; Deployment tool KV99106400 (Kent-Moore No. J38381).
- When deploying the air bag module, stand at least 5 m (16 ft) away from the deployment component.
- When deploying air bag module, a fairly loud noise is made, followed by smoke being released. The smoke is not poisonous, however, be careful not to inhale smoke since it irritates the throat and can cause choking.
- Always activate one air bag module at a time.
- Due to heat, leave air bag module unattended for more than 30 minutes after deployment.
- Be sure to wear gloves when handling a deployed air bag module.
- Never apply water to a deployed air bag module.
- Wash your hands clean after finishing work.
- Place the vehicle outdoors with an open space of at least 6 m (20 ft) on all sides when deploying air bag module while mounted in vehicle.
- Use a voltmeter to make sure the vehicle battery is fully charged.
- Do not dispose of the air bag module un-deployed.

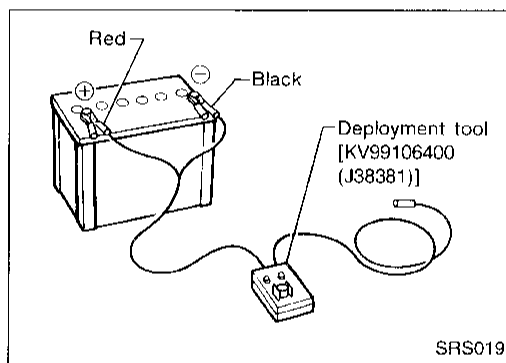

CHECKING DEPLOYMENT TOOL

Connecting to battery

- Place vehicle outdoors with at least 6 m (20 ft) of open space on all sides.
- Use a voltmeter to make sure the vehicle battery is fully charged.

CAUTION:

The battery must show voltage of 9.6V or more.

Remove the battery from the vehicle and place it on dry wood blocks approximately 5 m (16 ft) away from the vehicle.

- Wait 3 minutes after the vehicle battery is disconnected before proceeding.
- Connect red clip of deployment tool to battery positive terminal and black clip to negative terminal.

CAUTION:

Make sure the polarity is correct. The right side lamp in the tool, marked "deployment tool power", should glow with a green light. If the right side lamp glows red, reverse the connections to the battery.

GI

MA

EM

LC

EC

FE

CL

MT

AT

TF

PD

FA

RA

BR

ST

RS

BT

HA

EL

IDX

SUPPLEMENTAL RESTRAINT SYSTEM (SRS)

Disposal of Air Bag Module (Cont'd)

Deployment tool check

Press the deployment tool switch to the ON position. The left side lamp in the tool, marked "air bag connector voltage" should illuminate. If it does not illuminate, replace the tool.

Air bag deployment tool lamp illumination chart (Battery connected)

Switch operation	Left side lamp, green* "AIR BAG CONNECTOR VOLTAGE"	Right side lamp, green* "DEPLOYMENT TOOL POWER"
OFF	OFF	ON
ON	ON	ON

*: If this lamp glows red, the tool is connected to the battery incorrectly. Reverse the connections and make sure the lamp glows green.

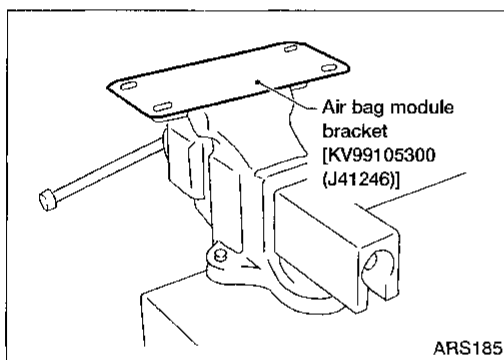
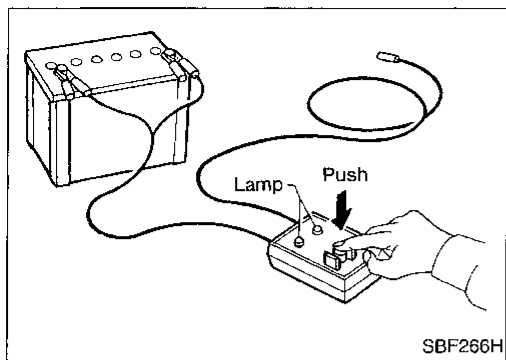

DEPLOYMENT PROCEDURES FOR AIR BAG MODULE (OUTSIDE OF VEHICLE)

Unless the vehicle is being scrapped, deploying the air bag in the vehicle is not recommended. This may cause damage to the vehicle interior.

Anchor air bag module bracket [KV99105300 (J41246)] in a vise secured to a firm foundation during deployment.

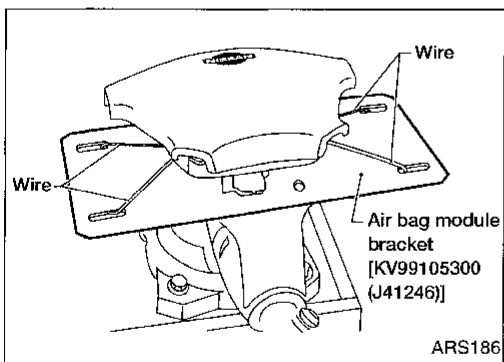

Deployment of driver air bag module (outside of vehicle)

- Using wire, firmly secure driver air bag module to air bag module bracket [SST: KV99105300 (J41246)] at two places.

CAUTION:

Use wire of at least 1 mm (0.04 in) diameter.

- Firmly secure air bag module bracket [SST: KV99105300 (J41246)] with driver air bag module attached, in a vise.

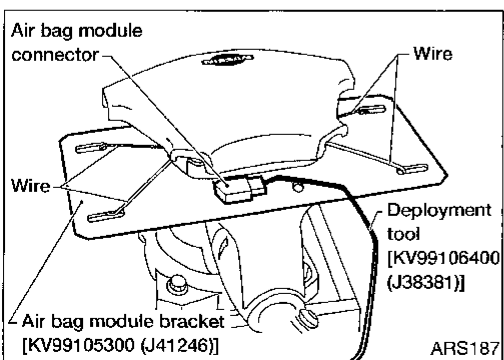

- Connect deployment tool [SST: KV99106400 (J38381)] to driver air bag module connector.

SUPPLEMENTAL RESTRAINT SYSTEM (SRS)

Disposal of Air Bag Module (Cont'd)

4. Connect red clip of deployment tool to battery positive terminal and black clip to negative terminal.
5. The lamp on the right side of the tool, marked "deployment tool power", should glow green, not red.
6. Press the button on the deployment tool. The left side lamp on the tool, marked "air bag connector voltage", will illuminate and the air bag module will deploy.

CAUTION:

When deploying the air bag module, stand at least 5 m (16 ft) away from the air bag module.

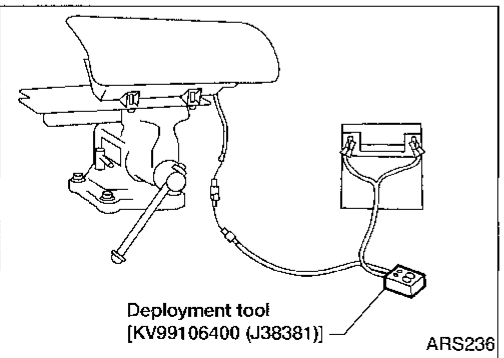
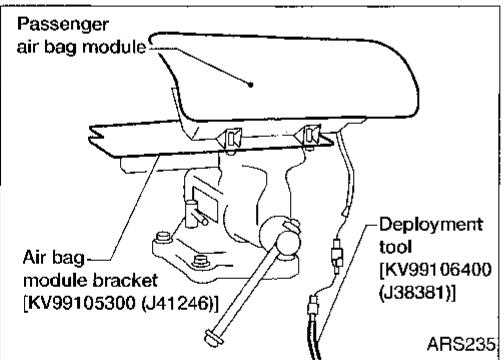
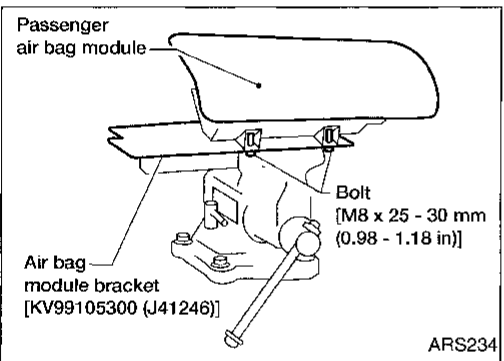
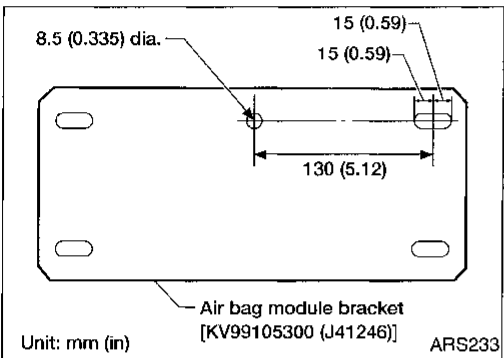
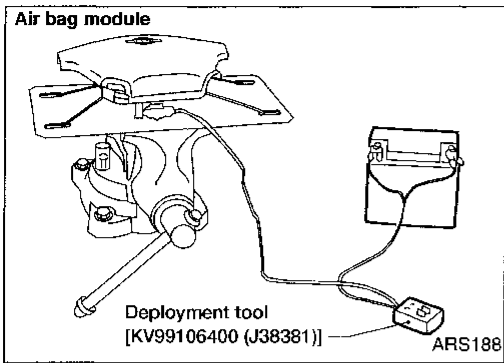

Deployment of passenger air bag module (outside of vehicle)

1. Make an 8.5 mm (0.335 in) diameter hole in air bag module bracket [SST: KV99105300 (J41246)] at the position shown in figure at left.

2. Firmly secure air bag module bracket [SST: KV99105300 (J41246)] in a vise.
3. Match the two holes in air bag module bracket (held in vise) and passenger air bag module and fix them with two bolts [M8 x 25 - 30 mm (0.98 - 1.18 in)].

CAUTION:

If a gap exists between passenger air bag module and air bag module bracket, use a piece of wood inserted in the gap to stabilize the air bag module.

4. Connect deployment tool adapter [SST: KV991065S0 (J38381-30)] to deployment tool [SST: KV99106400 (J38381)] connector and air bag module connector.

5. Connect red clip of deployment tool to battery positive terminal and black clip to negative terminal.
6. The lamp on the right side of the tool, marked "deployment tool power", should glow green, not red.
7. Press the button on the deployment tool. The left side lamp on the tool, marked "air bag connector voltage", will illuminate and the air bag module will deploy.

CAUTION:

When deploying the air bag module, stand at least 5 m (16 ft) away from the air bag module.

GI
MA
EM
LC
EC
FE
CL
MT
AT
TF
PD
FA
RA
BR
ST
RS
BT
HA
EL
IDX

SUPPLEMENTAL RESTRAINT SYSTEM (SRS)

Disposal of Air Bag Module (Cont'd)

DEPLOYMENT OF AIR BAG MODULE WHILE MOUNTED IN VEHICLE

When disposing of vehicles, deploy air bag module while it is mounted in vehicle.

CAUTION:

When deploying air bag module, ensure vehicle is empty.

1. Turn ignition switch OFF, disconnect both battery cables and wait at least 3 minutes.
2. Disconnect air bag module connector.
3. Connect deployment tool [SST:KV99106400 (J38381)] connector to air bag module.

For passenger air bag module, use adapter [SST:KV99106400 (J38381-30)] to attach module to deployment tool connector.

4. Connect red clip of deployment tool to battery positive terminal and black clip to negative terminal.
5. The lamp on the right side of the tool, marked "deployment tool power", should glow green, not red.
6. Press the button on the deployment tool. The left side lamp on the tool, marked "air bag connector voltage", will illuminate. Then the air bag module will deploy.

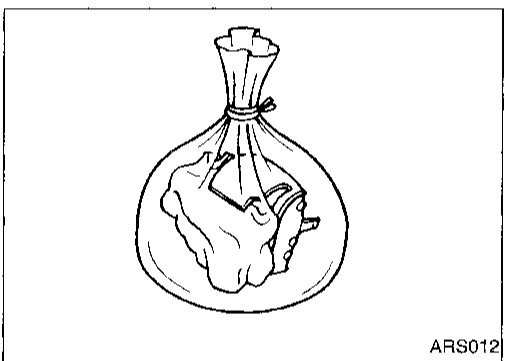
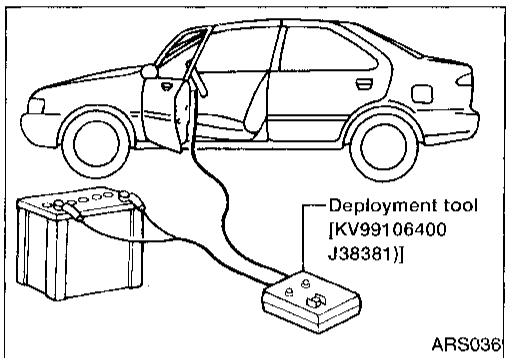
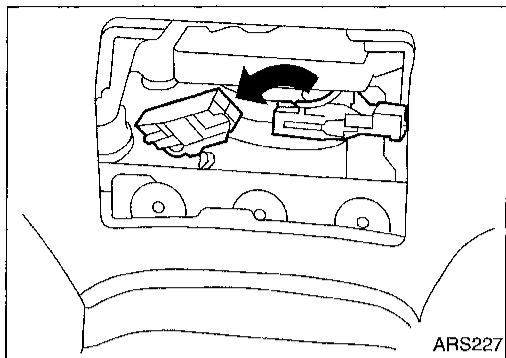

DISPOSING OF AIR BAG MODULE

Deployed air bag module is very hot. Before disposing of air bag module, wait at least 30 minutes. Seal them in a plastic bag before disposal.

CAUTION:

- Never apply water to a deployed air bag module.
- Be sure to wear gloves when handling a deployed air bag module.
- No poisonous gas is produced upon air bag module deployment. However, be careful not to inhale gas since it irritates throat and can cause choking.
- Do not attempt to disassemble air bag module.
- Air bag module cannot be reused.
- Wash your hands clean after finishing work.

Trouble Diagnosis Introduction

CAUTION:

- Do not use electrical test equipment on any circuit related to the SRS unless instructed to in this Service Manual. SRS wiring harnesses are covered with yellow insulation either just before the harness connectors or on the complete harness, for easy identification.
- Do not attempt to repair, splice or modify the SRS wiring harness. If the harness is damaged, replace it with a new one.
- Keep ground portion clean.

DIAGNOSIS FUNCTION

The SRS Self-diagnosis results can be read by using the “AIR BAG” warning lamp and/or CONSULT. The reading of these results is accomplished using one of two modes — “User mode” and “Diagnosis mode”. The User mode is exclusively prepared for the customer (driver). This mode warns the driver of a system malfunction through the operation of the “AIR BAG” warning lamp.

The Diagnosis mode allows the technician to locate and inspect the malfunctioning part.

The mode applications for the “AIR BAG” warning lamp and CONSULT are as follows:

	User mode	Diagnosis mode	Display type
“AIR BAG” warning lamp	X	X	ON-OFF operation
CONSULT	—	X	Monitoring

DIAGNOSIS MODE FOR CONSULT

- “SELF-DIAG [CURRENT]”
A current Self-diagnosis result (also indicated by the number of warning lamp flashes in the Diagnosis mode) is displayed on the CONSULT screen in real time. This refers to a malfunctioning part requiring repairs.
- “SELF-DIAG [PAST]”
Diagnosis results previously stored in the memory are displayed on the CONSULT screen. The stored results are not cleared until memory erasing is executed.
- “TROUBLE DIAG RECORD”
With “TROUBLE DIAG RECORD”, diagnosis results previously erased by a reset operation can be displayed on the CONSULT screen.

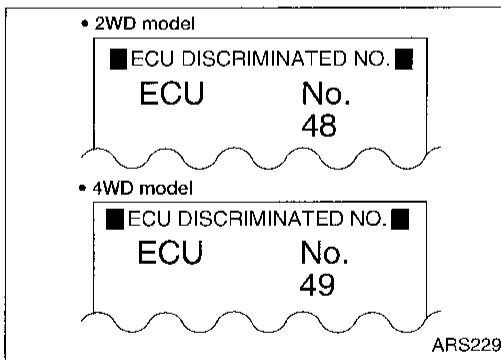

- ECU DISCRIMINATED NO.
The air bag diagnosis sensor unit for each vehicle model is assigned with its own, individual classification number. This number will be displayed on the CONSULT screen, as shown at left. When replacing the diagnosis sensor unit, refer to the part number for the compatibility. After installation, replacement with a correct unit can be checked by confirming this classification number on the CONSULT screen.
For NISSAN model D22, the air bag diagnosis sensor unit classification numbers assigned are 48 (for 2WD models) and 49 (for 4WD models).

GI
 MA
 EM
 LC
 EC
 FE
 CL
 MT
 AT
 TF
 PD
 FA
 RA
 BR
 ST
 RS
 BT
 HA
 EL
 IDX

Trouble Diagnosis Introduction (Cont'd)

HOW TO CHANGE SELF DIAGNOSIS MODE

With CONSULT

From User mode to Diagnosis mode

Touch "AIRBAG" on the "SELECT SYSTEM" screen. User mode automatically changes to Diagnosis mode.

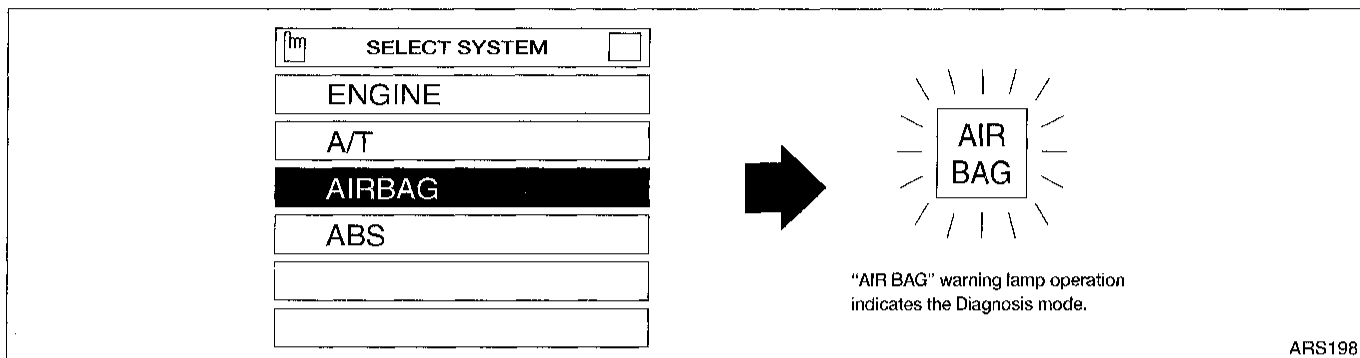

From Diagnosis mode to User mode

Touch "BACK" key of CONSULT until "SELECT SYSTEM" appears, Diagnosis mode automatically changes to User mode.

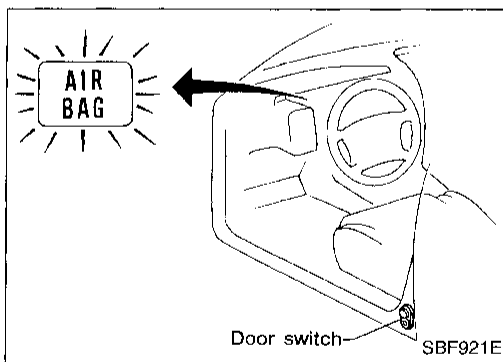
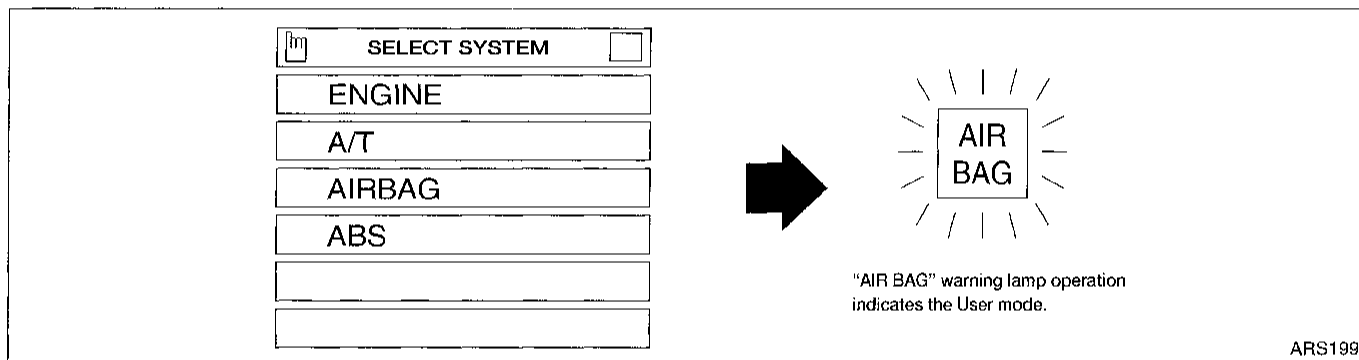

Without CONSULT

From User mode to Diagnosis mode

Diagnosis mode can be activated only when a malfunction is detected, by pressing the door switch LH at least 5 times within 7 seconds after turning the ignition switch ON. SRS will not enter Diagnosis mode if no malfunction is detected.

From Diagnosis mode to User mode

- To return to User mode while a malfunction is being detected, turn ignition switch OFF, then back ON and press the door switch LH at least 5 times within 7 seconds.
- After a malfunction is repaired, turn ignition switch OFF for at least one second, then back ON. Diagnosis mode returns to User mode.

HOW TO ERASE SELF DIAGNOSIS RESULTS

With CONSULT

SELF-DIAG [CURRENT]

A current Self-diagnosis result is displayed on the CONSULT screen in real time. After the malfunction is repaired completely, no malfunction is detected on "SELF-DIAG [CURRENT]".

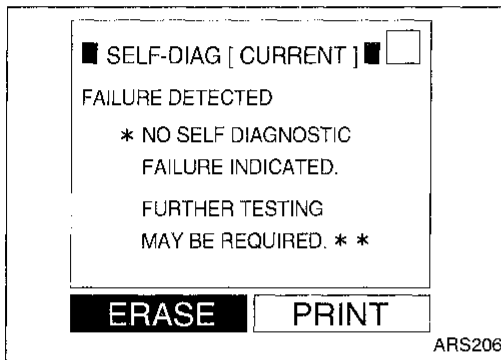

SELF-DIAG [PAST]

Return to the "SELF-DIAG [CURRENT]" CONSULT screen by pushing "BACK" key of CONSULT and select "SELF-DIAG [CURRENT]" in "SELECT DIAG MODE". Touch "ERASE" in "SELF-DIAG [CURRENT]" mode.

NOTE:

If the memory of the malfunction in "SELF-DIAG [PAST]" is not erased, the User mode shows the system malfunction by the operation of the warning lamp even if the malfunction is repaired completely.

TROUBLE DIAG RECORD

The memory of "TROUBLE DIAG RECORD" cannot be erased.

Without CONSULT

After a malfunction is repaired, turn ignition switch OFF for at least one second, then back ON. Diagnosis mode returns to User mode. At that time, the problem code is cleared.

GI

MA

EM

LG

EC

FE

CL

MT

AT

TF

PD

FA

RA

BR

ST

RS

BT

HA

EL

IDX

How to Perform Trouble Diagnoses for Quick and Accurate Repair

A good understanding of the malfunction conditions can make troubleshooting faster and more accurate. In general, each customer feels differently about a problem. It is important to fully understand the symptoms or conditions of a customer complaint.

INFORMATION FROM CUSTOMER

- WHAT Vehicle model
- WHEN Date, Frequencies
- WHERE Road conditions
- HOW Operating conditions, Symptoms

PRELIMINARY CHECK

Check that the following parts are in good order.

- Battery [Refer to EL section (“BATTERY”).]
- Fuse [Refer to EL section (“Fuse”, “POWER SUPPLY ROUTING”).]
- System component-to-harness connections

WORK FLOW

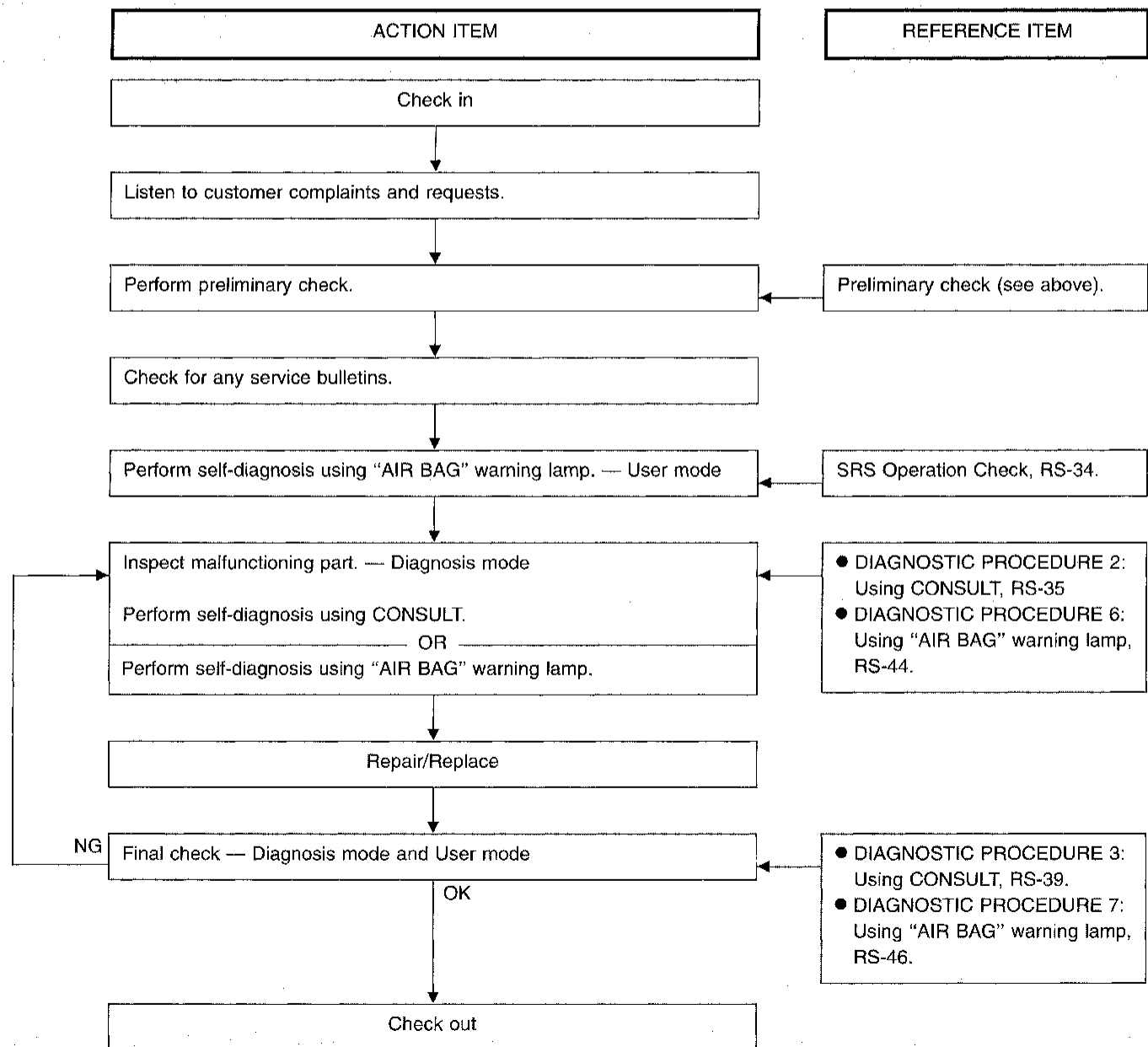

Schematic

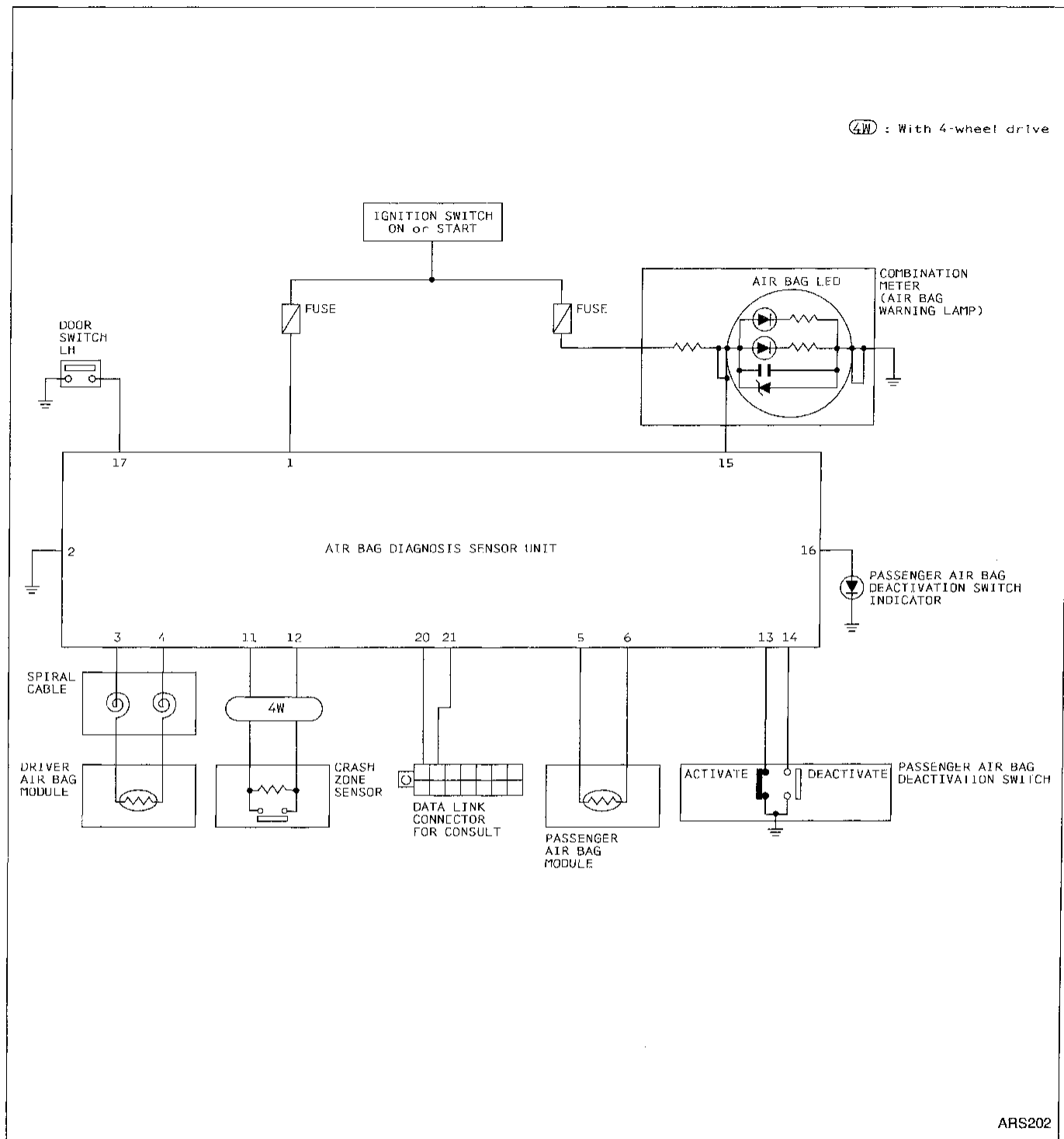

ARS202

GI
MA
EM
LC
EC
FE
CL
MT
AT
TF
PD
FA
RA
BR
ST
RS
BT
HA
EL
IDX

Wiring Diagram -SRS-

RS-SRS-01

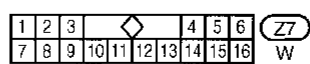
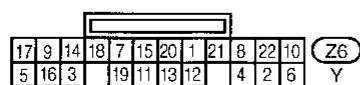
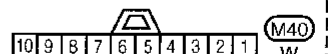
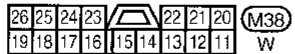
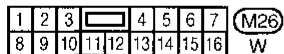
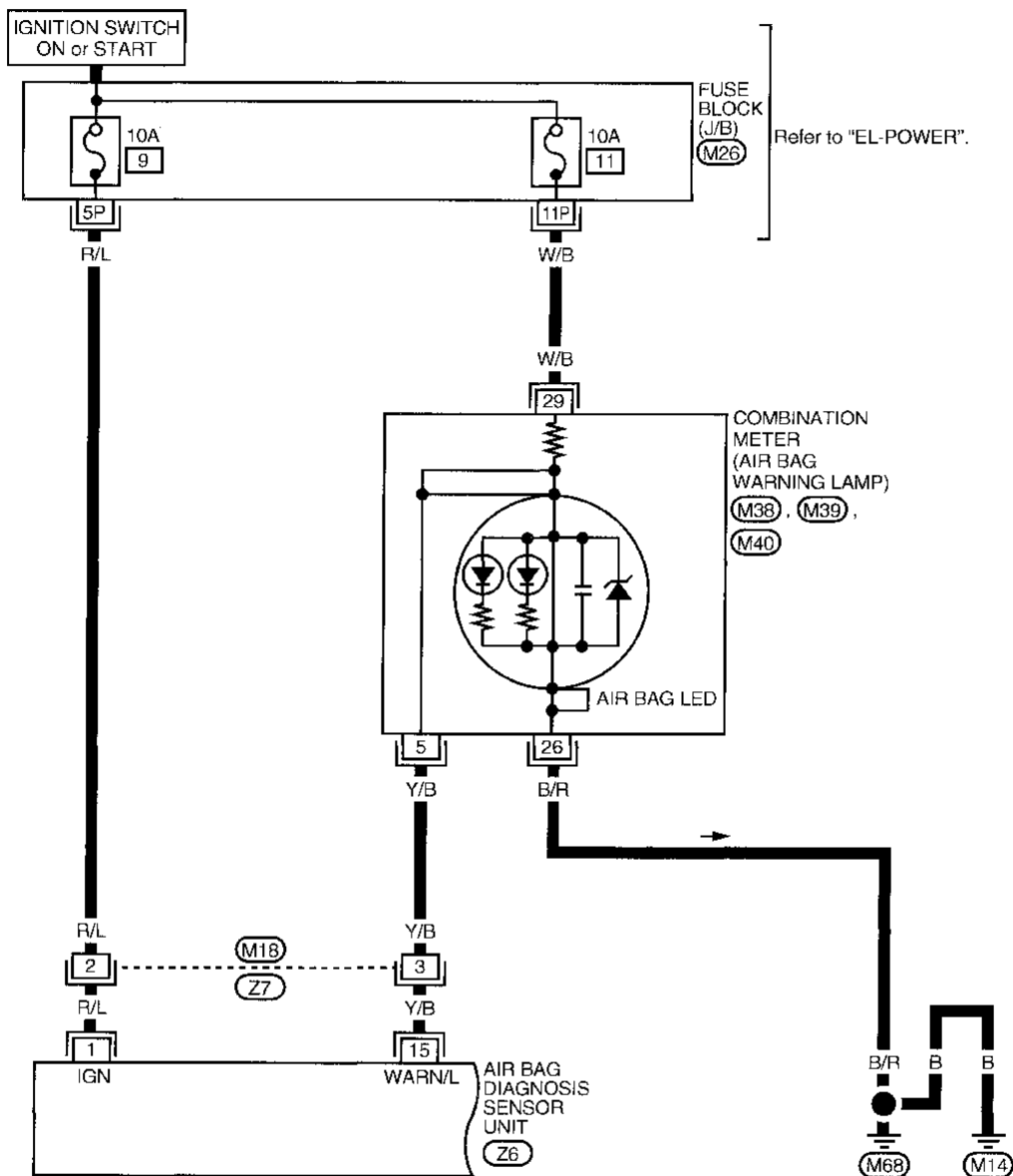

TROUBLE DIAGNOSES — Supplemental Restraint System (SRS)

Wiring Diagram -SRS- (Cont'd)

RS-SRS-02

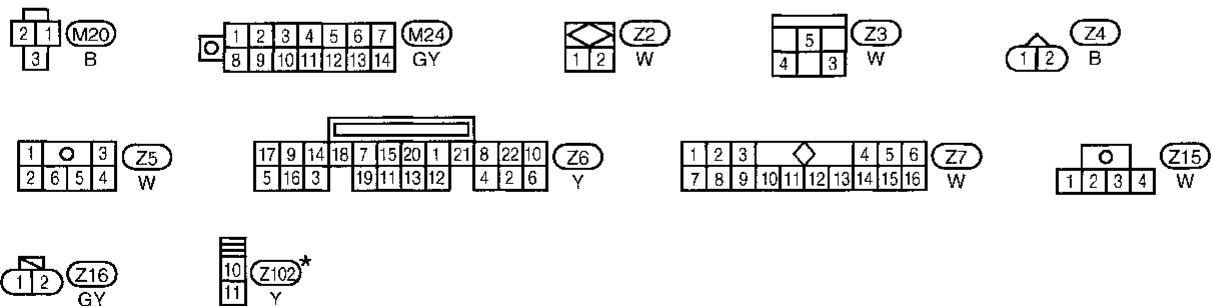
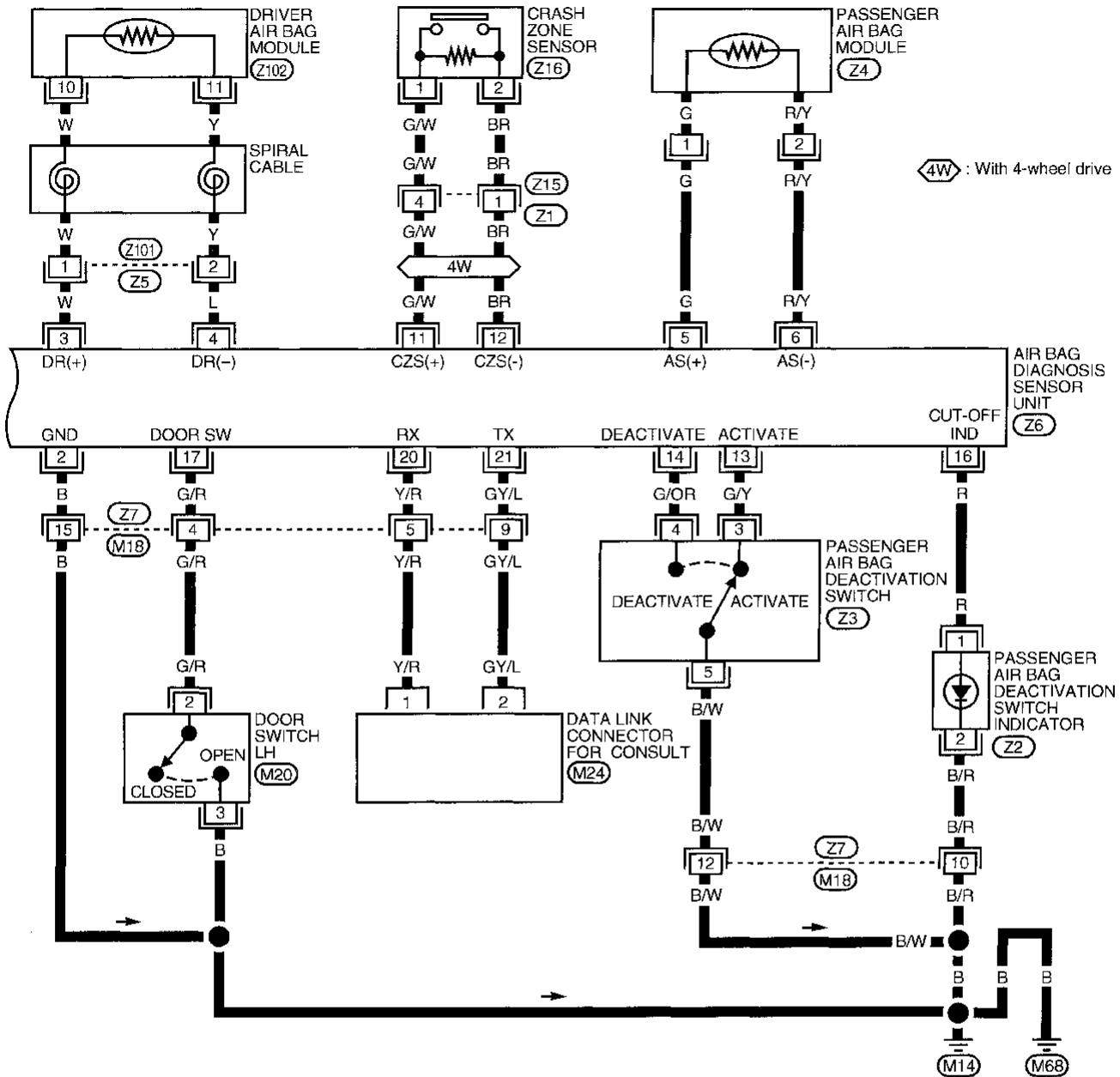

*: This connector is not shown in "HARNESS LAYOUT" of EL section.

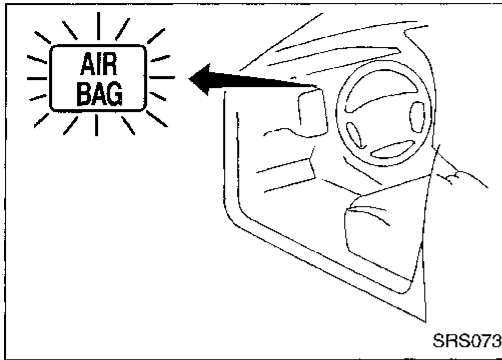

SRS Operation Check

DIAGNOSTIC PROCEDURE 1

Checking SRS operation by using "AIR BAG" warning lamp — User mode

1. After turning ignition switch from OFF to ON, "AIR BAG" warning lamp operates.
2. Compare "AIR BAG" warning lamp operation to the chart below.

"AIR BAG" warning lamp operation — User mode —	SRS condition	Reference item
<p style="text-align: right; margin-top: 10px;">MRS095A</p>	<p>No malfunction is detected. No further action is necessary.</p>	<p>—</p>
<p style="text-align: right; margin-top: 10px;">MRS096A</p>	<p>The system has problem and needs to be repaired as indicated.</p>	<p>Go to DIAGNOSTIC PROCEDURE 2, or 6, RS-35 or 44.</p>
<p style="text-align: right; margin-top: 10px;">MRS097A</p>	<p>Air bag is deployed.</p> <p>Air bag fuse for air bag diagnosis sensor unit or circuit is malfunctioning and needs to be repaired.</p>	<p>Go to COLLISION DIAGNOSIS, RS-51.</p> <p>Go to DIAGNOSTIC PROCEDURE 9, RS-48.</p>
<p style="text-align: right; margin-top: 10px;">MRS098A</p>	<p>One of the following has occurred and needs to be repaired.</p> <ul style="list-style-type: none"> ● Meter fuse is open. ● "AIR BAG" warning lamp circuit is shorted or open. ● Air bag diagnosis sensor unit is malfunctioning. 	<p>Go to DIAGNOSTIC PROCEDURE 10, RS-49.</p>

NOTE:

If "AIR BAG" warning lamp operates differently from the operations shown above, refer to "AIR BAG" warning lamp operation — Diagnosis mode —, DIAGNOSTIC PROCEDURE 6, step 4, RS-44. Then repair as necessary.

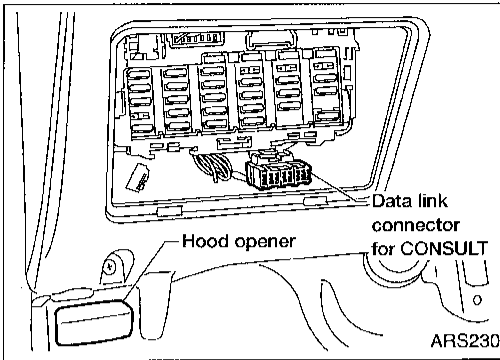

📱 Trouble Diagnoses with CONSULT

DIAGNOSTIC PROCEDURE 2

Inspecting SRS malfunctioning parts by using CONSULT — Diagnosis mode

1. Turn ignition switch OFF.
2. Connect CONSULT to Data link connector.

3. Turn ignition switch ON.
4. Touch "START".

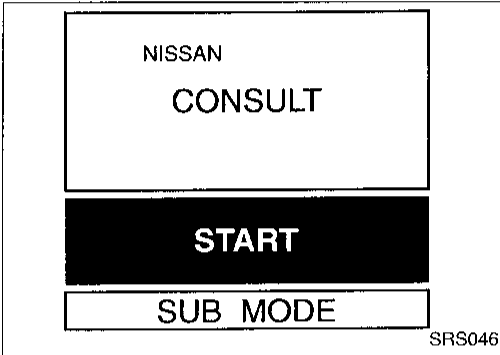

5. Touch "AIRBAG".

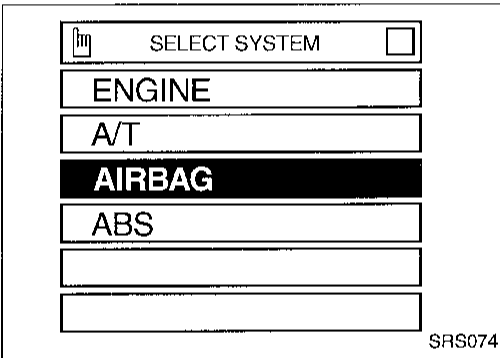

6. Touch "SELF-DIAG [CURRENT]".

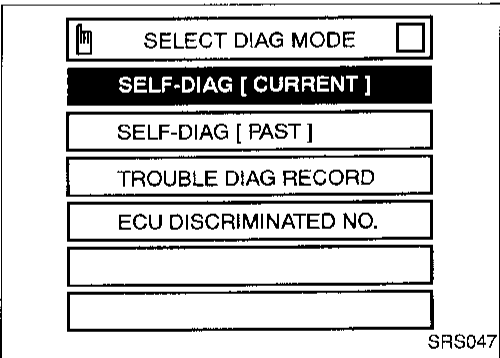

7. Diagnostic codes are displayed on "SELF-DIAG [CURRENT]".

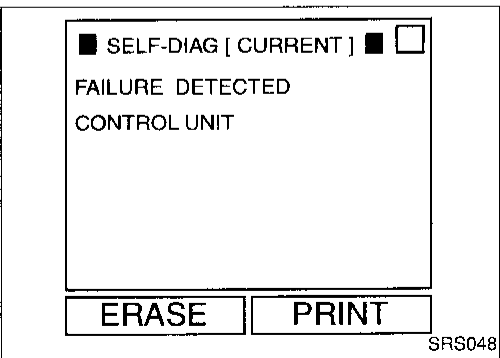

GI

MA

EM

LC

EC

FE

CL

MT

AT

TF

PD

FA

RA

BR

ST

RS

BT

HA

EL

IDX

Trouble Diagnoses with CONSULT (Cont'd)

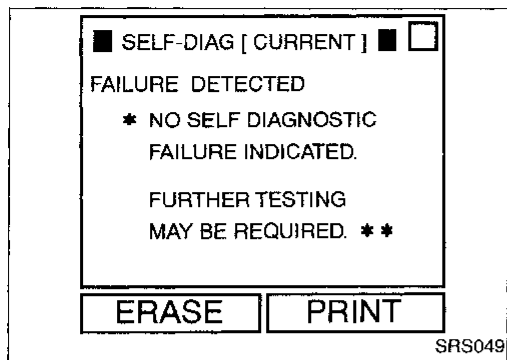

- If no self-diagnostic failure is detected on “SELF-DIAG [CURRENT]” but malfunction is indicated by the “AIR BAG” warning lamp in User mode, go to **DIAGNOSTIC PROCEDURE 4, RS-40** for diagnosing the following cases:
 - Self-diagnostic failure (previously stored in the memory) might not be erased after repair.
 - The SRS system is malfunctioning intermittently.
8. Touch “PRINT”.
 9. Compare diagnostic codes to the CONSULT DIAGNOSTIC CODE CHART, RS-37.
 10. Touch “BACK” key of CONSULT until “SELECT SYSTEM” appears in order to return to User mode from Diagnosis mode, then turn off CONSULT.
 11. Turn ignition switch OFF, then disconnect CONSULT and both battery cables.
 12. Repair the system as outlined by the Repair order in CONSULT DIAGNOSTIC CODE CHART, that corresponds to the problem code. For replacement procedure of component parts, refer to RS-14.
 13. After repairing the system, connect battery cables and go to **DIAGNOSTIC PROCEDURE 3, RS-39** for final checking.

TROUBLE DIAGNOSES — Supplemental Restraint System (SRS)

📱 Trouble Diagnoses with CONSULT (Cont'd)

CONSULT DIAGNOSTIC CODE CHART (“SELF-DIAG [CURRENT]”)

Diagnostic item	Explanation/Possible causes	Repair order *Recheck SRS using CONSULT at each replacement
NO SELF DIAGNOSTIC FAILURE INDICATED	When malfunction is indicated by the “AIR BAG” warning lamp in User mode. <ul style="list-style-type: none"> ● Self-diagnostic failure “SELF-DIAG [PAST]” (previously stored in the memory) might not be erased after repair. ● Intermittent problem has been detected in the past. 	<ul style="list-style-type: none"> ● Go to DIAGNOSTIC PROCEDURE 4, RS-40.
	<ul style="list-style-type: none"> ● No malfunction is detected. 	<ul style="list-style-type: none"> ● Go to DIAGNOSTIC PROCEDURE 3, RS-39.
AIRBAG MODULE [OPEN]	<ul style="list-style-type: none"> ● Air bag module circuit is open (including the spiral cable). 	<ol style="list-style-type: none"> 1. Visually check wiring harness connections. 2. Replace air bag harness if it has visible damage. 3. Replace spiral cable. 4. Replace air bag module. (Before disposing of it, it must be deployed.) 5. Replace air bag diagnosis sensor unit. 6. Replace air bag harness.
AIRBAG MODULE [VB-SHORT]	<ul style="list-style-type: none"> ● Air bag module circuit is shorted to some power supply circuit (including the spiral cable). 	
AIRBAG MODULE [GND-SHORT]	<ul style="list-style-type: none"> ● Air bag module circuit is shorted to ground (including the spiral cable). 	
AIRBAG MODULE [SHORT]	<ul style="list-style-type: none"> ● Air bag module circuits are shorted to each other. 	
ASSIST A/B MODULE [VB-SHORT]	<ul style="list-style-type: none"> ● Passenger air bag module circuit is shorted to some power supply circuit. 	<ol style="list-style-type: none"> 1. Visually check wiring harness connection. 2. Replace air bag harness if it has visible damage. 3. Replace passenger air bag module. (Before disposal of it, it must be deployed.) 4. Replace air bag diagnosis sensor unit. 5. Replace air bag harness.
ASSIST A/B MODULE [OPEN]	<ul style="list-style-type: none"> ● Passenger air bag module circuit is open. 	
ASSIST A/B MODULE [GND-SHORT]	<ul style="list-style-type: none"> ● Passenger air bag module circuit is shorted to ground. 	
ASSIST A/B MODULE [SHORT]	<ul style="list-style-type: none"> ● Passenger air bag module circuits are shorted to each other. 	
CRASH ZONE SEN-CTR [OPEN/UPR-VB-SHORT] (4WD models)	<ul style="list-style-type: none"> ● Crash zone sensor circuit is open, or ● Crash zone sensor circuit is shorted to some power supply circuit. 	<ol style="list-style-type: none"> 1. Visually check wiring harness connections. 2. Replace air bag harness if it has visible damage. 3. Replace crash zone sensor. 4. Replace air bag diagnosis sensor unit. 5. Replace air bag harness for crash zone sensor.
CRASH ZONE SEN-CTR [SHORT/UPR-GND-SHORT] (4WD models)	<ul style="list-style-type: none"> ● Both crash zone sensor circuits are shorted, or ● Crash zone sensor circuit is shorted to ground. 	
CONTROL UNIT	<ul style="list-style-type: none"> ● Low battery voltage (Less than 9V). 	<ul style="list-style-type: none"> ● Go to DIAGNOSTIC PROCEDURE 3 (RS-39) after charging battery.
	<ul style="list-style-type: none"> ● Air bag diagnosis sensor unit is malfunctioning. 	<ol style="list-style-type: none"> 1. Visually check wiring harness connections. 2. Replace air bag harness if it has visible damage. 3. Replace air bag diagnosis sensor unit. 4. Replace air bag harness.

GI

MA

EM

LC

EC

FE

CL

MT

AT

TF

PD

FA

RA

BR

ST

RS

BT

HA

EL

IDX

TROUBLE DIAGNOSES — Supplemental Restraint System (SRS)



Trouble Diagnoses with CONSULT (Cont'd)

Diagnostic item	Explanation/Possible causes	Repair order *Recheck SRS using CONSULT at each replacement
PASS A/B DEACT SW	● Activate terminal is open.	<ol style="list-style-type: none"> 1. Visually check wiring harness connections. 2. Replace air bag harness if it has visible damage. 3. Replace passenger air bag deactivation switch. (The key cylinder of passenger air bag deactivation switch does not have to be replaced.) 4. Replace air bag diagnosis sensor unit. 5. Replace air bag harness.
	● Activate terminal is shorted to ground.	
	● Deactivate terminal is open.	
	● Deactivate terminal is shorted to ground.	
	● Activate terminal and deactivate terminal are shorted to each other.	
PASS A/B DEACT SW INDICATOR	● Passenger air bag deactivation switch indicator circuit is open.	<ol style="list-style-type: none"> 1. Visually check wiring harness connections. 2. Replace air bag harness if it has visible damage. 3. Replace passenger air bag deactivation switch indicator. 4. Replace air bag diagnosis sensor unit. 5. Replace air bag harness.
	● Passenger air bag deactivation switch indicator circuit is shorted to some power supply circuit.	
	● Passenger air bag deactivation switch indicator circuit is shorted to ground.	
INDEFINITE FAILURES [AIR BAGS]	● Passenger air bag deactivation switch status is not identified.	<ol style="list-style-type: none"> 1. Visually check wiring harness connections. 2. Replace air bag harness if it has visible damage. 3. Replace passenger air bag deactivation switch. 4. Replace air bag diagnosis sensor unit. 5. Replace air bag harness.

*Follow the procedures in numerical order when repairing malfunctioning parts. Confirm whether malfunction is eliminated using the "AIR BAG" warning lamp (In User mode) or CONSULT each time repair is finished. If malfunction is still observed, proceed to the next step. When malfunction is eliminated, further repair work is not required.

📱 Trouble Diagnoses with CONSULT (Cont'd)

DIAGNOSTIC PROCEDURE 3

Final checking after repairing SRS by using CONSULT — Diagnosis mode

1. Check that both battery cables are connected.
2. Connect CONSULT to Data link connector.
3. Turn ignition switch from OFF to ON.

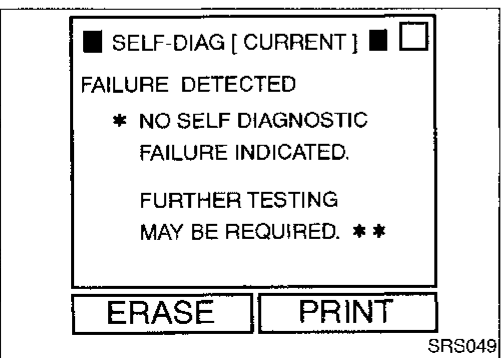
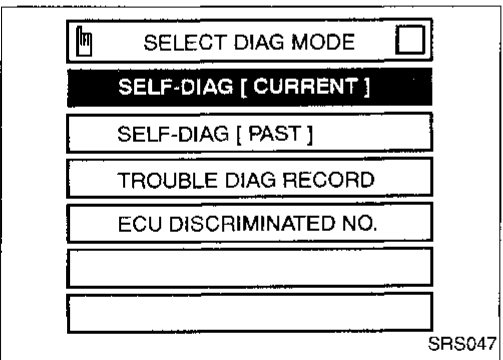
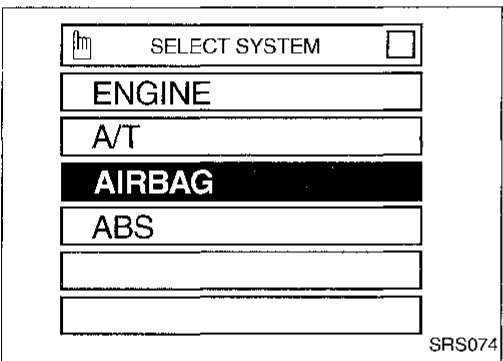
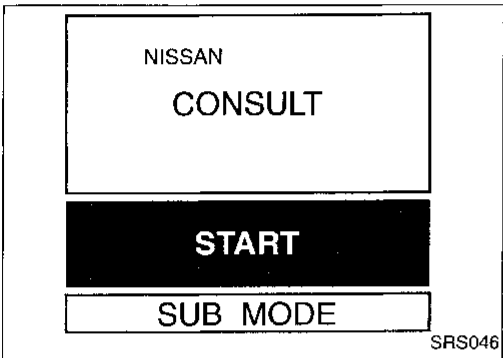
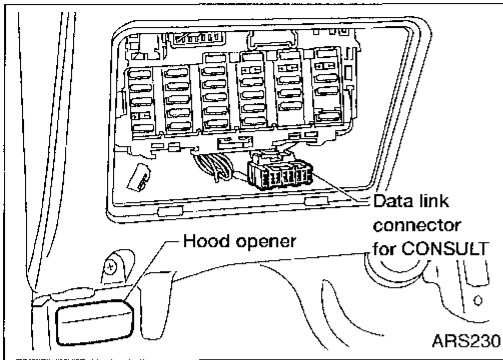

4. Touch "START".

5. Touch "AIRBAG".

6. Touch "SELF-DIAG [CURRENT]".

7. If no malfunction is detected on "SELF-DIAG [CURRENT]", repair of SRS is completed.
 - If any problem code was displayed on "SELF-DIAG [CURRENT]", the malfunctioning part is not repaired completely or another malfunctioning part is detected. Go to DIAGNOSTIC PROCEDURE 2, RS-35 and repair malfunctioning part completely.

GI
MA
EM
LC
EC
FE
CL
MT
AT
TF
PD
FA
RA
BR
ST
RS
BT
HA
EL
IDX

📱 Trouble Diagnoses with CONSULT (Cont'd)

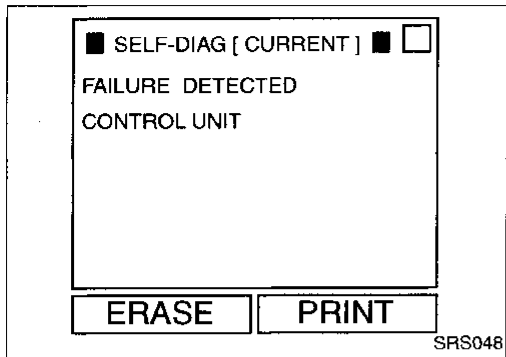

8. Touch "ERASE".

NOTE:

Touch "ERASE" to clear the memory of the malfunction ("SELF-DIAG [PAST]").

If the memory of the malfunction in "SELF-DIAG [PAST]" is not erased, the User mode shows the system malfunction by the operation of the warning lamp even if the malfunction is repaired completely.

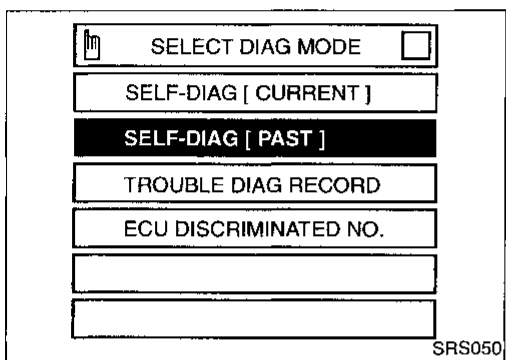

9. Touch "BACK" key of CONSULT to "SELECT DIAG MODE" screen.

Touch "SELF-DIAG [PAST]".

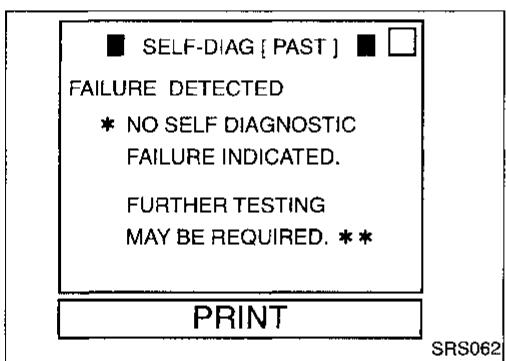

10. Check that no self-diagnostic failure is detected on "SELF-DIAG [PAST]".

11. Touch "BACK" key of CONSULT until "SELECT SYSTEM" appears in order to return to User mode from Diagnosis mode, turn off CONSULT, then disconnect CONSULT.

12. Turn ignition switch OFF.

13. Go to SRS Operation Check, RS-34 to check SRS operation by using "AIR BAG" warning lamp with User mode.

DIAGNOSTIC PROCEDURE 4 (Continued from DIAGNOSTIC PROCEDURE 2)

Inspecting SRS malfunctioning record

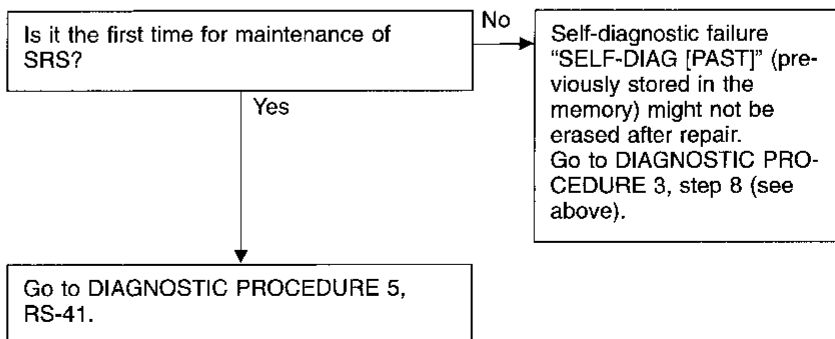

📱 Trouble Diagnoses with CONSULT (Cont'd)

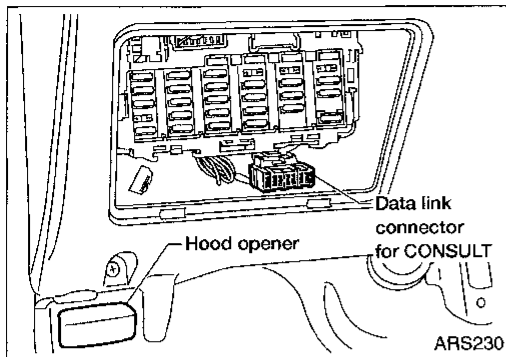

DIAGNOSTIC PROCEDURE 5

Inspecting SRS intermittent problem by using CONSULT — Diagnosis mode

1. Turn ignition switch OFF.
2. Connect CONSULT to Data link connector.

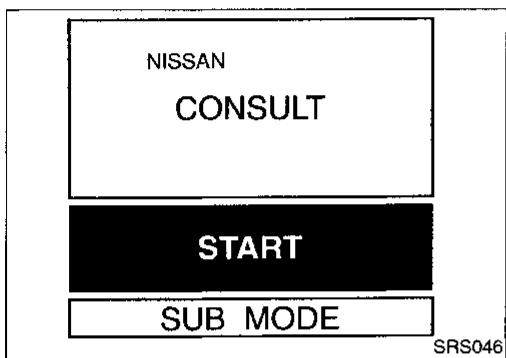

3. Turn ignition switch ON.
4. Touch "START".

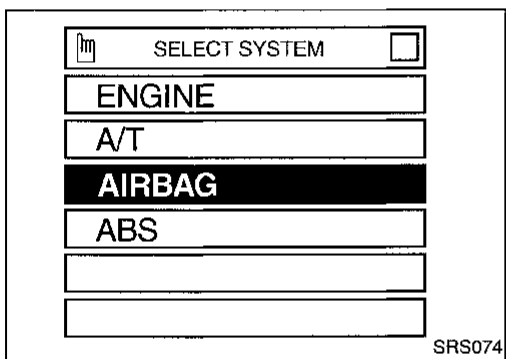

5. Touch "AIRBAG".

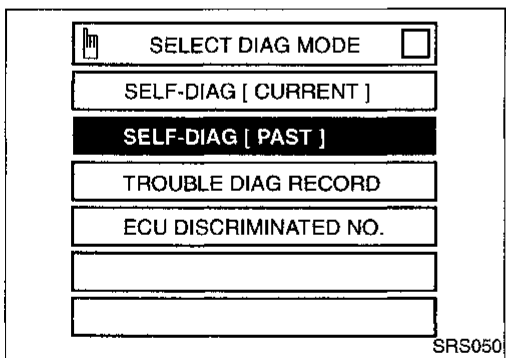

6. Touch "SELF-DIAG [PAST]".

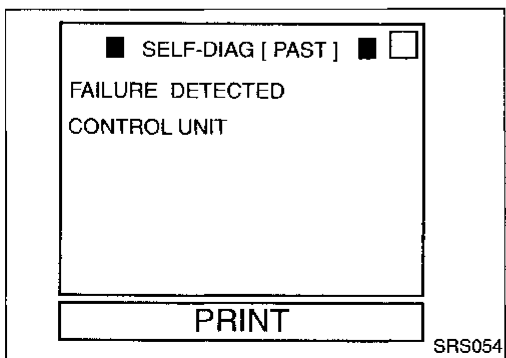

7. If diagnostic codes are displayed on "SELF-DIAG [PAST]", go to step 10.

GI

MA

EM

LC

EC

FE

CL

MT

AT

TF

PD

FA

RA

BR

ST

RS

BT

HA

EL

IDX

TROUBLE DIAGNOSES — Supplemental Restraint System (SRS)

Trouble Diagnoses with CONSULT (Cont'd)

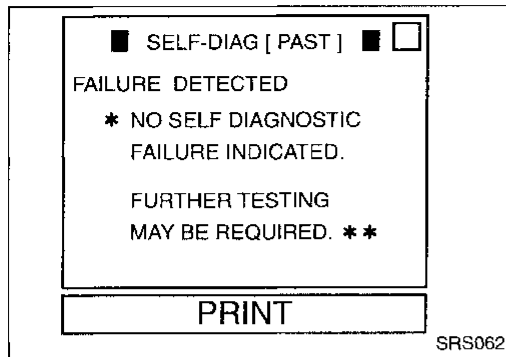

■ SELF-DIAG [PAST] ■

FAILURE DETECTED

* NO SELF DIAGNOSTIC FAILURE INDICATED.

FURTHER TESTING MAY BE REQUIRED. **

PRINT

SRS062

If no self-diagnostic failure is detected on “SELF-DIAG [PAST]”, touch “BACK” and go back to “SELECT DIAG MODE”.

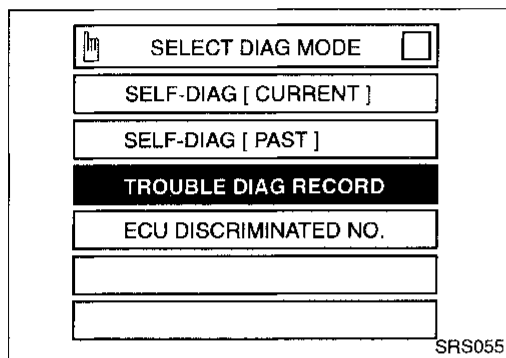

 SELECT DIAG MODE

SELF-DIAG [CURRENT]

SELF-DIAG [PAST]

TROUBLE DIAG RECORD

ECU DISCRIMINATED NO.

SRS055

8. Touch “TROUBLE DIAG RECORD”.

NOTE:

With “TROUBLE DIAG RECORD”, diagnosis results previously erased by a reset operation can be displayed.

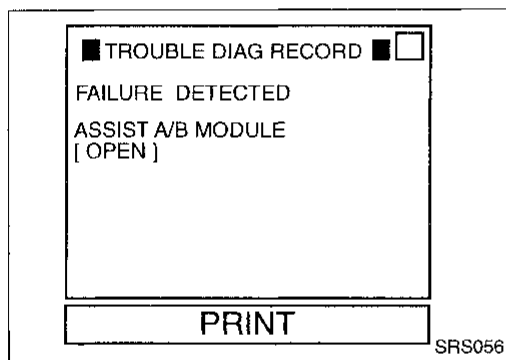

■ TROUBLE DIAG RECORD ■

FAILURE DETECTED

ASSIST A/B MODULE [OPEN]

PRINT

SRS056

9. Diagnostic code is displayed on “TROUBLE DIAG RECORD”.

10. Touch “PRINT”.
11. Compare diagnostic codes to the INTERMITTENT PROBLEM DIAGNOSTIC CODE CHART, RS-43.
12. Touch “BACK” key of CONSULT until “SELECT SYSTEM” appears, then turn off CONSULT.
13. Turn ignition switch OFF, then disconnect CONSULT and both battery cables.
14. Repair the system as outlined by the Repair order that corresponds to the problem code in INTERMITTENT PROBLEM DIAGNOSTIC CODE CHART, RS-43. For replacement procedure of component parts, refer to RS-14.
15. Go to DIAGNOSTIC PROCEDURE 3, RS-39.

TROUBLE DIAGNOSES — Supplemental Restraint System (SRS)

📱 Trouble Diagnoses with CONSULT (Cont'd)

INTERMITTENT PROBLEM DIAGNOSTIC CODE CHART (“SELF-DIAG [PAST]” or “TROUBLE DIAG RECORD”)

Diagnostic item	Explanation	Repair order
NO SELF DIAGNOSTIC FAILURE INDICATED.	● No malfunction is detected.	● Go to DIAGNOSTIC PROCEDURE 3, RS-39.
AIRBAG MODULE [OPEN]	● Driver air bag module circuit is open (including the spiral cable).	<ol style="list-style-type: none"> 1. Visually check wiring harness connections. 2. Replace air bag harness if it has visible damage. 3. If the harness check result is OK, replace driver air bag module (Before disposal of it, it must be deployed.), air bag diagnosis sensor unit and spiral cable.
AIRBAG MODULE [VB-SHORT]	● Driver air bag module circuit is shorted to some power supply circuit (including the spiral cable).	
AIRBAG MODULE [GND-SHORT]	● Driver air bag module circuit is shorted to ground (including the spiral cable).	
AIRBAG MODULE [SHORT]	● Driver air bag module circuits are shorted to each other.	
ASSIST A/B MODULE [VB-SHORT]	● Passenger air bag module circuit is shorted to some power supply circuit.	<ol style="list-style-type: none"> 1. Visually check wiring harness connections. 2. Replace air bag harness if it has visible damage. 3. If the harness check result is OK, replace air bag diagnosis sensor unit and air bag harness.
ASSIST A/B MODULE [OPEN]	● Passenger air bag module circuit is open.	<ol style="list-style-type: none"> 1. Visually check wiring harness connections. 2. Replace air bag harness if it has visible damage. 3. If the harness check result is OK, replace passenger air bag module (Before disposal of it, it must be deployed.) and air bag diagnosis sensor unit.
ASSIST A/B MODULE [GND-SHORT]	● Passenger air bag module circuit is shorted to ground.	
ASSIST A/B MODULE [SHORT]	● Passenger air bag module circuits are shorted to each other.	
CRASH ZONE SEN-CTR [OPEN/UPR-VB-SHORT] (4WD models)	<ul style="list-style-type: none"> ● Crash zone sensor circuit is open, or ● Crash zone sensor circuit is shorted to some power supply circuit. 	<ol style="list-style-type: none"> 1. Visually check wiring harness connections. 2. Replace air bag harness if it has visible damage.
CRASH ZONE SEN-CTR [SHORT/UPR-GND-SHORT] (4WD models)	<ul style="list-style-type: none"> ● Both crash zone sensor circuits are shorted, or ● Crash zone sensor circuit is shorted to ground. 	<ol style="list-style-type: none"> 1. Visually check wiring harness connections. 2. Replace harness if it has visible damage. 3. If the harness check result is OK, replace crash zone sensor.
CONTROL UNIT	● Low battery voltage (Less than 9V).	● Go to DIAGNOSTIC PROCEDURE 3 (RS-39).
	● Air bag diagnosis sensor unit is malfunctioning.	● Replace air bag diagnosis sensor unit.
PASS A/B DEACT SW	● Activate terminal is open.	<ol style="list-style-type: none"> 1. Visually check wiring harness connections. 2. Replace harness if it has visible damage. 3. If the harness check result is OK, replace passenger air bag deactivation switch (The key cylinder of passenger air bag deactivation switch does not have to be replaced.).
	● Activate terminal is shorted to ground.	
	● Deactivate terminal is open.	
	● Deactivate terminal is shorted to ground.	
	● Activate terminal and deactivate terminal are shorted to each other.	
PASS A/B DEACT SW INDICATOR	● Passenger air bag deactivation switch indicator circuit is open.	<ol style="list-style-type: none"> 1. Visually check wiring harness connections. 2. Replace harness if it has visible damage. 3. If the harness check result is OK, replace passenger air bag deactivation switch indicator.
	● Passenger air bag deactivation switch indicator circuit is shorted to some power supply circuit.	
	● Passenger air bag deactivation switch indicator circuit is shorted to ground.	
INDEFINITE FAILURES [AIR BAGS]	● Passenger air bag deactivation switch status is not identified.	<ol style="list-style-type: none"> 1. Visually check wiring harness connections. 2. Replace harness if it has visible damage. 3. If the harness check result is OK, replace passenger air bag deactivation switch and air bag diagnosis sensor unit.

*Follow the procedures in numerical order when repairing malfunctioning parts. Confirm whether malfunction is eliminated using the “AIR BAG” warning lamp (in User mode) or CONSULT each time repair is finished. If malfunction is still observed, proceed to the next step. When malfunction is eliminated, further repair work is not required.

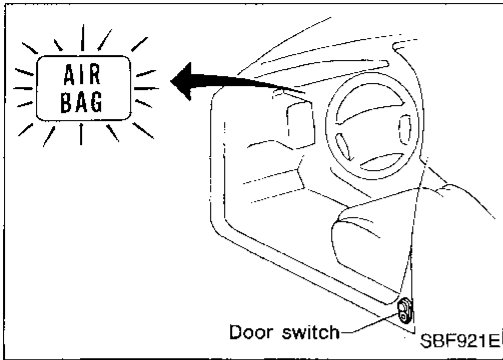

⊗ Trouble Diagnoses without CONSULT

DIAGNOSTIC PROCEDURE 6

Inspecting SRS malfunctioning parts by using "AIR BAG" warning lamp — Diagnosis mode

NOTE:

SRS will not enter Diagnosis mode if no malfunction is detected in User mode.

1. Open driver's door.
2. Turn ignition switch from OFF to ON.
3. Press door switch LH at least 5 times within 7 seconds after turning ignition switch ON.
SRS is now in Diagnosis mode.
4. "AIR BAG" warning lamp operates in Diagnosis mode as follows:

NOTE:

If SRS does not enter Diagnosis mode even though malfunction is detected in User mode, go to DIAGNOSTIC PROCEDURE 11, RS-50.

No.	"AIR BAG" warning lamp operation — Diagnosis mode —	SRS condition
1		<ul style="list-style-type: none"> ● Self-diagnostic failure (previously stored in the memory) might not be erased after repair. ● Intermittent problem has been detected in the past. <p>Go to DIAGNOSTIC PROCEDURE 8, RS-48.</p>
2		<p>The system has a problem and needs to be repaired.</p>

5. Malfunctioning part is indicated by the number of flashes (part (d)). Compare the number of flashes to WARNING LAMP FLASH CODE CHART and locate malfunctioning part.
6. Turn ignition switch OFF, and disconnect both battery cables.
7. Repair the system as outlined by the Repair order in WARNING LAMP FLASH CODE CHART that corresponds to the flash code. For replacement procedure of component parts, refer to RS-14.
8. After repairing the system, go to DIAGNOSTIC PROCEDURE 7, RS-46.

TROUBLE DIAGNOSES — Supplemental Restraint System (SRS)



Trouble Diagnoses without CONSULT (Cont'd)

WARNING LAMP FLASH CODE CHART

Warning lamp	Flash code ^(d) (# of flashes)	Explanation	Repair order *Recheck SRS at each replacement
"AIR BAG" warning lamp	0	<ul style="list-style-type: none"> Self-diagnostic failure might not be erased after repair. Intermittent problem has been detected in the past. 	<ul style="list-style-type: none"> Go to DIAGNOSTIC PROCEDURE 8 (RS-48).
	2	<ul style="list-style-type: none"> Driver air bag module circuit is malfunctioning. 	<ol style="list-style-type: none"> Visually check wiring harness connections. Replace air bag harness if it has visible damage. Replace spiral cable. Replace driver air bag module. (Before disposing of it, it must be deployed.) Replace air bag diagnosis sensor unit. Replace air bag harness.
	6	<ul style="list-style-type: none"> Crash zone sensor (4WD models) is malfunctioning. 	<ol style="list-style-type: none"> Visually check wiring harness connections. Replace air bag harness if it has visible damage. Replace crash zone sensor. Replace air bag diagnosis sensor unit. Replace air bag harness for crash zone sensor.
	7	<ul style="list-style-type: none"> Low battery voltage (Less than 9V). 	<ul style="list-style-type: none"> Go to DIAGNOSTIC PROCEDURE 7 (RS-46).
		<ul style="list-style-type: none"> Air bag diagnosis sensor unit is malfunctioning. 	<ol style="list-style-type: none"> Visually check wiring harness connections. Replace air bag diagnosis sensor unit. Replace air bag harness.
	8	<ul style="list-style-type: none"> Passenger air bag module circuit is malfunctioning. 	<ol style="list-style-type: none"> Visually check wiring harness connections. Replace air bag harness if it has visible damage. Replace passenger air bag module. (Before disposal of it, it must be deployed.) Replace air bag diagnosis sensor unit. Replace air bag harness.
	9	<ul style="list-style-type: none"> Passenger air bag deactivation switch status is not identified. 	<ol style="list-style-type: none"> Visually check wiring harness connections. Replace air bag harness if it has visible damage. Replace passenger air bag deactivation switch. (The key cylinder of passenger air bag deactivation switch does not have to be replaced.) Replace air bag diagnosis sensor unit. Replace air bag harness.
	10	<ul style="list-style-type: none"> Passenger air bag deactivation switch is malfunctioning. 	<ol style="list-style-type: none"> Visually check wiring harness connections. Replace air bag harness if it has visible damage. Replace passenger air bag deactivation switch. (The key cylinder of passenger air bag deactivation switch does not have to be replaced.) Replace air bag diagnosis sensor unit. Replace air bag harness.
	11	<ul style="list-style-type: none"> Passenger air bag deactivation switch indicator is malfunctioning. 	<ol style="list-style-type: none"> Visually check wiring harness connections. Replace air bag harness if it has visible damage. Replace passenger air bag deactivation switch indicator. Replace air bag diagnosis sensor unit. Replace air bag harness.

*Follow the procedures in numerical order when repairing malfunctioning parts. Confirm whether malfunction is eliminated using the "AIR BAG" warning lamp (in User mode) or CONSULT each time repair is finished. If malfunction is still observed, proceed to the next step. When malfunction is eliminated, further repair work is not required.

 Trouble Diagnoses without CONSULT
(Cont'd)

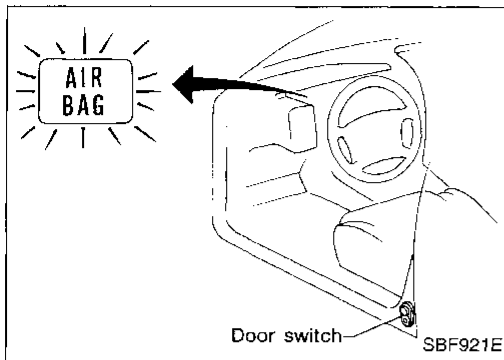

DIAGNOSTIC PROCEDURE 7

Final checking after repairing SRS by using "AIR BAG" warning lamp — Diagnosis mode and User mode

1. After repairing SRS, connect both battery cables.
2. Open driver's door.
3. Turn ignition switch from OFF to ON.
4. "AIR BAG" warning lamp operates in Diagnosis mode as follows:

No.	"AIR BAG" warning lamp operation — Diagnosis mode —	SRS condition
1	<p style="text-align: right;">(a) through (b) are repeated.</p> <p style="text-align: right;">MRS100A</p>	<p>No malfunction is detected or repair is completed. No further action is necessary.</p>
2	<p style="text-align: right;">(a) through (d) are repeated.</p> <p style="text-align: right;">NOTE: (a) — Interval I (b) — Start signal (Start signal identifies display modes) (c) — Interval II (d) — Indicates malfunctioning part (0.5 sec. ON and 0.5 sec. OFF is counted as one flash.)</p> <p style="text-align: right;">MRS099A</p>	<p>The system has a problem and needs to be repaired.</p>

NOTE:
 When diagnosis sensor unit is replaced with a new one; the "AIR BAG" warning lamp will operate in User mode. Checking the "AIR BAG" warning lamp operation in Diagnosis mode is not required. Go to step 6.



5. If "AIR BAG" warning lamp operates as shown in No. 1 in the chart above, turn ignition switch OFF to reset from Diagnosis mode to User mode and to erase the memory of the malfunction.

If "AIR BAG" warning lamp operates as in No. 2 in the chart above, the malfunctioning part is not repaired completely, or another malfunctioning part is detected. Go to DIAGNOSTIC PROCEDURE 6, RS-44 and repair malfunctioning part completely.

**⌚ Trouble Diagnoses without CONSULT
(Cont'd)**

6. Turn ignition switch ON. "AIR BAG" warning lamp operates in User mode. Compare "AIR BAG" warning lamp operation to the chart below.

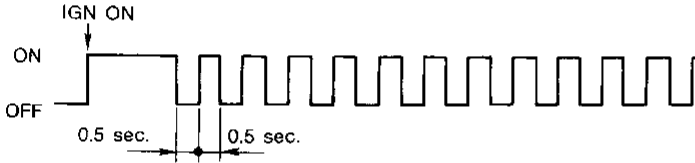
NOTE:
If switching Diagnosis mode to User mode is required while malfunction is being detected, turn ignition switch from OFF to ON. Then press door switch LH at least 5 times within 7 seconds after turning ignition switch ON. SRS is now in User mode.

"AIR BAG" warning lamp operation — User mode —	SRS condition	Reference item
 <p>MRS095A</p>	No malfunction is detected. No further action is necessary.	—
 <p>MRS096A</p>	The system has problem and needs to be repaired as indicated.	Go to DIAGNOSTIC PROCEDURE 2 or 6, RS-34 or 44.
 <p>MRS097A</p>	Air bag is deployed. Air bag fuse for air bag diagnosis sensor unit or circuit is malfunctioning and needs to be repaired.	Go to COLLISION DIAGNOSIS, RS-51. Go to DIAGNOSTIC PROCEDURE 9, RS-48.
 <p>MRS098A</p>	One of the following has occurred and needs to be repaired. <ul style="list-style-type: none"> ● Meter fuse is open. ● "AIR BAG" warning lamp circuit is shorted or open. ● Air bag diagnosis sensor unit is malfunctioning. 	Go to DIAGNOSTIC PROCEDURE 10, RS-49.

GI
MA
EM
LC
EC
FE
CL
MT
AT
TF
PD
FA
RA
BR
ST
BT
HA
EL
IDX

RS

Trouble Diagnoses without CONSULT (Cont'd)

DIAGNOSTIC PROCEDURE 8 (Continued from DIAGNOSTIC PROCEDURE 6)

Inspection SRS malfunctioning record

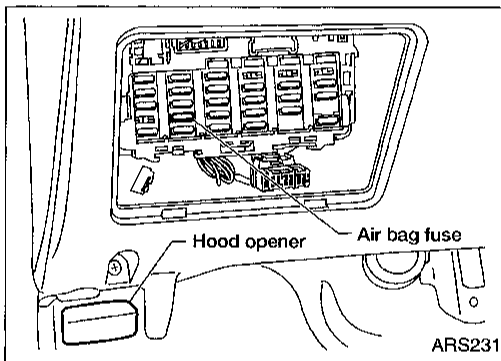
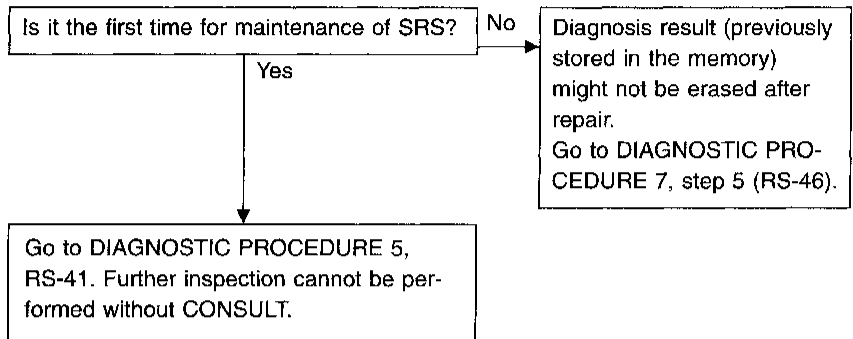

Trouble Diagnoses: "AIR BAG" Warning Lamp Does Not Turn Off

DIAGNOSTIC PROCEDURE 9

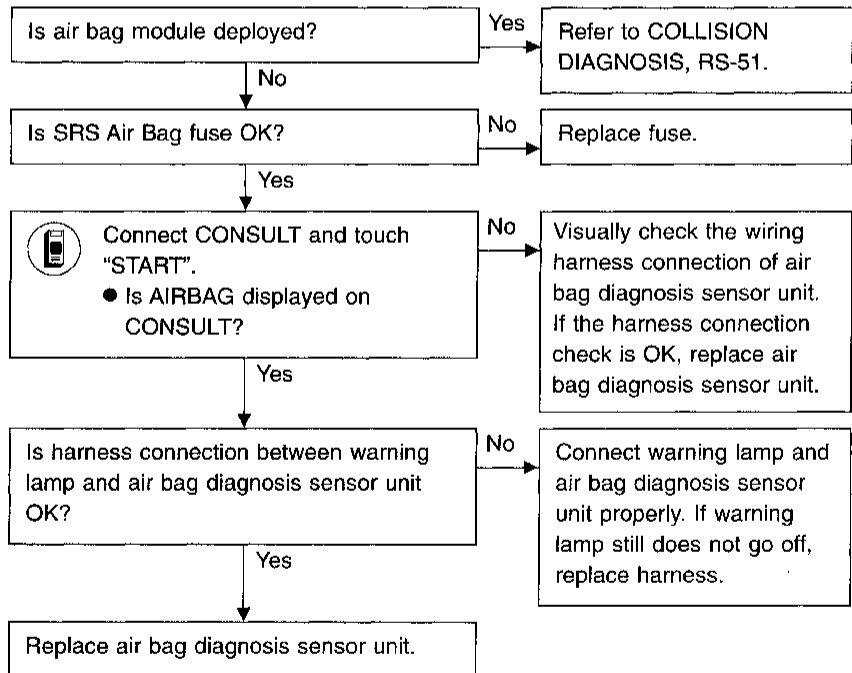
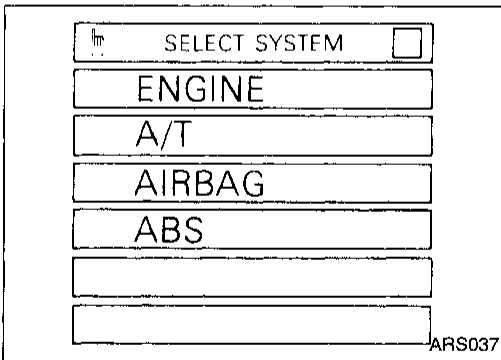

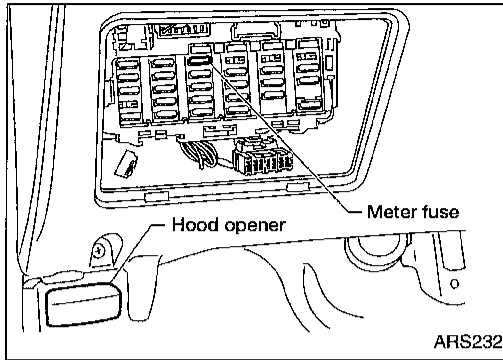

Trouble Diagnoses: "AIR BAG" Warning Lamp Does Not Turn On

DIAGNOSTIC PROCEDURE 10

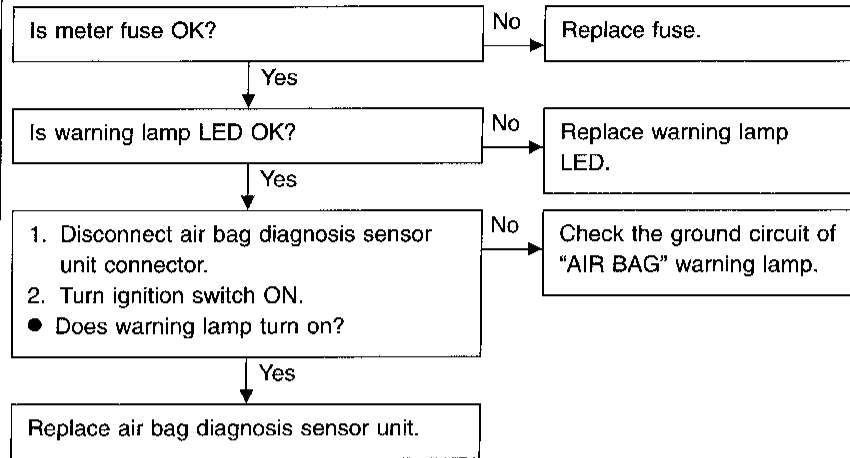

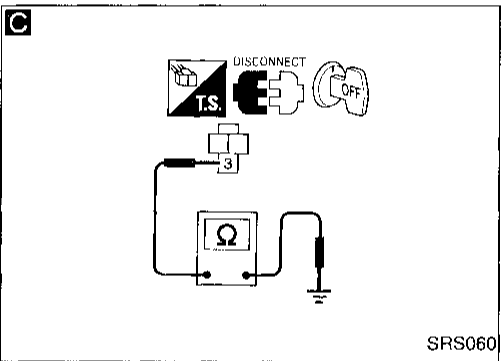
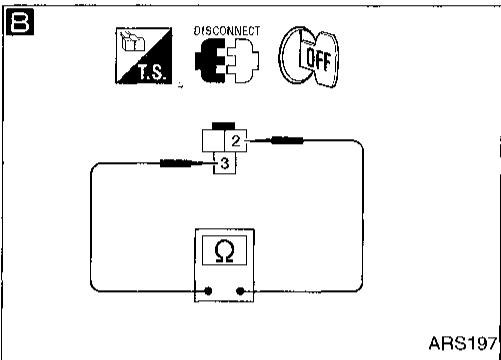
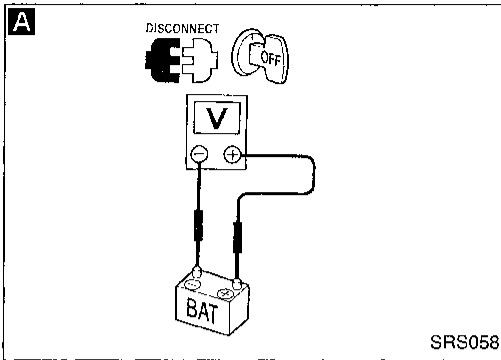

Trouble Diagnoses: SRS Does Not Enter Diagnosis Mode Using Door Switch DIAGNOSTIC PROCEDURE 11

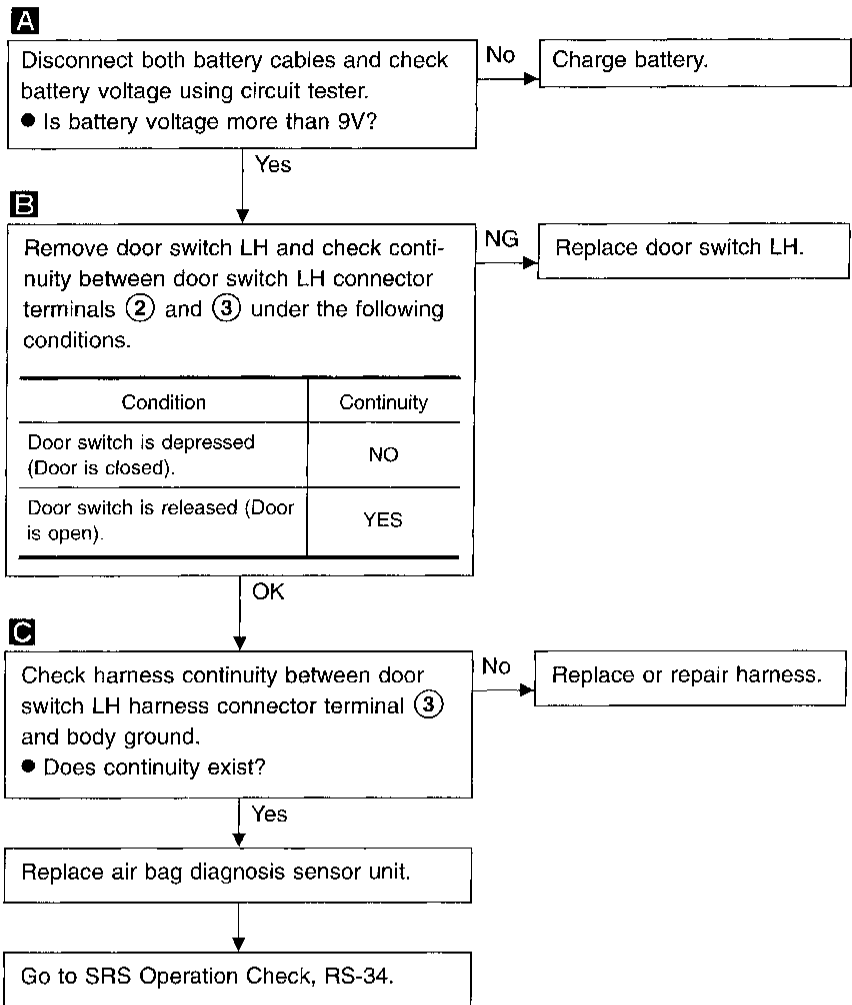

COLLISION DIAGNOSIS

To repair the SRS, perform the following steps.

When SRS is activated in a collision:

- ① Replace the air bag diagnosis sensor unit.
- ② Remove the air bag modules.
- ③ Check the SRS components using the table shown on the next page.
 - Replace any SRS components showing visible signs of damage (dents, cracks and deformation).
- ④ Install new air bag modules.
- ⑤ Conduct Self-diagnosis. Refer to "SRS Operation Check", RS-34. Ensure the remainder of the SRS operates properly.

When SRS is not activated in a collision:

- ① Check the SRS components using the table shown on the next page.
 - Replace any SRS components showing visible signs of damage (dents, cracks and deformation).
- ② Conduct Self-diagnosis using CONSULT and "AIR BAG" warning lamp. Refer to "SRS Operation Check", RS-34. Ensure entire SRS operates properly.

GI

MA

EM

LC

EC

FE

CL

MT

AT

TF

PD

FA

RA

BR

ST

RS

BT

HA

EL

IDX

COLLISION DIAGNOSIS

SRS inspection

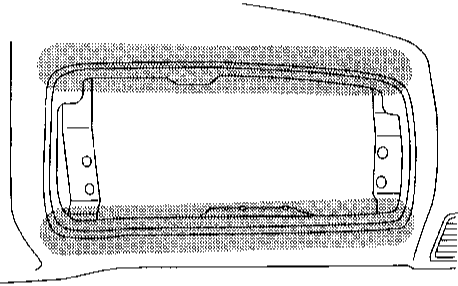
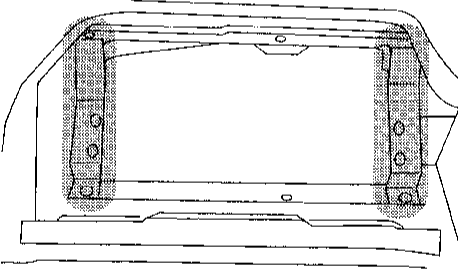
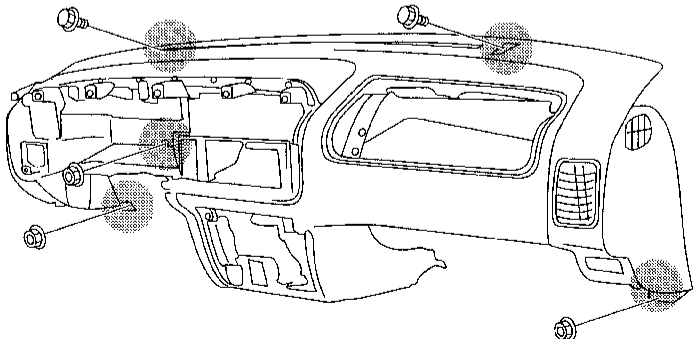
Part	SRS is activated	SRS is NOT activated
Air bag module (driver and passenger side)	REPLACE Install with new bolts.	<ol style="list-style-type: none"> 1. Remove air bag module. Check harness cover and connectors for damage, terminals for deformities, and harness for binding. 2-1. Install driver air bag module into the steering wheel to check fit and alignment with the wheel. 2-2. Install passenger air bag module into the instrument panel to check fit with the instrument panel. 3. No damage found, reinstall with new bolts. 4. If damaged—REPLACE. Air bag must be deployed before discarding.
Crash zone sensor (4WD models)	<ol style="list-style-type: none"> 1. Check body and sensor bracket for deformities and rust. 2. Check sensor case for dents, cracks, scratches, deformities and rust. 3. Check sensor harness, connector, and terminals for binding, damage, and deformities. 4. If no damage is found, reinstall with new bolts. 5. If damaged—REPLACE. 	
Instrument panel	<ol style="list-style-type: none"> 1. When passenger air bag inflates, check the following points for bending, deformities and cracks: <ul style="list-style-type: none"> ● Opening portion for passenger air bag <div style="text-align: center; margin: 10px 0;">  <p>● : Check points</p> </div> <ul style="list-style-type: none"> ● Passenger air bag module brackets <div style="text-align: center; margin: 10px 0;">  <p>● : Check points</p> </div> <ul style="list-style-type: none"> ● The portions securing the instrument panel <div style="text-align: center; margin: 10px 0;">  <p>● : Check points</p> </div> <ol style="list-style-type: none"> 2. If no damage is found, reinstall the instrument panel. 3. If damaged - REPLACE the instrument panel with new bolts. 	

COLLISION DIAGNOSIS

Part	SRS is activated	SRS is NOT activated	GI
Air bag diagnosis sensor unit	REPLACE Install with new bolts.	1. Check case and bracket for dents, cracks or deformities. 2. Check connectors for damage, and terminals for deformities. 3. If no damage is found, reinstall with new bolts. 4. If damaged—REPLACE.	MA
Steering wheel	1. Visually check steering wheel for deformities. 2. Check harness (built into steering wheel) and connectors for damage, and terminals for deformities. 3. Install air bag module to check fit or alignment with steering wheel. 4. Check steering wheel for excessive free play. 5. If no damage is found, reinstall the steering wheel. 6. If damaged—REPLACE.		EM LC
Spiral cable	1. Visually check spiral cable and combination switch for damage. 2. Check connectors, flat cable and protective tape for damage. 3. Check steering wheel for noise, binding or heavy operation. 4. If no damage is found, reinstall the spiral cable. 5. If damaged—REPLACE.		EC FE
Passenger air bag deactivation switch and indicator	1. Visually check passenger air bag deactivation switch and indicator for dents, cracks and deformities. 2. Check the harness and connectors for damage, and terminals for deformities. 3. If damaged—REPLACE. WARNING: After SRS maintenance or repair, make sure the passenger air bag deactivation switch is in the same position (ON or OFF) as when the vehicle arrived for service.		CL MT AT
Harness and Connectors	1. Check connectors for poor connection, damage, and terminals for deformities. 2. Check harness for binding, chafing, cuts and deformities. 3. If no damage is found, reinstall. 4. Damaged—REPLACE damaged section of harness. Do not attempt to repair, splice or modify any SRS harness.		TF PD FA RA BR ST RS BT HA FI IDX