

SECTION **RA**

CONTENTS

PRECAUTIONS AND PREPARATION2	Wheel Bearing.....10	
Precautions.....2	Axle Case.....10	CL
Special Service Tools.....2	Installation — 2WD models —.....10	
Commercial Service Tools.....3	Installation — 4WD models —.....12	MT
NOISE, VIBRATION AND HARSHNESS (NVH)	REAR SUSPENSION14	
TROUBLESHOOTING4	2WD models.....14	AT
NVH Troubleshooting Chart.....4	4WD models.....14	
REAR AXLE AND REAR SUSPENSION5	Shock Absorber.....15	TF
2WD models.....5	Removal And Installation.....15	
4WD models.....5	Inspection.....15	PD
ON-VEHICLE SERVICE6	Leaf Spring.....15	
Rear Axle and Rear Suspension Parts.....6	Removal And Installation.....15	FA
Rear Wheel Bearing.....6	Inspection.....16	
REAR AXLE7	Installation.....16	
Components.....7	SERVICE DATA AND SPECIFICATIONS (SDS)17	
Removal.....8	General Specifications.....17	
Inspection.....10	Inspection and Adjustment.....17	
Axle Shaft.....10		RA

GI
MA
EM
LC
EC
FE
CL
AT
TF
PD
FA
BR
ST
RS
BT
HA
EL
IDX

PRECAUTIONS AND PREPARATION

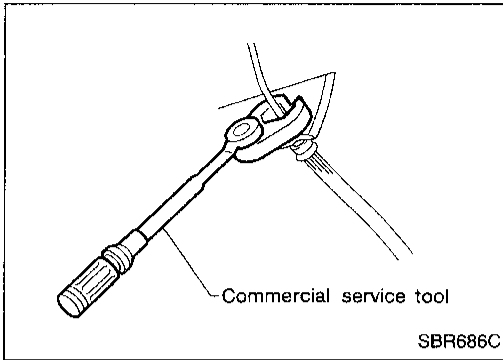

Precautions

- When installing rubber parts, final tightening must be carried out under unladen condition* with tires on ground.
- *: Fuel, radiator coolant and engine oil full. Spare tire, jack, hand tools and mats in designated positions.
- Use flare nut wrench when removing and installing brake tubes.
- After installing removed suspension parts, check wheel alignment and adjust if necessary.
- Always torque brake lines when installing.

Special Service Tools

The actual shapes of Kent-Moore tools may differ from those of special service tools illustrated here.

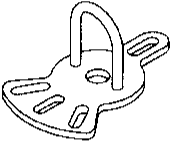
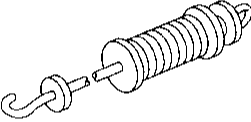
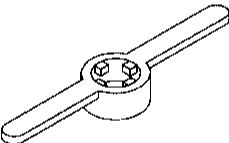
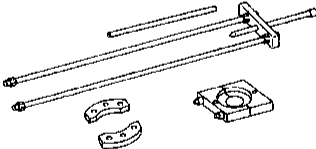
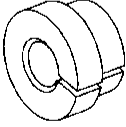
Tool number Kent-Moore No. Tool name	Description
KV40101000 (J25604-01) Axle stand	 Removing rear axle shaft NT159
ST36230000 (J25840-A) Sliding hammer	 Removing rear axle shaft NT126
ST38020000 (—) Bearing lock nut wrench	 Removing wheel bearing lock nut NT160
KV40106500 (J25852-B) Rear axle shaft bearing puller	 Removing wheel bearing and ABS sensor rotor NT683
ST37840000 (—) Rear axle shaft guide	 Installing rear axle shaft NT162

PRECAUTIONS AND PREPARATION

Commercial Service Tools

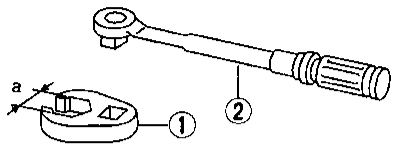
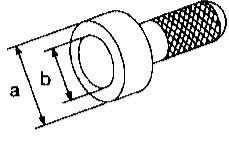
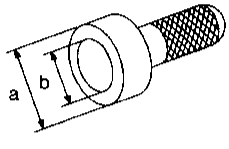
Tool name	Description
① Flare nut crowfoot ② Torque wrench	 <p>NT360</p> <p>a: 10 mm (0.39 in)</p>
Bearing cage oil seal drift	 <p>NT115</p> <p>a: 74 mm (2.91 in) dia. b: 68 mm (2.68 in) dia.</p>
Rear axle oil seal drift	 <p>NT115</p> <p>a: 54.5 mm (2.15 in.) b: 34.5 mm (1.36 in.)</p>

GI

MA

EM

LC

EC

FE

CL

MT

AT

TF

PD

FA

RA

BR

ST

RS

BT

HA

EL

IDX

NOISE, VIBRATION AND HARSHNESS (NVH) TROUBLESHOOTING

NVH Troubleshooting Chart

Use the chart below to help you find the cause of the symptom. If necessary, repair or replace these parts.

Reference page		RA-5	RA-15	—	—	—	RA-14	RA-6	NVH in PD section	NVH in PD section	NVH in FA section	NVH in FA section	NVH in FA section	NVH in FA section	NVH in BR section	NVH in ST section	
Possible cause and SUSPECTED PARTS		Improper installation, Looseness	Shock absorber deformation, damage or deflection	Bushing or mounting deterioration	Parts interference	Spring fatigue	Suspension looseness	Wheel bearing damage	PROPELLER SHAFT	DIFFERENTIAL	DRIVESHAFT	FRONT AXLE AND FRONT SUSPENSION	TIRES	ROAD WHEEL	BRAKES	STEERING	
Symptom	REAR AXLE AND REAR SUSPENSION	Noise	X	X	X	X	X		X	X	X	X	X	X	X	X	
		Shake	X	X	X	X		X			X	X	X	X	X	X	
		Vibration	X	X	X	X	X			X		X	X				X
		Shimmy	X	X	X	X							X	X	X	X	X
		Judder	X	X	X								X	X	X	X	X
		Poor quality ride or handling	X	X	X	X	X		X				X	X	X		

X : Applicable

REAR AXLE AND REAR SUSPENSION

2WD models

SEC. 380 • 430 • 431

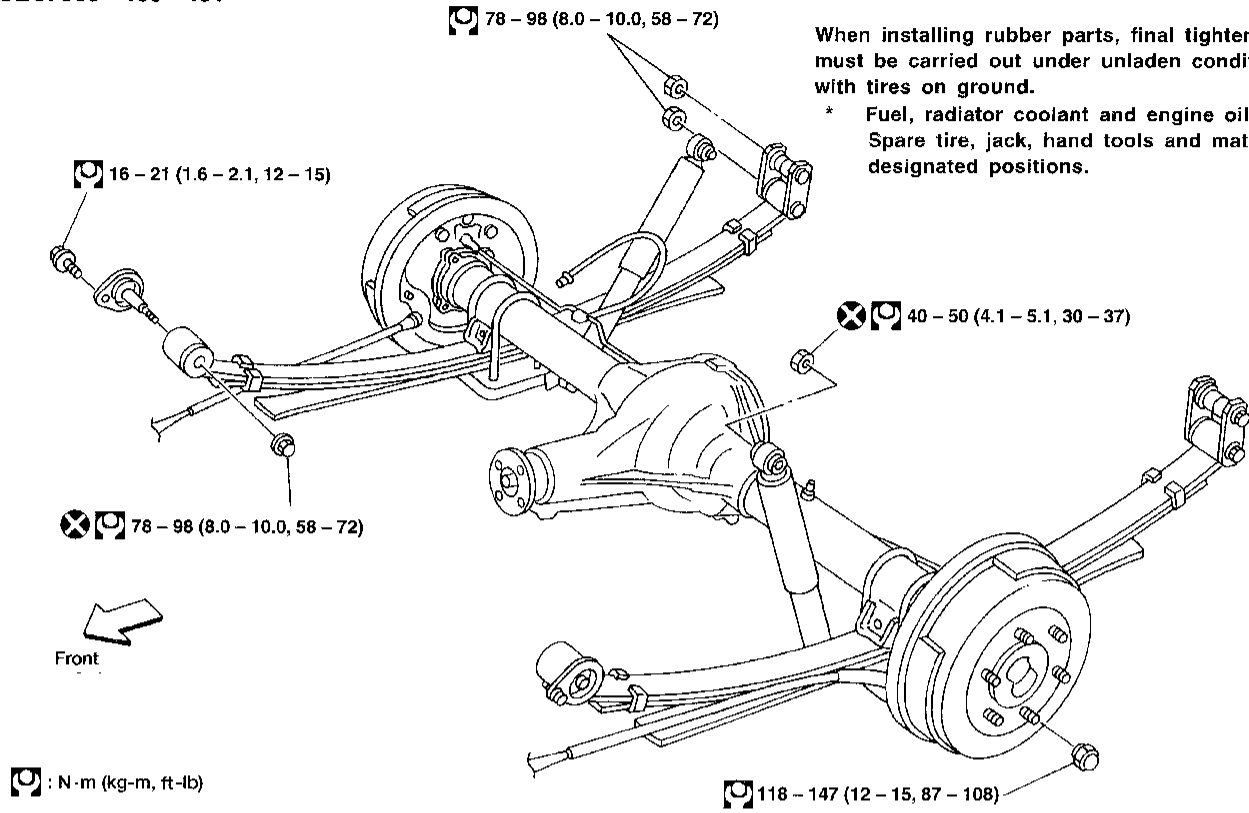

When installing rubber parts, final tightening must be carried out under unladen condition* with tires on ground.

* Fuel, radiator coolant and engine oil full. Spare tire, jack, hand tools and mats in designated positions.

ARA104

4WD models

SEC. 380 • 430 • 431

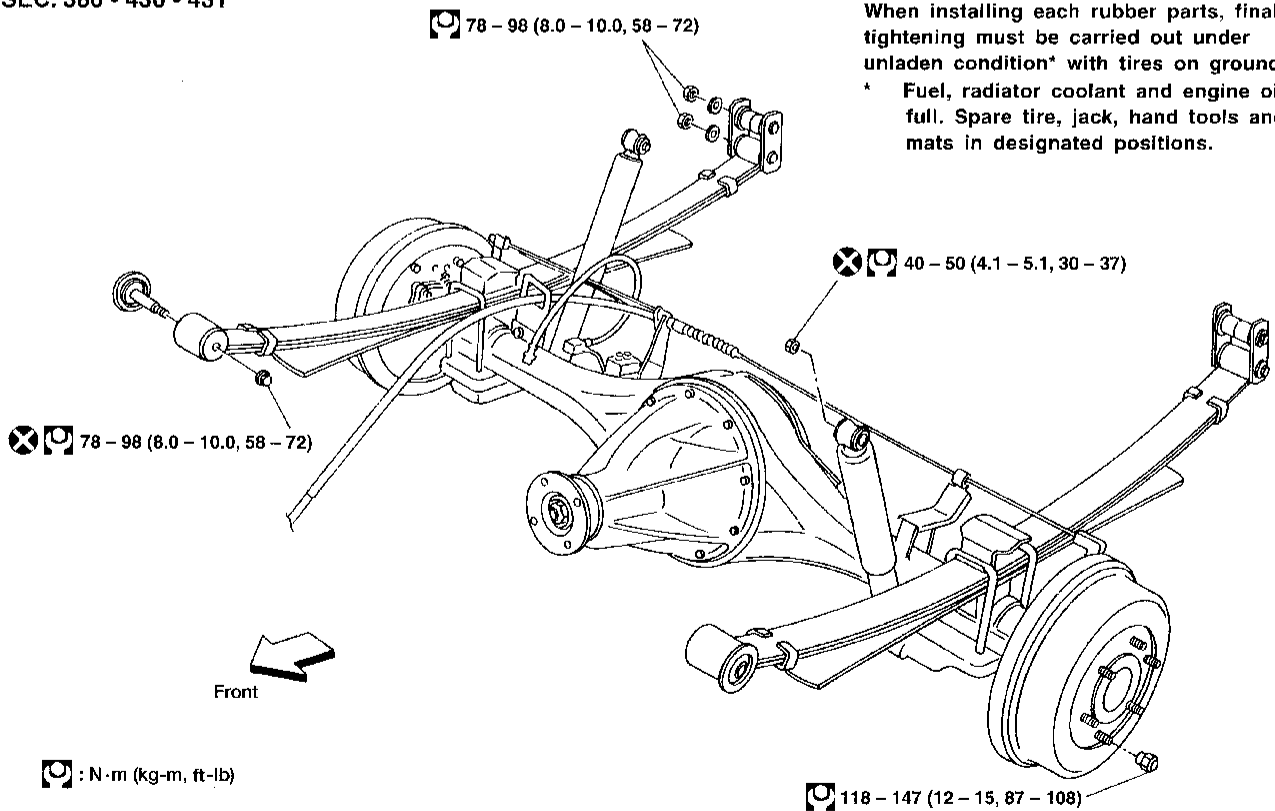

When installing each rubber parts, final tightening must be carried out under unladen condition* with tires on ground.

* Fuel, radiator coolant and engine oil full. Spare tire, jack, hand tools and mats in designated positions.

ARA101

GI
MA
EM
LC
EC
FE
CL
MT
AT
TF
PD
FA
RA
BR
ST
RS
BT
HA
EL
IDX

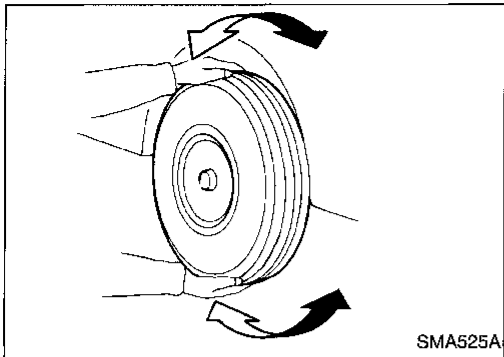

Rear Axle and Rear Suspension Parts

Check rear axle and rear suspension parts for excessive play, wear and damage.

- Shake each rear wheel to check for excessive play.

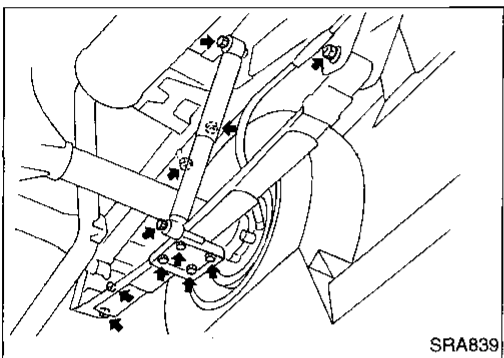

- Retighten all nuts and bolts to the specified torque.
☞: Refer to REAR SUSPENSION, RA-14.

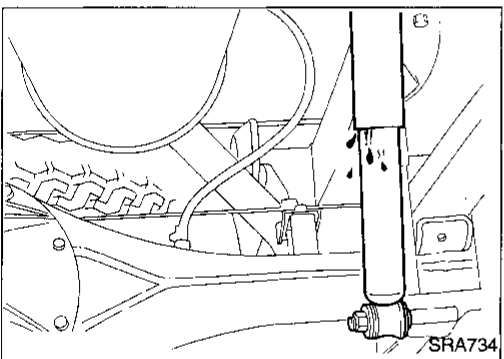

- Check shock absorber for oil leakage and other damage.
- Check shock absorber bushing for excessive wear and other damage.

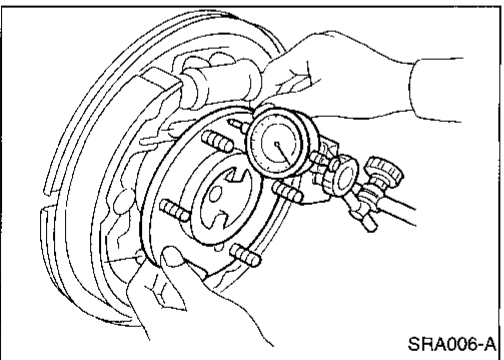

Rear Wheel Bearing

- Check that wheel bearings operate smoothly.
- Check axial end play.

Axial end play:

Refer to SDS, RA-17.

REAR AXLE

Components

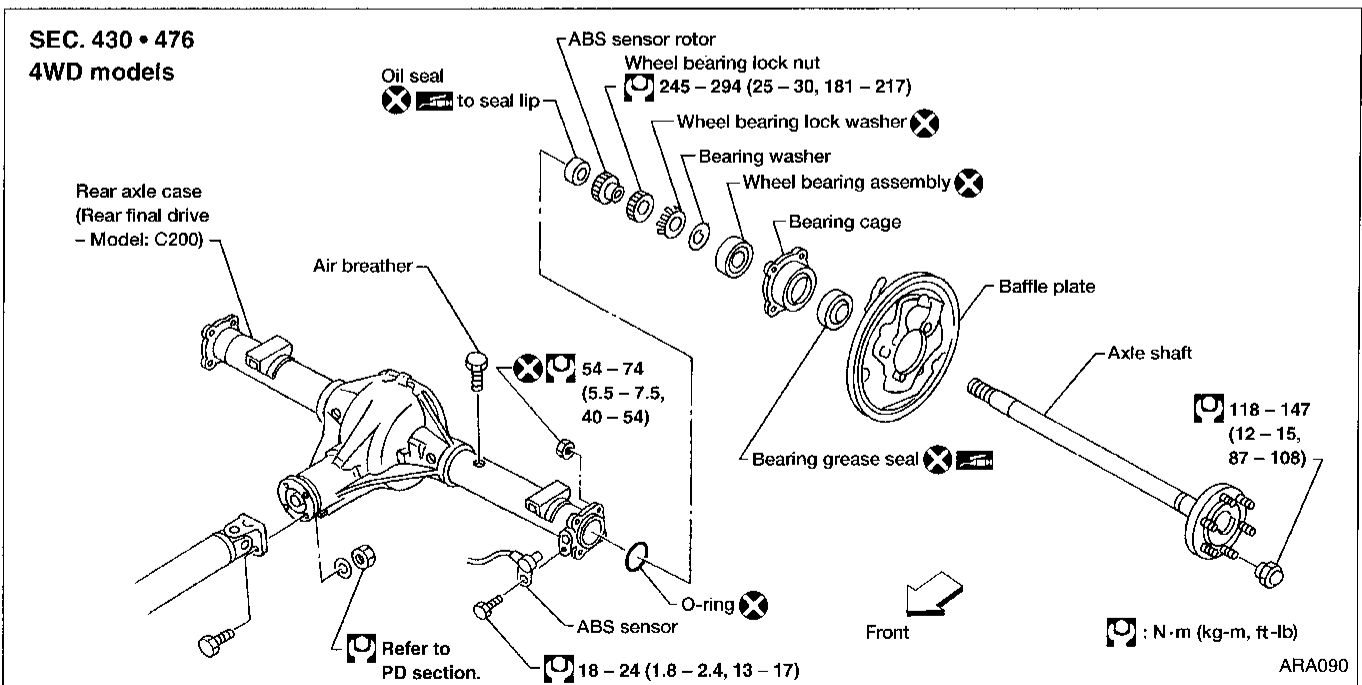
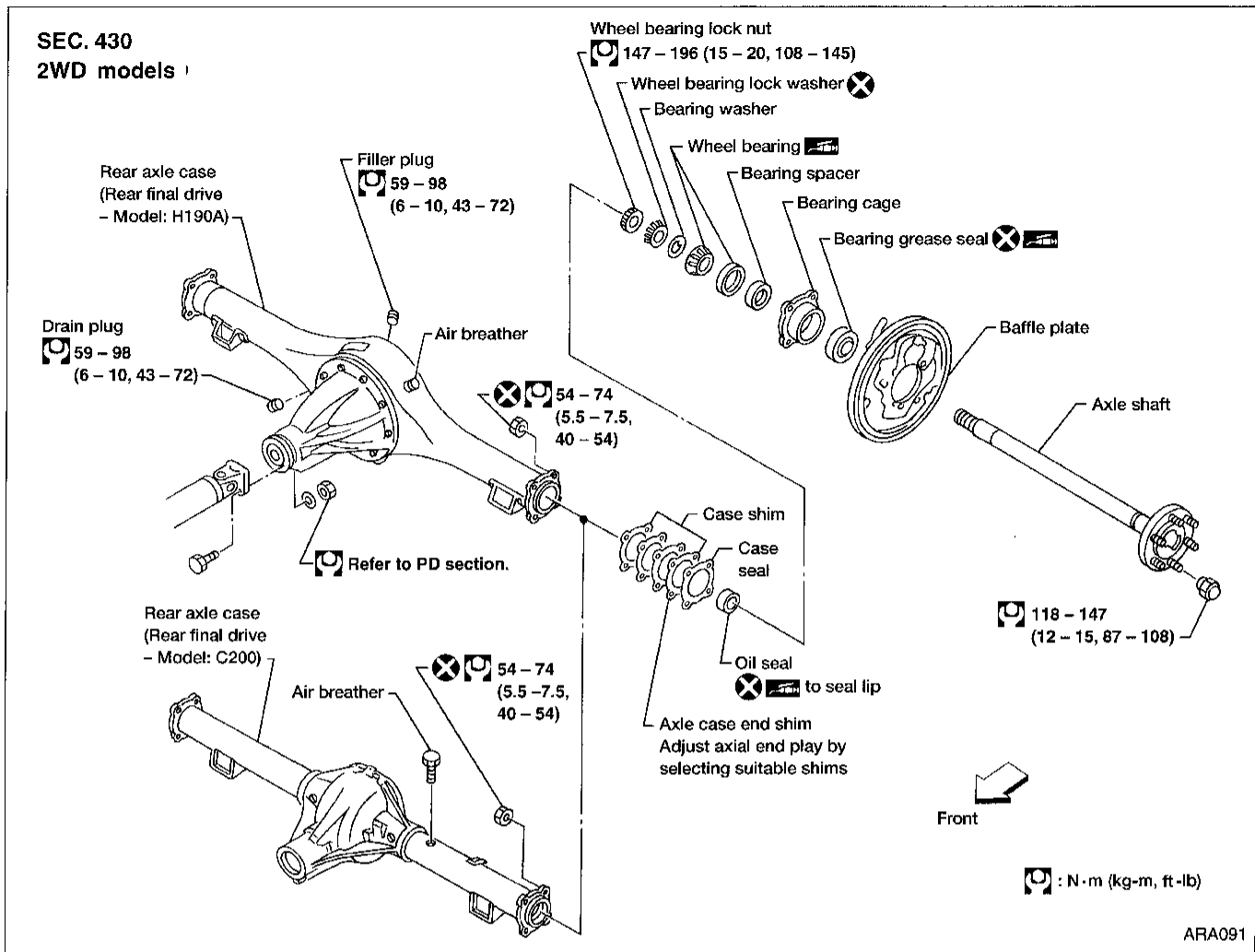

GI

MA

EM

LC

EC

FE

CL

MT

AT

TF

PD

FA

RA

BR

ST

RS

BT

HA

EL

IDX

REAR AXLE

Removal

- Before removing the rear axle, disconnect the ABS wheel sensor from the assembly. Then move it away from the axle. Failure to do so may result in damage to the sensor wires and the sensor becoming inoperative.
- Wheel bearing does not require maintenance. — 4WD models —
- If growling noise is emitted from wheel bearing during operation, replace wheel bearing assembly.
- If the wheel bearing assembly is removed, it must be replaced. The old assembly must not be re-used.

1. Disconnect parking brake cable and brake tube.
2. Remove nuts securing wheel bearing cage with baffle plate.

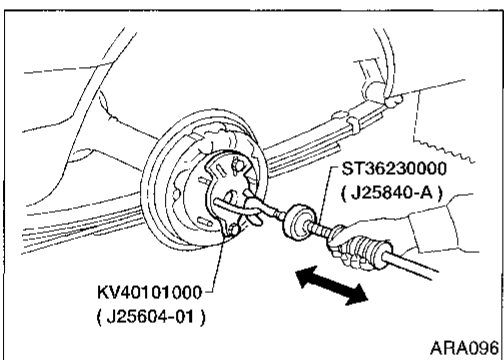
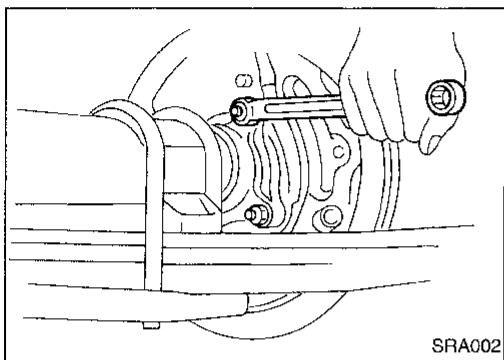

3. Draw out axle shaft with Tool.

When drawing out axle shaft, be careful not to damage oil seal.

4. Remove case shim and case seal.
— 2WD —
5. Remove O-ring. — 4WD models —
6. Remove oil seal.

Do not reuse oil seal once it is removed. Always install new one.

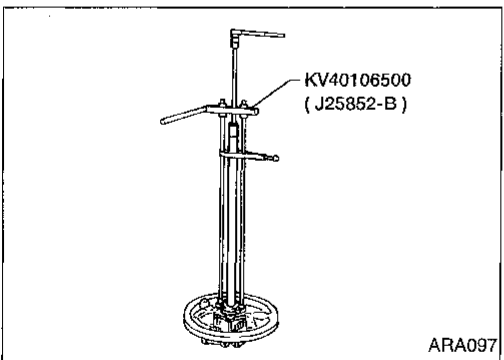

7. Remove ABS sensor rotor. — 4WD models —

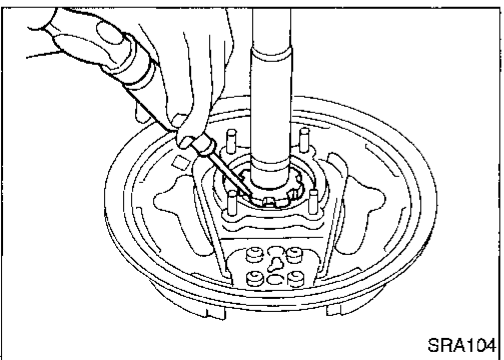

8. Unbend lock washer with a screwdriver.

REAR AXLE

Removal (Cont'd)

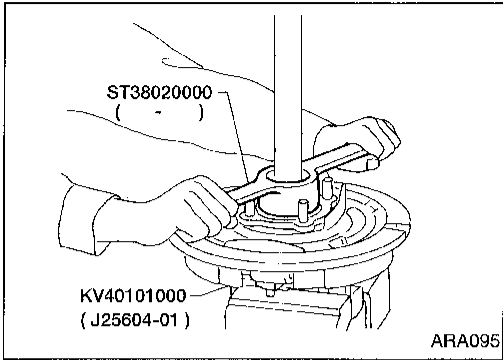

9. Remove bearing lock nut with Tool.

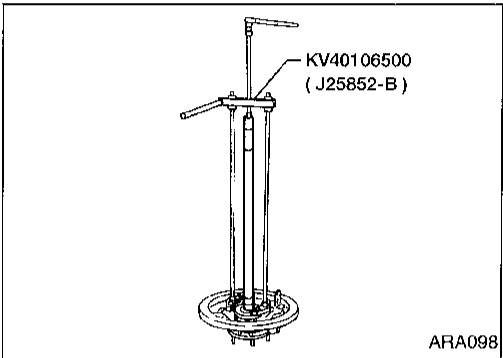

10. Remove wheel bearing together with bearing cage and baffle plate from axle shaft.

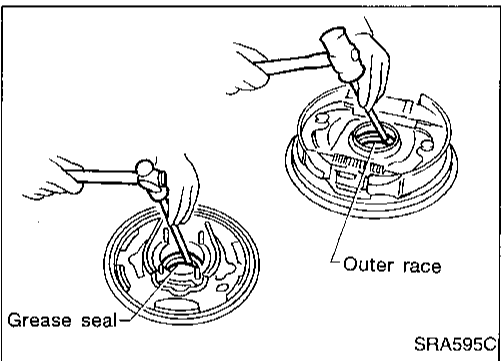

11. Remove grease seal in bearing cage with suitable bar.
12. Remove wheel bearing outer race with a brass drift.
— 2WD models —

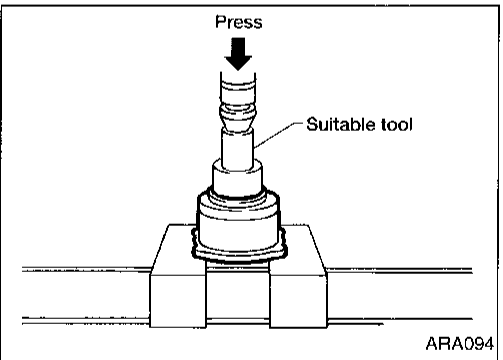

13. Remove wheel bearing assembly. — 4WD models —

GI
MA
EM
LC
EC
FE
CL
MT
AT
TF
PD
FA
RA
BR
ST
RS
BT
HA
EL
IDX

REAR AXLE

Inspection

AXLE SHAFT

- Check axle shaft for straightness, cracks, damage, wear and distortion. Replace if necessary.

WHEEL BEARING

- Make sure wheel bearing rolls freely and is free from noise, cracks, pitting and wear.

AXLE CASE

- Check axle case for yield, deformation and cracks. Replace if necessary.

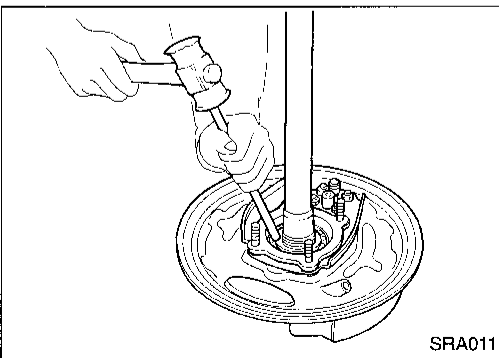
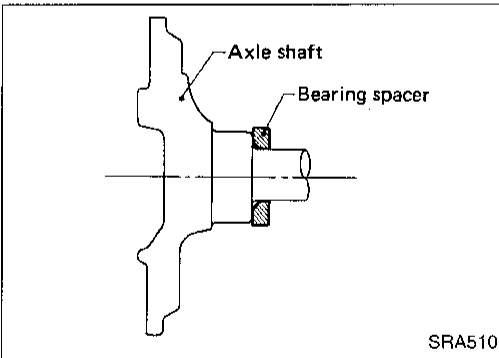
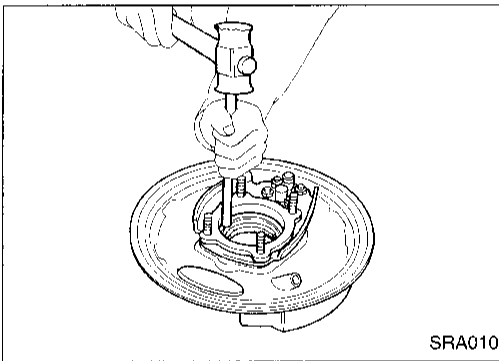

Installation — 2WD models —

1. Install wheel bearing outer race with a brass drift.
2. Install a new grease seal in bearing cage.

After installing new grease seal, coat sealing lip with multi-purpose grease.

3. Install bearing spacer with chamfer side facing axle shaft flange.

4. Install wheel bearing inner race with a brass drift.
5. Coat each bearing cone with multi-purpose grease.

Specified amount of grease:

8 - 12 g (0.28 - 0.42 oz)

REAR AXLE

Installation — 2WD models — (Cont'd)

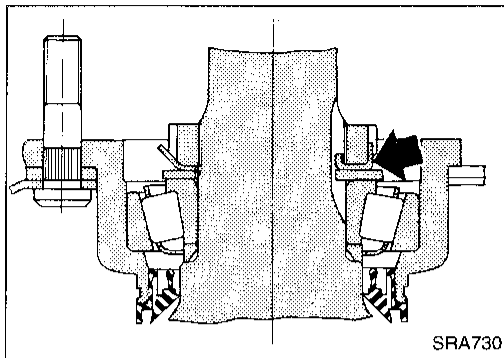

6. Install plain washer and a new wheel bearing lock washer.

7. Tighten wheel bearing lock nut.

Fit wheel bearing lock washer lip in wheel bearing lock nut groove correctly by tightening lock nut. Be sure to bend it up.

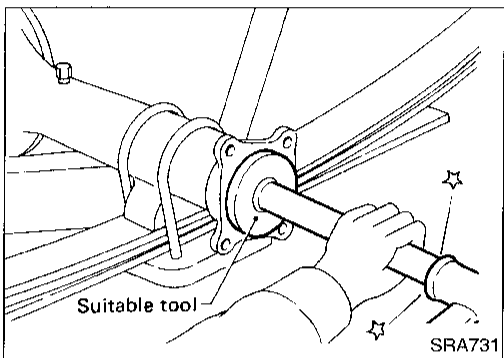

8. Install a new oil seal with suitable tool.

After installing new oil seal, coat sealing lip with multi-purpose grease.

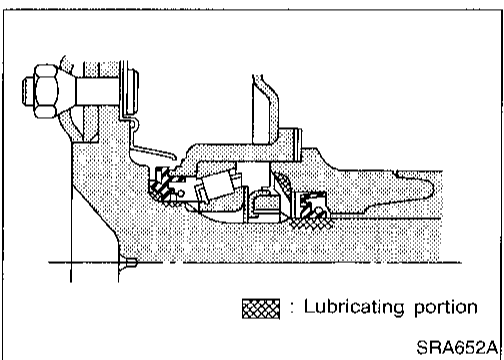

9. Apply recess of axle case end with multi-purpose grease.

10. Apply gear oil to the spline of axle shaft. Coat seal surface of axle shaft with multi-purpose grease (as shown left).

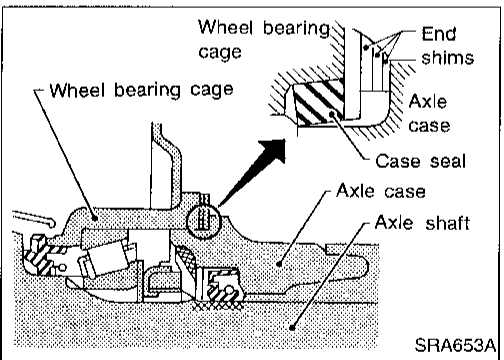

11. Adjust axial end play.

a. Select end shims.

Standard thickness including seal: 1.5 mm (0.059 in)

Axle case end shim: Refer to SDS, RA-17.

Do not insert end shims between case seal and bearing cage.

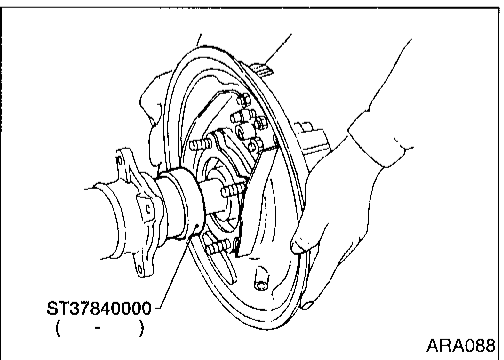

b. Insert axle shaft with Tool as a guide.

When inserting axle shaft, be careful not to damage oil seal.

c. Measure end play of axle shaft.

Axial end play:

Servicing only one side of axle shaft

0.02 - 0.15 mm (0.0008 - 0.0059 in)

Servicing both side axle shafts

On first axle shaft (right or left) adjust axial end play

0.30 - 0.90 mm (0.0118 - 0.0354 in)

After servicing second axle shaft, total end play

0.02 - 0.15 mm (0.0008 - 0.0059 in)

GI

MA

EM

LC

EC

FE

CL

MT

AT

TF

PD

FA

RA

BR

ST

RS

BT

HA

EL

IDX

REAR AXLE

Installation — 2WD models — (Cont'd)

d. If axial end play is not within the specified limit, reselect axle case end shims.

While adjusting axial end play, be careful not to damage oil seal.

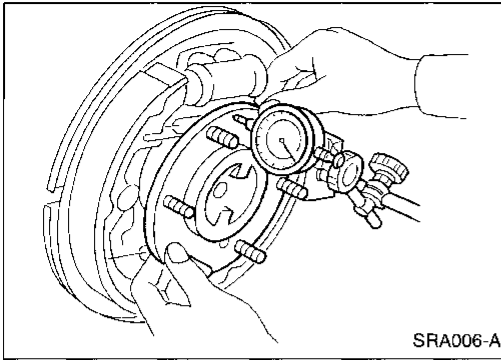

Installation — 4WD models —

1. Press new wheel bearing until it bottoms end face of bearing cage.

Maximum load P:

78 kN (8 ton, 8.8 US ton, 7.9 Imp ton)

Always press outer race of wheel bearing during installation.

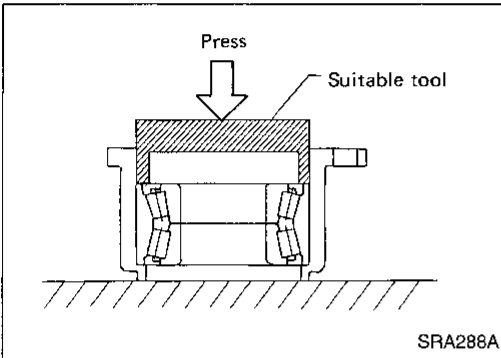

2. Press new grease seal until it bottoms end face of bearing cage.

After installing new grease seal, coat sealing lip with multi-purpose grease.

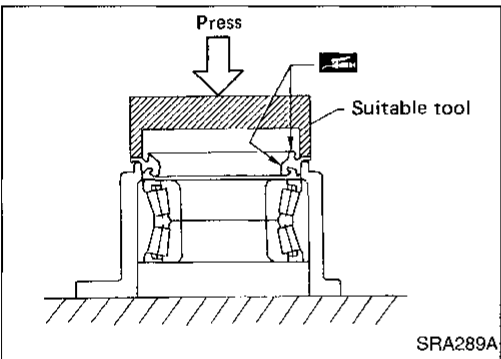

3. Press axle shaft into inner race of wheel bearing.

Maximum load P:

47.1 kN (4.8 ton, 5.3 US ton, 4.72 Imp ton)

Be careful not to damage or deform grease seal.

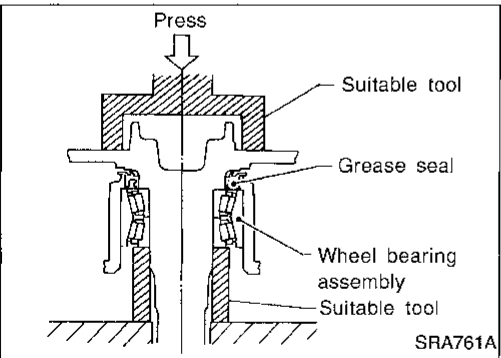

4. Install plain washer and a new wheel bearing lock washer.

5. Tighten wheel bearing lock nut to specified torque.

☐: 245 - 294 N·m (25 - 30 kg·m, 181 - 217 ft·lb)

Fit wheel bearing lock washer lip in wheel bearing lock nut groove correctly by tightening lock nut. Be sure to bend it up.

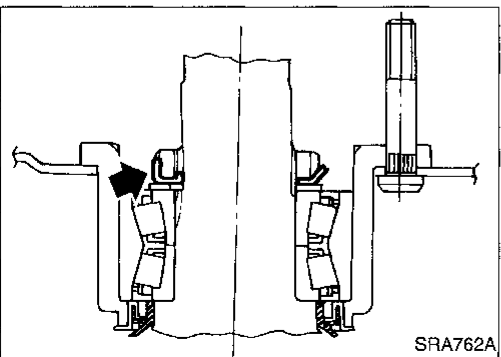

REAR AXLE

Installation — 4WD models — (Cont'd)

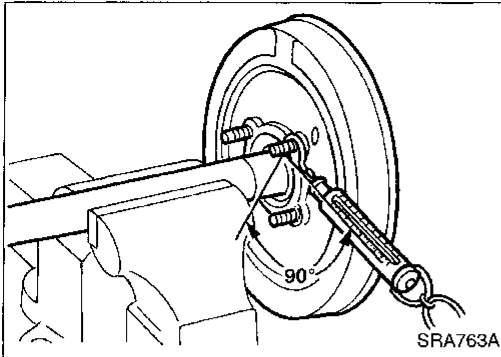

6. Check wheel bearing preload.
 - a. Turn bearing cage (with respect to axle shaft) two or three times. It must turn smoothly.
 - b. Attach spring gauge to bearing cage bolt (as shown at left) and pull it at a speed of 10 rpm to measure preload.

Spring gauge indication:

6.9 - 48.1 N (0.7 - 4.9 kg, 1.5 - 10.8 lb)

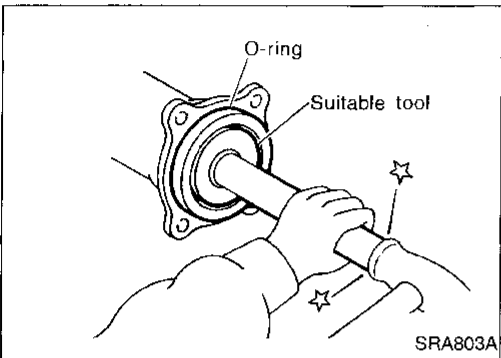

7. Install new oil seal to rear axle housing using a suitable tool. **After installing new oil seal, coat sealing lip with multi-purpose grease.**

8. Install new O-ring to rear axle housing.

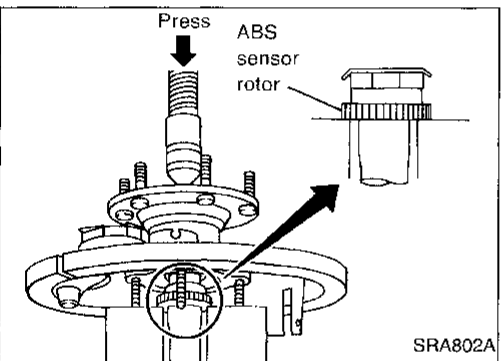

9. Press ABS sensor rotor onto axle shaft until it contacts wheel bearing lock nut.

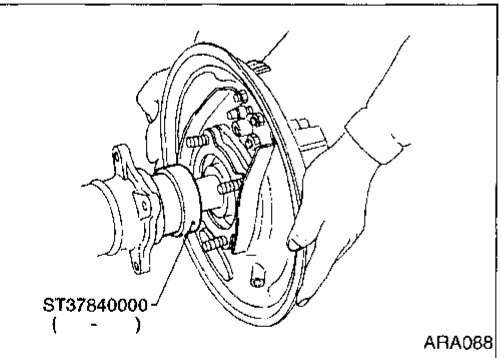

10. Position axle shafts in rear axle housing with Tool as a guide. **Be careful not to damage oil seal.**

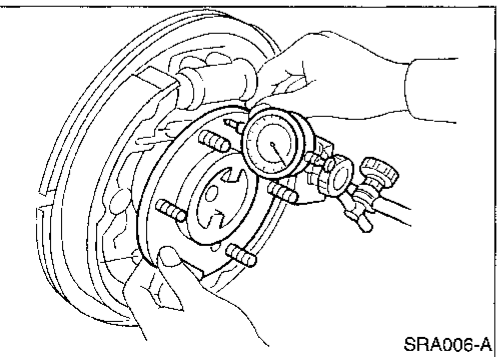

11. Check axial end play.
 - a. Check that wheel bearings operate smoothly.
 - b. Check axial end play.

Axial end play:

0 mm (0 in)

GI

MA

EM

LC

EC

FE

CL

MT

AT

TF

PD

FA

RA

BR

ST

RS

BT

HA

EL

IDX

REAR SUSPENSION

2WD models

SEC. 431

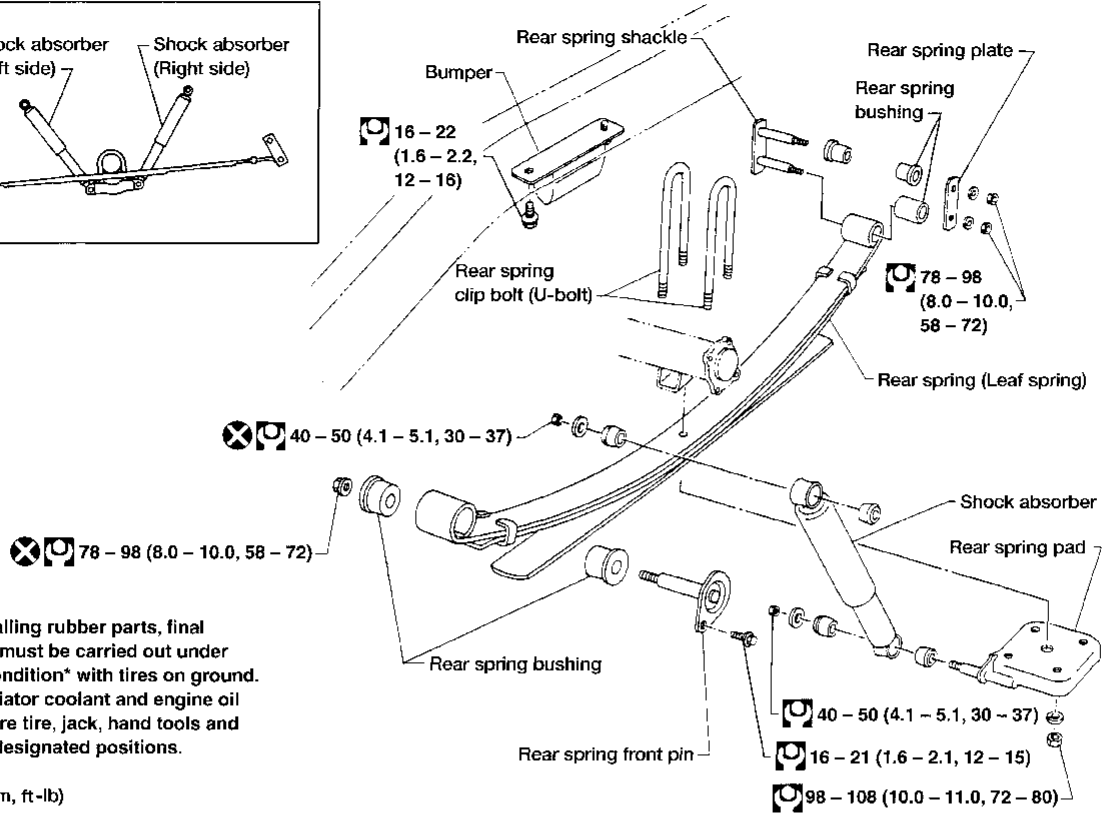
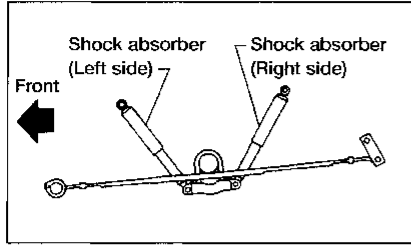

When installing rubber parts, final tightening must be carried out under unladen condition* with tires on ground.
 * Fuel, radiator coolant and engine oil full. Spare tire, jack, hand tools and mats in designated positions.

: N·m (kg-m, ft-lb)

ARA092

4WD models

SEC. 431

Bumper
 * Make sure of front mark.

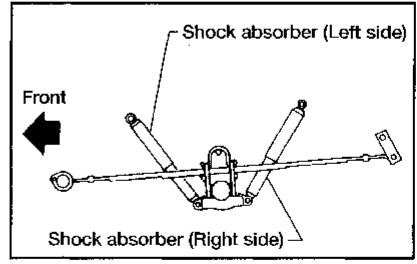
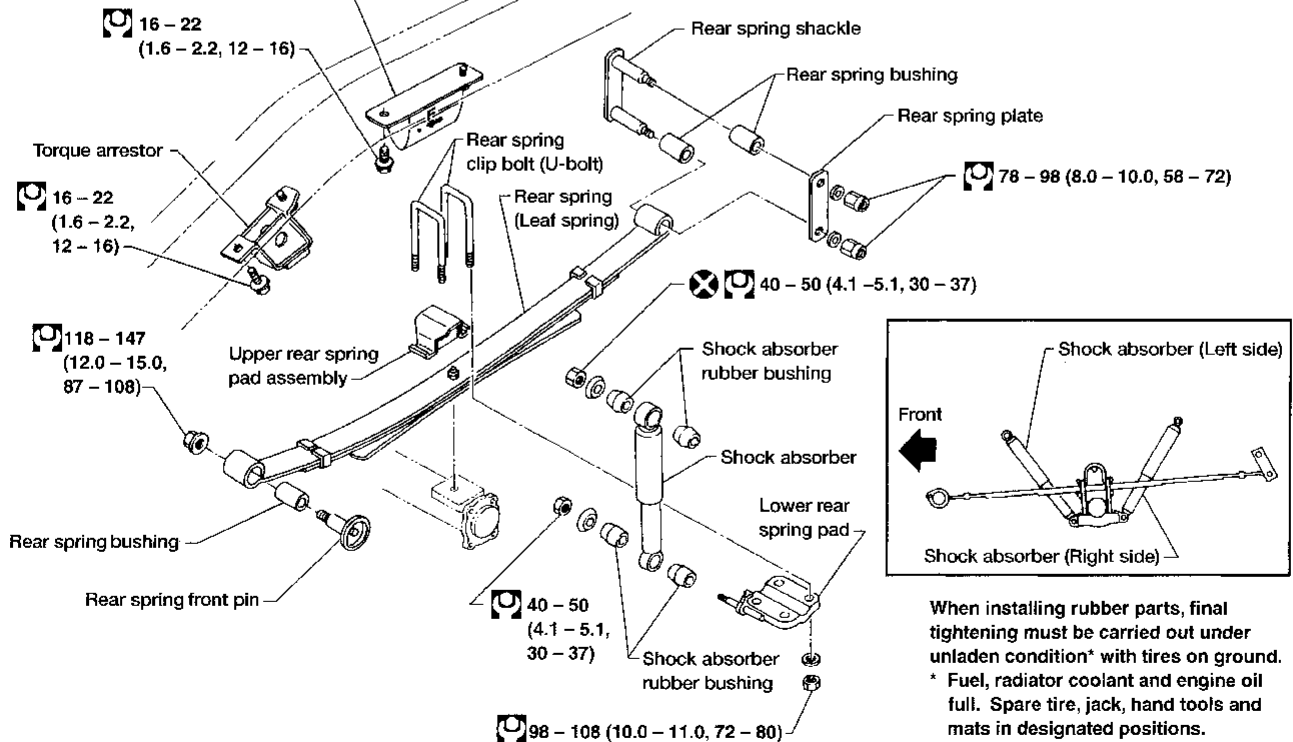

When installing rubber parts, final tightening must be carried out under unladen condition* with tires on ground.
 * Fuel, radiator coolant and engine oil full. Spare tire, jack, hand tools and mats in designated positions.

: N·m (kg-m, ft-lb)

ARA093

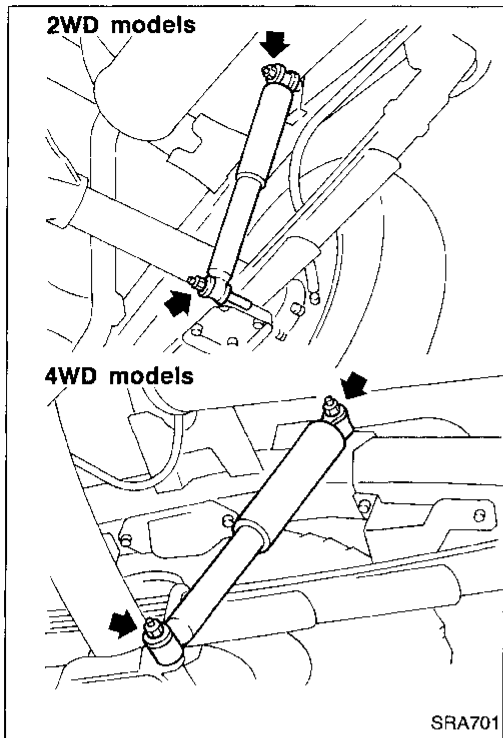

Shock Absorber

REMOVAL AND INSTALLATION

- Remove shock absorber by disconnecting upper and lower end.

INSPECTION

- If oil leakage, cracks and deformation occurs, replace shock absorber assembly.
- If rubber bushings are cracked and deformed, replace rubber bushings.

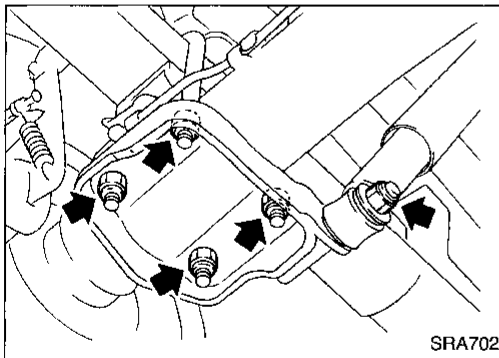

Leaf Spring

REMOVAL AND INSTALLATION

1. Disconnect shock absorber lower end, and remove U-bolts.

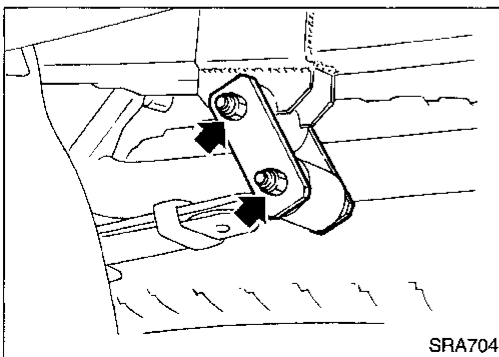

2. Disconnect spring shackle.

GI

MA

EM

LC

EC

FE

CL

MT

AT

TF

PD

FA

RA

BR

ST

RS

BT

HA

EL

IDX

REAR SUSPENSION

Leaf Spring (Cont'd)

3. Disconnect front pin.

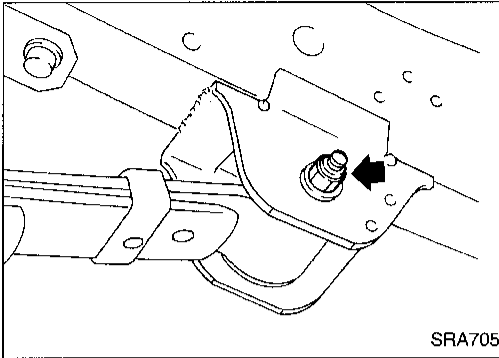

4WD models

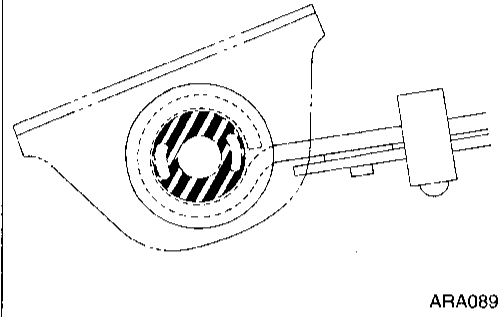

INSPECTION

- Check leaf spring for cracks. Replace if necessary.
- Check front bracket and pin, shackle, U-bolts and spring pad for wear, cracks, straightness and damaged threads. Replace if necessary.
- Check all bushings for deformation and cracks. Replace if necessary.
(4WD models: Rear spring front bushing)
Make sure that front bushing is properly installed.

INSTALLATION

1. Apply soapsuds to rubber bushing.
2. Install spring shackle and front pin, and finger tighten the nuts.
3. Install spring pad and nuts under leaf spring or axle case.
4. Tighten U-bolt mounting nuts diagonally.

Tighten U-bolts so that the lengths of all U-bolts under spring pad are the same.

5. Install shock absorber, and finger tighten the nuts.

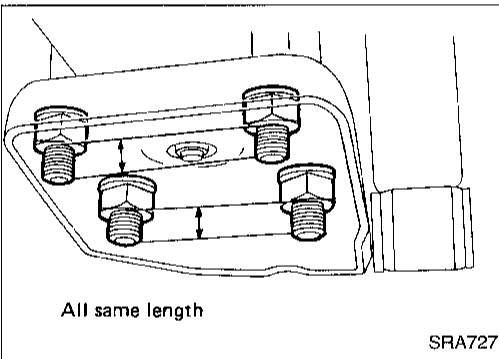

6. Remove stands and bounce the vehicle to stabilize suspension. (Unladen)

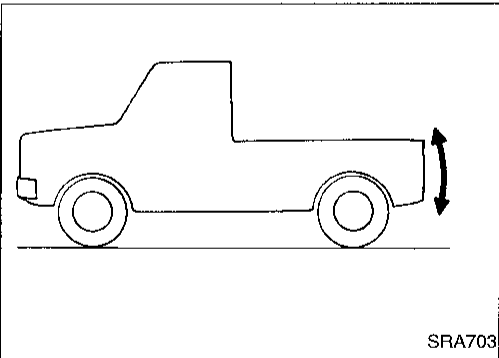

7. Tighten spring shackle nuts, front pin nuts and shock absorber nuts.

When installing rubber parts, final tightening must be carried out under unladen condition* with tires on the ground.

* Fuel, radiator coolant and engine oil full. Spare tire, jack, hand tools and mats in designated positions.

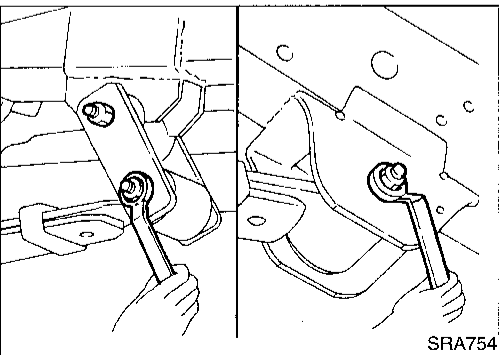

SERVICE DATA AND SPECIFICATIONS (SDS)

General Specifications

Suspension type	Rigid axle with semi-elliptic leaf spring
Shock absorber type	Double-acting hydraulic

Inspection and Adjustment

WHEEL BEARING — 2WD models —

Total end play	mm (in)	0.02 - 0.15 (0.0008 - 0.0059)	
Available rear axle case end shims	Thickness	Part number	
		mm (in)	
		0.05 (0.0020)	43086-P0110
		0.07 (0.0028)	43087-P0110
		0.10 (0.0039)	43088-P0110
		0.15 (0.0059)	43086-B9500
		0.20 (0.0079)	43089-P0110
	0.50 (0.0197)	43090-P0110	
	1.00 (0.0394)	43036-01G00	

WHEEL BEARING — 4WD models —

Total end play	mm (in)	0 (0)
Wheel bearing preload at bearing cage bolt	N (kg, lb)	6.9 - 48.1 (0.7 - 4.9, 1.5 - 10.8)

GI

MA

EM

LC

EC

FE

CL

MT

AT

TF

PD

FA

RA

BR

ST

RS

BT

HA

EL

IDX