

SECTION **MT**

**CONTENTS**

<b>PREPARATION</b> .....	2	<b>DISASSEMBLY</b> .....	15
Special Service Tools .....	2	Case Components .....	15
Commercial Service Tools .....	3	Shift Control Components .....	15
<b>NOISE, VIBRATION AND HARSHNESS (NVH)</b>		Gear Components .....	16
<b>TROUBLESHOOTING</b> .....	4	<b>INSPECTION</b> .....	19
NVH Troubleshooting Chart.....	4	Shift Control Components .....	19
<b>DESCRIPTION</b> .....	5	Gear Components .....	19
Cross-sectional View — 2WD Model — .....	5	Gears And Shafts.....	19
Cross-sectional View — 4WD Model — .....	6	Synchronizers.....	19
<b>ON-VEHICLE SERVICE</b> .....	7	Bearings .....	20
Replacing Rear Oil Seal — 2WD Model — .....	7	<b>ASSEMBLY</b> .....	21
Position Switch Check .....	7	Gear Components .....	21
<b>REMOVAL AND INSTALLATION</b> .....	8	Shift Control Components .....	27
<b>MAJOR OVERHAUL</b> .....	11	Case Components .....	28
Case Components.....	11	<b>SERVICE DATA AND SPECIFICATIONS (SDS)</b> .....	31
Gear Components — 2WD Model —.....	12	General Specifications.....	31
Gear Components — 4WD Model —.....	13	Inspection and Adjustment .....	32
Shift Control Components .....	14		

# PREPARATION

## Special Service Tools

The actual shapes of Kent-Moore tools may differ from those of special service tools illustrated here.

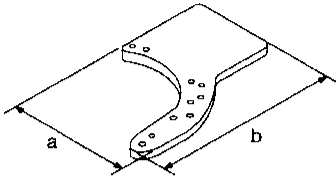
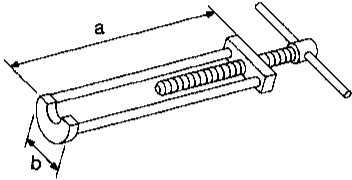
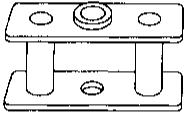
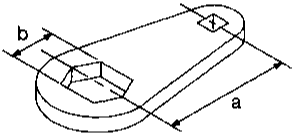
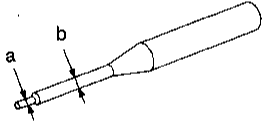
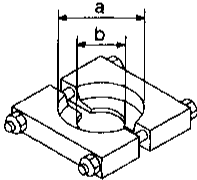
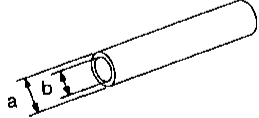
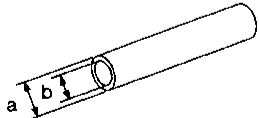
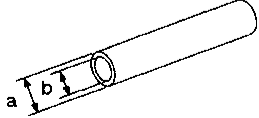
Tool number (Kent-Moore No.) Tool name	Description
ST23810001 ( — ) Adapter setting plate	Fixing adapter plate with gear assembly  NT407 a: 166 mm (6.54 in) b: 270 mm (10.63 in)
KV32101330 (See J26349-A) Puller	Removing overdrive mainshaft bearing  NT408 a: 447 mm (17.60 in) b: 100 mm (3.94 in)
KV31100401 ( — ) Transmission press stand	Pressing counter gear and mainshaft  NT068
ST22520000 (J26348) Wrench	Tightening mainshaft lock nut  NT409 a: 100 mm (3.94 in) b: 41 mm (1.61 in)
ST23540000 (J25689-A) Pin punch	Removing and installing fork rod retaining pin  NT442 a: 2.3 mm (0.091 in) dia. b: 4 mm (0.16 in) dia.
ST30031000 (J22912-01) Puller	Removing and installing 1st gear bushing Removing main drive gear bearing  NT411 a: 90 mm (3.54 in) dia. b: 50 mm (1.97 in) dia.
ST23860000 ( — ) Drift	Installing counter drive gear  NT065 a: 38 mm (1.50 in) dia. b: 33 mm (1.30 in) dia.
ST22360002 (J25679-01) Drift	Installing counter gear front and rear end bearings  NT065 a: 29 mm (1.14 in) dia. b: 23 mm (0.91 in) dia.
ST22350000 (J25678-01) Drift	Installing OD gear bushing  NT065 a: 34 mm (1.34 in) dia. b: 28 mm (1.10 in) dia.

# PREPARATION

## Special Service Tools (Cont'd)

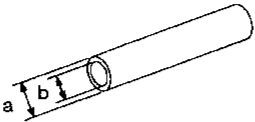
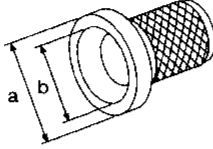
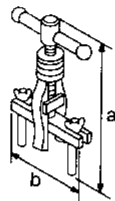
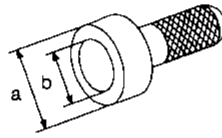
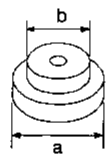
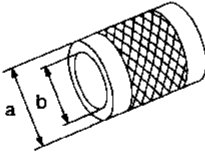
Tool number (Kent-Moore No.) Tool name	Description	
ST23800000 (J25691-01) Drift	 NT065	Installing front cover oil seal  <b>a: 44 mm (1.73 in) dia.</b> <b>b: 31 mm (1.22 in) dia.</b>
ST33400001 (J26082) Drift	 NT086	Installing rear oil seal  <b>a: 60 mm (2.36 in) dia.</b> <b>b: 47 mm (1.85 in) dia.</b>
ST33290001 (J34286) Puller	 NT414	Removing rear oil seal  <b>a: 250 mm (9.84 in)</b> <b>b: 160 mm (6.30 in)</b>
ST30720000 (J25405) Drift	 NT115	Installing mainshaft ball bearing  <b>a: 77 mm (3.03 in) dia.</b> <b>b: 55.5 mm (2.185 in) dia.</b>
ST30613000 (J25742-3) Drift	 NT073	Installing main drive gear bearing  <b>a: 71.5 mm (2.815 in) dia.</b> <b>b: 47.5 mm (1.870 in) dia.</b>
ST33200000 (J26082) Drift	 NT091	Installing counter rear bearing  <b>a: 60 mm (2.36 in) dia.</b> <b>b: 44.5 mm (1.752 in) dia.</b>

## Commercial Service Tools

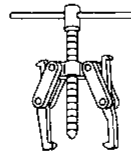
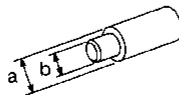
Tool name	Description	
Puller	 NT077	Removing counter bearings, counter drive and OD gears  BT  HA
Drift	 NT074	Installing countershaft rear end bearing (FS5W71C-4WD model)  <b>a: 40 mm (1.57 in) dia.</b> <b>b: 30 mm (1.18 in) dia.</b>  EL  IDX

## NVH Troubleshooting Chart

Use the chart below to help you find the cause of the symptom. The numbers indicate the order of the inspection. If necessary, repair or replace these parts.

### MANUAL TRANSMISSION

Reference page		Refer to MA section ("Checking M/T Oil", CHASSIS AND BODY MAIN- TENANCE").										
Possible cause and SUSPECTED PARTS												
		OIL (Oil level is low.)	OIL (Wrong oil.)	OIL (Oil level is high.)	GASKET (Damaged)	OIL SEAL (Worn or damaged)	CHECK PLUG RETURN SPRING AND CHECK BALL (Worn or damaged)	SHIFT FORK (Worn)	GEAR (Worn or damaged)	BEARING (Worn or damaged)	BAULK RING (Worn or damaged)	INSERT SPRING (Damaged)
Symptom	Noise	1	2						3	3		
	Oil leakage		3	1	2	2						
	Hard to shift or will not shift		1	1							2	2
	Jumps out of gear						1	2	2			



# DESCRIPTION

## Cross-sectional View — 4WD Model —

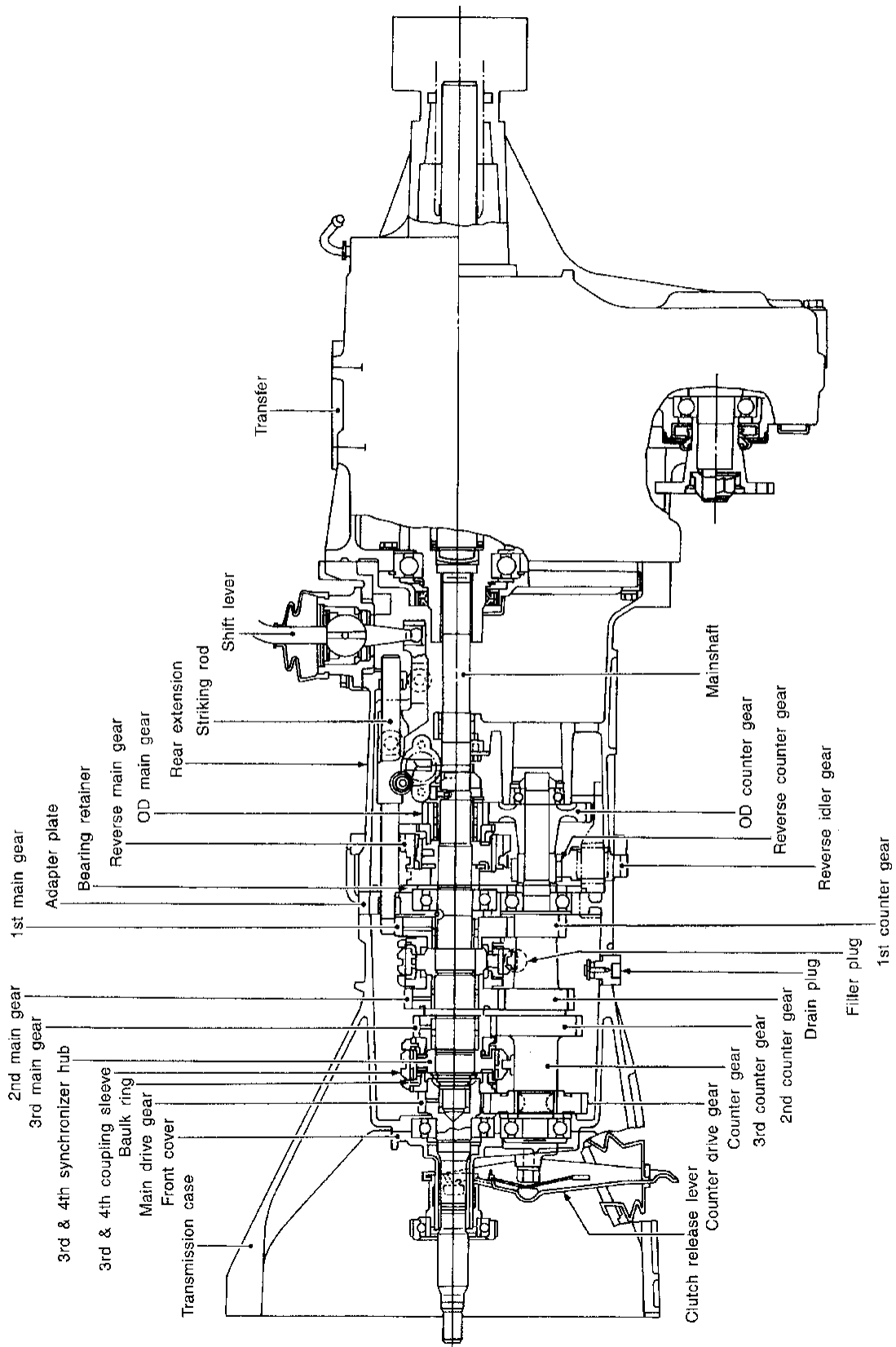



# REMOVAL AND INSTALLATION

## Removal

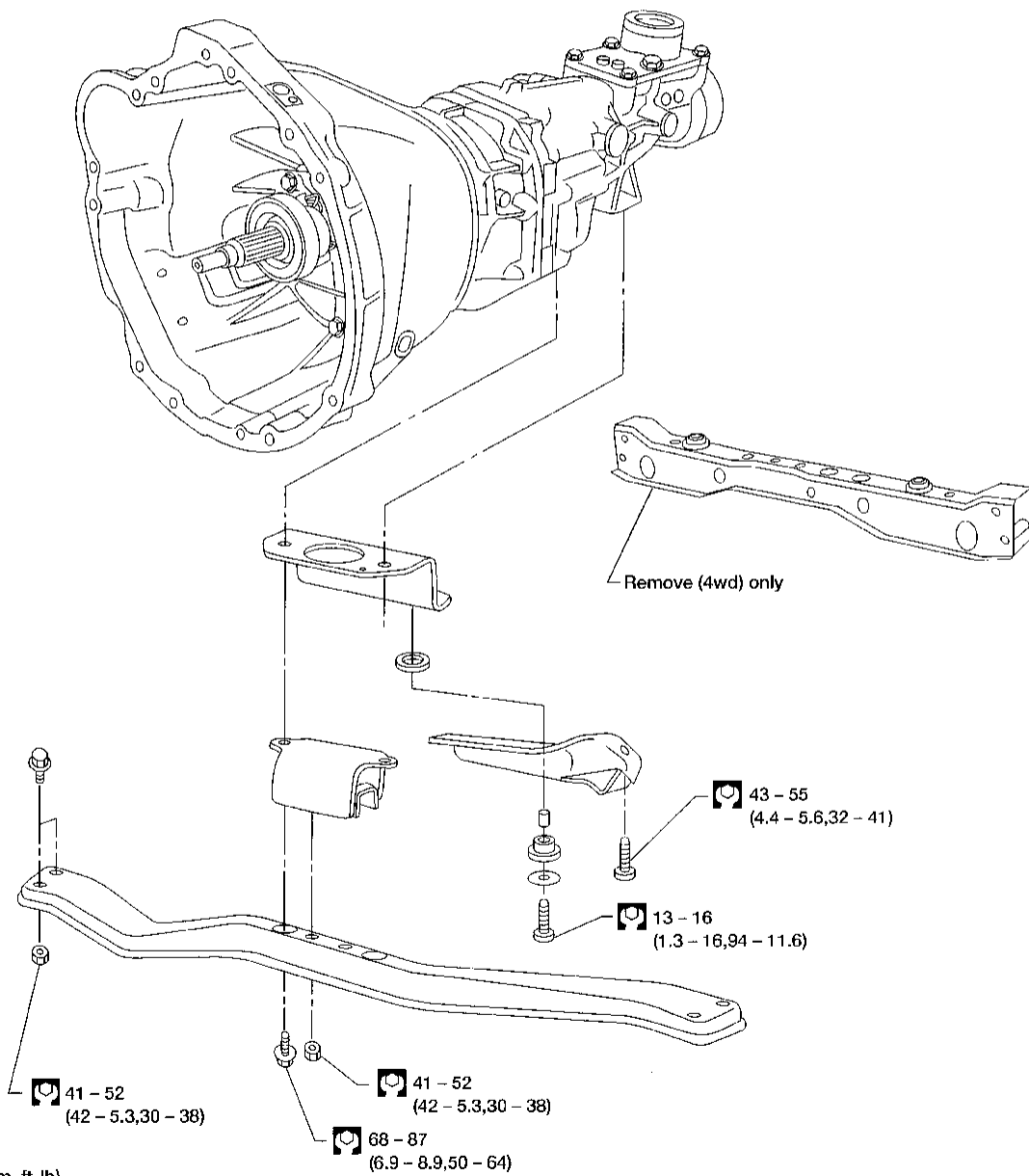
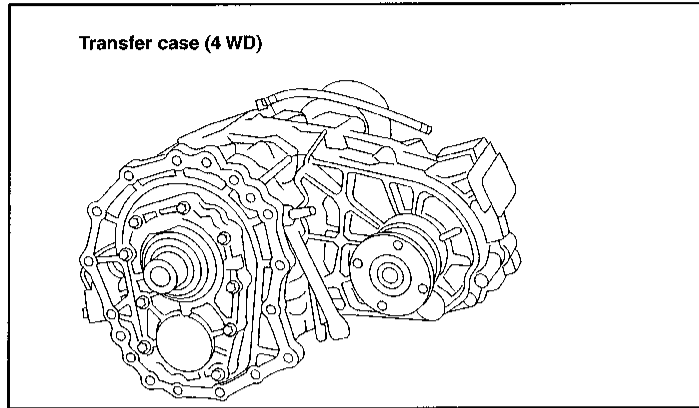



# REMOVAL AND INSTALLATION

## Removal (Cont'd)

### CAUTION:

Before separating the transmission from the engine, remove the crankshaft position sensor (OBD) from the transmission. Be careful not to damage sensor edge or ring gear teeth.

### 2WD MODEL

**NOTE:** To prevent oil spills, drain transmission oil before removing transmission or insert plug into rear oil seal after removing propeller shaft.

- Be careful not to damage spline, sleeve yoke and rear oil seal when removing propeller shaft.

1. Remove battery negative terminal.
2. Remove crankshaft position sensor (OBD) from transmission upper side.
3. Remove clutch operating cylinder from transmission.
4. Remove back-up switch and neutral position switch harness connectors.
5. Remove starter motor from transmission.
6. Remove propeller shaft. Refer to PD section ("Removal and Installation", "PROPELLER SHAFT").

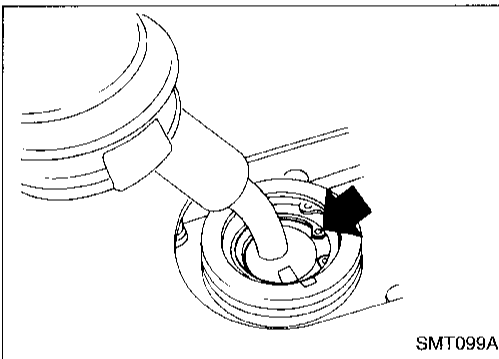

7. Remove shift lever.
8. Support engine by placing a jack under oil pan.
- Do not place jack under oil pan drain plug.
9. Separate transmission from engine.

### WARNING:

Support manual transmission while removing it.

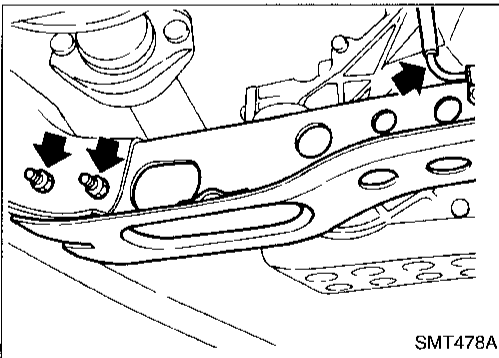

### 4WD MODEL

**NOTE:** To prevent oil spills, drain transmission and transfer oil before removing transmission or insert plug into rear oil seal of transfer after removing propeller shafts.

- Always drain transmission and transfer oil whenever separating transmission and transfer.

1. Remove battery negative terminal.
2. Remove crankshaft position sensor (OBD) from transmission upper side.
3. Remove clutch operating cylinder from transmission.
4. Remove back-up switch and neutral position switch harness connector.
5. Remove starter motor from transmission.
6. Remove front and rear propeller shafts. Refer to PD section ("Removal and Installation", "PROPELLER SHAFT").
- Be careful not to damage splines, sleeve yokes and front and rear oil seals of transfer when removing propeller shafts.
7. Remove torsion bar springs. Refer to FA section ("Torsion Bar Spring", "FRONT SUSPENSION"). Then remove second crossmember.

GI

MA

EM

LC

EC

FE

CL

MT

AT

TF

PD

FA

RA

BR

ST

RS

BT

HA

EL

IDX

# REMOVAL AND INSTALLATION

## Removal (Cont'd)

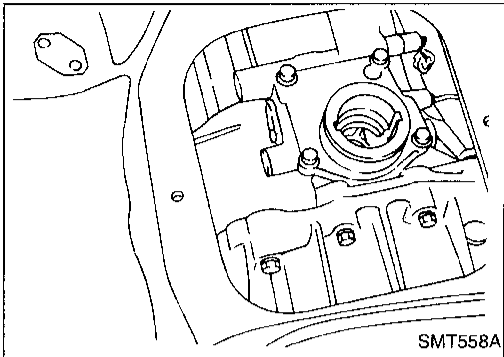

8. Remove transmission shift lever and transfer control lever.
9. Support engine by placing a jack under oil pan.
  - **Do not place jack under oil pan drain plug.**
10. Support transmission with a jack and remove engine rear member.
11. For clutch disc replacement, separate transmission with transfer from engine. For transmission overhaul, remove transfer from transmission, then separate transmission from engine.

### WARNING:

**Support manual transmission with transfer while removing it.**

## Installation

1. Apply sealant to areas shown below, — 4WD model.

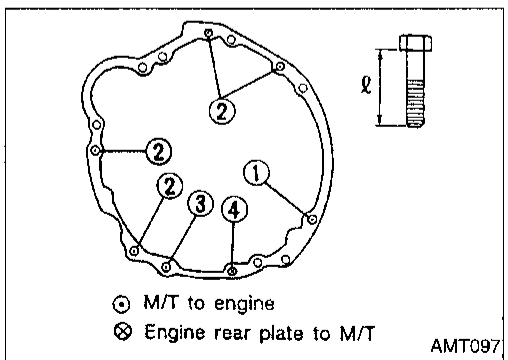
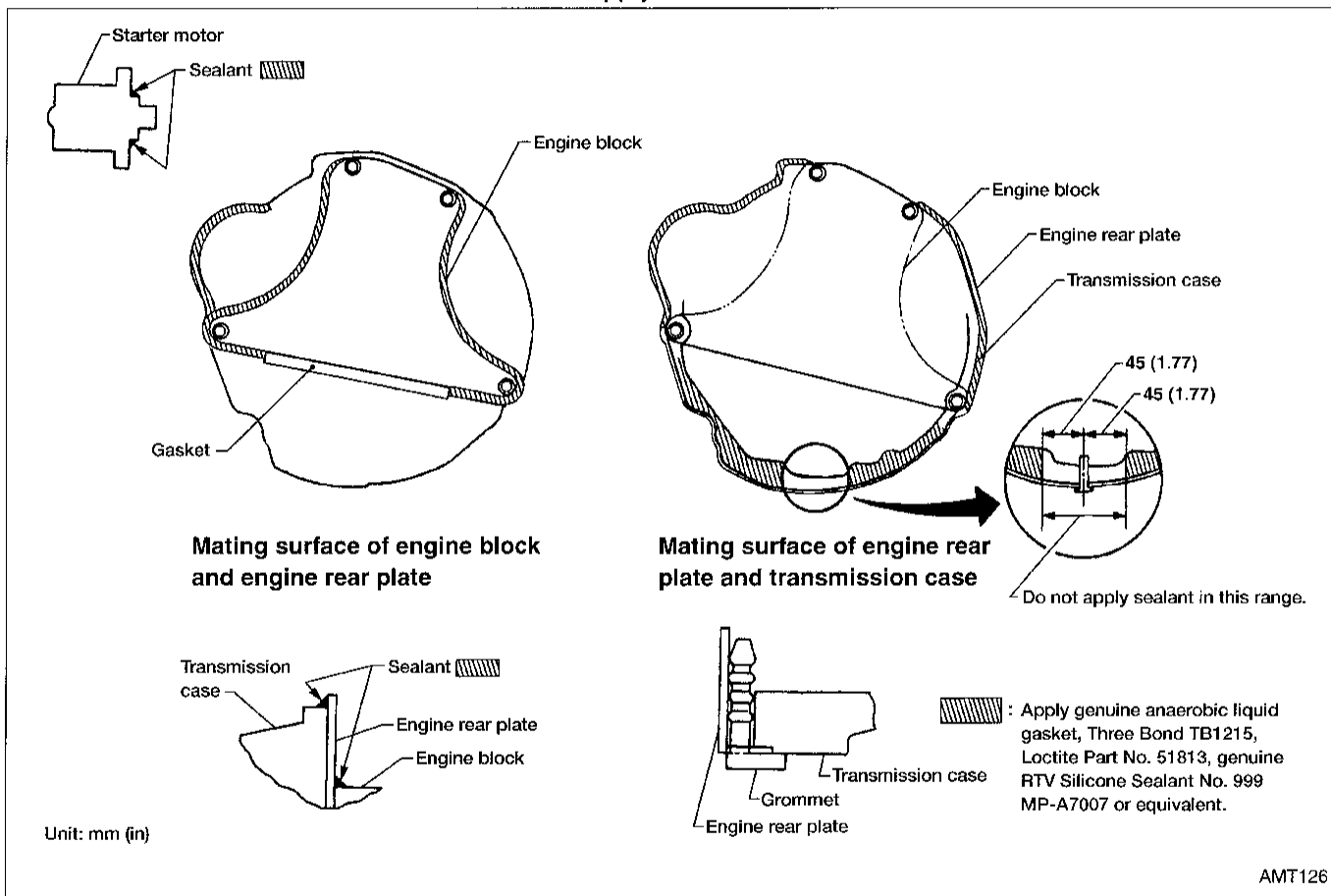

2. Tighten bolts securing transmission.

Bolt No.	Tightening torque N·m (kg·m, ft·lb)	ℓ mm (in)
①	39 - 49 (4.0 - 5.0, 29 - 36)	65 (2.56)
②	39 - 49 (4.0 - 5.0, 29 - 36)	58 (2.28)
③*	16 - 22 (1.6 - 2.2, 12 - 16)	25 (0.98)
④	16 - 22 (1.6 - 2.2, 12 - 16)	16 (0.63)

\*: With nut

3. Tighten clutch operating cylinder to the specified torque. Refer to CL section ("CLUTCH SYSTEM").
4. For transfer installation, refer to TF section ("Installation", "REMOVAL AND INSTALLATION").

## Case Components

SEC. 320 • 321

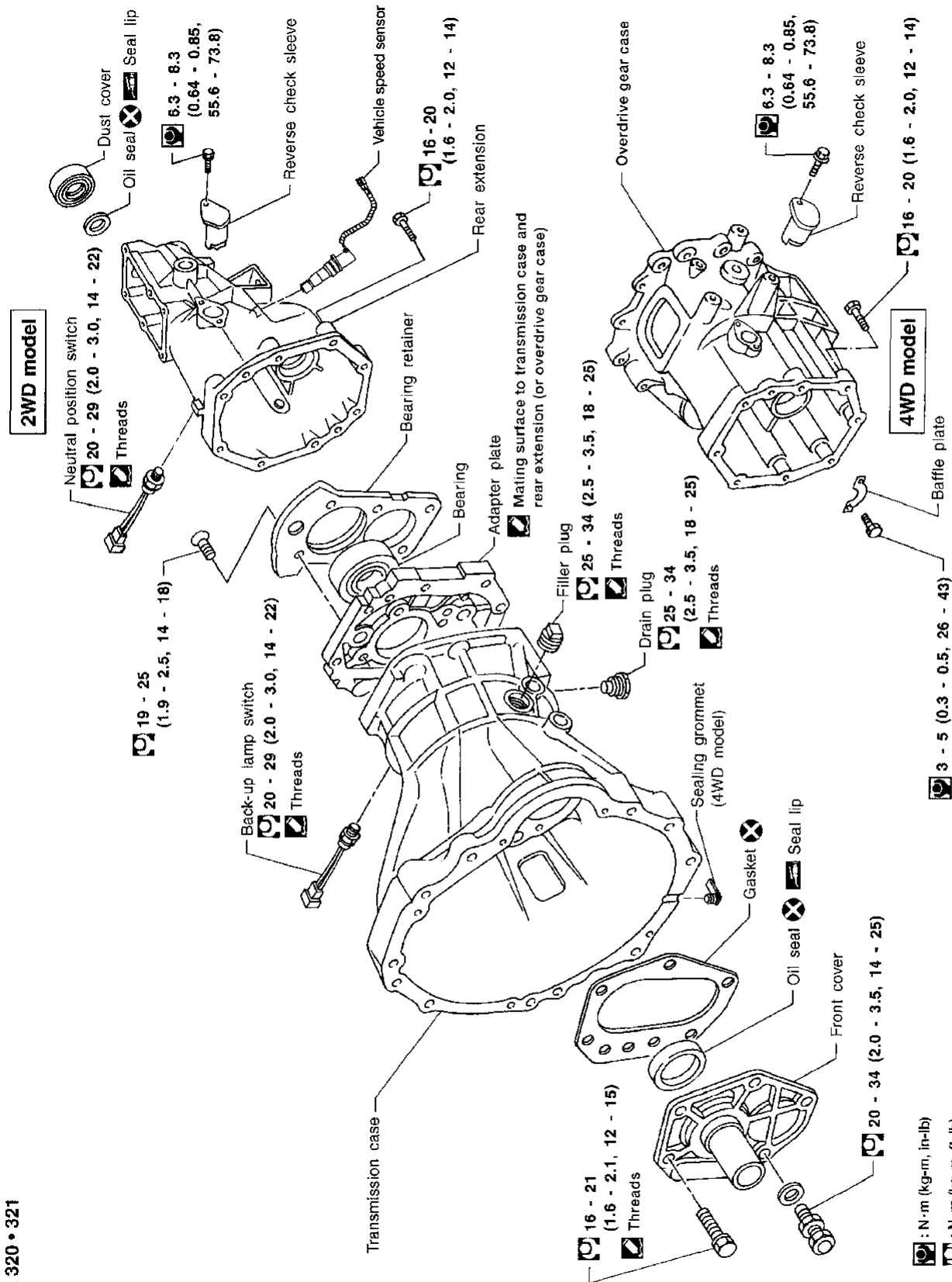

⊗ : N·m (kg-m, in-lb)

⊠ : N·m (kg-m, ft-lb)

⊞ : Apply genuine liquid gasket, Three Bond TB 1215, Loctite Part No. 51813 or equivalent.

⊞ : Should be lubricated with grease.

GI

MA

EM

LC

EC

FE

CL

**MT**

AT

TF

PD

FA

RA

BR

ST

RS

BT

HA

EL

IDX

## Gear Components — 2WD Model —

SEC. 322

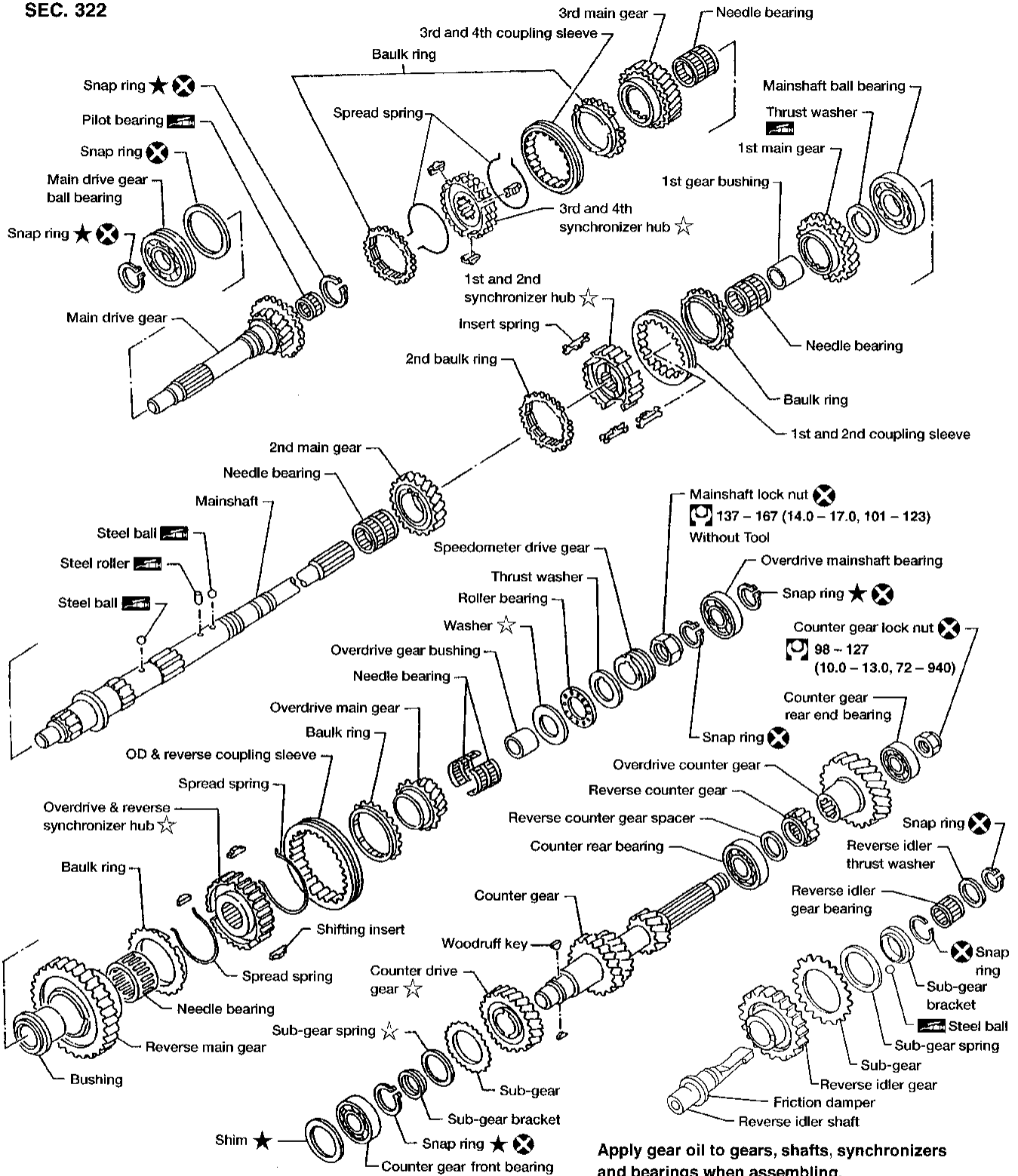

Apply gear oil to gears, shafts, synchronizers and bearings when assembling.

★ : Select proper thickness.

☆ : Pay attention to its direction.

☐ : N · m (kg-m, ft-lb)

■ : Should be lubricated with grease.

## Gear Components — 4WD Model —

GI  
MA  
EM  
LC  
EC  
FE  
CL  
**MT**  
AT  
TF  
PD  
FA  
RA  
BR  
ST  
RS  
BT  
HA  
EL  
JDX

SEC. 322

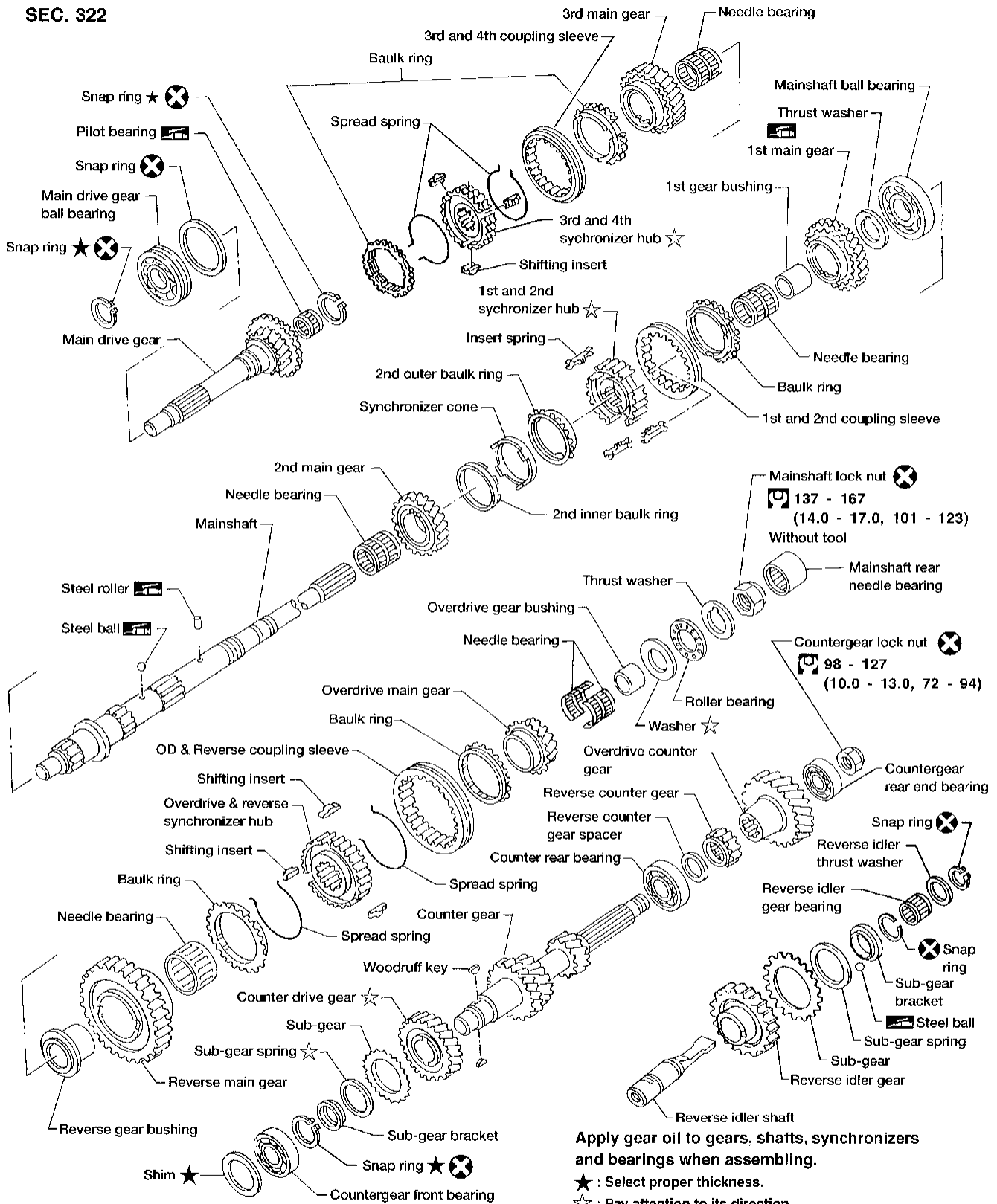

**Apply gear oil to gears, shafts, synchronizers and bearings when assembling.**  
 ★ : Select proper thickness.  
 ☆ : Pay attention to its direction.  
 [N·m symbol] : N·m (kg-m, ft-lb)  
 [Grease symbol] : Should be lubricated with grease.

Shift Control Components

CAUTION:

To avoid damage when replacing shift knob, remove shift lever with knob, as assembled.

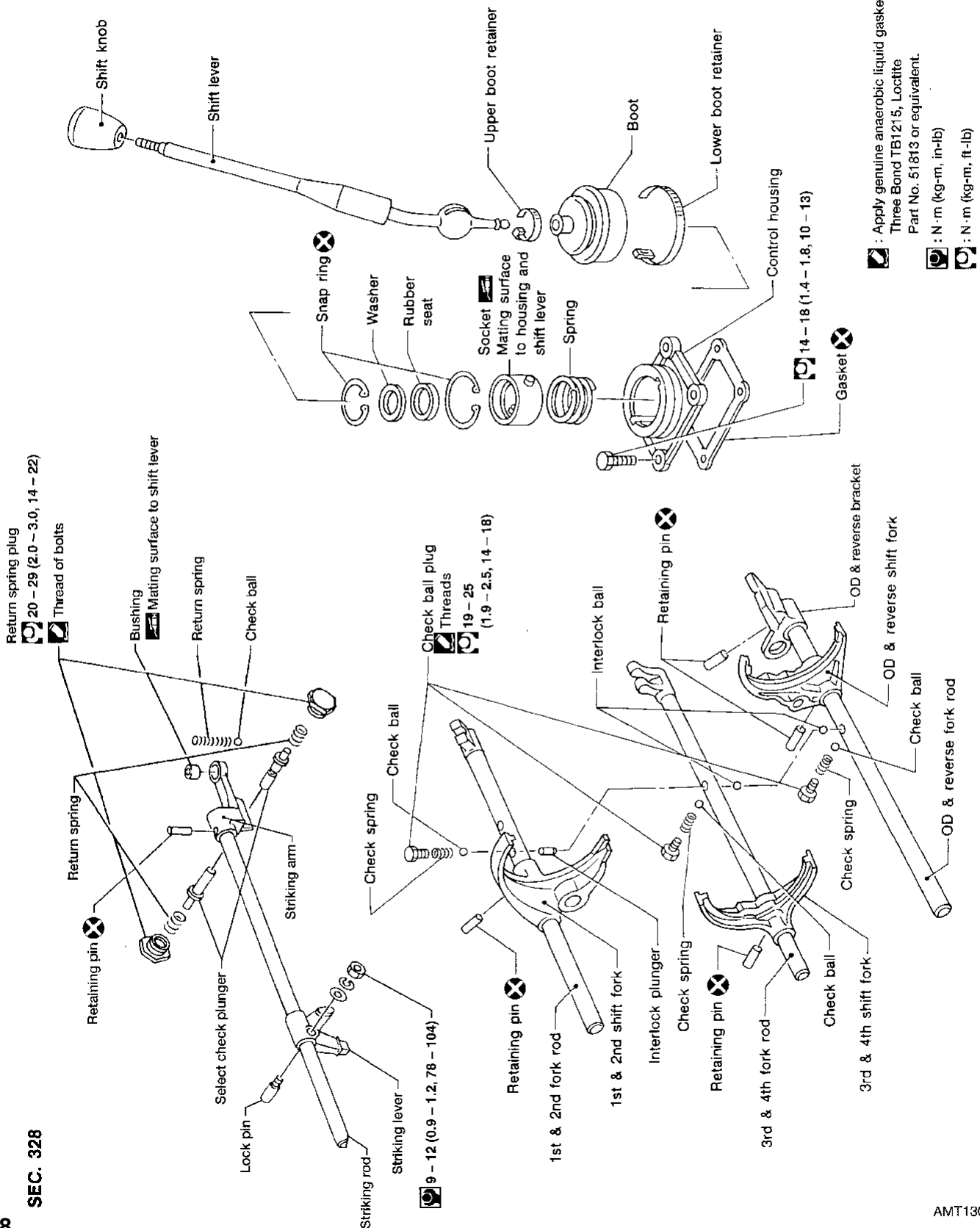

# DISASSEMBLY

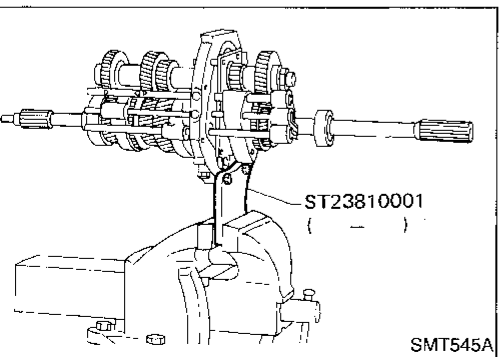
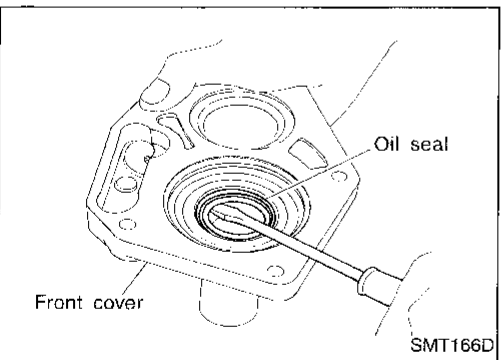
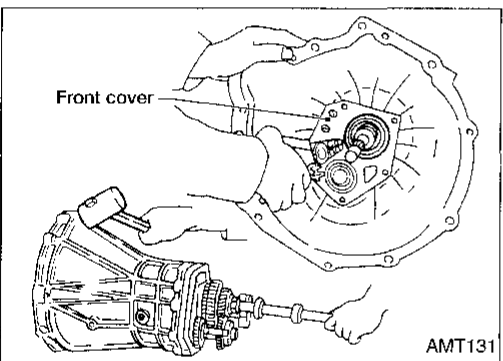
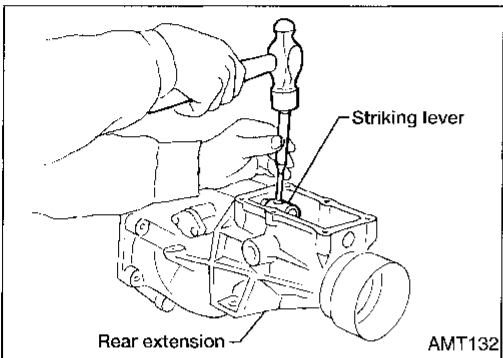
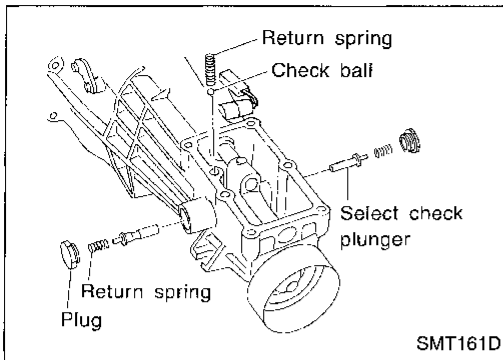

## Case Components

1. Remove rear extension.
    - a. Remove control housing, check ball, return spring plugs, select check plungers and return springs. Also remove reverse check plug, check spring and check ball.
- **Be careful not to lose check balls.**

- b. Drive out striking lever retaining pin.
- c. Remove striking lever from striking rod.
- d. Remove rear extension by lightly tapping on it.

2. Remove front cover, gasket, counter gear front bearing shim and main drive gear ball bearing snap ring.
3. Separate transmission case from adapter plate by lightly tapping on it.

4. Remove oil seal from front cover.
- **Be careful not to damage mating surface of front cover.**

## Shift Control Components

1. Set up Tool on adapter plate.
2. Remove striking rod from adapter plate.
3. Remove check ball plugs, check springs, and check balls.

GI

MA

EM

LC

EC

FE

CL

MT

AT

TF

PD

FA

RA

BR

ST

RS

BT

HA

EL

IDX

## DISASSEMBLY

### Shift Control Components (Cont'd)

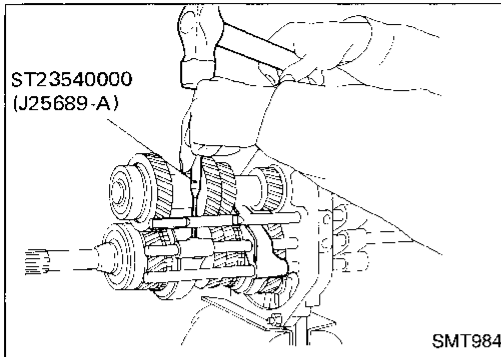

4. Drive out retaining pins. Then drive out fork rods and remove interlock balls.

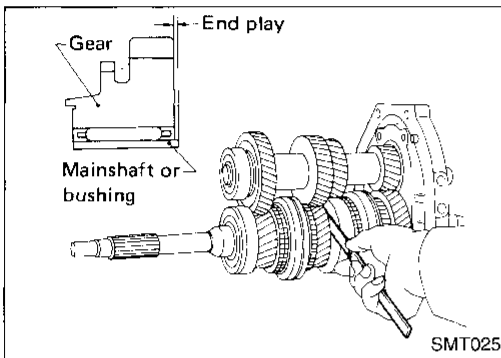

### Gear Components

1. Before disassembly, measure the end play of each gear.
  - If end play is not within the specified limit, disassemble and inspect the parts.
  - Replace any part which is worn or damaged.

#### Gear end play:

Refer to SDS, MT-32.

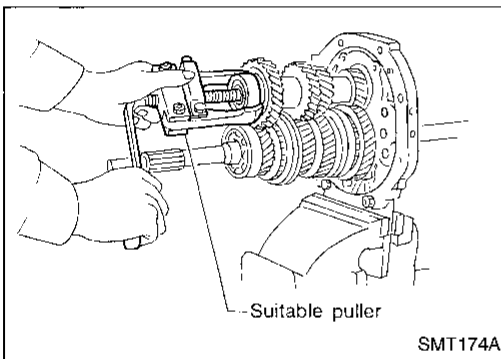

2. Mesh 2nd and reverse gear, then remove counter gear front bearing using a suitable puller.
3. Remove snap ring, then remove sub-gear bracket, sub-gear spring and sub-gear.

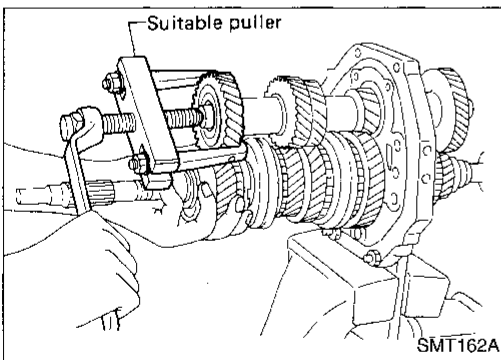

4. Remove counter drive gear together with main drive gear assembly using a suitable puller.
  - **When removing main drive gear assembly, be careful not to drop pilot bearing or baulk ring.**
5. Remove snap ring, then remove 3rd & 4th synchronizer assembly and 3rd main gear.

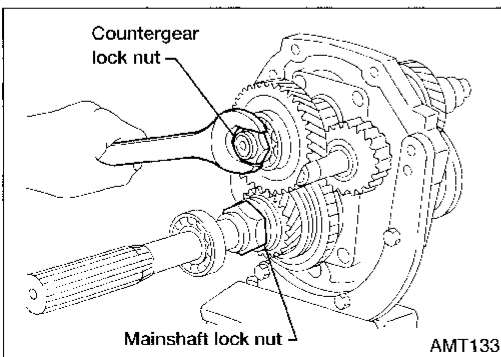

6. Disassemble parts at rear of adapter plate as follows:
  - a. Release staking on both countergear and mainshaft lock nuts, then loosen both nuts.

**Mainshaft Lock nut: Left-hand thread**



# DISASSEMBLY

## Gear Components (Cont'd)

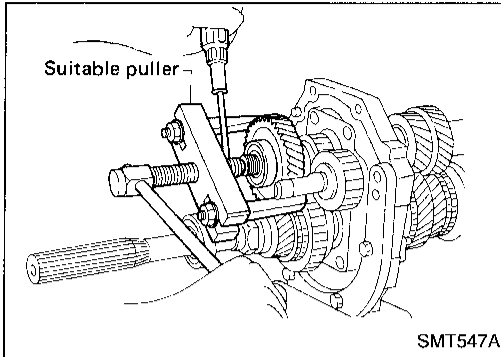

- b. Remove overdrive counter gear together with counter gear rear end bearing using a suitable puller.
- c. Remove reverse counter gear and spacer.
- d. Remove snap rings from reverse idler shaft, then remove reverse idler gear, thrust washers and reverse idler gear bearing.

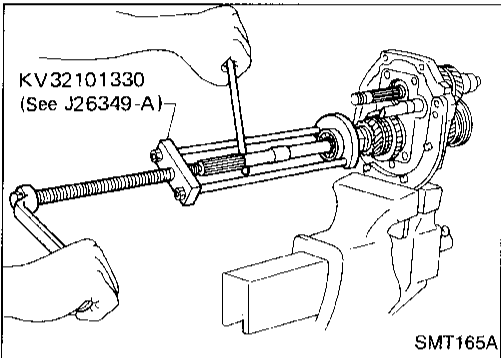

- e. Remove snap ring and pull out overdrive mainshaft bearing, then remove snap ring. (2WD model)
- f. Remove mainshaft lock nut.
- g. Remove speedometer drive gear and steel ball. (2WD model)
- h. Remove thrust washer, steel roller, roller bearing and washer.
- i. Remove overdrive main gear, needle bearing and baulk ring (overdrive).
- j. Remove counter gear by tapping on rear end of counter gear.
- k. Press out overdrive gear bushing and overdrive & reverse synchronizer assembly.
- l. Remove reverse main gear and needle bearing.

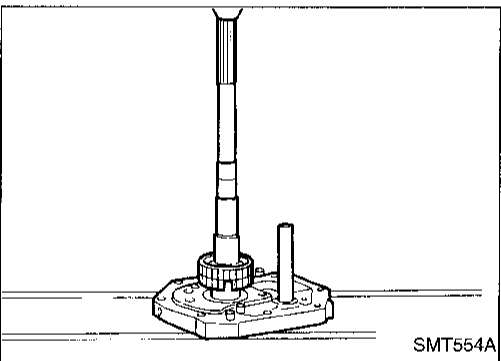

- m. Press out reverse gear bushing.

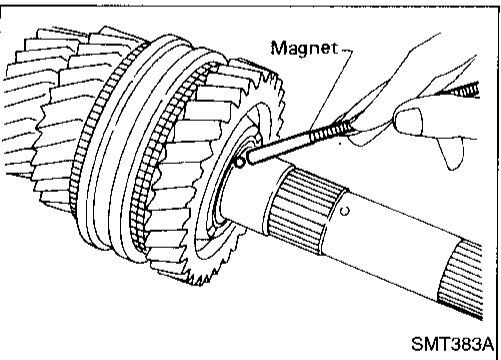

- 7. Remove thrust washer, steel ball, 1st main gear and needle bearing.
- **Be careful not to lose steel ball.**

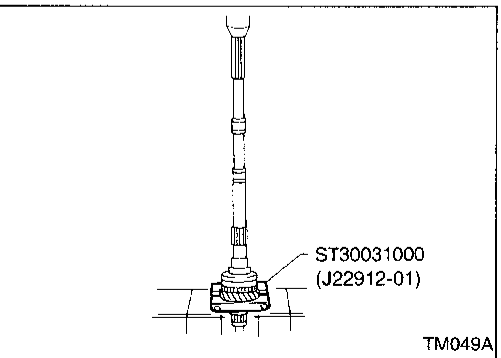

- 8. Press out 1st gear bushing together with 2nd main gear using Tool. Remove 2nd gear needle bearing.

GI

MA

EM

LC

EC

FE

CL

MT

AT

TF

PD

FA

RA

BR

ST

RS

BT

HA

EL

IDX

## DISASSEMBLY

### Gear Components (Cont'd)

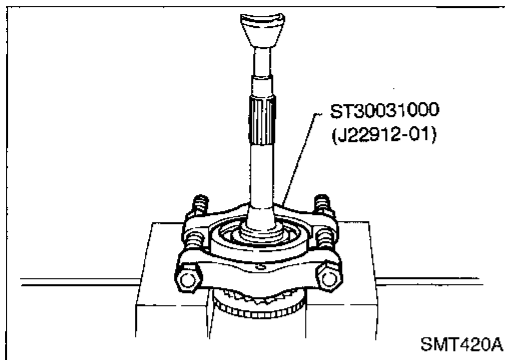

9. Remove main drive gear ball bearing.
  - a. Remove snap ring.
  - b. Remove main drive gear ball bearing.

## Shift Control Components

- Check contact and sliding surfaces of fork rods for wear, scratches, projections and other damage.

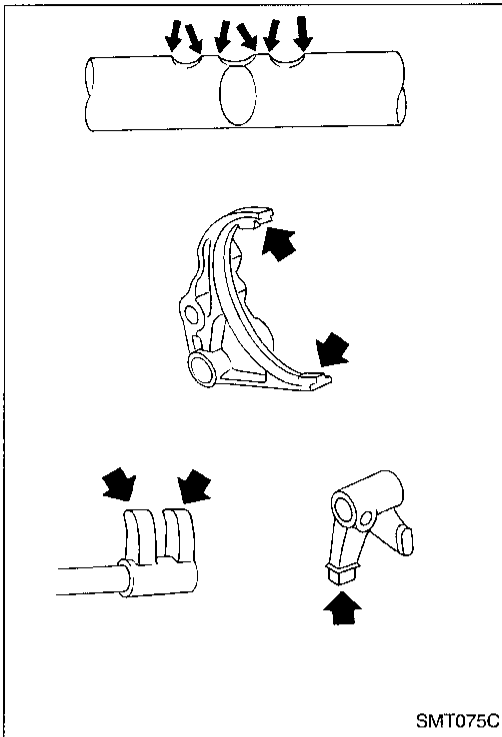

## Gear Components

### GEARS AND SHAFTS

- Check shafts for cracks, wear and bending.
- Check gears for excessive wear, chips and cracks.

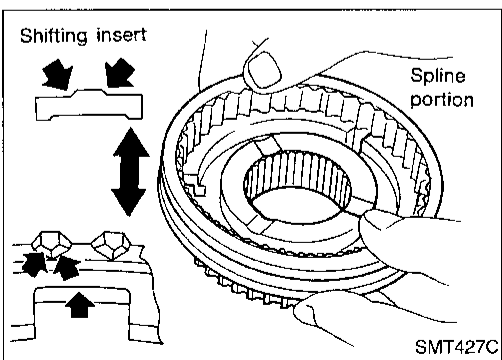
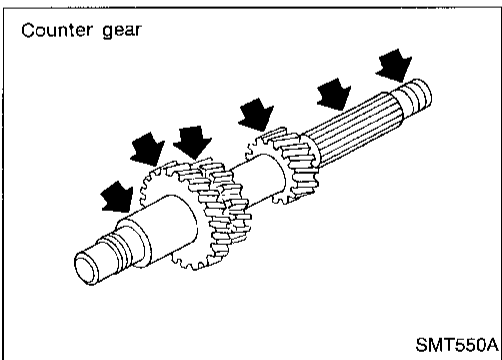
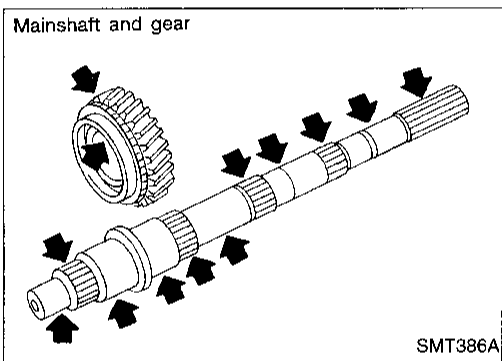

### SYNCHRONIZERS

- Check spline portion of coupling sleeves, synchronizer hubs and gears for wear, chips and cracks.
- Check baulk rings for cracks and deformation.
- Check shifting inserts for wear and deformation.
- Check insert spread springs for deformation.

GI

MA

EM

LC

EC

FE

CL

**MT**

AT

TF

PD

FA

RA

BR

ST

RS

BT

HA

EL

IDX

# INSPECTION

## Gear Components (Cont'd)

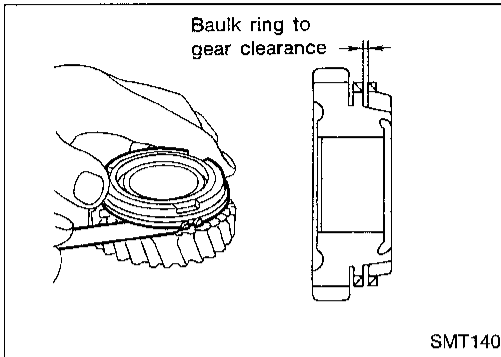

- Measure baulk ring wear.
  - a. Measure clearance between baulk ring and gear.

**Clearance between baulk ring and gear:**  
**Refer to SDS, MT-32.**
- If the clearance is less than the wear limit, replace baulk ring.

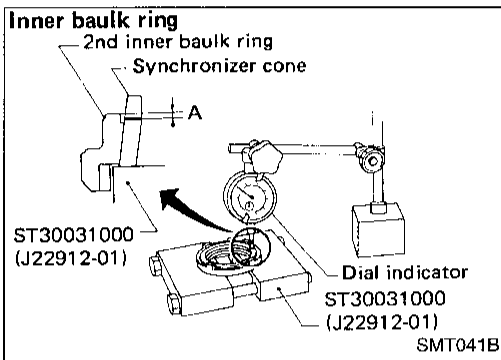

- Measure 2nd baulk ring wear—4WD model.
  - a. Place baulk rings in position on synchronizer cone.
  - b. While holding baulk rings against synchronizer cone as far as possible, measure dimensions "A" and "B".

### Standard:

Inner "A": 0.7 - 0.9 mm (0.028 - 0.035 in)

Outer "B": 0.6 - 1.1 mm (0.024 - 0.043 in)

### Wear limit:

0.2 mm (0.008 in)

- If dimension "A" or "B" is smaller than the wear limit, replace outer baulk ring, inner baulk ring and synchronizer cone as a set.

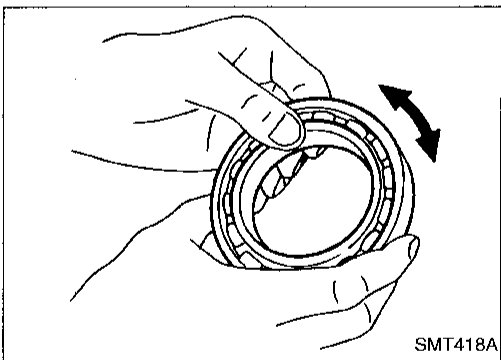
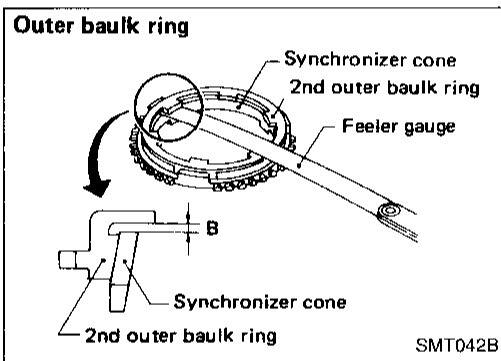

## BEARINGS

- Make sure all bearings roll freely and are free from noise, cracks, pitting or wear.

## Gear Components

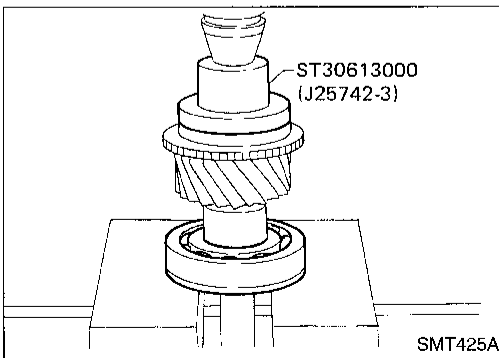
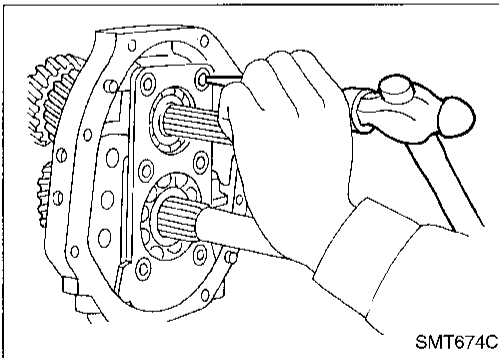
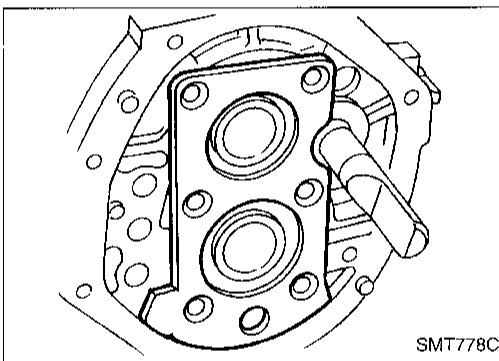
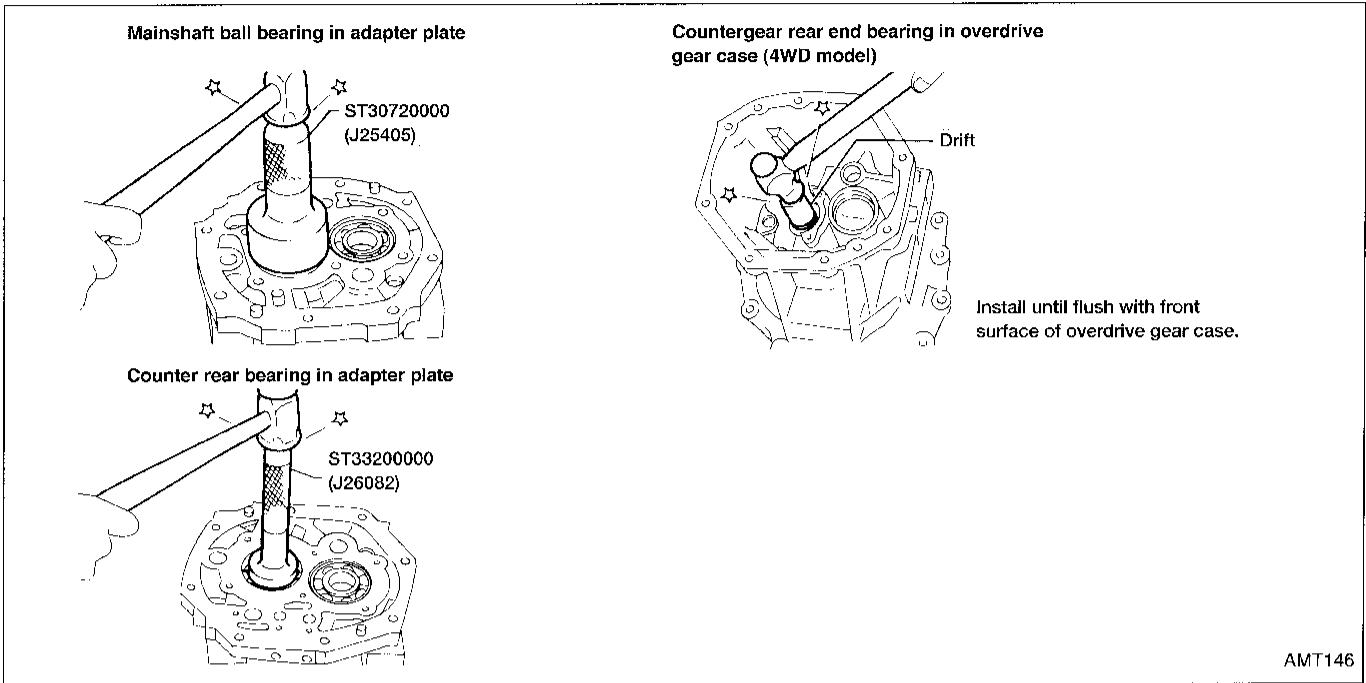

1. Install bearings into case components.
2. Assemble adapter plate parts.
  - Install oil gutter on adapter plate and expand on rear side.
  - Install bearing retainer.
    - a. Insert reverse idler shaft, then install bearing retainer.
  - b. Tighten each screw, then stake each one at two points.
3. Install main drive gear ball bearing.
  - a. Press main drive gear ball bearing.

GI

MA

EM

LC

EC

FE

CL

MT

AT

TF

PD

FA

RA

BR

ST

RS

BT

HA

EL

IDX

# ASSEMBLY

## Gear Components (Cont'd)

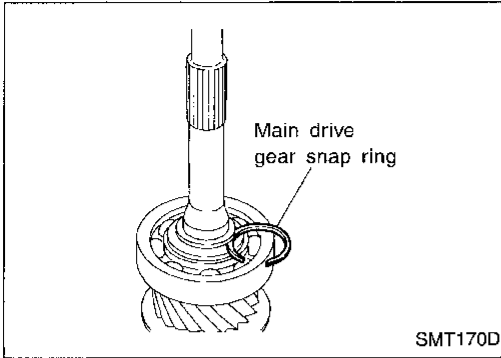

- b. Select and install proper main drive gear snap ring to achieve proper clearance of groove.

**Allowable clearance of groove:**

**0 - 0.13 mm (0 - 0.0051 in)**

**Main drive gear snap ring:**

**Refer to SDS, MT-32.**

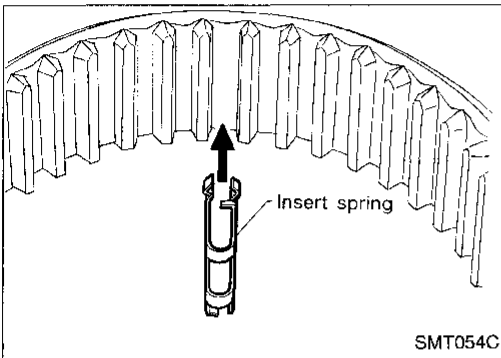

4. Assemble synchronizers.

- 1st and 2nd (2WD model) synchronizer

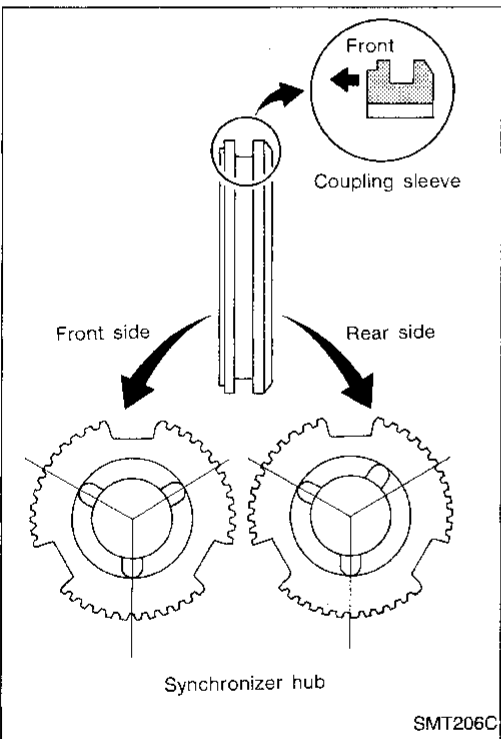

- Check coupling sleeve and synchronizer hub orientation.

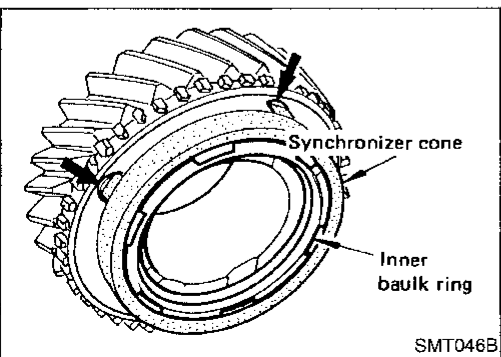

- 2nd double baulk ring type synchronizer (4WD model)

# ASSEMBLY

## Gear Components (Cont'd)

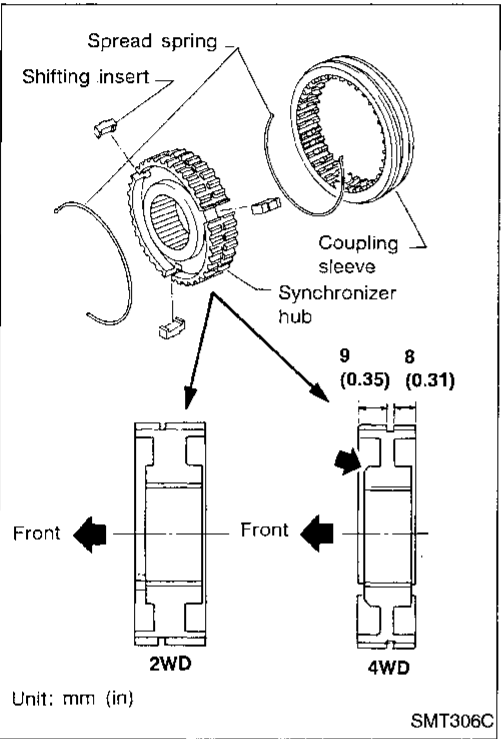
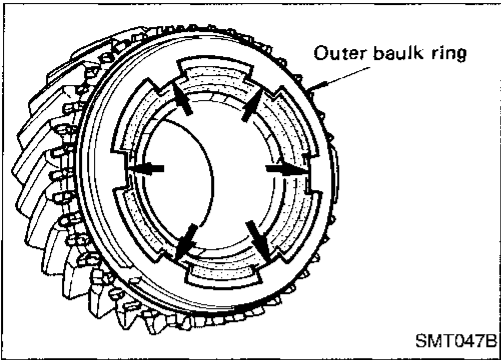

- 3rd & 4th synchronizer
- **The three synchronizer gutters should be at the rear.**

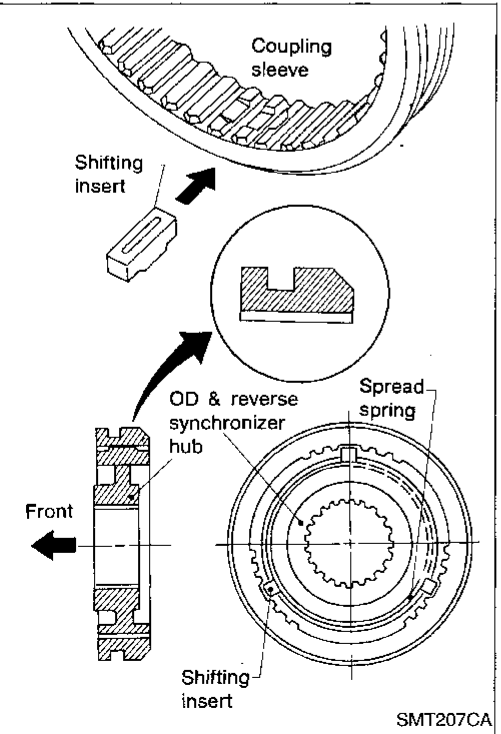

- Overdrive & reverse synchronizer

GI  
MA  
EM  
LC  
EC  
FE  
CL  
**MT**  
AT  
TF  
PD  
FA  
RA  
BR  
ST  
RS  
BT  
HA  
EL  
IDX

## ASSEMBLY

### Gear Components (Cont'd)

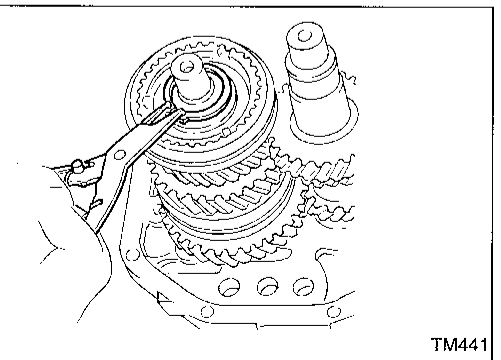
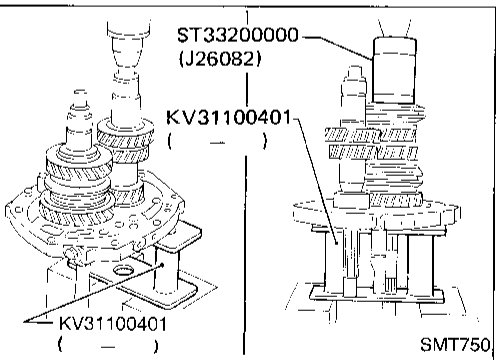
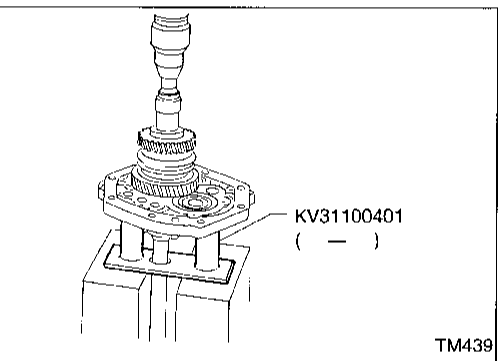
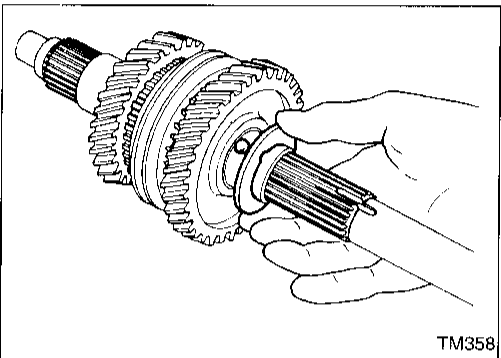
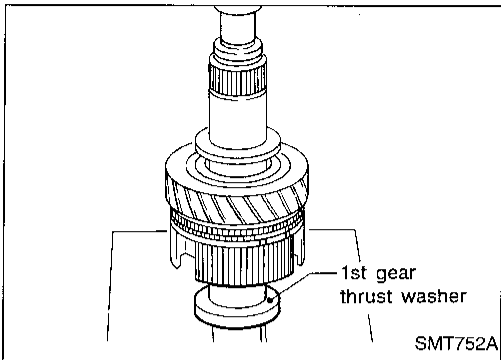

5. Assemble front side components to mainshaft.
  - a. Install 2nd main gear, needle bearing and 1st & 2nd synchronizer assembly; then press 1st gear bushing on mainshaft.
  - b. Install 1st main gear.

- c. Install steel ball and 1st gear washer.
      - **Before installation, apply multi-purpose grease to steel ball and to both sides of the 1st gear washer.**

6. Install mainshaft and counter gear on adapter plate and main drive gear on mainshaft as follows:

- a. Press mainshaft assembly into adapter plate using Tool.

- b. Press counter gear into adapter plate using Tool.

- c. Install 3rd main gear and needle bearing, then press 3rd & 4th synchronizer assembly onto mainshaft.

- **Pay attention to the direction of 3rd & 4th synchronizer.**

- d. Install front mainshaft snap ring.  
Select proper front mainshaft snap ring to achieve proper clearance of groove.

**Allowable clearance of groove:**

**0 - 0.18 mm (0 - 0.0071 in)**

**Mainshaft front snap ring:**

**Refer to SDS, MT-32.**

- e. Apply gear oil to mainshaft pilot bearing and install it on mainshaft.



# ASSEMBLY

## Gear Components (Cont'd)

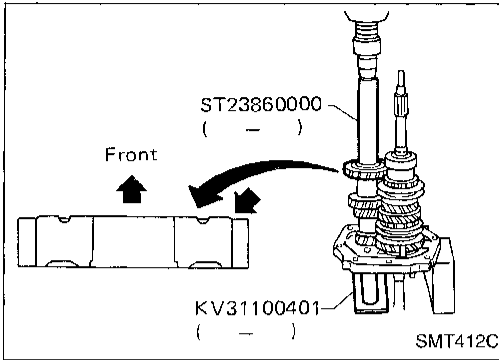

- f. Press counter drive gear together with main drive gear using Tool.
- Pay attention to the direction of counter drive gear.

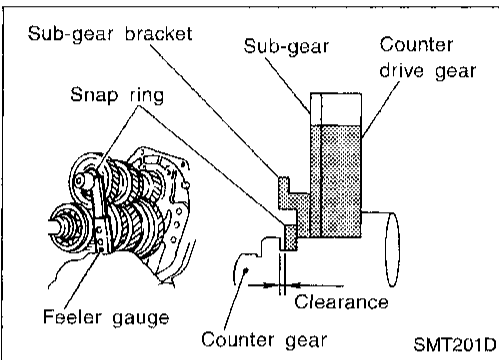

- g. Install sub-gear components.
- (1) Install sub-gear and sub-gear bracket on counter drive gear and then select proper snap ring that will minimize clearance of groove in counter gear.
- Do not install sub-gear spring at this time.
- Allowable clearance of groove:  
0 - 0.18 mm (0 - 0.0071 in)
- Counter drive gear snap ring:  
Refer to SDS, MT-32.

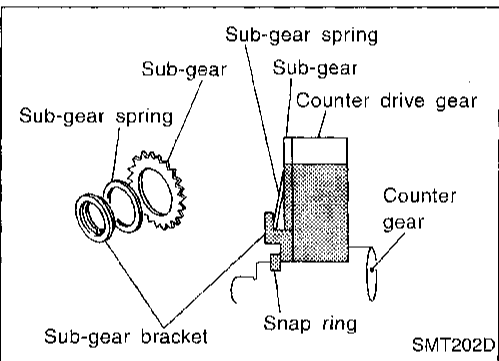

- (2) Remove snap ring, sub-gear bracket and sub-gear from counter gear.
- (3) Reinstall sub-gear, sub-gear spring, sub-gear bracket and snap ring.

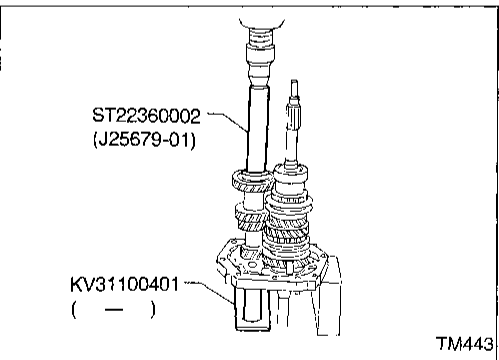

- h. Press countergear front bearing onto counter gear using Tool.

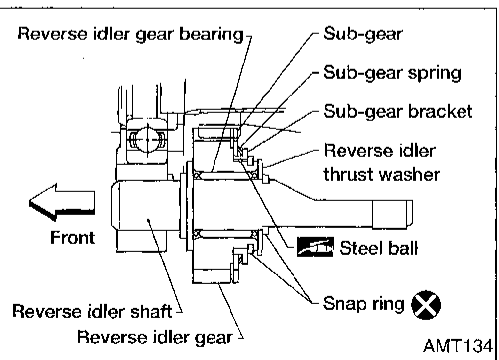

7. Install rear side components on mainshaft and counter gear as follows:
- a. Install sub-gear parts (sub-gear, sub-gear spring, sub-gear bracket, steel ball and snap ring) on the reverse idler gear.
- b. Install reverse idler gear to reverse idler shaft along with reverse idler thrust washer, snap rings and reverse idler gear bearing.

GI

MA

EM

LC

EC

PE

CL

MT

AT

TF

PD

FA

RA

BR

ST

RS

BT

HA

EL

IDX

# ASSEMBLY

## Gear Components (Cont'd)

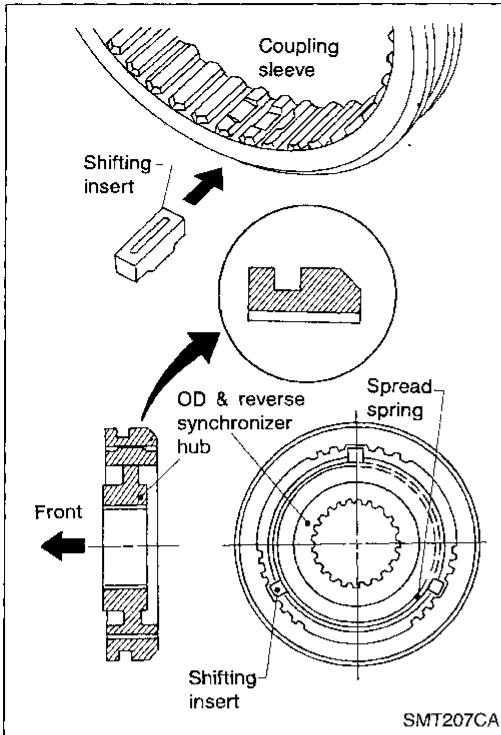

- c. Install bushing, reverse main gear and overdrive & reverse synchronizer to mainshaft.
- **Pay attention to the direction of synchronizer hub.**

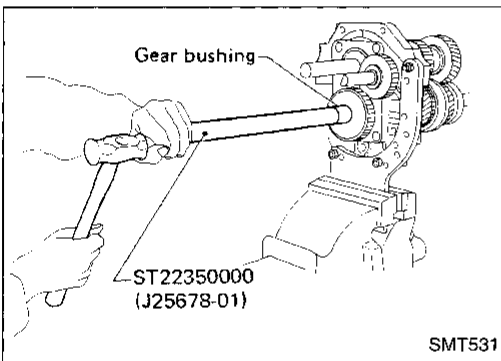

- d. Install overdrive gear bushing to mainshaft using Tool.
- e. Install overdrive main gear and needle bearing to mainshaft.
- f. Install spacer, reverse counter gear and overdrive counter gear to countergear.
- **OD main gear and OD counter gear should be handled as a matched set.**
- g. Install washer, roller bearing, steel roller and thrust washer.
- h. Tighten mainshaft lock nut temporarily.
- **Always use new lock nut.**

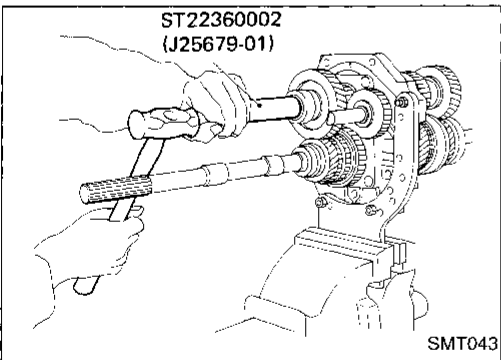

- i. Install countergear rear end bearing using Tool.

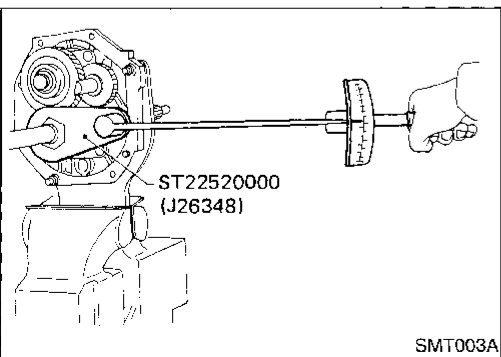

- 8. Mesh 2nd and reverse gears, then tighten mainshaft lock nut using Tool.
- **Always use new lock nut.**  
**Mainshaft lock nut:**  
ⓘ: 137 - 167 N·m (14.0 - 17.0 kg-m, 101 - 123 ft-lb)

# ASSEMBLY

## Gear Components (Cont'd)

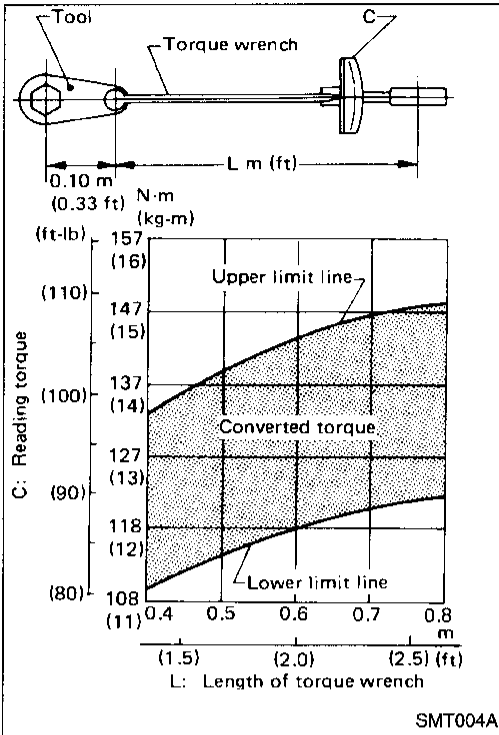

- Use the chart shown at left to determine the proper reading torque. (Length of torque wrench vs. setting or reading torque)  
Reference: Formula to convert torque wrench indication to the true torque value:

$$T = \frac{0.1 \text{ m (0.33 ft)} + L}{L} \times C$$

If the specified torque is T kg-m (ft-lb), the torque wrench scale indication C is determined using the following formula.

$$C = \frac{T \times L}{0.1 \text{ m (0.33 ft)} + L}$$

- Tighten counter gear lock nut.

- Always use new lock nut.**

**Counter gear lock nut:**

: 98 - 127 N·m (10.0 - 13.0 kg·m, 72 - 94 ft·lb)

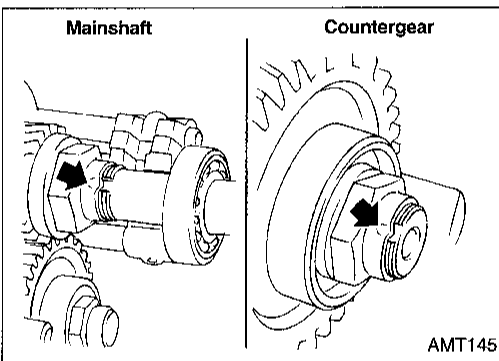

- Stake mainshaft lock nut and counter gear lock nut using a punch.

- Measure gear end play. Refer to "Gear Components", "DISASSEMBLY", MT-16.

- Install snap ring and OD mainshaft bearing, then snap ring (2WD model only).

**Allowable clearance:**

0 - 0.14 mm (0 - 0.0055 in)

**OD mainshaft bearing snap ring:**

Refer to SDS, MT-32.

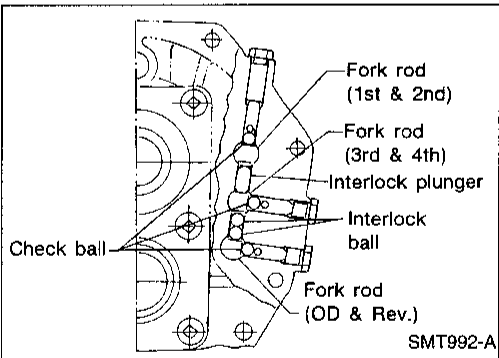

## Shift Control Components

- Install fork rods, interlock plunger, interlock balls and check balls.

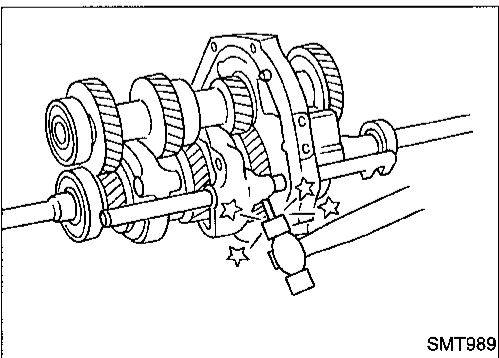

- Install 1st & 2nd shift fork, then drive in retaining pin.

## ASSEMBLY

### Shift Control Components (Cont'd)

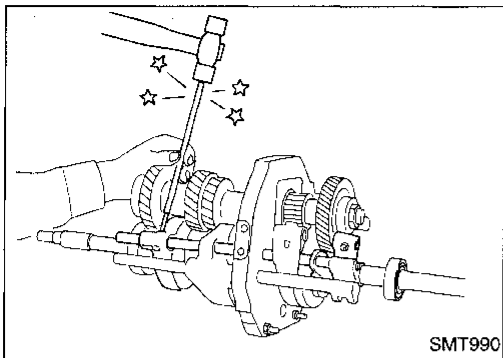

3. Install 3rd & 4th shift fork, then drive in retaining pin.

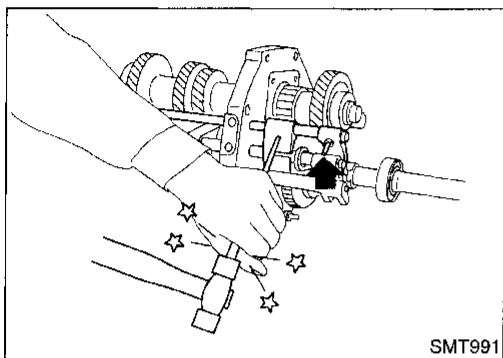

4. Install overdrive & reverse shift fork, then drive in retaining pin.

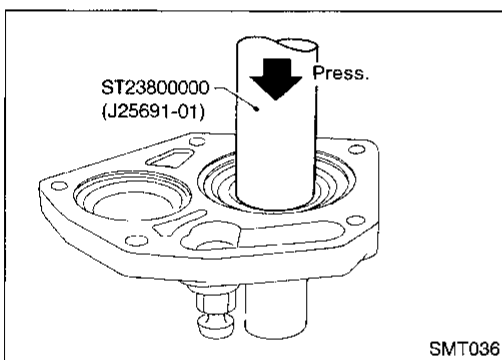

### Case Components

1. Install front cover oil seal using Tool.
  - Apply multi-purpose grease to seal lip.

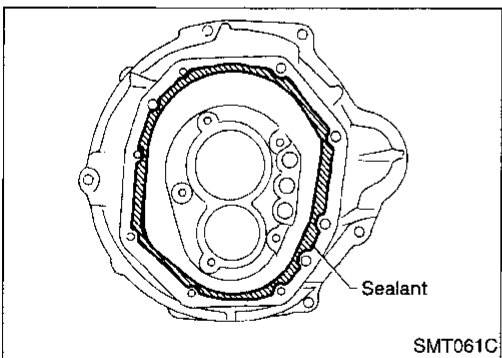

2. Apply sealant to mating surface of transmission case as shown at left.
  - Use genuine anaerobic liquid gasket, Three Bond TB1215, Loctite Part No. 51813 or equivalent.

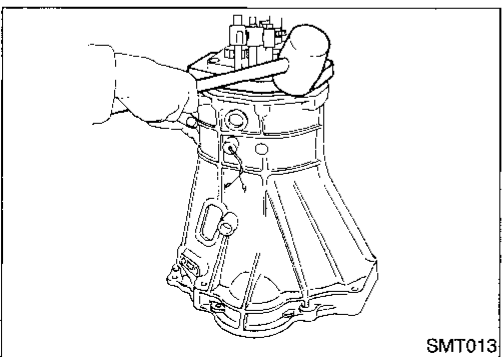

3. Slide gear assembly onto adapter plate by lightly tapping it using a soft hammer.

# ASSEMBLY

## Case Components (Cont'd)

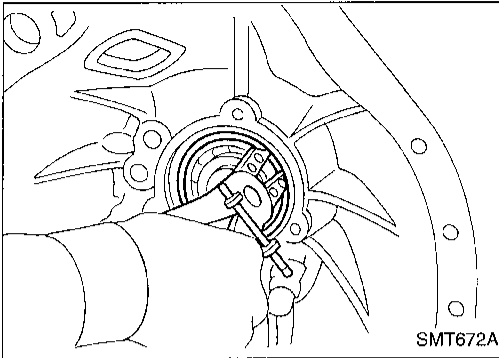

4. Install main drive gear ball bearing snap ring.

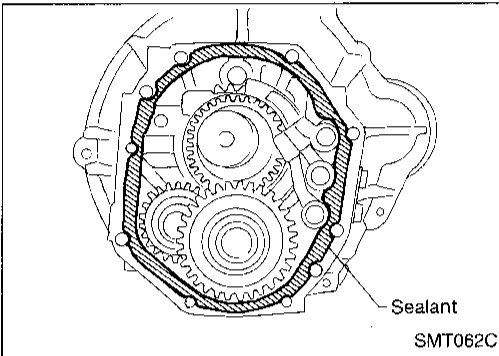

5. Apply sealant to mating surface of adapter plate as shown at left.

- Use genuine anaerobic liquid gasket Three Bond TB1215, Loctite Part No. 51813 or equivalent.

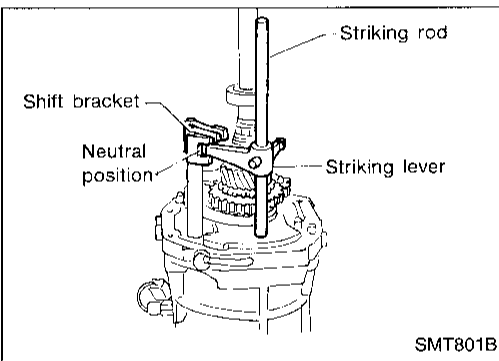

6. Place shift forks in neutral position.

7. Install striking lever and rod onto adapter plate and align striking lever with shift brackets.

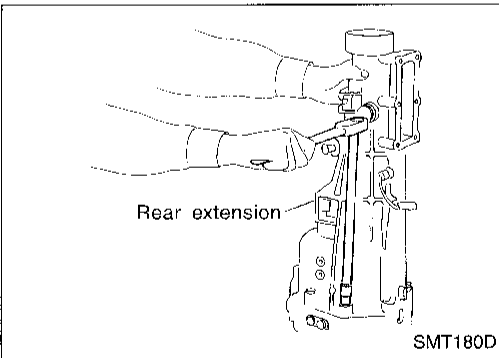

8. Install rear extension.

- Tighten mounting bolts equally in a criss-cross pattern.

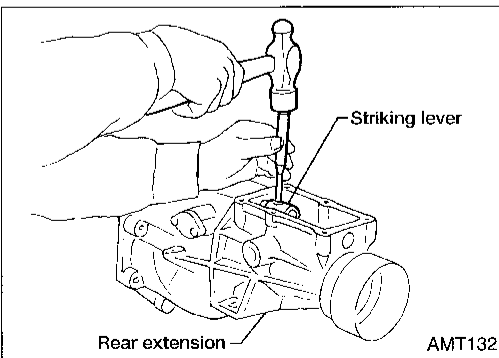

9. Install striking lever retaining pin.

GI

MA

EM

LC

EC

FE

CL

**MT**

AT

TF

PD

FA

RA

BR

ST

RS

BT

HA

EL

IDX

## ASSEMBLY

### Case Components (Cont'd)

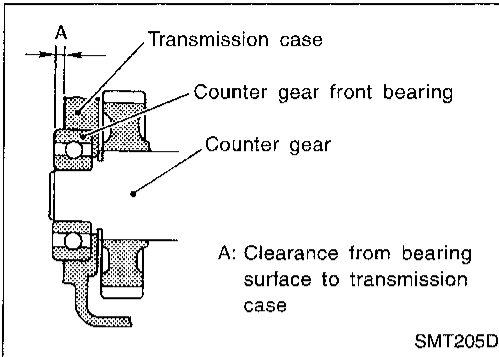

10. Select counter gear front bearing shim.  
**Allowable clearance (A) from bearing surface to transmission case:**  
**0 - 0.16 mm (0 - 0.0063 in)**  
**Countershaft front bearing shim:**  
**Refer to SDS, MT-33.**
11. Install gasket and front cover.

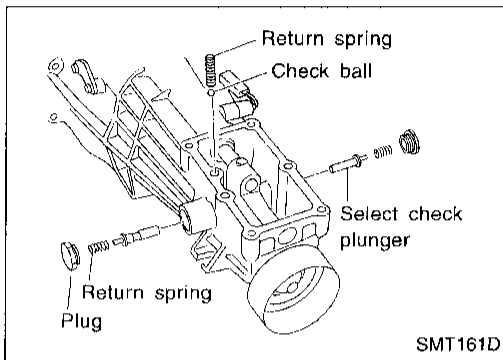

12. Install return spring plugs, check ball, return springs and select check plungers.
13. Install control housing and gasket.

# SERVICE DATA AND SPECIFICATIONS (SDS)

## General Specifications

Applied model	2WD	4WD
Transmission	FS5W71C	
Number of speed	5	
Shift pattern		
Synchromesh type	Warner	
Gear ratio	Gear ratio	
1st	3.321	3.592
2nd	1.902	2.246
3rd	1.308	1.415
4th	1.000	1.000
OD	0.838	0.821
Reverse	3.382	3.657
Mainshaft	Number of teeth	
Drive	22	21
1st	33	33
2nd	27	28
3rd	26	26
OD	22	21
Reverse	36	36
Countershaft gear	Number of teeth	
Drive	31	32
1st	14	14
2nd	20	19
3rd	28	28
OD	37	39
Reverse	15	15
Reverse idler gear	21	21
Oil capacity ℓ (US pt, Imp pt)	2.0 (4-1/4, 3-1/2)	4.9 (10-3/8, 8-5/8)
Remarks	Reverse synchronizer	
	—	2nd double baulk ring type synchronizer
	Sub-gear	
	Sub-gear set installs countergear and reverse idler shaft.	

GI

MA

EM

LC

EC

FE

CL

MT

AT

TF

PD

FA

RA

BR

ST

RS

BT

HA

EL

DX

# SERVICE DATA AND SPECIFICATIONS (SDS)

## Inspection and Adjustment

### GEAR END PLAY

Unit: mm (in)

1st gear	0.31 - 0.41 (0.0122 - 0.0161)
2nd gear	0.11 - 0.21 (0.0043 - 0.0083)
3rd gear	0.11 - 0.21 (0.0043 - 0.0083)
Overdrive gear	0.24 - 0.41 (0.0094 - 0.0161)

### CLEARANCE BETWEEN BAULK RING AND GEAR

Unit: mm (in)

Standard	
1st & 2nd (2WD)	1.20 - 1.60 (0.0472 - 0.0630)
3rd & main drive	1.20 - 1.60 (0.0472 - 0.0630)
Overdrive	1.20 - 1.60 (0.0472 - 0.0630)
Reverse	1.10 - 1.55 (0.0433 - 0.0610)
Wear limit	
1st & 2nd (2WD)	0.80 (0.0315)
3rd & main drive	0.80 (0.0315)
Overdrive	0.80 (0.0315)
Reverse	0.70 (0.0276)

### 2nd baulk ring (4WD model)

Unit: mm (in)

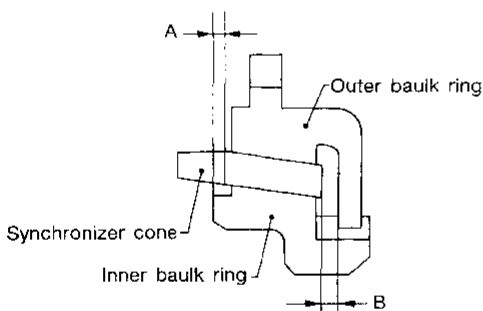

SMT733C

Dimension	Standard	Wear limit
A	0.7 - 0.9 (0.028 - 0.035)	0.2 (0.008)
B	0.6 - 1.1 (0.024 - 0.043)	

### AVAILABLE SNAP RINGS

#### Main drive gear bearing

Allowable clearance		0 - 0.13 mm (0 - 0.0051 in)
Thickness	mm (in)	Part number
1.87	(0.0736)	32204-78001
1.94	(0.0764)	32204-78002
2.01	(0.0791)	32204-78003

#### Mainshaft front

Allowable clearance		0 - 0.18 mm (0 - 0.0071 in)
Thickness	mm (in)	Part number
2.4	(0.094)	32263-V5200
2.5	(0.098)	32263-V5201

#### Counter drive gear

Allowable clearance		0 - 0.18 mm (0 - 0.0071 in)
Thickness	mm (in)	Part number
1.4	(0.055)	32215-E9000
1.5	(0.059)	32215-E9001
1.6	(0.063)	32215-E9002

#### OD mainshaft bearing (2WD model)

Allowable clearance		0 - 0.14 mm (0 - 0.0055 in)
Thickness	mm (in)	Part number
1.1	(0.043)	32228-20100
1.2	(0.047)	32228-20101
1.3	(0.051)	32228-20102
1.4	(0.055)	32228-20103



# SERVICE DATA AND SPECIFICATIONS (SDS)

## Inspection and Adjustment (Cont'd)

### AVAILABLE SHIMS

#### Countershaft front bearing

Unit: mm (in)

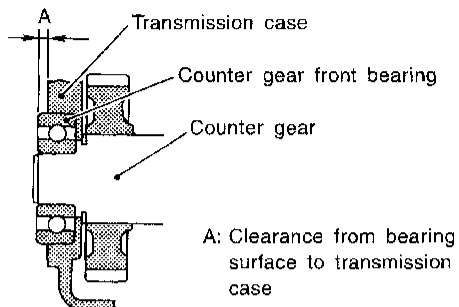

SMT205D

"A"	Thickness of shim	Part number
4.52 - 4.71 (0.1780 - 0.1854)	Not necessary	
4.42 - 4.51 (0.1740 - 0.1776)	0.1 (0.004)	32218-V5000
4.32 - 4.41 (0.1701 - 0.1736)	0.2 (0.008)	32218-V5001
4.22 - 4.31 (0.1661 - 0.1697)	0.3 (0.012)	32218-V5002
4.12 - 4.21 (0.1622 - 0.1657)	0.4 (0.016)	32218-V5003
4.02 - 4.11 (0.1583 - 0.1618)	0.5 (0.020)	32218-V5004
3.92 - 4.01 (0.1543 - 0.1579)	0.6 (0.024)	32218-V5005

GI

MA

EM

LC

EC

FE

CL

**MT**

AT

TF

PD

FA

RA

BR

ST

RS

BT

HA

EL

IDX