

SECTION **FFD**
FRONT FINAL DRIVE

A
B
C

FFD

CONTENTS

E

PRECAUTIONS	2	REAR COVER GASKET	11	F
Precautions	2	Removal and Installation	11	
Precautions for Liquid Gasket	2	REMOVAL	11	
REMOVAL OF LIQUID GASKET SEALING	2	INSTALLATION	11	G
LIQUID GASKET APPLICATION PROCEDURE.....	2	FRONT FINAL DRIVE ASSEMBLY	12	
PREPARATION	4	Removal and Installation	12	
Special Service Tools	4	REMOVAL	12	H
Commercial Service Tools	6	INSTALLATION	13	
NOISE, VIBRATION AND HARSHNESS (NVH)		Disassembly and Assembly	14	
TROUBLESHOOTING	7	COMPONENTS	14	I
NVH Troubleshooting Chart	7	ASSEMBLY INSPECTION AND ADJUSTMENT..	15	
FRONT OIL SEAL	8	DISASSEMBLY	17	
Removal and Installation	8	INSPECTION AFTER DISASSEMBLY	22	
REMOVAL	8	ADJUSTMENT AND SELECTION OF ADJUST-		J
INSTALLATION	9	ING WASHERS	23	
SIDE OIL SEALS	10	ASSEMBLY	24	
Removal and Installation	10	SERVICE DATA AND SPECIFICATIONS (SDS)	32	K
REMOVAL	10	General Specifications	32	
		Side Gear Adjustment	32	
		Total Preload Adjustment	32	L
		Drive Pinion Height Adjustment	33	

M

PRECAUTIONS

PF0:00001

PRECAUTIONS

Precautions

EDS0034E

CAUTION:

- Before starting diagnosis of the vehicle, understand symptoms well. Perform correct and systematic operations.
- Check for the correct installation status prior removal or disassembly. When matching marks are required, be sure they do not interfere with the function of the parts they are applied to.
- Carry out an overhaul in a clean work place, Using a dust proof room is recommended.
- Before disassembly, using steam or white gasoline, completely remove sand and mud from the exterior the unit, preventing them from entering into the unit during disassembly or assembly.
- Check appearance of the disassembled parts for damage, deformation, and abnormal wear. If a malfunction is detected, replace it with a new one.
- Normally replace lock pins, oil seals, and bearings with new ones every times they are removed.
- In principle, tighten bolts or nuts gradually in several steps working diagonally from inside to outside. If tightening sequence is specified, observe it.
- Clean and flush the parts sufficiently and blow them dry.
- Be careful not to damage the sliding surfaces and mating surface.
- When applying sealant, remove the old sealant from the mounting surface; then remove any moisture, oil, and foreign materials from the application and mounting surfaces.
- Always use shop paper for cleaning the inside of components.
- Avoid using cotton gloves or a shop cloth to prevent entering of lint.
- During assembly, observe the specified tightening torque, and new differential gear oil, Vaseline, or multi-purpose grease, as specified for each vehicle, when necessary.

Precautions for Liquid Gasket

EDS0034F

REMOVAL OF LIQUID GASKET SEALING

- After removing nuts and bolts, separate the mating surface and remove old liquid gasket sealing using Tool.

Tool number : KV10111100 (J-37228)

CAUTION:

Be careful not to damage the mating surfaces.

- Tap seal cutter to insert it, and then slide it by tapping on the side as shown.
- In areas where Tool is difficult to use, use plastic hammer to lightly tap the parts, to remove it.

CAUTION:

If for some unavoidable reason tool such as screwdriver is used, be careful not to damage the mating surfaces.

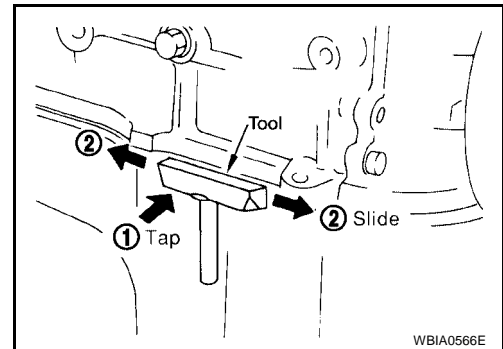

WBIA0566E

LIQUID GASKET APPLICATION PROCEDURE

1. Using scraper, remove old liquid gasket adhering to the gasket application surface and the mating surface.
 - Remove liquid gasket completely from the groove of the gasket application surface, bolts, and bolt holes.
2. Thoroughly clean the mating surfaces and remove adhering moisture, grease and foreign materials.

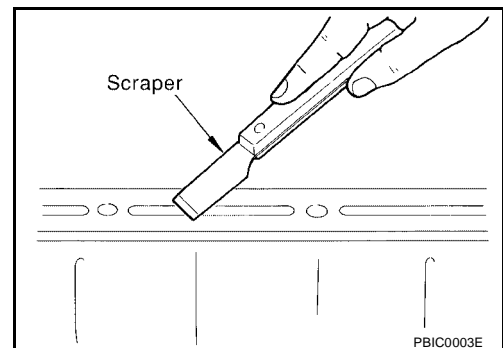

PBIC0003E

PRECAUTIONS

3. Attach liquid gasket tube to Tool.

Tool number : WS39930000 (—)

Use Genuine RTV Silicone Sealant or equivalent. Refer to GI-45, "RECOMMENDED CHEMICAL PRODUCTS AND SEALANTS" .

4. Apply liquid gasket without breaks to the specified location with the specified dimensions.

- If there is a groove for liquid gasket application, apply liquid gasket to the groove.

- As for bolt holes, normally apply liquid gasket inside the holes. Occasionally, it should be applied outside the holes. Make sure to read the text of this manual.
- Within five minutes of liquid gasket application, install the mating component.
- If liquid gasket protrudes, wipe it off immediately.
- Do not retighten nuts or bolts after the installation.
- After 30 minutes or more have passed from the installation, fill engine oil and engine coolant.

CAUTION:

If there are specific instructions in this manual, observe them.

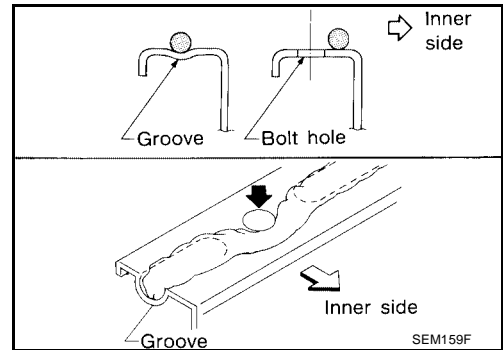
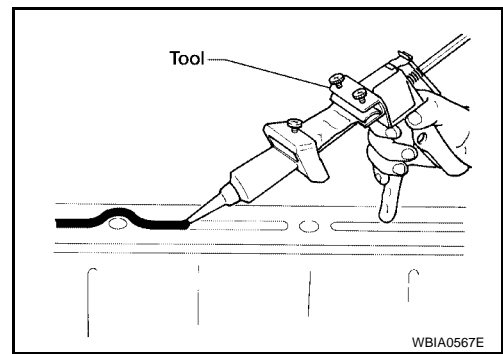

A
B
C
FFD

E
F
G
H
I
J
K
L
M

PREPARATION

PFP:00002

EDS0034G

PREPARATION

Special Service Tools

The actual shapes of Kent-Moore tools may differ from those of special service tools illustrated here.

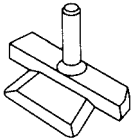
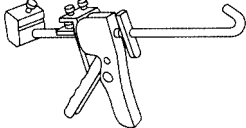
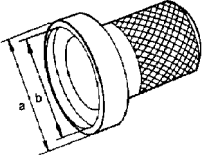
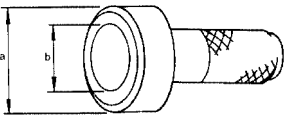
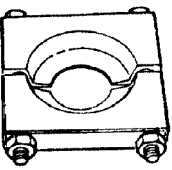
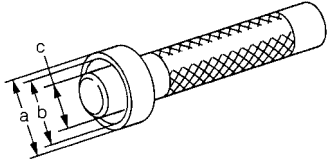
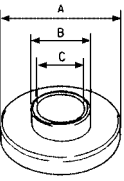
Tool number (Kent-Moore No.) Tool name	Description
KV10111100 (J-37228) Seal cutter	Removing steel oil pan and rear timing chain case  <p style="text-align: center;">S-NT046</p>
WS39930000 (—) Tube presser	Pressing the tube of liquid gasket  <p style="text-align: center;">S-NT052</p>
ST35271000 (—) Drift	Installing drive pinion front bearing outer race. a: 72 mm (2.83 in) dia. b: 36 mm (1.42 in) dia.  <p style="text-align: center;">ZZA0702D</p>
KV38100500 (J-25273) Drift	Installing front oil seal. a: 80 mm (3.15 in) dia. b: 60 mm (2.36 in) dia.  <p style="text-align: center;">ZZA0811D</p>
ST30021000 (—) Puller	<ul style="list-style-type: none"> ● Removing side bearing inner race. ● Removing drive pinion rear bearing inner race.  <p style="text-align: center;">ZZA0700D</p>
KV38100300 (J-25523) Drift	Installing side bearing inner race. a: 54 mm (2.13 in) dia. b: 46 mm (1.81 in) dia. c: 32mm (1.26 in) dia.  <p style="text-align: center;">ZZA1046D</p>
ST30901000 (—) Drift	Installing drive pinion rear bearing outer race. A: 79mm (3.11 in) dia. B: 45 mm (1.77 in) dia. C: 35.2 mm (1.39 in) dia.  <p style="text-align: center;">SDIA0217J</p>

PREPARATION

Tool number (Kent-Moore No.) Tool name	Description	
KV40104810 (—) Drift	Installing drive pinion front bearing outer race. a: 68 mm (2.68 in) dia. b: 55 mm (2.17 in) dia.	A B C
KV38102200 (—) Drift	Installing front oil seal. a: 90 mm (3.54 in) dia. b: 55.3 mm (2.18 in) dia.	FFD E
ST33081000 (—) Adapter	Removing and installing side bearing inner race. a: 43 mm (1.69 in) dia. b: 33.5 mm (1.32 in) dia.	F G H
KV38108300 (J-44195) Companion flange wrench	Removing and installing drive pinion nut.	I J
ST3127S000 (J-25765-A) Preload gauge 1. GG91030000 (J-25765) Torque wrench 2. HT62940000 (—) Socket adapter (1/2") 3. HT62900000 (—) Socket adapter (3/8")	Inspecting drive pinion bearing preload and total preload	K L M
— (C-4040) Installer	Installing drive pinion rear bearing inner race.	
KV40105230 (—) Drift	Installing drive pinion rear bearing outer race. a: 92 mm(3.62 in) dia. b: 85.5 mm (3.37 in) dia.	

PREPARATION

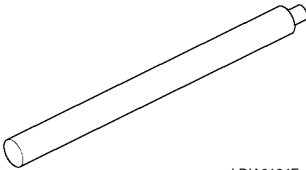
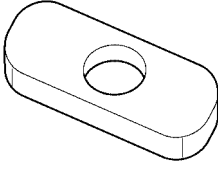
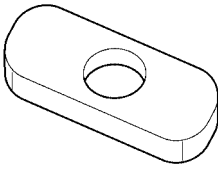
Tool number (Kent-Moore No.) Tool name	Description
— (C-4171) Handle	 <p style="text-align: right;">LDIA0134E</p> <ul style="list-style-type: none"> ● Removing drive pinion front bearing outer race ● Removing drive pinion rear bearing outer race
— (D-103) Remover	 <p style="text-align: right;">LDIA0135E</p> <p>Removing drive pinion front bearing outer race</p>
— (C-4307) Remover	 <p style="text-align: right;">LDIA0135E</p> <p>Removing drive pinion rear bearing outer race</p>

Commercial Service Tools

EDS0034H

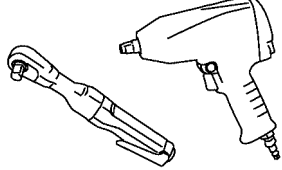
Tool name	Description
— (SP8P) Slide hammer	 <p style="text-align: right;">LDIA0133E</p> <ul style="list-style-type: none"> ● Removing front oil seal ● Removing side oil seal
Power tool	 <p style="text-align: right;">PBIC0190E</p> <p>Loosening bolts and nuts</p>

NOISE, VIBRATION AND HARSHNESS (NVH) TROUBLESHOOTING

NOISE, VIBRATION AND HARSHNESS (NVH) TROUBLESHOOTING

PF0:0003

NVH Troubleshooting Chart

EDS00341

Use the chart below to help you find the cause of the symptom. If necessary, repair or replace these parts.

Symptom	Differential	Noise	Reference page
Possible cause and suspected parts	x	Rough gear tooth	FFD-15
	x	Improper gear contact	FFD-15
	x	Tooth surfaces worn	FFD-15
	x	Incorrect backlash	FFD-16
	x	Companion flange excessive runout	FFD-16
	x	Improper gear oil	MA-26. "Checking Final Drive Oil"
	x	Propeller shaft	PR-3. "NVH Troubleshooting Chart"
	x	Axle and suspension	FAX-4. "NVH Troubleshooting Chart" and RAX-4. "NVH Troubleshooting Chart"
	x	Tires	WT-3. "NVH Troubleshooting Chart"
	x	Road wheel	WT-3. "NVH Troubleshooting Chart"
	x	Drive shaft	FAX-4. "NVH Troubleshooting Chart"
	x	Brakes	BR-5. "NVH Troubleshooting Chart"
	x	Steering	PS-5. "NVH Troubleshooting Chart"

x: Applicable

A
B
C
FFD
E
F
G
H
I
J
K
L
M

FRONT OIL SEAL

FRONT OIL SEAL

PFP:38189

Removal and Installation REMOVAL

EDS0034J

1. Remove front propeller shaft. Refer to [PR-5, "REMOVAL"](#) .
2. Separate the RH and LH drive shafts from the front final drive. Refer to [FAX-7, "REMOVAL"](#) .
3. Measure the drive pinion bearing preload with front oil seal resistance using Tool.

Tool number : ST3127S000 (J-25765-A)

NOTE:

Record the preload measurement.

4. Loosen drive pinion nut while holding the companion flange using Tool.

Tool number : KV38108300 (J-44195)

5. Remove companion flange using a suitable puller.

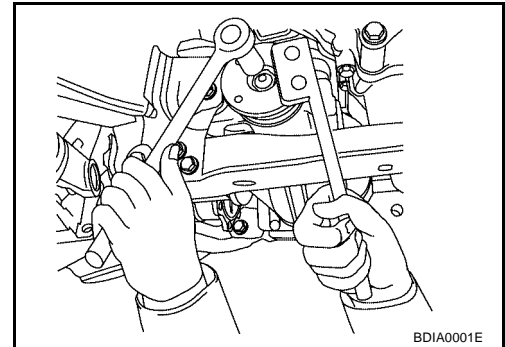

6. Place a small hole in seal case, using a suitable punch or drill.

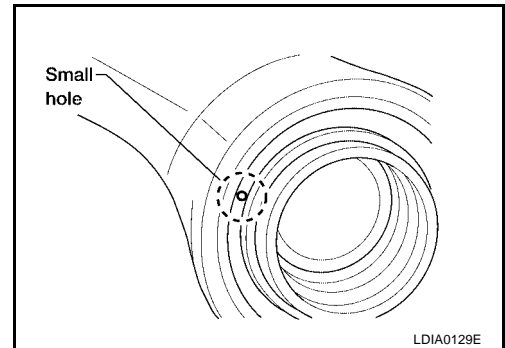

7. Assemble Tool as shown and remove seal.

Tool number : SP8P

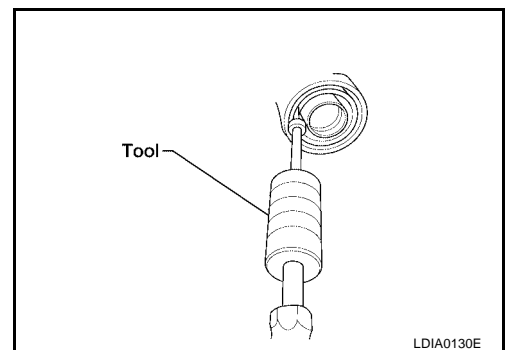

FRONT OIL SEAL

INSTALLATION

1. Apply multi-purpose grease to cavity at sealing lips of front oil seal. Press front oil seal into gear carrier using suitable tool.

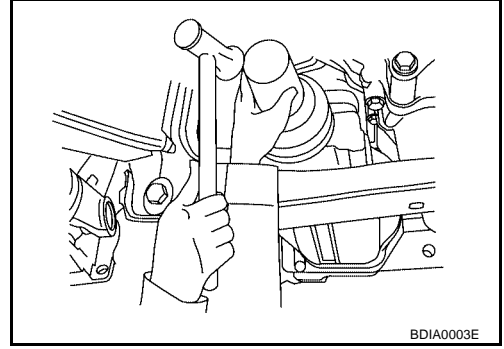

2. Install companion flange and a new drive pinion nut. Tighten drive pinion nut while holding the companion flange using Tool until there is no end play.

Tool number : KV38108300 (J-44195)

3. Measure the drive pinion bearing preload with front oil seal resistance using Tool.

Tool number : ST3127S000 (J-25765-A)

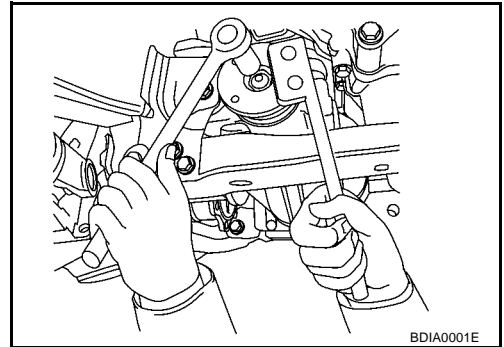

NOTE:

- Drive pinion bearing preload should equal the measurement taken during removal plus an additional 0.56 N-m (0.06 Kg-m, 5 in-lb).
- If drive pinion bearing preload is low, tighten drive pinion nut in 6.8 N-m (0.69 Kg-m, 5ft-lb) increments until drive pinion preload is met.

CAUTION:

Never loosen the drive pinion nut to decrease drive pinion bearing preload. Do not exceed specified preload. If preload torque is exceed a new collapsible spacer must be installed. If maximum torque is reached prior to reaching the required preload, the collapsible spacer may have been damaged. Replace the collapsible spacer.

Drive pinion nut : 298 - 678 N-m (31 - 69Kg-m, 220 - 500 ft-lb)

4. Attach the RH and LH drive shafts. Refer to [FAX-8, "INSTALLATION"](#) .
5. Install the front propeller shaft. Refer to [PR-5, "INSTALLATION"](#) .

SIDE OIL SEALS

SIDE OIL SEALS

PF3:33142

Removal and Installation

EDS0034K

REMOVAL

1. Remove front final drive. Refer to [FFD-12, "REMOVAL"](#).
2. Remove differential side shaft and side flange using suitable tool.

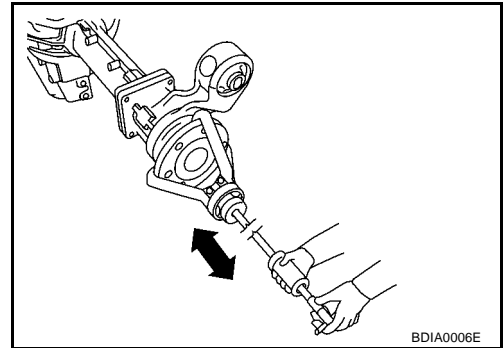

3. Place a small hole in seal case, using suitable punch or drill.

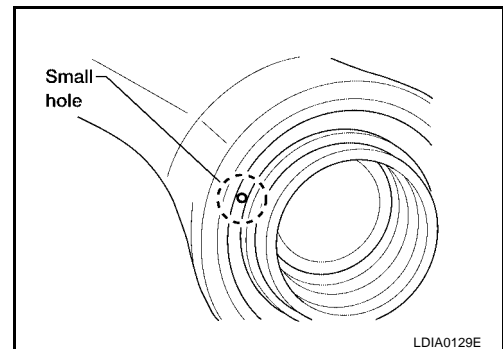

4. Assemble Tool as shown and remove seal.

Tool number : SP8P

5. Installation is in the reverse order of removal.

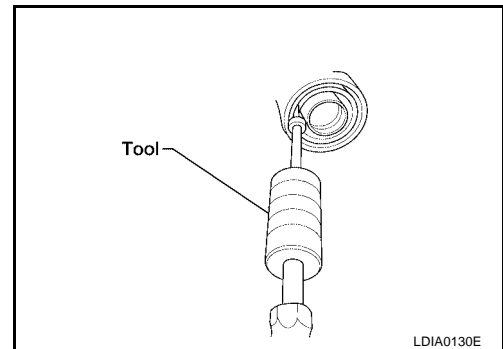

REAR COVER GASKET

PF3:38320

EDS0034L

REAR COVER GASKET

Removal and Installation

REMOVAL

1. Remove front final drive. Refer to [FFD-12, "REMOVAL"](#) .
2. Drain gear oil. Refer to [MA-26, "Changing Final Drive Oil"](#) .
3. Remove rear cover using Tool.

Tool number : KV10111100 (J-37228)

INSTALLATION

1. Apply 3.2mm (0.126 in) bead of sealant to the rear cover using Tool.
 - Use Genuine Silicone RTV sealant or equivalent. Refer to [GI-45, "RECOMMENDED CHEMICAL PRODUCTS AND SEALANTS"](#) .

Tool number : WS39930000 (—)

2. Install rear cover and tighten rear cover bolts in the order as shown [FFD-11, "INSTALLATION"](#) .
3. Fill final drive with recommended gear oil. Refer to [GI-45, "RECOMMENDED CHEMICAL PRODUCTS AND SEALANTS"](#) .
4. Install front final drive. Refer to [FFD-13, "INSTALLATION"](#) .

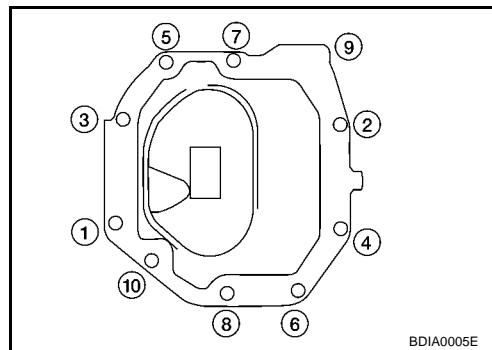
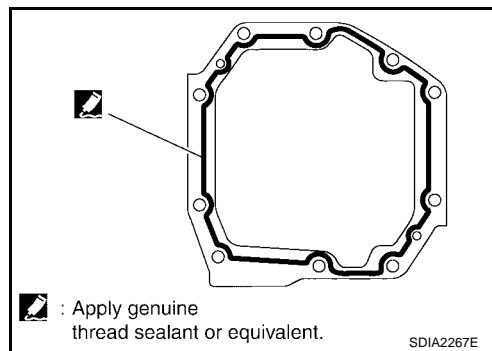

A

B

C

FFD

E

F

G

H

I

J

K

L

M

FRONT FINAL DRIVE ASSEMBLY

FRONT FINAL DRIVE ASSEMBLY

PF3:38500

Removal and Installation

EDS0034M

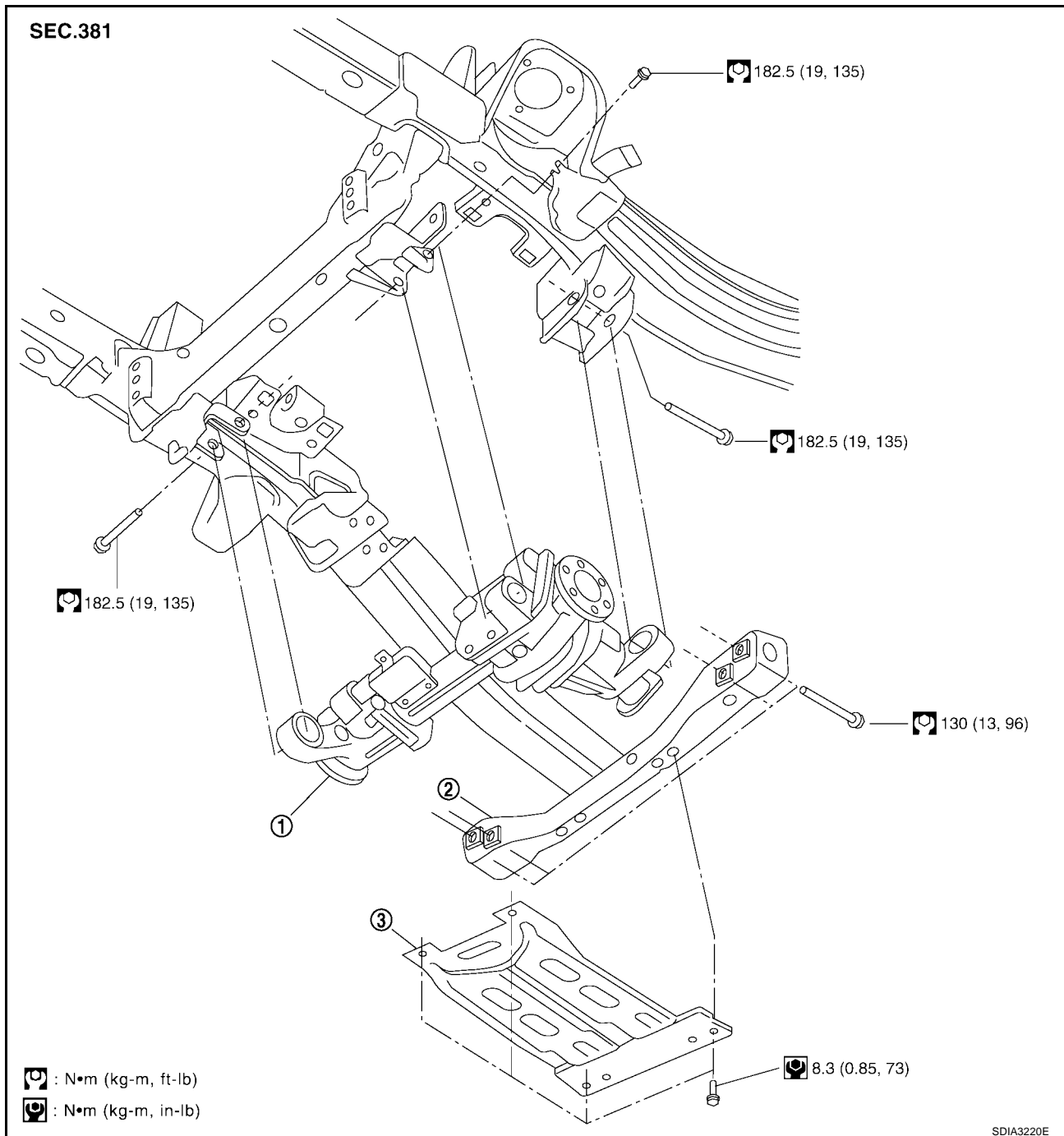

REMOVAL

1. Remove front propeller shaft. Refer to [PR-5, "REMOVAL"](#).

CAUTION:

Be careful not to damage spline, sleeve yoke and front oil seal when removing propeller shaft.

2. Separate LH and RH drive shafts from front final drive. Refer to [FAX-7, "REMOVAL"](#).
3. Remove front cross member.
4. Disconnect the vent hose.

FRONT FINAL DRIVE ASSEMBLY

5. Support the front final drive with suitable jack and remove the front final drive bolts. Carefully remove front final drive.

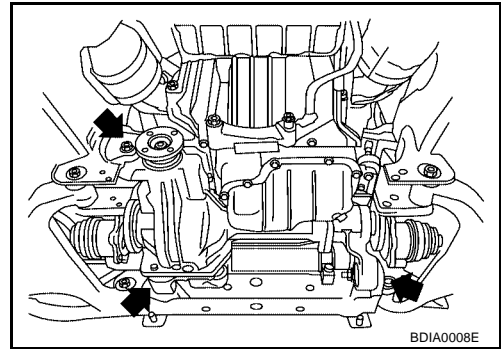

A

B

C

FFD

INSTALLATION

1. Install front final drive assembly.

Front final drive bolts : 182.5 N·m (19 kg-m, 135 ft-lb)

2. Connect the vent hose.
3. Install the front cross member.
4. Install LH and RH drive shaft. Refer to [FAX-8, "INSTALLATION"](#).
5. Install front propeller shaft. Refer to [PR-5, "INSTALLATION"](#).

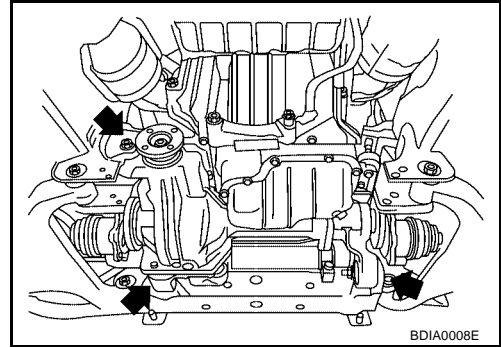

E

F

G

H

I

J

K

L

M

FRONT FINAL DRIVE ASSEMBLY

EDS0034N

Disassembly and Assembly COMPONENTS

SEC.380

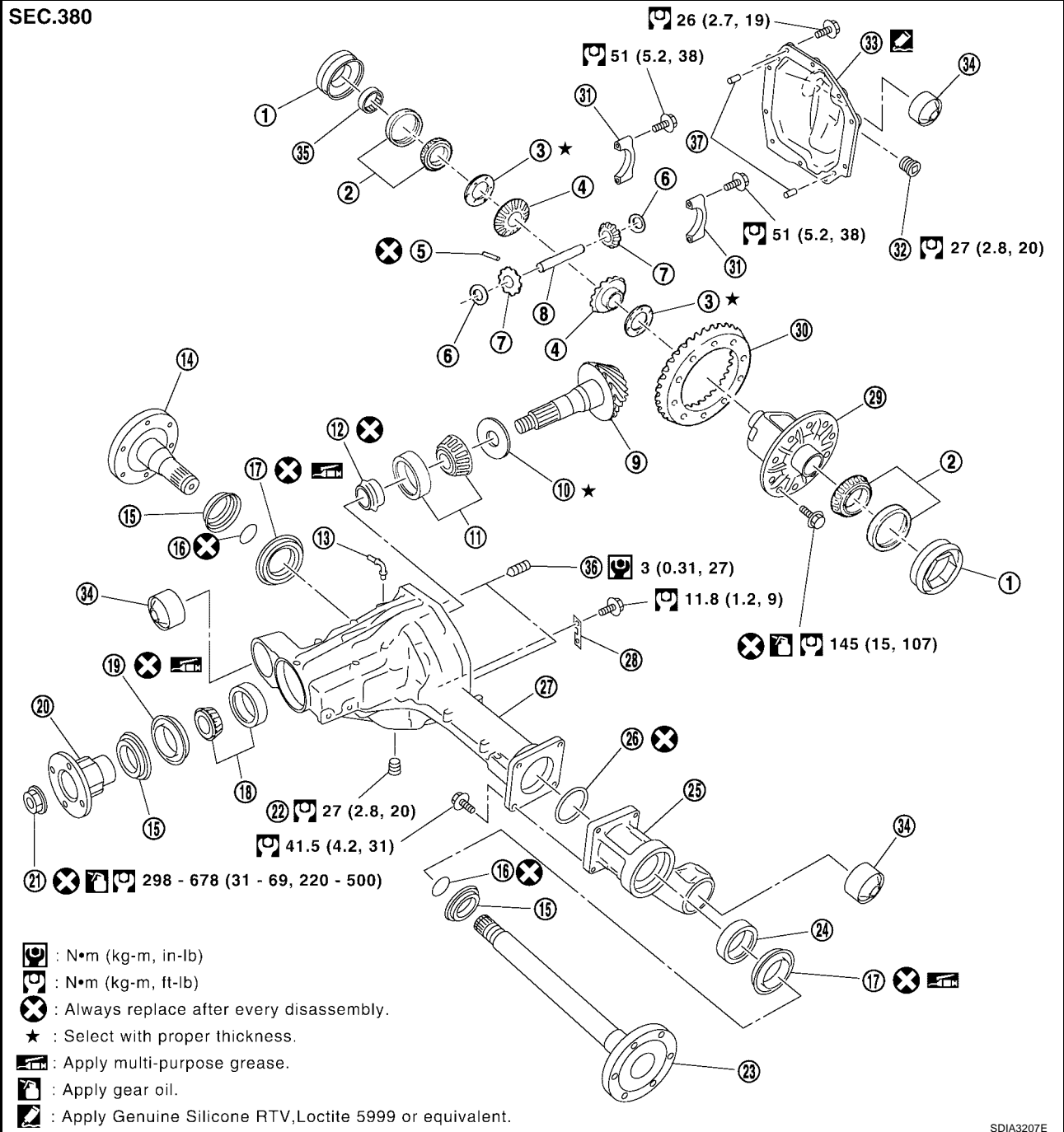

SDIA3207E

- | | | |
|--|-------------------------------|--------------------------------|
| 1. Side bearing adjust nut | 2. Side bearing | 3. Side gear thrust washer |
| 4. Side gear | 5. Lock pin | 6. Pinion mate thrust washer |
| 7. Pinion mate gear | 8. Pinion mate shaft | 9. Drive pinion |
| 10. Drive pinion height adjusting washer | 11. Drive pinion rear bearing | 12. Collapsible spacer |
| 13. Breather tube | 14. Differential side flange | 15. Dust shield |
| 16. Circular clip | 17. Side oil seal | 18. Drive pinion front bearing |
| 19. Front oil seal | 20. Companion flange | 21. Drive pinion nut |
| 22. Drain plug | 23. Differential side shaft | 24. Axle shaft bearing |
| 25. Extension tube | 26. O-ring | 27. Gear carrier |
| 28. Plate | 29. Differential case | 30. Drive gear |
| 31. Side bearing cap | 32. Filler plug | 33. Rear cover |

FRONT FINAL DRIVE ASSEMBLY

34. Bushing

35. Bearing

36. Screw

37. Dowel pin

ASSEMBLY INSPECTION AND ADJUSTMENT

- Before inspection and adjustment, drain gear oil.

Total Preload Torque

1. Rotate drive pinion back and forth 2 to 3 times to check for unusual noise and rotation malfunction.
2. Rotate drive pinion at least 20 times to check for smooth operation of the bearing.
3. Measure total preload with preload gauge.

Tool number : ST3127S000 (J-25765-A)

Total preload (with oil seal):

2.98 - 4.76 N-m (0.31 - 0.48 kg-m, 27 - 42 in-lb)

- If measured value is out of the specification, disassemble it to check and adjust each part. Adjust the pinion bearing preload and side bearing preload. Adjust the pinion bearing preload first, then adjust the side bearing preload.

When the preload torque is large

On pinion bearings: Replace the collapsible spacer.

On side bearings: Loosen the side bearing adjust nuts at the same force on each side.

When the preload is small

On pinion bearings: Tighten the drive pinion nut.

On side bearings: Tighten the side bearing adjust nuts at the same force on each side.

Tooth Contact

1. Remove rear cover. Refer to [FFD-11, "REMOVAL"](#).
2. Thoroughly clean drive gear and drive pinion teeth.
3. Lightly apply a mixture of powdered ferric oxide and oil or the equivalent. Apply it to 3 or 4 teeth of drive gear drive side.

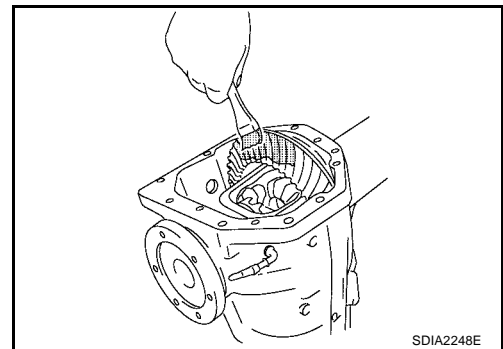
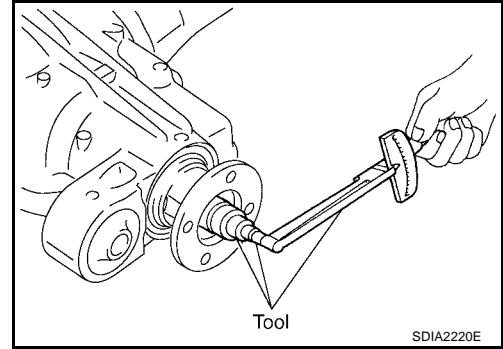

4. Rotate drive gear back and forth several times, check drive pinion gear to drive gear tooth contact.

CAUTION:

Check tooth contact on drive side and reverse side.

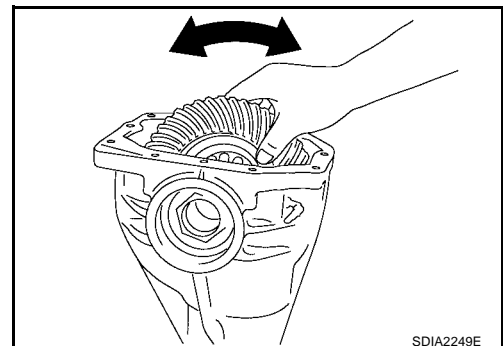

A
B
C
FFD
E
F
G
H
I
J
K
L
M

FRONT FINAL DRIVE ASSEMBLY

Usually the pattern will be correct if washers are correctly calculated and the backlash is correct. However, in rare cases, trial and error processes may be employed to obtain a correct pattern. The tooth pattern is the best indication of how well a differential has been set up.

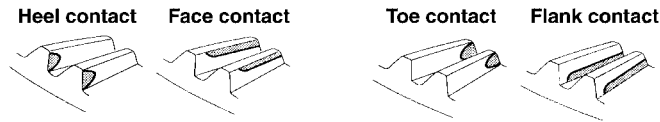

To correct, increase thickness of pinion height adjusting washer in order to bring drive pinion close to drive gear.

To correct, reduce thickness of pinion height adjusting washer in order to make drive pinion go away from drive gear.

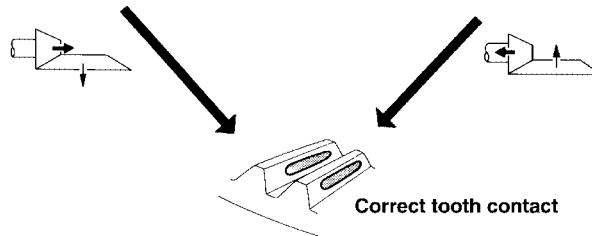

When adjustment is completed, be sure to wipe off completely the ferric oxide and oil or their equivalent.

SDIA1796E

Backlash

1. Remove carrier cover. Refer to [FFD-11, "REMOVAL"](#).
2. Fit a dial indicator to the drive gear face to measure the backlash.

Backlash: 0.13 - 0.18 mm (0.0051 - 0.0071 in)

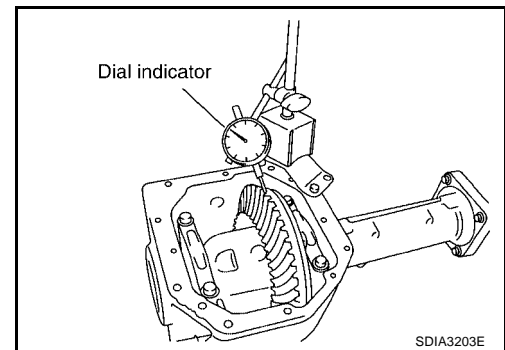

- If the backlash is outside of the specified value, use each side bearing adjust nut.

When the backlash is large:

Loosen adjust nut A and tighten adjust nut B.

When the backlash is small:

Loosen adjust nut B and tighten adjust nut A.

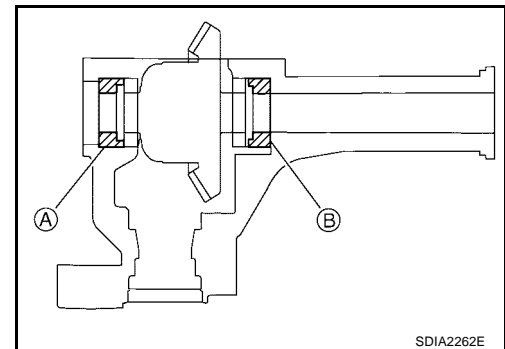

Companion Flange Runout

1. Fit a dial indicator onto the companion flange face (inner side of the propeller shaft mounting bolt holes).
2. Rotate companion flange to check for runout.

Runout limit: 0.10 mm (0.0039 in)

3. Fit a test indicator to the inner side of companion flange (socket diameter).

4. Rotate companion flange to check for runout.

Runout limit: 0.13 mm (0.0051 in)

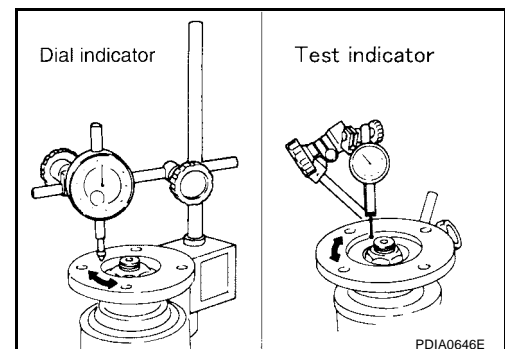

FRONT FINAL DRIVE ASSEMBLY

5. If the runout value is outside the runout limit, follow the procedure below to adjust.
 - a. Check for runout while changing the phase between companion flange and drive pinion by 90° step, and search for the position where the runout is the minimum.
 - b. If the runout value is still outside of the limit after the phase has been changed, possible cause will be an assembly malfunction of drive pinion and pinion bearing and malfunction of pinion bearing. Check for these items and repair if necessary.
 - c. If the runout value is still outside of the limit after the check and repair, replace companion flange.

DISASSEMBLY

Differential Assembly

1. Drain gear oil, if necessary.
2. Remove differential side shaft with a soft hammer.

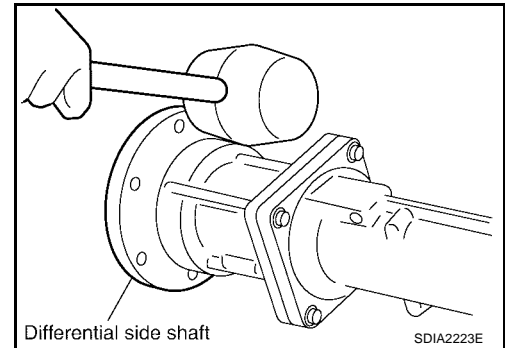

3. Remove differential side flange with a soft hammer.

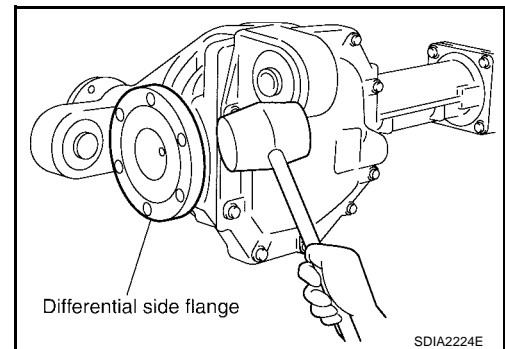

4. Remove extension tube and O-ring.

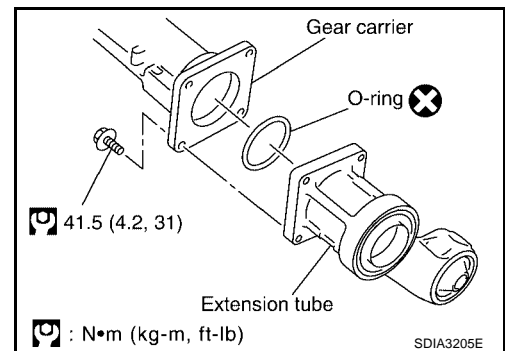

5. Place a small hole in seal case, using a suitable punch or drill.

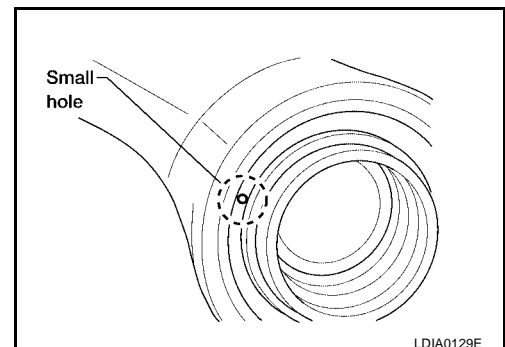

A
B
C

FFD

E

F

G

H

I

J

K

L

M

FRONT FINAL DRIVE ASSEMBLY

6. Install slide hammer tool as shown and remove seal.

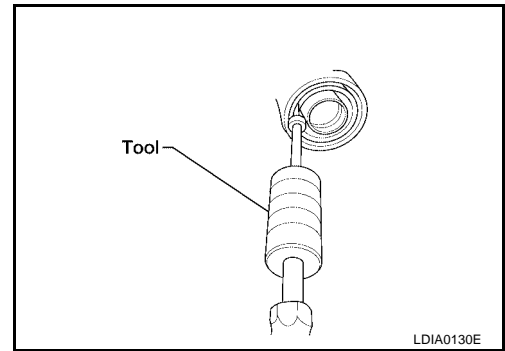

7. Remove rear cover from gear carrier.

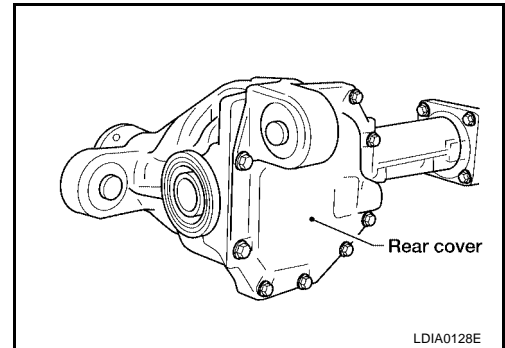

8. For proper reinstallation, paint matching mark on one side bearing cap.

CAUTION:

- For matching mark, use paint. Do not damage bearing caps and gear carrier.
- Bearing caps are line-board during manufacture. The matching marks are used to reinstall them in their original positions.

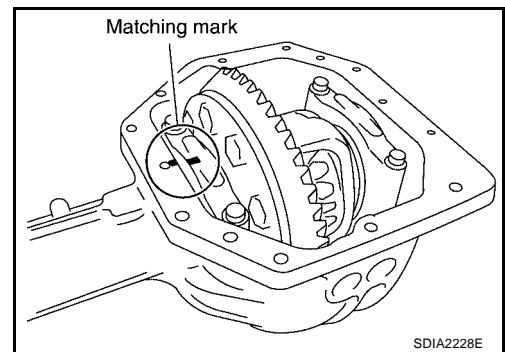

9. Remove side bearing caps.

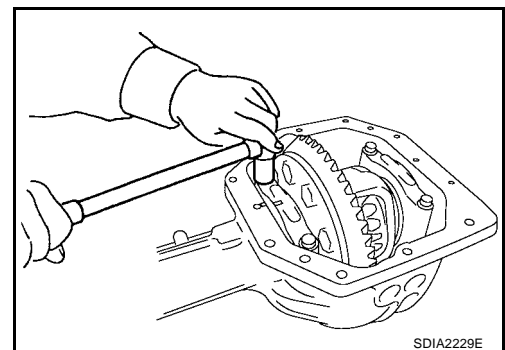

10. Remove side bearing adjust nuts.

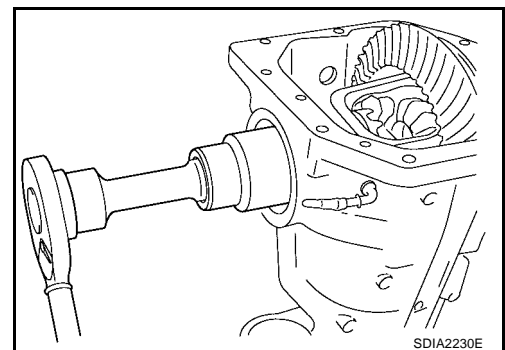

FRONT FINAL DRIVE ASSEMBLY

11. Keep the side bearing outer races together with inner race. Do not mix them up.

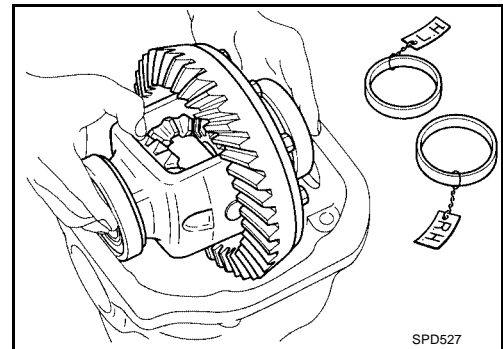

12. Remove side bearing inner race.
To prevent damage to bearing, engage puller jaws in groove.

Tool number **A: ST33081000 (—)**

B: ST30021000 (—)

CAUTION:

- To prevent damage to the side bearing and drive gear, place copper plates between these parts and vise.
- It is not necessary to remove side bearing except it is replaced.

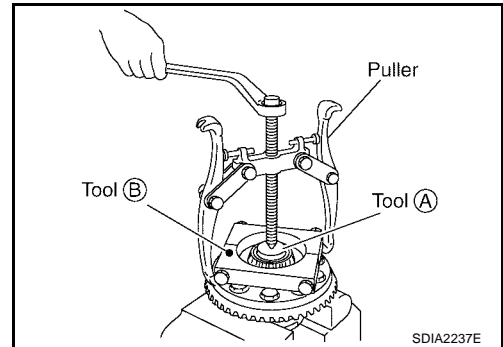

- Be careful not to confuse left-hand and right-hand parts. Keep bearing and bearing race for each side together.

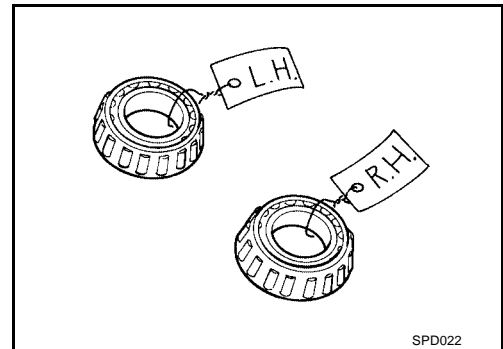

13. Loosen drive gear bolts in a crisscross fashion.
14. Tap drive gear off the differential case with a soft hammer.
- Tap evenly all around to keep the drive gear from bending.

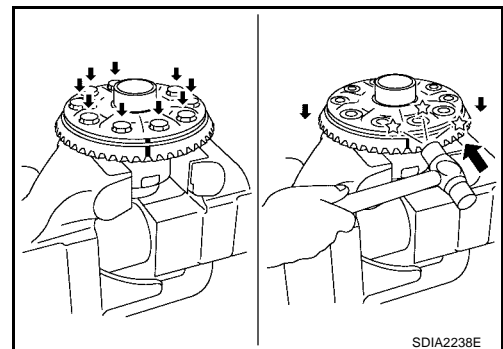

15. Drive out pinion mate shaft lock pin with suitable punch from drive gear side.

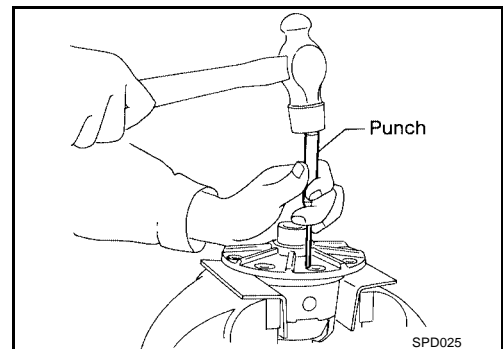

A
B
C
FFD

E
F
G
H
I
J
K
L
M

FRONT FINAL DRIVE ASSEMBLY

16. Remove the pinion mate shaft.

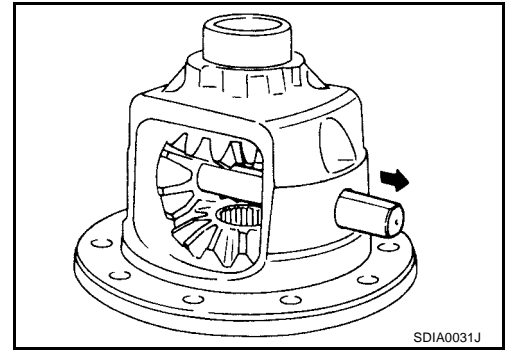

17. Turn the pinion mate gear, then remove the pinion mate gear, pinion mate thrust washer, side gear and side gear thrust washer from the differential case.

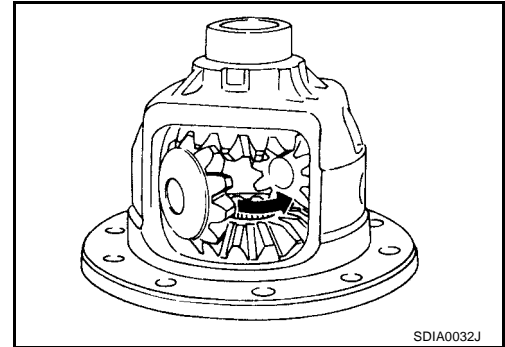

Drive Pinion Assembly

1. Remove differential assembly. Refer to [FFD-17, "Differential Assembly"](#).
2. Put matching marks on companion flange and drive pinion with paint.
3. Loosen drive pinion nut using Tool.

Tool number : KV38108300 (J-44195)

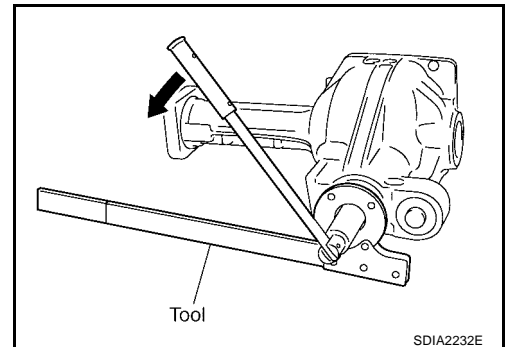

4. Remove companion flange using a suitable puller.

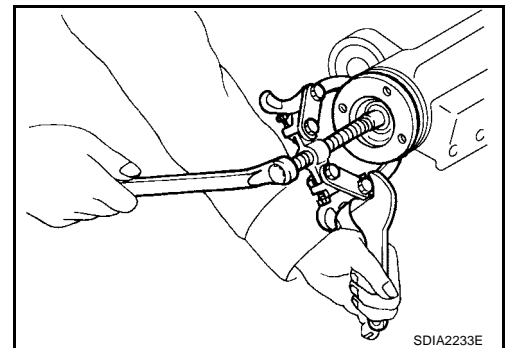

FRONT FINAL DRIVE ASSEMBLY

5. Remove drive pinion (together with rear bearing inner race, collapsible spacer.)
6. Remove pinion front bearing inner race.

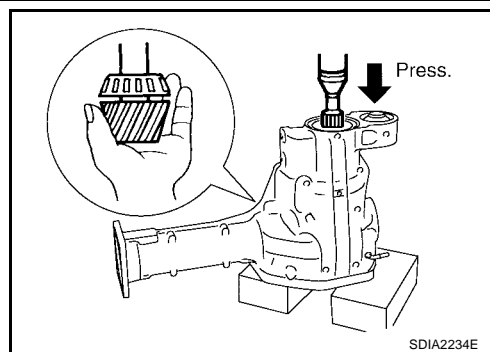

7. Place a small hole in seal case, using a suitable punch or drill.

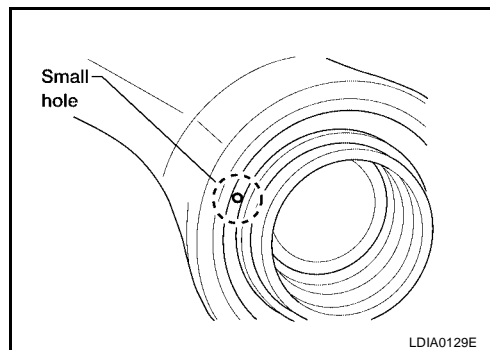

8. Install slide hammer tool as shown and remove seal.

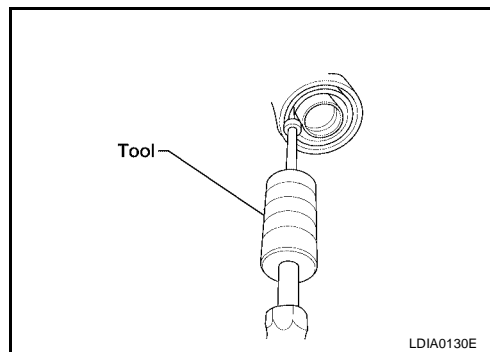

9. Turn nose of gear carrier down. Remove drive pinion front bearing outer race using Tool. Locate driver on back edge of outer race, then drive outer race out.

Tool number **A: C-4171**
 B: D-103

CAUTION:
Do not nick gear carrier.

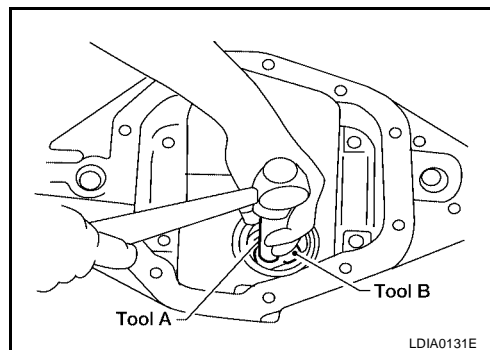

10. Turn nose of gear carrier up. Remove drive pinion rear bearing outer race using Tool. Locate driver on back edge of outer race, then drive outer race out.

Tool number **A: C-4171**
 B: C-4307

CAUTION:
Do not nick gear carrier.

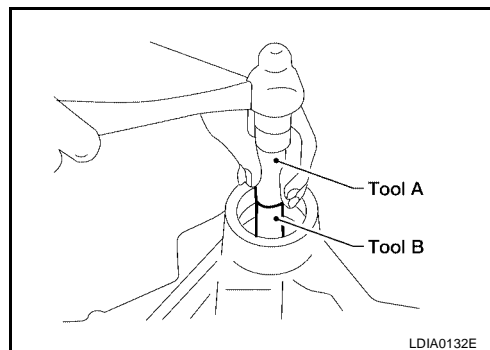

A
 B
 C
FFD
 E
 F
 G
 H
 I
 J
 K
 L
 M

FRONT FINAL DRIVE ASSEMBLY

11. Remove drive pinion rear bearing inner race and drive pinion height adjusting washer using Tool.

Tool number : ST30021000 (—)

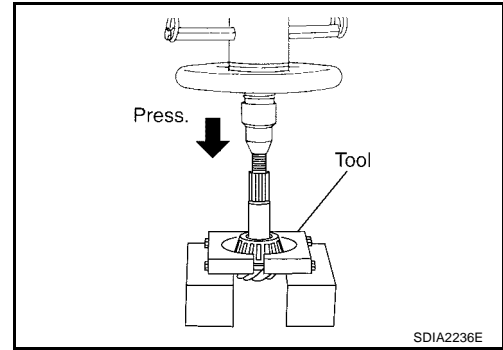

INSPECTION AFTER DISASSEMBLY

Clean up the disassembled parts. Then, inspect if the parts are worn or damaged. If so, follow the measures below.

Content	Conditions and Measures
Hypoid gear	<ul style="list-style-type: none"> ● If the gear teeth do not mesh or line-up correctly, determine the cause and adjust or replace as necessary. ● If the gears are worn, cracked, damaged, pitted or chipped (by friction) noticeably, replace with new drive gear and drive pinion as a set.
Bearing	<ul style="list-style-type: none"> ● If any chipped (by friction), pitted, worn, rusted or scratched mark, or unusual noise from the bearing is observed, replace as a bearing assembly (as a new set).
Side gear and Pinion mate gear	<ul style="list-style-type: none"> ● If any cracks or damage on the surface of the tooth is found, replace. ● If any worn or chipped mark on the contact sides of the thrust washer is found, replace.
Side gear thrust washer and pinion mate thrust washer	<ul style="list-style-type: none"> ● If it is chipped (by friction), damaged, or unusually worn, replace.
Oil seal	<ul style="list-style-type: none"> ● Whenever disassembled, replace. ● If wear, deterioration of adherence (sealing force lips), or damage is detected on the lips, replace them.
Differential case	<ul style="list-style-type: none"> ● If any wear or crack on the contact sides of the differential case is found, replace.
Companion flange	<ul style="list-style-type: none"> ● If any chipped mark (about 0.1 mm, 0.004 in) or other damage on the contact sides of the lips of the companion flange is found, replace.

FRONT FINAL DRIVE ASSEMBLY

ADJUSTMENT AND SELECTION OF ADJUSTING WASHERS

Differential Side Gear Clearance

- Assemble the differential parts if they are disassembled. Refer to [FFD-28, "Differential Assembly"](#).
- Place differential case straight up so that side gear to be measured comes upward.

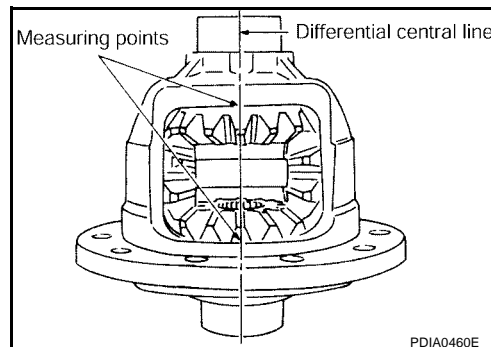

- Using feeler gauge, measure the clearance between side gear back and differential case at 3 different points, while rotating side gear. Average the 3 readings, and then measure the clearance of the other side as well.

Side gear back clearance specification
: 0.20 mm (0.0079 in) or less

CAUTION:

To prevent side gear from tilting, insert feeler gauges with the same thickness from both sides.

- If the back clearance is outside the specification, use a thicker/thinner side gear thrust washer to adjust. Refer to [FFD-32, "Side Gear Adjustment"](#).

When the back clearance is large:

Use a thicker thrust washer.

When the back clearance is small:

Use a thinner thrust washer.

CAUTION:

Select a side gear thrust washer for right and left individually.

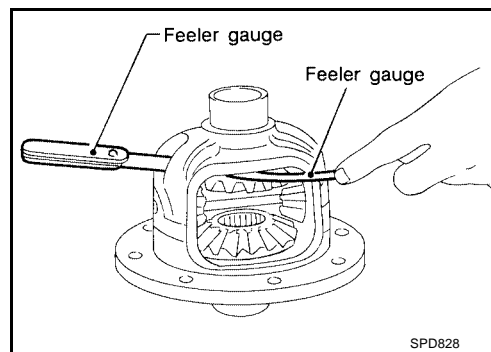

Pinion Gear Height

- Drive gear and pinions are supplied in matched sets only. Matching numbers on both pinion and drive gear are etched for verification. If a new gear set is being used, verify the numbers of each pinion gear and drive gear before proceeding with assembly.

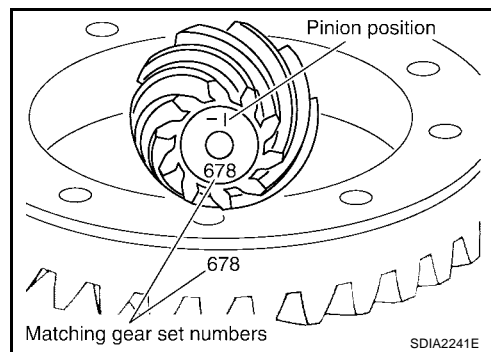

- The mounting distance from the centerline of the drive gear to the back face of the pinion gear for the M205 final drive is 103.5 mm (4.0748 inches). On the button end of each pinion, there is etched a plus (+) number, a minus (-) number, or a zero (0), which indicates the best running position for each particular gear set. This dimension is controlled by a selective shim between the inner pinion bearing race and pinion gear. For example: If a pinion is etched m+8 (+3), it would require 0.08 mm (0.003 inch) less shim than a pinion etched "0". This means decreasing shim thickness; increases the mounting distance of the pinion to 103.6 mm (4.0778 inches). If a pinion is etched m+8 (-3), it would require adding 0.08mm (0.003 inch) more to the shim than would be required if the pinion were etched "0". By adding 0.08 mm (0.003 inch), the mount-

A
B
C
FFD
E
F
G
H
I
J
K
L
M

FRONT FINAL DRIVE ASSEMBLY

ing distance of the pinion was decreased to 103.4 mm (4.0718 inches) which is just what a m-8 (-3) etching indicated.

- To change the pinion adjustment, use different shims which come in different thickness.
- Use the following tables as a guide for selecting the correct shim thickness to add or subtract from the old shim.

OLD PINION MARKING	NEW PINION MARKING (ENGLISH 0.000)								
	-4	-3	-2	-1	0	+1	+2	+3	+4
+4	+0.008	+0.007	+0.006	+0.005	+0.004	+0.003	+0.002	+0.001	0
+3	+0.007	+0.006	+0.005	+0.004	+0.003	+0.002	+0.001	0	-0.001
+2	+0.006	+0.005	+0.004	+0.003	+0.002	+0.001	0	-0.001	-0.002
+1	+0.005	+0.004	+0.003	+0.002	+0.001	0	-0.001	-0.002	-0.003
0	+0.004	+0.003	+0.002	+0.001	0	-0.001	-0.002	-0.003	-0.004
-1	+0.003	+0.002	+0.001	0	-0.001	-0.002	-0.003	-0.004	-0.005
-2	+0.002	+0.001	0	-0.001	-0.002	-0.003	-0.004	-0.005	-0.006
-3	+0.001	0	-0.001	-0.002	-0.003	-0.004	-0.005	-0.006	-0.007
-4	0	-0.001	-0.002	-0.003	-0.004	-0.005	-0.006	-0.007	-0.008

OLD PINION MARKING	NEW PINION MARKING (METRIC 0.00)								
	-10	-8	-5	-3	0	+3	+5	+8	+10
+10	+0.20	+0.18	+0.15	+0.13	+0.10	+0.08	+0.05	+0.02	0
+8	+0.18	+0.15	+0.13	+0.10	+0.08	+0.05	+0.02	0	-0.02
+5	+0.15	+0.13	+0.10	+0.08	+0.05	+0.02	0	-0.02	-0.05
+3	+0.13	+0.10	+0.08	+0.05	+0.02	0	-0.02	-0.05	-0.08
0	+0.10	+0.08	+0.05	+0.02	0	-0.02	-0.05	-0.08	-0.10
-3	+0.08	+0.05	+0.02	0	-0.02	-0.05	-0.08	-0.10	-0.13
-5	+0.05	+0.02	0	-0.02	-0.05	-0.08	-0.10	-0.13	-0.15
-8	+0.02	0	-0.02	-0.05	-0.08	-0.10	-0.13	-0.15	-0.18
-10	0	-0.02	-0.05	-0.08	-0.10	-0.13	-0.15	-0.18	-0.20

ASSEMBLY

Drive Pinion Assembly

1. Press-fit rear bearing outer race with Tools.

Tool number **A: ST30901000 (—)**
 B: KV40105230 (—)

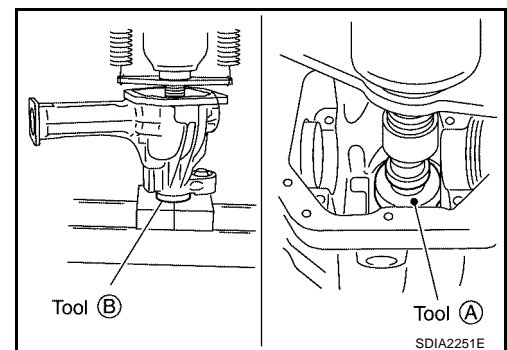

FRONT FINAL DRIVE ASSEMBLY

2. Press-fit front bearing outer race with Tools.

Tool number **A: ST35271000 (—)**
 B: KV40104810 (—)

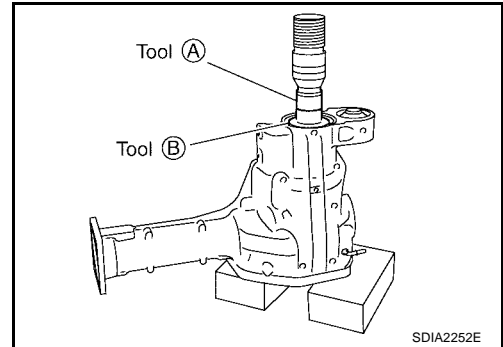

3. Temporarily install drive pinion height adjusting washer.

When hypoid gear set has been replaced

- Select drive pinion height adjusting washer. Refer to [FFD-33, "Drive Pinion Height Adjustment"](#).

When hypoid gear set has been reused

- Temporarily install the removed drive pinion height adjusting washer or same thickness washer to drive pinion.

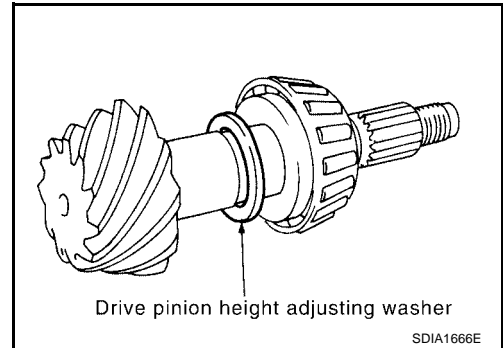

4. Install selected drive pinion height adjusting washer to drive pinion, and press-fit pinion rear bearing inner race in it, using a press and Tool.

Tool number **: C-4040**

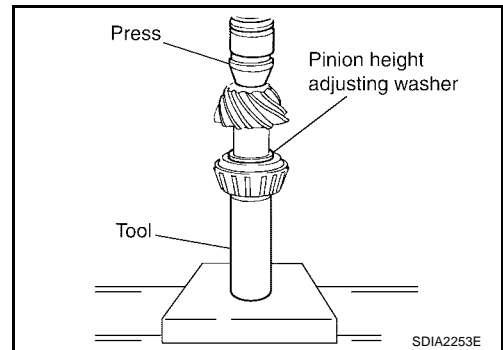

5. Place pinion front bearing inner race in gear carrier.

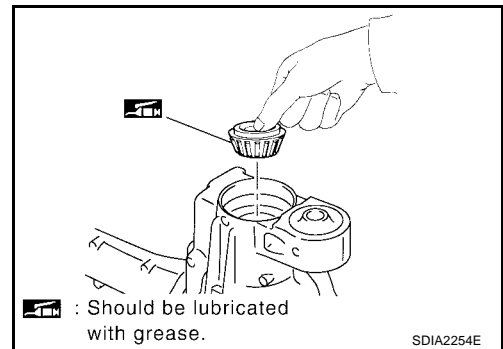

6. Apply multi-purpose grease to cavity at sealing lips of oil seal. Install front oil seal, using Tools.

Tool number **A: KV38100500 (J-25273)**
 B: KV38102200 (—)

7. Perform checking and adjusting the tooth contact and backlash of the hypoid gear following the procedure below.

- a. Assemble the drive pinion to the gear carrier.

CAUTION:

Do not assemble a collapsible spacer.

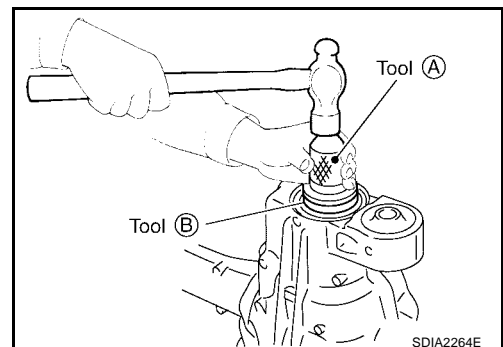

A
B
C
FFD
E
F
G
H
I
J
K
L
M

FRONT FINAL DRIVE ASSEMBLY

- b. Insert companion flange onto drive pinion. Tap the companion flange with a soft hammer until fully seated.

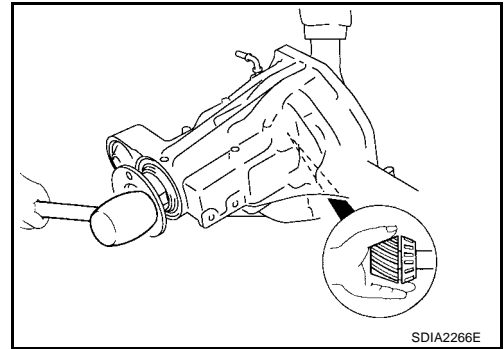

- c. Temporarily tighten removed drive pinion nut to drive pinion.

Tool number : KV38108300 (J-44195)

NOTE:

Use removed drive pinion nut only for the preload measurement.

- d. Rotate drive pinion at least 20 times to check for smooth operation of the bearing.

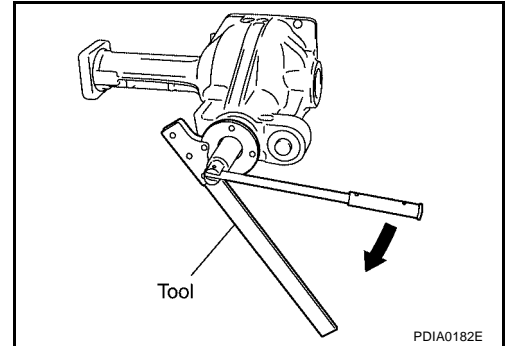

- e. Tighten to drive pinion nut, while adjust pinion bearing preload torque.

Tool number : ST3127S000 (J-25765-A)

Drive pinion nut tightening torque:

298 - 678 N-m (31 - 69 kg-m, 220 - 500 ft-lb)

Pinion bearing preload:

2.3 - 3.4 N-m (24 - 34 kg-cm, 21 - 30 in-lb)

CAUTION:

- Adjust to the lower limit of the drive pinion nut tightening torque first.
- Drive pinion nut is tightened with no collapsible spacer. Be careful not to overtighten it. While measuring the preload, tighten it by 5° to 10°.
- After adjustment, rotate drive pinion back and forth 2 to 3 times to check for unusual noise, rotation malfunction, and other malfunctions.

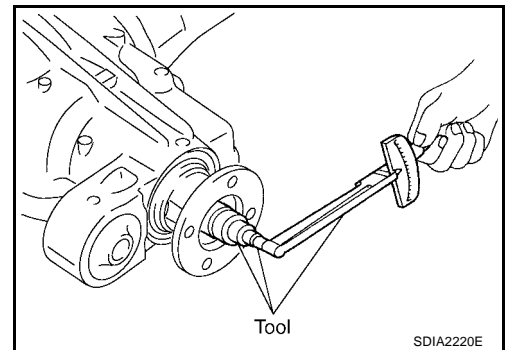

- f. Install side bearing adjust nut into gear carrier.
- g. Install differential case assembly with side bearing outer races into gear carrier.

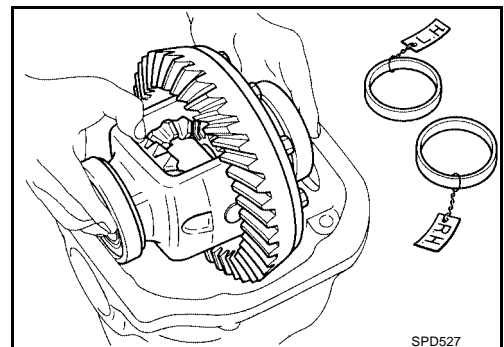

FRONT FINAL DRIVE ASSEMBLY

- h. Align mark on bearing cap with that on gear carrier and install bearing cap on gear carrier.
 - Do not tighten at this step. This allows further tightening of side bearing adjusters.
- i. Check and adjust the tooth contact and backlash. Refer to [FFD-15, "Tooth Contact"](#) and [FFD-16, "Backlash"](#).
- j. Remove differential case assembly.
- k. Remove companion flange.

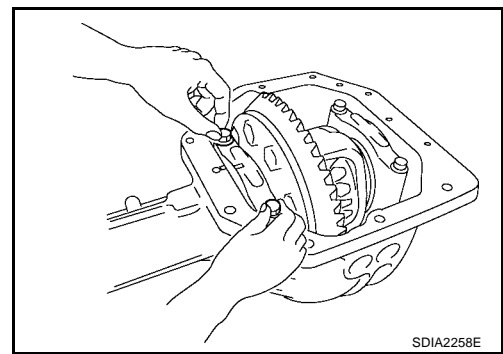

- l. Remove drive pinion (together with rear bearing inner race.)

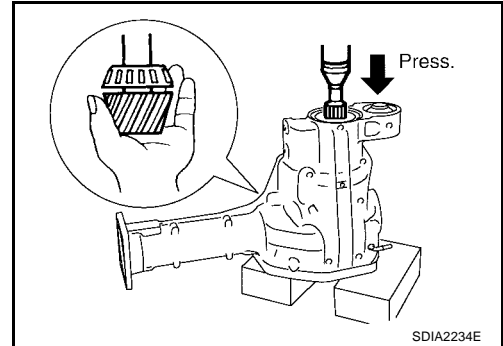

- 8. Assemble collapsible spacer to drive pinion.

CAUTION:
Do not reuse collapsible spacer.

- 9. Place collapsible spacer, drive pinion height adjusting washer and drive pinion in gear carrier.

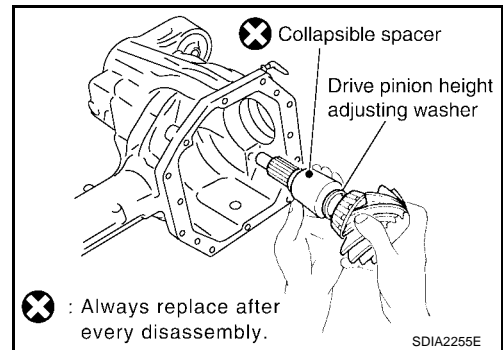

- 10. Insert companion flange onto drive pinion. Tap the companion flange with a soft hammer until fully seated.

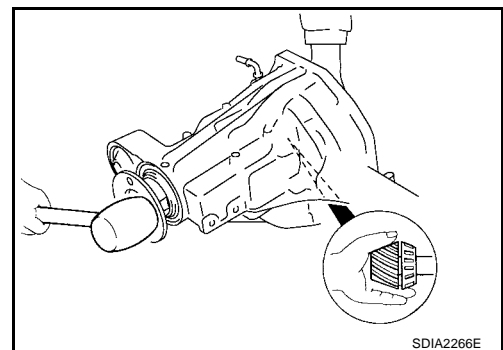

- 11. Apply anti-corrosive oil to the thread and seat of drive pinion nut, and temporarily tighten drive pinion nut to drive pinion.

Tool number : KV38108300 (J-44195)

CAUTION:
Do not reuse drive pinion nut.

- 12. Rotate drive pinion at least 20 times to check for smooth operation of the bearing.

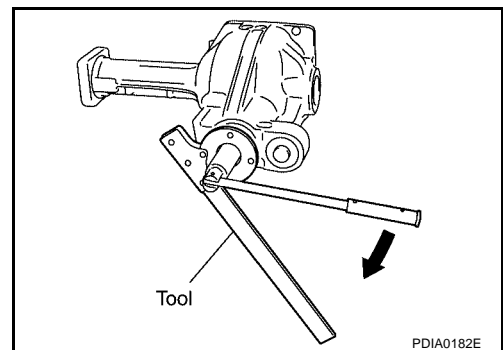

A
B
C
FFD

E
F
G

H
I
J

K
L
M

FRONT FINAL DRIVE ASSEMBLY

13. Tighten to drive pinon nut, while adjust pinion bearing preload torque.

Tool number : ST3127S000 (J-25765-A)

Drive pinion nut tightening torque:

298 - 678 N-m (31 - 69 kg-m, 220 - 500 ft-lb)

Pinion bearing preload:

2.3 - 3.4 N-m (24 - 34 kg-cm, 21 - 30 in-lb)

CAUTION:

- Adjust the lower limit of the drive pinion nut tightening torque first.
- If the preload torque exceeds the specified value, replace collapsible spacer and tighten it again to adjust. Never loosen drive pinion nut to adjust the preload torque.
- After adjustment, rotate drive pinion back and forth 2 to 3 times to check for unusual noise, rotation malfunction, and other malfunctions.

14. Install differential case assembly. Refer to [FFD-28, "Differential Assembly"](#) .

CAUTION:

Do not install rear cover yet.

15. Check and adjust tooth contact, drive gear to drive pinion backlash, and companion flange runout. Refer to [FFD-15, "Tooth Contact"](#) , [FFD-16, "Backlash"](#) , [FFD-16, "Companion Flange Runout"](#) .
Recheck above items. Readjust the above description, if necessary.
16. Check total preload torque. Refer to [FFD-15, "Total Preload Torque"](#) .
17. Install rear cover. Refer to [FFD-11, "INSTALLATION"](#) .

Differential Assembly

1. Apply gear oil to contact surfaces of each gear, thrust washers and differential case.
2. Install the removed thrust washer or same thickness washer to side gear.

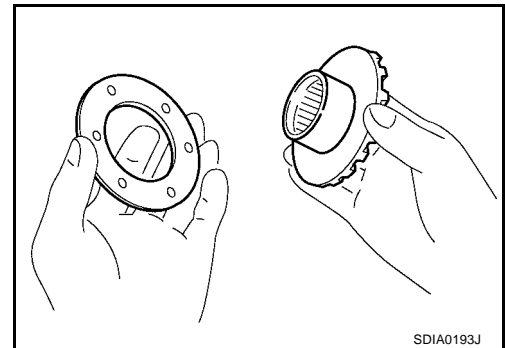

3. Install the side gears, thrust washers, pinion mate gears and thrust washers into differential case.

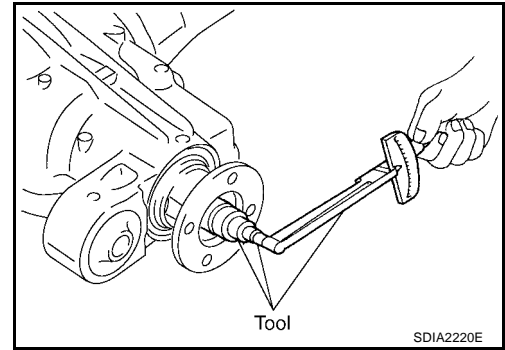
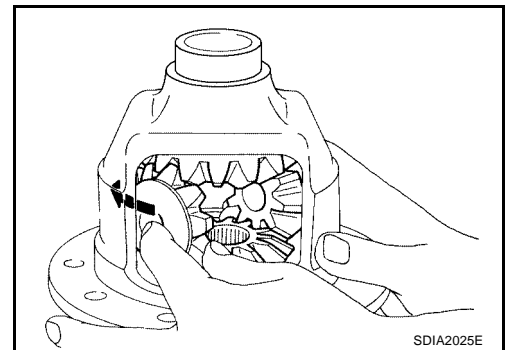

FRONT FINAL DRIVE ASSEMBLY

4. Install pinion mate shaft to differential case so that it meets lock pin holes.
5. Measure side gear end play. If necessary, select the appropriate side gear thrust washers. Refer to [FFD-23, "Differential Side Gear Clearance"](#).

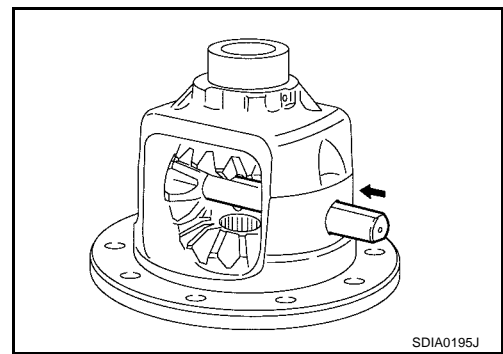

6. Drive a lock pin into pinion mate shaft, using a suitable punch. Make sure lock pin is flush with differential case.

CAUTION:

Do not reuse lock pin.

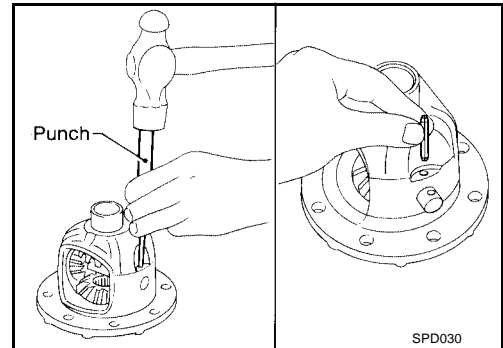

7. Apply gear oil to gear tooth surfaces and thrust surfaces and check to see they turn properly.
8. Install differential case assembly on drive gear.
 - Tighten bolts in a crisscross pattern, lightly tapping bolt head with a hammer.

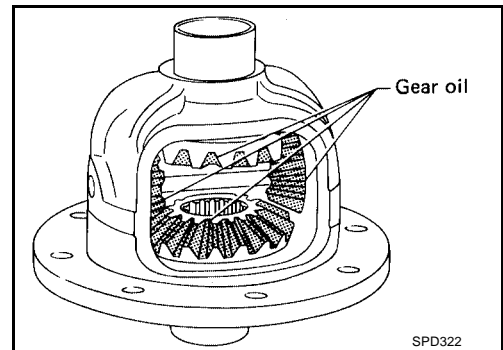

9. Place differential case on drive gear. Tighten bolts in a crisscross fashion.

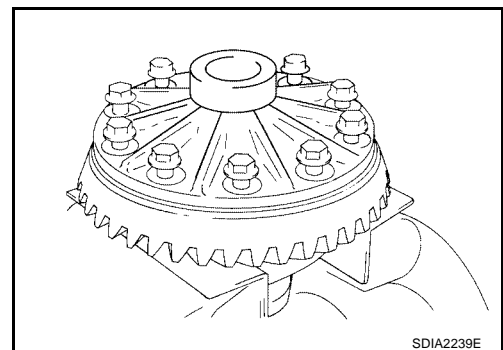

10. Press-fit side bearing inner race on differential case using Tools.

Tool number **A: KV38100300 (J-25523)**
 B: ST33081000 (—)

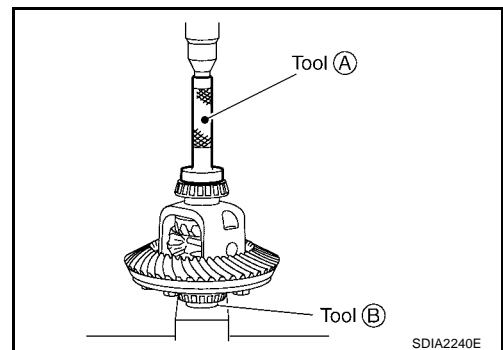

A
B
C
FFD
E
F
G
H
I
J
K
L
M

FRONT FINAL DRIVE ASSEMBLY

11. Install side bearing adjust nut into gear carrier.
12. Install differential case assembly with side bearing outer races into gear carrier.

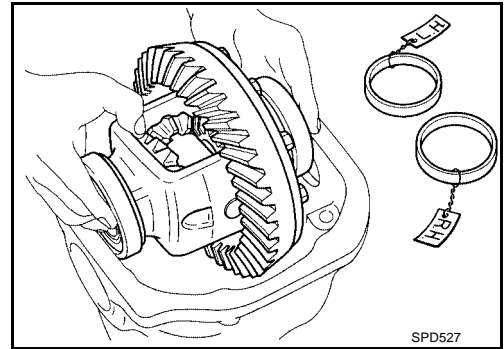

13. Align mark on bearing cap with that on gear carrier and install bearing cap on gear carrier.
 - Do not tighten at this step. This allows further tightening of side bearing adjusters.

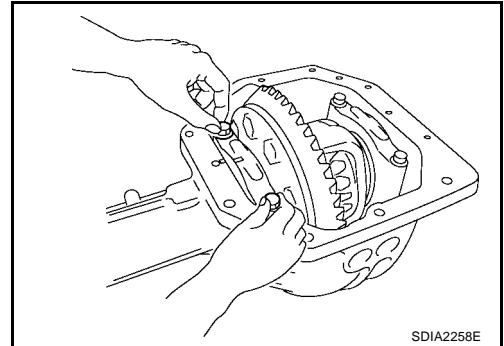

14. Tighten each side bearing adjust nuts alternately turning drive gear.
15. Check and adjust tooth contact and drive gear to drive pinion backlash. Refer to [FFD-15, "Tooth Contact"](#) , [FFD-16, "Backlash"](#) .
Recheck above items. Readjust the above description, if necessary.

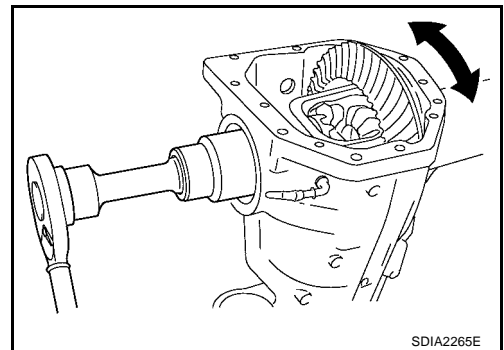

16. After adjusting tooth contact and drive gear to drive pinion backlash, fix adjuster with screws and tighten cap bolt to the specified torque. Refer to [FFD-14, "COMPONENTS"](#) .
17. Check total preload torque. Refer to [FFD-15, "Total Preload Torque"](#) .

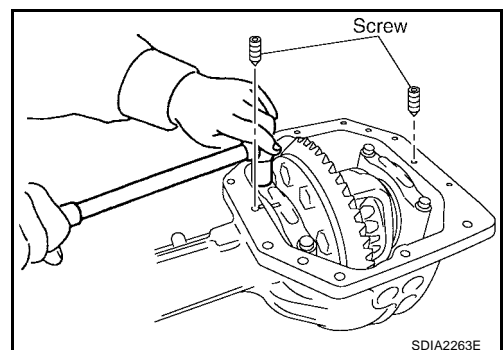

18. Apply recommended sealant to mating surface of rear cover.

CAUTION:

Remove old sealant adhering to mounting surfaces. Also remove any moisture, oil, or foreign material adhering to application and mounting surfaces.

19. Install rear cover on gear carrier and tighten bolts with the specified torque. Refer to [FFD-11, "INSTALLATION"](#) .
20. Apply multi-purpose grease to cavity at sealing lips of oil seal. Install side oil seal.

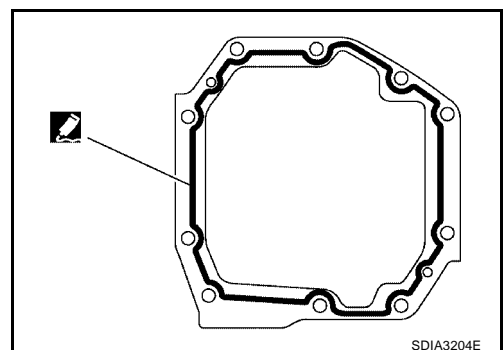

FRONT FINAL DRIVE ASSEMBLY

21. Install new O-ring and extension tube.

CAUTION:

If the extension tube is being replaced, install a new axle shaft bearing.

22. Install side shaft and side flange.

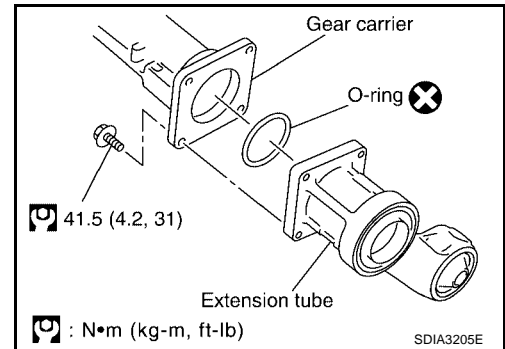

A
B
C

FFD

E
F
G
H
I
J
K
L
M

SERVICE DATA AND SPECIFICATIONS (SDS)

SERVICE DATA AND SPECIFICATIONS (SDS)

PFP:00030

General Specifications

EDS00340

Engine	VK56E	
Vehicle grade	All	
Front final drive	M205	
	2-pinion	
Gear ratio	2.937	3.357
Number of teeth (Drive gear/drive pinion)	47/16	47/14
Oil capacity (Approx.) ℓ (US pt, Imp pt)	1.6 (3-3/8 , 2-7/8)	

Side Gear Adjustment

EDS0034P

Side gear to pinion mate gear backlash (Clearance between side gear thrust washer and differential case) mm (in)		less than 0.20 (0.0079) or less
Available side gear thrust washers	Thickness mm (in)	
	Package part number*	
	0.76 (0.030)	38424 8S111
	0.79 (0.031)	
	0.81 (0.032)	
	0.84 (0.033)	
	0.87 (0.034)	
	0.89 (0.035)	38424 8S112
	0.91 (0.036)	
	0.94 (0.037)	
0.97 (0.038)		
0.99 (0.039)		

Total Preload Adjustment

EDS0034Q

Total preload N·m (Kg-m, in-lb)	Gear ratio 2.937 Type	Gear ratio 3.357 type
	3.09 - 4.87 (0.32 - 0.49, 28 - 43)	2.98 - 4.76 (0.31 - 0.48, 27 - 42)
Drive gear to drive pinion backlash mm (in)	0.13 - 0.18 (0.0051 - 0.0071)	

SERVICE DATA AND SPECIFICATIONS (SDS)

Drive Pinion Height Adjustment

EDS0034R

	Thickness mm (in)	Package part number*	
	Available drive pinion height adjust- ing washers	1.22 (0.048)	38154 8S111
1.24 (0.049)		B	
1.27 (0.050)			
1.30 (0.051)			
1.32 (0.052)			
1.35 (0.053)		38154 8S112	C
1.37 (0.054)			
1.40 (0.055)			
1.42 (0.056)			
1.45 (0.057)			
1.47 (0.058)		38154 8S113	
1.50 (0.059)			
1.52 (0.060)			
1.55 (0.061)			
1.57 (0.062)			
1.60 (0.063)		38154 8S114	F
1.63 (0.064)			
1.65 (0.065)			
1.68 (0.066)			
1.70 (0.067)			
1.73 (0.068)	38154 8S115		
1.75 (0.069)			
1.78 (0.070)			
1.80 (0.071)			
1.83 (0.072)			

FFD

*Always check with the Parts Department for the latest parts information.

I
J
K
L
M

SERVICE DATA AND SPECIFICATIONS (SDS)
