

A
B
C

WT

SECTION

ROAD WHEELS & TIRES

CONTENTS

<p>SERVICE INFORMATION 2</p> <p>PRECAUTIONS 2</p> <p style="padding-left: 20px;">Precaution for Supplemental Restraint System (SRS) "AIR BAG" and "SEAT BELT PRE-TENSIONER"2</p> <p style="padding-left: 20px;">Precaution Necessary for Steering Wheel Rotation After Battery Disconnect2</p> <p>PREPARATION 3</p> <p style="padding-left: 20px;">Special Service Tool3</p> <p style="padding-left: 20px;">Commercial Service Tool3</p> <p>NOISE, VIBRATION AND HARSHNESS (NVH) TROUBLESHOOTING 4</p> <p style="padding-left: 20px;">NVH Troubleshooting Chart4</p> <p>ROAD WHEEL 5</p> <p style="padding-left: 20px;">Inspection5</p> <p>ROAD WHEEL TIRE ASSEMBLY 6</p> <p style="padding-left: 20px;">Balancing Wheels6</p> <p style="padding-left: 20px;">Rotation8</p> <p>TIRE PRESSURE MONITORING SYSTEM 9</p> <p style="padding-left: 20px;">System Component9</p> <p style="padding-left: 20px;">System Description9</p> <p>CAN COMMUNICATION11</p> <p style="padding-left: 20px;">System Description 11</p> <p>TROUBLE DIAGNOSIS12</p> <p style="padding-left: 20px;">Wiring Diagram- T/WARN -12</p> <p style="padding-left: 20px;">Terminal and Reference Value for BCM12</p> <p style="padding-left: 20px;">ID Registration Procedure13</p>	<p style="padding-left: 20px;">Transmitter Wake Up Operation14</p> <p style="padding-left: 20px;">CONSULT-III Function (BCM)14</p> <p style="padding-left: 20px;">How to Perform Trouble Diagnosis for Quick and Accurate Repair15</p> <p style="padding-left: 20px;">Preliminary Check16</p> <p style="padding-left: 20px;">Self-Diagnosis (With CONSULT-III)17</p> <p style="padding-left: 20px;">Self-Diagnosis (Without CONSULT-III)18</p> <p>TROUBLE DIAGNOSIS FOR SELF-DIAGNOSTIC ITEMS20</p> <p style="padding-left: 20px;">Data from Transmitter Not Being Received20</p> <p style="padding-left: 20px;">Transmitter Malfunction20</p> <p style="padding-left: 20px;">Transmitter Pressure Malfunction21</p> <p style="padding-left: 20px;">Vehicle Speed Signal21</p> <p style="padding-left: 20px;">Vehicle Ignition Signal22</p> <p>TROUBLE DIAGNOSIS FOR SYMPTOMS23</p> <p style="padding-left: 20px;">Low Tire Pressure Warning Lamp Does Not Come On When Ignition Switch Is Turned On23</p> <p style="padding-left: 20px;">Low Tire Pressure Warning Lamp Stays On When Ignition Switch Is Turned On23</p> <p style="padding-left: 20px;">Low Tire Pressure Warning Lamp Flashes When Ignition Switch Is Turned On23</p> <p style="padding-left: 20px;">Hazard Warning Lamps Flash When Ignition Switch Is Turned On24</p> <p style="padding-left: 20px;">ID Registration Cannot Be Completed24</p> <p>REMOVAL AND INSTALLATION25</p> <p style="padding-left: 20px;">Transmitter (Pressure Sensor)25</p> <p>SERVICE DATA AND SPECIFICATIONS (SDS)27</p> <p style="padding-left: 20px;">Road Wheel27</p> <p style="padding-left: 20px;">Tire27</p>
---	--

WT

F
G
H
I
J
K
L
M
N
O
P

PRECAUTIONS

< SERVICE INFORMATION >

SERVICE INFORMATION

PRECAUTIONS

Precaution for Supplemental Restraint System (SRS) "AIR BAG" and "SEAT BELT PRE-TENSIONER"

INFOID:000000004783754

The Supplemental Restraint System such as "AIR BAG" and "SEAT BELT PRE-TENSIONER", used along with a front seat belt, helps to reduce the risk or severity of injury to the driver and front passenger for certain types of collision. This system includes seat belt switch inputs and dual stage front air bag modules. The SRS system uses the seat belt switches to determine the front air bag deployment, and may only deploy one front air bag, depending on the severity of a collision and whether the front occupants are belted or unbelted. Information necessary to service the system safely is included in the SRS and SB section of this Service Manual.

WARNING:

- To avoid rendering the SRS inoperative, which could increase the risk of personal injury or death in the event of a collision which would result in air bag inflation, all maintenance must be performed by an authorized NISSAN/INFINITI dealer.
- Improper maintenance, including incorrect removal and installation of the SRS can lead to personal injury caused by unintentional activation of the system. For removal of Spiral Cable and Air Bag Module, see the SRS section.
- Do not use electrical test equipment on any circuit related to the SRS unless instructed to in this Service Manual. SRS wiring harnesses can be identified by yellow and/or orange harnesses or harness connectors.
- When working near the Airbag Diagnosis Sensor Unit or other Airbag System sensors with the Ignition ON or engine running, DO NOT use air or electric power tools or strike near the sensor(s) with a hammer. Heavy vibration could activate the sensor(s) and deploy the air bag(s), possibly causing serious injury.
- When using air or electric power tools or hammers, always switch the Ignition OFF, disconnect the battery, and wait at least 3 minutes before performing any service.

Precaution Necessary for Steering Wheel Rotation After Battery Disconnect

INFOID:000000004732590

NOTE:

- This Procedure is applied only to models with Intelligent Key system and NATS (NISSAN ANTI-THEFT SYSTEM).
- Remove and install all control units after disconnecting both battery cables with the ignition knob in the "LOCK" position.
- Always use CONSULT-III to perform self-diagnosis as a part of each function inspection after finishing work. If DTC is detected, perform trouble diagnosis according to self-diagnostic results.

For models equipped with the Intelligent Key system and NATS, an electrically controlled steering lock mechanism is adopted on the key cylinder.

For this reason, if the battery is disconnected or if the battery is discharged, the steering wheel will lock and steering wheel rotation will become impossible.

If steering wheel rotation is required when battery power is interrupted, follow the procedure below before starting the repair operation.

OPERATION PROCEDURE

1. Connect both battery cables.

NOTE:

Supply power using jumper cables if battery is discharged.

2. Use the Intelligent Key or mechanical key to turn the ignition switch to the "ACC" position. At this time, the steering lock will be released.
3. Disconnect both battery cables. The steering lock will remain released and the steering wheel can be rotated.
4. Perform the necessary repair operation.
5. When the repair work is completed, return the ignition switch to the "LOCK" position before connecting the battery cables. (At this time, the steering lock mechanism will engage.)
6. Perform a self-diagnosis check of all control units using CONSULT-III.

PREPARATION

< SERVICE INFORMATION >

PREPARATION

Special Service Tool

INFOID:000000004407375

The actual shapes of Kent-Moore tools may differ from those of special service tools illustrated here.

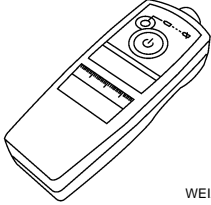
Tool number (Kent-Moore No.) Tool name	Description
KV991B1000 (J-45295) Transmitter activation tool  WEIA0144E	<ul style="list-style-type: none"> • Transmitter wake up operation • ID registration procedure

A

B

C

D

WT

Commercial Service Tool

INFOID:000000004407376

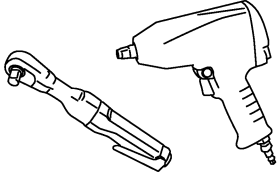
Tool name	Description
Power tool  PBIC0190E	Removing wheel nuts

F

G

H

I

J

K

L

M

N

O

P

NOISE, VIBRATION AND HARSHNESS (NVH) TROUBLESHOOTING

< SERVICE INFORMATION >

NOISE, VIBRATION AND HARSHNESS (NVH) TROUBLESHOOTING

NVH Troubleshooting Chart

INFOID:000000004407377

Use the chart below to help you find the cause of the symptom. If necessary, repair or replace these parts.

Symptom		Possible cause and SUSPECTED PARTS	Reference page															
			—	WT-5	WT-6	WT-27	—	—	—	WT-27	FAX-5. "NVH Troubleshooting Chart", FSU-6. "NVH Troubleshooting Chart"	RAX-5. "NVH Troubleshooting Chart", RSU-4. "NVH Troubleshooting Chart"	Refer to TIRES in this chart	Refer to ROAD WHEEL in this chart	FAX-5. "NVH Troubleshooting Chart"	BR-4. "NVH Troubleshooting Chart"	PS-6. "NVH Troubleshooting Chart"	
Noise	TIRES	Improper installation, looseness	×	×	×	×	×	×	×	×	×	×	×	×	×	×	×	×
		Out-of-round	×	×	×	×	×	×	×	×	×	×	×	×	×	×	×	×
		Imbalance	×	×	×	×	×	×	×	×	×	×	×	×	×	×	×	×
		Incorrect tire pressure	×	×	×	×	×	×	×	×	×	×	×	×	×	×	×	×
	ROAD WHEEL	Uneven tire wear	×	×	×	×	×	×	×	×	×	×	×	×	×	×	×	×
		Deformation or damage	×	×	×	×	×	×	×	×	×	×	×	×	×	×	×	×
		Non-uniformity	×	×	×	×	×	×	×	×	×	×	×	×	×	×	×	×
		Incorrect tire size	×	×	×	×	×	×	×	×	×	×	×	×	×	×	×	×
Shake	FRONT AXLE AND FRONT SUSPENSION	×	×	×	×	×	×	×	×	×	×	×	×	×	×	×	×	
	REAR AXLE AND REAR SUSPENSION	×	×	×	×	×	×	×	×	×	×	×	×	×	×	×	×	
	TIRES	×	×	×	×	×	×	×	×	×	×	×	×	×	×	×	×	
	ROAD WHEELS	×	×	×	×	×	×	×	×	×	×	×	×	×	×	×	×	
Vibration	DRIVE SHAFT	×	×	×	×	×	×	×	×	×	×	×	×	×	×	×	×	
	BRAKE	×	×	×	×	×	×	×	×	×	×	×	×	×	×	×	×	
	STEERING	×	×	×	×	×	×	×	×	×	×	×	×	×	×	×	×	
	Poor quality ride or handling	×	×	×	×	×	×	×	×	×	×	×	×	×	×	×	×	

×: Applicable

ROAD WHEEL

< SERVICE INFORMATION >

ROAD WHEEL

Inspection

INFOID:000000004407378

ALUMINUM WHEEL

1. Check tires for wear and improper inflation.
2. Check wheels for deformation, cracks and other damage. If deformed, remove wheel and check wheel runout.
 - a. Remove tire from aluminum wheel and mount on a tire balance machine.
 - b. Set dial indicator as shown.

Wheel runout (Dial indicator value) : Refer to [WT-27, "Road Wheel"](#).

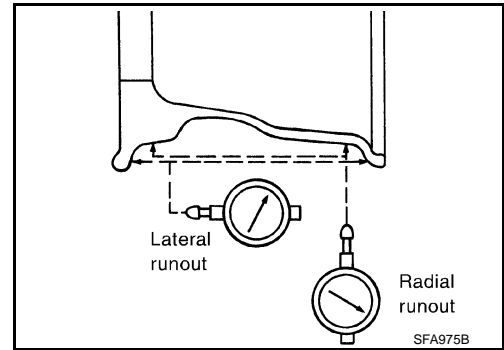

STEEL WHEEL

1. Check tires for wear and improper inflation.
2. Check wheels for deformation, cracks and other damage. If deformed, remove wheel and check wheel runout.
 - a. Remove tire from steel wheel and mount on a tire balance machine.
 - b. Set two dial indicators as shown.
 - c. Set each dial indicator to 0.
 - d. Rotate wheel and check dial indicators at several points around the circumference of the wheel.
 - e. Calculate runout at each point as shown.

$$\text{Radial runout} = (A+B)/2$$

$$\text{Lateral runout} = (C+D)/2$$

- f. Select maximum positive runout value and the maximum negative value.

Add the two values to determine total runout. In case a positive or negative value is not available, use the maximum value (negative or positive) for total runout. If the total runout value exceeds the limit, replace steel wheel.

Wheel runout : Refer to [WT-27, "Road Wheel"](#).

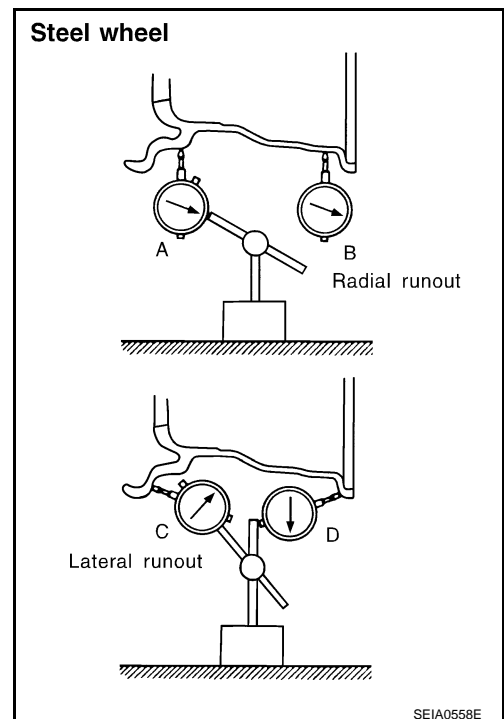

ROAD WHEEL TIRE ASSEMBLY

< SERVICE INFORMATION >

ROAD WHEEL TIRE ASSEMBLY

Balancing Wheels

INFOID:000000004407379

REMOVAL

1. Remove inner and outer balance weights from the wheel.

CAUTION:

Be careful not to scratch the wheel during removal procedures.

2. Using releasing agent, remove double-faced adhesive tape from the wheel.

CAUTION:

- **Be careful not to scratch the wheel during removal.**
- **After removing double-faced adhesive tape, wipe clean traces of releasing agent from the wheel.**

WHEEL BALANCE ADJUSTMENT

NOTE:

If a tire balance machine has adhesion balance weight mode settings and drive-in weight mode setting, select and adjust a drive-in weight mode suitable for wheels.

1. Set wheel on wheel balancer using the center hole as a guide. Start the tire balance machine.

2. When inner and outer unbalance values are shown on the wheel balancer indicator, multiply outer unbalance value by 1.6 to determine balance weight that should be used. Select the outer balance weight with a value closest to the calculated value and install it to the designated outer position of, or at the designated angle in relation to the road wheel.

CAUTION:

- **Do not install the inner balance weight before installing the outer balance weight.**
- **Before installing the balance weight, be sure to clean the mating surface of the wheel.**

Indicated unbalance value $\times 5/3$ = balance weight to be installed

Calculation example:

23 g (0.81 oz.) $\times 5/3$ = 38.33 g (1.35 oz.) = 40 g (1.41 oz.) balance weight (closer to calculated balance weight value)

Note that balance weight value must be closer to the calculated balance weight value.

Example:

37.4 g = 35 g (1.23 oz.)

37.5 g = 40 g (1.41 oz.)

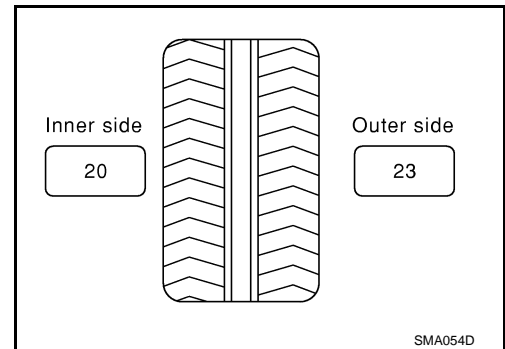

ROAD WHEEL TIRE ASSEMBLY

< SERVICE INFORMATION >

- Install balance weight in the position shown.
- When installing balance weight to wheels, set it into the grooved area on the inner wall of the wheel as shown so that the balance weight center is aligned with the wheel balancer indication position (angle).

CAUTION:

- Always use genuine Nissan adhesion balance weights.
- Balance weights are not reusable; always replace with new ones.
- Do not install more than three sheets of balance weight.

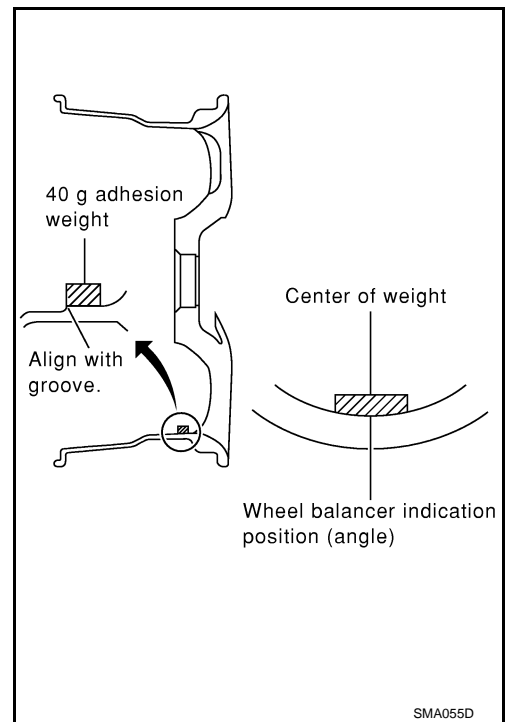

- If calculated balance weight value exceeds 50 g (1.76 oz.), install two balance weight sheets in line with each other as shown.

CAUTION:

Do not install one balance weight sheet on top of another.

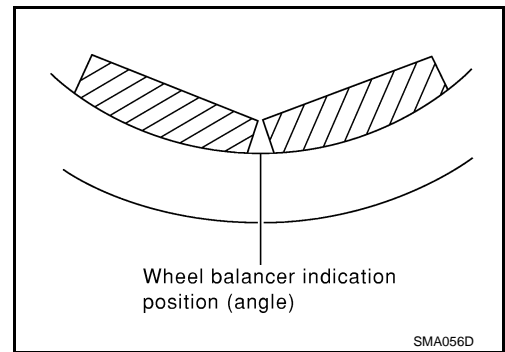

- Start wheel balancer again.
- Install drive-in balance weight on inner side of road wheel in the wheel balancer indication position (angle).

CAUTION:

Do not install more than two balance weights.

- Start wheel balancer. Make sure that inner and outer residual unbalance values are 5 g (0.18 oz.) each or below.
 - If either residual unbalance value exceeds 5 g (0.18 oz.), repeat installation procedures.

Wheel Balance (Maximum Allowable Unbalance)

Maximum allowable unbalance	Dynamic (At rim flange)	5 g (0.18 oz.) (one side)
	Static	10 g (0.35 oz.)

ROAD WHEEL TIRE ASSEMBLY

< SERVICE INFORMATION >

Rotation

INFOID:000000004407380

- Follow the maintenance schedule for tire rotation service intervals. Refer to [MA-8](#).
- ←: Front
- Do not include the T-type spare tire when rotating tires.
- Tighten wheel nuts to specification.

CAUTION:

- **When installing wheels, tighten them diagonally by dividing the work two to three times in order to prevent the wheels from developing any distortion.**
- **Be careful not to tighten wheel nut at torque exceeding the specification to prevent damage of disc rotor.**

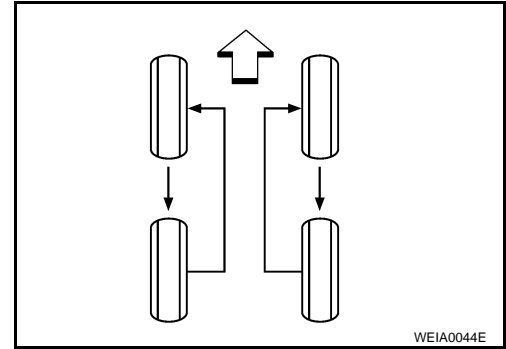

Wheel nut : 113 N·m (12 kg·m, 83 ft·lb)

- After rotating the tires, adjust the tire pressure. Refer to [WT-27. "Tire"](#).

TIRE PRESSURE MONITORING SYSTEM

< SERVICE INFORMATION >

TIRE PRESSURE MONITORING SYSTEM

System Component

INFOID:000000004407381

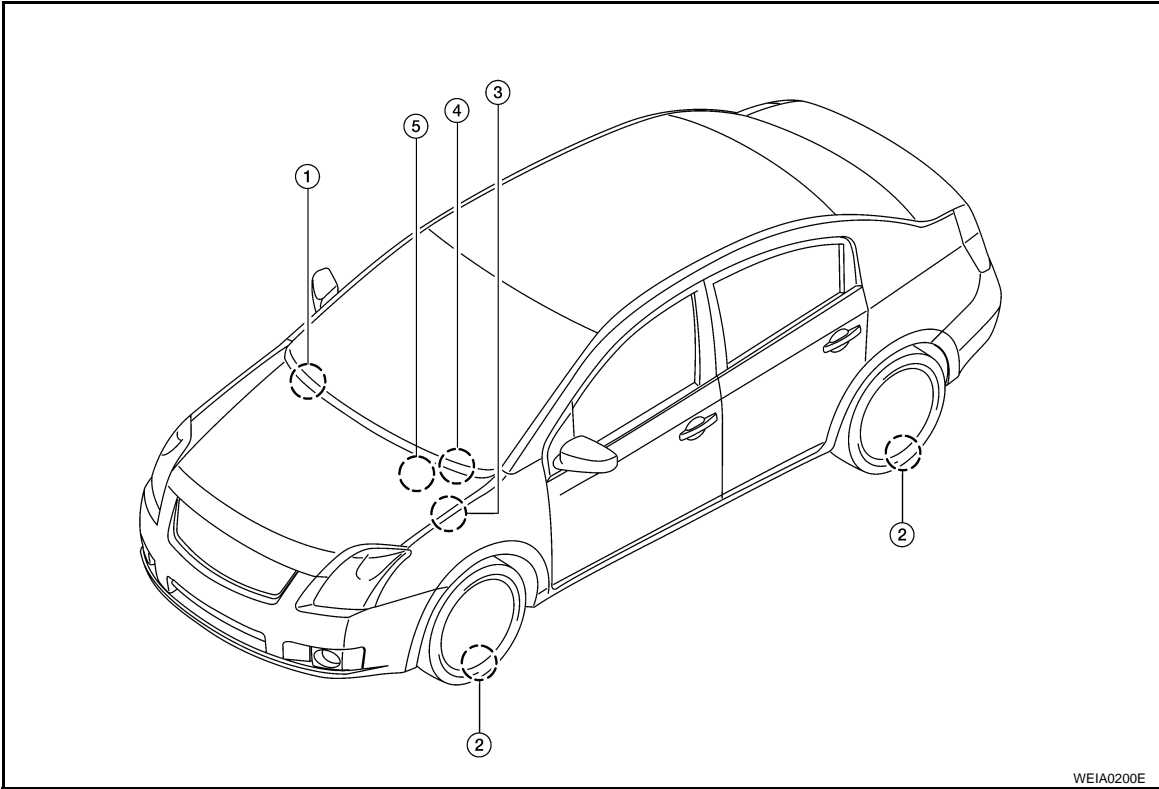

WEIA0200E

- | | | |
|---|--------------------|---|
| 1. Remote keyless entry receiver
M15 | 2. Transmitters | 3. Tire pressure warning check connector
M39 |
| 4. Combination meter
M24 | 5. BCM
M18, M20 | |

System Description

INFOID:000000004407382

BODY CONTROL MODULE (BCM)

The BCM is shown with the instrument panel removed. The BCM reads the air pressure signal received by the remote keyless entry receiver, and controls the low tire pressure warning lamp as shown below. It also has a self-diagnosis function to detect a system malfunction.

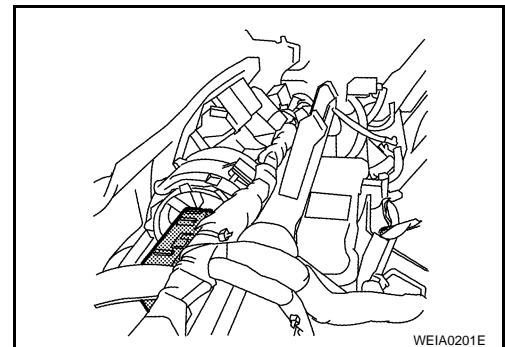

WEIA0201E

Condition	Low tire pressure warning lamp
System normal	On for 1 second after ignition ON
Tire less than 182 kPa (1.82 kg/cm ² , 26.5 psi) [Flat tire]	ON
Tire pressure monitoring system malfunction	After key ON, flashes once per second for 1 minute, then stays ON

TRANSMITTER

A
B
C
D
WT
F
G
H
I
J
K
L
M
N
O
P

TIRE PRESSURE MONITORING SYSTEM

< SERVICE INFORMATION >

A sensor-transmitter integrated with a valve is installed in each wheel, and transmits a detected air pressure signal in the form of a radio wave. The radio signal is received by the remote keyless entry receiver.

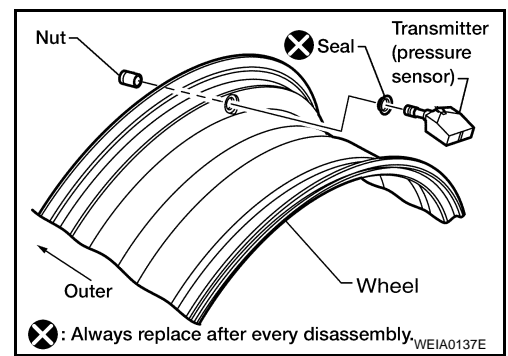

REMOTE KEYLESS ENTRY RECEIVER

The remote keyless entry receiver (without Intelligent Key (A), or with Intelligent Key (B)) is shown with the instrument panel removed. The remote keyless entry receiver receives the air pressure signal transmitted by the transmitter in each wheel.

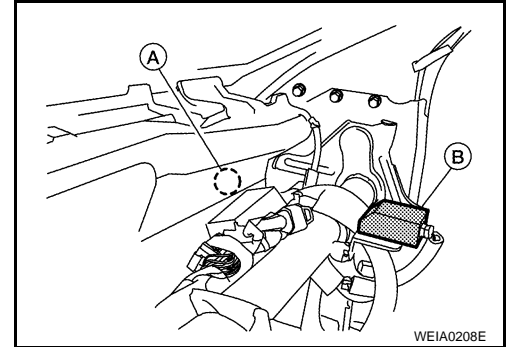

COMBINATION METER

The combination meter receives tire pressure status from the BCM using CAN communication. When a low tire pressure condition is sensed by the BCM, the combination meter low tire pressure warning lamp is activated.



TIRE PRESSURE WARNING CHECK CONNECTOR

The tire pressure warning check connector can be grounded in order to initiate self-diagnosis without a CONSULT-III. Refer to [WT-18. "Self-Diagnosis \(Without CONSULT-III\)"](#). The tire pressure warning check connector is located behind the instrument panel LH. Refer to [PG-36. "Harness Layout"](#).

CAN COMMUNICATION

< SERVICE INFORMATION >

CAN COMMUNICATION

System Description

INFOID:000000004407383

Refer to [LAN-6. "System Description"](#).

A

B

C

D

WT

F

G

H

I

J

K

L

M

N

O

P

TROUBLE DIAGNOSIS

< SERVICE INFORMATION >

TROUBLE DIAGNOSIS

Wiring Diagram- T/WARN -

INFOID:000000004407384

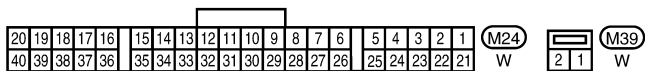
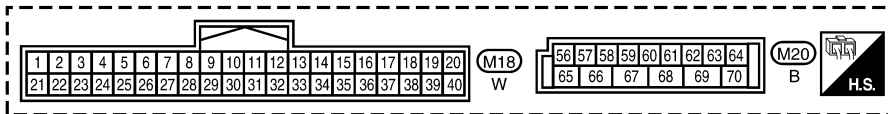
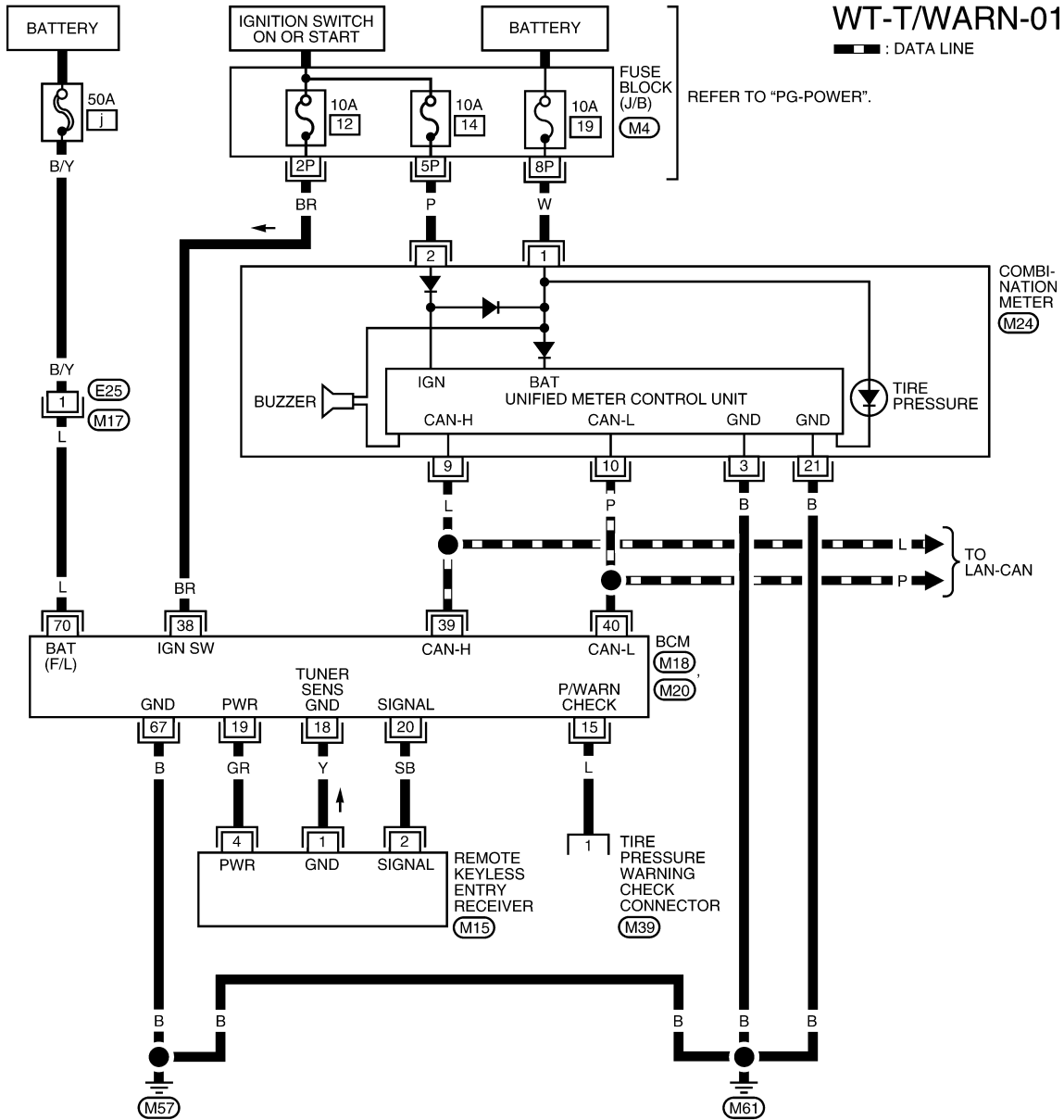

AWEWA0010GI

Terminal and Reference Value for BCM

INFOID:000000004407385

Refer to [BCS-11, "Terminal and Reference Value for BCM"](#).

TROUBLE DIAGNOSIS

< SERVICE INFORMATION >

ID Registration Procedure

INFOID:000000004407386

ID REGISTRATION WITH TRANSMITTER ACTIVATION TOOL

NOTE:

This procedure must be done after replacement of a low tire pressure warning transmitter or BCM. New replacement transmitters are provided "asleep" and must first be "woken up" using Transmitter Activation Tool J-45295 before ID registration can be performed.

1. Connect CONSULT-III.
2. Select "AIR PRESSURE MONITOR" on BCM.
3. Select "WORK SUPPORT" and select "ID REGIST".
4. Push the transmitter activation tool against the tire near the front left transmitter. Press the button for 5 seconds.

Tool number : (J-45295)

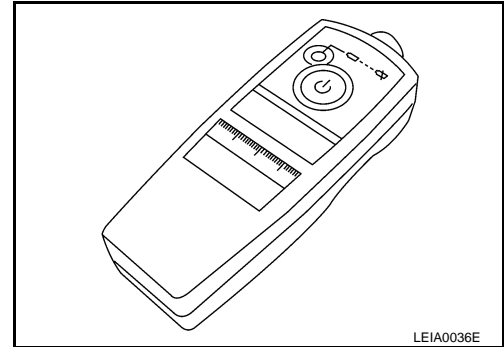

5. Register the IDs in order from FR LH, FR RH, RR RH and RR LH. When ID registration of each wheel has been completed the hazard warning lamps flash.

	Activation tire position	Hazard warning lamp	CONSULT-III
1	Front LH	2 times flashing	"YET" ↓ "DONE"
2	Front RH		
3	Rear RH		
4	Rear LH		

6. After completing all ID registrations, press "END" to complete the procedure.

NOTE:

Be sure to register the IDs in order from FR LH, FR RH, RR RH, to RR LH, or the self-diagnostic results display will not function properly.

ID REGISTRATION WITHOUT TRANSMITTER ACTIVATION TOOL

NOTE:

This procedure must be done after replacement of a low tire pressure warning transmitter or BCM. New replacement transmitters are provided "asleep" and must first be "woken up" using Transmitter Activation Tool J-45295 before ID registration can be performed.

1. Connect CONSULT-III.
2. Select "AIR PRESSURE MONITOR" on BCM.
3. Select "WORK SUPPORT" and select "ID REGIST".
4. Adjust the tire pressure to the values shown in the table below and drive the vehicle at 40 km/h (25 MPH) or more for a few minutes.

Tire position	Tire pressure kPa (kg/cm ² , psi)
Front – Left	250 (2.5, 36)
Front – Right	230 (2.3, 33)
Rear – Right	210 (2.1, 30)
Rear – Left	190 (1.9, 27)

5. After completing all ID registrations, press "END" to complete the procedure.

A
B
C
D
WT
F
G
H
I
J
K
L
M
N
O
P

TROUBLE DIAGNOSIS

< SERVICE INFORMATION >

Activation tire position	CONSULT-III
Front LH	"YET" ↓ "DONE"
Front RH	
Rear RH	
Rear LH	

6. Inflate all tires to proper pressure. Refer to [WT-27, "Tire"](#).

Transmitter Wake Up Operation

INFOID:000000004407387

NOTE:

This procedure must be done after replacement of a low tire pressure warning transmitter or BCM. New replacement transmitters are provided "asleep" and must first be "woken up" using Transmitter Activation Tool J-45295 before ID registration can be performed.

1. Turn ignition switch ON. Push the transmitter activation tool against the tire near the front left transmitter. Press the button for 5 seconds. The hazard warning lamps flash per the diagram below.

Tool number : (J-45295)

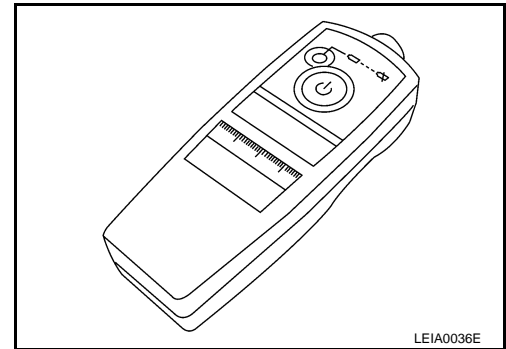

2. Repeat this procedure for each tire in the following order: FL, FR, RR, RL.
3. When the BCM finishes assigning each tire ID, the BCM flashes the hazard warning lamps and sends flashing indicator status by CAN according to the following time chart.

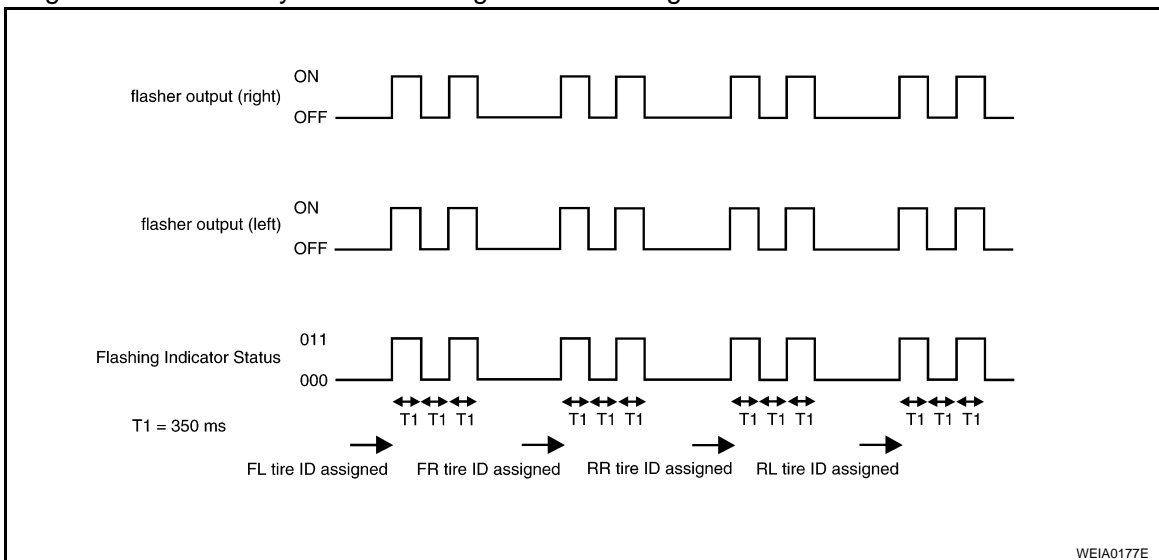

4. After completing wake up of all transmitters, make sure low tire pressure warning lamp goes out.

CONSULT-III Function (BCM)

INFOID:000000004407388

CONSULT-III can display each diagnostic item using the diagnostic test modes shown following.

TROUBLE DIAGNOSIS

< SERVICE INFORMATION >

BCM diagnostic test item	Diagnostic mode	Description
Inspection by part	WORK SUPPORT	Supports inspections and adjustments. Commands are transmitted to the BCM for setting the status suitable for required operation, input/output signals are received from the BCM and received data is displayed.
	DATA MONITOR	Displays BCM input/output data in real time.
	ACTIVE TEST	Operation of electrical loads can be checked by sending drive signal to them.
	SELF-DIAG RESULTS	Displays BCM self-diagnosis results.
	CAN DIAG SUPPORT MNTR	The result of transmit/receive diagnosis of CAN communication can be read.
	ECU PART NUMBER	BCM part number can be read.
	CONFIGURATION	Performs BCM configuration read/write functions.

How to Perform Trouble Diagnosis for Quick and Accurate Repair

INFOID:000000004407389

INTRODUCTION

- Before troubleshooting, verify customer complaints.
- If a vehicle malfunction is difficult to reproduce, harnesses, harness connectors or terminals may be malfunctioning. Hold and shake these parts to make sure they are securely connected.
- When using a circuit tester to measure voltage or resistance of each circuit, be careful not to damage or deform connector terminals.

WORK FLOW

TROUBLE DIAGNOSIS

< SERVICE INFORMATION >

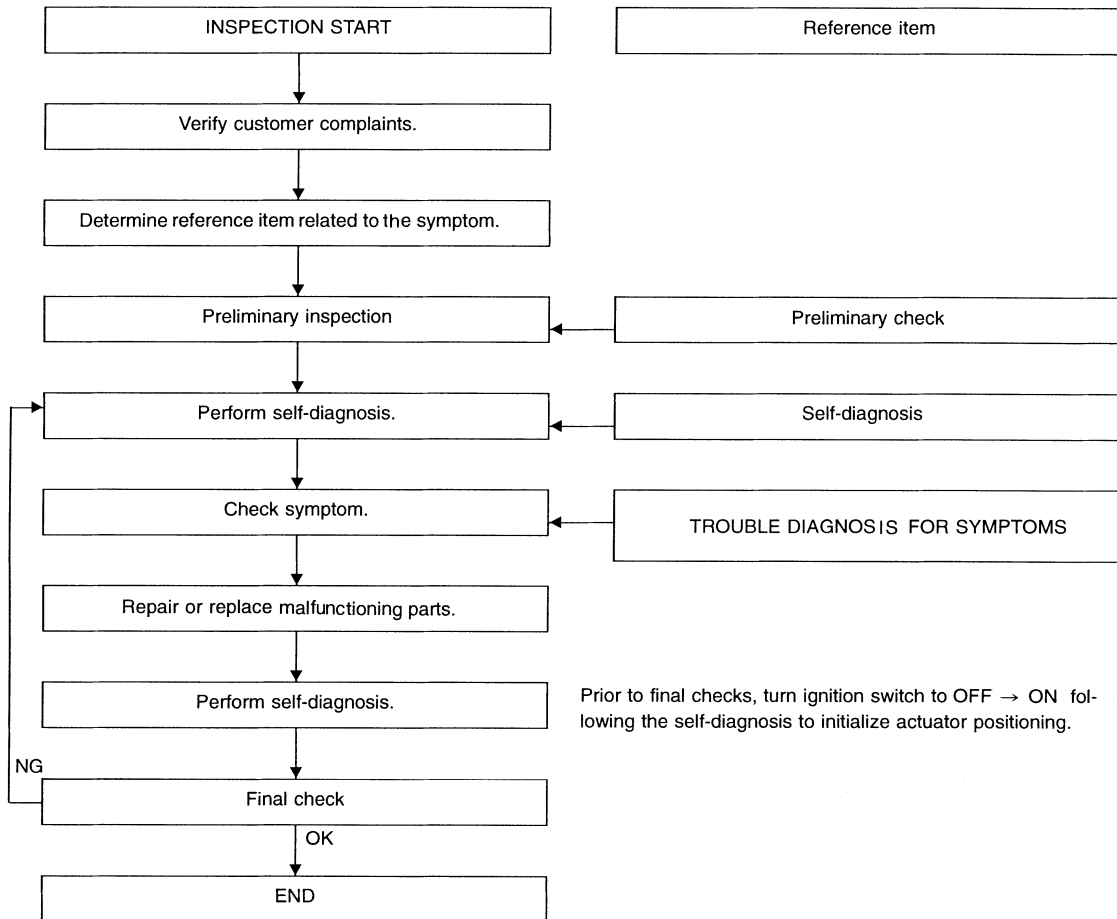

SEIA0100E

Preliminary check : [WT-16](#) Self-diagnosis : [WT-17](#) Trouble diagnosis for symptoms : [WT-23](#)

Preliminary Check

INFOID:000000004407390

BASIC INSPECTION

1.CHECK ALL TIRE PRESSURES

Check all tire pressures. Refer to [WT-27, "Tire"](#).

Do tire pressures match specifications?

YES >> GO TO 2.

NO >> Adjust tire pressure to specified value.

2.CHECK LOW TIRE PRESSURE WARNING LAMP ACTIVATION

Check low tire pressure warning lamp activation.

Does warning lamp activate for 1 second when ignition switch is turned ON?

YES >> GO TO 3.

NO >> GO TO [WT-23, "Low Tire Pressure Warning Lamp Does Not Come On When Ignition Switch Is Turned On"](#).

3.CHECK BCM CONNECTOR

1. Disconnect BCM harness connector.
2. Check terminals for damage or loose connection.

TROUBLE DIAGNOSIS

< SERVICE INFORMATION >

3. Reconnect harness connector.

Are BCM connectors damaged or loose?

- YES >> Repair or replace damaged parts.
- NO >> GO TO 4.

4. CHECK TRANSMITTER ACTIVATION TOOL

Check transmitter activation tool battery.

Is transmitter activation tool battery fully charged?

- YES >> Carry out self-diagnosis.
- NO >> Replace battery in transmitter activation tool.

Self-Diagnosis (With CONSULT-III)

INFOID:000000004407391

DESCRIPTION

During driving, the tire pressure monitoring system receives the signal transmitted from the transmitter installed in each wheel, and turns on the low tire pressure warning lamp when the tire pressure becomes low. The control unit (BCM) for this system has pressure judgement and self-diagnosis functions.

FUNCTION

When the tire pressure monitoring system detects low inflation pressure or an internal malfunction, the low tire pressure warning lamp in the combination meter comes on. The malfunction location is indicated by the low tire pressure warning lamp flashing and the buzzer sounding.

CONSULT-III Application to Tire Pressure Monitoring System

ITEM	SELF-DIAGNOSTIC RESULTS	DATA MONITOR
Front - Left transmitter	×	×
Front - Right transmitter	×	×
Rear - Left transmitter	×	×
Rear - Right transmitter	×	×
Warning lamp	—	×
Vehicle speed	×	×
Buzzer (in combination meter)	—	×
CAN Communication	×	×

× : Applicable

— : Not applicable

Self-Diagnostic Results Mode

Diagnostic item	Diagnostic item is detected when ...	Reference page
LOW - PRESSURE - FL [C1704] LOW - PRESSURE - FR [C1705] LOW - PRESSURE - RR [C1706] LOW - PRESSURE - RL [C1707]	Tire Pressure dropped below specified value. Refer to WT-9 , "System Description".	—
[NO-DATA] - FL [C1708] [NO-DATA] - FR [C1709] [NO-DATA] - RR [C1710] [NO-DATA] - RL [C1711]	Data from FL transmitter cannot be received. Data from FR transmitter cannot be received. Data from RR transmitter cannot be received. Data from RL transmitter cannot be received.	WT-20
[CHECKSUM- ERR] - FL [C1712] [CHECKSUM- ERR] - FR [C1713] [CHECKSUM- ERR] - RR [C1714] [CHECKSUM- ERR] - RL [C1715]	Checksum data from FL transmitter is malfunctioning. Checksum data from FR transmitter is malfunctioning. Checksum data from RR transmitter is malfunctioning. Checksum data from RL transmitter is malfunctioning.	WT-20
[PRESSDATA- ERR] - FL [C1716] [PRESSDATA- ERR] - FR [C1717] [PRESSDATA- ERR] - RR [C1718] [PRESSDATA- ERR] - RL [C1719]	Air pressure data from FL transmitter is malfunctioning. Air pressure data from FR transmitter is malfunctioning. Air pressure data from RR transmitter is malfunctioning. Air pressure data from RL transmitter is malfunctioning.	WT-21

TROUBLE DIAGNOSIS

< SERVICE INFORMATION >

Diagnostic item	Diagnostic item is detected when ...	Reference page
[CODE- ERR] - FL [C1720] [CODE- ERR] - FR [C1721] [CODE- ERR] - RR [C1722] [CODE- ERR] - RL [C1723]	Function code data from FL transmitter is malfunctioning. Function code data from FR transmitter is malfunctioning. Function code data from RR transmitter is malfunctioning. Function code data from RL transmitter is malfunctioning.	WT-20
[BATT - VOLT - LOW] - FL [C1724] [BATT - VOLT - LOW] - FR [C1725] [BATT - VOLT - LOW] - RR [C1726] [BATT - VOLT - LOW] - RL [C1727]	Battery voltage of FL transmitter drops. Battery voltage of FR transmitter drops. Battery voltage of RR transmitter drops. Battery voltage of RL transmitter drops.	WT-20
VHCL_SPEED_SIG_ERR [C1729]	Vehicle speed signal is in error.	WT-21
IGN_CIRCUIT_OPEN [C1735]	Vehicle ignition signal is in error.	WT-22

NOTE:

Before performing the self-diagnosis, be sure to register the ID or else the actual malfunction location may be different from that displayed on CONSULT-III.

Data Monitor Mode

MONITOR	CONDITION	SPECIFICATION
VHCL SPEED	Drive vehicle.	Vehicle speed (km/h or MPH)
AIR PRESS FL AIR PRESS FR AIR PRESS RR AIR PRESS RL	<ul style="list-style-type: none"> Drive vehicle for a few minutes. <p style="text-align: center;">or</p> <ul style="list-style-type: none"> Ignition switch ON and activation tool is transmitting activation signals. 	Tire pressure (kPa or psi)
ID REGST FL1 ID REGST FR1 ID REGST RR1 ID REGST RL1	Ignition switch ON	Registration ID: DONE No registration ID: YET
WARNING LAMP		Low tire pressure warning lamp on: ON Low tire pressure warning lamp off: OFF
BUZZER		Buzzer in combination meter on: ON Buzzer in combination meter off: OFF

NOTE:

Before performing the self-diagnosis, be sure to register the ID, or the actual malfunction location may be different from that displayed on CONSULT-III.

Self-Diagnosis (Without CONSULT-III)

INFOID:000000004407392

SELF DIAGNOSTIC PROCEDURE (WITHOUT CONSULT-III)

1. Turn ignition switch ON.
2. Ground the tire pressure warning check connector to initiate self diagnosis.
3. Compare the flashing pattern with the flash code chart below.

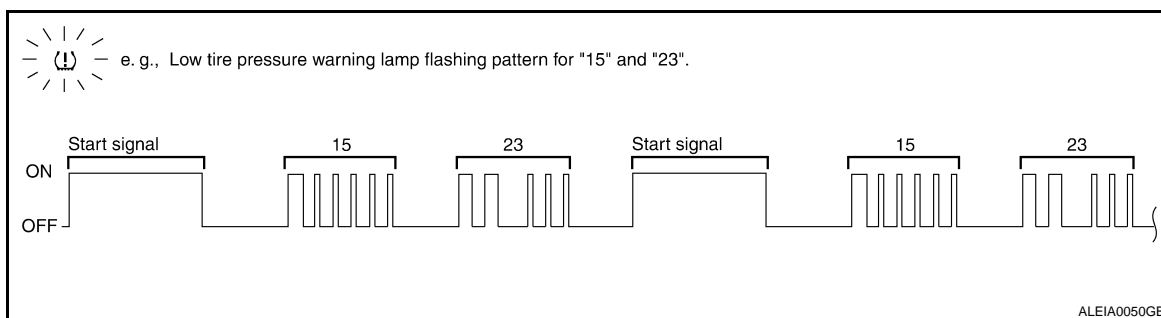

NOTE:

The system is normal when the low tire pressure warning lamp flashes 5 times and continues repeating. Self-diagnosis results are erased automatically by turning the ignition switch "OFF".

TROUBLE DIAGNOSIS

< SERVICE INFORMATION >

Flash Code or Symptom	Malfunction part	Reference page
15 16 17 18	Tire pressure dropped below specified value. Refer to WT-9, "System Description" .	—
21 22 23 24	Transmitter no data (FL) Transmitter no data (FR) Transmitter no data (RR) Transmitter no data (RL)	WT-20
31 32 33 34	Transmitter checksum error (FL) Transmitter checksum error (FR) Transmitter checksum error (RR) Transmitter checksum error (RL)	WT-20
35 36 37 38	Transmitter pressure data error (FL) Transmitter pressure data error (FR) Transmitter pressure data error (RR) Transmitter pressure data error (RL)	WT-21
41 42 43 44	Transmitter function code error (FL) Transmitter function code error (FR) Transmitter function code error (RR) Transmitter function code error (RL)	WT-20
45 46 47 48	Transmitter battery voltage low (FL) Transmitter battery voltage low (FR) Transmitter battery voltage low (RR) Transmitter battery voltage low (RL)	WT-20
52	Vehicle speed signal	WT-21
54	Vehicle ignition signal	WT-22
Low tire pressure warning lamp does not come on when ignition switch is turned on.	<ul style="list-style-type: none"> • Fuse or combination meter • BCM connector or circuit • BCM 	WT-23
Low tire pressure warning lamp stays on when ignition switch is turned on.	<ul style="list-style-type: none"> • Combination meter • BCM connector or circuit • BCM 	WT-23
Low tire pressure warning lamp flashes when ignition switch is turned on.	<ul style="list-style-type: none"> • BCM harness connector or circuit • BCM • Transmitter's mode off • ID registration not completed yet 	WT-23
Hazard warning lamps flash when ignition switch is turned on.	<ul style="list-style-type: none"> • BCM harness connector or circuit • BCM 	WT-24
ID registration cannot be completed.	<ul style="list-style-type: none"> • Transmitter • Remote keyless entry receiver harness connector or circuit • Remote keyless entry receiver • BCM harness connector or circuit • BCM 	WT-24

A
B
C
D
WT
F
G
H
I
J
K
L
M
N
O
P

TROUBLE DIAGNOSIS FOR SELF-DIAGNOSTIC ITEMS

< SERVICE INFORMATION >

TROUBLE DIAGNOSIS FOR SELF-DIAGNOSTIC ITEMS

Data from Transmitter Not Being Received

INFOID:000000004407393

MALFUNCTION CODE NO. 21, 22, 23 OR 24 (DTC C1708, C1709, C1710 OR C1711)

1. CHECK BCM

Drive for several minutes. Check all tire pressures with CONSULT-III.

Are all tire pressures displayed as 0 kPa?

- YES >> GO TO 2.
- NO >> GO TO 3.

2. CHECK REMOTE KEYLESS ENTRY RECEIVER CONNECTOR

Check remote keyless entry receiver connector for damage or loose connections.

Is the remote keyless entry receiver connector damaged or loose?

- YES >> Repair or replace remote keyless entry receiver connector.
- NO >> Replace BCM, then GO TO 3. Refer to [BCS-17, "Removal and Installation of BCM"](#).

3. PERFORM ID REGISTRATION

Carry out ID registration of all transmitters. Refer to [WT-13, "ID Registration Procedure"](#).

Is there a tire that cannot register ID?

- YES >> Replace transmitter of the tire, then GO TO 5. Refer to [WT-25, "Transmitter \(Pressure Sensor\)"](#).
- NO >> GO TO 4.

4. DRIVE VEHICLE

1. Drive at a speed of 40 km/h (25 MPH) or more for several minutes without stopping.
2. Check all tire pressures with CONSULT-III within 15 minutes after vehicle speed becomes 17 km/h (11 MPH).

Does "DATA MONITOR ITEM" display tire pressure as normal without any warning lamp?

- YES >> Inspection End.
- NO >> GO TO 5.

5. ID REGISTRATION AND VEHICLE DRIVING

1. Carry out ID registration of all transmitters. Refer to [WT-13, "ID Registration Procedure"](#).
2. Drive at a speed of 40 km/h (25 MPH) or more for 3 minutes, and then drive the vehicle at any speed for 10 minutes.
3. Check all tire pressures with CONSULT-III within 5 minutes.

Does "DATA MONITOR ITEM" display tire pressure as normal without any warning lamp?

- YES >> Inspection End.
- NO >> GO TO the inspection applicable to DTC.

Transmitter Malfunction

INFOID:000000004407394

MALFUNCTION CODE NO. 31, 32, 33, 34, 41, 42, 43, 44, 45, 46, 47 OR 48 (DTC C1712, C1713, C1714, C1715, C1720, C1721, C1722, C1723, C1724, C1725, C1726 OR C1727)

1. PERFORM ID REGISTRATION

1. Carry out ID registration of all transmitters. Refer to [WT-13, "ID Registration Procedure"](#).
2. Drive at a speed of 40 km/h (25 MPH) or more for 3 minutes, and then drive the vehicle at any speed for 10 minutes.

>> GO TO 2.

2. REPLACE TRANSMITTER

1. Check low tire pressure warning lamp again for flashing, replace malfunctioning transmitter. Refer to [WT-25, "Transmitter \(Pressure Sensor\)"](#).
2. Carry out ID registration of all transmitters. Refer to [WT-13, "ID Registration Procedure"](#).

TROUBLE DIAGNOSIS FOR SELF-DIAGNOSTIC ITEMS

< SERVICE INFORMATION >

Can ID registration of all transmitters be completed?

YES >> GO TO 3.

NO >> GO TO [WT-20. "Data from Transmitter Not Being Received"](#).

3.DRIVE VEHICLE

1. Drive at a speed of 40 km/h (25 MPH) or more for 3 minutes, and then drive the vehicle at any speed for 10 minutes.
2. Check all tire pressures with CONSULT-III within 5 minutes.

Does "DATA MONITOR ITEM" display tire pressure as normal without any warning lamp?

YES >> Inspection End.

NO >> Replace malfunctioning transmitter, and perform Step 3 again. Refer to [WT-25. "Transmitter \(Pressure Sensor\)"](#).

Transmitter Pressure Malfunction

INFOID:000000004407395

MALFUNCTION CODE NO. 35, 36, 37 OR 38 (DTC C1716, C1717, C1718 OR C1719)

1.CHECK ALL TIRE PRESSURES

Check all tire pressures. Refer to [WT-27. "Tire"](#).

Are there any tires with pressure of 64 psi or more?

YES >> Adjust tire pressure to specified value.

NO >> GO TO 2.

2.ID REGISTRATION AND VEHICLE DRIVING

1. Carry out ID registration of all transmitters. Refer to [WT-13. "ID Registration Procedure"](#).
2. Drive at a speed of 40 km/h (25 MPH) or more for several minutes without stopping.
3. Check all tire pressures with CONSULT-III within 15 minutes after vehicle speed becomes 17 km/h (11 MPH).

Does "DATA MONITOR ITEM" display 64 psi or more?

YES >> Replace transmitter. Refer to [WT-25. "Transmitter \(Pressure Sensor\)"](#). GO TO 3.

NO >> GO TO 3.

3.ID REGISTRATION AND VEHICLE DRIVING

1. Carry out ID registration of all transmitters. Refer to [WT-13. "ID Registration Procedure"](#).
2. Drive at a speed of 40 km/h (25 MPH) or more for 3 minutes, and then drive the vehicle at any speed for 10 minutes.
3. Check all tire pressures with CONSULT-III within 5 minutes.

Does "DATA MONITOR ITEM" display tire pressure as normal without any warning lamp?

YES >> Inspection End.

NO >> GO TO the inspection applicable to DTC.

Vehicle Speed Signal

INFOID:000000004407396

MALFUNCTION CODE NO. 52 (DTC C1729)

1.SELF-DIAGNOSTIC RESULT CHECK

Using CONSULT-III, check display contents in self-diagnostic results.

Is "CAN COMM CIRCUIT" displayed in the self-diagnosis display items?

YES >> Malfunction in CAN communication system. GO TO [LAN-15. "Trouble Diagnosis Flow Chart"](#).

NO >> GO TO 2.

2.CHECK BCM

Perform BCM diagnosis. Refer to [BCS-15. "CONSULT-III Function \(BCM\)"](#).

Inspection results OK?

YES >> Perform Vehicle Speed Sensor Inspection. Refer to [CVT-78. "Diagnosis Procedure"](#).

NO >> Replace BCM. Refer to [BCS-17. "Removal and Installation of BCM"](#).

TROUBLE DIAGNOSIS FOR SELF-DIAGNOSTIC ITEMS

< SERVICE INFORMATION >

Vehicle Ignition Signal

INFOID:000000004407397

MALFUNCTION CODE NO. 54 (DTC C1735)

1. CAN IGNITION SIGNAL

Check BCM IGN RLY signal with CONSULT-III. Refer to [BCS-11, "Terminal and Reference Value for BCM"](#).

Are the inspection results normal with the ignition switch ON?

YES >> GO TO 2.

NO >> Check CAN system. Refer to [LAN-15, "Trouble Diagnosis Flow Chart"](#).

2. BCM POWER SUPPLY

Check BCM power supply (ignition ON). Refer to [BCS-14, "BCM Power Supply and Ground Circuit Inspection"](#).

Is the power supply with the ignition switch ON normal?

YES >> GO TO 3.

NO >> Repair power supply as necessary.

3. DRIVE VEHICLE

Clear DTC and then test drive the vehicle and check the low tire pressure warning lamp.

Does the vehicle operate without any low tire pressure warning lamp?

YES >> Inspection End.

NO >> Replace BCM. Refer to [BCS-17, "Removal and Installation of BCM"](#).

TROUBLE DIAGNOSIS FOR SYMPTOMS

< SERVICE INFORMATION >

TROUBLE DIAGNOSIS FOR SYMPTOMS

Low Tire Pressure Warning Lamp Does Not Come On When Ignition Switch Is Turned On

INFOID:000000004407398

DIAGNOSTIC PROCEDURE

1.SELF-DIAGNOSTIC RESULT CHECK

Using CONSULT-III, check display contents in self-diagnostic results.

Is "CAN COMM CIRCUIT" displayed in the self-diagnosis display items?

- YES >> Malfunction in CAN communication system. GO TO [LAN-15, "Trouble Diagnosis Flow Chart"](#).
NO >> GO TO 2.

2.CHECK COMBINATION METER

Check combination meter operation. Refer to [DI-13, "Self-Diagnosis Mode of Combination Meter"](#).

Inspection results OK?

- YES >> GO TO 3.
NO >> Replace combination meter. Refer to [IP-12, "Removal and Installation"](#).

3.CHECK LOW TIRE PRESSURE WARNING LAMP

Disconnect BCM harness connector.

Does the low tire pressure warning lamp activate?

- YES >> Replace BCM. Refer to [BCS-17, "Removal and Installation of BCM"](#).
NO >> Check combination meter operation. Refer to [DI-13, "Self-Diagnosis Mode of Combination Meter"](#).

Low Tire Pressure Warning Lamp Stays On When Ignition Switch Is Turned On

INFOID:000000004407399

DIAGNOSTIC PROCEDURE

1.CHECK BCM CONNECTORS

1. Turn ignition switch OFF.
2. Disconnect BCM harness connectors M18 and M20.
3. Check terminals for damage or loose connections.

Are any of the BCM connectors loose or damaged?

- YES >> Repair or replace damaged parts.
NO >> GO TO 2.

2.CHECK BCM POWER SUPPLY AND GROUND CIRCUITS

Refer to [BCS-14, "BCM Power Supply and Ground Circuit Inspection"](#).

Are the BCM power supply and ground circuits OK?

- YES >> Replace BCM. Refer to [BCS-17, "Removal and Installation of BCM"](#).
NO >> Repair BCM power supply or ground circuits.

Low Tire Pressure Warning Lamp Flashes When Ignition Switch Is Turned On

INFOID:000000004407400

NOTE:

If low tire pressure warning lamp flashes as shown, the system is normal.
Flash Mode A

TROUBLE DIAGNOSIS FOR SYMPTOMS

< SERVICE INFORMATION >

- This mode shows transmitter status is OFF-mode.
Carry out transmitter wake up operation. Refer to [WT-14, "Transmitter Wake Up Operation"](#).

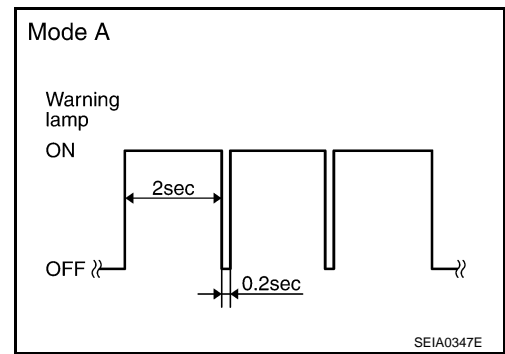

DIAGNOSTIC PROCEDURE

1. CHECK BCM CONNECTORS

- Turn ignition switch OFF.
- Disconnect BCM harness connectors M18 and M20.
- Check terminals for damage or loose connections.

Inspection results OK?

- YES >> GO TO 2.
NO >> Repair or replace damaged parts.

2. CHECK TIRE PRESSURE WARNING CHECK CONNECTOR CIRCUIT

Check continuity between BCM harness connector M18 terminal 15 and ground.

Continuity should not exist.

Does continuity exist?

- YES >> Repair circuit for short to ground.
NO >> Replace BCM. Refer to [BCS-17, "Removal and Installation of BCM"](#).

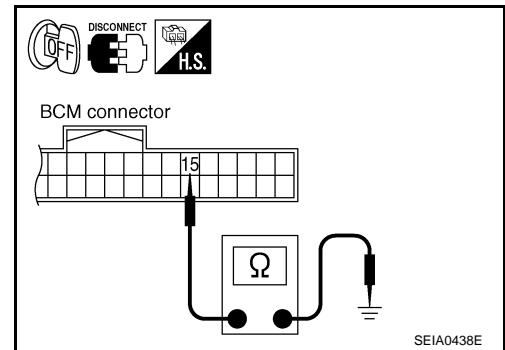

Hazard Warning Lamps Flash When Ignition Switch Is Turned On

INFOID:000000004407401

DIAGNOSTIC PROCEDURE

1. CHECK BCM GROUND CIRCUIT

Check BCM ground circuit. Refer to [BCS-14, "BCM Power Supply and Ground Circuit Inspection"](#).

Is BCM ground circuit OK?

- YES >> Replace BCM. Refer to [BCS-17, "Removal and Installation of BCM"](#).
NO >> Repair BCM ground circuit.

ID Registration Cannot Be Completed

INFOID:000000004407402

DIAGNOSTIC PROCEDURE

1. PERFORM ID REGISTRATION OF ALL TRANSMITTERS

Carry out ID registration of all transmitters. Refer to [WT-13, "ID Registration Procedure"](#).

Can ID registration of all transmitters be completed?

- YES >> Inspection End.
NO >> GO TO [WT-20, "Data from Transmitter Not Being Received"](#).

REMOVAL AND INSTALLATION

< SERVICE INFORMATION >

REMOVAL AND INSTALLATION

Transmitter (Pressure Sensor)

INFOID:000000004407403

REMOVAL

1. Remove wheel and tire using power tool.
2. Deflate tire. Unscrew transmitter retaining nut and allow transmitter to fall into tire.
3. Gently bounce tire so that transmitter falls to bottom of tire. Place wheel and tire assembly on tire changing machine and break both tire beads. Ensure that the transmitter remains at the bottom of the tire while breaking the bead.

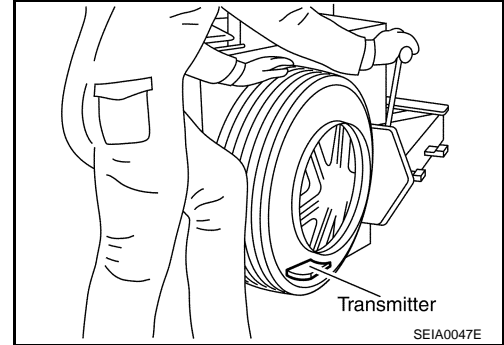

4. Turn tire so that valve hole is at bottom, and gently bounce the tire to ensure transmitter is near valve hole. Carefully lift tire onto turntable and position valve hole (and transmitter) 270 degrees from mounting/dismounting head.
5. Lubricate tire well, and remove top side of tire. Reach inside the tire and remove the transmitter.
6. Remove the second side of the tire as normal.

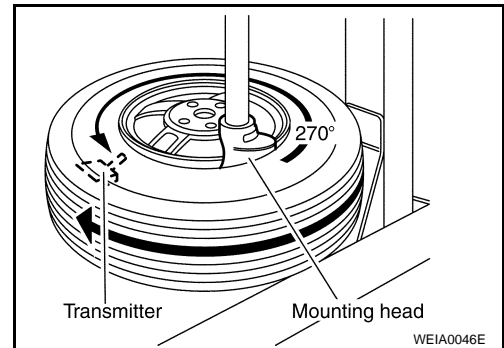

INSTALLATION

1. Place first side of tire onto rim.

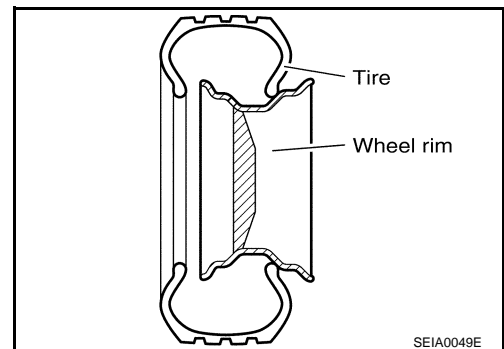

2. Apply suitable silicone lubricant to new transmitter seal then install seal on transmitter. Refer to [MA-14](#).
NOTE:
Always replace the seal after every disassembly.
3. Mount transmitter on rim and tighten nut.
NOTE:
Make sure no burrs exist in the valve stem hole of the wheel.

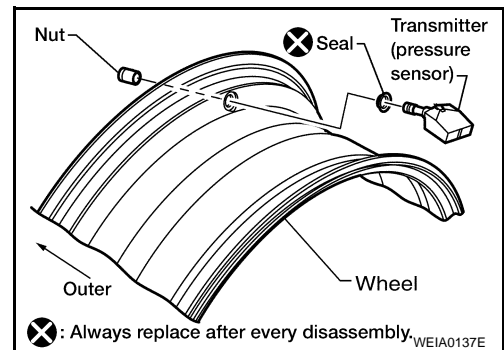

Transmitter nut : 7.7 N·m (0.79 kg·m, 68 in·lb)

A
B
C
D
WT
F
G
H
I
J
K
L
M
N
O
P

REMOVAL AND INSTALLATION

< SERVICE INFORMATION >

4. Place wheel on turntable of tire machine. Ensure that transmitter is 270 degrees from mounting/dismounting head.

NOTE:

Do not touch transmitter with mounting head.

5. Lubricate tire well, and install second side of tire as normal. Ensure that tire does not rotate relative to rim.
6. Inflate tire and balance the wheel and tire assembly. Refer to [WT-6, "Balancing Wheels"](#).
7. Install wheel and tire assembly in appropriate wheel position on vehicle. Refer to [WT-8, "Rotation"](#).

NOTE:

If replacing the transmitter, then transmitter wake up operation must be performed. Refer to [WT-14, "Transmitter Wake Up Operation"](#).

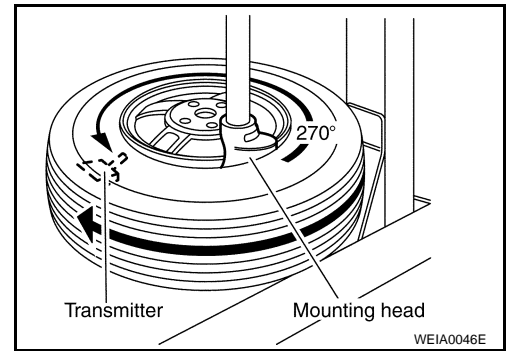

SERVICE DATA AND SPECIFICATIONS (SDS)

< SERVICE INFORMATION >

SERVICE DATA AND SPECIFICATIONS (SDS)

Road Wheel

INFOID:000000004407404

Standard item		Allowable	
		Aluminum	Steel
Maximum radial runout limit	Lateral deflection	Less than 0.3 mm (0.012 in)	Less than 0.5 mm (0.020 in)
	Radial deflection	Less than 0.3 mm (0.012 in)	Less than 0.8 mm (0.031 in)
Maximum allowable unbalance	Dynamic (At rim flange)	Less than 5 g (0.18 oz) (one side)	
	Static (At rim flange)	Less than 10 g (0.35 oz)	

Tire

INFOID:000000004407405

Unit: kPa (kg/cm², psi)

Tire size/speed rating	Cold tire inflation pressure		
	Conventional tire		Spare tire
	Front wheel	Rear wheel	
P205/60HR15	230 (2.3, 33)	230 (2.3, 33)	—
P205/55HR16	230 (2.3, 33)	230 (2.3, 33)	—
P225/45VR17	240 (2.45, 35)	240 (2.45, 35)	—
P225/45WR17	240 (2.45, 35)	240 (2.45, 35)	—
T125/70D16	—	—	420 (4.2, 60)
T135/70D17	—	—	420 (4.2, 60)