

SECTION **RSU**  
 REAR SUSPENSION

A  
 B  
 C  
 D

RSU

CONTENTS

<b>SERVICE INFORMATION</b> .....	2	On-Vehicle Inspection and Service .....	5	F
<b>PRECAUTIONS</b> .....	2	Wheel Alignment Inspection .....	5	
Precaution for Supplemental Restraint System (SRS) "AIR BAG" and "SEAT BELT PRE-TENSIONER" .....	2	Component .....	7	G
Precaution Necessary for Steering Wheel Rotation After Battery Disconnect .....	2	<b>SHOCK ABSORBER</b> .....	8	
<b>PREPARATION</b> .....	3	Removal and Installation .....	8	
Commercial Service Tool .....	3	<b>COIL SPRING</b> .....	9	H
<b>NOISE, VIBRATION AND HARSHNESS (NVH) TROUBLESHOOTING</b> .....	4	Removal and Installation .....	9	
NVH Troubleshooting Chart .....	4	<b>REAR SUSPENSION BEAM</b> .....	11	I
<b>REAR SUSPENSION ASSEMBLY</b> .....	5	Removal and Installation .....	11	
		<b>SERVICE DATA AND SPECIFICATIONS (SDS)</b> .....	12	J
		Wheel Alignment (Unladen*) .....	12	
		Wheelarch Height (Unladen*) .....	12	K

L  
 M  
 N  
 O  
 P

# PRECAUTIONS

< SERVICE INFORMATION >

## SERVICE INFORMATION

### PRECAUTIONS

#### Precaution for Supplemental Restraint System (SRS) "AIR BAG" and "SEAT BELT PRE-TENSIONER"

INFOID:000000004783753

The Supplemental Restraint System such as "AIR BAG" and "SEAT BELT PRE-TENSIONER", used along with a front seat belt, helps to reduce the risk or severity of injury to the driver and front passenger for certain types of collision. This system includes seat belt switch inputs and dual stage front air bag modules. The SRS system uses the seat belt switches to determine the front air bag deployment, and may only deploy one front air bag, depending on the severity of a collision and whether the front occupants are belted or unbelted. Information necessary to service the system safely is included in the SRS and SB section of this Service Manual.

#### **WARNING:**

- To avoid rendering the SRS inoperative, which could increase the risk of personal injury or death in the event of a collision which would result in air bag inflation, all maintenance must be performed by an authorized NISSAN/INFINITI dealer.
- Improper maintenance, including incorrect removal and installation of the SRS can lead to personal injury caused by unintentional activation of the system. For removal of Spiral Cable and Air Bag Module, see the SRS section.
- Do not use electrical test equipment on any circuit related to the SRS unless instructed to in this Service Manual. SRS wiring harnesses can be identified by yellow and/or orange harnesses or harness connectors.
- When working near the Airbag Diagnosis Sensor Unit or other Airbag System sensors with the Ignition ON or engine running, DO NOT use air or electric power tools or strike near the sensor(s) with a hammer. Heavy vibration could activate the sensor(s) and deploy the air bag(s), possibly causing serious injury.
- When using air or electric power tools or hammers, always switch the Ignition OFF, disconnect the battery, and wait at least 3 minutes before performing any service.

#### Precaution Necessary for Steering Wheel Rotation After Battery Disconnect

INFOID:000000004755158

#### **NOTE:**

- This Procedure is applied only to models with Intelligent Key system and NATS (NISSAN ANTI-THEFT SYSTEM).
- Remove and install all control units after disconnecting both battery cables with the ignition knob in the "LOCK" position.
- Always use CONSULT-III to perform self-diagnosis as a part of each function inspection after finishing work. If DTC is detected, perform trouble diagnosis according to self-diagnostic results.

For models equipped with the Intelligent Key system and NATS, an electrically controlled steering lock mechanism is adopted on the key cylinder.

For this reason, if the battery is disconnected or if the battery is discharged, the steering wheel will lock and steering wheel rotation will become impossible.

If steering wheel rotation is required when battery power is interrupted, follow the procedure below before starting the repair operation.

#### OPERATION PROCEDURE

1. Connect both battery cables.

#### **NOTE:**

Supply power using jumper cables if battery is discharged.

2. Use the Intelligent Key or mechanical key to turn the ignition switch to the "ACC" position. At this time, the steering lock will be released.
3. Disconnect both battery cables. The steering lock will remain released and the steering wheel can be rotated.
4. Perform the necessary repair operation.
5. When the repair work is completed, return the ignition switch to the "LOCK" position before connecting the battery cables. (At this time, the steering lock mechanism will engage.)
6. Perform a self-diagnosis check of all control units using CONSULT-III.

# PREPARATION

< SERVICE INFORMATION >

## PREPARATION

### Commercial Service Tool

INFOID:000000004407364

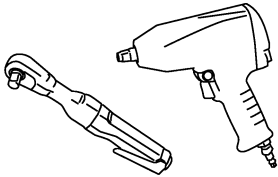
Tool name	Description
<p data-bbox="159 352 266 380">Power tool</p>  <p data-bbox="906 569 976 590">PBIC0190E</p>	<p data-bbox="1057 352 1273 380">Removing wheel nuts</p>

A

B

C

D

**RSU**

F

G

H

I

J

K

L

M

N

O

P

# NOISE, VIBRATION AND HARSHNESS (NVH) TROUBLESHOOTING

< SERVICE INFORMATION >

## NOISE, VIBRATION AND HARSHNESS (NVH) TROUBLESHOOTING

### NVH Troubleshooting Chart

INFOID:000000004407365

Use chart below to help you find the cause of the symptom. If necessary, repair or replace these parts.

Reference page		<a href="#">RSU-7</a>	<a href="#">RSU-8</a>	<a href="#">RSU-8</a>	<a href="#">RSU-8</a>	<a href="#">RSU-9</a>	<a href="#">RSU-7</a>	<a href="#">RSU-5</a>	<a href="#">RAX-5</a>	<a href="#">WT-4</a>	<a href="#">WT-4</a>	<a href="#">BR-4</a>	<a href="#">PS-6</a>
Possible cause and SUSPECTED PARTS		Improper installation, looseness	Shock absorber deformation, damage or deflection	Bushing or mounting deterioration	Parts interference	Spring fatigue	Suspension looseness	Incorrect wheel alignment	REAR AXLE	TIRES	ROAD WHEEL	BRAKES	STEERING
Symptom	Noise	x	x	x	x	x	x		x	x	x	x	x
	Shake	x	x	x	x		x		x	x	x	x	x
	Vibration	x	x	x	x	x			x	x			x
	Shimmy	x	x	x	x			x	x	x	x	x	x
	Shudder	x	x	x					x	x	x	x	x
	Poor quality ride or handling	x	x	x	x	x		x	x	x	x		

x: Applicable

# REAR SUSPENSION ASSEMBLY

< SERVICE INFORMATION >

## REAR SUSPENSION ASSEMBLY

### On-Vehicle Inspection and Service

INFOID:000000004407366

Make sure the mounting conditions (looseness, backlash) of each component and component conditions (wear, damage) are within specifications.

### SHOCK ABSORBER INSPECTION

Check shock absorber for oil leakage, damage and replace it if necessary.

### Wheel Alignment Inspection

INFOID:000000004407367

### DESCRIPTION

Measure wheel alignment under unladen conditions.

#### NOTE:

"Unladen conditions" means that fuel, engine coolant, and lubricant are full. Spare tire, jack, hand tools and mats are in designated positions.

### PRELIMINARY

Check the following:

1. Tires for improper air pressure and wear.
2. Road wheels for runout. Refer to [WT-5](#).
3. Wheel bearing axial end play. Refer to [RAX-6, "On-Vehicle Inspection and Service"](#).
4. Shock absorber operation.
5. Each mounting part of suspension for looseness and deformation.
6. Rear suspension beam for cracks, deformation, and other damage.
7. Vehicle height (posture).

### GENERAL INFORMATION AND RECOMMENDATIONS

1. A Four-Wheel Thrust Alignment should be performed.
  - This type of alignment is recommended for any NISSAN vehicle.
  - The four-wheel "thrust" process helps ensure that the vehicle is properly aligned and the steering wheel is centered.
  - The alignment machine itself should be capable of accepting any NISSAN vehicle.
  - The alignment machine should be checked to ensure that it is level.
2. Make sure the alignment machine is properly calibrated.
  - Your alignment machine should be regularly calibrated in order to give correct information.
  - Check with the manufacturer of your specific alignment machine for their recommended Service/Calibration Schedule.

### THE ALIGNMENT PROCESS

**IMPORTANT:** Use only the alignment specifications listed in this Service Manual. Refer to [RSU-12, "Wheel Alignment \(Unladen\\*\)"](#).

1. When displaying the alignment settings, many alignment machines use "indicators": (Green/red, plus or minus, Go/No Go). **Do NOT use these indicators.**
  - The alignment specifications programmed into your alignment machine that operate these indicators may not be correct.
  - This may result in an ERROR.
2. Some newer alignment machines are equipped with an optional "Rolling Compensation" method to "compensate" the sensors (alignment targets or head units). **Do NOT use this "Rolling Compensation" method.**
  - Use the "Jacking Compensation" method. After installing the alignment targets or head units, raise the vehicle and rotate the wheels 1/2 turn both ways.
  - See Instructions in the alignment machine you are using for more information.

### CAMBER INSPECTION

A  
B  
C  
D

RSU

F  
G  
H  
I

J  
K  
L

M  
N  
O  
P

# REAR SUSPENSION ASSEMBLY

## < SERVICE INFORMATION >

- Measure camber of both right and left wheels with a suitable alignment gauge.

**Camber** : Refer to [RSU-12, "Wheel Alignment \(Unladen\\*\)"](#).

- If it is out of the specification value, inspect and replace any damaged or worn rear suspension parts.

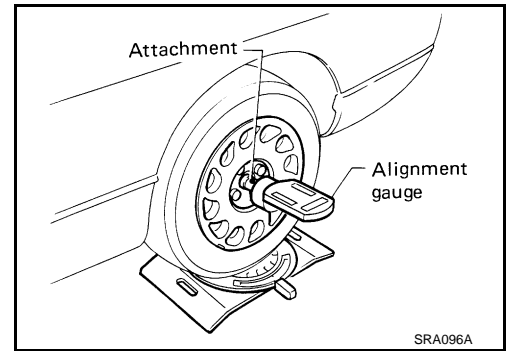

## TOE-IN INSPECTION

Measure toe-in using following procedure. If it is out of the specification, inspect and replace any damaged or worn rear suspension parts.

### **WARNING:**

- Always perform the following procedure on a flat surface.
- Make sure that no person is in front of vehicle before pushing it.

1. Bounce the rear of vehicle up and down to stabilize the vehicle height (posture).
2. Push vehicle straight ahead about 5 m (16 ft).
3. Put a mark on base line of the tread (rear side) of both tires at the same height of hub center. These are measuring points.

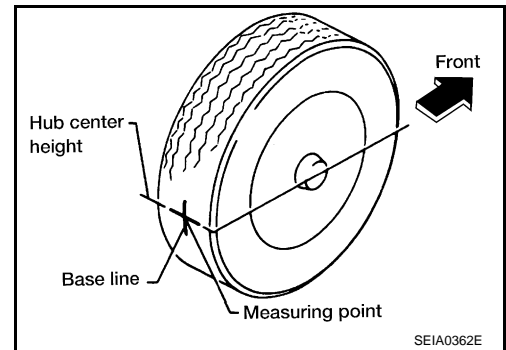

4. Measure distance (A) from rear side.
5. Push vehicle slowly ahead to rotate wheels 180 degrees (1/2 turn).

### **CAUTION:**

If wheels have rotated more than 180 degrees (1/2 turn), try the above procedure again from the beginning. Never push vehicle backward.

6. Measure distance (B) from front side.

**Total toe-in** : Refer to [RSU-12, "Wheel Alignment \(Unladen\\*\)"](#) .

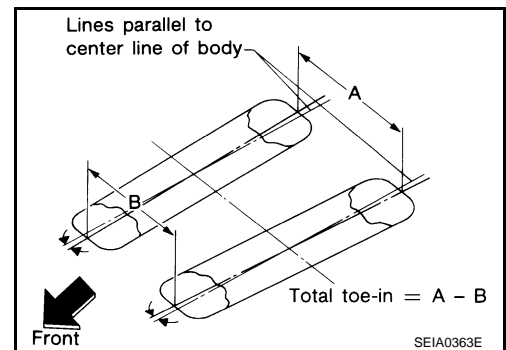

# REAR SUSPENSION ASSEMBLY

< SERVICE INFORMATION >

Component

INFOID:000000004407368

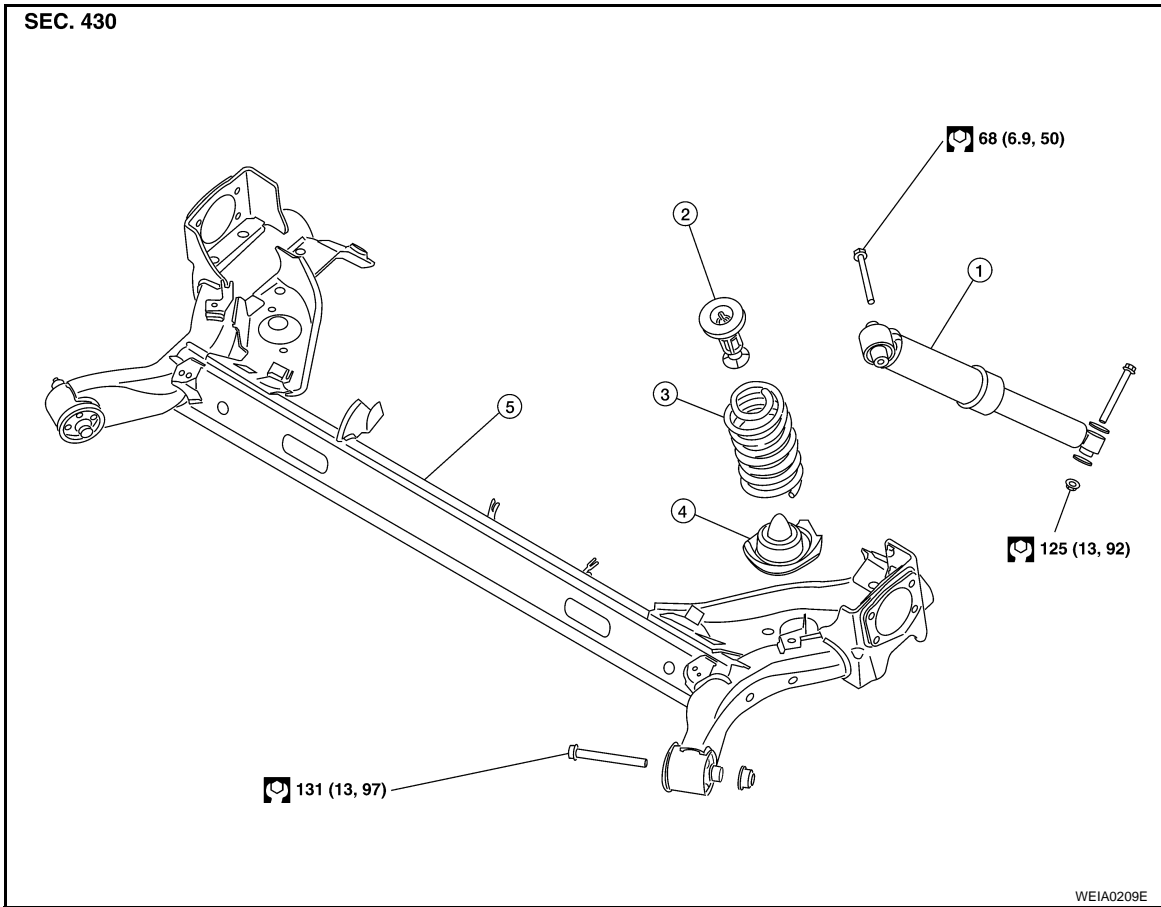

- 1. Shock absorber
- 2. Bound bumper
- 3. Coil spring
- 4. Rear spring lower rubber seat
- 5. Rear suspension beam

A

B

C

D

RSU

F

G

H

I

J

K

L

M

N

O

P

# SHOCK ABSORBER

< SERVICE INFORMATION >

## SHOCK ABSORBER

### Removal and Installation

INFOID:000000004407369

#### REMOVAL

1. Set jack under rear suspension beam.
2. Remove upper shock absorber bolt (A).

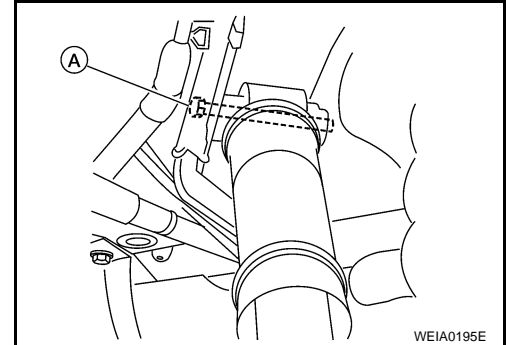

3. Remove shock absorber lower bolt (A).
4. Remove the shock absorber from vehicle.

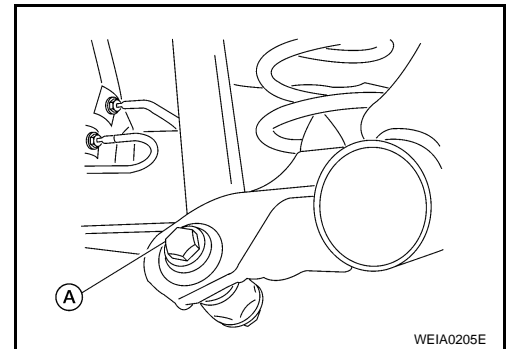

#### INSPECTION AFTER REMOVAL

Shock Absorber

Check the following:

- Shock absorber for deformation, cracks or damage, and replace if necessary.
- Piston rod for damage, uneven wear or distortion, and replace if necessary.

#### INSTALLATION

Installation is in the reverse order of removal. For tightening specifications, refer to [RSU-7, "Component"](#).



# COIL SPRING

< SERVICE INFORMATION >

## COIL SPRING

### Removal and Installation

INFOID:000000004407370

#### REMOVAL

1. Set jack under rear suspension beam.
2. Remove both shock absorber lower bolts (A).
3. Gradually lower the jack, and then remove coil spring, bound bumper and rear spring rubber seat.

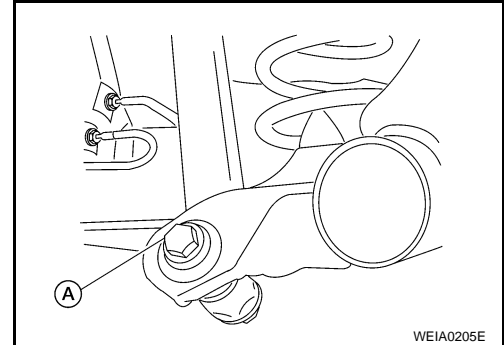

WEIA0205E

#### INSPECTION AFTER REMOVAL

Check coil spring and spring rubber seat for deformation, cracks, and damage, and replace it if a malfunction is detected.

#### INSTALLATION

Installation is in the reverse order of removal. For tightening specifications, refer to [RSU-7. "Component"](#).

- When installing rear spring rubber seat, be sure that the flat areas (A) are aligned.

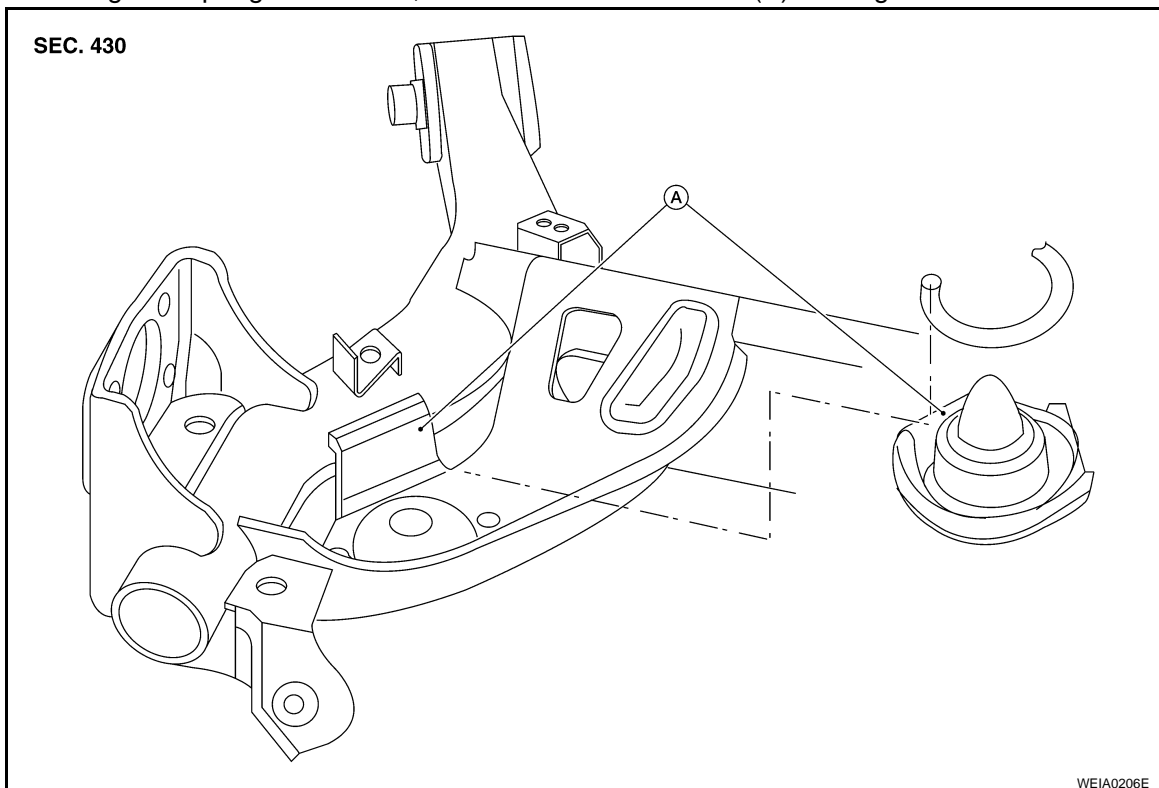

WEIA0206E

A  
B  
C  
D  
RSU  
F  
G  
H  
I  
J  
K  
L  
M  
N  
O  
P

## COIL SPRING

### < SERVICE INFORMATION >

- When installing rear spring, be sure that the gap (A) is less than 5mm.

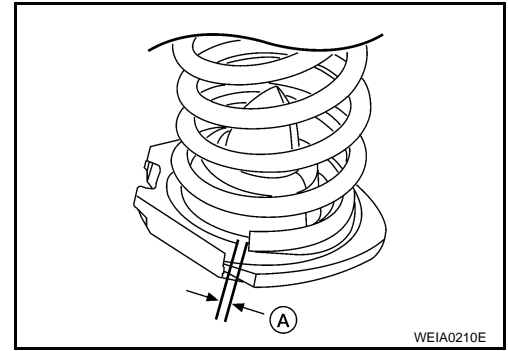

# REAR SUSPENSION BEAM

< SERVICE INFORMATION >

## REAR SUSPENSION BEAM

### Removal and Installation

INFOID:000000004407371

#### REMOVAL

1. Remove rear tires from vehicle using power tool.
2. Remove rear drum and brake assembly. Refer to [BR-41, "Removal and Installation of Drum Brake Assembly"](#).
3. Disconnect and remove parking brake rear cable. Refer to [PB-4](#).
4. Remove wheel sensor and wheel sensor harness from wheel hub and bearing assembly and rear suspension beam, if equipped. Refer to [BRC-31](#).
5. Remove rear brake tube and brake hose. Refer to [BR-13, "Rear Brake Tube and Hose"](#).
6. Remove wheel hub and bearing assembly and back plate. Refer to [RAX-6](#).
7. Set jack under rear suspension beam.
8. Remove both shock absorber lower bolts (A). Refer to [RSU-8, "Removal and Installation"](#).

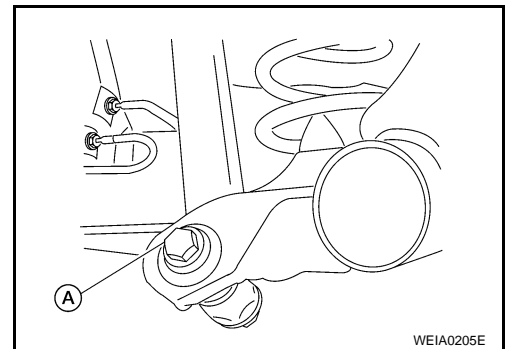

9. Remove coil springs (left/right). Refer to [RSU-9, "Removal and Installation"](#).
10. Remove brake line retaining clip and disconnect the brake line from the rear suspension beam bracket.
11. Remove center exhaust pipe assembly and insulator. Refer to [EX-4, "Removal and Installation"](#) (MR20DE), [EX-9, "Removal and Installation"](#) (QR25DE).
12. Remove rear suspension beam bolt and nut. Refer to [RSU-7, "Component"](#).
13. Gradually lower the jack to remove rear suspension beam from vehicle.

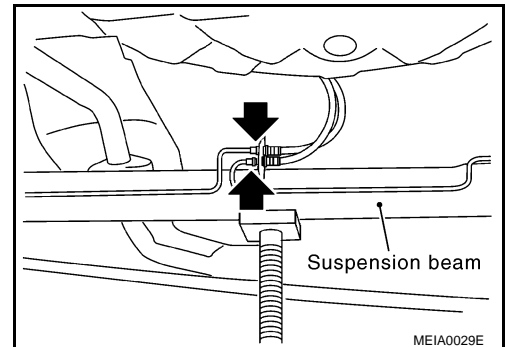

#### INSPECTION AFTER REMOVAL

Check components for deformation, cracks, and other damage, and replace if necessary.

#### INSTALLATION

Installation is in the reverse order of removal. For tightening torque, refer to [RSU-7, "Component"](#).

- Perform final tightening of rear suspension beam (A) under unladen conditions with tires on level ground.
- Refill with new brake fluid and bleed air. Refer to [BR-9, "Bleeding Brake System"](#).
- Check the following after finishing work.
  - Parking brake operation (stroke): Refer to [PB-4, "On-Vehicle Service"](#).
  - Wheel sensor harness for proper connection: Refer to [BRC-31](#)

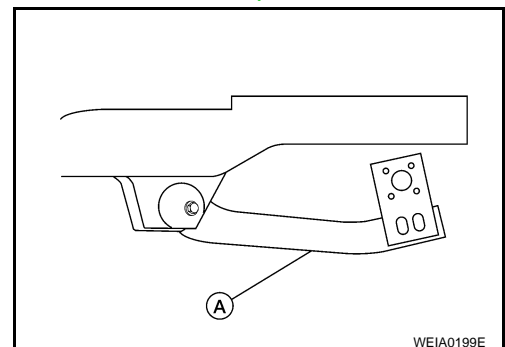

# SERVICE DATA AND SPECIFICATIONS (SDS)

< SERVICE INFORMATION >

## SERVICE DATA AND SPECIFICATIONS (SDS)

### Wheel Alignment (Unladen\*)

INFOID:000000004407372

Model		2.0, 2.0 S, 2.0 SL	SE-R	SPEC-V
Camber Degree minute (Decimal degree)	Minimum	- 2° 00' (- 2.00°)	- 2° 00' (- 2.00°)	- 2° 00' (- 2.00°)
	Nominal	- 1° 30' (- 1.50°)	- 1° 30' (- 1.50°)	- 1° 30' (- 1.50°)
	Maximum	- 1° 00' (- 1.00°)	- 1° 00' (- 1.00°)	- 1° 00' (- 1.00°)
Total toe-in Distance (A - B)	Minimum	- 3.0 mm (- 0.118 in)	- 2.0 mm (- 0.079 in)	- 1.0 mm (- 0.039 in)
	Nominal	1.0 mm (0.039 in)	2.0 mm (0.079 in)	3.0 mm (0.118 in)
	Maximum	5.0 mm (0.197 in)	6.0 mm (0.236 in)	7.0 mm (0.276 in)

\*: Fuel, engine coolant and engine oil full. Spare tire, jack, hand tools and mats in designated positions.

### Wheelarch Height (Unladen\*)

INFOID:000000004407373

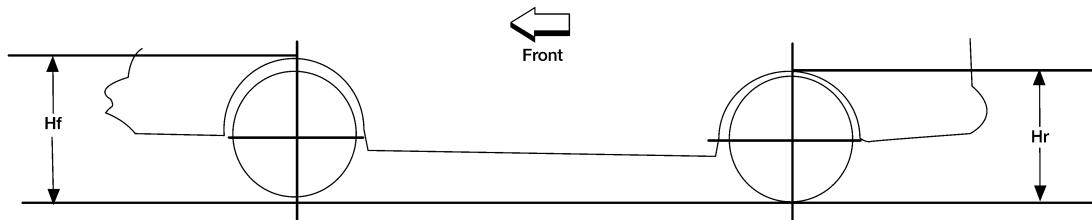

LEIA0085E

Engine	MR20DE		QR25DE	
Model	2.0	2.0 S, 2.0 SL	SE-R	SPEC-V
Tire Size	P205/60HR15	P205/55HR16	P225/45VR17	P225/45WR17
Front (Hf) mm (in)	691 (27.20)	694 (27.32)	690 (27.17)	679 (26.73)
Rear (Hr) mm (in)	693 (27.28)	696 (27.40)	690 (27.17)	677 (26.65)

\*: Fuel, radiator coolant and engine oil full. Spare tire, jack, hand tools and mats in designated positions.