

SECTION **RF**  
ROOF

A  
B  
C  
D  
E  
F  
G  
H  
RF  
J  
K  
L  
M  
N  
O  
P

CONTENTS

<b>SERVICE INFORMATION</b> .....	2	CAN Communication System Description .....	13
<b>PRECAUTIONS</b> .....	2	Wiring Diagram - SROOF - .....	14
Precaution for Supplemental Restraint System (SRS) "AIR BAG" and "SEAT BELT PRE-TENSIONER" .....	2	Terminal and Reference Value for BCM .....	15
Precaution Necessary for Steering Wheel Rotation After Battery Disconnect .....	2	Sunroof Motor Assembly Harness Connector Terminal Layout .....	16
Precaution .....	3	Terminal and Reference Value for Sunroof Motor Assembly .....	16
<b>PREPARATION</b> .....	4	Work Flow .....	16
Commercial Service Tool .....	4	CONSULT-III Function (BCM) .....	16
<b>SQUEAK AND RATTLE TROUBLE DIAGNOSIS</b> .....	5	Work Support .....	17
Work Flow .....	5	Active Test .....	17
Generic Squeak and Rattle Troubleshooting .....	7	Data Monitor .....	17
Diagnostic Worksheet .....	9	Trouble Diagnosis Chart by Symptom .....	17
<b>SUNROOF</b> .....	11	BCM Power Supply and Ground Circuit Inspection .....	18
Component Parts and Harness Connector Location .....	11	Sunroof Switch System Inspection .....	18
System Description .....	11	Sunroof Motor Assembly Power Supply and Ground Circuit Inspection .....	19
		Door Switch Check .....	20
		Removal and Installation .....	23
		Fitting Adjustment .....	27
		Inspection .....	28

# PRECAUTIONS

< SERVICE INFORMATION >

## SERVICE INFORMATION

### PRECAUTIONS

#### Precaution for Supplemental Restraint System (SRS) "AIR BAG" and "SEAT BELT PRE-TENSIONER"

INFOID:000000004777144

The Supplemental Restraint System such as "AIR BAG" and "SEAT BELT PRE-TENSIONER", used along with a front seat belt, helps to reduce the risk or severity of injury to the driver and front passenger for certain types of collision. This system includes seat belt switch inputs and dual stage front air bag modules. The SRS system uses the seat belt switches to determine the front air bag deployment, and may only deploy one front air bag, depending on the severity of a collision and whether the front occupants are belted or unbelted. Information necessary to service the system safely is included in the SRS and SB section of this Service Manual.

#### **WARNING:**

- To avoid rendering the SRS inoperative, which could increase the risk of personal injury or death in the event of a collision which would result in air bag inflation, all maintenance must be performed by an authorized NISSAN/INFINITI dealer.
- Improper maintenance, including incorrect removal and installation of the SRS can lead to personal injury caused by unintentional activation of the system. For removal of Spiral Cable and Air Bag Module, see the SRS section.
- Do not use electrical test equipment on any circuit related to the SRS unless instructed to in this Service Manual. SRS wiring harnesses can be identified by yellow and/or orange harnesses or harness connectors.
- When working near the Airbag Diagnosis Sensor Unit or other Airbag System sensors with the Ignition ON or engine running, DO NOT use air or electric power tools or strike near the sensor(s) with a hammer. Heavy vibration could activate the sensor(s) and deploy the air bag(s), possibly causing serious injury.
- When using air or electric power tools or hammers, always switch the Ignition OFF, disconnect the battery, and wait at least 3 minutes before performing any service.

#### Precaution Necessary for Steering Wheel Rotation After Battery Disconnect

INFOID:000000004777143

#### **NOTE:**

- This Procedure is applied only to models with Intelligent Key system and NATS (NISSAN ANTI-THEFT SYSTEM).
- Remove and install all control units after disconnecting both battery cables with the ignition knob in the "LOCK" position.
- Always use CONSULT-III to perform self-diagnosis as a part of each function inspection after finishing work. If DTC is detected, perform trouble diagnosis according to self-diagnostic results.

For models equipped with the Intelligent Key system and NATS, an electrically controlled steering lock mechanism is adopted on the key cylinder.

For this reason, if the battery is disconnected or if the battery is discharged, the steering wheel will lock and steering wheel rotation will become impossible.

If steering wheel rotation is required when battery power is interrupted, follow the procedure below before starting the repair operation.

#### OPERATION PROCEDURE

1. Connect both battery cables.

#### **NOTE:**

Supply power using jumper cables if battery is discharged.

2. Use the Intelligent Key or mechanical key to turn the ignition switch to the "ACC" position. At this time, the steering lock will be released.
3. Disconnect both battery cables. The steering lock will remain released and the steering wheel can be rotated.
4. Perform the necessary repair operation.
5. When the repair work is completed, return the ignition switch to the "LOCK" position before connecting the battery cables. (At this time, the steering lock mechanism will engage.)
6. Perform a self-diagnosis check of all control units using CONSULT-III.

# PRECAUTIONS

< SERVICE INFORMATION >

## Precaution

INFOID:000000004407834

- Disconnect both battery cables in advance.
- Do not tamper with or force air bag lid open, as this may adversely affect air bag performance.
- Be careful not to scratch pad and other parts.
- When removing or disassembling any part, be careful not to damage or deform it. Protect parts which may get in the way with cloth.
- When removing parts with a screwdriver or other tool, protect parts by wrapping them with vinyl or tape.
- Keep removed parts protected with cloth.
- If a clip is deformed or damaged, replace it.
- If an un reusable part is removed, replace it with a new one.
- Tighten bolts and nuts firmly to the specified torque.
- After re-assembly has been completed, make sure each part functions correctly.
- Remove stains in the following way.

Water-soluble stains:

Dip a soft cloth in warm water, and then squeeze it tightly. After wiping the stain, wipe with a soft dry cloth.

Oil stain:

Dissolve a synthetic detergent in warm water (density of 2 to 3% or less), dip the cloth, then clean off the stain with the cloth. Next, dip the cloth in fresh water and squeeze it tightly. Then clean off the detergent completely. Then wipe the area with a soft dry cloth.

- Do not use any organic solvent, such as thinner or benzine.

A

B

C

D

E

F

G

H

RF

J

K

L

M

N

O

P

# PREPARATION

< SERVICE INFORMATION >

## PREPARATION

### Commercial Service Tool

INFOID:000000004407835

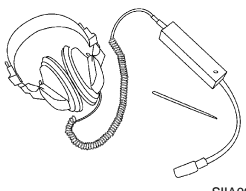
Tool name	Description
Engine ear  SIA0995E	Locating the noise

# SQUEAK AND RATTLE TROUBLE DIAGNOSIS

< SERVICE INFORMATION >

## SQUEAK AND RATTLE TROUBLE DIAGNOSIS

### Work Flow

INFOID:000000004407836

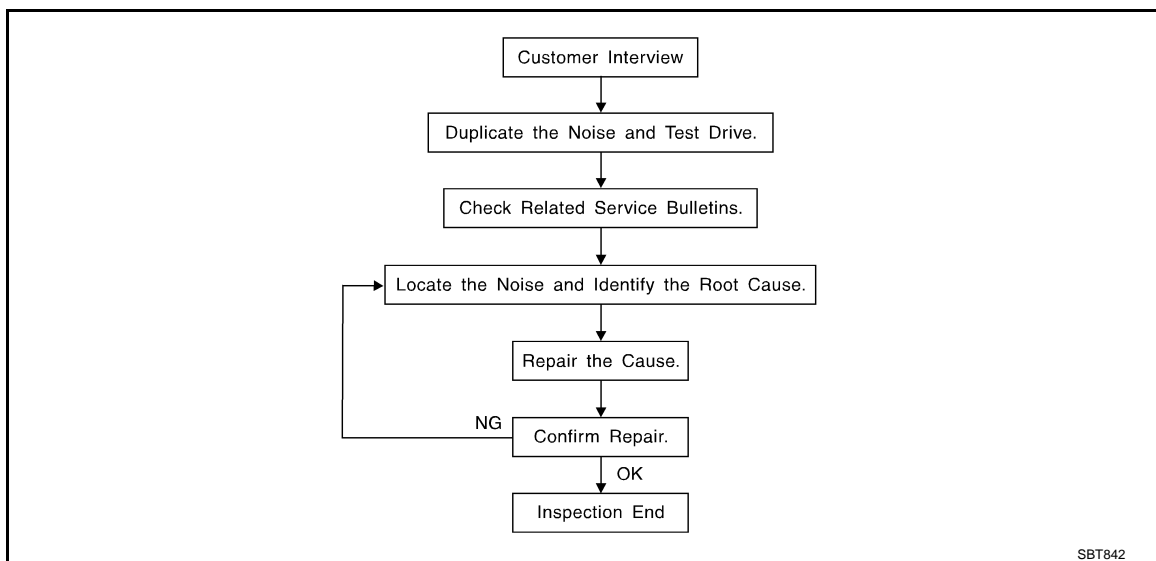

### CUSTOMER INTERVIEW

Interview the customer if possible, to determine the conditions that exist when the noise occurs. Use the Diagnostic Worksheet during the interview to document the facts and conditions when the noise occurs and any customer's comments; refer to [RF-9, "Diagnostic Worksheet"](#). This information is necessary to duplicate the conditions that exist when the noise occurs.

- The customer may not be able to provide a detailed description or the location of the noise. Attempt to obtain all the facts and conditions that exist when the noise occurs (or does not occur).
- If there is more than one noise in the vehicle, be sure to diagnose and repair the noise that the customer is concerned about. This can be accomplished by test driving the vehicle with the customer.
- After identifying the type of noise, isolate the noise in terms of its characteristics. The noise characteristics are provided so the customer, service adviser and technician are all speaking the same language when defining the noise.
- Squeak —(Like tennis shoes on a clean floor)  
Squeak characteristics include the light contact/fast movement/brought on by road conditions/hard surfaces = higher pitch noise/softer surfaces = lower pitch noises/edge to surface = chirping
- Creak—(Like walking on an old wooden floor)  
Creak characteristics include firm contact/slow movement/twisting with a rotational movement/pitch dependent on materials/often brought on by activity.
- Rattle—(Like shaking a baby rattle)  
Rattle characteristics include the fast repeated contact/vibration or similar movement/loose parts/missing clip or fastener/incorrect clearance.
- Knock —(Like a knock on a door)  
Knock characteristics include hollow sounding/sometimes repeating/often brought on by driver action.
- Tick—(Like a clock second hand)  
Tick characteristics include gentle contacting of light materials/loose components/can be caused by driver action or road conditions.
- Thump—(Heavy, muffled knock noise)  
Thump characteristics include softer knock/dead sound often brought on by activity.
- Buzz—(Like a bumble bee)  
Buzz characteristics include high frequency rattle/firm contact.
- Often the degree of acceptable noise level will vary depending upon the person. A noise that you may judge as acceptable may be very irritating to the customer.
- Weather conditions, especially humidity and temperature, may have a great effect on noise level.

### DUPLICATE THE NOISE AND TEST DRIVE

If possible, drive the vehicle with the customer until the noise is duplicated. Note any additional information on the Diagnostic Worksheet regarding the conditions or location of the noise. This information can be used to duplicate the same conditions when you confirm the repair.

# SQUEAK AND RATTLE TROUBLE DIAGNOSIS

## < SERVICE INFORMATION >

If the noise can be duplicated easily during the test drive, to help identify the source of the noise, try to duplicate the noise with the vehicle stopped by doing one or all of the following:

- 1) Close a door.
  - 2) Tap or push/pull around the area where the noise appears to be coming from.
  - 3) Rev the engine.
  - 4) Use a floor jack to recreate vehicle "twist".
  - 5) At idle, apply engine load (electrical load, half-clutch on M/T model, drive position on A/T model).
  - 6) Raise the vehicle on a hoist and hit a tire with a rubber hammer.
- Drive the vehicle and attempt to duplicate the conditions the customer states exist when the noise occurs.
  - If it is difficult to duplicate the noise, drive the vehicle slowly on an undulating or rough road to stress the vehicle body.

## CHECK RELATED SERVICE BULLETINS

After verifying the customer concern or symptom, check ASIST for Technical Service Bulletins (TSBs) related to that concern or symptom.

If a TSB relates to the symptom, follow the procedure to repair the noise.

## LOCATE THE NOISE AND IDENTIFY THE ROOT CAUSE

1. Narrow down the noise to a general area. To help pinpoint the source of the noise, use a listening tool (Engine Ear or mechanics stethoscope).
2. Narrow down the noise to a more specific area and identify the cause of the noise by:
  - removing the components in the area that you suspect the noise is coming from.  
Do not use too much force when removing clips and fasteners, otherwise clips and fastener can be broken or lost during the repair, resulting in the creation of new noise.
  - tapping or pushing/pulling the component that you suspect is causing the noise.  
Do not tap or push/pull the component with excessive force, otherwise the noise will be eliminated only temporarily.
  - feeling for a vibration with your hand by touching the component(s) that you suspect is (are) causing the noise.
  - placing a piece of paper between components that you suspect are causing the noise.
  - looking for loose components and contact marks.  
Refer to [RF-7. "Generic Squeak and Rattle Troubleshooting"](#).

## REPAIR THE CAUSE

- If the cause is a loose component, tighten the component securely.
- If the cause is insufficient clearance between components:
  - separate components by repositioning or loosening and retightening the component, if possible.
  - insulate components with a suitable insulator such as urethane pads, foam blocks, felt cloth tape or urethane tape are available through your authorized Nissan Parts Department.

### **CAUTION:**

**Do not use excessive force as many components are constructed of plastic and may be damaged.**

### **NOTE:**

Always check with the Parts Department for the latest parts information.

Each item can be ordered separately as needed.

URETHANE PADS [1.5 mm (0.059 in) thick]

Insulates connectors, harness, etc.

76268-9E005: 100 × 135 mm (3.94 × 5.31 in)/76884-71L01: 60 × 85 mm (2.36 × 3.35 in)/76884-71L02: 15 × 25 mm (0.59 × 0.98 in)

INSULATOR (Foam blocks)

Insulates components from contact. Can be used to fill space behind a panel.

73982-9E000: 45 mm (1.77 in) thick, 50 × 50 mm (1.97 × 1.97 in)/73982-50Y00: 10 mm (0.39 in) thick, 50 × 50 mm (1.97 × 1.97 in)

INSULATOR (Light foam block)

80845-71L00: 30 mm (1.18 in) thick, 30 × 50 mm (1.18 × 1.97 in)

FELT CLOTH TAPE

Used to insulate where movement does not occur. Ideal for instrument panel applications.

68370-4B000: 15 × 25 mm (0.59 × 0.98 in) pad/68239-13E00: 5 mm (0.20 in) wide tape roll

The following materials, not available through NISSAN Parts Department, can also be used to repair squeaks and rattles.

UHMW(TEFLON) TAPE

Insulates where slight movement is present. Ideal for instrument panel applications.

# SQUEAK AND RATTLE TROUBLE DIAGNOSIS

## < SERVICE INFORMATION >

### SILICONE GREASE

Used in place of UHMW tape that will be visible or not fit.

Note: Will only last a few months.

### SILICONE SPRAY

Use when grease cannot be applied.

### DUCT TAPE

Use to eliminate movement.

### CONFIRM THE REPAIR

Confirm that the cause of a noise is repaired by test driving the vehicle. Operate the vehicle under the same conditions as when the noise originally occurred. Refer to the notes on the Diagnostic Worksheet.

## Generic Squeak and Rattle Troubleshooting

INFOID:000000004407837

Refer to Table of Contents for specific component removal and installation information.

### INSTRUMENT PANEL

Most incidents are caused by contact and movement between:

1. The cluster lid A and instrument panel
2. Acrylic lens and combination meter housing
3. Instrument panel to front pillar garnish
4. Instrument panel to windshield
5. Instrument panel pins
6. Wiring harnesses behind the combination meter
7. A/C defroster duct and duct joint

These incidents can usually be located by tapping or moving the components to duplicate the noise or by pressing on the components while driving to stop the noise. Most of these incidents can be repaired by applying felt cloth tape or silicone spray (in hard to reach areas). Urethane pads can be used to insulate wiring harness.

#### **CAUTION:**

**Do not use silicone spray to isolate a squeak or rattle. If you saturate the area with silicone, you will not be able to recheck the repair.**

### CENTER CONSOLE

Components to pay attention to include:

1. Shifter assembly cover to finisher
2. A/C control unit and cluster lid C
3. Wiring harnesses behind audio and A/C control unit

The instrument panel repair and isolation procedures also apply to the center console.

### DOORS

Pay attention to the:

1. Finisher and inner panel making a slapping noise
2. Inside handle escutcheon to door finisher
3. Wiring harnesses tapping
4. Door striker out of alignment causing a popping noise on starts and stops

Tapping or moving the components or pressing on them while driving to duplicate the conditions can isolate many of these incidents. You can usually insulate the areas with felt cloth tape or insulator foam blocks from the NISSAN Squeak and Rattle Kit (J-43980) to repair the noise.

### TRUNK

Trunk noises are often caused by a loose jack or loose items put into the trunk by the owner.

In addition look for:

1. Trunk lid bumpers out of adjustment
2. Trunk lid striker out of adjustment
3. The trunk lid torsion bars knocking together
4. A loose license plate or bracket

A

B

C

D

E

F

G

H

RF

J

K

L

M

N

O

P

# SQUEAK AND RATTLE TROUBLE DIAGNOSIS

## < SERVICE INFORMATION >

---

Most of these incidents can be repaired by adjusting, securing or insulating the item(s) or component(s) causing the noise.

### SUNROOF/HEADLINING

Noises in the sunroof/headlining area can often be traced to one of the following:

1. Sunroof lid, rail, linkage or seals making a rattle or light knocking noise
2. Sun visor shaft shaking in the holder
3. Front or rear windshield touching headliner and squeaking

Again, pressing on the components to stop the noise while duplicating the conditions can isolate most of these incidents. Repairs usually consist of insulating with felt cloth tape.

### OVERHEAD CONSOLE (FRONT AND REAR)

Overhead console noises are often caused by the console panel clips not being engaged correctly. Most of these incidents are repaired by pushing up on the console at the clip locations until the clips engage.

In addition look for:

1. Loose harness or harness connectors.
2. Front console map/reading lamp lens loose.
3. Loose screws at console attachment points.

### SEATS

When isolating seat noise it's important to note the position the seat is in and the load placed on the seat when the noise is present. These conditions should be duplicated when verifying and isolating the cause of the noise.

Cause of seat noise include:

1. Headrest rods and holder
2. A squeak between the seat pad cushion and frame
3. The rear seatback lock and bracket

These noises can be isolated by moving or pressing on the suspected components while duplicating the conditions under which the noise occurs. Most of these incidents can be repaired by repositioning the component or applying urethane tape to the contact area.

### UNDERHOOD

Some interior noise may be caused by components under the hood or on the engine wall. The noise is then transmitted into the passenger compartment.

Causes of transmitted underhood noise include:

1. Any component installed on the engine wall
2. Components that pass through the engine wall
3. Engine wall mounts and connectors
4. Loose radiator pins
5. Hood bumpers out of adjustment
6. Hood striker out of adjustment

These noises can be difficult to isolate since they cannot be reached from the interior of the vehicle. The best method is to secure, move or insulate one component at a time and test drive the vehicle. Also, engine RPM or load can be changed to isolate the noise. Repairs can usually be made by moving, adjusting, securing, or insulating the component causing the noise.



# SQUEAK AND RATTLE TROUBLE DIAGNOSIS

< SERVICE INFORMATION >

## Diagnostic Worksheet

INFOID:000000004407838

Dear Customer:

We are concerned about your satisfaction with your vehicle. Repairing a squeak or rattle sometimes can be very difficult. To help us fix your vehicle right the first time, please take a moment to note the area of the vehicle where the squeak or rattle occurs and under what conditions. You may be asked to take a test drive with a service advisor or technician to ensure we confirm the noise you are hearing.

### SQUEAK & RATTLE DIAGNOSTIC WORKSHEET

#### I. WHERE DOES THE NOISE COME FROM? (circle the area of the vehicle)

The illustrations are for reference only, and may not reflect the actual configuration of your vehicle.

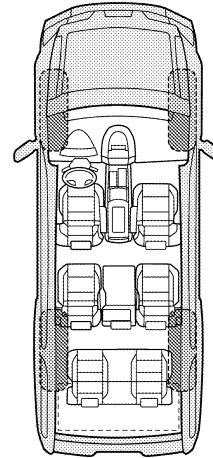
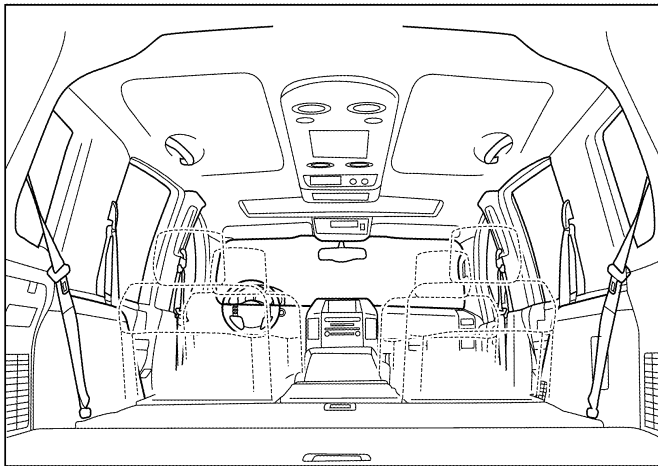
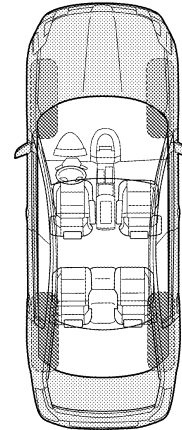
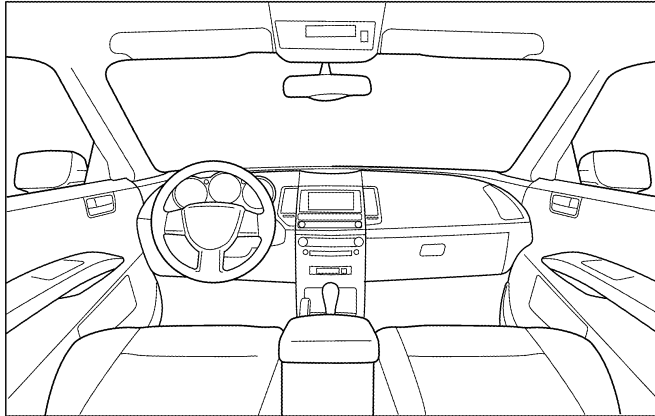

Continue to page 2 of the worksheet and briefly describe the location of the noise or rattle. In addition, please indicate the conditions which are present when the noise occurs.

A  
B  
C  
D  
E  
F  
G  
H  
RF  
J  
K  
L  
M  
N  
O  
P

# SQUEAK AND RATTLE TROUBLE DIAGNOSIS

< SERVICE INFORMATION >

## SQUEAK & RATTLE DIAGNOSTIC WORKSHEET - page 2

Briefly describe the location where the noise occurs:

---

---

### II. WHEN DOES IT OCCUR? (please check the boxes that apply)

- |                                                       |                                                        |
|-------------------------------------------------------|--------------------------------------------------------|
| <input type="checkbox"/> Anytime                      | <input type="checkbox"/> After sitting out in the rain |
| <input type="checkbox"/> 1st time in the morning      | <input type="checkbox"/> When it is raining or wet     |
| <input type="checkbox"/> Only when it is cold outside | <input type="checkbox"/> Dry or dusty conditions       |
| <input type="checkbox"/> Only when it is hot outside  | <input type="checkbox"/> Other:                        |

### III. WHEN DRIVING:

- Through driveways
- Over rough roads
- Over speed bumps
- Only about \_\_\_\_ mph
- On acceleration
- Coming to a stop
- On turns: left, right or either (circle)
- With passengers or cargo
- Other: \_\_\_\_\_
- After driving \_\_\_\_ miles or \_\_\_\_ minutes

### IV. WHAT TYPE OF NOISE

- Squeak (like tennis shoes on a clean floor)
- Creak (like walking on an old wooden floor)
- Rattle (like shaking a baby rattle)
- Knock (like a knock at the door)
- Tick (like a clock second hand)
- Thump (heavy muffled knock noise)
- Buzz (like a bumble bee)

### TO BE COMPLETED BY DEALERSHIP PERSONNEL

#### Test Drive Notes:

---

---

---

	YES	NO	Initials of person performing
Vehicle test driven with customer	<input type="checkbox"/>	<input type="checkbox"/>	_____
- Noise verified on test drive	<input type="checkbox"/>	<input type="checkbox"/>	_____
- Noise source located and repaired	<input type="checkbox"/>	<input type="checkbox"/>	_____
- Follow up test drive performed to confirm repair	<input type="checkbox"/>	<input type="checkbox"/>	_____

VIN: \_\_\_\_\_ Customer Name \_\_\_\_\_

W.O.# \_\_\_\_\_ Date: \_\_\_\_\_

This form must be attached to Work Order

LAI0071E

# SUNROOF

< SERVICE INFORMATION >

## SUNROOF

### Component Parts and Harness Connector Location

INFOID:000000004407839

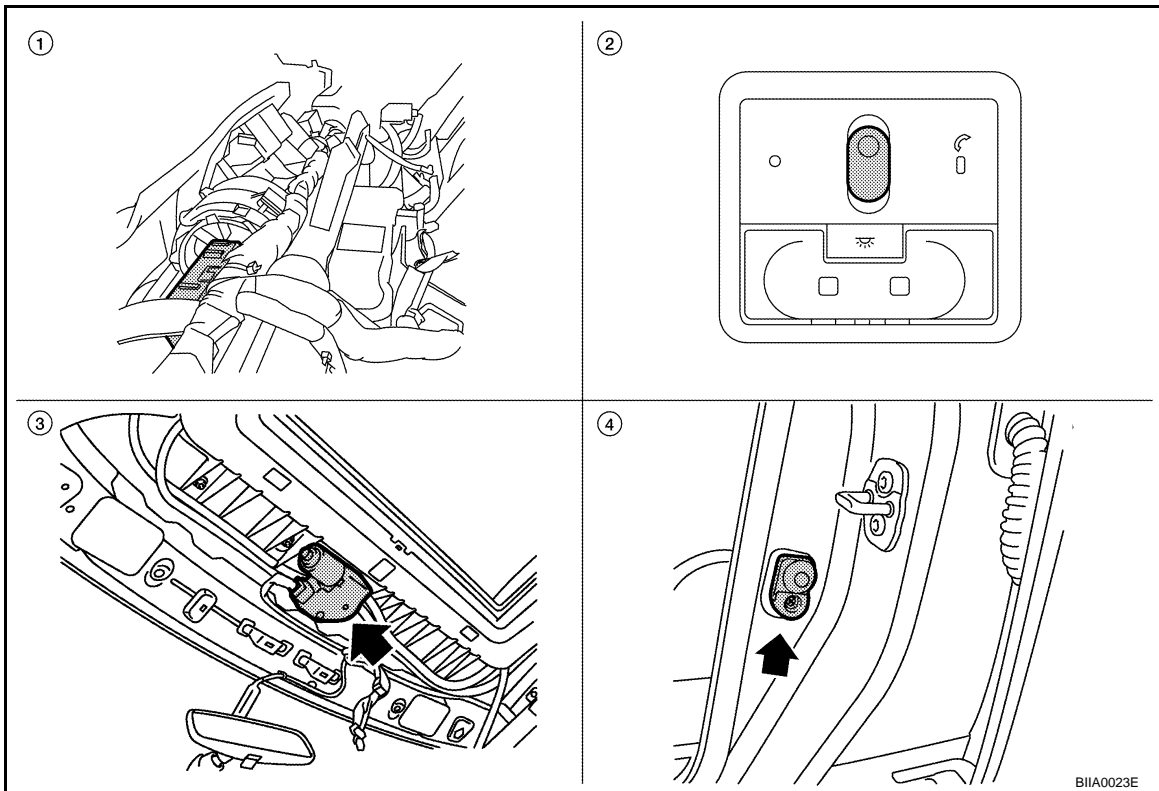

1. BCM M18, M19, M20 (view with instrument panel removed)
2. Sunroof switch R27
3. Sunroof motor assembly R26
4. Front door switch LH B21, RH B28

### System Description

INFOID:000000004407840

#### OUTLINE

Electric sunroof system consists of

- Sunroof switch
- Sunroof motor assembly
- BCM (body control module)

BCM supplies power to the sunroof motor. Sunroof operation depends on sunroof switch condition.

#### OPERATION

Power is supplied at all times

- through 50A fusible link (letter j, located in the fuse and fusible link box)
- to BCM terminal 70, and
- through BCM terminal 69
- to sunroof motor assembly terminal 7.

When the ignition switch is in the ON or START position, power is supplied

- through 10A fuse [No. 12, located in the fuse block (J/B)]
- to BCM terminal 38, and
- through BCM terminal 68
- to sunroof motor assembly terminal 9.

Ground is supplied

- to BCM terminal 67
- through grounds M57 and M61.

#### TILT UP/SLIDE CLOSE OPERATION

When up/close switch is pressed, ground is supplied

- to sunroof motor assembly terminal 1
- through sunroof switch terminal 3

A  
B  
C  
D  
E  
F  
G  
H

RF

J

K

L

M

N

O

P

# SUNROOF

## < SERVICE INFORMATION >

---

- through sunroof motor assembly terminal 10
- through sunroof switch terminal 2
- through grounds M57 and M61.

Then the sunroof will tilt up/slide closed.

### TILT DOWN/SLIDE OPEN OPERATION

When down/open switch is pressed, ground is supplied

- to sunroof motor assembly terminal 5
- through sunroof switch terminal 1
- through sunroof motor assembly terminal 10
- through sunroof switch terminal 2
- through grounds M57 and M61.

Then the sunroof will tilt down/slide open.

### AUTO OPERATION

The power sunroof AUTO feature makes it possible to slide open and slide closed or tilt up and tilt down the sunroof without holding the sunroof switch in the UP/CLOSE or DOWN/OPEN position.

### RETAINED POWER OPERATION

When the ignition switch is turned to OFF position from ON position, power is supplied for 45 seconds

- through BCM terminal 68
- to sunroof motor assembly terminal 9.

When power is supplied, the sunroof can be operated.

The retained power operation is canceled when the front door LH or RH is opened.

RAP signal period can be changed by CONSULT-III. Refer to [RF-17. "Work Support"](#).

### ANTI-PINCH FUNCTION

The CPU (central processing unit) of sunroof motor assembly monitors the sunroof motor operation and the sunroof position (fully-closed or other) by the signals from sunroof motor.

When sunroof motor detects an interruption during the following slide close and tilt down operation, sunroof switch controls the motor for open and the sunroof will operate until it reaches full up position (during tilt down operation) or 125 mm (4.92 in) or more in an open direction (during slide close operation).

- close operation and tilt down when ignition switch is in the ON position.
- close operation and tilt down during retained power operation.

### INITIALIZATION FAILURE CONDITIONS

Initialization and teaching of system should be conducted if the following conditions exist:

- sunroof will only move in the UP/CLOSE direction, having a step by step motion
- sunroof does not have any auto operation.

### INITIALIZATION PROCEDURE

If the sunroof does not close or open automatically, use the following procedure to return sunroof operation to normal.

1. Press the switch to the UP/CLOSE position to tilt the sunroof up fully. When the sunroof reaches the full tilt up position it will back up a few millimeters and stop.
2. Release the UP/CLOSE switch.
3. Within 5 seconds of releasing the UP/CLOSE switch, press and hold the UP/CLOSE switch again. The sunroof will move to the full open position and back to the closed position.

### NOTE:

If the UP/CLOSE switch is released anytime during this teaching process, all learned profile data will be discarded and the procedure will have to be started over.

4. Release the UP/CLOSE switch. Do not disconnect power for at least two seconds. The sunroof is now initialized and taught.

Initializing procedure is complete. Confirm proper operation of the sunroof (slide open, slide closed, tilt up, tilt down).

### RE-TEACHING CONDITIONS

Re-teaching of system should be conducted if any of the following conditions exist:

- the sunroof is manually operated using the sunroof wrench with the battery discharged or disconnected.
- the sunroof is manually operated using the sunroof wrench with the key switch in the OFF position and retained power timed out (after approximately 45 seconds or with a front door open).
- the sunroof motor assembly is replaced with a new one.
- the sunroof motor is removed from the sunroof assembly and operated before it is reinstalled.

# SUNROOF

## < SERVICE INFORMATION >

---

- the sunroof motor is removed from the sunroof assembly and the glass panel position is changed.

### RE-TEACHING PROCEDURE

1. Using the UP/CLOSE switch, move the sunroof toward the tilt position until it stops.
2. Release the UP/CLOSE switch.
3. Press the UP/CLOSE switch again and continuously hold. The sunroof will begin to move in about 10 seconds.
4. Continue to hold the UP/CLOSE switch while the sunroof moves in a jogging motion to the full tilt position. When the sunroof reaches the full tilt position, it will back up a few millimeters and stop.
5. Release the UP/CLOSE switch.
6. Within 5 seconds of releasing the UP/CLOSE switch, press and hold the UP/CLOSE switch again. The sunroof will move to the full open position and back to the closed position.

### NOTE:

If the UP/CLOSE switch is released anytime during this teaching process, all learned profile data will be discarded and the procedure will have to be started over.

7. Release the UP/CLOSE switch. Do not disconnect power for at least two seconds. The sunroof is now re-taught.

### CAN Communication System Description

INFOID:000000004407841

Refer to [LAN-6, "System Description"](#).

A  
B  
C  
D  
E  
F  
G  
H  
J  
K  
L  
M  
N  
O  
P

RF

# SUNROOF

< SERVICE INFORMATION >

## Wiring Diagram - SROOF -

INFOID:000000004407842

### RF-SROOF-01

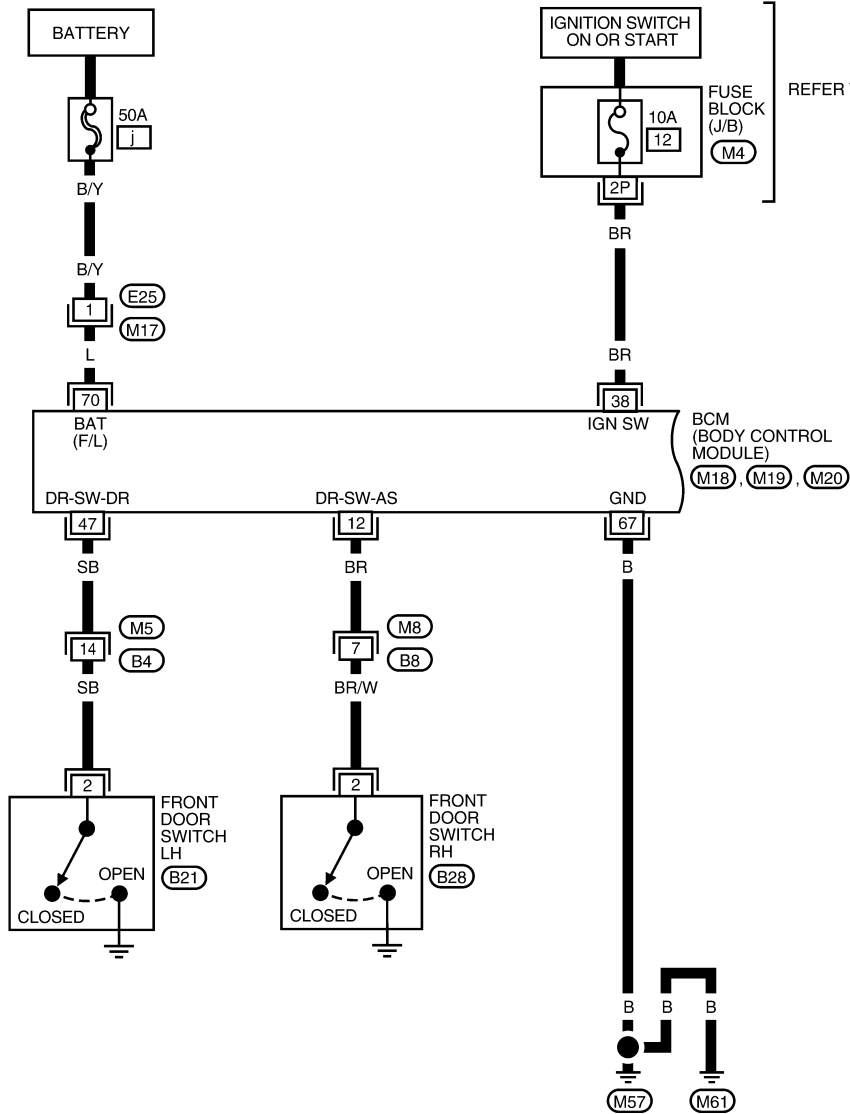

REFER TO "PG-POWER".

1P	2P	3P	4P	5P	6P	7P	M4	1	2	3	4	5	6	7	M5	M8	1	M17					
8P	9P	10P	11P	12P	13P	14P	15P	16P	W	8	9	10	11	12	13	14	15	16	GR	W	2	3	W

1	2	3	4	5	6	7	8	9	10	11	12	13	14	15	16	17	18	19	20	M18	41	42	43	44	45	46	47	48	49	M19	56	57	58	59	60	61	62	63	64	M20	H.S.
21	22	23	24	25	26	27	28	29	30	31	32	33	34	35	36	37	38	39	40	W	50	51	52	53	54	55	W	65	66	67	68	69	70	B							

1		
2	B21	B28
3	W	W

WIWA2162E

# SUNROOF

< SERVICE INFORMATION >

RF-SROOF-02

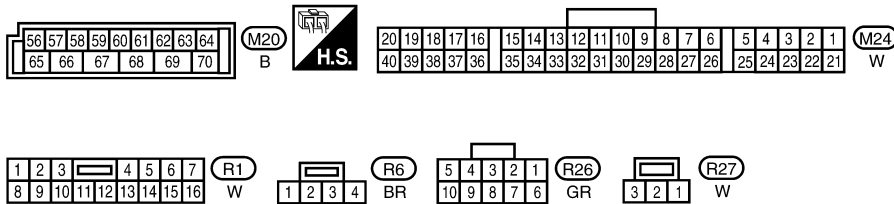
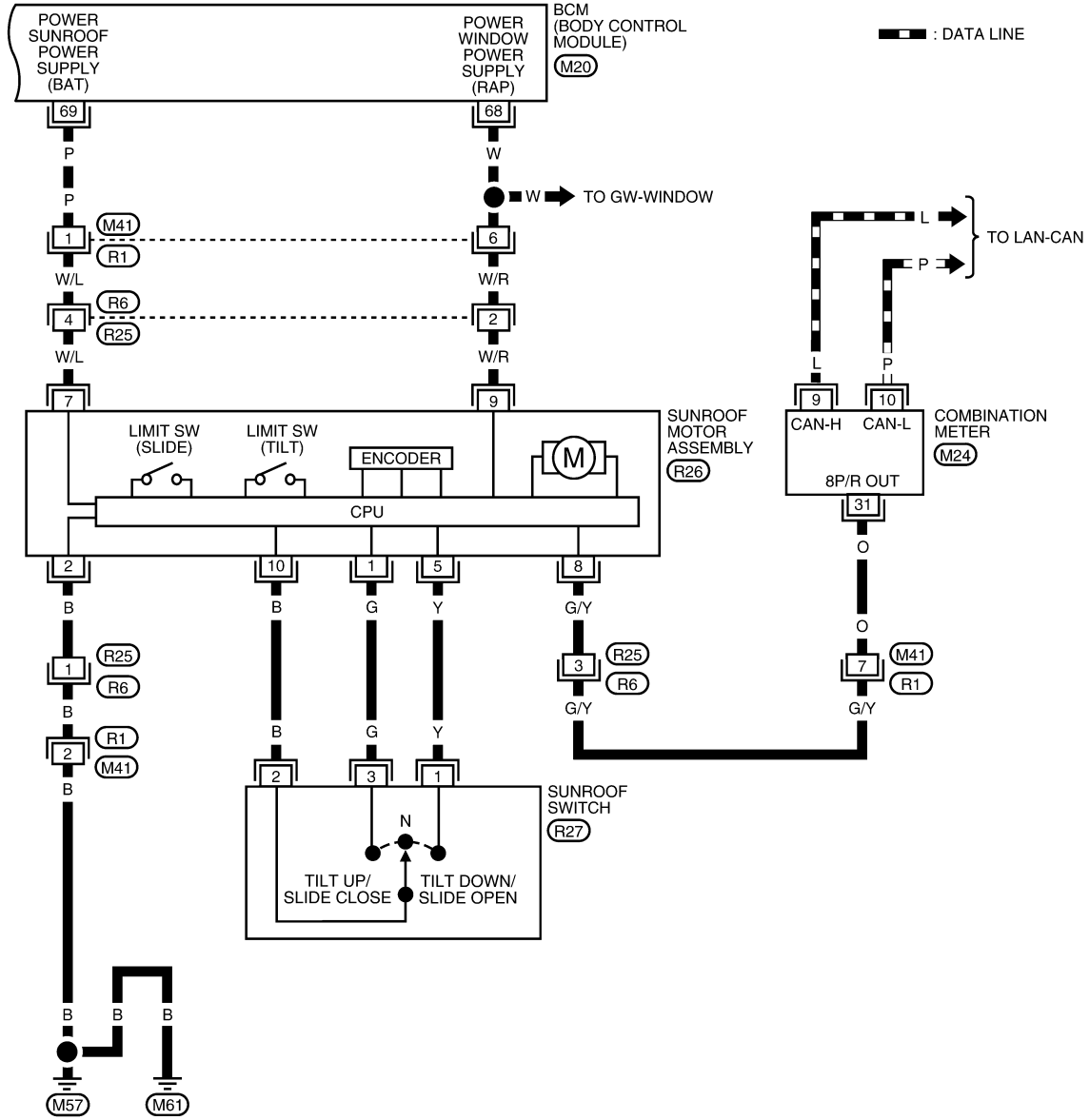

WIWA2163E

Terminal and Reference Value for BCM

Refer to [BCS-11, "Terminal and Reference Value for BCM"](#).

INFOID:000000004407843

# SUNROOF

< SERVICE INFORMATION >

## Sunroof Motor Assembly Harness Connector Terminal Layout

INFOID:000000004407844

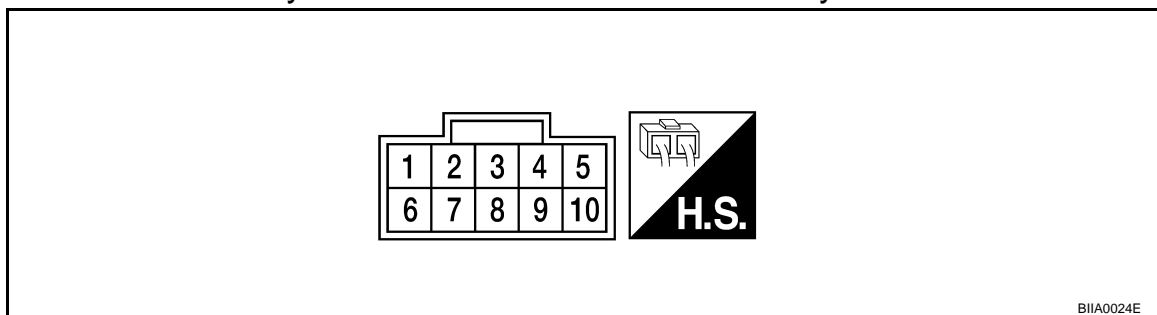

B1IA0024E

## Terminal and Reference Value for Sunroof Motor Assembly

INFOID:000000004407845

Terminal	Wire color	Item	Condition	Voltage (Approx.)
1	G	Sunroof switch (UP/CLOSE) signal	Ignition switch ON and sunroof switch in UP/CLOSE position	0
			Ignition switch ON and sunroof switch in OFF position	Battery voltage
2	B	Ground	—	0
5	Y	Sunroof switch (DOWN/OPEN) signal	Ignition switch ON and sunroof switch in DOWN/OPEN position	0
			Ignition switch ON and sunroof switch in OFF position	Battery voltage
7	W/L	BAT power supply	—	Battery voltage
8	G/Y	Vehicle speed signal	Speedometer operated [when vehicle speed is approx. 40 km/h (25 MPH)]	<p>ELF1080D</p>
9	W/R	RAP signal	Ignition switch ON	Battery voltage
			Within 45 seconds after ignition switch is turned OFF	Battery voltage
			When front door LH or RH is opened while retained power is operating	0
10	B	Ground	—	0

## Work Flow

INFOID:000000004407846

1. Check the symptom and customer's requests.
2. Understand the outline of system. Refer to [RF-11, "System Description"](#).
3. According to the trouble diagnosis chart, repair or replace the cause of the malfunction. Refer to [RF-17, "Trouble Diagnosis Chart by Symptom"](#).
4. Does sunroof system operate normally? If Yes, GO TO 5. If No, GO TO 3.
5. Inspection End.

## CONSULT-III Function (BCM)

INFOID:000000004407847

CONSULT-III can display each diagnostic item using the diagnostic test modes shown following.



# SUNROOF

## < SERVICE INFORMATION >

BCM diagnostic test item	Diagnostic mode	Description
Inspection by part	WORK SUPPORT	Supports inspections and adjustments. Commands are transmitted to the BCM for setting the status suitable for required operation, input/output signals are received from the BCM and received data is displayed.
	DATA MONITOR	Displays BCM input/output data in real time.
	ACTIVE TEST	Operation of electrical loads can be checked by sending drive signal to them.
	SELF-DIAG RESULTS	Displays BCM self-diagnosis results.
	CAN DIAG SUPPORT MNTR	The result of transmit/receive diagnosis of CAN communication can be read.
	ECU PART NUMBER	BCM part number can be read.
	CONFIGURATION	Performs BCM configuration read/write functions.

### Work Support

INFOID:000000004407848

Work item	Description
RETAINED PWR SET	RAP signal's power supply period can be changed by mode setting. Selects RAP signal's power supply period between the following three steps. • MODE 1 (45 sec.) / MODE 2 (OFF) / MODE 3 (2 min.)

### Active Test

INFOID:000000004407849

Test item	Description
RETAINED PWR	This test is able to supply RAP signal (power) from BCM to power window system, power sunroof system. Those systems can be operated when turning on "RETAINED PWR" on CONSULT-III screen even if the ignition switch is turned OFF. <b>NOTE:</b> <b>During this test, CONSULT-III can be operated with ignition switch in "OFF" position. "RETAINED PWR" should be turned "ON" or "OFF" on CONSULT-III screen when ignition switch ON. Then turn ignition switch OFF for checking retained power operation. CONSULT-III might be stuck if "RETAINED PWR" is turned "ON" or "OFF" on CONSULT-III screen when ignition switch is OFF.</b>

### Data Monitor

INFOID:000000004407850

Monitored item	Description
IGN ON SW	Indicates [ON/OFF] condition of ignition switch.
DOOR SW-DR	Indicates [ON/OFF] condition of front door switch LH.
DOOR SW-AS	Indicates [ON/OFF] condition of front door switch RH.

### Trouble Diagnosis Chart by Symptom

INFOID:000000004407851

Symptom	Diagnostic procedure and repair order	Refer to page
Sunroof does not operate.	1. BCM power supply and ground circuit check	<a href="#">BCS-14</a>
	2. Sunroof motor assembly power supply and ground circuit check	<a href="#">RF-19</a>
	3. Sunroof switch system check	<a href="#">RF-18</a>
	4. Replace sunroof motor assembly	<a href="#">RF-23</a>
Motor does not stop at the sunroof fully-open or fully-closed position.	1. Initialization procedure check	<a href="#">RF-11</a>
	2. Replace sunroof motor assembly	<a href="#">RF-23</a>

# SUNROOF

## < SERVICE INFORMATION >

Symptom	Diagnostic procedure and repair order	Refer to page
Retained power operation does not operate properly.	1. Check the retained power operation mode setting	<a href="#">RF-17</a>
	2. BCM power supply and ground circuit check	<a href="#">BCS-14</a>
	3. Door switch check	<a href="#">RF-20</a>
	4. Replace sunroof motor assembly	<a href="#">RF-23</a>
Sunroof does not do the interruption detection.	1. Replace sunroof motor assembly	<a href="#">RF-23</a>

## BCM Power Supply and Ground Circuit Inspection

INFOID:000000004407852

Refer to [BCS-14. "BCM Power Supply and Ground Circuit Inspection"](#).

## Sunroof Switch System Inspection

INFOID:000000004407853

### 1. SUNROOF SWITCH INPUT SIGNAL CHECK

- Turn ignition switch ON.
- Check voltage between sunroof motor assembly connector and ground.

Connector	Terminal		Condition	Voltage (Approx.)
	(+)	(-)		
R26	1	Ground	Sunroof switch is operated to UP/CLOSE	0
			Other than above	Battery voltage
	5		Sunroof switch is operated to DOWN/OPEN	0
			Other than above	Battery voltage

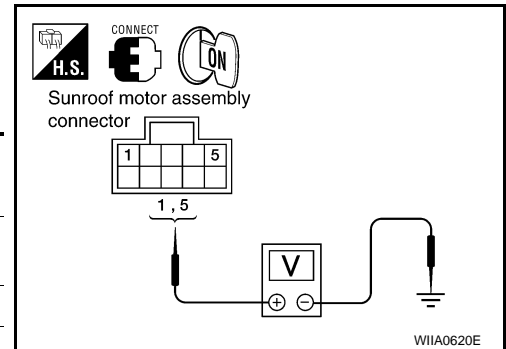

#### OK or NG

- OK >> Sunroof switch input signal circuits are OK.  
 NG >> GO TO 2.

### 2. SUNROOF SWITCH CIRCUIT CHECK

- Turn ignition switch OFF.
- Disconnect sunroof motor assembly and sunroof switch.
- Check continuity between sunroof motor assembly connector R26 terminals 1, 5 and sunroof switch connector R27 terminals 1, 3.

**1 - 3 : Continuity should exist.**

**5 - 1 : Continuity should exist.**

- Check continuity between sunroof motor assembly connector R26 terminals 1, 5 and ground.

**1 - Ground : Continuity should not exist.**

**5 - Ground : Continuity should not exist.**

#### OK or NG

- OK >> GO TO 3.  
 NG >> Repair or replace harness.

### 3. SUNROOF SWITCH GROUND CIRCUIT CHECK

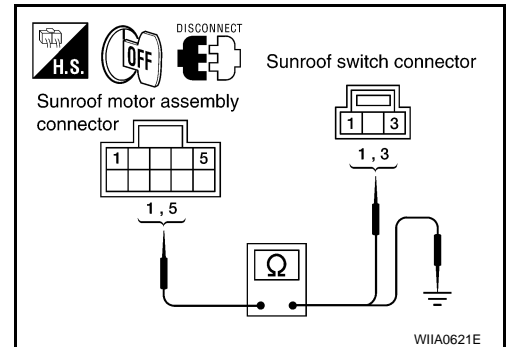

# SUNROOF

## < SERVICE INFORMATION >

Check continuity between sunroof switch connector R27 terminal 2 and ground.

**2 - Ground : Continuity should exist.**

OK or NG

- OK >> GO TO 4.
- NG >> Repair or replace harness.

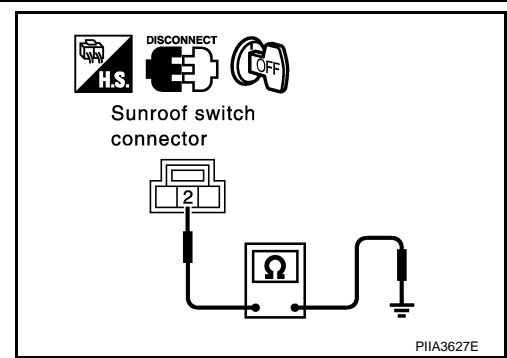

## 4. SUNROOF SWITCH CHECK

Check continuity between sunroof switch terminals 1, 3 and 2.

Terminals	Condition	Continuity
1	Sunroof switch is operated to DOWN/OPEN	Yes
	Other than above	No
3	Sunroof switch is operated to UP/CLOSE	Yes
	Other than above	No

OK or NG

- OK >> Replace sunroof motor assembly. Refer to [RF-23, "Removal and Installation"](#).
- NG >> Replace sunroof switch.

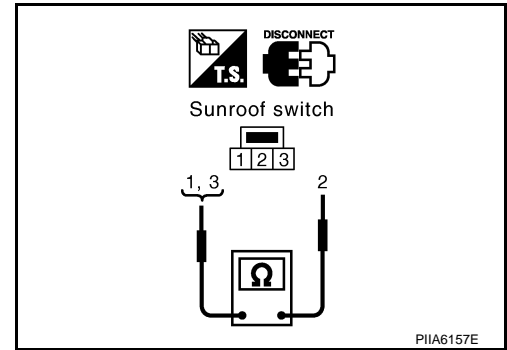

## Sunroof Motor Assembly Power Supply and Ground Circuit Inspection

INFOID:000000004407854

RF

### 1. CHECK POWER SUPPLY CIRCUIT

1. Turn ignition switch ON.
2. Check voltage between sunroof motor assembly connector R26 terminals 7, 9 and ground.

**7 - Ground : Battery voltage**

**9 - Ground : Battery voltage**

OK or NG

- OK >> GO TO 2.
- NG >> GO TO 3.

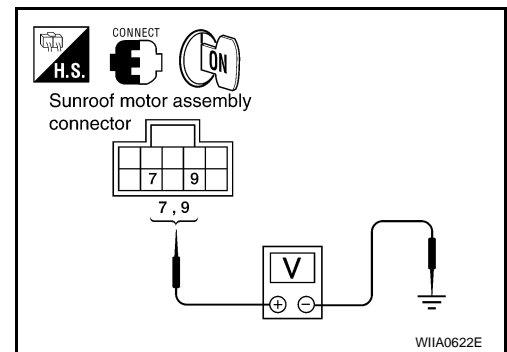

### 2. CHECK GROUND CIRCUIT

1. Turn ignition switch OFF.
2. Disconnect sunroof motor assembly.
3. Check continuity between sunroof motor assembly connector R26 terminal 2 and ground.

**2 - Ground : Continuity should exist.**

OK or NG

- OK >> Sunroof motor assembly power supply and ground circuits are OK. Further inspection is necessary. Refer to [RF-17, "Trouble Diagnosis Chart by Symptom"](#).
- NG >> Repair or replace harness.

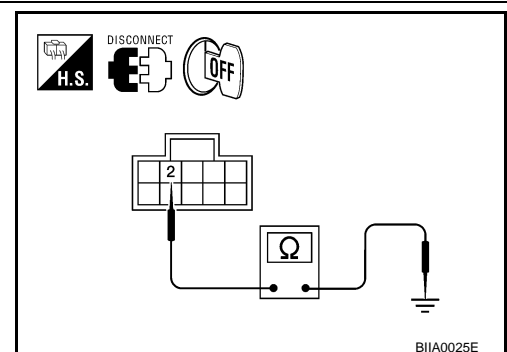

### 3. CHECK GROUND OUTPUT CIRCUIT

# SUNROOF

## < SERVICE INFORMATION >

1. Turn ignition switch OFF.
2. Disconnect sunroof motor assembly and sunroof switch.
3. Check continuity between sunroof motor assembly connector R26 (A) terminal 10 and sunroof switch connector R27 (B) terminal 2.

**2 - Ground** : **Continuity should exist.**

### OK or NG

- OK >> GO TO 4.  
 NG >> Repair or replace harness.

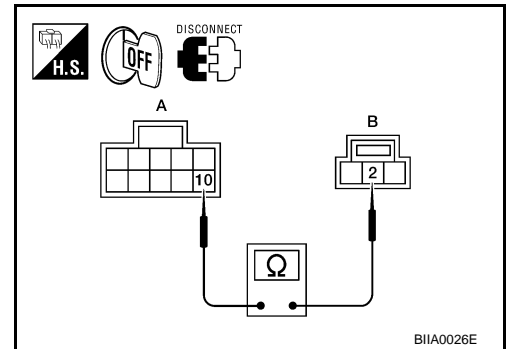

## 4.CHECK BCM OUTPUT SIGNAL

1. Turn ignition switch ON.
2. Check voltage between BCM connector M20 terminals 68, 69 and ground.

**68 - Ground** : **Battery voltage**

**69 - Ground** : **Battery voltage**

### OK or NG

- OK >> GO TO 5.  
 NG >> Replace BCM. Refer to [BCS-17. "Removal and Installation of BCM"](#).

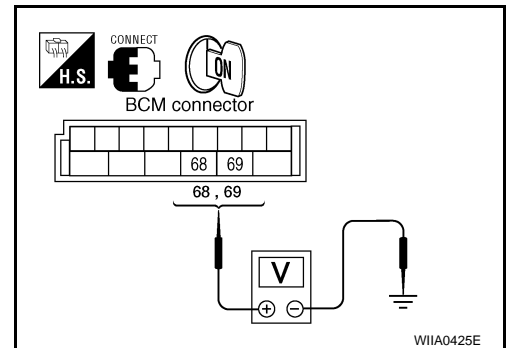

## 5.CHECK SUNROOF MOTOR CIRCUIT

1. Turn ignition switch OFF.
2. Disconnect BCM and sunroof motor assembly connectors.
3. Check continuity between BCM connector M20 terminals 68, 69 and sunroof motor assembly connector R26 terminals 7, 9.

**68 - 9** : **Continuity should exist.**

**69 - 7** : **Continuity should exist.**

4. Check continuity between BCM connector M20 terminals 68, 69 and ground.

**68 - Ground** : **Continuity should not exist.**

**69 - Ground** : **Continuity should not exist.**

### OK or NG

- OK >> Sunroof motor assembly power supply circuits are OK. Further inspection is necessary. Refer to [RF-17. "Trouble Diagnosis Chart by Symptom"](#).  
 NG >> Repair or replace harness.

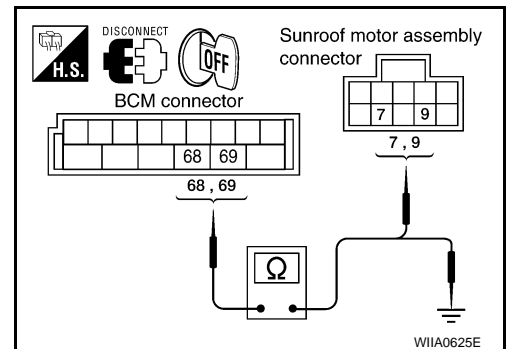

## Door Switch Check

INFOID:000000004407855

### 1.CHECK DOOR SWITCH INPUT SIGNAL

#### With CONSULT-III

Check ("DOOR SW-DR" and "DOOR SW-AS") in BCM "DATA MONITOR" mode with CONSULT-III.

Monitor item	Condition
DOOR SW-DR	DOOR OPEN: ON
	DOOR CLOSED: OFF
DOOR SW-AS	DOOR OPEN: ON
	DOOR CLOSED: OFF

# SUNROOF

## < SERVICE INFORMATION >

### ⊗ Without CONSULT-III

Check voltage between BCM connector M18, M19 terminals 12, 47 and ground.

Item	Terminal		Condition	Voltage (Approx.)
	(+)	(-)		
Front door switch RH	12	Ground	DOOR OPEN (Switch closed)	0
			DOOR CLOSED (Switch open)	Battery voltage
Front door switch LH	47		DOOR OPEN (Switch closed)	0
			DOOR CLOSED (Switch open)	Battery voltage

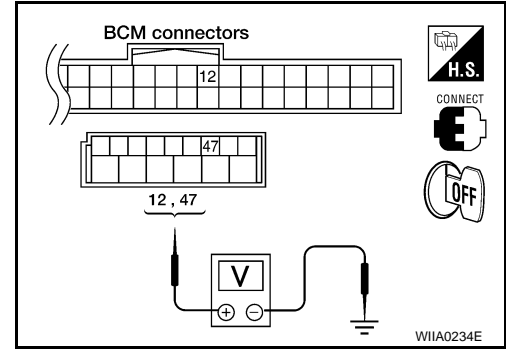

### OK or NG

- OK >> Door switch circuit is OK.
- NG >> GO TO 2.

## 2. CHECK DOOR SWITCH CIRCUIT

1. Turn ignition switch OFF.
2. Disconnect door switch and BCM.
3. Check continuity between BCM connector M18, M19 terminals 12, 47 and door switch connectors B8, B108 terminal 2.

### Front door LH

47 - 2 : Continuity should exist.

### Front door RH

12 - 2 : Continuity should exist.

4. Check continuity between BCM connector M18, M19 terminals 12, 47 and ground.

12 - Ground : Continuity should not exist.

47 - Ground : Continuity should not exist.

### OK or NG

- OK >> GO TO 3.
- NG >> Repair or replace harness.

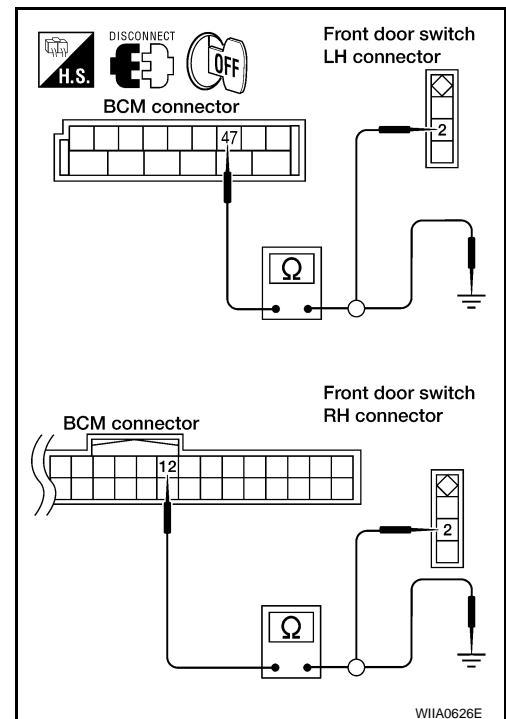

## 3. CHECK DOOR SWITCH

Check continuity between door switches terminal 2 and ground part of door switch.

Terminal	Door switch	Continuity
2	Ground part of door switch	No
	Released	Yes

### OK or NG

- OK >> GO TO 4.
- NG >> Replace malfunctioning door switch.

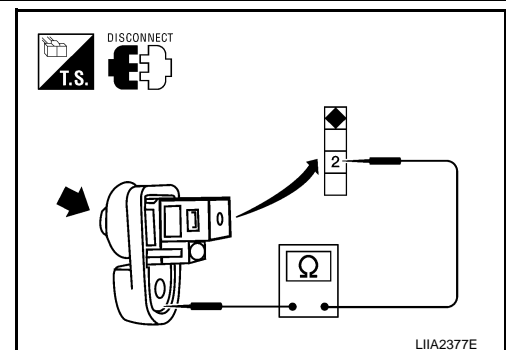

## 4. CHECK BCM OUTPUT SIGNAL

A  
B  
C  
D  
E  
F  
G  
H  
RF  
J  
K  
L  
M  
N  
O  
P

# SUNROOF

## < SERVICE INFORMATION >

1. Connect BCM.
2. Check voltage between BCM connector M18, M19 terminals 12, 47 and ground.

**12 - Ground : Battery voltage**

**47 - Ground : Battery voltage**

### OK or NG

- OK >> Further inspection is necessary. Refer to [RF-17, "Trouble Diagnosis Chart by Symptom"](#).
- NG >> Replace BCM. Refer to [BCS-17, "Removal and Installation of BCM"](#).

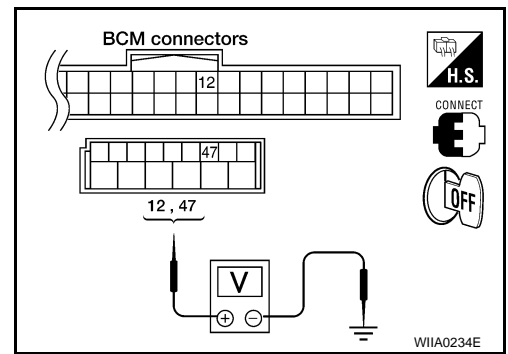

# SUNROOF

< SERVICE INFORMATION >

## Removal and Installation

INFOID:000000004407856

SEC. 736

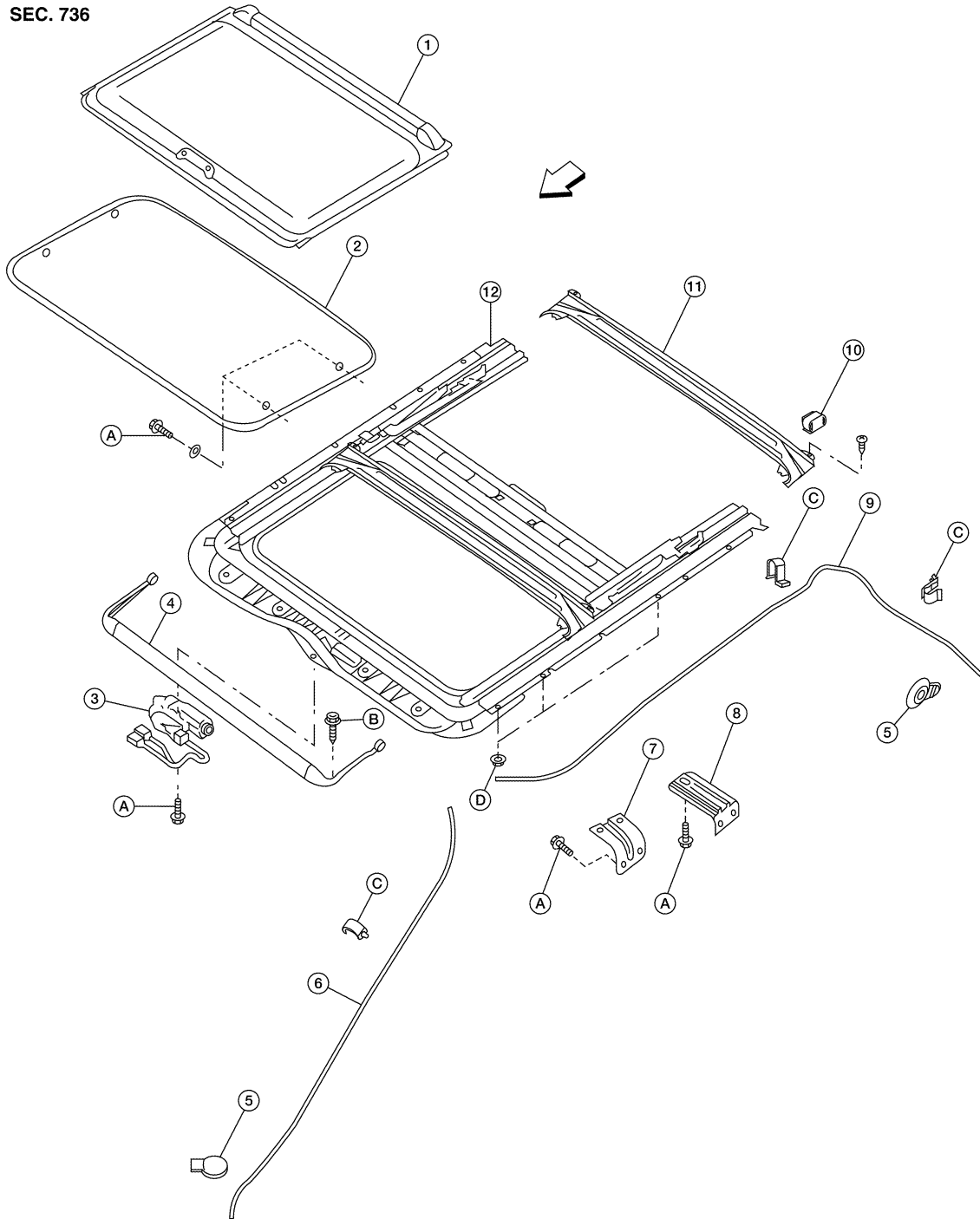

- |                       |                         |                           |
|-----------------------|-------------------------|---------------------------|
| 1. Sunshade           | 2. Glass lid            | 3. Sunroof motor assembly |
| 4. Wind deflector     | 5. Drain hose plug      | 6. Drain hose front       |
| 7. Front side bracket | 8. Rear side bracket    | 9. Drain hose rear        |
| 10. Sunshade stopper  | 11. Rear drain assembly | 12. Sunroof unit assembly |
| A. Bolt               | B. Screw                | C. Drain hose clip        |
| D. Nut                | ← Vehicle front         |                           |

**CAUTION:**

- After installation or any adjustment, check clearances for sunroof operation and glass lid alignment.

A  
B  
C  
D  
E  
F  
G  
H  
RF  
J  
K  
L  
M  
N  
O

LIA2856E

# SUNROOF

## < SERVICE INFORMATION >

- Handle glass lid with care to prevent damage.
- Fully close the glass lid before removal, then do not operate sunroof motor assembly after removal.
- When removing sunroof unit assembly, use shop cloths to protect the seats and trim from damage.
- Always work with a helper.

### NOTE:

For easy installation, mark each point before removal.

## SUNROOF UNIT ASSEMBLY

### Removal

1. Tilt glass lid up, then remove. Follow the GLASS LID procedure.
2. Position sunroof unit assembly to the fully closed position.
3. Remove the headlining. Refer to [EI-40](#).
4. Disconnect front and rear drain hoses.
5. Remove the bolts, then disconnect the sunroof motor assembly.

### NOTE:

- Before removing sunroof motor assembly, make sure that sunroof is fully closed.
- After removing sunroof motor assembly, do not attempt to rotate sunroof motor as a single unit.

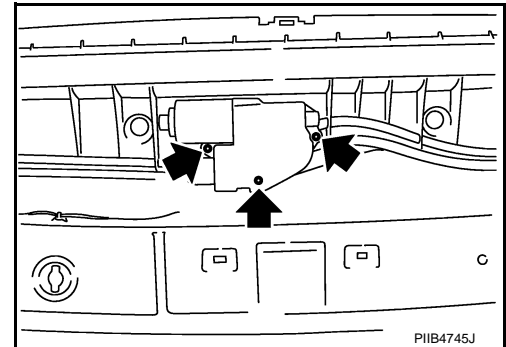

6. Remove the side and front sunroof unit assembly nuts.

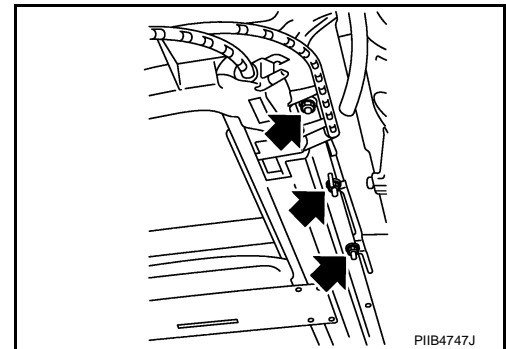

7. Remove sunroof front and rear side bracket bolts, then remove sunroof unit assembly from roof panel.
  - Remove sunroof unit assembly through the passenger compartment.

### CAUTION:

**Use care during removal and installation to avoid damage to seats and trim.**

### Installation

1. Install sunroof front and rear side brackets and bolts to the roof panel side only, but do not tighten.
2. Bring sunroof unit assembly into passenger compartment and position it so the rear rests on the sunroof rear side brackets.
3. Install sunroof front and rear side bracket bolts to the sunroof unit assembly side, but do not tighten.



# SUNROOF

## < SERVICE INFORMATION >

4. Install the front and side sunroof unit assembly nuts, but do not tighten.

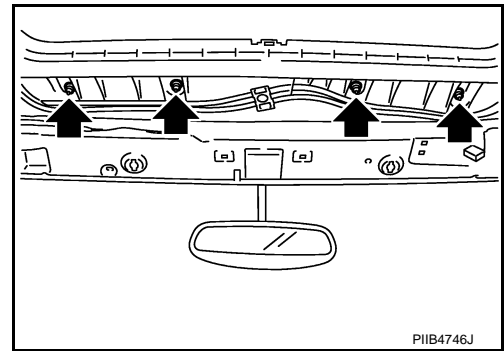

5. Tighten the sunroof unit assembly.
  - a. First, tighten the sunroof front and rear side bracket bolts at the vehicle side, then tighten the bolt on the rail side.
  - b. Next, tighten the front and side sunroof unit assembly nuts diagonally.
7. Connect the sunroof motor assembly connector and install the bolts.

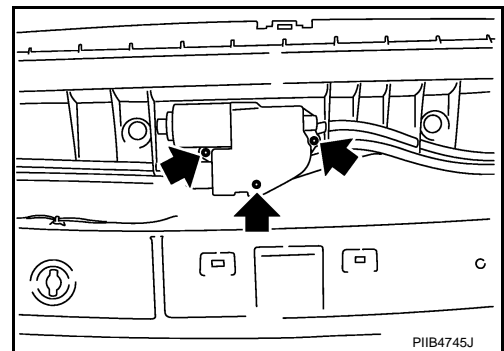

8. Install the glass lid. Follow the GLASS LID procedure.
9. Connect drain hoses.
10. Install headlining. Refer to [EI-40](#).
11. Perform fitting adjustment and test for leaks, refer to [RF-27. "Fitting Adjustment"](#).

## GLASS LID

### Removal

1. Open the sunshade fully and close the glass lid.
2. Remove glass lid bolts, then remove glass lid.

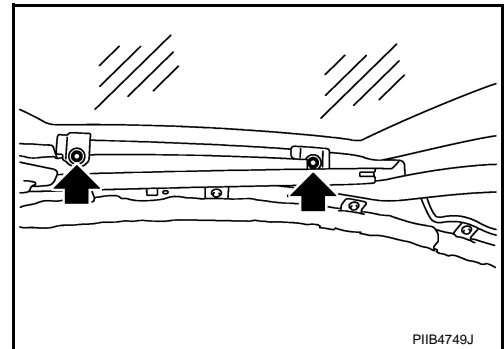

### Installation

1. Position the glass lid on sunroof unit assembly.
2. Partially install glass lid bolts. Tighten left front bolt first, then right rear to prevent uneven torque while tightening remaining bolts.
3. After installation, check sunroof operation and glass lid assembly alignment. Refer to [RF-27. "Fitting Adjustment"](#).

## SUNSHADE

### Removal

# SUNROOF

## < SERVICE INFORMATION >

1. Remove the headlining. Refer to [EI-40](#).
2. Remove sunshade stopper RH/LH.
3. Pull sunshade out rear of sunroof frame to remove it from sunroof unit assembly frame.

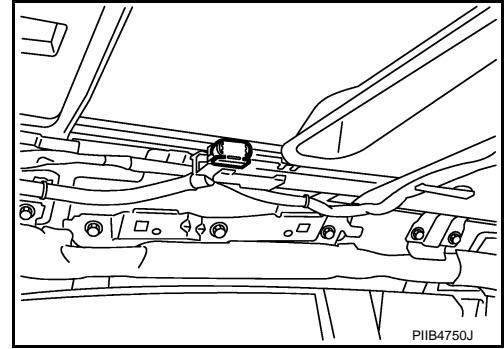

### Installation

Installation is in the reverse order of removal.

## WIND DEFLECTOR

### Removal

1. Open the glass lid.
2. Remove spring retainer screws RH/LH, then slide retainer forward in vehicle out of sunroof unit assembly channel.
3. Lift wind deflector and rotate arms upward to release from sunroof unit assembly.

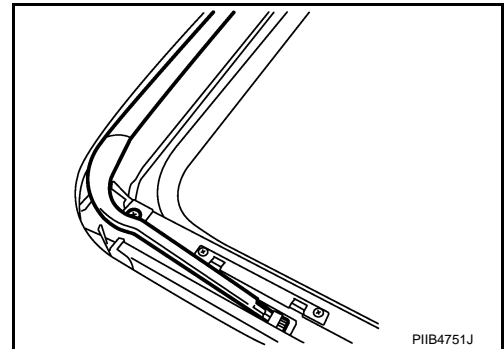

### Installation

Installation is in the reverse order of removal.

## SUNROOF MOTOR ASSEMBLY

### Removal

1. Close the glass lid.
2. Remove headlining. Refer to [EI-40](#).
3. Remove sunroof motor assembly bolts.
4. Disconnect harness connector from sunroof motor assembly, then remove sunroof motor assembly.

### CAUTION:

- When removing the sunroof motor assembly, be sure that the sunroof lid is in the fully closed position.
- Do not operate the removed sunroof motor assembly as a single unit.

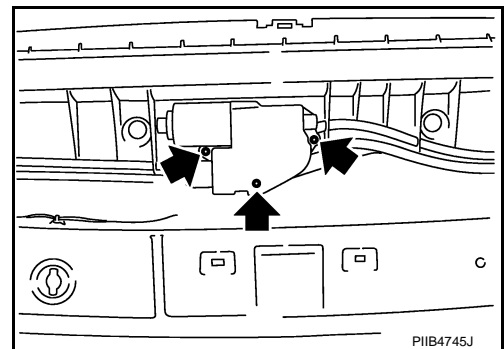

### Installation

### CAUTION:

- Before installing the sunroof motor assembly, be sure the link assembly is in the symmetrical and fully closed position.
  - Align the link notch with the hole of the guide track (fully closed: RH and LH).
1. Place the sunroof motor assembly flat onto the sunroof unit assembly surface.
  2. Laterally move the assembly little by little so that the gear is completely engaged into the wire and there is no gap between the sunroof unit assembly and sunroof motor assembly.

# SUNROOF

## < SERVICE INFORMATION >

3. Install the sunroof motor assembly bolts, then connect the harness connector.
4. After installing, perform the initialization procedure. Refer to [RF-11, "System Description"](#).

### LINK ASSEMBLY

#### Removal

The sunroof link assembly is replaced as part of the sunroof unit assembly.

#### Installation

Installation is in the reverse order of removal.

### Fitting Adjustment

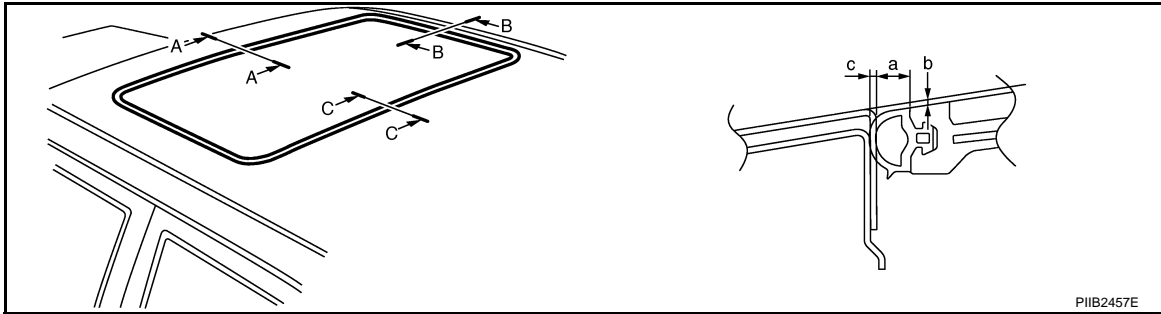

INFOID:000000004407857

Units: mm (in)

	a	b	c
A-A	5.4 (0.21)	-0.8 (-0.03) target specification [-2.3 - 0 (-0.09 - 0) range]	1.4 ± 0.9 (0.06 ± 0.04)
B-B	5.4 (0.21)	-0.8 ± 1.5 (0.03 ± 0.06)	1.4 ± 0.9 (0.06 ± 0.04)
C-C	5.4 (0.21)	-0.8 ± 1.5 (0.03 ± 0.06)	1.4 ± 0.9 (0.06 ± 0.04)

### GAP ADJUSTMENT

1. Tilt up glass lid.
2. Loosen glass lid bolts, then tilt down glass lid.
3. Adjust glass lid from outside of vehicle so it resembles "A-A" "B-B" "C-C" as shown in the figure.
  - For gap adjustment "A-A" "C-C", carefully slide glass lid forward and rearward in vehicle.
  - For gap adjustment "B-B", loosen sunroof unit assembly and shift side to side.

#### NOTE:

To prevent glass lid from moving after adjustment, lightly tighten the bolts.

4. Tighten left front bolt, then right rear bolt to prevent uneven torque. Tighten remaining bolts, being careful to prevent glass lid from moving.
5. Tilt glass lid up and down several times to check that it moves smoothly, and retains the adjustment.

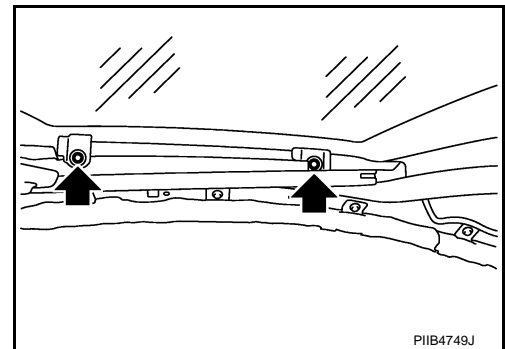

### HEIGHT ADJUSTMENT

1. Tilt up glass lid.
2. Loosen glass lid bolts, then tilt down glass lid.
3. Adjust glass lid from outside of vehicle so it resembles "A-A" "B-B" "C-C" as shown in the figure.
  - For height adjustment, manually raise/lower glass lid assembly until height difference is within specifications.

#### NOTE:

# SUNROOF

## < SERVICE INFORMATION >

- If necessary, shims may be added between sunroof unit assembly and roof panel to increase glass lid height adjustment range.
  - To prevent glass lid from moving after adjustment, lightly tighten the bolts.
4. Tighten left front bolt, then right rear bolt to prevent uneven torque. Tighten remaining bolts, being careful to prevent glass lid from moving.
  5. Tilt glass lid up and down several times to check that it moves smoothly, and retains the adjustment.

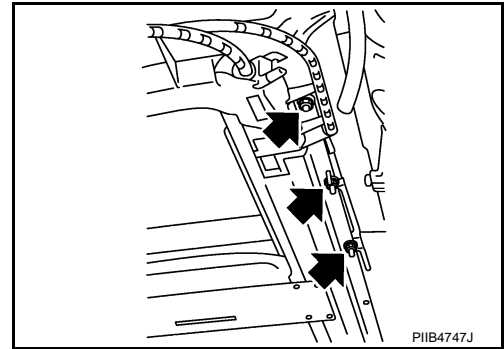

INFOID:000000004407858

## Inspection

### WIND DEFLECTOR

Check that the wind deflector (1) moves freely within the sunroof unit assembly while manually pressing down and releasing. If a malfunction is detected, remove and visually check the deflector for damage, deteriorated components, or foreign objects within mechanism. Check to determine if a sufficient amount of grease has been applied to the pivot areas for non-binding operation, if not add grease as required. If it is damaged, replace it with a new one. If no damage is found, reinstall it properly.

⇐: Vehicle front

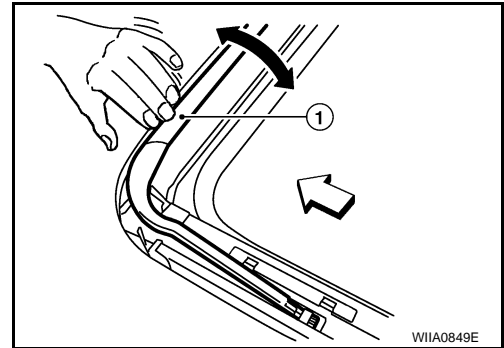

### LINK ASSEMBLY AND WIRE

#### NOTE:

Before replacing a suspect part, make sure it is the source of noise being experienced.

1. Check link to determine if coated film has peeled off to such an extent that substrate is visible. Check also to determine if link is the source of noise. If it is, replace the sunroof unit assembly.
2. Visually check to determine if a sufficient amount of grease has been applied to wire or rail groove of the sunroof unit assembly. If not, add grease as required.
3. Check wire for any damage or deterioration. If any damage is found, replace sunroof unit assembly.

### WEATHERSTRIP

1. Visually check weatherstrip for damage, deterioration, or deformation.
  - Open glass lid assembly enough to inspect front edge of weatherstrip.
  - Tilt up glass lid assembly fully to inspect sides and rear edge of weatherstrip.If any area of the weatherstrip is found to be damaged, replace the glass lid assembly. Refer to [RF-23, "Removal and Installation"](#).
2. Check for leakage around glass lid.
  - Close glass lid fully.
  - Pour water around surface to determine area of concern.
    - For gaps or misalignment, adjust glass lid to specifications. Refer to [RF-27, "Fitting Adjustment"](#).
    - For damaged sealing surfaces, either replace glass lid [RF-23, "Removal and Installation"](#), or repair the panel [BL-207, "Precaution in Repairing High Strength Steel"](#).

### DRAIN HOSES

# SUNROOF

< SERVICE INFORMATION >

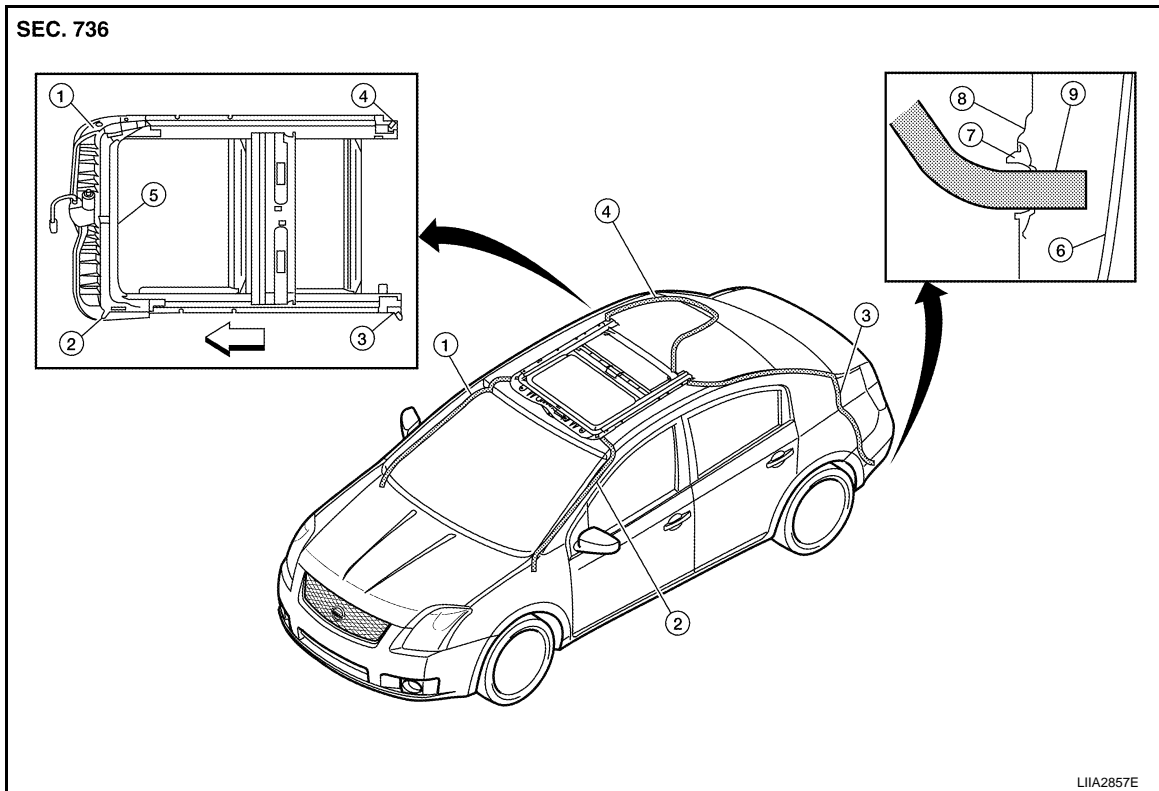

- |                        |                          |                       |
|------------------------|--------------------------|-----------------------|
| 1. Drain hose front RH | 2. Drain hose front LH   | 3. Drain hose rear LH |
| 4. Drain hose rear RH  | 5. Sunroof unit assembly | 6. Fascia             |
| 7. Seal                | 8. Fender                | 9. Drain hose         |
- ← Vehicle front

1. Remove headlining. Refer to [EI-40](#).
  2. Visually check drain hoses for:
    - Proper connection at sunroof unit assembly.
    - Damage, pinch, cracks, deterioration.
    - Proper fastening and routing on body panels.
    - Drain hose rear RH/LH extends  $22.5 \pm 5.0$  mm ( $0.89 \pm 0.20$  in) beyond seal.
  3. Pour water through drain hoses to determine watertight performance.
- If a damaged or leaking portion in any drain hose is found, replace entire drain hose as an assembly.