

SECTION **PS**  
POWER STEERING SYSTEM

A  
B  
C  
D  
E  
F  
PS  
H  
I  
J  
K  
L  
M  
N  
O  
P

CONTENTS

<b>SERVICE INFORMATION</b> .....	2	On-Vehicle Inspection and Service .....	7
<b>PRECAUTIONS</b> .....	2	Removal and Installation .....	8
Precaution for Supplemental Restraint System (SRS) "AIR BAG" and "SEAT BELT PRE-TENSIONER" .....	2	<b>STEERING COLUMN</b> .....	9
Precaution Necessary for Steering Wheel Rotation After Battery Disconnect .....	2	Exploded View .....	9
Precaution for Steering System .....	3	Removal and Installation .....	9
<b>PREPARATION</b> .....	4	<b>POWER STEERING GEAR</b> .....	12
Special Service Tool .....	4	Exploded View .....	12
Commercial Service Tool .....	5	Removal and Installation .....	12
<b>NOISE, VIBRATION AND HARSHNESS (NVH) TROUBLESHOOTING</b> .....	6	Exploded View .....	13
NVH Troubleshooting Chart .....	6	Disassembly and Assembly .....	13
<b>STEERING WHEEL</b> .....	7	<b>SERVICE DATA AND SPECIFICATIONS (SDS)</b> .....	17
		Steering Wheel .....	17
		Steering Angle .....	17
		Steering Column .....	17
		Steering Gear (R24K) .....	18

# PRECAUTIONS

< SERVICE INFORMATION >

## SERVICE INFORMATION

### PRECAUTIONS

#### Precaution for Supplemental Restraint System (SRS) "AIR BAG" and "SEAT BELT PRE-TENSIONER"

INFOID:000000004779245

The Supplemental Restraint System such as "AIR BAG" and "SEAT BELT PRE-TENSIONER", used along with a front seat belt, helps to reduce the risk or severity of injury to the driver and front passenger for certain types of collision. This system includes seat belt switch inputs and dual stage front air bag modules. The SRS system uses the seat belt switches to determine the front air bag deployment, and may only deploy one front air bag, depending on the severity of a collision and whether the front occupants are belted or unbelted. Information necessary to service the system safely is included in the SRS and SB section of this Service Manual.

#### **WARNING:**

- To avoid rendering the SRS inoperative, which could increase the risk of personal injury or death in the event of a collision which would result in air bag inflation, all maintenance must be performed by an authorized NISSAN/INFINITI dealer.
- Improper maintenance, including incorrect removal and installation of the SRS can lead to personal injury caused by unintentional activation of the system. For removal of Spiral Cable and Air Bag Module, see the SRS section.
- Do not use electrical test equipment on any circuit related to the SRS unless instructed to in this Service Manual. SRS wiring harnesses can be identified by yellow and/or orange harnesses or harness connectors.
- When working near the Airbag Diagnosis Sensor Unit or other Airbag System sensors with the Ignition ON or engine running, DO NOT use air or electric power tools or strike near the sensor(s) with a hammer. Heavy vibration could activate the sensor(s) and deploy the air bag(s), possibly causing serious injury.
- When using air or electric power tools or hammers, always switch the Ignition OFF, disconnect the battery, and wait at least 3 minutes before performing any service.

#### Precaution Necessary for Steering Wheel Rotation After Battery Disconnect

INFOID:000000004407450

#### **NOTE:**

- This Procedure is applied only to models with Intelligent Key system and NVIS/IVIS (NISSAN/INFINITI VEHICLE IMMOBILIZER SYSTEM - NATS).
- Remove and install all control units after disconnecting both battery cables with the ignition knob in the "LOCK" position.
- Always use CONSULT-III to perform self-diagnosis as a part of each function inspection after finishing work. If DTC is detected, perform trouble diagnosis according to self-diagnostic results.

For models equipped with the Intelligent Key system and NVIS/IVIS, an electrically controlled steering lock mechanism is adopted on the key cylinder.

For this reason, if the battery is disconnected or if the battery is discharged, the steering wheel will lock and steering wheel rotation will become impossible.

If steering wheel rotation is required when battery power is interrupted, follow the procedure below before starting the repair operation.

#### OPERATION PROCEDURE

1. Connect both battery cables.

#### **NOTE:**

Supply power using jumper cables if battery is discharged.

2. Use the Intelligent Key or mechanical key to turn the ignition switch to the "ACC" position. At this time, the steering lock will be released.
3. Disconnect both battery cables. The steering lock will remain released and the steering wheel can be rotated.
4. Perform the necessary repair operation.
5. When the repair work is completed, return the ignition switch to the "LOCK" position before connecting the battery cables. (At this time, the steering lock mechanism will engage.)
6. Perform a self-diagnosis check of all control units using CONSULT-III.

# PRECAUTIONS

< SERVICE INFORMATION >

## Precaution for Steering System

INFOID:000000004407451

- In case of removing steering gear assembly, make the final tightening with grounded and unloaded vehicle condition, and then check wheel alignment.
- Observe the following precautions when disassembling.
  - Before disassembly, thoroughly clean the outside of the unit.
  - Disassembly should be done in a clean work area. It is important to prevent the internal parts from becoming contaminated by dirt or other foreign matter.
  - For easier and proper assembly, place disassembled parts in order on a parts rack.
  - Use nylon cloth or paper towels to clean the parts; common shop rags can leave lint that might interfere with their operation.
  - Do not reuse non-reusable parts.
  - Before assembling, apply the specified grease to the directed parts.

A

B

C

D

E

F

PS

H

I

J

K

L

M

N

O

P

# PREPARATION

< SERVICE INFORMATION >

## PREPARATION

### Special Service Tool

INFOID:000000004407452

The actual shapes of Kent-Moore tools may differ from those of special tools illustrated here.

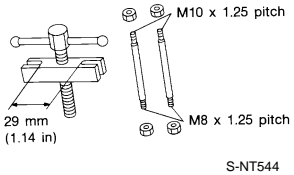
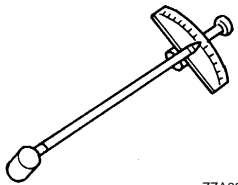
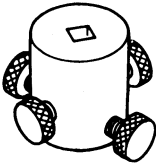
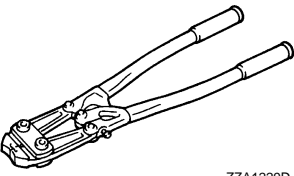
Tool number (Kent-Moore No.) Tool name	Description
ST27180001 (J-25726-A) Steering wheel puller 	Removing steering wheel
ST3127S000 (J-25765-A) Preload gauge 	Inspecting rotating torque for steering column assembly and pinion assembly
KV48103400 ( — ) Preload adapter 	Inspecting of rotating torque for pinion assembly
KV40107300 ( — ) Boot Band crimping tool 	Installing boot bands

# PREPARATION

< SERVICE INFORMATION >

## Commercial Service Tool

INFOID:000000004407453

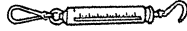
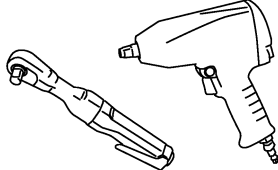
Tool number Tool name	Description
Spring balance  LST025	Inspecting steering wheel turning force and power steering gear linkage
Power tool  PBIC0190E	Loosening bolts and nuts

A

B

C

D

E

F

**PS**

H

I

J

K

L

M

N

O

P

# NOISE, VIBRATION AND HARSHNESS (NVH) TROUBLESHOOTING

< SERVICE INFORMATION >

## NOISE, VIBRATION AND HARSHNESS (NVH) TROUBLESHOOTING

### NVH Troubleshooting Chart

INFOID:000000004407454

Use the chart below to help you find the cause of the symptom. If necessary, repair or replace these parts.

Symptom		Possible cause and SUSPECTED PARTS														Reference page		
		Inner/Outer socket ball joint swinging torque	Inner/Outer socket ball joint end play	Steering wheel play	Steering gear pinion rotating torque	Improper steering wheel	Improper installation or looseness of tilt lock lever	Mounting looseness	Steering column deformation or damage	Improper installation or looseness of steering column	Steering linkage looseness	AXLE	SUSPENSION	TIRES	ROAD WHEEL		DRIVE SHAFT	BRAKES
Noise	Noise	x	x	x	x					x								<a href="#">PS-13</a>
	Shake					x	x	x				x	x	x	x	x		<a href="#">PS-13</a>
	Vibration					x	x	x	x	x		x	x	x		x		<a href="#">PS-7</a>
	Shimmy					x	x	x			x	x	x	x	x			<a href="#">PS-7</a>
	Shudder							x			x	x	x	x	x			<a href="#">PS-9</a>
																		<a href="#">PS-12</a>
																		<a href="#">PS-9</a>
																		<a href="#">PS-9, PS-9</a>
																		<a href="#">PS-13</a>
																		<a href="#">FAX-5, "NVH Troubleshooting Chart"</a>
																		<a href="#">FSU-6, "NVH Troubleshooting Chart"</a>
																		<a href="#">WT-4, "NVH Troubleshooting Chart"</a>
																		<a href="#">WT-4, "NVH Troubleshooting Chart"</a>
																		<a href="#">FAX-5, "NVH Troubleshooting Chart"</a>
																		<a href="#">BR-4, "NVH Troubleshooting Chart"</a>

x: Applicable

# STEERING WHEEL

< SERVICE INFORMATION >

## STEERING WHEEL

### On-Vehicle Inspection and Service

INFOID:000000004407455

#### CHECKING CONDITION OF INSTALLATION

- Check installation conditions of steering gear assembly, front suspension assembly, axle and steering column assembly.
- Check if movement exists when steering wheel is moved up and down, to the left and right and to the axial direction.

**Steering wheel axial end play** Refer to [PS-17, "Steering Wheel"](#)

- Check steering gear assembly mounting bolts and nuts for looseness. Refer to [PS-12, "Removal and Installation"](#).

#### CHECKING STEERING WHEEL PLAY

1. Turn steering wheel so that front wheels come to the straight-ahead position. Start engine and lightly turn steering wheel to the left and right until front wheels start to move. Measure steering wheel movement on the outer circumference.

**Steering wheel play** Refer to [PS-17, "Steering Wheel"](#)

2. When the measurement value is outside the standard value, check backlash for each joint of steering column assembly and installation condition of steering gear assembly.

#### CHECKING NEUTRAL POSITION STEERING WHEEL

##### NOTE:

Perform neutral position inspection after wheel alignment.

1. Make sure that steering gear assembly, steering column assembly and steering wheel are installed in the correct position.
2. Set vehicle to the straight-ahead position and confirm steering wheel is in the neutral position.
  - Loosen outer socket lock nut and turn inner socket to left and right equally to make fine adjustments if steering wheel is not in the neutral position. Refer to [PS-13, "Disassembly and Assembly"](#).

##### CAUTION:

**Check the wheel alignment after adjusting the inner socket. Refer to [FSU-7, "Wheel Alignment Inspection"](#)**

#### CHECKING STEERING WHEEL TURNING FORCE

1. Park vehicle on a level and dry surface, set parking brake.
2. Start engine.
3. Check steering wheel turning force when steering wheel has been turned 360° from neutral position using suitable tool as shown.

**Steering wheel turning force** Refer to [PS-17, "Steering Wheel"](#)

4. If steering wheel turning force is out of the specification, remove intermediate shaft and steering knuckle, and then measure the rotating torque of the pinion assembly. Refer to [PS-13, "Disassembly and Assembly"](#).

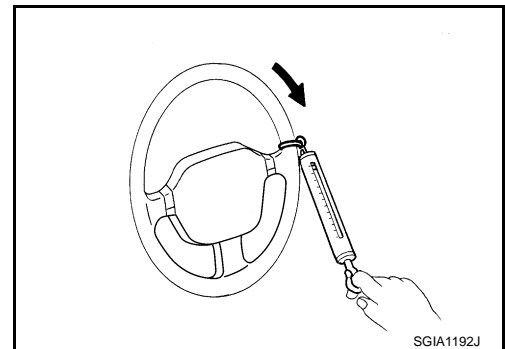

#### CHECKING FRONT WHEEL TURNING ANGLE

Check the maximum inside and outside front wheel turning angle for right and left with the turning radius gauges as per the following procedure.

1. Check toe-in.

##### NOTE:

Perform front wheel turning angle after the toe-in check.

# STEERING WHEEL

## < SERVICE INFORMATION >

- Place front wheels on turning radius gauges and rear wheels on stands.

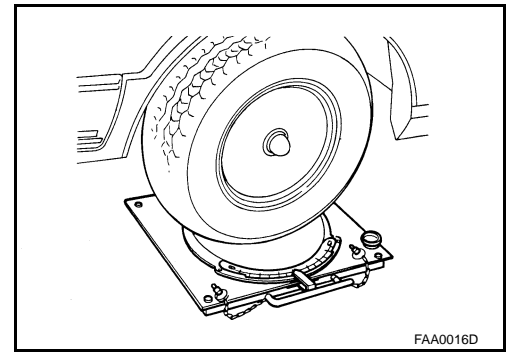

- With the engine at idle, turn steering wheel from full left stop to full right stop and measure the turning angles. Refer to [PS-17, "Steering Angle"](#).

- Measure rack stroke if angles are outside the specified value.

**Rack stroke L** Refer to [PS-17, "Steering Column"](#)

- Disassemble steering gear assembly to check the cause that rack stroke is outside of the standard.
- Steering angles are not adjustable. Check steering gear assembly, steering column assembly and front suspension components for wear or damage if any of the turning angles are different from the specified value. Replace any of them, if any non-standard condition exists.

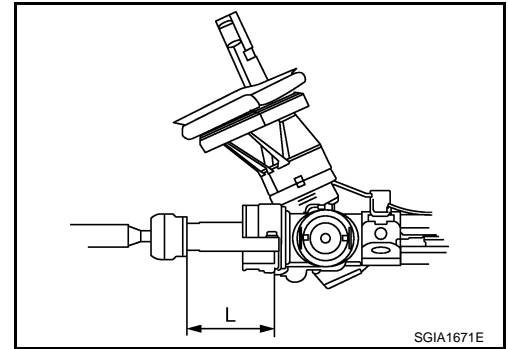

## Removal and Installation

INFOID:000000004407456

### REMOVAL

#### NOTE:

When reconnecting spiral cable, fix cable with a tape so that fixing case and rotating part keep aligned. This will omit neutral position alignment procedure during spiral cable installation.

- Set vehicle to the straight-ahead position.
- Remove driver air bag module. Refer to [SRS-31](#).
- Remove steering wheel lock nut after steering is locked.
- Remove steering wheel using Tool.

**Tool number A: ST27180001 (J-25726-A)**

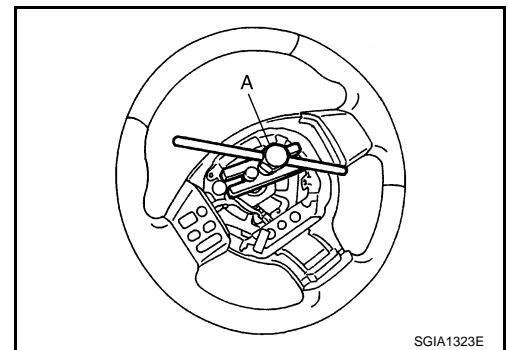

### INSTALLATION

Installation is the reverse order of removal. For tightening torque, refer to [PS-9, "Removal and Installation"](#).

#### NOTE:

Check the spiral cable neutral position after replacing or rotating spiral cable. Refer to [SRS-33, "Removal and Installation"](#).

#### CAUTION:

**Do not twist spiral cable freely on excessively after it becomes tight (doing so may cause the cable to be turn off).**



# STEERING COLUMN

< SERVICE INFORMATION >

## STEERING COLUMN

### Exploded View

INFOID:000000004752204

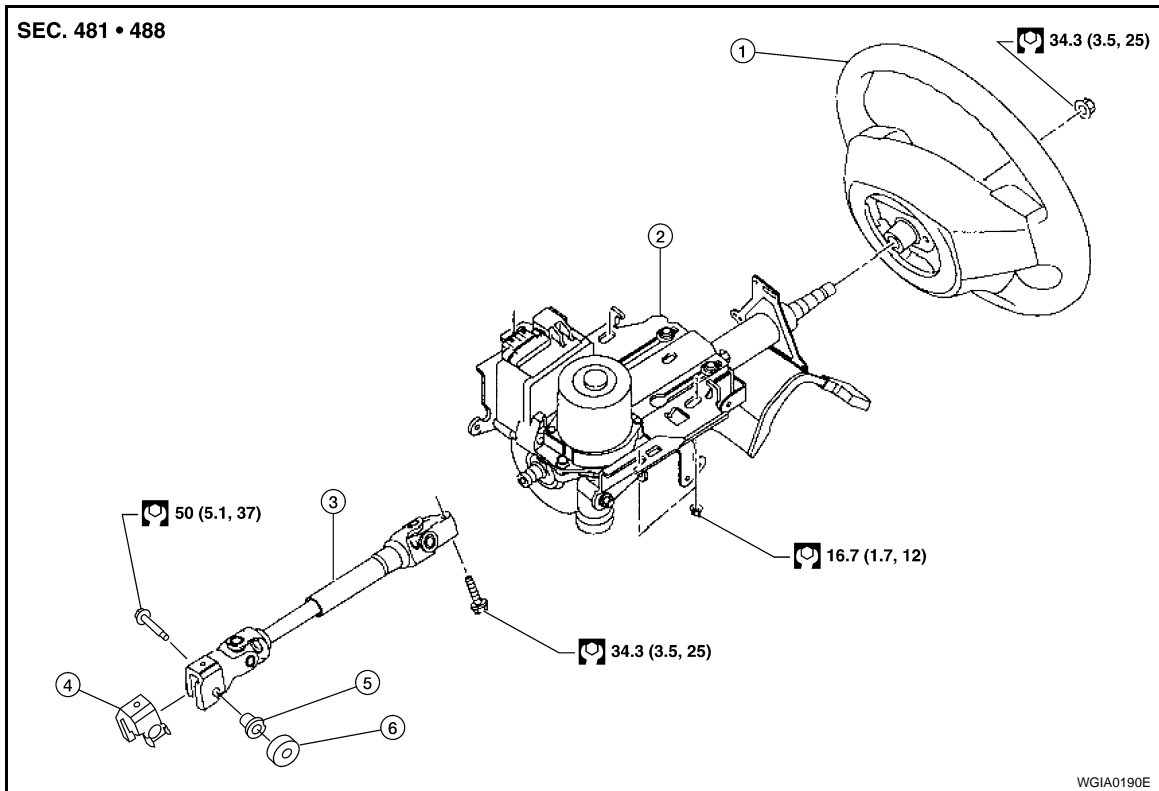

- |                   |                             |                       |
|-------------------|-----------------------------|-----------------------|
| 1. Steering wheel | 2. Steering column assembly | 3. Intermediate shaft |
| 4. Holder         | 5. Cam nut                  | 6. Cover              |

### Removal and Installation

INFOID:000000004407457

#### CAUTION:

- Any time the ignition switch has been removed or installed, the keys must be re-registered in the BCM. Refer to CONSULT-III operation manual IVIS/NVIS.
- Steering column must be kept at maximum tilt up position during removal and installation. Do not operate tilt mechanism while steering column is out of the vehicle.
- Put matching mark on intermediate shaft and steering column assembly before removing intermediate shaft.
- When steering wheel is turned repeatedly with the vehicle stopped, care must be taken because EPS motor and EPS control unit may get too hot.
- Steering column assembly is heavy. Care must be taken when removing steering column assembly from vehicle.
- Do not put steering column assembly near the things that generate excessive magnetic force.
- Steering column assembly cannot be disassembled.

#### REMOVAL

1. Set vehicle to the straight ahead-position.
2. Remove driver air bag module. Refer to [SRS-31](#).
3. Remove steering wheel. Refer to [PS-8, "Removal and Installation"](#).
4. Remove steering column cover (upper and lower). Refer to [IP-11, "Component Parts"](#).
5. Remove combination switch and spiral cable. Refer to [SRS-33](#).
6. Remove instrument lower finisher. Refer to [IP-11, "Component Parts"](#).
7. Disconnect each switch connectors installed to steering column assembly, and then disconnect harness from steering column assembly.

# STEERING COLUMN

## < SERVICE INFORMATION >

8. Remove bolt of intermediate shaft (upper side), and then remove intermediate shaft from steering column assembly.
9. Remove steering column assembly nuts, then remove steering column assembly from vehicle.
10. Remove intermediate shaft (lower side) from steering gear assembly with the following procedure.

### CAUTION:

- Never deform or bend the holder.
- Never replace the intermediate shaft if the holder is deformed or bent.

- a. Insert a suitable tool between the cover and the holder. Then push the cover down in the direction shown and remove the cover.
- b. Remove bolt.

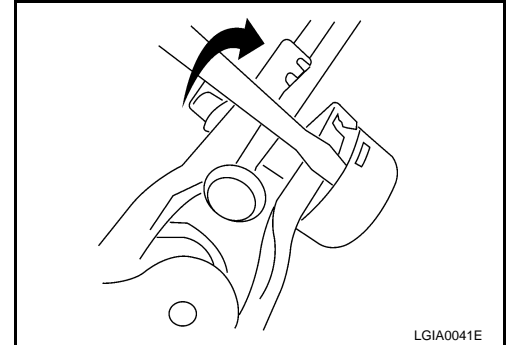

- c. Rotate the cam nut to direction (A). Align the cam nut V-shaped groove (1) with the holder (2) V-guide. Fit the cam nut to the holder V-guide, then remove the cam nut from the holder.

### CAUTION:

- Rotate the cam nut if the nut becomes misaligned as shown. Align the cam nut V-shaped groove with the holder V-guide.
- There are two different grooves, but only one that fits the holder V-guide.

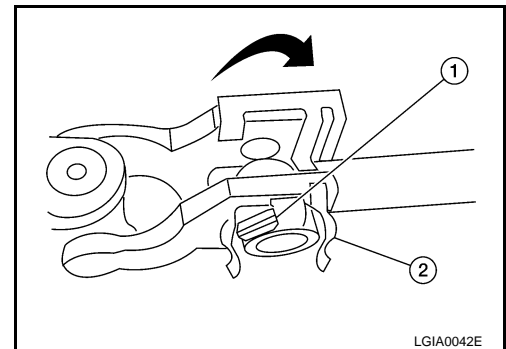

- d. Remove the intermediate shaft by removing the holder pawl from the pinion shaft groove (A) and slide out the intermediate shaft using a suitable tool.

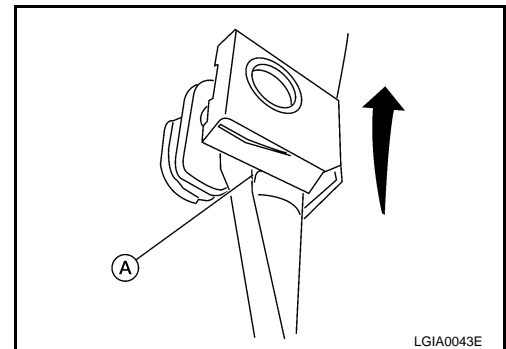

## INSPECTION AFTER REMOVAL

- Check each part of steering column assembly and intermediate shaft for damage or other malfunctions. Replace if there are.
- Measure the length (L) as shown, if vehicle has been involved in a minor collision. Replace steering column assembly if outside the standard. Refer to [PS-17, "Steering Column"](#).
- Check tilt mechanism for damage or other malfunctions. Replace steering column assembly as necessary.
- Measure steering column assembly rotating torque using Tool. Replace steering column assembly if outside the standard. Refer to [PS-17, "Steering Column"](#).

Tool number : ST3127S000 (J-25765-A)

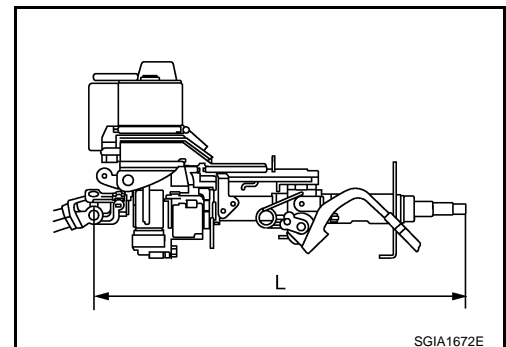

## INSTALLATION

# STEERING COLUMN

## < SERVICE INFORMATION >

Installation is in the reverse order of removal. For tightening torque, refer to [PS-9. "Exploded View"](#).

- Align the cam nut V-shaped groove with the holder V-guide (1).  
Install the cam nut to the holder guide.

**CAUTION:**

- **Make sure cam nut is installed correctly to keep it from loosening.**
- **Replace intermediate shaft assembly if cam nut does not fit to the holder.**
- **Do not install the cam nut on the incorrect side.**

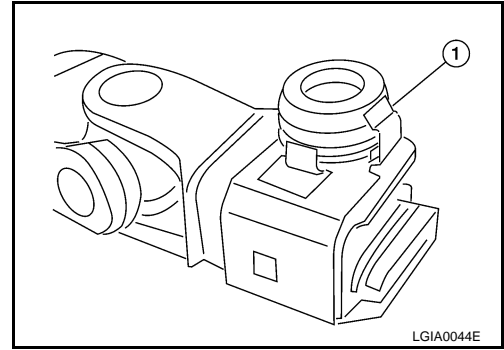

- Install the intermediate shaft by pushing the holder pawl to the pinion shaft and sliding the intermediate shaft to (A).

**CAUTION:**

- **Replace the intermediate shaft assembly if the pawl is deformed.**

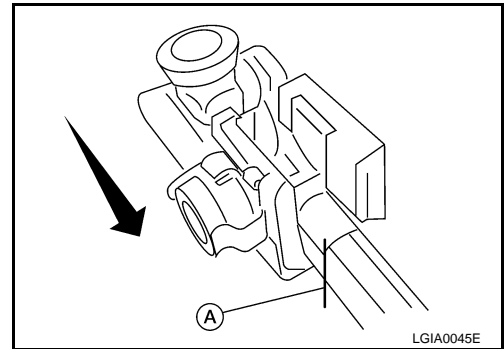

- Install a new bolt and tighten to specification. Refer to [PS-9. "Exploded View"](#).

**CAUTION:**

- **Make sure cam nut contacts pinion shaft correctly.**
- **Make sure the holder is not deformed or interfering with the cam nut.**
- Install the cover (1) to the holder (2).

**CAUTION:**

- **Align the cover groove with the holder guide.**
- **Make sure cover is installed correctly.**

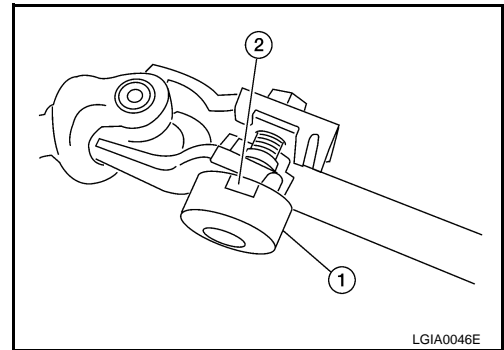

## INSPECTION AFTER INSTALLATION

- Rotate steering wheel to check for decentered condition, binding, noise or excessive steering effort.
- Check tilt mechanism operating range. Refer to [PS-17. "Steering Column"](#).
- After installing steering column assembly, perform self-diagnosis of EPS system with CONSULT-III to ensure correct operation. Refer to [BRC-18. "CONSULT-III Function \(ABS\)"](#).

A  
B  
C  
D  
E  
F  
PS  
H  
I  
J  
K  
L  
M  
N  
O  
P

# POWER STEERING GEAR

< SERVICE INFORMATION >

## POWER STEERING GEAR

Exploded View

INFOID:000000004752205

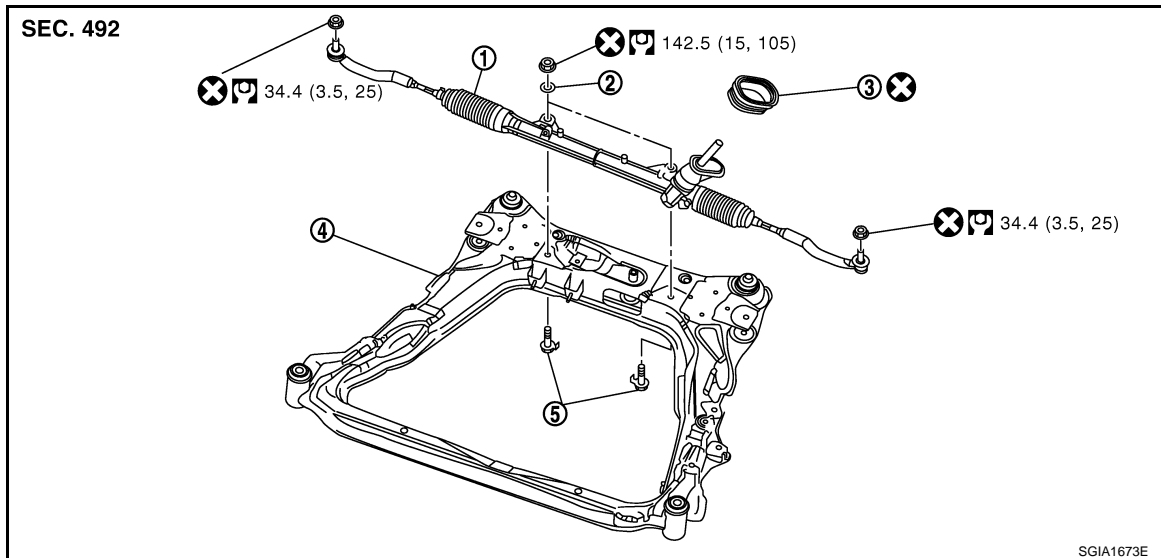

- |                            |                       |                    |
|----------------------------|-----------------------|--------------------|
| 1. Steering gear assembly  | 2. Washer             | 3. Lower dash seal |
| 4. Front suspension member | 5. Steering gear bolt |                    |

## Removal and Installation

INFOID:000000004407458

### CAUTION:

Spiral cable may be cut if steering wheel turns while separating steering column assembly and steering gear assembly. Be sure to secure steering wheel using string to avoid turning.

### REMOVAL

1. Set vehicle to the straight-ahead position.
2. Remove bolt of intermediate shaft (lower side). Refer to [PS-9, "Removal and Installation"](#).
3. Raise vehicle.
4. Remove tires from vehicle with a power tool.
5. Loosen steering outer socket (1) nut.

6. Remove steering outer socket (1) from steering knuckle (2) so as not to damage ball joint boot (3) using the ball joint remover (suitable tool).

### CAUTION:

Temporarily tighten the nut to prevent damage to threads and to prevent the ball joint remover from suddenly coming off.

7. Remove front suspension member. Refer to [FSU-11, "Removal and Installation"](#).
8. Remove bolts and nuts of steering gear assembly.

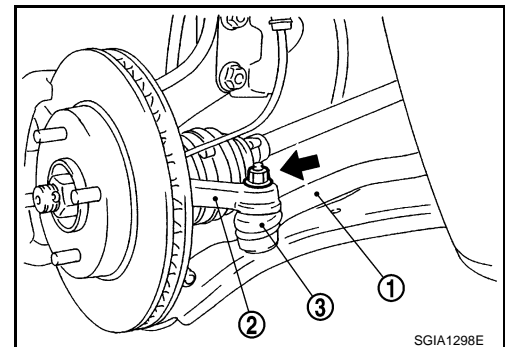

### INSTALLATION

Installation is in the reverse order of removal.

- Clean mating surface on the body side of fire wall seal when installing steering gear assembly.
- Perform final tightening of nuts and bolts on each part under unladen conditions with tires on level ground when removing steering gear assembly. Check wheel alignment. Refer to [FSU-7, "Wheel Alignment Inspection"](#).

### INSPECTION AFTER INSTALLATION

Rotate steering wheel to check for decentered condition, binding, noise or excessive steering effort.

# POWER STEERING GEAR

< SERVICE INFORMATION >

## Exploded View

INFOID:000000004752206

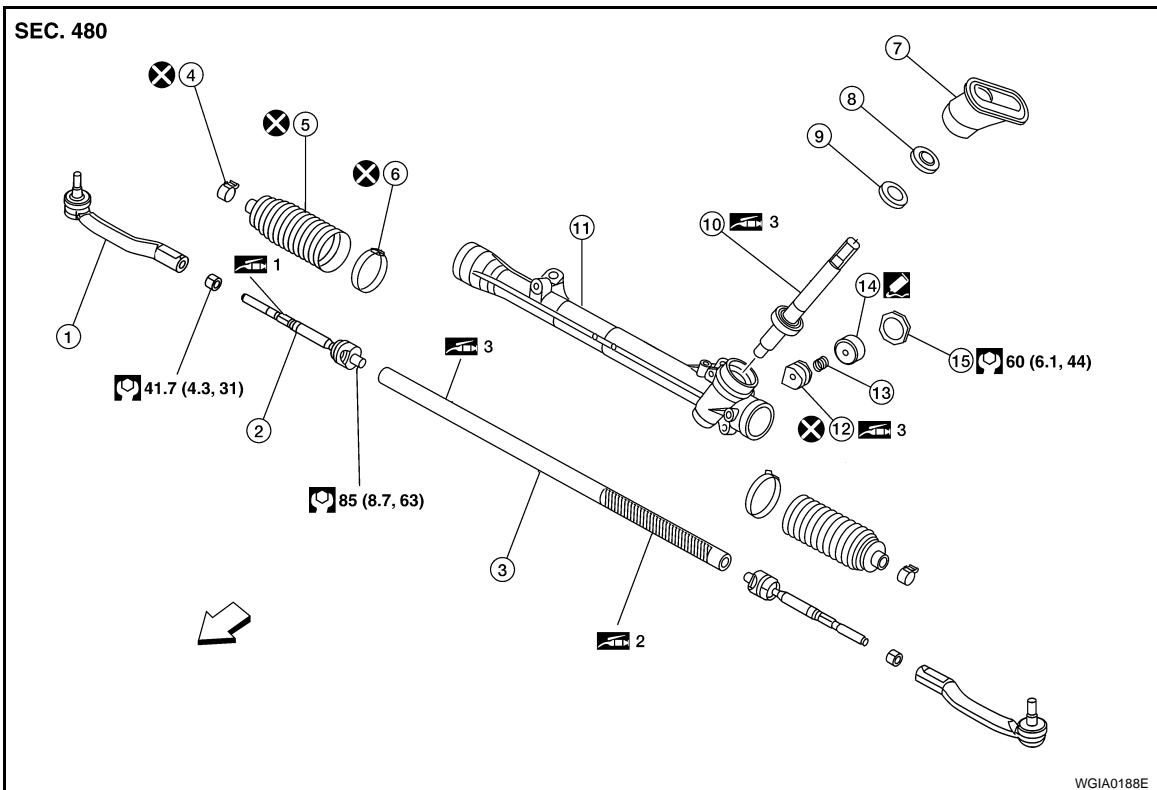

- |                                |                           |                                |
|--------------------------------|---------------------------|--------------------------------|
| 1. Outer socket                | 2. Inner socket           | 3. Rack assembly               |
| 4. Boot clamp (small diameter) | 5. Boot                   | 6. Boot clamp (large diameter) |
| 7. Joint cover                 | 8. Pinion seal            | 9. Snap ring                   |
| 10. Pinion assembly            | 11. Gear housing assembly | 12. Retainer                   |
| 13. Spring                     | 14. Adjusting screw       | 15. Lock nut                   |

← : Front

Apply Genuine Thread Locking Sealant, Three Bound 1141 or equivalent.

1 Apply Genuine Lithium Soap, Idemitsu Autorex A or equivalent.

2 Apply Genuine Lithium Soap, Wanlouver MO No.2 (manufactured by Kyoudouyushi) or equivalent.

3 Apply Genuine Lithium Soap, Multemp AC-P (manufactured by Kyoudouyushi) or equivalent.

## Disassembly and Assembly

INFOID:000000004407459

### CAUTION:

**Clean steering gear assembly with kerosene before disassembling.**

### DISASSEMBLY

- Loosen outer socket lock nut, and then remove outer socket from inner socket.
- Remove boot clamp, and then remove boot from inner socket.

### CAUTION:

**Do not damage inner socket and gear housing assembly when removing boot. Inner socket and gear housing assembly must be replaced if inner socket and gear housing assembly are damaged because it may allow foreign material to enter.**

- Remove inner socket from rack assembly while holding the flat portion of the rack next to the inner socket using a suitable tool.

# POWER STEERING GEAR

## < SERVICE INFORMATION >

4. Measure adjusting screw height "H", and loosen lock nut (2).
5. Remove adjusting screw (1), retainer (3) and spring (4) from gear housing assembly (5).

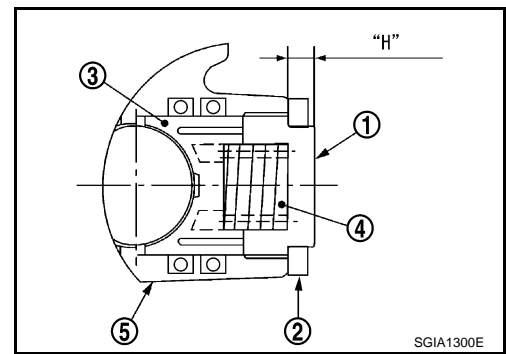

## INSPECTION AFTER DISASSEMBLY

### Joint Cover

Check joint cover protrusion for damage. Replace if there are.

### Rack and Pinion Assembly

- Check pinion assembly for damage or wear. Replace as necessary.
- Rotate pinion assembly and check for torque variation or rattle. Replace steering gear as necessary.

### Gear Housing Assembly

Check gear housing assembly for damage or scratches. Replace steering gear as necessary.

### Outer Socket and Inner Socket

1. Check ball joint swinging torque.
  - Hook a spring balance at the points P1, P2 as shown and pull the spring balance. Make sure that the spring balance reads the specified value when ball stud and inner socket start to move. Replace inner socket (1) and outer socket (2) if they are outside the standard. Refer to [PS-18. "Steering Gear \(R24K\)"](#).
2. Ball joint axial end play
  - Apply an axial load of 490 N (50 kg-f, 111 lb-f) to ball stud. Measure amount of stud movement using a dial gauge, and then make sure that the value is within the specified range. Replace outer socket and inner socket if the measured value is outside the standard. Refer to [PS-18. "Steering Gear \(R24K\)"](#).

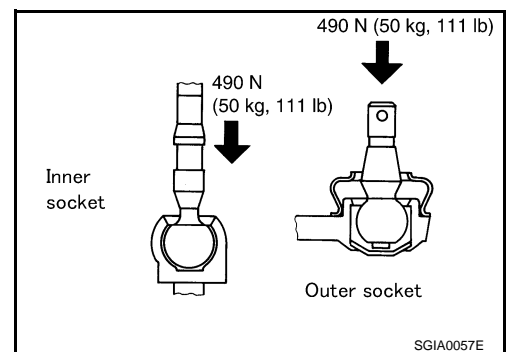
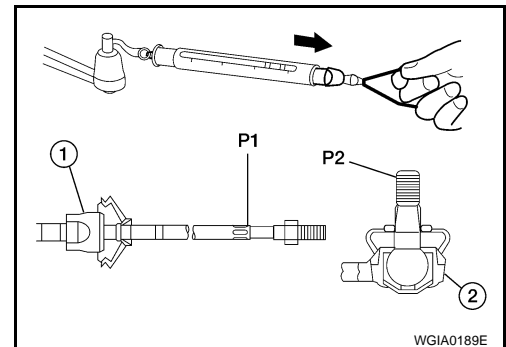

## ASSEMBLY

1. Apply recommended grease to the rack bush in the gear housing assembly.
2. Apply recommended grease to teeth part and back of rack assembly.
3. Install inner socket to rack assembly. Torque to specified value while holding the flat portion of the rack next to the inner socket using a suitable tool.
4. Apply recommended grease to inner socket. For application points, refer to ["PS-13. "Exploded View"](#).
5. Decide on the neutral position for the rack assembly. Refer to [PS-18. "Steering Gear \(R24K\)"](#).

# POWER STEERING GEAR

## < SERVICE INFORMATION >

6. Apply recommended grease to around retainer (3), then install retainer (3), spring (4) and adjusting screw (1) to gear housing assembly (5).
7. Apply recommended thread locking sealant to the thread (2 turns thread), and then screw in the adjusting screw (1) until it reaches height "H" from gear housing assembly (5) measured before disassembling.
8. Tighten lock nut to (2) the specified torque securing it to prevent adjusting screw (1) from freewheeling condition.
9. Move rack assembly 10 strokes throughout the full stroke so that the parts can fit with each other.

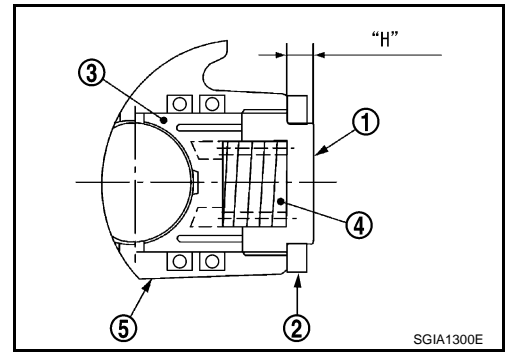

10. Using tools measure rotating torque of pinion assembly. If the measurement is outside of the specified range, readjust pinion rotating torque. If the measurement is outside of the specified range for readjust, replace steering gear assembly. Refer to [PS-18. "Steering Gear \(R24K\)"](#).

11. Set dial gauge to the back of rack assembly on the pinion assembly side around the center of stroke. Measure displacement of rack under torsional torque of  $\pm 7.8$  N·m (0.80 kg·m, 69 in·lb), and then check if it is within the standard value. If the measurement is outside the standard value, adjust it again. After the readjustment, if measurement is still outside the standard value, replace steering gear assembly. Refer to [PS-18. "Steering Gear \(R24K\)"](#).

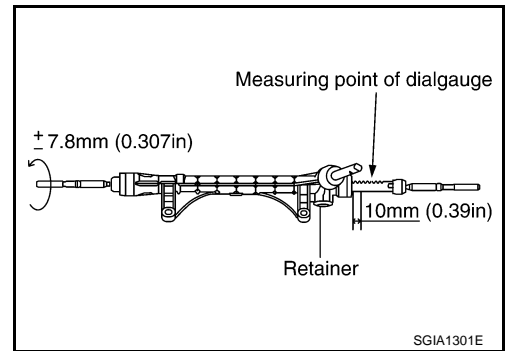

12. Install boot to gear housing assembly and inner socket.

13. Install boot clamp (1) to boot using Tool.

**NOTE:**

Install large diameter side boot clamp (1) securely to boot groove, and crimp it so as to have clearance of 3 mm (0.12 in) or less as shown.

**Tool number** : KV40107300 ( — )

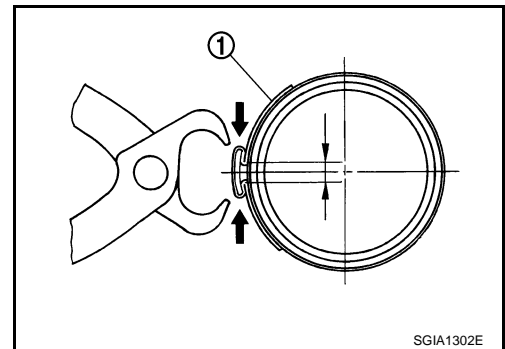

14. Install joint cover (1) to gear housing assembly (2).

**CAUTION:**

Install joint cover so that the protrusion for locating is securely set to gear housing groove.

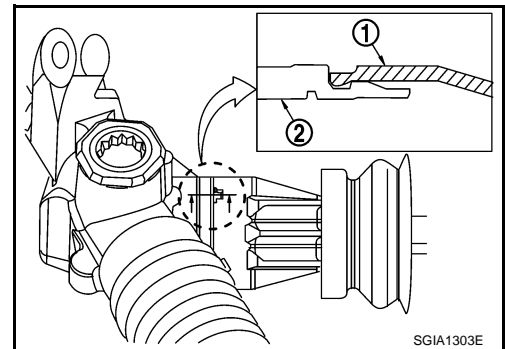

## POWER STEERING GEAR

### < SERVICE INFORMATION >

15. Adjust inner socket to standard length "L", and then tighten lock nut to the specified torque. Refer to [PS-13, "Exploded View"](#). Check length of inner socket "L" again after tightening lock nut. Make sure that the length is the standard. Refer to [PS-18, "Steering Gear \(R24K\)"](#).

**CAUTION:**

Adjust toe-in. Refer to [FSU-7, "Wheel Alignment Inspection"](#). Length achieved after toe-in adjustment is not necessarily the above value.

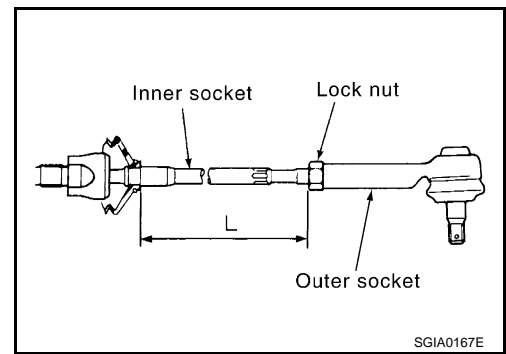



# SERVICE DATA AND SPECIFICATIONS (SDS)

< SERVICE INFORMATION >

## SERVICE DATA AND SPECIFICATIONS (SDS)

### Steering Wheel

INFOID:000000004407460

Steering wheel axial end play	0 mm (0 in)
Steering wheel play	0 – 35 mm (0 – 1.38 in)
Steering wheel turning force	Less than 36 N (3.7 kg-f, 8.2 lb-f)

### Steering Angle

INFOID:000000004407461

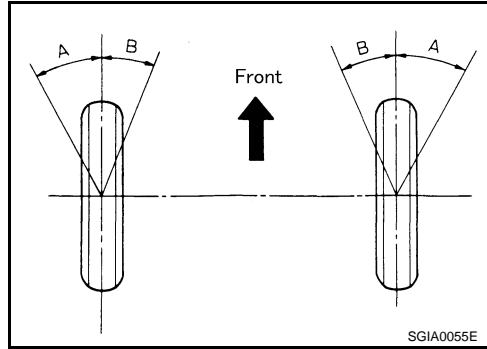

Application		Except SE-R models	SER models
Inner wheel (Angle: A) Degree minute (Decimal degree)	Minimum	36°00' (36.0°)	33°00' (33.0°)
	Nominal	39°00' (39.0°)	36°00' (36.0°)
	Maximum	40°00' (40.0°)	37°00' (37.0°)
Outer wheel (Angle: B) Degree minute (Decimal degree)		33°00' (33.0°)	30°00' (30.0°)

### Steering Column

INFOID:000000004407462

Steering Column Rotating Torque	0 - 2.1 N·m (0 - 0.21 kg-m, 0 - 18 in-lb)	
Steering column length L	Minimum	478.3 mm (18.83 in)
	Nominal	480.3 mm (18.91 in)
	Maximum	482.3 mm (18.99 in)

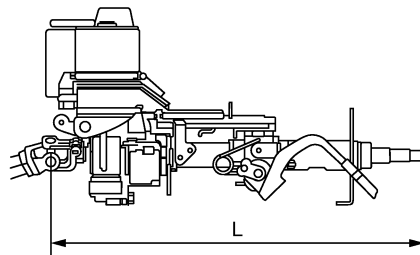

SGIA1672E

### TILT MECHANISM OPERATING RANGE

# SERVICE DATA AND SPECIFICATIONS (SDS)

## < SERVICE INFORMATION >

Tilt mechanism operating range L (above center line)	14.8 mm (0.58 in)
Tilt mechanism operating range L (below center line)	20 mm (0.79 in)

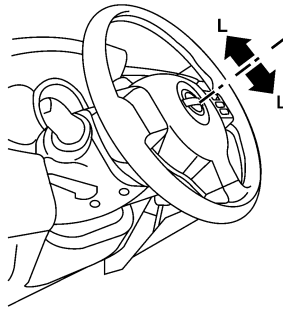

LGIA0040E

## Steering Gear (R24K)

INFOID:000000004407463

### BALL JOINT SWINGING TORQUE

Inner socket ball joint	Measurement on spring balance (Measuring point: P1)	55.7 N (5.7 kg-f, 13 lb-f) or less
Outer socket ball stud	Measurement on spring balance (Measuring point: Top end of the ball stud threads P2)	6.0 – 58 N (0.61 – 5.91 kg-f, 1.35 – 13.03 lb-f)

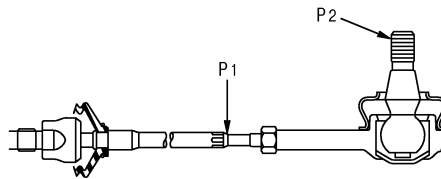

SGIA1553J

### BALL JOINT AXIAL END PLAY

Outer socket ball stud	0.5 mm (0.020 in) or less
Inner socket ball joint	0.2 mm (0.008 in) or less

### INNER SOCKET INSTALLATION LENGTH

# SERVICE DATA AND SPECIFICATIONS (SDS)

## < SERVICE INFORMATION >

Inner socket installation length L	112.9 mm (4.445 in)
------------------------------------	---------------------

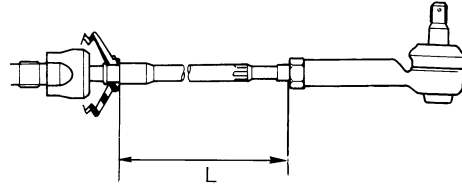

SGIA1512E

## PINION ROTATING TORQUE

Average A [Around neutral position (within $\pm 100^\circ$ )]	0.6 – 1.1 N·m (0.07 – 0.11 kg·m, 6 – 9 in·lb)
Maximum value C	1.49 N·m (0.15 kg·m, 13 in·lb)

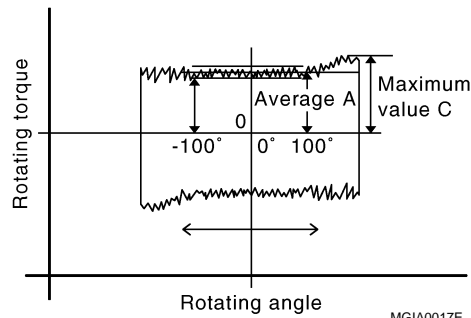

MGIA0017E

## RACK STROKE

Model	Except SE-R models	SE-R models
Rack neutral position, dimension L (rack stroke)	72.0 mm (2.835 in)	67.7 mm (2.665 in)

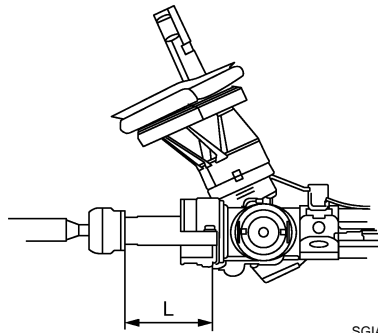

SGIA1671E