

SECTION **LT**
LIGHTING SYSTEM

A
B
C
D
E
F
G
H
I
J
LT
L
M
N
O
P

CONTENTS

SERVICE INFORMATION	3	CAN Communication System Description	27
PRECAUTIONS	3	Schematic	28
Precaution for Supplemental Restraint System (SRS) "AIR BAG" and "SEAT BELT PRE-TENSIONER"	3	Wiring Diagram - DTRL -	29
HEADLAMP (FOR USA)	4	Terminal and Reference Value for BCM	32
Component Parts and Harness Connector Location	4	Terminal and Reference Value for IPDM E/R	32
System Description	4	How to Perform Trouble Diagnosis	33
CAN COMMUNICATION SYSTEM DESCRIPTION	5	Preliminary Check	33
Schematic	6	CONSULT-III Function (BCM)	33
Wiring Diagram	7	CONSULT-III Function (IPDM E/R)	33
Terminal and Reference Value for BCM	10	Daytime Light Control Does Not Operate Properly (High Beam Headlamps Operate Properly)	33
Terminal and Reference Value for IPDM E/R	10	Aiming Adjustment	34
How to Perform Trouble Diagnosis	11	Bulb Replacement	34
Preliminary Check	11	Removal and Installation	34
CONSULT-III Function (BCM)	11	Disassembly and Assembly	35
CONSULT-III Function (IPDM E/R)	12	FRONT FOG LAMP	36
Headlamp High Beam Does Not Illuminate (Both Sides)	13	Component Parts and Harness Connector Location	36
Headlamp High Beam Does Not Illuminate (One Side)	15	System Description	36
High Beam Indicator Lamp Does Not Illuminate	16	CAN Communication System Description	37
Headlamp Low Beam Does Not Illuminate (Both Sides)	16	Wiring Diagram - F/FOG -	38
Headlamp Low Beam Does Not Illuminate (One Side)	19	Terminal and Reference Value for BCM	39
Headlamps Do Not Turn OFF	20	Terminal and Reference Value for IPDM E/R	39
Aiming Adjustment	21	How to Proceed with Trouble Diagnosis	40
Bulb Replacement	22	Preliminary Check	40
Removal and Installation	23	CONSULT-III Function (BCM)	40
Disassembly and Assembly	24	CONSULT-III Function (IPDM E/R)	40
HEADLAMP (FOR CANADA) - DAYTIME LIGHT SYSTEM -	25	Front Fog lamps Do Not Illuminate (Both Sides)	40
Component Parts and Harness Connector Location	25	Front Fog Lamp Does Not Illuminate (One Side)	42
System Description	25	Aiming Adjustment	43
		Bulb Replacement	43
		Removal and Installation, All Except SE-R	44
		Removal and Installation, SE-R	44
		TURN SIGNAL AND HAZARD WARNING LAMPS	45
		Component Parts and Harness Connector Location	45
		System Description	45
		CAN Communication System Description	47

Schematic	48	Schematic	69
Wiring Diagram - TURN -	49	Wiring Diagram - TAIL/L -	70
Terminal and Reference Value for BCM	52	Terminal and Reference Value for BCM	72
How to Proceed with Trouble Diagnosis	52	Terminal and Reference Value for IPDM E/R	72
Preliminary Check	53	How to Proceed with Trouble Diagnosis	73
CONSULT-III Function (BCM)	53	Preliminary Check	73
Turn Signals Do Not Operate	53	CONSULT-III Function (BCM)	73
Front Turn Signal Lamp Does Not Operate	53	CONSULT-III Function (IPDM E/R)	73
Rear Turn Signal Lamp Does Not Operate	54	Parking, License Plate and Tail Lamps Do Not Il- luminare	73
Hazard Warning Lamp Does Not Operate But Turn Signal Lamp Operates	55	Front Parking Lamps Do Not Illuminate (License Plate and Tail Lamps Operate Normally)	74
Turn Signal Indicator Lamp Does Not Operate	56	License Plate and Tail Lamps Do Not Illuminate (Front Parking Lamps Operate Normally)	75
Bulb Replacement for Front Turn Signal Lamp	56	Parking, License Plate and Tail Lamps Do Not Turn OFF (After Approx. 10 Minutes)	77
Bulb Replacement for Rear Turn Signal Lamp	56	Bulb Replacement	77
Removal and Installation of Front Turn Signal Lamp	56	Removal and Installation	77
Removal and Installation of Rear Turn Signal Lamp	56		
LIGHTING AND TURN SIGNAL SWITCH	57	REAR COMBINATION LAMP	79
Removal and Installation	57	Component	79
HAZARD SWITCH	58	Bulb Replacement	79
Removal and Installation	58	Removal and Installation	80
COMBINATION SWITCH	59	Disassembly and Assembly	80
Wiring Diagram - COMBSW -	59	INTERIOR LAMP	81
Combination Switch Reading Function	59	Map Lamp	81
Terminal and Reference Value for BCM	60	Trunk Room Lamp	81
CONSULT-III Function (BCM)	60	INTERIOR ROOM LAMP	83
Combination Switch Inspection	60	Component Parts and Harness Connector Loca- tion	83
Removal and Installation	62	System Description	83
STOP LAMP	63	Schematic	87
Wiring Diagram - STOP/L -	63	Wiring Diagram - INT/L -	88
Bulb Replacement for High-Mounted Stop Lamp ...	63	Terminal and Reference Value for BCM	91
Bulb Replacement for Rear Combination Lamp for Stop Lamp	64	How to Proceed with Trouble Diagnosis	91
Removal and Installation of High-Mounted Stop Lamp, All Except SE-R	64	Preliminary Check	92
Removal and Installation of High-Mounted Stop Lamp, SE-R	64	CONSULT-III Function (BCM)	92
Removal and Installation of Rear Combination Lamp for Stop Lamp	64	Interior Room Lamp Control Does Not Operate	93
BACK-UP LAMP	65	Bulb Replacement	94
Wiring Diagram - BACK/L -	65	Removal and Installation	94
Bulb Replacement	65	ILLUMINATION	96
Removal and Installation	66	System Description	96
PARKING, LICENSE PLATE AND TAIL LAMPS	67	CAN Communication System Description	97
Component Parts and Harness Connector Loca- tion	67	Schematic	98
System Description	67	Wiring Diagram - ILL -	99
CAN Communication System Description	68	Bulb Replacement	104
		Removal and Installation	105
		BULB SPECIFICATIONS	106
		Headlamp	106
		Exterior Lamp	106
		Interior Lamp/Illumination	106

PRECAUTIONS

< SERVICE INFORMATION >

SERVICE INFORMATION

PRECAUTIONS

Precaution for Supplemental Restraint System (SRS) "AIR BAG" and "SEAT BELT PRE-TENSIONER"

INFOID:000000004409087

The Supplemental Restraint System such as "AIR BAG" and "SEAT BELT PRE-TENSIONER", used along with a front seat belt, helps to reduce the risk or severity of injury to the driver and front passenger for certain types of collision. This system includes seat belt switch inputs and dual stage front air bag modules. The SRS system uses the seat belt switches to determine the front air bag deployment, and may only deploy one front air bag, depending on the severity of a collision and whether the front occupants are belted or unbelted. Information necessary to service the system safely is included in the SRS and SB section of this Service Manual.

WARNING:

- To avoid rendering the SRS inoperative, which could increase the risk of personal injury or death in the event of a collision which would result in air bag inflation, all maintenance must be performed by an authorized NISSAN/INFINITI dealer.
- Improper maintenance, including incorrect removal and installation of the SRS, can lead to personal injury caused by unintentional activation of the system. For removal of Spiral Cable and Air Bag Module, see the SRS section.
- Do not use electrical test equipment on any circuit related to the SRS unless instructed to in this Service Manual. SRS wiring harnesses can be identified by yellow and/or orange harnesses or harness connectors.

A
B
C
D
E
F
G
H
I
J
LT
L
M
N
O
P

HEADLAMP (FOR USA)

< SERVICE INFORMATION >

HEADLAMP (FOR USA)

Component Parts and Harness Connector Location

INFOID:000000004409088

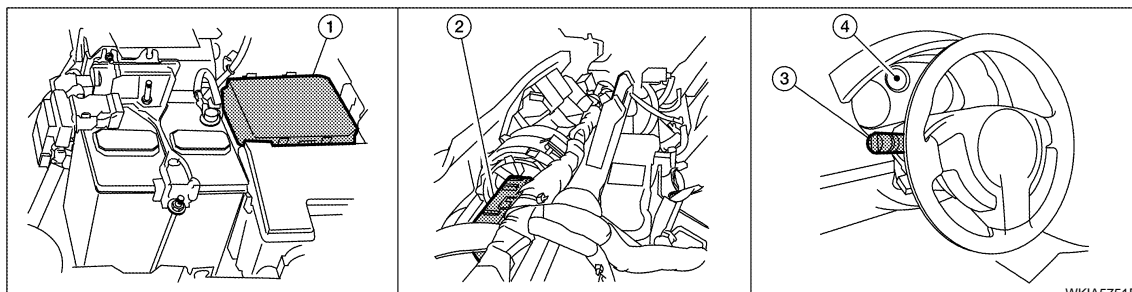

1. IPDM E/R E46, E47 and E48
2. BCM M18 and M20 (view with instrument panel removed)
3. Combination switch (lighting switch) M28
4. Combination meter M24

System Description

INFOID:000000004409089

Headlamp operation is controlled by the BCM (body control module) based on inputs from the combination switch (lighting switch). When the lighting switch is placed in the 2ND position, the BCM receives an input signal requesting the headlamps (and tail lamps) illuminate. The BCM sends a signal, via the CAN communication lines, to the IPDM E/R (intelligent power distribution module engine room) requesting the headlamps be turned ON. The CPU (central processing unit) located in the IPDM E/R controls ground for the headlamp high and headlamp low relay coils. These relays direct power to the respective headlamps, which then illuminate.

OUTLINE

Power is supplied at all times

- to headlamp high relay RH and LH (located in IPDM E/R),
- to headlamp low relay (located in IPDM E/R),
- to ignition relay (located in IPDM E/R),
- through 15A fuse (No. 52, located in IPDM E/R) and
- through 20A fuse (No. 53, located in IPDM E/R)
- to CPU located in IPDM E/R,
- through 50A fusible link (letter j, located in fuse and fusible link block)
- to BCM terminal 70,
- through 10A fuse [No. 21, located in fuse block (J/B)]
- to BCM terminal 57, and
- through 10A fuse [No. 19, located in fuse block (J/B)]
- to combination meter terminal 1.

With the ignition switch in the ON or START position, power is supplied

- to the ignition relay (located in IPDM E/R),
- through 10A fuse [No. 12, located in fuse block (J/B)]
- to BCM terminal 38,
- through 10A fuse [No. 14, located in fuse block (J/B)]
- to combination meter terminal 2.

With the ignition switch in the ACC or ON position, power is supplied

- through 10A fuse [No. 6, located in fuse block (J/B)]
- to BCM terminal 11.

Ground is supplied

- to BCM terminal 67
- to combination meter terminals 3 and 21
- through grounds M57 and M61, and
- to IPDM E/R terminals 39 and 59
- through grounds E9, E15 (all models) and E24 (with MR20DE).

HEADLAMP OPERATION

Low Beam Operation

HEADLAMP (FOR USA)

< SERVICE INFORMATION >

With the lighting switch in 2ND position, the BCM receives an input signal requesting the headlamps to illuminate. The BCM then sends a signal, via the CAN communication lines, to the IPDM E/R requesting the low beam headlamps be turned ON. The CPU located in the IPDM E/R controls ground to the headlamp low relay coil, which when energized, directs power

- through 15A fuse (No. 41, located in IPDM E/R)
- through IPDM E/R terminal 54
- to headlamp RH terminal 3, and
- through 15A fuse (No. 40, located in IPDM E/R)
- through IPDM E/R terminal 52
- to headlamp LH terminal 3.

Ground is supplied

- to headlamp RH and LH terminals 5
- through grounds E9, E15 (all models) and E24 (with MR20DE).

With power and ground supplied, low beam headlamps illuminate.

High Beam Operation/Flash-to-Pass Operation

With the lighting switch in 2ND position and high beam switch in the HIGH position, the BCM receives an input signal requesting the headlamp high beams to illuminate. The flash to pass feature can be used any time and also sends a signal to the BCM. This input signal is then communicated to the IPDM E/R and the combination meter via the CAN communication lines. The CPU located in the IPDM E/R controls the headlamp high relays (LH and RH), which when energized, directs power

- through 10A fuse (No. 34, located in IPDM E/R)
- through IPDM E/R terminal 56
- to headlamp RH terminal 6, and
- through 10A fuse (No. 35, located in IPDM E/R)
- through IPDM E/R terminal 55
- to headlamp LH terminal 6.

Ground is supplied

- to headlamp RH and LH terminal 5
- through grounds E9, E15 (all models) and E24 (with MR20DE).

With power and ground supplied, the high beam headlamps illuminate.

The BCM sends a signal, via the CAN communication lines, to the combination meter requesting the high beam indicator lamp be turned ON.

COMBINATION SWITCH READING FUNCTION

Refer to [LT-59, "Combination Switch Reading Function"](#).

CAN COMMUNICATION SYSTEM DESCRIPTION

Refer to [LAN-6, "System Description"](#).

A
B
C
D
E
F
G
H
I
J
L
M
N
O
P

INFOID:000000004409090

LT

HEADLAMP (FOR USA)

< SERVICE INFORMATION >

Schematic

INFOID:000000004409091

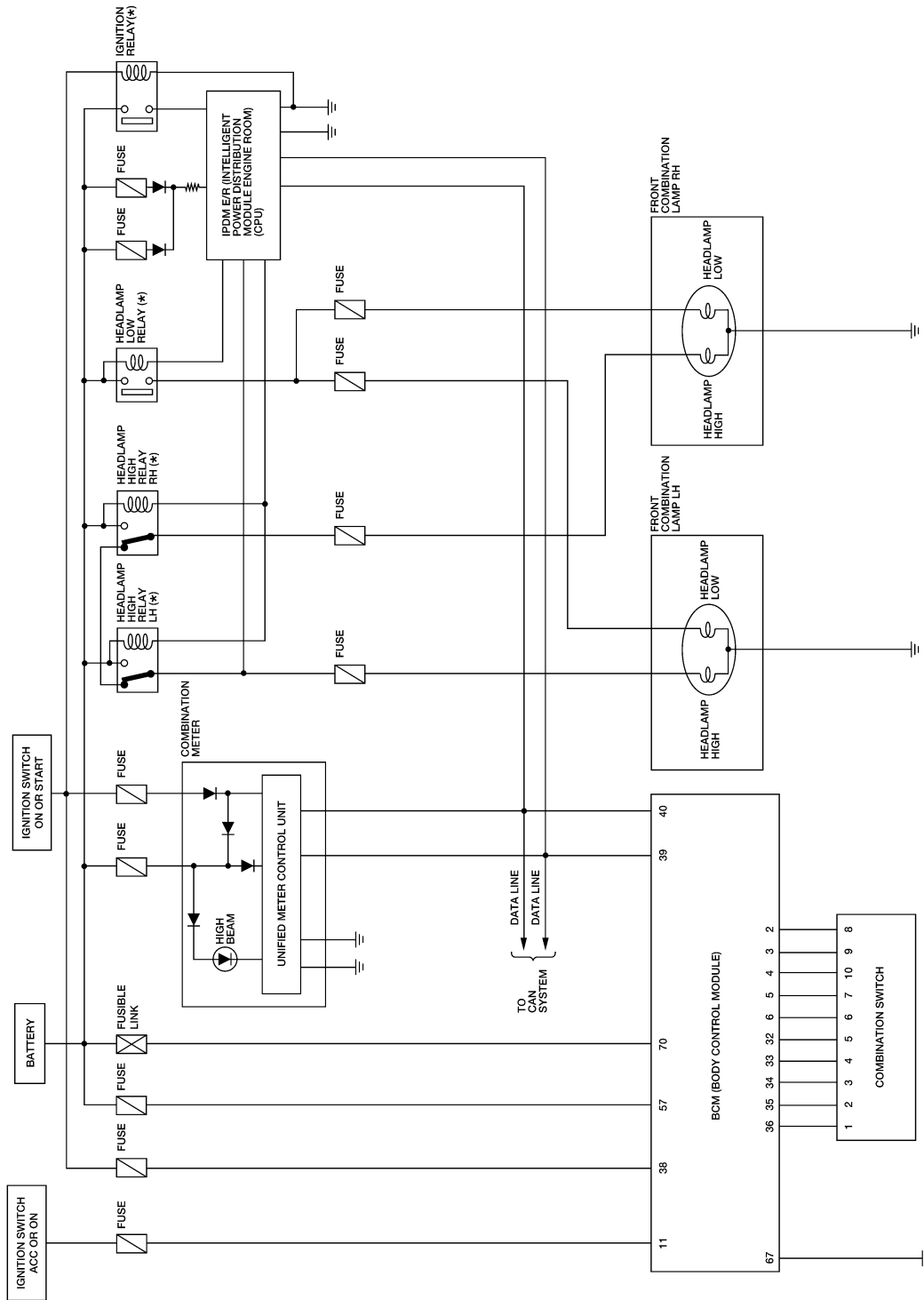

* : THIS RELAY IS BUILT INTO THE IPDM E/R (INTELLIGENT POWER DISTRIBUTION MODULE ENGINE ROOM)

BKWA0779E

HEADLAMP (FOR USA)

< SERVICE INFORMATION >

Wiring Diagram

INFOID:000000004409092

LT-H/LAMP-01

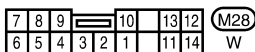
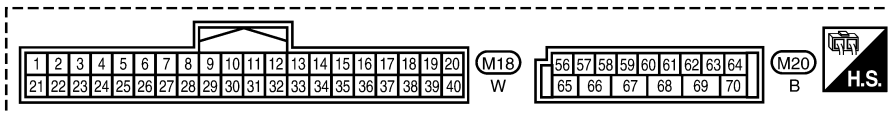
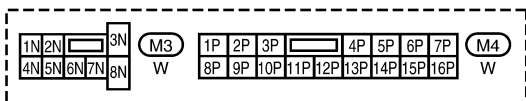
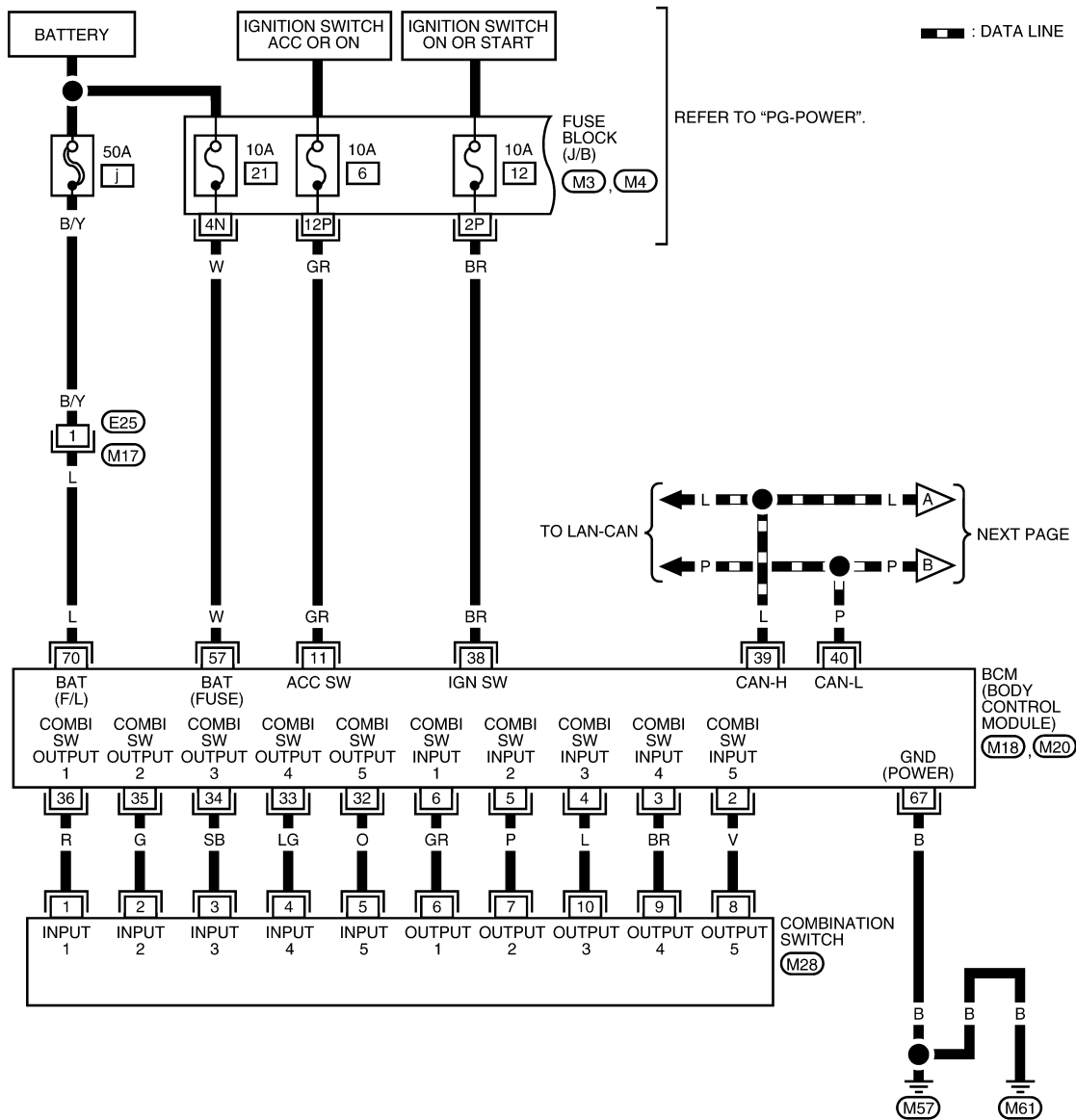

BKWA0780E

HEADLAMP (FOR USA)

< SERVICE INFORMATION >

LT-H/LAMP-02

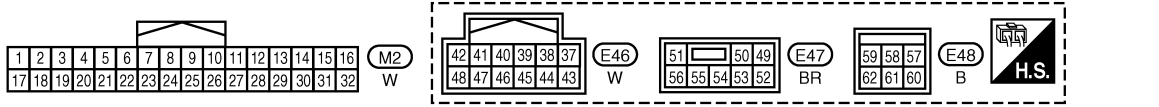
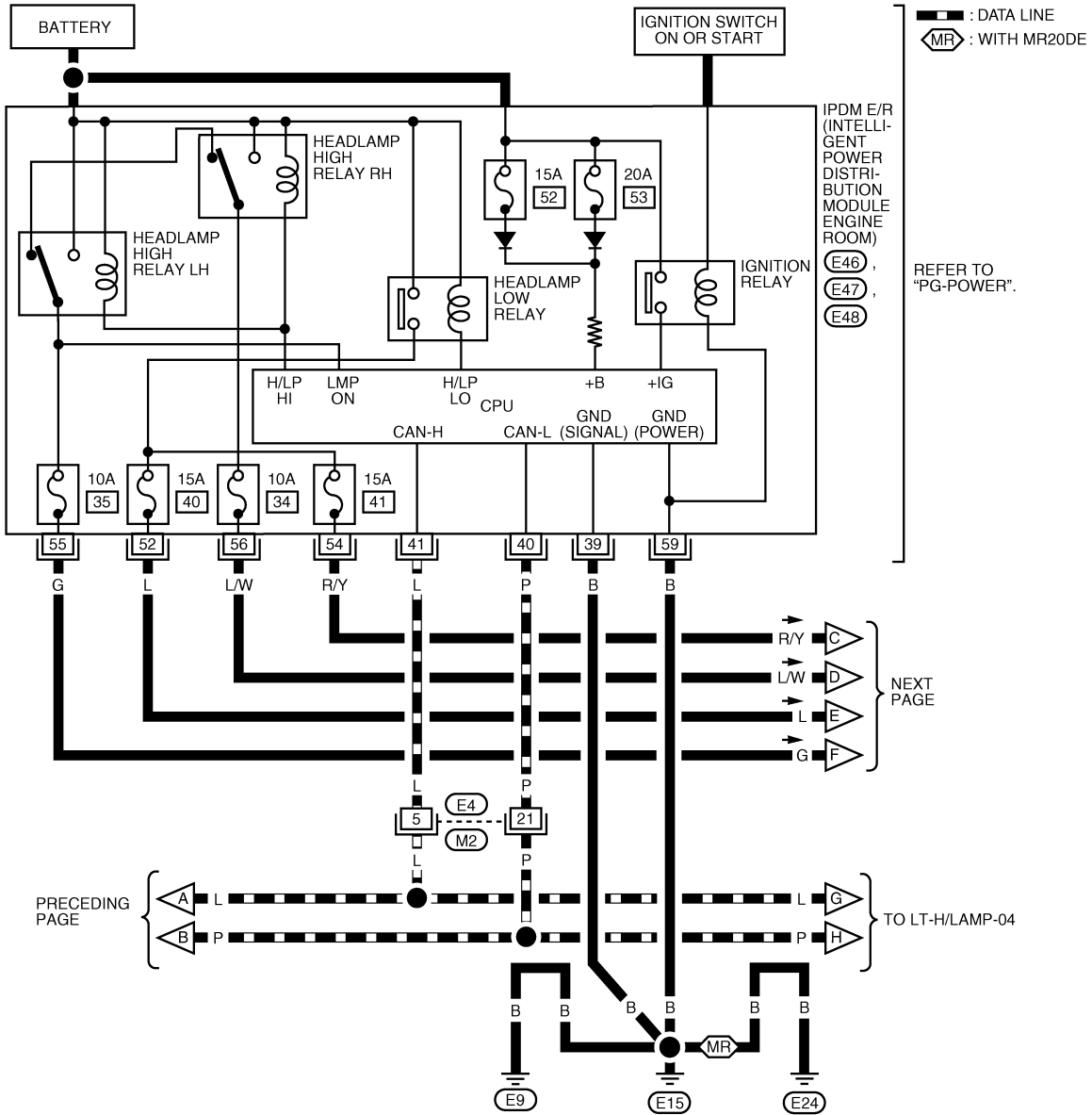

BKWA0832E

HEADLAMP (FOR USA)

< SERVICE INFORMATION >

LT-H/LAMP-03

MR : WITH MR20DE

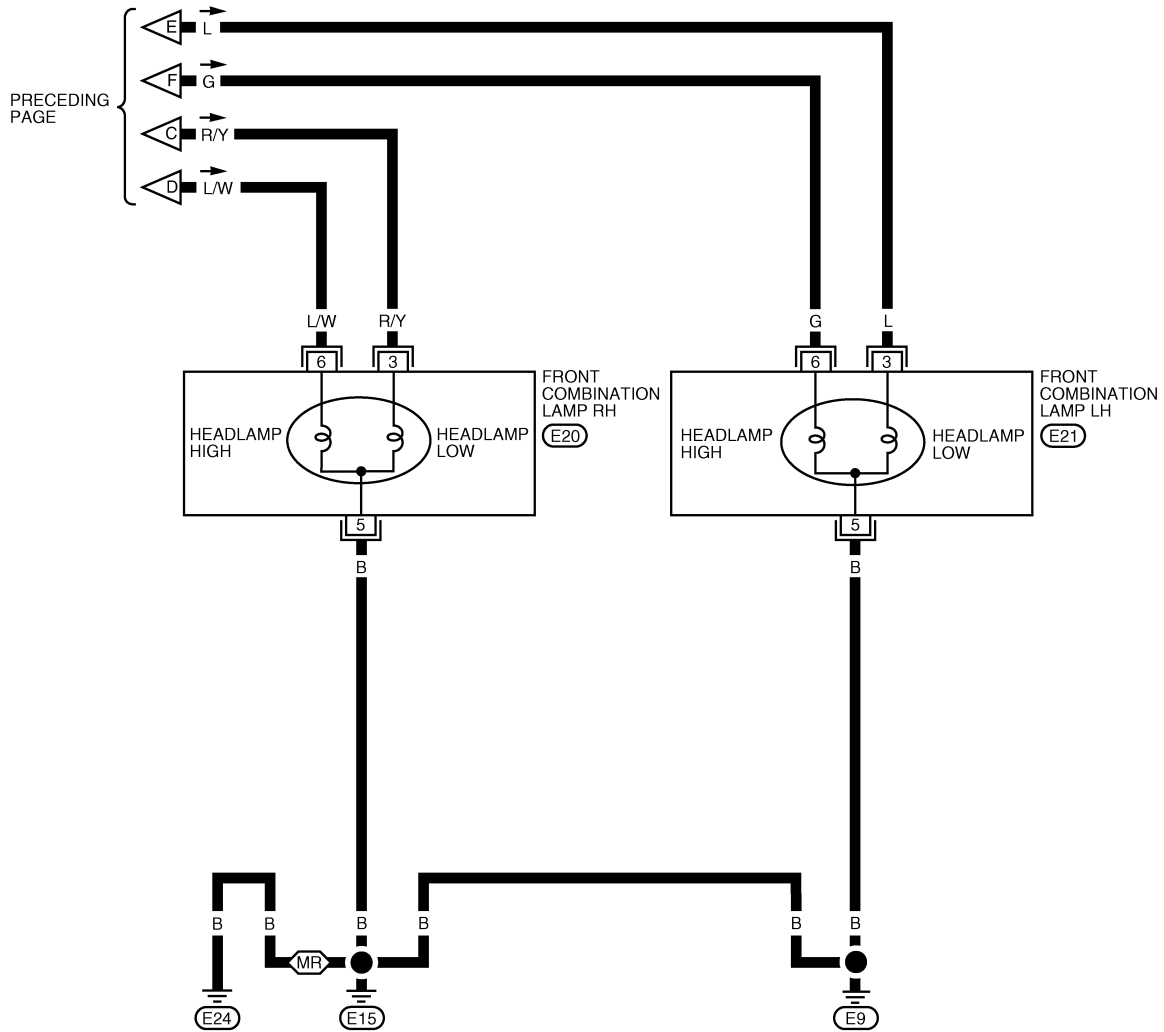

BKWA0833E

A
B
C
D
E
F
G
H
I
J
K
L
M
N
O
P

LT

HEADLAMP (FOR USA)

< SERVICE INFORMATION >

LT-H/LAMP-04

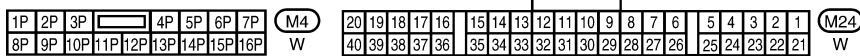
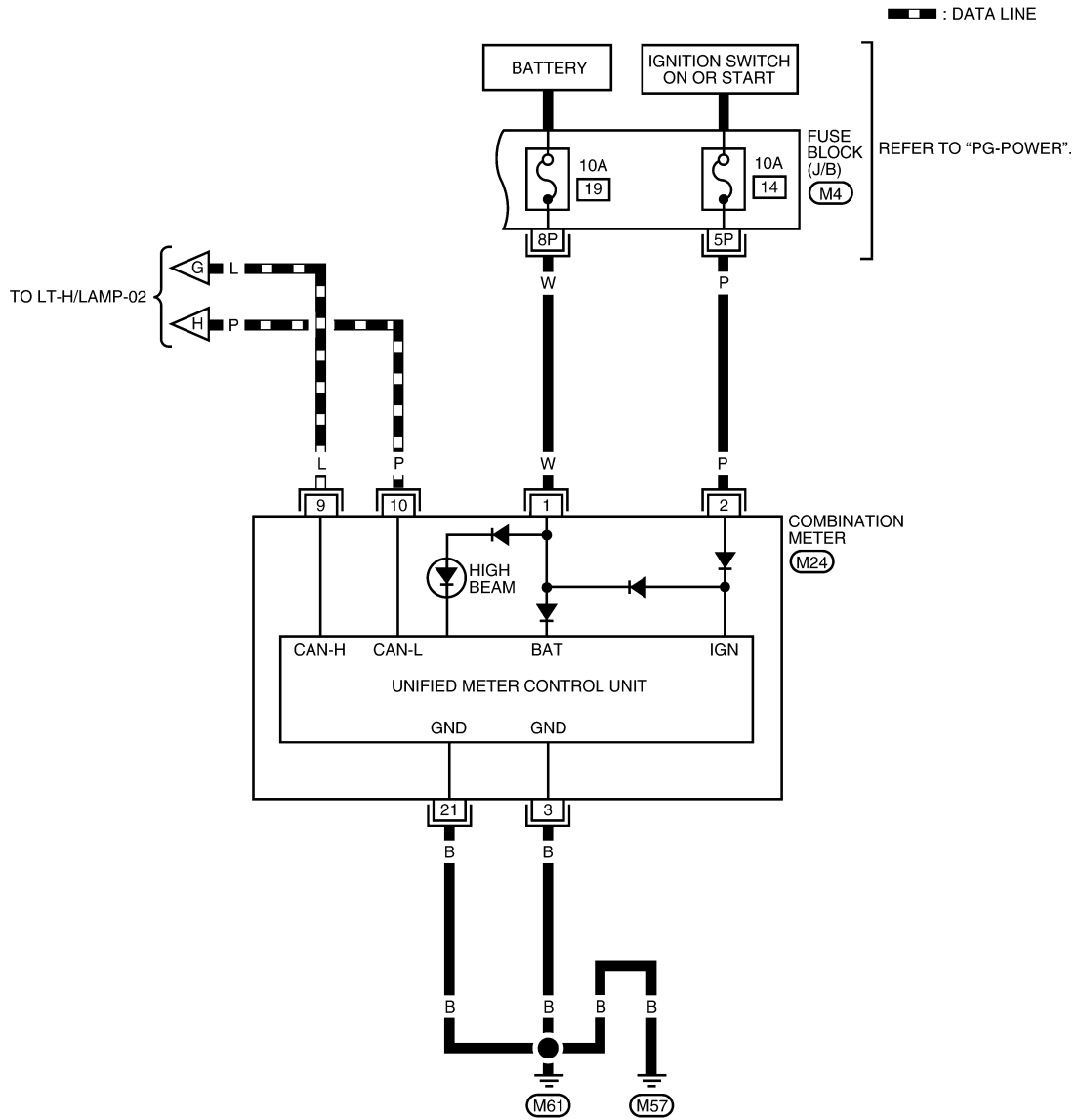

Terminal and Reference Value for BCM

Refer to [BCS-11, "Terminal and Reference Value for BCM"](#).

Terminal and Reference Value for IPDM E/R

Refer to [PG-24, "Terminal and Reference Value for IPDM E/R"](#).

BKWA0783E

INFOID:000000004409093

INFOID:000000004409094

HEADLAMP (FOR USA)

< SERVICE INFORMATION >

How to Perform Trouble Diagnosis

INFOID:000000004409095

1. Confirm the symptom or customer complaint.
2. Understand operation, description and function description. Refer to [LT-4, "System Description"](#).
3. Perform the Preliminary Check. Refer to [LT-11, "Preliminary Check"](#).
4. Check symptom and repair or replace the cause of the malfunction.
5. Do the headlamps operate normally? If YES, GO TO 6. If NO, GO TO 4.
6. Inspection end.

Preliminary Check

INFOID:000000004409096

CHECK POWER SUPPLY AND GROUND CIRCUIT FOR BCM

Refer to [BCS-14, "BCM Power Supply and Ground Circuit Inspection"](#).

CHECK POWER SUPPLY AND GROUND CIRCUIT FOR IPDM E/R

Refer to [PG-26, "IPDM E/R Power/Ground Circuit Inspection"](#).

CONSULT-III Function (BCM)

INFOID:000000004409097

CONSULT-III can display each diagnostic item using the diagnostic test modes shown following.

BCM diagnostic test item	Diagnostic mode	Description
Inspection by part	WORK SUPPORT	Supports inspections and adjustments. Commands are transmitted to the BCM for setting the status suitable for required operation, input/output signals are received from the BCM and received data is displayed.
	DATA MONITOR	Displays BCM input/output data in real time.
	ACTIVE TEST	Operation of electrical loads can be checked by sending drive signal to them.
	SELF-DIAG RESULTS	Displays BCM self-diagnosis results.
	CAN DIAG SUPPORT MNTR	The result of transmit/receive diagnosis of CAN communication can be read.
	ECU PART NUMBER	BCM part number can be read.
	CONFIGURATION	Performs BCM configuration read/write functions.

WORK SUPPORT

Display Item List

Item	Description	CONSULT-III	Factory setting
BATTERY SAVER SET	Exterior lamp battery saver control mode can be changed in this mode. Selects exterior lamp battery saver control mode between ON/OFF.	ON	×
		OFF	—

DATA MONITOR

Display Item List

Monitor item	Contents
IGN ON SW	"ON/OFF" Displays "IGN position (ON)/OFF, ACC position (OFF)" judged from the ignition switch signal.
ACC ON SW	"ON/OFF" Displays "ACC (ON)/OFF, Ignition OFF (OFF)" status judged from ignition switch signal.
HI BEAM SW	"ON/OFF" Displays status (high beam switch: ON/Others: OFF) of high beam switch judged from lighting switch signal.
HEAD LAMP SW 1	"ON/OFF" Displays status (headlamp switch 1: ON/Others: OFF) of headlamp switch 2 judged from lighting switch signal.
HEAD LAMP SW 2	"ON/OFF" Displays status (headlamp switch 2: ON/Others: OFF) of headlamp switch 2 judged from lighting switch signal.

HEADLAMP (FOR USA)

< SERVICE INFORMATION >

Monitor item	Contents
LIGHT SW 1ST "ON/OFF"	Displays status (lighting switch 1st position: ON/Others: OFF) of lighting switch judged from lighting switch signal.
PASSING SW "ON/OFF"	Displays status (flash-to-pass switch: ON/Others: OFF) of flash-to-pass switch judged from lighting switch signal.
FR FOG SW "ON/OFF"	Displays status (front fog lamp switch: ON/Others: OFF) of front fog lamp switch judged from lighting switch signal.
DOOR SW - DR "ON/OFF"	Displays status of the front door LH as judged from the front door switch LH signal. (Door is open: ON/Door is closed: OFF)
DOOR SW - AS "ON/OFF"	Displays status of the front door RH as judged from the front door switch RH signal. (Door is open: ON/Door is closed: OFF)
DOOR SW - RR "ON/OFF"	Displays status of the rear door as judged from the rear door switch (RH) signal. (Door is open: ON/Door is closed: OFF)
DOOR SW - RL "ON/OFF"	Displays status of the rear door as judged from the rear door switch (LH) signal. (Door is open: ON/Door is closed: OFF)
TURN SIGNAL R "ON/OFF"	Displays status (Turn right: ON/Others: OFF) as judged from lighting switch signal.
TURN SIGNAL L "ON/OFF"	Displays status (Turn left: ON/Others: OFF) as judged from lighting switch signal.
ENGINE RUN ^{Note 1} "ON/OFF"	Displays status (Engine running: ON/Others: OFF) as judged from engine status signal.
PKB SW ^{Note 1} "ON/OFF"	Displays status (Parking brake switch: ON/Others: OFF) as judged from parking brake switch signal.

Note 1: Vehicles without daytime light system may display this item, but cannot monitor it.

ACTIVE TEST

Display Item List

Test item	Description
TAIL LAMP	Allows tail lamp relay to operate by switching ON-OFF.
HEAD LAMP	Allows headlamp relay (HI, LO) to operate by switching ON-OFF.
FR FOG LAMP	Allows fog lamp relay to operate by switching ON-OFF.

SELF-DIAGNOSTIC RESULTS

Display Item List

Monitored item	CONSULT-III display	Description
CAN communication	CAN communication [U1000]	Malfunction is detected in CAN communication.
CAN communication system	CAN communication system 1 to 6 [U1000]	Malfunction is detected in CAN system.

CONSULT-III Function (IPDM E/R)

INFOID:000000004409098

CONSULT-III can display each diagnostic item using the diagnostic test modes shown following.

IPDM E/R diagnostic Mode	Description
SELF-DIAG RESULTS	Displays IPDM E/R self-diagnosis results.
DATA MONITOR	Displays IPDM E/R input/output data in real time.
CAN DIAG SUPPORT MNTR	The result of transmit/receive diagnosis of CAN communication can be read.
ACTIVE TEST	Operation of electrical loads can be checked by sending drive signal to them.

DATA MONITOR

All Signals, Main Signals, Selection from Menu

HEADLAMP (FOR USA)

< SERVICE INFORMATION >

Item name	CONSULT-III screen display	Display or unit	Monitor item selection			Description
			ALL SIGNALS	MAIN SIGNALS	SELECTION FROM MENU	
Parking, license plate and tail lamps request	TAIL&CLR REQ	ON/OFF	×	×	×	Signal status input from BCM
Headlamp low beam request	HL LO REQ	ON/OFF	×	×	×	Signal status input from BCM
Headlamp high beam request	HL HI REQ	ON/OFF	×	×	×	Signal status input from BCM
Front fog lamps request	FR FOG REQ	ON/OFF	×	×	×	Signal status input from BCM
Daytime light request	DTRL REQ	ON/OFF	x	x	x	Signal status input from BCM

NOTE:

Perform monitoring of IPDM E/R data with the ignition switch ON. When the ignition switch is at ACC, the display may not be correct.

ACTIVE TEST

Test item	CONSULT-III screen display	Description
Tail lamp relay output	TAIL LAMP	Allows tail lamp relay to operate by switching operation ON-OFF at your option.
Headlamp relay (HI, LO) output	EXTERNAL LAMPS	Allows headlamp relay (HI, LO) to operate by switching operation (OFF, HI, LO) at your option (Head lamp high beam repeats ON-OFF every 1 second).
Front fog lamp relay (FOG) output		Allows fog lamp relay (FOG) to operate by switching operation ON-OFF at your option.

Headlamp High Beam Does Not Illuminate (Both Sides)

INFOID:000000004409099

1. CHECK COMBINATION SWITCH INPUT SIGNAL

☑ With CONSULT-III

- Select "BCM" on CONSULT-III. Select "HEAD LAMP" on "SELECT TEST ITEM" screen.
- Select "DATA MONITOR". Make sure that "HI BEAM SW" turns ON-OFF linked with operation of lighting switch.

When lighting switch is high : HI BEAM SW ON position

☒ Without CONSULT-III

Refer to [LT-60, "Combination Switch Inspection"](#).

OK or NG

OK >> GO TO 2.

NG >> Check combination switch (lighting switch). Refer to [LT-60, "Combination Switch Inspection"](#).

2. HEADLAMP ACTIVE TEST

☑ With CONSULT-III

- Select "IPDM E/R" on CONSULT-III. Select "ACTIVE TEST".
- Select "LAMPS" on "SELECT TEST ITEM" screen.
- Touch "HI" screen.
- Make sure headlamp high beam operates.

Headlamp high beam should operate (Headlamp high beam repeats ON-OFF every 2 seconds).

☒ Without CONSULT-III

- Start auto active test. Refer to [PG-20, "Auto Active Test"](#).
- Make sure headlamp high beam operates.

HEADLAMP (FOR USA)

< SERVICE INFORMATION >

Headlamp high beam should operate.

OK or NG

- OK >> GO TO 3.
- NG >> GO TO 4.

3. CHECK IPDM E/R

1. Select "IPDM E/R" on CONSULT-III. Select "DATA MONITOR".
2. Make sure "HL HI REQ" turns ON when lighting switch is in high position.

When lighting switch is high : HL HI REQ ON position

OK or NG

- OK >> Replace IPDM E/R. Refer to [PG-27, "Removal and Installation of IPDM E/R"](#).
- NG >> Replace BCM. Refer to [BCS-17, "Removal and Installation of BCM"](#).

4. HEADLAMP HIGH BEAM FUSE INSPECTION

Inspect 10A fuse [No. 34 (RH) and No. 35 (LH), located in the IPDM E/R].

OK or NG

- OK >> GO TO 5.
- NG >> Repair harness.

5. BULB INSPECTION

Inspect inoperative headlamp bulbs.

OK or NG

- OK >> GO TO 6.
- NG >> Replace headlamp bulb. Refer to [LT-22, "Bulb Replacement"](#).

6. CHECK HEADLAMP INPUT SIGNAL

Ⓜ With CONSULT-III

1. Turn ignition switch OFF.
2. Disconnect headlamp connector.
3. Turn ignition switch ON.
4. Select "IPDM E/R" on CONSULT-III. Select "ACTIVE TEST".
5. Select "LAMPS" on "SELECT TEST ITEM" screen.
6. Touch "HI" screen.
7. When headlamp high beam is operating, check voltage between headlamp harness connector and ground (Headlamp high beam repeats ON-OFF every 2 seconds).

Terminal		Terminal	Voltage
(+)			
Headlamp connector		6	Ground
RH	E20		
LH	E21		

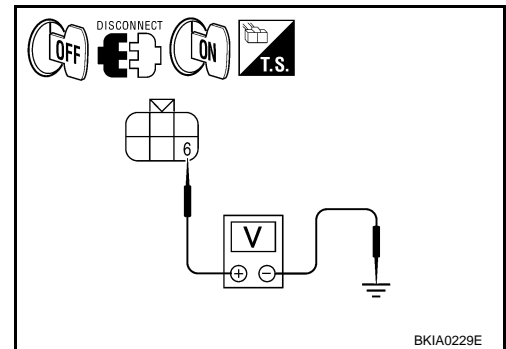

ⓧ Without CONSULT-III

1. Turn ignition switch OFF.
2. Disconnect headlamp connector.
3. Turn ignition switch ON.
4. Start auto active test. Refer to [PG-20, "Auto Active Test"](#).
5. When headlamp high beam is operating, check voltage between headlamp harness connector and ground.

HEADLAMP (FOR USA)

< SERVICE INFORMATION >

Terminal				Voltage
(+)		(-)		
Headlamp connector	Terminal			
RH	E20	6	Ground	Battery voltage
LH	E21			

OK or NG

- OK >> GO TO 7.
- NG >> GO TO 8.

7. CHECK HEADLAMP GROUND CIRCUIT

1. Turn ignition switch OFF.
2. Check continuity between headlamp harness connector and ground.

Headlamp connector		Terminal	Ground	Continuity
RH	E20	5		Ground
LH	E21			

OK or NG

- OK >> Check front combination lamp connector for damage or poor connection. Repair as necessary.
- NG >> Repair harness.

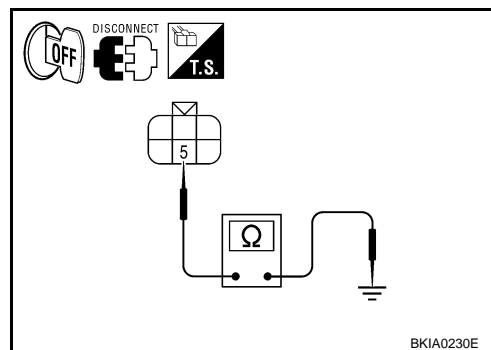

8. CHECK HEADLAMP CIRCUIT

1. Turn ignition switch OFF.
2. Disconnect IPDM E/R connector.
3. Check continuity between IPDM E/R harness connector (A) and headlamp harness connector (B).

Circuit	A		B		Continuity
	Connector	Terminal	Connector	Terminal	
RH	E47	56	E20	6	Yes
LH		55			

OK or NG

- OK >> Replace IPDM E/R. Refer to [PG-27. "Removal and Installation of IPDM E/R"](#).
- NG >> Repair harness or connector.

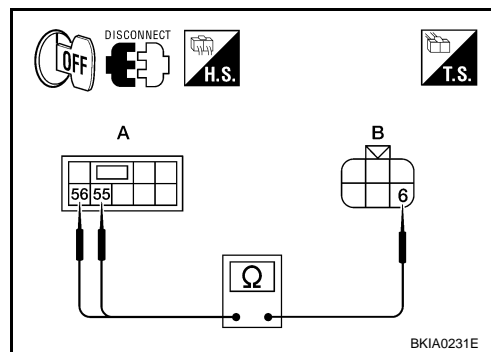

Headlamp High Beam Does Not Illuminate (One Side)

INFOID:000000004409100

1. HEADLAMP HIGH BEAM FUSE INSPECTION

Inspect 10A fuse [No. 34 (RH) or No. 35 (LH) located in IPDM E/R].

OK or NG

- OK >> GO TO 2.
- NG >> Repair harness.

2. CHECK BULB

Check headlamp bulb which does not illuminate.

OK or NG

- OK >> GO TO 3.
- NG >> Replace bulb. Refer to [LT-22. "Bulb Replacement"](#).

3. CHECK HEADLAMP INPUT SIGNAL

HEADLAMP (FOR USA)

< SERVICE INFORMATION >

1. Turn ignition switch OFF.
2. Disconnect headlamp connector.
3. Lighting switch is turned to HIGH position.
4. Check voltage between headlamp harness connector and ground.

Terminal (+)		Terminal (-)	Voltage
Headlamp connector	Terminal		
RH	E20	6	Ground
LH	E21		

OK or NG

- OK >> GO TO 4.
NG >> GO TO 5.

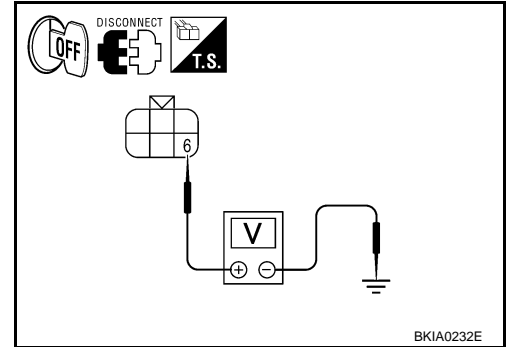

4. CHECK HEADLAMP GROUND CIRCUIT

1. Turn ignition switch OFF.
2. Check continuity between headlamp harness connector and ground.

Headlamp connector		Terminal	Ground	Continuity
RH	E20			Yes
LH	E21	5	Ground	Yes

OK or NG

- OK >> Check condition of headlamp harness connector.
NG >> Repair harness or connector.

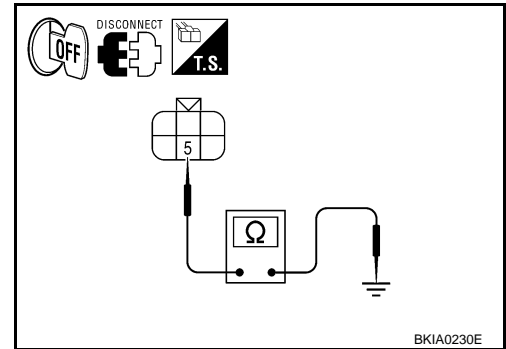

5. CHECK HEADLAMP CIRCUIT

1. Turn ignition switch OFF.
2. Disconnect IPDM E/R connector.
3. Check continuity between IPDM E/R harness connector (A) and headlamp harness connector (B).

Circuit	A		B		Continuity
	Connector	Terminal	Connector	Terminal	
RH	E47	56	E20	6	Yes
LH		55	E21		

OK or NG

- OK >> Replace IPDM E/R. Refer to [PG-27. "Removal and Installation of IPDM E/R"](#).
NG >> Repair harness or connector.

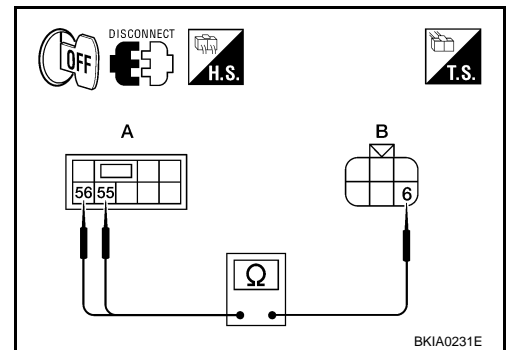

High Beam Indicator Lamp Does Not Illuminate

INFOID:000000004409101

1. BULB INSPECTION

Inspect CAN communication system. Refer to [LAN-15. "Trouble Diagnosis Flow Chart"](#).

OK or NG

- OK >> Replace combination meter. Refer to [DI-22. "Removal and Installation"](#).
NG >> Repair as necessary.

Headlamp Low Beam Does Not Illuminate (Both Sides)

INFOID:000000004409102

1. CHECK COMBINATION SWITCH INPUT SIGNAL

HEADLAMP (FOR USA)

< SERVICE INFORMATION >

④ With CONSULT-III

1. Select "BCM" on CONSULT-III. Select "HEAD LAMP".
2. Select "DATA MONITOR". Make sure that "HEAD LAMP SW 1" and "HEAD LAMP SW 2" turns ON-OFF linked with operation of lighting switch.

**When lighting switch is 2ND position : HEAD LAMP SW 1 ON
: HEAD LAMP SW 2 ON**

⊗ Without CONSULT-III

Refer to [LT-60, "Combination Switch Inspection"](#) .

OK or NG

OK >> GO TO 2.

NG >> Check combination switch (lighting switch). Refer to [LT-60, "Combination Switch Inspection"](#).

2.CHECK HEADLAMP ACTIVE TEST

④ With CONSULT-III

1. Select "IPDM E/R" on CONSULT-III. Select "ACTIVE TEST".
2. Select "LAMPS" on "SELECT TEST ITEM" screen.
3. Touch "LO" screen.
4. Make sure headlamp low beam operates.

Headlamp low beam should operate.

⊗ Without CONSULT-III

1. Start auto active test. Refer to [PG-20, "Auto Active Test"](#).
2. Make sure headlamp low beam operates.

Headlamp low beam should operate.

OK or NG

OK >> GO TO 3.

NG >> GO TO 4.

3.CHECK IPDM E/R

1. Select "IPDM E/R" on CONSULT-III. Select "DATA MONITOR".
2. Make sure "HL LO REQ" turns ON when lighting switch is in 2ND position.

When lighting switch is 2ND position : HL LO REQ ON

OK or NG

OK >> Replace IPDM E/R. Refer to [PG-27, "Removal and Installation of IPDM E/R"](#) .

NG >> Replace BCM. Refer to [BCS-17, "Removal and Installation of BCM"](#) .

4.HEADLAMP LOW BEAM FUSE INSPECTION

Inspect 15A fuse [No. 40 (LH) and No. 41 (RH) located in IPDM E/R].

OK or NG

OK >> GO TO 5.

NG >> Repair harness.

5.BULB INSPECTION

Inspect inoperative headlamp bulbs.

OK or NG

OK >> GO TO 6.

NG >> Replace headlamp bulb. Refer to [LT-22, "Bulb Replacement"](#) .

6.CHECK HEADLAMP INPUT SIGNAL

④ With CONSULT-III

1. Turn ignition switch OFF.
2. Disconnect headlamp connector.

HEADLAMP (FOR USA)

< SERVICE INFORMATION >

3. Turn ignition switch ON.
4. Select "IPDM E/R" on CONSULT-III. Select "ACTIVE TEST".
5. Select "LAMPS" on "SELECT TEST ITEM" screen.
6. Touch "LO" screen.
7. When headlamp low beam is operating, check voltage between headlamp harness connector and ground.

Terminal		Terminal	Voltage
(+)			
Headlamp connector		3	Ground
RH	E20		
LH	E21		

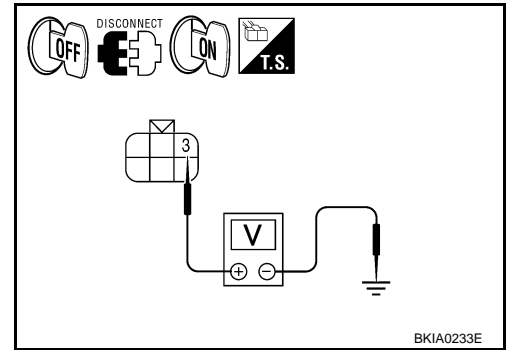

⊗ Without CONSULT-III

1. Turn ignition switch OFF.
2. Disconnect headlamp connector.
3. Turn ignition switch ON.
4. Start auto active test. Refer to [PG-20, "Auto Active Test"](#).
5. When headlamp low beam is operating, check voltage between headlamp harness connector and ground.

Terminal		Terminal	Voltage
(+)			
Headlamp connector		3	Ground
RH	E20		
LH	E21		

OK or NG

- OK >> GO TO 7.
 NG >> GO TO 8.

7. CHECK HEADLAMP GROUND CIRCUIT

1. Turn ignition switch OFF.
2. Check continuity between headlamp harness connector (B) and ground.

Headlamp connector		Terminal	Ground	Continuity
RH	E20	5		Ground
LH	E21			

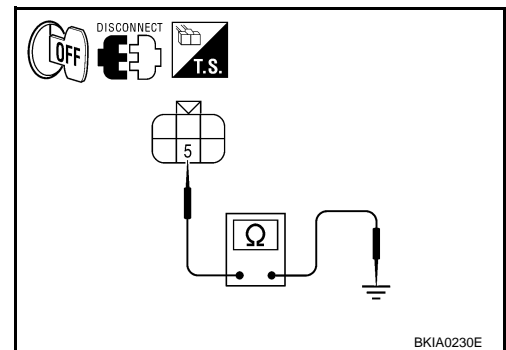

OK or NG

- OK >> Check front combination lamp connector for damage or poor connection. Repair as necessary.
 NG >> Repair harness.

8. CHECK HEADLAMP CIRCUIT

1. Turn ignition switch OFF.
2. Disconnect IPDM E/R connector.

HEADLAMP (FOR USA)

< SERVICE INFORMATION >

- Check continuity between IPDM E/R harness connector (A) and headlamp harness connector (B).

Circuit	A		B		Continuity
	Connector	Terminal	Connector	Terminal	
RH	E47	54	E20	3	Yes
LH		52	E21		

OK or NG

OK >> Replace IPDM E/R. Refer to [PG-27, "Removal and Installation of IPDM E/R"](#).

NG >> Repair harness or connector.

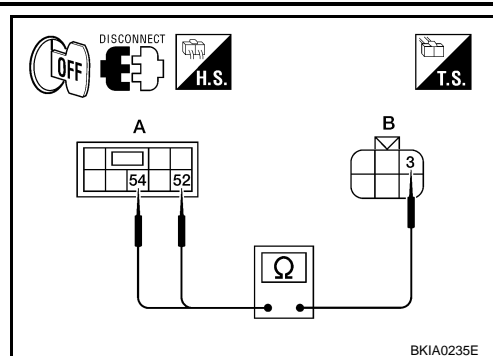

Headlamp Low Beam Does Not Illuminate (One Side)

INFOID:000000004409103

1. HEADLAMP LOW BEAM FUSE INSPECTION

Inspect 15A fuse [No. 40 (LH) and No. 41 (RH) located in IPDM E/R].

OK or NG

OK >> GO TO 2.

NG >> Repair harness.

2. CHECK BULB

Check bulb of headlamp which does not illuminate.

OK or NG

OK >> GO TO 3.

NG >> Replace bulb. Refer to [LT-22, "Bulb Replacement"](#).

3. CHECK HEADLAMP INPUT SIGNAL

- Turn ignition switch OFF.
- Disconnect headlamp connector.
- Lighting switch is turned to 2ND position.
- Check voltage between headlamp harness connector and ground.

Terminal		Voltage
(+)		
Headlamp connector	Terminal	
RH	E20	3
LH	E21	
		Ground
		Battery voltage

OK or NG

OK >> GO TO 4.

NG >> GO TO 5.

4. CHECK HEADLAMP GROUND CIRCUIT

- Turn ignition switch OFF.
- Check continuity between headlamp harness connector and ground.

Headlamp connector	Terminal	Ground	Continuity
RH	E20		5
LH	E21		

OK or NG

OK >> Check condition of headlamp harness connector.

NG >> Repair harness or connector.

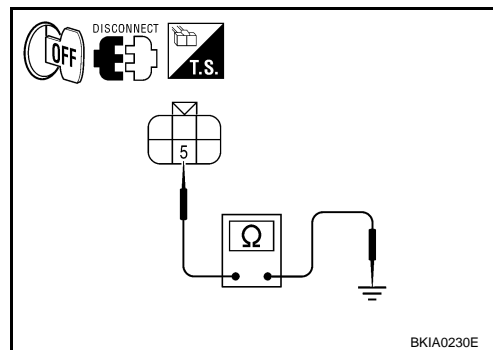
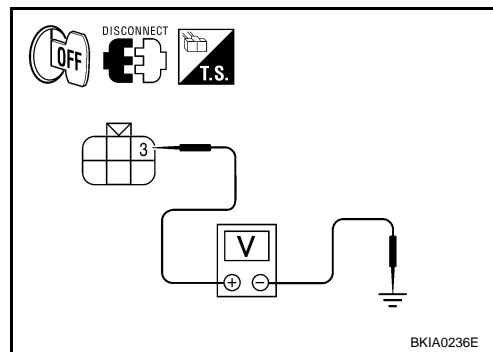

HEADLAMP (FOR USA)

< SERVICE INFORMATION >

5. CHECK HEADLAMP CIRCUIT

1. Turn ignition switch OFF.
2. Disconnect IPDM E/R connector.
3. Check continuity between IPDM E/R harness connector (A) and headlamp harness connector (B).

Circuit	A		B		Continuity
	Connector	Terminal	Connector	Terminal	
RH	E47	54	E20	3	Yes
LH		52	E21		

OK or NG

- OK >> Replace IPDM E/R. Refer to [PG-27, "Removal and Installation of IPDM E/R"](#) .
- NG >> Repair harness or connector.

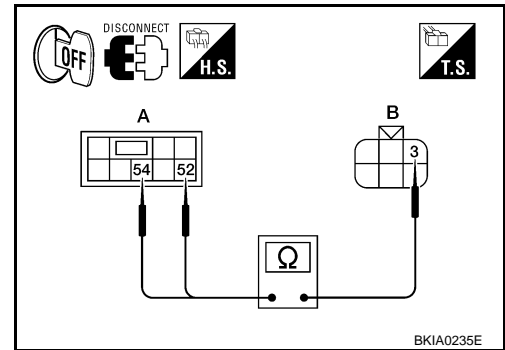

Headlamps Do Not Turn OFF

INFOID:000000004409104

1. CHECK HEADLAMPS TURN OFF

Make sure that lighting switch is OFF. Make sure headlamp turns OFF when ignition switch is turned OFF.

OK or NG

- OK >> GO TO 3.
- NG >> GO TO 2.

2. CHECK COMBINATION SWITCH INPUT SIGNAL

1. Select "BCM" on CONSULT-III. Select "HEAD LAMP" on "SELECT TEST ITEM" screen.
2. Select "DATA MONITOR". Make sure that "HEAD LAMP SW 1" and "HEAD LAMP SW 2" turns ON-OFF linked with operation of lighting switch.

When lighting switch is OFF : HEAD LAMP SW 1 OFF position : HEAD LAMP SW 2 OFF

OK or NG

- OK >> Replace IPDM E/R. Refer to [PG-27, "Removal and Installation of IPDM E/R"](#) .
- NG >> Check combination switch (lighting switch). Refer to [LT-60, "Combination Switch Inspection"](#) .

3. CHECKING CAN COMMUNICATIONS BETWEEN BCM AND IPDM E/R

Select "BCM" on CONSULT-III, and perform self-diagnosis for "BCM".

Display of self-diagnosis results

- NO DTC>> Replace IPDM E/R. Refer to [PG-27, "Removal and Installation of IPDM E/R"](#) .
- CAN COMM CIRCUIT>> Refer to [LAN-15, "Trouble Diagnosis Flow Chart"](#) .

HEADLAMP (FOR USA)

< SERVICE INFORMATION >

Aiming Adjustment

INFOID:000000004409105

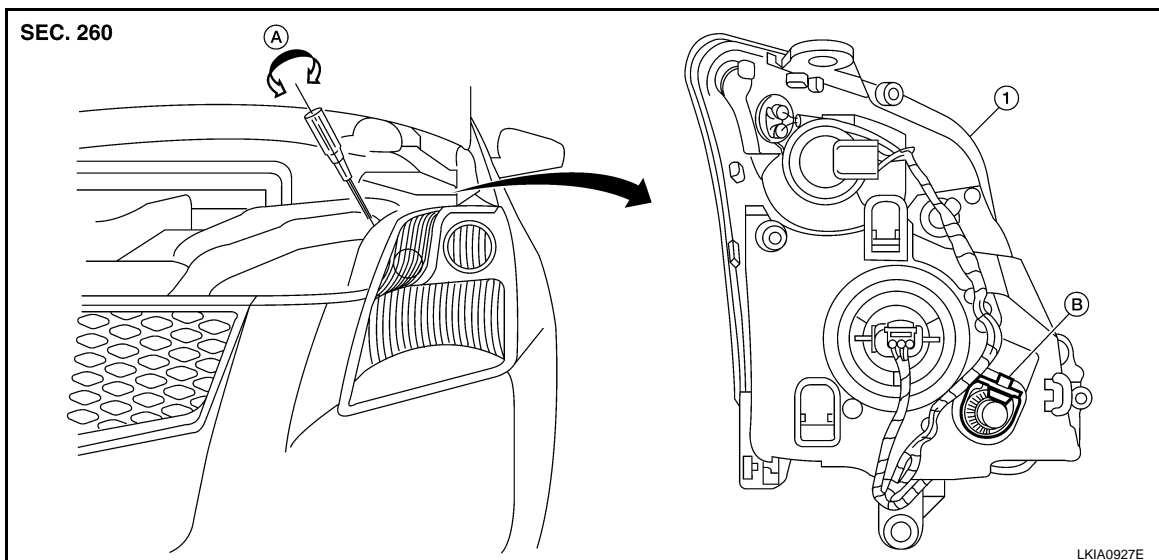

1. Headlamp

A. Inner and outer adjustment

B. Adjusting screw

PREPARATION BEFORE ADJUSTING

Before performing aiming adjustment, check the following.

1. Keep all tires inflated to correct pressures.
2. Place vehicle on level surface.
3. Set that there is no-load in vehicle other than the driver (or equivalent weight placed in driver's position).
Coolant, engine oil filled up to correct level and full fuel tank, spare tire, jack and tools are in place.

LOW BEAM AND HIGH BEAM

1. Turn headlamp low beam ON.
2. Use adjusting screw to perform aiming adjustment.

ADJUSTMENT USING AN ADJUSTMENT SCREEN (LIGHT/DARK BORDERLINE)

HEADLAMP (FOR USA)

< SERVICE INFORMATION >

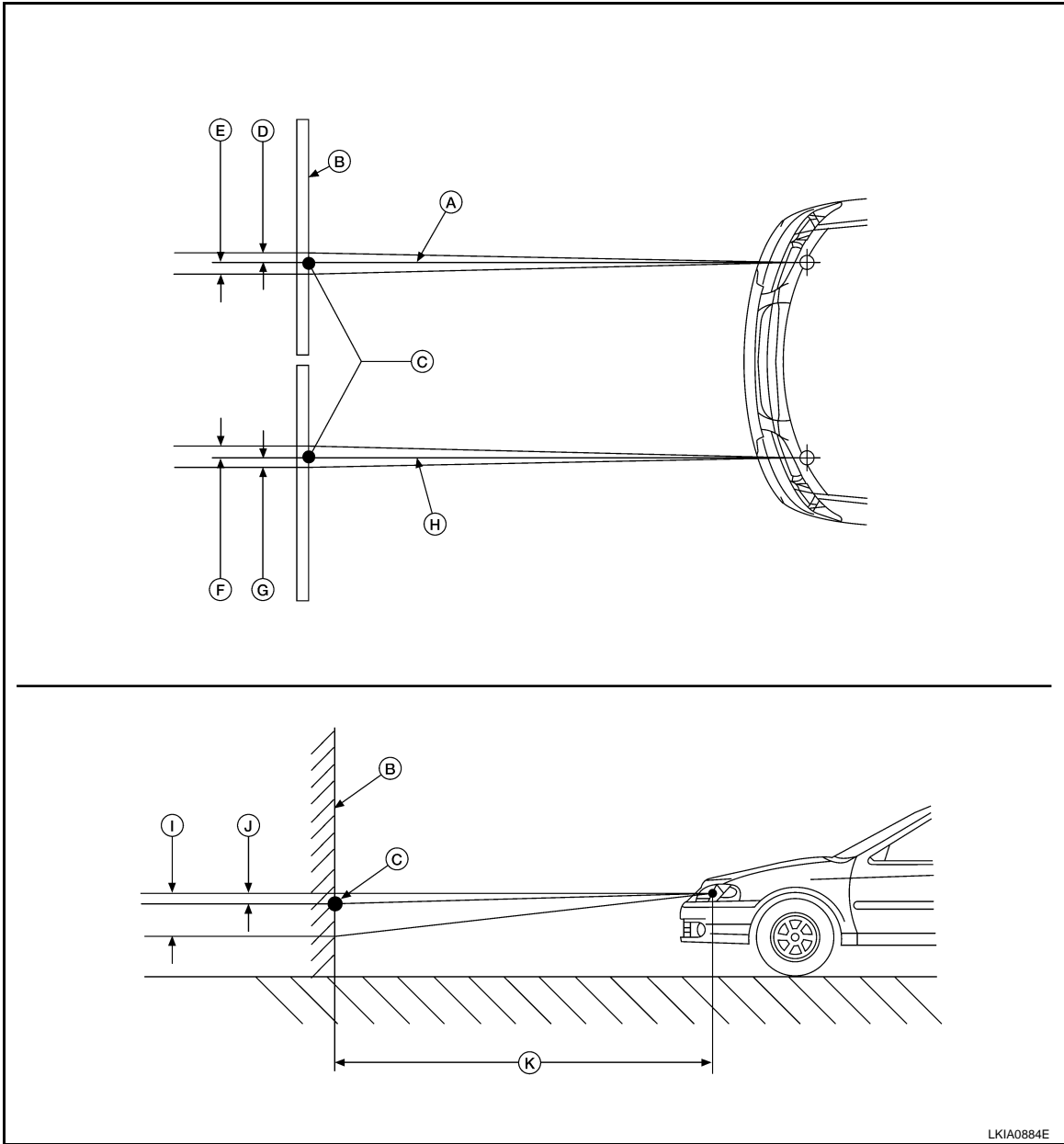

LKIA0884E

A.	Vertical center line of RH headlamp	B.	Adjustment screen	C.	Horizontal/Vertical center point of headlamp
D.	66.5 mm (2.6 in)	E.	66.5 mm (2.6 in)	F.	66.5 mm (2.6 in)
G.	66.5 mm (2.6 in)	H.	Vertical center line of LH headlamp	I.	53.2 mm (2.1 in)
J.	13.3 mm (0.5 in)	K.	7.62 m (25 ft)		

- Aim each headlamp individually and ensure other headlamp beam pattern is blocked from screen.
- For vertical headlamp aiming, adjust headlamp until beam pattern is positioned per specified dimensions.

Bulb Replacement

INFOID:000000004409106

HEADLAMP (HIGH/LOW)

Removal

1. Turn lighting switch OFF.
2. Turn the headlamp (high/low) bulb socket counterclockwise and remove.
3. Remove the headlamp (high/low) bulb.

HEADLAMP (FOR USA)

< SERVICE INFORMATION >

Installation

Installation is in the reverse order of removal.

HEADLAMP (HIGH/LOW) SE-R

Removal

1. Turn lighting switch OFF.
2. Remove the resonator LH. Refer to [EM-131](#).
3. Turn the headlamp (high/low) bulb socket counterclockwise and remove.
4. Remove the headlamp (high/low) bulb.

Installation

Installation is in the reverse order of removal.

PARKING (CLEARANCE) LAMP

Removal

1. Turn lighting switch OFF.
2. Turn the parking (clearance) lamp socket counterclockwise and remove.
3. Remove the parking (clearance) lamp bulb.

Installation

Installation is in the reverse order of removal.

FRONT TURN SIGNAL LAMP

Removal

1. Turn lighting switch OFF.
2. Turn the front turn signal lamp socket counterclockwise and remove.
3. Remove the front turn signal lamp bulb.

Installation

Installation is in the reverse order of removal.

PARKING LAMP

Removal

1. Turn lighting switch OFF.
2. Turn the parking lamp socket counterclockwise and remove.
3. Remove the front side marker lamp bulb.

Installation

Installation is in the reverse order of removal.

Removal and Installation

INFOID:000000004409107

REMOVAL

1. Disconnect the negative battery terminal.
2. Remove front bumper fascia. Refer to [EI-14](#).
3. Remove the headlamp bolts (A).
4. Pull the headlamp (1) toward the vehicle front, detach the harness clip, disconnect connector, and remove the headlamp.

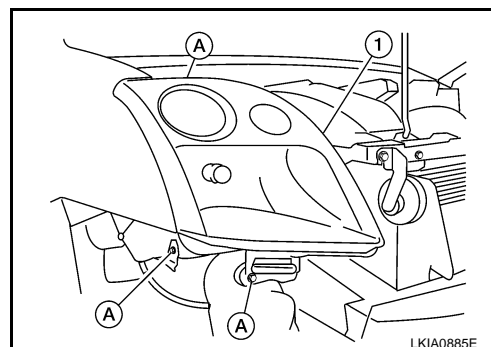

INSTALLATION

HEADLAMP (FOR USA)

< SERVICE INFORMATION >

Installation is in the reverse order of removal.

- After installation, perform aiming adjustment. Refer to [LT-21, "Aiming Adjustment"](#).

Disassembly and Assembly

INFOID:000000004409108

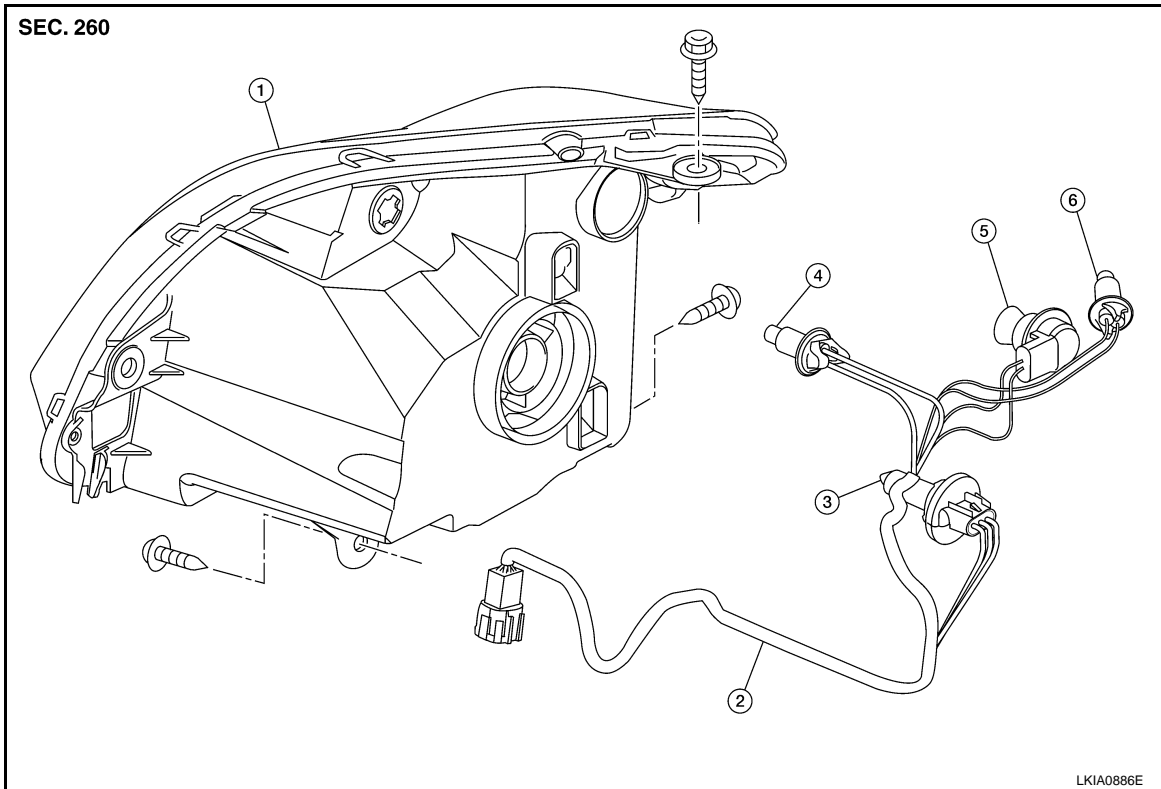

- | | | |
|---|---------------------------------------|-----------------------------------|
| 1. Headlamp housing assembly | 2. Headlamp housing assembly harness | 3. Halogen bulb (high/low) socket |
| 4. Parking (clearance) lamp bulb socket | 5. Front turn signal lamp bulb socket | 6. Parking lamp bulb socket |

DISASSEMBLY

1. Turn the halogen (high/low) bulb socket counterclockwise and remove.
2. Turn the parking (clearance) lamp bulb socket counterclockwise and remove.
3. Turn the front turn signal lamp bulb socket counterclockwise and remove.
4. Turn parking lamp bulb counterclockwise and remove.
5. Detach the headlamp bulb harness from the headlamp assembly.

ASSEMBLY

Assembly is in the reverse order of disassembly.

HEADLAMP (FOR CANADA) - DAYTIME LIGHT SYSTEM -

< SERVICE INFORMATION >

HEADLAMP (FOR CANADA) - DAYTIME LIGHT SYSTEM -

Component Parts and Harness Connector Location

INFOID:000000004409109

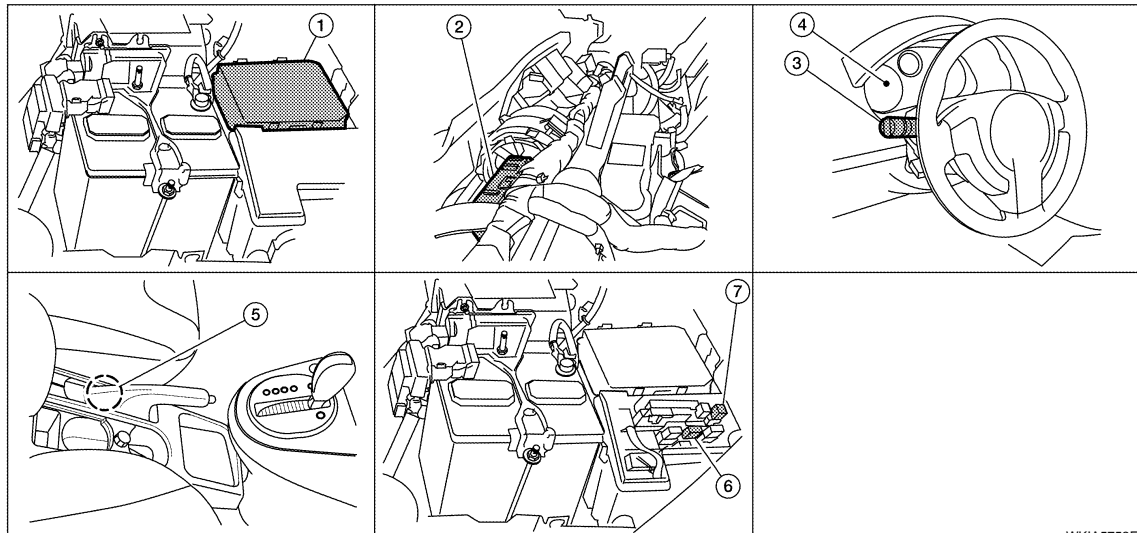

WKIA5752E

- | | | |
|------------------------------|---|---|
| 1. IPDM E/R E46, E47 and E48 | 2. BCM M18 and M20 (view with instrument panel removed) | 3. Combination switch (lighting switch) M28 |
| 4. Combination meter M24 | 5. Parking brake switch B24 | 6. Daytime Light Relay 1 |
| 7. Daytime Light Relay 2 | | |

System Description

INFOID:000000004409110

Headlamp operation is controlled by the BCM (body control module) based on inputs from the combination switch (lighting switch). When the lighting switch is placed in the 2ND position, the BCM receives an input signal requesting the headlamps (and tail lamps) illuminate. The request is then communicated to the IPDM E/R (intelligent power distribution module engine room) via the CAN communication lines. The CPU (central processing unit) located in the IPDM E/R controls ground for the headlamp high and headlamp low relay coils. These relays direct power to the respective headlamps, which then illuminate. When the headlamp switch is OFF or in the 1ST position (parking lamps ON), the parking brake is released and the engine is running, the IPDM E/R de-energizes the headlamp relays and supplies ground to the daytime light relay 1 to actuate the daytime light function.

OUTLINE

Power is supplied at all times

- to headlamp high relay RH and LH (located in IPDM E/R),
- to headlamp low relay (located in IPDM E/R),
- to ignition relay (located in IPDM E/R)
- through 15A fuse (No. 52, located in IPDM E/R) and
- through 20A fuse (No. 53, located in IPDM E/R)
- to CPU located in IPDM E/R,
- through 50A fusible link (letter j, located in fuse and fusible link box)
- to BCM terminal 70,
- through 10A fuse [No. 21, located in fuse block (J/B)]
- to BCM terminal 57,
- through 10A fuse [No. 19, located in fuse block (J/B)]
- to combination meter terminal 1,
- through 10A fuse (No. 27, located in fuse and fusible link box)
- to the daytime light relay 1 terminals 2 and 5.

With the ignition switch in the ON or START position, power is supplied

- to the ignition relay (located in IPDM E/R),
- through 10A fuse [No. 12, located in fuse block (J/B)]
- to BCM terminal 38,

HEADLAMP (FOR CANADA) - DAYTIME LIGHT SYSTEM -

< SERVICE INFORMATION >

- through 10A fuse [No. 14, located in fuse block (J/B)]
- to combination meter terminal 2.

With the ignition switch in the ACC or ON position, power is supplied

- through 10A fuse [No. 6, located in fuse block (J/B)]
- to BCM terminal 11.

Ground is supplied

- to BCM terminal 67 and
- to combination meter terminals 3 and 21
- through grounds M57 and M61,
- to IPDM E/R terminals 39 and 59
- through grounds E9, E15 (all models) and E24 (with MR20DE).

HEADLAMP OPERATION

Low Beam Operation

With the lighting switch in 2ND position, the BCM receives an input signal requesting the headlamps to illuminate. This input signal is communicated to the IPDM E/R via the CAN communication lines. The CPU located in the IPDM E/R controls the headlamp low relay coil, which when energized, directs power

- through 15A fuse (No. 41, located in IPDM E/R)
- through IPDM E/R terminal 54
- to front combination lamp RH terminal 3,
- through 15A fuse (No. 40, located in IPDM E/R)
- through IPDM E/R terminal 52
- to daytime light relay 2 terminals 1 and 3 (energizing the relay) and
- through daytime light relay 2 terminal 5
- to front combination lamp LH terminal 3.

Ground is supplied

- to front combination lamp RH terminal 5
- through grounds E9, E15 and E24,
- to headlamp LH terminal 5 via
- daytime light relay 1 terminals 3 and 4
- through grounds E9, E15 (all models) and E24 (with MR20DE).

With power and ground supplied, low beam headlamps illuminate.

High Beam/Flash-to-Pass Operation

With the lighting switch in 2ND position and high beam switch in the HIGH position, the BCM receives input signal requesting the headlamp high beams to illuminate. The flash-to-pass feature can be used any time and also sends a signal to the BCM. This input signal is communicated to the IPDM E/R and the combination meter via the CAN communication lines. The CPU located in the IPDM E/R controls the headlamp high relay coil, which when energized, directs power

- through 10A fuse (No. 34, located in IPDM E/R)
- through IPDM E/R terminal 56
- to front combination lamp RH terminal 6, and
- through 10A fuse (No. 35, located in IPDM E/R)
- through IPDM E/R terminal 55
- to front combination lamp LH terminal 6.

Ground is supplied

- to front combination lamp RH terminal 5
- through grounds E9, E15 (all models) and E24 (with MR20DE),
- to front combination lamp LH terminal 5 via
- daytime light relay 1 terminals 3 and 4
- through grounds E9, E15 (all models) and E24 (with MR20DE).

With power and ground supplied, the high beam headlamps illuminate.

The BCM sends a signal to the combination meter requesting the high beam indicator lamp to turn ON.

Daytime Light System Operation

With the lighting switch in the OFF or 1ST position (parking lamps ON), the BCM receives inputs requesting the headlights off. If the parking brake is released and the engine is running, the BCM then sends a signal, via the CAN communication lines, requesting the IPDM E/R to activate the daytime light system. The CPU located in the IPDM E/R controls the daytime light relay 1 coil, which when energized, directs power

- from daytime light relay 1 terminal 3
- to front combination lamp LH terminal 5,
- through front combination lamp LH high beam terminal 6

HEADLAMP (FOR CANADA) - DAYTIME LIGHT SYSTEM -

< SERVICE INFORMATION >

- to IPDM E/R terminal 55,
- through 10A fuse (No. 35, located in IPDM E/R) and
- through both de-energized headlamp high relays
- to 10A fuse (No. 34, located in IPDM E/R),
- through IPDM E/R terminal 56
- to front combination lamp RH high beam terminal 6.

Ground is supplied

- to front combination lamp RH terminal 5 and
- to daytime light relay 1 terminal 4
- through grounds E9, E15 (all models) and E24 (with MR20DE),
- to daytime light relay 1 terminal 1
- through IPDM E/R terminal 49.

With power and ground supplied, high beam headlamps illuminate at reduced intensity.

COMBINATION SWITCH READING FUNCTION

Refer to [LT-59, "Combination Switch Reading Function"](#).

CAN Communication System Description

Refer to [LAN-6, "System Description"](#).

INFOID:000000004409111

A
B
C
D
E
F
G
H
I
J
L
M
N
O
P

LT

HEADLAMP (FOR CANADA) - DAYTIME LIGHT SYSTEM -

< SERVICE INFORMATION >

Schematic

INFOID:000000004409112

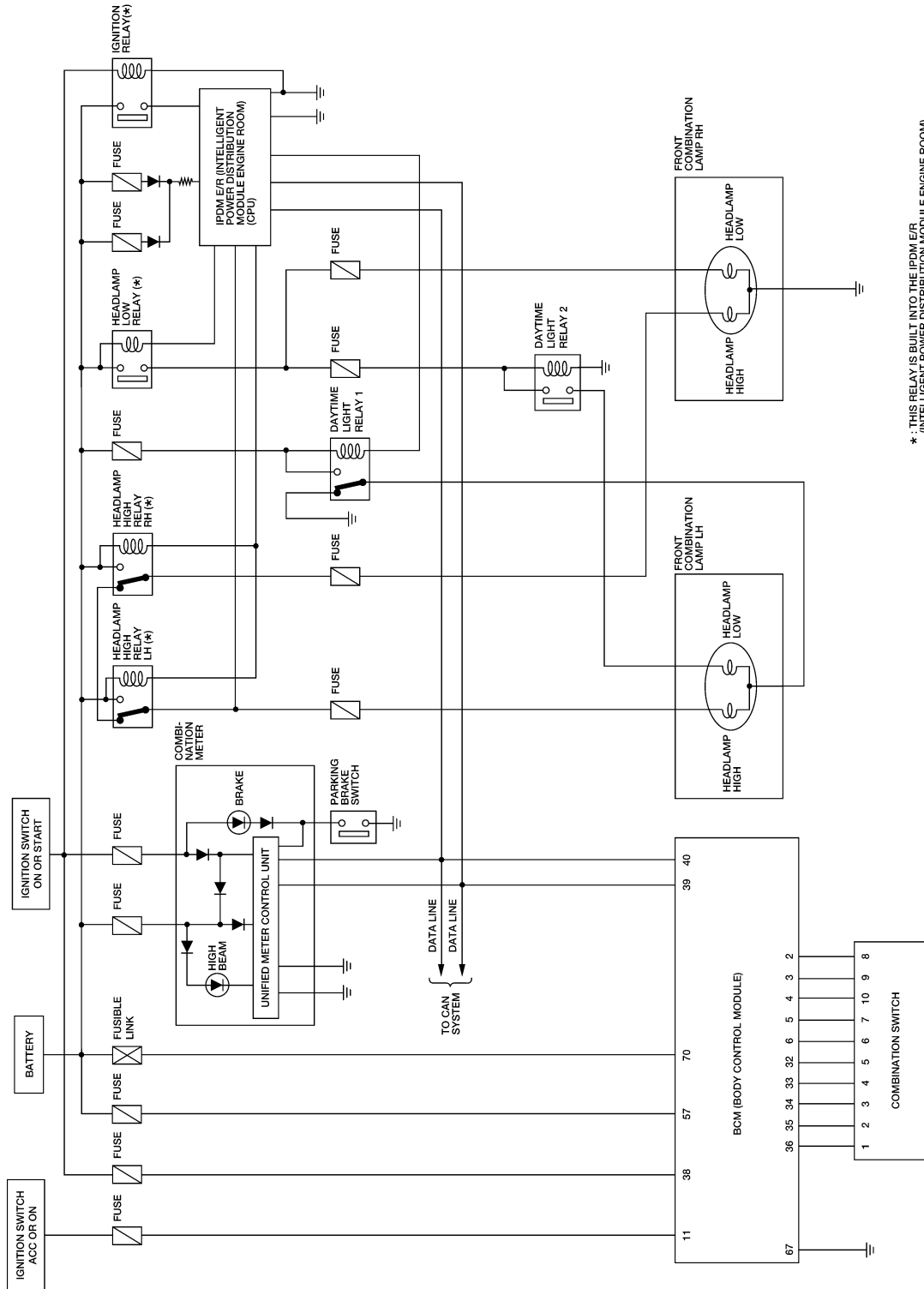

* : THIS RELAY IS BUILT INTO THE IPDM E/R (INTELLIGENT POWER DISTRIBUTION MODULE ENGINE ROOM)

BKWA0784E

HEADLAMP (FOR CANADA) - DAYTIME LIGHT SYSTEM -

< SERVICE INFORMATION >

Wiring Diagram - DTRL -

INFOID:000000004409113

LT-DTRL-01

— : DATA LINE

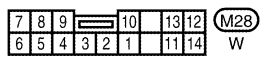
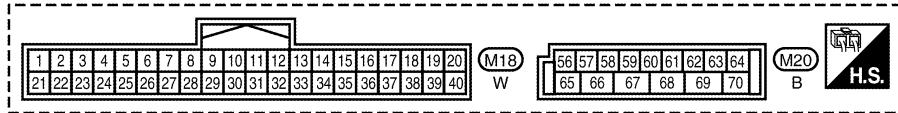
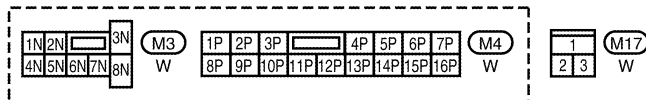
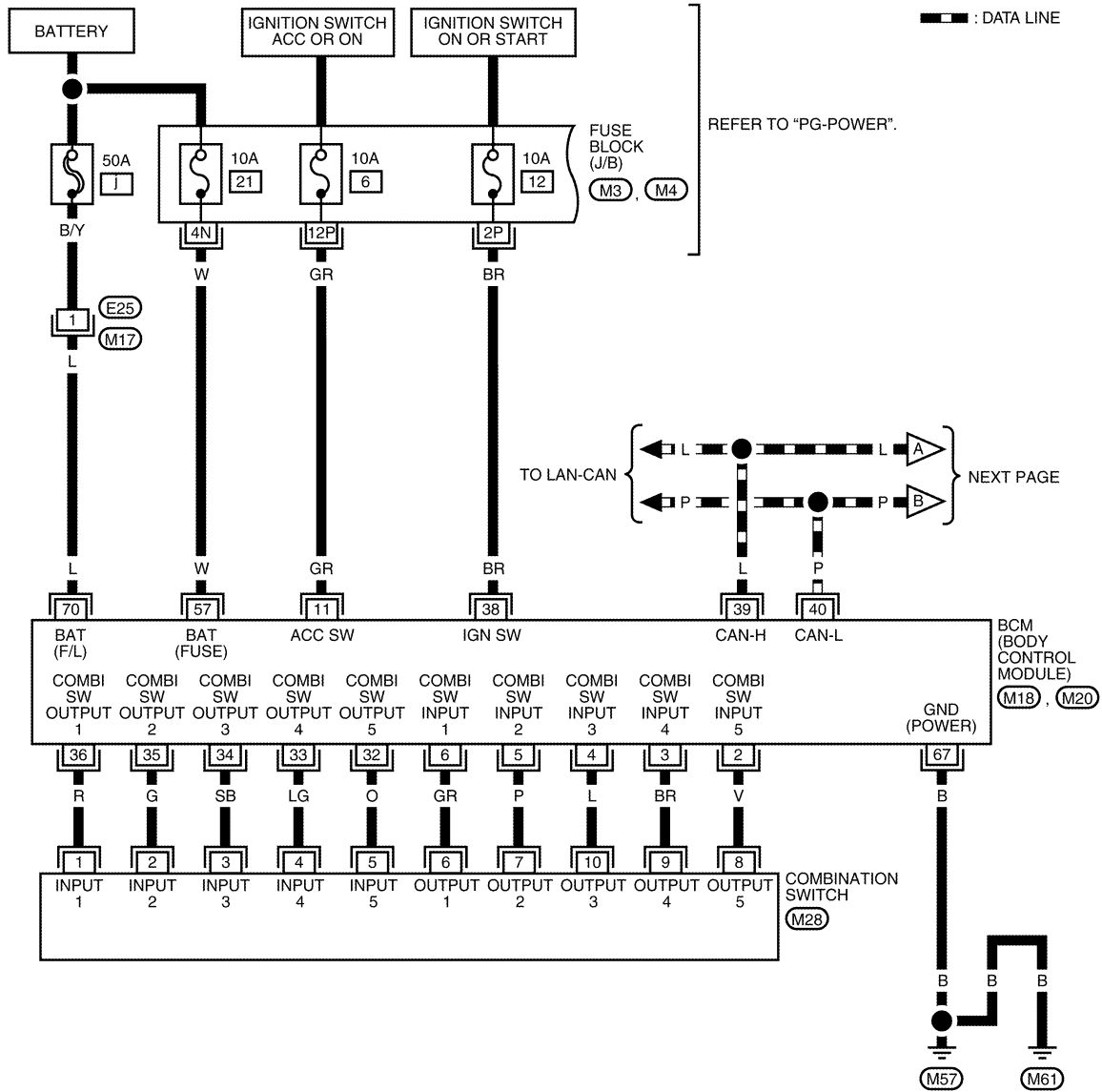

BKWA0785E

HEADLAMP (FOR CANADA) - DAYTIME LIGHT SYSTEM -

< SERVICE INFORMATION >

LT-DTRL-02

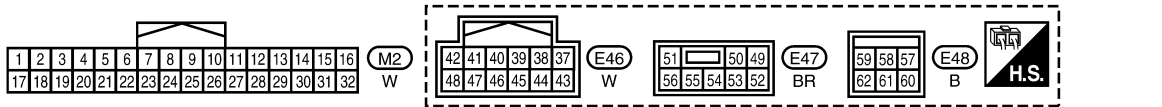
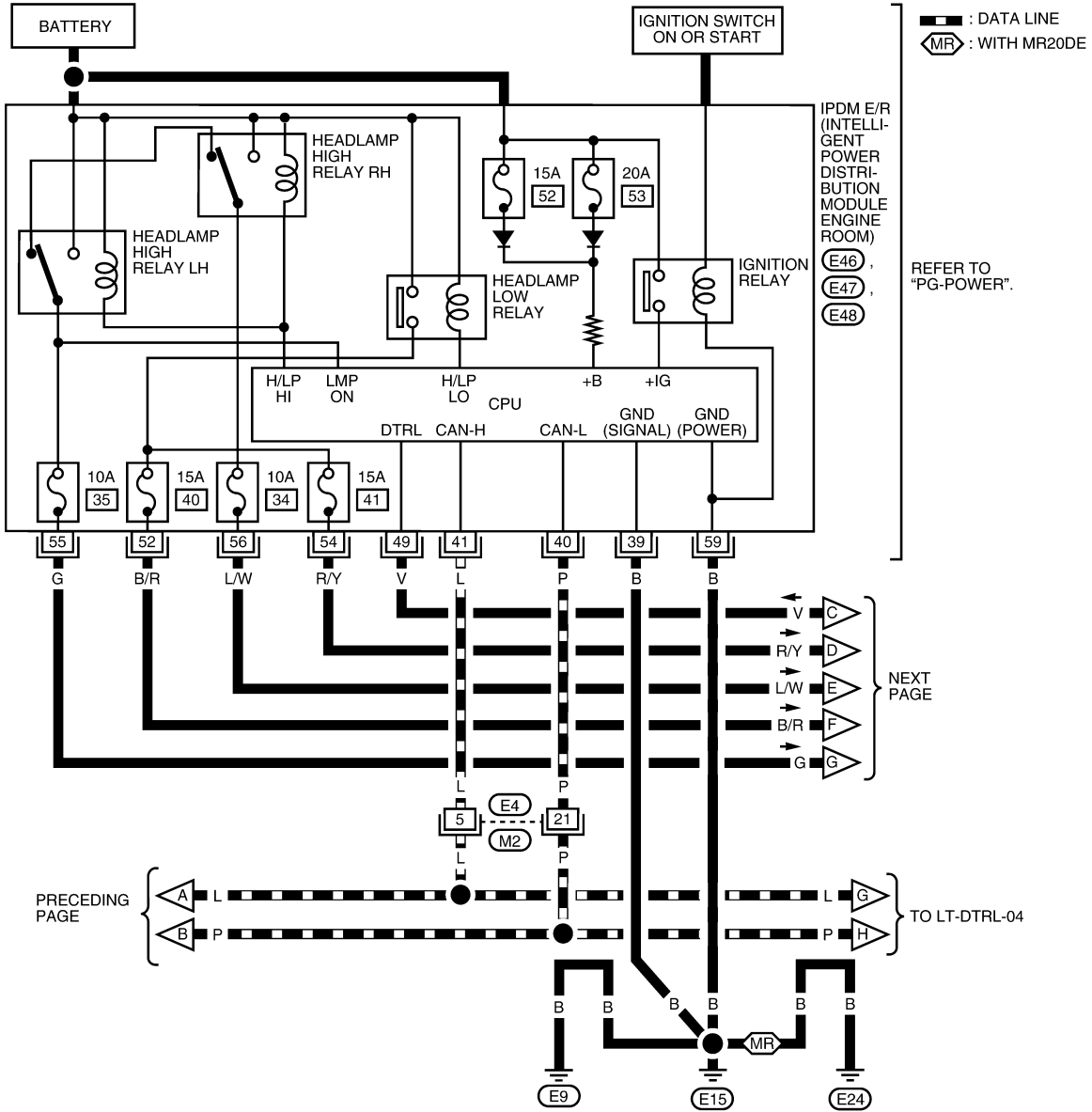

BKWA0834E

HEADLAMP (FOR CANADA) - DAYTIME LIGHT SYSTEM -

< SERVICE INFORMATION >

LT-DTRL-03

MR : WITH MR20DE

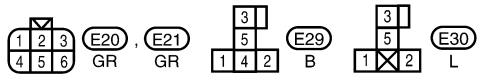
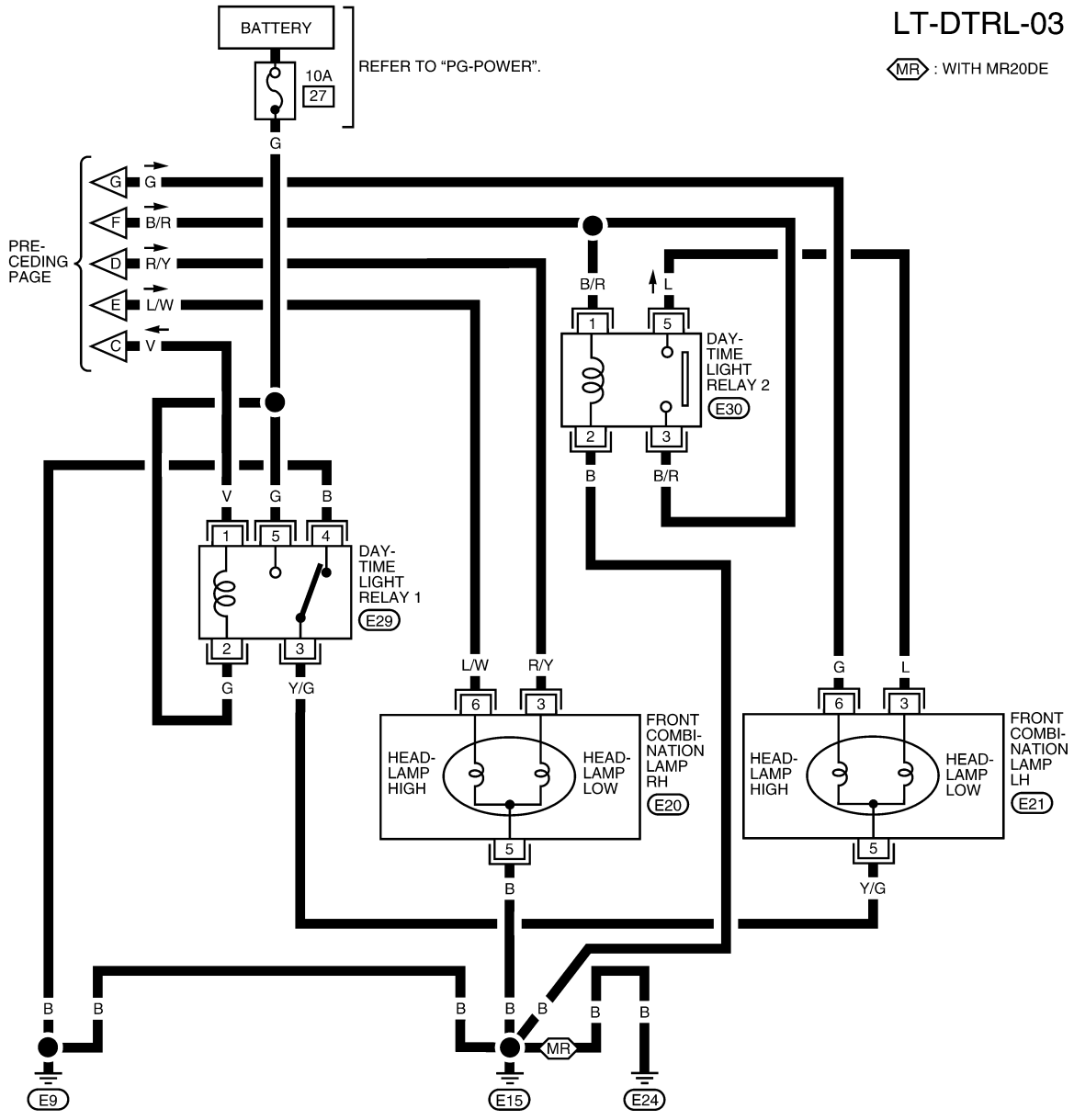

AWLWA0078GE

HEADLAMP (FOR CANADA) - DAYTIME LIGHT SYSTEM -

< SERVICE INFORMATION >

LT-DTRL-04

▬ : DATA LINE

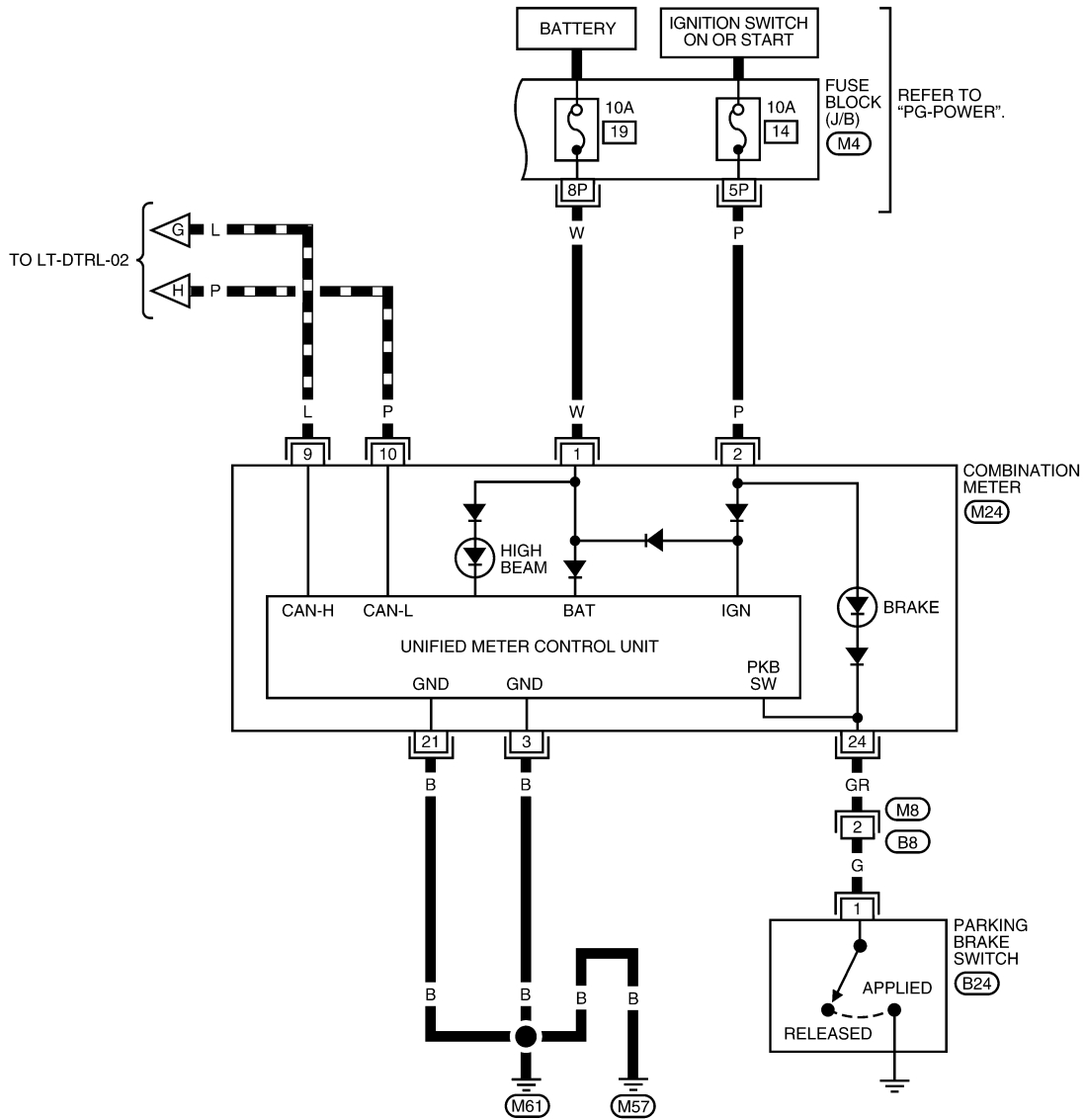

1P	2P	3P	4P	5P	6P	7P	(M4)	1	2	3	4	5	6	7	(M8)	20	19	18	17	16	15	14	13	12	11	10	9	8	7	6	5	4	3	2	1	(M24)																	
8P	9P	10P	11P	12P	13P	14P	15P	16P	W	8	9	10	11	12	13	14	15	16	17	18	19	20	31	32	33	34	35	36	37	38	39	40	21	22	23	24	25	26	27	28	29	30	31	32	33	34	35	36	37	38	39	40	W

(B24)
1
B

ABLWA0322GB

INFOID:000000004409114

Terminal and Reference Value for BCM

Refer to [BCS-11, "Terminal and Reference Value for BCM"](#).

Terminal and Reference Value for IPDM E/R

INFOID:000000004409115

Refer to [PG-24, "Terminal and Reference Value for IPDM E/R"](#).

HEADLAMP (FOR CANADA) - DAYTIME LIGHT SYSTEM -

< SERVICE INFORMATION >

How to Perform Trouble Diagnosis

INFOID:000000004409116

1. Confirm the symptom or customer complaint.
2. Understand operation, description and function description. Refer to [LT-25. "System Description"](#).
3. Perform the Preliminary Check. Refer to [LT-33. "Preliminary Check"](#).
4. Check symptom and repair or replace the cause of the malfunction.
5. Does the daytime light system operate normally? If YES, GO TO 6. If NO, GO TO 4.
6. Inspection end.

Preliminary Check

INFOID:000000004409117

CHECK BCM CONFIGURATION

1. CHECK BCM CONFIGURATION

Confirm BCM configuration for "DTRL" is set to "WITH". Refer to [BCS-17. "Configuration"](#).

OK or NG

- OK >> Continue preliminary check. Refer to [BCS-14. "BCM Power Supply and Ground Circuit Inspection"](#).
- NG >> Change BCM configuration for "DTRL" to "WITH". Refer to [BCS-17. "Configuration"](#).

CHECK POWER SUPPLY AND GROUND CIRCUIT FOR BCM

Refer to [BCS-14. "BCM Power Supply and Ground Circuit Inspection"](#).

CHECK POWER SUPPLY AND GROUND CIRCUIT FOR IPDM E/R

Refer to [PG-26. "IPDM E/R Power/Ground Circuit Inspection"](#).

CONSULT-III Function (BCM)

INFOID:000000004409118

Refer to [BCS-15. "CONSULT-III Function \(BCM\)"](#).

CONSULT-III Function (IPDM E/R)

INFOID:000000004409119

Refer to [PG-18. "CONSULT-III Function \(IPDM E/R\)"](#).

Daytime Light Control Does Not Operate Properly (High Beam Headlamps Operate Properly)

INFOID:000000004409120

1. CHECK DAYTIME LIGHT RELAY 1 FUSE

Inspect daytime light relay fuse 10A fuse (No. 27, located in the fuse and fusible link box).

OK or NG

- OK >> GO TO 2.
- NG >> Repair harness.

2. CHECK DAYTIME LIGHT RELAY 1 POWER SUPPLY CIRCUIT

1. Turn ignition switch OFF.
2. Remove daytime light relay 1.
3. Check voltage between daytime light relay 1 harness connector E29 terminals 2, 5 and ground.

2, 5 - Ground : Battery voltage should exist.

OK or NG

- OK >> GO TO 3.
- NG >> Repair harness or connector.

3. CHECK DAYTIME LIGHT RELAY 1

1. Apply battery voltage to daytime light relay 1 terminal 2 and supply ground to terminal 1.

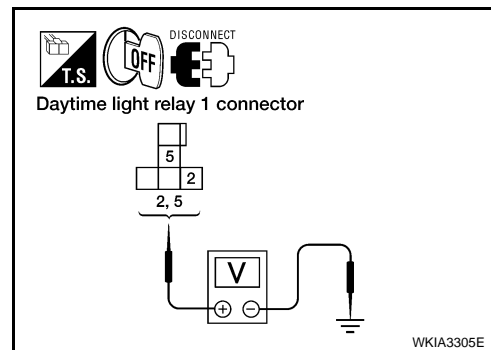

HEADLAMP (FOR CANADA) - DAYTIME LIGHT SYSTEM -

< SERVICE INFORMATION >

2. Check continuity between terminals 3 and 5.

3 - 5 : Continuity should exist.

OK or NG

- OK >> GO TO 4.
- NG >> Replace daytime light relay 1.

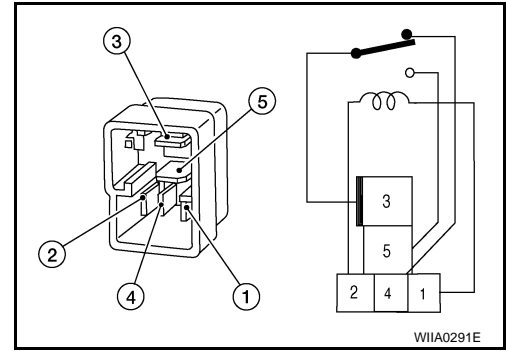

4. CHECK INPUT SIGNAL

1. Connect daytime light relay 1.
2. Apply parking brake and start engine. Headlamp switch OFF.
3. Select "IPDM E/R" on CONSULT-III. With DATA MONITOR, make sure "DTRL REQ" turns OFF-ON linked with operation of parking brake switch.

Parking brake ON : DTRL REQ OFF

Parking brake OFF : DTRL REQ ON

OK or NG

- OK >> GO TO 6.
- NG >> GO TO 5.

5. CHECKING CAN COMMUNICATIONS

Select "BCM" on CONSULT-III and perform self-diagnosis for BCM.

Displayed self-diagnosis results

- NO DTC>>Replace BCM. Refer to [BCS-17. "Removal and Installation of BCM"](#).
- CAN COMM CIRCUIT>> Check BCM CAN communication system. Refer to [LAN-15. "Trouble Diagnosis Flow Chart"](#).

6. CHECK DAYTIME LIGHT RELAY 1 CONTROL CIRCUIT

1. Turn ignition switch OFF.
2. Disconnect daytime light relay 1 connector E29.
3. Disconnect IPDM E/R connector E47.
4. Check continuity between IPDM E/R connector E47 (A) terminal 49 and daytime light relay 1 connector E29 (B) terminal 1.

A		B		Continuity
Connector	Terminal	Connector	Terminal	
E47	49	E29	1	Yes

OK or NG

- OK >> Replace the IPDM E/R. Refer to [PG-27. "Removal and Installation of IPDM E/R"](#).
- NG >> Repair harness or connector.

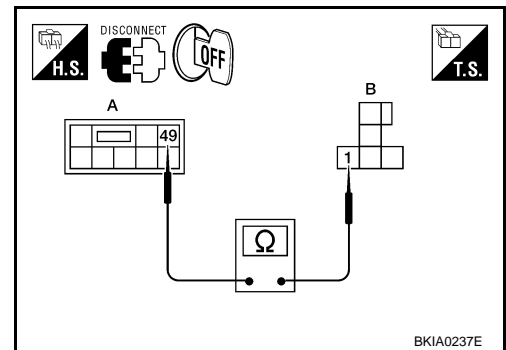

Aiming Adjustment

INFOID:000000004409121

The headlamp for Canada is the same as the headlamp for USA. Refer to [LT-21. "Aiming Adjustment"](#).

Bulb Replacement

INFOID:000000004409122

The headlamp for Canada is the same as the headlamp for USA. Refer to [LT-22. "Bulb Replacement"](#).

Removal and Installation

INFOID:000000004409123

The headlamp for Canada is the same as the headlamp for USA. Refer to [LT-23. "Removal and Installation"](#).

HEADLAMP (FOR CANADA) - DAYTIME LIGHT SYSTEM -

< SERVICE INFORMATION >

Disassembly and Assembly

INFOID:000000004409124

The headlamp for Canada is the same as the headlamp for USA. Refer to [LT-24, "Disassembly and Assembly"](#).

- A
- B
- C
- D
- E
- F
- G
- H
- I
- J
- LT**
- L
- M
- N
- O
- P

FRONT FOG LAMP

< SERVICE INFORMATION >

FRONT FOG LAMP

Component Parts and Harness Connector Location

INFOID:000000004409125

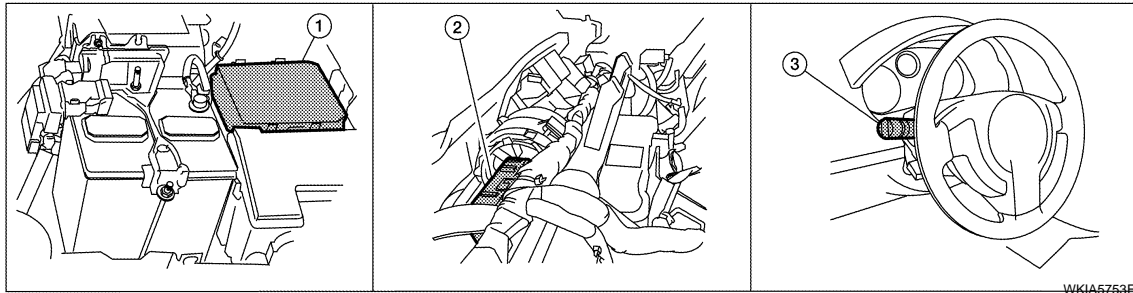

1. IPDM E/R E46, E47 and E48
2. BCM M18 and M20 (viewed with instrument panel removed)
3. Combination switch (lighting switch) M28

System Description

INFOID:000000004409126

The front fog lamps are controlled by lighting switch inputs to the BCM (body control module). The lighting switch must be in the 1ST or 2ND position with the high beams OFF before the BCM will request the IPDM E/R (intelligent power distribution module engine room) to turn the front fog lamps on. The BCM requests the front fog lamps over the CAN communication lines to the IPDM E/R. The CPU (central processing unit) of the IPDM E/R controls the front fog lamp relay coil ground. When energized, the relay directs power to the front fog lamps.

OUTLINE

Power is supplied at all times

- to front fog lamp relay (located in IPDM E/R),
- to ignition relay (located in IPDM E/R),
- through 15A fuse (No. 52, located in IPDM E/R) and
- through 20A fuse (No. 53, located in IPDM E/R)
- to CPU located in IPDM E/R,
- through 50A fusible link (letter j, located in the fuse and fusible link box)
- to BCM terminal 70,
- through 10A fuse [No. 21, located in fuse block (J/B)]
- to BCM terminal 57.

With the ignition switch in the ON or START position, power is supplied

- to ignition relay (located in IPDM E/R),
- through 10A fuse [No. 12, located in fuse block (J/B)]
- to BCM terminal 38.

With the ignition switch in the ACC or ON position, power is supplied

- through 10A fuse [No. 6, located in fuse block (J/B)]
- to BCM terminal 11.

Ground is supplied

- to BCM terminal 67
- through grounds M57 and M61,
- to IPDM E/R terminals 39 and 59
- through grounds E9, E15 (all models) and E24 (with MR20DE).

FOG LAMP OPERATION

The front fog lamp switch is built into the lighting switch. The lighting switch must be in 1ST position or 2ND position and front fog lamp switch must be in the ON position for front fog lamp operation. The fog lamp will not operate with the high beam headlamps ON.

When the front fog lamp switch is in the ON position, the BCM sends a request, via the CAN communication lines, to the CPU of the IPDM E/R to ground the coil side of the front fog lamp relay. The front fog lamp relay then directs power

- through 15A fuse (No. 56, located in IPDM E/R)
- through IPDM E/R terminal 50
- to front fog lamp LH terminal 1, and

FRONT FOG LAMP

< SERVICE INFORMATION >

- through IPDM E/R terminal 51
 - to front fog lamp RH terminal 1.
- Ground is supplied
- to front fog lamp LH and RH terminal 2,
 - through grounds E9, E15 (all models) and E24 (with MR20DE).
- With power and ground supplied, front fog lamps illuminate.

COMBINATION SWITCH READING FUNCTION

Refer to [LT-59. "Combination Switch Reading Function"](#).

CAN Communication System Description

INFOID:000000004409127

Refer to [LAN-6. "System Description"](#).

A
B
C
D
E
F
G
H
I
J
LT
L
M
N
O
P

FRONT FOG LAMP

< SERVICE INFORMATION >

Wiring Diagram - F/FOG -

INFOID:00000004409128

LT-F/FOG-01

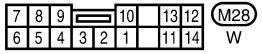
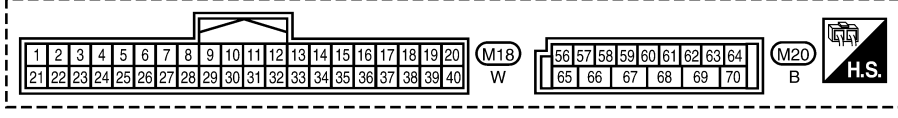
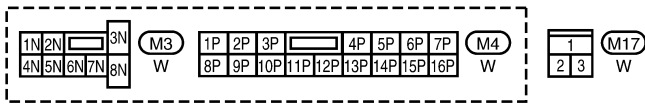
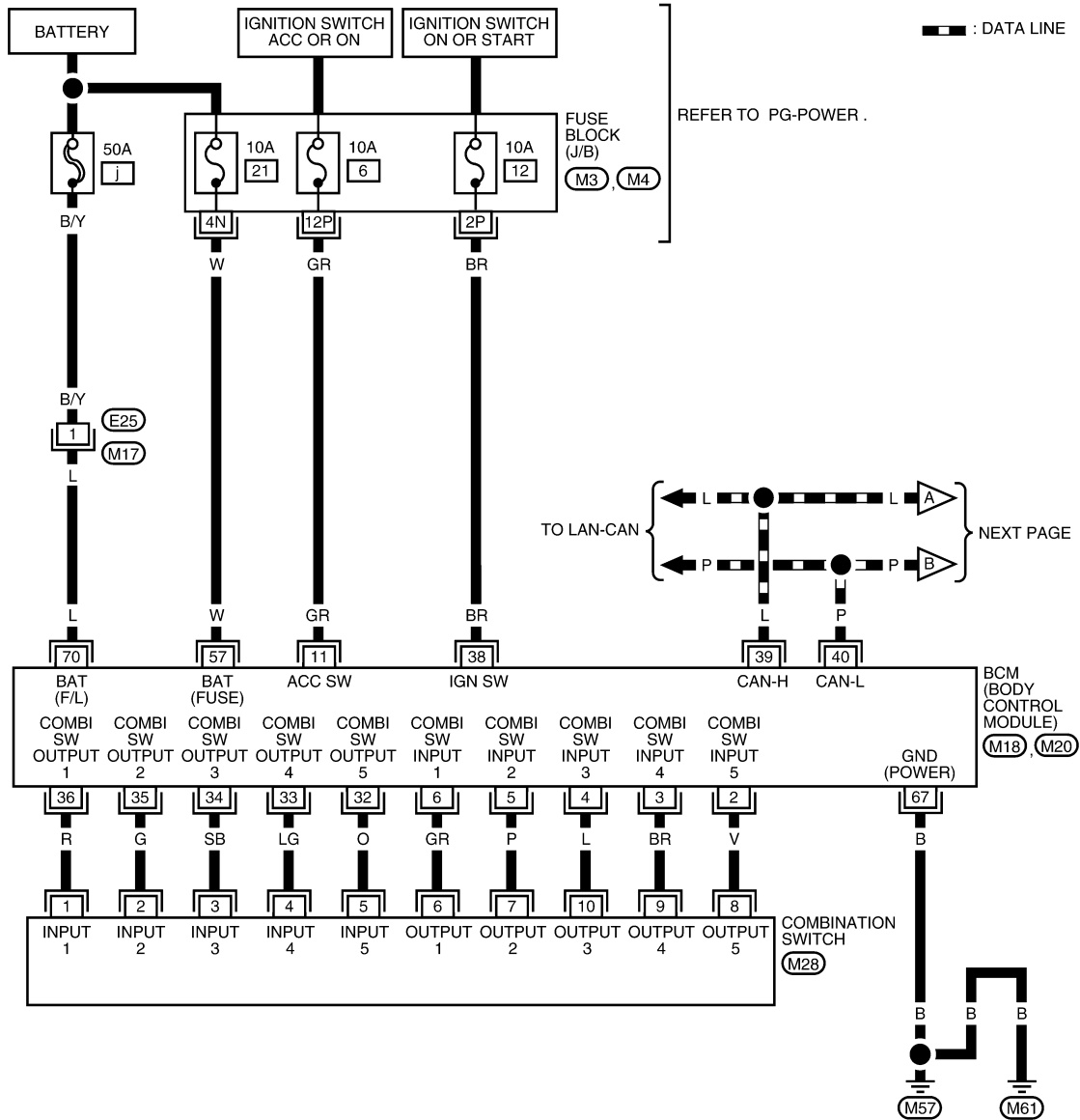

BKWA0789E

FRONT FOG LAMP

< SERVICE INFORMATION >

LT-F/FOG-02

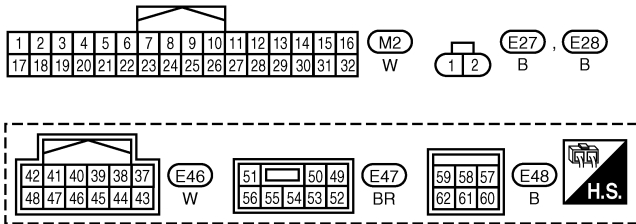
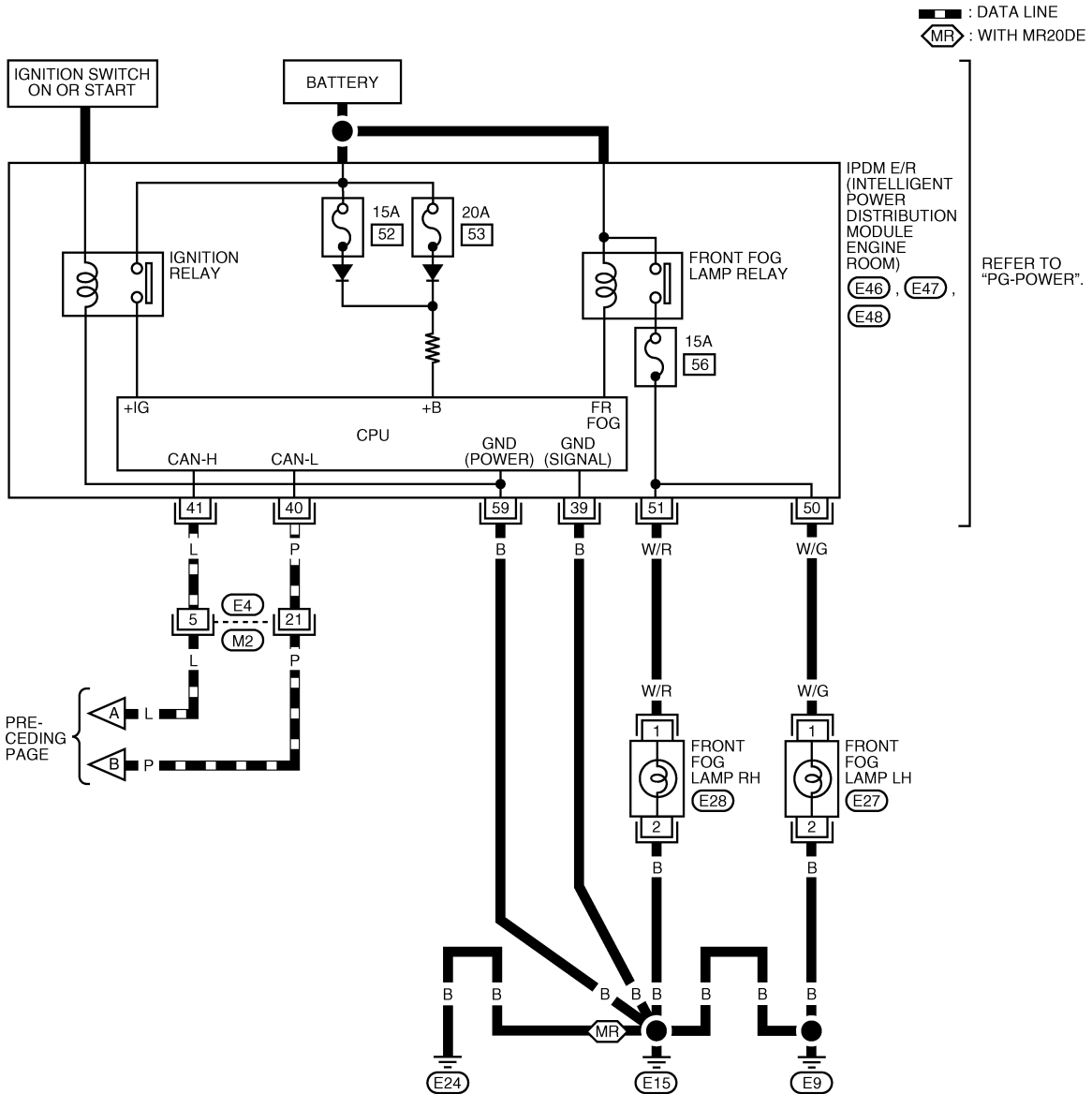

BKWA0836E

Terminal and Reference Value for BCM

Refer to [BCS-11, "Terminal and Reference Value for BCM"](#).

Terminal and Reference Value for IPDM E/R

Refer to [PG-24, "Terminal and Reference Value for IPDM E/R"](#).

INFOID:000000004409129

INFOID:000000004409130

FRONT FOG LAMP

< SERVICE INFORMATION >

How to Proceed with Trouble Diagnosis

INFOID:000000004409131

1. Confirm the symptom or customer complaint.
2. Understand operation description and function description. Refer to [LT-36, "System Description"](#).
3. Perform the Preliminary Check. Refer to [LT-40, "Preliminary Check"](#).
4. Check symptom and repair or replace the cause of the malfunction.
5. Do the front fog lamps operate normally? If YES, GO TO 6. If NO, GO TO 4.
6. Inspection end.

Preliminary Check

INFOID:000000004409132

CHECK POWER SUPPLY AND GROUND CIRCUIT FOR BCM

Refer to [BCS-14, "BCM Power Supply and Ground Circuit Inspection"](#).

CHECK POWER SUPPLY AND GROUND CIRCUIT FOR IPDM E/R

Refer to [PG-26, "IPDM E/R Power/Ground Circuit Inspection"](#).

CONSULT-III Function (BCM)

INFOID:000000004409133

Refer to [BCS-15, "CONSULT-III Function \(BCM\)"](#).

CONSULT-III Function (IPDM E/R)

INFOID:000000004409134

Refer to [PG-18, "CONSULT-III Function \(IPDM E/R\)"](#).

Front Fog lamps Do Not Illuminate (Both Sides)

INFOID:000000004409135

1. INSPECT FOG LAMP FUSE

Inspect fog lamp 15A fuse (No. 56, located in IPDM E/R).

OK or NG

- OK >> GO TO 2.
- NG >> Repair harness.

2. CHECK COMBINATION SWITCH INPUT SIGNAL

With CONSULT-III

1. Select "BCM" on CONSULT-III. Select "HEAD LAMP" on "SELECT TEST ITEM" screen.
2. Select "DATA MONITOR". Make sure that "FR FOG SW" turns ON-OFF linked with operation of fog lamp switch.

When fog lamp switch is ON : FR FOG SW ON

Without CONSULT-III

Refer to [LT-60, "Combination Switch Inspection"](#).

OK or NG

- OK >> GO TO 3.
- NG >> Check combination switch (lighting switch). Refer to [LT-60, "Combination Switch Inspection"](#).

3. FOG LAMP ACTIVE TEST

With CONSULT-III

1. Select "IPDM E/R" on CONSULT-III. Select "ACTIVE TEST".
2. Select "LAMPS" on "SELECT TEST ITEM" screen.
3. Touch "FOG" screen.
4. Make sure front fog lamp operates.

Front fog lamp should operate.

Without CONSULT-III

1. Start auto active test. Refer to [PG-20, "Auto Active Test"](#).
2. Make sure front fog lamp operates.

FRONT FOG LAMP

< SERVICE INFORMATION >

Front fog lamp should operate.

OK or NG

- OK >> GO TO 4.
- NG >> GO TO 5.

4.CHECK IPDM E/R

1. Select "IPDM E/R" on CONSULT-III. Select "DATA MONITOR".
2. Make sure "FR FOG REQ" turns ON when front fog lamp switch is in ON position.

When front fog lamp switch : FR FOG REQ ON
is ON position

OK or NG

- OK >> Replace IPDM E/R. Refer to [PG-27. "Removal and Installation of IPDM E/R"](#) .
- NG >> Replace BCM. Refer to [BCS-17. "Removal and Installation of BCM"](#) .

5.CHECK FOG LAMP INPUT SIGNAL

Ⓜ With CONSULT-III

1. Turn ignition switch OFF.
2. Disconnect front fog lamp connector.
3. Turn ignition switch ON.
4. Select "IPDM E/R" on CONSULT-III, and select "ACTIVE TEST".
5. Select "LAMPS" on "SELECT TEST ITEM" screen.
6. Touch "FOG" screen.
7. When front fog lamp relay is operating, check voltage between front fog lamp harness connector and ground.

(+)		Terminal	(-)	Voltage
Front fog lamp connector				
RH	E28	1	Ground	Battery voltage
LH	E27			

ⓧ Without CONSULT-III

1. Turn ignition switch OFF.
2. Disconnect front fog lamp connector.
3. Turn ignition switch ON.
4. Start auto active test. Refer to [PG-20. "Auto Active Test"](#) .
5. When front fog lamp relay is operating, check voltage between front fog lamp harness connector and ground.

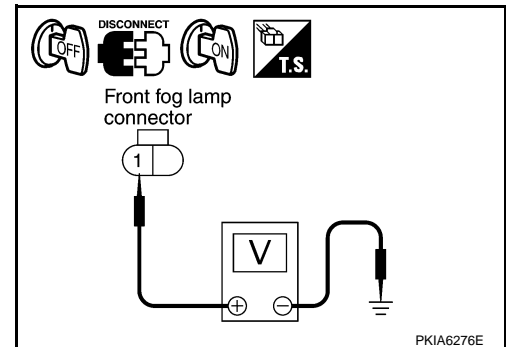

(+)		Terminal	(-)	Voltage
Front fog lamp connector				
RH	E28	1	Ground	Battery voltage
LH	E27			

OK or NG

- OK >> GO TO 7.
- NG >> GO TO 6.

6.CHECK FOG LAMP CIRCUIT

1. Turn ignition switch OFF.
2. Disconnect IPDM E/R connector.

FRONT FOG LAMP

< SERVICE INFORMATION >

- Check continuity between IPDM E/R harness connector (A) and front fog lamp harness connector (B).

Circuit	A		B		Continuity
	Connector	Terminal	Connector	Terminal	
RH	E47	51	E28	1	Yes
LH		50	E27		

OK or NG

OK >> Replace IPDM E/R. Refer to [PG-27. "Removal and Installation of IPDM E/R"](#).

NG >> Repair harness or connector.

7. CHECK FOG LAMP GROUND

- Check continuity between front fog lamp harness connector and ground.

Front fog lamp connector		Terminal	Ground	Continuity
RH	E28	2		Yes
LH	E27			

OK or NG

OK >> Check front fog lamp bulbs.

NG >> Repair harness or connector.

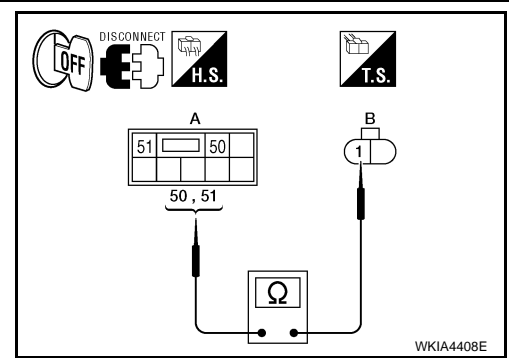

WKIA4408E

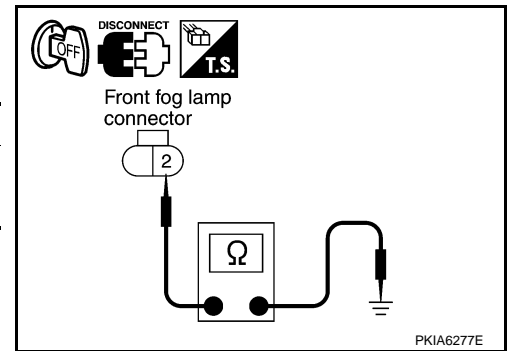

PKIA6277E

Front Fog Lamp Does Not Illuminate (One Side)

INFOID:000000004409136

1. CHECK BULB

Check bulb of lamp which does not illuminate.

OK or NG

OK >> GO TO 2.

NG >> Replace front fog lamp bulb. Refer to [LT-43. "Bulb Replacement"](#).

2. CHECK FOG LAMP CIRCUIT

- Turn ignition switch OFF.
- Disconnect IPDM E/R connector and front fog lamp connector.
- Check continuity between IPDM E/R harness connector (A) and front fog lamp harness connector (B).

Circuit	A		B		Continuity
	Connector	Terminal	Connector	Terminal	
RH	E47	51	E28	1	Yes
LH		50	E27		

OK or NG

OK >> GO TO 3.

NG >> Repair harness or connector.

3. CHECK FOG LAMP GROUND

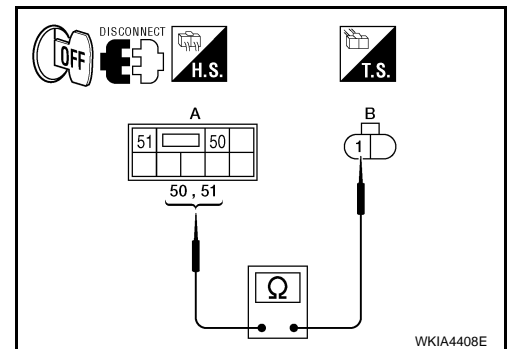

WKIA4408E

FRONT FOG LAMP

< SERVICE INFORMATION >

Check continuity between front fog lamp harness connector and ground.

Front fog lamp connector		Terminal	Ground	Continuity
RH	E28	2		Ground
LH	E27			

OK or NG

- OK >> Replace IPDM E/R. Refer to [PG-27, "Removal and Installation of IPDM E/R"](#).
- NG >> Repair harness or connector.

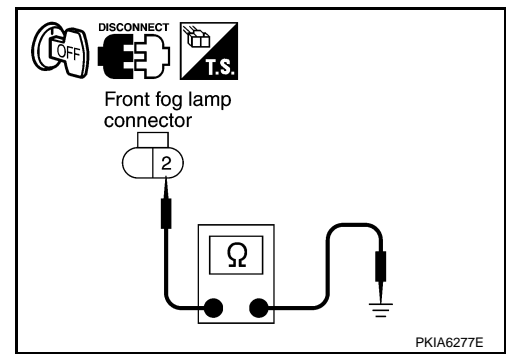

INFOID:000000004409137

Aiming Adjustment

The front fog lamp is a semi-sealed beam type which uses a replaceable halogen bulb. Before performing aiming adjustment, make sure of the following.

- Keep all tires inflated to correct pressure.
- Place vehicle on level surface.
- Set that there is no-load in vehicle other than the driver (or equivalent weight placed in driver's position). Coolant, engine oil filled up to correct level and full fuel tank.

Adjust aiming in the vertical direction by turning the adjusting screw (A).

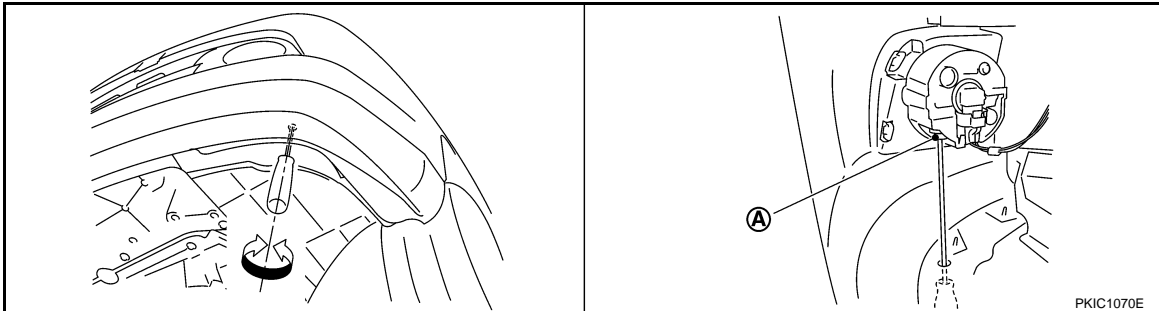

1. Set the distance (D) between the screen and the center of front fog lamp lens as shown.
2. Turn front fog lamps to ON.
3. Adjust front fog lamps using adjusting screw so that the top edge of the high intensity zone (C) is as shown.

Vertical distance from horizontal/vertical center point of fog lamp on screen to top edge of high intensity zone (A)	100 mm (4 in)
Horizontal/vertical center point of fog lamp	(B)
Fog lamp high intensity zone	(C)
Distance from fog lamp to screen (D)	7.62 mm (25 ft)

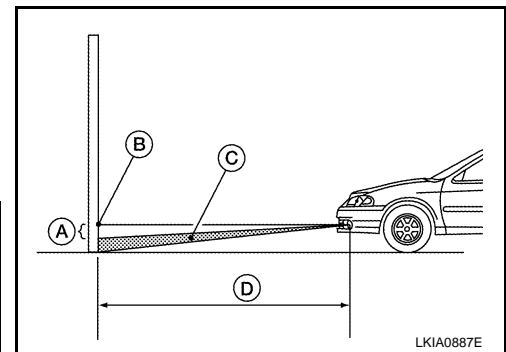

NOTE:

When performing adjustment, if necessary, cover the headlamps and opposite front fog lamp.

Bulb Replacement

INFOID:000000004409138

1. Turn lighting switch OFF.
2. Position back the front fender protector. Refer to [EI-22, "Removal and Installation"](#).

FRONT FOG LAMP

< SERVICE INFORMATION >

3. Disconnect front fog lamp connector (1).
4. Turn bulb socket (2) counterclockwise unlock and remove it.
5. Remove bulb from its socket.

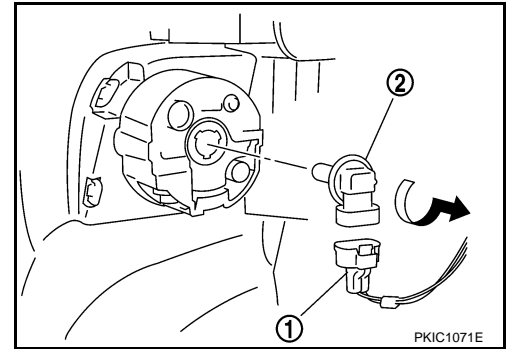

Removal and Installation, All Except SE-R

INFOID:000000004409139

REMOVAL

1. Remove the fender protector. Refer to [EI-22](#).
2. Disconnect the front fog lamp connector (3) from the fog lamp bulb (1).
3. Remove the front fog lamp screws (A) and remove the front fog lamp (2).
 - As necessary, remove the two staples attaching the base of the fog lamp (2) and discard the staples.

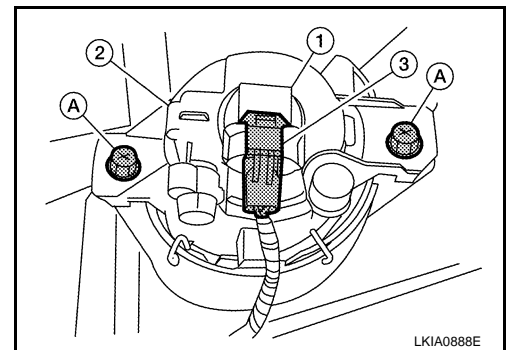

INSTALLATION

Installation is in the reverse order of removal.

Removal and Installation, SE-R

INFOID:000000004409140

REMOVAL

1. Disconnect the front fog lamp connector (1) from the fog lamp bulb (2).
2. Remove the front fog lamp screws (A) and remove the front fog lamp (3).

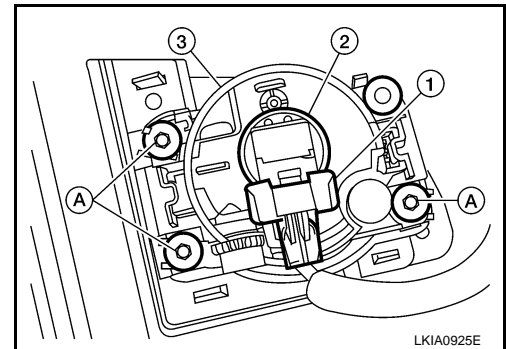

INSTALLATION

Installation is in the reverse order of removal.

TURN SIGNAL AND HAZARD WARNING LAMPS

< SERVICE INFORMATION >

TURN SIGNAL AND HAZARD WARNING LAMPS

Component Parts and Harness Connector Location

INFOID:000000004409141

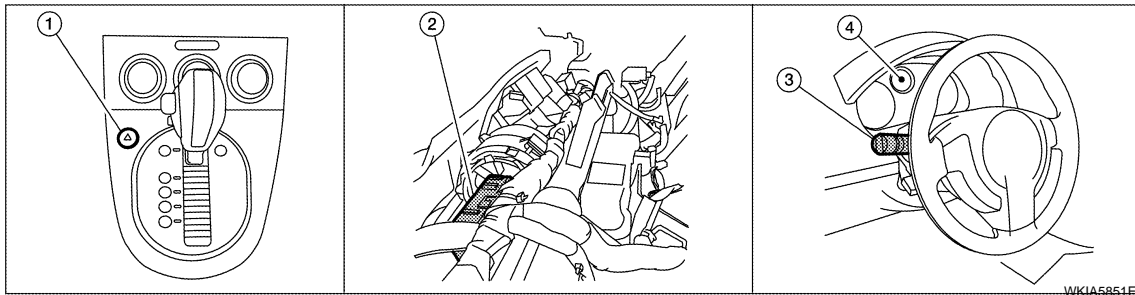

1. Hazard switch M102
2. BCM M18 and M20 (view with instrument panel removed)
3. Combination switch (lighting switch) M28
4. Combination meter M24

System Description

INFOID:000000004409142

TURN SIGNAL OPERATION

Power is supplied at all times

- through 50A fusible link (letter j, located in the fuse and fusible link box)
- to BCM (body control module) terminal 70,
- through 10A fuse [No. 21, located in the fuse block (J/B)]
- to BCM terminal 57,
- through 10A fuse [No. 19, located in the fuse block (J/B)]
- to combination meter terminal 1.

With the ignition switch in the ON or START position, power is supplied

- through 10A fuse [No. 12, located in fuse block (J/B)]
- to BCM terminal 38,
- through 10A fuse [No. 14, located in fuse block (J/B)]
- to combination meter terminal 2.

With the ignition switch in the ACC or ON position, power is supplied

- through 10A fuse [No. 6, located in the fuse block (J/B)]
- to BCM terminal 11.

Ground is supplied

- to BCM terminal 67 and
- to combination meter terminals 3 and 21
- through grounds M57 and M61.

LH Turn Signal Lamp

When the turn signal switch is moved to the left turn position, the BCM receives an input signal requesting left turn signals to flash. The BCM then supplies power

- through BCM terminal 60
- to front combination lamp LH terminal 4 and
- to rear combination lamp LH terminal 6.

Ground is supplied

- to front combination lamp LH terminal 2
- through grounds E9, E15 (all models) and E24 (with MR20DE),
- to rear combination lamp LH terminal 4
- through grounds B7 and B19.

The BCM also sends a request, via the CAN communication lines, to the combination meter to flash the left turn signal indicator. The unified meter control unit in the combination meter supplies ground to the left turn signal indicator lamp and activates the audible turn signal indicator.

With power, ground and input supplied, the BCM controls the flashing of the turn signal lamps.

RH Turn Signal Lamp

TURN SIGNAL AND HAZARD WARNING LAMPS

< SERVICE INFORMATION >

When turn signal switch is moved to the right turn position, the BCM receives an input signal requesting right turn signals to flash. The BCM then supplies power

- through BCM terminal 61
- to front combination lamp RH terminal 4 and
- to rear combination lamp RH terminal 6.

Ground is supplied

- to front combination lamp RH terminal 2
- through grounds E9, E15 (all models) and E24 (with MR20DE),
- to rear combination lamp RH terminal 4
- through grounds B7 and B19.

The BCM also sends a request, via the CAN communication lines, to the combination meter to flash the right turn signal indicator. The unified meter control unit in the combination meter supplies ground to the right turn signal indicator lamp and activates the audible turn signal indicator.

With power, ground and input supplied, the BCM controls the flashing of the turn signal lamps.

HAZARD LAMP OPERATION

Power is supplied at all times

- through 50A fusible link (letter j, located in fuse, fusible link and relay box)
- to BCM terminal 70,
- through 10A fuse [No. 21, located in fuse block (J/B)]
- to BCM terminal 57,
- through 10A fuse [No. 19, located in fuse block (J/B)]
- to combination meter terminal 1.

Ground is supplied

- to hazard switch terminal 1,
- to BCM terminal 67, and
- to combination meter terminals 3 and 21
- through grounds M57 and M61.

When hazard switch is depressed, ground is supplied

- through hazard switch terminal 2
- to BCM terminal 29.

BCM then supplies power

- to front combination lamp LH terminal 4 and
- to rear combination lamp LH terminal 6
- through BCM terminal 60,
- to front combination lamp RH terminal 4 and
- to rear combination lamp RH terminal 6
- through BCM terminal 61.

Ground is supplied

- to front combination lamp LH and RH terminal 2
- through grounds E9, E15 (all models) and E24 (with MR20DE),
- to rear combination lamp LH and RH terminal 4
- through grounds B7 and B19.

The BCM also supplies input to combination meter across the CAN communication lines. This input is processed by unified meter control unit in combination meter, which in turn supplies ground to the left and right turn signal indicator lamps.

With power and input supplied, BCM controls flashing of hazard warning lamps.

REMOTE KEYLESS ENTRY SYSTEM OPERATION

Power is supplied at all times

- through 50A fusible link (letter j, located in fuse, fusible link and relay box)
- to BCM terminal 70,
- through 10A fuse [No. 19, located in fuse block (J/B)]
- to combination meter terminal 1.

Ground is supplied

- to BCM terminal 67 and
- to combination meter terminals 3 and 21
- through grounds M57 and M61.

When the remote keyless entry system is triggered by input from the keyfob, the BCM supplies power

- through BCM terminal 60
- to front combination lamp LH terminal 4 and
- to rear combination lamp LH terminal 6,

TURN SIGNAL AND HAZARD WARNING LAMPS

< SERVICE INFORMATION >

- through BCM terminal 61
- to front turn signal lamp RH terminal 4 and
- to rear combination lamp RH terminal 6.

Ground is supplied

- to front combination lamp LH and RH terminal 2
- through grounds E9, E15 (all models) and E24 (with MR20DE),
- to rear combination lamp LH and RH terminal 4
- through grounds B7 and B19.

The BCM also supplies input to combination meter via the CAN communication lines. This input is processed by the unified meter control unit in combination meter, which in turn supplies ground to the left and right turn signal indicator lamps.

With power and ground supplied, BCM controls flashing of hazard warning lamps when keyfob is used to activate remote keyless entry system.

COMBINATION SWITCH READING FUNCTION

Refer to [LT-59, "Combination Switch Reading Function"](#).

CAN Communication System Description

INFOID:000000004409143

Refer to [LAN-6, "System Description"](#).

A
B
C
D
E
F
G
H
I
J
L
M
N
O
P

LT

TURN SIGNAL AND HAZARD WARNING LAMPS

< SERVICE INFORMATION >

Schematic

INFOID:000000004409144

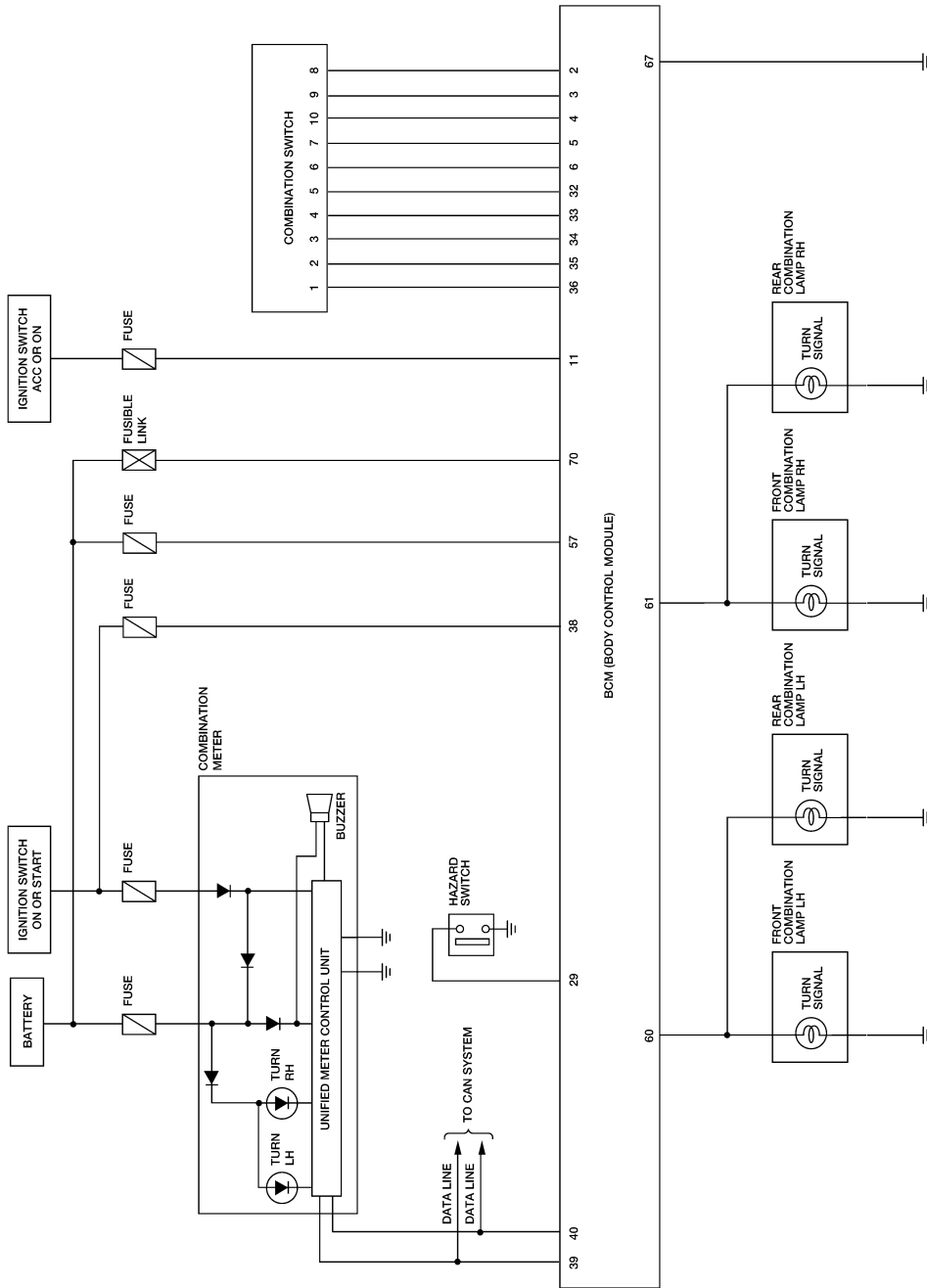

BKWA0791E

TURN SIGNAL AND HAZARD WARNING LAMPS

< SERVICE INFORMATION >

Wiring Diagram - TURN -

INFOID:000000004409145

LT-TURN-01

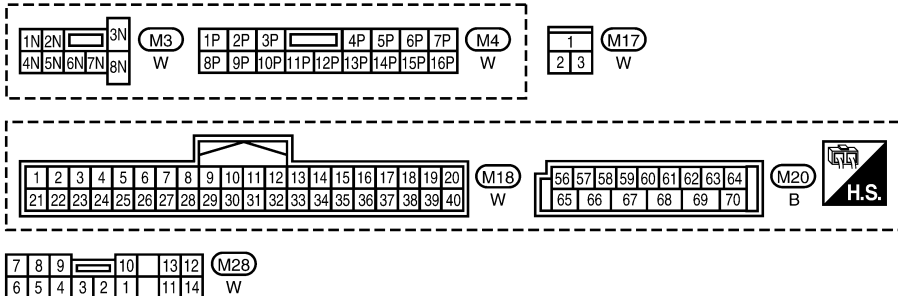
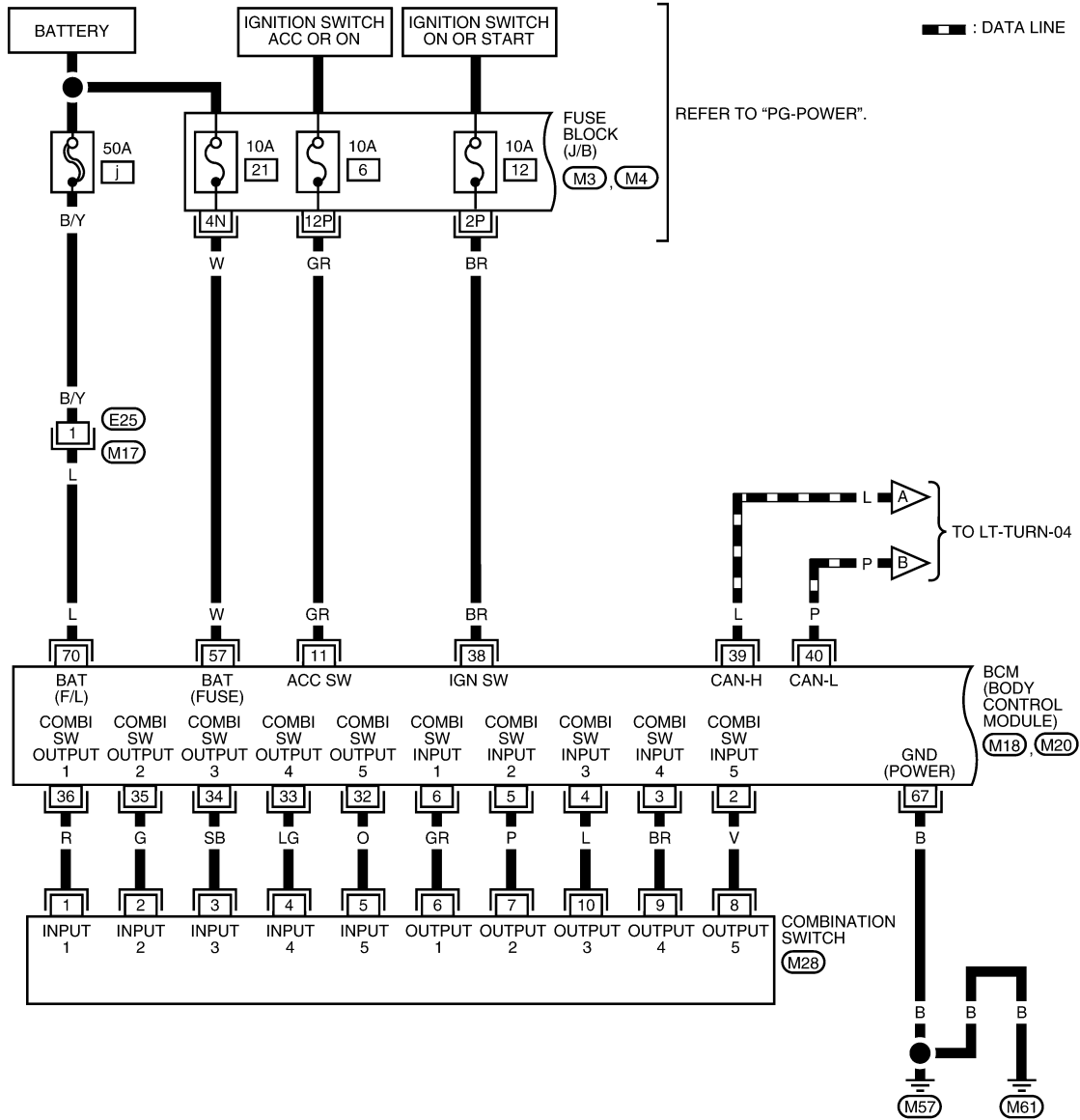

BKWA0792E

TURN SIGNAL AND HAZARD WARNING LAMPS

< SERVICE INFORMATION >

LT-TURN-02

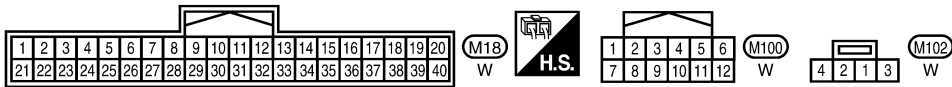
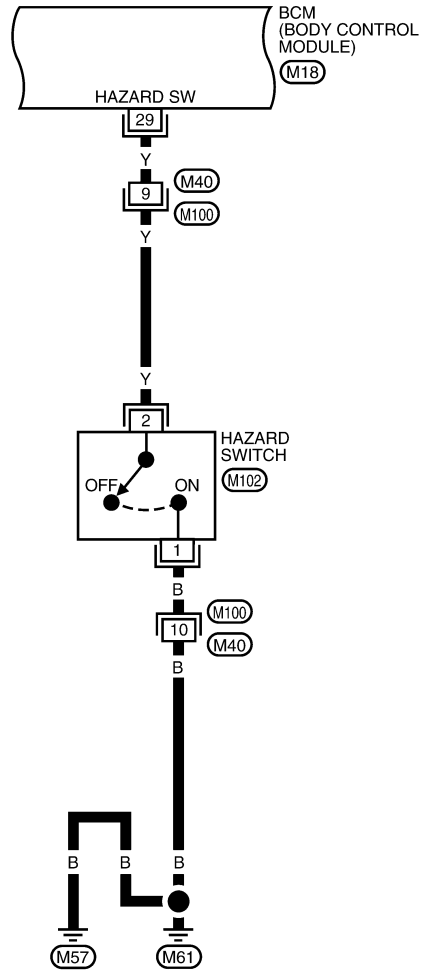

BKWA0793E

TURN SIGNAL AND HAZARD WARNING LAMPS

< SERVICE INFORMATION >

LT-TURN-03

MR : WITH MR20DE

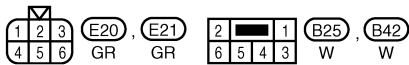
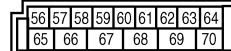
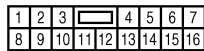
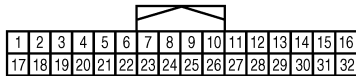
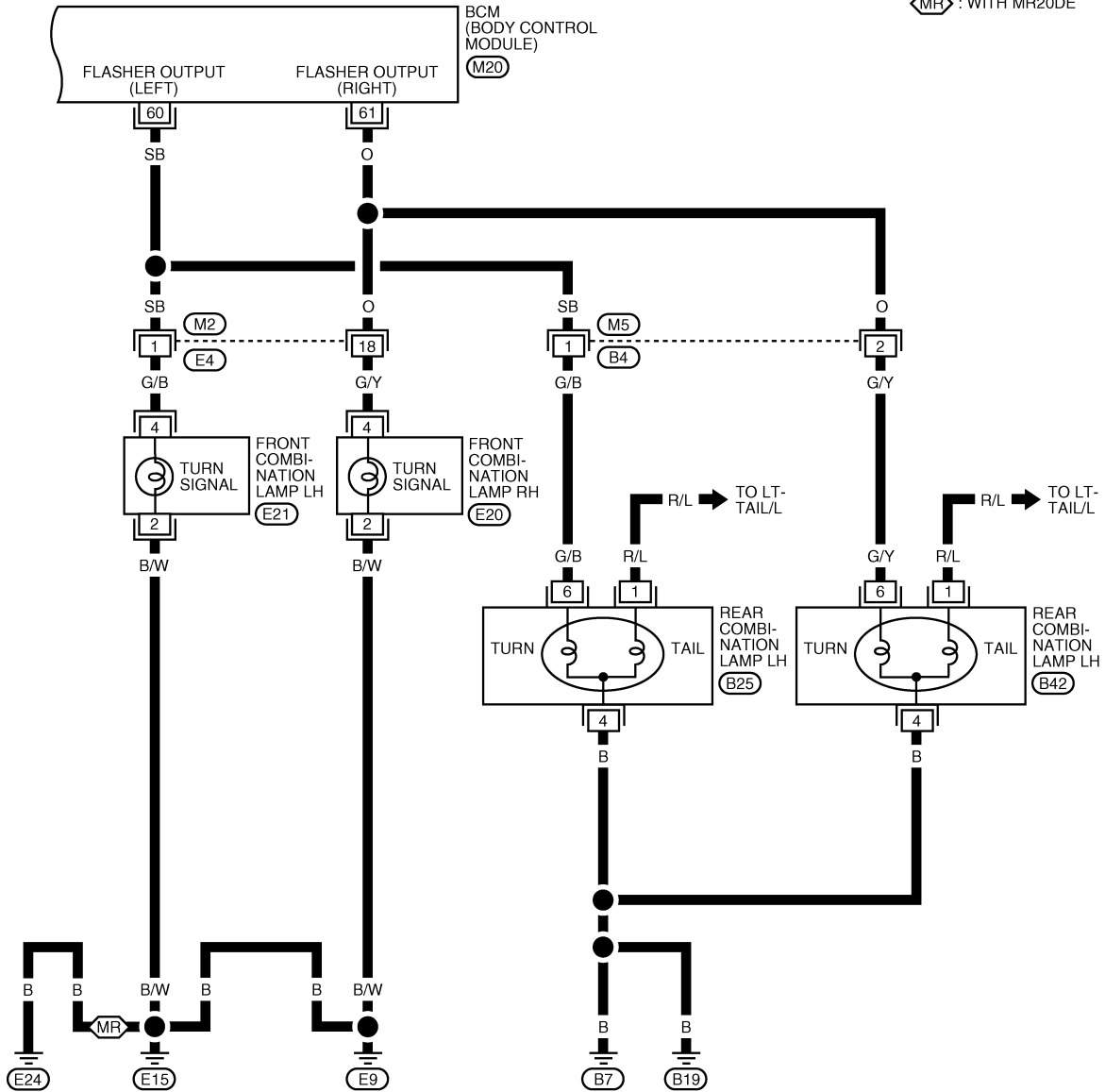

BKWA0837E

TURN SIGNAL AND HAZARD WARNING LAMPS

< SERVICE INFORMATION >

LT-TURN-04

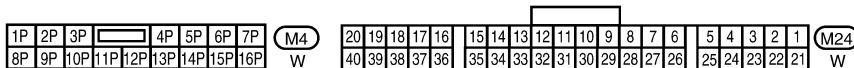
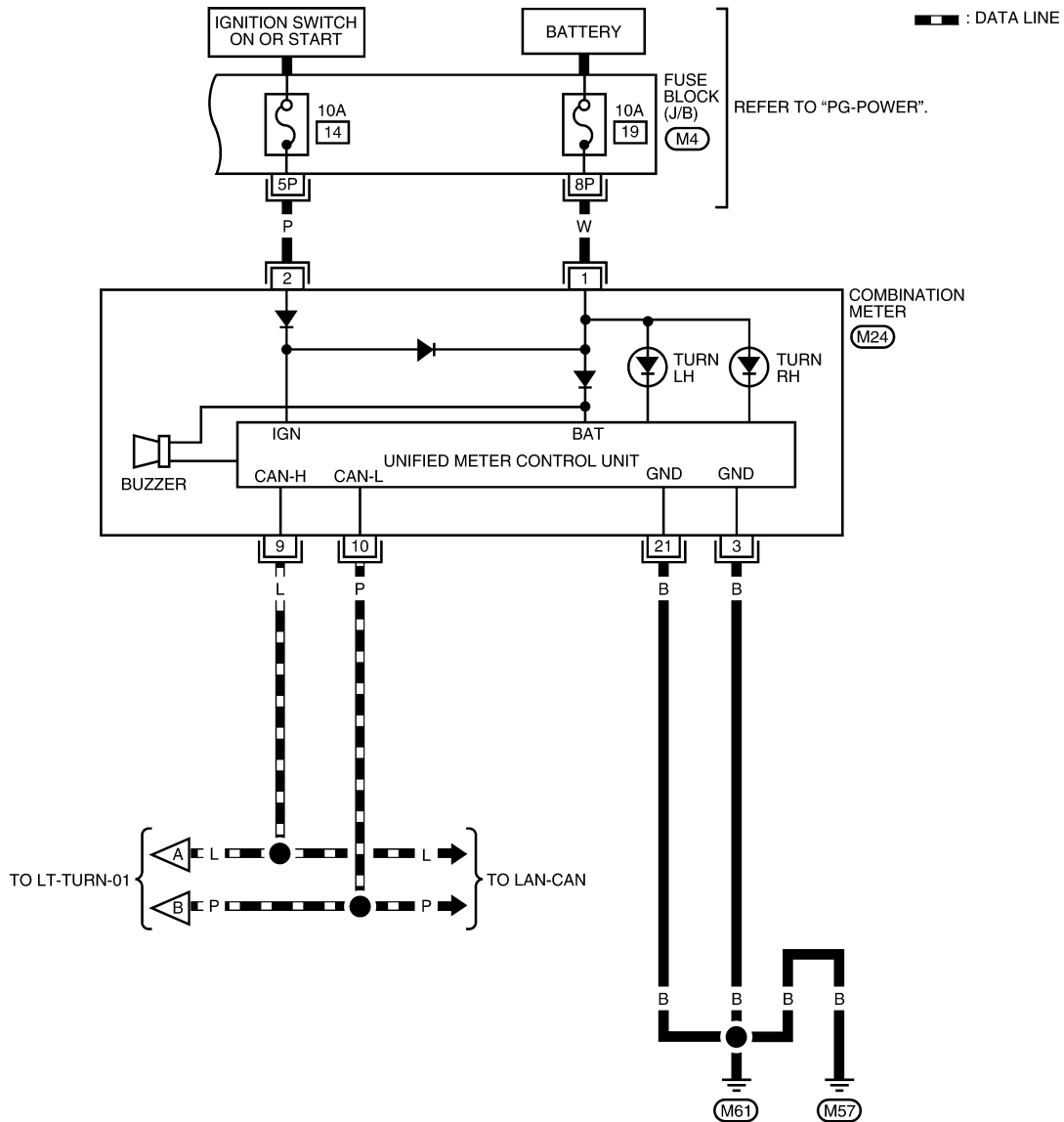

BKWA0795E

INFOID:000000004409146

Terminal and Reference Value for BCM

Refer to [BCS-11, "Terminal and Reference Value for BCM"](#).

How to Proceed with Trouble Diagnosis

INFOID:000000004409147

1. Confirm the symptom or customer complaint.
2. Understand operation description and function description. Refer to [LT-45, "System Description"](#).

TURN SIGNAL AND HAZARD WARNING LAMPS

< SERVICE INFORMATION >

3. Perform the preliminary check. Refer to [LT-53. "Preliminary Check"](#).
4. Check symptom and repair or replace the cause of the malfunction.
5. Do turn signal and hazard warning lamps operate normally? If YES, GO TO 6. If NO, GO TO 4.
6. INSPECTION END

Preliminary Check

INFOID:000000004409148

CHECK POWER SUPPLY AND GROUND CIRCUIT FOR BCM

Refer to [BCS-14. "BCM Power Supply and Ground Circuit Inspection"](#).

CONSULT-III Function (BCM)

INFOID:000000004409149

Refer to [BCS-15. "CONSULT-III Function \(BCM\)"](#).

Turn Signals Do Not Operate

INFOID:000000004409150

1. CHECK COMBINATION SWITCH INPUT SIGNAL

 With CONSULT-III

1. Select "BCM" on CONSULT-III. Select "FLASHER" on "SELECT TEST ITEM" screen.
2. Select "DATA MONITOR". Make sure that "TURN SIGNAL R" and "TURN SIGNAL L" turn ON-OFF linked with operation of lighting switch.

**When turn signal switch is : TURN SIGNAL R ON
right position**

**When turn signal switch is : TURN SIGNAL L ON
left position**

 Without CONSULT-III

Refer to [LT-60. "Combination Switch Inspection"](#).

OK or NG

- OK >> Replace the BCM. Refer to [BCS-17. "Removal and Installation of BCM"](#).
- NG >> Check combination switch (lighting switch). Refer to [LT-60. "Combination Switch Inspection"](#).

Front Turn Signal Lamp Does Not Operate

INFOID:000000004409151

1. CHECK BULB

Verify the bulb standard of each turn signal lamp is correct. Refer to [LT-106. "Exterior Lamp"](#).

OK or NG

- OK >> GO TO 2.
- NG >> Replace turn signal lamp bulb. Refer to [LT-56. "Bulb Replacement for Front Turn Signal Lamp"](#).

2. CHECK FRONT TURN SIGNAL LAMP CIRCUIT

1. Turn ignition switch OFF.
2. Disconnect BCM connector and front combination lamp LH or RH connector.
3. Check continuity between BCM harness connector M20 (A) terminal 60 and front combination lamp LH harness connector E21 (B) terminal 4.

60 - 4 : Continuity should exist.

4. Check continuity between BCM harness connector M20 (A) terminal 61 and front combination lamp RH harness connector E20 (B) terminal 4.

61 - 4 : Continuity should exist.

OK or NG

- OK >> GO TO 3.

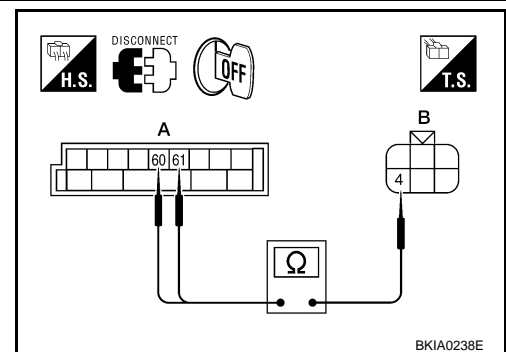

TURN SIGNAL AND HAZARD WARNING LAMPS

< SERVICE INFORMATION >

NG >> Repair harness or connector.

3.CHECK GROUND CIRCUIT

1. Check continuity between front combination lamp LH harness connector E21 terminal 2 and ground.

2 - Ground : Continuity should exist.

2. Check continuity between front combination lamp RH harness connector E20 terminal 2 and ground.

2 - Ground : Continuity should exist.

OK or NG

- OK >> Inspect connection at front combination lamp.
NG >> Repair harness.

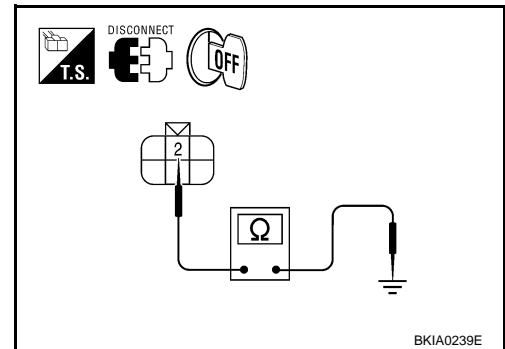

Rear Turn Signal Lamp Does Not Operate

INFOID:000000004409152

1.CHECK BULB

Verify the bulb standard of each turn signal lamp is correct. Refer to [LT-106, "Exterior Lamp"](#).

OK or NG

- OK >> GO TO 2.
NG >> Replace turn signal lamp bulb. Refer to [LT-56, "Bulb Replacement for Rear Turn Signal Lamp"](#).

2.CHECK REAR TURN SIGNAL LAMP CIRCUIT

1. Turn ignition switch OFF.
2. Disconnect BCM connector and rear combination lamp LH or RH connector.
3. Check continuity between BCM harness connector M20 (A) terminal 60 and rear combination lamp LH harness connector B25 (B) terminal 6.

60 - 6 : Continuity should exist.

4. Check continuity between BCM harness connector M20 (A) terminal 61 and rear combination lamp RH harness connector B42 (B) terminal 6.

61 - 6 : Continuity should exist.

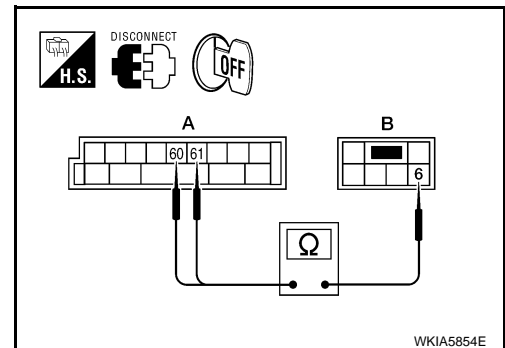

OK or NG

- OK >> GO TO 3.
NG >> Repair harness or connector.

3.CHECK GROUND CIRCUIT

1. Check continuity between rear combination lamp LH harness connector B25 terminal 4 and ground.

4 - Ground : Continuity should exist.

2. Check continuity between rear combination lamp RH harness connector B42 terminal 4 and ground.

4 - Ground : Continuity should exist.

OK or NG

- OK >> Check rear combination lamp connector for proper connection. Repair as necessary.
NG >> Repair harness or connector.

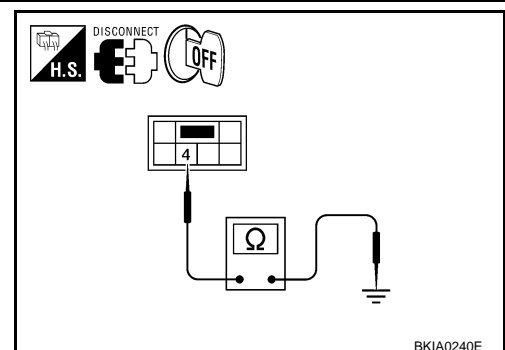

TURN SIGNAL AND HAZARD WARNING LAMPS

< SERVICE INFORMATION >

Hazard Warning Lamp Does Not Operate But Turn Signal Lamp Operates

INFOID:000000004409153

1. CHECK HAZARD SWITCH INPUT SIGNAL

④ With CONSULT-III

1. Select "BCM" on CONSULT-III. Select "FLASHER" on "SELECT TEST ITEM" screen.
2. Select "DATA MONITOR". Make sure that "HAZARD SW" turns ON-OFF linked with operation of hazard switch.

When hazard switch is in ON position : HAZARD SW ON

⊗ Without CONSULT-III

Check voltage between BCM harness connector and ground.

Terminal (+)		Terminal (-)	Condition	Voltage
BCM connector	Terminal			
M18	29	Ground	Hazard switch is ON	0V
			Hazard switch is OFF	Battery voltage

OK or NG

OK >> Replace BCM. Refer to [BCS-17. "Removal and Installation of BCM"](#).

NG >> GO TO 2.

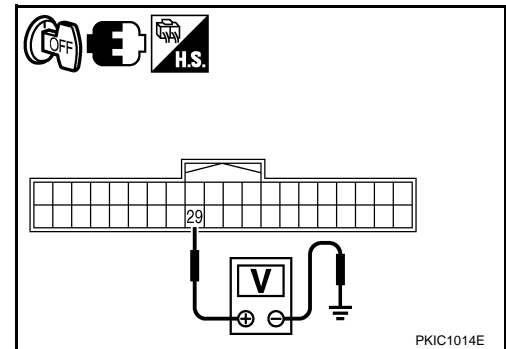

2. CHECK HAZARD SWITCH CIRCUIT

1. Turn ignition switch OFF.
2. Disconnect BCM connector and hazard switch connector.
3. Check continuity between BCM harness connector M18 (A) and hazard switch harness connector M102 (B).

A		B		Continuity
Connector	Terminal	Connector	Terminal	
M18	29	M102	2	Yes

OK or NG

OK >> GO TO 3.

NG >> Repair harness or connector.

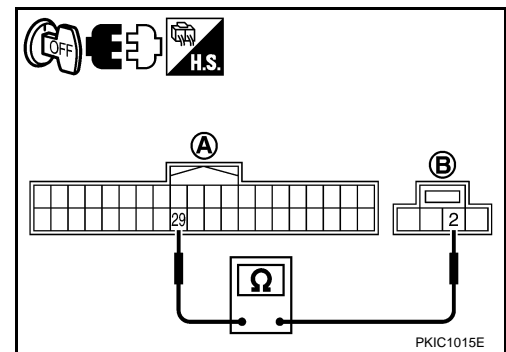

3. CHECK GROUND CIRCUIT

Check continuity between hazard switch harness connector M102 terminal 1 and ground.

1 – Ground : Continuity should exist.

OK or NG

OK >> GO TO 4.

NG >> Repair harness or connector.

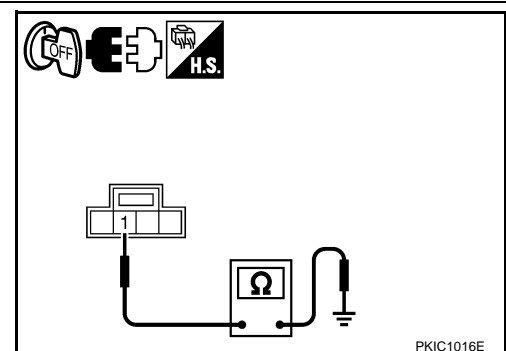

4. CHECK HAZARD SWITCH

TURN SIGNAL AND HAZARD WARNING LAMPS

< SERVICE INFORMATION >

1. Disconnect hazard switch connector.
2. Check continuity between hazard switch terminals.

Terminal		Condition	Continuity
Hazard switch			
1	2	Hazard switch is ON	Yes
		Hazard switch is OFF	No

OK or NG

OK >> Replace BCM if hazard warning lamps do not operate after setting the connector again. Refer to [BCS-17, "Removal and Installation of BCM"](#).

NG >> Replace hazard switch. Refer to [LT-58, "Removal and Installation"](#).

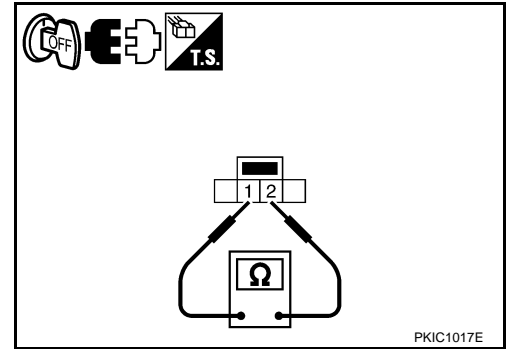

Turn Signal Indicator Lamp Does Not Operate

INFOID:000000004409154

1. CHECK CAN COMMUNICATION SYSTEM

Check CAN communication. Refer to [LAN-6, "System Description"](#).

OK or NG

OK >> Replace combination meter. Refer to [DI-22, "Removal and Installation"](#).

NG >> Repair as necessary.

Bulb Replacement for Front Turn Signal Lamp

INFOID:000000004409155

Refer to [LT-22, "Bulb Replacement"](#).

Bulb Replacement for Rear Turn Signal Lamp

INFOID:000000004409156

Refer to [LT-79, "Bulb Replacement"](#).

Removal and Installation of Front Turn Signal Lamp

INFOID:000000004409157

Refer to [LT-22, "Bulb Replacement"](#).

Removal and Installation of Rear Turn Signal Lamp

INFOID:000000004409158

Refer to [LT-80, "Removal and Installation"](#).

LIGHTING AND TURN SIGNAL SWITCH

< SERVICE INFORMATION >

LIGHTING AND TURN SIGNAL SWITCH

Removal and Installation

INFOID:000000004409159

REMOVAL

1. Remove steering column cover. Refer to [IP-11](#).
2. While pressing pawls (A) in direction as shown, pull lighting and turn signal switch (1) toward LH door and disconnect from the base.

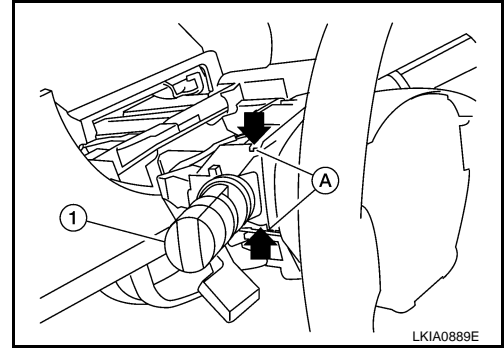

INSTALLATION

Installation is in the reverse order of removal.

A
B
C
D
E
F
G
H
I
J
LT
L
M
N
O
P

HAZARD SWITCH

< SERVICE INFORMATION >

HAZARD SWITCH

Removal and Installation

INFOID:000000004409160

REMOVAL

1. Remove the MT/CVT finisher. Refer to [IP-11. "Component Parts"](#).
2. Remove the hazard switch from the MT/CVT finisher.

INSTALLATION

Installation is in the reverse order of removal.

COMBINATION SWITCH

< SERVICE INFORMATION >

COMBINATION SWITCH

Wiring Diagram - COMBSW -

INFOID:000000004409161

LT-COMBSW-01

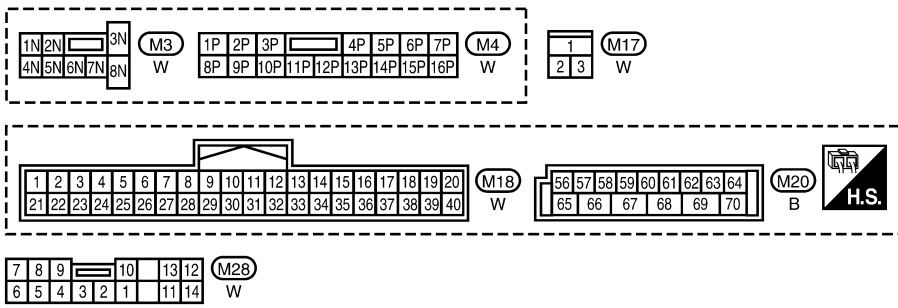
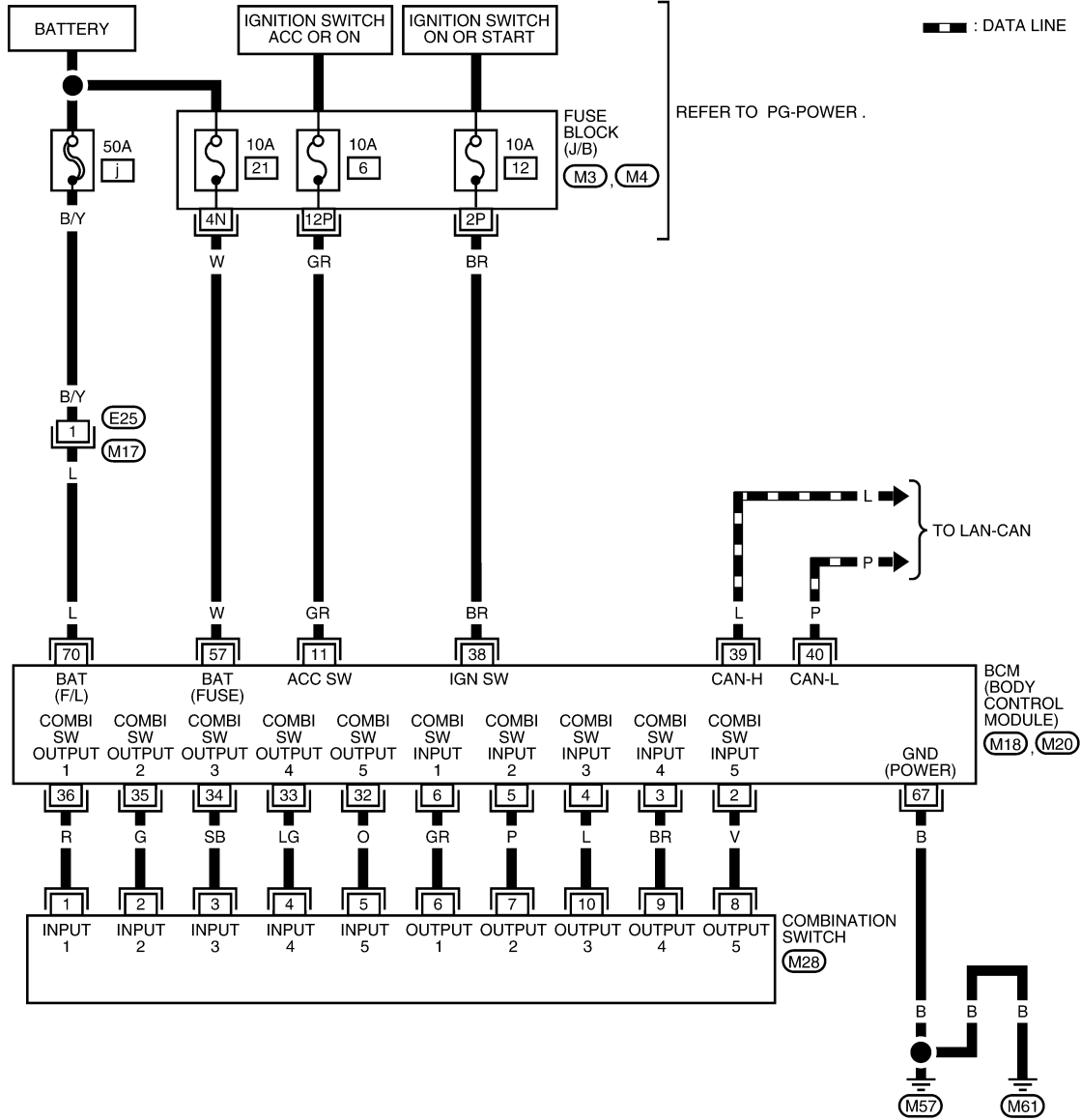

BKWA0796E

Combination Switch Reading Function

For details, refer to "Combination Switch Reading Function" .

INFOID:000000004409162

COMBINATION SWITCH

< SERVICE INFORMATION >

Terminal and Reference Value for BCM

INFOID:000000004409163

Refer to [BCS-11, "Terminal and Reference Value for BCM"](#).

CONSULT-III Function (BCM)

INFOID:000000004409164

Refer to [BCS-15, "CONSULT-III Function \(BCM\)"](#).

Combination Switch Inspection

INFOID:000000004409165

1.SYSTEM CHECK

Referring to table below, check which system malfunctioning switch belongs to.

System 1	System 2	System 3	System 4	System 5
—	FRONT WASHER	FRONT WIPER LO	TURN LH	TURN RH
FRONT WIPER HI	—	FRONT WIPER INT	PASSING	HEAD LAMP 1
INT VOLUME 1	—	—	HEAD LAMP 2	HI BEAM
—	INT VOLUME 3	—	—	LIGHT SW 1ST
INT VOLUME 2	—	—	FRONT FOG	—

>> Check the system to which the switch belongs, and GO TO 2.

2.SYSTEM CHECK

With CONSULT-III

1. Connect CONSULT-III, and select "COMB SW" on BCM "SELECT TEST ITEM" screen.
2. Select "DATA MONITOR".
3. Select "START", and confirm that other switches in the system operate normally.
Example: When turn signal LH is inoperative, confirm that PASSING, HEAD LAMP 2 or FRONT FOG (if equipped) turn ON-OFF normally.

Without CONSULT-III

Operate combination switch, and confirm that other switches in the system operate normally.
Example: When a turn signal switch is inoperative, confirm that FRONT WIPER LO or FRONT WIPER INT turn ON-OFF normally.

Check results

Other switches in the system operate normally.>>Replace lighting switch or wiper switch.

Other switches in the system do not operate normally.>>GO TO 3.

3.HARNES INSPECTION

1. Turn ignition switch OFF.
2. Disconnect BCM connector and combination switch connector.
3. Check for continuity between BCM harness connector of the suspect system and the corresponding combination switch harness connector.

COMBINATION SWITCH

< SERVICE INFORMATION >

Suspect system	A		B		Continuity	
	Connector	Terminal	Connector	Terminal		
1	M18	Input 1	6	M28	6	Yes
		Output 1	36		1	
2		Input 2	5		7	
		Output 2	35		2	
3		Input 3	4		10	
		Output 3	34		3	
4		Input 4	3		9	
		Output 4	33		4	
5		Input 5	2		8	
		Output 5	32		5	

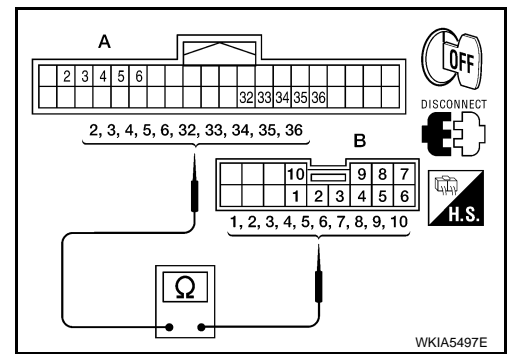

4. Check for continuity between the BCM harness connector in suspect system and ground.

Suspect system	BCM		Continuity		
	Connector	Terminal			
1	M18	Input 1	6	Ground	No
		Output 1	36		
2		Input 2	5		
		Output 2	35		
3		Input 3	4		
		Output 3	34		
4		Input 4	3		
		Output 4	33		
5		Input 5	2		
		Output 5	32		

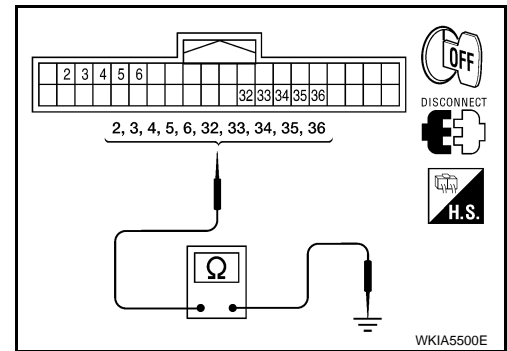

OK or NG

OK >> GO TO 4.

NG >> Check harness between BCM and combination switch for open or short circuit.

4. CHECK BCM OUTPUT TERMINAL

1. Connect BCM and combination switch connectors.
2. Turn ignition switch ON.
3. Turn lighting switch and wiper switch to OFF position.
4. Set wiper dial to position 4.
5. Check BCM output terminal voltage waveform of suspect system.

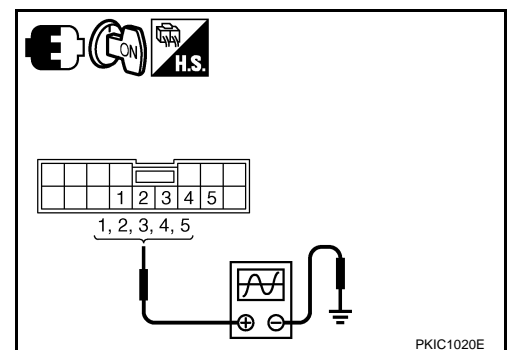

COMBINATION SWITCH

< SERVICE INFORMATION >

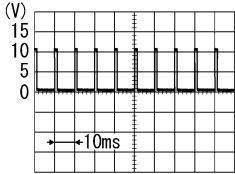
Suspect system	Terminal (+)		Terminal (-)	Reference value
	Combination switch connector	Terminal		
1	M28	1	Ground	 PKIB4958J 1.2V
2		2		
3		3		
4		4		
5		5		

OK or NG

OK >> Open circuit in combination switch, GO TO 5.

NG >> Replace BCM. Refer to [BCS-17, "Removal and Installation of BCM"](#).

5. COMBINATION SWITCH INSPECTION

Referring to table below, perform combination switch inspection.

Procedure									
1	2		3	4		5	6		7
Re-place lighting switch	Confirm check results	OK	INSPECTION END	Confirm check results	OK	INSPECTION END	Confirm check results	OK	INSPECTION END
		NG	Replace wiper switch		NG	Replace switch base		NG	Confirm symptom again

>> Inspection end.

Removal and Installation

INFOID:000000004409166

Refer to [LT-57](#).

STOP LAMP

< SERVICE INFORMATION >

STOP LAMP

Wiring Diagram - STOP/L -

INFOID:000000004409167

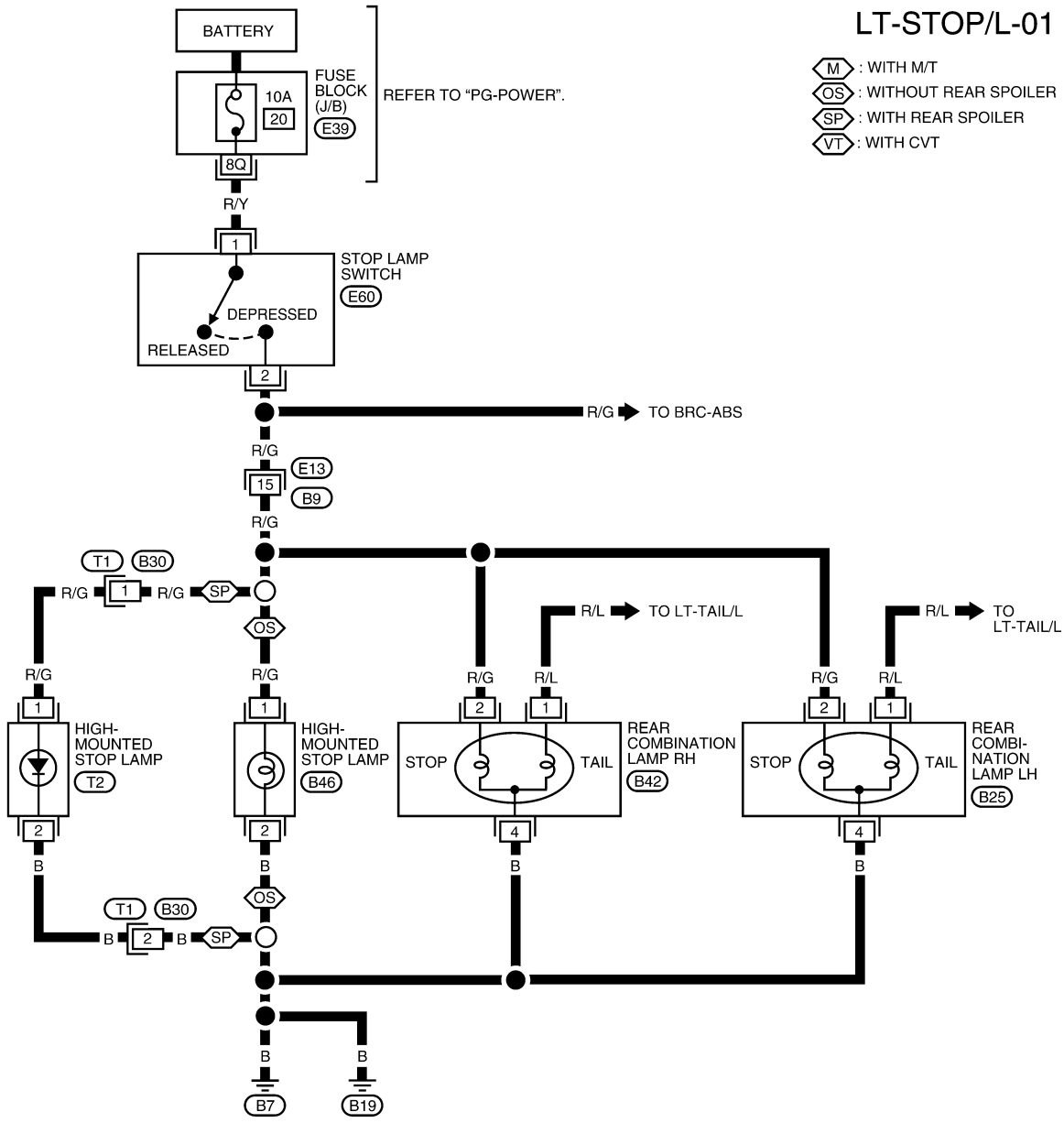

LT-STOP/L-01

- : WITH MT
- : WITHOUT REAR SPOILER
- : WITH REAR SPOILER
- : WITH CVT

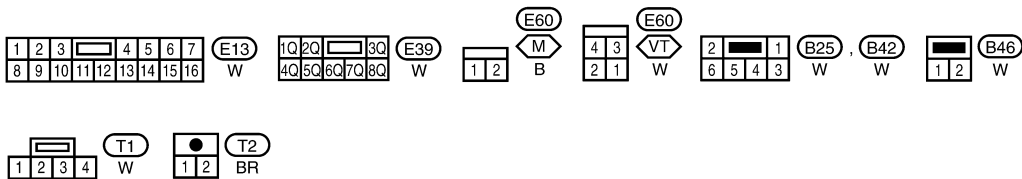

AWLWA0079GE

Bulb Replacement for High-Mounted Stop Lamp

INFOID:000000004409168

For non-SER vehicles refer to [LT-64, "Removal and Installation of High-Mounted Stop Lamp, All Except SE-R"](#).

STOP LAMP

< SERVICE INFORMATION >

For SER refer to [LT-64. "Removal and Installation of High-Mounted Stop Lamp, SE-R"](#).

Bulb Replacement for Rear Combination Lamp for Stop Lamp

INFOID:000000004409169

Refer to [LT-79. "Bulb Replacement"](#).

Removal and Installation of High-Mounted Stop Lamp, All Except SE-R

INFOID:000000004409170

REMOVAL

1. Unclip to release the rear high-mount stop lamp (1) from the rear parcel shelf finisher (2) and remove the rear high-mount stop lamp (1).
2. Disconnect the rear high-mounted stop lamp connector, turn the bulb socket counterclockwise and remove the high-mounted stop lamp bulb.

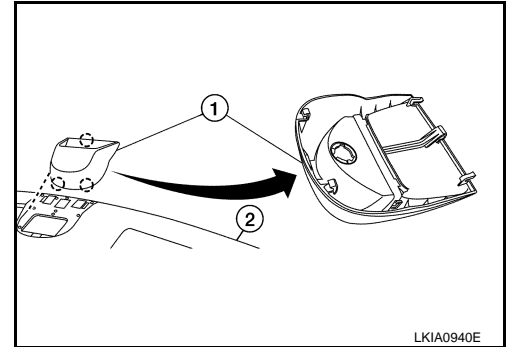

INSTALLATION

Installation is in the reverse order of removal.

Removal and Installation of High-Mounted Stop Lamp, SE-R

INFOID:000000004409171

REMOVAL

1. Remove the trunk lid finisher. Refer to [EI-43. "Removal and Installation"](#).
2. Remove the led high-mounted stop lamp screws (A), then remove the led high-mounted stop lamp assembly (2).
 - Rear air spoiler (1)

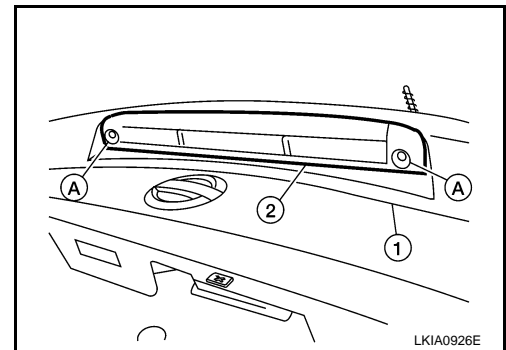

INSTALLATION

Installation is in the reverse order of removal.

Removal and Installation of Rear Combination Lamp for Stop Lamp

INFOID:000000004409172

Refer to [LT-80. "Removal and Installation"](#).

BACK-UP LAMP

< SERVICE INFORMATION >

BACK-UP LAMP

Wiring Diagram - BACK/L -

INFOID:000000004409173

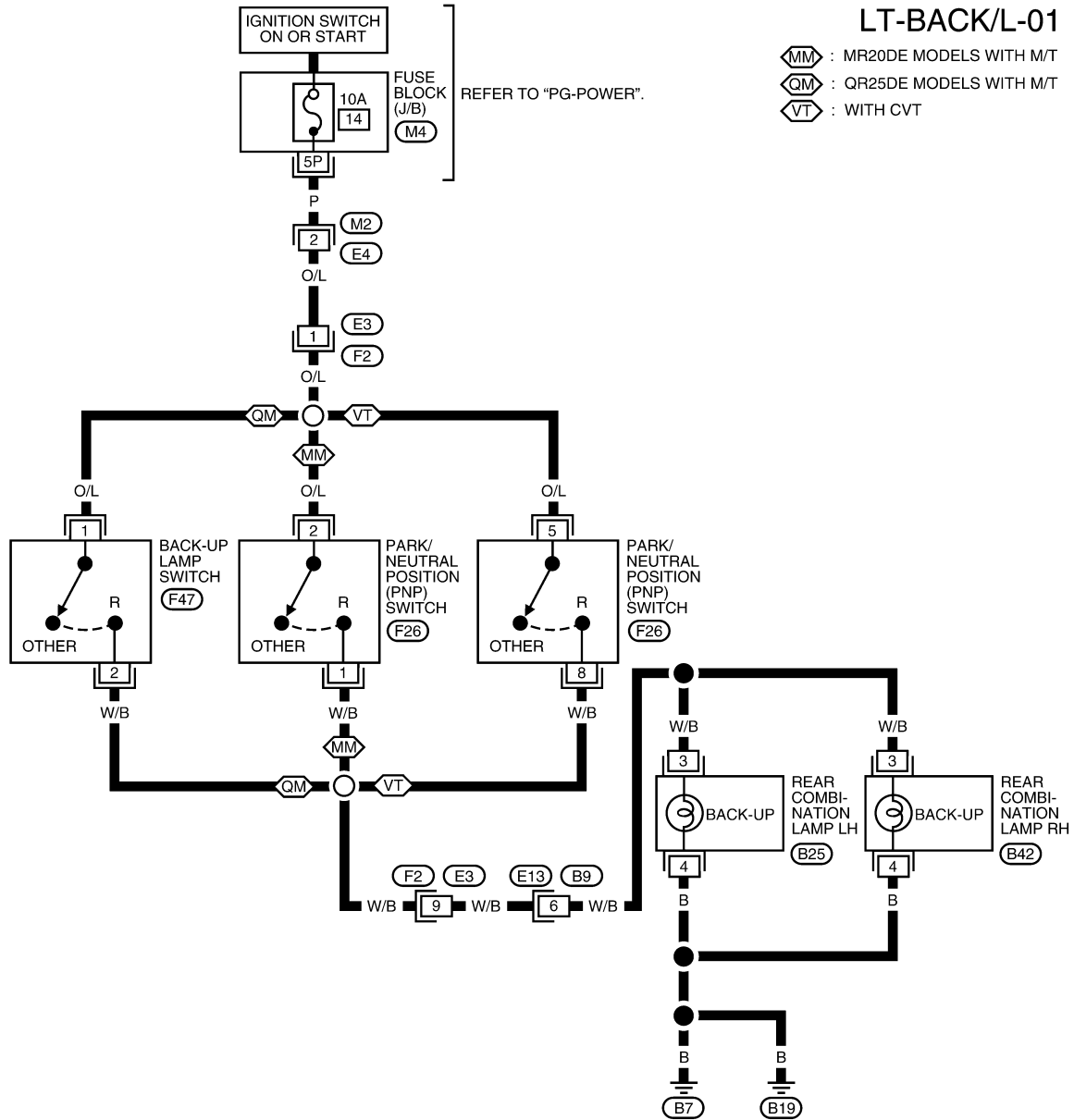

LT-BACK/L-01

- : MR20DE MODELS WITH M/T
- : QR25DE MODELS WITH M/T
- : WITH CVT

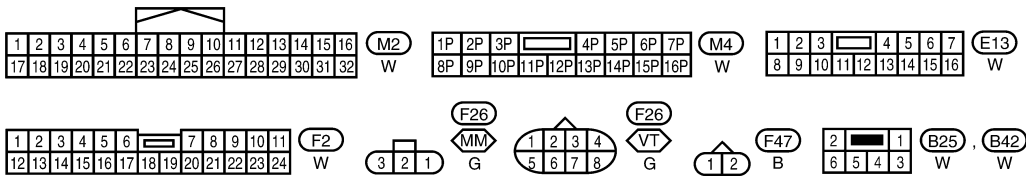

Bulb Replacement

Refer to [LT-79, "Bulb Replacement"](#).

AWLWA0080GE

INFOID:000000004409174

BACK-UP LAMP

< SERVICE INFORMATION >

Removal and Installation

INFOID:000000004409175

Refer to [LT-80, "Removal and Installation"](#).

PARKING, LICENSE PLATE AND TAIL LAMPS

< SERVICE INFORMATION >

PARKING, LICENSE PLATE AND TAIL LAMPS

Component Parts and Harness Connector Location

INFOID:000000004409176

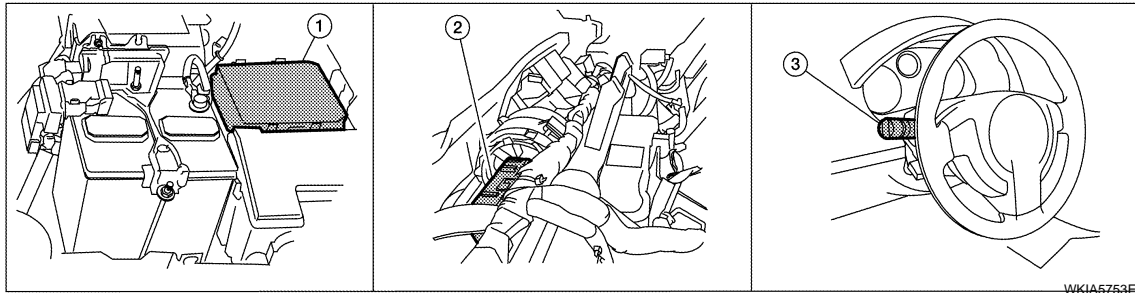

1. IPDM E/R E45, E46 and E48

2. BCM M18 and M20 (view with instrument panel removed)

3. Combination switch (lighting switch) M28

System Description

INFOID:000000004409177

The control of the parking, license plate and tail lamp operation is dependent upon the position of lighting switch. When the lighting switch is placed in the 1ST position, the BCM (body control module) receives input signal requesting the parking, license plate and tail lamps to illuminate. This input signal is communicated to the IPDM E/R (intelligent power distribution module engine room) via the CAN communication lines. The CPU (central processing unit) located in the IPDM E/R controls the tail lamp relay coil. This relay, when energized, directs power to parking, license plate and tail lamps, which then illuminate.

Power is supplied at all times

- to ignition relay located in IPDM E/R,
- to tail lamp relay located in IPDM E/R,
- through 15A fuse (No. 52, located in IPDM E/R) and
- through 20A fuse (No. 53, located in IPDM E/R)
- to the CPU located in the IPDM E/R,
- through 50A fusible link (letter j, located in fuse and fusible link block)
- to BCM terminal 70,
- through 10A fuse [No. 21, located in fuse block (J/B)],
- to BCM terminal 57.

With the ignition switch in the ON or START position, power is supplied

- through 10A fuse [No. 12, located in fuse block (J/B)]
- to BCM terminal 38,
- to ignition relay located in IPDM E/R and
- through the ignition relay
- to the CPU of the IPDM E/R.

With the ignition switch in the ACC or ON position, power is supplied

- through 10A fuse [No. 6, located in fuse block (J/B)]
- to BCM terminal 11.

Ground is supplied

- to BCM terminal 67
- through grounds M57 and M61,
- to IPDM E/R terminals 59 and 39
- through grounds E9, E15 (all models) and E24 (with MR20DE).

OPERATION BY LIGHTING SWITCH

With the lighting switch in the 1ST or 2ND position, the BCM receives an input signal requesting parking, license plate and tail lamps to illuminate. This input signal is communicated to the IPDM E/R via the CAN communication lines. The CPU, located in the IPDM E/R, controls the tail lamp relay coil. When energized, the tail lamp relay directs power

- through 10A fuse (No. 37, located in IPDM E/R),
- through IPDM E/R terminal 28
- to front combination lamp LH terminal 1, and
- through IPDM E/R terminal 29

A
B
C
D
E
F
G
H
I
J
LT
L
M
N
O
P

PARKING, LICENSE PLATE AND TAIL LAMPS

< SERVICE INFORMATION >

- to front combination lamp RH terminal 1,
- through 10A fuse (No. 36, located in IPDM E/R)
- through IPDM E/R terminal 27
- to rear combination lamp LH and RH terminal 1 and
- to license plate lamp LH and RH terminal 1.

Ground is supplied

- to front combination lamp LH and RH terminal 2
- through grounds E9, E15 (all models) and E24 (with MR20DE),
- to rear combination lamp LH and RH terminal 4 and
- to license plate lamp LH and RH terminal 2
- through grounds B7 and B19.

With power and ground supplied, parking, license plate and tail lamps illuminate.

COMBINATION SWITCH READING FUNCTION

Refer to [LT-59. "Combination Switch Reading Function"](#) .

EXTERIOR LAMP BATTERY SAVER CONTROL

When the combination switch (lighting switch) is in the 1ST (or 2ND) position and the ignition switch is turned from ON or ACC to OFF, the battery saver control feature is activated.

Under this condition, the parking, license and tail lamps remain illuminated for 5 minutes, then the parking, license plate and tail lamps are turned off.

Exterior lamp battery saver control mode can be changed by the function setting of CONSULT-III.

CAN Communication System Description

INFOID:000000004409178

Refer to [LAN-6. "System Description"](#).

PARKING, LICENSE PLATE AND TAIL LAMPS

< SERVICE INFORMATION >

Schematic

INFOID:000000004409179

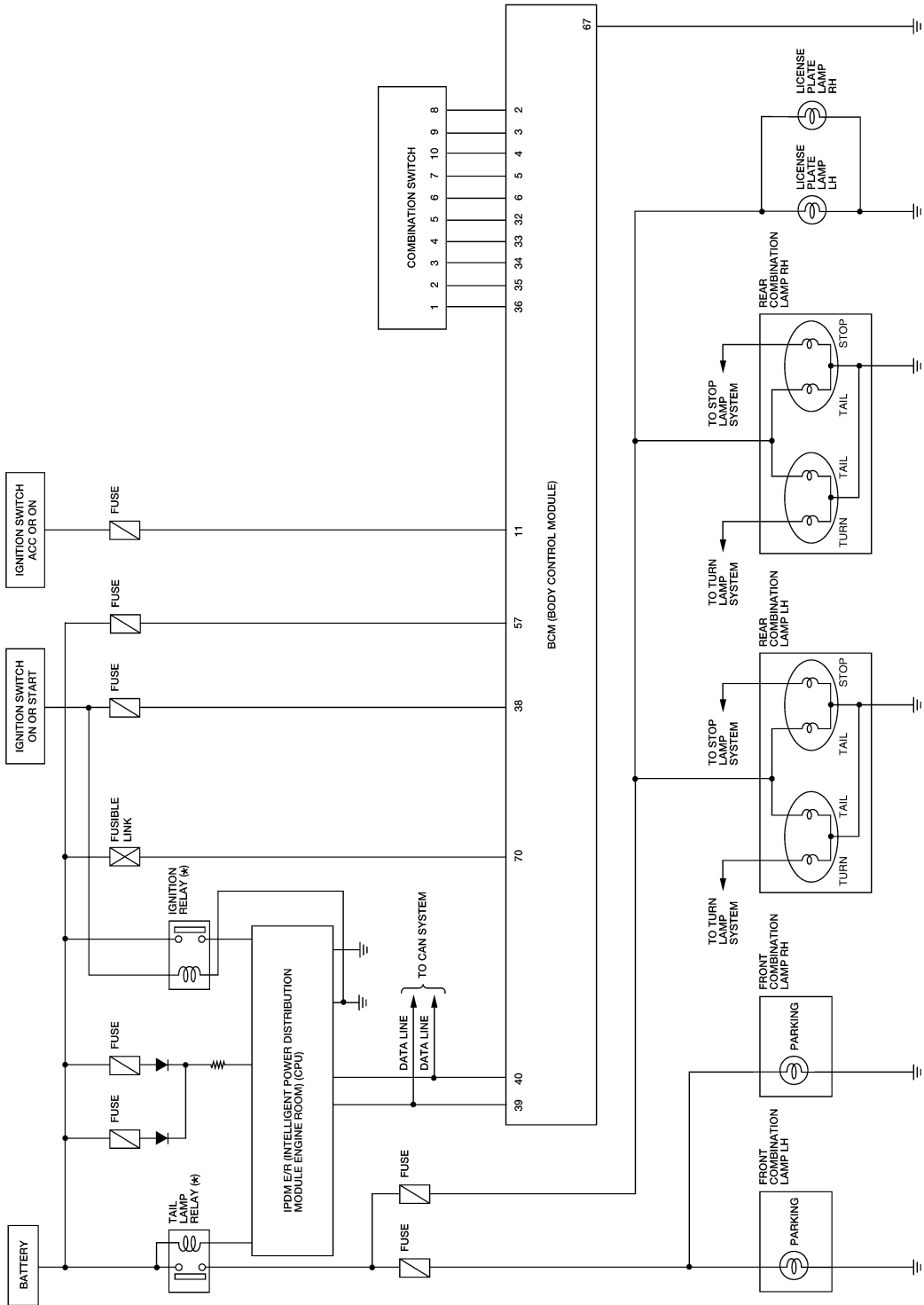

*: THIS RELAY IS BUILT INTO THE IPDM E/R (INTELLIGENT POWER DISTRIBUTION MODULE ENGINE ROOM)

A
B
C
D
E
F
G
H
I
J
LT
L
M
N
O
P

BKWA0799E

PARKING, LICENSE PLATE AND TAIL LAMPS

< SERVICE INFORMATION >

Wiring Diagram - TAIL/L -

INFOID:00000004409180

LT-TAIL/L-01

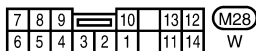
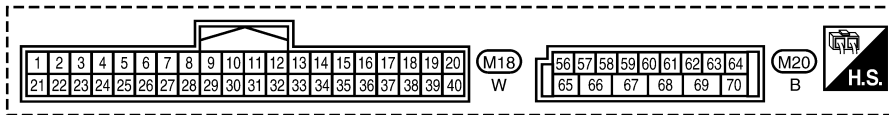
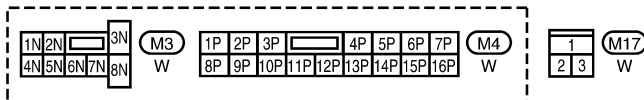
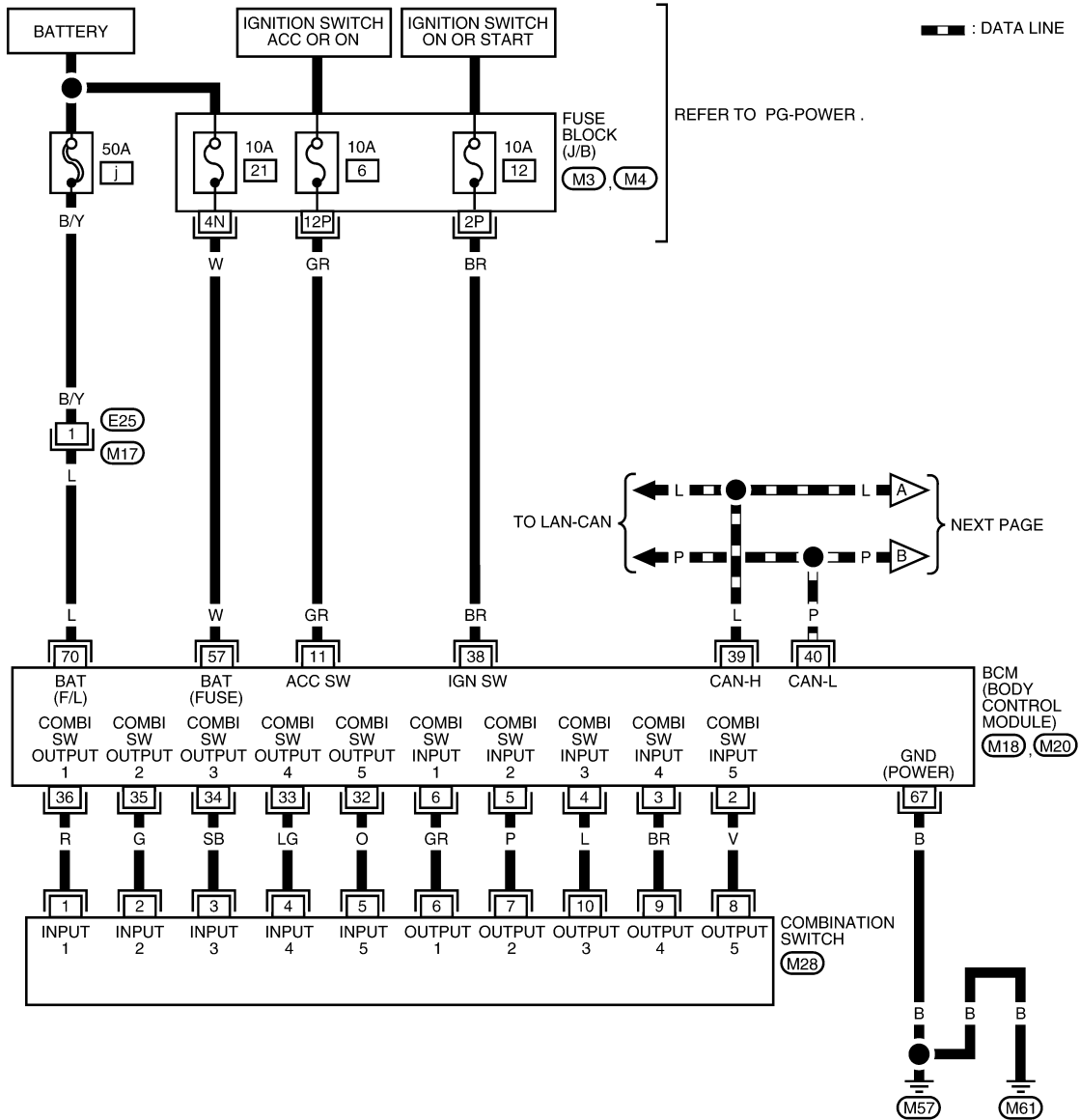

BKWA0800E

PARKING, LICENSE PLATE AND TAIL LAMPS

< SERVICE INFORMATION >

LT-TAIL/L-02

▬ : DATA LINE

MR : WITH MR20DE

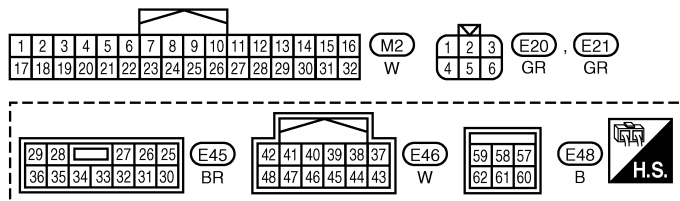
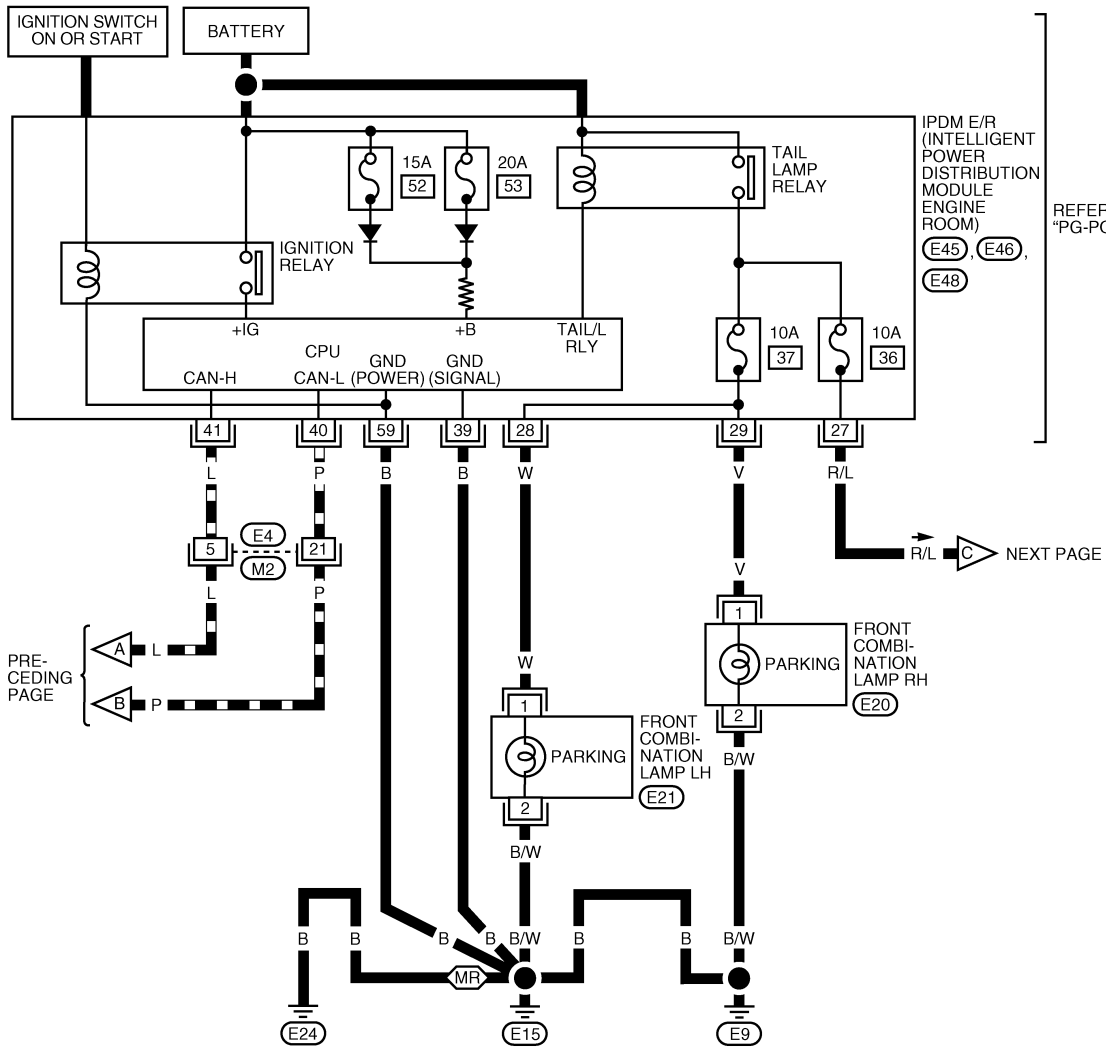

BKWA0839E

PARKING, LICENSE PLATE AND TAIL LAMPS

< SERVICE INFORMATION >

LT-TAIL/L-03

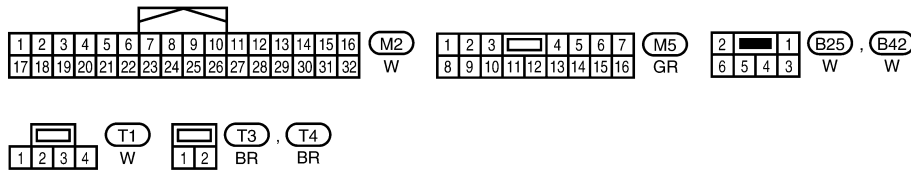
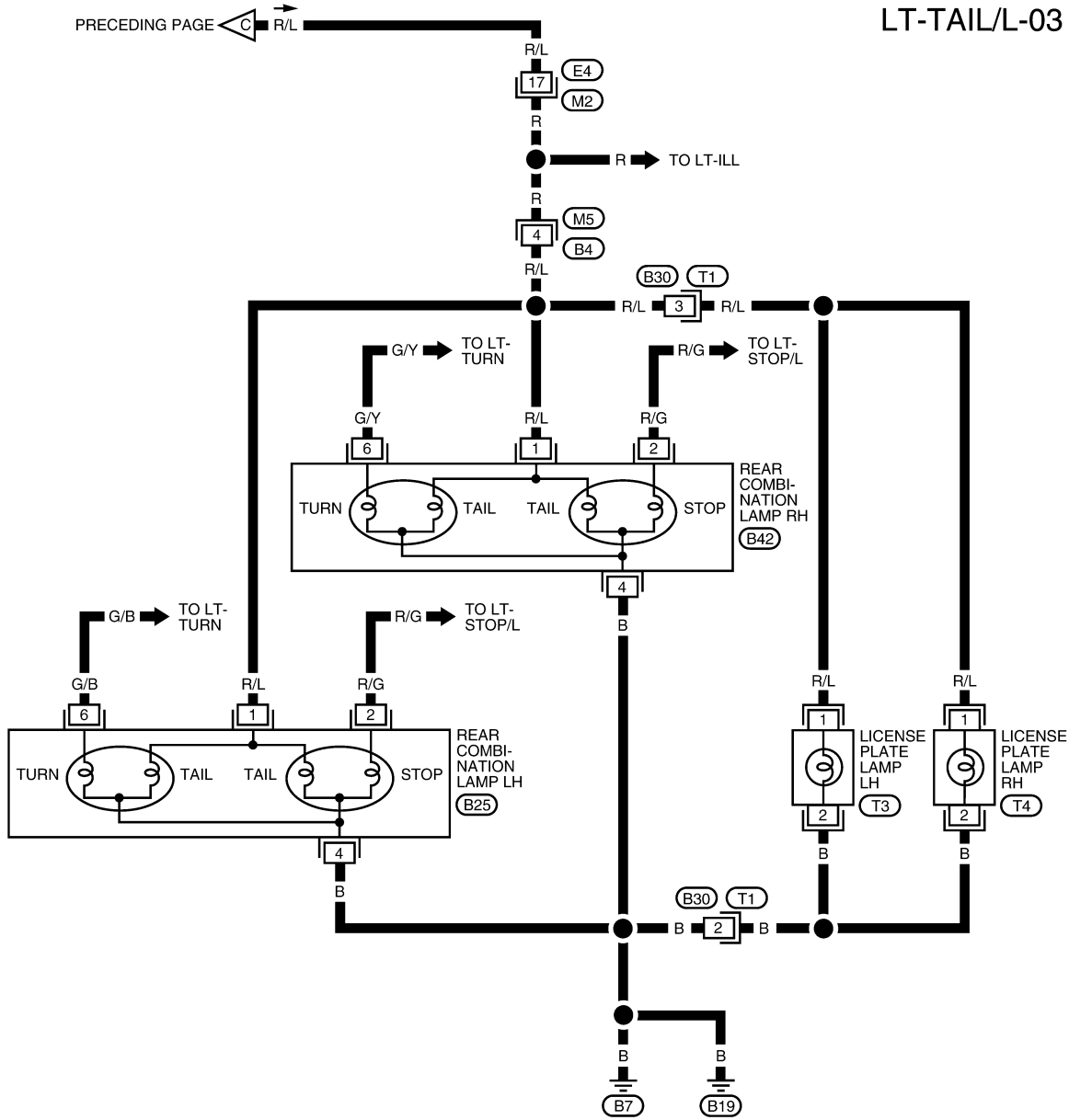

BKWA0802E

INFOID:000000004409181

Terminal and Reference Value for BCM

Refer to [BCS-11, "Terminal and Reference Value for BCM"](#).

Terminal and Reference Value for IPDM E/R

INFOID:000000004409182

Refer to [PG-24, "Terminal and Reference Value for IPDM E/R"](#).

PARKING, LICENSE PLATE AND TAIL LAMPS

< SERVICE INFORMATION >

How to Proceed with Trouble Diagnosis

INFOID:000000004409183

1. Confirm the symptom or customer complaint.
2. Understand operation description and function description. Refer to [LT-67, "System Description"](#).
3. Perform the preliminary check. Refer to [LT-73, "Preliminary Check"](#).
4. Check symptom and repair or replace the cause of the malfunction.
5. Do the parking, license plate and tail lamps operate normally? If YES, GO TO 6. If NO, GO TO 4.
6. Inspection End.

Preliminary Check

INFOID:000000004409184

CHECK POWER SUPPLY AND GROUND CIRCUIT FOR BCM

Refer to [BCS-14, "BCM Power Supply and Ground Circuit Inspection"](#).

CHECK POWER SUPPLY AND GROUND CIRCUIT FOR IPDM E/R

Refer to [PG-26, "IPDM E/R Power/Ground Circuit Inspection"](#).

CONSULT-III Function (BCM)

INFOID:000000004409185

Refer to [BCS-15, "CONSULT-III Function \(BCM\)"](#).

CONSULT-III Function (IPDM E/R)

INFOID:000000004409186

Refer to [PG-18, "CONSULT-III Function \(IPDM E/R\)"](#).

Parking, License Plate and Tail Lamps Do Not Illuminate

INFOID:000000004409187

1. CHECK TAIL LAMP FUSE

Inspect tail lamp 10A fuses (No. 36 and 37, located in IPDM E/R).

OK or NG

- OK >> GO TO 2.
NG >> Repair harness.

2. CHECK COMBINATION SWITCH INPUT SIGNAL

With CONSULT-III

1. Select "BCM" on CONSULT-III. Select "HEAD LAMP" on "SELECT TEST ITEM" screen.
2. Select "DATA MONITOR". Make sure "LIGHT SW 1ST" turns ON-OFF linked with operation of lighting switch.

When lighting switch is 1ST : LIGHT SW 1ST ON position

Without CONSULT-III

Refer to [LT-60, "Combination Switch Inspection"](#).

OK or NG

- OK >> GO TO 3.
NG >> Check combination switch (lighting switch). Refer to [LT-60, "Combination Switch Inspection"](#).

3. ACTIVE TEST

With CONSULT-III

1. Select "IPDM E/R" on CONSULT-III, and select "ACTIVE TEST".
2. Select "TAIL LAMP" on "SELECT TEST ITEM" screen.
3. Touch "ON" on "ACTIVE TEST" screen.
4. Make sure parking, license plate and tail lamps operate.

Parking, license plate and tail lamps should operate.

Without CONSULT-III

PARKING, LICENSE PLATE AND TAIL LAMPS

< SERVICE INFORMATION >

1. Start auto active test. Refer to [PG-20, "Auto Active Test"](#).
2. Make sure parking, license plate and tail lamps operate.

Parking, license plate and tail lamps should operate.

OK or NG

- OK >> GO TO 4.
 NG >> Replace the IPDM E/R if the parking, license and tail lamps do not start operating after resetting connector. Refer to [PG-27, "Removal and Installation of IPDM E/R"](#).

4.CHECK IPDM E/R

1. Select "IPDM E/R" on CONSULT-III, and select "DATA MONITOR".
2. Make sure "TAIL&CLR REQ" turns ON when lighting switch is in 1ST position.

When lighting switch is 1ST : TAIL&CLR REQ ON position

OK or NG

- OK >> Replace IPDM E/R. Refer to [PG-27, "Removal and Installation of IPDM E/R"](#).
 NG >> Replace BCM. Refer to [BCS-17, "Removal and Installation of BCM"](#).

Front Parking Lamps Do Not Illuminate (License Plate and Tail Lamps Operate Normally)

INFOID:000000004409188

1.CHECK FUSE

Inspect parking lamp 10A fuse (No. 37, located in IPDM E/R)

OK or NG

- OK >> GO TO 2.
 NG >> Repair harness.

2.CHECK INPUT SIGNAL

Ⓜ With CONSULT-III

1. Turn ignition switch OFF.
2. Disconnect front combination lamp connectors.
3. Turn ignition switch ON.
4. Select "IPDM E/R" on CONSULT-III, and select "ACTIVE TEST".
5. Select "TAIL LAMP" on "SELECT TEST ITEM" screen.
6. Touch "ON" on "ACTIVE TEST" screen.
7. When tail lamp relay is operating, check voltage between front combination lamp and ground.

Ⓜ Without CONSULT-III

1. Turn ignition switch OFF.
2. Disconnect front combination lamp connectors.
3. Turn ignition switch ON.
4. Start auto active test. Refer to [PG-20, "Auto Active Test"](#).
5. When tail lamp relay is operating, check voltage between front combination lamp and ground.

Terminal (+)		Terminal (-)	Voltage
Front combination lamp connector	Terminal		
RH	E20	1	Ground
LH	E21		

OK or NG

- OK >> GO TO 4.
 NG >> GO TO 3.

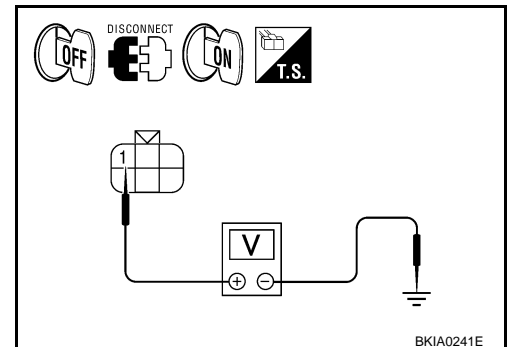

PARKING, LICENSE PLATE AND TAIL LAMPS

< SERVICE INFORMATION >

3. CHECK PARKING LAMP CIRCUIT

1. Turn ignition switch OFF.
2. Disconnect IPDM E/R connector.
3. Check continuity between IPDM E/R harness connector (A) and front combination lamp harness connector (B).

A		B		Continuity	
Connector	Terminal	Connector	Terminal		
E45	29	RH	E20	1	Yes
	28	LH	E21		

OK or NG

- OK >> Replace IPDM E/R. Refer to [PG-27, "Removal and Installation of IPDM E/R"](#).
- NG >> Repair harness or connector.

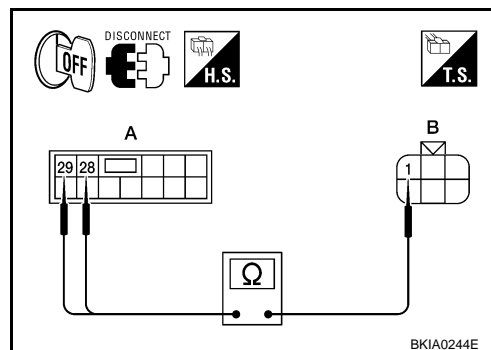

4. CHECK PARKING LAMPS GROUND CIRCUIT

Check continuity between front combination lamp harness connector and ground.

Front combination lamp connector		Terminal	Ground	Continuity
RH	E20	2		
LH	E21			

OK or NG

- OK >> Check bulbs.
- NG >> Repair harness or connector.

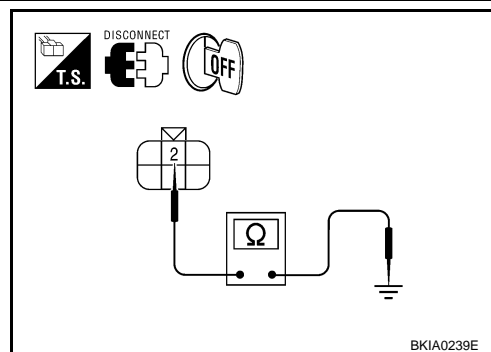

License Plate and Tail Lamps Do Not Illuminate (Front Parking Lamps Operate Normally)

INFOID:000000004409189

1. CHECK FUSE

Inspect tail lamp 10A fuse (No. 36, located in IPDM E/R)

OK or NG

- OK >> GO TO 2.
- NG >> Repair harness.

2. CHECK INPUT SIGNAL

Ⓜ With CONSULT-III

1. Turn ignition switch OFF.
2. Disconnect license plate lamp and rear combination lamp connectors.
3. Turn ignition switch ON.
4. Select "IPDM E/R" on CONSULT-III, and select "ACTIVE TEST".
5. Select "TAIL LAMP" on "SELECT TEST ITEM" screen.
6. Touch "ON" on "ACTIVE TEST" screen.
7. When tail lamp relay is operating, check voltage between license plate lamp and rear combination lamp harness connectors and ground.

Ⓜ Without CONSULT-III

1. Turn ignition switch OFF.
2. Disconnect license plate lamp and rear combination lamp connectors.
3. Turn ignition switch ON.
4. Start auto active test. Refer to [PG-20, "Auto Active Test"](#).
5. When tail lamp relay is operating, check voltage between license plate lamp and rear combination lamp harness connectors and ground.

PARKING, LICENSE PLATE AND TAIL LAMPS

< SERVICE INFORMATION >

Terminal		Terminal	(-)	Voltage
(+)				
License plate lamp connector		1	Ground	Battery voltage
RH	T4			
LH	T3			

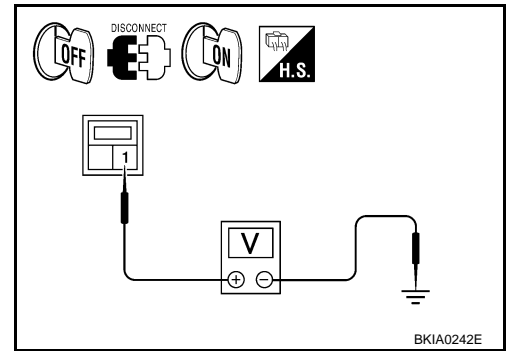

Terminal		Terminal	(-)	Voltage
(+)				
Rear combination lamp connector (Tail lamp)		1	Ground	Battery voltage
RH	B42			
LH	B25			

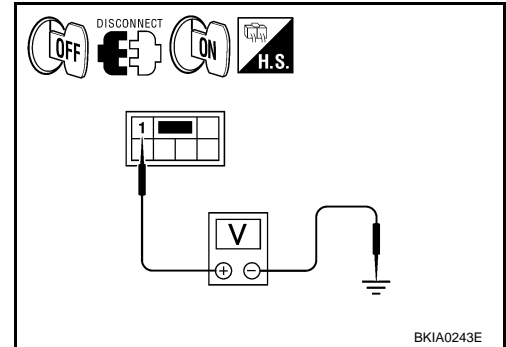

OK or NG

- OK >> GO TO 4.
- NG >> GO TO 3.

3. CHECK LICENSE PLATE AND TAIL LAMP CIRCUIT

1. Turn ignition switch OFF.
2. Disconnect IPDM E/R connector.
3. Check continuity between IPDM E/R harness connector (A) and license plate lamp harness connector (B).

A		B		Continuity	
Connector	Terminal	Connector	Terminal		
E45	27	RH	T4	1	Yes
		LH	T3		

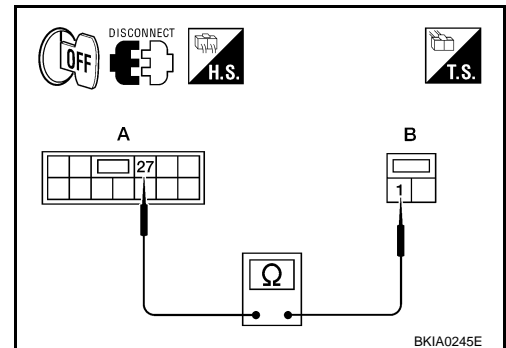

4. Check continuity between IPDM E/R harness connector (A) and rear combination lamp harness connector (B).

A		B		Continuity	
Connector	Terminal	Connector	Terminal		
E45	27	RH	B42	1	Yes
		LH	B25		

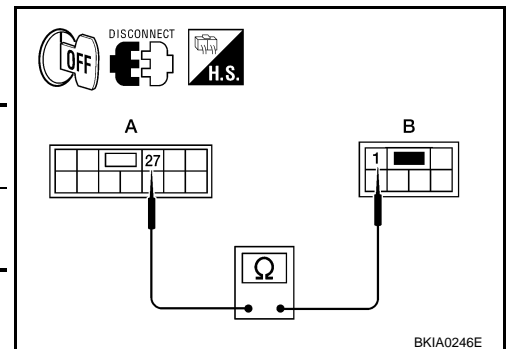

OK or NG

- OK >> Replace IPDM E/R. Refer to [PG-27, "Removal and Installation of IPDM E/R"](#).
- NG >> Repair harness or connector.

4. CHECK PARKING, LICENSE PLATE AND TAIL LAMPS GROUND CIRCUIT

PARKING, LICENSE PLATE AND TAIL LAMPS

< SERVICE INFORMATION >

1. Check continuity between license plate lamp harness connector and ground.

License plate lamp connector		Terminal	Ground	Continuity
RH	T4	2		Yes
LH	T3			

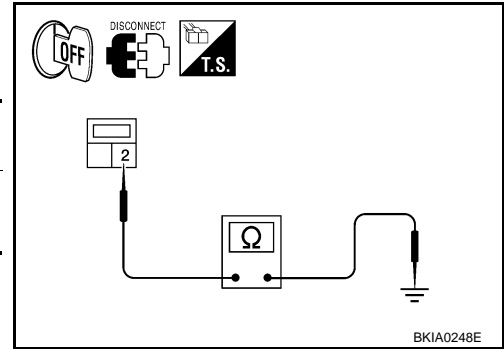

2. Check continuity between rear combination lamp harness connector and ground.

Rear combination lamp connector		Terminal	Ground	Continuity
RH	B42	T4		Yes
LH	B25			

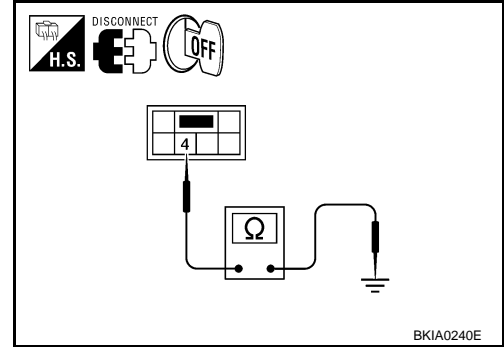

OK or NG

- OK >> Check bulbs.
- NG >> Repair harness or connector.

Parking, License Plate and Tail Lamps Do Not Turn OFF (After Approx. 10 Minutes)

INFOID:000000004409190

- This symptom is related to the ignition relay in IPDM E/R. Refer to [PG-18, "Function of Detecting Ignition Relay Malfunction"](#).
- Select "BCM" on CONSULT-III. Select "HEAD LAMP" on "SELECT TEST ITEM" screen and select "DATA MONITOR". If "LIGHT SW 1ST" is OFF when lighting switch is OFF, replace IPDM E/R.

Bulb Replacement

INFOID:000000004409191

PARKING LAMP

Refer to [LT-79, "Bulb Replacement"](#).

LICENSE PLATE LAMP

1. Remove the license plate lamp. Refer to [LT-77, "Removal and Installation"](#).
2. Turn bulb socket counterclockwise and unlock it.
3. Remove bulb from the socket.
4. Installation is in the reverse order of removal.

TAIL LAMP

Refer to [LT-80, "Removal and Installation"](#).

Removal and Installation

INFOID:000000004409192

PARKING LAMP

Refer to [LT-79, "Component"](#).

LICENSE PLATE LAMP

Removal

1. Remove the license lamp finisher. Refer to [EI-25, "Removal and Installation"](#).

PARKING, LICENSE PLATE AND TAIL LAMPS

< SERVICE INFORMATION >

2. Remove license plate lamp screw (A) and remove the license plate lamp (1).
3. Disconnect the license plate lamp connector and remove the licence plate lamp.

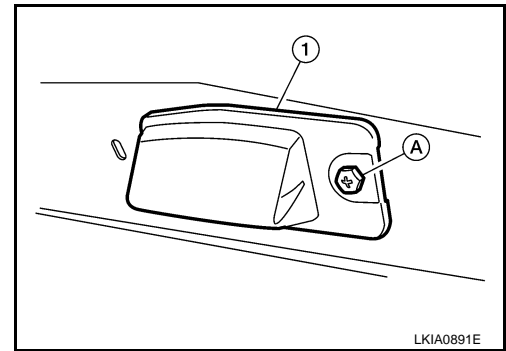

Installation

Installation is in the reverse order of removal.

TAIL LAMP

Refer to [LT-80, "Removal and Installation"](#).

REAR COMBINATION LAMP

< SERVICE INFORMATION >

REAR COMBINATION LAMP

Component

INFOID:000000004409193

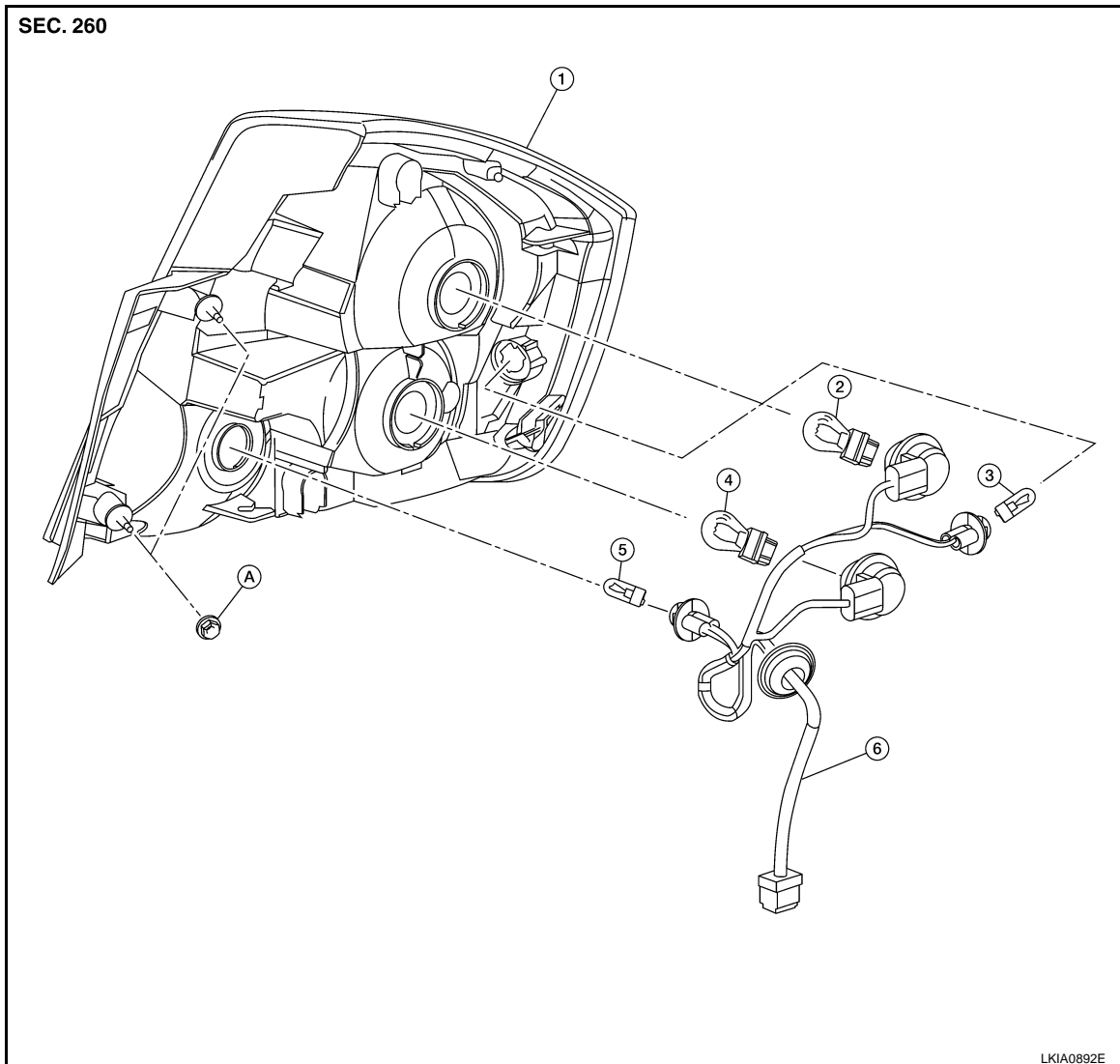

- | | | |
|--|-------------------------------|----------------------------------|
| 1. Rear combination lamp housing assembly | 2. Turn signal/tail lamp bulb | 3. Parking lamp bulb |
| 4. Tail/stop lamp bulb | 5. Back-up lamp bulb | 6. Rear combination lamp harness |
| A. Rear combination lamp housing assembly nuts | | |

Bulb Replacement

INFOID:000000004409194

REMOVAL

1. Remove the rear combination lamp. Refer to [LT-80, "Removal and Installation"](#).
2. Turn the bulb socket counterclockwise and unlock it.
3. Remove the bulb.

INSTALLATION

Installation is in the reverse order of removal.

REAR COMBINATION LAMP

< SERVICE INFORMATION >

Removal and Installation

INFOID:000000004409195

REMOVAL

1. Remove the luggage compartment side finisher. Refer to [EI-43](#).
2. Detach the harness clips and remove rear combination lamp housing assembly nuts.
3. Pull the rear combination lamp toward the rear of the vehicle.
4. Disconnect rear combination lamp connector, and remove rear combination lamp.

INSTALLATION

Installation is in the reverse order of removal.

Disassembly and Assembly

INFOID:000000004409196

DISASSEMBLY

1. Turn the turn signal/tail lamp bulb socket counterclockwise and remove.
2. Turn the parking lamp bulb socket counterclockwise and remove.
3. Turn the rear tail/stop lamp bulb socket counterclockwise and remove.
4. Turn the back-up lamp bulb socket counterclockwise and remove.
5. Remove the bulbs from the rear combination lamp harness sockets.

ASSEMBLY

Assembly is in the reverse order of disassembly.

INTERIOR LAMP

< SERVICE INFORMATION >

INTERIOR LAMP

Map Lamp

INFOID:000000004409197

BULB REPLACEMENT

Removal

1. Remove the map lamp.
2. Twist and remove the bulbs (1) from lamp.

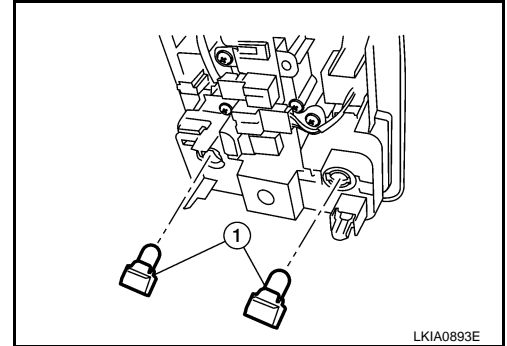

Installation

Installation is in the reverse order of removal.

REMOVAL AND INSTALLATION

Removal

1. Remove the map lamp lens.
2. Remove the screw (A) from the map lamp (1).
3. Disconnect map lamp connector and remove map lamp (1).

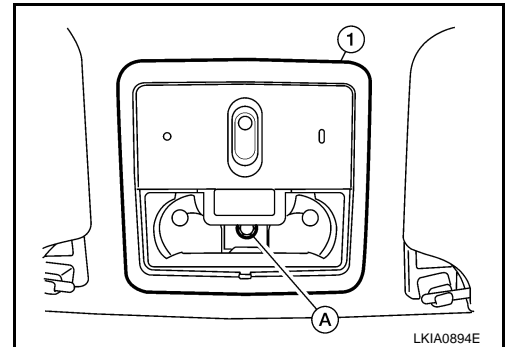

Installation

Installation is in the reverse order of removal.

Trunk Room Lamp

INFOID:000000004409198

BULB REPLACEMENT

Removal

1. Open trunk room lamp cover.
2. Remove the bulb.

Installation

Installation is in the reverse order of removal.

REMOVAL AND INSTALLATION

Removal

A
B
C
D
E
F
G
H
I
J
LT
L
M
N
O
P

INTERIOR LAMP

< SERVICE INFORMATION >

1. Open trunk room lamp cover.
2. Push the trunk room lamp pawl tab (A).
3. Pull the trunk room lamp (1) toward the side and down to remove.
4. Disconnect trunk room lamp connector.

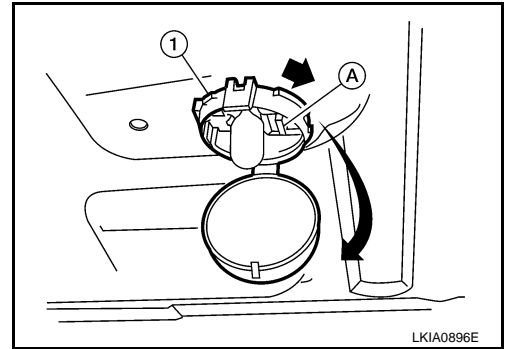

Installation

Installation is in the reverse order of removal.

INTERIOR ROOM LAMP

< SERVICE INFORMATION >

INTERIOR ROOM LAMP

Component Parts and Harness Connector Location

INFOID:000000004409199

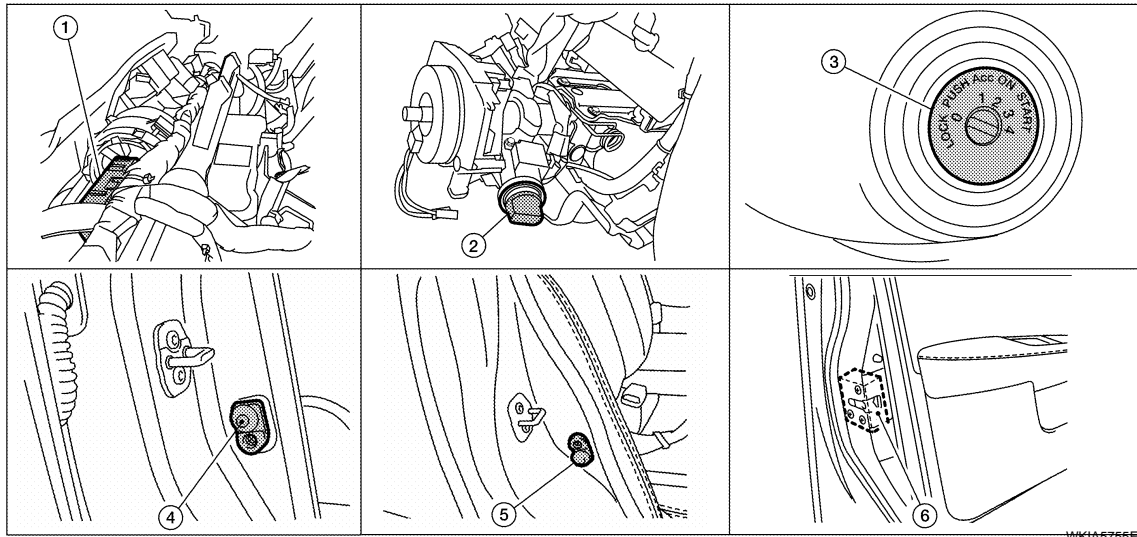

1. BCM M18, M19 and M20 (view with dash panel removed)
2. Key switch and ignition knob switch (with Intelligent Key) M49
3. Key switch (without Intelligent Key) M50
4. Front door switch LH B21 and RH B28
5. Rear door switch LH B26 and RH B41
6. Front door lock assembly LH (key cylinder switch) D9

System Description

INFOID:000000004409200

When room lamp switch is in DOOR position, room lamp ON/OFF is controlled by timer according to signals from switches including key switch, front door switch LH, unlock signal from keyfob, door lock and unlock switch, key cylinder lock and unlock switch, ignition switch.

When room lamp turns ON, there is a gradual brightening over 1 second.

When room lamp turns OFF, there is a gradual dimming over 1 second.

Interior room lamp timer is controlled by BCM (body control module).

Interior room lamp timer control settings can be changed with CONSULT-III.

POWER SUPPLY AND GROUND

Power is supplied at all times (without Intelligent Key system)

- through 10A fuse [No. 19, located in fuse block (J/B)]
- to key switch terminal 2,
- through 10A fuse [No. 21, located in fuse block (J/B)]
- to BCM terminal 57,
- through 50A fusible link (letter j, located in fuse and fusible link box)
- to BCM terminal 70.

Power is supplied at all times (with Intelligent Key system)

- through 10A fuse (No. 9, located in fuse and fusible link box)
- to key switch and ignition knob switch terminals 2 and 4,
- through 10A fuse [No. 21, located in fuse block (J/B)]
- to BCM terminal 57,
- through 50A fusible link (letter j, located in fuse and fusible link box)
- to BCM terminal 70.

When key is inserted in the key switch, power is supplied (without Intelligent Key system)

- through key switch terminal 1
- to BCM terminal 37.

When key is inserted in the key switch and ignition knob switch, power is supplied (with Intelligent Key system)

- through key switch and ignition knob switch terminal 1
- to BCM terminal 37.

When ignition knob switch is pushed, power is supplied (with Intelligent Key system)

INTERIOR ROOM LAMP

< SERVICE INFORMATION >

- through key switch and ignition knob switch terminal 3
- to Intelligent Key unit terminal 27.

With the ignition switch in the ON or START position, power is supplied

- through 10A fuse [No. 12, located in fuse block (J/B)]
- to BCM terminal 38.

Ground is supplied

- to BCM terminal 67
- through grounds M57 and M61.

When front door LH is opened, ground is supplied

- to BCM terminal 47
- through front door switch LH terminal 2
- through case ground of front door switch LH.

When front door RH is opened, ground is supplied

- to BCM terminal 12
- through front door switch RH terminal 2
- through case ground of front door switch RH.

When rear door LH is opened, ground is supplied

- to BCM terminal 48
- through rear door switch LH terminal 2
- through case ground of rear door switch LH.

When rear door RH is opened, ground is supplied

- to BCM terminal 13
- through rear door switch RH terminal 2
- through case ground of rear door switch RH.

When trunk is opened, ground is supplied

- to BCM terminal 42
- through trunk room lamp switch terminal 1
- through trunk room lamp switch terminal 2
- through grounds B7 and B19.

When front door LH is unlocked by front door key cylinder switch LH, the BCM receives a ground signal

- to BCM terminal 7
- through front door key cylinder switch LH terminal 5
- through front door key cylinder switch LH terminal 4
- through grounds M57 and M61.

When a signal, or combination of signals is received by BCM, ground is supplied

- to interior room lamp terminal 1
- through BCM terminal 63.

With power and ground supplied, the interior room lamp illuminates.

SWITCH OPERATION

Power is supplied

- through BCM terminal 56
- to trunk room lamp terminal 1,
- to vanity mirror lamp LH and RH terminal 1 (with vanity lamps),
- to map lamp terminal 2 (with map lamp) and
- to interior room lamp terminal 2.

When trunk room lamp is ON (trunk is open), ground is supplied

- to trunk room lamp terminal 2
- through BCM terminal 49.

When vanity mirror lamp LH or RH switch is ON (with vanity lamps), ground is supplied

- to vanity mirror lamp LH or RH terminal 2
- through grounds M57 and M61.

When map lamp switch is ON (with map lamp), ground is supplied

- to map lamp terminal 1
- through grounds M57 and M61.

When interior room lamp switch is ON, ground is supplied

- to interior room lamp
- through interior room lamp case ground.

INTERIOR ROOM LAMP TIMER OPERATION

Without Intelligent Key System

INTERIOR ROOM LAMP

< SERVICE INFORMATION >

When room lamp switch is in DOOR position, and when all conditions below are met, BCM performs timer control (maximum 30 seconds) for room lamp ON/OFF.

In addition, when the interior room lamp turns ON or OFF there is gradual brightening or dimming over 1 second.

Power is supplied

- through 10A fuse [No. 19, located in fuse block (J/B)]
- to key switch terminal 2.

When the key is removed from ignition key cylinder (key switch OFF), power will not be supplied to BCM terminal 37.

When front door lock assembly LH (key cylinder switch) is unlocked, ground is supplied

- to BCM terminal 7
- through front door key cylinder switch LH terminal 5
- through front door key cylinder switch LH terminal 4
- through grounds M57 and M61.

At the time that front door LH is opened, BCM detects that front door LH is unlocked. It determines that interior room lamp timer operation condition is met, and turns the room lamp ON for 30 seconds.

When key is in ignition key cylinder,

Power is supplied

- through key switch terminal 1
- to BCM terminal 37.

When key is removed from key switch (key switch OFF), the power supply to BCM terminal 37 is terminated. BCM detects that key has been removed, determines that interior room lamp timer conditions are met, and turns the room lamp ON for 30 seconds.

When front door LH opens → closes, and the key is not inserted in the key switch (key switch OFF), voltage at BCM terminal 47 changes between 0V (door open) → 12V (door closed). The BCM determines that conditions for room lamp operation are met and turns the room lamp ON for 30 seconds.

Interior room lamp timer control is canceled under the following conditions

- Front door LH is locked (locked front door key cylinder switch LH).
- Front door LH is opened (front door switch LH).
- Ignition switch ON.

With Intelligent Key System

When the room lamp switch is in DOOR position, and when all conditions below are met, BCM performs timer control (maximum 30 second) for room lamp ON/OFF.

In addition, when interior room lamp turns ON or OFF there is gradual brightening or dimming over 1 second.

Power is supplied

- through 10A fuse [No. 9, located in fuse block (J/B)]
- to key switch and ignition knob switch terminals 2 and 4.

When key is removed from ignition key cylinder (key switch OFF), power will not be supplied to BCM terminal 37.

When the ignition knob switch is released, power will not be supplied to Intelligent Key unit terminal 27.

When front door key cylinder switch LH is unlocked, ground is supplied

- to BCM terminal 7
- through front door key cylinder switch LH terminal 5
- through front door key cylinder switch LH terminal 4
- through grounds M57 and M61.

At the time the front door LH is opened, the BCM detects the front door LH is unlocked. It determines that the interior room lamp timer operation conditions are met, and interior room lamp ON for 30 seconds.

When the key is in ignition key cylinder (key switch ON), or ignition knob switch is pushed, power is supplied

- through key switch and ignition knob switch terminal 1
- to BCM terminal 37, or
- through key switch and ignition knob switch terminal 3
- to Intelligent Key unit terminal 27.

When the key is removed from key switch (key switch OFF), power supply to BCM terminal 37 is terminated. When the ignition knob switch is released, power supply to intelligent key unit is terminated. The BCM detects that the key has been removed, determines that interior room lamp timer conditions are met, and turns room lamp ON for 30 seconds.

When the front door LH opens → closes, and key is not inserted in key switch (or ignition knob switch is released), BCM terminal 47 changes between 0V (door open) → 12V (door closed). BCM determines that conditions for room lamp operation are met, and turns room lamp ON for 30 seconds.

Interior room lamp timer control is canceled under the following conditions:

- Front door LH is locked (with keyfob or front door key cylinder switch LH).

A

B

C

D

E

F

G

H

I

J

LT

L

M

N

O

P

INTERIOR ROOM LAMP

< SERVICE INFORMATION >

- Front door LH is opened (front door switch LH).
- Ignition switch ON.

INTERIOR LAMP BATTERY SAVER CONTROL

If an interior room lamp is left ON, it will not be turned OFF even when door is closed.

BCM turns off interior lamp automatically to save battery 30 minutes after ignition switch is turned off.

After lamps are turned OFF by the battery saver system, the lamps illuminate again when

- front door key cylinder switch LH is locked or unlocked
- door is opened or closed
- key is removed from ignition key cylinder or inserted in ignition key cylinder, or the ignition knob switch is pushed or released (with intelligent key system).

Interior lamp battery saver control time period can be changed by the function setting of CONSULT-III.

INTERIOR ROOM LAMP

< SERVICE INFORMATION >

Schematic

INFOID:000000004409201

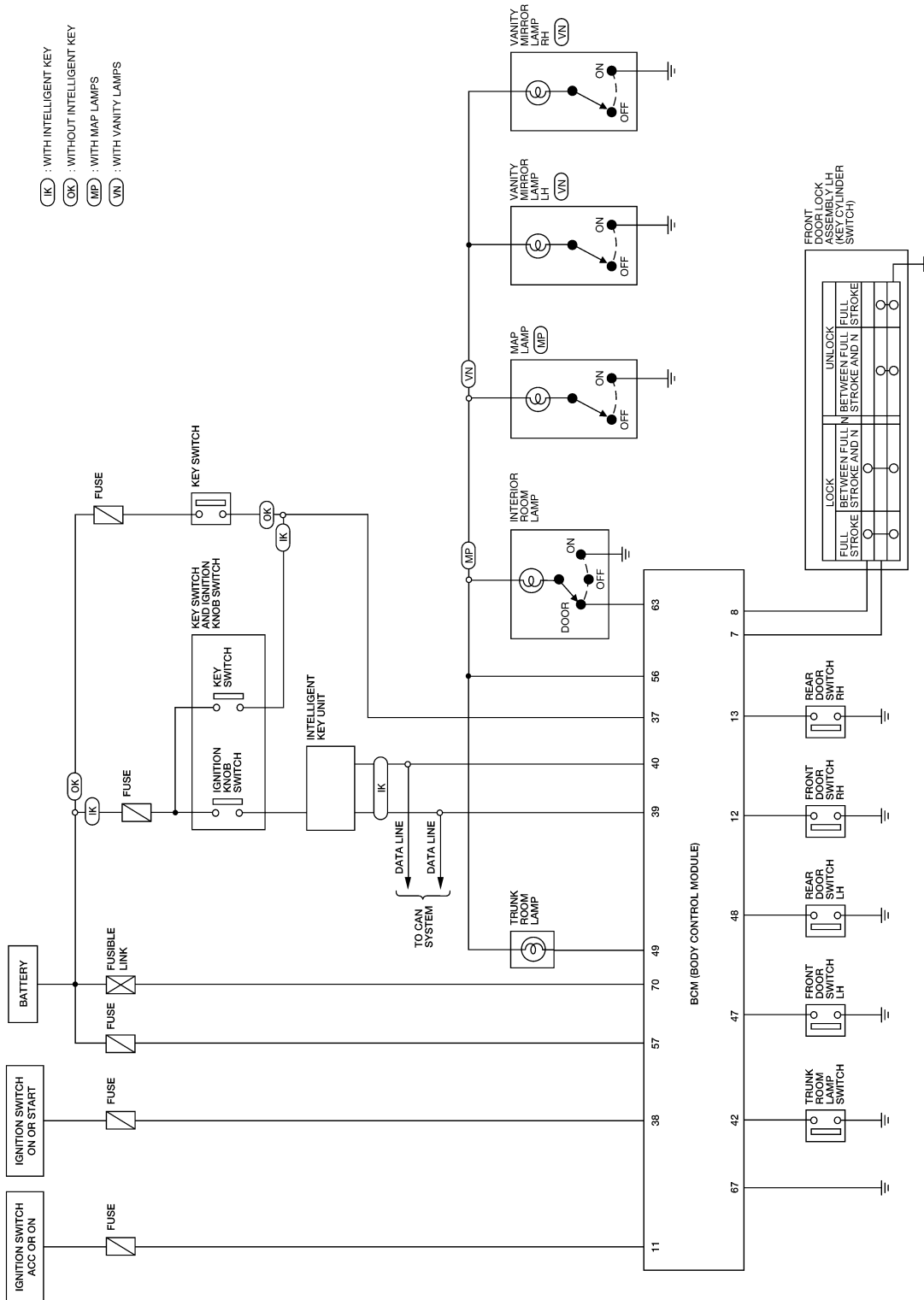

WKWA5863E

A
B
C
D
E
F
G
H
I
J
LT
L
M
N
O
P

INTERIOR ROOM LAMP

< SERVICE INFORMATION >

Wiring Diagram - INT/L -

INFOID:000000004409202

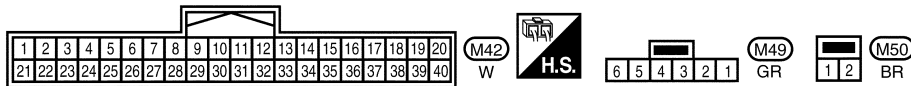
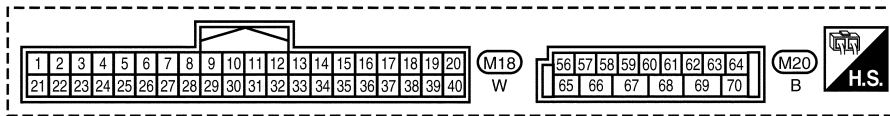
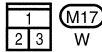
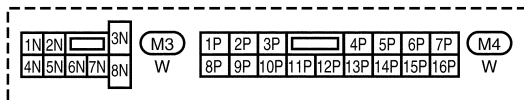
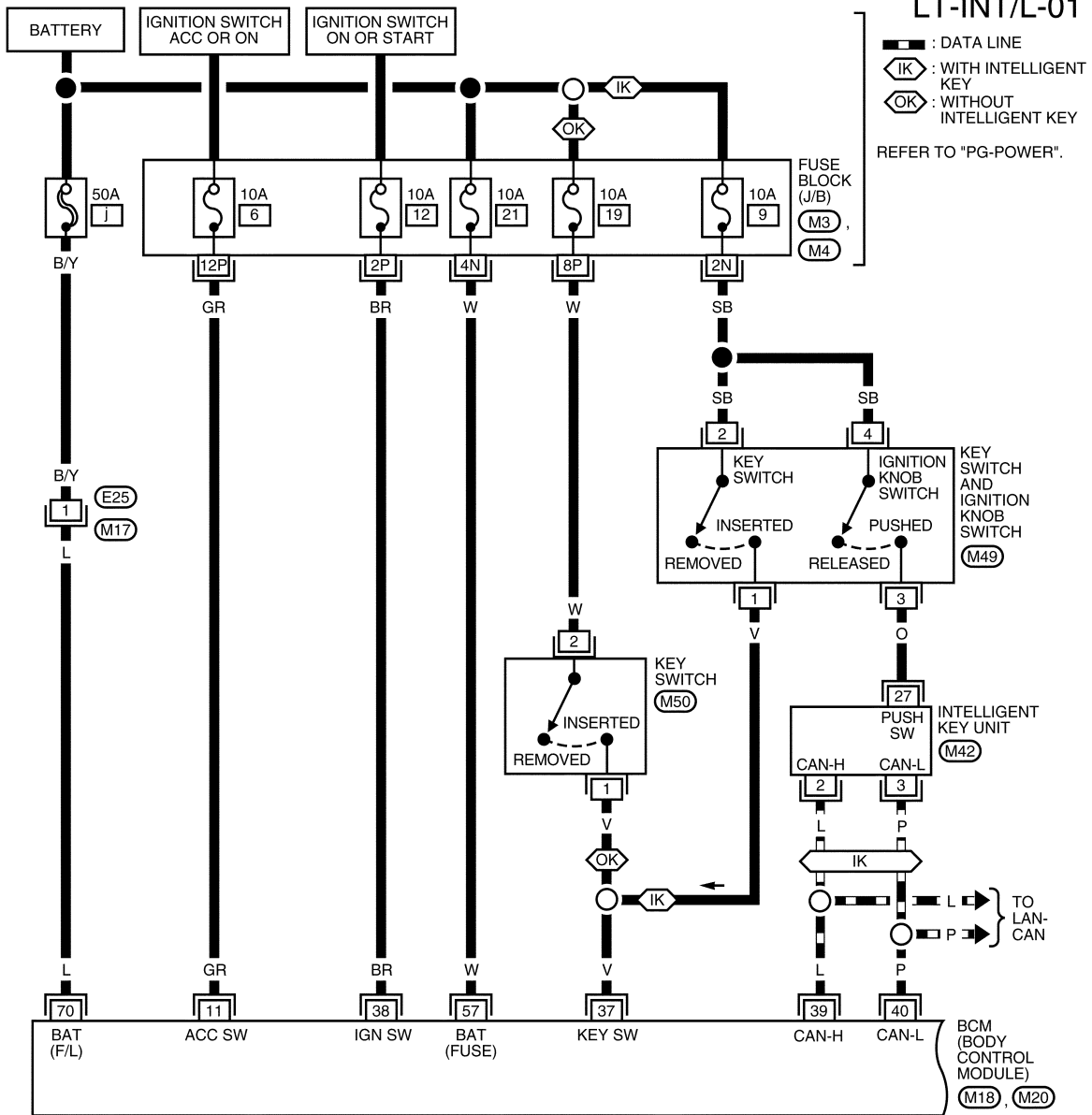

WKWA5864E

INTERIOR ROOM LAMP

< SERVICE INFORMATION >

LT-INTL/L-02

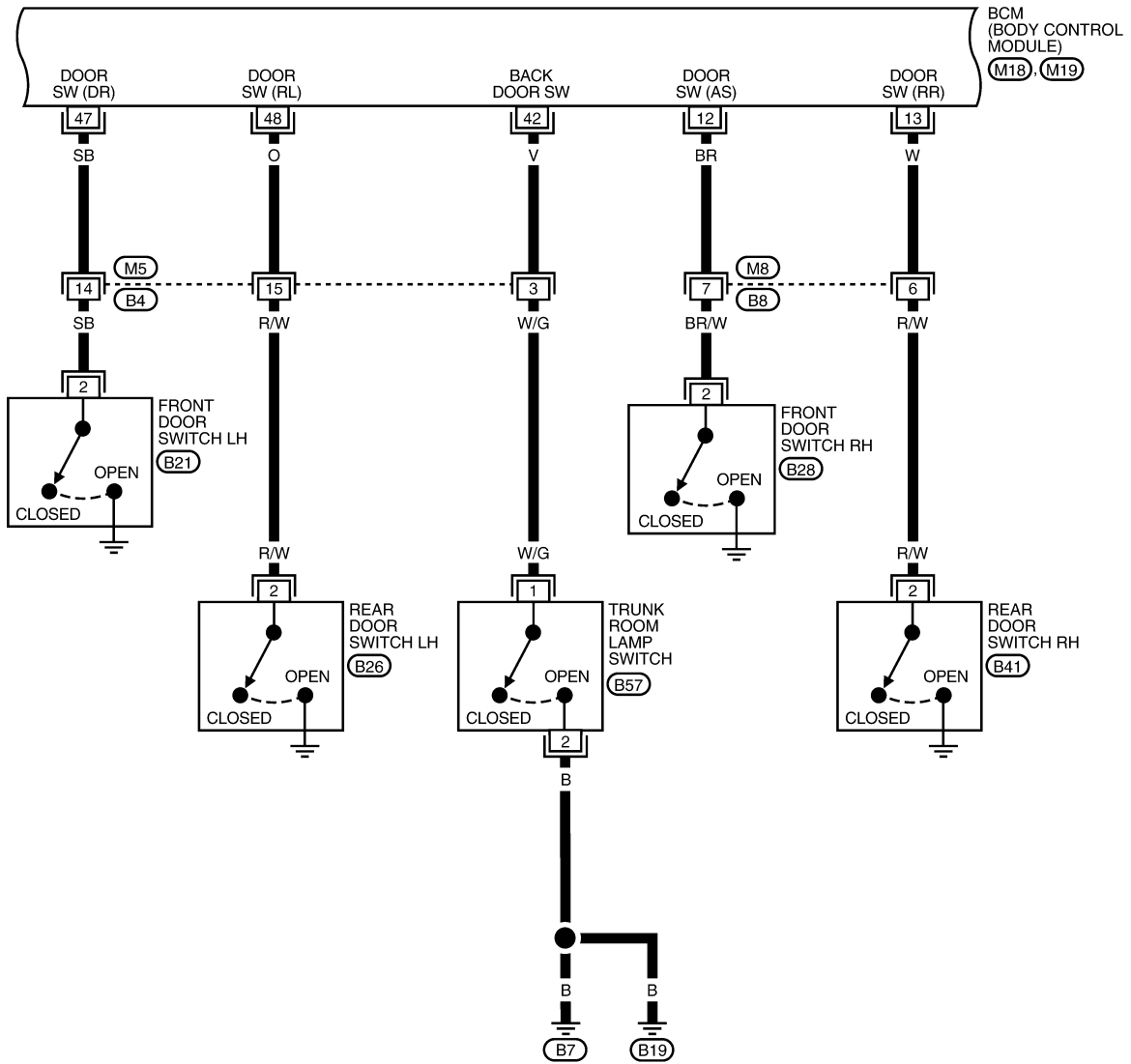

1	2	3	4	5	6	7	M5	M8		
8	9	10	11	12	13	14	15	16	GR	W

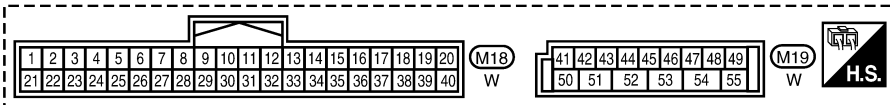

1	B21	B26	B28	B41	2 1	B57
2	W	W	W	W		W
3						

BKWA0805E

INTERIOR ROOM LAMP

< SERVICE INFORMATION >

LT-INT/L-03

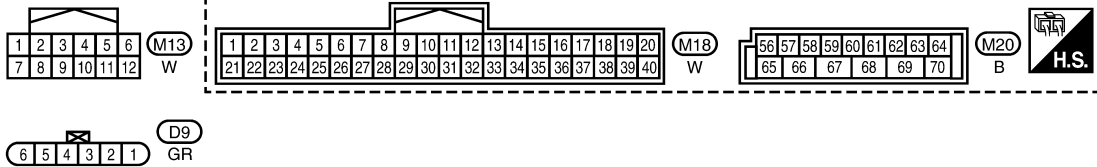
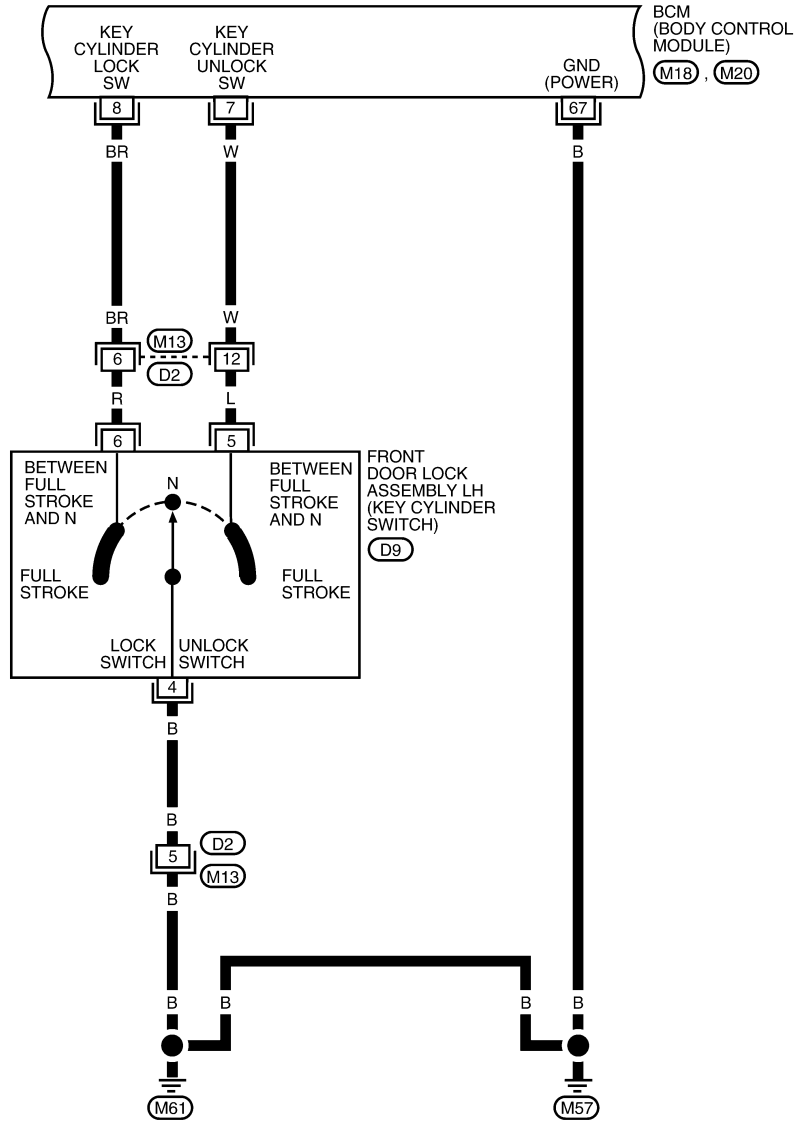

BKWA0806E

INTERIOR ROOM LAMP

< SERVICE INFORMATION >

LT-INT/L-04

MP : WITH MAP LAMPS
 VN : WITH VANITY LAMPS

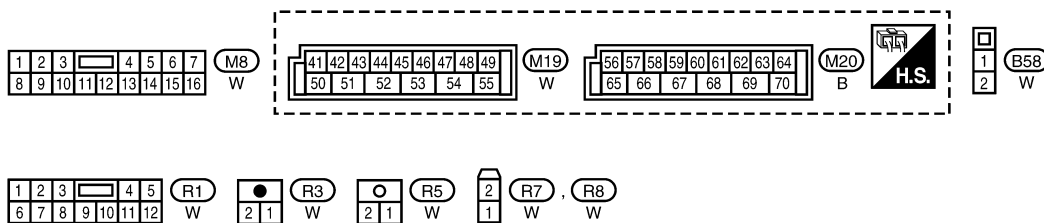
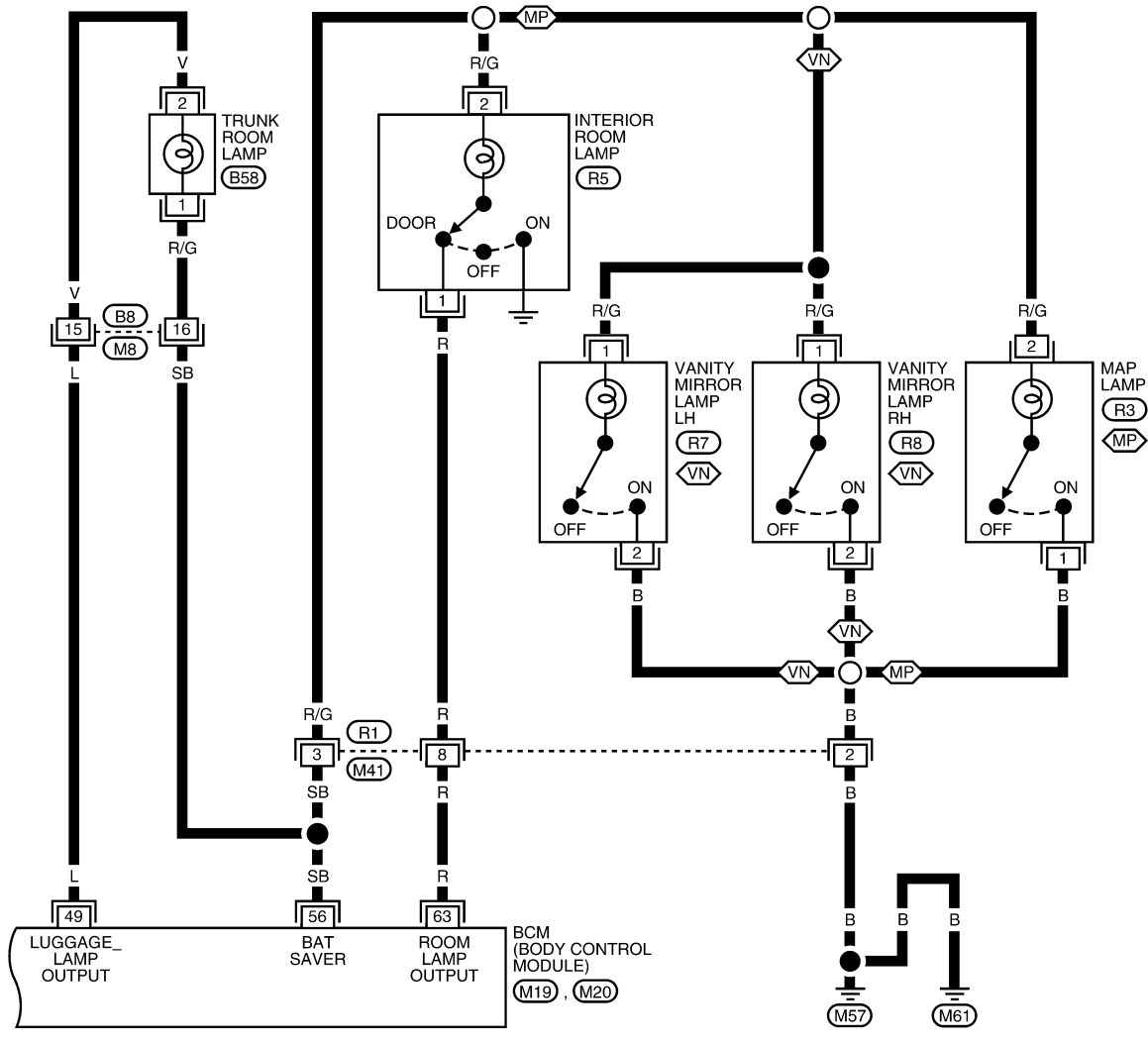

Terminal and Reference Value for BCM

Refer to [BCS-11, "Terminal and Reference Value for BCM"](#).

How to Proceed with Trouble Diagnosis

1. Confirm the symptom or customer complaint.
2. Understand operation description and function description. Refer to [LT-83, "System Description"](#).
3. Perform the preliminary check. Refer to [LT-92, "Preliminary Check"](#).

A
B
C
D
E
F
G
H
I
J
K
L
M
N
O
P

LT

INTERIOR ROOM LAMP

< SERVICE INFORMATION >

4. Check symptom and repair or replace the cause of the malfunction.
5. Does the interior room lamp operate normally? If YES, GO TO 6. If NO, GO TO 4.
6. Inspection end.

Preliminary Check

INFOID:000000004409205

CHECK POWER SUPPLY AND GROUND CIRCUIT FOR BCM

Refer to [BCS-14. "BCM Power Supply and Ground Circuit Inspection"](#) .

CONSULT-III Function (BCM)

INFOID:000000004409206

Refer to [BCS-15. "CONSULT-III Function \(BCM\)"](#)

WORK SUPPORT

Display Item List

Item	Description	CONSULT-III
SET I/L D-UNLCK INTCON	The 30 second operating function of the interior room lamps can be selected when the front door LH is released (unlocked).	ON/OFF
ROOM LAMP ON TIME SET	The time in order to escalate illumination can be adjusted when interior room lamps are turned on.	MODE 1 – 7
ROOM LAMP OFF TIME SET	The time in order to diminish illumination can be adjusted when interior room lamps are turned off.	MODE 1 – 7

Reference between “MODE” and “TIME” for “TURN ON/OFF”

MODE	1	2	3	4	5	6	7
Time (sec.)	0.5	1	2	3	4	5	0

DATA MONITOR

Display Item List

Monitor item	Contents
IGN ON SW	“ON/OFF” Displays “IGN position (ON)/OFF, ACC position (OFF)” judged from ignition switch signal.
KEY ON SW	“ON/OFF” Displays “Key inserted (ON)/key removed (OFF)” status judged from key switch signal.
DOOR SW - DR	“ON/OFF” Displays status of front door LH as judged from front door switch LH signal. (Door is open: ON/Door is closed: OFF)
DOOR SW - AS	“ON/OFF” Displays “Door open (ON)/Door closed (OFF)” status, determined from front door switch RH signal.
DOOR SW - RR	“ON/OFF” Displays “Door open (ON)/Door closed (OFF)” status, determined from rear door switch RH signal.
DOOR SW - RL	“ON/OFF” Displays “Door open (ON)/Door closed (OFF)” status, determined from rear door switch LH signal.
BACK DOOR SW	“ON/OFF” Displays “Door open (ON)/Door closed (OFF)” status, determined from rear door switch BACK signal.
KEY CYL LK-SW	“ON/OFF” Displays “Door locked (ON)” status, determined from key cylinder lock switch in front door LH.
KEY CYL UN-SW	“ON/OFF” Displays “door unlocked (OFF)” status, determined from key cylinder lock switch in front door LH.
CDL LOCK SW	“ON/OFF” Displays “Door locked (ON)/Door unlocked (OFF) status, determined from locking detection switch in the front door LH.
CDL UNLOCK SW	“ON/OFF” Displays “Door unlocked (OFF)” status, determined from locking detection switch in front door RH.
KEYLESS LOCK	“ON/OFF” Displays “Locked (ON)/Other (OFF)” status, determined from lock signal.
KEYLESS UNLOCK	“ON/OFF” Displays “Unlocked (ON)/Other (OFF)” status, determined from unlock signal.

INTERIOR ROOM LAMP

< SERVICE INFORMATION >

ACTIVE TEST

Display Item List

Test item	Description
INT LAMP	Interior room lamp can be operated by any ON-OFF operations.

Interior Room Lamp Control Does Not Operate

INFOID:000000004409207

1. CHECK EACH SWITCH

Select "BCM" on CONSULT-III. With "INT LAMP" data monitor, make sure switches listed in display item list turn ON-OFF linked with switch operation. Refer to [LT-92, "CONSULT-III Function \(BCM\)"](#) for switches and their functions.

OK or NG

- OK >> GO TO 2.
- NG >> Inspect malfunctioning switch system.

2. ACTIVE TEST

1. Select "BCM" on CONSULT-III. Select "INT LAMP" active test.
2. When room lamp switch is in DOOR position, make sure room lamp operates.

Room lamp should operate.

OK or NG

- OK >> Replace BCM. Refer to [BCS-17, "Removal and Installation of BCM"](#).
- NG >> GO TO 3.

3. CHECK ROOM LAMP INPUT VOLTAGE

1. Turn ignition switch OFF.
2. Check voltage between interior room lamp harness connector R5 terminal 2 and ground.

2 - Ground : Battery voltage should exist.

OK or NG

- OK >> GO TO 4.
- NG >> GO TO 5.

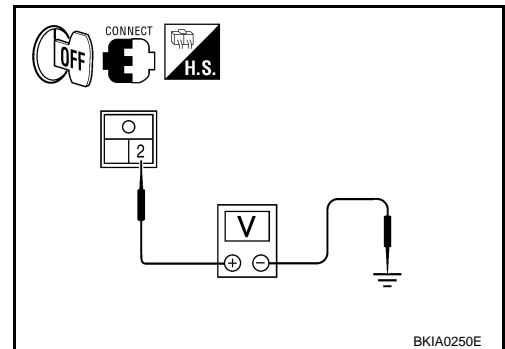

4. CHECK ROOM LAMP

1. Disconnect room lamp connector.
2. Check continuity between room lamp terminals.

Room lamp		Condition	Continuity
Terminal			
1	2	Room lamp switch is in DOOR position	Yes
		Room lamp switch is in OFF position	No

OK or NG

- OK >> GO TO 6.
- NG >> Check bulb. If OK, replace room lamp. Refer to [LT-94, "Removal and Installation"](#).

5. CHECK ROOM LAMP CIRCUIT

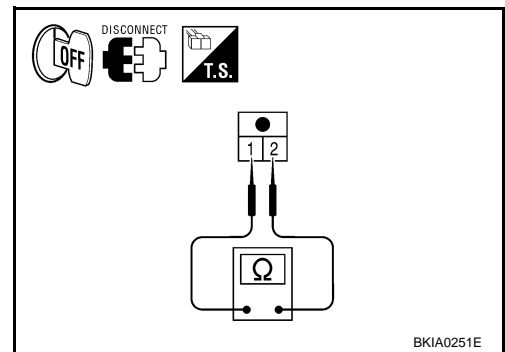

INTERIOR ROOM LAMP

< SERVICE INFORMATION >

1. Disconnect BCM and interior room lamp connectors.
2. Check continuity between BCM harness connector M20 (A) terminal 56 and room lamp harness connector R5 (B) terminal 2.

56 - 2 : Continuity should exist.

OK or NG

- OK >> GO TO 6.
NG >> Repair harness or connector.

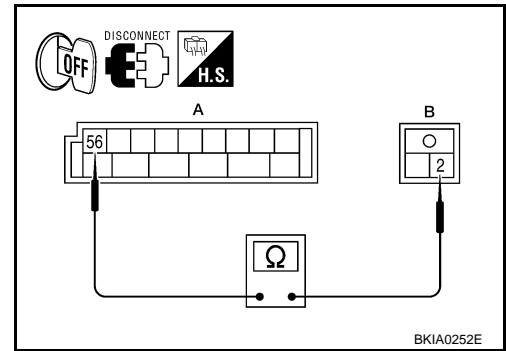

6. CHECK ROOM LAMP CIRCUIT

1. Disconnect BCM connector.
2. Check continuity between BCM harness connector M20 (A) terminal 63 and room lamp harness connector R5 (B) terminal 1.

63 - 1 : Continuity should exist.

OK or NG

- OK >> Replace BCM if interior lamp does not work after setting the connector again. Refer to [BCS-17. "Removal and Installation of BCM"](#).
- NG >> Repair harness or connector.

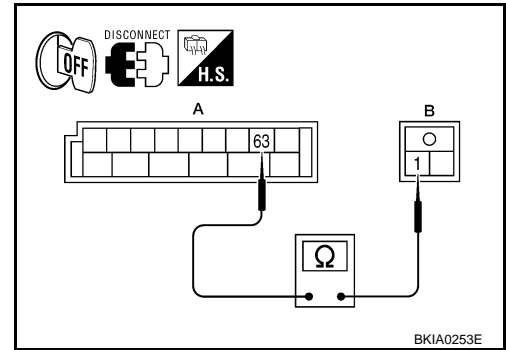

INFOID:000000004409208

Bulb Replacement

INTERIOR ROOM LAMP

Removal

1. Remove the interior lamp lens.
2. Push the interior lamp metal tab (B) and remove the bulb.
 - Interior lamp screws (A)

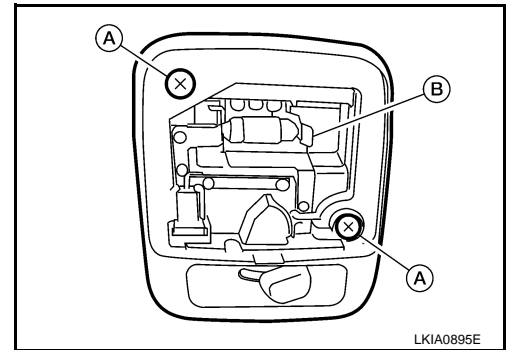

Installation

Installation is in the reverse order of removal.

Removal and Installation

INFOID:000000004409209

ROOM LAMP

Removal

INTERIOR ROOM LAMP

< SERVICE INFORMATION >

1. Remove the interior lamp lens and remove the interior room lamp screws (A).
 - Metal tab (B)
2. Disconnect the connector and remove the interior room lamp.

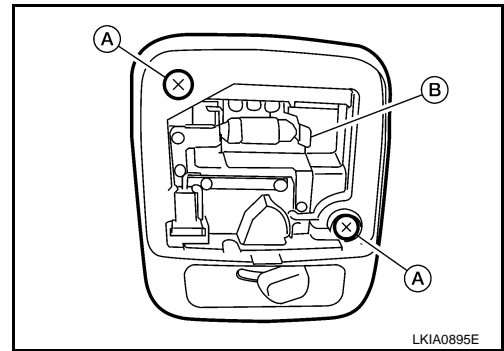

Installation

Installation is in the reverse order of removal.

A
B
C
D
E
F
G
H
I
J
LT
L
M
N
O
P

ILLUMINATION

< SERVICE INFORMATION >

ILLUMINATION

System Description

INFOID:000000004409210

The control of the illumination lamps operation is dependent upon the position of the lighting switch. When the lighting switch is placed in the 1ST or 2ND position, the BCM (body control module) receives input signal requesting the illumination lamps to illuminate. This input signal is communicated to IPDM E/R (intelligent power distribution module engine room) across CAN communication lines. CPU (central processing unit) located in the IPDM E/R controls the tail lamp relay coil. This relay, when energized, directs power to the illumination lamps, which then illuminate.

Power is supplied at all times

- to ignition relay, located in IPDM E/R,
- to tail lamp relay, located in IPDM E/R,
- through 15A fuse (No. 52, located in IPDM E/R) and
- through 20A fuse (No. 53, located in IPDM E/R)
- to CPU located in IPDM E/R,
- through 50A fusible link (letter j, located in fuse and fusible link box)
- to BCM terminal 70, and
- through 10A fuse [No. 21, located in fuse block (J/B)]
- to BCM terminal 57,
- through 10A fuse [No. 19, located in fuse block (J/B)]
- to combination meter terminal 1.

With the ignition switch in the ACC or ON position, power is supplied

- through 10A fuse [No. 6, located in fuse block (J/B)]
- to BCM terminal 11.

With the ignition switch in the ON or START position, power is supplied

- to ignition relay, located in IPDM E/R, and
- through 10A fuse [No. 12, located in fuse block (J/B)]
- to BCM terminal 38,
- through 10A fuse [No. 14, located in fuse block (J/B)]
- to combination meter terminal 2.

Ground is supplied

- to BCM terminal 67,
- to combination meter terminals 3, 21 and 22 and
- to glove box lamp terminal 2
- through grounds M57 and M61, and
- to IPDM E/R terminals 39 and 59
- through grounds E9, E15 (all models) and E24 (with MR20DE).

ILLUMINATION OPERATION BY LIGHTING SWITCH

With the lighting switch in the 1ST or 2ND position, BCM receives input signal requesting the illumination lamps to illuminate. This input signal is communicated to IPDM E/R across CAN communication lines. CPU located in the IPDM E/R controls the tail lamp relay coil, which, when energized, directs power

- through 10A fuse (No. 36, located in IPDM E/R)
- through IPDM E/R terminal 27
- to audio unit terminal 9,
- to front air control terminal 23,
- to hazard switch terminal 3
- to manual mode select switch terminal 4 (with QR25DE)
- to heated seat switches LH and RH terminal 5 (if equipped)
- through resistor 1 terminals 2 and 1
- through combination switch (spiral cable) terminals 34 and 14
- to steering wheel audio control switch (if equipped)
- to ASCD steering switch (if equipped),
- to steering shift switch (if equipped),
- to console lamp center terminal 1,
- to CVT device terminal 1 (with CVT),
- to Bluetooth ON indicator terminal 3 (with Bluetooth)
- to double meter terminal 11 (with double meter) and
- to glove box lamp terminal 1 (if equipped).

The illumination control switch controls illumination intensity by varying ground

ILLUMINATION

< SERVICE INFORMATION >

- through combination meter terminal 13
- to console lamp center terminal 2 and
- to CVT device terminal 2 (with CVT).
- to audio unit terminal 8
- to front air control terminal 24
- to hazard switch terminal 4,
- to manual mode select switch terminal 5 (with QR25DE)
- through combination switch (spiral cable) terminals 21 and 27
- to steering wheel audio control switch (if equipped)
- to ASCD steering switch (if equipped) and
- to steering shift switch (if equipped)
- to heated seat switches LH and RH terminal 6 (if equipped),
- through combination meter terminal 33 (with double meter)
- to double meter terminal 12.

With power and ground supplied, illumination lamps illuminate.

CAN Communication System Description

INFOID:000000004409211

Refer to [LAN-6, "System Description"](#).

A
B
C
D
E
F
G
H
I
J
LT
L
M
N
O
P

ILLUMINATION

< SERVICE INFORMATION >

Schematic

INFOID:0000000044092.12

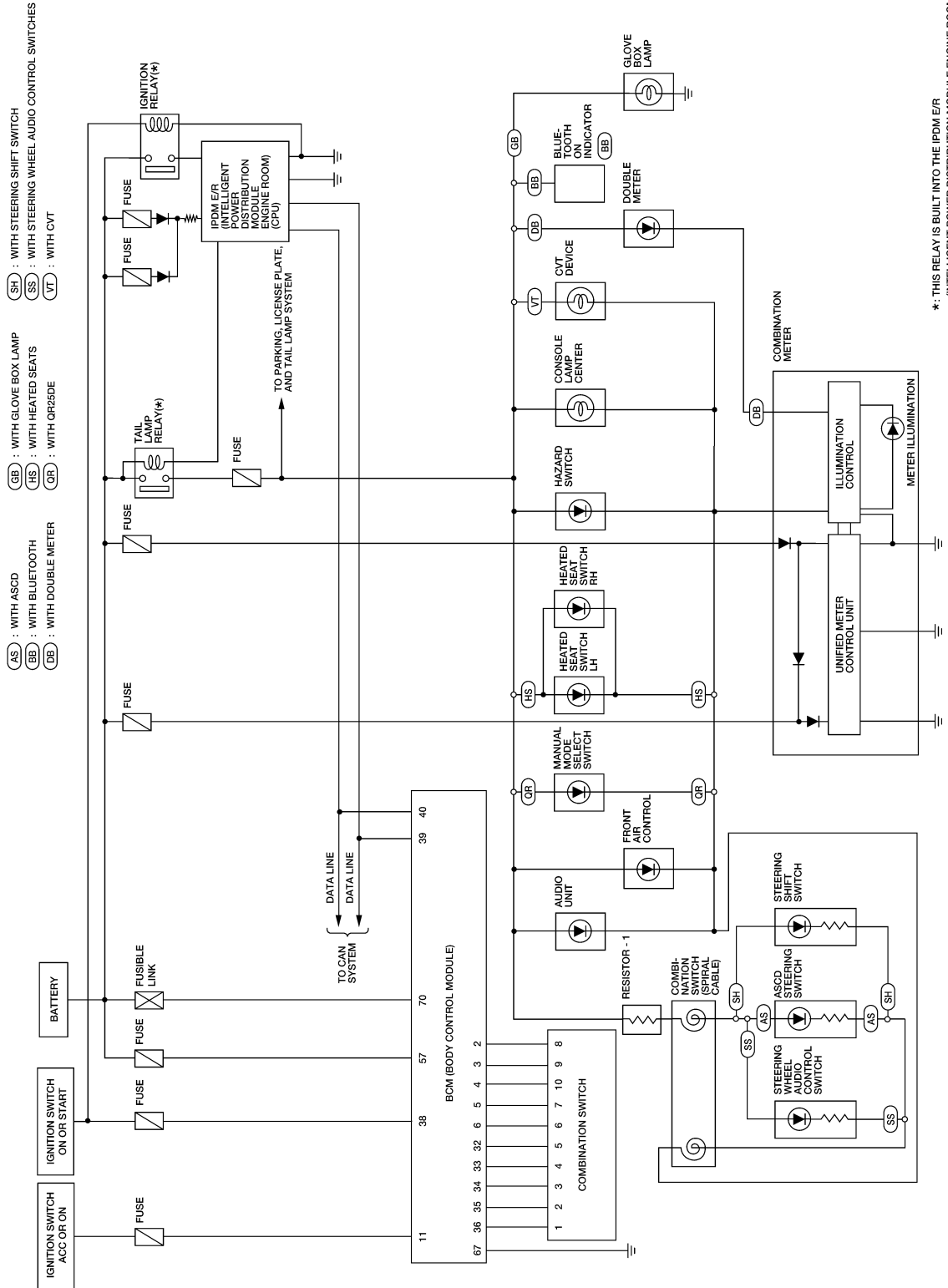

- (AS) : WITH ASCD
- (BE) : WITH BLUE-TOOTH
- (DE) : WITH DOUBLE METER
- (GB) : WITH GLOVE BOX LAMP
- (HS) : WITH HEATED SEATS
- (CR) : WITH QR25DE
- (SH) : WITH STEERING SHIFT SWITCH
- (SS) : WITH STEERING WHEEL AUDIO CONTROL SWITCHES
- (VT) : WITH CVT

*: THIS RELAY IS BUILT INTO THE IPDM E/R (INTELLIGENT POWER DISTRIBUTION MODULE ENGINE ROOM).

ABLWA0323GB

ILLUMINATION

< SERVICE INFORMATION >

Wiring Diagram - ILL -

INFOID:000000004409213

LT-ILL-01

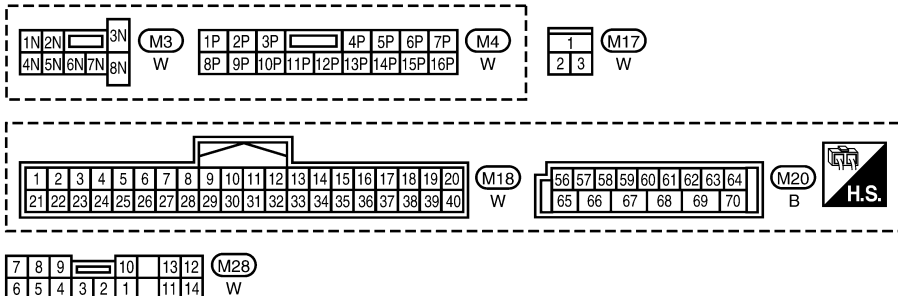
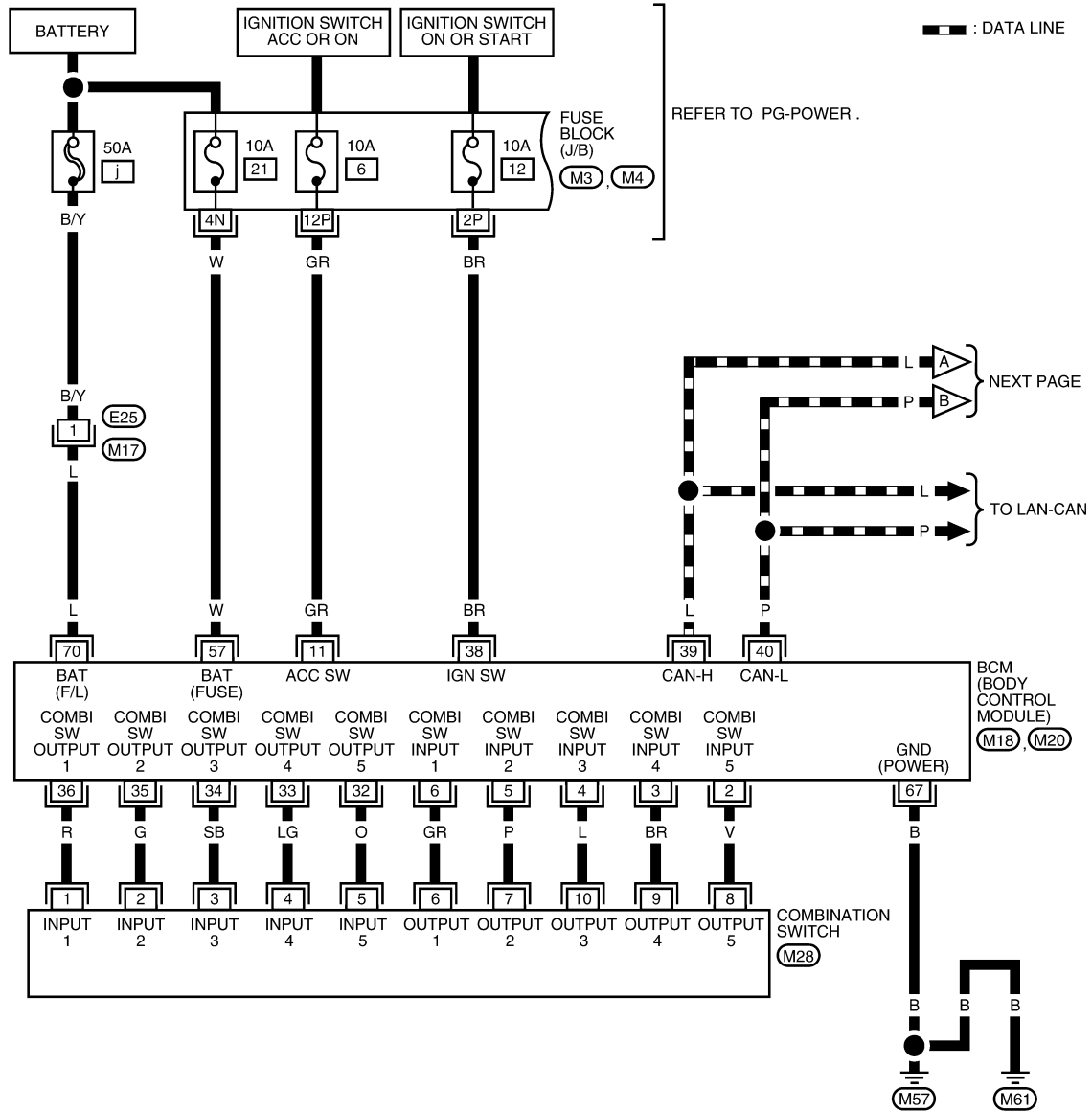

BKWA0809E

ILLUMINATION

< SERVICE INFORMATION >

LT-ILL-02

— : DATA LINE
 : WITH MR20DE

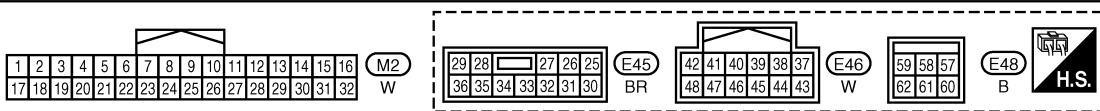
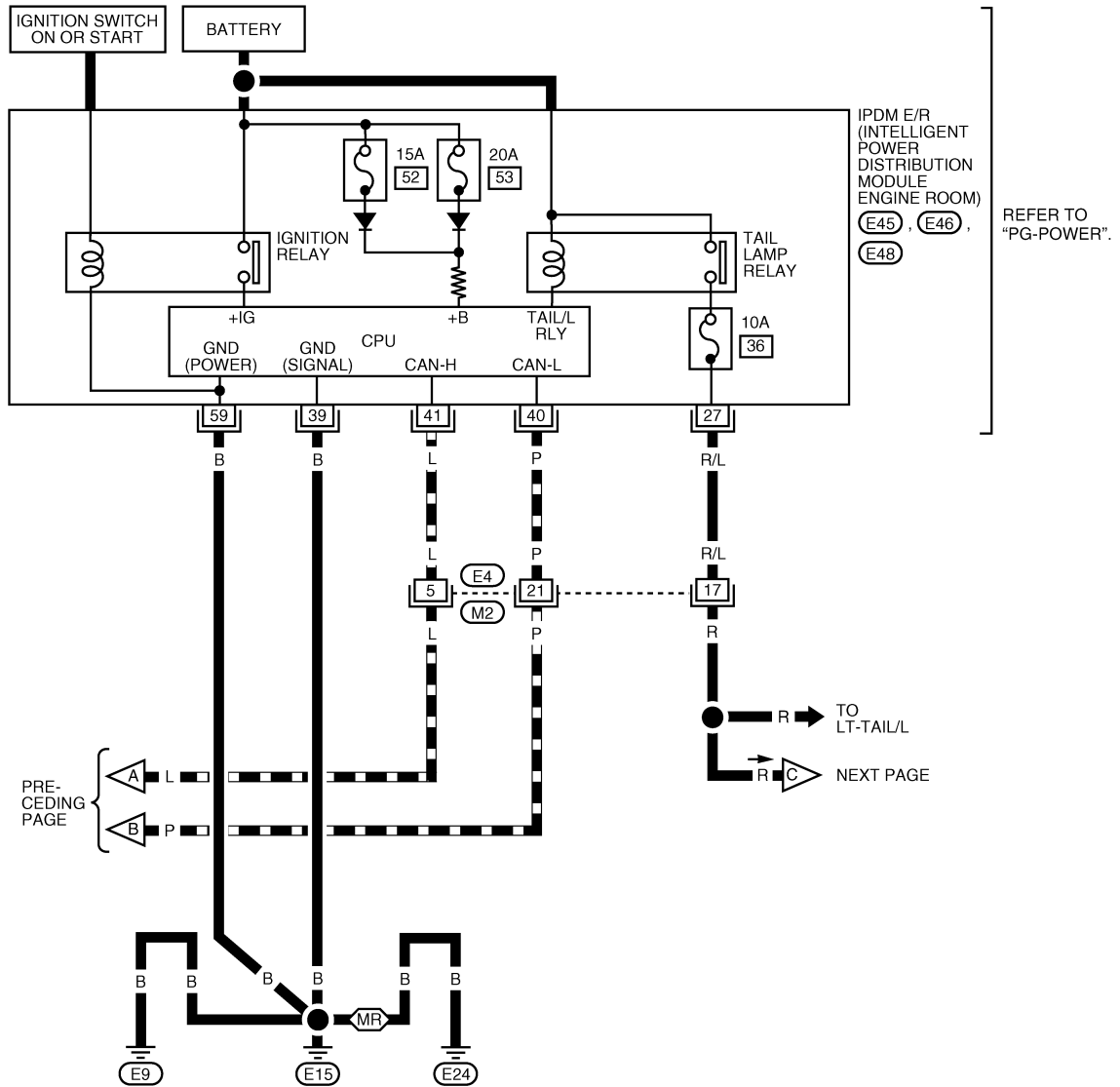

BKWA0841E

ILLUMINATION

< SERVICE INFORMATION >

LT-ILL-03

(DB) : WITH DOUBLE METER

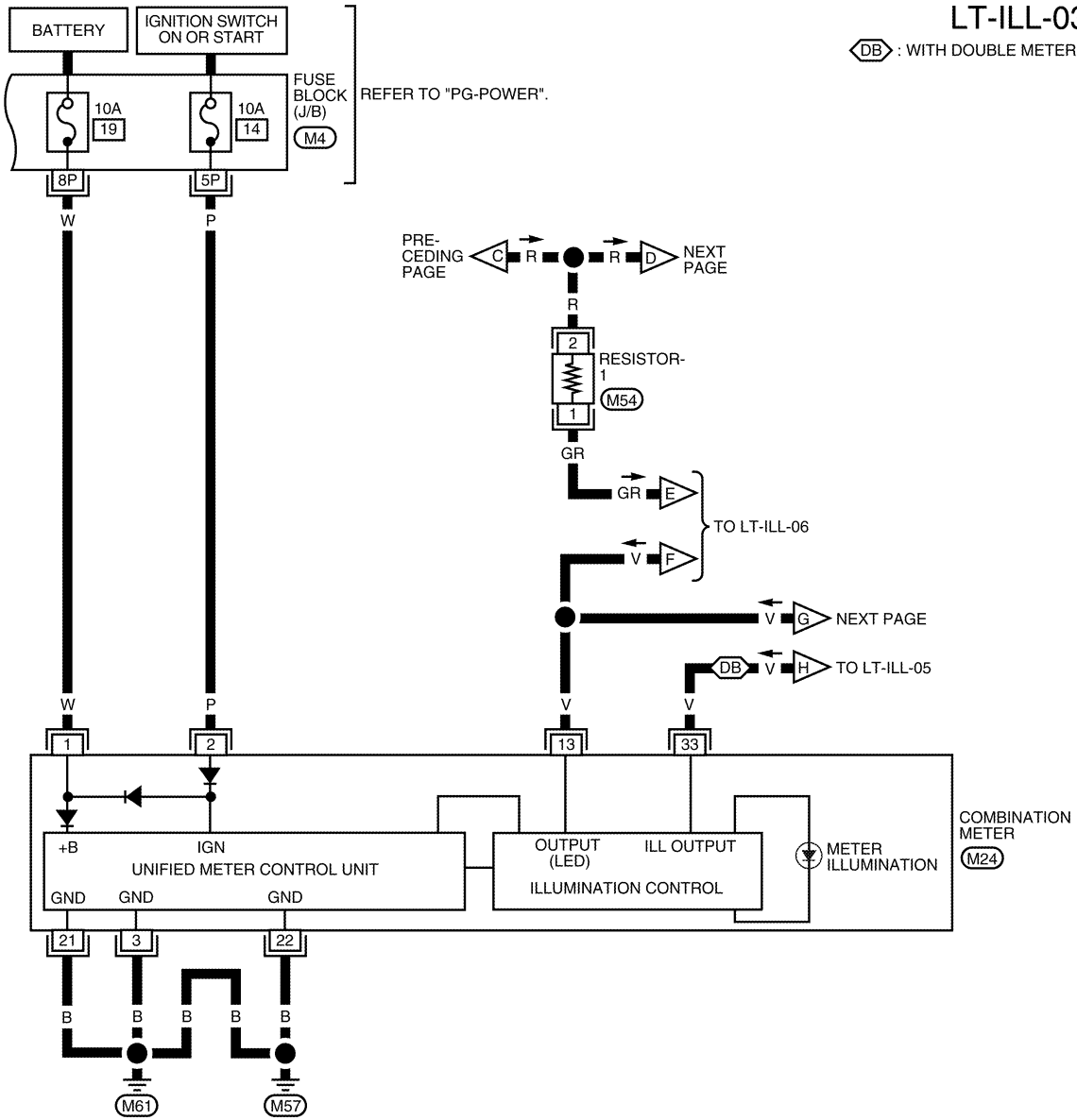

1P	2P	3P	4P	5P	6P	7P	(M4)	20	19	18	17	16	15	14	13	12	11	10	9	8	7	6	5	4	3	2	1	(M24)	2	1	(M54)
8P	9P	10P	11P	12P	13P	14P	15P	16P	W	40	39	38	37	36	35	34	33	32	31	30	29	28	27	26	25	24	23	22	21	W	B

ABLWA0324GB

ILLUMINATION

< SERVICE INFORMATION >

LT-ILL-04

HS : WITH HEATED SEATS
VT : WITH CVT

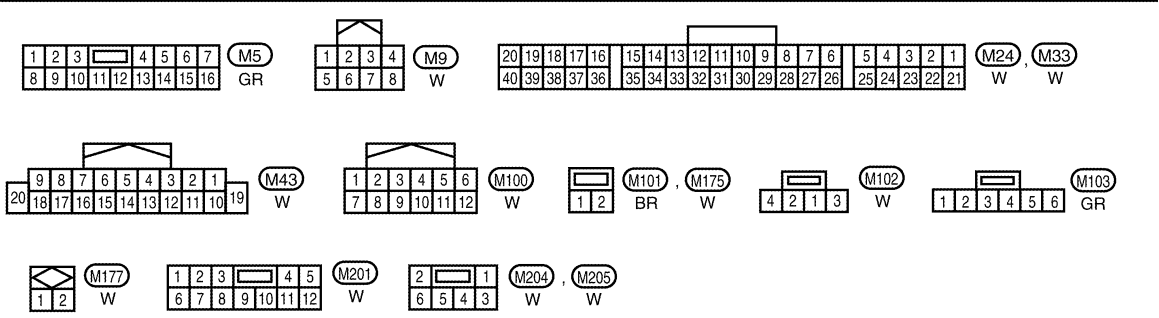
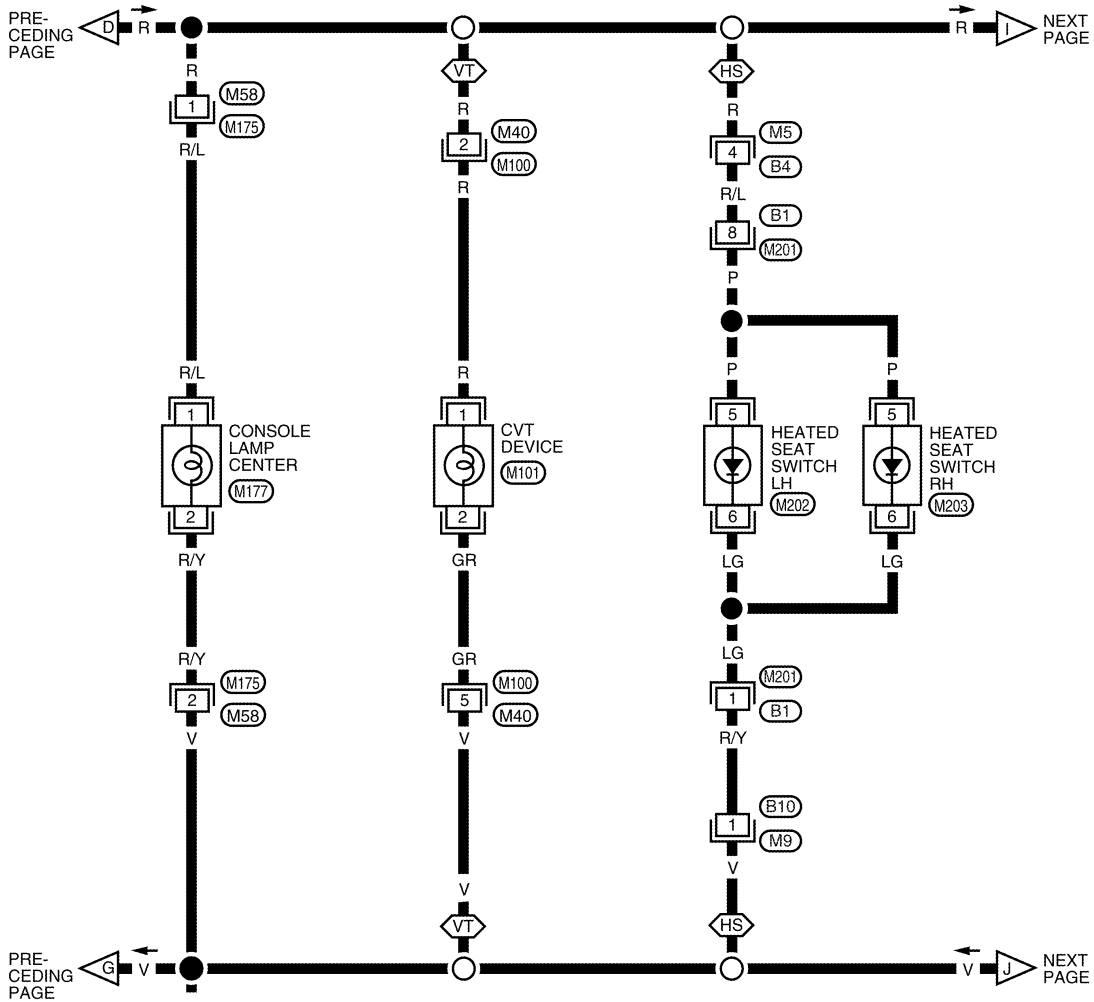

ABLWA0325GB

ILLUMINATION

< SERVICE INFORMATION >

LT-ILL-05

BB : WITH BLUETOOTH GB : WITH GLOVE BOX LAMP
DB : WITH DOUBLE METER QR : WITH QR25DE

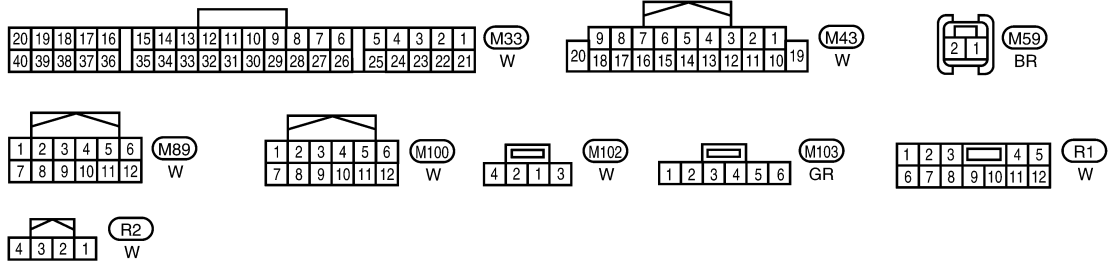
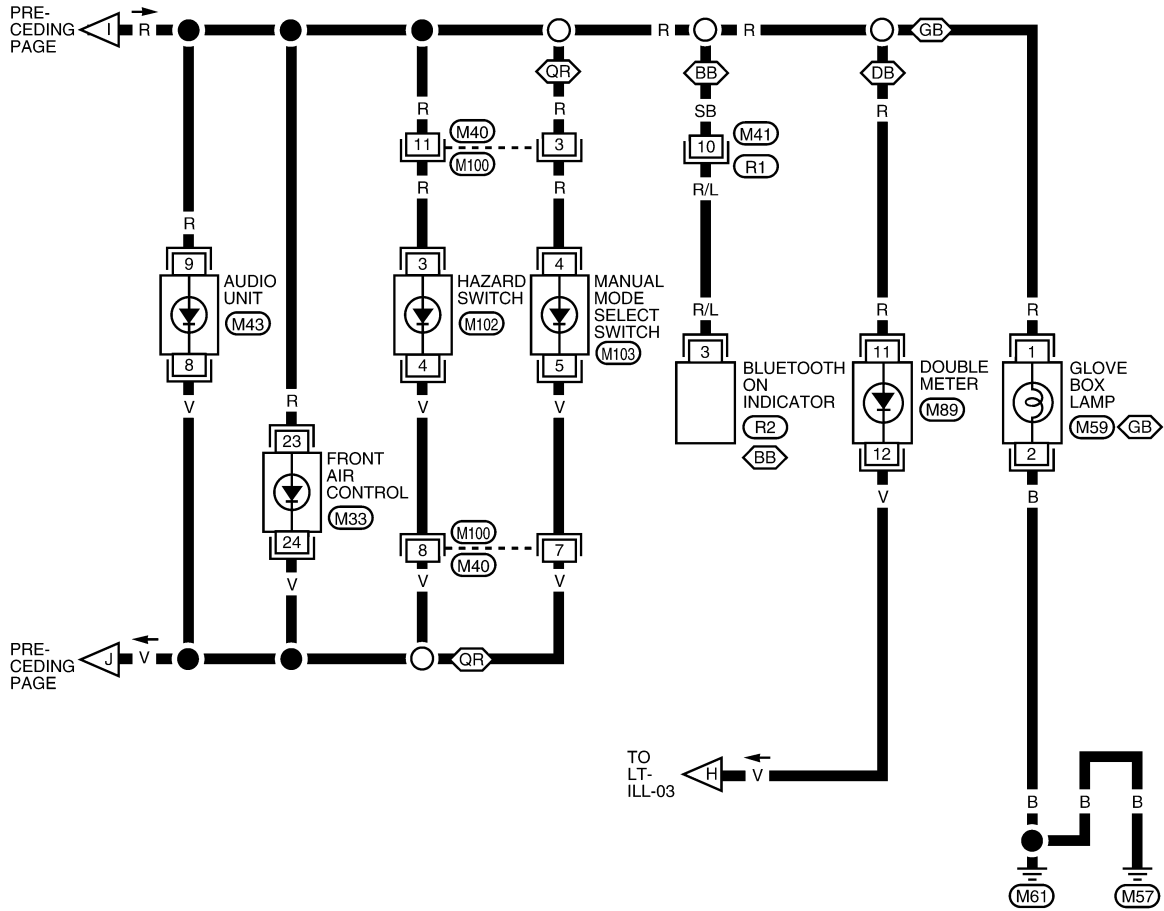

AALWA0069GB

ILLUMINATION

< SERVICE INFORMATION >

LT-ILL-06

- AS : WITH ASCD
- SH : WITH STEERING SHIFT SWITCH
- SS : WITH STEERING WHEEL AUDIO CONTROL SWITCHES

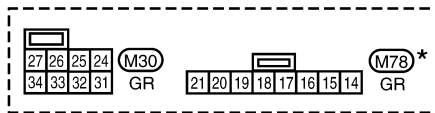
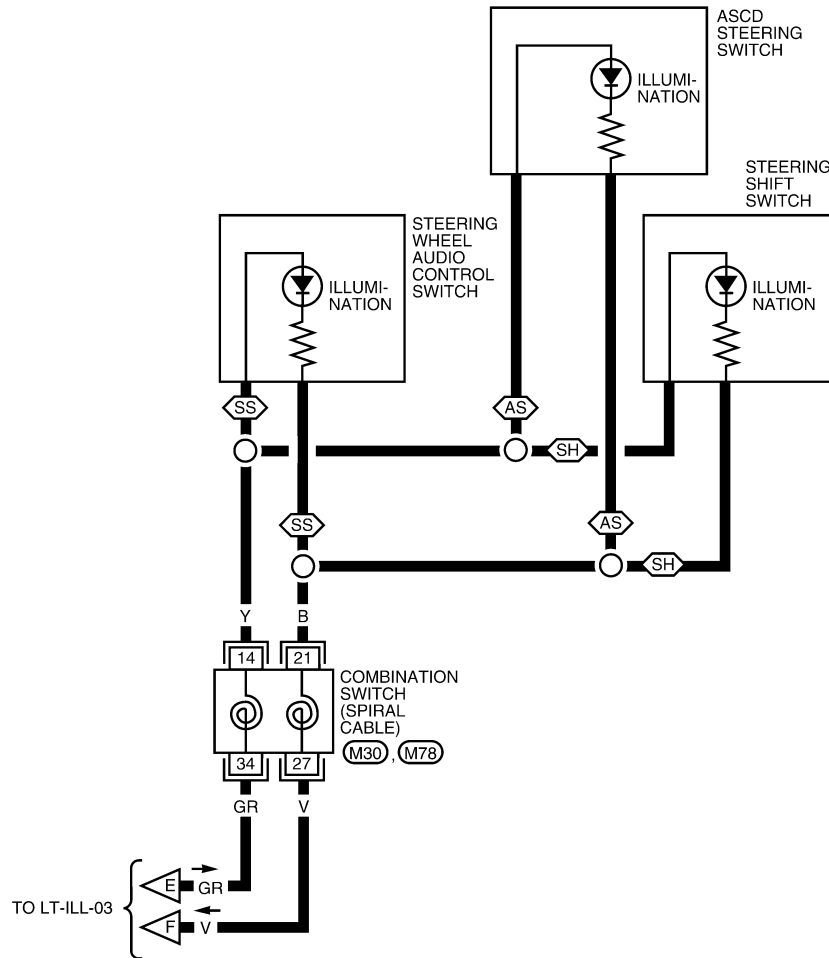

* : THIS CONNECTOR IS NOT SHOWN IN "HARNESS LAYOUT" OF PG SECTION.

ABLWA0343GB

INFOID:000000004409214

Bulb Replacement

GLOVE BOX LAMP

Removal

1. Remove glove box assembly. Refer to [IP-11, "Component Parts"](#).

ILLUMINATION

< SERVICE INFORMATION >

2. Turn bulb socket (1) counterclockwise and remove it.
3. Remove the bulb.

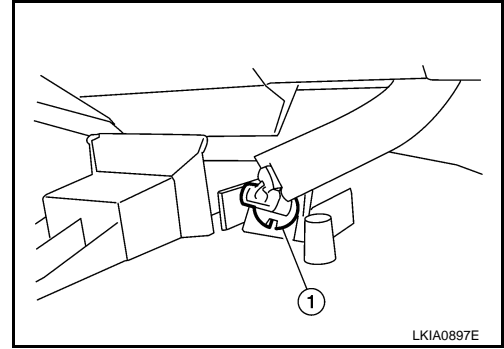

Installation

Installation is in the reverse order of removal.

CONSOLE LAMP

Removal

1. Remove the CVT or MT finisher. Refer to [IP-11, "Component Parts"](#).
2. Twist the console lamp socket and remove the bulb.

Installation

Installation is in the reverse order of removal.

Removal and Installation

INFOID:000000004409215

CONSOLE LAMP

The console lamp housing is part of the instrument upper cover (center) and is replaced as an assembly. Refer to [IP-11, "Component Parts"](#).

A
B
C
D
E
F
G
H
I
J
LT
L
M
N
O
P

BULB SPECIFICATIONS

< SERVICE INFORMATION >

BULB SPECIFICATIONS

Headlamp

INFOID:000000004409216

Item	Bulb No.*	Wattage (W)
High/Low (halogen type)	H13	65/55

*: Always check with the Parts Department for the latest parts information.

Exterior Lamp

INFOID:000000004409217

Item	Bulb No.*	Wattage (W)	
Front combination lamp	Turn signal lamp	3457 AK	27
	Parking (clearance) lamp	194	4
	Parking lamp	194	4
Rear combination lamp	Stop / tail lamp	3057K	27/7
	Turn signal lamp	3057K	27/7
	Back-up lamp	921	16
	Parking lamp	194	4
Front fog lamp	H11	55	
License plate lamp	W5W	5	
High-mounted stop lamp (parcel shelf mount)	921	16	
High-mounted stop lamp (rear air spoiler mount)	LED		

*: Always check with the Parts Department for the latest parts information.

Interior Lamp/Illumination

INFOID:000000004409218

Item	Wattage (W)*
Glove box lamp	1.4
Map lamp	8
Interior room lamp	8
Trunk room lamp	5

*: Always check with the Parts Department for the latest parts information.