

A
B

SECTION GW

GLASSES, WINDOW SYSTEM & MIRRORS

C

CONTENTS

D
E

<p>SERVICE INFORMATION 3</p> <p>PRECAUTIONS 3</p> <p style="padding-left: 20px;">Precaution for Supplemental Restraint System (SRS) "AIR BAG" and "SEAT BELT PRE-TENSIONER"3</p> <p style="padding-left: 20px;">Precaution for Procedure without Cowl Top Cover.....3</p> <p style="padding-left: 20px;">Handling for Adhesive and Primer3</p> <p>PREPARATION 4</p> <p style="padding-left: 20px;">Commercial Service Tool4</p> <p>SQUEAK AND RATTLE TROUBLE DIAGNOSIS 5</p> <p style="padding-left: 20px;">Work Flow5</p> <p style="padding-left: 20px;">Generic Squeak and Rattle Troubleshooting7</p> <p style="padding-left: 20px;">Diagnostic Worksheet9</p> <p>WINDSHIELD GLASS11</p> <p style="padding-left: 20px;">Removal and Installation 11</p> <p>REAR WINDOW GLASS AND MOLDING13</p> <p style="padding-left: 20px;">Removal and Installation 13</p> <p>POWER WINDOW SYSTEM15</p> <p style="padding-left: 20px;">Component Parts and Harness Connector Location 15</p> <p style="padding-left: 20px;">System Description 15</p> <p style="padding-left: 20px;">CAN Communication System Description 18</p> <p style="padding-left: 20px;">Schematic 19</p> <p style="padding-left: 20px;">Wiring Diagram - WINDOW -20</p> <p style="padding-left: 20px;">Main Power Window and Door Lock/Unlock Switch Harness Connector Terminal Layout25</p> <p style="padding-left: 20px;">Terminal and Reference Value for Main Power Window and Door Lock/Unlock Switch25</p> <p style="padding-left: 20px;">Terminal and Reference Value for BCM26</p> <p style="padding-left: 20px;">Work Flow26</p> <p style="padding-left: 20px;">CONSULT-III Function (BCM)26</p> <p style="padding-left: 20px;">Trouble Diagnosis Symptom Chart27</p> <p style="padding-left: 20px;">BCM Power Supply and Ground Circuit Inspection27</p>	<p style="padding-left: 20px;">Main Power Window and Door Lock/Unlock Switch Power Supply and Ground Circuit Inspection28</p> <p style="padding-left: 20px;">Power Window and Door Lock/Unlock Switch RH Power Supply Circuit Inspection29</p> <p style="padding-left: 20px;">Front Power Window LH Circuit Inspection29</p> <p style="padding-left: 20px;">Front Power Window RH Circuit Inspection (Power Window and Door Lock/Unlock Switch RH Operation)30</p> <p style="padding-left: 20px;">Front Power Window RH Circuit Inspection (Main Power Window and Door Lock/Unlock Switch Operation)33</p> <p style="padding-left: 20px;">Door Switch Check35</p> <p style="padding-left: 20px;">Rear Power Window LH Circuit Inspection (Rear Power Window Switch LH Operation)36</p> <p style="padding-left: 20px;">Rear Power Window LH Circuit Inspection (Main Power Window and Door Lock/Unlock Switch Operation)39</p> <p style="padding-left: 20px;">Rear Power Window RH Circuit Inspection (Rear Power Window Switch RH Operation)41</p> <p style="padding-left: 20px;">Rear Power Window RH Circuit Inspection (Main Power Window and Door Lock/Unlock Switch Operation)43</p> <p style="padding-left: 20px;">Encoder and Limit Switch Check45</p> <p>FRONT DOOR GLASS AND REGULATOR47</p> <p style="padding-left: 20px;">Removal and Installation47</p> <p style="padding-left: 20px;">Inspection after Installation49</p> <p style="padding-left: 20px;">Disassembly and Assembly50</p> <p>REAR DOOR GLASS AND REGULATOR51</p> <p style="padding-left: 20px;">Removal and Installation51</p> <p style="padding-left: 20px;">Disassembly and Assembly53</p> <p style="padding-left: 20px;">Inspection after Installation53</p> <p>REAR WINDOW DEFOGGER54</p> <p style="padding-left: 20px;">Component Parts and Harness Connector Location54</p> <p style="padding-left: 20px;">System Description54</p> <p style="padding-left: 20px;">CAN Communication System Description55</p> <p style="padding-left: 20px;">Schematic56</p>
---	--

GW

Wiring Diagram - DEF -	57	Filament Check	66
Terminal and Reference Value for BCM	60	Filament Repair	67
Terminal and Reference Value for IPDM E/R	60	DOOR MIRROR	69
Work Flow	60	Wiring Diagram - MIRROR -	69
CONSULT-III Function (BCM)	60	Removal and Installation	70
Trouble Diagnosis Symptom Chart	60	Disassembly and Assembly	70
BCM Power Supply and Ground Circuit Inspection		INSIDE MIRROR	72
.....	61	Removal and Installation	72
Rear Window Defogger Switch Circuit Inspection..	61		
Rear Window Defogger Circuit Inspection	62		
Door Mirror Defogger Circuit Inspection	64		

PRECAUTIONS

< SERVICE INFORMATION >

SERVICE INFORMATION

PRECAUTIONS

Precaution for Supplemental Restraint System (SRS) "AIR BAG" and "SEAT BELT PRE-TENSIONER"

INFOID:000000004409347

The Supplemental Restraint System such as "AIR BAG" and "SEAT BELT PRE-TENSIONER", used along with a front seat belt, helps to reduce the risk or severity of injury to the driver and front passenger for certain types of collision. This system includes seat belt switch inputs and dual stage front air bag modules. The SRS system uses the seat belt switches to determine the front air bag deployment, and may only deploy one front air bag, depending on the severity of a collision and whether the front occupants are belted or unbelted. Information necessary to service the system safely is included in the SRS and SB section of this Service Manual.

WARNING:

- To avoid rendering the SRS inoperative, which could increase the risk of personal injury or death in the event of a collision which would result in air bag inflation, all maintenance must be performed by an authorized NISSAN/INFINITI dealer.
- Improper maintenance, including incorrect removal and installation of the SRS, can lead to personal injury caused by unintentional activation of the system. For removal of Spiral Cable and Air Bag Module, see the SRS section.
- Do not use electrical test equipment on any circuit related to the SRS unless instructed to in this Service Manual. SRS wiring harnesses can be identified by yellow and/or orange harnesses or harness connectors.

Precaution for Procedure without Cowl Top Cover

INFOID:000000004409348

When performing the procedure after removing cowl top cover, cover the lower end of windshield.

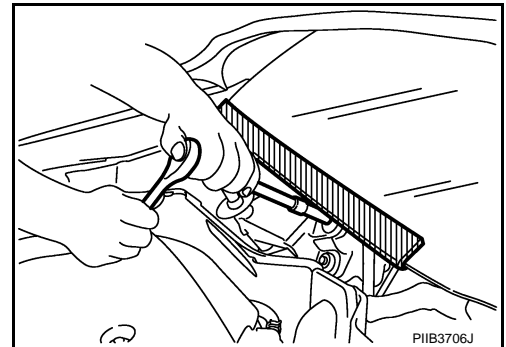

Handling for Adhesive and Primer

INFOID:000000004409349

- Do not use an adhesive which is past its usable date. Shelf life of the adhesive is limited to six months after the date of manufacture. Carefully adhere to the expiration or manufacture date printed on the box.
- Keep primers and adhesive in a cool, dry place. Ideally, they should be stored in a refrigerator.
- Open the seal of the primer and adhesive just before application. Discard the remainder after application.
- Before application, be sure to shake the primer container to stir the contents. If any floating material is found, do not use it.
- If any primer or adhesive contacts the skin, wipe it off with gasoline or equivalent and wash the skin with soap.
- When using primer and adhesive, always observe the precautions in the instruction manual.

PREPARATION

< SERVICE INFORMATION >

PREPARATION

Commercial Service Tool

INFOID:000000004409350

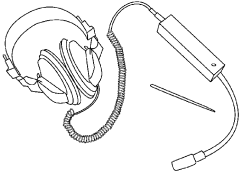
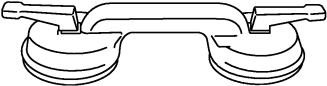
Tool name	Description
<p data-bbox="191 457 302 485">Engine ear</p>  <p data-bbox="802 569 867 590">SIA0995E</p>	<p data-bbox="998 457 1182 485">Locating the noise</p>
<p data-bbox="191 709 318 737">Suction lifter</p>  <p data-bbox="802 821 867 842">PIB1805J</p>	<p data-bbox="998 709 1211 737">Holding of door glass</p>

SQUEAK AND RATTLE TROUBLE DIAGNOSIS

< SERVICE INFORMATION >

SQUEAK AND RATTLE TROUBLE DIAGNOSIS

Work Flow

INFOID:000000004409351

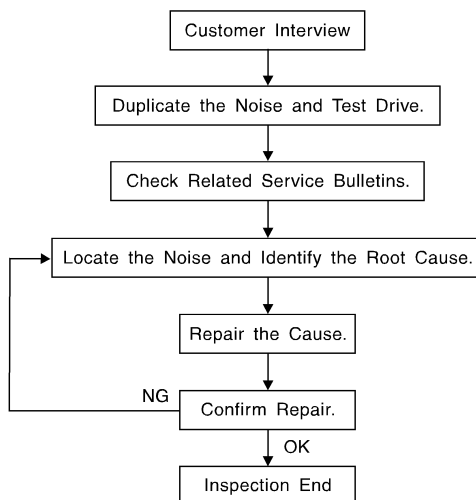

SBT842

CUSTOMER INTERVIEW

Interview the customer if possible, to determine the conditions that exist when the noise occurs. Use the Diagnostic Worksheet during the interview to document the facts and conditions when the noise occurs and any customer's comments; refer to [GW-7, "Generic Squeak and Rattle Troubleshooting"](#). This information is necessary to duplicate the conditions that exist when the noise occurs.

- The customer may not be able to provide a detailed description or the location of the noise. Attempt to obtain all the facts and conditions that exist when the noise occurs (or does not occur).
- If there is more than one noise in the vehicle, be sure to diagnose and repair the noise that the customer is concerned about. This can be accomplished by test driving the vehicle with the customer.
- After identifying the type of noise, isolate the noise in terms of its characteristics. The noise characteristics are provided so the customer, service adviser and technician are all speaking the same language when defining the noise.
- Squeak —(Like tennis shoes on a clean floor)
Squeak characteristics include the light contact/fast movement/brought on by road conditions/hard surfaces = higher pitch noise/softer surfaces = lower pitch noises/edge to surface = chirping.
- Creak—(Like walking on an old wooden floor)
Creak characteristics include firm contact/slow movement/twisting with a rotational movement/pitch dependent on materials/often brought on by activity.
- Rattle—(Like shaking a baby rattle)
Rattle characteristics include the fast repeated contact/vibration or similar movement/loose parts/missing clip or fastener/incorrect clearance.
- Knock —(Like a knock on a door)
Knock characteristics include hollow sounding/sometimes repeating/often brought on by driver action.
- Tick—(Like a clock second hand)
Tick characteristics include gentle contacting of light materials/loose components/can be caused by driver action or road conditions.
- Thump—(Heavy, muffled knock noise)
Thump characteristics include softer knock/dead sound often brought on by activity.
- Buzz—(Like a bumble bee)
Buzz characteristics include high frequency rattle/firm contact.
- Often the degree of acceptable noise level will vary depending upon the person. A noise that you may judge as acceptable may be very irritating to the customer.
- Weather conditions, especially humidity and temperature, may have a great effect on noise level.

DUPLICATE THE NOISE AND TEST DRIVE

If possible, drive the vehicle with the customer until the noise is duplicated. Note any additional information on the Diagnostic Worksheet regarding the conditions or location of the noise. This information can be used to duplicate the same conditions when you confirm the repair.

SQUEAK AND RATTLE TROUBLE DIAGNOSIS

< SERVICE INFORMATION >

If the noise can be duplicated easily during the test drive, to help identify the source of the noise, try to duplicate the noise with the vehicle stopped by doing one or all of the following:

- 1) Close a door.
 - 2) Tap or push/pull around the area where the noise appears to be coming from.
 - 3) Rev the engine.
 - 4) Use a floor jack to recreate vehicle "twist".
 - 5) At idle, apply engine load (electrical load, half-clutch on M/T model, drive position on A/T model).
 - 6) Raise the vehicle on a hoist and hit a tire with a rubber hammer.
- Drive the vehicle and attempt to duplicate the conditions the customer states exist when the noise occurs.
 - If it is difficult to duplicate the noise, drive the vehicle slowly on an undulating or rough road to stress the vehicle body.

CHECK RELATED SERVICE BULLETINS

After verifying the customer concern or symptom, check ASIST for Technical Service Bulletins (TSBs) related to that concern or symptom.

If a TSB relates to the symptom, follow the procedure to repair the noise.

LOCATE THE NOISE AND IDENTIFY THE ROOT CAUSE

1. Narrow down the noise to a general area. To help pinpoint the source of the noise, use a listening tool (Chassis Ear: J-39570, Engine Ear: J-39565 and mechanic's stethoscope).
2. Narrow down the noise to a more specific area and identify the cause of the noise by:
 - removing the components in the area that you suspect the noise is coming from.
Do not use too much force when removing clips and fasteners, otherwise clips and fasteners can be broken or lost during the repair, resulting in the creation of new noise.
 - tapping or pushing/pulling the component that you suspect is causing the noise.
Do not tap or push/pull the component with excessive force, otherwise the noise will be eliminated only temporarily.
 - feeling for a vibration with your hand by touching the component(s) that you suspect is (are) causing the noise.
 - placing a piece of paper between components that you suspect are causing the noise.
 - looking for loose components and contact marks.
Refer to [GW-7. "Generic Squeak and Rattle Troubleshooting"](#).

REPAIR THE CAUSE

- If the cause is a loose component, tighten the component securely.
- If the cause is insufficient clearance between components:
 - separate components by repositioning or loosening and retightening the component, if possible.
 - insulate components with a suitable insulator such as urethane pads, foam blocks, felt cloth tape or urethane tape. A NISSAN Squeak and Rattle Kit (J-43980) is available through your authorized NISSAN Parts Department.

CAUTION:

Do not use excessive force as many components are constructed of plastic and may be damaged.

Always check with the Parts Department for the latest parts information.

The following materials are contained in the NISSAN Squeak and Rattle Kit (J-43980). Each item can be ordered separately as needed.

URETHANE PADS [1.5 mm (0.059 in) thick]

Insulates connectors, harness, etc.

76268-9E005: 100×135 mm (3.94×5.31 in)/76884-71L01: 60×85 mm (2.36×3.35 in)/76884-71L02: 15×25 mm (0.59×0.98 in)

INSULATOR (Foam blocks)

Insulates components from contact. Can be used to fill space behind a panel.

73982-9E000: 45 mm (1.77 in) thick, 50×50 mm (1.97×1.97 in)/73982-50Y00: 10 mm (0.39 in) thick, 50×50 mm (1.97×1.97 in)

INSULATOR (Light foam block)

80845-71L00: 30 mm (1.18 in) thick, 30×50 mm (1.18×1.97 in)

FELT CLOTH TAPE

Used to insulate where movement does not occur. Ideal for instrument panel applications.

68370-4B000: 15×25 mm (0.59×0.98 in) pad/68239-13E00: 5 mm (0.20 in) wide tape roll. The following materials not found in the kit can also be used to repair squeaks and rattles.

UHMW (TEFLON) TAPE

Insulates where slight movement is present. Ideal for instrument panel applications.

SQUEAK AND RATTLE TROUBLE DIAGNOSIS

< SERVICE INFORMATION >

SILICONE GREASE

Used instead of UHMW tape that will be visible or not fit.

Note: Will only last a few months.

SILICONE SPRAY

Use when grease cannot be applied.

DUCT TAPE

Use to eliminate movement.

CONFIRM THE REPAIR

Confirm that the cause of a noise is repaired by test driving the vehicle. Operate the vehicle under the same conditions as when the noise originally occurred. Refer to the notes on the Diagnostic Worksheet.

Generic Squeak and Rattle Troubleshooting

INFOID:000000004409352

Refer to Table of Contents for specific component removal and installation information.

INSTRUMENT PANEL

Most incidents are caused by contact and movement between:

1. The cluster lid A and instrument panel
2. Acrylic lens and combination meter housing
3. Instrument panel to front pillar garnish
4. Instrument panel to windshield
5. Instrument panel mounting pins
6. Wiring harnesses behind the combination meter
7. A/C defroster duct and duct joint

These incidents can usually be located by tapping or moving the components to duplicate the noise or by pressing on the components while driving to stop the noise. Most of these incidents can be repaired by applying felt cloth tape or silicone spray (in hard to reach areas). Urethane pads can be used to insulate wiring harness.

CAUTION:

Do not use silicone spray to isolate a squeak or rattle. If you saturate the area with silicone, you will not be able to recheck the repair.

CENTER CONSOLE

Components to pay attention to include:

1. Shifter assembly cover to finisher
2. A/C control unit and cluster lid C
3. Wiring harnesses behind audio and A/C control unit

The instrument panel repair and isolation procedures also apply to the center console.

DOORS

Pay attention to the:

1. Finisher and inner panel making a slapping noise
2. Inside handle escutcheon to door finisher
3. Wiring harnesses tapping
4. Door striker out of alignment causing a popping noise on starts and stops

Tapping or moving the components or pressing on them while driving to duplicate the conditions can isolate many of these incidents. You can usually insulate the areas with felt cloth tape or insulator foam blocks from the NISSAN Squeak and Rattle Kit (J-43980) to repair the noise.

TRUNK

Trunk noises are often caused by a loose jack or loose items put into the trunk by the owner.

In addition look for:

1. Trunk lid bumpers out of adjustment
2. Trunk lid striker out of adjustment
3. The trunk lid torsion bars knocking together
4. A loose license plate or bracket

A

B

C

D

E

F

G

H

GW

J

K

L

M

N

O

P

SQUEAK AND RATTLE TROUBLE DIAGNOSIS

< SERVICE INFORMATION >

Most of these incidents can be repaired by adjusting, securing or insulating the item(s) or component(s) causing the noise.

SUNROOF/HEADLINING

Noises in the sunroof/headlining area can often be traced to one of the following:

1. Sunroof lid, rail, linkage or seals making a rattle or light knocking noise
2. Sun visor shaft shaking in the holder
3. Front or rear windshield touching headliner and squeaking

Again, pressing on the components to stop the noise while duplicating the conditions can isolate most of these incidents. Repairs usually consist of insulating with felt cloth tape.

OVERHEAD CONSOLE (FRONT AND REAR)

Overhead console noises are often caused by the console panel clips not being engaged correctly. Most of these incidents are repaired by pushing up on the console at the clip locations until the clips engage.

In addition look for:

1. Loose harness or harness connectors.
2. Front console map/reading lamp lense loose.
3. Loose screws at console attachment points.

SEATS

When isolating seat noise it's important to note the position the seat is in and the load placed on the seat when the noise is present. These conditions should be duplicated when verifying and isolating the cause of the noise.

Cause of seat noise include:

1. Headrest rods and holder
2. A squeak between the seat pad cushion and frame
3. The rear seatback lock and bracket

These noises can be isolated by moving or pressing on the suspected components while duplicating the conditions under which the noise occurs. Most of these incidents can be repaired by repositioning the component or applying urethane tape to the contact area.

UNDERHOOD

Some interior noise may be caused by components under the hood or on the engine wall. The noise is then transmitted into the passenger compartment.

Causes of transmitted underhood noise include:

1. Any component mounted to the engine wall
2. Components that pass through the engine wall
3. Engine wall mounts and connectors
4. Loose radiator mounting pins
5. Hood bumpers out of adjustment
6. Hood striker out of adjustment

These noises can be difficult to isolate since they cannot be reached from the interior of the vehicle. The best method is to secure, move or insulate one component at a time and test drive the vehicle. Also, engine RPM or load can be changed to isolate the noise. Repairs can usually be made by moving, adjusting, securing, or insulating the component causing the noise.

SQUEAK AND RATTLE TROUBLE DIAGNOSIS

< SERVICE INFORMATION >

Diagnostic Worksheet

INFOID:000000004409353

Dear Customer:

We are concerned about your satisfaction with your vehicle. Repairing a squeak or rattle sometimes can be very difficult. To help us fix your vehicle right the first time, please take a moment to note the area of the vehicle where the squeak or rattle occurs and under what conditions. You may be asked to take a test drive with a service advisor or technician to ensure we confirm the noise you are hearing.

SQUEAK & RATTLE DIAGNOSTIC WORKSHEET

I. WHERE DOES THE NOISE COME FROM? (circle the area of the vehicle)

The illustrations are for reference only, and may not reflect the actual configuration of your vehicle.

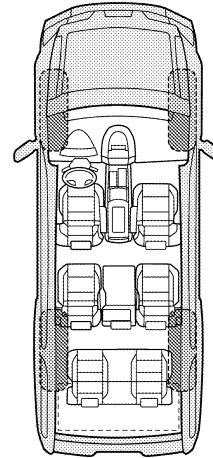
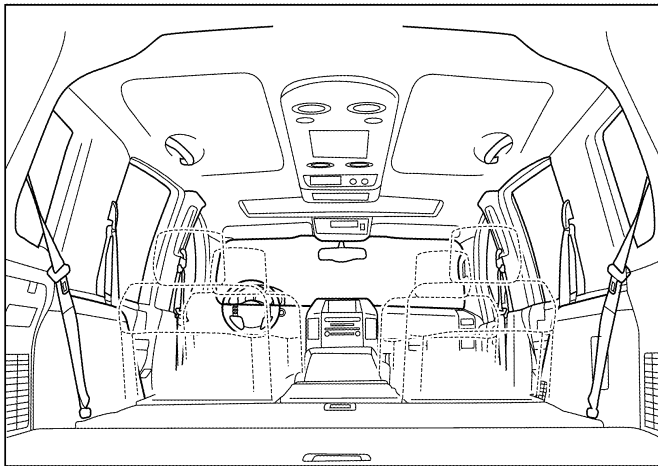
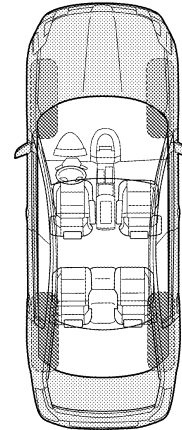
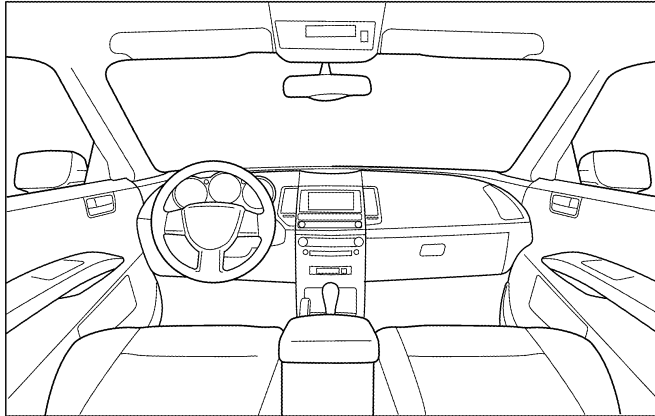

Continue to page 2 of the worksheet and briefly describe the location of the noise or rattle. In addition, please indicate the conditions which are present when the noise occurs.

A
B
C
D
E
F
G
H
GW
J
K
L
M
N
O
P

SQUEAK AND RATTLE TROUBLE DIAGNOSIS

< SERVICE INFORMATION >

SQUEAK & RATTLE DIAGNOSTIC WORKSHEET - page 2

Briefly describe the location where the noise occurs:

II. WHEN DOES IT OCCUR? (please check the boxes that apply)

- | | |
|---|--|
| <input type="checkbox"/> Anytime | <input type="checkbox"/> After sitting out in the rain |
| <input type="checkbox"/> 1st time in the morning | <input type="checkbox"/> When it is raining or wet |
| <input type="checkbox"/> Only when it is cold outside | <input type="checkbox"/> Dry or dusty conditions |
| <input type="checkbox"/> Only when it is hot outside | <input type="checkbox"/> Other: |

III. WHEN DRIVING:

- Through driveways
- Over rough roads
- Over speed bumps
- Only about ____ mph
- On acceleration
- Coming to a stop
- On turns: left, right or either (circle)
- With passengers or cargo
- Other: _____
- After driving ____ miles or ____ minutes

IV. WHAT TYPE OF NOISE

- Squeak (like tennis shoes on a clean floor)
- Creak (like walking on an old wooden floor)
- Rattle (like shaking a baby rattle)
- Knock (like a knock at the door)
- Tick (like a clock second hand)
- Thump (heavy muffled knock noise)
- Buzz (like a bumble bee)

TO BE COMPLETED BY DEALERSHIP PERSONNEL

Test Drive Notes:

	YES	NO	Initials of person performing
Vehicle test driven with customer	<input type="checkbox"/>	<input type="checkbox"/>	_____
- Noise verified on test drive	<input type="checkbox"/>	<input type="checkbox"/>	_____
- Noise source located and repaired	<input type="checkbox"/>	<input type="checkbox"/>	_____
- Follow up test drive performed to confirm repair	<input type="checkbox"/>	<input type="checkbox"/>	_____

VIN: _____ Customer Name _____

W.O.# _____ Date: _____

This form must be attached to Work Order

LAI0071E

WINDSHIELD GLASS

< SERVICE INFORMATION >

WINDSHIELD GLASS

Removal and Installation

INFOID:000000004409354

SEC. 720

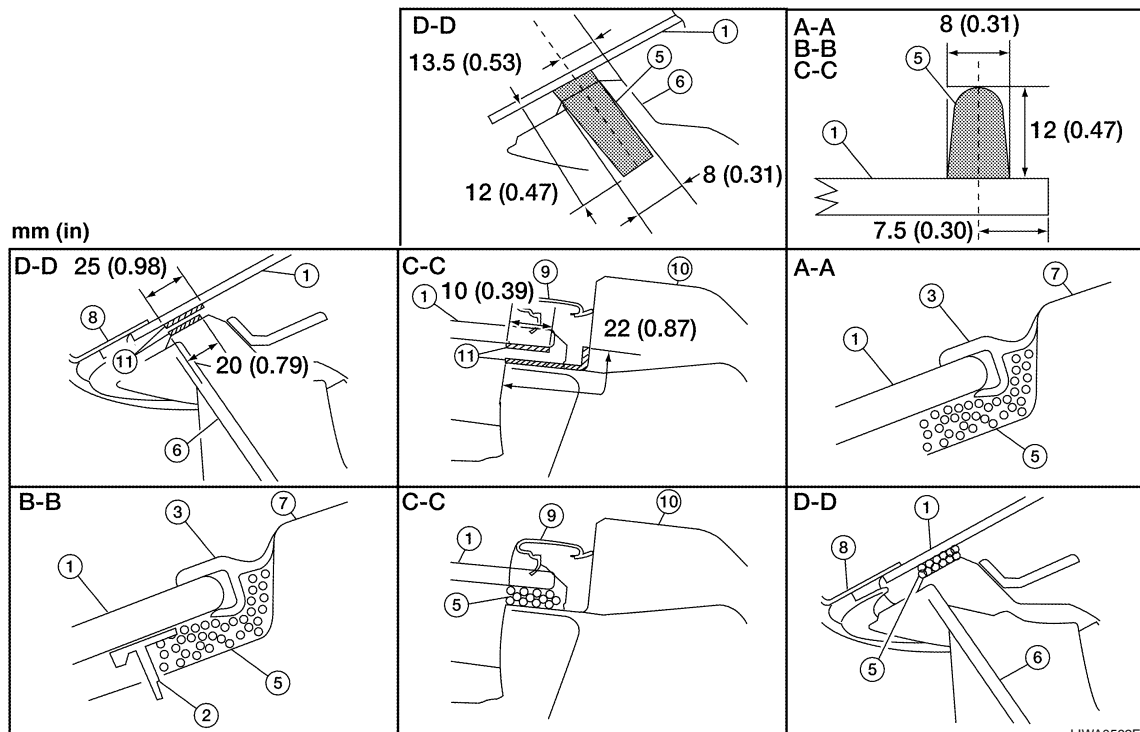
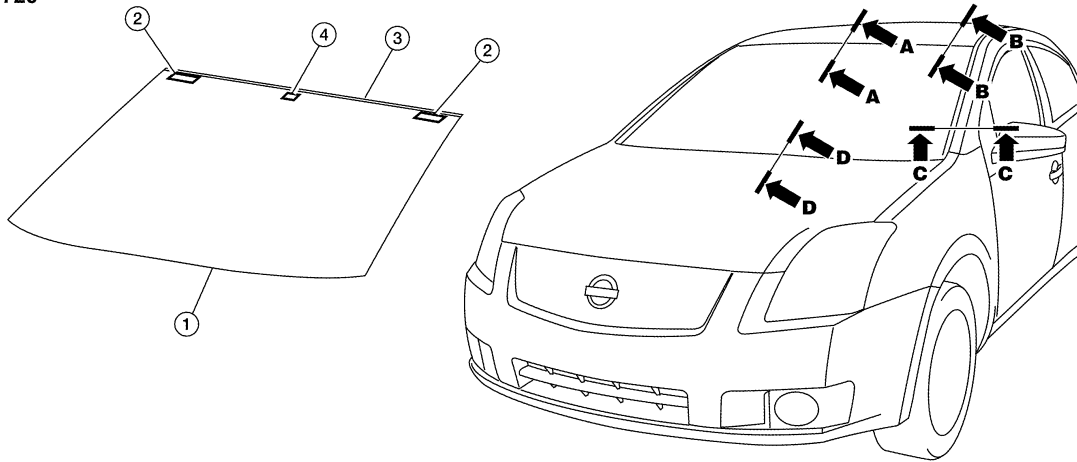

- | | | |
|------------------------------|-------------------|-----------------------|
| 1. Windshield glass assembly | 2. Spacer | 3. Windshield molding |
| 4. Mirror base | 5. Adhesive | 6. Cowl top center |
| 7. Roof panel outer | 8. Cowl top cover | 9. Roof side molding |
| 10. Front pillar outer panel | 11. Primer | |

REMOVAL

- Partially remove the headlining (front edge). Refer to [EI-40. "Removal and Installation"](#).
- Remove the front wiper arms. Refer to [WW-18. "Removal and Installation of Front Wiper Arms"](#).
- Remove the cowl top cover. Refer to [EI-19. "Removal and Installation"](#).
- Apply protective tape around the windshield glass to protect the painted surface from damage.

A
B
C
D
E
F
G
H
J
K
L
M
N
O
P

GW

WINDSHIELD GLASS

< SERVICE INFORMATION >

- After removing windshield upper molding, remove glass using piano wire or power cutting tool (A) and an inflatable pump bag (B).

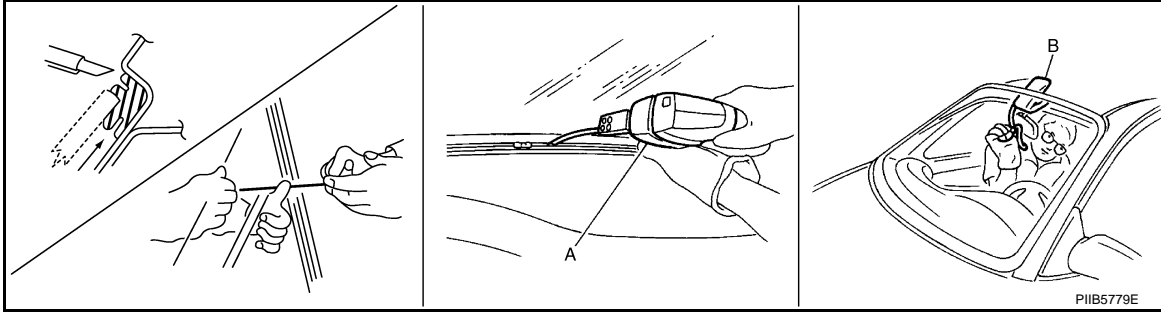

- If a windshield glass is to be reused, mark the body and the glass with mating marks.

WARNING:

When cutting the glass from the vehicle, always wear safety glasses and heavy gloves to help prevent glass splinters from entering your eyes or cutting your hands.

CAUTION:

- When a windshield glass is to be reused, do not use a cutting knife or power cutting tool.
- Be careful not to scratch the glass when removing.
- Do not set or stand the glass on its edge. Small chips may develop into cracks.

INSTALLATION

Use a genuine NISSAN Urethane Adhesive Kit (if available) or equivalent and follow the instructions furnished with it.

- While the urethane adhesive is curing, open a door window. This will prevent the glass from being forced out by passenger room air pressure when a door is closed.
- The molding must be installed securely so that it is in position and leaves no gap.
- Inform the customer that the vehicle should remain stationary until the urethane adhesive has completely cured (preferably 24 hours). Curing time varies with temperature and humidity.

WARNING:

- Keep heat and open flames away from primers and adhesive as they are flammable.
- The materials contained in the kit are harmful if swallowed, and may irritate skin and eyes. Avoid contact with the skin and eyes.
- Use in an open, well ventilated location. Avoid breathing the vapors. They can be harmful if inhaled. If affected by vapor inhalation, immediately move to an area with fresh air.
- Driving the vehicle before the urethane adhesive has completely cured may affect the performance of the windshield in case of an accident.

CAUTION:

- Do not use an adhesive which is past its usable term. Shelf life of the adhesive is limited to six months after the date of manufacture. Carefully adhere to the expiration or manufacture date printed on the box.
- Keep primers and adhesive in a cool, dry place. Ideally, they should be stored in a refrigerator.
- Do not leave primers or adhesive cartridge unattended with their caps open or off.
- The vehicle should not be driven for at least 24 hours or until the urethane adhesive has completely cured. Curing time varies depending on temperature and humidities. The curing time will increase under lower temperatures and lower humidities.

INSPECTION

Repairing Water Leaks

Leaks can be repaired without removing and reinstalling glass.

If water is leaking between the urethane adhesive material and body or glass, determine the extent of leakage.

This can be done by applying water to the windshield area while pushing glass outward.

To stop the leak, apply primer (if necessary) and then urethane adhesive to the leak point.

REAR WINDOW GLASS AND MOLDING

< SERVICE INFORMATION >

REAR WINDOW GLASS AND MOLDING

Removal and Installation

INFOID:000000004409355

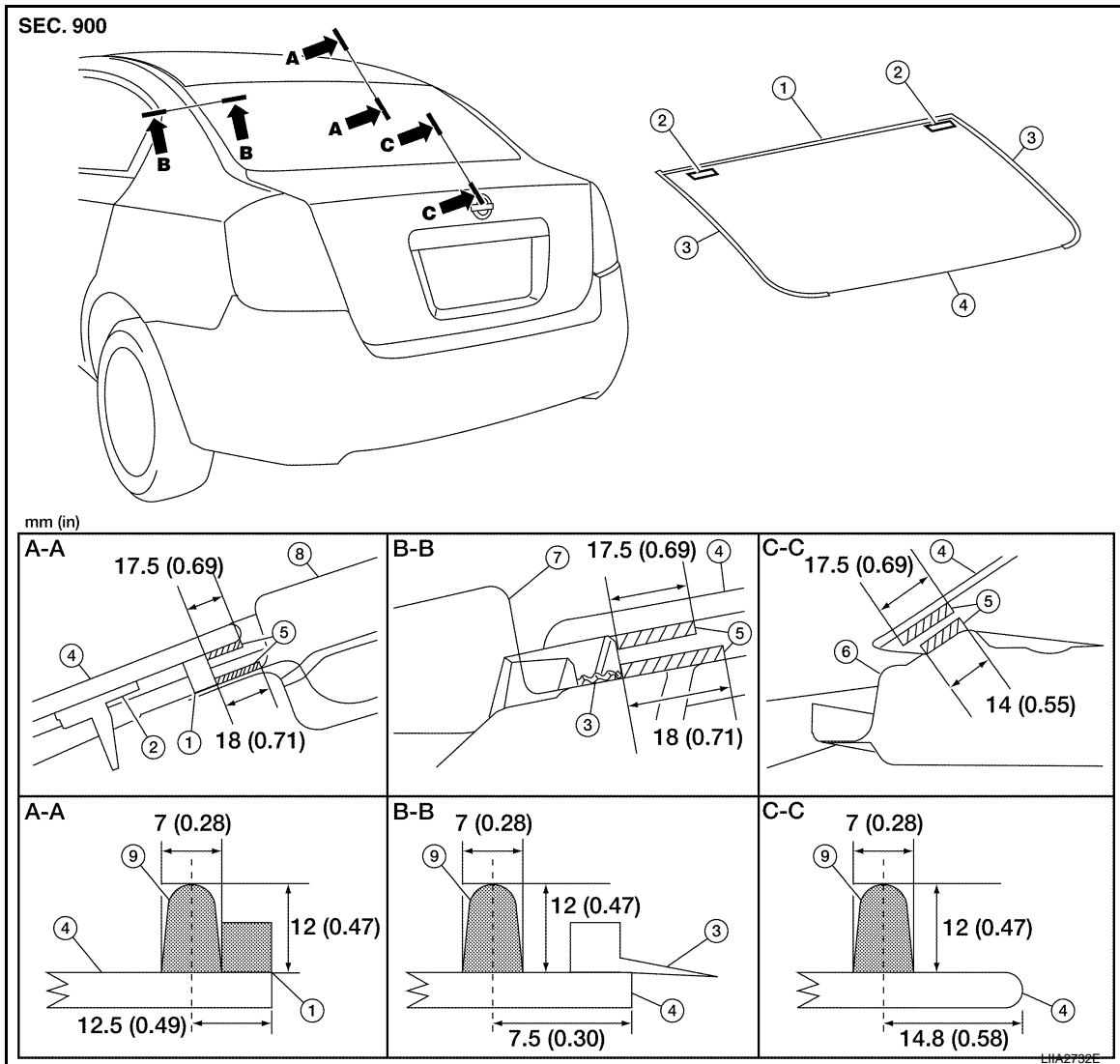

- | | | |
|--------------------------|---------------------|------------------------|
| 1. Dam Sealant | 2. Spacer | 3. Rear window molding |
| 4. Rear window glass | 5. Primer | 6. Parcel shelf panel |
| 7. Body side outer panel | 8. Roof panel outer | 9. Adhesive |

REMOVAL

1. Partially remove the headlining (rear edge). Refer to [EI-40, "Removal and Installation"](#).
2. Remove the rear seat cushion and the rear seatback. Refer to [SE-20, "Removal and Installation"](#) (folding) or [SE-24, "Removal and Installation"](#) (fixed).
3. Remove the rear seatback finisher and the rear pillar finisher. Refer to [EI-33, "Removal and Installation"](#).
4. Remove the rear parcel shelf finisher. Refer to [EI-37, "Removal and Installation"](#).
5. Disconnect the harness connector.
6. Apply protective tape around the rear window glass to protect the painted surface from damage.

REAR WINDOW GLASS AND MOLDING

< SERVICE INFORMATION >

- After removing moldings, remove glass using piano wire or power cutting tool (A) and an inflatable pump bag (B).

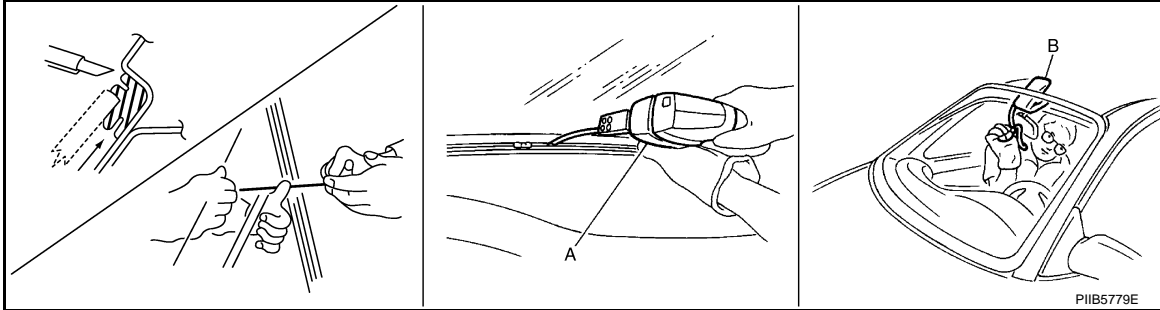

- If a rear window glass is to be reused, mark the body and the glass with mating marks.

WARNING:

When cutting the glass from the vehicle, always wear safety glasses and heavy gloves to help prevent glass splinters from entering your eyes or cutting your hands.

CAUTION:

- When a rear window glass is to be reused, do not use a cutting knife or power cutting tool.
- Be careful not to scratch the glass when removing.
- Do not set or stand the glass on its edge. Small chips may develop into cracks.

INSTALLATION

Use a genuine NISSAN Urethane Adhesive Kit (if available) or equivalent and follow the instructions furnished with it.

- While the urethane adhesive is curing, open a door window. This will prevent the glass from being forced out by passenger room air pressure when a door is closed.
- The molding must be installed securely with the double-faced adhesive tape so that it is in position and leaves no gap.
- Inform the customer that the vehicle should remain stationary until the urethane adhesive has completely cured (preferably 24 hours). Curing time varies with temperature and humidity.

WARNING:

- Keep heat and open flames away from primers and adhesive as they are flammable.
- The materials contained in the kit are harmful if swallowed, and may irritate skin and eyes. Avoid contact with the skin and eyes.
- Use in an open, well ventilated location. Avoid breathing the vapors. They can be harmful if inhaled. If affected by vapor inhalation, immediately move to an area with fresh air.
- Driving the vehicle before the urethane adhesive has completely cured may affect the performance of the rear window glass in case of an accident.

CAUTION:

- Do not use an adhesive which is past its usable term. Shelf life of the adhesive is limited to six months after the date of manufacture. Carefully adhere to the expiration or manufacture date printed on the box.
- Keep primers and adhesive in a cool, dry place. Ideally, they should be stored in a refrigerator.
- Do not leave primers or adhesive cartridge unattended with their caps open or off.
- The vehicle should not be driven for at least 24 hours or until the urethane adhesive has completely cured. Curing time varies depending on temperature and humidity. The curing time will increase under lower temperature and lower humidity.

INSPECTION

Repairing Water Leaks

Leaks can be repaired without removing and installing glass.

If water is leaking between the urethane adhesive material and body or glass, determine the extent of the leakage.

This can be done by applying water to the windshield area while pushing glass outward.

To stop the leak, apply primer (if necessary) and then urethane adhesive to the leak point.

POWER WINDOW SYSTEM

< SERVICE INFORMATION >

POWER WINDOW SYSTEM

Component Parts and Harness Connector Location

INFOID:000000004409356

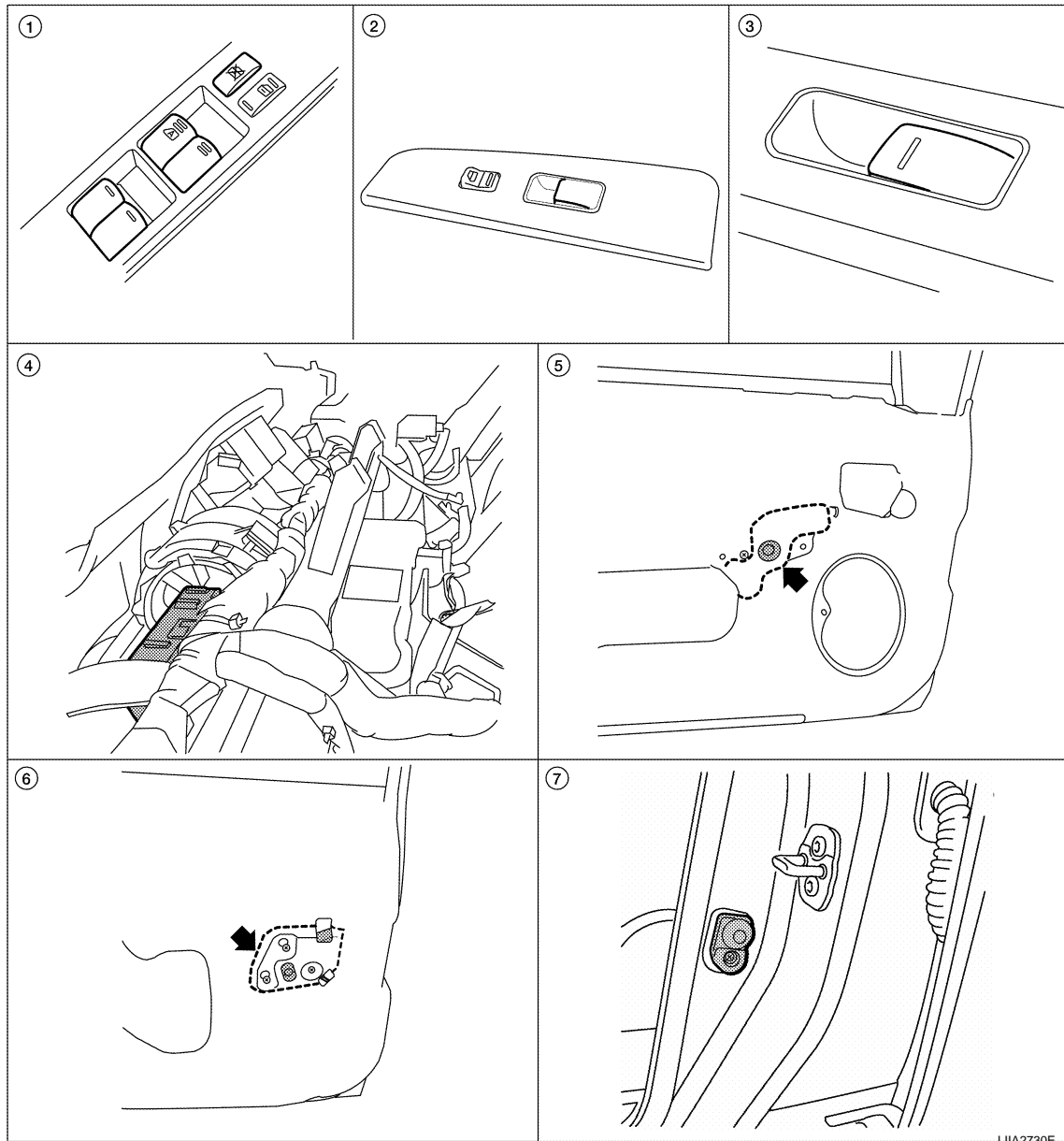

1. Main power window and door lock/unlock switch D5, D11
2. Power window and door lock/unlock switch RH D104
3. Rear power window switch LH D203, RH D303
4. BCM M18, M19, M20 (view with instrument panel removed)
5. Front power window motor LH D8, RH D105
6. Rear power window motor LH D204, RH D304
7. Front door switch LH B21, RH B28

System Description

INFOID:000000004409357

Power is supplied at all times

- from 50A fusible link (letter j, located in the fuse and fusible link box)
- to BCM terminal 70
- through BCM terminal 69
- to main power window and door lock/unlock switch terminal 19.

With ignition switch in ON or START position, power is supplied

POWER WINDOW SYSTEM

< SERVICE INFORMATION >

- through 10A fuse [No. 12, located in the fuse block (J/B)]
- to BCM terminal 38
- through BCM terminal 68
- to main power window and door lock/unlock switch terminal 10
- to power window and door lock/unlock switch RH terminal 8
- to rear power window switches LH and RH terminal 8.

With ignition switch in ACC or ON position, power is supplied

- through 10A fuse [No. 6, located in the fuse block (J/B)]
- to BCM terminal 11.

Ground is supplied

- to BCM terminal 67
- to main power window and door lock/unlock switch terminal 17
- through body grounds M57 and M61.

MANUAL OPERATION

Front Door LH

WINDOW UP

When the front LH switch in the main power window and door lock/unlock switch is pulled to the up position, power is supplied

- through main power window and door lock/unlock switch terminal 16
- to front power window motor LH terminal 3.

Ground is supplied

- through main power window and door lock/unlock switch terminal 12
- to front power window motor LH terminal 1.

Then, the motor raises the window until the switch is released (manual operation) or power is removed (automatic operation)

WINDOW DOWN

When the front LH switch in the main power window and door lock/unlock switch is pressed to the down position, power is supplied

- through main power window and door lock/unlock switch terminal 12
- to front power window motor LH terminal 1.

Ground is supplied

- through main power window and door lock/unlock switch terminal 16
- to front power window motor LH terminal 3.

Then, the motor lowers the window until the switch is released (manual operation) or power is removed (automatic operation).

Front Door RH

POWER WINDOW AND DOOR LOCK/UNLOCK SWITCH RH OPERATION

WINDOW UP

When the power window and door lock/unlock switch RH is pulled to the up position, power is supplied

- through power window and door lock/unlock switch RH terminal 7
- to front power window motor RH terminal 3.

Ground is supplied

- through power window and door lock/unlock switch RH terminal 6
- to front power window motor RH terminal 1.

Then, the motor raises the window until the switch is released.

WINDOW DOWN

When the power window and door lock/unlock switch RH is pressed in the down position, power is supplied

- through power window and door lock/unlock switch RH terminal 6
- to front power window motor RH terminal 1.

Ground is supplied

- through power window and door lock/unlock switch RH terminal 7
- to front power window motor RH terminal 3.

Then, the motor lowers the window until the switch is released.

MAIN POWER WINDOW AND DOOR LOCK/UNLOCK SWITCH OPERATION

WINDOW UP

When the main power window and door lock/unlock switch (front RH) is pulled to the up position, power is supplied

- through main power window and door lock/unlock switch terminal 8
- to power window and door lock/unlock switch RH terminal 12

POWER WINDOW SYSTEM

< SERVICE INFORMATION >

- through power window and door lock/unlock switch RH terminal 7
- to front power window motor RH terminal 3.

Ground is supplied

- through main power window and door lock/unlock switch terminal 11
- to power window and door lock/unlock switch RH terminal 11
- through power window and door lock/unlock switch LH terminal 6
- to front power window motor RH terminal 1.

Then, the motor raises the window until the switch is released.

WINDOW DOWN

When the main power window and door lock/unlock switch (front RH) is pressed in the down position, power is supplied

- through main power window and door lock/unlock switch terminal 11
- to power window and door lock/unlock switch RH terminal 11
- through power window and door lock/unlock switch RH terminal 6
- to front power window motor RH terminal 1.

Ground is supplied

- through main power window and door lock/unlock switch terminal 8
- to power window and door lock/unlock switch RH terminal 12
- through power window and door lock/unlock switch RH terminal 7
- to front power window motor RH terminal 3.

Then, the motor lowers the window until the switch is released.

Rear Door (LH or RH)

REAR POWER WINDOW SWITCH LH OR RH OPERATION

WINDOW UP

When the rear power window switch LH or RH is pulled to the up position, power is supplied

- through rear power window switch LH or RH terminal 7
- to rear power window motor LH or RH terminal 1.

Ground is supplied

- through rear power window switch LH or RH terminal 6
- to rear power window motor LH or RH terminal 2.

Then, the motor raises the window until the switch is released.

WINDOW DOWN

When the rear power window switch LH or RH is pressed in the down position, power is supplied

- through rear power window switch LH or RH terminal 6
- to rear power window motor LH or RH terminal 2.

Ground is supplied

- through rear power window switch LH or RH terminal 7
- to rear power window motor LH or RH terminal 1.

Then, the motor lowers the window until the switch is released.

MAIN POWER WINDOW AND DOOR LOCK/UNLOCK SWITCH OPERATION

WINDOW UP

When the main power window and door lock/unlock switch (rear LH) is pulled to the up position, power is supplied

- through main power window and door lock/unlock switch terminal 1
- to rear power window switch LH terminal 4
- through rear power window switch LH terminal 7
- to rear power window motor LH terminal 1.

Ground is supplied

- through main power window and door lock/unlock switch terminal 3
- to rear power window switch LH terminal 5
- through rear power window switch LH terminal 6
- to rear power window motor LH terminal 2.

Then, the motor raises the window until the switch is released.

When the main power window and door lock/unlock switch (rear RH) is pulled to the up position, power is supplied

- through main power window and door lock/unlock switch terminal 7
- to rear power window switch RH terminal 4
- through rear power window switch RH terminal 7
- to rear power window motor RH terminal 1.

Ground is supplied

- through main power window and door lock/unlock switch terminal 5

A

B

C

D

E

F

G

H

GW

J

K

L

M

N

O

P

POWER WINDOW SYSTEM

< SERVICE INFORMATION >

- through rear power window switch RH terminal 5
- to rear power window switch RH terminal 6
- to rear power window motor RH terminal 2.

Then, the motor raises the window until the switch is released.

WINDOW DOWN

When the main power window and door lock/unlock switch (rear LH) is pressed in the down position, power is supplied

- through main power window and door lock/unlock switch terminal 3
- to rear power window switch LH terminal 5
- through rear power window switch LH terminal 6
- to rear power window motor LH terminal 2.

Ground is supplied

- through main power window and door lock/unlock switch terminal 1
- to rear power window switch LH terminal 4
- through rear power window switch LH terminal 7
- to rear power window motor LH terminal 1.

Then, the motor lowers the window until the switch is released.

When the main power window and door lock/unlock switch (rear RH) is pressed in the down position, power is supplied

- through main power window and door lock/unlock switch terminal 5
- to rear power window switch RH terminal 5
- through rear power window switch RH terminal 6
- to rear power window motor RH terminal 2.

Ground is supplied

- through main power window and door lock/unlock switch terminal 7
- to rear power window switch RH terminal 4
- through rear power window switch RH terminal 7
- to rear power window motor RH terminal 1.

Then, the motor lowers the window until the switch is released.

AUTO OPERATION

The power window AUTO feature enables the driver to open or close the front door window LH without holding the window switch in the up or down position.

POWER WINDOW LOCK

The power window lock is designed to lock operation of all windows except for front door window LH.

When in the lock position, the power window lock disables power window and door lock/unlock switch RH and rear power window switch LH and RH by disconnecting switch ground signal. This prevents the power window motors from operating.

RETAINED POWER OPERATION

When the ignition switch is turned to the OFF position from ON or START position, power is supplied

- through BCM terminal 68
- to main power window and door lock/unlock switch terminal 5
- to power window and door lock/unlock switch RH terminal 8
- to rear power window switches LH and RH terminal 8.

When power and ground are supplied, the BCM continues to be energized, and the power window can be operated.

The retained power operation is canceled when the front LH or front RH door is opened.

RAP signal period can be changed by CONSULT-III.

ANTI-PINCH SYSTEM

The main power window and door lock/unlock switch monitors the power window motor operation and the power window position (fully closed or other) for the front LH power window. The switch monitors signals from the encoder and limit switch in the front power window motor LH.

When the main power window and door lock/unlock switch detects an interruption other than the fully closed signal during the automatic close operation, either with the ignition switch in the ON position, or during retained accessory power operation, the main power window and door lock/unlock switch will automatically lower the front LH power window.

CAN Communication System Description

INFOID:000000004409358

Refer to [LAN-6. "System Description"](#).

POWER WINDOW SYSTEM

< SERVICE INFORMATION >

Schematic

INFOID:000000004409363

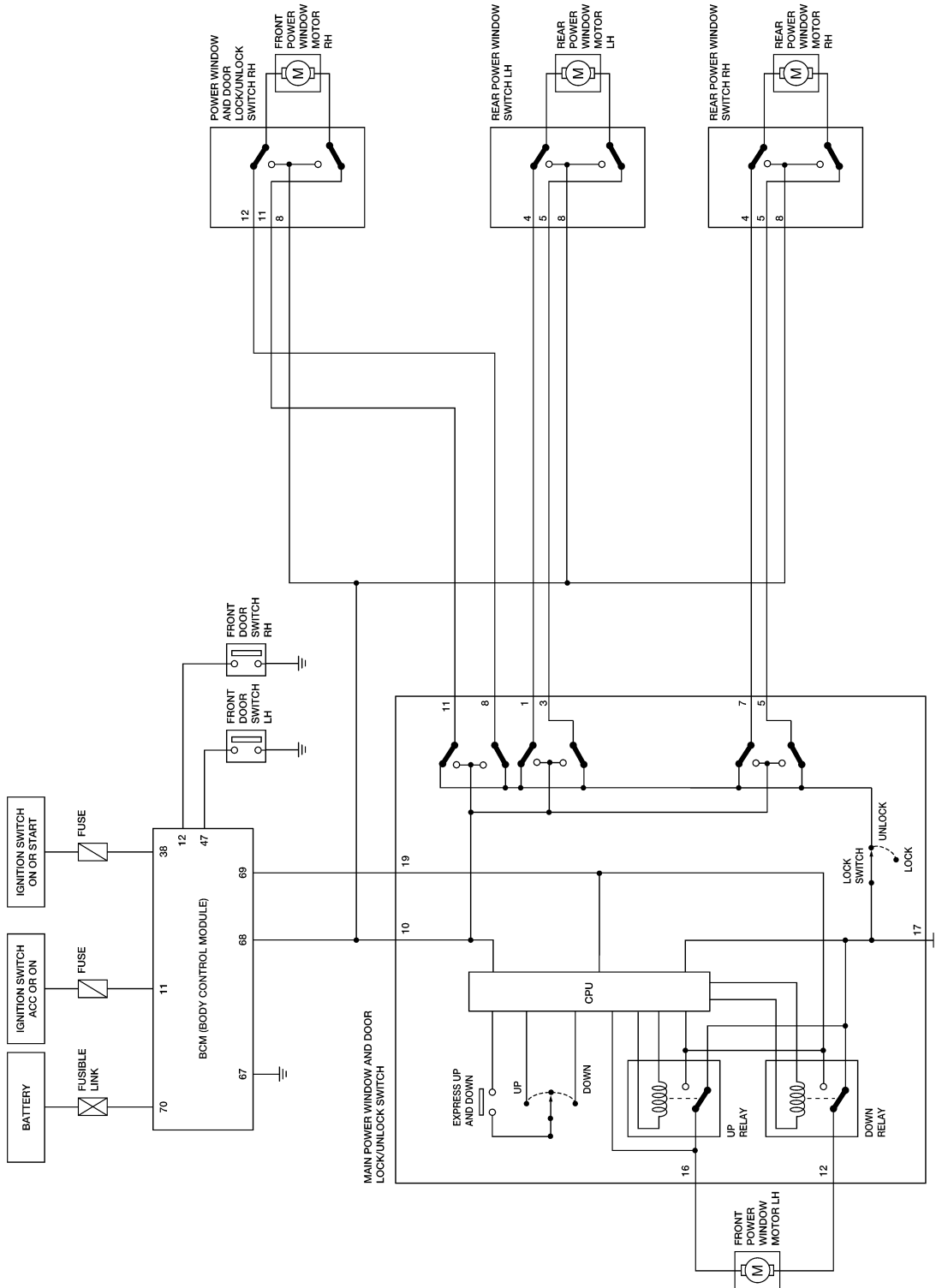

AWKWA0112GI

A
B
C
D
E
F
G
H
I
J
K
L
M
N
O
P

GW

POWER WINDOW SYSTEM

< SERVICE INFORMATION >

Wiring Diagram - WINDOW -

INFOID:000000004409364

GW-WINDOW-01

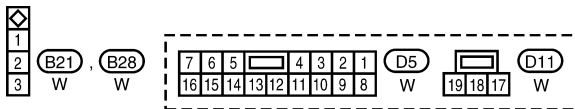
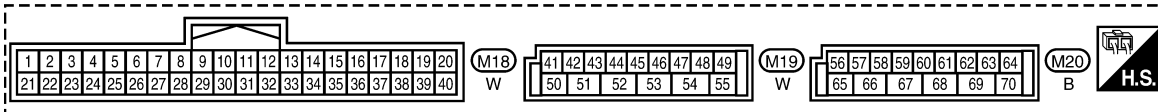
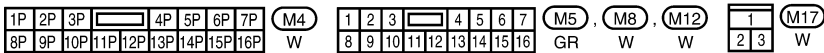
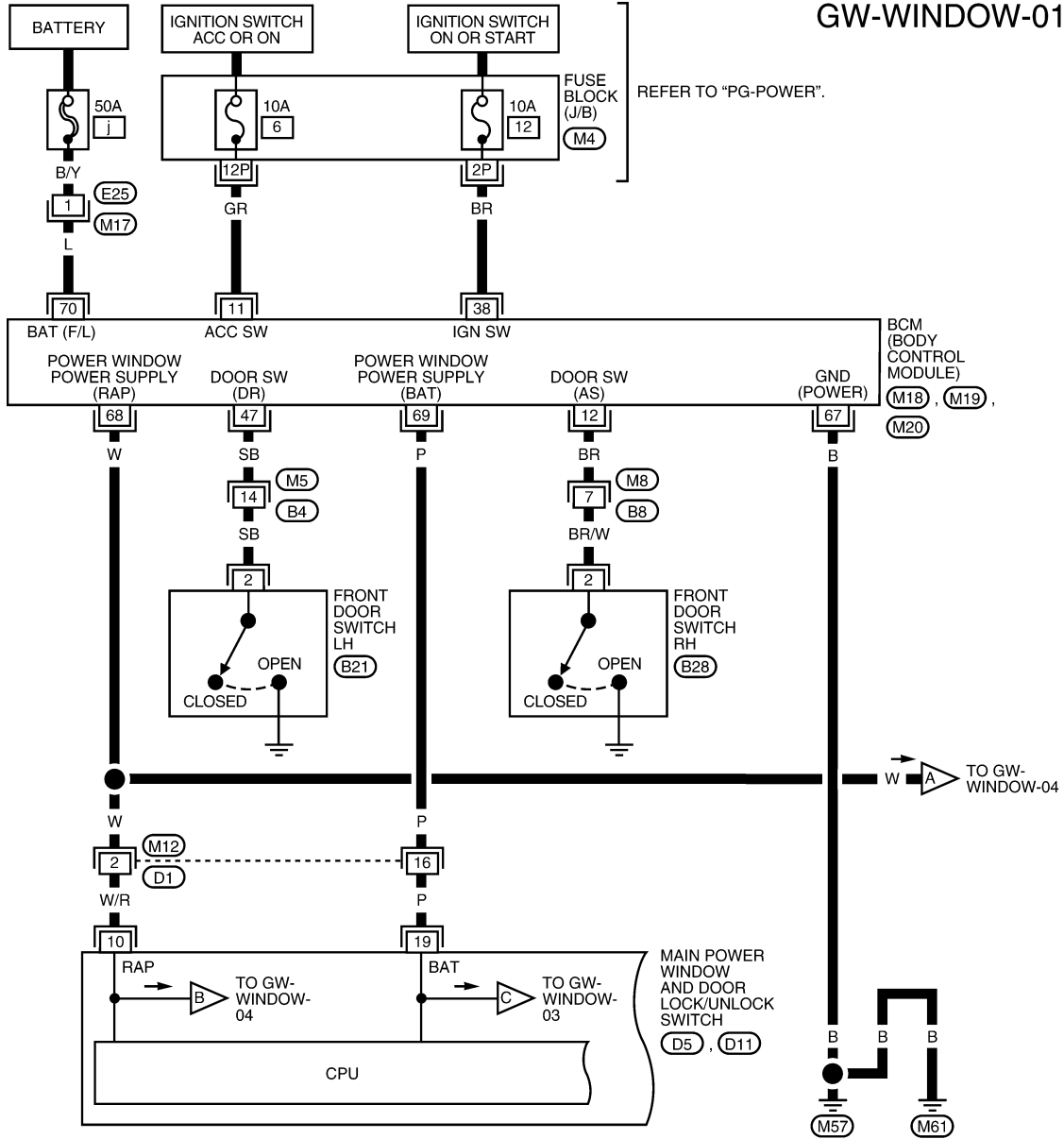

ABKWA0318GE

POWER WINDOW SYSTEM

< SERVICE INFORMATION >

GW-WINDOW-02

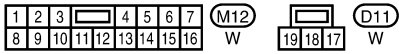
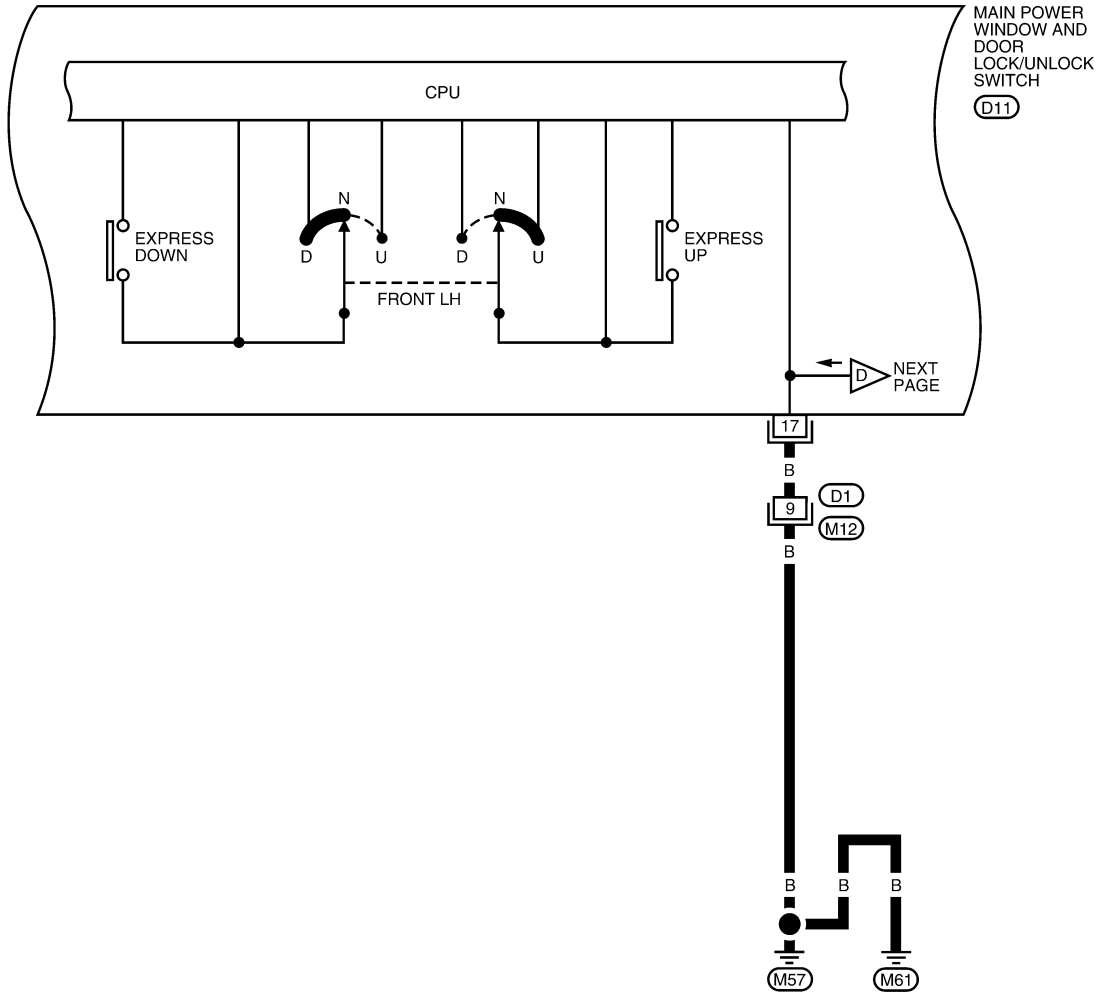

AAKWA0107GE

A
B
C
D
E
F
G
H
J
K
L
M
N
O
P

GW

POWER WINDOW SYSTEM

< SERVICE INFORMATION >

GW-WINDOW-03

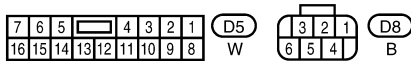
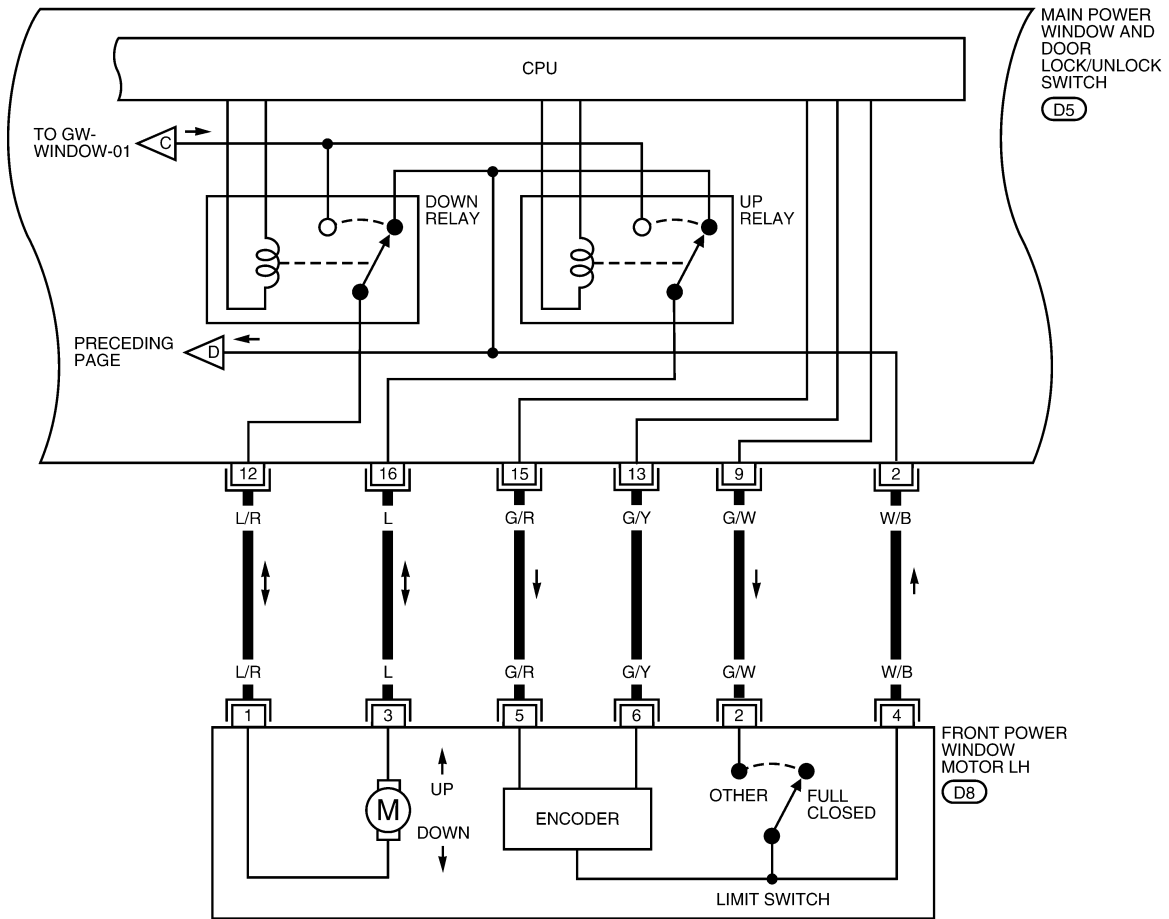

AAKWA0108GE

POWER WINDOW SYSTEM

< SERVICE INFORMATION >

GW-WINDOW-04

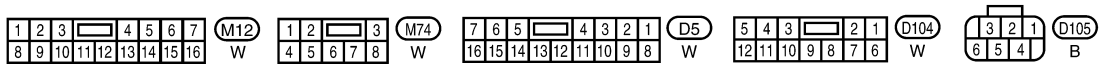
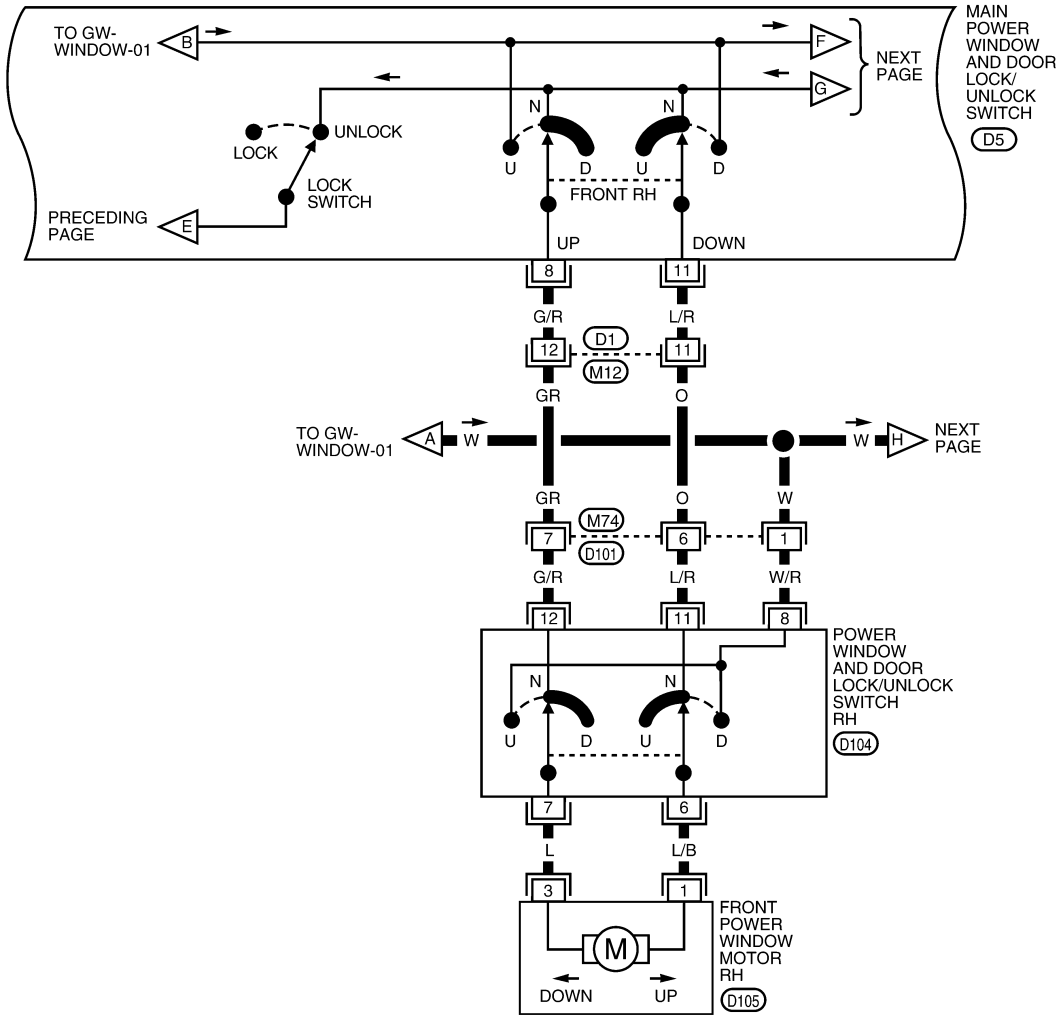

ABKWA0319GE

POWER WINDOW SYSTEM

< SERVICE INFORMATION >

GW-WINDOW-05

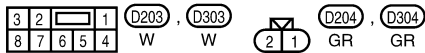
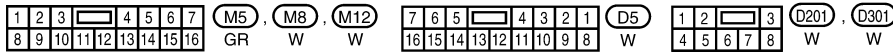
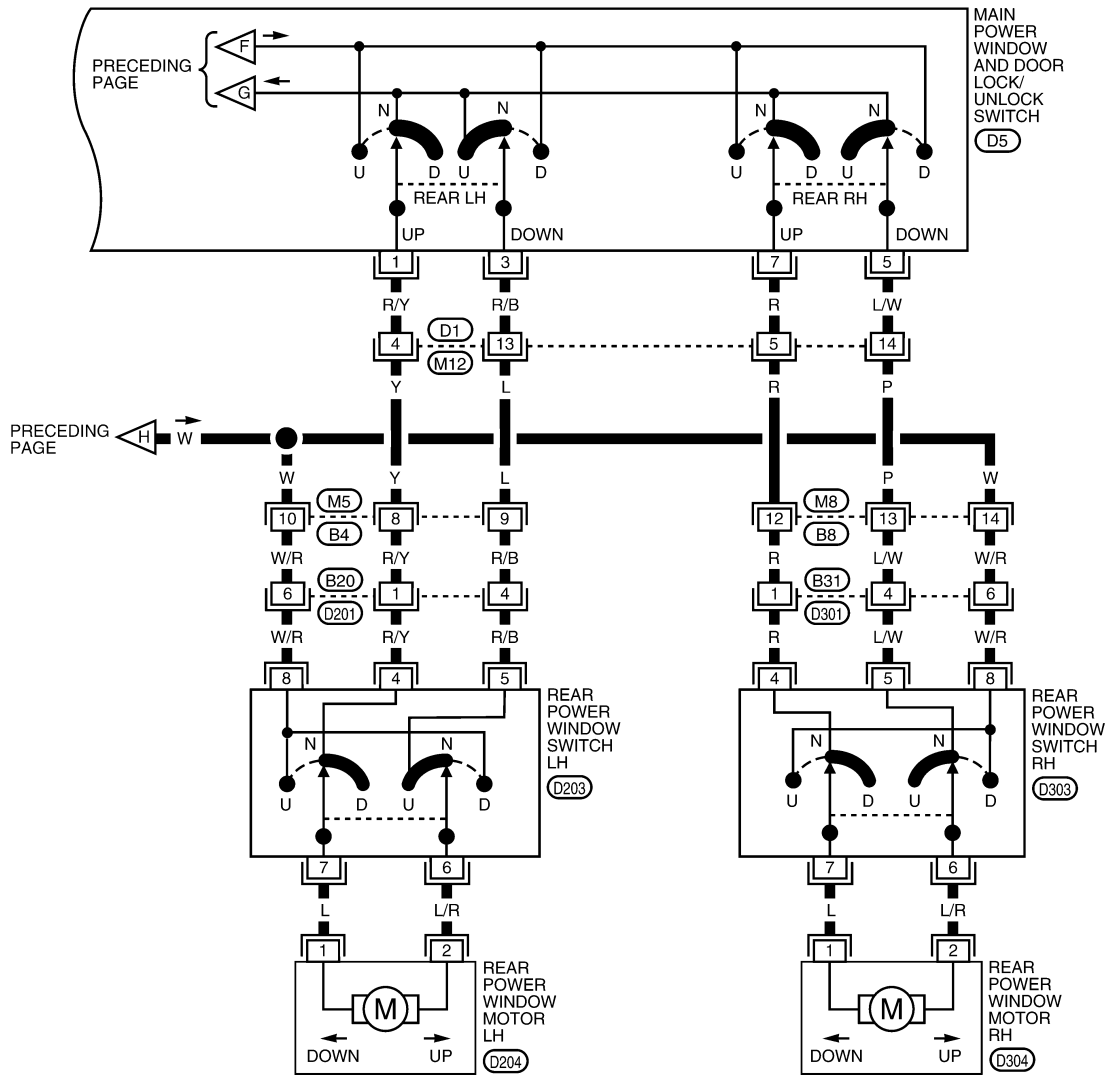

AAKWA0109GE

POWER WINDOW SYSTEM

< SERVICE INFORMATION >

Main Power Window and Door Lock/Unlock Switch Harness Connector Terminal Layout

INFOID:000000004409365

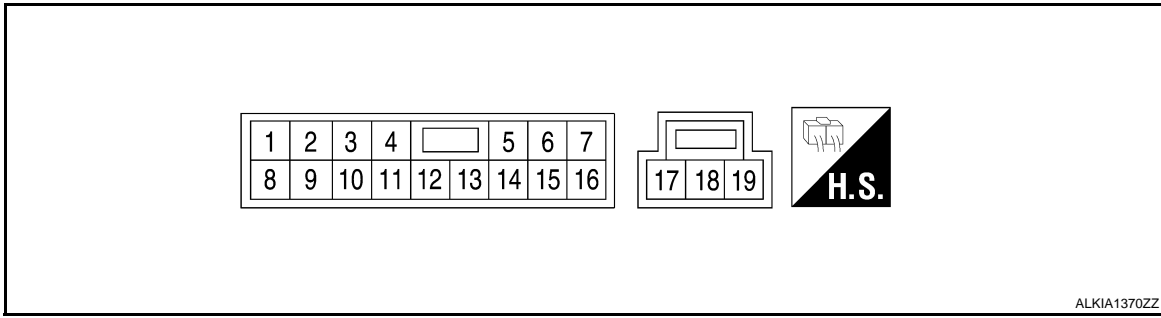

Terminal and Reference Value for Main Power Window and Door Lock/Unlock Switch

INFOID:000000004409366

With left front only power window anti-pinch system.

Terminal	Wire Color	Item	Condition	Voltage (V) (Approx.)
1	R/Y	Rear power window LH UP signal	When rear LH switch in main power window and door lock/unlock switch is operated UP	Battery voltage
2	W/B	Limit switch encoder ground	—	0
3	R/B	Rear power window LH DOWN signal	When rear LH switch in main power window and door lock/unlock switch is operated DOWN	Battery voltage
5	L/W	Rear power window RH DOWN signal	When rear RH switch in main power window and door lock/unlock switch is operated DOWN	0 → Battery voltage
7	R	Rear power window RH UP signal	When rear RH switch in main power window and door lock/unlock switch is operated UP	0 → Battery voltage
8	G/R	Front power window motor RH UP signal	When power window motor is operated UP	0 → Battery voltage
9	G/W	Limit switch signal	Front power window LH is between fully-open and just before fully-closed position (ON).	0
			Front power window LH is between just before fully-closed position and fully-closed position (OFF).	5
10	W/R	RAP signal	—	Battery voltage
11	L/R	Front power window motor RH DOWN signal	When power window motor is operated DOWN	0 → Battery voltage
12	L/R	Front power window motor LH DOWN signal	When power window motor is operated DOWN	0 → Battery voltage
13	G/Y	Encoder pulse signal	Power window motor operation.	
15	G/R	Encoder power supply	—	5 → Battery voltage

OCC3383D

POWER WINDOW SYSTEM

< SERVICE INFORMATION >

Terminal	Wire Color	Item	Condition	Voltage (V) (Approx.)
16	L	Front power window motor LH UP signal	When power window motor is operated UP	0 → Battery voltage
17	B	Ground	—	0
19	P	Battery power supply	—	Battery voltage

Terminal and Reference Value for BCM

INFOID:000000004409367

Refer to [BCS-11, "Terminal and Reference Value for BCM"](#).

Work Flow

INFOID:000000004409368

1. Check the symptom and customer's requests.
2. Understand the outline of system. Refer to [GW-15, "System Description"](#).
3. According to the trouble diagnosis chart, repair or replace the cause of the malfunction.
Refer to [GW-27, "Trouble Diagnosis Symptom Chart"](#).
4. Does power window system operate normally? Yes, GO TO 5, If No, GO TO 3.
5. Inspection End.

CONSULT-III Function (BCM)

INFOID:000000004409369

CONSULT-III can display each diagnostic item using the diagnostic test modes shown following.

BCM diagnostic test item	Diagnostic mode	Content
Inspection by part	WORK SUPPORT	Supports inspections and adjustments. Commands are transmitted to the BCM for setting the status suitable for required operation, input/output signals are received from the BCM and received data is displayed.
	DATA MONITOR	Displays BCM input/output data in real time.
	ACTIVE TEST	Operation of electrical loads can be checked by sending drive signal to them.
	SELF-DIAG RESULTS	Displays BCM self-diagnosis results.
	CAN DIAG SUPPORT MNTR	The results of transmit/receive diagnosis of CAN communication can be read.
	ECU PART NUMBER	BCM part number can be read.
	CONFIGURATION	Performs BCM configuration read/write functions.

ACTIVE TEST

Test Item	Description
RETAINED PWR	This test is able to supply RAP signal (power) from BCM (body control module) to power window system and power sunroof system (if equipped). Those systems can be operated when turning on "RETAINED PWR" on CONSULT-III screen even if the ignition switch is turned OFF. NOTE: During this test, CONSULT-III can be operated with ignition switch in OFF position. "RETAINED PWR" should be turned "ON" or "OFF" on CONSULT-III screen when ignition switch is ON. Then turn ignition switch OFF to check retained power operation. CONSULT-III might be stuck if "RETAINED PWR" is turned "ON" or "OFF" on CONSULT-III screen when ignition switch is OFF.

WORK SUPPORT

Work item	Description
RETAINED PWR SET	RAP signal's power supply period can be changed by mode setting. Selects RAP signal's power supply period between three steps. • MODE1 (45 sec.)/MODE2 (OFF)/MODE3 (2 min.).

DATA MONITOR

POWER WINDOW SYSTEM

< SERVICE INFORMATION >

Work item	Description
IGN ON SW	Indicates (ON/OFF) condition of ignition switch.
DOOR SW-DR	Indicates (ON/OFF) condition of front door switch LH.
DOOR SW-AS	Indicates (ON/OFF) condition of front door switch RH.

Trouble Diagnosis Symptom Chart

INFOID:000000004409370

Check that other systems using the signal of the following systems operate normally.

Symptom	Repair order	Refer to page
None of the power windows can be operated using any switch	1. BCM power supply and ground circuit check	BCS-14
	2. Main power window and door lock/unlock power supply and ground circuit check	GW-28
	3. Replace main power window and door lock/unlock switch	EI-30
Front power window LH alone does not operate	1. Front power window LH circuit check	GW-29
	2. Replace main power window and door lock/unlock switch	EI-30
Front power window RH alone does not operate from power window and door lock/unlock switch RH	1. Front power window RH circuit check (power window and door lock/unlock switch operation)	GW-30
Front power window RH alone does not operate from main power window and door lock/unlock switch	1. Main power window and door lock/unlock power supply and ground circuit check	GW-29
	2. Front power window RH circuit check (main power window and door lock/unlock switch operation)	GW-33
Rear power window LH alone does not operate from rear power window switch LH	1. Rear power window LH circuit check (rear power window switch LH operation)	GW-36
Rear power window LH alone does not operate from main power window and door lock/unlock switch	1. Rear power window LH circuit check (main power window and door lock/unlock switch operation)	GW-39
Rear power window RH alone does not operate from rear power window switch RH	1. Rear power window RH circuit check (rear power window switch RH operation)	GW-41
Rear power window RH alone does not operate from main power window and door lock/unlock switch	1. Rear power window RH circuit check (main power window and door lock/unlock switch operation)	GW-43
Front power window LH automatic operation does not function properly	1. Main power windows and door lock/unlock switch	GW-33
	2. Encoder and limit switch	GW-45
Power window retained power operation does not operate properly	1. Check the retained power operation mode setting.	GW-26
	2. Door switch check	BL-61
	3. Replace BCM.	BCS-17

BCM Power Supply and Ground Circuit Inspection

INFOID:000000004409371

Refer to [BCS-14](#), "BCM Power Supply and Ground Circuit Inspection".

POWER WINDOW SYSTEM

< SERVICE INFORMATION >

Main Power Window and Door Lock/Unlock Switch Power Supply and Ground Circuit Inspection

INFOID:00000004409373

1. CHECK POWER SUPPLY CIRCUIT

- Turn ignition switch ON.
- Check voltage between main power window and door lock/unlock switch connector D5 terminal 10, D11 terminal 19 and ground.

10 - Ground : Battery voltage
19 - Ground : Battery voltage

OK or NG

- OK >> GO TO 2.
 NG >> GO TO 3.

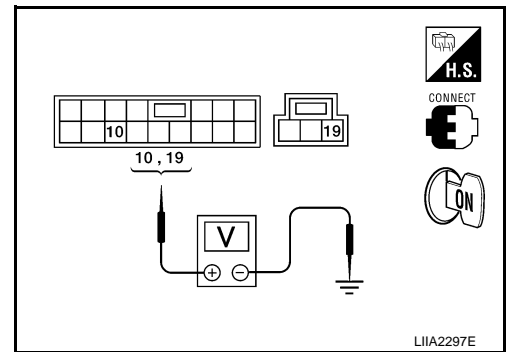

2. CHECK GROUND CIRCUIT

- Turn ignition switch OFF.
- Disconnect main power window and door lock/unlock switch.
- Check continuity between main power window and door lock/unlock switch connector and ground.

Connector	Terminals	Continuity
D5	17	Ground
		Yes

OK or NG

- OK >> Power supply and ground circuit are OK.
 NG >> Repair or replace harness.

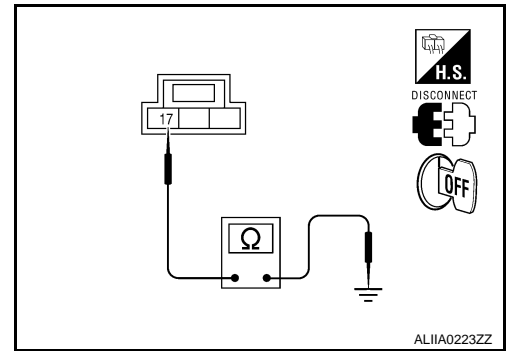

3. CHECK MAIN POWER WINDOW AND DOOR LOCK/UNLOCK SWITCH POWER SUPPLY CIRCUIT

- Turn ignition switch OFF.
- Disconnect BCM and main power window and door lock/unlock switch.
- Check continuity between BCM connector (A) and main power window and door lock/unlock switch connector (B).

Connector	Terminal	Connector	Terminal	Continuity
A		B		
	68	D5	10	Yes
M20	69	C	19	Yes
		D11		

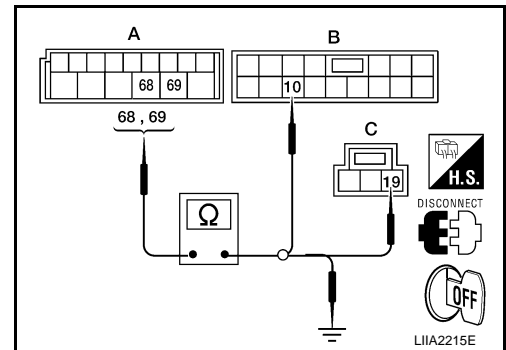

- Check continuity between BCM connector (A) and ground.

Connector	Terminal	Ground	Continuity
A			
	68		No
M20	69		No

OK or NG

- OK >> GO TO 4.
 NG >> Repair or replace harness.

4. CHECK BCM OUTPUT SIGNAL

POWER WINDOW SYSTEM

< SERVICE INFORMATION >

1. Connect BCM.
2. Turn ignition switch ON.
3. Check voltage between BCM connector M20 terminal 68, 69 and ground.

68 - Ground : Battery voltage
69 - Ground : Battery voltage

OK or NG

- OK >> Check the condition of the harness and the connector.
 NG >> Replace BCM. Refer to [BCS-17, "Removal and Installation of BCM"](#).

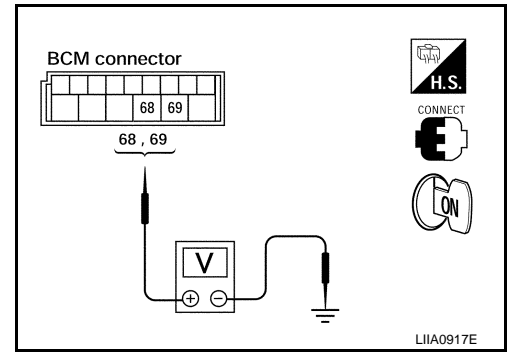

Power Window and Door Lock/Unlock Switch RH Power Supply Circuit Inspection

INFOID:000000004409374

1. CHECK POWER SUPPLY CIRCUIT

1. Turn ignition switch ON.
2. Check voltage between power window and door lock/unlock switch RH connector D104 terminal 8 and ground.

8 - Ground : Battery voltage

OK or NG

- OK >> Replace power window and door lock/unlock switch RH. Refer to [EI-30, "Removal and Installation"](#).
 NG >> GO TO 2.

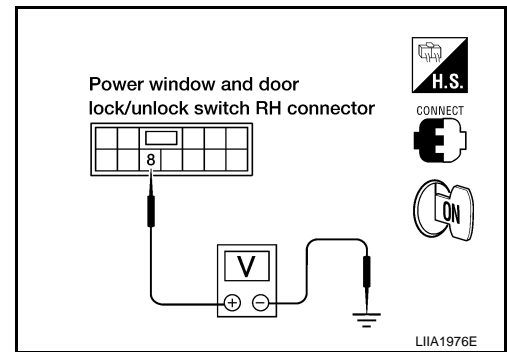

2. CHECK POWER WINDOW AND DOOR LOCK/UNLOCK SWITCH RH POWER SUPPLY CIRCUIT

1. Turn ignition switch OFF.
2. Disconnect BCM and power window and door lock/unlock switch RH.
3. Check continuity between BCM connector (A) and power window and door lock/unlock switch RH connector (B).

A		B		Continuity
Connector	Terminal	Connector	Terminal	
M20	68	D104	8	Yes

4. Check continuity between BCM connector (A) and ground.

A		Ground	Continuity
Connector	Terminal		
M20	68		No

OK or NG

- OK >> Check the condition of the harness and the connector.
 NG >> Repair or replace harness.

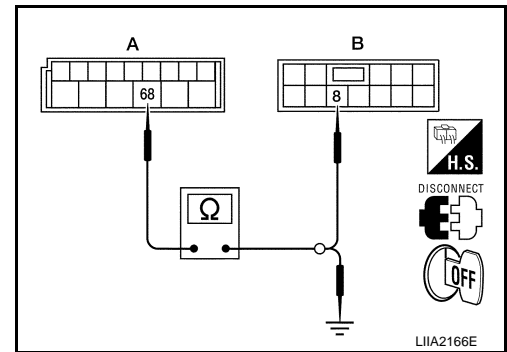

Front Power Window LH Circuit Inspection

INFOID:000000004409376

1. CHECK MAIN POWER WINDOW AND DOOR LOCK/UNLOCK SWITCH OUTPUT SIGNAL

POWER WINDOW SYSTEM

< SERVICE INFORMATION >

1. Turn ignition switch ON.
2. Check voltage between main power window and door lock/unlock switch connector and ground.

Connector	Terminals		Condition	Voltage (V) (Approx.)
	(+)	(-)		
D5	16	Ground	UP	0
			DOWN	Battery voltage
	12		UP	Battery voltage
			DOWN	0

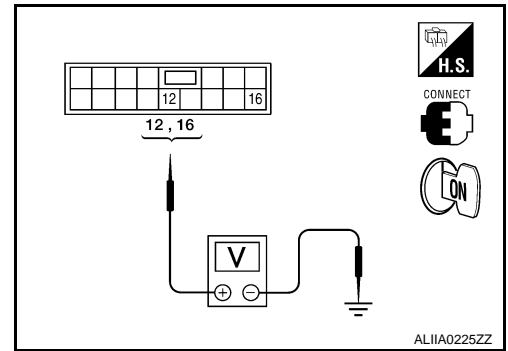

OK or NG

OK >> GO TO 2.

NG >> Replace main power window and door lock/unlock switch. Refer to [EI-30. "Removal and Installation"](#).

2. CHECK POWER WINDOW MOTOR CIRCUIT

1. Turn ignition switch OFF.
2. Disconnect main power window and door lock/unlock switch and front power window motor LH.
3. Check continuity between main power window and door lock/unlock switch connector D5 (A) terminals 6, 7 and front power window motor LH connector D8 (B) terminals 1, 3.

16 - 3 : Continuity should exist.

12 - 1 : Continuity should exist.

4. Check continuity between main power window and door lock/unlock switch connector (A) terminals 6, 7 and ground.

16 - Ground : Continuity should not exist.

12 - Ground : Continuity should not exist.

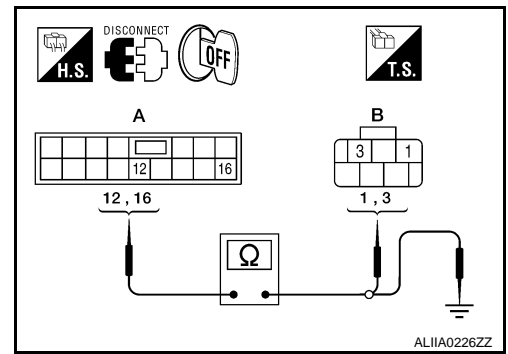

OK or NG

OK >> Replace front power window motor LH. Refer to [GW-47. "Removal and Installation"](#).

NG >> Repair or replace harness.

Front Power Window RH Circuit Inspection (Power Window and Door Lock/Unlock Switch RH Operation)

INFOID:000000004409378

1. CHECK POWER WINDOW AND DOOR LOCK/UNLOCK SWITCH RH OUTPUT SIGNAL

1. Turn ignition switch OFF.
2. Disconnect front power window motor RH.
3. Turn ignition switch ON.
4. Check voltage between front power window motor RH connector and ground.

Connector	Terminals		Condition	Voltage (V) (Approx.)
	(+)	(-)		
D105	3	Ground	UP	Battery voltage
			DOWN	0
	1		UP	0
			DOWN	Battery voltage

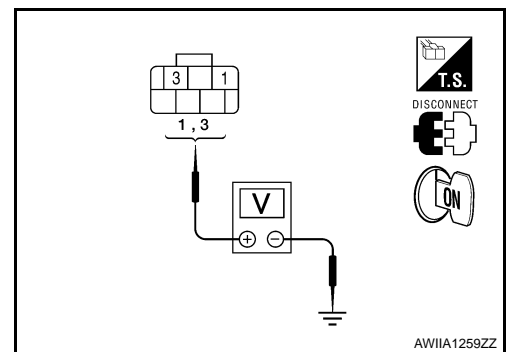

OK or NG

OK >> Replace front power window motor RH. Refer to [GW-47. "Removal and Installation"](#).

POWER WINDOW SYSTEM

< SERVICE INFORMATION >

NG >> GO TO 2.

2. CHECK POWER SUPPLY CIRCUIT

1. Turn ignition switch ON.
2. Check voltage between power window and door lock/unlock switch RH connector D104 and ground.

8 - Ground : Battery voltage

OK or NG

OK >> GO TO 4.
NG >> GO TO 3.

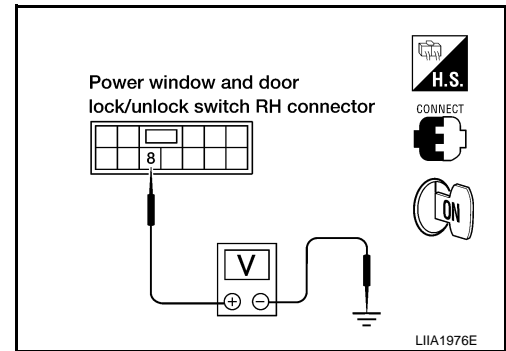

3. CHECK POWER WINDOW AND DOOR LOCK/UNLOCK SWITCH RH POWER SUPPLY CIRCUIT

1. Turn ignition switch OFF.
2. Disconnect BCM and power window and door lock/unlock switch RH.
3. Check continuity between BCM connector (A) and power window and door lock/unlock switch connector (B).

A		B		Continuity
Connector	Terminal	Connector	Terminal	
M20	68	D104	8	Yes

4. Check continuity between BCM connector (A) and ground.

A		Ground	Continuity
Connector	Terminal		
M20	68	No	

OK or NG

OK >> Check the condition of the harness and the connector.
NG >> Repair or replace harness.

4. CHECK POWER WINDOW AND DOOR LOCK/UNLOCK SWITCH RH OUTPUT SIGNAL

1. Turn ignition switch ON.
2. Check voltage between power window and door lock/unlock switch RH connector and ground.

Connector	Terminals		Condition	Voltage (V) (Approx.)
	(+)	(-)		
D104	7	Ground	UP	Battery voltage
			DOWN	0
	6		UP	0
			DOWN	Battery voltage

OK or NG

OK >> GO TO 5.
NG >> GO TO 6.

5. CHECK FRONT POWER WINDOW MOTOR RH CIRCUIT

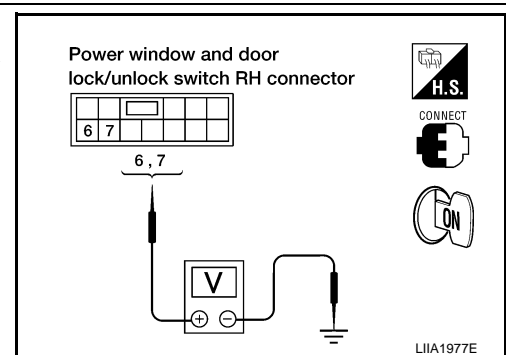
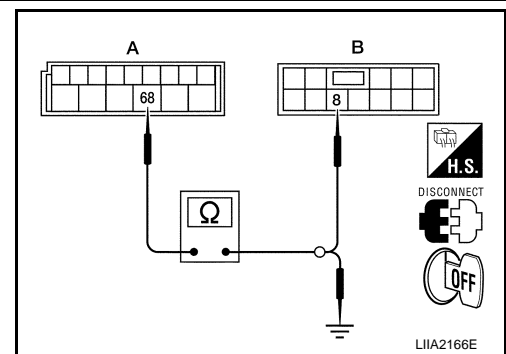

POWER WINDOW SYSTEM

< SERVICE INFORMATION >

1. Turn ignition switch OFF.
2. Disconnect front power window motor RH and power window and door lock/unlock switch RH.
3. Check continuity between power window and door lock/unlock switch RH connector D104 (A) terminals 6, 7 and front power window motor RH connector D105 (B) terminals 1, 3.

7 - 3 : Continuity should exist.

6 - 1 : Continuity should exist.

4. Check continuity between power window and door lock/unlock switch RH connector D104 (A) terminals 6, 7 and ground.

6 - Ground : Continuity should not exist.

7 - Ground : Continuity should not exist.

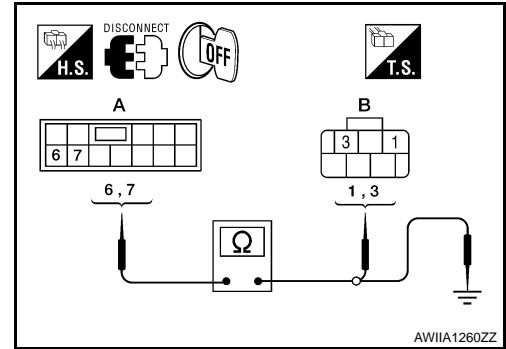

AWI1A1260ZZ

OK or NG

OK >> Replace front power window motor RH. Refer to [GW-47, "Removal and Installation"](#).

NG >> Repair or replace harness.

6. CHECK POWER WINDOW AND DOOR LOCK/UNLOCK SWITCH RH

1. Turn ignition switch OFF.
2. Check continuity between power window and door lock/unlock switch RH terminals.

	Terminals		Condition	Continuity	
	6	8			
Power window and door lock/unlock switch RH	6	8	DOWN	Yes	
		8	NEUTRAL or UP	No	
	11	11	NEUTRAL or UP	Yes	
		11	DOWN	No	
	7	8	8	UP	Yes
			8	NEUTRAL or DOWN	No
12		12	NEUTRAL or DOWN	Yes	
		12	UP	No	

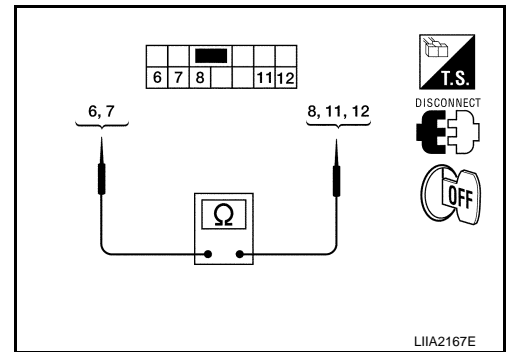

LIA2167E

OK or NG

OK >> GO TO 7.

NG >> Replace power window and door lock/unlock switch RH. refer to [EI-30, "Removal and Installation"](#).

7. CHECK POWER WINDOW AND DOOR LOCK/UNLOCK SWITCH RH GROUND SUPPLY

Check continuity between power window and door lock/unlock switch connector and ground.

Connector	Terminals	Continuity
D104	11	Yes
	12	Yes

OK or NG

OK >> Check the condition of the harness and the connector.

NG >> GO TO 8.

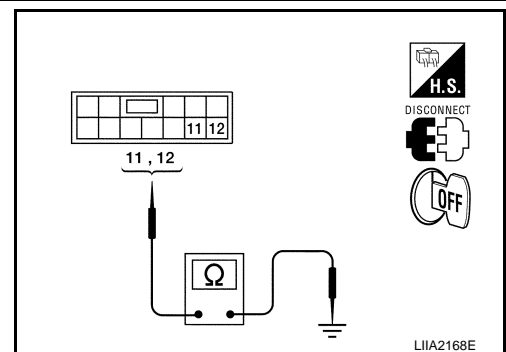

LIA2168E

8. CHECK GROUND SUPPLY CIRCUIT

POWER WINDOW SYSTEM

< SERVICE INFORMATION >

1. Disconnect main power window and door lock/unlock switch and power window and door lock/unlock switch RH.
2. Check continuity between main power window and door lock/unlock switch connector (A) and power window and door lock/unlock switch RH connector (B).

A		B		Continuity
Connector	Terminal	Connector	Terminal	
D5	11	D104	11	Yes
	8		12	Yes

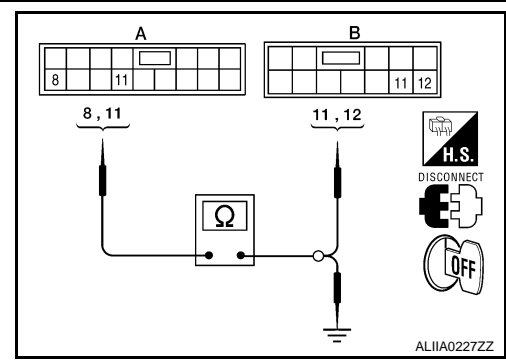

3. Check continuity between main power window and door lock/unlock switch connector (A) and ground.

A		Ground	Continuity
Connector	Terminal		
D5	11		No
	8		No

OK or NG

- OK >> GO TO 9.
 NG >> Repair or replace harness.

9. CHECK MAIN POWER WINDOW AND DOOR LOCK/UNLOCK SWITCH

Check continuity between main power window and door lock/unlock switch terminals.

Main power window and door lock/unlock switch	Terminals		Condition	Continuity
	17			
	11		Lock switch UNLOCK	Yes
			Lock switch LOCK	No
	8		Lock switch UNLOCK	Yes
			Lock switch LOCK	No

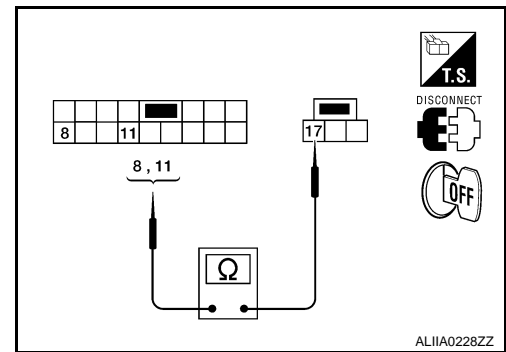

OK or NG

- OK >> Repair or replace harness.
 NG >> Replace main power window and door lock/unlock switch. Refer to [EI-30, "Removal and Installation"](#).

Front Power Window RH Circuit Inspection (Main Power Window and Door Lock/Unlock Switch Operation)

INFOID:000000004409380

1. CHECK MAIN POWER WINDOW AND DOOR LOCK/UNLOCK SWITCH OUTPUT SIGNAL

1. Disconnect front power window motor RH.
2. Turn ignition switch ON.
3. Check voltage between front power window motor RH connector and ground.

Connector	Terminals		Condition	Voltage (V) (Approx.)
	(+)	(-)		
D105	1	Ground	UP	0
			DOWN	Battery voltage
	3		UP	Battery voltage
			DOWN	0

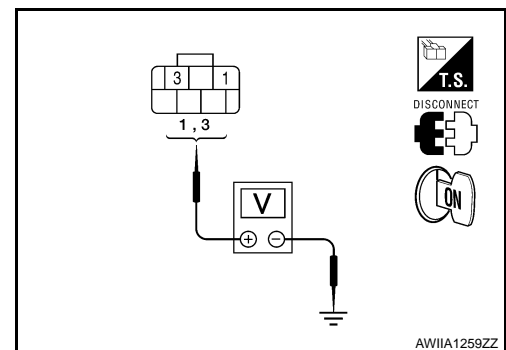

OK or NG

- OK >> Replace front power window motor RH. Refer to [GW-47, "Removal and Installation"](#).

POWER WINDOW SYSTEM

< SERVICE INFORMATION >

NG >> GO TO 2.

2. CHECK FRONT POWER WINDOW MOTOR RH CIRCUIT

1. Disconnect front power window motor RH and power window and door lock/unlock switch RH.
2. Check continuity between power window and door lock/unlock switch RH connector D104 (A) terminals 6, 7 and front power window motor RH connector D105 (B) terminals 1, 3.

7 - 3 : Continuity should exist.

6 - 1 : Continuity should exist.

3. Check continuity between power window and door lock/unlock switch RH connector D104 (A) terminals 6, 7 and ground.

6 - Ground : Continuity should not exist.

7 - Ground : Continuity should not exist.

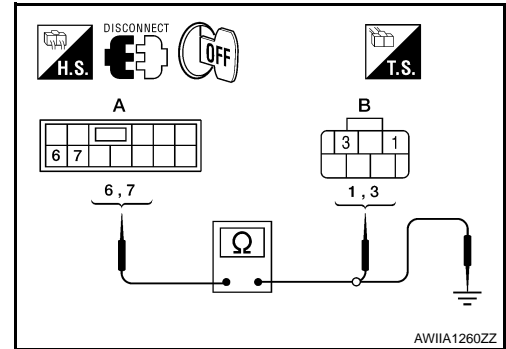

OK or NG

OK >> GO TO 3.

NG >> Repair or replace harness.

3. CHECK POWER WINDOW AND DOOR LOCK/UNLOCK SWITCH RH

Check continuity between power window and door lock/unlock switch RH terminals.

Power window and door lock/unlock switch	Terminals		Continuity
	6	11	
	7	12	Yes

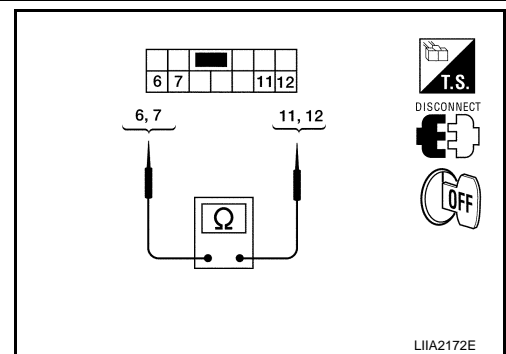

OK or NG

OK >> GO TO 4.

NG >> Replace power window and door lock/unlock switch RH.
Refer to [EI-30, "Removal and Installation"](#).

4. CHECK GROUND SUPPLY CIRCUIT

1. Disconnect main power window and door lock/unlock switch.
2. Check continuity between main power window and door lock/unlock switch and power window connector (A) and door lock/unlock switch RH connector (B).

A		B		Continuity
Connector	Terminal	Connector	Terminal	
D5	11	D104	11	Yes
	8		12	Yes

3. Check continuity between main power window and door lock/unlock switch connector (A) and ground.

A		Ground	Continuity
Connector	Terminal		
D5	11		No
	8		No

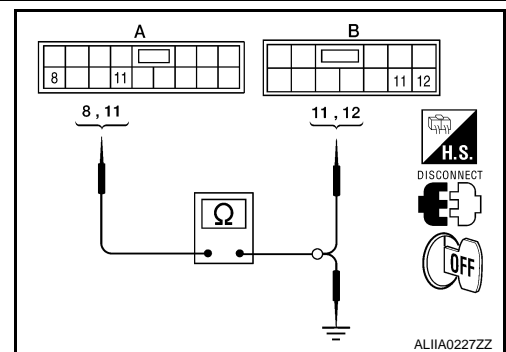

OK or NG

OK >> GO TO 5.

NG >> Repair or replace harness.

POWER WINDOW SYSTEM

< SERVICE INFORMATION >

5. CHECK MAIN POWER WINDOW AND DOOR LOCK/UNLOCK SWITCH SIGNAL

1. Connect main power window and door lock/unlock switch.
2. Turn ignition switch ON.
3. Check voltage between main power window and door lock/unlock switch connector and ground.

Connector	Terminals		Condition	Voltage (V) (Approx.)
	(+)	(-)		
D5	8	Ground	UP	Battery voltage
			DOWN	0
	11		UP	0
			DOWN	Battery voltage

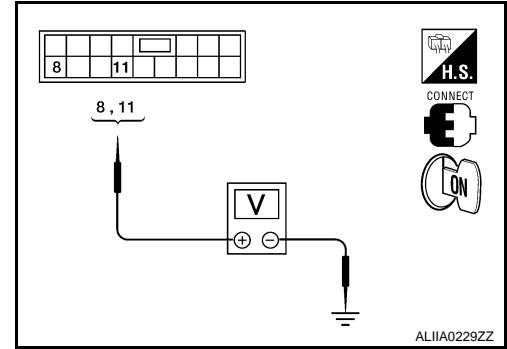

OK or NG

OK >> Repair or replace harness.

NG >> Replace main power window and door lock/unlock switch. Refer to [EI-30, "Removal and Installation"](#).

Door Switch Check

INFOID:000000004409381

1. CHECK FRONT DOOR SWITCH INPUT SIGNAL

With CONSULT-III

Check front door switches ("DOOR SW-DR" and "DOOR SW-AS") in "DATA MONITOR" mode with CONSULT-III.

Monitor item	Condition
DOOR SW-DR	OPEN: ON
	CLOSE: OFF
DOOR SW-AS	OPEN: ON
	CLOSE: OFF

Without CONSULT-III

Check voltage between BCM connector and ground.

Item	Connector	Terminals		Condition	Voltage (V) (Approx.)
		(+)	(-)		
Front RH	M18	12	Ground	OPEN	0
				CLOSE	Battery voltage
Front LH	M19	47		OPEN	0
				CLOSE	Battery voltage

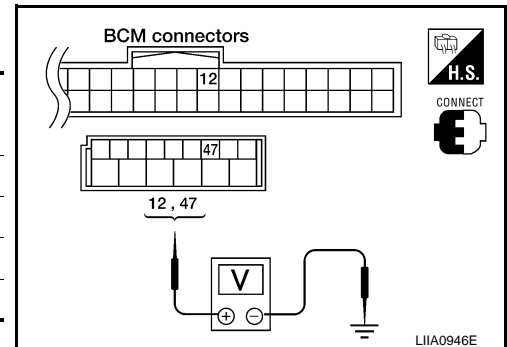

OK or NG

OK >> Front door switch is OK.

NG >> GO TO 2.

2. CHECK FRONT DOOR SWITCH CIRCUIT

POWER WINDOW SYSTEM

< SERVICE INFORMATION >

1. Turn ignition switch OFF.
2. Disconnect front door switch LH or RH and BCM.
3. Check continuity between front door switch connector B21 (LH) or B28 (RH) terminal 2 and BCM connector M19 terminal 47 (LH) or connector M18 terminal 12 (RH).

Front LH
2 - 47 : Continuity should exist.
Front RH
2 - 12 : Continuity should exist.

4. Check continuity between front door switch connector B21 (LH) or B28 (RH) terminal 2 and ground.

2 - Ground : Continuity should not exist.

OK or NG

- OK >> GO TO 3.
 NG >> Repair or replace harness.

3.CHECK DOOR SWITCH

1. Disconnect front door switch LH or RH.
2. Check continuity between each front door switch terminal 2 and body ground part of front door switch.

Terminal	Door switch	Continuity
2	Pushed	No
	Released	Yes

OK or NG

- OK >> Replace BCM. Refer to [BCS-17. "Removal and Installation of BCM"](#).
 NG >> Replace malfunctioning front door switch.

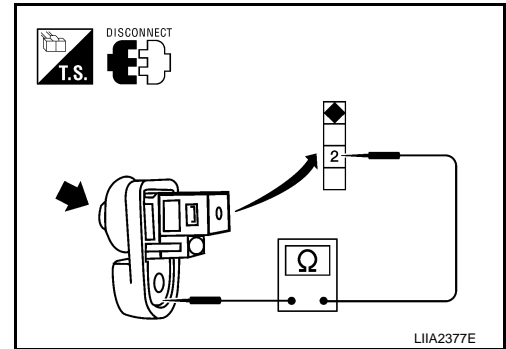
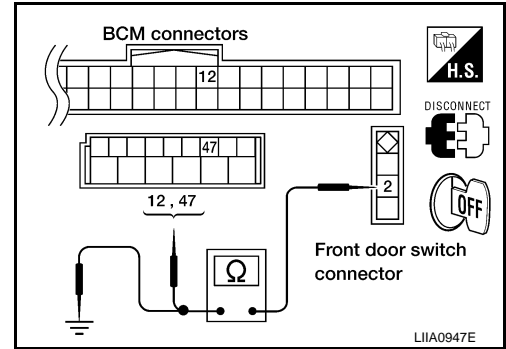

Rear Power Window LH Circuit Inspection (Rear Power Window Switch LH Operation)

INFOID:000000004409383

1.CHECK REAR POWER WINDOW SWITCH LH OUTPUT SIGNAL

1. Turn ignition switch OFF.
2. Disconnect rear power window motor LH.
3. Turn ignition switch ON.
4. Check voltage between rear power window motor LH connector and ground.

Connector	Terminals		Condition	Voltage (V) (Approx.)
	(+)	(-)		
D204	2	Ground	UP	0
			DOWN	Battery voltage
	1		UP	Battery voltage
			DOWN	0

OK or NG

- OK >> Replace rear power window motor LH. Refer to [GW-51. "Removal and Installation"](#).
 NG >> GO TO 2.

2.CHECK REAR POWER WINDOW MOTOR LH CIRCUIT

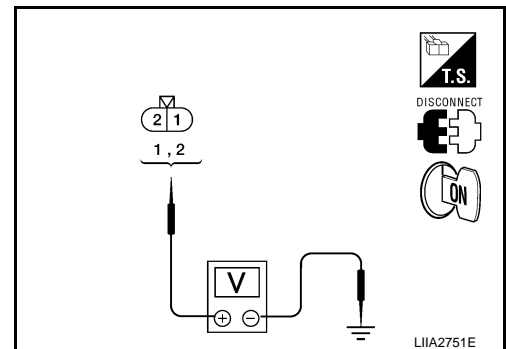

POWER WINDOW SYSTEM

< SERVICE INFORMATION >

1. Turn ignition switch OFF.
2. Disconnect rear power window switch LH.
3. Check continuity between rear power window switch LH connector (A) and rear power window motor LH connector (B).

Connector	Terminal	Connector	Terminal	Continuity
A		B		
D203	6	D204	2	Yes
	7		1	Yes

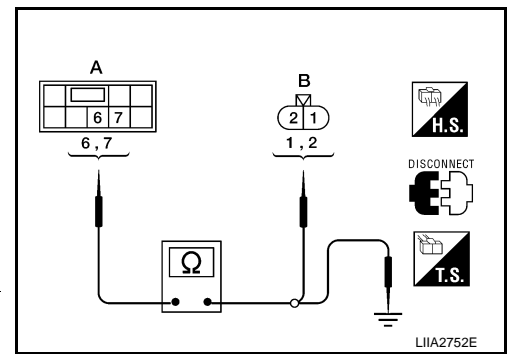

4. Check continuity between rear power window switch LH connector (A) and ground.

Connector	Terminal	Ground	Continuity
A			
D203	6	Ground	No
	7		No

OK or NG

- OK >> GO TO 3.
 NG >> Repair or replace harness.

3. CHECK POWER SUPPLY

1. Connect rear power window switch LH.
2. Turn ignition switch ON.
3. Check voltage between rear power window switch LH connector D203 terminal 8 and ground.

8 - Ground : Battery voltage

OK or NG

- OK >> GO TO 4.
 NG >> GO TO 5.

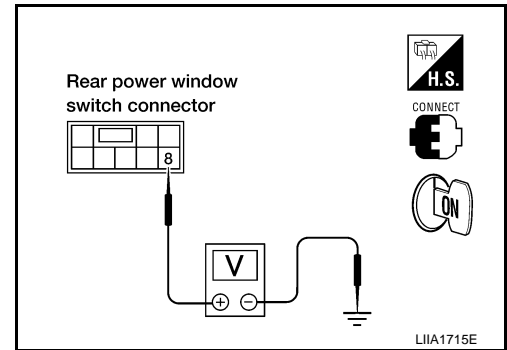

4. CHECK REAR POWER WINDOW SWITCH LH

1. Turn ignition switch OFF.
2. Disconnect rear power window switch LH.
3. Check continuity between rear power window switch LH terminals.

	Terminals		Condition	Continuity
	Rear power window switch LH	6	5	DOWN
NEUTRAL or UP				Yes
8		8	NEUTRAL or UP	No
			DOWN	Yes
7		4	UP	No
			NEUTRAL or DOWN	Yes
	8	NEUTRAL or DOWN	No	
		UP	Yes	

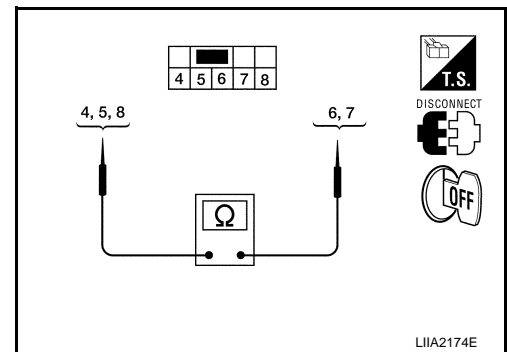

OK or NG

- OK >> GO TO 6.
 NG >> Replace rear power window switch LH. Refer to [EI-30. "Removal and Installation"](#).

5. CHECK REAR POWER WINDOW SWITCH LH POWER SUPPLY CIRCUIT

POWER WINDOW SYSTEM

< SERVICE INFORMATION >

1. Turn ignition switch OFF.
2. Disconnect BCM.
3. Check continuity between BCM connector (A) and rear power window switch LH connector (B).

A		B		Continuity
Connector	Terminal	Connector	Terminal	
M20	68	D203	8	Yes

4. Check continuity between BCM connector (A) and ground.

A		Ground	Continuity
Connector	Terminal		
M20	68	No	

OK or NG

- OK >> GO TO 6.
 NG >> Repair or replace harness.

6. CHECK REAR POWER WINDOW SWITCH LH GROUND SUPPLY

Check continuity between rear power window switch LH connector and ground.

Connector	Terminals	Continuity
D203	4	Yes
	5	Yes

OK or NG

- OK >> Check the condition of the harness and the connector.
 NG >> GO TO 7.

7. CHECK GROUND SUPPLY CIRCUIT

1. Disconnect main power window and door lock/unlock switch.
2. Check continuity between main power window and door lock/unlock switch connector (A) and rear power window switch LH connector (B).

A		B		Continuity
Connector	Terminal	Connector	Terminal	
D5	1	D203	4	Yes
	3		5	Yes

3. Check continuity between main power window and door lock/unlock switch connector (B) and ground.

A		Ground	Continuity
Connector	Terminal		
D5	1	No	
	3	No	

OK or NG

- OK >> GO TO 8.
 NG >> Repair or replace harness.

8. CHECK MAIN POWER WINDOW AND DOOR LOCK/UNLOCK SWITCH

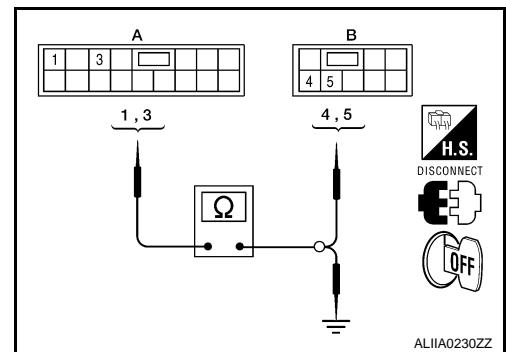
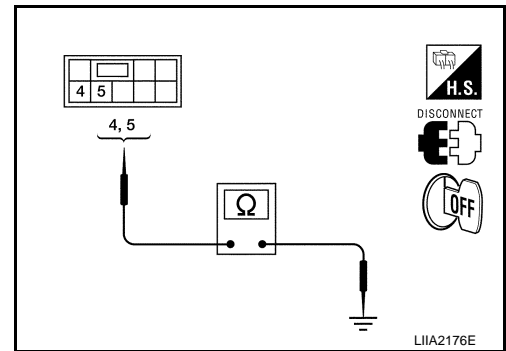
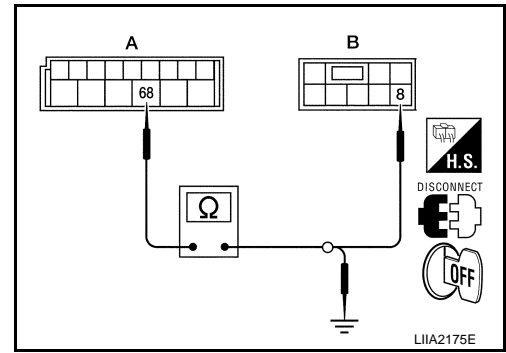

POWER WINDOW SYSTEM

< SERVICE INFORMATION >

Check continuity between main power window and door lock/unlock switch terminals.

	Terminals		Condition	Continuity
	17	1		
Main power window and door lock/unlock switch	17	1	Lock switch UNLOCK	Yes
			Lock switch LOCK	No
	3	3	Lock switch UNLOCK	Yes
			Lock switch LOCK	No

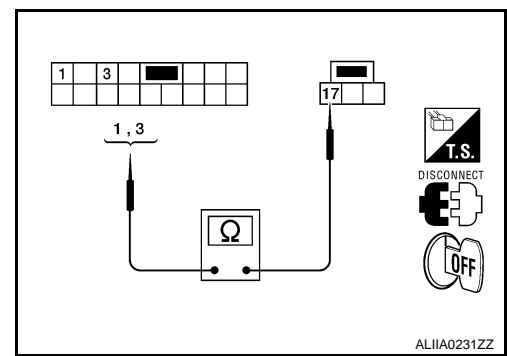

OK or NG

OK >> Repair or replace harness.

NG >> Replace main power window and door lock/unlock switch. Refer to [EI-30, "Removal and Installation"](#).

Rear Power Window LH Circuit Inspection (Main Power Window and Door Lock/Unlock Switch Operation)

INFOID:000000004409385

1. CHECK MAIN POWER WINDOW AND DOOR LOCK/UNLOCK SWITCH OUTPUT SIGNAL

1. Turn ignition switch OFF.
2. Disconnect rear power window motor LH.
3. Turn ignition switch ON.
4. Check voltage between rear power window motor LH connector and ground.

Connector	Terminals		Condition	Voltage (V) (Approx.)
	(+)	(-)		
D204	2	Ground	UP	0
			DOWN	Battery voltage
	1		UP	Battery voltage
			DOWN	0

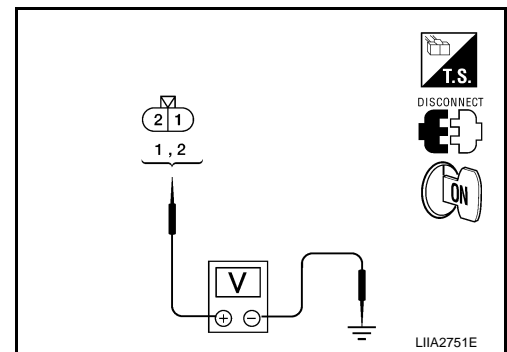

OK or NG

OK >> Replace rear power window motor LH. Refer to [GW-51, "Removal and Installation"](#).

NG >> GO TO 2.

2. CHECK REAR POWER WINDOW MOTOR LH CIRCUIT

1. Turn ignition switch OFF.
2. Disconnect rear power window switch LH.
3. Check continuity between rear power window switch LH connector (A) and rear power window motor LH connector (B).

Connector	Terminal	Connector	Terminal	Continuity
A		B		
D203	6	D204	2	Yes
	7		1	Yes

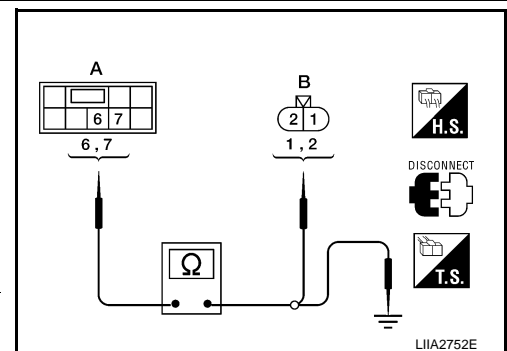

4. Check continuity between rear power window switch LH connector (A) and ground.

Connector	Terminal	Ground	Continuity
A			
D203	6		No
	7		No

OK or NG

POWER WINDOW SYSTEM

< SERVICE INFORMATION >

- OK >> GO TO 3.
- NG >> Repair or replace harness.

3. CHECK REAR POWER WINDOW SWITCH LH

Check continuity between rear power window switch LH terminals.

Rear power window switch LH	Terminals		Continuity
	4	7	Yes
	5	6	Yes

OK or NG

- OK >> GO TO 4.
- NG >> Replace rear power window switch LH. Refer to [EI-30](#), "[Removal and Installation](#)".

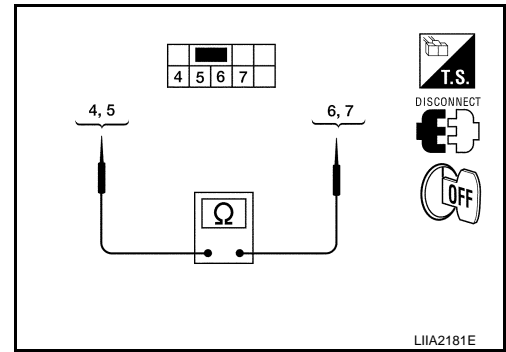

4. CHECK GROUND SUPPLY CIRCUIT

1. Disconnect main power window and door lock/unlock switch.
2. Check continuity between main power window and door lock/unlock switch connector (A) and rear power window switch LH connector (B).

A		B		Continuity
Connector	Terminal	Connector	Terminal	
D5	1	D203	4	Yes
	3		5	Yes

3. Check continuity between main power window and door lock/unlock switch connector (A) and ground.

A		Ground	Continuity
Connector	Terminal		
D5	1		No
	3		No

OK or NG

- OK >> GO TO 5.
- NG >> Repair or replace harness.

5. CHECK MAIN POWER WINDOW AND DOOR LOCK/UNLOCK SWITCH

Check continuity between main power window and door lock/unlock switch terminals.

Main power window and door lock/unlock switch	Terminals		Condition	Continuity
	17	1		Lock switch UNLOCK
			Lock switch LOCK	No
3			Lock switch UNLOCK	Yes
			Lock switch LOCK	No

OK or NG

- OK >> Repair or replace harness.
- NG >> Replace main power window and door lock/unlock switch. Refer to [EI-30](#), "[Removal and Installation](#)".

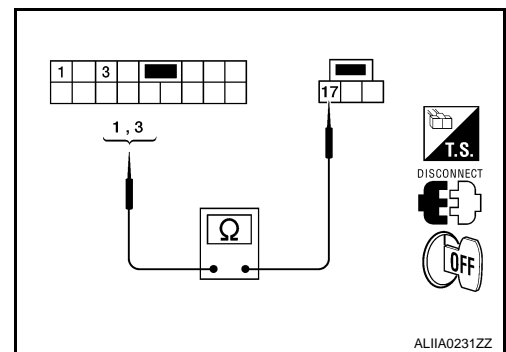

POWER WINDOW SYSTEM

< SERVICE INFORMATION >

Rear Power Window RH Circuit Inspection (Rear Power Window Switch RH Operation)

INFOID:000000004409387

1. CHECK REAR POWER WINDOW SWITCH RH OUTPUT SIGNAL

1. Turn ignition switch OFF.
2. Disconnect rear power window motor RH.
3. Turn ignition switch ON.
4. Check voltage between rear power window motor RH connector and ground.

Connector	Terminals		Condition	Voltage (V) (Approx.)
	(+)	(-)		
D304	2	Ground	UP	0
			DOWN	Battery voltage
	1		UP	Battery voltage
			DOWN	0

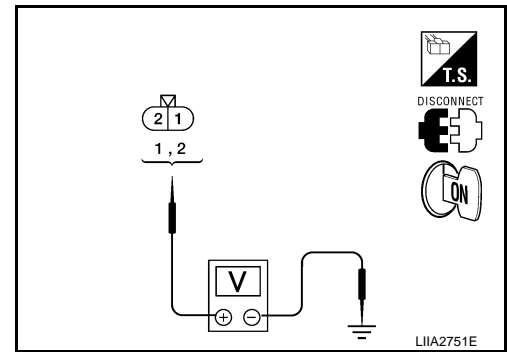

OK or NG

- OK >> Replace rear power window motor RH. Refer to [GW-51, "Removal and Installation"](#).
 NG >> GO TO 2.

2. CHECK REAR POWER WINDOW MOTOR RH CIRCUIT

1. Turn ignition switch OFF.
2. Disconnect rear power window switch RH.
3. Check continuity between rear power window switch RH connector (A) and rear power window motor RH connector (B).

Connector	Terminal	Connector	Terminal	Continuity
A		B		
D303	6	D304	2	Yes
	7		1	Yes

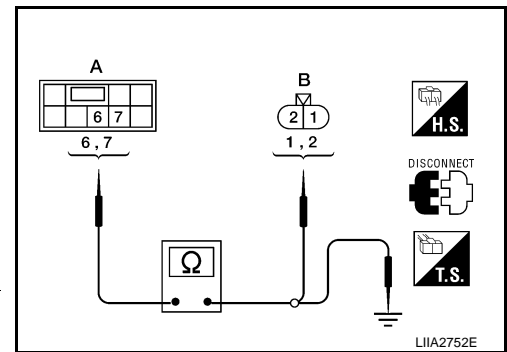

4. Check continuity between rear power window switch RH connector (A) and ground.

Connector	Terminal	Ground	Continuity
A			
D303	6	Ground	No
	7		No

OK or NG

- OK >> GO TO 3.
 NG >> Repair or replace harness.

3. CHECK POWER SUPPLY

1. Connect rear power window switch RH.
2. Turn ignition switch ON.
3. Check voltage between rear power window switch RH connector D303 terminal 8 and ground.

8 - Ground : Battery voltage

OK or NG

- OK >> GO TO 4.
 NG >> GO TO 5.

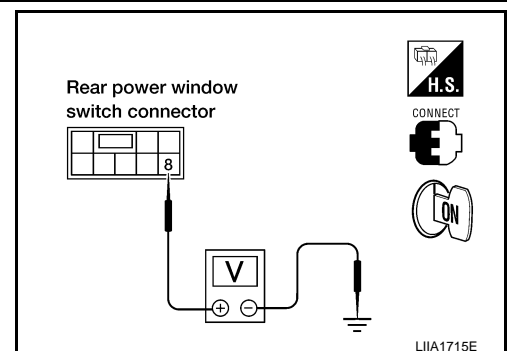

POWER WINDOW SYSTEM

< SERVICE INFORMATION >

4. CHECK REAR POWER WINDOW SWITCH RH

1. Turn ignition switch OFF.
2. Disconnect rear power window switch RH.
3. Check continuity between rear power window switch RH terminals.

	Terminals		Condition	Continuity
	Rear power window switch RH	6	5	DOWN
NEUTRAL or UP				Yes
8			NEUTRAL or UP	No
			DOWN	Yes
7		4	UP	No
			NEUTRAL or DOWN	Yes
	8	NEUTRAL or DOWN	No	
		UP	Yes	

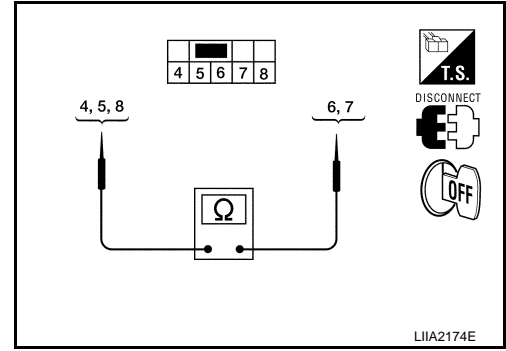

OK or NG

OK >> GO TO 6.

NG >> Replace rear power window switch RH. Refer to [EI-30, "Removal and Installation"](#).

5. CHECK REAR POWER WINDOW SWITCH RH POWER SUPPLY CIRCUIT

1. Turn ignition switch OFF.
2. Disconnect BCM.
3. Check continuity between BCM connector (A) and rear power window switch RH connector (B).

A		B		Continuity
Connector	Terminal	Connector	Terminal	
M20	68	D303	8	Yes

4. Check continuity between BCM connector (A) and ground.

A		Ground	Continuity
Connector	Terminal		
M20	68		No

OK or NG

OK >> GO TO 6.

NG >> Repair or replace harness.

6. CHECK REAR POWER WINDOW SWITCH RH GROUND SUPPLY

Check continuity between rear power window switch RH connector and ground.

Connector	Terminals	Continuity
D303	4	Yes
	5	Yes

OK or NG

OK >> Check the condition of the harness and the connector.

NG >> GO TO 7.

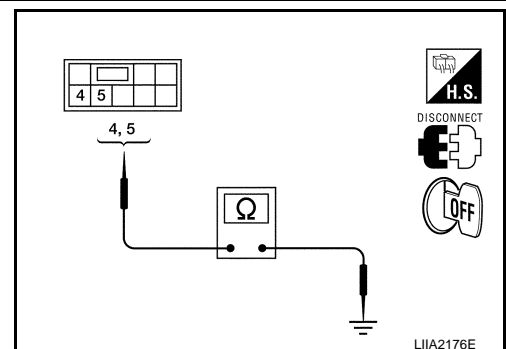

7. CHECK GROUND SUPPLY CIRCUIT

POWER WINDOW SYSTEM

< SERVICE INFORMATION >

1. Disconnect main power window and door lock/unlock switch.
2. Check continuity between main power window and door lock/unlock switch connector (A) and rear power window switch RH connector (B).

A		B		Continuity
Connector	Terminal	Connector	Terminal	
D5	7	D303	4	Yes
	5		5	Yes

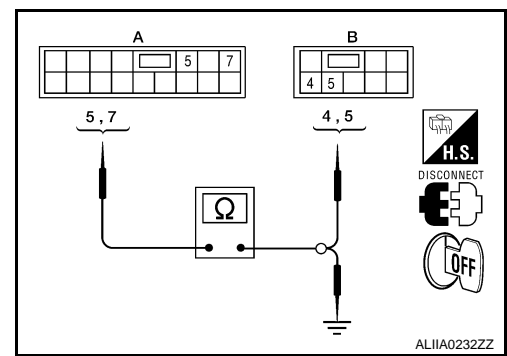

3. Check continuity between main power window and door lock/unlock switch connector (A) and ground.

A		Ground	Continuity
Connector	Terminal		
D5	7		No
	5		No

OK or NG

- OK >> GO TO 8.
- NG >> Repair or replace harness.

8. CHECK MAIN POWER WINDOW AND DOOR LOCK/UNLOCK SWITCH

Check continuity between main power window and door lock/unlock switch terminals.

Main power window and door lock/unlock switch	Terminals		Condition	Continuity
	17			
	7		Lock switch UNLOCK	Yes
			Lock switch LOCK	No
	5		Lock switch UNLOCK	Yes
			Lock switch LOCK	No

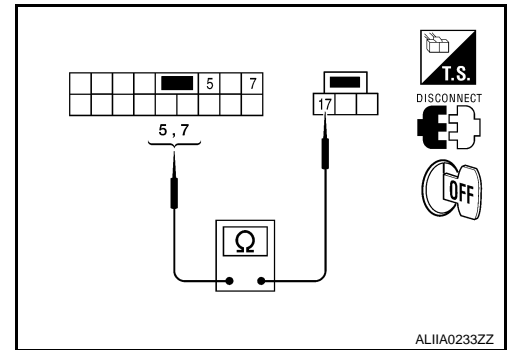

OK or NG

- OK >> Repair or replace harness.
- NG >> Replace main power window and door lock/unlock switch. Refer to [EI-30, "Removal and Installation"](#).

Rear Power Window RH Circuit Inspection (Main Power Window and Door Lock/Unlock Switch Operation)

INFOID:000000004409389

1. CHECK MAIN POWER WINDOW AND DOOR LOCK/UNLOCK SWITCH OUTPUT SIGNAL

1. Turn ignition switch OFF.
2. Disconnect rear power window motor RH.
3. Turn ignition switch ON.
4. Check voltage between rear power window motor RH connector and ground.

Connector	Terminals		Condition	Voltage (V) (Approx.)
	(+)	(-)		
D304	2	Ground	UP	0
			DOWN	Battery voltage
	1		UP	Battery voltage
			DOWN	0

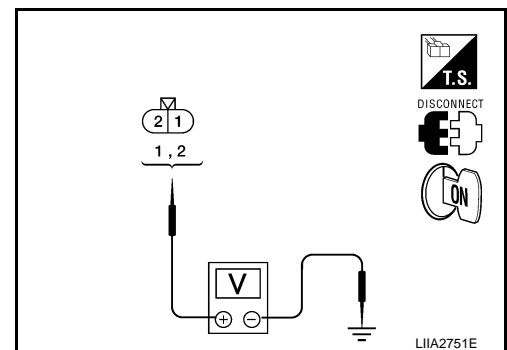

OK or NG

POWER WINDOW SYSTEM

< SERVICE INFORMATION >

- OK >> Replace rear power window motor RH. Refer to [GW-51, "Removal and Installation"](#).
- NG >> GO TO 2.

2. CHECK REAR POWER WINDOW MOTOR RH CIRCUIT

1. Turn ignition switch OFF.
2. Disconnect rear power window switch RH.
3. Check continuity between rear power window switch RH connector (A) and rear power window motor RH connector (B).

Connector	Terminal	Connector	Terminal	Continuity
A		B		
D303	6	D304	2	Yes
	7		1	Yes

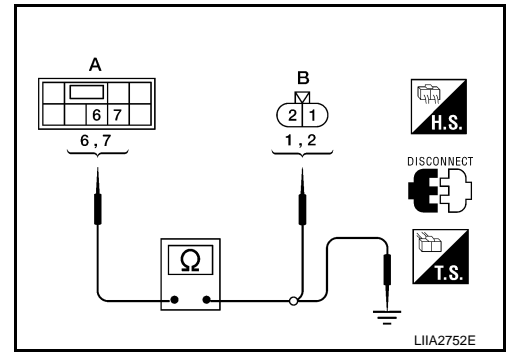

4. Check continuity between rear power window switch RH connector (A) and ground.

Connector	Terminal	Ground	Continuity
A			
D303	6	Ground	No
	7		No

OK or NG

- OK >> GO TO 3.
- NG >> Repair or replace harness.

3. CHECK REAR POWER WINDOW SWITCH RH

Check continuity between rear power window switch RH terminals.

Rear power window switch RH	Terminals		Continuity
	4	7	Yes
5	6	Yes	

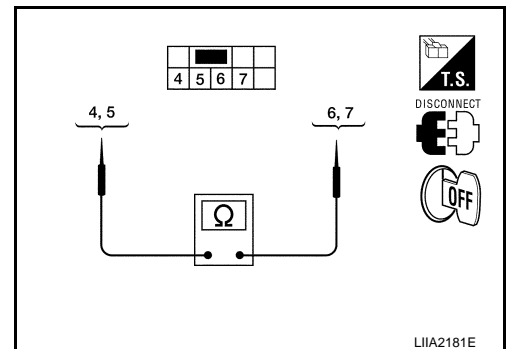

OK or NG

- OK >> GO TO 4.
- NG >> Replace rear power window switch RH. Refer to [EI-30, "Removal and Installation"](#).

4. CHECK GROUND SUPPLY CIRCUIT

1. Disconnect main power window and door lock/unlock switch.
2. Check continuity between main power window and door lock/unlock switch connector (A) and rear power window switch RH connector (B).

A		B		Continuity
Connector	Terminal	Connector	Terminal	
D5	7	D303	4	Yes
	5		5	Yes

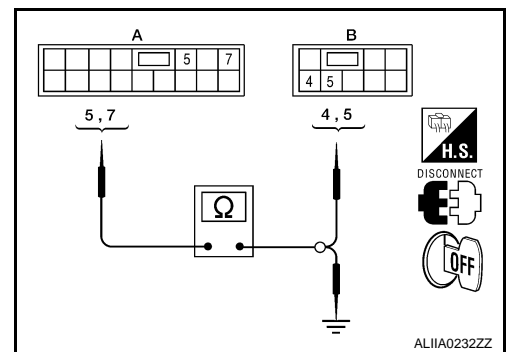

3. Check continuity between main power window and door lock/unlock switch connector (A) and ground.

POWER WINDOW SYSTEM

< SERVICE INFORMATION >

A		Ground	Continuity
Connector	Terminal		
D5	7		No
	5		No

OK or NG

- OK >> GO TO 5.
- NG >> Repair or replace harness.

5.CHECK MAIN POWER WINDOW AND DOOR LOCK/UNLOCK SWITCH

Check continuity between main power window and door lock/unlock switch terminals.

	Terminals		Condition	Continuity
	17			
Main power window and door lock/unlock switch	7	Lock switch UNLOCK	Yes	
		Lock switch LOCK	No	
	5	Lock switch UNLOCK	Yes	
		Lock switch LOCK	No	

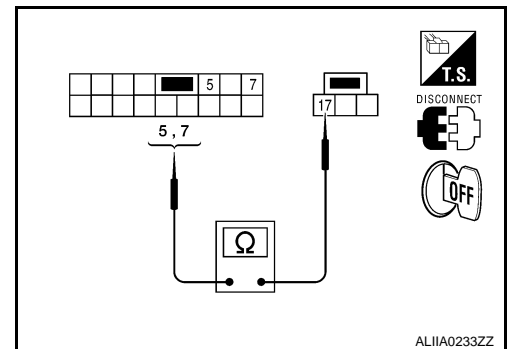

OK or NG

- OK >> Repair or replace harness.
- NG >> Replace main power window and door lock/unlock switch. Refer to [EI-30. "Removal and Installation"](#).

Encoder and Limit Switch Check

INFOID:000000004409390

1.CHECK DOOR WINDOW SLIDE MECHANISM

Check the following.

- Obstacles in window, glass molding, etc.
- Worn or deformed glass molding.
- Door sash tilted too far inward or outward.
- Door window regulator.

OK or NG

- OK >> GO TO 2.
- NG >> Remove obstacles or repair door window slide mechanism.

2.CHECK LIMIT SWITCH OPERATION

1. Turn ignition switch ON.
2. Check voltage between main power window and door lock/unlock switch connector D5 terminal 9 and ground.

Terminals		Condition	Voltage (Approx.)
(+)	(-)		
Connector	Terminal		
D5	9	Front power window LH is between fully-open and just before fully-closed position (ON)	0
		Front power window LH is between just before fully-closed position and fully-closed position (OFF)	5

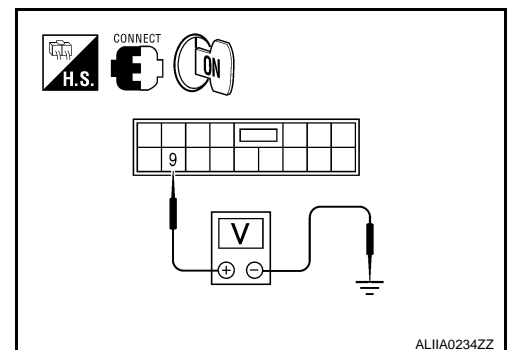

OK or NG

- OK >> GO TO 3.

POWER WINDOW SYSTEM

< SERVICE INFORMATION >

- NG >> Check harness between main power window and door lock/unlock switch and front power window motor LH.
- OK: Replace front power window motor LH.
 - NG: Replace or repair harness.

3.CHECK ENCODER

Measure voltage between main power window and door lock/unlock switch connector D5 terminal 13 and ground with oscilloscope when power window is in automatic closing operation.

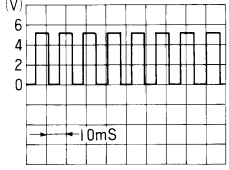
Terminals		Condition	Voltage
(+)	(-)		
D5	13	Front power window motor LH operation.	 <p>OCC3383D</p>

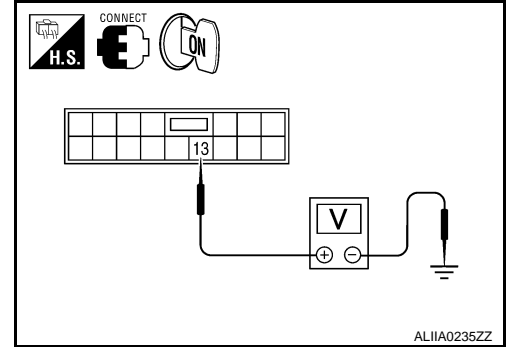

OK or NG

- OK >> Replace main power window and door lock/unlock switch.
- NG >> Replace front power window motor LH.

FRONT DOOR GLASS AND REGULATOR

< SERVICE INFORMATION >

FRONT DOOR GLASS AND REGULATOR

Removal and Installation

INFOID:000000004409391

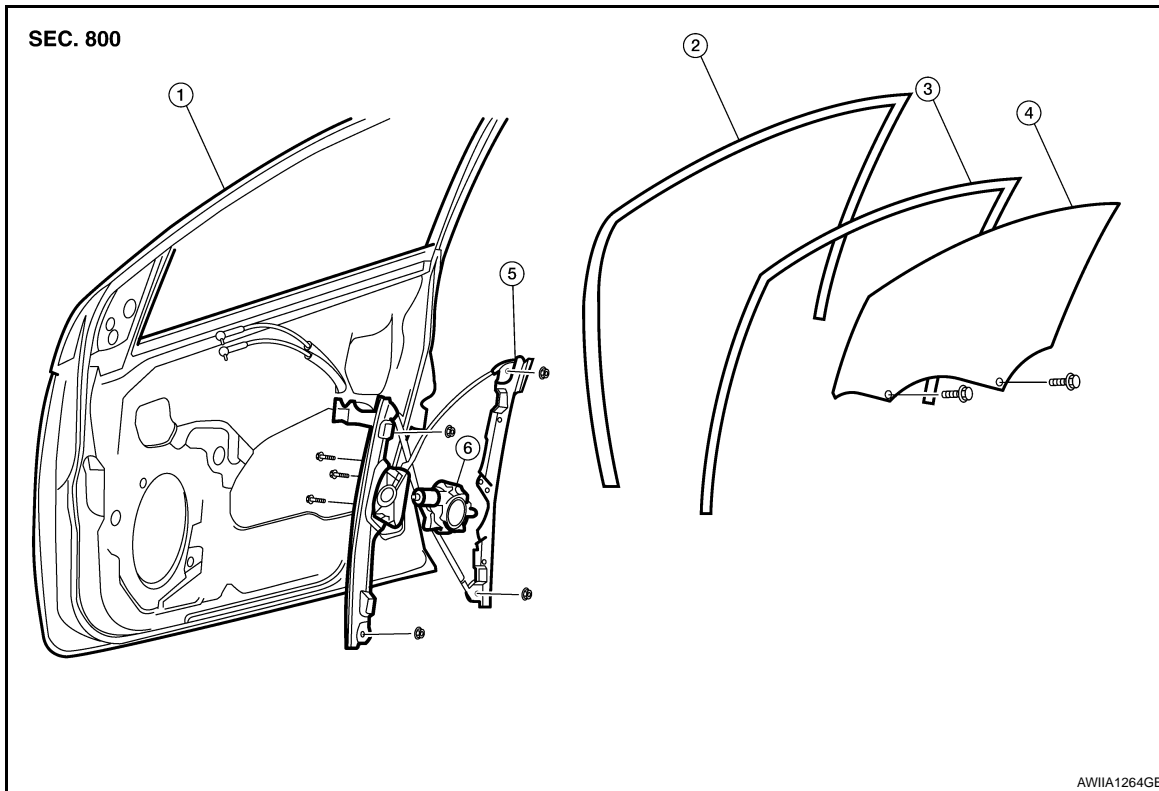

- | | | |
|---------------|-----------------------|-------------------------------------|
| 1. Door panel | 2. Door window sash | 3. Door glass run |
| 4. Door glass | 5. Regulator assembly | 6. Power window motor (if equipped) |

DOOR GLASS

Removal

1. Remove the front door finisher. Refer to [EI-30. "Removal and Installation"](#).
2. Disconnect the front door speaker electrical connector.
3. Position aside the sealing screen.
4. If equipped, reconnect the power window switch electrical connector. Operate the power window main switch to raise/lower the door window until the glass bolts can be seen.
5. Remove the door glass bolts.

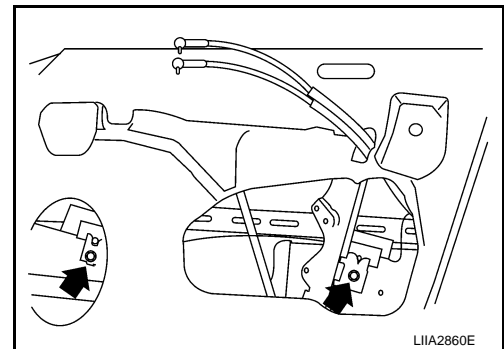

FRONT DOOR GLASS AND REGULATOR

< SERVICE INFORMATION >

6. While holding the door window, raise it at the rear end to pull the glass out of the sash toward the inside of the door.

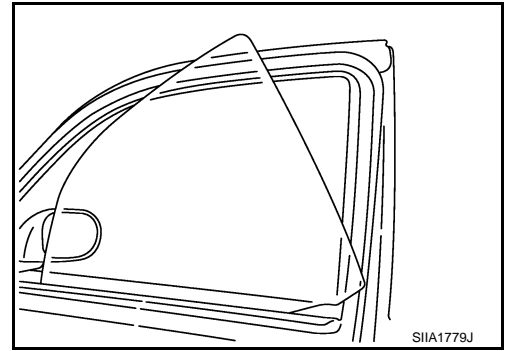

7. Remove the door glass run from the door panel.

Installation

Installation is in the reverse order of removal.

REGULATOR ASSEMBLY

Removal

1. Remove the front door finisher. Refer to [EI-30, "Removal and Installation"](#).
2. Disconnect the front door speaker electrical connector.
3. Position aside the sealing screen.
4. If equipped, reconnect the power window switch connector. Operate the power window main switch to raise/lower the door window until the door glass bolts can be seen.
5. Remove the door glass bolts.

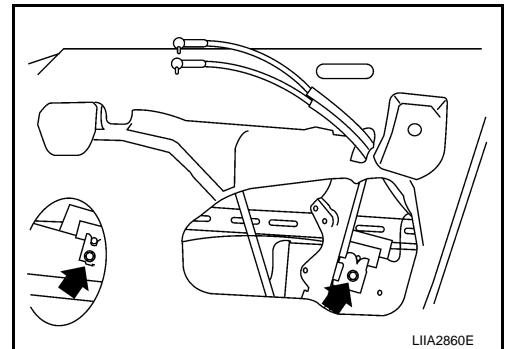

6. Raise the door glass and hold with a suction lifter (A).

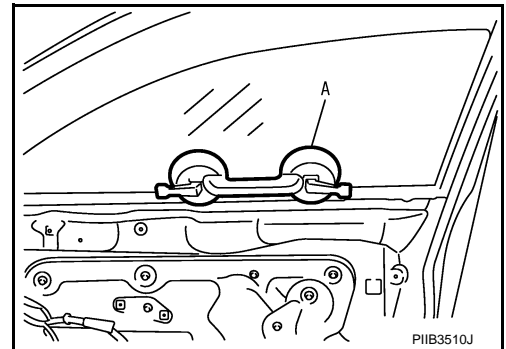

7. If equipped, disconnect the power window switch connector from the regulator assembly.
8. Remove the regulator bolts and regulator assembly.

FRONT DOOR GLASS AND REGULATOR

< SERVICE INFORMATION >

- If equipped remove bolt (A)

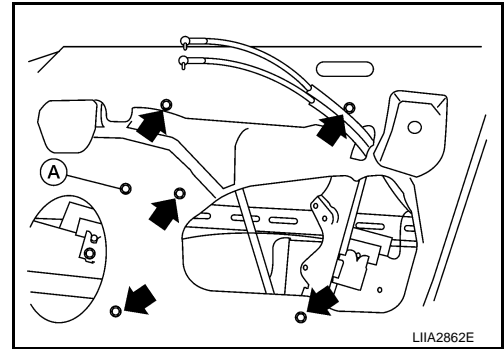

Inspection after Removal

Check the regulator assembly for the following. If a problem is detected, grease or replace it as shown.

- Grease application points for each sliding part

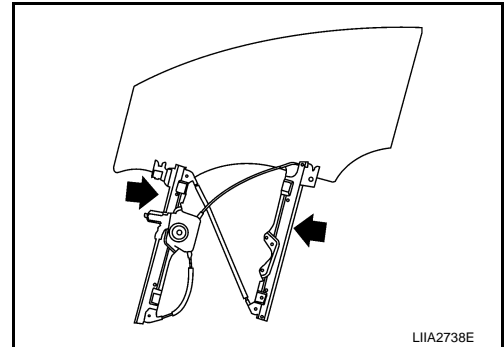

- Wire wear
- Regulator deformation

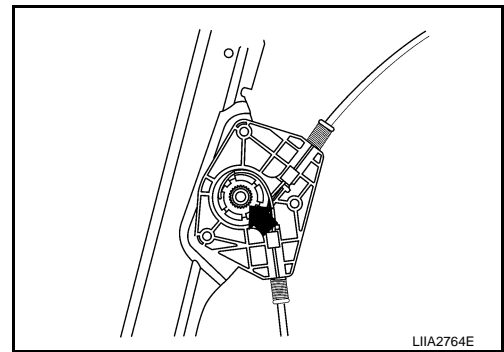

Installation

Installation is in the reverse order of removal.

Inspection after Installation

INFOID:000000004409392

POWER WINDOW SYSTEM INITIALIZATION

If any of the following work has been done, initialize the system.

- Electric power supply to power window switch or motor is interrupted by blown fuse or disconnecting battery cable, etc.
- Removal and installation of the regulator assembly.
- Removal and installation of the motor from the regulator assembly.
- Removal and installation of the harness connector of the power window switch.
- Operate the regulator assembly as a unit.
- Removal and installation of the door glass.
- Removal and installation of the door glass run.

Initialization

After installing each component to the vehicle, follow the steps below.

1. Disconnect the battery negative cable or disconnect power window switch's harness connector temporarily, then reconnect after at least 1 minute.
2. Turn ignition switch ON.

FRONT DOOR GLASS AND REGULATOR

< SERVICE INFORMATION >

3. Open the window to its full width by operating the power window switch. (Exclude this procedure if the window is already fully opened).
4. Move the power window switch in the up direction (auto close position) and hold. Keep holding the switch even when window is completely closed, and then release after 4 seconds.

NOTE:

Initialization may be cancelled with continuous opening and closing operation. In this case, initialize the system.

INSTALLED GLASS INSPECTION

- Make sure the glass is securely set into the glass run groove.
- Lower the glass slightly [approx. 10 to 20 mm (0.39 to 0.79 in)] and make sure the clearance to the sash is parallel. If the clearance between the glass and sash is not parallel, loosen the guide rail bolts, and the glass and guide rail bolts to correct the glass position.
- Make sure the system is normal with raising and lowering the glass.

Disassembly and Assembly

INFOID:000000004409393

POWER WINDOW REGULATOR ASSEMBLY

Disassembly

Remove the power window motor from the regulator assembly.

Assembly

Assembly is in the reverse order of disassembly.

REAR DOOR GLASS AND REGULATOR

< SERVICE INFORMATION >

REAR DOOR GLASS AND REGULATOR

Removal and Installation

INFOID:000000004409394

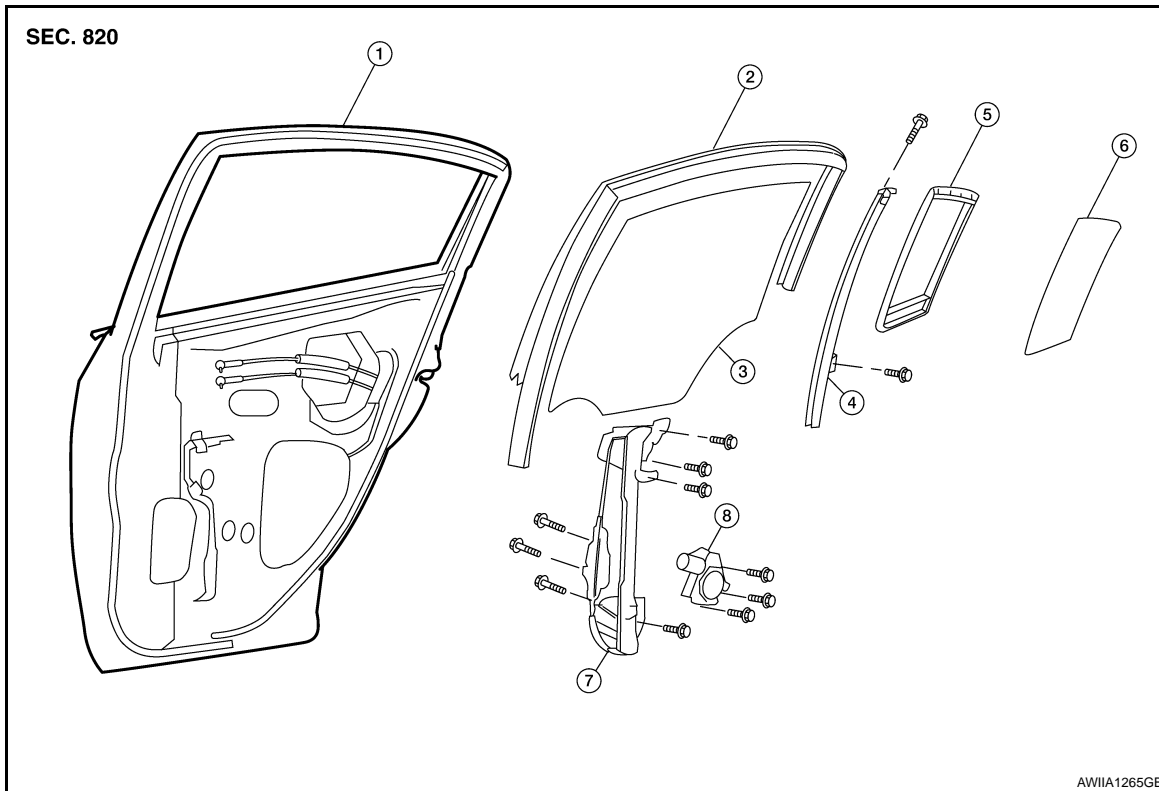

- | | | |
|-----------------------|-------------------------------------|--------------------|
| 1. Door panel | 2. Door glass run | 3. Door glass |
| 4. Partition sash | 5. Partition glass weatherstrip | 6. Partition glass |
| 7. Regulator assembly | 8. Power window motor (if equipped) | |

DOOR GLASS

Removal

1. Remove the rear door finisher. Refer to [EI-30. "Removal and Installation"](#).
2. Position aside the sealing screen.
3. Remove partition sash bolt and screw, pull the partition sash downward and tilt the upper end of the sash forward to pull the sash out upward.

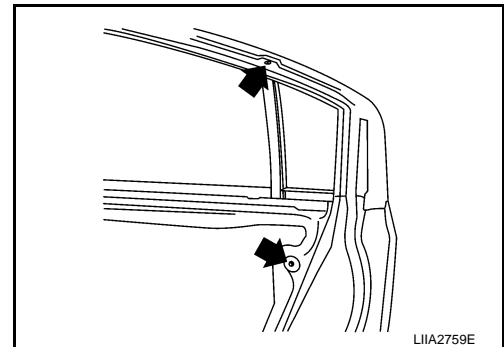

A
B
C
D
E
F
G
H
GW
J
K
L
M
N
O
P

REAR DOOR GLASS AND REGULATOR

< SERVICE INFORMATION >

4. Pull out the partition glass in the direction as shown.

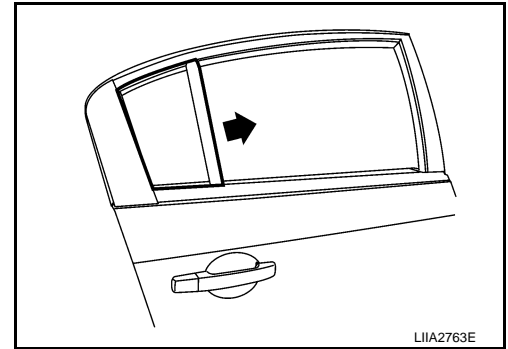

5. If equipped, reconnect the power window switch electrical connector. Operate the power window switch to raise/lower the door window until the glass bolts can be seen.
6. Remove the rear door glass bolts.
7. Pull out the rear door glass toward the outside of the door to remove.

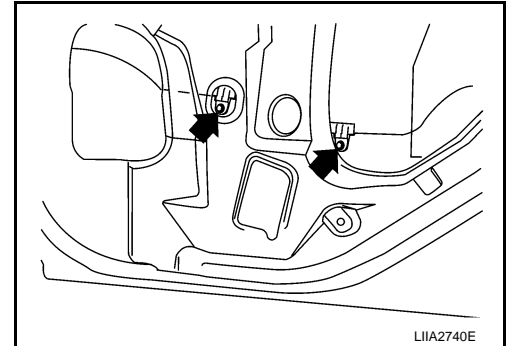

8. Remove the door glass run from the door panel.

Installation

Installation is in the reverse order of removal.

REGULATOR ASSEMBLY

Removal

1. Remove and position aside the rear door finisher. Refer to [EI-30, "Removal and Installation"](#).
2. Position aside the sealing screen.
3. If equipped, reconnect the power window switch electrical connector. Operate the power window switch to raise/lower the door window until the glass bolts can be seen.
4. Remove the rear door glass bolts.

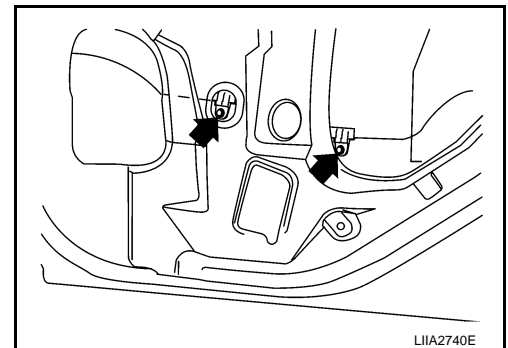

5. Raise up the door glass and hold with a suction lifter (A).

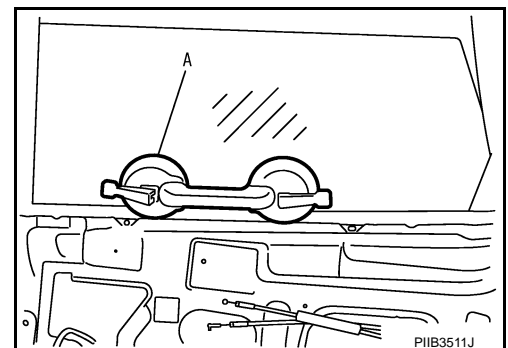

REAR DOOR GLASS AND REGULATOR

< SERVICE INFORMATION >

- Remove the regulator bolts, and then remove the regulator assembly from the door panel.

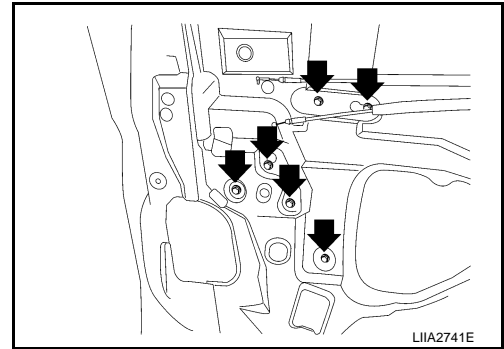

Installation

Installation is in the reverse order of removal.

Inspection after Removal

Check the regulator assembly for the following. If a problem is detected, grease or replace it as shown.

- Gear wear

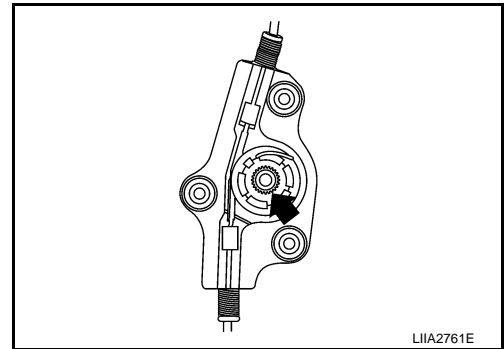

- Regulator deformation
- Grease application points for each sliding part

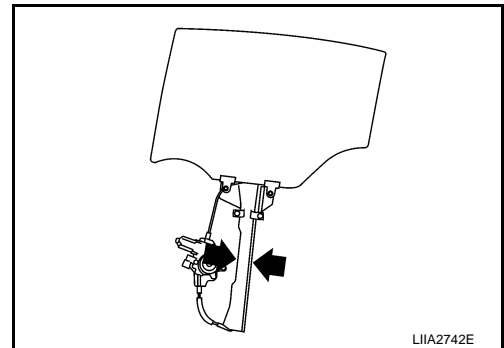

Disassembly and Assembly

INFOID:000000004409395

POWER WINDOW REGULATOR ASSEMBLY

Disassembly

Remove the power window motor from the regulator assembly.

Assembly

Assembly is in the reverse order of disassembly.

Inspection after Installation

INFOID:000000004409396

INSTALLED GLASS INSPECTION

- Make sure the glass is securely set into the glass run groove.
- Lower the glass slightly [approx. 10 to 20 mm (0.39 to 0.79 in)], and make sure the clearance to the sash is parallel. If the clearance between the glass and sash is not parallel, loosen the regulator bolts, guide rail bolts, and glass and carrier plate bolts to correct the glass position.

A
B
C
D
E
F
G
H
GW
J
K
L
M
N
O
P

REAR WINDOW DEFOGGER

< SERVICE INFORMATION >

REAR WINDOW DEFOGGER

Component Parts and Harness Connector Location

INFOID:000000004409397

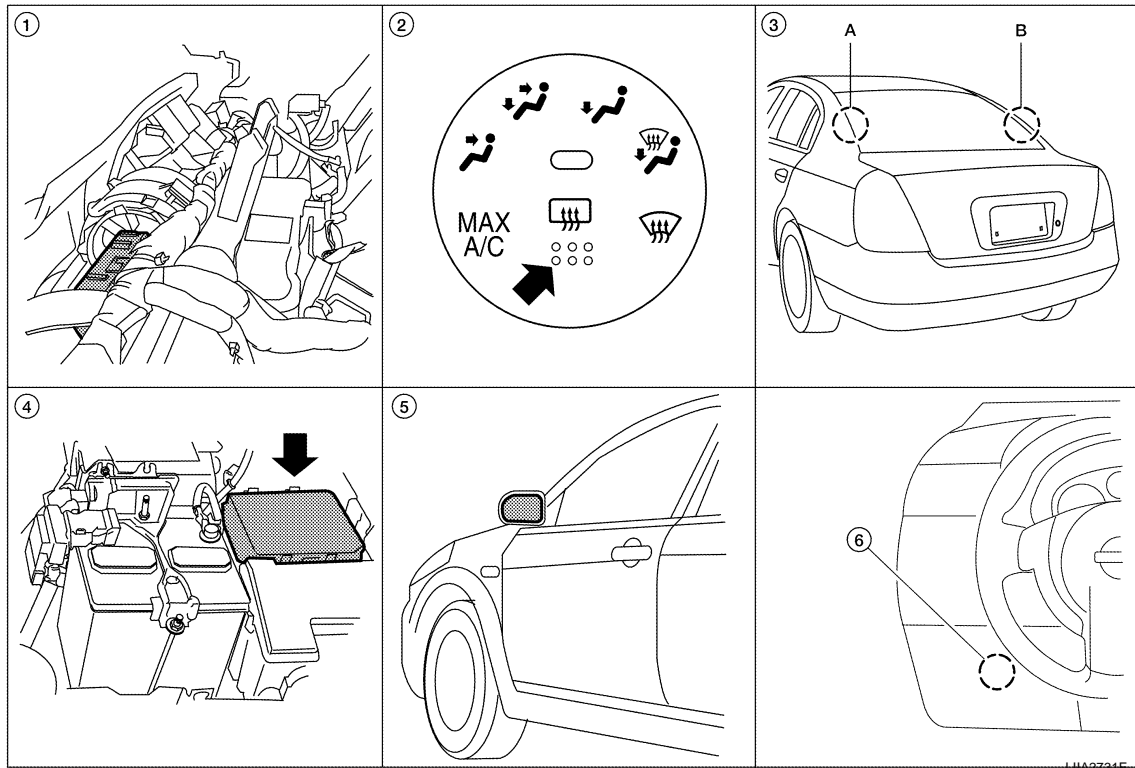

- | | | |
|--|---|--|
| 1. BCM M18, M20 (view with instrument panel removed) | 2. Front air control M33 | 3. A. Rear window defogger ground connector B63
B. Rear window defogger connector B50 |
| 4. IPDM E/R E46, E48 | 5. Door mirror LH D7, RH D106 (with heated mirrors) | 6. Heated mirror relay E56 (with heated mirrors) |

System Description

INFOID:000000004409398

The rear window defogger system is controlled by BCM (body control module) and IPDM E/R (intelligent power distribution module engine room).

The rear window defogger only operates for approximately 15 minutes.

Power is supplied at all times

- through 15A fuses (No. 46 and 47, located in the IPDM E/R)
- to rear window defogger relay
- through 10A fuse [No. 28 (with heated mirrors), located in the fuse and fusible link box]
- to heated mirror relay terminal 3 (with heated mirrors)
- through 50A fusible link (letter j, located in the fuse and fusible link box)
- to BCM terminal 70.

With the ignition switch turned to ON or START position, power is supplied

- through ignition relay
- to rear window defogger relay (located in the IPDM E/R)
- to front air control terminal 2
- through 10A fuse [No. 12, located in the fuse block (J/B)]
- to BCM terminal 38.

Ground is supplied

- to BCM terminal 67 and
- to front air control terminal 3
- through body grounds M57 and M61
- to IPDM E/R terminals 39 and 59

REAR WINDOW DEFOGGER

< SERVICE INFORMATION >

- through body grounds E9, E15 (all models) and E24 (with MR20DE).

When front air control (rear window defogger switch) is turned to ON, ground is supplied

- to BCM terminal 10
- through front air control terminal 38
- through front air control terminal 3
- through body grounds M57 and M61.

Then rear window defogger switch is illuminated.

Then BCM recognizes that rear window defogger switch is turned to ON.

Then it sends rear window defogger switch signals to IPDM E/R via CAN communication (CAN-H, CAN-L).

When IPDM E/R receives rear window defogger switch signals, ground is supplied

- to rear window defogger relay (located in the IPDM E/R)
- through IPDM E/R terminals 39 and 59
- through body grounds E9, E15 (all models) and E24 (with MR20DE).

Then rear window defogger relay is energized.

With power and ground supplied, rear window defogger filaments heat and defog the rear window.

When rear window defogger relay is turned to ON (with heated mirrors), power is supplied

- through heated mirror relay terminal 5
- to door mirror (LH and RH) terminal 1.

Door mirror (LH and RH) is grounded through body grounds M57 and M61.

With power and ground supplied, rear window defogger filaments heat and defog the rear window and door mirror filaments heat and defog the mirrors.

CAN Communication System Description

INFOID:000000004409399

Refer to [LAN-6, "System Description"](#).

A
B
C
D
E
F
G
H
J
K
L
M
N
O
P

GW

REAR WINDOW DEFOGGER

< SERVICE INFORMATION >

Schematic

INFOID:000000004409400

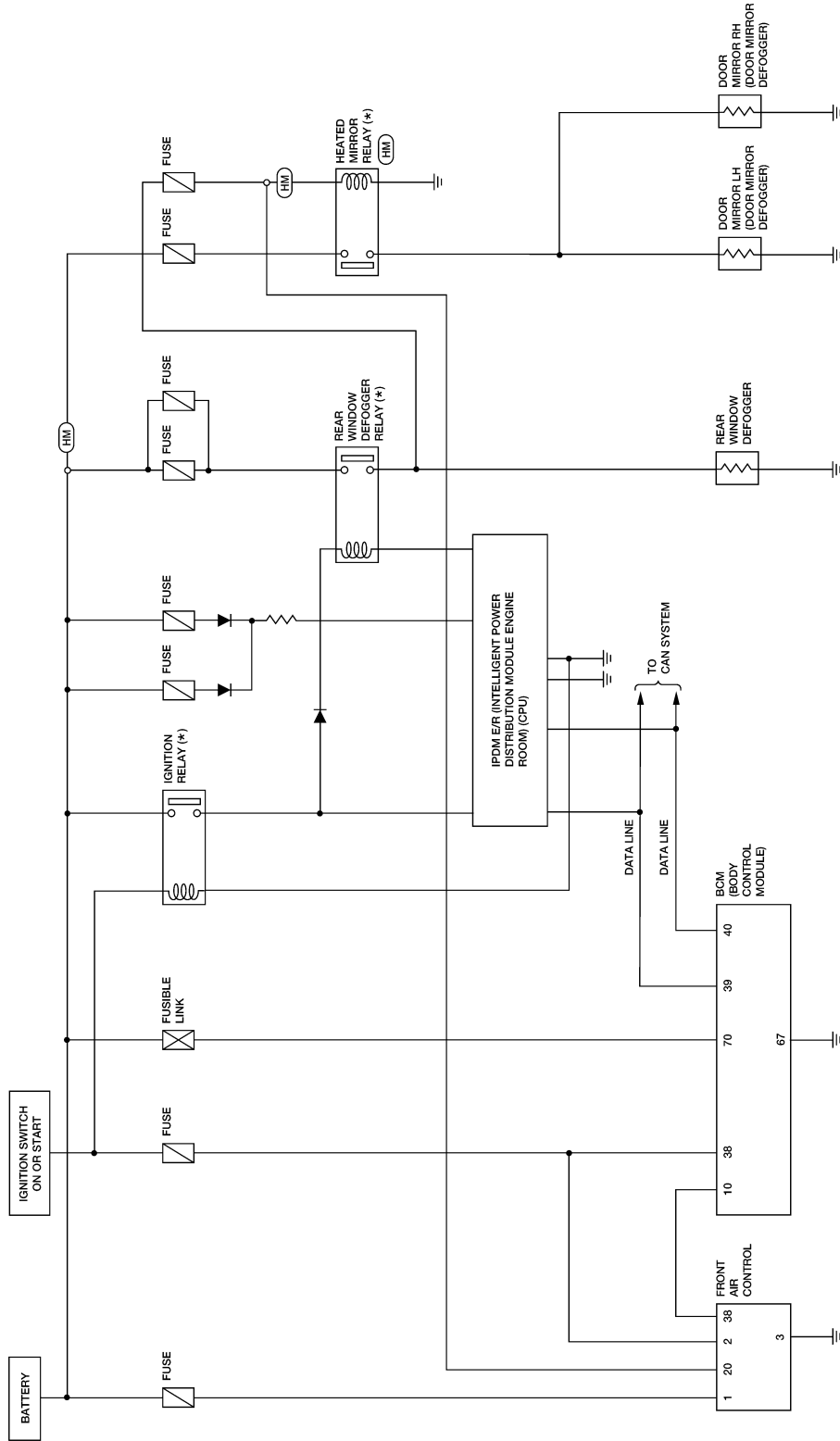

(HM) : WITH HEATED MIRRORS
 *: THIS RELAY IS BUILT INTO THE IPDM E/R
 (INTELLIGENT POWER DISTRIBUTION MODULE ENGINE ROOM)

WIWA2331E

REAR WINDOW DEFOGGER

< SERVICE INFORMATION >

Wiring Diagram - DEF -

INFOID:000000004409401

GW-DEF-01

— : DATA LINE

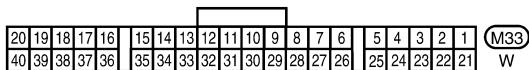
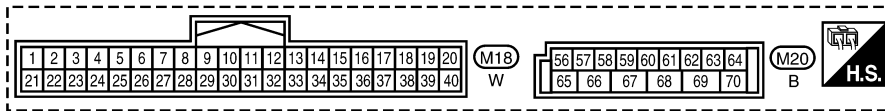
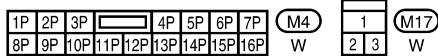
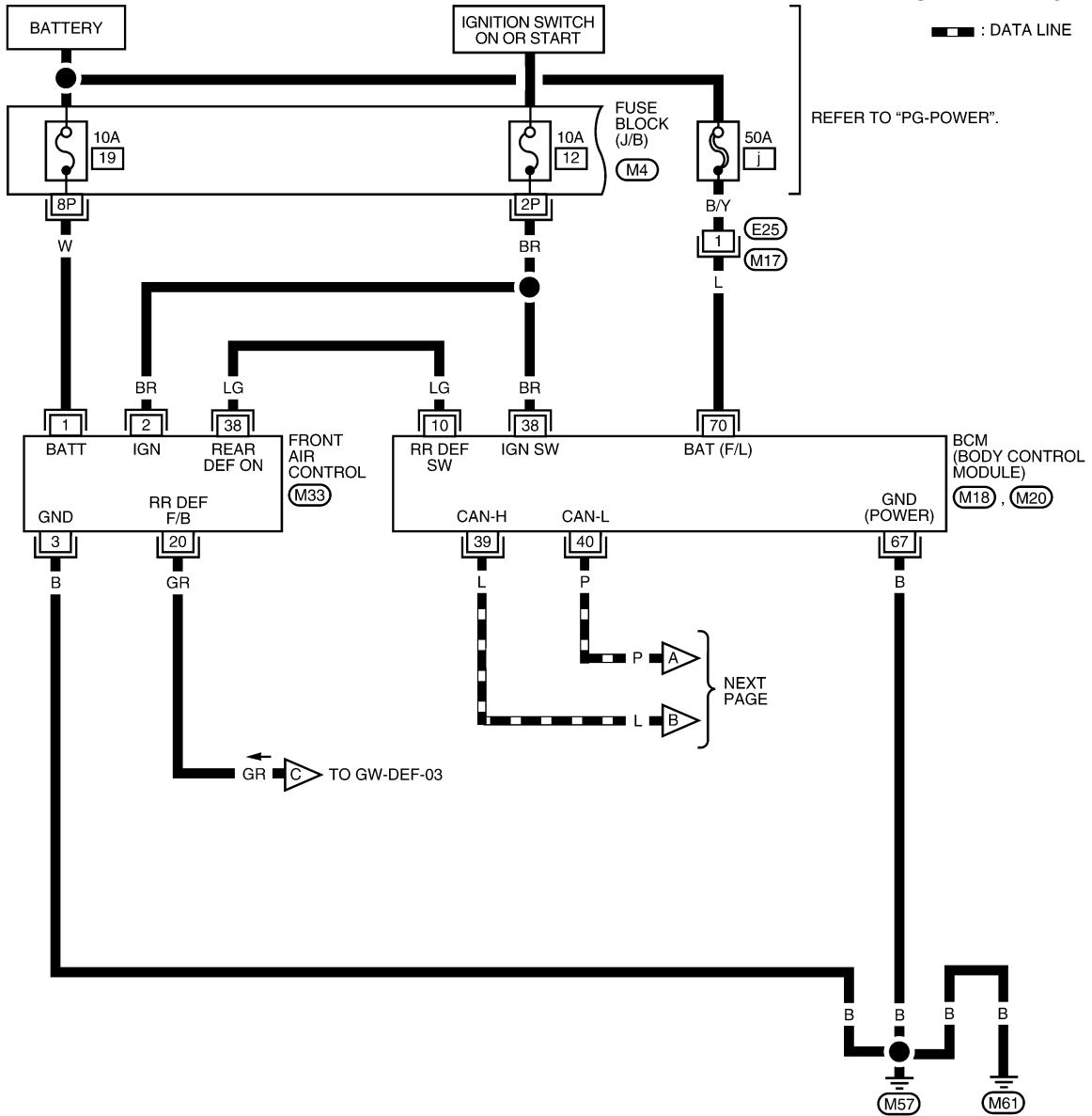

ABLWA0319GB

A
B
C
D
E
F
G
H
J
K
L
M
N
O
P

GW

REAR WINDOW DEFOGGER

< SERVICE INFORMATION >

GW-DEF-02

— : DATA LINE

MR : WITH MR20DE

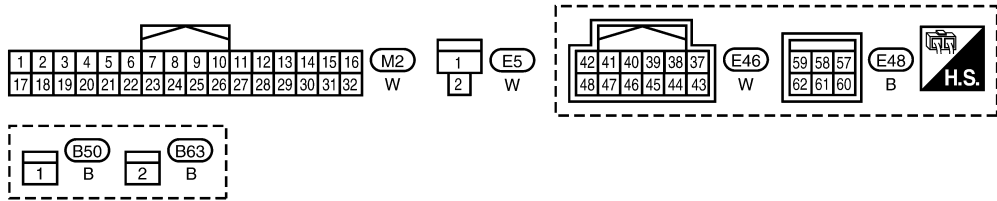
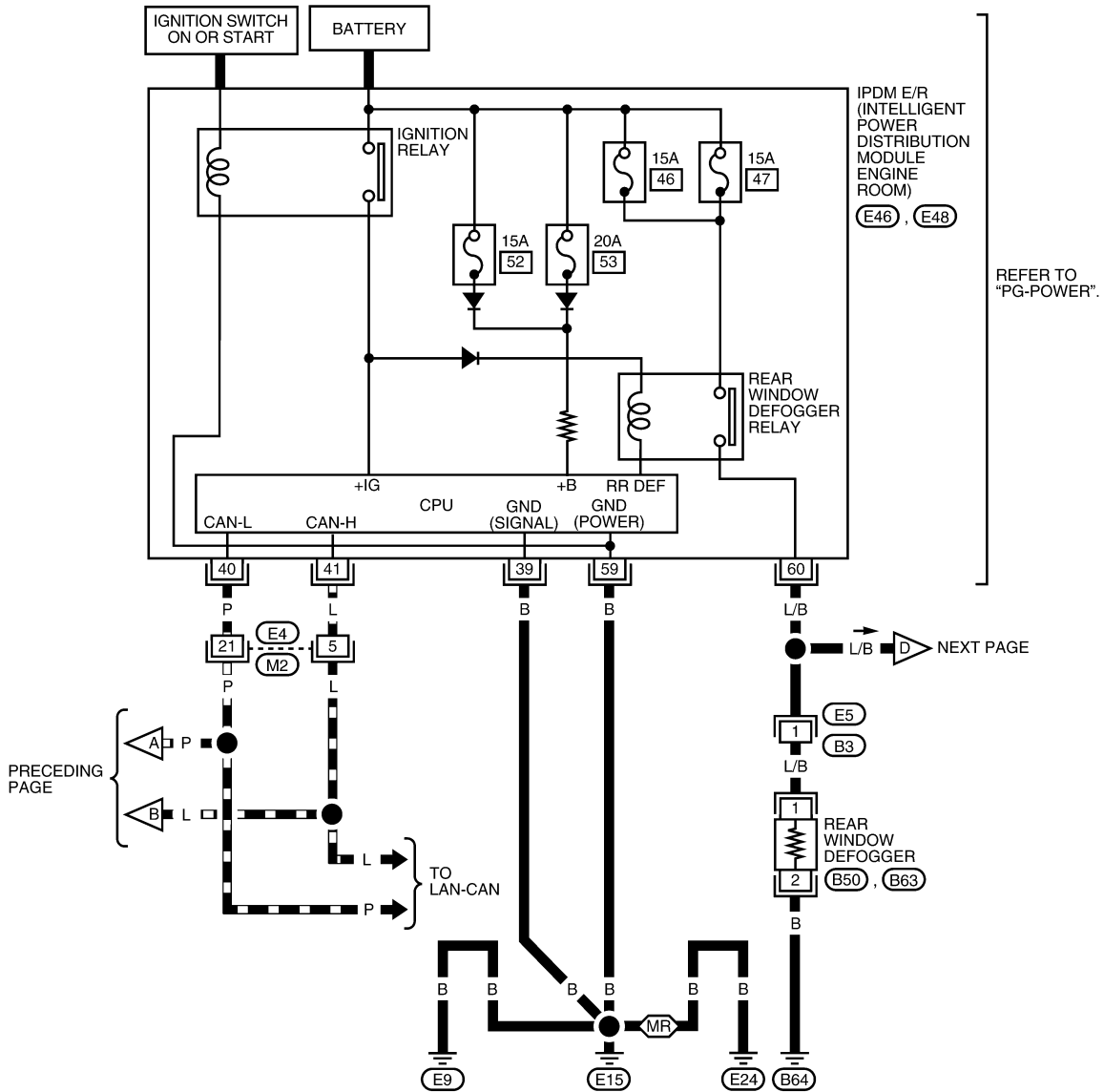

WIIWA2332E

REAR WINDOW DEFOGGER

< SERVICE INFORMATION >

GW-DEF-03

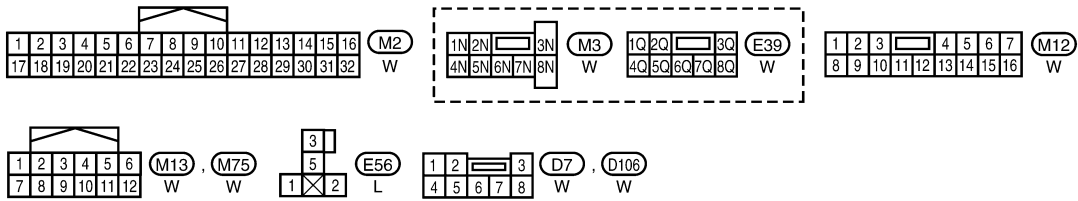
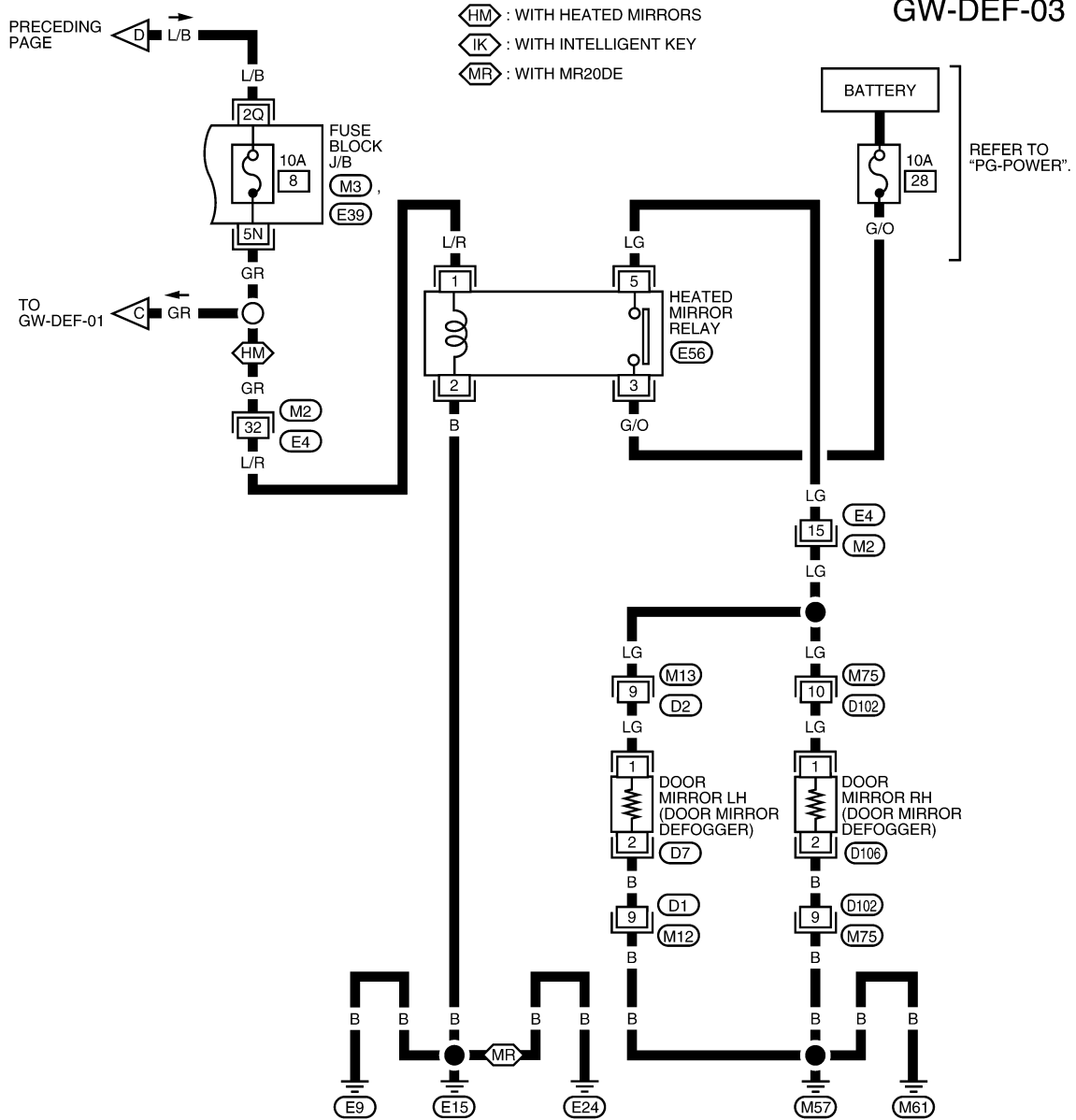

ABLWA0320GB

REAR WINDOW DEFOGGER

< SERVICE INFORMATION >

Terminal and Reference Value for BCM

INFOID:000000004409402

Refer to [BCS-11, "Terminal and Reference Value for BCM"](#).

Terminal and Reference Value for IPDM E/R

INFOID:000000004409403

Refer to [PG-24, "Terminal and Reference Value for IPDM E/R"](#).

Work Flow

INFOID:000000004409404

1. Check the symptom and customer's requests.
2. Understand the outline of system. Refer to [GW-54, "System Description"](#).
3. According to the trouble diagnosis chart, repair or replace the cause of the malfunction. Refer to [GW-60, "Trouble Diagnosis Symptom Chart"](#).
4. Does rear window defogger operate normally? YES: GO TO 5, NO: GO TO 3.
5. Inspection End.

CONSULT-III Function (BCM)

INFOID:000000004409405

CONSULT-III can display each diagnostic item using the diagnostic test modes shown following.

BCM diagnostic test item	Diagnostic mode	Content
Inspection by part	WORK SUPPORT	Supports inspections and adjustments. Commands are transmitted to the BCM for setting the status suitable for required operation, input/output signals are received from the BCM and received data is displayed.
	DATA MONITOR	Displays BCM input/output data in real time.
	ACTIVE TEST	Operation of electrical loads can be checked by sending drive signal to them.
	SELF-DIAG RESULTS	Displays BCM self-diagnosis results.
	CAN DIAG SUPPORT MNTR	The results of transmit/receive diagnosis of CAN communication can be read.
	ECU PART NUMBER	BCM part number can be read.
	CONFIGURATION	Performs BCM configuration read/write functions.

DATA MONITOR

Display Item List

Monitor item "Operation"	Content
REAR DEF SW	"ON/OFF" Indicates (ON/OFF) condition of the rear window defogger switch.
IGN ON SW	"ON/OFF" Indicates (ON/OFF) condition of the ignition switch signal.

ACTIVE TEST

Display Item List

Test item	Content
REAR WINDOW DEFOGGER	Gives a drive signal to the rear window defogger to activate it.

Trouble Diagnosis Symptom Chart

INFOID:000000004409406

Make sure other systems using the signal of the following systems operate normally.

REAR WINDOW DEFOGGER

< SERVICE INFORMATION >

Symptom	Diagnoses / Service procedure	Refer to page
Rear window defogger and door mirror defoggers do not operate. (With heated mirrors)	1. BCM power supply and ground circuit check	BCS-14
	2. IPDM E/R auto active test check	PG-20
	3. Rear window defogger switch circuit check	GW-61
	4. Replace IPDM E/R	PG-27
Rear window defogger does not operate. (Without heated mirrors)	1. BCM power supply and ground circuit check	BCS-14
	2. IPDM E/R auto active test check	PG-20
	3. Rear window defogger switch circuit check	GW-61
	4. Rear window defogger circuit check	GW-62
	5. Filament check	GW-66
	6. Replace IPDM E/R	PG-27
Rear window defogger does not operate but both door mirror defoggers operate. (With heated mirrors)	1. Rear window defogger circuit check	GW-62
	2. Filament check	GW-66
Door mirror defoggers do not operate but rear window defogger operates. (With heated mirrors)	1. Door mirror defogger circuit check	GW-64
Rear window defogger switch does not light, but rear window defogger operates.	1. Replace front air control	MTC-65

BCM Power Supply and Ground Circuit Inspection

INFOID:000000004409407

Refer to [BCS-14](#), "BCM Power Supply and Ground Circuit Inspection".

Rear Window Defogger Switch Circuit Inspection

INFOID:000000004409408

1. CHECK REAR WINDOW DEFOGGER SWITCH OPERATION

With CONSULT-III

Check ("REAR DEF SW", "IGN ON SW") in DATA MONITOR mode with CONSULT-III.

When rear window defogger switch is turned to ON

REAR DEF SW : ON

When ignition switch is turned to ON

IGN ON SW : ON

Without CONSULT-III

- Turn ignition switch ON.
- Check voltage between BCM connector and ground.

Connector	Terminals		Condition	Voltage (V) (Approx.)
	(+)	(-)		
M18	10	Ground	Rear window defogger switch is pressed	0
			Rear window defogger switch is released	5

OK or NG

OK >> Rear window defogger switch check is OK.

NG >> GO TO 2.

2. CHECK REAR WINDOW DEFOGGER SWITCH CIRCUIT HARNESS CONTINUITY

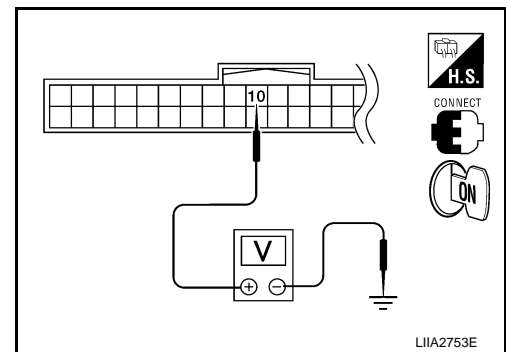

REAR WINDOW DEFOGGER

< SERVICE INFORMATION >

1. Turn ignition switch OFF.
2. Disconnect BCM and front air control.
3. Check continuity between BCM connector M18 (A) terminal 10 and front air control connector M33 (B) terminal 38.

10 - 38 : Continuity should exist.

4. Check continuity between BCM connector M18 (A) terminal 10 and ground

10 - Ground : Continuity should not exist.

OK or NG

- OK >> GO TO 3.
- NG >> Repair or replace harness.

3.CHECK REAR WINDOW DEFOGGER SWITCH

Check continuity between front air control terminals.

Terminals	Condition	Continuity
38 3	Rear window defogger switch is ON (pressed)	Yes
	Rear window defogger switch is OFF (released)	No

OK or NG

- OK >> GO TO 4.
- NG >> Replace front air control. Refer to [MTC-65, "Removal and Installation"](#).

4.CHECK REAR WINDOW DEFOGGER SWITCH GROUND

Check continuity between front air control connector and ground.

Connector	Terminal	Ground	Continuity
M33	3		Yes

OK or NG

- OK >> GO TO 5.
- NG >> Repair or replace harness.

5.CHECK BCM OUTPUT SIGNAL

1. Connect BCM.
2. Turn ignition switch ON.
3. Check voltage between BCM connector M18 terminal 10 and ground.

10 - Ground : Approx. 5V

OK or NG

- OK >> Replace front air control. Refer to [MTC-65, "Removal and Installation"](#).
- NG >> Replace BCM. Refer to [BCS-17, "Removal and Installation of BCM"](#).

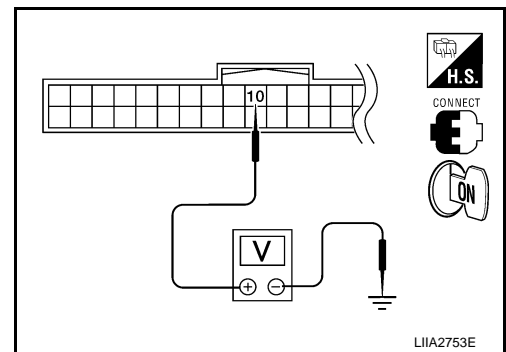
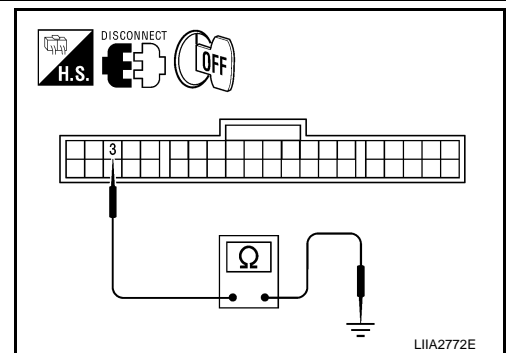
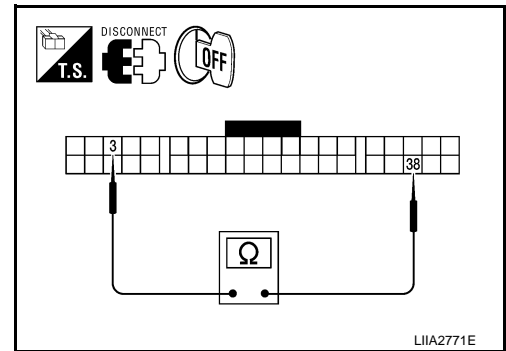
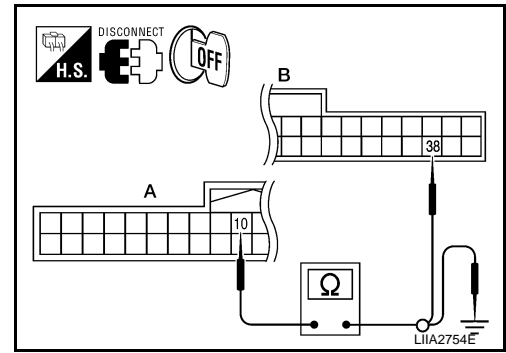

Rear Window Defogger Circuit Inspection

INFOID:000000004409409

1.CHECK FUSES

REAR WINDOW DEFOGGER

< SERVICE INFORMATION >

Check if any of the following fuses in IPDM E/R are blown.

Component Parts	Ampere	Fuse No.
IPDM E/R	15A	46
IPDM E/R	15A	47

OK or NG

OK >> GO TO 2.

NG >> If fuse is blown, be sure to eliminate cause of malfunction before installing new fuse.

2. CHECK REAR WINDOW DEFOGGER POWER SUPPLY CIRCUIT

- Turn ignition switch OFF.
- Disconnect rear window defogger.
- Turn ignition switch ON.
- Check voltage between rear window defogger connector and ground.

Connector	Terminals		Condition	Voltage (V) (Approx.)
	(+)	(-)		
B50	1	Ground	Rear window defogger switch ON	Battery voltage
			Rear window defogger switch OFF	0

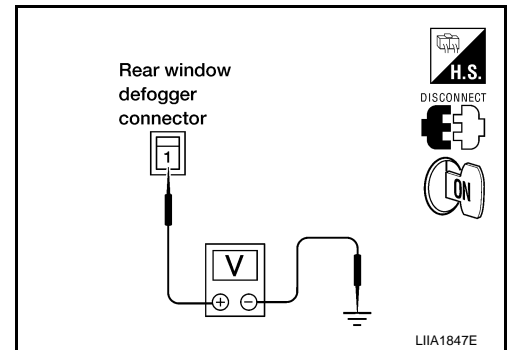

OK or NG

OK >> GO TO 3.

NG >> GO TO 4.

3. CHECK REAR WINDOW DEFOGGER GROUND CIRCUIT

- Turn ignition switch OFF.
- Check continuity between rear window defogger connector B63 terminal 2 and ground.

2 - Ground : Continuity should exist.

OK or NG

- OK >> Check filament. Refer to [GW-66, "Filament Check"](#).
- If filament is OK. Check the condition of the harness and the connector.
 - If filament is NG. Repair filament. Refer to [GW-67, "Filament Repair"](#).

NG >> Repair or replace harness.

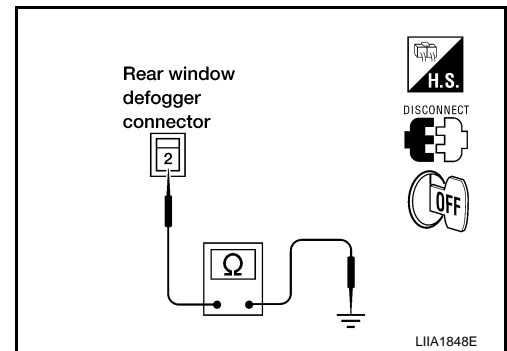

4. CHECK HARNESS CONTINUITY

- Disconnect IPDM E/R.
- Check continuity between rear window defogger connector (A) and IPDM E/R connector (B).

A		B		Continuity
Connector	Terminal	Connector	Terminal	
B50	1	E48	60	Yes

- Check continuity between rear window defogger connector (A) and ground.

A		Ground	Continuity
Connector	Terminal		
B50	1		No

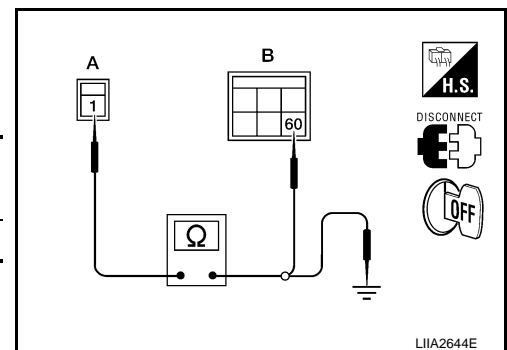

REAR WINDOW DEFOGGER

< SERVICE INFORMATION >

OK or NG

- OK >> GO TO 5.
- NG >> Repair or replace harness.

5.CHECK REAR WINDOW DEFOGGER RELAY OUTPUT SIGNAL

1. Connect IPDM E/R.
2. Turn ignition switch ON.
3. Check voltage between IPDM E/R connector and ground.

Connector	Terminals		Condition	Voltage (V) (Approx.)
	(+)	(-)		
E48	60	Ground	Rear window defogger switch ON	Battery voltage
			Rear window defogger switch OFF	0

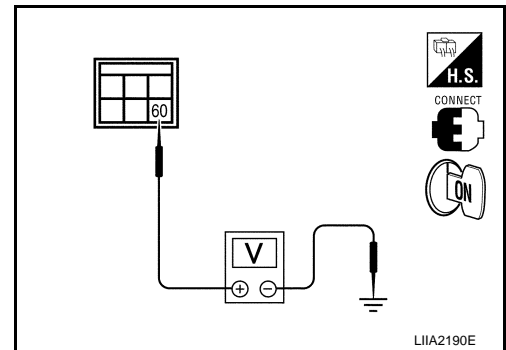

OK or NG

- OK >> Check condition of harness and connector.
- NG >> Replace IPDM E/R. Refer to [PG-27. "Removal and Installation of IPDM E/R"](#).

Door Mirror Defogger Circuit Inspection

INFOID:000000004409410

1.CHECK FUSE

Check if the following fuse in the fuse block (J/B) is blown.

Component Parts	Ampere	Fuse No.
Fuse block (J/B)	10A	8

OK or NG

- OK >> GO TO 2.
- NG >> If fuse is blown, be sure to eliminate cause of malfunction before installing new fuse.

2.CHECK HEATED MIRROR RELAY POWER SUPPLY CIRCUIT

1. Disconnect heated mirror relay.
2. Turn ignition switch ON.
3. Check voltage between heated mirror relay connector and ground.

Connector	Terminals		Voltage (V) (Approx.)
	(+)	(-)	
E56	1	Ground	Battery voltage
	3		

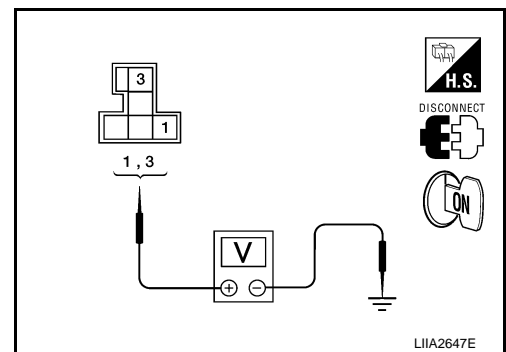

OK or NG

- OK >> GO TO 3.
- NG >> Repair or replace harness.

3.CHECK HEATED MIRROR RELAY GROUND CIRCUIT

REAR WINDOW DEFOGGER

< SERVICE INFORMATION >

1. Turn ignition switch OFF.
2. Check continuity between heated mirror relay connector E56 terminal 2 and ground.

2 - Ground : Continuity should exist.

OK or NG

- OK >> GO TO 4.
 NG >> Repair or replace harness.

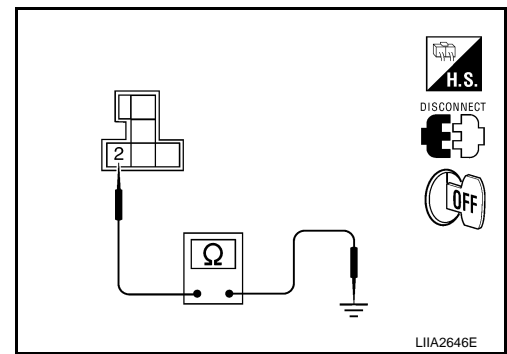

4.INSPECTION OF HEATED MIRROR RELAY

Check continuity between heated mirror relay terminals 3 and 5.

Condition	Continuity
12V direct current supply between terminals 1 and 2	Yes
No current supply	No

OK or NG

- OK >> GO TO 5.
 NG >> Replace heated mirror relay.

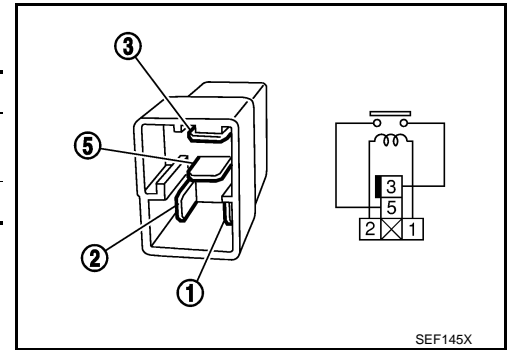

5.CHECK HARNESS CONTINUITY

1. Disconnect door mirror (LH or RH).
2. Check continuity between door mirror LH or RH connector (A) and heated mirror relay connector (B).

Connector	Terminal	Connector	Terminal	Continuity
A		B		
D7 (LH)	1	E56	5	Yes
D106 (RH)				

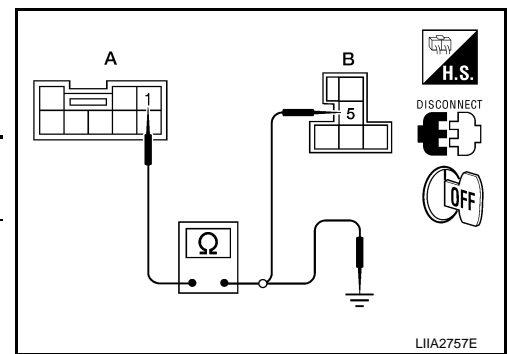

3. Check continuity between door mirror LH or RH connector (A) and ground.

A		Ground	Continuity
Connector	Terminal		
D7 (LH)	1	Ground	No
D106 (RH)			

OK or NG

- OK >> GO TO 6.
 NG >> Repair or replace harness.

6.CHECK GROUND CIRCUIT

A
B
C
D
E
F
G
H
J
K
L
M
N
O
P

GW

REAR WINDOW DEFOGGER

< SERVICE INFORMATION >

Check continuity between door mirror LH or RH connector and ground.

Connector	Terminals		Continuity
D4 (LH)	2	Ground	Battery voltage
D106 (RH)			

OK or NG

- OK >> Replace door mirror (LH or RH). Refer to [GW-70](#), "[Removal and Installation](#)".
- NG >> Repair or replace harness.

Filament Check

INFOID:000000004409411

- When measuring voltage, wrap tin foil around the top of the negative probe. Then press the foil against the wire with your finger.

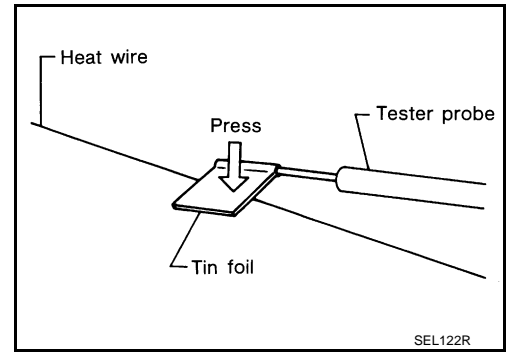

- Attach probe circuit tester (in Volt range) to middle portion of each filament.

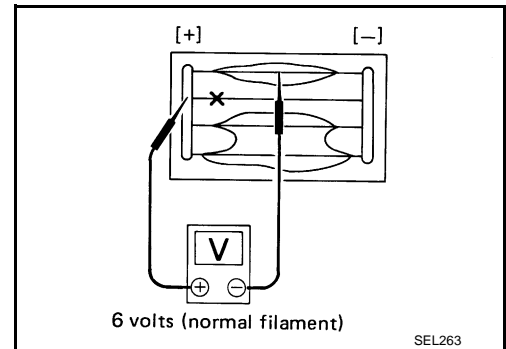

REAR WINDOW DEFOGGER

< SERVICE INFORMATION >

- If a filament is burned out, circuit tester registers 0 or battery voltage.
- To locate burned out point, move probe to left and right along filament. Test needle will swing abruptly when probe passes the point.

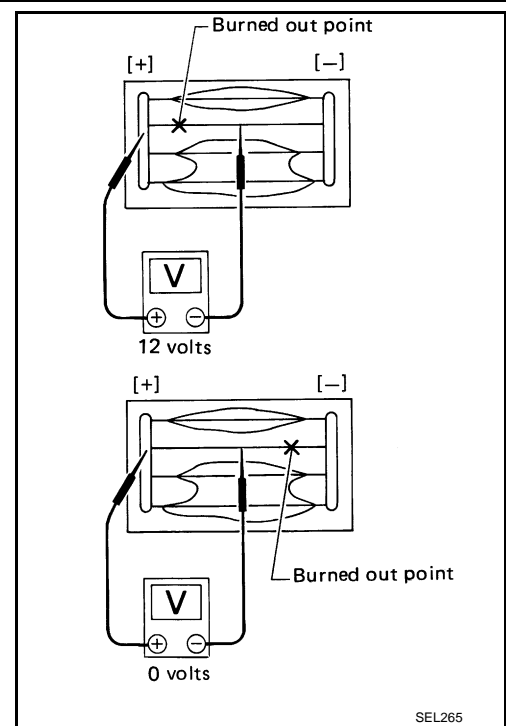

Filament Repair

INFOID:000000004409412

REPAIR EQUIPMENT

- Conductive silver composition (DuPont No. 4817 or equivalent)
- Ruler 30 cm (11.8 in) long
- Drawing pen
- Heat gun
- Alcohol
- Cloth

REPAIRING PROCEDURE

- Wipe broken heat wire and its surrounding area clean with a cloth dampened in alcohol.
- Apply a small amount of conductive silver composition to tip of drawing pen. Shake silver composition container before use.
- Place ruler on glass along broken line. Deposit conductive silver composition on break with drawing pen. Slightly overlap existing heat wire on both sides [preferably 5 mm (0.20 in)] of the break.

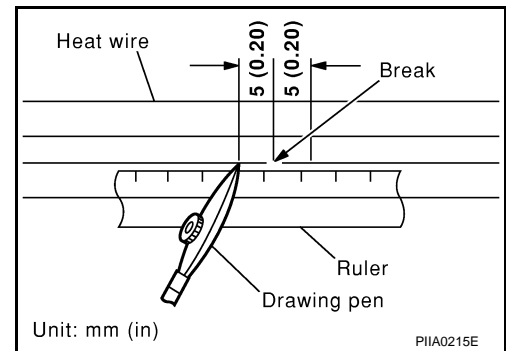

- After repair has been completed, check repaired wire for continuity. This check should be conducted 10 minutes after silver composition is deposited. Do not touch repaired area while test is being conducted.

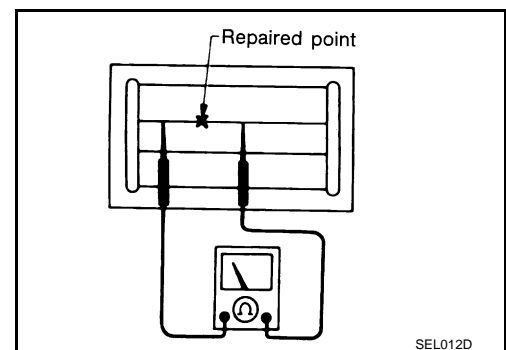

A
B
C
D
E
F
G
H
J
K
L
M
N
O
P

GW

REAR WINDOW DEFOGGER

< SERVICE INFORMATION >

5. Apply a constant stream of hot air directly to the repaired area for approximately 20 minutes with a heat gun. A minimum distance of 3 cm (1.2 in) should be kept between repaired area and hot air outlet.
If a heat gun is not available, let the repaired area dry for 24 hours.

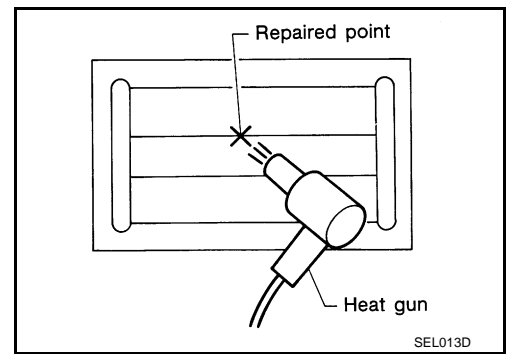

DOOR MIRROR

< SERVICE INFORMATION >

DOOR MIRROR

Wiring Diagram - MIRROR -

INFOID:000000004409413

GW-MIRROR-01

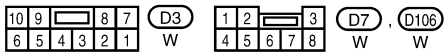
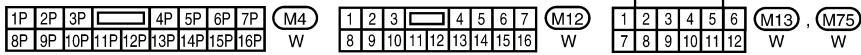
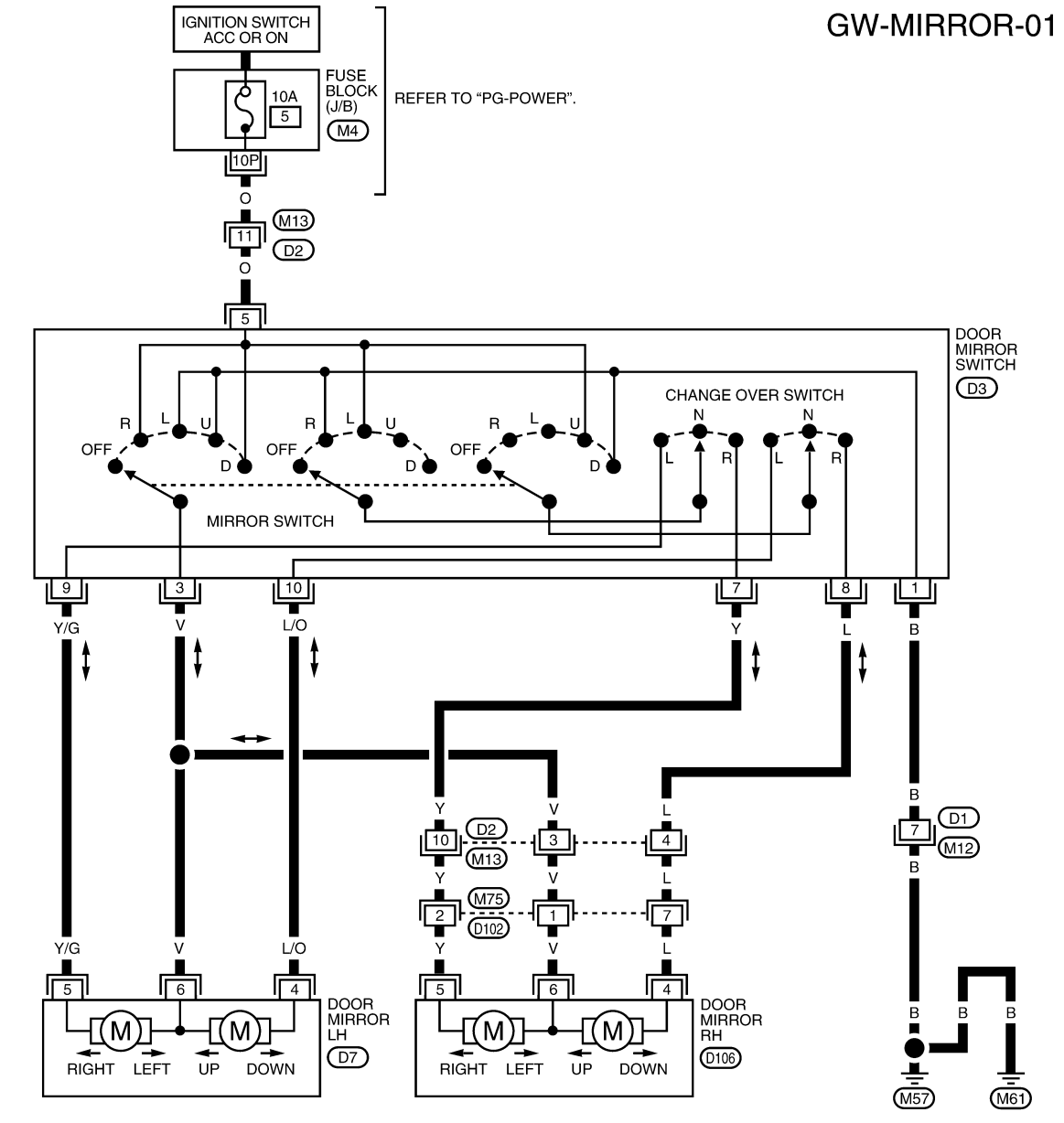

AWKWA0118GI

A
B
C
D
E
F
G
H
I
J
K
L
M
N
O
P

GW

DOOR MIRROR

< SERVICE INFORMATION >

Removal and Installation

INFOID:000000004409414

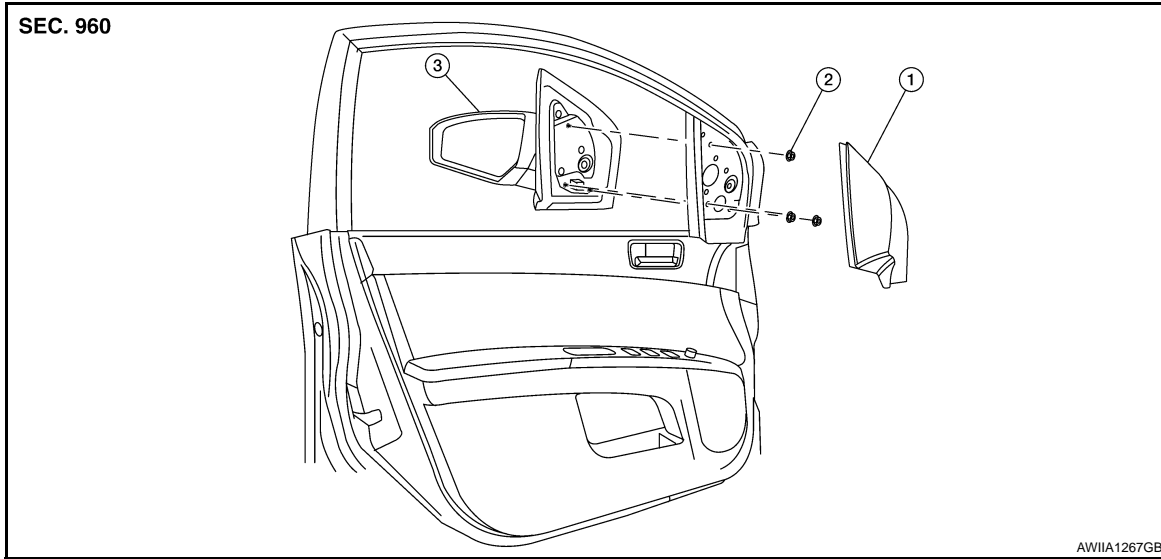

1. Mirror finisher

2. Nut

3. Door Mirror

CAUTION:

Be careful not to damage the mirror body.

REMOVAL

1. Remove the mirror finisher.
2. Remove the front door finisher. Refer to [EI-30. "Removal and Installation"](#).
3. Disconnect the door mirror connector (2), remove the door mirror nuts (A), and remove the door mirror assembly (1).

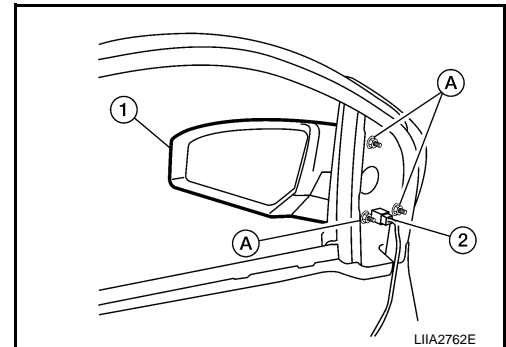

INSTALLATION

Installation is in the reverse order of removal.

Disassembly and Assembly

INFOID:000000004409415

DISASSEMBLY

1. Pull out all the terminals from the connector.
NOTE:
Before pulling out the terminal, note the connector terminal arrangement.

2. Turn the mirror glass surface upward.
3. Apply a protective tape (A) to the housing.
4. Insert a suitable tool (B) into the concave gap between mirror holder (1) and power unit (2). Push up tabs (3) (two locations) on mirror holder to disengage lower part of mirror holder, and remove mirror body assembly.

NOTE:

When pushing up the tabs, do not forcefully push up only (1) concave position but try to push up (2) concave positions.

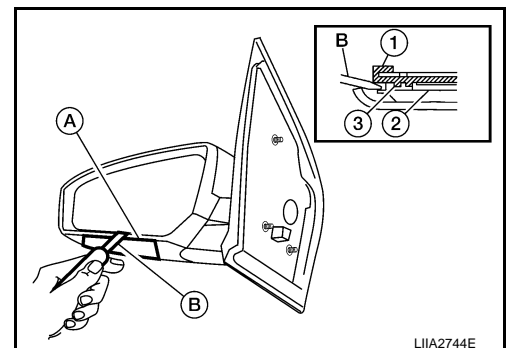

DOOR MIRROR

< SERVICE INFORMATION >

5. Remove the mirror body (1) from the mirror housing assembly (2).
6. Remove four screws from door mirror actuator in an alternating pattern.
7. Remove door mirror actuator from mirror housing assembly and disconnect electrical connector.

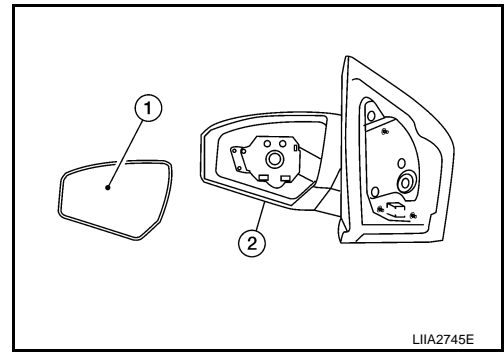

ASSEMBLY

1. Connect door mirror actuator electrical connector.
2. Install door mirror actuator into door mirror housing using four screws and tighten in an alternating pattern.
3. Warm the lower tabs with a dryer or equivalent.

NOTE:

Warm the lower tabs sufficiently before installing the mirror body. The tabs may be broken if it is cold. Be especially careful in the cold weather.

4. Engage upper tabs of mirror body (1) with power unit (2). Then, press lower part of mirror glass down until the lower part snaps to allow engagement of lower tabs.

NOTE:

After installation, visually check that the lower tabs are securely engaged when viewed from the bottom of mirror surface.

5. Insert the harness terminals into the connector.

NOTE:

Make sure to insert the harness terminals into the correct connector. Do not confuse the locations.

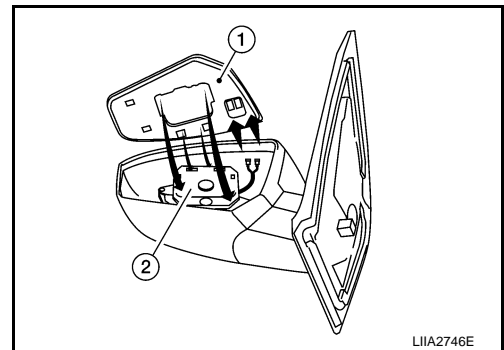

A
B
C
D
E
F
G
H
J
K
L
M
N
O
P

GW

INSIDE MIRROR

< SERVICE INFORMATION >

INSIDE MIRROR

Removal and Installation

INFOID:000000004409416

REMOVAL

Insert a suitable tool (A) to release the inside mirror (1). Slide the inside mirror (1) upward and remove the inside mirror from the base (2).

CAUTION:

- Do not use excessive force to remove the inside mirror because it is inserted tightly into the mirror base.
- Do not reuse the inside mirror removed from mirror base.

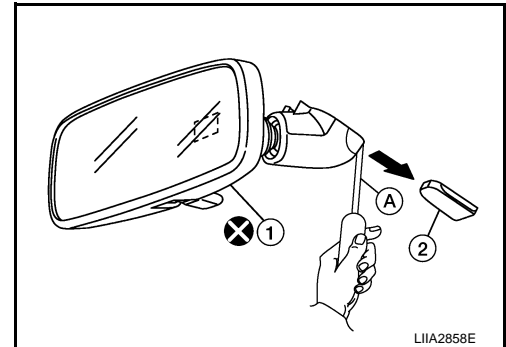

INSTALLATION

Installation is in the reverse order of removal.

CAUTION:

Be sure to insert the inside mirror to the mirror base until the pawl is engaged to the mirror base.