

# DI

## SECTION

# DRIVER INFORMATION SYSTEM

## CONTENTS

<b>SERVICE INFORMATION</b> .....	3	Wiring Diagram - 2METER - .....	24	A
<b>PRECAUTION</b> .....	3	Terminal and Reference Value for Double Meter .....	26	B
Precaution for Supplemental Restraint System (SRS) "AIR BAG" and "SEAT BELT PRE-TENSIONER" .....	3	Terminal and Reference Value for Combination Meter .....	26	C
Precaution Necessary for Steering Wheel Rotation After Battery Disconnect .....	3	CONSULT-III Function (METER/M&A) .....	26	D
<b>PREPARATION</b> .....	4	Trouble Diagnosis .....	26	E
Commercial Service Tool .....	4	Symptom Chart .....	27	F
<b>COMBINATION METERS</b> .....	5	Power Supply and Ground Circuit Inspection .....	27	G
Component Parts and Harness Connector Location .....	5	Oil Pressure Sensor Inspection .....	27	H
System Description .....	5	Removal and Installation .....	29	I
Arrangement of Combination Meter .....	8	<b>WARNING LAMPS</b> .....	31	J
Schematic .....	9	Schematic .....	31	DI
Wiring Diagram - METER - .....	10	Wiring Diagram - WARN - .....	32	L
Combination Meter Harness Connector Terminal Layout .....	12	Oil Pressure Warning Lamp Stays Off (Ignition Switch ON) .....	39	M
Terminal and Reference Value for Combination Meter .....	12	Oil Pressure Warning Lamp Does Not Turn Off (Oil Pressure Is Normal) .....	41	N
Self-Diagnosis Mode of Combination Meter .....	13	Component Inspection .....	42	O
CONSULT-III Function (METER/M&A) .....	14	<b>CVT INDICATOR</b> .....	43	P
Trouble Diagnosis .....	16	System Description .....	43	
Symptom Chart .....	16	Wiring Diagram - CVTIND - .....	44	
Power Supply and Ground Circuit Inspection .....	16	CVT Indicator Does Not Illuminate .....	46	
Vehicle Speed Signal Inspection .....	17	<b>WARNING CHIME</b> .....	48	
Engine Speed Signal Inspection .....	18	Component Parts and Harness Connector Location .....	48	
Water Temperature Signal Inspection .....	18	System Description .....	49	
Fuel Level Sensor Signal Inspection .....	19	Wiring Diagram - CHIME - .....	52	
Fuel Gauge Fluctuates, Indicates Wrong Value, or Varies .....	20	Terminal and Reference Value for BCM .....	53	
Fuel Gauge Does Not Move to Full-position .....	21	CONSULT-III Function (BCM) .....	53	
DTC [U1000] CAN Communication Circuit .....	21	Trouble Diagnosis .....	54	
Electrical Component Inspection .....	21	Combination Meter Buzzer Circuit Inspection .....	55	
Removal and Installation .....	22	Front Door Switch LH Signal Inspection .....	56	
<b>DOUBLE METERS</b> .....	23	Key Switch Signal Inspection (Without Intelligent Key) .....	57	
System Description .....	23	Key Switch and Ignition Knob Switch Signal Inspection (With Intelligent Key, When Mechanical Key Is Used) .....	58	
		Lighting Switch Signal Inspection .....	60	

---

Seat Belt Buckle Switch LH Signal Inspection .....	60	Electrical Component Inspection .....	62
Parking Brake Switch Signal Inspection .....	61		

# PRECAUTION

< SERVICE INFORMATION >

## SERVICE INFORMATION

### PRECAUTION

#### Precaution for Supplemental Restraint System (SRS) "AIR BAG" and "SEAT BELT PRE-TENSIONER"

INFOID:000000004779261

The Supplemental Restraint System such as "AIR BAG" and "SEAT BELT PRE-TENSIONER", used along with a front seat belt, helps to reduce the risk or severity of injury to the driver and front passenger for certain types of collision. This system includes seat belt switch inputs and dual stage front air bag modules. The SRS system uses the seat belt switches to determine the front air bag deployment, and may only deploy one front air bag, depending on the severity of a collision and whether the front occupants are belted or unbelted. Information necessary to service the system safely is included in the SRS and SB section of this Service Manual.

#### **WARNING:**

- To avoid rendering the SRS inoperative, which could increase the risk of personal injury or death in the event of a collision which would result in air bag inflation, all maintenance must be performed by an authorized NISSAN/INFINITI dealer.
- Improper maintenance, including incorrect removal and installation of the SRS can lead to personal injury caused by unintentional activation of the system. For removal of Spiral Cable and Air Bag Module, see the SRS section.
- Do not use electrical test equipment on any circuit related to the SRS unless instructed to in this Service Manual. SRS wiring harnesses can be identified by yellow and/or orange harnesses or harness connectors.
- When working near the Airbag Diagnosis Sensor Unit or other Airbag System sensors with the Ignition ON or engine running, DO NOT use air or electric power tools or strike near the sensor(s) with a hammer. Heavy vibration could activate the sensor(s) and deploy the air bag(s), possibly causing serious injury.
- When using air or electric power tools or hammers, always switch the Ignition OFF, disconnect the battery, and wait at least 3 minutes before performing any service.

#### Precaution Necessary for Steering Wheel Rotation After Battery Disconnect

INFOID:000000004750049

#### **NOTE:**

- This Procedure is applied only to models with Intelligent Key system and NATS (NISSAN ANTI-THEFT SYSTEM).
- Remove and install all control units after disconnecting both battery cables with the ignition knob in the "LOCK" position.
- Always use CONSULT-III to perform self-diagnosis as a part of each function inspection after finishing work. If DTC is detected, perform trouble diagnosis according to self-diagnostic results.

For models equipped with the Intelligent Key system and NATS, an electrically controlled steering lock mechanism is adopted on the key cylinder.

For this reason, if the battery is disconnected or if the battery is discharged, the steering wheel will lock and steering wheel rotation will become impossible.

If steering wheel rotation is required when battery power is interrupted, follow the procedure below before starting the repair operation.

#### OPERATION PROCEDURE

1. Connect both battery cables.

#### **NOTE:**

Supply power using jumper cables if battery is discharged.

2. Use the Intelligent Key or mechanical key to turn the ignition switch to the "ACC" position. At this time, the steering lock will be released.
3. Disconnect both battery cables. The steering lock will remain released and the steering wheel can be rotated.
4. Perform the necessary repair operation.
5. When the repair work is completed, return the ignition switch to the "LOCK" position before connecting the battery cables. (At this time, the steering lock mechanism will engage.)
6. Perform a self-diagnosis check of all control units using CONSULT-III.

# PREPARATION

< SERVICE INFORMATION >

## PREPARATION

### Commercial Service Tool

INFOID:000000004407611

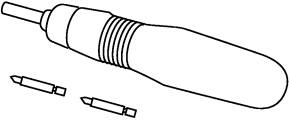
Tool name	Description
<p data-bbox="162 352 272 378">Power tool</p>  <p data-bbox="852 571 922 588">PBIC0191E</p>	<p data-bbox="1015 352 1263 378">Loosening bolts and nuts</p>

# COMBINATION METERS

< SERVICE INFORMATION >

## COMBINATION METERS

### Component Parts and Harness Connector Location

INFOID:000000004407612

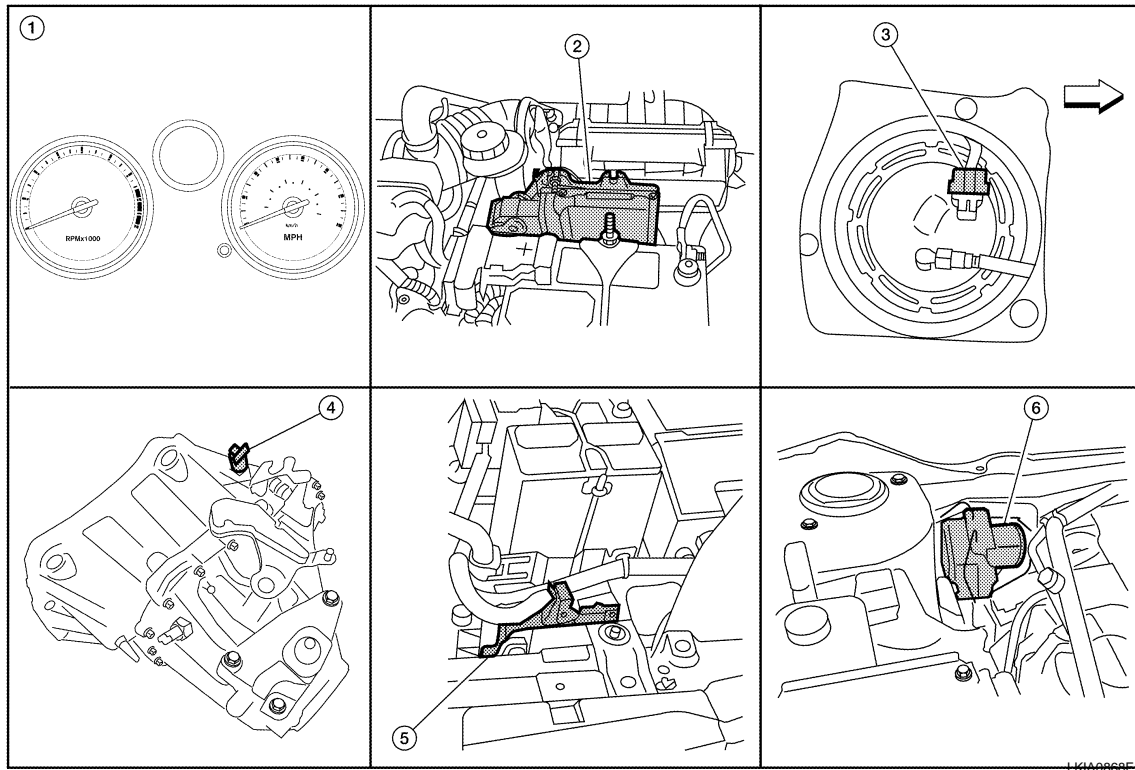

- |  |            |  |
|--|------------|--|
| 1. Combination meter M24                         | 2. ECM E16 | 3. Fuel level sensor unit and fuel pump (fuel level sensor) B48 (view with rear seat and inspection hole cover removed) (←: Front) |
| 4. Vehicle speed sensor F41 (without ABS or CVT) | 5. TCM F23 | 6. ABS actuator and electric unit (control unit) E33   |

### System Description

INFOID:000000004407613

#### UNIFIED METER CONTROL UNIT

- Speedometer, odo/trip meter, tachometer, water temperature gauge and fuel gauge are controlled by the unified meter control unit, which is built into the combination meter.
- Warning and indicator lamps are controlled by signals drawn from the CAN communication system, BCM (body control module), and components connected directly to the combination meter.
- Odo/trip meter and CVT indicator segments can be checked in self-diagnosis mode.
- Meters/gauges can be checked in self-diagnosis mode.

#### POWER SUPPLY AND GROUND CIRCUIT

Power is supplied at all times

- through 10A fuse [No. 19, located in the fuse block (J/B)]
- to combination meter terminal 1.

With the ignition switch in the ON or START position, power is supplied

- through 10A fuse [No. 14, located in the fuse block (J/B)]
- to combination meter terminal 2.

With the ignition switch in the ACC or ON position, power is supplied

- through 10A fuse [No. 6, located in the fuse block (J/B)]
- to combination meter terminal 23.

Ground is supplied

# COMBINATION METERS

## < SERVICE INFORMATION >

- to combination meter terminals 3, 21 and 22
- through grounds M57 and M61.

## SPEEDOMETER

With ABS

The ABS actuator and electric unit (control unit) provides a vehicle speed signal to the combination meter via CAN communication lines.

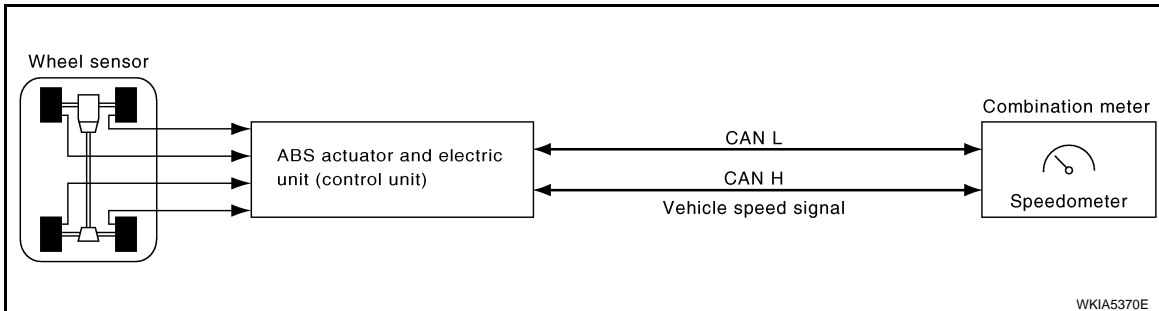

Without ABS or CVT

The vehicle speed sensor provides a vehicle speed signal to the combination meter for speedometer indication.

With CVT, Without ABS

The TCM provides a vehicle speed signal to the combination meter via CAN communication lines.

## TACHOMETER

The tachometer indicates engine speed in revolutions per minute (rpm). The ECM provides an engine speed signal to combination meter via CAN communication lines.

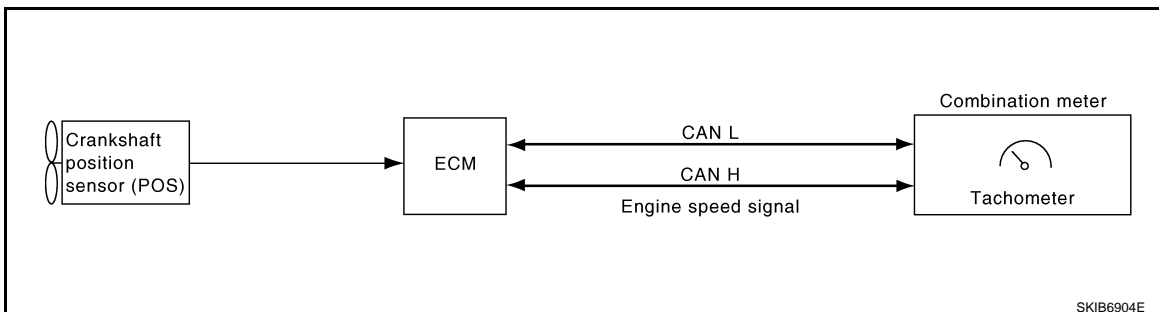

## FUEL GAUGE

The fuel gauge indicates the approximate fuel level in the fuel tank.

The fuel gauge is regulated by the unified meter control unit and a variable resistor signal supplied

- to combination meter terminal 4
- through fuel level sensor unit and fuel pump terminal 5
- through fuel level sensor unit and fuel pump terminal 2
- from combination meter terminal 8.

## WATER TEMPERATURE GAUGE

The water temperature gauge indicates the engine coolant temperature.

The ECM provides an engine coolant temperature signal to the combination meter via CAN communication lines.

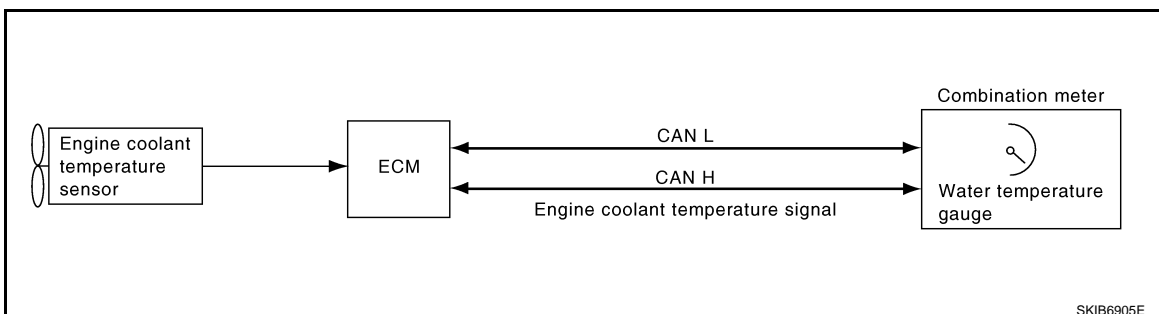

# COMBINATION METERS

## < SERVICE INFORMATION >

---

### ODO/TRIP METER

The vehicle speed signal and the memory signals from the meter memory circuit are processed by the combination meter and the mileage is displayed.

#### How to Change the Display

Refer to Owner's Manual for odo/trip meter operating instructions.

### CAN COMMUNICATION SYSTEM DESCRIPTION

Refer to [LAN-6. "System Description"](#).

A

B

C

D

E

F

G

H

I

J

**DI**

L

M

N

O

P

# COMBINATION METERS

< SERVICE INFORMATION >

## Arrangement of Combination Meter

INFOID:000000004407614

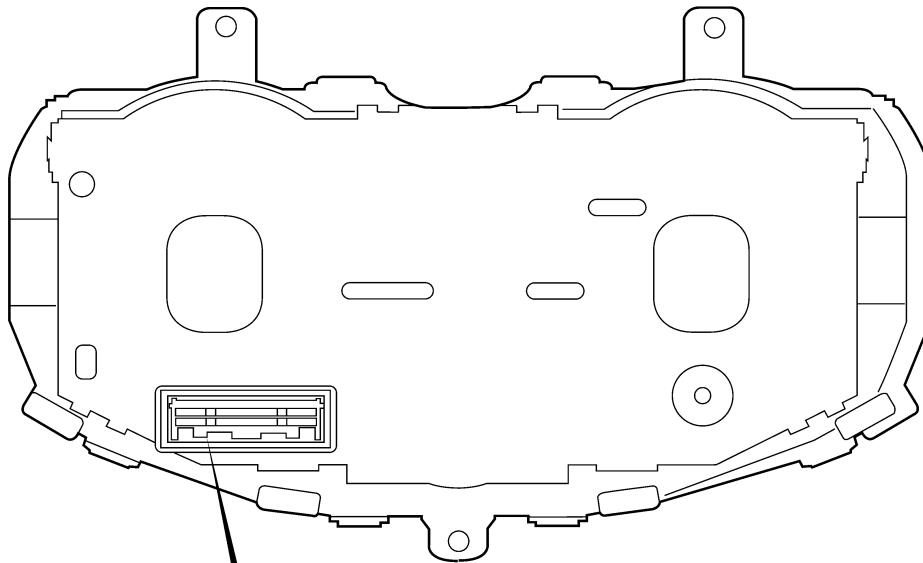
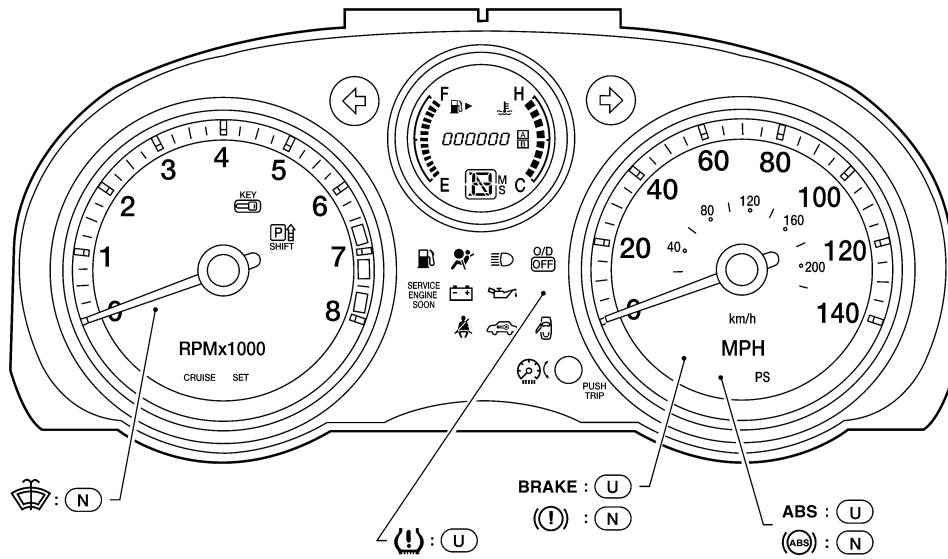

1	2	3	4	5	6	7	8	9	10	11	12	13	14	15	16	17	18	19	20	(M24)
21	22	23	24	25	26	27	28	29	30	31	32	33	34	35	36	37	38	39	40	

(N) : Canada

(U) : USA

WKIA5975E



# COMBINATION METERS

< SERVICE INFORMATION >

## Schematic

INFOID:000000004407615

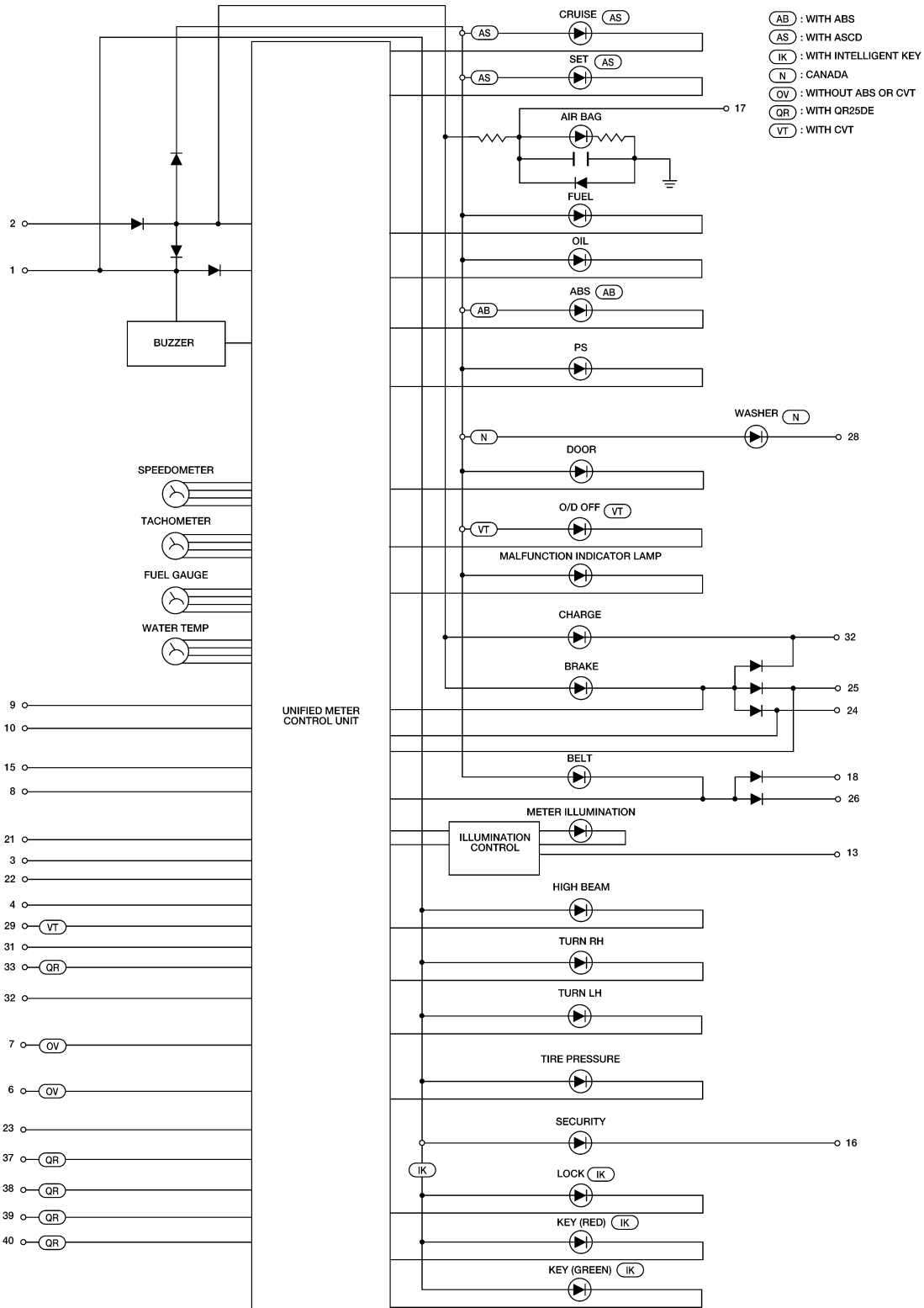

A  
B  
C  
D  
E  
F  
G  
H  
I  
J  
K  
L  
M  
N  
O  
P

DI

ABNWA0316GE

# COMBINATION METERS

< SERVICE INFORMATION >

## Wiring Diagram - METER -

INFOID:000000004407616

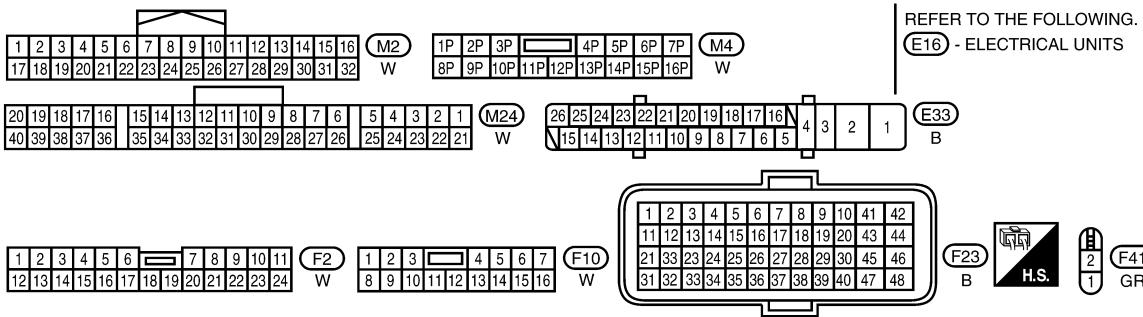
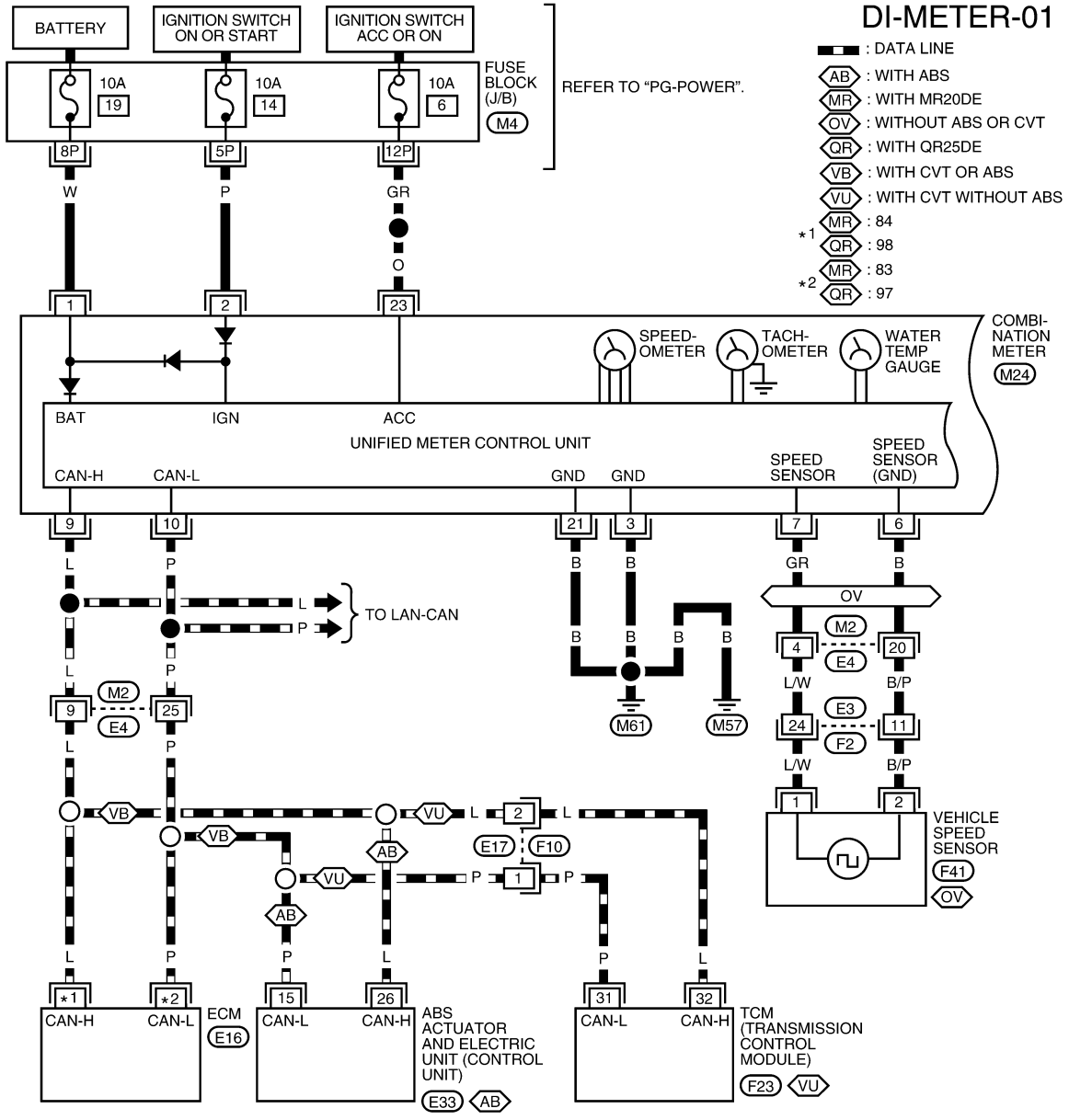

AWMWA0093G

# COMBINATION METERS

< SERVICE INFORMATION >

DI-METER-02

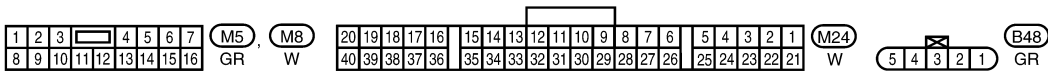
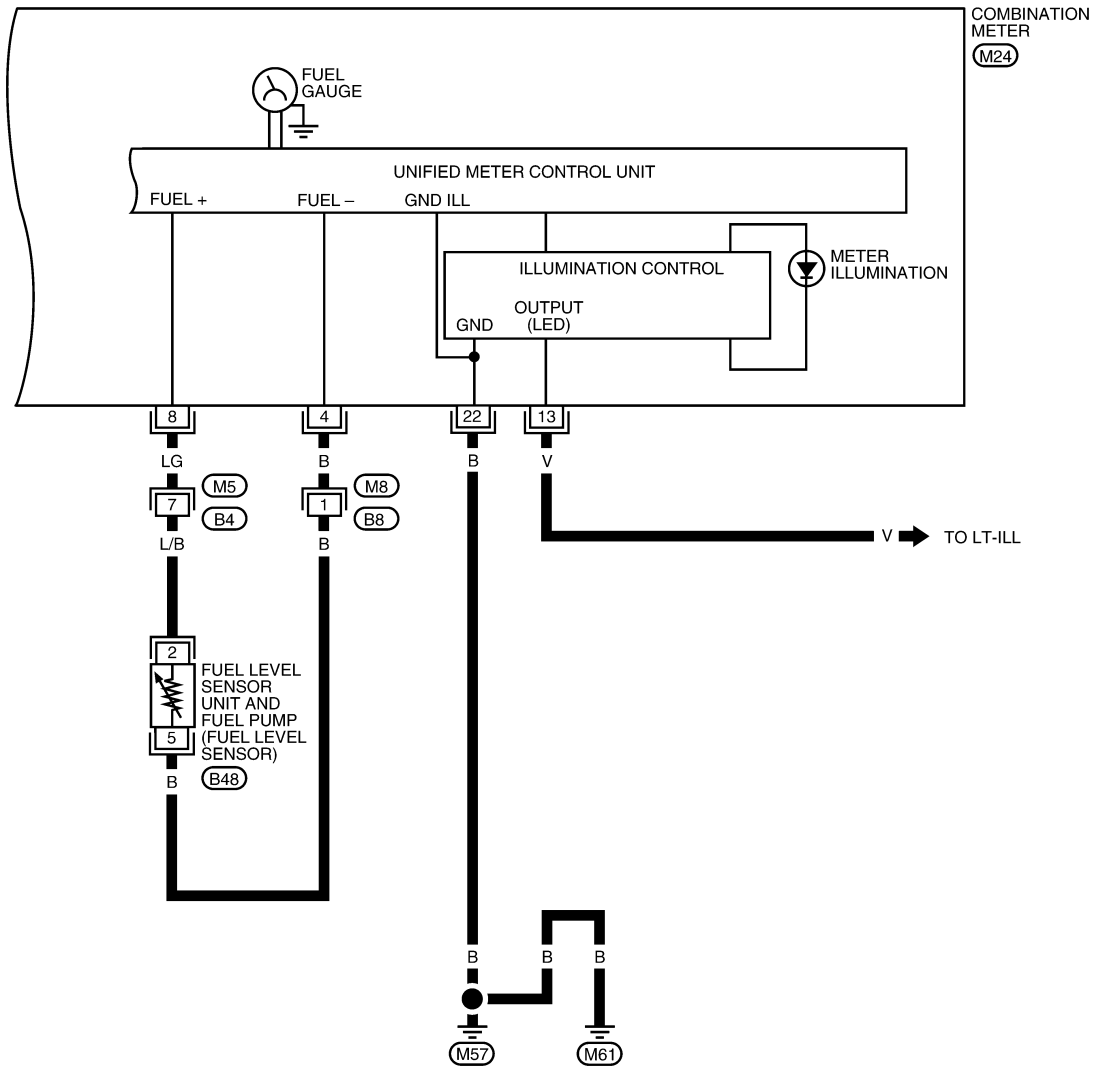

ABNWA0301GE

# COMBINATION METERS

< SERVICE INFORMATION >

## Combination Meter Harness Connector Terminal Layout

INFOID:000000004407617

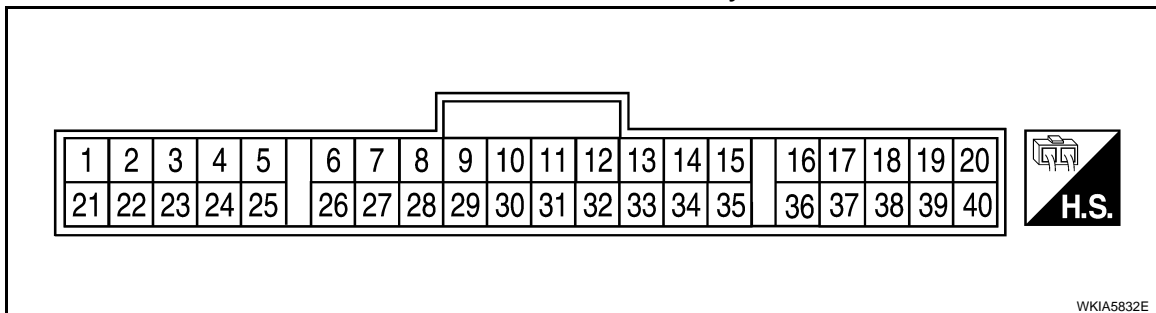

## Terminal and Reference Value for Combination Meter

INFOID:000000004407618

Terminal No.	Wire color	Item	Condition		Reference value (V) (Approx.)
			Ignition switch	Operation or condition	
1	W	Battery power supply	OFF	—	Battery voltage
2	P	Ignition switch ON or START	ON	—	Battery voltage
3	B	Ground (power)	—	—	0
4	B	Fuel level sensor ground (-)	ON	—	0
6	B	Vehicle speed sensor ground (without ABS or CVT)	ON	—	0
7	GR	Vehicle speed signal (without ABS or CVT)	ON	Speedometer operated [When vehicle speed is approx. 20 km/h (12 MPH)]	240 Hz
8	LG	Fuel level sensor signal (+)	—	—	Refer to <a href="#">DI-21, "Electrical Component Inspection"</a> .
9	L	CAN-H	—	—	—
10	P	CAN-L	—	—	—
13	V	Illumination control switch (LED)	—	—	Refer to <a href="#">LT-96, "System Description"</a> .
16	SB	Immobilizer/security indicator input	OFF	Security indicator ON	0
				Security indicator OFF	Battery voltage
18	G	Seat belt buckle switch RH	ON	Unfastened (ON)	0
				Fastened (OFF)	Battery voltage
21	B	Ground (illumination)	—	—	0
22					
23	O	Ignition switch ACC or ON	ON	—	Battery voltage
24	GR	Parking Brake switch	ON	Parking brake applied	0
				Parking brake released	Battery voltage
25	V	Brake fluid level switch	ON	Brake fluid level low	0
				Brake fluid level normal	Battery voltage
26	O	Seat belt buckle switch LH	ON	Unfastened (ON)	0
				Fastened (OFF)	Battery voltage
28	R	Washer fluid level switch (Canada models)	ON	Washer fluid level low	0
				Washer fluid level normal	Battery voltage
29	W	O/D OFF switch	ON	O/D OFF switch pressed	0
				O/D OFF switch released	Battery voltage

# COMBINATION METERS

## < SERVICE INFORMATION >

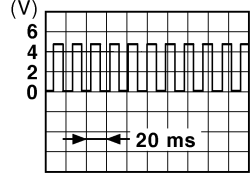
Ter- mi- nal No.	Wire color	Item	Condition		Reference value (V) (Approx.)
			Ignition switch	Operation or condition	
31	O	Vehicle speed signal output (8-pulse)	ON	Speedometer operated [When vehicle speed is approx. 40 km/h (25 MPH)]	<b>NOTE:</b> Maximum voltage may be 12 V due to specifications (connected units).  PKIC0643E
32	BR	Generator	ON	Generator voltage low	0
				Generator voltage normal	Battery voltage
33	V	Illumination output to double meter	—	—	Refer to <a href="#">LT-96, "System Description"</a> .
37*	LG	Manual mode signal	ON	Manual mode switch ON	0
				Manual mode switch OFF	Battery voltage
38*	SB	Not manual mode signal	ON	Manual mode switch ON	0
				Manual mode switch OFF	Battery voltage
39*	W	A/T steering shift up signal	ON	<ul style="list-style-type: none"> <li>Manual mode switch ON</li> <li>Steering shift up operation</li> </ul>	0
				Other than above	Battery voltage
40*	Y	A/T steering shift down signal	ON	<ul style="list-style-type: none"> <li>Manual mode switch ON</li> <li>Steering shift down operation</li> </ul>	0
				Other than above	Battery voltage

\*: With QR25DE

## Self-Diagnosis Mode of Combination Meter

INFOID:000000004407619

### SELF-DIAGNOSIS MODE FUNCTION

- Self-diagnosis can check for continuity between the meter control circuit and the speedometer and tachometer.
- Self-diagnosis can check for odo/trip meter and CVT indicator segments.

### OPERATION PROCEDURE

1. Turn the ignition switch ON, and switch the odo/trip meter to "trip A" or "trip B".

**NOTE:**

If the diagnosis function is activated with "trip A" displayed, the mileage on "trip A" will indicate "0000.0", but the actual trip mileage will be retained. (The same applies for "trip B".)

2. Turn ignition switch OFF.
3. While pushing the odo/trip meter switch (1), turn the ignition switch ON.
4. Confirm that the trip meter displays "0000.0".
5. Push the odo/trip meter switch at least 3 times. (Within 7 seconds after the ignition switch is turned ON.)

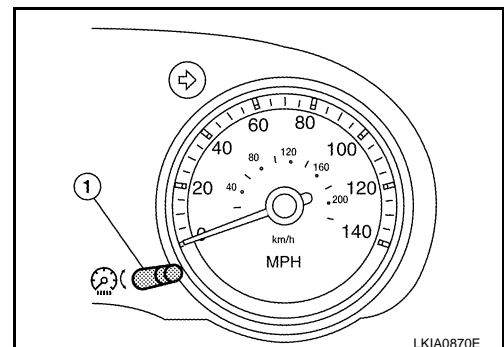

# COMBINATION METERS

## < SERVICE INFORMATION >

6. All segments on the odo/trip meter illuminate. At this time, the unified meter control unit is turned to self-diagnosis mode.

**NOTE:**

- Check combination meter power supply and ground circuit when self-diagnosis mode of combination meter does not start. Replace combination meter if normal. Refer to [IP-12, "Removal and Installation"](#).
- If any of the segments is not displayed, replace combination meter. Refer to [IP-12, "Removal and Installation"](#).

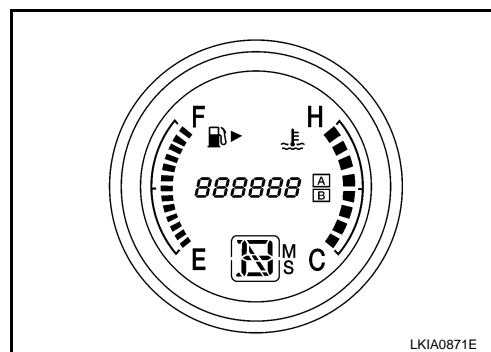

LKIA0871E

7. Each meter activates while pressing odo/trip meter switch.

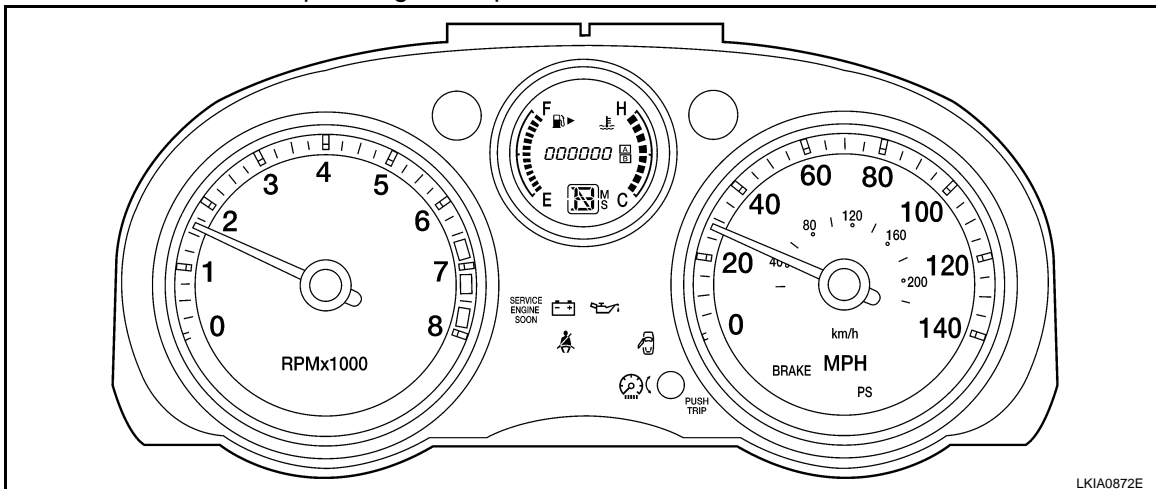

LKIA0872E

**NOTE:**

If the speedometer or tachometer are not activated, replace combination meter. Refer to [IP-12, "Removal and Installation"](#).

## CONSULT-III Function (METER/M&A)

INFOID:000000004407620

CONSULT-III can display each diagnostic item using the diagnostic test modes shown following.

METER diagnosis mode	Description
SELF-DIAG RESULTS	Displays combination meter self-diagnosis results.
DATA MONITOR	Displays combination meter input/output data in real time.
CAN DIAG SUPPORT MNTR	The result of transmit/receive diagnosis of CAN communication can be read.

## SELF-DIAGNOSTIC RESULTS

### Display Item List

CONSULT-III display	Malfunction	Reference page
CAN COMM CIRC [U1000]	Malfunction is detected in CAN communication lines. <b>CAUTION:</b> Even when there is no malfunction on CAN communication system, malfunction may be misinterpreted when battery has low voltage (when maintaining 7 - 8 V for about 2 seconds) or 10A fuse [No. 14, located in the fuse block (J/B)] is removed.	<a href="#">DI-21</a>
VEHICLE SPEED CIRC [B2205]	Malfunction is detected when an erroneous speed signal is input. <b>CAUTION:</b> Even when there is no malfunction on speed signal system, malfunctions may be misinterpreted when battery has low voltage (when maintaining 7 - 8 V for about 2 seconds).	<a href="#">DI-17</a>

**NOTE:**

“TIME” indicates the following.

## COMBINATION METERS

### < SERVICE INFORMATION >

- 0: Indicates that a malfunction is detected at present.
- 1-63: Indicates that a malfunction was detected in the past. (Displays number of ignition switch OFF → ON cycles after malfunction is detected. Self-diagnostic result is erased when “63” is exceeded.)

### DATA MONITOR

#### Display Item List

Display item [Unit]	MAIN SIGNALS	SELECTION FROM MENU	Contents
SPEED METER [km/h]	X	X	The value of vehicle speed signal, which is input from ABS actuator and electric unit (control unit).
SPEED OUTPUT [km/h]	X	X	The value of vehicle speed signal, which is transmitted to each unit with CAN communication.
TACHO METER [rpm]	X	X	The value of engine speed signal, which is input from ECM.
W TEMP METER [°C]	X	X	The value of engine coolant temperature signal, which is input from ECM.
FUEL METER [lit.]	X	X	The value, which processes a resistance signal from fuel gauge.
FUEL W/L [ON/OFF]	X	X	Indicates [ON/OFF] condition of low-fuel warning lamp.
C-ENG W/L [ON/OFF]		X	Indicates [ON/OFF] condition of malfunction indicator lamp (MIL).
AIR PRES W/L		X	Indicates [ON/OFF] condition of low tire pressure warning lamp.
SEAT BELT W/L		X	Indicates [ON/OFF] condition of seat belt warning lamp.
BUZZER [ON/OFF]	X	X	Indicates [ON/OFF] condition of buzzer.
DOOR W/L [ON/OFF]		X	Indicates [ON/OFF] condition of door warning lamp.
HI-BEAM IND [ON/OFF]		X	Indicates [ON/OFF] condition of high beam indicator lamp.
TURN IND [ON/OFF]		X	Indicates [ON/OFF] condition of turn indicator.
OIL W/L [ON/OFF]		X	Indicates [ON/OFF] condition of oil pressure warning lamp.
ABS W/L [ON/OFF]		X	Indicates [ON/OFF] condition of ABS warning lamp.
BRAKE W/L [ON/OFF]		X	Indicates [ON/OFF] condition of brake warning lamp.*
KEY G/Y W/L [ON/OFF]		X	Indicates [ON/OFF] condition of KEY warning lamp (green).
KEY R W/L [ON/OFF]		X	Indicates [ON/OFF] condition of KEY warning lamp (red).
KEY KNOB W/L [ON/OFF]		X	Indicates [ON/OFF] condition of LOCK warning lamp.
O/D OFF SW [ON/OFF]		X	Indicates [ON/OFF] condition of O/D OFF switch.
P RANGE IND [ON/OFF]	X	X	Indicates [ON/OFF] condition of CVT shift P range indicator.
R RANGE IND [ON/OFF]	X	X	Indicates [ON/OFF] condition of CVT shift R range indicator.
N RANGE IND [ON/OFF]	X	X	Indicates [ON/OFF] condition of CVT shift N range indicator.
D RANGE IND [ON/OFF]	X	X	Indicates [ON/OFF] condition of CVT shift D range indicator.
L RANGE IND [ON/OFF]	X	X	Indicates [ON/OFF] condition of CVT shift L range indicator.
M RANGE SW [ON/OFF]	X	X	Indicates [ON/OFF] condition of manual mode range switch.
NM RANGE SW [ON/OFF]	X	X	Indicates [ON/OFF] condition of except manual mode range switch.
AT-M IND [ON/OFF]	X	X	Indicates [ON/OFF] condition of manual mode indicator.
AT-M GEAR [1 - 8]	X	X	Indicates [1 - 8] condition of manual mode gear position.
SPORT IND [ON/OFF]		X	Indicates [ON/OFF] condition of O/D OFF indicator.
ST SFT UP SW [ON/OFF]		X	Indicates [ON/OFF] condition of steering shift up switch.
ST SFT DWN SW [ON/OFF]		X	Indicates [ON/OFF] condition of steering shift down switch.
CRUISE IND [ON/OFF]		X	Indicates [ON/OFF] condition of CRUISE indicator.

# COMBINATION METERS

## < SERVICE INFORMATION >

Display item [Unit]	MAIN SIGNALS	SELECTION FROM MENU	Contents
SET IND [ON/OFF]		X	Indicates [ON/OFF] condition of SET indicator.
EPS W/L [ON/OFF]		X	Indicates [ON/OFF] condition of EPS warning lamp.

\*: The monitor will indicate "OFF" even though the brake warning lamp is on if either of the following conditions exist.

- The parking brake is engaged
- The brake fluid level is low

## Trouble Diagnosis

INFOID:000000004407621

### HOW TO PERFORM TROUBLE DIAGNOSIS

1. Confirm the symptom or customer complaint.
2. Perform preliminary check. Refer to "PRELIMINARY CHECK".
3. According to the symptom chart, repair or replace the cause of the malfunction. Refer to [DI-16, "Symptom Chart"](#).
4. Does the meter operate normally? If so, GO TO 5. If not, GO TO 2.
5. Inspection End.

### PRELIMINARY CHECK

#### 1. CHECK SELF-DIAGNOSIS OPERATION OF COMBINATION METER

Perform self-diagnosis of combination meter. Refer to [DI-13, "Self-Diagnosis Mode of Combination Meter"](#).

Does self-diagnosis mode operate?

YES >> GO TO 2.

NO >> Check power supply and ground circuit of combination meter. Refer to [DI-16, "Power Supply and Ground Circuit Inspection"](#).

#### 2. CHECK COMBINATION METER (CONSULT-III)

Select "METER/M&A" on CONSULT-III and perform self-diagnosis of combination meter. Refer to [DI-14, "CONSULT-III Function \(METER/M&A\)"](#).

Self-diagnostic results content

No malfunction detected>> Refer to [DI-16, "Symptom Chart"](#).

Malfunction detected>> Refer to [DI-14, "CONSULT-III Function \(METER/M&A\)"](#).

## Symptom Chart

INFOID:000000004407622

Symptom	Possible cause
Improper speedometer and odo/trip meter indication.	Refer to <a href="#">DI-17, "Vehicle Speed Signal Inspection"</a> .
Improper tachometer indication.	Refer to <a href="#">DI-18, "Engine Speed Signal Inspection"</a> .
Improper fuel gauge indication.	Refer to <a href="#">DI-19, "Fuel Level Sensor Signal Inspection"</a> .
Low-fuel warning lamp indication is irregular.	
Improper water temperature gauge indication.	Refer to <a href="#">DI-18, "Water Temperature Signal Inspection"</a> .
Improper CVT position indication.	Refer to <a href="#">DI-46, "CVT Indicator Does Not Illuminate"</a> .

## Power Supply and Ground Circuit Inspection

INFOID:000000004407623

#### 1. CHECK FUSE

Check for blown combination meter fuses.

Power source	Fuse No.
Battery	19
Ignition switch ON or START	14
Ignition switch ACC or ON	6



# COMBINATION METERS

## < SERVICE INFORMATION >

### OK or NG

OK >> GO TO 2.

NG >> Be sure to eliminate cause of malfunction before installing new fuse. Refer to [PG-3](#).

## 2.CHECK POWER SUPPLY CIRCUIT

Check voltage between combination meter harness connector terminals and ground.

Terminals		Ignition switch position			
(+)		(-)	OFF	ACC	ON
Combination meter connector	Terminal				
M24	1	Ground	Battery voltage	Battery voltage	Battery voltage
	2		0V	0V	Battery voltage
	23		0V	Battery voltage	Battery voltage

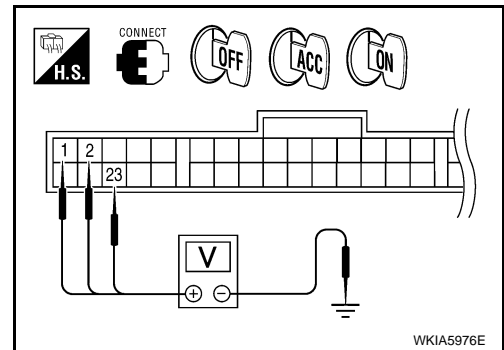

### OK or NG

OK >> GO TO 3.

NG >> Repair harness or connector.

## 3.CHECK GROUND CIRCUIT

1. Turn ignition switch OFF.
2. Disconnect combination meter connector.
3. Check continuity between combination meter harness connector terminals and ground.

Combination meter connector	Terminal	Ground	Continuity
M24	3		Yes
	21		
	22		

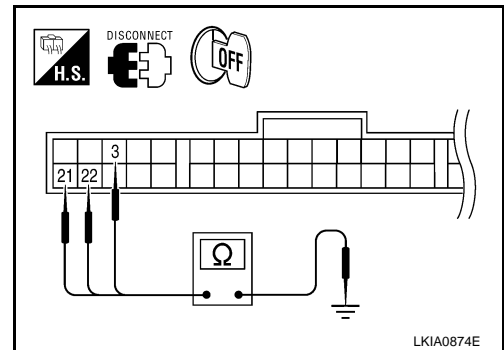

### OK or NG

OK >> Replace combination meter. Refer to [IP-12, "Removal and Installation"](#).

NG >> Repair harness or connector.

## Vehicle Speed Signal Inspection

INFOID:000000004407624

Symptom:

- Improper speedometer and odo/trip meter indication.
- Display VEHICLE SPEED CIRC [B2205] at the result of self-diagnosis for combination meter.

WITH ABS

## 1.CHECK COMBINATION METER INPUT SIGNAL

1. Start engine and select "METER/M&A" on CONSULT-III.
2. Using "SPEED METER" on "DATA MONITOR", compare the value of "DATA MONITOR" with speedometer pointer of combination meter.

### OK or NG

OK >> Perform ABS actuator and electric unit (control unit) self-diagnosis. Refer to [BRC-18, "CONSULT-III Function \(ABS\)"](#).

NG >> Replace combination meter. Refer to [IP-12, "Removal and Installation"](#).

WITHOUT ABS OR CVT

## 1.CHECK VEHICLE SPEED SENSOR CIRCUITS

# COMBINATION METERS

## < SERVICE INFORMATION >

1. Remove vehicle speed sensor.
2. Turn ignition switch ON.
3. Rotate vehicle speed sensor while checking voltage between combination meter harness connector M24 terminals 6 and 7.

Terminals				Voltage (Approx.)
(+)		(-)		
Connector	Terminal	Connector	Terminal	
M24	7	M24	6	0.5

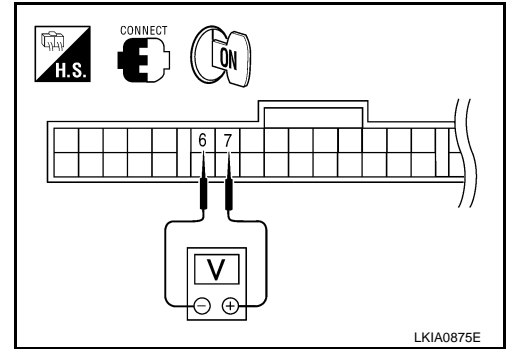

### OK or NG

- OK >> Replace combination meter. Refer to [IP-12, "Removal and Installation"](#).  
 NG >> GO TO 2.

## 2.CHECK VEHICLE SPEED SENSOR

1. Turn ignition switch OFF.
2. Disconnect vehicle speed sensor connector.
3. Check resistance between vehicle speed sensor terminals 1 and 2.

Terminals				Resistance value (Approx.)
(+)		(-)		
Component	Terminal	Component	Terminal	
Vehicle speed sensor	1	Vehicle speed sensor	2	250Ω

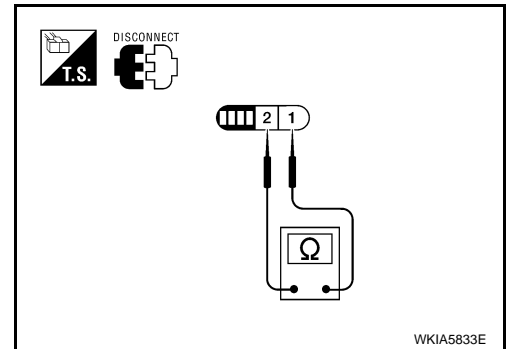

### OK or NG

- OK >> Check harness or connector between combination meter and vehicle speed sensor.  
 NG >> Replace vehicle speed sensor.

## WITH CVT, WITHOUT ABS

### 1.CHECK COMBINATION METER INPUT SIGNAL

1. Start engine and select "METER/M&A" on CONSULT-III.
2. Using "SPEED METER" on "DATA MONITOR", compare the value of "DATA MONITOR" with speedometer pointer of combination meter.

### OK or NG

- OK >> Perform TCM self-diagnosis. Refer to [CVT-47, "CONSULT-III Function \(TRANSMISSION\)"](#).  
 NG >> Replace combination meter. Refer to [IP-12, "Removal and Installation"](#).

## Engine Speed Signal Inspection

INFOID:000000004407625

Symptom: Improper tachometer indication.

### 1.CHECK COMBINATION METER INPUT SIGNAL

1. Start engine and select "METER/M&A" on CONSULT-III.
2. Using "TACHO METER" on "DATA MONITOR", compare the value of "DATA MONITOR" with tachometer pointer of combination meter.

### OK or NG

- OK >> Perform ECM self-diagnosis. Refer to [EC-123, "CONSULT-III Function \(ENGINE\)"](#).  
 NG >> Replace combination meter. Refer to [IP-12, "Removal and Installation"](#).

## Water Temperature Signal Inspection

INFOID:000000004407626

Symptom: Improper water temperature gauge indication.

### 1.CHECK COMBINATION METER INPUT SIGNAL

1. Start engine and select "METER/M&A" on CONSULT-III.

# COMBINATION METERS

## < SERVICE INFORMATION >

2. Run the engine at different temperatures and compare water temperature with "W TEMP METER" of "DATA MONITOR". Indication should be as follows:

**High: 130°C (266°F)**  
**Normal: 70 - 105°C (158 - 221°F)**  
**Cold: Less than 50°C (122°F)**

### OK or NG

- OK >> Perform ECM self-diagnosis. Refer to [EC-123. "CONSULT-III Function \(ENGINE\)".](#)  
NG >> Replace combination meter. Refer to [IP-12. "Removal and Installation".](#)

## Fuel Level Sensor Signal Inspection

INFOID:000000004407627

### Symptom:

- Improper fuel gauge indication.
- Low-fuel warning lamp indication is irregular.

### NOTE:

The following symptoms do not indicate a malfunction.

- Depending on vehicle position or driving circumstance, the fuel level in the tank shifts and the indication may fluctuate.
- If the vehicle is fueled with the ignition switch ON, the indication will update slowly.
- If the vehicle is tilted when the ignition switch is turned ON, fuel in the tank may flow to one direction resulting in a change of reading.

## 1. CHECK COMBINATION METER INPUT SIGNAL

1. Select "METER/M&A" on CONSULT-III.
2. Using "FUEL METER" on "DATA MONITOR", compare the value of "DATA MONITOR" with fuel gauge indication of combination meter.

Fuel gauge indication (approx. segments)	Reference value of data monitor [lit.]
Full (13)	Approx. 55
3/4 (10)	Approx. 38
1/2 (7)	Approx. 25
1/4 (4)	Approx. 13
Empty (0)	Approx. 4

### OK or NG

- OK >> GO TO 2.  
NG >> Replace combination meter. Refer to [IP-12. "Removal and Installation".](#)

## 2. CHECK HARNESS CONNECTOR

1. Turn ignition switch OFF.
2. Check combination meter and fuel level sensor unit terminals (meter-side and harness-side) for poor connection.

### OK or NG

- OK >> GO TO 3.  
NG >> Repair or replace terminals or connectors.

## 3. CHECK FUEL LEVEL SENSOR UNIT CIRCUIT

# COMBINATION METERS

## < SERVICE INFORMATION >

1. Disconnect combination meter connector and fuel level sensor unit connector.
2. Check continuity between combination meter harness connector (A) and fuel level sensor unit and fuel pump harness connector (B).

A		B		Continuity
Connector	Terminal	Connector	Terminal	
M24	8	B48	2	Yes

3. Check continuity between combination meter harness connector (A) and ground.

A		Ground	Continuity
Connector	Terminal		
M24	8		No

### OK or NG

- OK >> GO TO 4.  
 NG >> Repair harness or connector.

## 4. CHECK FUEL LEVEL SENSOR UNIT GROUND CIRCUIT

1. Check continuity between combination meter harness connector (A) and fuel level sensor unit and fuel pump harness connector (B).

A		B		Continuity
Connector	Terminal	Connector	Terminal	
M24	4	B48	5	Yes

2. Check continuity between combination meter harness connector (A) and ground.

A		Ground	Continuity
Connector	Terminal		
M24	4		No

### OK or NG

- OK >> GO TO 5.  
 NG >> Repair harness or connector.

## 5. CHECK FUEL LEVEL SENSOR UNIT

Check fuel level sensor unit. Refer to [DI-21. "Electrical Component Inspection"](#).

### OK or NG

- OK >> Check fuel level sensor unit installation, and check whether the float arm interferes or binds with any of the internal components in the fuel tank. Repair or replace malfunctioning part, if necessary.  
 NG >> Replace fuel level sensor unit.

## Fuel Gauge Fluctuates, Indicates Wrong Value, or Varies

INFOID:000000004407628

### 1. CHECK FUEL GAUGE FLUCTUATION

Test drive vehicle to see if gauge fluctuates only during driving or at the instant of stopping.

Does the indication value vary only during driving or at the at the instant of stopping?

- YES >> The gauge fluctuation may be caused by fuel level change in the fuel tank. Condition is normal.  
 NO >> Ask the customer about the situation when the symptom occurs in detail, and perform the trouble diagnosis.

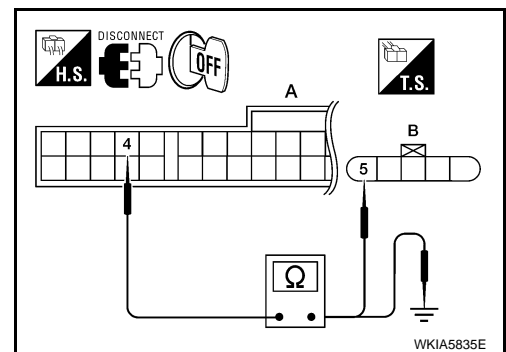
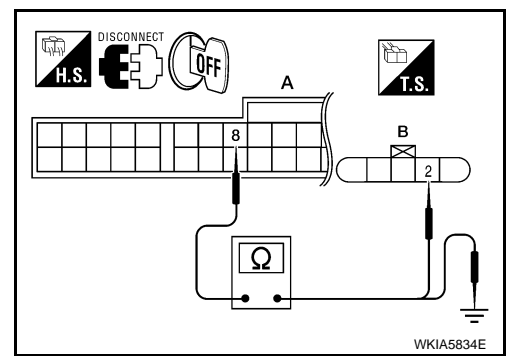

# COMBINATION METERS

< SERVICE INFORMATION >

## Fuel Gauge Does Not Move to Full-position

INFOID:000000004407629

### 1.OBSERVE FUEL GAUGE

Does it take a long time for the indication to move to FULL position?

YES or NO

- YES >> GO TO 2.
- NO >> GO TO 3.

### 2.IDENTIFY FUELING CONDITION

Was the vehicle fueled with the ignition switch ON?

YES or NO

- YES >> Be sure to fuel the vehicle with the ignition switch OFF. Otherwise, it will take a long time to move to FULL position because of the characteristic of the fuel gauge.
- NO >> GO TO 3.

### 3.OBSERVE VEHICLE POSITION

Is the vehicle parked on an incline?

YES or NO

- YES >> Check the fuel level indication with vehicle on a level surface.
- NO >> GO TO 4.

### 4.OBSERVE FUEL GAUGE POINTER

During driving, does the fuel gauge indication move gradually toward EMPTY position?

YES or NO

- YES >> Check the components. Refer to [DI-21. "Electrical Component Inspection"](#).
- NO >> The float arm may interfere or bind with any of the components in the fuel tank.

## DTC [U1000] CAN Communication Circuit

INFOID:000000004407630

Symptom: Display CAN COMM CIRC [U1000] at the result of self-diagnosis for combination meter.

### 1.CHECK CAN COMMUNICATION

Select "SELF-DIAG RESULTS" mode for "METER/M&A" with CONSULT-III.

>> Go to "CAN SYSTEM". Refer to [LAN-44. "Diagnosis Procedure"](#).

## Electrical Component Inspection

INFOID:000000004407631

### FUEL LEVEL SENSOR UNIT CHECK

For removal, refer to [FL-5. "Removal and Installation"](#).

Check Fuel Level Sensor Unit and Fuel Pump  
Check resistance between terminals 2 and 5.

Terminals		Float position mm (in)			Resistance value (Ω) (Approx.)
2	5	1*	Full	145.9 (5.74)	
		2*	Empty	14 (0.55)	81.5

1\* and 2\*: When float rod is in contact with stopper.

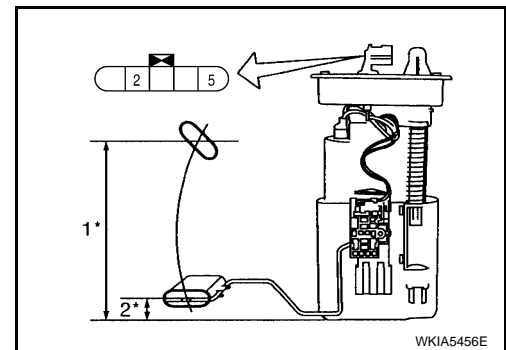

Check Fuel Level Sensor Unit and Fuel Pump Harness

# COMBINATION METERS

## < SERVICE INFORMATION >

Check continuity at the following terminals.

Terminal	Continuity
2 - Signal terminal (A)	Yes
5 - Ground terminal (B)	

- If the results of check are NG, replace fuel pump assembly. If the results of check are OK, replace fuel level sensor unit.

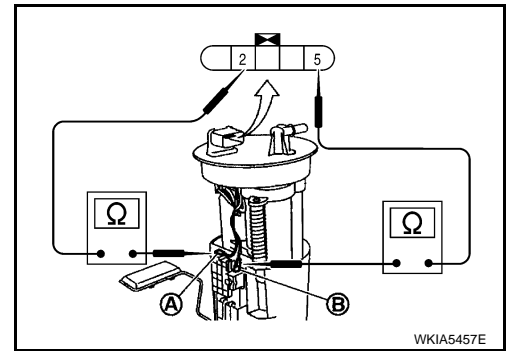

## Removal and Installation

### COMBINATION METER

Refer to [IP-12. "Removal and Installation"](#).

INFOID:000000004407632

# DOUBLE METERS

< SERVICE INFORMATION >

## DOUBLE METERS

### System Description

INFOID:000000004407633

#### DOUBLE METER

Oil pressure gauge and G-force gauge are controlled by the double meter.

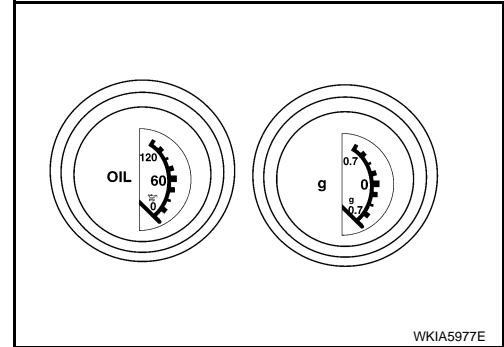

#### Oil Pressure Warning Lamp

The oil pressure warning lamp is controlled by the double meter. When the oil pressure is less than 4.52 psi (0.318 kg/cm<sup>2</sup>), the double meter sends a ground signal to the IPDM E/R. The IPDM E/R then sends a signal to the combination meter via CAN communication and the oil pressure warning lamp is turned on. When the oil pressure is greater than 6.5 psi (0.457 kg/cm<sup>2</sup>) the warning lamp turns off.

#### POWER SUPPLY AND GROUND CIRCUIT

Power is supplied at all times

- through 10A fuse [No. 19, located in the fuse block (J/B)]
- to double meter terminal 7 and
- to combination meter terminal 1.

With the ignition switch in the ON or START position, power is supplied

- through 10A fuse [No. 14, located in the fuse block (J/B)]
- to double meter terminal 8 and
- to combination meter terminal 2.

With the ignition switch in the ACC or ON position, power is supplied

- through 10A fuse [No. 6, located in the fuse block (J/B)]
- to combination meter terminal 23.

Ground is supplied

- to double meter terminals 9 and 10 and
- to combination meter terminals 3 and 21
- through body grounds M57 and M61.

#### OIL PRESSURE GAUGE

The oil pressure gauge indicates engine oil pressure.

With the ignition switch in the ON or START position, power is supplied

- through double meter terminal 3
- to oil pressure sensor terminal 3.

Ground is supplied

- through double meter terminal 5
- to oil pressure sensor terminal 1.

Double meter receives oil pressure signal from oil pressure sensor

- through oil pressure sensor terminal 2
- to double meter terminal 4.

#### G-FORCE GAUGE

The G-force gauge indicates the longitudinal acceleration and deceleration G-forces while driving. The indication is based on a calculation using the speed input supplied by the combination meter via CAN communication. The gauge does not indicate cornering G-forces.

# DOUBLE METERS

< SERVICE INFORMATION >

## Wiring Diagram - 2METER -

INFOID:000000004407634

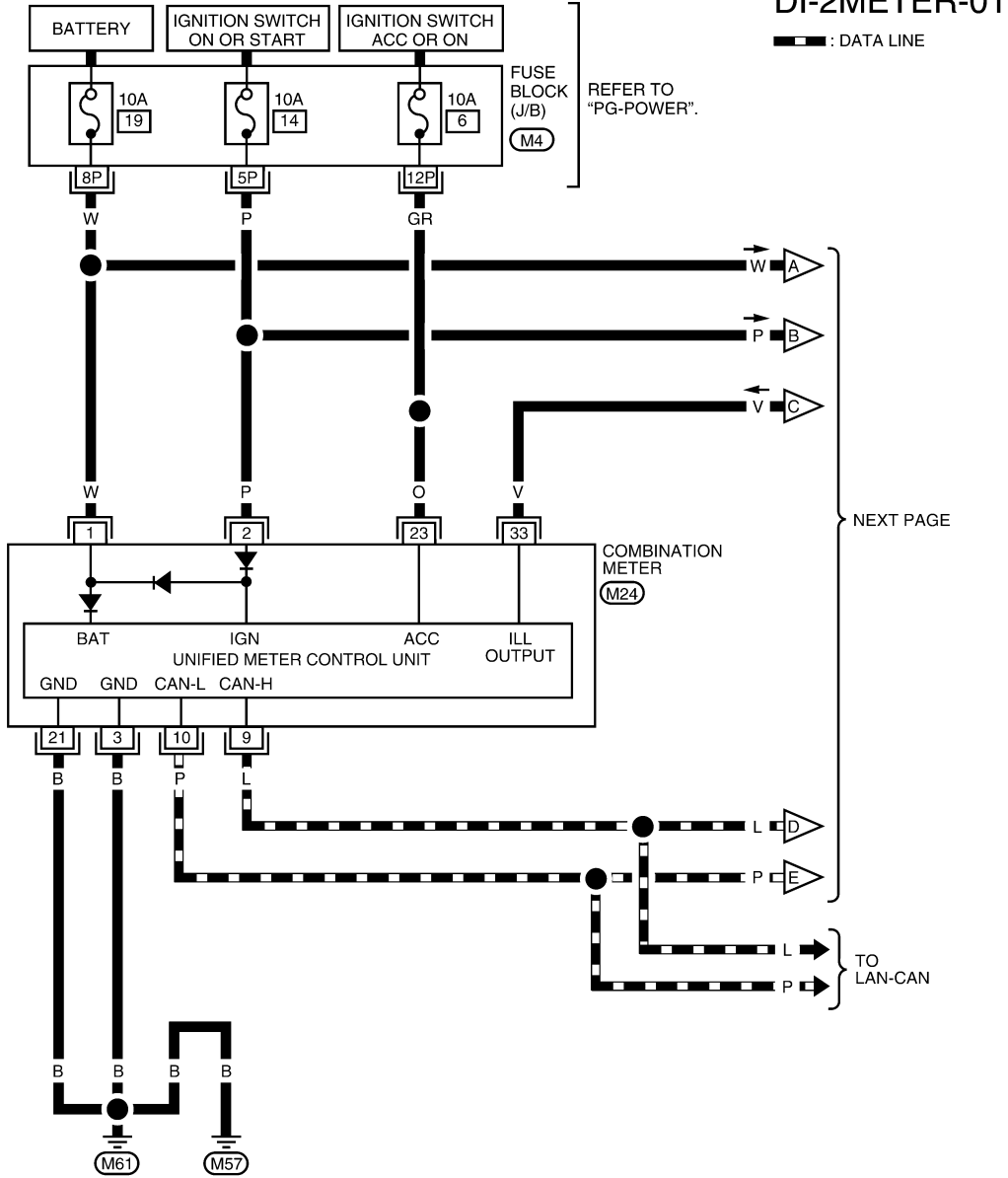

NEXT PAGE

1P	2P	3P	4P	5P	6P	7P	M4	20	19	18	17	16	15	14	13	12	11	10	9	8	7	6	5	4	3	2	1	M24
8P	9P	10P	11P	12P	13P	14P	W	40	39	38	37	36	35	34	33	32	31	30	29	28	27	26	25	24	32	22	21	W

AWMWA0094G



# DOUBLE METERS

< SERVICE INFORMATION >

## DI-2METER-02

— : DATA LINE

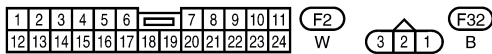
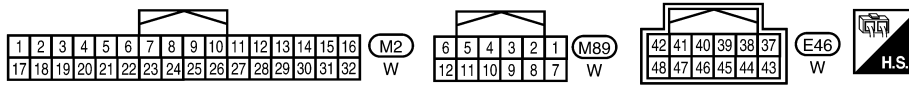
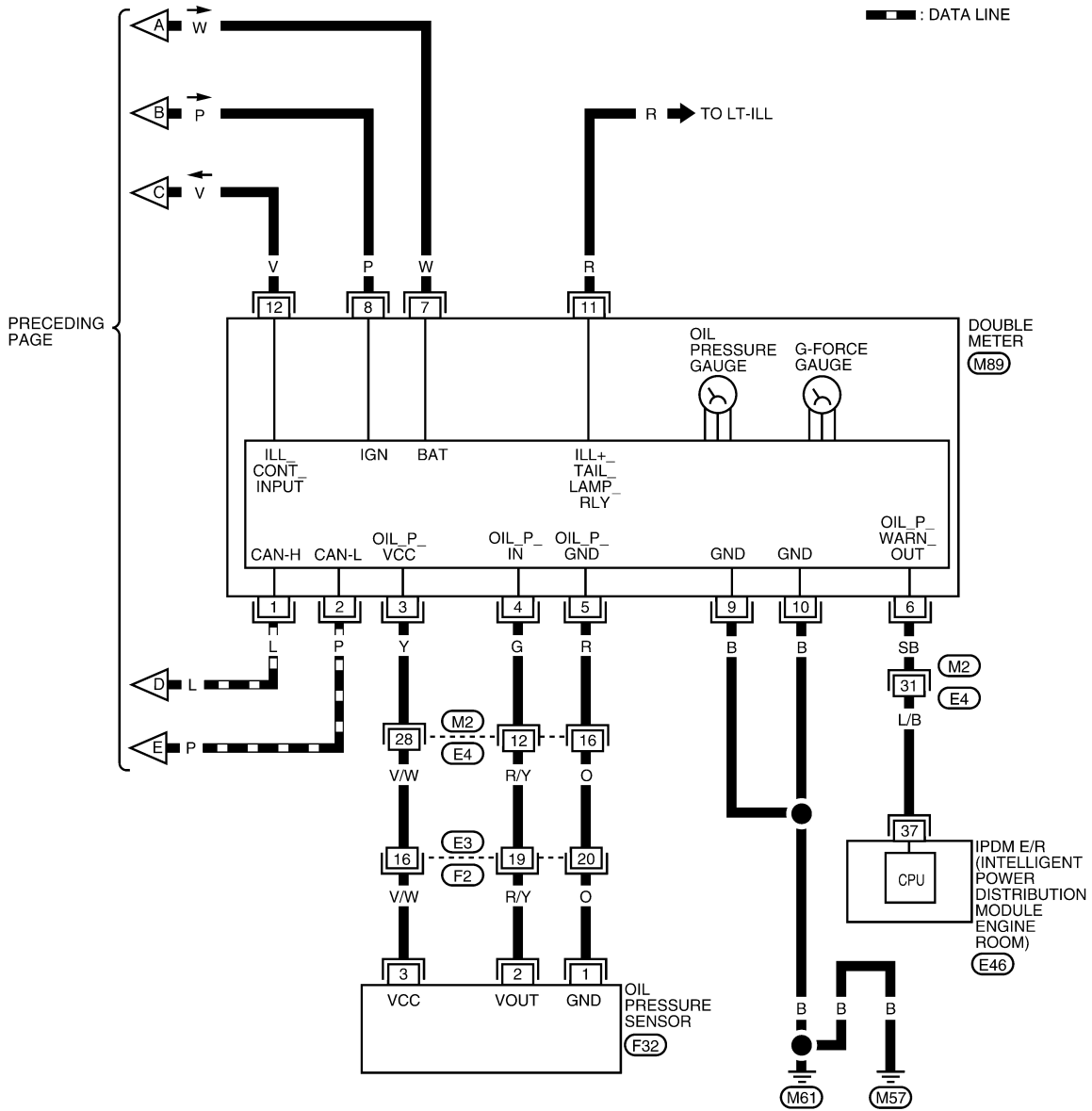

ABNWA0271GE

# DOUBLE METERS

< SERVICE INFORMATION >

## Terminal and Reference Value for Double Meter

INFOID:000000004407635

Terminal No.	Wire color	Item	Condition		Voltage (V) (Approx.)
			Ignition switch	Operation or condition	
1	L	CAN-H	—	—	—
2	P	CAN-L	—	—	—
3	Y	Oil pressure sensor power supply	ON	—	5.5
4	G	Oil pressure sensor signal	ON	When ignition switch is in the ON position. (Engine stopped)	0.5
				Engine running. [When the oil pressure is 60 psi (4.22 kg/cm <sup>2</sup> )]	2.5
5	R	Oil pressure sensor ground	ON	—	0
6	SB	Oil pressure warn out	ON	Engine oil pressure is below 4.52 psi (0.318 kg/cm <sup>2</sup> )	0.5
				Engine oil pressure is above 6.5 psi (0.457 kg/cm <sup>2</sup> )	Battery voltage
7	W	Battery power supply	OFF	—	Battery voltage
8	P	Ignition switch ON or START	ON	—	Battery voltage
9	B	Ground	ON	—	0
10					
11	R	Illumination control	—	—	Refer to <a href="#">LT-96. "System Description"</a> .
12	V	Illumination control	—	—	Refer to <a href="#">LT-96. "System Description"</a> .

## Terminal and Reference Value for Combination Meter

INFOID:000000004407636

Refer to [DI-12. "Terminal and Reference Value for Combination Meter"](#).

## CONSULT-III Function (METER/M&A)

INFOID:000000004407637

Refer to [DI-14. "CONSULT-III Function \(METER/M&A\)"](#).

## Trouble Diagnosis

INFOID:000000004407638

### HOW TO PERFORM TROUBLE DIAGNOSIS

1. Confirm the symptom or customer complaint.
2. Perform preliminary check. Refer to "PRELIMINARY CHECK".
3. According to the symptom chart, repair or replace the cause of the symptom. Refer to [DI-27. "Symptom Chart"](#).
4. Does the double meter operate normally? If so, GO TO 5. If not, GO TO 2.
5. Inspection End.

### PRELIMINARY CHECK

#### 1. CHECK COMBINATION METER (CONSULT-III)

Select "METER/M&A" on CONSULT-III and perform self-diagnosis of combination meter. Refer to [DI-14. "CONSULT-III Function \(METER/M&A\)"](#).

#### Self-diagnostic results content

No malfunction detected>>Refer to [DI-27. "Symptom Chart"](#).

Malfunction detected>>Refer to [DI-14. "CONSULT-III Function \(METER/M&A\)"](#).

# DOUBLE METERS

< SERVICE INFORMATION >

## Symptom Chart

INFOID:000000004407639

Symptom	Possible cause
Improper oil pressure gauge indication.	Refer to <a href="#">DI-27, "Oil Pressure Sensor Inspection"</a> .
Improper G-force gauge indication.	Replace double meter. Refer to <a href="#">DI-29, "Removal and Installation"</a> .
Double meter is inoperative.	<ul style="list-style-type: none"> <li>Refer to <a href="#">DI-27, "Power Supply and Ground Circuit Inspection"</a>.</li> <li>Replace double meter. Refer to <a href="#">DI-29, "Removal and Installation"</a>.</li> </ul>

## Power Supply and Ground Circuit Inspection

INFOID:000000004407640

### 1.CHECK FUSES

Check for blown double meter fuses.

Power source	Fuse No.
Battery	19
Ignition switch ON or START	14

OK or NG

OK >> GO TO 2.

NG >> If fuse is blown, be sure to eliminate cause of malfunction before installing new fuse. Refer to [PG-3](#).

### 2.CHECK POWER SUPPLY CIRCUIT

- Disconnect the double meter connector.
- Check voltage between double meter harness connector terminals and ground.

Terminals		(-)	Ignition switch position		
(+)	Connector		Terminal	OFF	ON
M89	7	Ground	Battery voltage	Battery voltage	Battery voltage
	8		0V	Battery voltage	Battery voltage

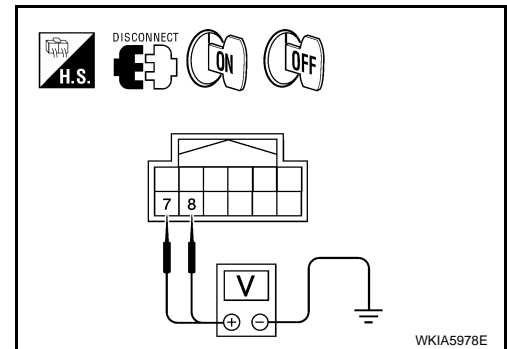

OK or NG

OK >> GO TO 3.

NG >> Check harness for open between double meter and fuse.

### 3.CHECK GROUND CIRCUIT

- Turn ignition switch OFF.
- Check continuity between double meter harness connector M89 terminals 9, 10 and ground.

**Continuity should exist.**

OK or NG

OK >> Inspection End.

NG >> Check harness or connector.

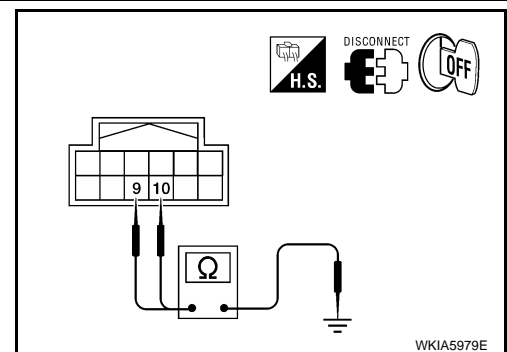

## Oil Pressure Sensor Inspection

INFOID:000000004407641

### 1.CHECK OIL PRESSURE SENSOR SIGNAL

# DOUBLE METERS

## < SERVICE INFORMATION >

1. Turn ignition switch ON.
2. Check voltage between double meter harness connector M89 terminal 4 and ground.

Terminals			Condition	Voltage (Approx.)
(+)		(-)		
Connector	Terminal			
M89	4	Ground	When ignition switch is in ON position. (Engine stopped.)	0.5V
			Engine running. [When the oil pressure is 60 psi (4.22 kg/cm <sup>2</sup> )]	2.5V

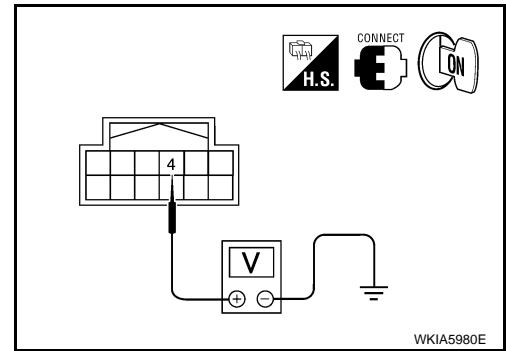

### OK or NG

- OK >> Replace double meter. Refer to [DI-29. "Removal and Installation"](#).  
 NG >> GO TO 2.

## 2.CHECK OIL PRESSURE SENSOR POWER SUPPLY

Check voltage between double meter harness connector M89 terminal 3 and ground.

**Approx. 5.5V**

### OK or NG

- OK >> GO TO 3.  
 NG >> Replace double meter. Refer to [DI-29. "Removal and Installation"](#).

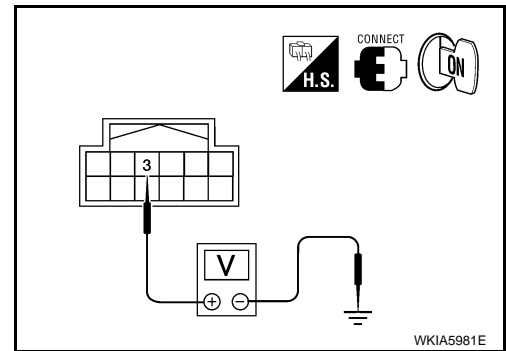

## 3.CHECK OIL PRESSURE SENSOR POWER SUPPLY CIRCUIT

1. Turn ignition switch OFF.
2. Disconnect double meter and oil pressure sensor connectors.
3. Check continuity between double meter harness connector M89 (A) terminal 3 and oil pressure sensor harness connector F32 (B) terminal 3.

**Continuity should exist.**

4. Check continuity between double meter harness connector M89 (A) terminal 3 and ground.

**Continuity should not exist.**

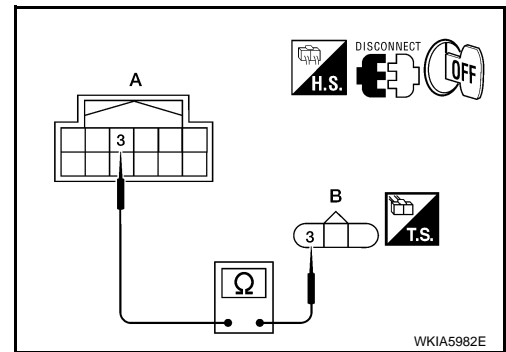

### OK or NG

- OK >> GO TO 4.  
 NG >> Repair harness or connector between double meter and oil pressure sensor.

## 4.CHECK OIL PRESSURE SENSOR SIGNAL CIRCUIT

# DOUBLE METERS

## < SERVICE INFORMATION >

1. Check continuity between double meter harness connector M89 (B) terminal 4 and oil pressure sensor harness connector F32 (A) terminal 2.

**Continuity should exist.**

2. Check continuity between double meter harness connector M89 (B) terminal 4 and ground.

**Continuity should not exist.**

### OK or NG

OK >> GO TO 5.

NG >> Repair harness or connector between double meter and oil pressure sensor.

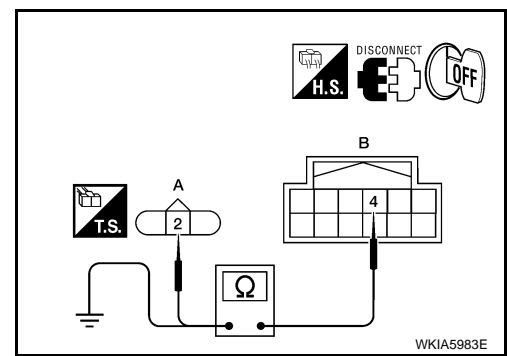

## 5. CHECK OIL PRESSURE SENSOR GROUND CIRCUIT

Check continuity between double meter harness connector M89 (A) terminal 5 and oil pressure sensor harness connector F32 (B) terminal 1.

**Continuity should exist.**

### OK or NG

OK >> Replace oil pressure sensor.

NG >> Repair harness or connector between double meter and oil pressure sensor.

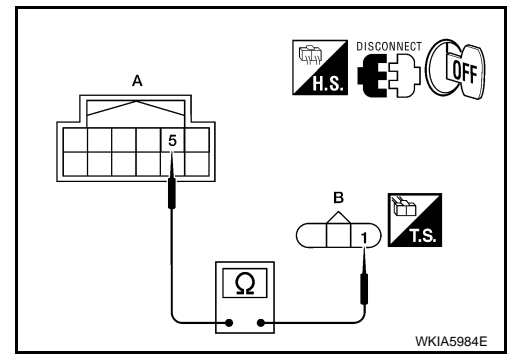

## Removal and Installation

INFOID:000000004407642

## COMPONENTS

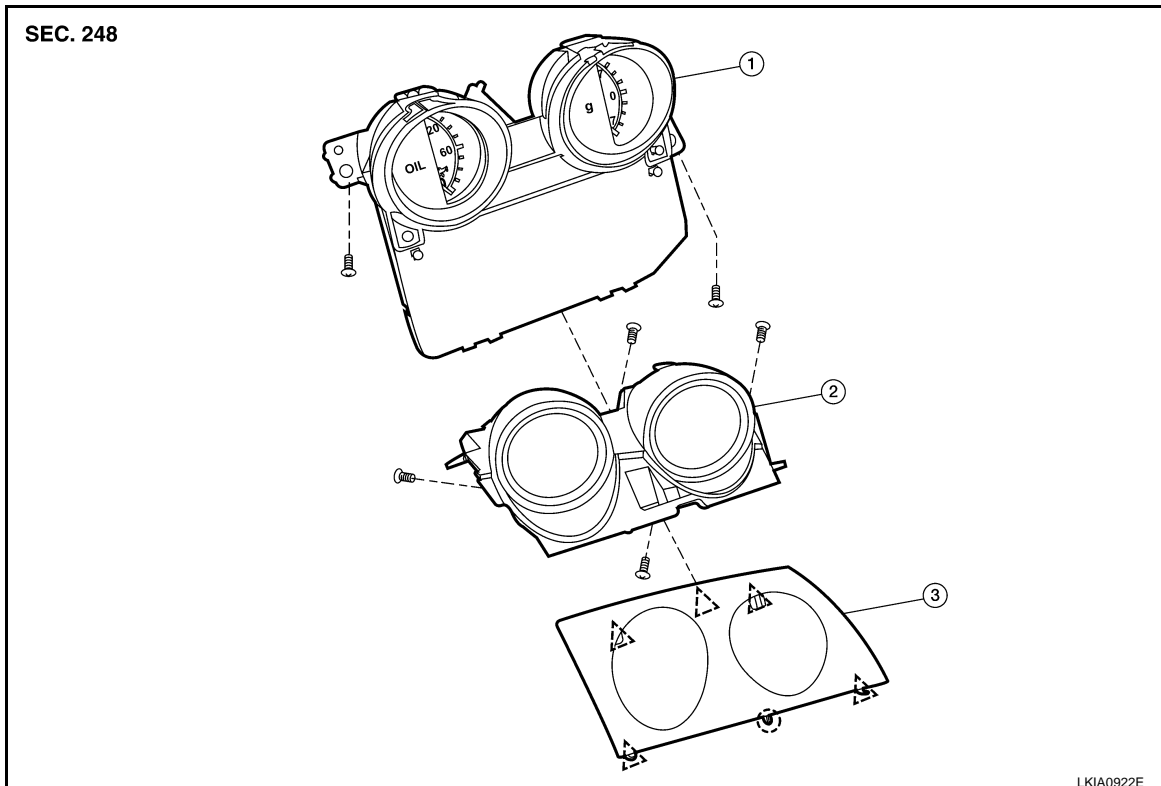

1. Double meter

2. Upper housing

3. Double meter finisher

△ Clip

○ Pawl

A  
B  
C  
D  
E  
F  
G  
H  
I  
J  
L  
M  
N  
O  
P

DI

## DOUBLE METERS

### < SERVICE INFORMATION >

#### REMOVAL

1. Carefully remove the double meter assembly (1) using suitable tool.

**CAUTION:**

Wrap suitable tool with clean shop cloth to prevent damage to the instrument panel.

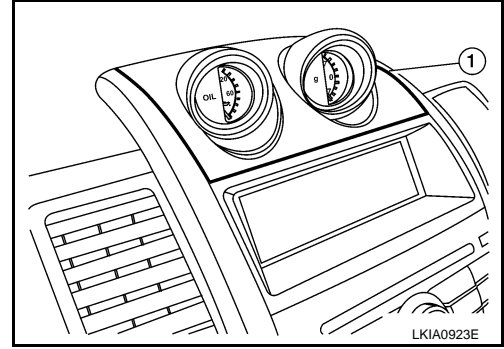

2. Disconnect the double meter assembly connector (1) and remove the double meter assembly (2).

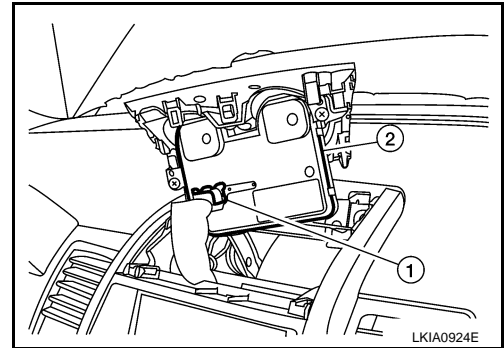

#### INSTALLATION

Installation is in the reverse order of removal.

# WARNING LAMPS

< SERVICE INFORMATION >

## WARNING LAMPS

### Schematic

INFOID:000000004407643

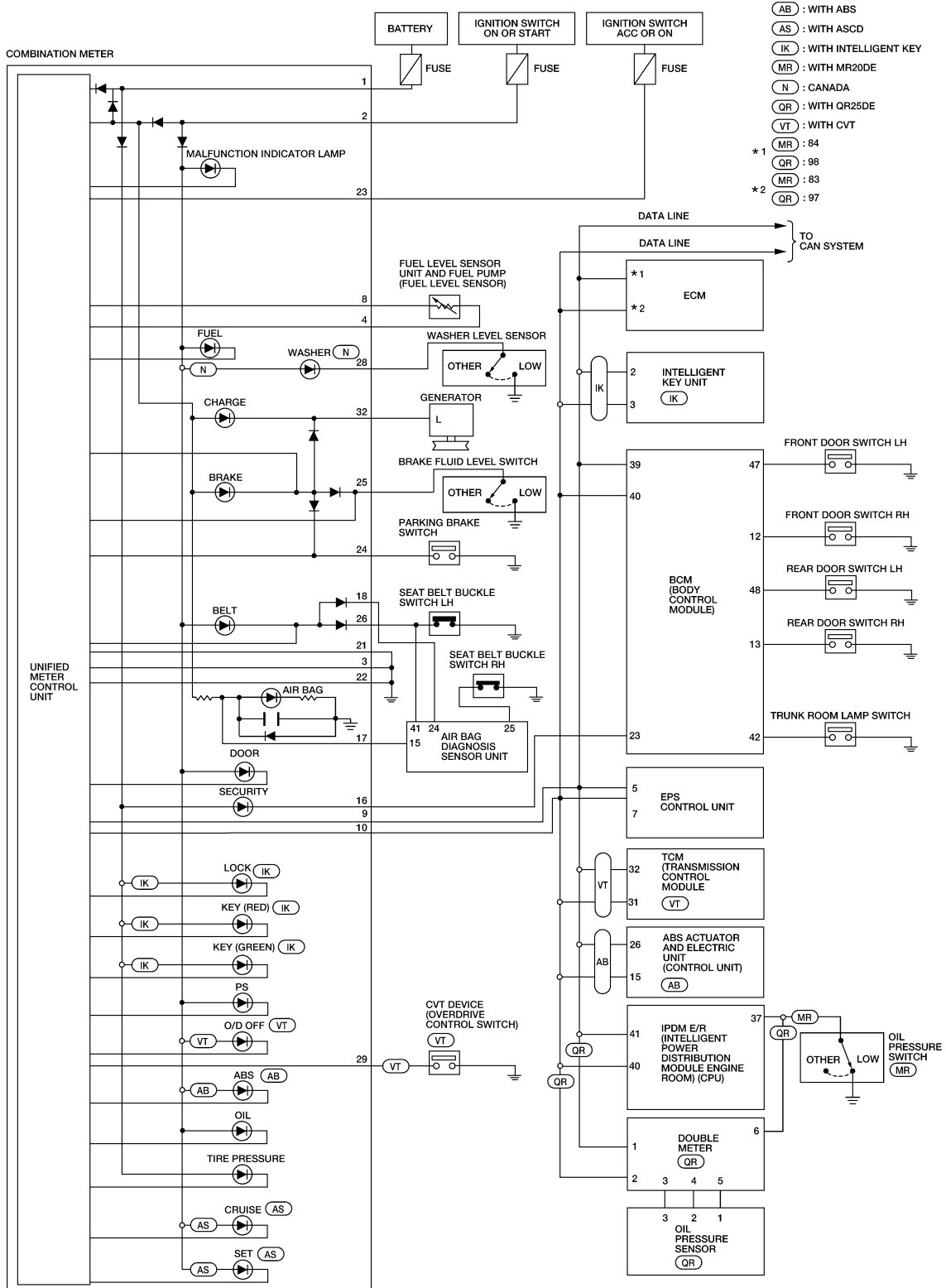

AWMWA0095G

A  
B  
C  
D  
E  
F  
G  
H  
I  
J  
K  
L  
M  
N  
O  
P

DI

# WARNING LAMPS

< SERVICE INFORMATION >

## Wiring Diagram - WARN -

INFOID:000000004407644

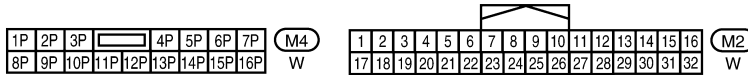
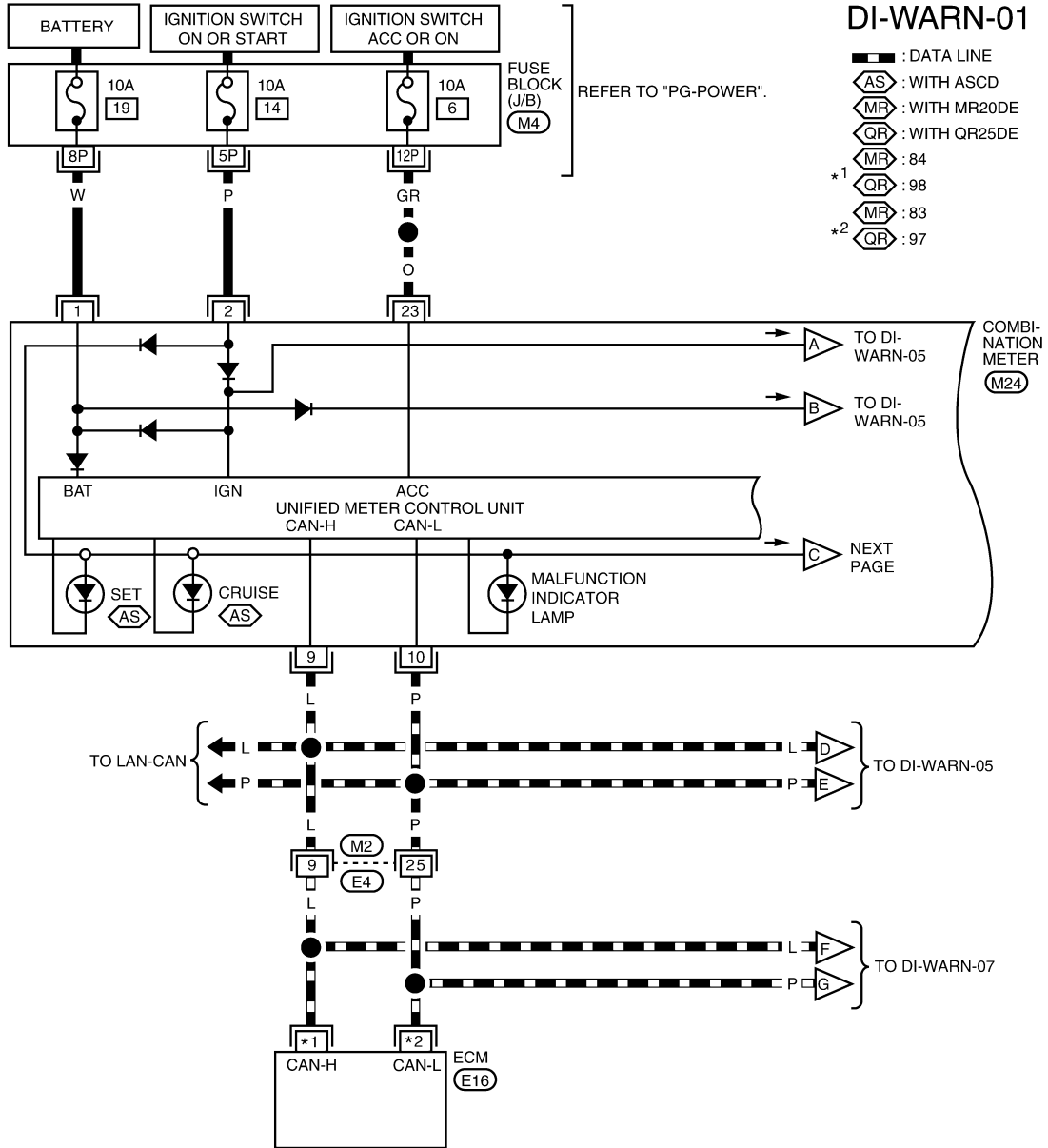

REFER TO THE FOLLOWING.  
(M31) - SUPER MULTIPLE JUNCTION (SMJ)

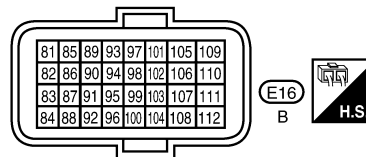
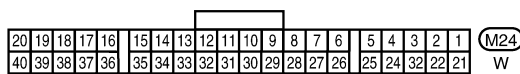

AWMWA0096G



# WARNING LAMPS

< SERVICE INFORMATION >

DI-WARN-02

MR : WITH MR20DE

N : CANADA

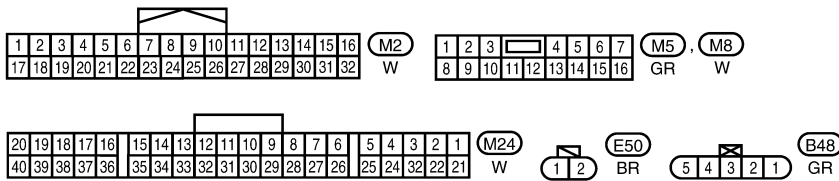
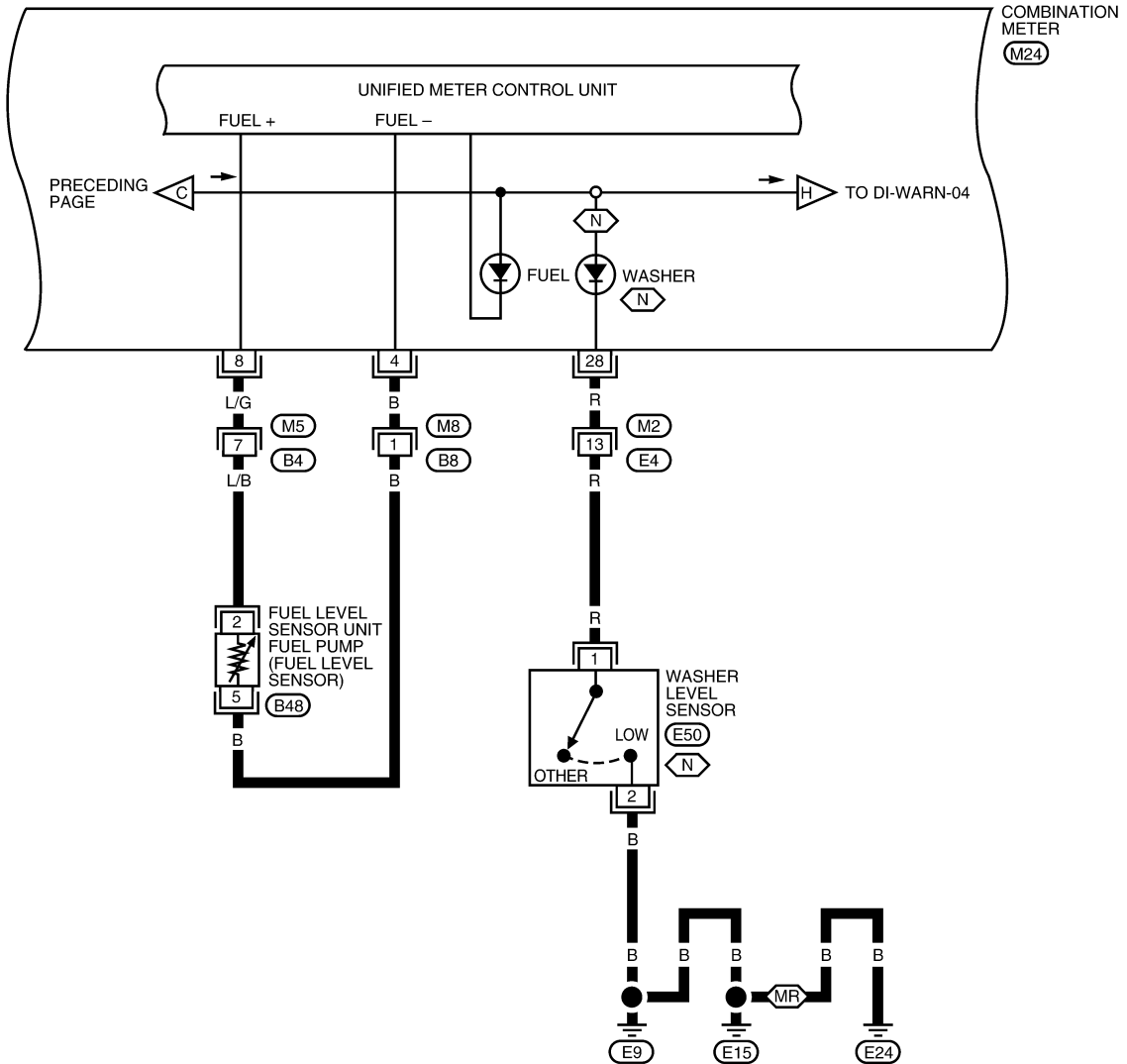

WKWA5764E

# WARNING LAMPS

< SERVICE INFORMATION >

DI-WARN-03

MR : WITH MR20DE

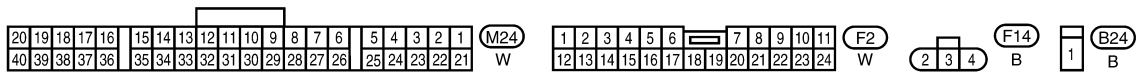
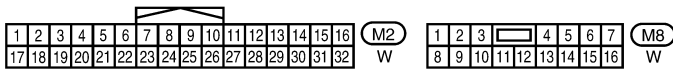
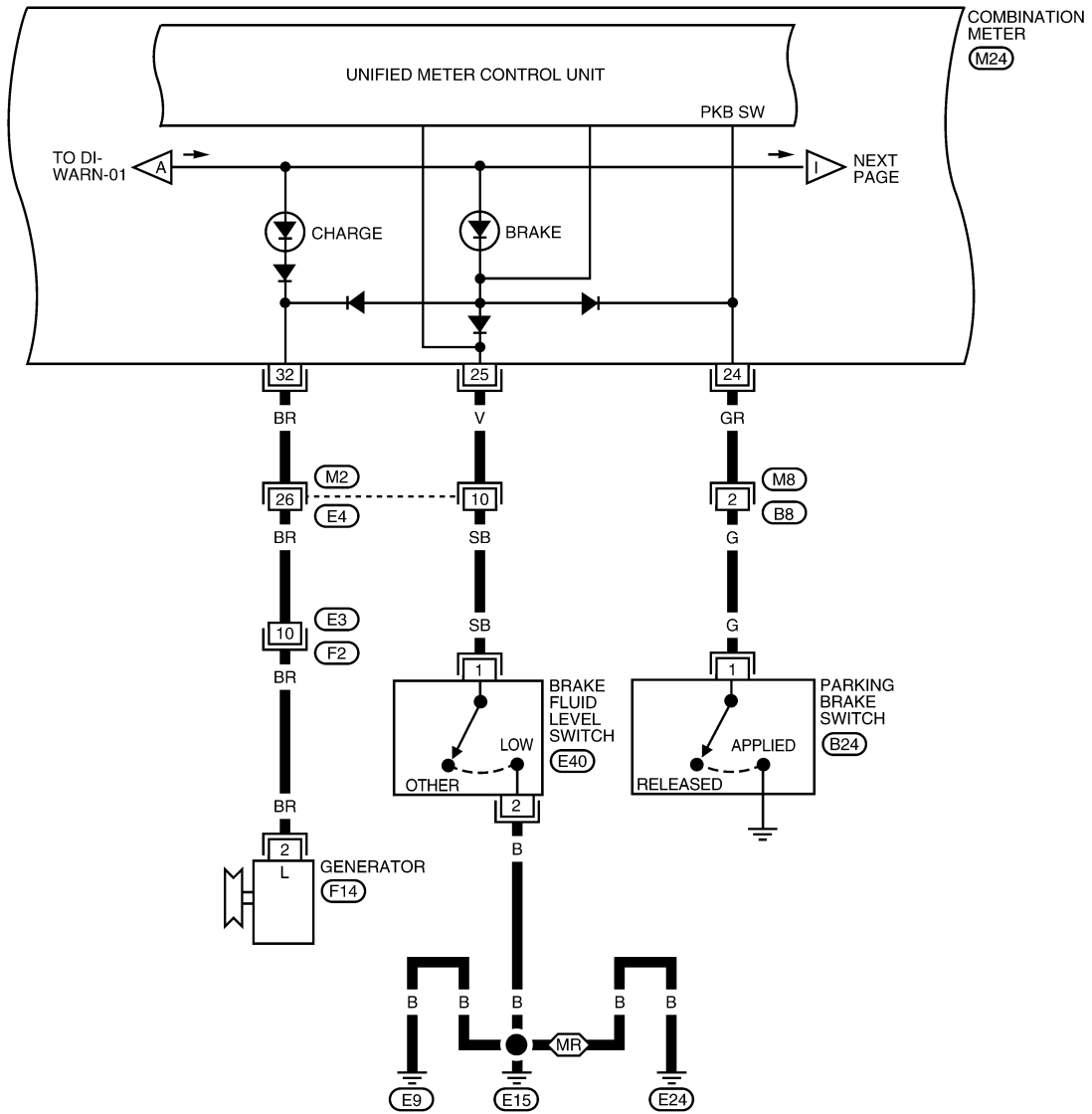

ABNWA0272GI

# WARNING LAMPS

< SERVICE INFORMATION >

DI-WARN-04

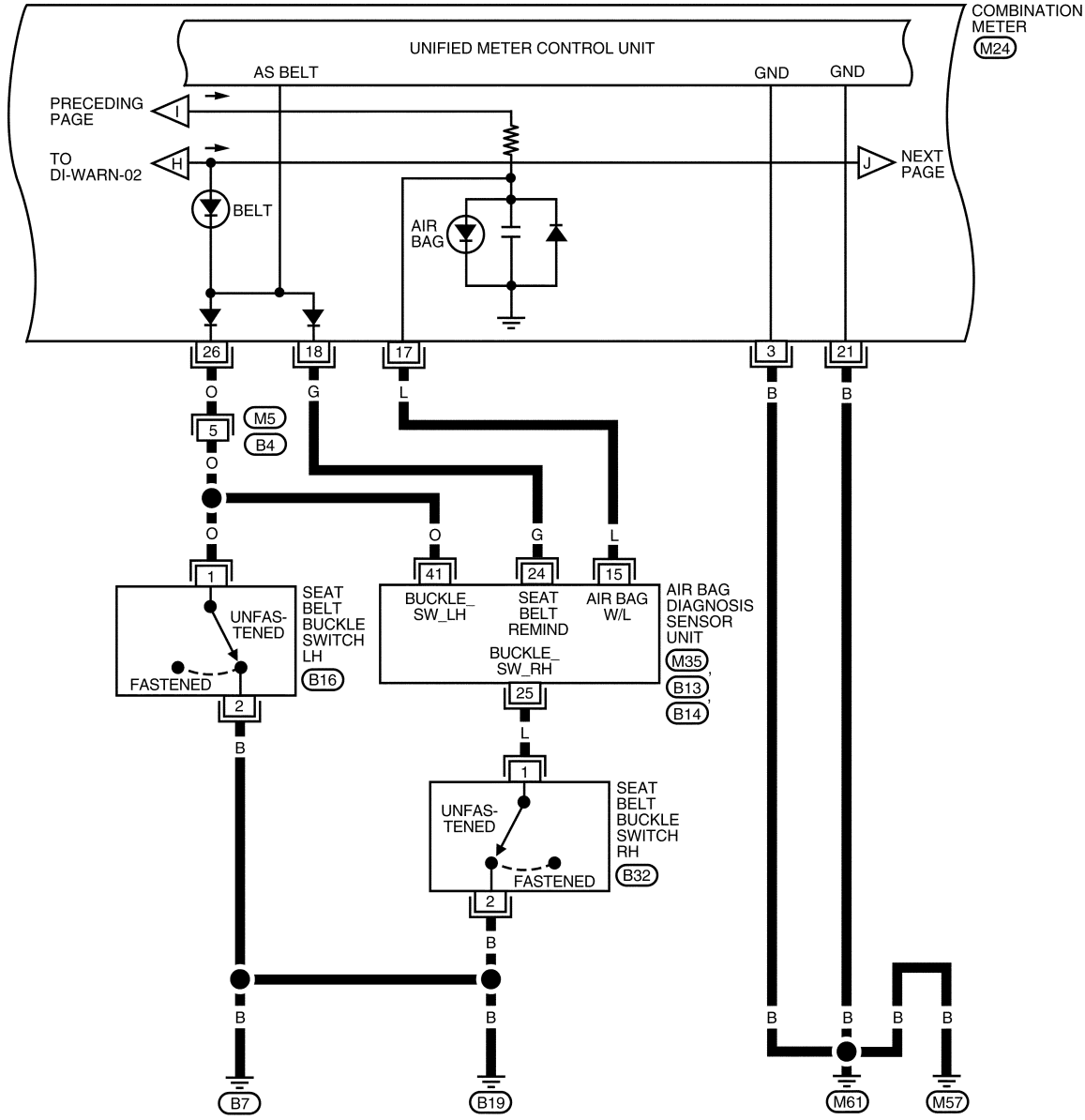

1	2	3	4	5	6	7	M5	20	19	18	17	16	15	14	13	12	11	10	9	8	7	6	5	4	3	2	1	M24
8	9	10	11	12	13	14	GR	40	39	38	37	36	35	34	33	32	31	30	29	28	27	26	25	24	32	22	21	W

1	49	24	21	M35	31	25	27	28	32	B13	34	30	29	41	33	B14
5	6	4	3	Y	40	35	36	7	8	Y	10	9	38	37	44	Y
2	18															

1
2
3

B16, B32  
W W

WKWA5857E

A  
B  
C  
D  
E  
F  
G  
H  
I  
J  
DI  
L  
M  
N  
O  
P

# WARNING LAMPS

< SERVICE INFORMATION >

DI-WARN-05

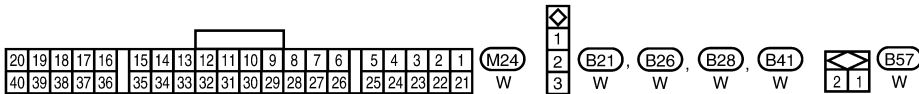
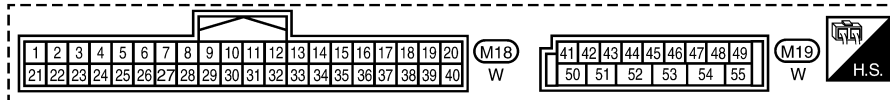
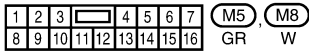
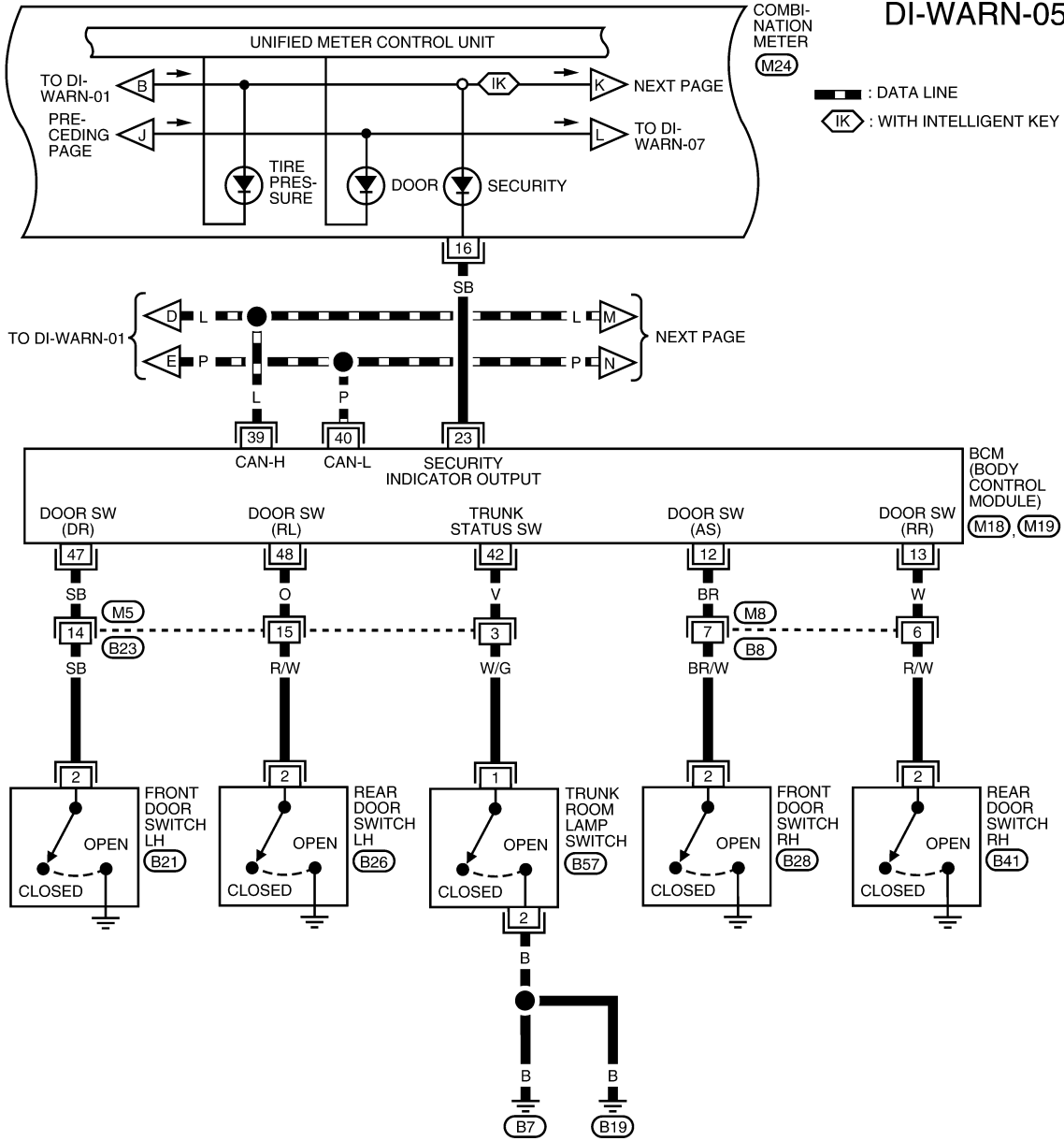



WKWA5423E

# WARNING LAMPS

< SERVICE INFORMATION >

DI-WARN-06

 : DATA LINE  
 : WITH INTELLIGENT KEY

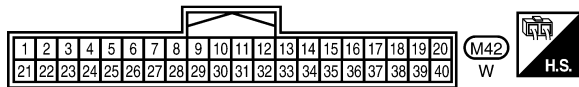
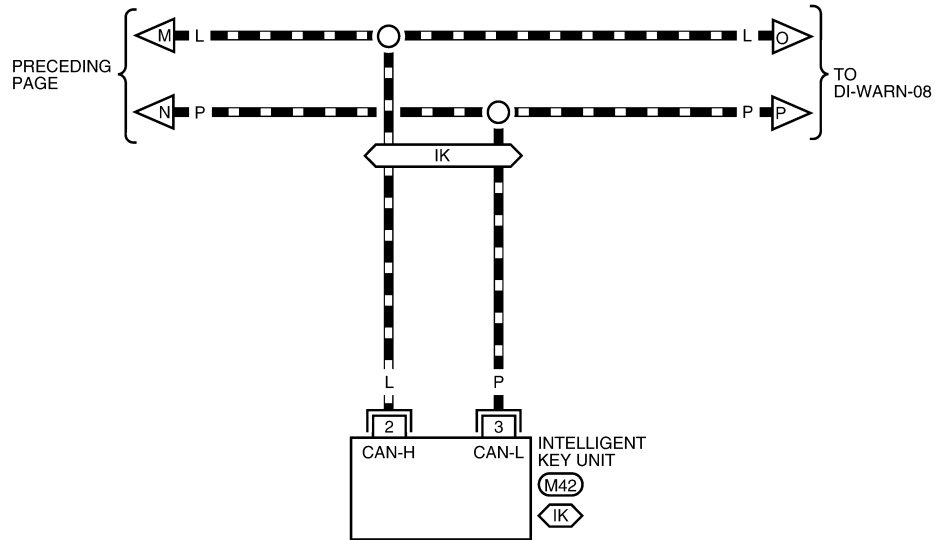
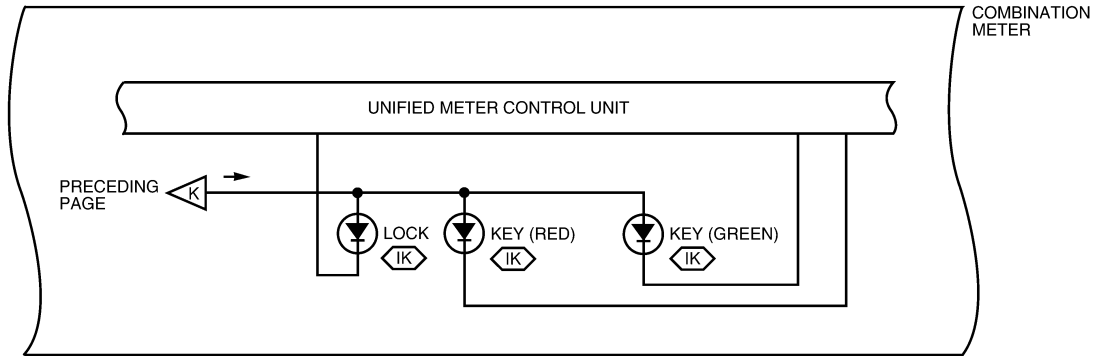

WKWA5424E

# WARNING LAMPS

< SERVICE INFORMATION >

## DI-WARN-07

- : DATA LINE
- AB : WITH ABS
- IK : WITH INTELLIGENT KEY
- OK : WITHOUT INTELLIGENT KEY
- VT : WITH CVT

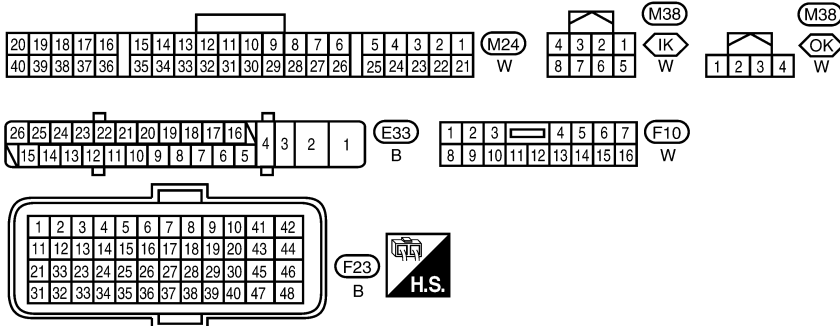
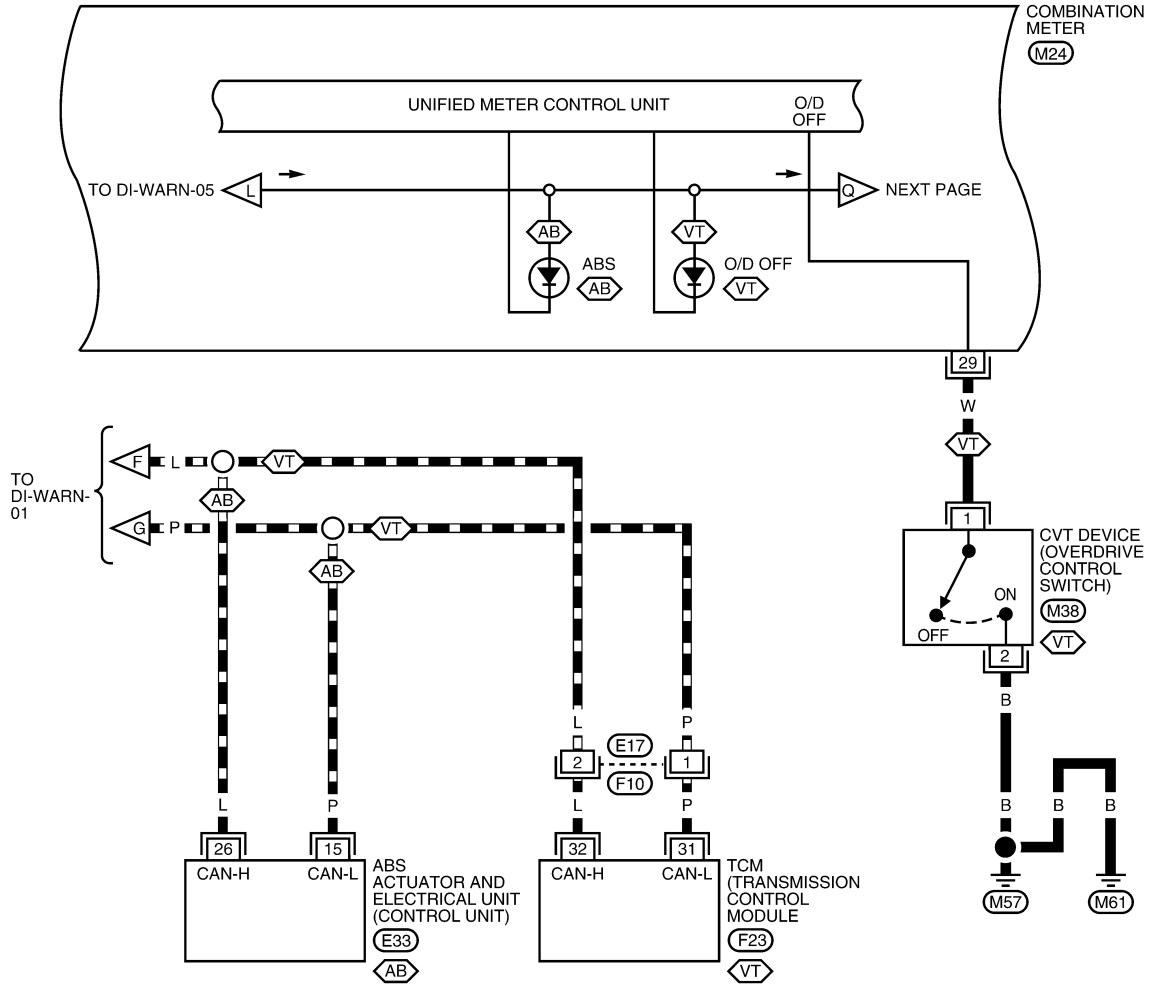

AWMWA0098G

# WARNING LAMPS

< SERVICE INFORMATION >

DI-WARN-08

- MR : WITH MR20DE
- QR : WITH QR25DE
- \*1 MR : V
- QR : SB

DATA LINE

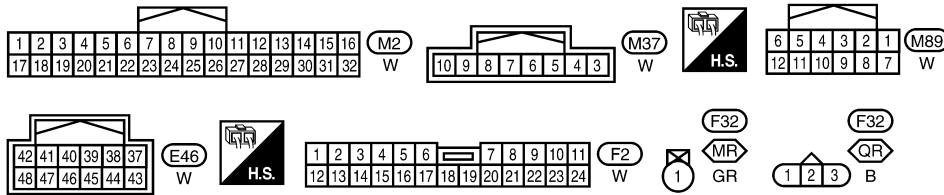
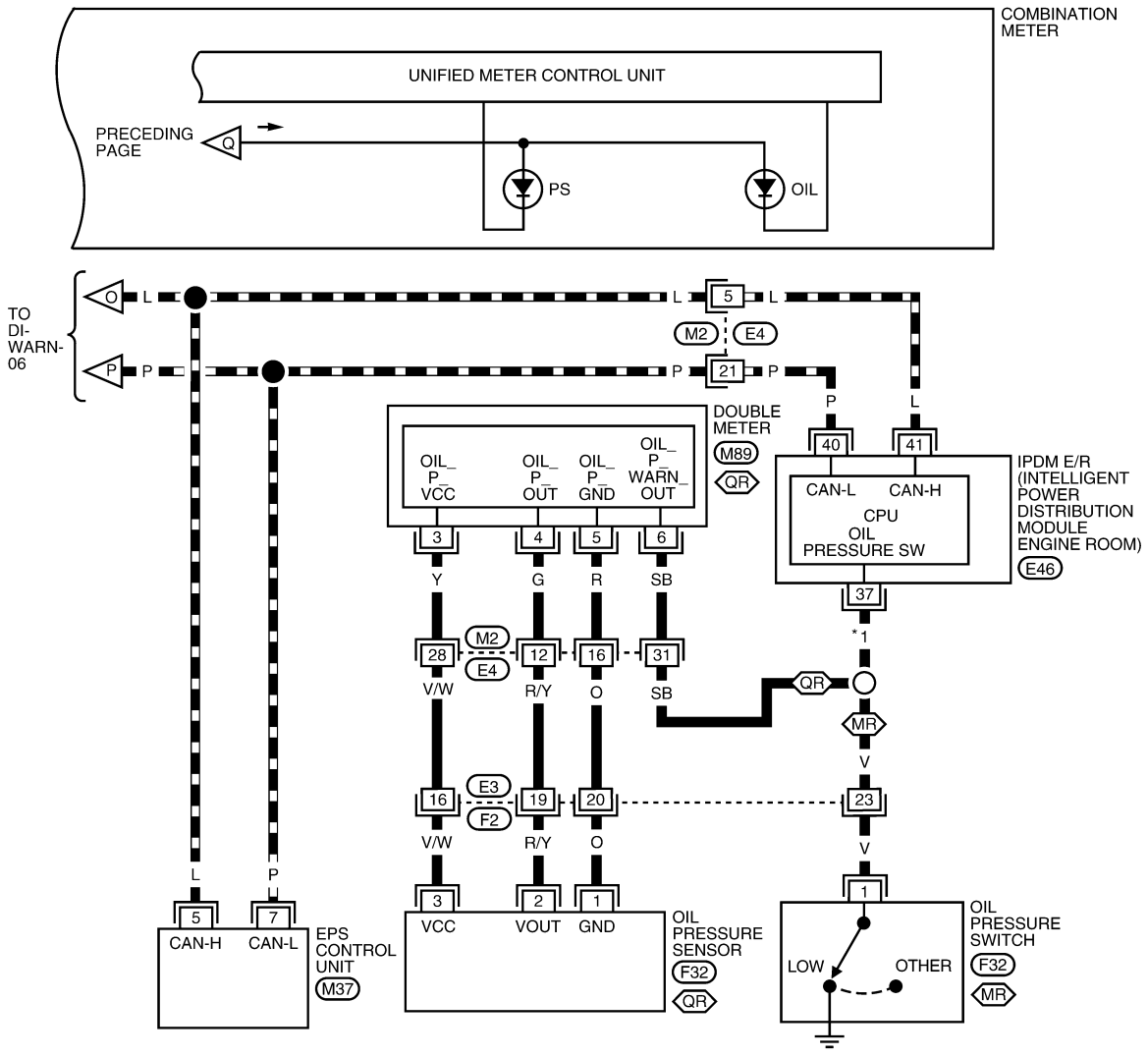

## Oil Pressure Warning Lamp Stays Off (Ignition Switch ON)

### 1. CHECK OIL PRESSURE WARNING LAMP OPERATION

Activate IPDM E/R auto active test. Refer to [PG-20. "Auto Active Test"](#).

Does oil pressure warning lamp blink?

- YES >> GO TO 2.
- NO >> GO TO 5.

# WARNING LAMPS

< SERVICE INFORMATION >

## 2. CHECK IPDM E/R INPUT SIGNAL

1. Turn ignition switch ON.
2. Check voltage between IPDM E/R harness connector and ground.

Terminals		Condition	Voltage (Approx.)
(+)			
IPDM E/R connector	Terminal	(-)	
E46	37	Ground	0V

OK or NG

OK >> Replace IPDM E/R. Refer to [PG-27, "Removal and Installation of IPDM E/R"](#).

NG >> GO TO 3.

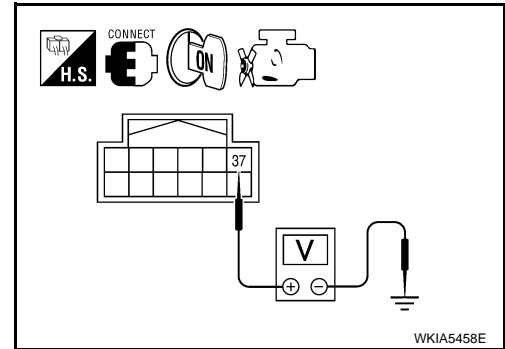

## 3. CHECK OIL PRESSURE CIRCUIT

1. Disconnect IPDM E/R connector and oil pressure switch connector (with MR20DE) or double meter connector (with QR25DE).
2. Check continuity between IPDM E/R harness connector E46 (A) terminal 37 and oil pressure switch harness connector F32 (B) terminal 1 (with MR20DE) or double meter connector M89 (C) terminal 6 (with QR25DE).

**With MR20DE**

**37 - 1 : Continuity should exist**

**With QR25DE**

**37 - 6 : Continuity should exist**

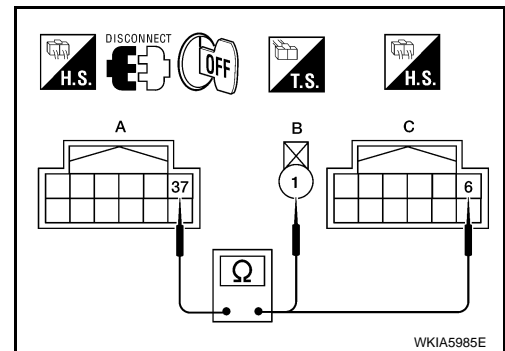

OK or NG

OK >> With MR20DE, GO TO 4. With QR25DE, refer to [DI-27, "Oil Pressure Sensor Inspection"](#).

NG >> Repair harness or connector.

## 4. CHECK OIL PRESSURE SWITCH

Check oil pressure switch. Refer to [DI-42, "Component Inspection"](#).

OK or NG

OK >> Replace IPDM E/R. Refer to [PG-27, "Removal and Installation of IPDM E/R"](#).

NG >> Replace oil pressure switch.

## 5. CHECK CAN COMMUNICATION

Select "METER/M&A" on CONSULT-III, and perform self-diagnosis of combination meter.

Self-diagnostic results content

No malfunction detected>> GO TO 6.

Malfunction detected>> Check applicable parts, and repair or replace as necessary.

## 6. CHECK COMBINATION METER INPUT SIGNAL

Select "METER/M&A" on CONSULT-III. Operate ignition switch with "OIL W/L" of "DATA MONITOR" and check operation status.

**"OIL W/L"**

**When ignition switch is in ON position (Engine stopped) : ON**

**When engine running : OFF**

OK or NG

OK >> Replace combination meter. Refer to [IP-12, "Removal and Installation"](#).



# WARNING LAMPS

## < SERVICE INFORMATION >

NG >> GO TO 7.

### 7. CHECK BCM INPUT SIGNAL

Select "BCM" on CONSULT-III. Then select "SIGNAL BUFFER". Operate ignition switch with "OIL PRESS SW" of "DATA MONITOR" and check operation status.

#### "OIL PRESS SW"

When ignition switch is in ON : ON  
position (Engine stopped.)

When engine running : OFF

#### OK or NG

OK >> Replace BCM. Refer to [BCS-17, "Removal and Installation of BCM"](#).

NG >> Replace IPDM E/R. Refer to [PG-27, "Removal and Installation of IPDM E/R"](#).

### Oil Pressure Warning Lamp Does Not Turn Off (Oil Pressure Is Normal)

INFOID:000000004407646

#### NOTE:

For oil pressure inspection, refer to [LU-5, "Inspection"](#) (MR20DE) or [LU-16, "Inspection"](#) (QR25DE).

### 1. CHECK OIL PRESSURE WARNING LAMP OPERATION

Activate IPDM E/R auto active test. Refer to [PG-20, "Auto Active Test"](#).

Does oil pressure warning lamp blink?

YES >> GO TO 2.

NO >> GO TO 5.

### 2. CHECK IPDM E/R OUTPUT SIGNAL

1. Turn ignition switch OFF.
2. Disconnect oil pressure switch connector (with MR20DE) or double meter connector (with QR25DE).
3. Turn ignition switch ON.
4. Check voltage between oil pressure switch harness connector F32 (A) terminal 1 (with MR20DE) or double meter connector M89 (B) terminal 6 (with QR25DE) and ground.

#### With MR20DE

1 - ground : Battery voltage

#### With QR25DE

6 - ground : Battery voltage

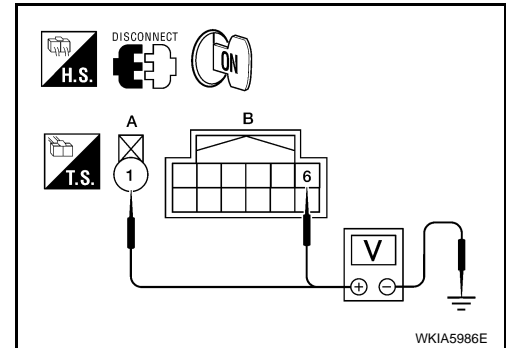

#### OK or NG

OK >> With MR20DE, GO TO 3. With QR25DE, refer to [DI-27, "Oil Pressure Sensor Inspection"](#).

NG >> GO TO 4.

### 3. CHECK OIL PRESSURE SWITCH

1. Turn ignition switch OFF.
2. Check oil pressure switch. Refer to [DI-42, "Component Inspection"](#).

#### OK or NG

OK >> Replace IPDM E/R. Refer to [PG-27, "Removal and Installation of IPDM E/R"](#).

NG >> Replace oil pressure switch.

### 4. CHECK OIL PRESSURE CIRCUIT

1. Disconnect IPDM E/R connector and oil pressure switch connector (with MR20DE) or double meter connector (with QR25DE).

# WARNING LAMPS

## < SERVICE INFORMATION >

2. Check continuity between IPDM E/R harness connector E46 (A) terminal 37 and oil pressure switch harness connector F32 (B) terminal 1 (with MR20DE) or double meter connector M89 (C) terminal 6 (with QR25DE).

**With MR20DE**

**37 - 1**

**: Continuity should exist**

**With QR25DE**

**37 - 6**

**: Continuity should exist**

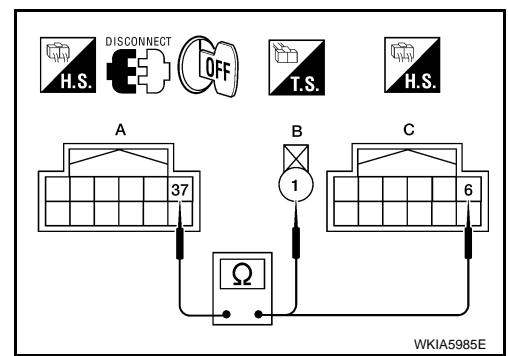

### OK or NG

OK >> Replace IPDM E/R. Refer to [PG-27, "Removal and Installation of IPDM E/R"](#).

NG >> Repair harness or connector.

## 5. CHECK BCM INPUT SIGNAL

Select "BCM" on CONSULT-III. Then select "SIGNAL BUFFER". Operate ignition switch with "OIL PRESS SW" of "DATA MONITOR" and check operation status.

**"OIL PRESS SW"**

**When ignition switch is in ON : ON**  
**position (Engine stopped.)**

**When engine running : OFF**

### OK or NG

OK >> Replace BCM. Refer to [BCS-17, "Removal and Installation of BCM"](#).

NG >> Replace IPDM E/R. Refer to [PG-27, "Removal and Installation of IPDM E/R"](#).

## Component Inspection

INFOID:000000004407647

### OIL PRESSURE SWITCH

Check continuity between oil pressure switch and ground.

Condition	Oil pressure [kPa (bar, kg/cm <sup>2</sup> , psi)]	Continuity
Engine stopped	Less than 29 (0.3, 0.3, 4)	Yes
Engine running	More than 29 (0.3, 0.3, 4)	No

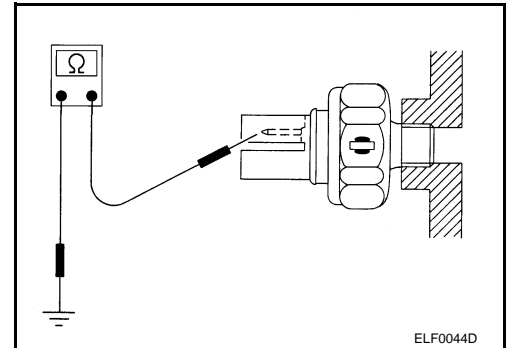

# CVT INDICATOR

< SERVICE INFORMATION >

## CVT INDICATOR

### System Description

INFOID:000000004407648

The TCM receives CVT indicator signals from the park/neutral position (PNP) switch. The TCM then sends CVT position indicator signals to the combination meter via CAN communication lines. The combination meter indicates the received shift position.

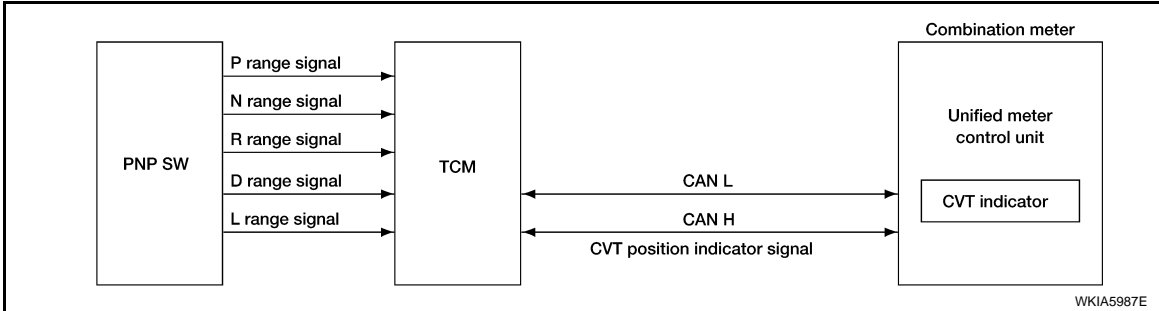

A  
B  
C  
D  
E  
F  
G  
H  
I  
J  
L  
M  
N  
O  
P

DI

# CVT INDICATOR

< SERVICE INFORMATION >

## Wiring Diagram - CVTIND -

INFOID:000000004407649

DI-CVTIND-01

▬ : DATA LINE

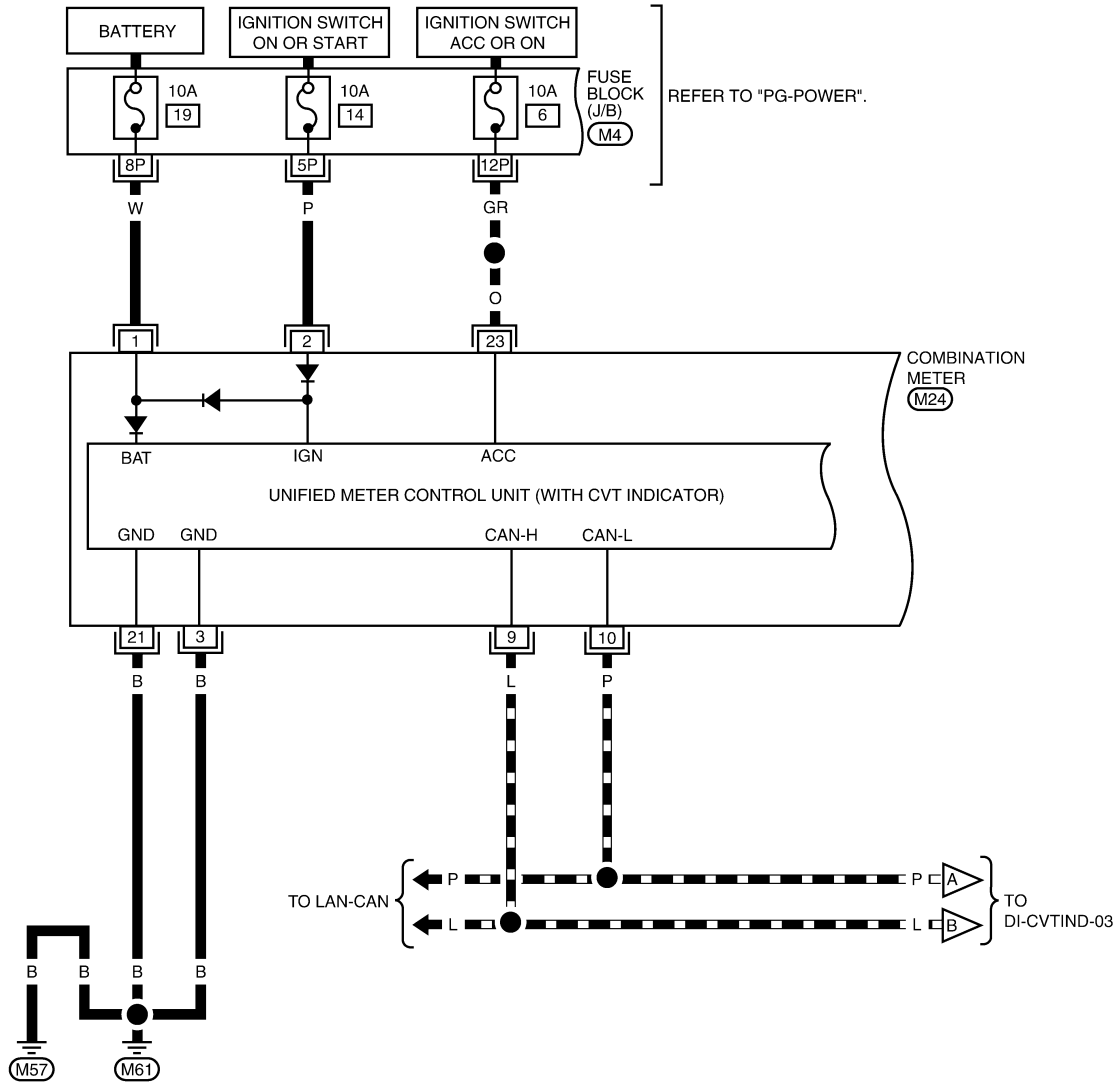

1P	2P	3P	4P	5P	6P	7P	M4	20	19	18	17	16	15	14	13	12	11	10	9	8	7	6	5	4	3	2	1	M24		
8P	9P	10P	11P	12P	13P	14P	15P	16P	W	40	39	38	37	36	35	34	33	32	31	30	29	28	27	26	25	24	23	22	21	W

AWMWA0100G

# CVT INDICATOR

< SERVICE INFORMATION >

DI-CVTIND-02

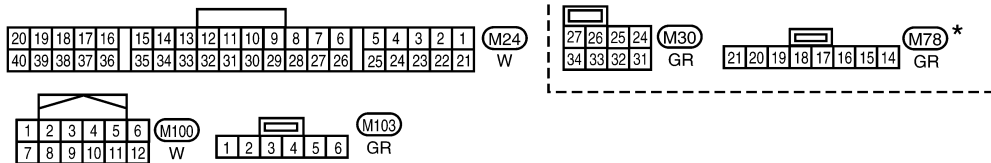
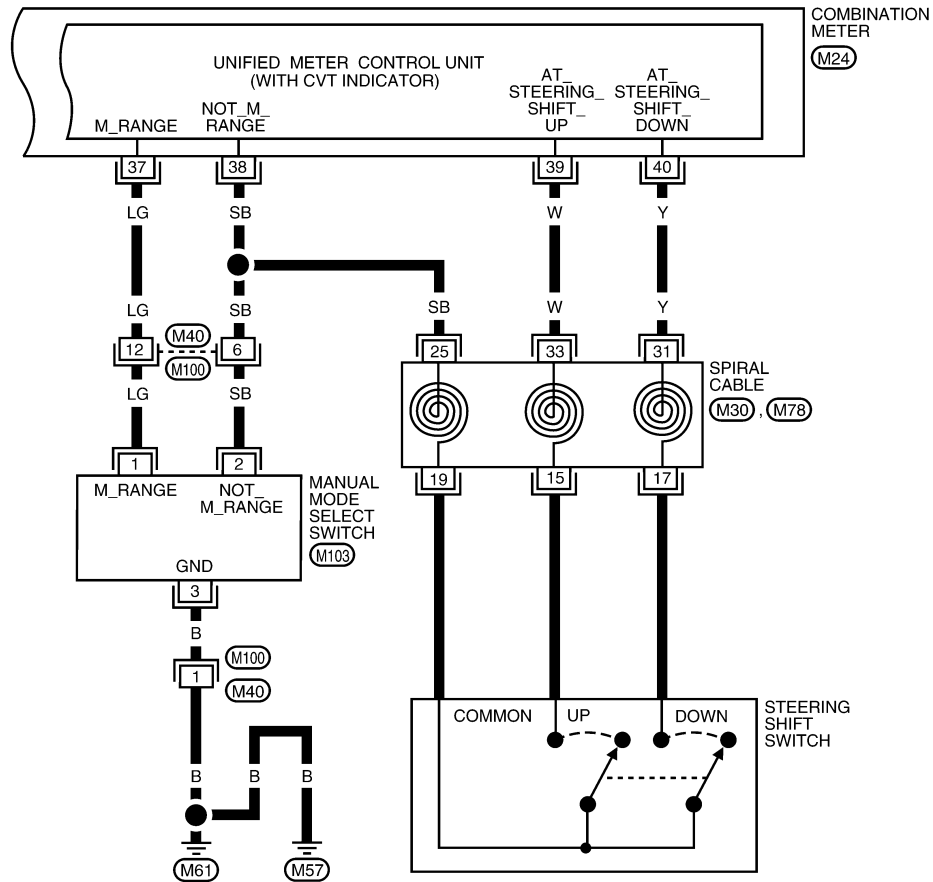

\*: THIS CONNECTOR IS NOT SHOWN IN "HARNESS LAYOUT" OF PG SECTION.

AWMWA0101G

# CVT INDICATOR

< SERVICE INFORMATION >

DI-CVTIND-03

— : DATA LINE

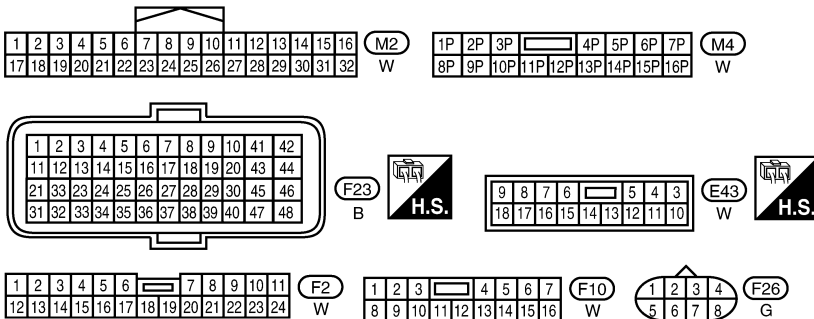
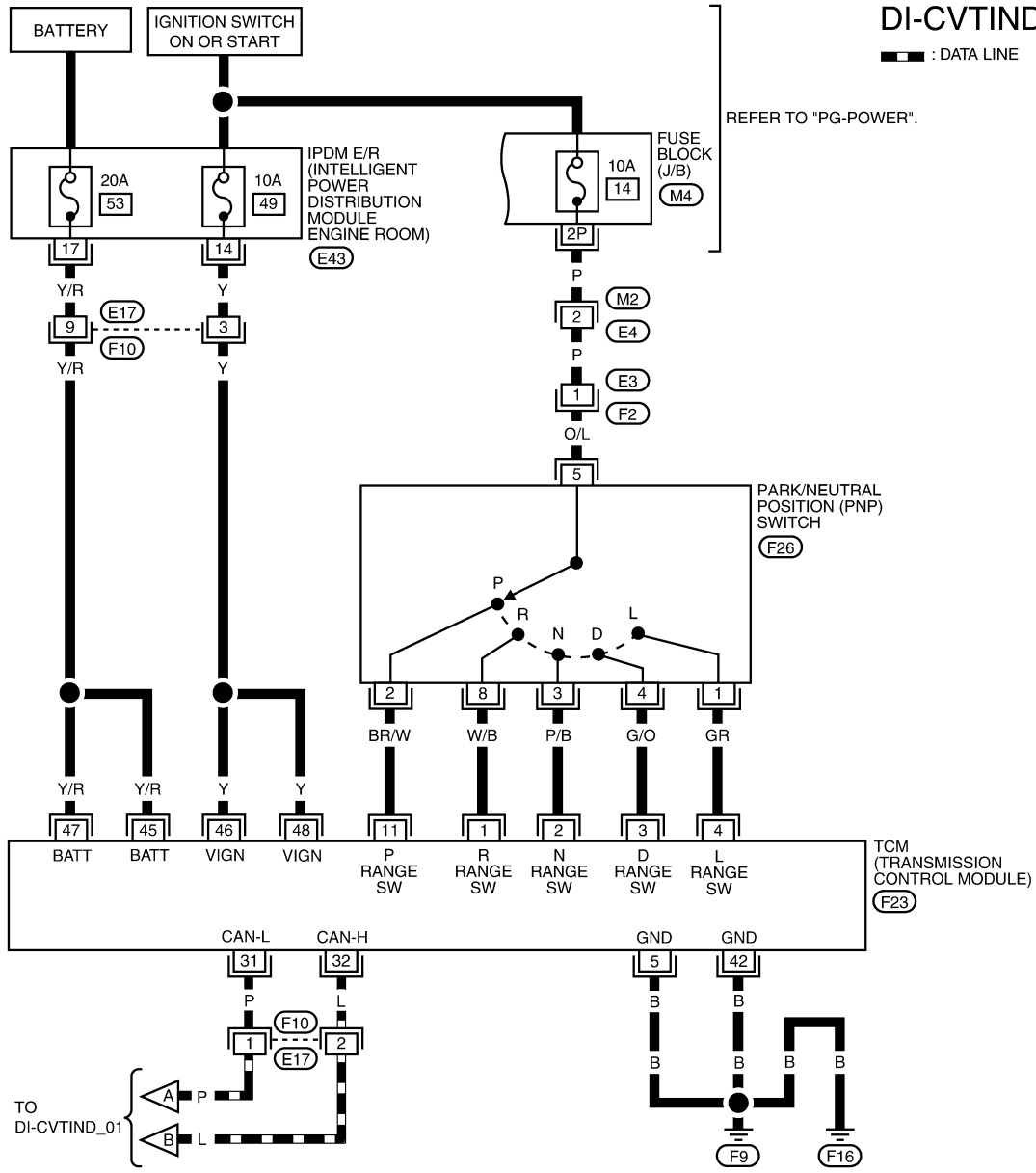

AWMWA0102G

INFOID:000000004407650

CVT Indicator Does Not Illuminate

1. CHECK SEGMENT OF CVT INDICATOR

# CVT INDICATOR

## < SERVICE INFORMATION >

Perform self-diagnosis of combination meter. Refer to [DI-13, "Self-Diagnosis Mode of Combination Meter"](#).

Are all segments displayed?

YES >> GO TO 2.

NO >> Replace combination meter. Refer to [IP-12, "Removal and Installation"](#).

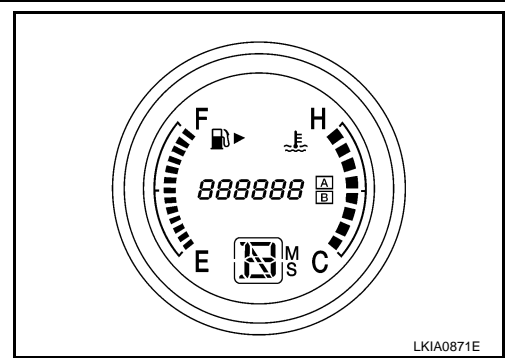

## 2. CHECK COMBINATION METER (CONSULT-III)

1. Connect CONSULT-III.

2. Select "METER/M&A" on CONSULT-III, and perform self-diagnosis of combination meter. Refer to [DI-14, "CONSULT-III Function \(METER/M&A\)"](#).

Self-diagnostic results content

No malfunction detected>> GO TO 3.

Malfunction detected>> Check applicable parts, and repair or replace as necessary.

## 3. CHECK COMBINATION METER INPUT SIGNAL

Use "DATA MONITOR" of "METER/M&A" on CONSULT-III. Confirm each indication on the monitor while operating the CVT selector lever.

CONSULT-III display	Switch operation	Operation status
P RANGE IND	P range position	ON
	Except for P range position	OFF
R RANGE IND	R range position	ON
	Except for R range position	OFF
N RANGE IND	N range position	ON
	Except for N range position	OFF
D RANGE IND	D range position	ON
	Except for D range position	OFF
L RANGE IND	L range position	ON
	Except for L range position	OFF

OK or NG

OK >> Replace combination meter. Refer to [IP-12, "Removal and Installation"](#).

NG >> GO TO 4.

## 4. CHECK SELF-DIAGNOSIS RESULTS OF TCM

Perform self-diagnosis of TCM. Refer to [CVT-47, "CONSULT-III Function \(TRANSMISSION\)"](#).

OK or NG

OK >> Check TCM input/output signal. Repair or replace malfunctioning part, if necessary. Refer to [CVT-45, "TCM Input/Output Signal Reference Value"](#).

NG >> Check applicable part, and repair or replace as necessary.

# WARNING CHIME

< SERVICE INFORMATION >

## WARNING CHIME

### Component Parts and Harness Connector Location

INFOID:000000004407651



LKIA0877E



# WARNING CHIME

## < SERVICE INFORMATION >

- |   |  |   |
|---|--|---|
| 1. Combination meter M24                                  | 2. Combination switch M28  | 3. Key switch and ignition knob switch M49 (with Intelligent Key) |
| 4. Key switch M50 (without Intelligent Key)               | 5. Front door switch LH B21                                      | 6. Seat belt buckle switch LH B16                                 |
| 7. BCM M18, M19, M20 (view with instrument panel removed) | 8. Intelligent Key unit M42 (view with instrument panel removed) | 9. Parking brake switch B24                                       |

## System Description

INFOID:000000004407652

- Buzzer for warning chime system is installed in the combination meter.
- The buzzer sounds when combination meter receives buzzer output signal with CAN communication line.

## POWER SUPPLY AND GROUND CIRCUIT

Power is supplied at all times

- through 50A fusible link (letter j, located in the fuse and fusible link box)
- to BCM terminal 70,
- through 10A fuse [No. 21, located in the fuse block (J/B)]
- to BCM terminal 57,
- through 10A fuse [No. 19, located in the fuse block (J/B)]
- to combination meter terminal 1 and
- to key switch (without Intelligent Key) terminal 2,
- through 10A fuse [No. 9, located in the fuse block (J/B)]
- to key switch and ignition knob switch (with Intelligent Key) terminals 2 and 4.

With ignition switch in the ON or START position, power is supplied

- through 10A fuse [No. 12, located in the fuse block (J/B)]
- to BCM terminal 38,
- through 10A fuse [No. 14, located in the fuse block (J/B)]
- to combination meter terminal 2.

With ignition switch in the ACC or ON position, power is supplied

- through 10A fuse [No. 6, located in the fuse block (J/B)]
- to combination meter terminal 23.

Ground is supplied

- to BCM terminal 67 and
- to combination meter terminals 3 and 21
- through grounds M57 and M61.

## IGNITION KEY WARNING CHIME (WITHOUT INTELLIGENT KEY)

With the key inserted into the key switch, and the ignition switch in the OFF or ACC position, when driver's door is opened, the warning chime will sound.

- BCM detects key inserted into the ignition switch, and sends key warning signal to combination meter with CAN communication line.
- When combination meter receives key warning signal, it sounds warning chime.

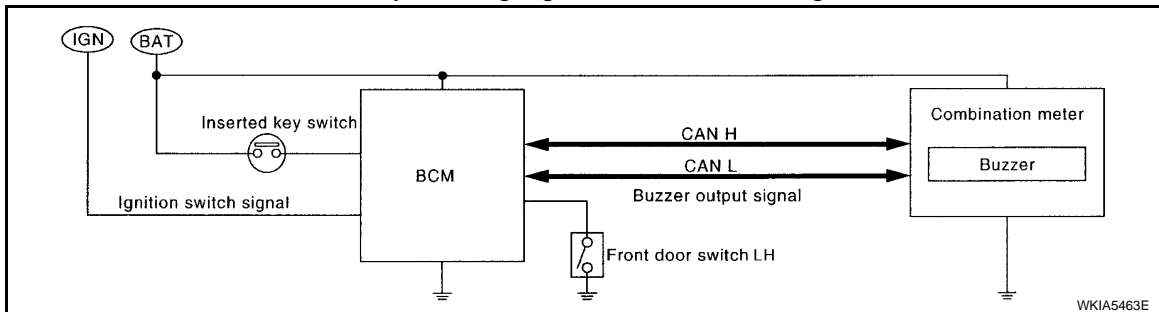

## IGNITION KEY WARNING CHIME (WITH INTELLIGENT KEY)

When Mechanical Key Is Used

With the key inserted into the key switch, and the ignition switch in the LOCK or ACC position, when driver's door is opened, the warning chime will sound.

- BCM detects key inserted into the ignition switch, and sends key warning signal to combination meter with CAN communication line.

# WARNING CHIME

## < SERVICE INFORMATION >

- When combination meter receives key warning signal, it sounds warning chime.

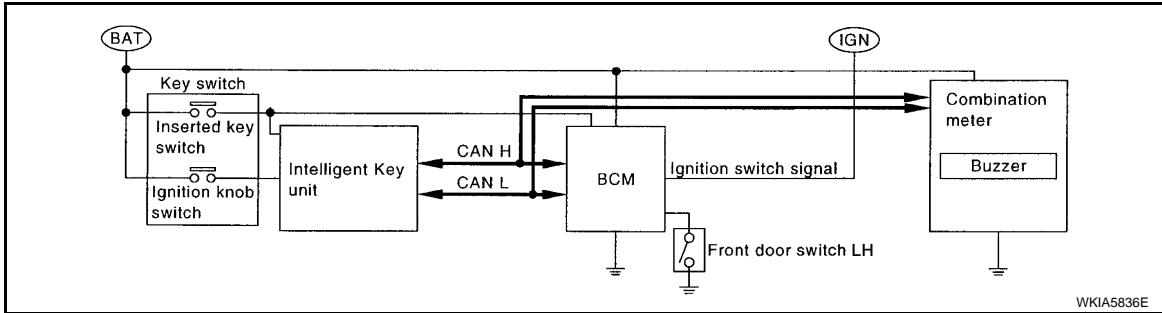

When Intelligent Key Is Carried With The Driver  
Refer to [BL-72. "System Description"](#).

## LIGHT WARNING CHIME

The warning chime sounds, when driver's door is opened (door switch ON) with lighting switch ON and the ignition switch is in any position other than ON or START.

### NOTE:

BCM detected lighting switch in the 1st or 2nd position, refer to [LT-59. "Combination Switch Reading Function"](#).

- BCM detects headlamps are illuminated, and sends light warning signal to combination meter with CAN communication lines.
- When the combination meter receives light warning signal, it sounds warning chime.

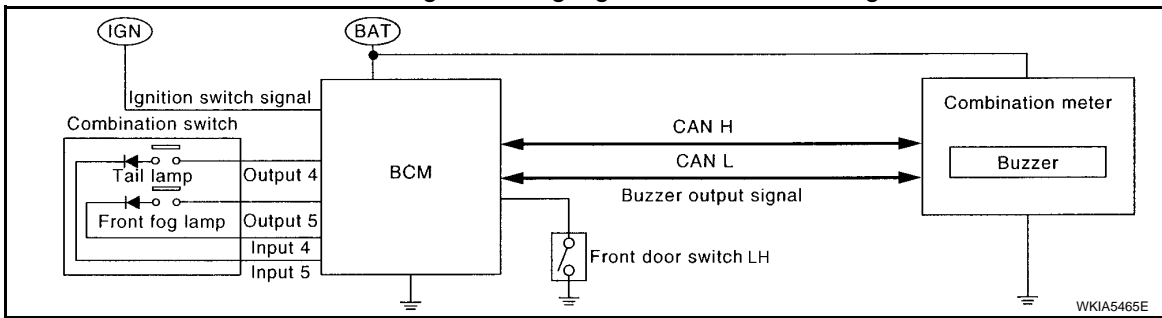

## SEAT BELT WARNING CHIME

With the ignition switch turned ON and driver's seat belt unfastened, the seat belt warning chime will sound for approximately 6 seconds.

- The combination meter reads an ON/OFF signal from the seat belt buckle switch LH, and transmits the seat belt buckle switch signal to the BCM with CAN communication.
- The BCM detects the ignition switch turned ON and seat belt buckle switch LH ON. And then, transmits the buzzer output signal (seat belt warning chime) to the combination meter with CAN communication.
- When the combination meter receives the buzzer output signal (seat belt warning chime), it sounds the buzzer.

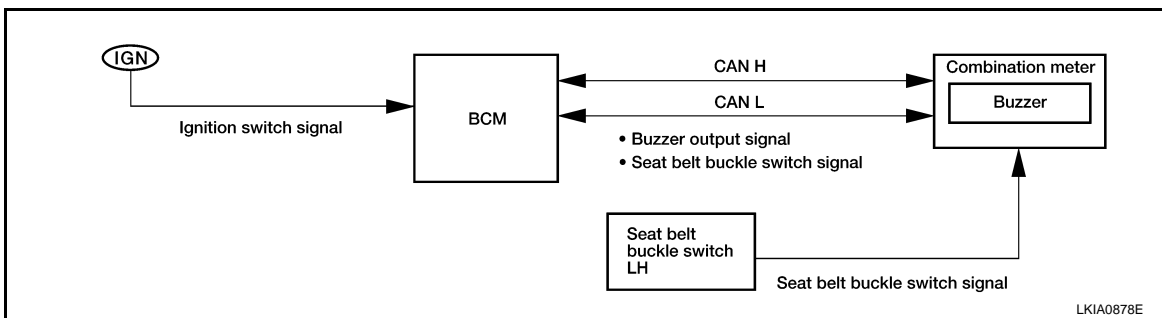

## PARKING BRAKE WARNING CHIME

The parking brake warning chime sounds when the parking brake is applied and vehicle speed reaches approximately 2 km/h (1 MPH).

- The combination meter receives a parking brake applied signal from the parking brake switch.

# WARNING CHIME

## < SERVICE INFORMATION >

- When the combination meter receives a vehicle speed signal from the ABS actuator and electric unit (control unit) (with ABS), vehicle speed sensor (without ABS or CVT) or the TCM (with CVT, without ABS), it sounds the buzzer.

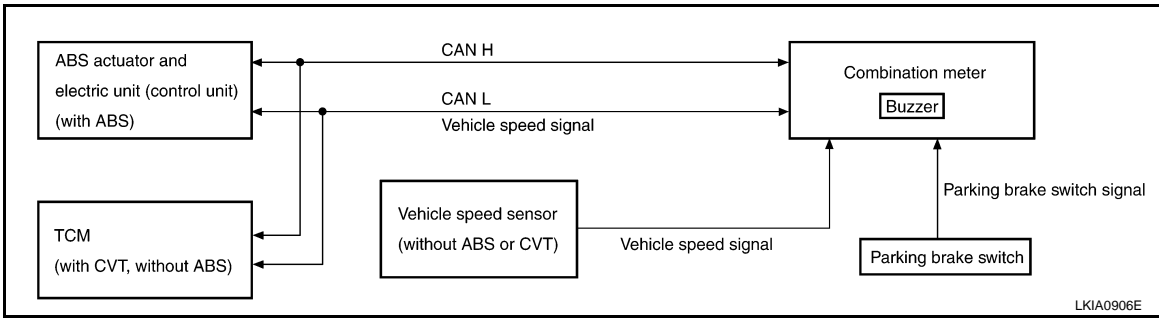

A  
B  
C  
D  
E  
F  
G  
H  
I  
J  
DI  
L  
M  
N  
O  
P

# WARNING CHIME

< SERVICE INFORMATION >

## Wiring Diagram - CHIME -

INFOID:000000004407653

### DI-CHIME-01

IK : WITH INTELLIGENT KEY  
OK : WITHOUT INTELLIGENT KEY

REFER TO "PG-POWER".

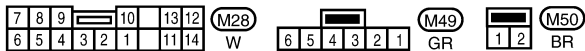
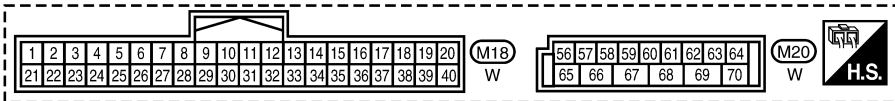
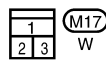
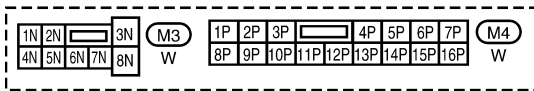
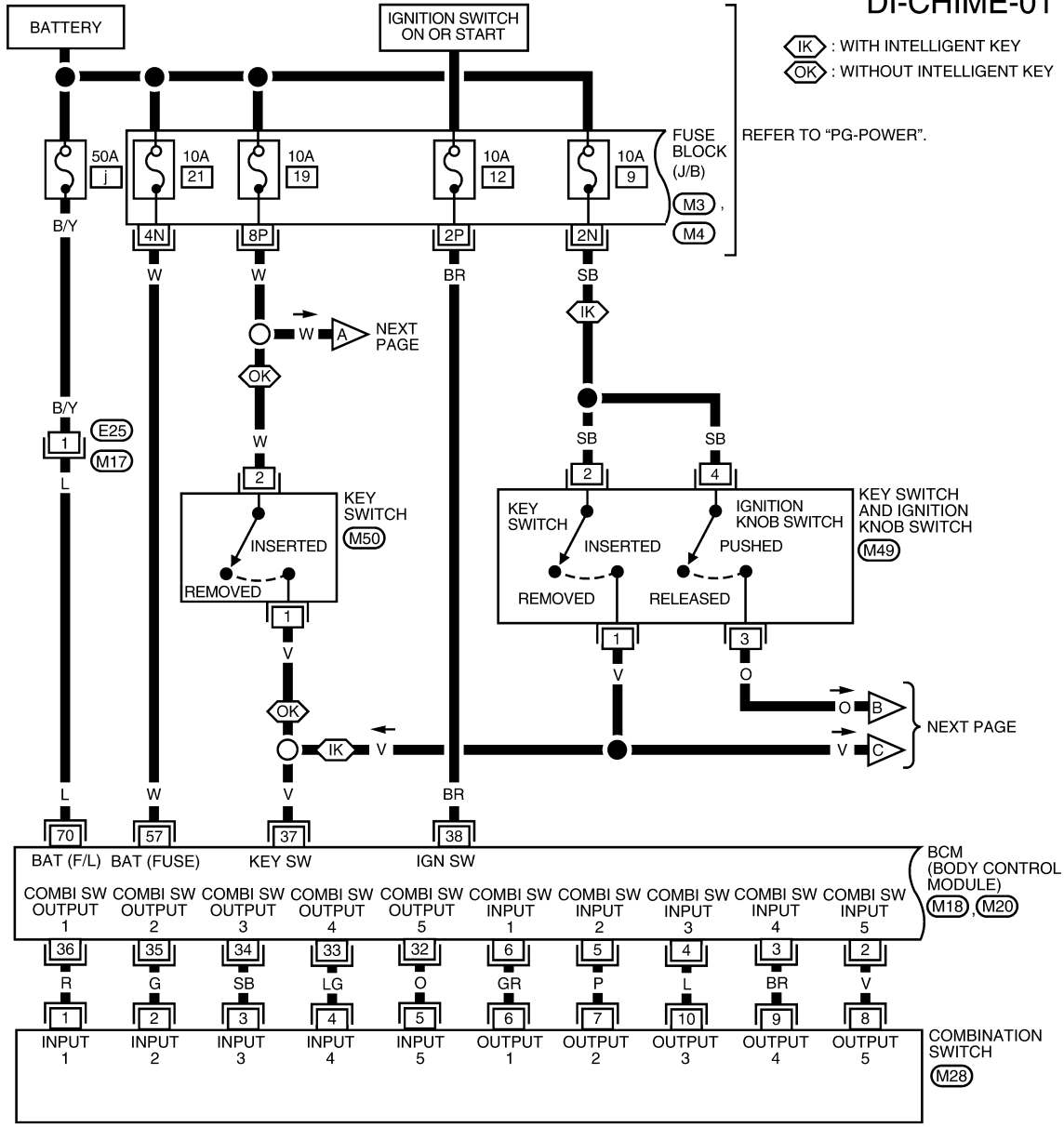

WKWA5429E

# WARNING CHIME

< SERVICE INFORMATION >

DI-CHIME-02

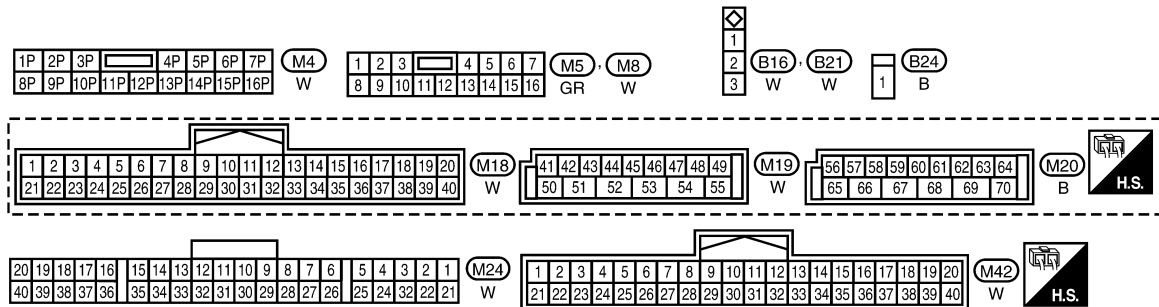
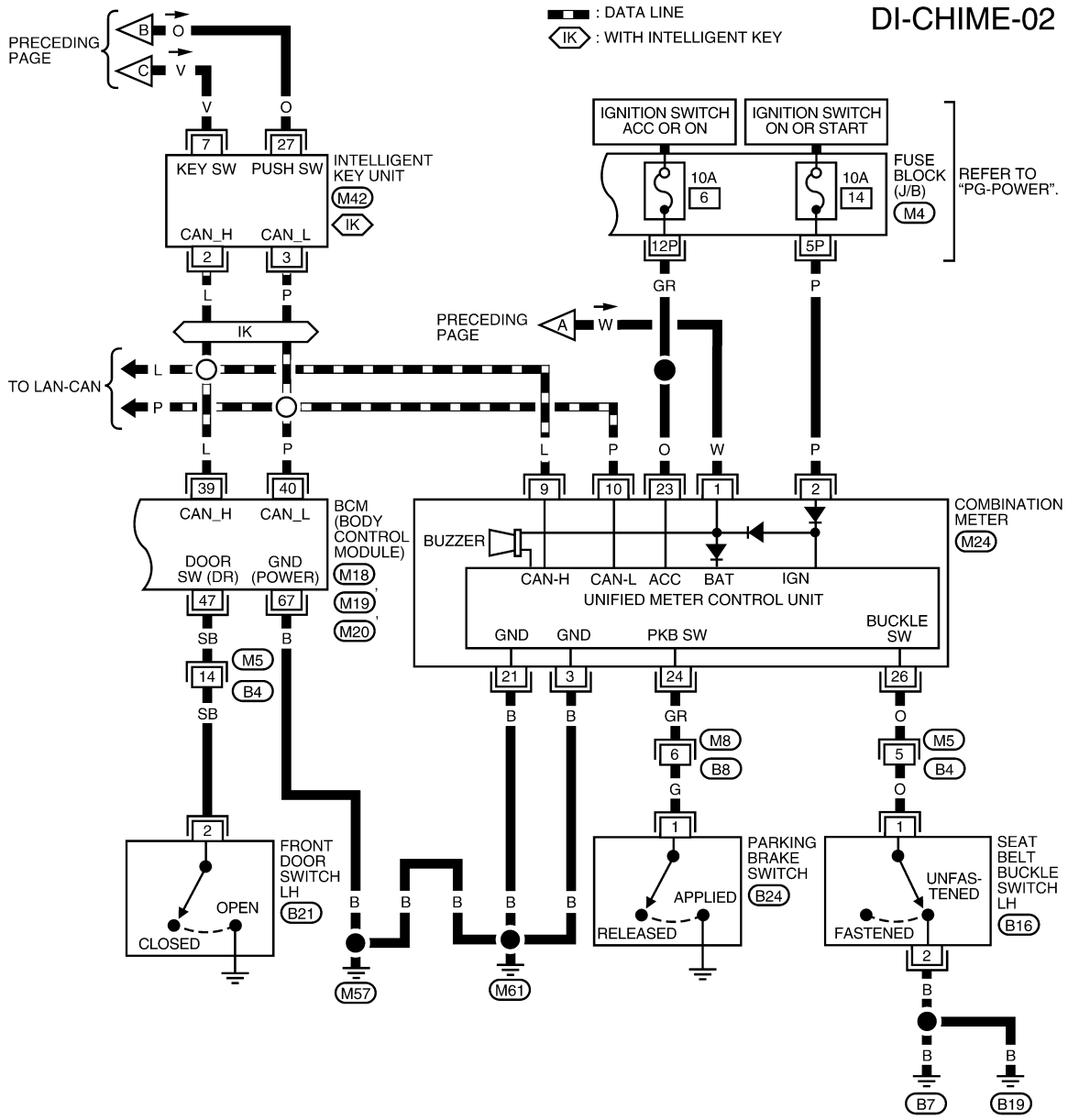

ABNWA0274GE

## Terminal and Reference Value for BCM

INFOID:000000004407654

Refer to [BCS-11, "Terminal and Reference Value for BCM"](#).

## CONSULT-III Function (BCM)

INFOID:000000004407655

CONSULT-III can display each diagnostic item using the diagnostic test modes shown following.

## WARNING CHIME

### < SERVICE INFORMATION >

BCM diagnostic test item	Diagnostic mode	Description
Inspection by part	WORK SUPPORT	Supports inspections and adjustments. Commands are transmitted to the BCM for setting the status suitable for required operation, input/output signals are received from the BCM and received data is displayed.
	DATA MONITOR	Displays BCM input/output data in real time.
	ACTIVE TEST	Operation of electrical loads can be checked by sending drive signal to them.
	SELF-DIAG RESULTS	Displays BCM self-diagnosis results.
	CAN DIAG SUPPORT MNTR	The result of transmit/receive diagnosis of CAN communication can be read.
	ECU PART NUMBER	BCM part number can be read.
	CONFIGURATION	Performs BCM configuration read/write functions.

### DATA MONITOR

#### Display Item List

Monitored item	ALL SIGNALS	SELECTION FROM MENU	Contents
IGN ON SW	X	X	Indicates [ON/OFF] condition of ignition switch.
KEY ON SW	X	X	Indicates [ON/OFF] condition of key switch.
DOOR SW-DR	X	X	Indicates [ON/OFF] condition of front door switch LH.
LIGHT SW 1ST	X	X	Indicates [ON/OFF] condition of lighting switch.
BUCKLE SW	X	X	Indicates [ON/OFF] condition of seat belt buckle switch LH.

### ACTIVE TEST

#### Display Item List

Test item	Malfunction is detected when...
IGN KEY WARN ALM	This test is able to check key warning chime operation.
LIGHT WARN ALM	This test is able to check light warning chime operation.
SEAT BELT WARN TEST	This test is able to check seat belt warning chime operation.

### SELF-DIAG RESULTS

#### Display Item List

Display item [Code]	Malfunction is detected when...
CAN communication [U1000]	Malfunction is detected in CAN communication.

#### NOTE:

If "CAN communication [U1000]" is indicated, go to "LAN system". Refer to [LAN-47, "Diagnosis Procedure"](#).

### Trouble Diagnosis

INFOID:000000004407656

#### HOW TO PERFORM TROUBLE DIAGNOSIS

1. Confirm the symptom and customer complaint.
2. Understand the outline of system. Refer to [DI-49, "System Description"](#).
3. Perform the preliminary inspection. Refer to "PRELIMINARY INSPECTION".
4. According to symptom chart, repair or replace the cause of the malfunction. Refer to "SYMPTOM CHART".
5. Does warning chime system operate normally? If it operates normally, GO TO 6. If not, GO TO 4.
6. Inspection End.

#### PRELIMINARY INSPECTION

# WARNING CHIME

## < SERVICE INFORMATION >

### 1.CHECK BCM

Perform self-diagnosis of BCM. Refer to [DI-53, "CONSULT-III Function \(BCM\)".](#)

#### Self-diagnostic results content

No malfunction detected>> GO TO 2.

Malfunction detected>> Check applicable parts, and repair or replace corresponding parts.

### 2.CHECK COMBINATION METER

Perform self-diagnosis of combination meter. Refer to [DI-14, "CONSULT-III Function \(METER/M&A\)".](#)

#### Self-diagnostic results content

No malfunction detected>> Inspection End.

Malfunction detected>> Check applicable parts, and repair or replace corresponding parts.

## SYMPTOM CHART

Symptom		Diagnoses/Service procedure
All warning chime systems do not activate.		Perform <a href="#">DI-55, "Combination Meter Buzzer Circuit Inspection"</a> . If above check is OK, replace BCM. Refer to <a href="#">BCS-17, "Removal and Installation of BCM"</a> .
Key warning chime does not activate.	Without Intelligent Key.	Perform <a href="#">DI-57, "Key Switch Signal Inspection (Without Intelligent Key)"</a> . If above check is OK, replace BCM. Refer to <a href="#">BCS-17, "Removal and Installation of BCM"</a> .
	With Intelligent Key, when mechanical key is used.	Perform <a href="#">DI-58, "Key Switch and Ignition Knob Switch Signal Inspection (With Intelligent Key, When Mechanical Key Is Used)"</a> . If above check is OK, replace BCM. Refer to <a href="#">BCS-17, "Removal and Installation of BCM"</a> .
	With Intelligent Key, when Intelligent Key is carried with the driver.	Refer to <a href="#">BL-99, "Trouble Diagnosis Symptom Chart"</a> .
Light warning chime does not activate.		Perform <a href="#">DI-60, "Lighting Switch Signal Inspection"</a> . If above check is OK, replace BCM. Refer to <a href="#">BCS-17, "Removal and Installation of BCM"</a> .
Seat belt warning chime does not activate		Perform <a href="#">DI-60, "Lighting Switch Signal Inspection"</a> . If above check is OK, replace BCM. Refer to <a href="#">BCS-17, "Removal and Installation of BCM"</a> .
Parking brake warning chime does not activate		Perform the following inspections <ul style="list-style-type: none"><li>• <a href="#">DI-61, "Parking Brake Switch Signal Inspection"</a></li><li>• <a href="#">DI-17, "Vehicle Speed Signal Inspection"</a></li></ul>

## Combination Meter Buzzer Circuit Inspection

INFOID:000000004407657

### 1.CHECK CHIME OPERATION

1. Select "BUZZER" of "BCM" on CONSULT-III.
2. Perform "LIGHT WARN ALM" or "IGN KEY WARN ALM" of "ACTIVE TEST".

#### Does chime sound?

YES >> Combination meter buzzer circuit is OK. Return to [DI-54, "Trouble Diagnosis"](#).

NO >> GO TO 2.

### 2.CHECK COMBINATION METER INPUT SIGNAL

1. Select "METER/M&A" on CONSULT-III.
2. Turn on hazard switch or lighting switch while monitoring "BUZZER" of "DATA MONITOR" and check operation status.

**"BUZZER"**

**While hazard switch or lighting switch is ON : ON and OFF repeatedly**

**Except above : OFF**

# WARNING CHIME

## < SERVICE INFORMATION >

### OK or NG

- OK >> Check battery power supply circuit of combination meter. If OK, replace combination meter. Refer to [IP-12. "Removal and Installation"](#).
- NG >> Replace BCM. Refer to [BCS-17. "Removal and Installation of BCM"](#).

## Front Door Switch LH Signal Inspection

INFOID:000000004407658

### 1. CHECK BCM INPUT SIGNAL

#### With CONSULT-III

1. Select "BCM".
2. With "DATA MONITOR" of "BUZZER", confirm "DOOR SW-DR" when the driver's door is operated.

#### "DOOR SW-DR"

- When driver's door is opened : ON
- When driver's door is closed : OFF

#### Without CONSULT-III

Check voltage between BCM harness connector and ground.

Terminals			Condition	Voltage (Approx.)
(+)		(-)		
BCM connector	Terminal			
M19	47	Ground	Driver's door is opened	0
			Driver's door is closed	Battery voltage

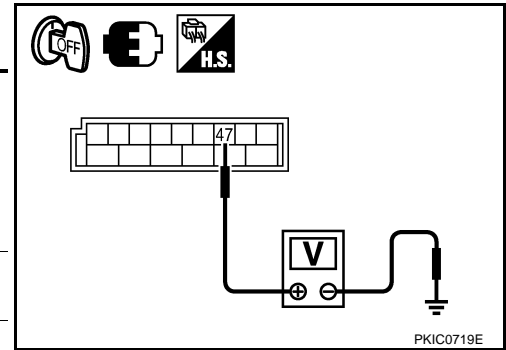

### OK or NG

- OK >> Front door switch LH signal is OK. Return to [DI-54. "Trouble Diagnosis"](#).
- NG >> GO TO 2.

### 2. CHECK FRONT DOOR SWITCH LH CIRCUIT

1. Turn ignition switch OFF.
2. Disconnect BCM connector and front door switch LH connector.
3. Check continuity between BCM harness connector (A) and front door switch LH harness connector (B).

A		B		Continuity
Connector	Terminal	Connector	Terminal	
M19	47	B21	2	Yes

4. Check continuity between BCM harness connector (A) and ground.

A		Ground	Continuity
Connector	Terminal		
M19	47		No

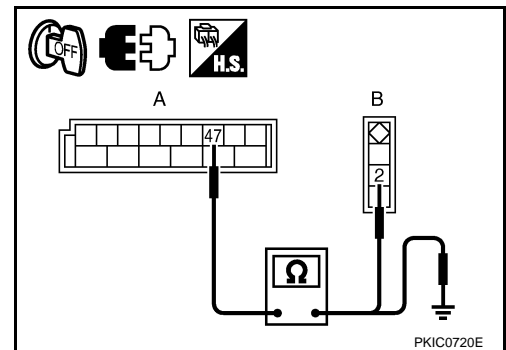

### OK or NG

- OK >> GO TO 3.
- NG >> Repair harness or connector.

### 3. CHECK FRONT DOOR SWITCH LH

Check front door switch LH. Refer to [DI-62. "Electrical Component Inspection"](#).



# WARNING CHIME

## < SERVICE INFORMATION >

### OK or NG

- OK >> Replace BCM. Refer to [BCS-17, "Removal and Installation of BCM"](#).
- NG >> Replace front door switch LH.

## Key Switch Signal Inspection (Without Intelligent Key)

INFOID:000000004407659

### 1. CHECK FUSE

Check if the key switch 10A fuse [No. 19, located in the fuse block (J/B)] is blown.

#### OK or NG

- OK >> GO TO 2.
- NG >> Be sure to repair the cause of malfunction before installing new fuse. Refer to [PG-3](#).

### 2. CHECK BCM INPUT SIGNAL

#### Ⓜ With CONSULT-III

1. Select "BCM".
2. With "DATA MONITOR" of "BUZZER", confirm "KEY ON SW" when the key is operated.

#### "KEY ON SW"

When key is inserted into ignition key cylinder : ON

When key is removed from ignition key cylinder : OFF

#### ⓧ Without CONSULT-III

Check voltage between BCM harness connector and ground.

Terminals		(-)	Condition	Voltage (Approx.)
(+)				
BCM connector	Terminal			
M18	37	Ground	Key is inserted	Battery voltage
			Key is removed	0 V

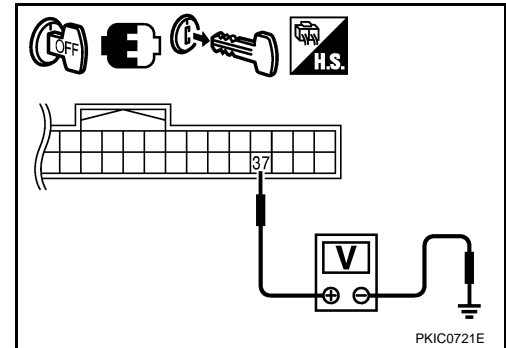

#### OK or NG

- OK >> Key switch signal is OK. Return to [DI-54, "Trouble Diagnosis"](#).
- NG >> GO TO 3.

### 3. CHECK KEY SWITCH

1. Turn ignition switch OFF.
2. Disconnect key switch connector.
3. Check continuity between key switch terminals 1 and 2.

Terminals		Condition	Continuity
1	2	When key is inserted into ignition key cylinder	Yes
		When key is removed from ignition key cylinder	No

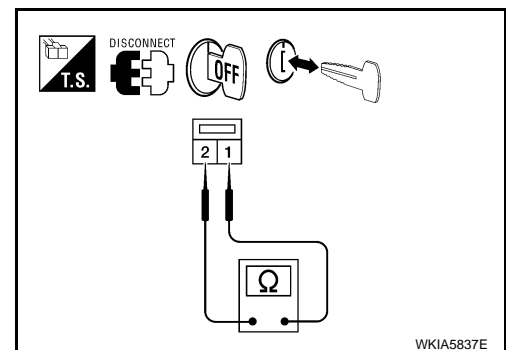

#### OK or NG

- OK >> GO TO 4.
- NG >> Replace key switch.

### 4. CHECK KEY SWITCH CIRCUIT

1. Disconnect BCM connector.

# WARNING CHIME

## < SERVICE INFORMATION >

2. Check continuity between BCM harness connector (A) and key switch harness connector (B).

A		B		Continuity
Connector	Terminal	Connector	Terminal	
M18	37	M50	1	Yes

3. Check continuity between BCM harness connector (A) and ground.

A		Ground	Continuity
Connector	Terminal		
M18	37		No

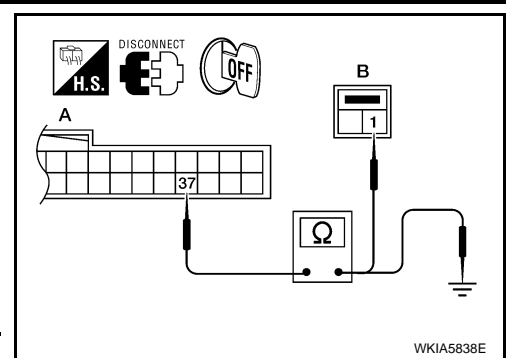

### OK or NG

- OK >> GO TO 5.
- NG >> Repair harness or connector.

## 5. CHECK KEY SWITCH POWER SUPPLY CIRCUIT

Check voltage between key switch harness connector and ground.

Terminals			Voltage (Approx.)
(+)		(-)	
Key switch connector	Terminal		
M50	2	Ground	Battery voltage

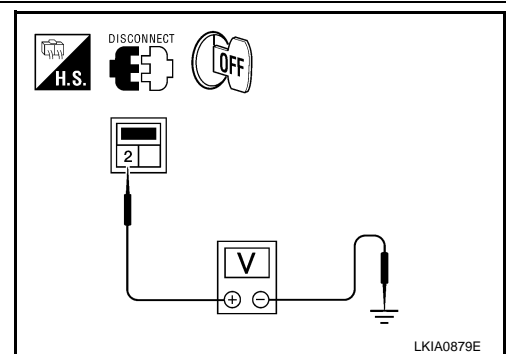

### OK or NG

- OK >> Replace BCM. Refer to [BCS-17, "Removal and Installation of BCM"](#).
- NG >> Repair harness or connector.

Key Switch and Ignition Knob Switch Signal Inspection (With Intelligent Key, When Mechanical Key Is Used)

INFOID:000000004407660

## 1. CHECK FUSE

Check if the key switch and ignition knob switch 10A fuse [No. 9, located in the fuse block (J/B)] is blown.

### OK or NG

- OK >> GO TO 2.
- NG >> Be sure to repair the cause of malfunction before installing new fuse. Refer to [PG-3](#).

## 2. CHECK BCM INPUT SIGNAL

### Ⓜ With CONSULT-III

1. Select "BCM".
2. With "DATA MONITOR" of "BUZZER", confirm "KEY ON SW" when the key is operated.

#### "KEY ON SW"

When key is inserted into ignition key cylinder : ON

When key is removed from ignition key cylinder : OFF

### ⓧ Without CONSULT-III

# WARNING CHIME

## < SERVICE INFORMATION >

Check voltage between BCM harness connector and ground.

Terminals		(-)	Condition	Voltage (Approx.)
(+)				
BCM connector	Terminal			
M18	37	Ground	Key is inserted	Battery voltage
			Key is removed	0

**OK or NG**

OK >> Key switch and ignition knob switch signal is OK. Return to [DI-54, "Trouble Diagnosis"](#).

NG >> GO TO 3.

### 3.CHECK KEY SWITCH

1. Turn ignition switch OFF.
2. Disconnect key switch and ignition knob switch connector.
3. Check continuity between key switch and ignition knob switch terminals 1 and 2.

Terminals		Condition	Continuity
1	2	When key is inserted into ignition key cylinder	Yes
		When key is removed from ignition key cylinder	No

**OK or NG**

OK >> GO TO 4.

NG >> Replace key switch and ignition knob switch.

### 4.CHECK KEY SWITCH CIRCUIT

1. Disconnect BCM connector.
2. Check continuity between BCM harness connector (A) and key switch and ignition knob switch harness connector (B).

A		B		Continuity
Connector	Terminal	Connector	Terminal	
M18	37	M49	1	Yes

3. Check continuity between BCM harness connector (A) and ground.

A		Ground	Continuity
Connector	Terminal		
M18	37		No

**OK or NG**

OK >> GO TO 5.

NG >> Repair harness or connector.

### 5.CHECK KEY SWITCH POWER SUPPLY CIRCUIT

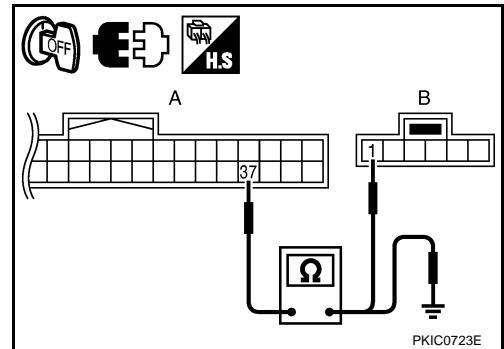
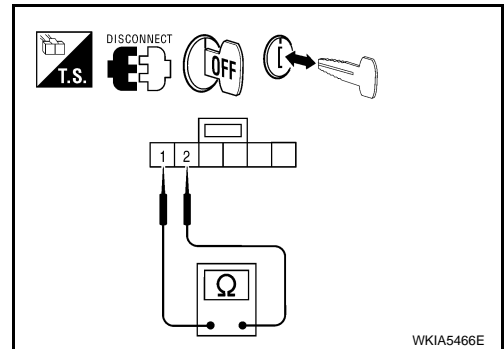
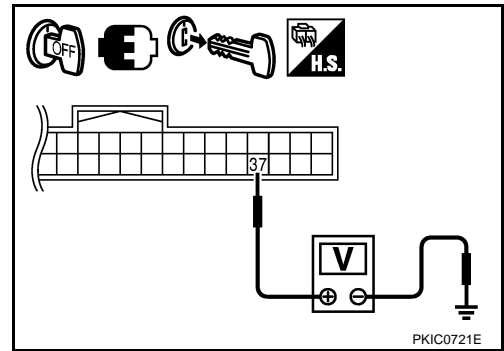

A  
B  
C  
D  
E  
F  
G  
H  
I  
J  
K  
L  
M  
N  
O  
P

DI

# WARNING CHIME

## < SERVICE INFORMATION >

Check voltage between key switch and ignition knob switch harness connector and ground.

Terminals			Voltage (Approx.)
(+)		(-)	
Key switch and ignition knob switch connector	Terminal		
M49	2	Ground	Battery voltage

### OK or NG

OK >> Replace BCM. Refer to [BCS-17, "Removal and Installation of BCM"](#).

NG >> Repair harness or connector.

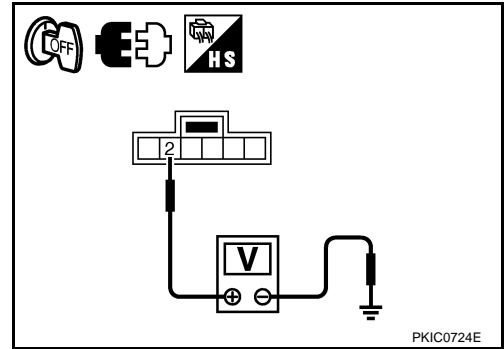

PKIC0724E

INFOID:000000004407661

## Lighting Switch Signal Inspection

### 1. CHECK BCM INPUT SIGNAL

1. Select "BCM" on CONSULT-III.
2. With "DATA MONITOR" of "BUZZER", confirm "LIGHT SW 1ST" when the lighting switch is operated.

#### "LIGHT SW 1ST"

Lighting switch (1st position) : ON

Lighting switch (OFF) : OFF

### OK or NG

OK >> Lighting switch signal is OK. Return to [DI-54, "Trouble Diagnosis"](#).

NG >> Check the lighting switch. Refer to [LT-60, "Combination Switch Inspection"](#).

## Seat Belt Buckle Switch LH Signal Inspection

INFOID:000000004407662

### 1. CHECK SEAT BELT BUCKLE SWITCH LH SIGNAL INPUT (BCM)

1. Select "BCM" on CONSULT-III.
2. With "DATA MONITOR" of "BUZZER", confirm "BUCKLE SW" when the seat belt buckle switch LH is operated.

#### "BUCKLE SW"

When seat belt is fastened : OFF

When seat belt is unfastened : ON

### OK or NG

OK >> Inspection End.

NG >> GO TO 2.

### 2. CHECK SEAT BELT BUCKLE SWITCH LH SIGNAL INPUT (COMBINATION METER)

1. Turn ignition switch ON.
2. Check voltage between combination meter harness connector M24 terminal 26 and ground.

Terminals			Condition	Voltage (Approx.)
(+)		(-)		
Combination meter connector	Terminal			
M24	26	Ground	Seat belt fastened	Battery voltage
			Seat belt unfastened	0

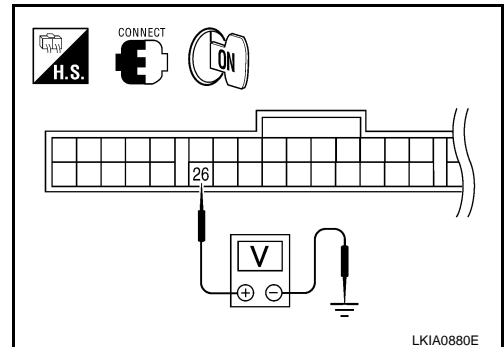

LKIA0880E

### OK or NG

# WARNING CHIME

## < SERVICE INFORMATION >

- OK >> Replace combination meter. Refer to [IP-12. "Removal and Installation"](#).  
 NG >> GO TO 3.

### 3. CHECK SEAT BELT BUCKLE SWITCH LH CIRCUIT

- Turn ignition switch OFF.
- Disconnect combination meter connector and seat belt buckle switch LH connector.
- Check continuity between combination meter harness connector (A) and seat belt buckle switch LH harness connector (B).

A		B		Continuity
Connector	Terminal	Connector	Terminal	
M24	26	B16	1	Yes

- Check continuity between combination meter harness connector (A) and ground.

A		Ground	Continuity
Connector	Terminal		
M24	26		No

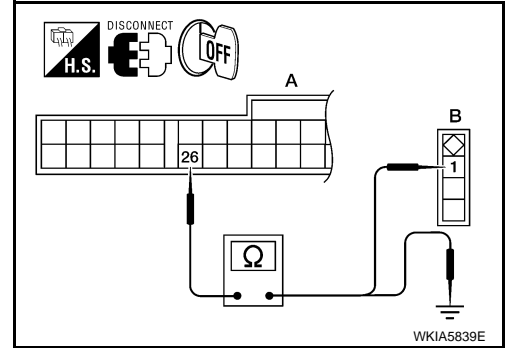

#### OK or NG

- OK >> GO TO 4.  
 NG >> Repair harness or connector.

### 4. CHECK SEAT BELT BUCKLE SWITCH LH

Check seat belt buckle switch LH. Refer to [DI-62. "Electrical Component Inspection"](#).

#### OK or NG

- OK >> Check seat belt buckle switch LH ground circuit.  
 NG >> Replace seat belt buckle switch LH.

## Parking Brake Switch Signal Inspection

INFOID:000000004407663

### 1. CHECK PARKING BRAKE SWITCH SIGNAL INPUT (COMBINATION METER)

- Turn ignition switch ON.
- Check voltage between combination meter harness connector M24 terminal 24 and ground.

Terminals			Condition	Voltage (Approx.)
(+)		(-)		
Combination meter connector	Terminal			
M24	24	Ground	Parking brake released	Battery voltage
			Parking brake applied	0

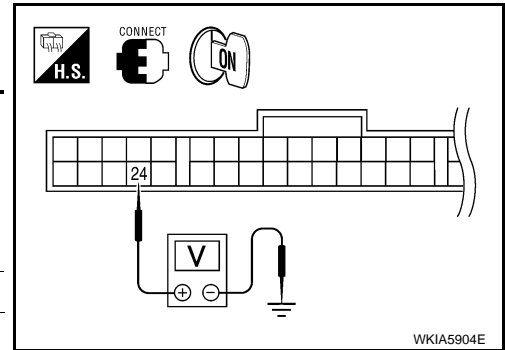

#### OK or NG

- OK >> Replace combination meter. Refer to [IP-12. "Removal and Installation"](#).  
 NG >> GO TO 2.

### 2. CHECK PARKING BRAKE SWITCH CIRCUIT

- Turn ignition switch OFF.
- Disconnect combination meter connector and parking brake switch connector.

# WARNING CHIME

## < SERVICE INFORMATION >

3. Check continuity between combination meter harness connector (A) and parking brake switch harness connector (B).

A		B		Continuity
Connector	Terminal	Connector	Terminal	
M24	24	B24	1	Yes

4. Check continuity between combination meter harness connector (A) and ground.

A		Ground	Continuity
Connector	Terminal		
M24	24		No

### OK or NG

OK >> GO TO 3.

NG >> Repair harness or connector.

## 3. CHECK PARKING BRAKE SWITCH

Check parking brake switch. Refer to [DI-62. "Electrical Component Inspection"](#).

### OK or NG

OK >> Check parking brake switch case ground.

NG >> Replace parking brake switch.

## Electrical Component Inspection

INFOID:000000004407664

### FRONT DOOR SWITCH LH

Check continuity between terminal 2 and door switch case ground.

Terminal		Condition	Continuity
2	Door switch case ground	When door switch is released.	Yes
		When door switch is pushed.	No

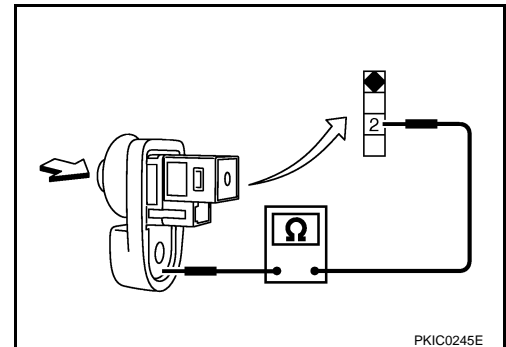

### SEAT BELT BUCKLE SWITCH LH

Check continuity between terminals 1 and 2.

Terminal		Condition	Continuity
1	2	When seat belt LH is fastened.	No
		When seat belt LH is unfastened.	Yes

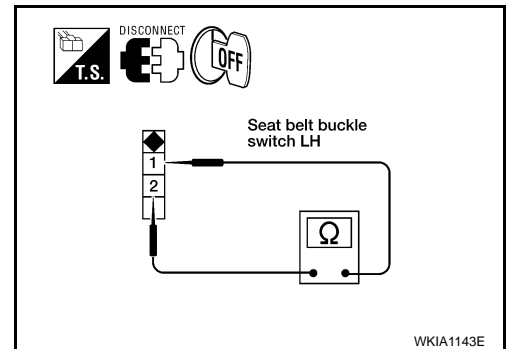

## PARKING BRAKE SWITCH

# WARNING CHIME

## < SERVICE INFORMATION >

Check continuity between terminal 1 and parking brake switch case ground.

Terminal		Condition	Continuity
1	Parking brake switch case ground	When parking brake is applied.	Yes
		When parking brake is released.	No

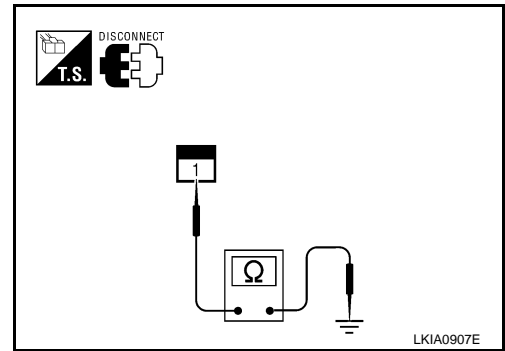

- A
- B
- C
- D
- E
- F
- G
- H
- I
- J
- DI
- L
- M
- N
- O
- P