

SECTION **CVT**
 CVT

CONTENTS

SERVICE INFORMATION	5	ON BOARD DIAGNOSTIC (OBD) SYSTEM	25
INDEX FOR DTC	5	Introduction	25
Alphabetical Index	5	OBD-II Function for CVT System	25
DTC No. Index	5	One or Two Trip Detection Logic of OBD-II	25
PRECAUTIONS	7	OBD-II Diagnostic Trouble Code (DTC)	25
Precaution for Supplemental Restraint System (SRS) "AIR BAG" and "SEAT BELT PRE-TENSIONER"	7	Malfunction Indicator Lamp (MIL)	26
Precaution Necessary for Steering Wheel Rotation After Battery Disconnect	7	TROUBLE DIAGNOSIS	28
Precaution for On Board Diagnosis (OBD) System of CVT and Engine	8	DTC Inspection Priority Chart	28
Service After Replacing TCM and Transaxle Assembly	8	Fail-Safe	28
Removal and Installation Procedure for CVT Unit Connector	9	How to Perform Trouble Diagnosis for Quick and Accurate Repair	29
Precaution	10	CVT Electrical Parts Location	34
Service Notice or Precaution	12	Circuit Diagram	35
ATFTEMP COUNT Conversion Table	12	Inspections before Trouble Diagnosis	36
PREPARATION	14	Road Test	39
Special Service Tool	14	Check before Engine Is Started	40
Commercial Service Tool	14	Check at Idle	40
CVT FLUID	15	Cruise Test	41
Checking CVT Fluid	15	Vehicle Speed When Shifting Gears	44
Changing CVT Fluid	16	TCM Input/Output Signal Reference Value	45
CVT SYSTEM	17	CONSULT-III Function (TRANSMISSION)	47
Cross-Sectional View - RE0F10A	17	Diagnosis Procedure without CONSULT-III	54
Control System	18	DTC U1000 CAN COMMUNICATION LINE	55
Hydraulic Control System	19	Description	55
TCM Function	19	On Board Diagnosis Logic	55
CAN Communication	20	Possible Cause	55
Input/Output Signal of TCM	20	DTC Confirmation Procedure	55
Line Pressure and Secondary Pressure Control	21	Wiring Diagram - CVT - CAN	56
Shift Control	21	Diagnosis Procedure	57
Lock-up and Select Control	23	DTC U1010 TRANSMISSION CONTROL MODULE (CAN)	58
Control Valve	24	Description	58
		On Board Diagnosis Logic	58
		Possible Cause	58
		DTC Confirmation Procedure	58
		Diagnosis Procedure	58
		DTC P0703 STOP LAMP SWITCH CIRCUIT ...	59

Description	59	On Board Diagnosis Logic	83
CONSULT-III Reference Value	59	Possible Cause	83
On Board Diagnosis Logic	59	DTC Confirmation Procedure	83
Possible Cause	59	Diagnosis Procedure	83
DTC Confirmation Procedure	59		
Diagnosis Procedure	59		
DTC P0705 PARK/NEUTRAL POSITION SWITCH	61	DTC P0740 TORQUE CONVERTER CLUTCH SOLENOID VALVE	84
Description	61	Description	84
CONSULT-III Reference Value	61	CONSULT-III Reference Value	84
On Board Diagnosis Logic	61	On Board Diagnosis Logic	84
Possible Cause	61	Possible Cause	84
DTC Confirmation Procedure	61	DTC Confirmation Procedure	84
Wiring Diagram - CVT - PNP/SW	62	Wiring Diagram - CVT - TCV	85
Diagnosis Procedure	63	Diagnosis Procedure	86
Component Inspection	64	Component Inspection	87
DTC P0710 CVT FLUID TEMPERATURE SENSOR CIRCUIT	66	DTC P0744 A/T TCC S/V FUNCTION (LOCK-UP)	89
Description	66	Description	89
CONSULT-III Reference Value	66	CONSULT-III Reference Value	89
On Board Diagnosis Logic	66	On Board Diagnosis Logic	89
Possible Cause	66	Possible Cause	89
DTC Confirmation Procedure	66	DTC Confirmation Procedure	89
Wiring Diagram - CVT - FTS	67	Diagnosis Procedure	89
Diagnosis Procedure	68		
Component Inspection	69		
DTC P0715 INPUT SPEED SENSOR CIRCUIT (PRI SPEED SENSOR)	71	DTC P0745 LINE PRESSURE SOLENOID VALVE	91
Description	71	Description	91
CONSULT-III Reference Value	71	CONSULT-III Reference Value	91
On Board Diagnosis Logic	71	On Board Diagnosis Logic	91
Possible Cause	71	Possible Cause	91
DTC Confirmation Procedure	71	DTC Confirmation Procedure	91
Wiring Diagram - CVT - PRSCVT	72	Wiring Diagram - CVT - LPSV	92
Diagnosis Procedure	73	Diagnosis Procedure	93
		Component Inspection	94
DTC P0720 VEHICLE SPEED SENSOR CVT (SECONDARY SPEED SENSOR)	76	DTC P0746 PRESSURE CONTROL SOLENOID A PERFORMANCE (LINE PRESSURE SOLENOID VALVE)	96
Description	76	Description	96
CONSULT-III Reference Value	76	CONSULT-III Reference Value	96
On Board Diagnosis Logic	76	On Board Diagnosis Logic	96
Possible Cause	76	Possible Cause	96
DTC Confirmation Procedure	76	DTC Confirmation Procedure	96
Wiring Diagram - CVT - SESCOVT	77	Diagnosis Procedure	96
Diagnosis Procedure	78		
DTC P0725 ENGINE SPEED SIGNAL	81	DTC P0776 PRESSURE CONTROL SOLENOID B PERFORMANCE (SEC PRESSURE SOLENOID VALVE)	98
Description	81	Description	98
CONSULT-III Reference Value	81	CONSULT-III Reference Value	98
On Board Diagnosis Logic	81	On Board Diagnosis Logic	98
Possible Cause	81	Possible Cause	98
DTC Confirmation Procedure	81	DTC Confirmation Procedure	98
Diagnosis Procedure	81	Diagnosis Procedure	98
DTC P0730 BELT DAMAGE	83	DTC P0778 PRESSURE CONTROL SOLENOID B ELECTRICAL (SEC PRESSURE SOLENOID VALVE)	100
Description	83		
CONSULT-III Reference Value	83		

Description	100	Description	122	
CONSULT-III Reference Value	100	CONSULT-III Reference Value	122	A
On Board Diagnosis Logic	100	On Board Diagnosis Logic	122	
Possible Cause	100	Possible Cause	122	
DTC Confirmation Procedure	100	DTC Confirmation Procedure	122	B
Wiring Diagram - CVT - SECPSV	101	Diagnosis Procedure	122	
Diagnosis Procedure	102			
Component Inspection	103			
DTC P0826 MANUAL MODE SWITCH CIRCUIT	105	DTC P1722 ESTM VEHICLE SPEED SIGNAL. 124		CVT
Description	105	Description	124	
CONSULT-III Reference Value in Data Monitor Mode	105	CONSULT-III Reference Value	124	
On Board Diagnosis Logic	105	On Board Diagnosis Logic	124	D
Possible Cause	105	Possible Cause	124	
DTC Confirmation Procedure	105	DTC Confirmation Procedure	124	
Wiring Diagram - CVT - MMSW	106	Diagnosis Procedure	124	
Diagnosis Procedure	107			
Component Inspection	109	DTC P1723 CVT SPEED SENSOR FUNCTION	126	E
		Description	126	
DTC P0840 TRANSMISSION FLUID PRESSURE SENSOR A CIRCUIT (SEC PRESSURE SENSOR)	110	On Board Diagnosis Logic	126	F
Description	110	Possible Cause	126	
CONSULT-III Reference Value	110	DTC Confirmation Procedure	126	
On Board Diagnosis Logic	110	Diagnosis Procedure	126	G
Possible Cause	110			
DTC Confirmation Procedure	110	DTC P1726 ELECTRIC THROTTLE CONTROL SYSTEM	128	H
Wiring Diagram - CVT - SECPS	111	Description	128	
Diagnosis Procedure	112	On Board Diagnosis Logic	128	
		Possible Cause	128	
DTC P0841 PRESSURE SENSOR FUNCTION	114	DTC Confirmation Procedure	128	I
Description	114	Diagnosis Procedure	128	
CONSULT-III Reference Value	114			
On Board Diagnosis Logic	114	DTC P1740 LOCK-UP SELECT SOLENOID VALVE CIRCUIT	129	J
Possible Cause	114	Description	129	
DTC Confirmation Procedure	114	CONSULT-III Reference Value	129	
Diagnosis Procedure	114	On Board Diagnosis Logic	129	K
		Possible Cause	129	
DTC P0868 SECONDARY PRESSURE DOWN	116	DTC Confirmation Procedure	129	
Description	116	Wiring Diagram - CVT - L/USSV	130	L
CONSULT-III Reference Value	116	Diagnosis Procedure	131	
On Board Diagnosis Logic	116	Component Inspection	132	
Possible Cause	116			
DTC Confirmation Procedure	116	DTC P1745 LINE PRESSURE CONTROL	134	M
Diagnosis Procedure	116	Description	134	
		On Board Diagnosis Logic	134	
DTC P1701 TRANSMISSION CONTROL MODULE (POWER SUPPLY)	118	Possible Cause	134	N
Description	118	DTC Confirmation Procedure	134	
On Board Diagnosis Logic	118	Diagnosis Procedure	134	
Possible Cause	118			
DTC Confirmation Procedure	118	DTC P1777 STEP MOTOR - CIRCUIT	135	O
Wiring Diagram - CVT - POWER	119	Description	135	
Diagnosis Procedure	120	CONSULT-III Reference Value	135	
		On Board Diagnosis Logic	135	P
DTC P1705 THROTTLE POSITION SENSOR. 122		Possible Cause	135	
		DTC Confirmation Procedure	135	
		Wiring Diagram - CVT - STM	136	
		Diagnosis Procedure	137	
		Component Inspection	138	
		DTC P1778 STEP MOTOR - FUNCTION	139	

Description	139	SHIFT CONTROL SYSTEM	168
CONSULT-III Reference Value	139	Removal and Installation	168
On Board Diagnosis Logic	139	Selector Lever Knob Removal and Installation	169
Possible Cause	139	Adjustment of CVT Position	170
DTC Confirmation Procedure	139	Checking of CVT Position	170
Diagnosis Procedure	140	Adjustment of PNP switch	171
OVERDRIVE CONTROL SWITCH	141	KEY INTERLOCK CABLE	172
Description	141	Removal and Installation	172
CONSULT-III Reference Value	141	ON-VEHICLE SERVICE	175
Wiring Diagram - CVT - ODSW	142	Oil Pan	175
Diagnosis Procedure	143	Control Valve	176
Component Inspection	144	Park/Neutral Position (PNP) Switch	182
SHIFT POSITION INDICATOR CIRCUIT	146	Primary Speed Sensor	182
Description	146	Secondary Speed Sensor	183
CONSULT-III Reference Value	146	Differential Side Oil Seal	184
Diagnosis Procedure	146	Oil Pump Fitting Bolt	184
TROUBLE DIAGNOSIS FOR SYMPTOMS	147	AIR BREATHER HOSE	186
Wiring Diagram - CVT - NONDTC	147	Removal and Installation (MR20DE)	186
O/D OFF Indicator Lamp Does Not Come On	150	Removal and Installation (QR25DE)	187
Engine Cannot Be Started in "P" or "N" Position ..	152	CVT FLUID COOLER SYSTEM	188
In "P" Position, Vehicle Moves Forward or Back-		CVT Fluid Cooler Removal and Installation	
ward When Pushed	152	(MR20DE)	188
In "N" Position, Vehicle Moves	153	CVT Fluid Cooler Removal and Installation	
Large Shock "N" Æ "R" Position	153	(QR25DE)	188
Vehicle Does Not Creep Backward in "R" Position.	154	TRANSAXLE ASSEMBLY	190
Vehicle Does Not Creep Forward in "D" or "L" Po-		Removal and Installation (MR20DE)	190
sition	155	Removal and Installation (QR25DE)	192
Vehicle Speed Does Not Change in "L" Position ..	156	REPAIR FOR COMPONENT PARTS	195
Vehicle Speed Does Not Change in overdrive-off		Torque Converter and Converter Housing Oil Seal	
mode	157		195
Vehicle Speed Does Not Change in "D" Position ..	158	SERVICE DATA AND SPECIFICATIONS	
Cannot Be Changed to Manual Mode	158	(SDS)	196
CVT Does Not Shift in Manual Mode	159	General Specification	196
Vehicle Does Not Decelerate by Engine Brake	160	Vehicle Speed When Shifting Gears	196
TRANSMISSION CONTROL MODULE	162	Stall Speed	196
Removal and Installation	162	Line Pressure	197
CVT SHIFT LOCK SYSTEM	164	Solenoid Valves	197
Description	164	CVT Fluid Temperature Sensor	197
Shift Lock System Electrical Parts Location	164	Primary Speed Sensor	197
Wiring Diagram - CVT - SHIFT	165	Secondary Speed Sensor	197
Diagnosis Procedure	165	Removal and Installation	197

INDEX FOR DTC

< SERVICE INFORMATION >

SERVICE INFORMATION

INDEX FOR DTC

Alphabetical Index

INFOID:000000004407038

NOTE:

If DTC “U1000 CAN COMM CIRCUIT” is displayed with other DTCs, first perform the trouble diagnosis for “DTC U1000 CAN COMMUNICATION LINE”. Refer to [CVT-55](#).

Items (CONSULT-III screen terms)	DTC*1		Reference
	MIL *2, “ENGINE” with CONSULT-III or GST	CONSULT-III only “TRANSMISSION”	
A/T TCC S/V FNCTN	P0744	P0744	CVT-89
ATF TEMP SEN/CIRC	P0710	P0710	CVT-66
BELT DAMG	—	P0730	CVT-83
BRAKE SW/CIRC	—	P0703	CVT-59
CAN COMM CIRCUIT	U1000	U1000	CVT-55
TRANSMISSION CONTROL UNIT (CAN)	U1010	U1010	CVT-58
CVT SPD SEN/FNCTN	—	P1723	CVT-126
ENGINE SPEED SIG	—	P0725	CVT-81
ELEC TH CONTROL	—	P1726	CVT-128
ESTM VEH SPD SIG*3	—	P1722	CVT-124
INPUT SPD SEN/CIRC	P0715	P0715	CVT-71
L/PRESS CONTROL	—	P1745	CVT-134
L/PRESS SOL/CIRC	P0745	P0745	CVT-91
LU-SLCT SOL/CIRC	P1740	P1740	CVT-129
MANUAL MODE SWITCH	—	P0826	CVT-105
PNP SW/CIRC	P0705	P0705	CVT-61
PRESS SEN/FNCTN	—	P0841	CVT-114
PRS CNT SOL/A FCTN	P0746	P0746	CVT-96
PRS CNT SOL/B CIRC	P0778	P0778	CVT-100
PRS CNT SOL/B FCTN	P0776	P0776	CVT-98
SEC/PRESS DOWN	—	P0868	CVT-116
STEP MOTR CIRC	P1777	P1777	CVT-135
STEP MOTR/FNC	P1778	P1778	CVT-139
TCC SOLENOID/CIRC	P0740	P0740	CVT-84
TCM-POWER SUPPLY	—	P1701	CVT-118
TP SEN/CIRC A/T	—	P1705	CVT-122
TR PRS SENS/A CIRC	P0840	P0840	CVT-110
VEH SPD SEN/CIR AT	P0720	P0720	CVT-76

*1: These numbers are prescribed by SAE J2012.

*2: Refer to [CVT-25, "Introduction"](#).

*3: Models without ABS does not indicate.

DTC No. Index

INFOID:000000004407039

NOTE:

INDEX FOR DTC

< SERVICE INFORMATION >

If DTC “U1000 CAN COMM CIRCUIT” is displayed with other DTCs, first perform the trouble diagnosis for “DTC U1000 CAN COMMUNICATION LINE”. Refer to [CVT-55](#).

DTC*1		Items (CONSULT-III screen terms)	Reference
MIL*2, “ENGINE” with CONSULT-III or GST	CONSULT-III only “TRANSMISSION”		
—	P0703	BRAKE SW/CIRC	CVT-59
P0705	P0705	PNP SW/CIRC	CVT-61
P0710	P0710	ATF TEMP SEN/CIRC	CVT-66
P0715	P0715	INPUT SPD SEN/CIRC	CVT-71
P0720	P0720	VEH SPD SEN/CIR AT	CVT-76
—	P0725	ENGINE SPEED SIG	CVT-81
—	P0730	BELT DAMG	CVT-83
P0740	P0740	TCC SOLENOID/CIRC	CVT-84
P0744	P0744	A/T TCC S/V FNCTN	CVT-89
P0745	P0745	L/PRESS SOL/CIRC	CVT-91
P0746	P0746	PRS CNT SOL/A FCTN	CVT-96
P0776	P0776	PRS CNT SOL/B FCTN	CVT-98
P0778	P0778	PRS CNT SOL/B CIRC	CVT-100
—	P0826	MANUAL MODE SWITCH	CVT-105
P0840	P0840	TR PRS SENS/A CIRC	CVT-110
—	P0841	PRESS SEN/FNCTN	CVT-114
—	P0868	SEC/PRESS DOWN	CVT-116
—	P1701	TCM-POWER SUPPLY	CVT-118
—	P1705	TP SEN/CIRC A/T	CVT-122
—	P1722	ESTM VEH SPD SIG*3	CVT-124
—	P1723	CVT SPD SEN/FNCTN	CVT-126
—	P1726	ELEC TH CONTROL	CVT-128
P1740	P1740	LU-SLCT SOL/CIRC	CVT-129
—	P1745	L/PRESS CONTROL	CVT-134
P1777	P1777	STEP MOTR CIRC	CVT-135
P1778	P1778	STEP MOTR/FNC	CVT-139
U1000	U1000	CAN COMM CIRCUIT	CVT-55
U1010	U1010	TRANSMISSION CONTROL UNIT (CAN)	CVT-58

*1: These numbers are prescribed by SAE J2012.

*2: Refer to [CVT-25, "Introduction"](#).

*3: Models without ABS does not indicate.

PRECAUTIONS

< SERVICE INFORMATION >

PRECAUTIONS

Precaution for Supplemental Restraint System (SRS) "AIR BAG" and "SEAT BELT PRE-TENSIONER"

INFOID:000000004779244

The Supplemental Restraint System such as "AIR BAG" and "SEAT BELT PRE-TENSIONER", used along with a front seat belt, helps to reduce the risk or severity of injury to the driver and front passenger for certain types of collision. This system includes seat belt switch inputs and dual stage front air bag modules. The SRS system uses the seat belt switches to determine the front air bag deployment, and may only deploy one front air bag, depending on the severity of a collision and whether the front occupants are belted or unbelted. Information necessary to service the system safely is included in the SRS and SB section of this Service Manual.

WARNING:

- To avoid rendering the SRS inoperative, which could increase the risk of personal injury or death in the event of a collision which would result in air bag inflation, all maintenance must be performed by an authorized NISSAN/INFINITI dealer.
- Improper maintenance, including incorrect removal and installation of the SRS can lead to personal injury caused by unintentional activation of the system. For removal of Spiral Cable and Air Bag Module, see the SRS section.
- Do not use electrical test equipment on any circuit related to the SRS unless instructed to in this Service Manual. SRS wiring harnesses can be identified by yellow and/or orange harnesses or harness connectors.
- When working near the Airbag Diagnosis Sensor Unit or other Airbag System sensors with the Ignition ON or engine running, DO NOT use air or electric power tools or strike near the sensor(s) with a hammer. Heavy vibration could activate the sensor(s) and deploy the air bag(s), possibly causing serious injury.
- When using air or electric power tools or hammers, always switch the Ignition OFF, disconnect the battery, and wait at least 3 minutes before performing any service.

Precaution Necessary for Steering Wheel Rotation After Battery Disconnect

INFOID:000000004407041

NOTE:

- This Procedure is applied only to models with Intelligent Key system and NVIS/IVIS (NISSAN/INFINITI VEHICLE IMMOBILIZER SYSTEM - NATS).
- Remove and install all control units after disconnecting both battery cables with the ignition knob in the "LOCK" position.
- Always use CONSULT-III to perform self-diagnosis as a part of each function inspection after finishing work. If DTC is detected, perform trouble diagnosis according to self-diagnostic results.

For models equipped with the Intelligent Key system and NVIS/IVIS, an electrically controlled steering lock mechanism is adopted on the key cylinder.

For this reason, if the battery is disconnected or if the battery is discharged, the steering wheel will lock and steering wheel rotation will become impossible.

If steering wheel rotation is required when battery power is interrupted, follow the procedure below before starting the repair operation.

OPERATION PROCEDURE

1. Connect both battery cables.

NOTE:

Supply power using jumper cables if battery is discharged.

2. Use the Intelligent Key or mechanical key to turn the ignition switch to the "ACC" position. At this time, the steering lock will be released.
3. Disconnect both battery cables. The steering lock will remain released and the steering wheel can be rotated.
4. Perform the necessary repair operation.
5. When the repair work is completed, return the ignition switch to the "LOCK" position before connecting the battery cables. (At this time, the steering lock mechanism will engage.)
6. Perform a self-diagnosis check of all control units using CONSULT-III.

PRECAUTIONS

< SERVICE INFORMATION >

Precaution for On Board Diagnosis (OBD) System of CVT and Engine

INFOID:000000004407042

The ECM has an on board diagnostic system. It will light up the malfunction indicator lamp (MIL) to warn the driver of a malfunction causing emission deterioration.

CAUTION:

- Be sure to turn the ignition switch OFF and disconnect the battery cable from the negative terminal before any repair or inspection work. The open/short circuit of related switches, sensors, solenoid valves, etc. will cause the MIL to light up.
- Be sure to connect and lock the connectors securely after work. A loose (unlocked) connector will cause the MIL to light up due to an open circuit. (Be sure the connector is free from water, grease, dirt, bent terminals, etc.)
- Be sure to route and secure the harnesses properly after work. Interference of the harness with a bracket, etc. may cause the MIL to light up due to a short circuit.
- Be sure to connect rubber tubes properly after work. A misconnected or disconnected rubber tube may cause the MIL to light up due to a malfunction of the EVAP system or fuel injection system, etc.
- Be sure to erase the unnecessary malfunction information (repairs completed) from the TCM and ECM before returning the vehicle to the customer.

Service After Replacing TCM and Transaxle Assembly

INFOID:000000004407043

SERVICE AFTER REPLACING TCM AND TRANSAXLE ASSEMBLY

Perform the applicable service in the following sheet when replacing TCM or transaxle assembly

CAUTION:

- Do not start the engine until the service is completed.
- "TCM- POWER SUPPLY [P1701]" may be indicated soon after replacing TCM or transaxle assembly (after erasing the memory at the pattern B). Restart the self-diagnosis after erasing the self-diagnosis result. Check that no error is detected.

TCM	CVT assembly	Service pattern
Replace the new unit.	Do not replace the unit.	"PATTERN A"
Do not replace the unit.	Replace either the old unit or new unit.	"PATTERN B"
Replace the old unit.	Do not replace the unit.	
	Replace either the old unit or new unit.	
Replace the new unit.	Replace either the old unit or new unit.	"PATTERN C"

NOTE:

Old unit means that the unit has been already used for another vehicle.

PATTERN A

1. Shift the selector lever to "P" position after replacing TCM. Turn the ignition switch ON.
2. Check that the shift position indicator in the combination meter turns ON (It indicates approximately 1 or 2 seconds after turning the ignition switch ON.)
 - Check the following items if the shift position indicator does not turn ON. Repair or replace the shift position indicator if necessary.
 - The harness between TCM and ROM ASSY in the transaxle assembly is open or short.
 - Cable disconnected, loosen, or bent from the connector housing.

PATTERN B

1. Turn the ignition switch ON after replacing each part.
2. Start engine.

CAUTION:

Do not start the driving.

3. Touch CONSULT-III screen in the order of "DATA MONITOR", and "MAIN SIGNALS".
4. Warm up the transaxle assembly until "ATF TEMP COUNT" indicates 47 [approximately 20°C(68°F)] or more. Turn the ignition switch OFF.
5. Turn the ignition switch ON.

PRECAUTIONS

< SERVICE INFORMATION >

CAUTION:

Do not start engine.

6. Select "SELF-DIAG RESULTS".
7. Shift the selector lever to "R" position.
8. Depress slightly the accelerator pedal (Pedal angle: 2/8) while depressing the brake pedal.
9. Perform "ERASE".
10. Shift the selector lever to "R" position after replacing TCM. Turn the ignition switch OFF.
11. Wait approximately 10 minutes after turning the ignition switch OFF.
12. Turn the ignition switch ON while shifting the selector lever to "R" position.

CAUTION:

Do not start engine.

13. Select "Special function".
14. Check that the value on "CALIBRATION DATA" is same as the data after erasing "Calibration Data".
 - Restart the procedure from step 3 if the values are not same.
15. Shift the selector lever to "P" position.
16. Check that the shift position indicator in the combination meter turns ON (It indicates approximately 1 or 2 seconds after shifting the selector lever to "P" position.)
 - Check the following items if the shift position indicator does not turn ON. Repair or replace the shift position indicator if necessary.
 - The harness between TCM and ROM ASSY in the transaxle assembly is open or short.
 - Cable disconnected, loosen, or bent from the connector housing.
 - Power supply and ground of TCM. Refer to [CVT-118](#).

Calibration Data

Data after deletion

Item name	Display value	Item name	Display value
UNIT CLB ID 1	0000	GAIN PL	256
UNIT CLB ID 2	0000	OFFSET PL	40
UNIT CLB ID 3	0000	OFFSET2 PL	0
UNIT CLB ID 4	0000	MAP NO SEC	32
UNIT CLB ID 5	0000	GAIN SEC	256
UNIT CLB ID 6	0000	OFFSET SEC	40
MAP NO LU	33	OFFSET2 SEC	0
GAIN LU	256	MAP NO SL	32
OFFSET LU	40	GAIN SL	256
OFFSET2 LU	0	OFFSET SL	40
MAP NO PL	32	OFFSET2 SL	0

PATTERN C

1. Replace the transaxle assembly first, and then replace TCM.
2. Perform the service of "PATTERN A".
(Perform the service of "PATTERN B" if TCM is replaced first.)

Removal and Installation Procedure for CVT Unit Connector

INFOID:000000004407044

REMOVAL

PRECAUTIONS

< SERVICE INFORMATION >

Rotate bayonet ring (1) counterclockwise, pull out CVT unit harness connector (2) outward and disconnect it.

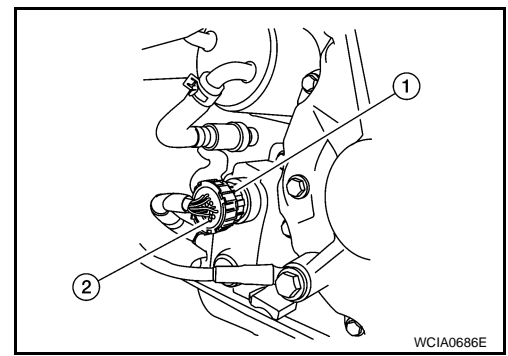

INSTALLATION

1. Align CVT unit harness connector terminal body marking with bayonet ring marking, insert CVT unit harness connector, and then rotate bayonet ring clockwise.

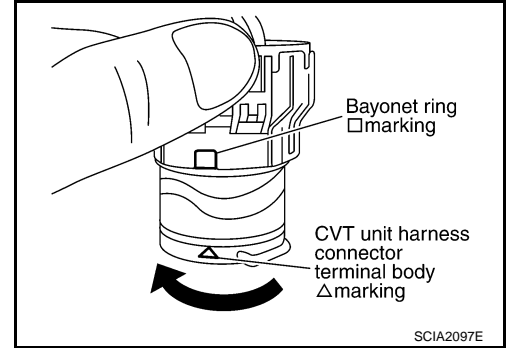

2. Rotate bayonet ring clockwise until CVT unit harness connector terminal body marking is aligned with the bayonet ring marking (linear slit) as shown.

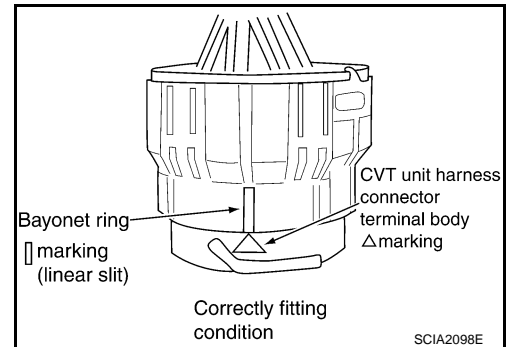

CAUTION:

- Securely align CVT unit harness connector terminal body marking with bayonet ring marking (linear slit). Do not make a half fit condition as shown.
- Do not mistake the bayonet ring marking (linear slit) for other dent portion.

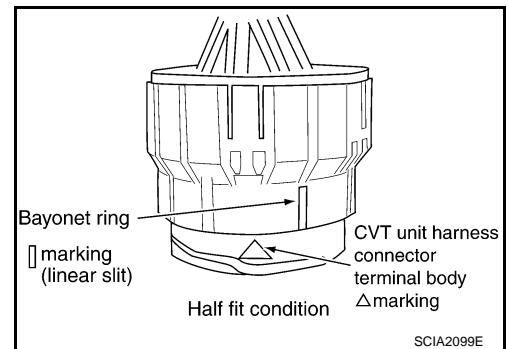

Precaution

INFOID:000000004407045

NOTE:

If any malfunction occurs in the RE0F10A model transaxle, replace the entire transaxle assembly.

PRECAUTIONS

< SERVICE INFORMATION >

- Before connecting or disconnecting the TCM harness connector, turn ignition switch OFF and disconnect negative battery cable. Because battery voltage is applied to TCM even if ignition switch is turned OFF.

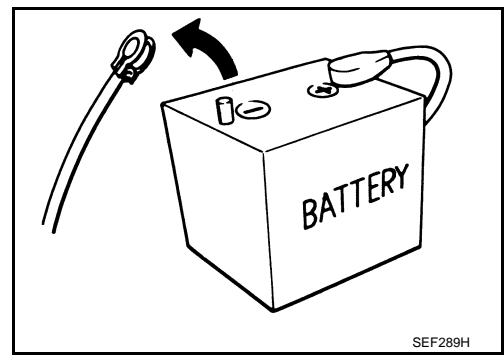

- When connecting or disconnecting pin connectors into or from TCM, take care not to damage pin terminals (bend or break).
When connecting pin connectors make sure that there are not any bends or breaks on TCM pin terminal.

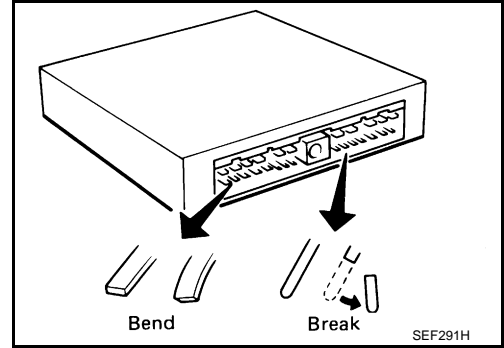

- Before replacing TCM, perform TCM input/output signal inspection and make sure whether TCM functions properly or not. [CVT-45, "TCM Input/Output Signal Reference Value"](#).

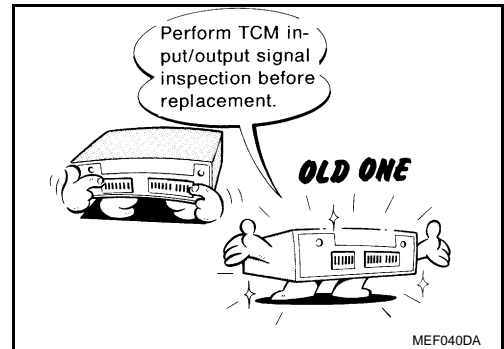

- After performing each TROUBLE DIAGNOSIS, perform "DTC Confirmation Procedure".
If the repair is completed the DTC should not be displayed in the "DTC Confirmation Procedure".

- Always use the specified brand of CVT fluid. Refer to [MA-14, "MR20DE"](#).

- Use lint-free paper, not cloth rags, during work.
- After replacing the CVT fluid, dispose of the waste oil using the methods prescribed by law, ordinance, etc.
- Before proceeding with disassembly, thoroughly clean the outside of the transaxle. It is important to prevent the internal parts from becoming contaminated by dirt or other foreign matter.
- Disassembly should be done in a clean work area.
- Place disassembled parts in order for easier and proper assembly.
- All parts should be carefully cleaned with a general purpose, non-flammable solvent before inspection or reassembly.
- Gaskets, seals and O-rings should be replaced.
- It is very important to perform functional tests whenever they are indicated.
- Before assembly, apply a coat of recommended ATF to all parts. Apply petroleum jelly to protect O-rings and seals.
- Extreme care should be taken to avoid damage to O-rings, seals and gaskets when assembling.
- Clean or replace CVT fluid cooler if excessive foreign material is found in oil pan.

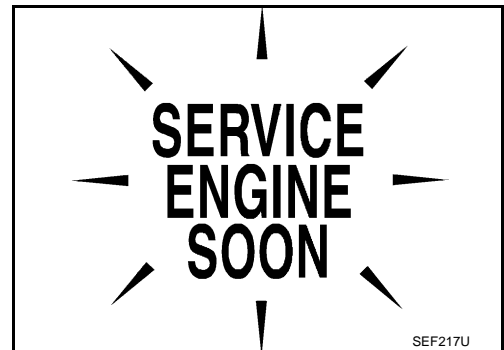

PRECAUTIONS

< SERVICE INFORMATION >

- When the CVT drain plug is removed, only some of the fluid is drained. Old CVT fluid will remain in torque converter and CVT fluid cooling system.
Always follow the procedures under “Changing CVT Fluid” in the CVT section when changing CVT fluid. Refer to [CVT-15. "Checking CVT Fluid"](#), [CVT-16. "Changing CVT Fluid"](#).

TORQUE CONVERTER SERVICE

The torque converter should be replaced under any of the following conditions:

- External leaks in the hub weld area.
- Converter hub is scored or damaged.
- Converter pilot is broken, damaged or fits poorly into crankshaft.
- Steel particles are found after flushing the cooler and cooler lines.
- Pump is damaged or steel particles are found in the converter.
- Vehicle has TCC shudder and/or no TCC apply. Replace only after all hydraulic and electrical diagnoses have been made. (Converter clutch material may be glazed.)
- Converter is contaminated with engine coolant containing antifreeze.
- Internal malfunction of stator roller clutch.
- Heavy clutch debris due to overheating (blue converter).
- Steel particles or clutch lining material found in fluid filter or on magnet when no internal parts in unit are worn or damaged — indicates that lining material came from converter.

The torque converter should not be replaced if:

- The fluid has an odor, is discolored, and there is no evidence of metal or clutch facing particles.
- The threads in one or more of the converter bolt holes are damaged.
- CVT malfunction did not display evidence of damaged or worn internal parts, steel particles or clutch plate lining material in unit and inside the fluid filter.
- Vehicle has been exposed to high mileage (only). The exception may be where the torque converter clutch dampener plate lining has seen excess wear by vehicles operated in heavy and/or constant traffic, such as taxi, delivery or police use.

Service Notice or Precaution

INFOID:000000004407046

OBD-II SELF-DIAGNOSIS

- CVT self-diagnosis is performed by the TCM in combination with the ECM. The results can be read through the blinking pattern of the malfunction indicator lamp (MIL). Refer to the table on [CVT-47. "CONSULT-III Function \(TRANSMISSION\)"](#) for the indicator used to display each self-diagnostic result.
- The self-diagnostic results indicated by the MIL are automatically stored in both the ECM and TCM memories.

Always perform the procedure on [CVT-25. "OBD-II Diagnostic Trouble Code \(DTC\)"](#) to complete the repair and avoid unnecessary blinking of the MIL.

For details of OBD-II, refer to [EC-59](#).

- **Certain systems and components, especially those related to OBD, may use the new style slide-locking type harness connector. For description and how to disconnect, refer to [PG-59](#).**

ATFTEMP COUNT Conversion Table

INFOID:000000004407047

ATFTEMP COUNT	Temperature °C (°F)	ATFTEMP COUNT	Temperature °C (°F)
4	-30 (-22)	177	90 (194)
8	-20 (-4)	183	95 (203)
13	-10 (14)	190	100 (212)
17	-5 (23)	196	105 (221)
21	0 (32)	201	110 (230)
27	5 (41)	206	115 (239)
32	10 (50)	210	120 (248)
39	15 (59)	214	125 (257)
47	20 (68)	218	130 (266)
55	25 (77)	221	135 (275)
64	30 (86)	224	140 (284)

PRECAUTIONS

< SERVICE INFORMATION >

ATFTEMP COUNT	Temperature °C (°F)	ATFTEMP COUNT	Temperature °C (°F)	
73	35 (95)	227	145 (293)	A
83	40 (104)	229	150 (302)	
93	45 (113)	231	155 (311)	B
104	50 (122)	233	160 (320)	
114	55 (131)	235	165 (329)	
124	60 (140)	236	170 (338)	CVT
134	65 (149)	238	175 (347)	
143	70 (158)	239	180 (356)	D
152	75 (167)	241	190 (374)	
161	80 (176)	243	200 (392)	E
169	85 (185)	—	—	

A

B

CVT

D

E

F

G

H

I

J

K

L

M

N

O

P

PREPARATION

< SERVICE INFORMATION >

PREPARATION

Special Service Tool

INFOID:000000004407048

The actual shapes of Kent-Moore tools may differ from those of special service tools illustrated here.

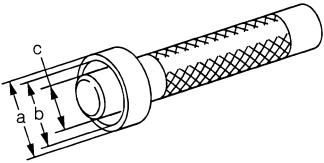
Tool number (Kent-Moore No.) Tool name	Description
<p>— (OTC3492) Oil pressure gauge set</p>  <p style="text-align: right;">SCIA7531E</p>	Measuring line pressure
<p>KV38100300 (—) Drift</p>  <p style="text-align: right;">ZZA1046D</p>	<p>Installing differential side oil seal a: 54 mm (2.13 in) b: 46 mm (1.81 in) c: 32 mm (1.26 in)</p>

Commercial Service Tool

INFOID:000000004407049

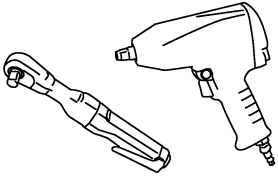
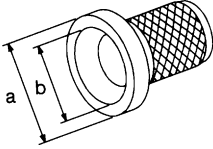
Tool number Tool name	Description
<p>Power tool</p>  <p style="text-align: right;">PBIC0190E</p>	Loosening nuts and bolts
<p>Drift</p>  <p style="text-align: right;">NT086</p>	<p>Installing converter housing oil seal a: ϕ 65 mm (2.56 in) b: ϕ 60 mm (2.36 in)</p>

CVT FLUID

< SERVICE INFORMATION >

CVT FLUID

Checking CVT Fluid

INFOID:000000004407050

FLUID LEVEL CHECK

Fluid level should be checked with the fluid warmed up to 50° to 80°C (122° to 176°F).

1. Check for fluid leakage.
2. With the engine warmed up, drive the vehicle to warm up the CVT fluid. When ambient temperature is 20°C (68°F), it takes about 10 minutes for the CVT fluid to warm up to 50° to 80°C (122° to 176°F).
3. Park the vehicle on a level surface and set the parking brake.
4. With engine at idle, while depressing brake pedal, move the selector lever throughout the entire shift range and return it to the "P" position.

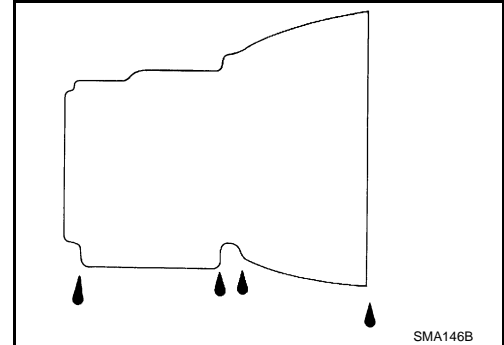

5. Press the tab on the CVT fluid level gauge to release the lock and pull out the CVT fluid level gauge from the CVT fluid charging pipe.

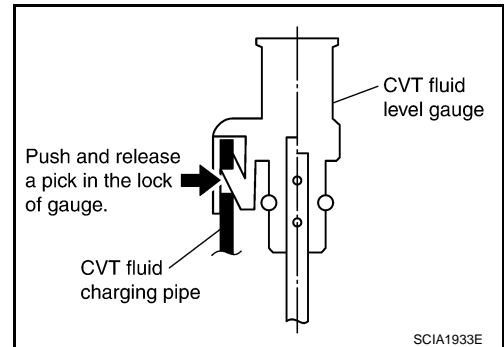

6. Wipe fluid off the CVT fluid level gauge. Then rotate the CVT fluid level gauge 180° and re-insert it into the CVT charging pipe as far as it will go.

CAUTION:

Always use lint free paper towels to wipe fluid off the CVT fluid level gauge.

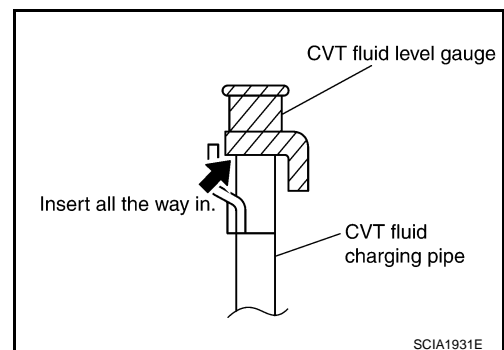

7. Remove the CVT fluid level gauge and check that the fluid level is within the specified range as shown. If the fluid level is at or below the low side of the range, add the necessary specified NISSAN CVT fluid through the CVT charging pipe.

Fluid grade: Refer to [MA-14, "MR20DE"](#).

CAUTION:

- Only use specified NISSAN CVT fluid.
- Do not overfill the CVT.

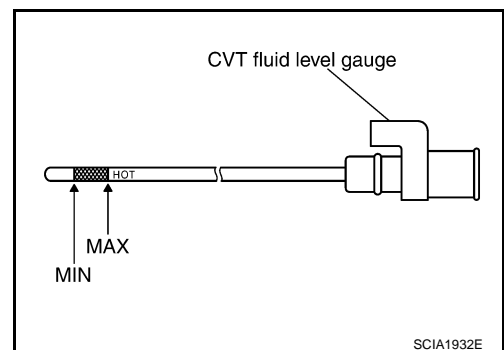

8. Install the CVT fluid level gauge to the CVT fluid charging pipe until it locks.

CAUTION:

When CVT fluid level gauge is installed into the CVT fluid charging pipe, make sure that the CVT fluid level gauge is securely locked in place.

A

B

CVT

D

E

F

G

H

I

J

K

L

M

N

O

P

CVT FLUID

< SERVICE INFORMATION >

FLUID CONDITION CHECK

Fluid status	Conceivable cause	Required operation
Varnished (viscous varnish state)	CVT fluid become degraded due to high temperatures.	Replace the CVT fluid and check the CVT main unit and the vehicle for malfunctions (wire harness, cooler pipes, etc.)
Milky white or cloudy	Water in the fluid	Replace the CVT fluid and check for places where water is getting in.
Large amount of metal powder mixed in fluid	Unusual wear of sliding parts within CVT	Replace the CVT fluid and check for improper operation of the CVT.

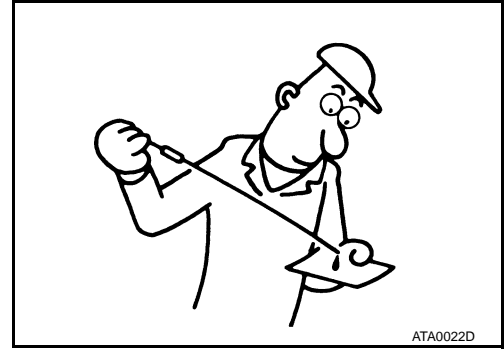

ATA0022D

Changing CVT Fluid

INFOID:000000004780830

- Warm up CVT fluid by driving the vehicle for 10 minutes.
 - ↔: Vehicle front
 - Radiator (2)
 - CVT fluid cooler hose [inlet side (3)]
 - Transaxle assembly (4)
- Drain CVT fluid from CVT fluid cooler hose [outlet side (1)] and refill with new specified NISSAN CVT fluid in the CVT fluid charging pipe with the engine running at idle speed.
- Refill until new CVT fluid comes out from CVT fluid cooler hose [outlet side (1)].

NOTE:
About 30 to 50% extra fluid will be required for this procedure.
- Check fluid level and condition. Refer to [CVT-15, "Checking CVT Fluid"](#).

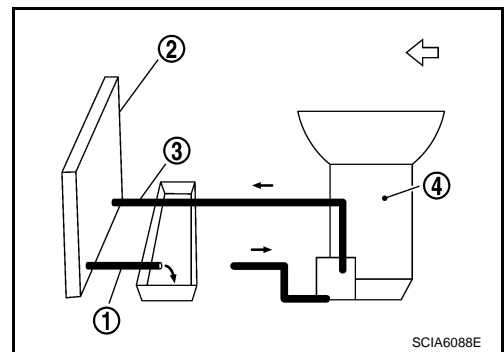

SCIA6088E

CVT fluid : Refer to [MA-14, "MR20DE"](#) or [MA-14, "QR25DE"](#)

Fluid capacity : Refer to [MA-14, "MR20DE"](#) or [MA-14, "QR25DE"](#)

CAUTION:

- Use only Genuine NISSAN CVT Fluid NS-2. Never mix with other fluid.
- Using CVT fluid other than Genuine NISSAN CVT Fluid NS-2 will deteriorate in driveability and CVT durability, and may damage the CVT, which is not covered by the warranty.
- When filling CVT fluid, take care not to scatter heat generating parts such as exhaust.
- Sufficiently shake the container of CVT fluid before using.
- Delete CVT fluid deterioration date with CONSULT-III after changing CVT fluid. Refer to TM-34, "CONSULT-III Function (TRANSMISSION)".

CVT SYSTEM

< SERVICE INFORMATION >

CVT SYSTEM

Cross-Sectional View - RE0F10A

INFOID:000000004407052

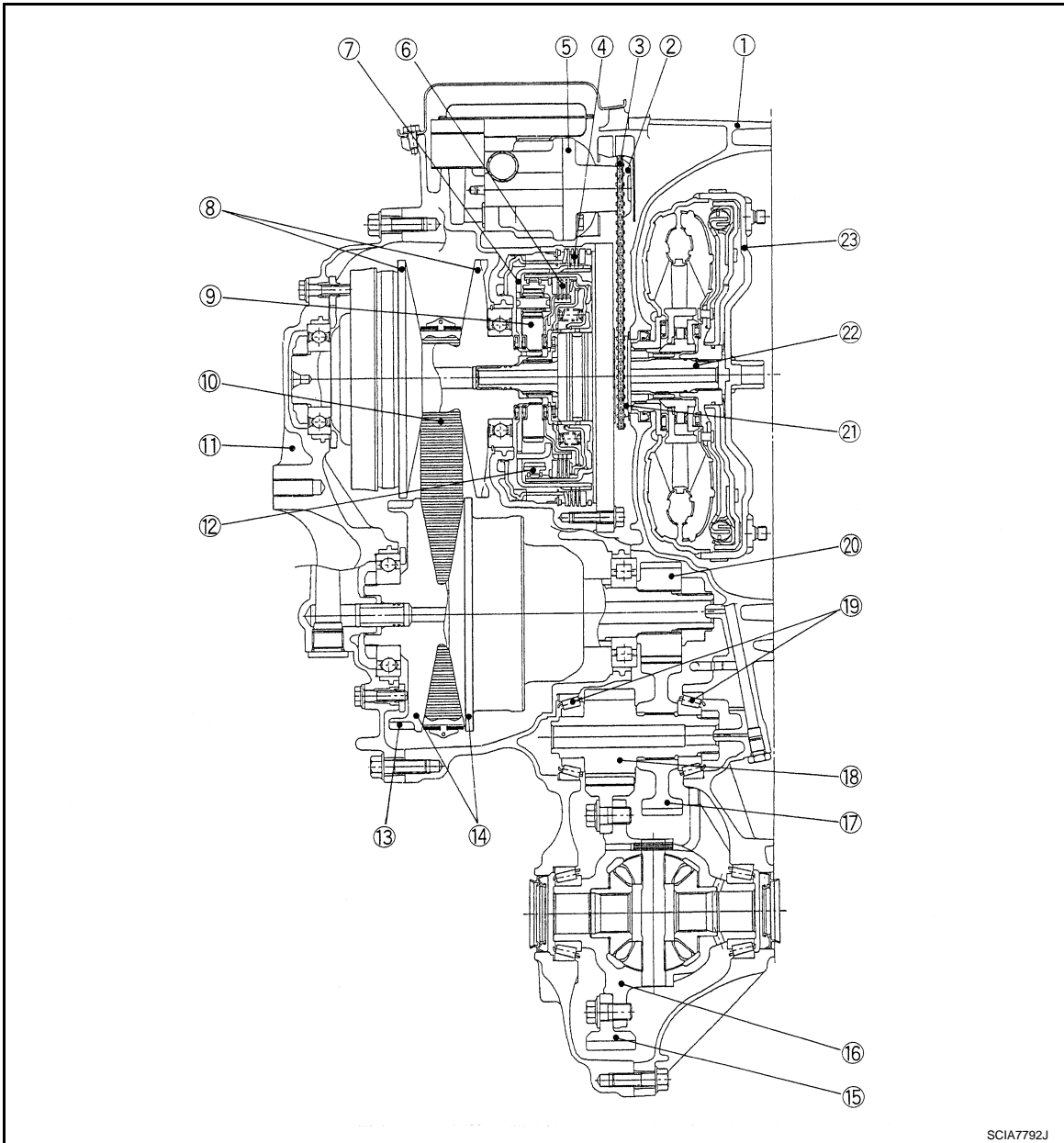

- | | | |
|--------------------------|----------------------|--------------------|
| 1. Converter housing | 2. Driven sprocket | 3. Chain |
| 4. Reverse brake | 5. Oil pump | 6. Forward clutch |
| 7. Planetary carrier | 8. Primary pulley | 9. Sun gear |
| 10. Steel belt | 11. Side cover | 12. Internal gear |
| 13. Parking gear | 14. Secondary pulley | 15. Final gear |
| 16. Differential case | 17. Idler gear | 18. Reduction gear |
| 19. Taper roller bearing | 20. Output gear | 21. Drive sprocket |
| 22. Input shaft | 23. Torque converter | |

A

B

CVT

D

E

F

G

H

I

J

K

L

M

N

O

P

CVT SYSTEM

< SERVICE INFORMATION >

Control System

INFOID:000000004407053

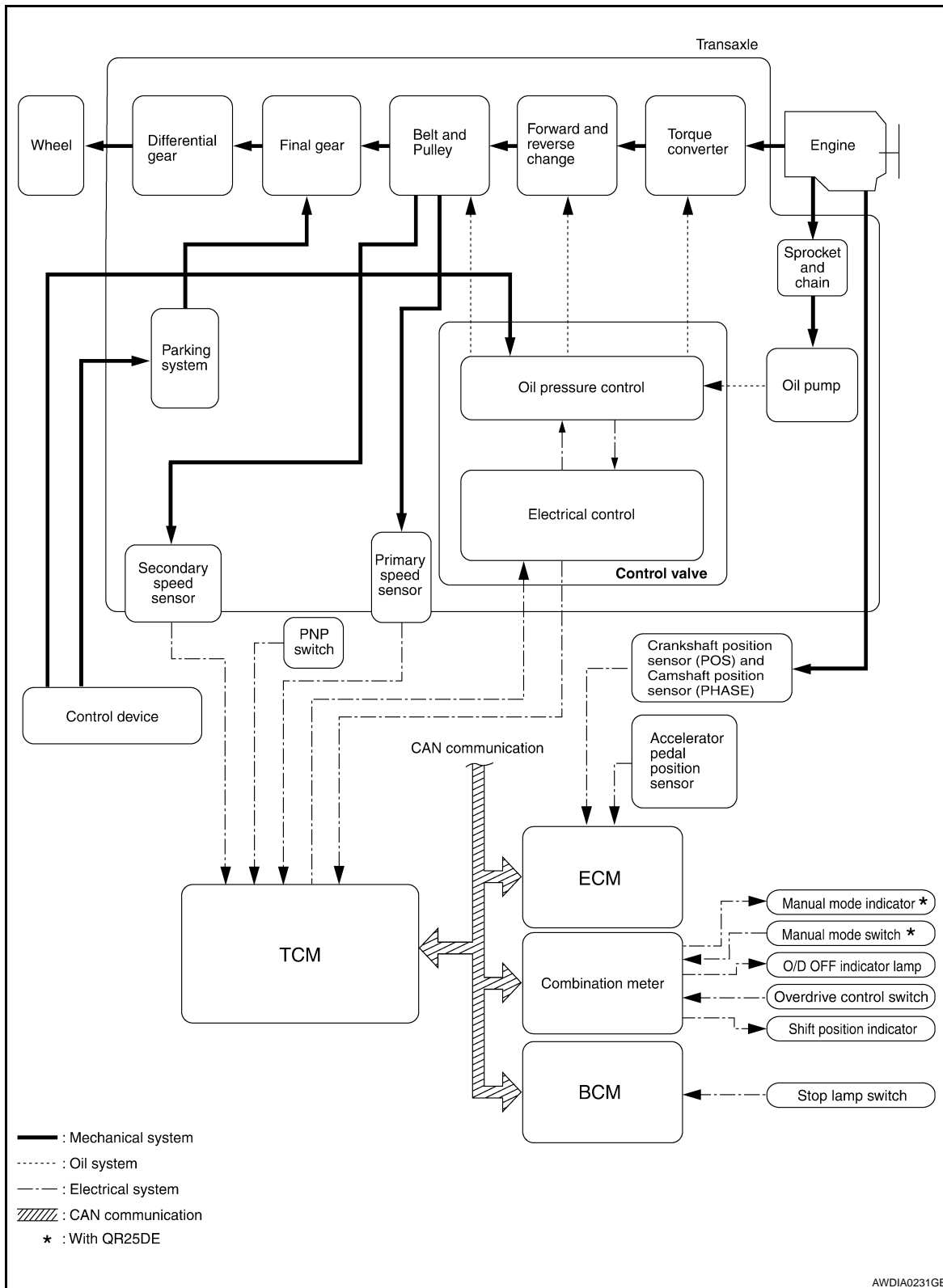

CVT SYSTEM

< SERVICE INFORMATION >

Hydraulic Control System

INFOID:000000004407054

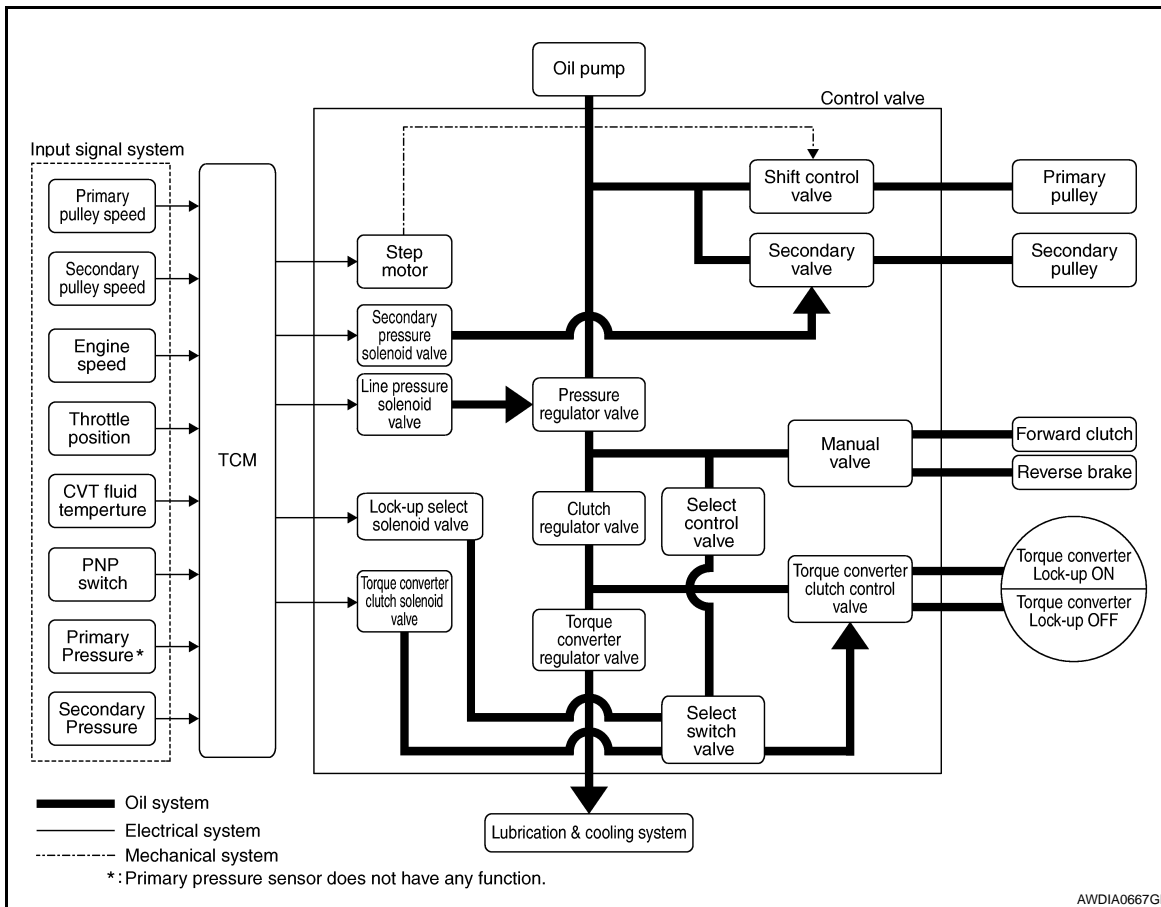

TCM Function

INFOID:000000004407055

The function of the TCM is to:

- Receive input signals sent from various switches and sensors.
- Determine required line pressure, shifting point, and lock-up operation.
- Send required output signals to the step motor and the respective solenoids.

CONTROL SYSTEM OUTLINE

The CVT senses vehicle operating conditions through various sensors. It always controls the optimum shift position and reduces shifting and lock-up shocks.

SENSORS (or SIGNAL)		TCM		ACTUATORS
PNP switch Accelerator pedal position signal Closed throttle position signal Engine speed signal CVT fluid temperature sensor Vehicle speed signal Overdrive control signal Manual mode switch signal* Stop lamp switch signal Primary speed sensor Secondary speed sensor Primary pressure sensor** Secondary pressure sensor	⇒	Shift control Line pressure control Primary pressure control Secondary pressure control Lock-up control Engine brake control Vehicle speed control Fail-safe control Self-diagnosis CONSULT-III communication line Duet-EA control CAN system On board diagnosis	⇒	Step motor Torque converter clutch solenoid valve Lock-up select solenoid valve Line pressure solenoid valve Secondary pressure solenoid valve Shift position indicator O/D OFF indicator lamp Manual mode indicator* Starter relay

*: With QR25DE

** : Primary pressure sensor does not have any function.

CVT SYSTEM

< SERVICE INFORMATION >

CONTROL SYSTEM DIAGRAM

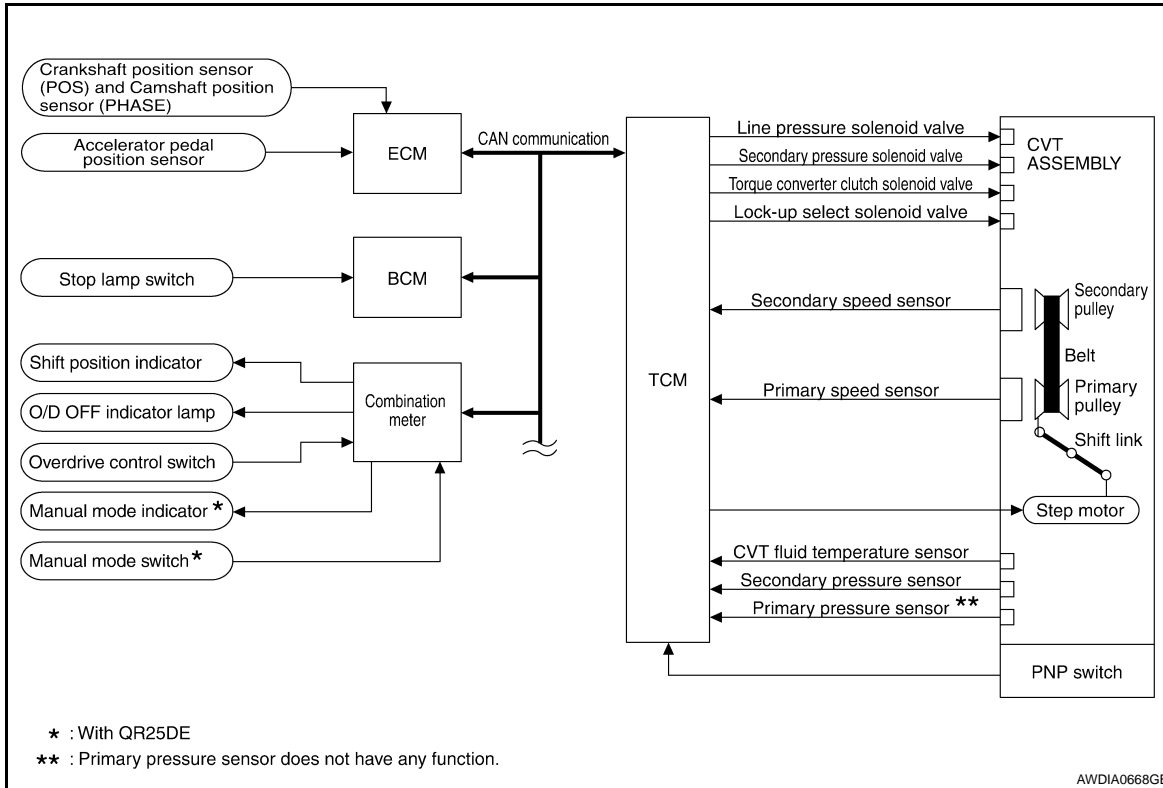

CAN Communication

INFOID:000000004407056

SYSTEM DESCRIPTION

Refer to [LAN-6, "System Description"](#).

Input/Output Signal of TCM

INFOID:000000004407057

Control item		Fluid pressure control	Select control	Shift control	Lock-up control	CAN communication control	Fail-safe function (*3)
Input	PNP switch	X	X	X	X	X	X
	Accelerator pedal position signal (*1)	X	X	X	X	X	X
	Closed throttle position signal(*1)	X		X	X	X	
	Engine speed signal(*1)	X	X		X	X	X
	CVT fluid temperature sensor	X	X	X	X		X
	Stop lamp switch signal(*1)	X		X	X	X	X
	Overdrive control signal(*1)			X		X	
	Primary speed sensor	X		X	X		X
	Secondary speed sensor	X	X	X	X		X
	Primary pressure sensor(*4)	X					
	Secondary pressure sensor	X					X

CVT SYSTEM

< SERVICE INFORMATION >

Control item		Fluid pressure control	Select control	Shift control	Lock-up control	CAN communication control	Fail-safe function (*3)
Output	Step motor			X			X
	TCC solenoid valve		X		X		X
	Lock-up select solenoid valve		X		X		X
	Line pressure solenoid valve	X	X				X
	Secondary pressure solenoid valve	X					X
	O/D OFF indicator signal(*2)			X		X	

*1: Input by CAN communications.

*2: Output by CAN communications.

*3: If these input and output signals are different, the TCM triggers the fail-safe function.

*4: Primary pressure sensor does not have any function.

Line Pressure and Secondary Pressure Control

INFOID:000000004407058

- When an input torque signal equivalent to the engine drive force is sent from the ECM to the TCM, the TCM controls the line pressure solenoid valve and secondary pressure solenoid valve.
- This line pressure solenoid controls the pressure regulator valve as the signal pressure and adjusts the pressure of the operating oil discharged from the oil pump to the line pressure most appropriate to the driving state. Secondary pressure is controlled by decreasing line pressure.

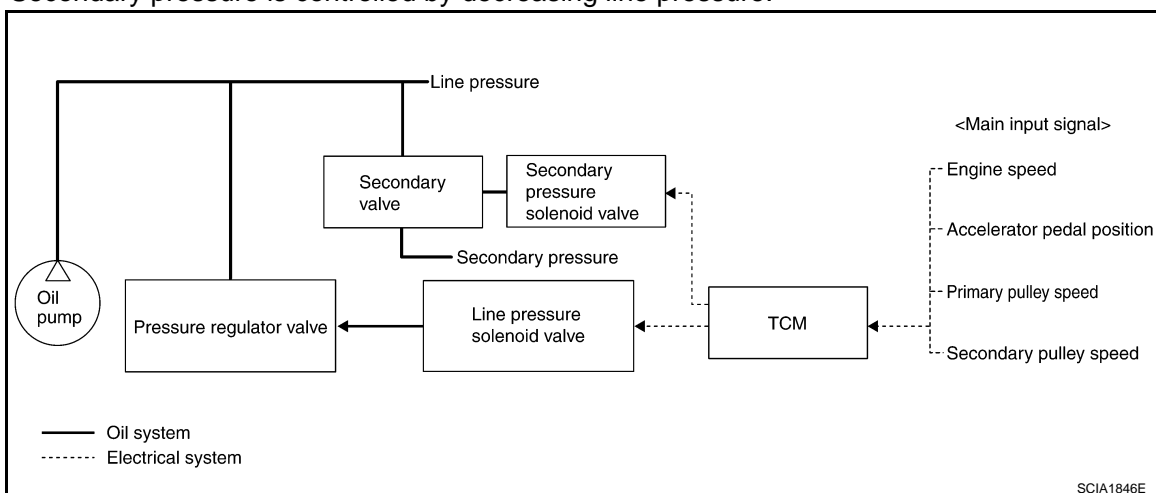

NORMAL CONTROL

Optimize the line pressure and secondary pressure, depending on driving conditions, on the basis of the throttle position, the engine speed, the primary pulley (input) revolution speed, the secondary pulley (output) revolution speed, the brake signal, the PNP switch signal, the lock-up signal, the voltage, the target gear ratio, the fluid temperature, and the fluid pressure.

FEEDBACK CONTROL

When controlling the normal fluid pressure or the selected fluid pressure, the secondary pressure can be set more accurately by using the fluid pressure sensor to detect the secondary pressure and controlling the feedback.

Shift Control

INFOID:000000004407059

In order to select the gear ratio which can obtain the driving force in accordance with driver's intention and the vehicle condition, TCM monitors the driving conditions, such as the vehicle speed and the throttle position and selects the optimum gear ratio, and determines the gear change steps to the gear ratio. Then send the com-

CVT SYSTEM

< SERVICE INFORMATION >

mand to the step motor, and control the flow-in/flow-out of line pressure from the primary pulley to determine the position of the moving-pulley and control the gear ratio.

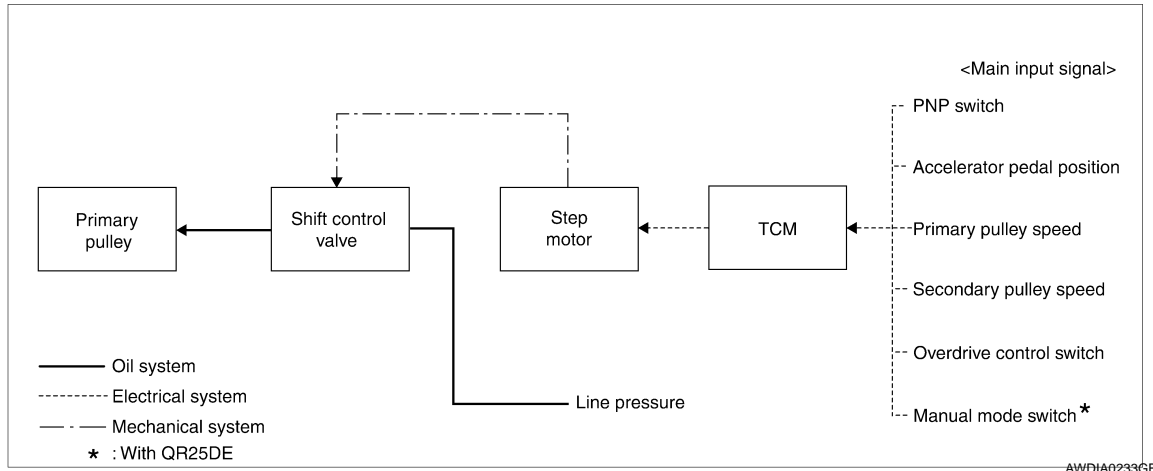

NOTE:

The gear ratio is set for every position separately.

“D” POSITION

Shifting over all the ranges of gear ratios from the lowest to the highest.

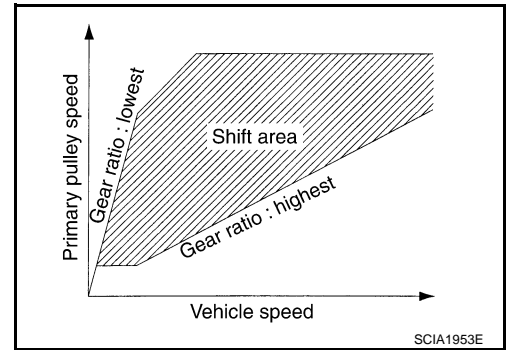

“D” POSITION OVERDRIVE SWITCH: ON

Gear ratio increases in general by limiting gear range on the HIGH side of the gear ratio, and this allows the generation of the constant strong driving force.

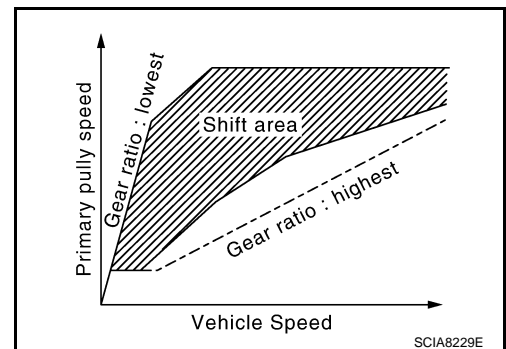

“L” POSITION

By limiting the gear range to the lowest position, the strong driving force and the engine brake can be secured.

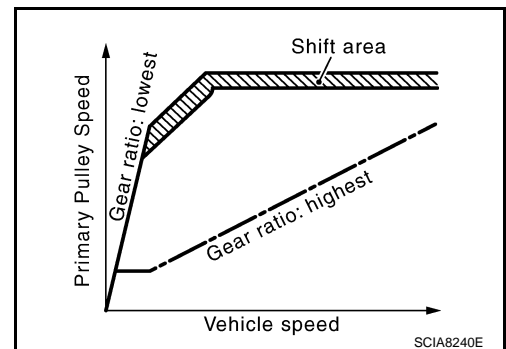

“M” POSITION (With QR25DE)

CVT SYSTEM

< SERVICE INFORMATION >

When the selector lever is put in the manual shift gate side, the fixed changing gear line is set. By moving the steering shift switch to + side or - side, the manual mode switch is changed over, and shift change like M/T becomes possible following the changing gear set line step by step.

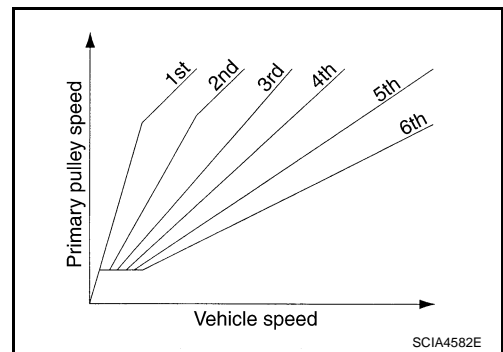

DOWNHILL ENGINE BRAKE CONTROL (AUTO ENGINE BRAKE CONTROL)

When downhill is detected with the accelerator pedal released, the engine brake will be strengthened up by downshifting so as not to accelerate the vehicle more than necessary.

ACCELERATION CONTROL

According to vehicle speed and a change of accelerator pedal angle, driver's request for acceleration and driving scene are judged. This function assists improvement in acceleration feeling by making the engine speed proportionate to the vehicle speed. And a shift map which can gain a larger driving force is available for compatibility of mileage with drivability.

Lock-up and Select Control

INFOID:000000004407060

- The torque converter clutch piston in the torque converter is engaged to eliminate torque converter slip to increase power transmission efficiency.
- The torque converter clutch control valve operation is controlled by the torque converter clutch solenoid valve, which is controlled by a signal from TCM. The torque converter clutch control valve engages or releases the torque converter clutch piston.
- When shifting between "N" ("P") ↔ "D" ("R"), torque converter clutch solenoid controls engagement power of forward clutch and reverse brake.
- The lock-up applied gear range was expanded by locking up the torque converter at a lower vehicle speed than conventional CVT models.

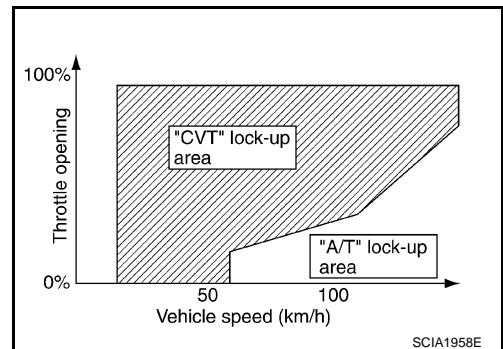

TORQUE CONVERTER CLUTCH AND SELECT CONTROL VALVE CONTROL

CVT SYSTEM

< SERVICE INFORMATION >

Lock-up and Select Control System Diagram

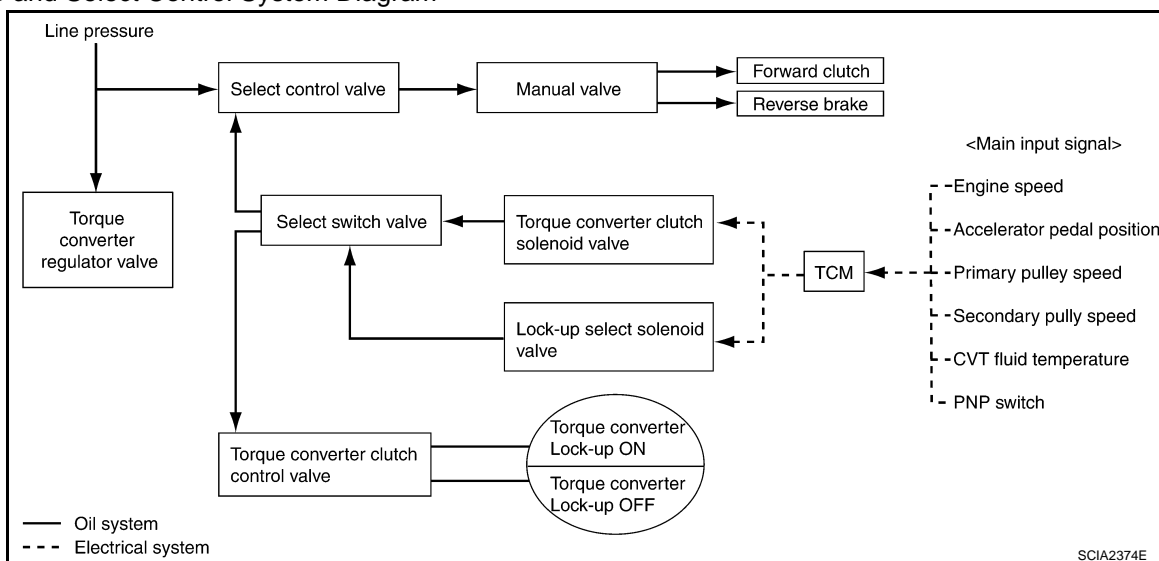

Lock-up Released

In the lock-up released state, the torque converter clutch control valve is set into the unlocked state by the torque converter clutch solenoid and the lock-up apply pressure is drained. In this way, the torque converter clutch piston is not coupled.

Lock-up Applied

In the lock-up applied state, the torque converter clutch control valve is set into the locked state by the torque converter clutch solenoid and lock-up apply pressure is generated. In this way, the torque converter clutch piston is pressed and coupled.

Select Control

When shifting between "N" ("P") ⇌ "D" ("R"), optimize the operating pressure on the basis of the throttle position, the engine speed, and the secondary pulley (output) revolution speed to lessen the shift shock.

Control Valve

INFOID:000000004407061

FUNCTION OF CONTROL VALVE

Name	Function
Torque converter regulator valve	Optimizes the supply pressure for the torque converter depending on driving conditions.
Pressure regulator valve	Optimizes the discharge pressure from the oil pump depending on driving conditions.
TCC control valve	<ul style="list-style-type: none"> Activates or deactivate the lock-up. Lock-up smoothly by opening lock-up operation excessively.
TCC solenoid valve	Controls the TCC control valve or select control valve.
Shift control valve	Controls flow-in/out of line pressure from the primary pulley depending on the stroke difference between the stepping motor and the primary pulley.
Secondary valve	Controls the line pressure from the secondary pulley depending on operating conditions.
Clutch regulator valve	Adjusts the clutch operating pressure depending on operating conditions.
Secondary pressure solenoid valve	Controls the secondary valve.
Line pressure solenoid valve	Controls the line pressure control valve.
Step motor	Controls the pulley ratio.
Manual valve	Transmits the clutch operating pressure to each circuit in accordance with the selected position.
Select control valve	Engages forward clutch, reverse brake smoothly depending on select operation.
Select switch valve	Switches torque converter clutch solenoid valve control pressure use to torque converter clutch control valve or select control valve.
Lock-up select solenoid valve	Controls the select switch valve.

ON BOARD DIAGNOSTIC (OBD) SYSTEM

< SERVICE INFORMATION >

ON BOARD DIAGNOSTIC (OBD) SYSTEM

Introduction

INFOID:000000004407062

The CVT system has two self-diagnostic systems.

The first is the emission-related on board diagnostic system (OBD-II) performed by the TCM in combination with the ECM. The malfunction is indicated by the MIL (malfunction indicator lamp) and is stored as a DTC in the ECM memory, and the TCM memory.

The second is the TCM original self-diagnosis performed by the TCM. The malfunction is stored in the TCM memory. The detected items are overlapped with OBD-II self-diagnostic items. For detail, refer to [CVT-47, "CONSULT-III Function \(TRANSMISSION\)"](#).

OBD-II Function for CVT System

INFOID:000000004407063

The ECM provides emission-related on board diagnostic (OBD-II) functions for the CVT system. One function is to receive a signal from the TCM used with OBD-related parts of the CVT system. The signal is sent to the ECM when a malfunction occurs in the corresponding OBD-related part. The other function is to indicate a diagnostic result by means of the MIL (malfunction indicator lamp) on the instrument panel. Sensors, switches and solenoid valves are used as sensing elements.

The MIL automatically illuminates in One or Two Trip Detection Logic when a malfunction is sensed in relation to CVT system parts.

One or Two Trip Detection Logic of OBD-II

INFOID:000000004407064

ONE TRIP DETECTION LOGIC

If a malfunction is sensed during the first test drive, the MIL will illuminate and the malfunction will be stored in the ECM memory as a DTC. The TCM is not provided with such a memory function.

TWO TRIP DETECTION LOGIC

When a malfunction is sensed during the first test drive, it is stored in the ECM memory as a 1st trip DTC (diagnostic trouble code) or 1st trip freeze frame data. At this point, the MIL will not illuminate. — 1st trip

If the same malfunction as that experienced during the first test drive is sensed during the second test drive, the MIL will illuminate. — 2nd trip

The "trip" in the "One or Two Trip Detection Logic" means a driving mode in which self-diagnosis is performed during vehicle operation.

OBD-II Diagnostic Trouble Code (DTC)

INFOID:000000004407065

HOW TO READ DTC AND 1ST TRIP DTC

DTC and 1st trip DTC can be read by the following methods.

( **With CONSULT-III** or ( **GST**) CONSULT-III or GST (Generic Scan Tool) Examples: P0705, P0720 etc.

These DTC are prescribed by SAE J2012.

(CONSULT-III also displays the malfunctioning component or system.)

- **1st trip DTC No. is the same as DTC No.**
 - **Output of the diagnostic trouble code indicates that the indicated circuit has a malfunction. However, in case of the Mode II and GST, they do not indicate whether the malfunction is still occurring or occurred in the past and returned to normal.**
- CONSULT-III can identify them as shown below, therefore, CONSULT-III (if available) is recommended.**

A sample of CONSULT-III display for DTC and 1st trip DTC is shown on the next page. DTC or 1st trip DTC of a malfunction is displayed in SELF-DIAGNOSTIC RESULTS mode for "ENGINE" with CONSULT-III. Time data indicates how many times the vehicle was driven after the last detection of a DTC.

If the DTC is being detected currently, the time data will be "0".

If a 1st trip DTC is stored in the ECM, the time data will be "1t".

Freeze Frame Data and 1st Trip Freeze Frame Data

The ECM has a memory function, which stores the driving condition such as fuel system status, calculated load value, engine coolant temperature, short term fuel trim, long term fuel trim, engine speed and vehicle speed at the moment the ECM detects a malfunction.

A

B

CVT

D

E

F

G

H

I

J

K

L

M

N

O

P

ON BOARD DIAGNOSTIC (OBD) SYSTEM

< SERVICE INFORMATION >

Data which are stored in the ECM memory, along with the 1st trip DTC, are called 1st trip freeze frame data, and the data, stored together with the DTC data, are called freeze frame data and displayed on CONSULT-III or GST. The 1st trip freeze frame data can only be displayed on the CONSULT-III screen, not on the GST. For details, refer to [EC-123. "CONSULT-III Function \(ENGINE\)"](#).

Only one set of freeze frame data (either 1st trip freeze frame data or freeze frame data) can be stored in the ECM. 1st trip freeze frame data is stored in the ECM memory along with the 1st trip DTC. There is no priority for 1st trip freeze frame data, and it is updated each time a different 1st trip DTC is detected. However, once freeze frame data (2nd trip detection/MIL on) is stored in the ECM memory, 1st trip freeze frame data is no longer stored. Remember, only one set of freeze frame data can be stored in the ECM. The ECM has the following priorities to update the data.

Priority	Items	
1	Freeze frame data	Misfire — DTC: P0300 - P0306 Fuel Injection System Function — DTC: P0171, P0172, P0174, P0175
2		Except the above items (Includes CVT related items)
3	1st trip freeze frame data	

Both 1st trip freeze frame data and freeze frame data (along with the DTC) are cleared when the ECM memory is erased.

HOW TO ERASE DTC

The diagnostic trouble code can be erased by CONSULT-III, GST or ECM DIAGNOSTIC TEST MODE as described following.

- **If the battery cable is disconnected, the diagnostic trouble code will be lost within 24 hours.**
- **When you erase the DTC, using CONSULT-III or GST is easier and quicker than switching the mode selector on the ECM.**

The following emission-related diagnostic information is cleared from the ECM memory when erasing DTC related to OBD-II. For details, refer to [EC-60. "Emission-related Diagnostic Information"](#).

- **Diagnostic trouble codes (DTC)**
- **1st trip diagnostic trouble codes (1st trip DTC)**
- **Freeze frame data**
- **1st trip freeze frame data**
- **System readiness test (SRT) codes**
- **Test values**

HOW TO ERASE DTC (WITH CONSULT-III)

- **If a DTC is displayed for both ECM and TCM, it is necessary to be erased for both ECM and TCM.**
1. Perform DELETING DTC.
 2. Make sure that all "DTC RESULT", "TIME" and "FDD" are deleted.

HOW TO ERASE DTC (WITH GST)

1. If the ignition switch stays ON after repair work, be sure to turn ignition switch OFF once. Wait at least 10 seconds and then turn it ON (engine stopped) again.
2. Select Mode 4 with GST (Generic Scan Tool). For details, refer to [EC-131. "Generic Scan Tool \(GST\) Function"](#).

Malfunction Indicator Lamp (MIL)

INFOID:000000004407066

DESCRIPTION

ON BOARD DIAGNOSTIC (OBD) SYSTEM

< SERVICE INFORMATION >

The MIL is located on the instrument panel.

1. The MIL will light up when the ignition switch is turned ON without the engine running. This is a bulb check.
 - If the MIL does not light up, refer to [DI-31](#), or see [EC-565](#).
2. When the engine is started, the MIL should go off.
 - If the MIL remains on, the on board diagnostic system has detected an engine system malfunction.

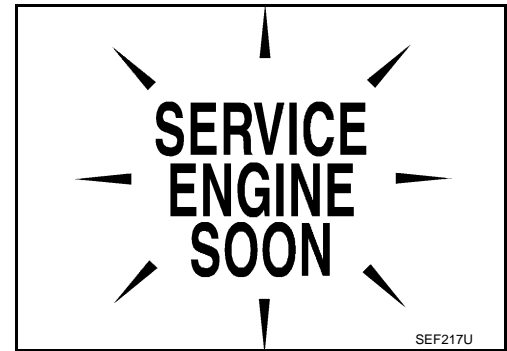

A

B

CVT

D

E

F

G

H

I

J

K

L

M

N

O

P

TROUBLE DIAGNOSIS

< SERVICE INFORMATION >

TROUBLE DIAGNOSIS

DTC Inspection Priority Chart

INFOID:000000004407067

If some DTCs are displayed at the same time, perform inspections one by one based on the following priority chart.

NOTE:

If DTC “U1000 CAN COMM CIRCUIT” is displayed with other DTCs, first perform the trouble diagnosis for “DTC U1000 CAN COMMUNICATION LINE”. Refer to [CVT-55](#).

Priority	Detected items (DTC)
1	U1000 CAN communication line
2	Except above

Fail-Safe

INFOID:000000004407068

The TCM has an electrical fail-safe mode. This mode makes it possible to operate even if there is an error in a main electronic control input/output signal circuit.

FAIL-SAFE FUNCTION

If any malfunction occurs in a sensor or solenoid, this function controls the CVT to make driving possible.

Output Speed Sensor (Secondary Speed Sensor)

The shift pattern is changed in accordance with throttle position when an unexpected signal is sent from the output speed sensor (secondary speed sensor) to the TCM. The overdrive-off mode is inhibited, and the transaxle is put in “D”.

Input Speed Sensor (Primary Speed Sensor)

The shift pattern is changed in accordance with throttle position and secondary speed (vehicle speed) when an unexpected signal is sent from the input speed sensor (primary speed sensor) to the TCM. The overdrive-off mode is inhibited, and the transaxle is put in “D”.

PNP Switch

If an unexpected signal is sent from the PNP switch to the TCM, the transaxle is put in “D”.

Manual Mode Switch (with QR25DE)

If an unexpected signal is sent from the manual mode switch to the TCM, the transaxle is put in “D”.

CVT Fluid Temperature Sensor

If an unexpected signal is sent from the CVT fluid temperature sensor to the TCM, the gear ratio in use before receiving the unexpected signal is maintained or the gear ratio is controlled to keep engine speed under 4500 rpm.

Transmission Fluid Pressure Sensor A (Secondary Pressure Sensor)

- If an unexpected signal is sent from the transmission fluid pressure sensor A (secondary pressure sensor) to the TCM, the secondary pressure feedback control is stopped and the offset value obtained before the non-standard condition occurs is used to control line pressure.
- If transmission fluid pressure sensor A (secondary pressure sensor) error signal is input to TCM, secondary pressure feedback control stops, but line pressure is controlled normally.

Pressure Control Solenoid A (Line Pressure Solenoid)

If an unexpected signal is sent from the solenoid to the TCM, the pressure control solenoid A (line pressure solenoid) is turned OFF to achieve the maximum fluid pressure.

Pressure Control Solenoid B (Secondary Pressure Solenoid)

If an unexpected signal is sent from the solenoid to the TCM, the pressure control solenoid B (secondary pressure solenoid) is turned OFF to achieve the maximum fluid pressure.

Torque Converter Clutch Solenoid

If an unexpected signal is sent from the solenoid to the TCM, the torque converter clutch solenoid is turned OFF to cancel the lock-up.

Step Motor

If an unexpected signal is sent from the step motor to the TCM, the step motor coil phases “A” through “D” are all turned OFF to hold the gear ratio used right before the non-standard condition occurred.

TROUBLE DIAGNOSIS

< SERVICE INFORMATION >

CVT Lock-up Select Solenoid

If an unexpected signal is sent from the solenoid to the TCM, the CVT lock-up select solenoid is turned OFF to cancel the lock-up.

TCM Power Supply (Memory Back-up)

Transaxle assembly is protected by limiting the engine torque when the memory back-up power supply (for controlling) from the battery is not supplied to TCM. Normal status is restored when turning the ignition switch OFF to ON after the normal power supply.

How to Perform Trouble Diagnosis for Quick and Accurate Repair

INFOID:000000004407069

CVT

INTRODUCTION

The TCM receives a signal from the vehicle speed sensor, PNP switch and provides shift control or lock-up control via CVT solenoid valves.

The TCM also communicates with the ECM by means of a signal sent from sensing elements used with the OBD-related parts of the CVT system for malfunction-diagnostic purposes. The TCM is capable of diagnosing malfunctioning parts while the ECM can store malfunctions in its memory.

Input and output signals must always be correct and stable in the operation of the CVT system. The CVT system must be in good operating condition and be free of valve seizure, solenoid valve malfunction, etc.

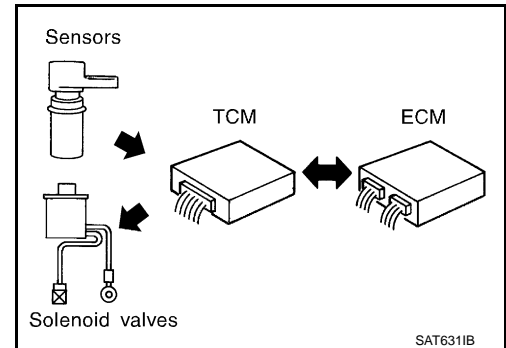

It is much more difficult to diagnose an error that occurs intermittently rather than continuously. Most intermittent errors are caused by poor electric connections or improper wiring. In this case, careful checking of suspected circuits may help prevent the replacement of good parts.

A visual check only may not find the cause of the errors. A road test with CONSULT-III (or GST) or a circuit tester connected should be performed. Follow the "WORK FLOW" .

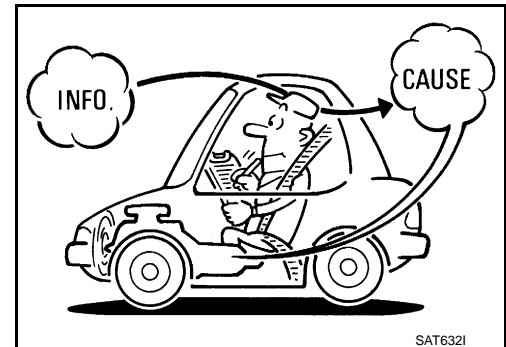

Before undertaking actual checks, take a few minutes to talk with a customer who approaches with a driveability complaint. The customer can supply good information about such errors, especially intermittent ones. Find out what symptoms are present and under what conditions they occur. A "DIAGNOSTIC WORKSHEET" as shown on the example (Refer to "Diagnostic Worksheet Chart") should be used.

Start your diagnosis by looking for "conventional" errors first. This will help troubleshoot driveability errors on an electronically controlled engine vehicle.

Also check related Service bulletins.

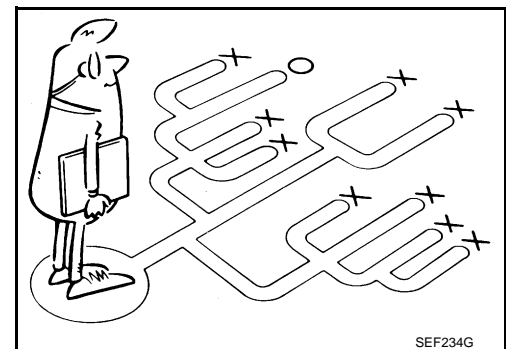

WORK FLOW

A good understanding of the malfunction conditions can make troubleshooting faster and more accurate. In general, each customer feels differently about a malfunction. It is important to fully understand the symptoms or conditions for a customer complaint.

Make good use of the two sheets provided, "Information From Customer" and "Diagnostic Worksheet Chart" , to perform the best troubleshooting possible.

Work Flow Chart

TROUBLE DIAGNOSIS

< SERVICE INFORMATION >

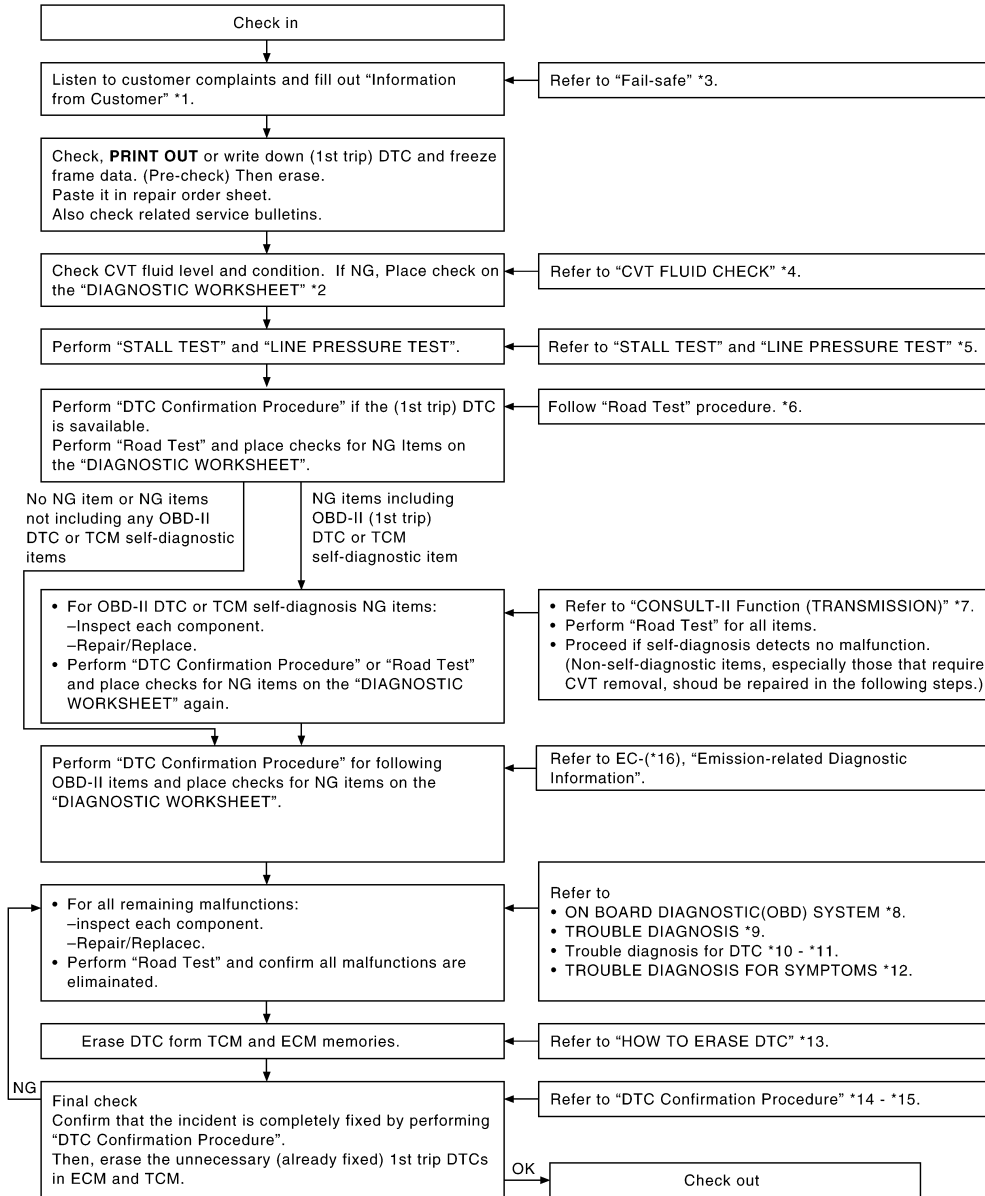

SCIA6877E

- | | | |
|---------------------------------|---|------------------------------|
| *1. "Information From Customer" | *2. "DIAGNOSTIC WORKSHEET" | *3. CVT-28 |
| *4. CVT-36 | *5. CVT-36 , CVT-36 | *6. CVT-39 |
| *7. CVT-47 | *8. CVT-25 | *9. CVT-28 |
| *10. CVT-55 | *11. CVT-139 | *12. CVT-147 |
| *13. CVT-25 | *14. CVT-55 | *15. CVT-139 |
| *16. EC-60 | | |

DIAGNOSTIC WORKSHEET

Information From Customer

KEY POINTS

- **WHAT.....** Vehicle & CVT model
- **WHEN.....** Date, Frequencies
- **WHERE.....** Road conditions
- **HOW.....** Operating conditions, Symptoms

TROUBLE DIAGNOSIS

< SERVICE INFORMATION >

Customer name MR/MS	Model & Year	VIN
Trans. Model	Engine	Mileage
malfunction Date	Manuf. Date	In Service Date
Frequency	<input type="checkbox"/> Continuous <input type="checkbox"/> Intermittent (times a day)	
Symptoms	<input type="checkbox"/> Vehicle does not move. (<input type="checkbox"/> Any position <input type="checkbox"/> Particular position)	
	<input type="checkbox"/> No shift	
	<input type="checkbox"/> Lock-up malfunction	
	<input type="checkbox"/> Shift shock or slip (<input type="checkbox"/> N → D <input type="checkbox"/> N → R <input type="checkbox"/> Lock-up <input type="checkbox"/> Any drive position)	
	<input type="checkbox"/> Noise or vibration	
	<input type="checkbox"/> No pattern select	
	<input type="checkbox"/> Others ()	
Malfunction indicator lamp (MIL)	<input type="checkbox"/> Continuously lit	<input type="checkbox"/> Not lit

Diagnostic Worksheet Chart

1	<input type="checkbox"/> Read the item on cautions concerning fail-safe and understand the customer's complaint.	CVT-28						
2	<input type="checkbox"/> CVT fluid inspection	CVT-36						
	<input type="checkbox"/> Leak (Repair leak location.) <input type="checkbox"/> State <input type="checkbox"/> Amount							
3	<input type="checkbox"/> Stall test and line pressure test	CVT-36, CVT-36						
	<input type="checkbox"/> Stall test							
	<table style="width: 100%; border: none;"> <tr> <td style="border: none;"><input type="checkbox"/> Torque converter one-way clutch</td> <td style="border: none;"><input type="checkbox"/> Engine</td> </tr> <tr> <td style="border: none;"><input type="checkbox"/> Reverse brake</td> <td style="border: none;"><input type="checkbox"/> Line pressure low</td> </tr> <tr> <td style="border: none;"><input type="checkbox"/> Forward clutch</td> <td style="border: none;"><input type="checkbox"/> Primary pulley</td> </tr> <tr> <td style="border: none;"><input type="checkbox"/> Steel belt</td> <td style="border: none;"><input type="checkbox"/> Secondary pulley</td> </tr> </table>		<input type="checkbox"/> Torque converter one-way clutch	<input type="checkbox"/> Engine	<input type="checkbox"/> Reverse brake	<input type="checkbox"/> Line pressure low	<input type="checkbox"/> Forward clutch	<input type="checkbox"/> Primary pulley
<input type="checkbox"/> Torque converter one-way clutch	<input type="checkbox"/> Engine							
<input type="checkbox"/> Reverse brake	<input type="checkbox"/> Line pressure low							
<input type="checkbox"/> Forward clutch	<input type="checkbox"/> Primary pulley							
<input type="checkbox"/> Steel belt	<input type="checkbox"/> Secondary pulley							
<input type="checkbox"/> Line pressure inspection - Suspected part:								

TROUBLE DIAGNOSIS

< SERVICE INFORMATION >

	<input type="checkbox"/> Perform road test.	CVT-39	
4	4-1.	<p>Check before engine is started</p> <p><input type="checkbox"/> CVT-150. "O/D OFF Indicator Lamp Does Not Come On"</p> <p><input type="checkbox"/> Perform self-diagnosis. Enter checks for detected items. CVT-47</p> <ul style="list-style-type: none"> <input type="checkbox"/> CVT-55 <input type="checkbox"/> CVT-58 <input type="checkbox"/> CVT-59 <input type="checkbox"/> CVT-61 <input type="checkbox"/> CVT-66 <input type="checkbox"/> CVT-71 <input type="checkbox"/> CVT-76 <input type="checkbox"/> CVT-81 <input type="checkbox"/> CVT-83 <input type="checkbox"/> CVT-84 <input type="checkbox"/> CVT-89 <input type="checkbox"/> CVT-91 <input type="checkbox"/> CVT-96 <input type="checkbox"/> CVT-98 <input type="checkbox"/> CVT-100 <input type="checkbox"/> CVT-105 <input type="checkbox"/> CVT-110 <input type="checkbox"/> CVT-114 <input type="checkbox"/> CVT-116 <input type="checkbox"/> CVT-118 <input type="checkbox"/> CVT-122 <input type="checkbox"/> CVT-124 <input type="checkbox"/> CVT-126 <input type="checkbox"/> CVT-128 <input type="checkbox"/> CVT-129 <input type="checkbox"/> CVT-135 <input type="checkbox"/> CVT-139 	CVT-40
	4-2.	<p>Check at idle</p> <p><input type="checkbox"/> CVT-152. "Engine Cannot Be Started in "P" or "N" Position"</p> <p><input type="checkbox"/> CVT-152. "In "P" Position, Vehicle Moves Forward or Backward When Pushed"</p> <p><input type="checkbox"/> CVT-153. "In "N" Position, Vehicle Moves"</p> <p><input type="checkbox"/> CVT-153. "Large Shock "N" /E "R" Position"</p> <p><input type="checkbox"/> CVT-154. "Vehicle Does Not Creep Backward in "R" Position"</p> <p><input type="checkbox"/> CVT-155. "Vehicle Does Not Creep Forward in "D" or "L" Position"</p>	CVT-40

TROUBLE DIAGNOSIS

< SERVICE INFORMATION >

4	4-3.	<p>Cruise test</p> <p> <input type="checkbox"/> CVT-156. "Vehicle Speed Does Not Change in "L" Position" <input type="checkbox"/> CVT-157. "Vehicle Speed Does Not Change in overdrive-off mode" <input type="checkbox"/> CVT-158. "Vehicle Speed Does Not Change in "D" Position" <input type="checkbox"/> CVT-158. "Cannot Be Changed to Manual Mode" <input type="checkbox"/> CVT-159. "CVT Does Not Shift in Manual Mode" <input type="checkbox"/> CVT-160. "Vehicle Does Not Decelerate by Engine Brake" <input type="checkbox"/> perform self-diagnosis. Enter checks for detected items. CVT-47 </p> <p> <input type="checkbox"/> CVT-55 <input type="checkbox"/> CVT-58 <input type="checkbox"/> CVT-59 <input type="checkbox"/> CVT-61 <input type="checkbox"/> CVT-66 <input type="checkbox"/> CVT-71 <input type="checkbox"/> CVT-76 <input type="checkbox"/> CVT-81 <input type="checkbox"/> CVT-83 <input type="checkbox"/> CVT-84 <input type="checkbox"/> CVT-89 <input type="checkbox"/> CVT-91 <input type="checkbox"/> CVT-96 <input type="checkbox"/> CVT-98 <input type="checkbox"/> CVT-100 <input type="checkbox"/> CVT-105 <input type="checkbox"/> CVT-110 <input type="checkbox"/> CVT-114 <input type="checkbox"/> CVT-116 <input type="checkbox"/> CVT-118 <input type="checkbox"/> CVT-122 <input type="checkbox"/> CVT-124 <input type="checkbox"/> CVT-126 <input type="checkbox"/> CVT-128 <input type="checkbox"/> CVT-129 <input type="checkbox"/> CVT-135 <input type="checkbox"/> CVT-139 </p>	CVT-41
5		<input type="checkbox"/> Inspect each system for items found to be NG in the self-diagnosis and repair or replace the malfunctioning parts.	
6		<input type="checkbox"/> Perform all road tests and enter the checks again for the required items.	CVT-39
7		<input type="checkbox"/> For any remaining NG items, perform the "diagnosis procedure" and repair or replace the malfunctioning parts.	
8		<input type="checkbox"/> Erase the results of the self-diagnosis from the TCM.	CVT-25 , CVT-25

A
B
CVT
D
E
F
G
H
I
J
K
L
M
N
O
P

TROUBLE DIAGNOSIS

< SERVICE INFORMATION >

CVT Electrical Parts Location

INFOID:000000004407070

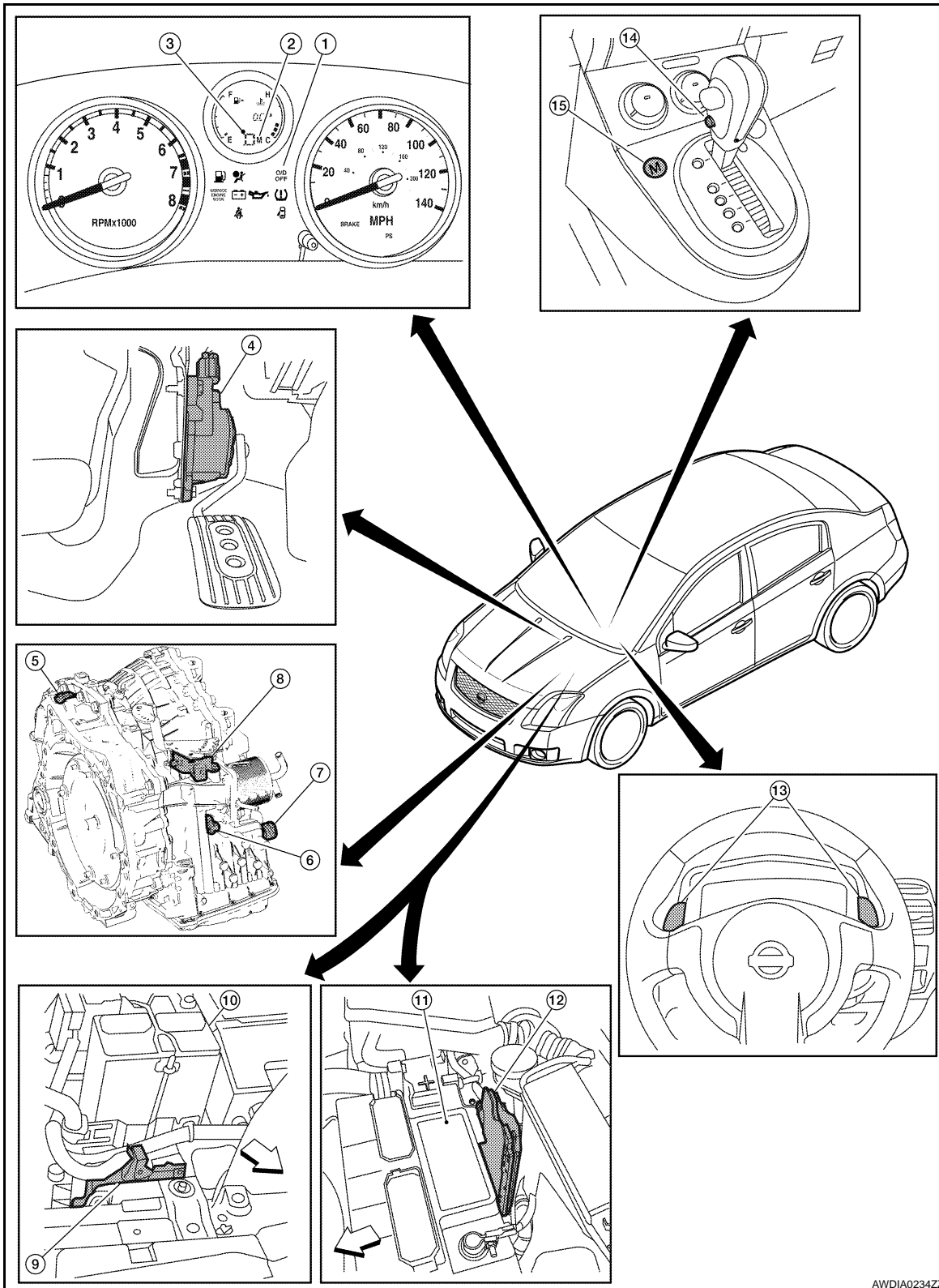

AWDIA0234ZZ

⇐: Front

- | | | |
|--|--|-----------------------------|
| 1. Overdrive indicator lamp | 2. Manual mode indicator (with QR25DE) | 3. Shift position indicator |
| 4. Accelerator pedal position (APP) sensor | 5. Secondary speed sensor | 6. Primary speed sensor |

TROUBLE DIAGNOSIS

< SERVICE INFORMATION >

- | | | |
|---|--------------------------|--------------------------------------|
| 7. CVT unit harness connector | 8. PNP switch | 9. TCM (with MR20DE) |
| 10. Battery | 11. Battery | 12. TCM (with QR25DE) |
| 13. Steering shift switch (with QR25DE) | 14. Overdrive OFF switch | 15. Manual mode switch (with QR25DE) |

Circuit Diagram

INFOID:000000004407071

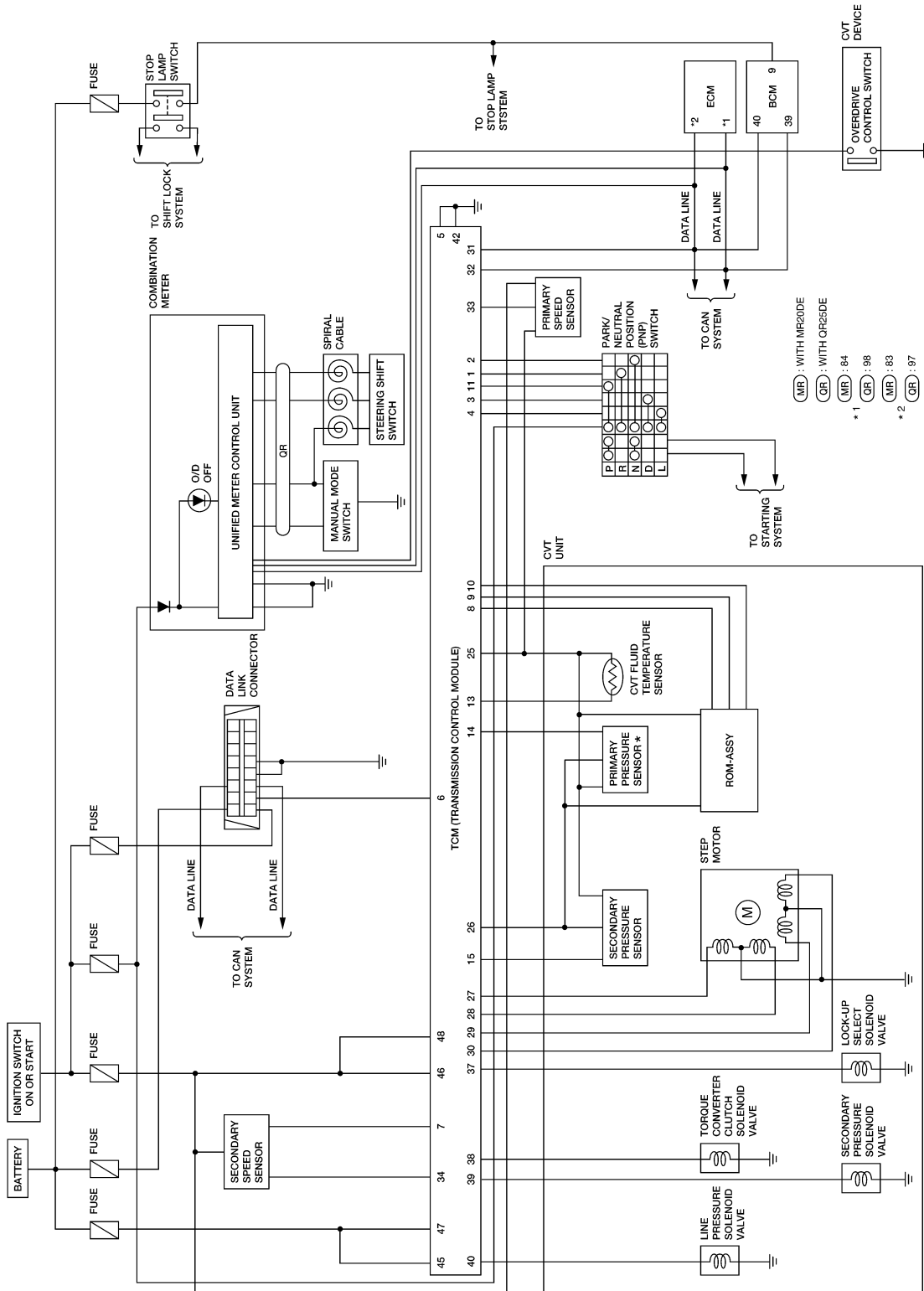

*: PRIMARY PRESSURE SENSOR DOES NOT HAVE ANY FUNCTION.

AADWA0041G6

TROUBLE DIAGNOSIS

< SERVICE INFORMATION >

Inspections before Trouble Diagnosis

INFOID:000000004407072

CVT FLUID CHECK

Fluid Leakage and Fluid Level Check

- Inspect for fluid leakage and check the fluid level. Refer to [CVT-15. "Checking CVT Fluid"](#) .

Fluid Condition Check

Inspect the fluid condition.

Fluid status	Conceivable cause	Required operation
Varnished (viscous varnish state)	Clutch, brake scorched	Replace the CVT fluid and check the CVT main unit and the vehicle for malfunctions (wire harnesses, cooler pipes, etc.)
Milky white or cloudy	Water in the fluid	Replace the CVT fluid and check for places where water is getting in.
Large amount of metal powder mixed in	Unusual wear of sliding parts within CVT	Replace the CVT fluid and check for improper operation of the CVT.

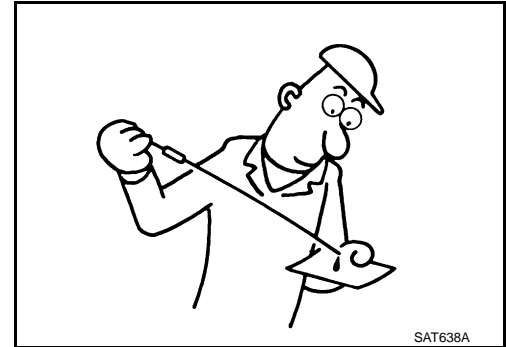

STALL TEST

Stall Test Procedure

1. Inspect the amount of engine oil. Replenish the engine oil if necessary.
2. Drive for about 10 minutes to warm up the vehicle so that the CVT fluid temperature is 50 to 80°C (122 to 176°F). Inspect the amount of CVT fluid. Replenish if necessary.

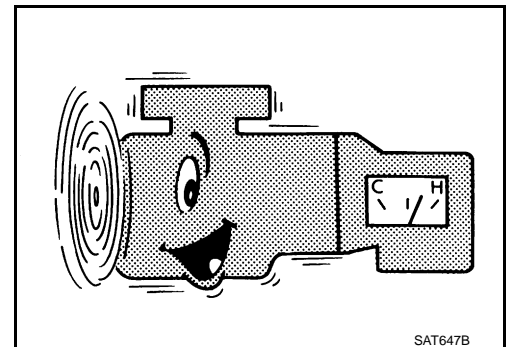

3. Securely engage the parking brake so that the tires do not turn.
4. Install a tachometer where it can be seen by driver during test.
 - It is good practice to mark the point of specified engine rpm on indicator.

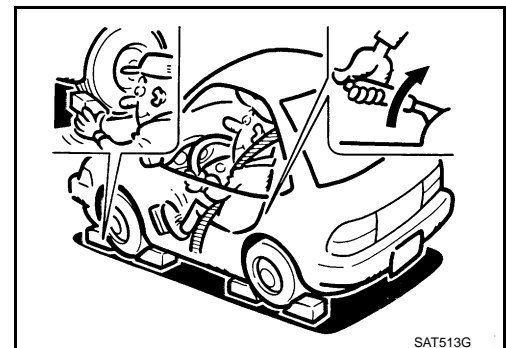

TROUBLE DIAGNOSIS

< SERVICE INFORMATION >

5. Start engine, apply foot brake, and place selector lever in "D" position.

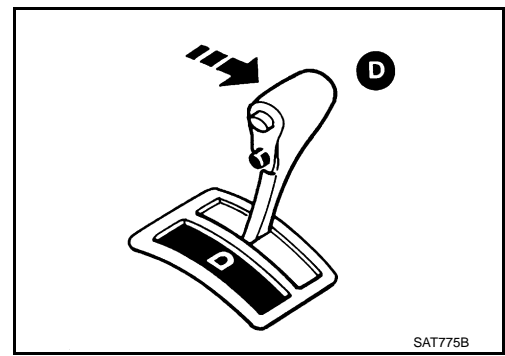

6. While holding down the foot brake, gradually press down the accelerator pedal.
7. Quickly read off the stall speed, and then quickly remove your foot from the accelerator pedal.

CAUTION:

Do not hold down the accelerator pedal for more than 5 seconds during this test.

Stall speed: 2,500 - 3,000 rpm (with MR20DE)

Stall speed: 2,050 - 3,550 rpm (with QR25DE)

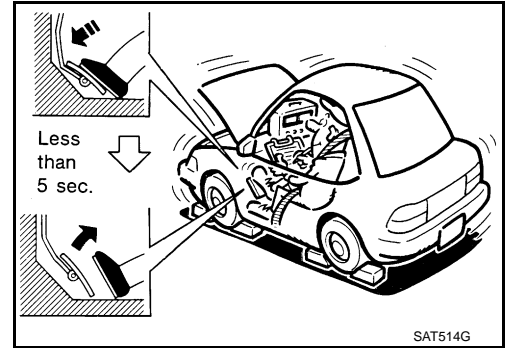

8. Move the selector lever to the "N" position.
9. Cool down the CVT fluid.
CAUTION:
Run the engine at idle for at least 1 minute.
10. Repeat steps 6 through 9 with selector lever in "R" position.

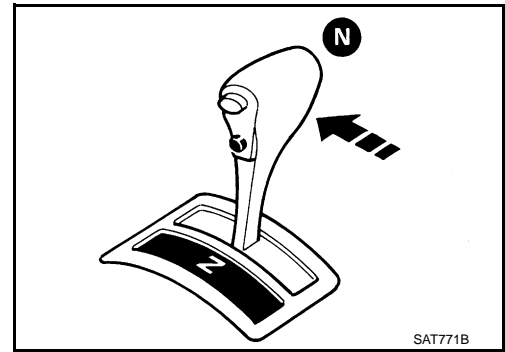

Judgment Stall Test

	Selector lever position		Expected problem location
	"D", "L"	"R"	
Stall rotation	H	O	• Forward clutch
	O	H	• Reverse brake
	L	L	• Engine and torque converter one-way clutch
	H	H	• Line pressure low • Primary pulley • Secondary pulley • Steel belt

O: Stall speed within standard value position.

H: Stall speed is higher than standard value.

L: Stall speed is lower than standard value.

LINE PRESSURE TEST

Line Pressure Test Port

TROUBLE DIAGNOSIS

< SERVICE INFORMATION >

(A): Line pressure Test Port.

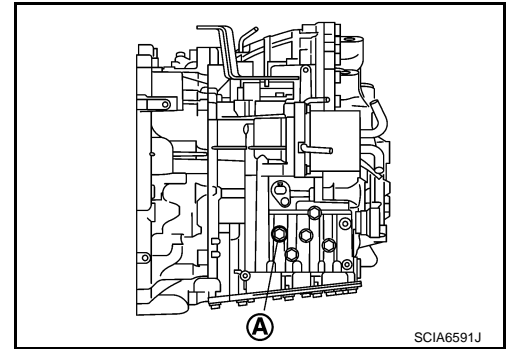

Line Pressure Test Procedure

1. Inspect the amount of engine oil and replenish if necessary.
2. Drive the car for about 10 minutes to warm it up so that the CVT fluid reaches in the range of 50 to 80°C (122 to 176°F), then inspect the amount of CVT fluid and replenish if necessary.

NOTE:

The CVT fluid temperature rises in the range of 50 - 80°C (122 - 176°F) during 10 minutes of driving.

3. After warming up CVT, remove the oil pressure detection plug and install the oil pressure gauge [special service tool: - (OTC3492)]

CAUTION:

When using the oil pressure gauge, be sure to use the O-ring attached to the oil pressure detection plug.

4. Securely engage the parking brake so that the tires do not turn.

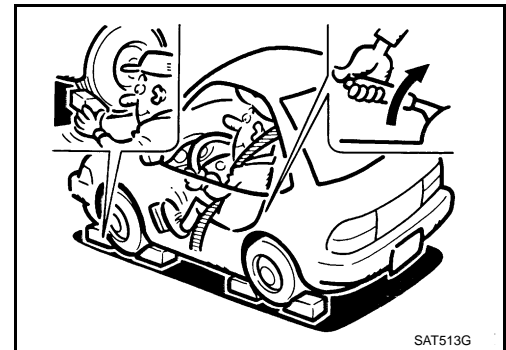

5. Start the engine, and then measure the line pressure at both idle and the stall speed.

CAUTION:

- Keep the brake pedal pressed all the way down during measurement.
- When measuring the line pressure at the stall speed, refer to "STALL TEST" .

6. After the measurements are complete, install the oil pressure detection plug and tighten to the specified torque below.

 : 7.5 N·m (0.77 kg·m, 66 in·lb)

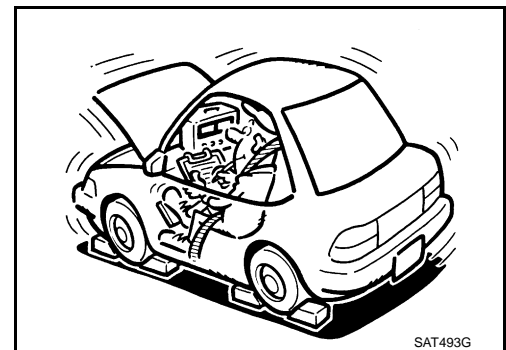

CAUTION:

- Do not reuse O-ring.
- Apply CVT fluid to O-ring.

Line Pressure

Engine speed	Line pressure kPa (kg/cm ² , psi)
	"R", "D", "L" positions
At idle	750 (7.65, 108.8)
At stall	5,700 (58.14, 826.5)*

*: Reference values

TROUBLE DIAGNOSIS

< SERVICE INFORMATION >

Judgment of Line Pressure Test

Judgment		Possible cause
Idle speed	Low for all positions ("P", "R", "N", "D", "L")	Possible causes include malfunctions in the pressure supply system and low oil pump output. For example <ul style="list-style-type: none"> • Oil pump wear • Pressure regulator valve or plug sticking or spring fatigue • Oil strainer ⇒ oil pump ⇒ pressure regulator valve passage oil leak • Engine idle speed too low
	Only low for a specific position	Possible causes include an oil pressure leak in a passage or device related to the position after the pressure is distributed by the manual valve.
	High	Possible causes include a sensor malfunction or malfunction in the line pressure adjustment function. For example <ul style="list-style-type: none"> • Accelerator pedal position signal malfunction • CVT fluid temperature sensor malfunction • Pressure control solenoid A (line pressure solenoid) malfunction (sticking in OFF state, filter clog, cut line) • Pressure regulator valve or plug sticking
Stall speed	Line pressure does not rise higher than the line pressure for idle.	Possible causes include a sensor malfunction or malfunction in the pressure adjustment function. For example <ul style="list-style-type: none"> • Accelerator pedal position signal malfunction • TCM malfunction • Pressure control solenoid A (line pressure solenoid) malfunction (shorting, sticking in ON state) • Pressure regulator valve or plug sticking
	The pressure rises, but does not enter the standard position.	Possible causes include malfunctions in the pressure supply system and malfunction in the pressure adjustment function. For example <ul style="list-style-type: none"> • Accelerator pedal position signal malfunction • Pressure control solenoid A (line pressure solenoid) malfunction (sticking, filter clog) • Pressure regulator valve or plug sticking
	Only low for a specific position	Possible causes include an oil pressure leak in a passage or device related to the position after the pressure is distributed by the manual valve.

Road Test

INFOID:000000004407073

DESCRIPTION

- The purpose of the test is to determine overall performance of CVT and analyze causes of problems.
- The road test consists of the following three parts:
 1. "Check Before Engine Is Started"[CVT-40](#) .
 2. "Check at Idle"[CVT-40](#) .
 3. "Cruise Test"[CVT-41](#) .

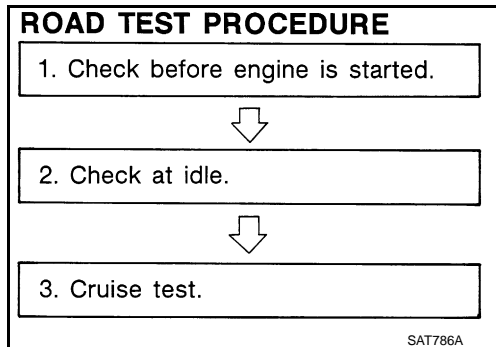

TROUBLE DIAGNOSIS

< SERVICE INFORMATION >

- Before road test, familiarize yourself with all test procedures and items to check.
- Perform tests on all items until specified symptom is found. Troubleshoot items which check out No Good after road test.

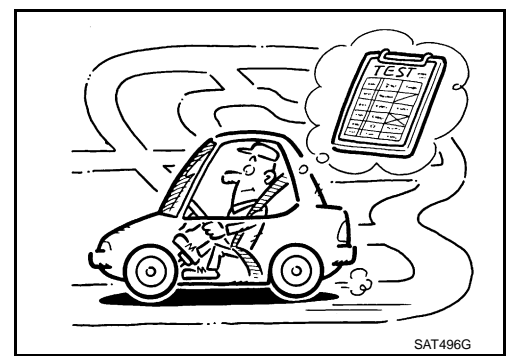

CONSULT-III OPERATION PROCEDURE

CAUTION:

If CONSULT-III is used with no connection of CONSULT-III CONVERTER, malfunctions might be detected in self-diagnosis depending on control unit which performs CAN communication.

- Using CONSULT-III, perform a cruise test and record the result.
 - Print the result and ensure that shifts and lock-ups take place as per Shift Schedule.
1. Touch "DATA MONITOR" on "SELECT DIAG MODE" screen.
 2. Touch "MAIN SIGNALS" to set recording condition.
 3. See "Numerical Display", "Barchart Display" or "Line Graph Display".
 4. Touch "START".
 5. When performing cruise test. Refer to [CVT-41, "Cruise Test"](#) .
 6. After finishing cruise test part, touch "RECORD".
 7. Touch "STORE".
 8. Touch "BACK".
 9. Touch "DISPLAY".
 10. Touch "PRINT".
 11. Check the monitor data printed out.

Check before Engine Is Started

INFOID:000000004407074

1. CHECK O/D OFF INDICATOR LAMP

1. Park vehicle on flat surface.
2. Move selector lever to "P" position.
3. Turn ignition switch OFF. Wait at least 5 seconds.
4. Turn ignition switch ON. (Do not start engine.)

Does O/D OFF indicator lamp come on for about 2 seconds?

- YES >> 1. Turn ignition switch OFF.
2. Perform self-diagnosis and note NG items.
Refer to [CVT-47, "CONSULT-III Function \(TRANSMISSION\)"](#) .
3. Go to [CVT-40, "Check at Idle"](#) .
- NO >> Stop "Road Test". Go to [CVT-150, "O/D OFF Indicator Lamp Does Not Come On"](#) .

Check at Idle

INFOID:000000004407075

1. CHECK STARTING THE ENGINE

1. Park vehicle on flat surface.
2. Move selector lever to "P" or "N" position.
3. Turn ignition switch OFF.
4. Turn ignition switch START.

Is engine started?

- YES >> GO TO 2.
- NO >> Stop "Road Test". Mark the box on the [CVT-152, "Engine Cannot Be Started in "P" or "N" Position"](#) on the [CVT-29, "How to Perform Trouble Diagnosis for Quick and Accurate Repair"](#). Go to [CVT-152, "Engine Cannot Be Started in "P" or "N" Position"](#).

TROUBLE DIAGNOSIS

< SERVICE INFORMATION >

2.CHECK STARTING THE ENGINE

1. Turn ignition switch ON.
2. Move selector lever to "R", "D" or "L" position.
3. Turn ignition switch START.

Is engine started?

YES >> Stop "Road Test". Mark the box on the [CVT-152, "Engine Cannot Be Started in "P" or "N" Position"](#) on the [CVT-29, "How to Perform Trouble Diagnosis for Quick and Accurate Repair"](#). Go to [CVT-152, "Engine Cannot Be Started in "P" or "N" Position"](#).

NO >> GO TO 3.

3.CHECK "P" POSITION FUNCTION

1. Move selector lever to "P" position.
2. Turn ignition switch OFF.
3. Release parking brake.
4. Push vehicle forward or backward.
5. Apply parking brake.

Does vehicle move when it is pushed forward or backward?

YES >> Mark the box [CVT-152, "In "P" Position, Vehicle Moves Forward or Backward When Pushed"](#) on the [CVT-29, "How to Perform Trouble Diagnosis for Quick and Accurate Repair"](#). Continue "Road Test".

NO >> GO TO 4.

4.CHECK "N" POSITION FUNCTION

1. Start engine.
2. Move selector lever to "N" position.
3. Release parking brake.

Does vehicle move forward or backward?

YES >> Mark the box [CVT-153, "In "N" Position, Vehicle Moves"](#) on the [CVT-29, "How to Perform Trouble Diagnosis for Quick and Accurate Repair"](#). Continue "Road Test".

NO >> GO TO 5.

5.CHECK SHIFT SHOCK

1. Apply foot brake.
2. Move selector lever to "R" position.

Is there large shock when changing from "N" to "R" position?

YES >> Mark the box [CVT-153, "Large Shock "N" Æ "R" Position"](#) on the [CVT-29, "How to Perform Trouble Diagnosis for Quick and Accurate Repair"](#). Continue "Road Test".

NO >> GO TO 6.

6.CHECK "R" POSITION FUNCTION

Release foot brake for several seconds.

Does vehicle creep backward when foot brake is released?

YES >> GO TO 7.

NO >> Mark the box [CVT-154, "Vehicle Does Not Creep Backward in "R" Position"](#) on the [CVT-29, "How to Perform Trouble Diagnosis for Quick and Accurate Repair"](#). Continue "Road Test".

7.CHECK "D", "L" POSITIONS FUNCTION

Move selector lever to "D" and "L" positions and check if vehicle creeps forward.

Does vehicle creep forward in all positions?

YES >> Go to [CVT-41, "Cruise Test"](#).

NO >> Stop "Road Test". Mark the box [CVT-155, "Vehicle Does Not Creep Forward in "D" or "L" Position"](#) on the [CVT-29, "How to Perform Trouble Diagnosis for Quick and Accurate Repair"](#). Go to [CVT-155, "Vehicle Does Not Creep Forward in "D" or "L" Position"](#).

Cruise Test

INFOID:000000004407076

1.CHECK VEHICLE SPEED WHEN SHIFTING GEARS — PART 1

TROUBLE DIAGNOSIS

< SERVICE INFORMATION >

1. Drive vehicle for approximately 10 minutes to warm engine oil and CVT fluid up to operating temperature.

CVT fluid operating temperature: 50 - 80°C (122 - 176°F)

2. Park vehicle on flat surface.
3. Move selector lever to "P" position.
4. Start engine.
5. Move selector lever to "L" position.
6. Accelerate vehicle to 2/8-way throttle depressing accelerator pedal constantly.

Ⓟ Read vehicle speed and engine speed. Refer to [CVT-44, "Vehicle Speed When Shifting Gears"](#).

OK or NG

- OK >> GO TO 2.
NG >> Mark the box [CVT-156, "Vehicle Speed Does Not Change in "L" Position"](#) on the [CVT-29, "How to Perform Trouble Diagnosis for Quick and Accurate Repair"](#). Continue "Road Test".

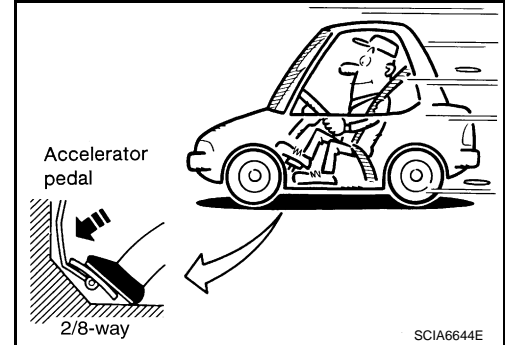

2.CHECK VEHICLE SPEED WHEN SHIFTING GEARS — PART 2

1. Park vehicle on flat surface.
2. Move selector lever to "D" position.
3. Accelerate vehicle to full depression depressing accelerator pedal constantly.

Ⓟ Read vehicle speed and engine speed. Refer to [CVT-44, "Vehicle Speed When Shifting Gears"](#).

OK or NG

- OK >> GO TO 3. (With manual mode)
OK >> GO TO 7. (Without manual mode)
NG >> Mark the box [CVT-159, "CVT Does Not Shift in Manual Mode"](#) on the [CVT-29, "How to Perform Trouble Diagnosis for Quick and Accurate Repair"](#). Continue "Road Test".

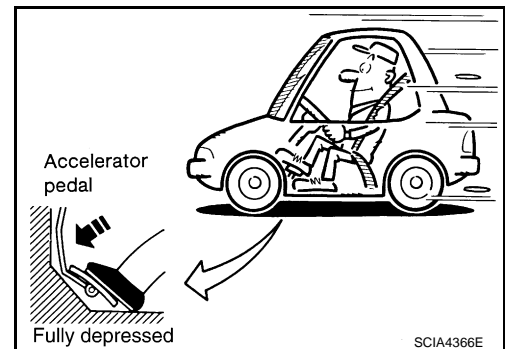

3.CHECK MANUAL MODE FUNCTION

Move to manual mode from "D" position.

Does it switch to manual mode?

- YES >> GO TO 4.
NO >> Mark the box [CVT-158, "Cannot Be Changed to Manual Mode"](#) on the [CVT-29, "How to Perform Trouble Diagnosis for Quick and Accurate Repair"](#). Continue "Road Test".

4.CHECK SHIFT-UP FUNCTION

During manual mode driving, is upshift from M1 → M2 → M3 → M4 → M5 → M6 performed?

Ⓟ Read the gear position. Refer to [CVT-47, "CONSULT-III Function \(TRANSMISSION\)"](#).

Is upshifting correctly performed?

- YES >> GO TO 5.
NO >> Mark the box [CVT-159, "CVT Does Not Shift in Manual Mode"](#) on the [CVT-29, "How to Perform Trouble Diagnosis for Quick and Accurate Repair"](#). Continue "Road Test".

5.CHECK SHIFT-DOWN FUNCTION

During manual mode driving, is downshift from M6 → M5 → M4 → M3 → M2 → M1 performed?

Ⓟ Read the gear position. Refer to [CVT-47, "CONSULT-III Function \(TRANSMISSION\)"](#).

Is downshifting correctly performed?

- YES >> GO TO 6.
NO >> Mark the box [CVT-159, "CVT Does Not Shift in Manual Mode"](#) on the [CVT-29, "How to Perform Trouble Diagnosis for Quick and Accurate Repair"](#). Continue "Road Test".

TROUBLE DIAGNOSIS

< SERVICE INFORMATION >

6. CHECK ENGINE BRAKE FUNCTION

Check engine brake.

Does engine braking effectively reduce speed in M1 position?

- YES >> 1. Stop the vehicle.
2. Perform self-diagnosis. Refer to [CVT-47, "CONSULT-III Function \(TRANSMISSION\)"](#).
- NO >> Mark the box of [CVT-160, "Vehicle Does Not Decelerate by Engine Brake"](#) on the [CVT-29, "How to Perform Trouble Diagnosis for Quick and Accurate Repair"](#). Then continue trouble diagnosis.

7. CHECK VEHICLE SPEED WHEN SHIFTING GEARS — PART 2

1. Park vehicle on flat surface.
2. Move selector lever to "D" position.
3. Push overdrive control switch. (O/D OFF indicator lamp is on.)
4. Accelerate vehicle to 2/8-way throttle depressing accelerator pedal constantly.

 Read vehicle speed and engine speed. Refer to [CVT-44, "Vehicle Speed When Shifting Gears"](#).

OK or NG

- OK >> GO TO 8.
- NG >> Mark the box [CVT-157, "Vehicle Speed Does Not Change in overdrive-off mode"](#) on the [CVT-29, "How to Perform Trouble Diagnosis for Quick and Accurate Repair"](#). Continue "Road Test".

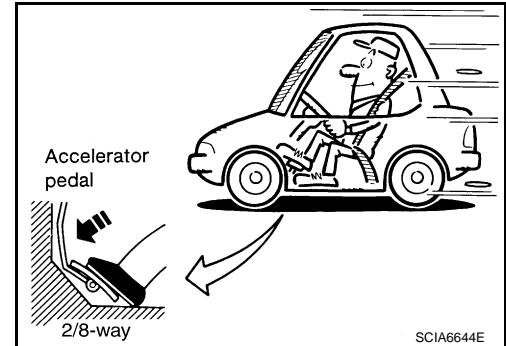

8. CHECK VEHICLE SPEED WHEN SHIFTING GEARS — PART 3

1. Park vehicle on flat surface.
2. Move selector lever to "D" position.
3. Push overdrive control switch. (O/D OFF indicator lamp is off.)
4. Accelerate vehicle to 2/8 way throttle depressing accelerator pedal constantly.

 Read vehicle speed and engine speed. Refer to [CVT-44, "Vehicle Speed When Shifting Gears"](#).

OK or NG

- OK >> GO TO 9.
- NG >> Mark the box [CVT-158, "Vehicle Speed Does Not Change in "D" Position"](#) on the [CVT-29, "How to Perform Trouble Diagnosis for Quick and Accurate Repair"](#). Continue "Road Test".

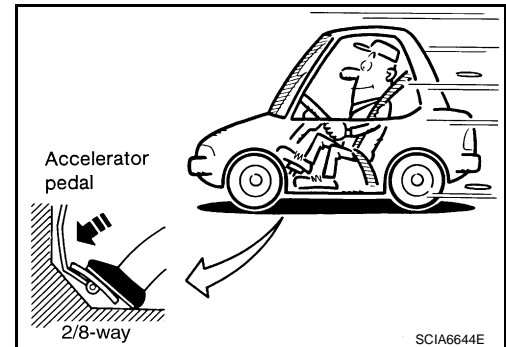

9. CHECK VEHICLE SPEED WHEN SHIFTING GEARS — PART 4

1. Park vehicle on flat surface.
2. Move selector lever to "L" position.
3. Accelerate vehicle to full depression depressing accelerator pedal constantly.

 Read vehicle speed and engine speed. Refer to [CVT-44, "Vehicle Speed When Shifting Gears"](#).

OK or NG

- OK >> GO TO 10.
- NG >> Mark the box [CVT-156, "Vehicle Speed Does Not Change in "L" Position"](#) on the [CVT-29, "How to Perform Trouble Diagnosis for Quick and Accurate Repair"](#). Continue "Road Test".

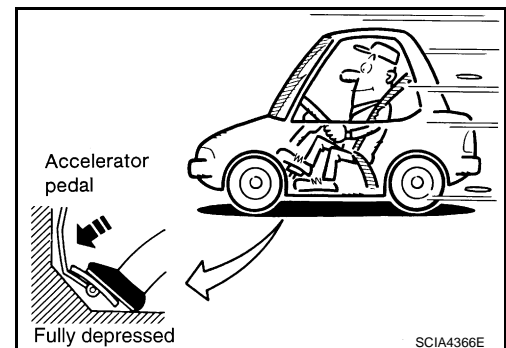

10. CHECK VEHICLE SPEED WHEN SHIFTING GEARS — PART 5

1. Park vehicle on flat surface.
2. Move selector lever to "D" position.

A
B
CVT
D
E
F
G
H
I
J
K
L
M
N
O
P

TROUBLE DIAGNOSIS

< SERVICE INFORMATION >

3. Push overdrive control switch. (O/D OFF indicator lamp is on.)
4. Accelerate vehicle to full depression depressing accelerator pedal constantly.

④ Read vehicle speed and engine speed. Refer to [CVT-44, "Vehicle Speed When Shifting Gears"](#).

OK or NG

OK >> GO TO 11.

NG >> Mark the box [CVT-157, "Vehicle Speed Does Not Change in overdrive-off mode"](#) on the [CVT-29, "How to Perform Trouble Diagnosis for Quick and Accurate Repair"](#). Continue "Road Test".

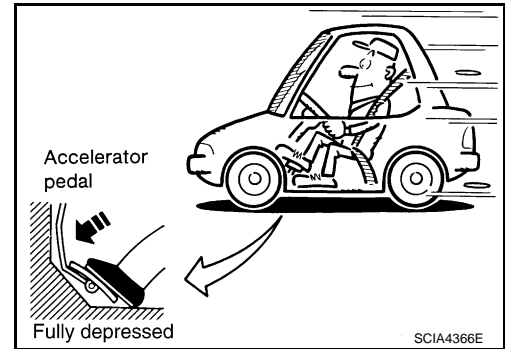

11. CHECK VEHICLE SPEED WHEN SHIFTING GEARS — PART 6

1. Park vehicle on flat surface.
2. Move selector lever to "D" position.
3. Push overdrive control switch. (O/D OFF indicator lamp is off.)
4. Accelerate vehicle to full depression depressing accelerator pedal constantly.

④ Read vehicle speed and engine speed. Refer to [CVT-44, "Vehicle Speed When Shifting Gears"](#).

OK or NG

OK >> GO TO 12.

NG >> Mark the box [CVT-158, "Vehicle Speed Does Not Change in "D" Position"](#) on the [CVT-29, "How to Perform Trouble Diagnosis for Quick and Accurate Repair"](#). Continue "Road Test".

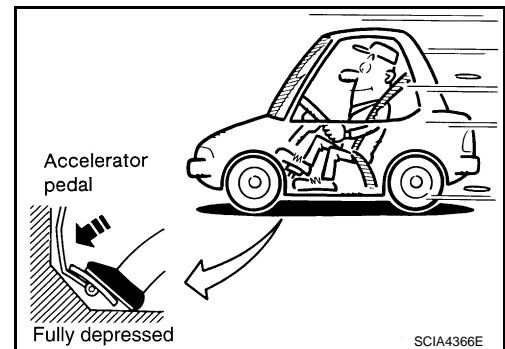

12. CHECK ENGINE BRAKE FUNCTION — PART 1

1. Release accelerator pedal.
2. Check engine brake. (O/D OFF indicator lamp is off.)

Does engine braking effectively reduce speed in "D" position?

YES >> GO TO 13.

NO >> Mark the box [CVT-160, "Vehicle Does Not Decelerate by Engine Brake"](#) on the [CVT-29, "How to Perform Trouble Diagnosis for Quick and Accurate Repair"](#). Continue "Road Test".

13. CHECK ENGINE BRAKE FUNCTION — PART 2

1. Push overdrive control switch. (O/D OFF indicator lamp is on.)
2. Check engine brake.

Does engine braking effectively reduce speed in "D" position?

YES >> GO TO 14.

NO >> Mark the box [CVT-160, "Vehicle Does Not Decelerate by Engine Brake"](#) on the [CVT-29, "How to Perform Trouble Diagnosis for Quick and Accurate Repair"](#). Continue "Road Test".

14. CHECK ENGINE BRAKE FUNCTION — PART 3

1. Move selector lever to "L" position.
2. Check engine brake.

Does engine braking effectively reduce speed in "L" position?

YES >> 1. Stop the vehicle.

2. Perform self-diagnosis. Refer to [CVT-47, "CONSULT-III Function \(TRANSMISSION\)"](#).

NO >> Mark the box [CVT-160, "Vehicle Does Not Decelerate by Engine Brake"](#) on the [CVT-29, "How to Perform Trouble Diagnosis for Quick and Accurate Repair"](#). Then continue trouble diagnosis.

Vehicle Speed When Shifting Gears

INFOID:000000004407077

Numerical value data are reference values.

TROUBLE DIAGNOSIS

< SERVICE INFORMATION >

Engine type	Throttle position	Shift pattern	Engine speed (rpm)	
			At 40 km/h (25 MPH)	At 60 km/h (37 MPH)
QR25DE	8/8	"D" position	3,300 - 4,200	4,300 - 5,200
		Overdrive-off mode		
		"L" position		
	2/8	"D" position	1,300 - 3,100	1,400 - 3,400
		Overdrive-off mode	2,200 - 3,000	2,800 - 3,600
		"L" position	3,200 - 4,100	4,100 - 4,900
MR20DE	8/8	"D" position	3,400 - 4,200	4,300 - 5,100
		Overdrive-off mode		
		"L" position		
	2/8	"D" position	1,400 - 2,200	1,600 - 2,400
		Overdrive-off mode	2,200 - 3,000	2,800 - 3,600
		"L" position	3,600 - 4,400	4,100 - 4,900

CAUTION:

Lock-up clutch is engaged when vehicle speed is approximately 18 km/h (11 MPH) to 90 km/h (56 MPH).

TCM Input/Output Signal Reference Value

INFOID:000000004407078

TCM HARNESS CONNECTOR TERMINAL LAYOUT

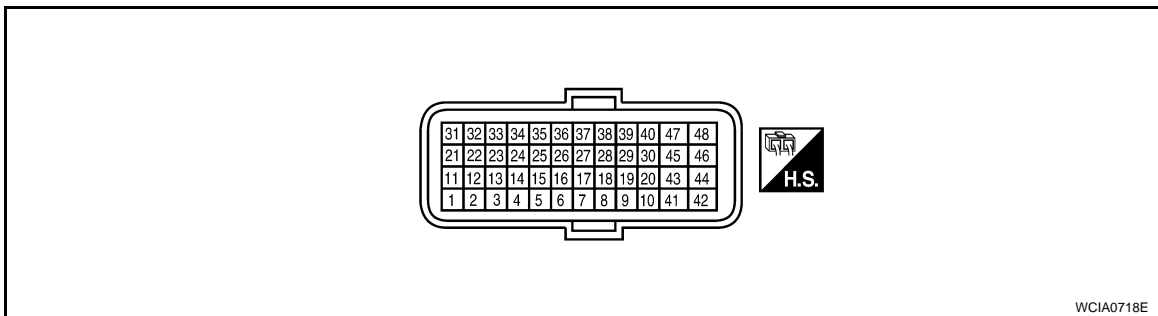











TERMINALS AND REFERENCE VALUES FOR TCM

Data are reference values and are measured between each terminal and ground.

Terminal	Wire color	Item	Condition	Data (Approx.)
1	W/B	PNP switch "R" position	Selector lever in "R" position.	Battery voltage
			When setting selector lever to other positions	0 V
2	P/B	PNP switch "N" position	Selector lever in "N" position	Battery voltage
			When setting selector lever to other positions	0 V
3	G/O	PNP switch "D" position	Selector lever in "D" position	Battery voltage
			When setting selector lever to other positions	0 V
4	GR	PNP switch "L" position	Selector lever in "L" position	Battery voltage
			When setting selector lever to other positions	0 V
5	B	Ground	Always	0 V
6	P/L	K-LINE	—	—
7	W/R	Sensor ground	Always	0 V
8	G/W	ROM assembly	—	—
9	L/R	ROM assembly	—	—
10	BR/R	ROM assembly	—	—







TROUBLE DIAGNOSIS

< SERVICE INFORMATION >

Terminal	Wire color	Item	Condition		Data (Approx.)	
11	BR/W	PNP switch "P" position		Selector lever in "P" position	Battery voltage	
				When setting selector lever to other positions	0 V	
13	V	CVT fluid temperature sensor		When CVT fluid temperature is 20°C (68°F)	2.0 V	
				When CVT fluid temperature is 80°C (176°F)	1.0 V	
14	LG	Transmission fluid pressure sensor B (Primary pressure sensor)	—	—	—	
15	V/W	Transmission fluid pressure sensor A (Secondary pressure sensor)	 and 	"N" position idle	1.0 V	
25	W/R	Sensor ground	Always		0 V	
26	L/O	Sensor power		—	5.0 V	
				—	0 V	
27	R/G	Step motor D	Within 2 seconds after ignition switch ON, the time measurement by using the pulse width measurement function (Hi level) of CONSULT-III.*1 CAUTION: Connect the diagnosis data link cable to the vehicle diagnosis connector. *1: A circuit tester cannot be used to test this item.		10.0 msec	
28	R	Step motor C			30.0 msec	
29	O/B	Step motor B			10.0 msec	
30	G/R	Step motor A			30.0 msec	
31	P	CAN-L	—		—	
32	L	CAN-H	—		—	
33	LG/R	Input speed sensor (Primary speed sensor)		When driving ["L" position, 20 km/h (12 MPH)].	890 Hz	
34	W	Output speed sensor (Secondary speed sensor)		When driving ["D" position, 20 km/h (12 MPH)].	460 Hz	
37	L/W	Lock-up select solenoid valve		Selector lever in "P" or "N" positions	Battery voltage	
				Wait at least for 5 seconds with the selector lever in "R", "D" or "L" positions	0 V	
38	G	Torque converter clutch solenoid valve		When vehicle cruises in "D" position.	When CVT performs lock-up.	6.0 V
					When CVT does not perform lock-up.	1.5 V

TROUBLE DIAGNOSIS

< SERVICE INFORMATION >

Terminal	Wire color	Item	Condition		Data (Approx.)
39	W/G	Pressure control solenoid valve B (Secondary pressure solenoid valve)		Release your foot from the accelerator pedal.	5.0 - 7.0 V
				Press the accelerator pedal all the way down.	3.0 - 4.0 V
40	R/Y	Pressure control solenoid valve A (Line pressure solenoid valve)		Release your foot from the accelerator pedal.	5.0 - 7.0 V
				Press the accelerator pedal all the way down.	1.0 V
42	B	Ground	Always		0 V
45	Y/R	Power supply (memory back-up)	Always		Battery voltage
46	Y	Power supply		—	Battery voltage
				—	0 V
47	Y/R	Power supply (memory back-up)	Always		Battery voltage
48	Y	Power supply		—	Battery voltage
				—	0 V

CONSULT-III Function (TRANSMISSION)

INFOID:000000004407079

CONSULT-III can display each diagnostic item using the diagnostic test modes shown below.

FUNCTION

Diagnostic test mode	Function
Work support	This mode enables a technician to adjust some devices faster and more accurately by following the indications on CONSULT-III.
Self-diagnostic results	Self-diagnostic results can be read and erased quickly.
Data monitor	Input/Output data in the TCM can be read.
CAN diagnostic support monitor	The results of transmit/receive diagnosis of CAN communication can be read.
CALIB data	Characteristic information for TCM and CVT assembly can be read.
Function test	Performed by CONSULT-III instead of a technician to determine whether each system is "OK" or "NG".
ECU part number	TCM part number can be read.

CONSULT-III REFERENCE VALUE

Item name	Condition	Display value (Approx.)
VSP SENSOR	During driving	Approximately matches the speedometer reading.
ESTM VSP SIG		
PRI SPEED SEN	During driving (lock-up ON)	Approximately matches the engine speed.
ENG SPEED SIG	Engine running	Closely matches the tachometer reading.

TROUBLE DIAGNOSIS

< SERVICE INFORMATION >

Item name	Condition	Display value (Approx.)
SEC HYDR SEN	"N" position idle	1.0 V
ATF TEMP SEN	When CVT fluid temperature is 20°C (68°F)	2.0 V
	When CVT fluid temperature is 80°C (176°F)	1.0 V
VIGN SEN	Ignition switch: ON	Battery voltage
VEHICLE SPEED	During driving	Approximately matches the speedometer reading.
PRI SPEED	During driving (lock-up ON)	Approximately matches the engine speed.
SEC SPEED	During driving	45 X Approximately matches the speedometer reading.
ENG SPEED	Engine running	Closely matches the tachometer reading.
GEAR RATIO	During driving	2.34 - 0.39
ACC PEDAL OPEN	Released accelerator pedal - Fully depressed accelerator pedal	0.0/8 - 8.0/8
SEC PRESS	"N" position idle	1.3 MPa
STM STEP	During driving	0 step – 177 step
ISOLT1	Lock-up "OFF"	0.0 A
	Lock-up "ON"	0.7 A
ISOLT2	Release your foot from the accelerator pedal.	0.8 A
	Press the accelerator pedal all the way down.	0.0 A
ISOLT3	Secondary pressure low - Secondary pressure high	0.8 - 0.0 A
SOLMON1	Lock-up "OFF"	0.0 A
	Lock-up "ON"	0.7 A
SOLMON2	"N" position idle	0.8 A
	When stalled	0.3 - 0.6 A
SOLMON3	"N" position idle	0.6 - 0.7 A
	When stalled	0.4 - 0.6 A
P POSITION SW	Selector lever in "P" position	ON
	When setting selector lever to other positions.	OFF
R POSITION SW	Selector lever in "R" position	ON
	When setting selector lever to other positions.	OFF
N POSITION SW	Selector lever in "N" position	ON
	When setting selector lever to other positions.	OFF
D POSITION SW	Selector lever in "D" position	ON
	When setting selector lever to other positions.	OFF
L POSITION SW	Selector lever in "L" position	ON
	When setting selector lever to other positions.	OFF
BRAKE SW	Depressed brake pedal	ON
	Released brake pedal	OFF
FULL SW	Fully depressed accelerator pedal	ON
	Released accelerator pedal	OFF
IDLE SW	Released accelerator pedal	ON
	Fully depressed accelerator pedal	OFF
SPORT MODE SW	When OD OFF indicator lamp is off.	ON
	When OD OFF indicator lamp is on.	OFF

TROUBLE DIAGNOSIS

< SERVICE INFORMATION >

Item name	Condition	Display value (Approx.)	
INDLRNG	Selector lever in "L" position	ON	A
	When setting selector lever to other positions.	OFF	
INDDRNG	Selector lever in "D" position	ON	B
	When setting selector lever to other positions.	OFF	
INDNRNG	Selector lever in "N" position	ON	CVT
	When setting selector lever to other positions.	OFF	
INDRRNG	Selector lever in "R" position	ON	
	When setting selector lever to other positions.	OFF	D
INDPRNG	Selector lever in "P" position	ON	
	When setting selector lever to other positions.	OFF	E
SPORT MODE IND	When sport mode	ON	
	Other conditions	OFF	
SMCOIL D	During driving	Changes ON ⇔ OFF.	F
SMCOIL C			
SMCOIL B			
SMCOIL A			G
LUSEL SOL OUT	Selector lever in "P", "N" positions	ON	
	Wait at least for 5 seconds with the selector lever in "R", "D" or "L" position	OFF	H
LUSEL SOL MON	Selector lever in "P", "N" positions	ON	
	Wait at least for 5 seconds with the selector lever in "R", "D" or "L" position	OFF	I
ABS ON	ABS operate	ON	
	Other conditions	OFF	J
RANGE	Selector lever in "N" or "P" position	N·P	
	Selector lever in "R" position	R	
	Selector lever in "D" position	D	K
	Selector lever in "L" position	L	

WORK SUPPORT MODE

Display Item List

Item name	Description	
ENGINE BRAKE ADJ.	The engine brake level setting can be canceled.	M
CONFORM CVTF DETERIORTN	The CVT fluid deterioration level can be checked.	N

Engine Brake Adjustment

"ENGINE BRAKE LEVEL"

0: Initial set value (Engine brake level control is activated)

OFF: Engine brake level control is deactivated.

CAUTION:

Mode of "+1" "0" "-1" "-2" "OFF" can be selected by pressing the "UP" "DOWN" on CONSULT-III screen. However, do not select mode other than "0" and "OFF". If the "+1" or "-1" or "-2" is selected, that might cause the irregular driveability.

Check CVT Fluid Deterioration Date

TROUBLE DIAGNOSIS

< SERVICE INFORMATION >

“CVTF DETERIORATION DATE”

More than 210000:

It is necessary to change CVT fluid.

Less than 210000:

It is not necessary to change CVT fluid.

CAUTION:

Touch “CLEAR” after changing CVT fluid, and then erase “CVTF DETERIORATION DATE”.

SELF-DIAGNOSTIC RESULT MODE

After performing self-diagnosis, place check marks for results on the [CVT-29, "How to Perform Trouble Diagnosis for Quick and Accurate Repair"](#). Reference pages are provided following the items.

Display Items List

X: Applicable —: Not applicable

Items (CONSULT-III screen terms)	Malfunction is detected when...	DTC*1		Reference
		“TRANSMISSION” with CONSULT-III	MIL*2, “ENGINE” with CONSULT-III or GST	
CAN COMM CIRCUIT	When TCM is not transmitting or receiving CAN communication signal for 2 seconds or more	U1000	U1000	CVT-55
CONTROL UNIT(CAN)	When detecting error during the initial diagnosis of CAN controller of TCM	U1010	U1010	CVT-58
BRAKE SW/CIRC	When the brake switch does not switch to ON or OFF	P0703	—	CVT-59
PNP SW/CIRC	TCM does not receive the correct voltage signal (based on the gear position) from the switch.	P0705	P0705	CVT-61
ATF TEMP SEN/CIRC	During running, the CVT fluid temperature sensor signal voltage is excessively high or low	P0710	P0710	CVT-66
INPUT SPD SEN/CIRC	<ul style="list-style-type: none"> • Input speed sensor (primary speed sensor) signal is not input due to an open circuit • An unexpected signal is input when vehicle is being driven 	P0715	P0715	CVT-71
VEH SPD SEN/CIR AT	<ul style="list-style-type: none"> • Signal from vehicle speed sensor CVT [Output speed sensor (Secondary speed sensor)] not input due to open or short circuit • Unexpected signal input during running 	P0720	P0720	CVT-76
ENGINE SPEED SIG	<ul style="list-style-type: none"> • TCM does not receive the CAN communication signal from the ECM • Engine speed is too low while driving 	P0725	—	CVT-81
BELT DAMG	Unexpected gear ratio detected	P0730	—	CVT-83
TCC SOLENOID/CIRC	Normal voltage not applied to solenoid due to open or short circuit	P0740	P0740	CVT-84
A/T TCC S/V FNCTN	<ul style="list-style-type: none"> • CVT cannot perform lock-up even if electrical circuit is good • TCM detects as irregular by comparing difference value with slip rotation • There is big difference engine speed and primary speed when TCM lock-up signal is on 	P0744	P0744	CVT-89
L/PRESS SOL/CIRC	<ul style="list-style-type: none"> • Normal voltage not applied to solenoid due to open or short circuit • TCM detects as irregular by comparing target value with monitor value 	P0745	P0745	CVT-91
PRS CNT SOL/A FCTN	Unexpected gear ratio was detected in the LOW side due to excessively low line pressure	P0746	P0746	CVT-96
PRS CNT SOL/B FCTN	Secondary pressure is too high or too low compared with the commanded value while driving	P0776	P0776	CVT-98

TROUBLE DIAGNOSIS

< SERVICE INFORMATION >

Items (CONSULT-III screen terms)	Malfunction is detected when...	DTC*1		Reference	
		"TRANSMISSION" with CONSULT-III	MIL*2, "ENGINE" with CONSULT-III or GST		
PRS CNT SOL/B CIRC	<ul style="list-style-type: none"> Normal voltage not applied to solenoid due to cut line, short, or the like TCM detects as irregular by comparing target value with monitor value 	P0778	P0778	CVT-100	CVT
MANUAL MODE SWITCH	When an impossible pattern of switch signals is detected, a malfunction is detected.	P0826	—	CVT-105	D
TR PRS SENS/A CIRC	Signal voltage of the transmission fluid pressure sensor A (secondary pressure sensor) is too high or too low while driving	P0840	P0840	CVT-110	E
PRESS SEN/ FNCTN	Correlation between the values of the transmission fluid pressure sensor A (secondary pressure sensor) and the transmission fluid pressure sensor B (primary pressure sensor) is out of specification	P0841	—	CVT-114	F
SEC/PRESS DOWN	Secondary fluid pressure is too low compared with the commanded value while driving	P0868	—	CVT-116	G
TCM-POWER SUPPLY	<ul style="list-style-type: none"> When the power supply to the TCM is cut OFF, for example because the battery is removed, and the self-diagnosis memory function stops This is not a malfunction message (Whenever shutting OFF a power supply to the TCM, this message appears on the screen) 	P1701	—	CVT-118	H
TP SEN/CIRC A/T	TCM does not receive the proper accelerator pedal position signals (input by CAN communication) from ECM	P1705	—	CVT-122	I
ESTM VEH SPD SIG*3	<ul style="list-style-type: none"> CAN communication with the ABS actuator and the electric unit (control unit) is malfunctioning There is a great difference between the vehicle speed signal from the ABS actuator and the electric unit (control unit), and the vehicle speed sensor signal 	P1722	—	CVT-124	J
CVT SPD SEN/ FNCTN	A rotation sensor error is detected because the gear does not change in accordance with the position of the stepping motor CAUTION: One of the "P0720 VEH SPD SEN/CIR AT", the "P0715 INPUT SPD SEN/CIRC" or the "P0725 ENGINE SPEED SIG" is displayed with the DTC at the same time	P1723	—	CVT-126	K
ELEC TH CONTROL	The electronically controlled throttle for ECM is malfunctioning	P1726	—	CVT-128	L
LU-SLCT SOL/ CIRC	<ul style="list-style-type: none"> Normal voltage not applied to solenoid due to cut line, short, or the like TCM detects as irregular by comparing target value with monitor value 	P1740	P1740	CVT-129	M
L/PRESS CONTROL	TCM detects the unexpected line pressure	P1745	—	CVT-134	N
STEP MOTR CIRC	Each coil of the step motor is not energized properly due to an open or a short	P1777	P1777	CVT-135	O
STEP MOTR/FNC	There is a great difference between the number of steps for the stepping motor and for the actual gear ratio	P1778	P1778	CVT-139	P
NO DTC IS DETECTED: FURTHER TESTING MAY BE REQUIRED	No NG item has been detected	X	X	—	

*1: These numbers are prescribed by SAE J2012.

*2: Refer to [CVT-26, "Malfunction Indicator Lamp \(MIL\)"](#) .

TROUBLE DIAGNOSIS

< SERVICE INFORMATION >

*3: Models without ABS does not indicate.

DATA MONITOR MODE

Display Items List

X: Standard, —: Not applicable, ▼: Option

Monitored item (Unit)	Monitor item selection			Remarks
	ECU INPUT SIGNALS	MAIN SIGNALS	SELECTION FROM MENU	
VSP SENSOR (km/h)	X	—	▼	Output speed sensor (secondary speed sensor)
ESTM VSP SIG (km/h)	X	—	▼	Models without ABS dose not indicate
PRI SPEED SEN (rpm)	X	—	▼	
ENG SPEED SIG (rpm)	X	—	▼	
SEC HYDR SEN (V)	X	—	▼	
PRI HYDR SEN (V)	X	—	▼	Not mounted but displayed
ATF TEMP SEN (V)	X	—	▼	CVT fluid temperature sensor
VIGN SEN (V)	X	—	▼	
VEHICLE SPEED (km/h)	—	X	▼	Vehicle speed recognized by the TCM
PRI SPEED (rpm)	—	X	▼	Primary pulley speed
SEC SPEED (rpm)	—	—	▼	Secondary pulley speed
ENG SPEED (rpm)	—	X	▼	
SLIP REV (rpm)	—	X	▼	Difference between engine speed and primary pulley speed
GEAR RATIO	—	X	▼	
G SPEED (G)	—	—	▼	
ACC PEDAL OPEN (0.0/8)	X	X	▼	Degree of opening for accelerator recognized by the TCM For fail-safe operation, the specific value used for control is displayed
TRQ RTO	—	—	▼	
SEC PRESS (MPa)	—	X	▼	
PRI PRESS (MPa)	—	X	▼	Not mounted but displayed
ATFTEMP COUNT	—	X	▼	Means CVT fluid temperature. Actual oil temperature (°C) cannot be checked unless a numeric value is converted. Refer to CVT-12, "ATFTEMP COUNT Conversion Table" .
DSR REV (rpm)	—	—	▼	
DGEAR RATIO	—	—	▼	
DSTM STEP (step)	—	—	▼	
STM STEP (step)	—	X	▼	
LU PRS (MPa)	—	—	▼	
LINE PRS (MPa)	—	—	▼	
TGT SEC PRESS (MPa)	—	—	▼	

TROUBLE DIAGNOSIS

< SERVICE INFORMATION >

Monitored item (Unit)	Monitor item selection			Remarks	
	ECU INPUT SIGNALS	MAIN SIGNALS	SELECTION FROM MENU		
ISOLT1 (A)	—	X	▼	Torque converter clutch solenoid valve output current	A
ISOLT2 (A)	—	X	▼	Pressure control solenoid valve A (line pressure solenoid valve) output current	B
ISOLT3 (A)	—	X	▼	Pressure control solenoid valve B (secondary pressure solenoid valve) output current	CVT
SOLMON1 (A)	X	X	▼	Torque converter clutch solenoid valve monitor current	D
SOLMON2 (A)	X	X	▼	Pressure control solenoid valve A (line pressure solenoid valve) monitor current	E
SOLMON3 (A)	X	X	▼	Pressure control solenoid valve B (secondary pressure solenoid valve) monitor current	F
P POSITION SW (ON/OFF)	X	—	▼		G
R POSITION SW (ON/OFF)	X	—	▼		H
N POSITION SW (ON/OFF)	X	—	▼		I
D POSITION SW (ON/OFF)	X	—	▼		J
L POSITION SW (ON/OFF)	X	—	▼		K
BRAKE SW (ON/OFF)	X	X	▼	Stop lamp switch (Signal input with CAN communication)	L
FULL SW (ON/OFF)	X	X	▼		M
IDLE SW (ON/OFF)	X	X	▼	Signal input with CAN communication	N
SPORT MODE SW (ON/OFF)	X	X	▼		O
STRDWNSW (ON/OFF)*	X	—	▼	Responds only to vehicles with Manual mode	P
STRUPSW (ON/OFF)*	X	—	▼		
DOWNLVR (ON/OFF)	X	—	▼		
UPLVR (ON/OFF)	X	—	▼	Not mounted but displayed	
NON MMODE (ON/OFF)	X	—	▼		
MMODE (ON/OFF)	X	—	▼		
INDLRNG (ON/OFF)	—	—	▼	"L" position indicator output	
INDDRNG (ON/OFF)	—	—	▼	"D" position indicator output	
INDNRNG (ON/OFF)	—	—	▼	"N" position indicator output	
INDRRNG (ON/OFF)	—	—	▼	"R" position indicator output	
INDPRNG (ON/OFF)	—	—	▼	"P" position indicator output	
CVTLAMP (ON/OFF)	—	—	▼		
SPORT MODE IND (ON/OFF)	—	—	▼		
MMODE IND (ON/OFF)	—	—	▼	Not mounted but displayed	
SMCOIL D (ON/OFF)	—	—	▼	Step motor coil "D" energizing status	
SMCOIL C (ON/OFF)	—	—	▼	Step motor coil "C" energizing status	
SMCOIL B (ON/OFF)	—	—	▼	Step motor coil "B" energizing status	

TROUBLE DIAGNOSIS

< SERVICE INFORMATION >

Monitored item (Unit)	Monitor item selection			Remarks
	ECU INPUT SIGNALS	MAIN SIGNALS	SELECTION FROM MENU	
SMCOIL A (ON/OFF)	—	—	▼	Step motor coil "A" energizing status
LUSEL SOL OUT (ON/OFF)	—	—	▼	
LUSEL SOL MON (ON/OFF)	—	—	▼	
VDC ON (ON/OFF)	X	—	▼	Not mounted but displayed
TCS ON (ON/OFF)	X	—	▼	
ABS ON (ON/OFF)	X	—	▼	Models without ABS dose not indicate
ACC ON (ON/OFF)	X	—	▼	Not mounted but displayed
RANGE	—	X	▼	Indicates position is recognized by TCM. Indicates a specific value required for control when fail-safe function is activated
M GEAR POS	—	X	▼	Not mounted but displayed
Voltage (V)	—	—	▼	Displays the value measured by the voltage probe
Frequency (Hz)	—	—	▼	The value measured by the pulse probe is displayed
DUTY-HI (high) (%)	—	—	▼	
DUTY-LOW (low) (%)	—	—	▼	
PLS WIDTH-HI (ms)	—	—	▼	
PLS WIDTH-LOW (ms)	—	—	▼	

*: With QR25DE

Diagnosis Procedure without CONSULT-III

INFOID:000000004407080

OBD-II SELF-DIAGNOSTIC PROCEDURE (WITH GST)

Refer to [EC-131, "Generic Scan Tool \(GST\) Function"](#) .

DTC U1000 CAN COMMUNICATION LINE

< SERVICE INFORMATION >

DTC U1000 CAN COMMUNICATION LINE

Description

INFOID:000000004407081

CAN (Controller Area Network) is a serial communication line for real time application. It is an on-vehicle multiplex communication line with high data communication speed and excellent malfunction detection ability. Many electronic control units are equipped onto a vehicle, and each control unit shares information and links with other control units during operation (not independent). In CAN communication, control units are connected with 2 communication lines (CAN-H line, CAN-L line) allowing a high rate of information transmission with less wiring. Each control unit transmits/receives data but selectively reads required data only.

On Board Diagnosis Logic

INFOID:000000004407082

- This is an OBD-II self-diagnostic item.
- Diagnostic trouble code "U1000 CAN COMM CIRCUIT" with CONSULT-III is detected when TCM cannot communicate to other control units.

Possible Cause

INFOID:000000004407083

Harness or connectors
(CAN communication line is open or shorted.)

DTC Confirmation Procedure

INFOID:000000004407084

NOTE:

If "DTC Confirmation Procedure" has been previously performed, always turn ignition switch OFF and wait at least 10 seconds before performing the next test.

After the repair, touch "ERASE" on "SELF-DIAG RESULTS" and then perform the following procedure to confirm the malfunction is eliminated.

Ⓟ WITH CONSULT-III

1. Turn ignition switch ON.
2. Select "DATA MONITOR" mode for "TRANSMISSION" with CONSULT-III.
3. Start engine and wait for at least 6 seconds.
4. If DTC is detected, go to [CVT-57. "Diagnosis Procedure"](#).

Ⓢ WITH GST

Follow the procedure "WITH CONSULT-III".



DTC U1000 CAN COMMUNICATION LINE

< SERVICE INFORMATION >

Wiring Diagram - CVT - CAN

INFOID:000000004407085

CVT-CAN-01

-  : DETECTABLE LINE FOR DTC
-  : NON-DETECTABLE LINE FOR DTC
-  : DATA LINE

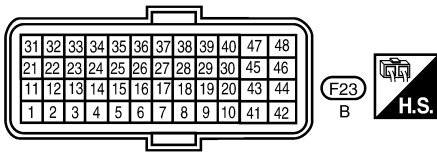
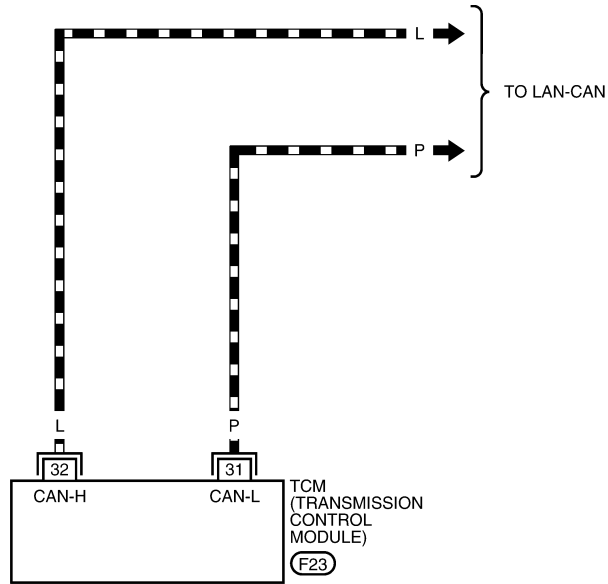

BCWA0736E

TCM TERMINALS AND REFERENCE VALUES

Refer to [CVT-45, "TCM Input/Output Signal Reference Value"](#).

DTC U1000 CAN COMMUNICATION LINE

< SERVICE INFORMATION >

Diagnosis Procedure

INFOID:000000004407086

1. CHECK CAN COMMUNICATION CIRCUIT

With CONSULT-III

1. Turn ignition switch ON and start engine.
2. Select "SELF-DIAG RESULTS" mode for "TRANSMISSION" with CONSULT-III.

Is any malfunction of the "U1000 CAN COMM CIRCUIT" indicated?

YES >> Print out CONSULT-III screen, go to LAN section. Refer to [LAN-15, "Trouble Diagnosis Flow Chart"](#).

NO >> **INSPECTION END**

A

B

CVT

D

E

F

G

H

I

J

K

L

M

N

O

P

DTC U1010 TRANSMISSION CONTROL MODULE (CAN)

< SERVICE INFORMATION >

DTC U1010 TRANSMISSION CONTROL MODULE (CAN)

Description

INFOID:000000004407087

CAN (Controller Area Network) is a serial communication line for real time application. It is an on-vehicle multiplex communication line with high data communication speed and excellent malfunction detection ability. Many electronic control units are equipped onto a vehicle, and each control unit shares information and links with other control units during operation (not independent). In CAN communication, control units are connected with 2 communication lines (CAN-H line, CAN-L line) allowing a high rate of information transmission with less wiring. Each control unit transmits/receives data but selectively reads required data only.

On Board Diagnosis Logic

INFOID:000000004407088

- This is an OBD-II self-diagnostic item.
- Diagnostic trouble code "U1010 CONTROL UNIT(CAN)" with CONSULT-III is detected when TCM cannot communicate to other control units.

Possible Cause

INFOID:000000004407089

Harness or connectors
(CAN communication line is open or shorted.)

DTC Confirmation Procedure

INFOID:000000004407090

NOTE:

If "DTC Confirmation Procedure" has been previously performed, always turn ignition switch OFF and wait at least 10 seconds before performing the next test.

After the repair, touch "ERASE" on "SELF-DIAG RESULTS" and then perform the following procedure to confirm the malfunction is eliminated.

④ WITH CONSULT-III

1. Turn ignition switch ON.
2. Select "DATA MONITOR" mode for "TRANSMISSION" with CONSULT-III.
3. Start engine and wait for at least 6 seconds.
4. If DTC is detected, go to [CVT-58. "Diagnosis Procedure"](#).

④ WITH GST

Follow the procedure "WITH CONSULT-III".

Diagnosis Procedure

INFOID:000000004407091

1. CHECK DTC

④ With CONSULT-III

1. Turn ignition switch ON.
2. Select "SELF-DIAG RESULTS" mode for "TRANSMISSION" with CONSULT-III.
3. Touch "ERASE".
4. Turn ignition switch OFF and wait for at least 10 seconds.
5. Perform "DTC confirmation procedure". Refer to [CVT-58. "DTC Confirmation Procedure"](#).

Is any malfunction of the "U1010 CONTROL UNIT(CAN)" indicated?

- YES >> Replace the TCM. Refer to [CVT-162. "Removal and Installation"](#).
NO >> **INSPECTION END**

DTC P0703 STOP LAMP SWITCH CIRCUIT

< SERVICE INFORMATION >

DTC P0703 STOP LAMP SWITCH CIRCUIT

Description

INFOID:000000004407092

ON, OFF status of the stop lamp switch is sent via the CAN communication from the combination meter to TCM using the signal.

CONSULT-III Reference Value

INFOID:000000004407093

Item name	Condition	Display value
BRAKE SW	Depressed brake pedal	ON
	Released brake pedal	OFF

On Board Diagnosis Logic

INFOID:000000004407094

- This is not an OBD-II self-diagnostic item.
- Diagnostic trouble code "P0703 BRAKE SW/CIRC" with CONSULT-III is detected when the stop lamp switch does not switch to ON and OFF.
- The stop lamp switch does not switch to ON and OFF.

Possible Cause

INFOID:000000004407095

- Harness or connectors
(Stop lamp switch, and combination meter circuit are open or shorted.)
(CAN communication line is open or shorted.)
- Stop lamp switch

DTC Confirmation Procedure

INFOID:000000004407096

CAUTION:

Always drive vehicle at a safe speed.

NOTE:

If "DTC Confirmation Procedure" has been previously performed, always turn ignition switch OFF and wait at least 10 seconds before performing the next test.

After the repair, touch "ERASE" on "SELF-DIAG RESULTS" and then perform the following procedure to confirm the malfunction is eliminated.

④ WITH CONSULT-III

1. Turn ignition switch ON. (Do not start engine.)
2. Select "DATA MONITOR" mode for "TRANSMISSION" with CONSULT-III.
3. Start engine.
4. Start vehicle for at least 3 consecutive seconds.
5. If DTC is detected, go to [CVT-59, "Diagnosis Procedure"](#).

Diagnosis Procedure

INFOID:000000004407097

1. CHECK CAN COMMUNICATION LINE

Perform the self-diagnosis check. Refer to [CVT-47, "CONSULT-III Function \(TRANSMISSION\)"](#).

Is any malfunction of the "U1000 CAN COMM CIRCUIT" indicated?

YES >> Check CAN communication line. Refer to [CVT-55](#).

NO >> GO TO 2.

2. CHECK STOP LAMP SWITCH CIRCUIT

④ With CONSULT-III

1. Turn ignition switch ON.
2. Select "ECU INPUT SIGNALS" in "DATA MONITOR" mode for "TRANSMISSION" with CONSULT-III.
3. Read out ON/OFF switching action of the "BRAKE SW".

DTC P0703 STOP LAMP SWITCH CIRCUIT

< SERVICE INFORMATION >

Item name	Condition	Display value
BRAKE SW	Depressed brake pedal	ON
	Released brake pedal	OFF

OK or NG

OK >> **INSPECTION END**

NG >> GO TO 3.

3.CHECK STOP LAMP SWITCH

Check continuity between stop lamp switch harness connector E60 terminals 1 and 2. Refer to [CVT-147, "Wiring Diagram - CVT - NONDTC"](#).

Condition	Continuity
When brake pedal is depressed	Yes
When brake pedal is released	No

Check stop lamp switch after adjusting brake pedal — refer to [BR-5](#).

OK or NG

OK >> Check the following. If NG, repair or replace damaged parts.

- Harness for short or open between battery and stop lamp switch.
- Harness for short or open between stop lamp switch and combination meter.

NG >> Repair or replace the stop lamp switch.

DTC P0705 PARK/NEUTRAL POSITION SWITCH

< SERVICE INFORMATION >

DTC P0705 PARK/NEUTRAL POSITION SWITCH

Description

INFOID:000000004407098

- The PNP switch assembly includes a transaxle range switch.
- The transaxle range switch detects the selector lever position and sends a signal to the TCM.

CONSULT-III Reference Value

INFOID:000000004407099

Item name	Condition	Display value
P POSITION SW	Selector lever in "P" position	ON
	When setting selector lever to other positions.	OFF
R POSITION SW	Selector lever in "R" position	ON
	When setting selector lever to other positions.	OFF
N POSITION SW	Selector lever in "N" position	ON
	When setting selector lever to other positions.	OFF
D POSITION SW	Selector lever in "D" position	ON
	When setting selector lever to other positions.	OFF
L POSITION SW	Selector lever in "L" position	ON
	When setting selector lever to other positions.	OFF
RANGE	Selector lever in "N" or "P" position	N·P
	Selector lever in "R" position	R
	Selector lever in "D" position	D
	Selector lever in "L" position	L

On Board Diagnosis Logic

INFOID:000000004407100

- This is an OBD-II self-diagnostic item.
- Diagnostic trouble code "P0705 PNP SW/CIRC" with CONSULT-III is detected when TCM does not receive the correct voltage signal from the switch based on the gear position.

Possible Cause

INFOID:000000004407101

- Harness or connectors
(The PNP switch circuit is open or shorted.)
- PNP switch

DTC Confirmation Procedure

INFOID:000000004407102

CAUTION:

Always drive vehicle at a safe speed.

NOTE:

If "DTC Confirmation Procedure" has been previously performed, always turn ignition switch OFF and wait at least 10 seconds before performing the next test.

After the repair, touch "ERASE" on "SELF-DIAG RESULTS" and then perform the following procedure to confirm the malfunction is eliminated.

WITH CONSULT-III

1. Turn ignition switch ON.
2. Select "DATA MONITOR" mode for "TRANSMISSION" with CONSULT-III.
3. Start engine.
4. Drive vehicle and maintain the following conditions for at least 2 consecutive seconds.
VEHICLE SPEED: More than 10 km/h (6 MPH)
ENG SPEED: More than 450 rpm
ACC PEDAL OPEN: More than 1.0/8
5. If DTC is detected, go to [CVT-63. "Diagnosis Procedure"](#).

DTC P0705 PARK/NEUTRAL POSITION SWITCH

< SERVICE INFORMATION >

WITH GST

Follow the procedure "WITH CONSULT-III".

Wiring Diagram - CVT - PNP/SW

INFOID:000000004407103

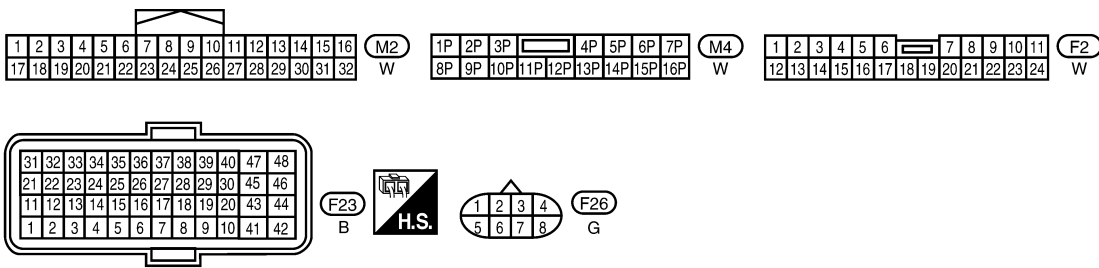
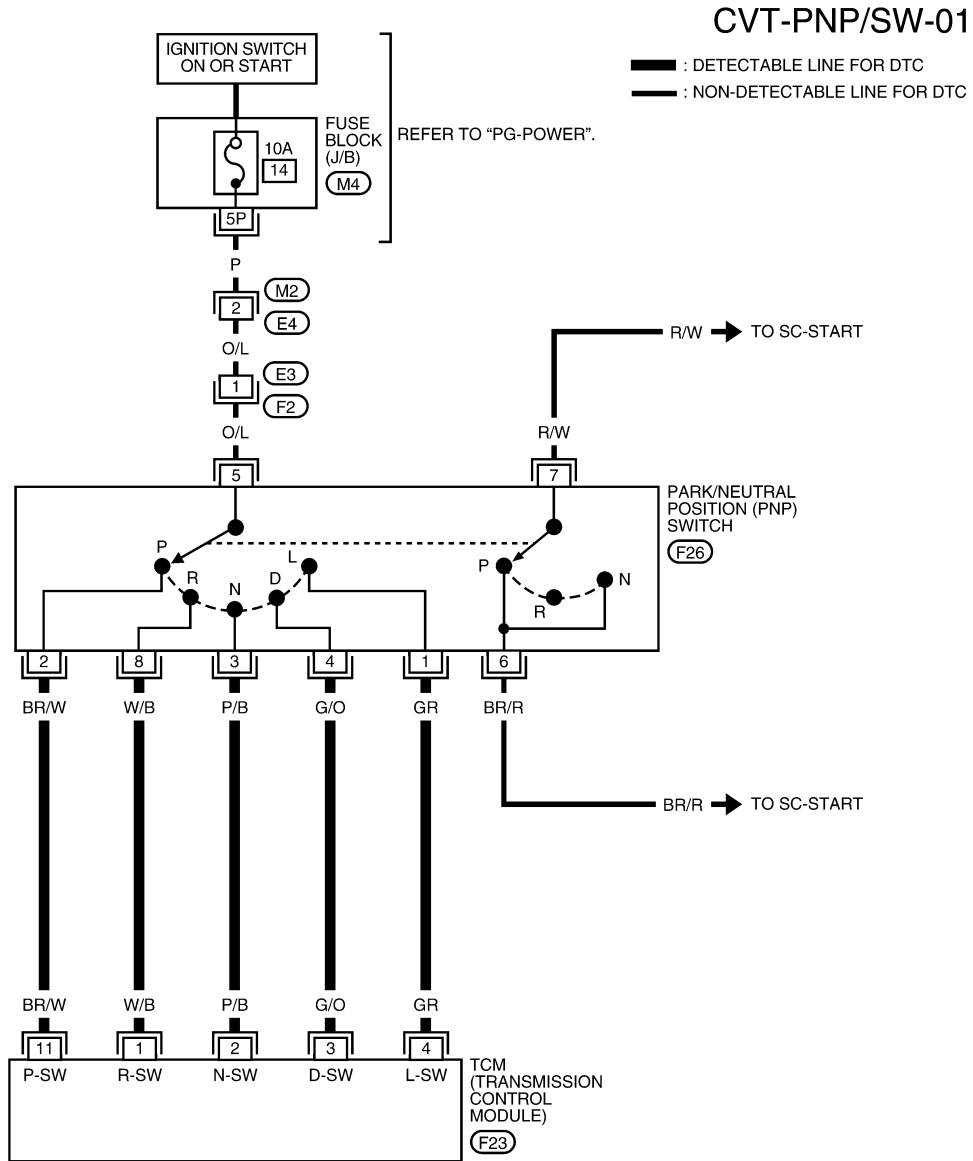

AADWA0049GI

TCM TERMINALS AND REFERENCE VALUES

CVT-62

DTC P0705 PARK/NEUTRAL POSITION SWITCH

< SERVICE INFORMATION >

Refer to [CVT-45, "TCM Input/Output Signal Reference Value"](#).

Diagnosis Procedure

INFOID:000000004407104

1. CHECK PNP SW SIGNALS

With CONSULT-III

1. Turn ignition switch ON.
2. Select "ECU INPUT SIGNALS" in "DATA MONITOR" mode for "TRANSMISSION" with CONSULT-III.
3. Read out "P", "R", "N", "D" and "L" position switches moving selector lever to each position.

Item name	Condition	Display value
P POSITION SW	When setting selector lever to "P" position.	ON
	When setting selector lever to other positions.	OFF
R POSITION SW	When setting selector lever to "R" position.	ON
	When setting selector lever to other positions.	OFF
N POSITION SW	When setting selector lever to "N" positions.	ON
	When setting selector lever to other positions.	OFF
D POSITION SW	When setting selector lever to "D" position.	ON
	When setting selector lever to other positions.	OFF
L POSITION SW	When setting selector lever to "L" position.	ON
	When setting selector lever to other positions.	OFF

Without CONSULT-III

1. Turn ignition switch ON.
2. Check voltage between TCM connector terminals and ground while moving selector lever through each position.

Selector lever position	Terminal				
	11	1	2	3	4
P	B	0	0	0	0
R	0	B	0	0	0
N	0	0	B	0	0
D	0	0	0	B	0
L	0	0	0	0	B

B: Battery voltage

0: 0V

OK or NG

OK >> GO TO 5.

NG >> GO TO 2.

2. CHECK PNP SWITCH

1. Turn ignition switch OFF.
2. Disconnect PNP switch harness connector.

DTC P0705 PARK/NEUTRAL POSITION SWITCH

< SERVICE INFORMATION >

3. Check continuity between PNP switch harness connector terminals.

Selector lever position	Connector	Terminal	Continuity
P	F26	2 - 5, 6 - 7	Yes *Continuity should not exist in positions other than the specified positions.
R		5 - 8	
N		3 - 5, 6 - 7	
D		4 - 5	
L		1 - 5	

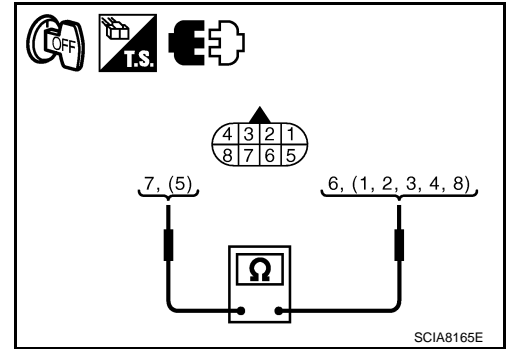

OK or NG

- OK >> GO TO 4.
NG >> GO TO 3.

3. CHECK CONTROL CABLE ADJUSTMENT

Check PNP switch again with control cable disconnected from manual shaft of A/T assembly. Refer to test group 2.

OK or NG

- OK >> Adjust control cable. Refer to [CVT-170. "Adjustment of CVT Position"](#).
NG >> Check PNP switch (Refer to test group 1) again after adjusting PNP switch (Refer to [CVT-182](#)).
• If OK, **INSPECTION END**
• If NG, repair or replace PNP switch. Refer to [CVT-182. "Park/Neutral Position \(PNP\) Switch"](#).

4. DETECT MALFUNCTIONING ITEM

Check the following items.

- Harness for short or open between ignition switch and PNP switch.
- Harness for short or open between PNP switch and TCM.
- 10A fuse [No.14, located in the fuse block (J/B)].
- Ignition switch. Refer to [PG-3](#).

OK or NG

- OK >> GO TO 5.
NG >> Repair or replace damaged parts.

5. CHECK DTC

Perform [CVT-61. "DTC Confirmation Procedure"](#).

OK or NG

- OK >> **INSPECTION END**
NG >> GO TO 6.

6. CHECK TCM

1. Check TCM input/output signals. Refer to [CVT-45. "TCM Input/Output Signal Reference Value"](#).
2. If NG, re-check TCM pin terminals for damage or loose connection with harness connector.

OK or NG

- OK >> **INSPECTION END**
NG >> 1. Repair or replace damaged parts.
2. Replace the transaxle assembly. Refer to [CVT-190. "Removal and Installation \(MR20DE\)"](#).

Component Inspection

INFOID:000000004407105

PNP SWITCH

DTC P0705 PARK/NEUTRAL POSITION SWITCH

< SERVICE INFORMATION >

1. Check continuity between PNP switch harness connector terminals.

Selector lever position	Connector	Terminal	Continuity
P	F26	2 - 5, 6 - 7	Yes *Continuity should not exist in positions other than the specified positions.
R		5 - 8	
N		3 - 5, 6 - 7	
D		4 - 5	
L		1 - 5	

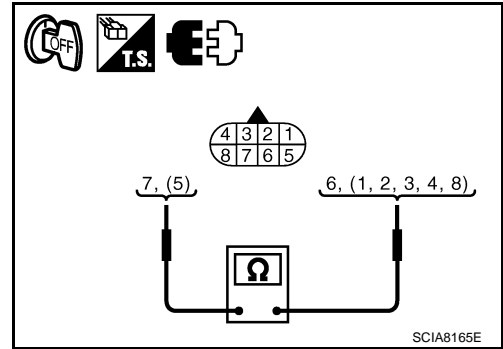

2. If NG, check again with control cable (2) disconnected from manual shaft of CVT assembly. Refer to step 1.
(1): Manual shaft
(A): Lock nut
3. If OK on step 2, adjust control cable (2). Refer to [CVT-170, "Adjustment of CVT Position"](#).
4. If NG on step 2, remove PNP switch from CVT and check continuity of PNP switch terminals. Refer to step 1.
5. If OK on step 4, adjust PNP switch. Refer to [CVT-171, "Adjustment of PNP switch"](#).
6. If NG on step 4, replace PNP switch. Refer to [CVT-182, "Park/Neutral Position \(PNP\) Switch"](#).

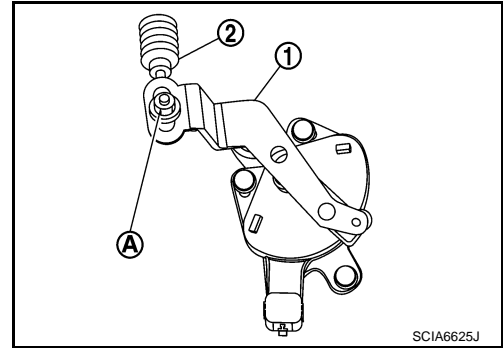

A
B
CVT
D
E
F
G
H
I
J
K
L
M
N
O
P

DTC P0710 CVT FLUID TEMPERATURE SENSOR CIRCUIT

< SERVICE INFORMATION >

DTC P0710 CVT FLUID TEMPERATURE SENSOR CIRCUIT

Description

INFOID:000000004407106

- The CVT fluid temperature sensor is included in the control valve assembly.
- The CVT fluid temperature sensor detects the CVT fluid temperature and sends a signal to the TCM.

CONSULT-III Reference Value

INFOID:000000004407107

Remarks: Specification data are reference values.

Item name	Condition	Display value (Approx.)
ATF TEMP SEN	When CVT fluid temperature is 20°C (68°F)	2.0 V
	When CVT fluid temperature is 80°C (176°F)	1.0 V

On Board Diagnosis Logic

INFOID:000000004407108

- This is an OBD-II self-diagnostic item.
- Diagnostic trouble code “P0710 ATF TEMP SEN/CIRC” with CONSULT-III is detected when TCM receives an excessively low or high voltage from the sensor.

Possible Cause

INFOID:000000004407109

- Harness or connectors
(Sensor circuit is open or shorted.)
- CVT fluid temperature sensor

DTC Confirmation Procedure

INFOID:000000004407110

CAUTION:

Always drive vehicle at a safe speed.

NOTE:

If “DTC Confirmation Procedure” has been previously performed, always turn ignition switch OFF and wait at least 10 seconds before performing the next test.

After the repair, touch “ERASE” on “SELF-DIAG RESULTS” and then perform the following procedure to confirm the malfunction is eliminated.

Ⓔ WITH CONSULT-III

1. Turn ignition switch ON.
2. Select “DATA MONITOR” mode for “TRANSMISSION” with CONSULT-III.
3. Start engine and maintain the following conditions for at least 10 minutes (Total).
VEHICLE SPEED: 10 km/h (6 MPH) or more
ENG SPEED: 450 rpm more than
ACC PEDAL OPEN: More than 1.0/8
RANGE: “D” position
4. If DTC is detected, go to [CVT-68, "Diagnosis Procedure"](#).

Ⓕ WITH GST

Follow the procedure “WITH CONSULT-III”.

DTC P0710 CVT FLUID TEMPERATURE SENSOR CIRCUIT

< SERVICE INFORMATION >

Wiring Diagram - CVT - FTS

INFOID:000000004407111

CVT-FTS-01

: DETECTABLE LINE FOR DTC
 : NON-DETECTABLE LINE FOR DTC

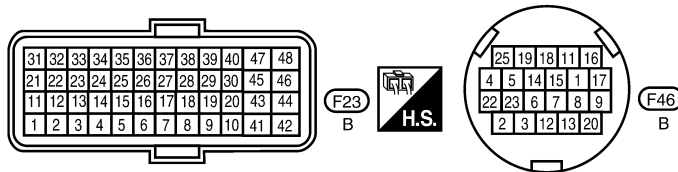
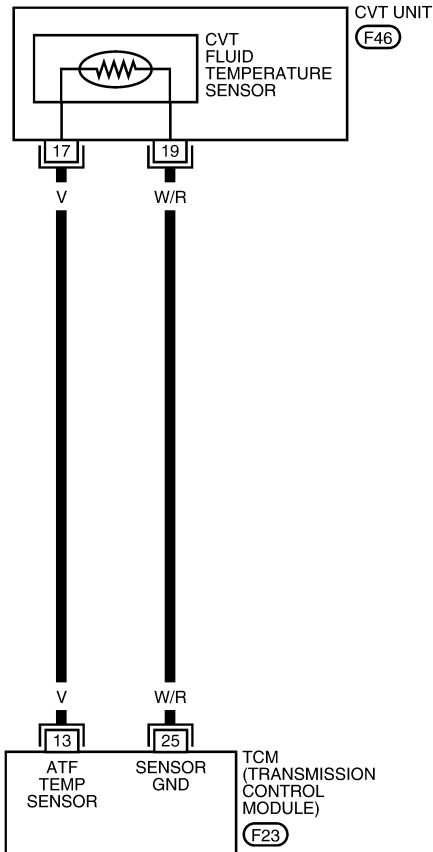

TCM TERMINALS AND REFERENCE VALUES

Refer to [CVT-45, "TCM Input/Output Signal Reference Value"](#).

DTC P0710 CVT FLUID TEMPERATURE SENSOR CIRCUIT

< SERVICE INFORMATION >

Diagnosis Procedure

INFOID:000000004407112

1. CHECK CVT FLUID TEMPERATURE SENSOR SIGNAL

With CONSULT-III

1. Start engine.
2. Select "ECU INPUT SIGNALS" in "DATA MONITOR" mode for "TRANSMISSION" with CONSULT-III.
3. Read out the value of "ATF TEMP SEN".

Item name	Condition	Display value (Approx.)
ATF TEMP SEN	When CVT fluid temperature is 20°C (68°F)	2.0 V
	When CVT fluid temperature is 80°C (176°F)	1.0 V

Without CONSULT-III

1. Start engine.
2. Check voltage between TCM connector terminals.

Name	Connector	Terminal	Temperature °C (°F)	Voltage (Approx.)
CVT fluid temperature sensor	F23	13 - 25	20 (68)	2.0 V
			80 (176)	1.0 V

3. Turn ignition switch OFF.
4. Disconnect TCM connector.
5. Check if there is continuity between connector terminal and ground.

OK or NG

- OK >> GO TO 5.
NG >> GO TO 2.

2. CHECK CVT FLUID TEMPERATURE SENSOR CIRCUIT

1. Turn ignition switch OFF.
2. Disconnect the TCM connector.
3. Check resistance between TCM connector terminals.

Name	Connector	Terminal	Temperature °C (°F)	Resistance (Approx.)
CVT fluid temperature sensor	F23	13 - 25	20 (68)	6.5 kΩ
			80 (176)	0.9 kΩ

OK or NG

- OK >> GO TO 5.
NG >> GO TO 3.

3. CHECK CVT FLUID TEMPERATURE SENSOR

1. Turn ignition switch OFF.
2. Disconnect CVT unit harness connector.

DTC P0710 CVT FLUID TEMPERATURE SENSOR CIRCUIT

< SERVICE INFORMATION >

3. Check resistance between CVT unit harness connector terminals.

Name	Connector	Terminal	Temperature °C (°F)	Resistance (Approx.)
CVT fluid temperature sensor	F46	17 - 19	20 (68)	6.5 kΩ
			80 (176)	0.9 kΩ

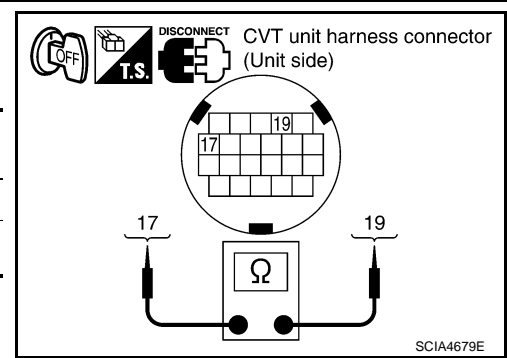

4. Reinstall any part removed.

OK or NG

OK >> GO TO 4.

NG >> Replace the transaxle assembly. Refer to [CVT-190. "Removal and Installation \(MR20DE\)".](#)

4. CHECK HARNESS BETWEEN TCM AND CVT FLUID TEMPERATURE SENSOR

1. Turn ignition switch OFF.
2. Disconnect the TCM connector (A) and CVT unit harness connector (B).
3. Check continuity between TCM connector (A) terminals and CVT unit harness connector (B) terminals.

Item	Connector	Terminal	Continuity
TCM	F23	13	Yes
CVT unit harness connector	F46	17	
TCM	F23	25	Yes
CVT unit harness connector	F46	19	

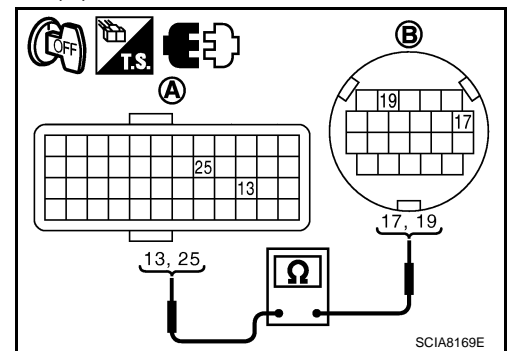

4. If OK, check harness for short to ground and short to power.
5. Reinstall any part removed.

OK or NG

OK >> GO TO 5.

NG >> Repair or replace damaged parts.

5. CHECK DTC

Perform [CVT-66. "DTC Confirmation Procedure".](#)

OK or NG

OK >> **INSPECTION END**

NG >> GO TO 6.

6. CHECK TCM

1. Check TCM input/output signals. Refer to [CVT-45. "TCM Input/Output Signal Reference Value".](#)
2. If NG, re-check TCM pin terminals for damage or loose connection with harness connector.

OK or NG

OK >> **INSPECTION END**

NG >> Repair or replace damaged parts.

Component Inspection

INFOID:000000004407113

CVT FLUID TEMPERATURE SENSOR

1. Turn ignition switch OFF.
2. Disconnect CVT unit harness connector.

DTC P0710 CVT FLUID TEMPERATURE SENSOR CIRCUIT

< SERVICE INFORMATION >

3. Check resistance between CVT unit harness connector terminals.

Name	Connector	Terminal	Temperature °C (°F)	Resistance (Approx.)
CVT fluid temperature sensor	F46	17 - 19	20 (68)	6.5 kΩ
			80 (176)	0.9 kΩ

4. If NG, replace the transaxle assembly. Refer to [CVT-190](#), "[Removal and Installation \(MR20DE\)](#)".

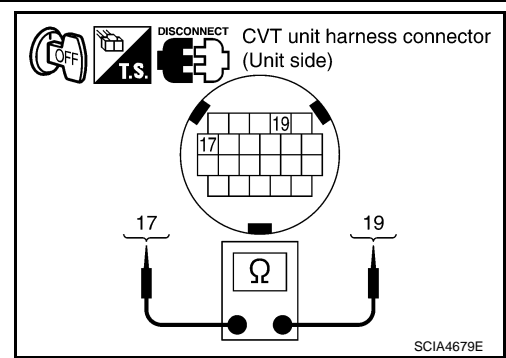

DTC P0715 INPUT SPEED SENSOR CIRCUIT (PRI SPEED SENSOR)

< SERVICE INFORMATION >

DTC P0715 INPUT SPEED SENSOR CIRCUIT (PRI SPEED SENSOR)

Description

INFOID:000000004407114

The input speed sensor (primary speed sensor) detects the primary pulley revolution speed and sends a signal to the TCM.

CONSULT-III Reference Value

INFOID:000000004407115

Remarks: Specification data are reference values.

Item name	Condition	Display value
ENG SPEED SIG	Engine running	Closely matches the tachometer reading.
PRI SPEED SEN	During driving (lock-up ON)	Approximately matches the engine speed.

On Board Diagnosis Logic

INFOID:000000004407116

- This is an OBD-II self-diagnostic item.
- Diagnostic trouble code "P0715 INPUT SPD SEN/CIRC" with CONSULT-III is detected when TCM does not receive the proper signal from the sensor.

Possible Cause

INFOID:000000004407117

- Harness or connectors
(Sensor circuit is open or shorted.)
- Input speed sensor (Primary speed sensor)

DTC Confirmation Procedure

INFOID:000000004407118

CAUTION:

Always drive vehicle at a safe speed.

NOTE:

If "DTC Confirmation Procedure" has been previously performed, always turn ignition switch OFF and wait at least 10 seconds before performing the next test.

After the repair, touch "ERASE" on "SELF-DIAG RESULTS" and then perform the following procedure to confirm the malfunction is eliminated.

Ⓟ WITH CONSULT-III

1. Turn ignition switch ON and select "DATA MONITOR" mode for "TRANSMISSION" with CONSULT-III.
2. Start engine and maintain the following conditions for at least 5 consecutive seconds.
VEHICLE SPEED: 10 km/h (6 MPH) or more
ACC PEDAL OPEN: More than 1.0/8
RANGE: "D" position
ENG SPEED: 450 rpm or more
Driving location: Driving the vehicle uphill (increased engine load) will help maintain the driving conditions required for this test.
3. If DTC is detected, go to [CVT-73, "Diagnosis Procedure"](#).

Ⓢ WITH GST

Follow the procedure "WITH CONSULT-III".

DTC P0715 INPUT SPEED SENSOR CIRCUIT (PRI SPEED SENSOR)

< SERVICE INFORMATION >

Wiring Diagram - CVT - PRSCVT

INFOID:000000004407119

CVT-PRSCVT-01

: DETECTABLE LINE FOR DTC
 : NON-DETECTABLE LINE FOR DTC

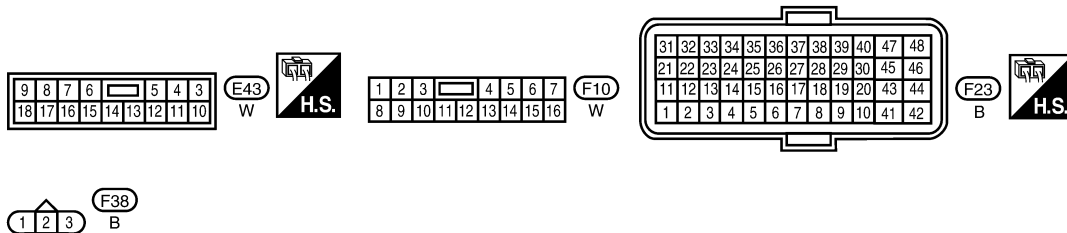
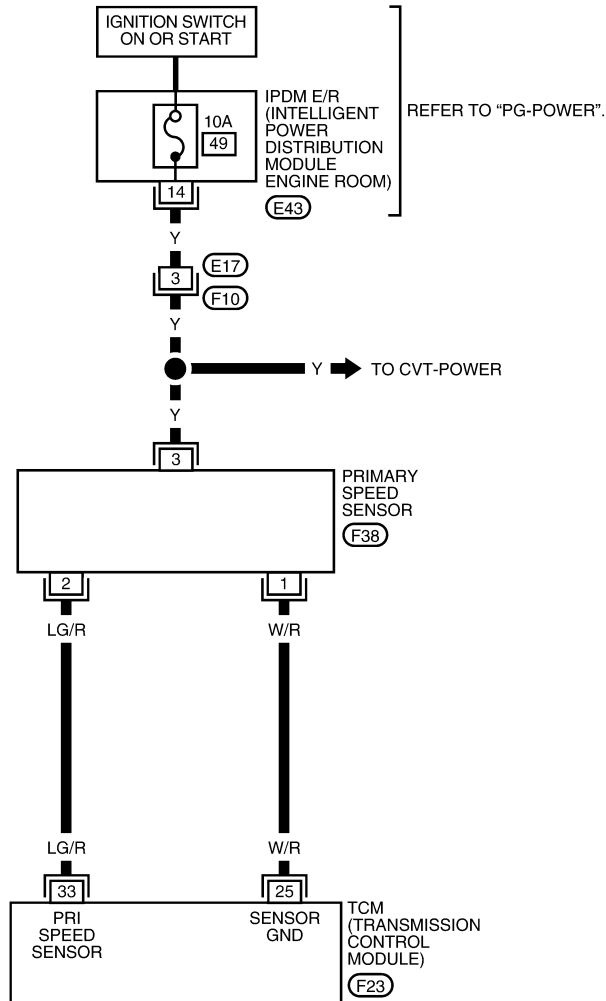

BCWA0739E

TCM TERMINALS AND REFERENCE VALUES

Refer to [CVT-45, "TCM Input/Output Signal Reference Value"](#).

DTC P0715 INPUT SPEED SENSOR CIRCUIT (PRI SPEED SENSOR)

< SERVICE INFORMATION >

INFOID:000000004407120

Diagnosis Procedure

1. CHECK INPUT SIGNAL

With CONSULT-III

1. Start engine.
2. Select "ECU INPUT SIGNALS" in "DATA MONITOR" mode for "TRANSMISSION" with CONSULT-III.
3. Start vehicle and read out the value of "VSP SENSOR".

Item name	Condition	Display value
PRI SPEED SEN	During driving (lock-up ON)	Approximately matches the speedometer reading.

OK or NG

- OK >> GO TO 8.
NG >> GO TO 2.

2. CHECK PRIMARY SPEED SENSOR

With CONSULT-III

1. Start engine.
2. Check power supply to input speed sensor (primary speed sensor) by voltage between TCM connector terminals 25, 46 and 48. Refer to [CVT-35. "Circuit Diagram"](#).

Item	Connector	Terminal	Data (Approx.)
TCM	F23	25 - 46	Battery voltage
		25 - 48	

3. If OK, check the pulse when vehicle cruises.

Name	Condition
Input speed sensor (Primary speed sensor)	When running at 20 km/h (12 MPH) in "L" position, use the CONSULT-III pulse frequency measuring function. CAUTION: Connect the data link connector to the vehicle-side diagnosis connector.

Item	Connector	Terminal	Name	Data (Approx.)
TCM	F23	33	Input speed sensor (Primary speed sensor)	890 Hz

OK or NG

- OK >> GO TO 8.
NG >> GO TO 3.

3. CHECK POWER AND SENSOR GROUND

1. Turn ignition switch OFF.
2. Disconnect the input speed sensor (primary speed sensor) harness connector.
3. Turn ignition switch ON.

DTC P0715 INPUT SPEED SENSOR CIRCUIT (PRI SPEED SENSOR)

< SERVICE INFORMATION >

4. Check voltage between input speed sensor (primary speed sensor) harness connector terminals.

Item	Connector	Terminal	Data (Approx.)
Input speed sensor (Primary speed sensor)	F38	3 - 1	Battery voltage

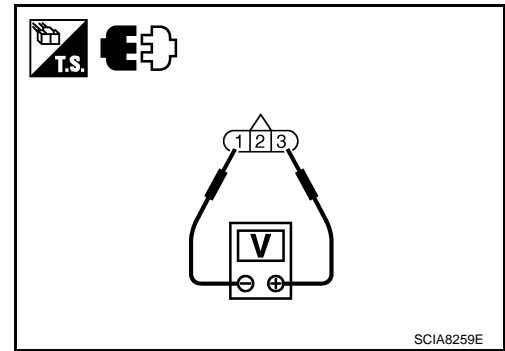

5. Check voltage between input speed sensor (primary speed sensor) harness connector terminal and ground.

Item	Connector	Terminal	Data (Approx.)
Input speed sensor (Primary speed sensor)	F38	3 - ground	Battery voltage

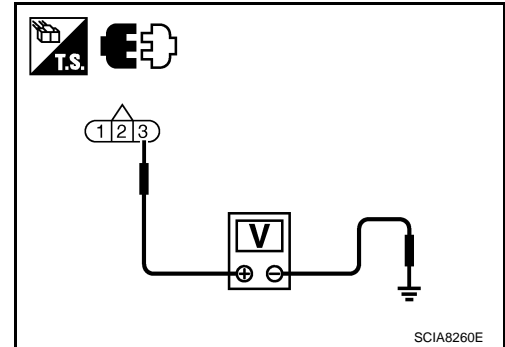

6. If OK, check harness for short to ground and short to power.
7. Reinstall any part removed.

OK or NG

OK >> GO TO 4.

NG - 1 >> Battery voltage is not supplied between terminals 1 and 3, terminals 1 and ground: GO TO 6.

NG - 2 >> Battery voltage is not supplied between terminals 1 and 3 only: GO TO 7.

4. CHECK HARNESS BETWEEN TCM AND INPUT SPEED SENSOR (PRIMARY SPEED SENSOR)

- Turn ignition switch OFF.
- Disconnect TCM connector (A) and input speed sensor (primary speed sensor) harness connector (B).
- Check continuity between TCM connector (A) terminal and input speed sensor (primary speed sensor) harness connector (B) terminal.

Item	Connector	Terminal	Continuity
TCM	F23	33	Yes
Input speed sensor (Primary speed sensor)	F38	2	

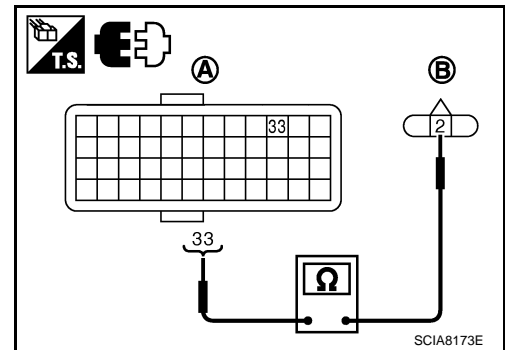

- If OK, check harness for short to ground and short to power.
- Reinstall any part removed.

OK or NG

OK >> GO TO 5.

NG >> Repair open circuit or short to ground or short to power in harness or connectors.

5. CHECK THE TCM SHORT

Replace same type TCM, perform self-diagnosis check. Erase self-diagnostic results and then drive the vehicle [more than 40 km/h (25 MPH)], perform self-diagnosis check. Refer to [CVT-76, "DTC Confirmation Procedure"](#).

Is "P0715 PRI SPEED SEN" detected again?

YES >> Replace the Primary speed sensor. Refer to [CVT-182, "Primary Speed Sensor"](#).

NO >> Replace TCM. Refer to [CVT-162, "Removal and Installation"](#).

6. CHECK HARNESS BETWEEN TCM AND INPUT SPEED SENSOR (PRIMARY SPEED SENSOR) (POWER)

- Turn ignition switch OFF.
- Disconnect TCM connector, IPDM E/R connector, input speed sensor (primary speed sensor) and output speed sensor (secondary speed sensor) harness connector.

DTC P0715 INPUT SPEED SENSOR CIRCUIT (PRI SPEED SENSOR)

< SERVICE INFORMATION >

- Check continuity between TCM connector terminals, IPDM E/R harness connector terminal, input speed sensor (primary speed sensor) harness connector terminal and output speed sensor (secondary speed sensor) harness connector terminal. Refer to [CVT-35. "Circuit Diagram"](#).

Item	Connector	Terminal	Continuity
TCM*	F23	46, 48	Yes
IPDM E/R*	E43	14	
Input speed sensor (Primary speed sensor)*	F38	3	
Output speed sensor (Secondary speed sensor)*	F30	3	

*: Vehicle side

- If OK, check harness for short to ground and short to power.
- Reinstall any part removed.

OK or NG

- OK >> 10 A fuse (No. 49, located in the IPDM E/R) or ignition switch are malfunctioning.
 NG >> Repair open circuit or short to ground or short to power in harness or connectors.

7. CHECK HARNESS BETWEEN TCM AND INPUT SPEED SENSOR (PRIMARY SPEED SENSOR) (SENSOR GROUND)

- Turn ignition switch OFF.
- Disconnect TCM connector (A) and input speed sensor (primary speed sensor) harness connector (B).
- Check continuity between TCM (A) connector terminal and input speed sensor (primary speed sensor) harness connector (B) terminal.

Item	Connector	Terminal	Continuity
TCM	F23	25	Yes
input speed sensor (Primary speed sensor)	F38	1	

- If OK, check harness for short to ground and short to power.
- Reinstall any part removed.

OK or NG

- OK >> GO TO 8.
 NG >> Repair open circuit or short to ground or short to power in harness or connectors.

8. CHECK DTC

Perform [CVT-76. "DTC Confirmation Procedure"](#).

OK or NG

- OK >> **INSPECTION END**
 NG >> GO TO 9.

9. CHECK TCM

- Check TCM input/output signals. Refer to [CVT-45. "TCM Input/Output Signal Reference Value"](#).
- If NG, re-check TCM pin terminals for damage or loose connection with harness connector.

OK or NG

- OK >> **INSPECTION END**
 NG >> Repair or replace damaged parts.

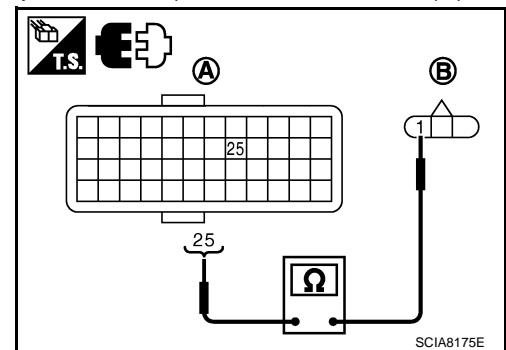

DTC P0720 VEHICLE SPEED SENSOR CVT (SECONDARY SPEED SENSOR)

< SERVICE INFORMATION >

DTC P0720 VEHICLE SPEED SENSOR CVT (SECONDARY SPEED SENSOR)

Description

INFOID:000000004407121

The vehicle speed sensor CVT [output speed sensor (secondary speed sensor)] detects the revolution of the CVT output shaft and emits a pulse signal. The pulse signal is sent to the TCM, which converts it into vehicle speed.

CONSULT-III Reference Value

INFOID:000000004407122

Remarks: Specification data are reference values.

Item name	Condition	Display value
VSP SENSOR	During driving	Approximately matches the speedometer reading.

On Board Diagnosis Logic

INFOID:000000004407123

- This is an OBD-II self-diagnostic item.
- Diagnostic trouble code "P0720 VEH SPD SEN/CIR AT" with CONSULT-III is detected TCM does not receive the proper signal from the sensor.

Possible Cause

INFOID:000000004407124

- Harness or connectors
(Sensor circuit is open or shorted.)
- Output speed sensor (Secondary speed sensor)

DTC Confirmation Procedure

INFOID:000000004407125

CAUTION:

Always drive vehicle at a safe speed.

NOTE:

If "DTC Confirmation Procedure" has been previously performed, always turn ignition switch OFF and wait at least 10 seconds before performing the next test.

After the repair, touch "ERASE" on "SELF-DIAG RESULTS" and then perform the following procedure to confirm the malfunction is eliminated.

Ⓜ WITH CONSULT-III

1. Turn ignition switch ON and select "DATA MONITOR" mode for "TRANSMISSION" with CONSULT-III.
2. Start engine and maintain the following conditions for at least 12 consecutive seconds.
ACC PEDAL OPEN: More than 1.0/8
RANGE: "D" position
Driving location: Driving the vehicle uphill (increased engine load) will help maintain the driving conditions required for this test.
3. If DTC is detected, go to [CVT-78, "Diagnosis Procedure"](#).

Ⓜ WITH GST

Follow the procedure "WITH CONSULT-III".

DTC P0720 VEHICLE SPEED SENSOR CVT (SECONDARY SPEED SENSOR)

< SERVICE INFORMATION >

Wiring Diagram - CVT - SESCOVT

INFOID:000000004407126

A
B
C
D
E
F
G
H
I
J
K
L
M
N
O
P

CVT

CVT-SESCVT-01

— : DETECTABLE LINE FOR DTC
- - - : NON-DETECTABLE LINE FOR DTC

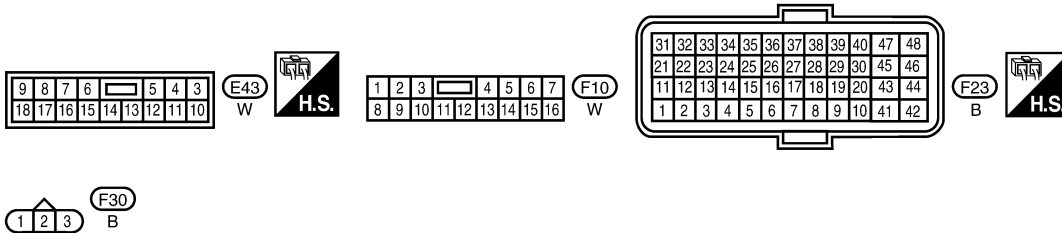
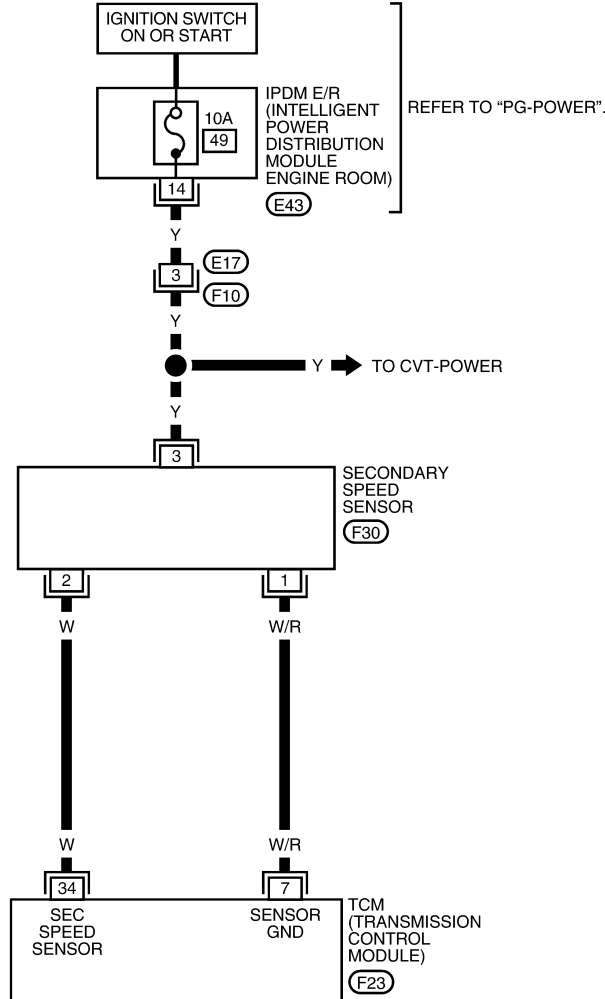

BCWA0740E

TCM TERMINALS AND REFERENCE VALUES
Refer to [CVT-45. "TCM Input/Output Signal Reference Value"](#).

DTC P0720 VEHICLE SPEED SENSOR CVT (SECONDARY SPEED SENSOR)

< SERVICE INFORMATION >

Diagnosis Procedure

INFOID:000000004407127

1. CHECK INPUT SIGNAL

④ With CONSULT-III

1. Start engine.
2. Select "ECU INPUT SIGNALS" in "DATA MONITOR" mode for "TRANSMISSION" with CONSULT-III.
3. Start vehicle and read out the value of "VSP SENSOR".

Item name	Condition	Display value
VSP SENSOR	During driving	Approximately matches the speedometer reading.

OK or NG

- OK >> GO TO 8.
NG >> GO TO 2.

2. CHECK SECONDARY SPEED SENSOR

④ With CONSULT-III

1. Start engine.
2. Check power supply to output speed sensor (secondary speed sensor) by voltage between TCM connector terminals 7, 46 and 48. Refer to [CVT-35. "Circuit Diagram"](#).

Item	Connector	Terminal	Data (Approx.)
TCM	F23	7- 46	Battery voltage
		7 - 48	

3. If OK, check the pulse when vehicle cruises.

Name	Condition
Output speed sensor (Secondary speed sensor)	When running at 20 km/h (12 MPH) in "D" position, use the CONSULT-III pulse frequency measuring function. CAUTION: Connect the data link connector to the vehicle-side diagnosis connector.

Item	Connector	Terminal	Name	Data (Approx.)
TCM	F23	34	Output speed sensor (Secondary speed sensor)	460 Hz

OK or NG

- OK >> GO TO 8.
NG >> GO TO 3.

3. CHECK POWER AND SENSOR GROUND

1. Turn ignition switch OFF.
2. Disconnect the output speed sensor (secondary speed sensor) harness connector.
3. Turn ignition switch ON.

DTC P0720 VEHICLE SPEED SENSOR CVT (SECONDARY SPEED SENSOR)

< SERVICE INFORMATION >

4. Check voltage between output speed sensor (secondary speed sensor) harness connector terminals.

Item	Connector	Terminal	Data (Approx.)
Output speed sensor (Secondary speed sensor)	F30	3 - 1	Battery voltage

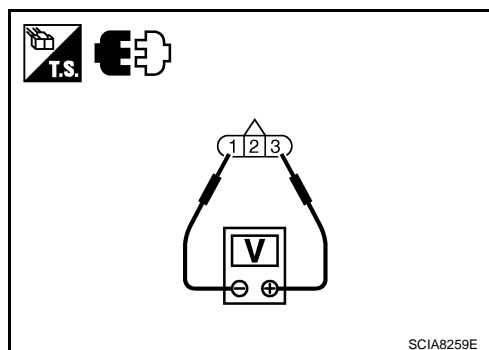

5. Check voltage between output speed sensor (secondary speed sensor) harness connector terminal and ground.

Item	Connector	Terminal	Data (Approx.)
Output speed sensor (Secondary speed sensor)	F30	3 - ground	Battery voltage

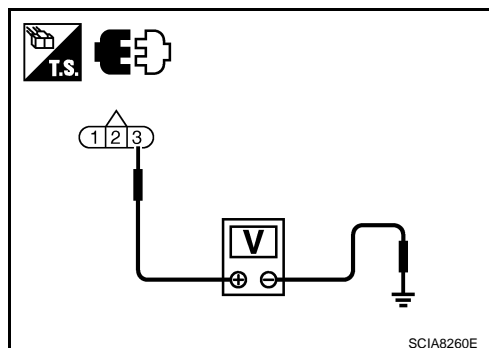

6. If OK, check harness for short to ground and short to power.
7. Reinstall any part removed.

OK or NG

OK >> GO TO 4.

NG - 1 >> Battery voltage is not supplied between terminals 1 and 3, terminals 1 and ground: GO TO 6.

NG - 2 >> Battery voltage is not supplied between terminals 1 and 3 only: GO TO 7.

4. CHECK HARNESS BETWEEN TCM AND OUTPUT SPEED SENSOR (SECONDARY SPEED SENSOR)

1. Turn ignition switch OFF.
2. Disconnect TCM connector (A) and output speed sensor (secondary speed sensor) harness connector (B).
3. Check continuity between TCM connector (A) terminal and output speed sensor (secondary speed sensor) harness connector (B) terminal.

Item	Connector	Terminal	Continuity
TCM	F23	34	Yes
Output speed sensor (Secondary speed sensor)	F30	2	

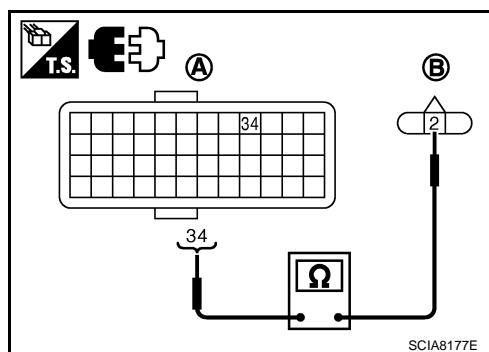

4. If OK, check harness for short to ground and short to power.
5. Reinstall any part removed.

OK or NG

OK >> GO TO 5.

NG >> Repair open circuit or short to ground or short to power in harness or connectors.

5. CHECK THE TCM SHORT

Replace same type TCM, perform self-diagnosis check. Erase self-diagnostic results and then drive the vehicle [more than 40 km/h (25 MPH)], perform self-diagnosis check. Refer to [CVT-76, "DTC Confirmation Procedure"](#).

Is "P0720 VEH SPD SEN/CIR CVT" detected again?

YES >> Replace the Secondary speed sensor. Refer to [CVT-183, "Secondary Speed Sensor"](#).

NO >> Replace TCM. Refer to [CVT-162, "Removal and Installation"](#).

6. CHECK HARNESS BETWEEN TCM AND OUTPUT SPEED SENSOR (SECONDARY SPEED SENSOR) (POWER)

1. Turn ignition switch OFF.
2. Disconnect TCM connector, IPDM E/R connector, input speed sensor (primary speed sensor) and output speed sensor (secondary speed sensor) harness connector.

DTC P0720 VEHICLE SPEED SENSOR CVT (SECONDARY SPEED SENSOR)

< SERVICE INFORMATION >

- Check continuity between TCM connector terminals, IPDM E/R harness connector terminal, input speed sensor (primary speed sensor) harness connector terminal and output speed sensor (secondary speed sensor) harness connector terminal. Refer to [CVT-35. "Circuit Diagram"](#).

Item	Connector	Terminal	Continuity
TCM*	F23	46, 48	Yes
IPDM E/R*	E43	14	
Input speed sensor (Primary speed sensor)*	F38	3	
Output speed sensor (Secondary speed sensor)*	F30	3	

*: Vehicle side

- If OK, check harness for short to ground and short to power.
- Reinstall any part removed.

OK or NG

- OK >> 10 A fuse (No. 49, located in the IPDM E/R) or ignition switch are malfunctioning.
 NG >> Repair open circuit or short to ground or short to power in harness or connectors.

7. CHECK HARNESS BETWEEN TCM AND OUTPUT SPEED SENSOR (SECONDARY SPEED SENSOR) (SENSOR GROUND)

- Turn ignition switch OFF.
- Disconnect TCM connector (A) and output speed sensor (secondary speed sensor) harness connector (B).
- Check continuity between TCM connector (A) terminal and output speed sensor (secondary speed sensor) harness connector (B) terminal.

Item	Connector	Terminal	Continuity
TCM	F23	7	Yes
Output speed sensor (Secondary speed sensor)	F30	1	

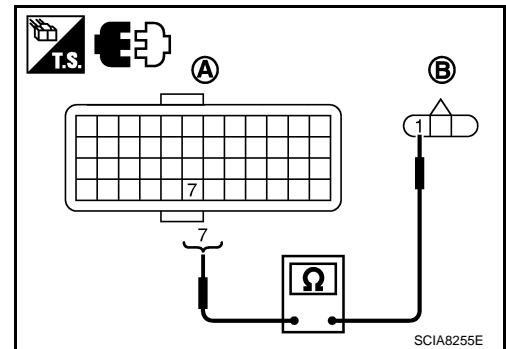

- If OK, check harness for short to ground and short to power.
- Reinstall any part removed.

OK or NG

- OK >> GO TO 8.
 NG >> Repair open circuit or short to ground or short to power in harness or connectors.

8. CHECK DTC

Perform [CVT-76. "DTC Confirmation Procedure"](#).

OK or NG

- OK >> **INSPECTION END**
 NG >> GO TO 9.

9. CHECK TCM

- Check TCM input/output signals. Refer to [CVT-45. "TCM Input/Output Signal Reference Value"](#).
- If NG, re-check TCM pin terminals for damage or loose connection with harness connector.

OK or NG

- OK >> **INSPECTION END**
 NG >> Repair or replace damaged parts.

DTC P0725 ENGINE SPEED SIGNAL

< SERVICE INFORMATION >

DTC P0725 ENGINE SPEED SIGNAL

Description

INFOID:000000004407128

The engine speed signal is sent from the ECM to the TCM.

CONSULT-III Reference Value

INFOID:000000004407129

Remarks: Specification data are reference values.

Item name	Condition	Display value
ENG SPEED SIG	Engine running	Closely matches the tachometer reading.
ACC PEDAL OPEN	Released accelerator pedal - Fully depressed accelerator pedal	0.0/8 - 8.0/8

On Board Diagnosis Logic

INFOID:000000004407130

- This is not an OBD-II self-diagnostic item.
- Diagnostic trouble code "P0725 ENGINE SPEED SIG" with CONSULT-III is detected when TCM does not receive the engine speed signal (input by CAN communication) from ECM.

Possible Cause

INFOID:000000004407131

Harness or connectors
(The ECM to the TCM circuit is open or shorted.)

DTC Confirmation Procedure

INFOID:000000004407132

CAUTION:

Always drive vehicle at a safe speed.

NOTE:

If "DTC Confirmation Procedure" has been previously performed, always turn ignition switch OFF and wait at least 10 seconds before performing the next test.

After the repair, touch "ERASE" on "SELF-DIAG RESULTS" and then perform the following procedure to confirm the malfunction is eliminated.

④ WITH CONSULT-III

1. Turn ignition switch ON and select "DATA MONITOR" mode for "TRANSMISSION" with CONSULT-III.
2. Start engine and maintain the following conditions for at least 10 consecutive seconds.
PRI SPEED SEN: More than 1000 rpm
3. If DTC is detected, go to [CVT-81, "Diagnosis Procedure"](#).

Diagnosis Procedure

INFOID:000000004407133

1. CHECK DTC WITH ECM

④ With CONSULT-III

1. Turn ignition switch ON.
2. Select "SELF-DIAG RESULTS" mode for "ENGINE" with CONSULT-III. Refer to [EC-123, "CONSULT-III Function \(ENGINE\)"](#).

OK or NG

- OK >> GO TO 2.
NG >> Check the DTC detected item. Refer to [EC-123, "CONSULT-III Function \(ENGINE\)"](#).

2. CHECK DTC WITH TCM

④ With CONSULT-III

1. Turn ignition switch ON.
2. Select "SELF-DIAG RESULTS" mode for "TRANSMISSION" with CONSULT-III. Refer to [CVT-47, "CONSULT-III Function \(TRANSMISSION\)"](#).

OK or NG

- OK >> GO TO 3.
NG >> Check the DTC detected item. Refer to [CVT-47, "CONSULT-III Function \(TRANSMISSION\)"](#).

DTC P0725 ENGINE SPEED SIGNAL

< SERVICE INFORMATION >

- If DTC of CAN communication line is detected, go to [CVT-55](#).

3. CHECK INPUT SIGNALS

With CONSULT-III

1. Start engine.
2. Select "ECU INPUT SIGNALS" in "DATA MONITOR" mode for "TRANSMISSION" with CONSULT-III.
3. While monitoring "ENG SPEED SIG", check for engine speed change corresponding to "ACC PEDAL OPEN".

Item name	Condition	Display value
ENG SPEED SIG	Engine running	Closely matches the tachometer reading.
ACC PEDAL OPEN	Released accelerator pedal - Fully depressed accelerator pedal	0.0/8 - 8.0/8

OK or NG

- OK >> GO TO 4.
NG >> Check ignition signal circuit. Refer to [EC-551](#).

4. CHECK DTC

Perform [CVT-81. "DTC Confirmation Procedure"](#).

OK or NG

- OK >> **INSPECTION END**
NG >> GO TO 5.

5. CHECK TCM

1. Check TCM input/output signals. Refer to [CVT-45. "TCM Input/Output Signal Reference Value"](#).
2. If NG, re-check TCM pin terminals for damage or loose connection with harness connector.

OK or NG

- OK >> **INSPECTION END**
NG >> Repair or replace damaged parts.

DTC P0730 BELT DAMAGE

< SERVICE INFORMATION >

DTC P0730 BELT DAMAGE

Description

INFOID:000000004407134

TCM selects the gear ratio using the engine load (throttle position), the primary pulley revolution speed, and the secondary pulley revolution speed as input signal. Then it changes the operating pressure of the primary pulley and the secondary pulley and changes the groove width of the pulley.

CONSULT-III Reference Value

INFOID:000000004407135

Remarks: Specification data are reference values.

Item name	Condition	Display value (Approx.)
GEAR RATIO	During driving	2.34 - 0.39

On Board Diagnosis Logic

INFOID:000000004407136

- This is not an OBD-II self-diagnostic item.
- TCM calculates the actual gear ratio with input speed sensor (primary speed sensor) and output speed sensor (secondary speed sensor).
- Diagnostic trouble code "P0730 BELT DAMG" with CONSULT-III is detected, when TCM receives an unexpected gear ratio signal.

Possible Cause

INFOID:000000004407137

Transaxle assembly

DTC Confirmation Procedure

INFOID:000000004407138

CAUTION:

Always drive vehicle at a safe speed.

NOTE:

If "DTC Confirmation Procedure" has been previously performed, always turn ignition switch OFF and wait at least 10 seconds before performing the next test.

After the repair, perform the following procedure to confirm the malfunction is eliminated.

Ⓟ WITH CONSULT-III

1. Turn ignition switch ON and select "DATA MONITOR" mode for "TRANSMISSION" with CONSULT-III.
2. Make sure that output voltage of CVT fluid temperature sensor is within the range below.
ATF TEMP SEN: 1.0 - 2.0 V
If out of range, drive the vehicle to decrease the voltage (warm up the fluid) or stop engine to increase the voltage (cool down the fluid)
3. Select "DATA MONITOR" mode for "TRANSMISSION" with CONSULT-III.
4. Start engine and maintain the following conditions for at least 30 consecutive seconds.
TEST START FROM 0 km/h (0 MPH)
CONSTANT ACCELERATION: Keep 30 sec or more
VEHICLE SPEED: 10 km/h (6 MPH) or more
ACC PEDAL OPEN: More than 1.0/8
RANGE: "D" position
ENG SPEED: 450 rpm or more
5. If DTC is detected, go to [CVT-83, "Diagnosis Procedure"](#).

Diagnosis Procedure

INFOID:000000004407139

1. CHECK DTC

Perform [CVT-83, "DTC Confirmation Procedure"](#).

Are any DTC displayed?

YES - 1>> DTC except for "P0730 BELT DAMG" is displayed: Go to Check the DTC detected item. Refer to [CVT-47, "CONSULT-III Function \(TRANSMISSION\)"](#).

YES - 2>> DTC for "P0730 BELT DAMG" is displayed: Replace the transaxle assembly. Refer to [CVT-190, "Removal and Installation \(MR20DE\)"](#).

NO >> **INSPECTION END**

DTC P0740 TORQUE CONVERTER CLUTCH SOLENOID VALVE

< SERVICE INFORMATION >

DTC P0740 TORQUE CONVERTER CLUTCH SOLENOID VALVE

Description

INFOID:000000004407140

- The torque converter clutch solenoid valve is activated by the TCM in response to signals sent from the vehicle speed and accelerator pedal position sensors. Lock-up piston operation will then be controlled.
- Lock-up operation, however, is prohibited when CVT fluid temperature is too low.
- When the accelerator pedal is depressed (less than 2.0/8) in lock-up condition, the engine speed should not change abruptly. If there is a big jump in engine speed, there is no lock-up.

CONSULT-III Reference Value

INFOID:000000004407141

Remarks: Specification data are reference values.

Item name	Condition	Display value (Approx.)
ISOLT1	Lock-up OFF	0.0 A
	Lock-up ON	0.7 A

On Board Diagnosis Logic

INFOID:000000004407142

- This is an OBD-II self-diagnostic item.
- Diagnostic trouble code "P0740 TCC SOLENOID/CIRC" with CONSULT-III is detected under the following conditions.
 - TCM detects an improper voltage drop when it tries to operate the solenoid valve.

Possible Cause

INFOID:000000004407143

- Torque converter clutch solenoid valve
- Harness or connectors
(Solenoid circuit is open or shorted.)

DTC Confirmation Procedure

INFOID:000000004407144

NOTE:

If "DTC Confirmation Procedure" has been previously performed, always turn ignition switch OFF and wait at least 10 seconds before performing the next test.

After the repair, touch "ERASE" on "SELF-DIAG RESULTS" and then perform the following procedure to confirm the malfunction is eliminated.

④ WITH CONSULT-III

1. Turn ignition switch ON.
2. Select "DATA MONITOR" mode for "TRANSMISSION" with CONSULT-III and wait at least 10 consecutive seconds.
3. If DTC is detected, go to [CVT-86, "Diagnosis Procedure"](#).

④ WITH GST

Follow the procedure "WITH CONSULT-III".

DTC P0740 TORQUE CONVERTER CLUTCH SOLENOID VALVE

< SERVICE INFORMATION >

Wiring Diagram - CVT - TCV

INFOID:000000004407145

CVT-TCV-01

: DETECTABLE LINE FOR DTC
 : NON-DETECTABLE LINE FOR DTC

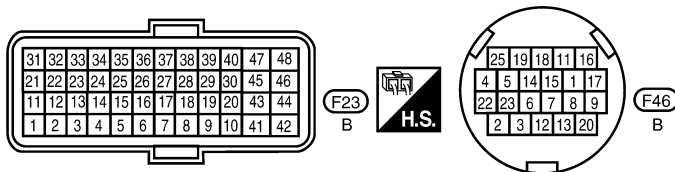
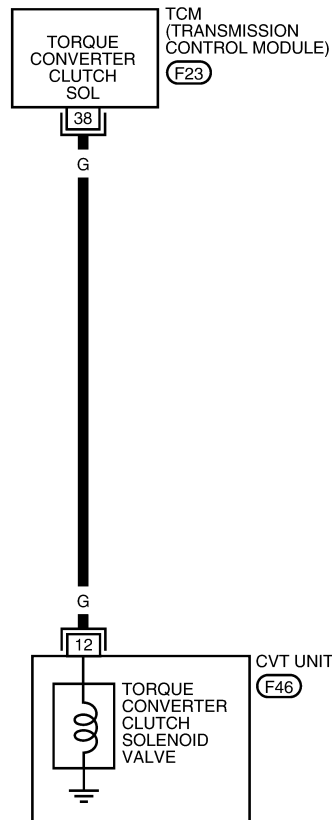

BCWA0741E

TCM TERMINALS AND REFERENCE VALUES

Refer to [CVT-45, "TCM Input/Output Signal Reference Value"](#).

DTC P0740 TORQUE CONVERTER CLUTCH SOLENOID VALVE

< SERVICE INFORMATION >

Diagnosis Procedure

INFOID:000000004407146

1. CHECK INPUT SIGNAL

With CONSULT-III

1. Start engine.
2. Select "MAIN SIGNALS" in "DATA MONITOR" mode for "TRANSMISSION" with CONSULT-III.
3. Start vehicle and read out the value of "ISOLT1".

Item name	Condition	Display value (Approx.)
ISOLT1	Lock-up OFF	0.0 A
	Lock-up ON	0.7 A

Without CONSULT-III

1. Start engine.
2. Check voltage between TCM connector terminal and ground.

Name	Connector	Terminal	Condition	Voltage (Approx.)	
Torque converter clutch solenoid valve	F23	38 - ground	When vehicle cruises in "D" position	Lock-up ON	6.0 V
			Lock-up OFF	1.5 V	

3. Turn ignition switch OFF.
4. Disconnect TCM connector.
5. Check if there is continuity between the connector terminal and ground.

OK or NG

- OK >> GO TO 5.
NG >> GO TO 2.

2. CHECK TORQUE CONVERTER CLUTCH SOLENOID VALVE CIRCUIT

1. Turn ignition switch OFF.
2. Disconnect TCM connector.
3. Check resistance between TCM connector terminal and ground.

Solenoid valve	Connector	Terminal	Resistance (Approx.)
Torque converter clutch solenoid valve	F23	38 - Ground	3 - 9 Ω

OK or NG

- OK >> GO TO 5.
NG >> GO TO 3.

3. CHECK HARNESS BETWEEN TCM AND TORQUE CONVERTER CLUTCH SOLENOID VALVE

1. Turn ignition switch OFF.
2. Disconnect TCM connector (A) and CVT unit harness connector (B).

DTC P0740 TORQUE CONVERTER CLUTCH SOLENOID VALVE

< SERVICE INFORMATION >

- Check continuity between TCM connector terminal (A) and CVT unit harness connector terminal (B).

Item	Connector	Terminal	Continuity
TCM	F23	38	Yes
CVT unit harness connector	F46	12	

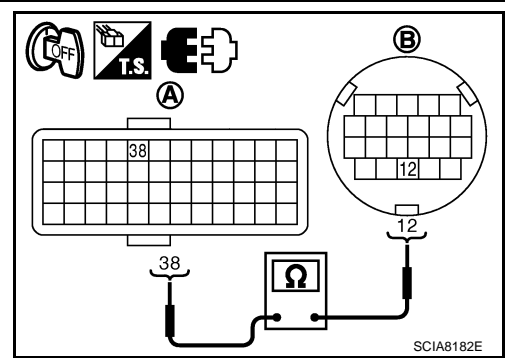

- If OK, check harness for short to ground and short to power.
- If OK, check continuity between ground and CVT assembly.
- Reinstall any part removed.

OK or NG

- OK >> GO TO 4.
- NG >> Repair or replace damaged parts.

4.CHECK VALVE RESISTANCE

- Turn ignition switch OFF.
- Disconnect CVT unit harness connector.
- Check resistance between CVT unit harness connector terminal and ground.

Solenoid Valve	Connector	Terminal	Resistance (Approx.)
Torque converter clutch solenoid valve	F46	12 - Ground	3 - 9 Ω

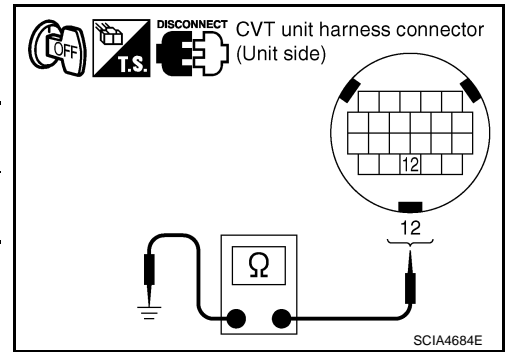

OK or NG

- OK >> GO TO 5.
- NG >> Repair or replace damaged parts.

5.CHECK DTC

Perform [CVT-84, "DTC Confirmation Procedure"](#).

OK or NG

- OK >> **INSPECTION END**
- NG >> GO TO 6.

6.CHECK TCM

- Check TCM input/output signals. Refer to [CVT-45, "TCM Input/Output Signal Reference Value"](#).
- If NG, re-check TCM pin terminals for damage or loose connection with harness connector.

OK or NG

- OK >> **INSPECTION END**
- NG >> Repair or replace damaged parts.

Component Inspection

INFOID:000000004407147

TORQUE CONVERTER CLUTCH SOLENOID VALVE

- Turn ignition switch OFF.
- Disconnect CVT unit harness connector.

DTC P0740 TORQUE CONVERTER CLUTCH SOLENOID VALVE

< SERVICE INFORMATION >

3. Check resistance between CVT unit harness connector terminal and ground.

Solenoid Valve	Connector	Terminal	Resistance (Approx.)
Torque converter clutch solenoid valve	F46	12 - Ground	3 - 9 Ω

4. If NG, replace the transaxle assembly. Refer to [CVT-190](#), "[Removal and Installation \(MR20DE\)](#)".

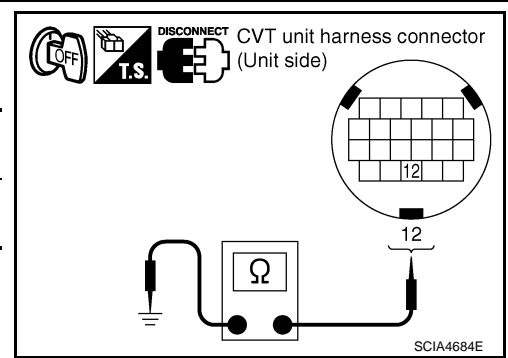

DTC P0744 A/T TCC S/V FUNCTION (LOCK-UP)

< SERVICE INFORMATION >

DTC P0744 A/T TCC S/V FUNCTION (LOCK-UP)

Description

INFOID:000000004407148

- This malfunction is detected when the torque converter clutch does not lock-up as instructed by the TCM. This is not only caused by electrical malfunction (circuits open or shorted), but also by mechanical malfunction such as control valve sticking, improper solenoid valve operation, etc.

CONSULT-III Reference Value

INFOID:000000004407149

Remarks: Specification data are reference values.

Item name	Condition	Display value
ENG SPEED SIG	Engine running	Closely matches the tachometer reading.
PRI SPEED SEN	During driving (lock-up ON)	Approximately matches the engine speed.

On Board Diagnosis Logic

INFOID:000000004407150

- This is an OBD-II self-diagnostic item.
- Diagnostic trouble code "P0744 A/T TCC S/V FNCTN" with CONSULT-III is detected under the following conditions.
 - When CVT cannot perform lock-up even if electrical circuit is good.
 - When TCM compares difference value with slip revolution and detects an irregularity.

Possible Cause

INFOID:000000004407151

- Torque converter clutch solenoid valve
- Hydraulic control circuit

DTC Confirmation Procedure

INFOID:000000004407152

CAUTION:

Always drive vehicle at a safe speed.

NOTE:

If "DTC Confirmation Procedure" has been previously performed, always turn ignition switch OFF and wait at least 10 seconds before performing the next test.

After the repair, touch "ERASE" on "SELF-DIAG RESULTS" and then perform the following procedure to confirm the malfunction is eliminated.

Ⓜ WITH CONSULT-III

1. Turn ignition switch ON.
2. Select "DATA MONITOR" mode for "TRANSMISSION" with CONSULT-III.
3. Start engine and maintain the following condition for at least 30 seconds.

ACC PEDAL OPEN: More than 1.0/8

RANGE: "D" position

[Vehicle speed: Constant speed of more than 40 km/h (25 MPH)]

4. If DTC is detected go to [CVT-89, "Diagnosis Procedure"](#).

Ⓜ WITH GST

Follow the procedure "WITH CONSULT-III".

Diagnosis Procedure

INFOID:000000004407153

1. CHECK INPUT SIGNALS

Ⓜ With CONSULT-III

1. Start engine.
2. Select "ECU INPUT SIGNALS" in "DATA MONITOR" mode for "TRANSMISSION" with CONSULT-III.
3. Start vehicle.
4. Check if there is a great difference between "ENG SPEED SIG" and "PRI SPEED SEN". (Lock-up ON.)

DTC P0744 A/T TCC S/V FUNCTION (LOCK-UP)

< SERVICE INFORMATION >

Item name	Condition	Display value
ENG SPEED SIG	Engine running	Closely matches the tachometer reading.
PRI SPEED SEN	During driving (lock-up ON)	Approximately matches the engine speed.

OK or NG

- OK >> GO TO 5.
NG >> GO TO 2.

2.CHECK LINE PRESSURE

Perform line pressure test. Refer to [CVT-36, "Inspections before Trouble Diagnosis"](#).

OK or NG

- OK >> GO TO 3.
NG >> Repair or replace damaged parts. Refer to [CVT-36, "Inspections before Trouble Diagnosis"](#).

3.DETECT MALFUNCTIONING ITEM

Check the following:

- Torque converter clutch solenoid valve. Refer to [CVT-87, "Component Inspection"](#).
- Lock-up select solenoid valve. Refer to [CVT-132, "Component Inspection"](#).

OK or NG

- OK >> GO TO 4.
NG >> Repair or replace damaged parts.

4.CHECK OUTPUT SPEED SENSOR (SECONDARY SPEED SENSOR) SYSTEM AND INPUT SPEED SENSOR (PRIMARY SPEED SENSOR) SYSTEM

Check output speed sensor (secondary speed sensor) system and input speed sensor (primary speed sensor) system. Refer to [CVT-76, CVT-71](#).

OK or NG

- OK >> GO TO 5.
NG >> Repair or replace damaged parts.

5.CHECK DTC

Perform [CVT-89, "DTC Confirmation Procedure"](#).

OK or NG

- OK >> **INSPECTION END**
NG >> GO TO 6.

6.CHECK TCM

1. Check TCM input/output signals. Refer to [CVT-45, "TCM Input/Output Signal Reference Value"](#).
2. If NG, re-check TCM pin terminals for damage or loose connection with harness connector.

OK or NG

- OK >> **INSPECTION END**
NG >> 1. Repair or replace damaged parts.
2. Replace the transaxle assembly. Refer to [CVT-190, "Removal and Installation \(MR20DE\)"](#).

DTC P0745 LINE PRESSURE SOLENOID VALVE

< SERVICE INFORMATION >

DTC P0745 LINE PRESSURE SOLENOID VALVE

Description

INFOID:000000004407154

- The pressure control solenoid valve A (line pressure solenoid valve) regulates the oil pump discharge pressure to suit the driving condition in response to a signal sent from the TCM.

CONSULT-III Reference Value

INFOID:000000004407155

Remarks: Specification data are reference values.

Item name	Condition	Display value (Approx.)
ISOLT2	Release your foot from the accelerator pedal	0.8 A
	Press the accelerator pedal all the way down	0.0 A

On Board Diagnosis Logic

INFOID:000000004407156

- This is an OBD-II self-diagnostic item.
- Diagnostic trouble code "P0745 L/PRESS SOL/CIRC" with CONSULT-III is detected under the following conditions.
 - TCM detects an improper voltage drop when it tries to operate the solenoid valve.
 - When TCM compares target value with monitor value and detects an irregularity.

Possible Cause

INFOID:000000004407157

- Harness or connectors
(Solenoid circuit is open or shorted.)
- Pressure control solenoid valve A (Line pressure solenoid valve)

DTC Confirmation Procedure

INFOID:000000004407158

NOTE:

If "DTC Confirmation Procedure" has been previously performed, always turn ignition switch OFF and wait at least 10 seconds before performing the next test.

After the repair, perform the following procedure to confirm the malfunction is eliminated.

Ⓔ WITH CONSULT-III

1. Turn ignition switch ON and select "DATA MONITOR" mode for "TRANSMISSION" with CONSULT-III.
2. Start engine and wait at least 5 seconds.
3. If DTC is detected, go to [CVT-93, "Diagnosis Procedure"](#).

Ⓔ WITH GST

Follow the procedure "WITH CONSULT-III".

DTC P0745 LINE PRESSURE SOLENOID VALVE

< SERVICE INFORMATION >

Wiring Diagram - CVT - LPSV

INFOID:000000004407159

CVT-LPSV-01

— : DETECTABLE LINE FOR DTC
— : NON-DETECTABLE LINE FOR DTC

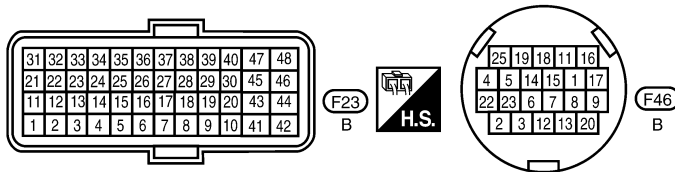
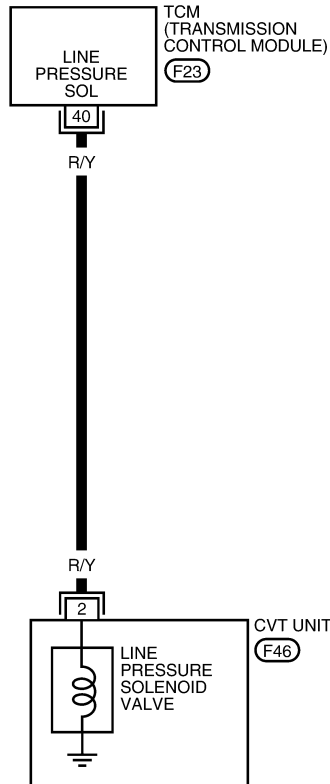

BCWA0742E

TCM TERMINALS AND REFERENCE VALUES

Refer to [CVT-45, "TCM Input/Output Signal Reference Value"](#).

DTC P0745 LINE PRESSURE SOLENOID VALVE

< SERVICE INFORMATION >

Diagnosis Procedure

INFOID:000000004407160

1. CHECK INPUT SIGNAL

With CONSULT-III

1. Start engine.
2. Select "MAIN SIGNALS" in "DATA MONITOR" mode for "TRANSMISSION" with CONSULT-III.
3. Read out the value of "ISOLT2".

Item name	Condition	Display value (Approx.)
ISOLT2	Release your foot from the accelerator pedal.	0.8 A
	Press the accelerator pedal all the way down.	0.0 A

Without CONSULT-III

1. Start engine.
2. Check voltage between TCM connector terminal and ground.

Name	Connector	Terminal	Condition	Voltage (Approx.)
Pressure control solenoid valve A (Line pressure solenoid valve)	F23	40 - ground	Release your foot from the accelerator pedal.	5.0 - 7.0 V
			Press the accelerator pedal all the way down.	1.0 V

3. Turn ignition switch OFF.
4. Disconnect TCM connector.
5. Check if there is continuity between connector terminal and ground.

OK or NG

- OK >> GO TO 5.
NG >> GO TO 2.

2. CHECK PRESSURE CONTROL SOLENOID VALVE A (LINE PRESSURE SOLENOID VALVE) CIRCUIT

1. Turn ignition switch OFF.
2. Disconnect TCM connector.
3. Check resistance between TCM connector terminal and ground.

Solenoid valve	Connector	Terminal	Resistance (Approx.)
Pressure control solenoid valve A (Line pressure solenoid valve)	F23	40 - ground	3.0 - 9.0 Ω

OK or NG

- OK >> GO TO 5.
NG >> GO TO 3.

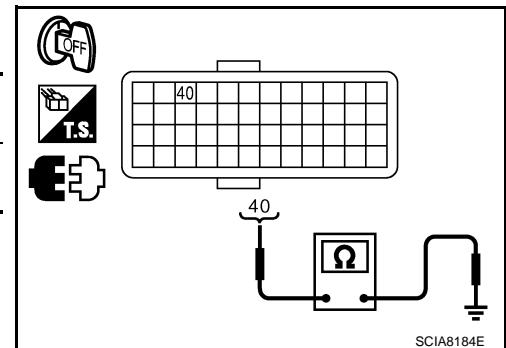

3. CHECK VALVE RESISTANCE

1. Turn ignition switch OFF.
2. Disconnect CVT unit harness connector.

DTC P0745 LINE PRESSURE SOLENOID VALVE

< SERVICE INFORMATION >

- Check resistance between CVT unit harness connector terminal and ground.

Solenoid valve	Connector	Terminal	Resistance (Approx.)
Pressure control solenoid valve A (Line pressure solenoid valve)	F46	2 - Ground	3.0 - 9.0 Ω

OK or NG

- OK >> GO TO 4.
 NG >> Replace the transaxle assembly. Refer to [CVT-190, "Removal and Installation \(MR20DE\)"](#).

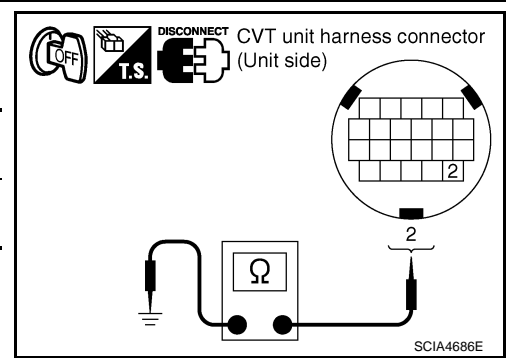

4. CHECK HARNESS BETWEEN TCM AND PRESSURE CONTROL SOLENOID VALVE A (LINE PRESSURE SOLENOID VALVE)

- Turn ignition switch OFF.
- Disconnect CVT unit harness connector (B) and TCM connector (A).
- Check continuity between TCM connector (A) terminal and CVT unit harness connector (B) terminal.

Item	Connector	Terminal	Continuity
TCM	F23	40	Yes
CVT unit harness connector	F46	2	

- If OK, check harness for short to ground and short to power.
- If OK, check continuity between ground and CVT assembly.
- Reinstall any part removed.

OK or NG

- OK >> GO TO 5.
 NG >> Repair open circuit or short to ground or short to power in harness or connectors.

5. CHECK DTC

Perform [CVT-91, "DTC Confirmation Procedure"](#).

OK or NG

- OK >> **INSPECTION END**
 NG >> GO TO 6.

6. CHECK TCM

- Check TCM input/output signals. Refer to [CVT-45, "TCM Input/Output Signal Reference Value"](#).
- If NG, re-check TCM pin terminals for damage or loose connection with harness connector.

OK or NG

- OK >> **INSPECTION END**
 NG >> 1. Repair or replace damaged parts.
 2. Replace the transaxle assembly. Refer to [CVT-190, "Removal and Installation \(MR20DE\)"](#).

Component Inspection

INFOID:000000004407161

PRESSURE CONTROL SOLENOID VALVE A (LINE PRESSURE SOLENOID VALVE)

- Turn ignition switch OFF.
- Disconnect CVT unit harness connector.

DTC P0745 LINE PRESSURE SOLENOID VALVE

< SERVICE INFORMATION >

3. Check resistance between CVT unit harness connector terminal and ground.

Solenoid valve	Connector	Terminal	Resistance (Approx.)
Pressure control solenoid valve A (Line pressure solenoid valve)	F46	2 - Ground	3.0 - 9.0 Ω

4. If NG, replace the transaxle assembly. Refer to [CVT-190](#), "[Removal and Installation \(MR20DE\)](#)".

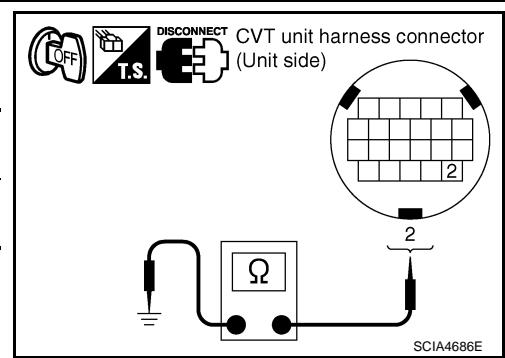

A

B

CVT

D

E

F

G

H

I

J

K

L

M

N

O

P

DTC P0746 PRESSURE CONTROL SOLENOID A PERFORMANCE (LINE PRESSURE SOLENOID VALVE)

< SERVICE INFORMATION >

DTC P0746 PRESSURE CONTROL SOLENOID A PERFORMANCE (LINE PRESSURE SOLENOID VALVE)

Description

INFOID:000000004407162

- The pressure control solenoid valve A (line pressure solenoid valve) regulates the oil pump discharge pressure to suit the driving condition in response to a signal sent from the TCM.

CONSULT-III Reference Value

INFOID:000000004407163

Remarks: Specification data are reference values.

Item name	Condition	Display value (Approx.)
PRI PRESS	"N" position idle	0.3 - 0.7 MPa

On Board Diagnosis Logic

INFOID:000000004407164

- This is an OBD-II self-diagnostic item.
- Diagnostic trouble code "P0746 PRS CNT SOL/A FCTN" with CONSULT-III is detected under the following conditions.
 - Unexpected gear ratio was detected in the LOW side due to excessively low line pressure.

Possible Cause

INFOID:000000004407165

- Line pressure control system
- Output speed sensor (Secondary speed sensor)
- Input speed sensor (Primary speed sensor)

DTC Confirmation Procedure

INFOID:000000004407166

CAUTION:

Always drive vehicle at a safe speed.

NOTE:

If "DTC Confirmation Procedure" has been previously performed, always turn ignition switch OFF and wait at least 10 seconds before performing the next test.

After the repair, touch "ERASE" on "SELF-DIAG RESULTS" and then perform the following procedure to confirm the malfunction is eliminated.

Ⓜ WITH CONSULT-III

1. Turn ignition switch ON and select "DATA MONITOR" mode for "TRANSMISSION" with CONSULT-III.
2. Start engine and maintain the following conditions for at least 10 consecutive seconds. Test start from 0 km/h (0 MPH).

ATF TEMP SEN: 1.0 - 2.0 V

ACC PEDAL OPEN: More than 1.0/8

RANGE: "D" position

VEHICLE SPEED: 10 km/h (6 MPH) More than

Driving location: Driving the vehicle uphill (increased engine load) will help maintain the driving conditions required for this test.

3. If DTC is detected, go to [CVT-96, "Diagnosis Procedure"](#).

Ⓜ WITH GST

Follow the procedure "WITH CONSULT-III".

Diagnosis Procedure

INFOID:000000004407167

1. CHECK INPUT SIGNAL

Ⓜ With CONSULT-III

1. Start engine.
2. Select "MAIN SIGNALS" in "DATA MONITOR" mode for "TRANSMISSION" with CONSULT-III.
3. Start vehicle and read out the value of "PRI PRESS".

DTC P0746 PRESSURE CONTROL SOLENOID A PERFORMANCE (LINE PRESSURE SOLENOID VALVE)

< SERVICE INFORMATION >

Item name	Condition	Display value (Approx.)
PRI PRESS	"N" position idle	0.3 - 0.7 MPa

⊗ Without CONSULT-III

1. Start engine.
2. Check voltage between TCM connector terminal and ground.

Name	Connector	Terminal	Condition	Voltage (Approx.)
Transmission fluid pressure sensor B (Primary pressure sensor)	F23	14 - Ground	"N" position idle	0.7 - 3.5 V

OK or NG

- OK >> GO TO 5.
NG >> GO TO 2.

2.CHECK LINE PRESSURE

Perform line pressure test. Refer to [CVT-36, "Inspections before Trouble Diagnosis"](#).

OK or NG

- OK >> GO TO 3.
NG >> Repair or replace damaged parts. Refer to [CVT-36, "Inspections before Trouble Diagnosis"](#).

3.DETECT MALFUNCTIONING ITEM

Check pressure control solenoid valve A (line pressure solenoid valve). Refer to [CVT-94, "Component Inspection"](#).

OK or NG

- OK >> GO TO 4.
NG >> Repair or replace damaged parts.

4.CHECK OUTPUT SPEED SENSOR (SECONDARY SPEED SENSOR) SYSTEM AND INPUT SPEED SENSOR (PRIMARY SPEED SENSOR) SYSTEM

Check output speed sensor (secondary speed sensor) system and input speed sensor (primary speed sensor) system. Refer to [CVT-76, CVT-71](#).

OK or NG

- OK >> GO TO 5.
NG >> Repair or replace damaged parts.

5.DETECT MALFUNCTIONING ITEM

Check the following:

- Power supply and ground circuit for TCM. Refer to [CVT-119, "Wiring Diagram - CVT - POWER"](#).
- The TCM pin terminals for damage or loose connection with harness connector.

OK or NG

- OK >> GO TO 6.
NG >> Repair or replace damaged parts.

6.CHECK DTC

Perform [CVT-96, "DTC Confirmation Procedure"](#).

OK or NG

- OK >> **INSPECTION END**
NG >> Replace the transaxle assembly or TCM. Refer to [CVT-190, "Removal and Installation \(MR20DE\)"](#).

DTC P0776 PRESSURE CONTROL SOLENOID B PERFORMANCE (SEC PRESSURE SOLENOID VALVE)

< SERVICE INFORMATION >

DTC P0776 PRESSURE CONTROL SOLENOID B PERFORMANCE (SEC PRESSURE SOLENOID VALVE)

Description

INFOID:000000004407168

- The pressure control solenoid valve B (secondary pressure solenoid valve) regulates the secondary pressure to suit the driving condition in response to a signal sent from the TCM.

CONSULT-III Reference Value

INFOID:000000004407169

Remarks: Specification data are reference values.

Item name	Condition	Display value (Approx.)
SEC PRESS	"N" position idle	0.5 MPa

On Board Diagnosis Logic

INFOID:000000004407170

- This is an OBD-II self-diagnostic item.
- Diagnostic trouble code "P0776 PRS CNT SOL/B FCTN" with CONSULT-III is detected when secondary pressure is too high or too low compared with the commanded value while driving.

Possible Cause

INFOID:000000004407171

- Harness or connectors
(Solenoid circuit is open or shorted.)
- Pressure control solenoid valve B (Secondary pressure solenoid valve system)
- Transmission fluid pressure sensor A (Secondary pressure sensor)
- Line pressure control system

DTC Confirmation Procedure

INFOID:000000004407172

CAUTION:

Always drive vehicle at a safe speed.

NOTE:

If "DTC Confirmation Procedure" has been previously performed, always turn ignition switch OFF and wait at least 10 seconds before performing the next test.

After the repair, perform the following procedure to confirm the malfunction is eliminated.

Ⓜ WITH CONSULT-III

1. Turn ignition switch ON and select "DATA MONITOR" mode for "TRANSMISSION" with CONSULT-III.
2. Start engine and maintain the following conditions for at least 30 consecutive seconds.
ATF TEMP SEN: 1.0 - 2.0 V
ACC PEDAL OPEN: More than 1.0/8
RANGE: "D" position
VEHICLE SPEED: 10 km/h (6 MPH) More than
Driving location: Driving the vehicle uphill (increased engine load) will help maintain the driving conditions required for this test.
3. If DTC is detected, go to [CVT-98, "Diagnosis Procedure"](#).

Ⓜ WITH GST

Follow the procedure "WITH CONSULT-III".

Diagnosis Procedure

INFOID:000000004407173

1. CHECK INPUT SIGNAL

Ⓜ With CONSULT-III

1. Start engine.
2. Select "MAIN SIGNALS" in "DATA MONITOR" mode for "TRANSMISSION" with CONSULT-III.
3. Start vehicle and read out the value of "SEC PRESS".

DTC P0776 PRESSURE CONTROL SOLENOID B PERFORMANCE (SEC PRESSURE SOLENOID VALVE)

< SERVICE INFORMATION >

Item name	Condition	Display value (Approx.)
SEC PRESS	"N" position idle	0.5 MPa

OK or NG

- OK >> GO TO 5.
- NG >> GO TO 2.

2.CHECK LINE PRESSURE

Perform line pressure test. Refer to [CVT-36. "Inspections before Trouble Diagnosis"](#).

OK or NG

- OK >> GO TO 3.
- NG >> Repair or replace damaged parts. Refer to [CVT-36. "Inspections before Trouble Diagnosis"](#).

3.DETECT MALFUNCTIONING ITEM

Check the following:

- Pressure control solenoid valve B (Secondary pressure solenoid valve). Refer to [CVT-103. "Component Inspection"](#).
- Pressure control solenoid valve A (Line pressure solenoid valve). Refer to [CVT-94. "Component Inspection"](#).

OK or NG

- OK >> GO TO 4.
- NG >> Repair or replace damaged parts.

4.CHECK TRANSMISSION FLUID PRESSURE SENSOR A (SECONDARY PRESSURE SENSOR) SYSTEM

Check transmission fluid pressure sensor A (secondary pressure sensor) system. Refer to [CVT-110](#).

OK or NG

- OK >> GO TO 5.
- NG >> Repair or replace damaged parts.

5.DETECT MALFUNCTIONING ITEM

Check the following:

- Power supply and ground circuit for TCM. Refer to [CVT-119. "Wiring Diagram - CVT - POWER"](#).
- The TCM pin terminals for damage or loose connection with harness connector.

OK or NG

- OK >> GO TO 6.
- NG >> Repair or replace damaged parts.

6.CHECK DTC

Perform [CVT-98. "DTC Confirmation Procedure"](#).

OK or NG

- OK >> **INSPECTION END**
- NG >> Replace the transaxle assembly. Refer to [CVT-190. "Removal and Installation \(MR20DE\)"](#).

A
B
CVT
D
E
F
G
H
I
J
K
L
M
N
O
P

DTC P0778 PRESSURE CONTROL SOLENOID B ELECTRICAL (SEC PRESSURE SOLENOID VALVE)

< SERVICE INFORMATION >

DTC P0778 PRESSURE CONTROL SOLENOID B ELECTRICAL (SEC PRESSURE SOLENOID VALVE)

Description

INFOID:000000004407174

- The pressure control solenoid valve B (secondary pressure solenoid valve) regulates the oil pump discharge pressure to suit the driving condition in response to a signal sent from the TCM.

CONSULT-III Reference Value

INFOID:000000004407175

Remarks: Specification data are reference values.

Item name	Condition	Display value (Approx.)
ISOLT3	Secondary pressure low - Secondary pressure high	0.8 - 0.0 A
SOLMON3	"N" position idle	0.6 - 0.7 A
	When stalled	0.4 - 0.6 A

On Board Diagnosis Logic

INFOID:000000004407176

- This is an OBD-II self-diagnostic item.
- Diagnostic trouble code "P0778 PRS CNT SOL/B CIRC" with CONSULT-III is detected under the following conditions.
 - TCM detects an improper voltage drop when it tries to operate the solenoid valve.
 - When TCM compares target value with monitor value and detects an irregularity.

Possible Cause

INFOID:000000004407177

- Harness or connectors
(Solenoid circuit is open or shorted.)
- Pressure control solenoid valve B (Secondary pressure solenoid valve)

DTC Confirmation Procedure

INFOID:000000004407178

NOTE:

If "DTC Confirmation Procedure" has been previously performed, always turn ignition switch OFF and wait at least 10 seconds before performing the next test.

After the repair, perform the following procedure to confirm the malfunction is eliminated.

WITH CONSULT-III

1. Turn ignition switch ON.
2. Select "DATA MONITOR" mode for "TRANSMISSION" with CONSULT-III.
3. Start engine and wait at least 5 seconds.
4. If DTC is detected, go to [CVT-102, "Diagnosis Procedure"](#).

WITH GST

Follow the procedure "WITH CONSULT-III".

DTC P0778 PRESSURE CONTROL SOLENOID B ELECTRICAL (SEC PRES- SURE SOLENOID VALVE)

< SERVICE INFORMATION >

Wiring Diagram - CVT - SECPSV

INFOID:000000004407179

CVT-SECPSV-01

— : DETECTABLE LINE FOR DTC
 — : NON-DETECTABLE LINE FOR DTC

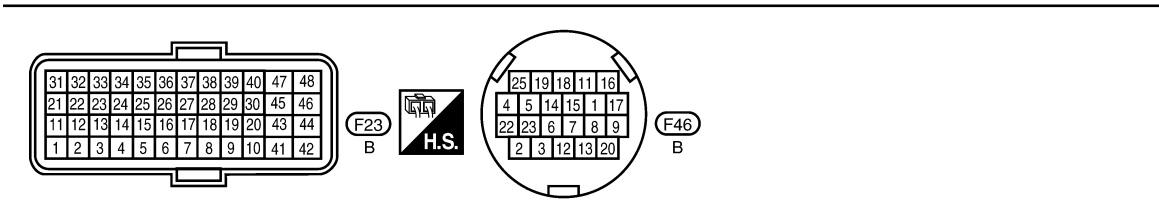
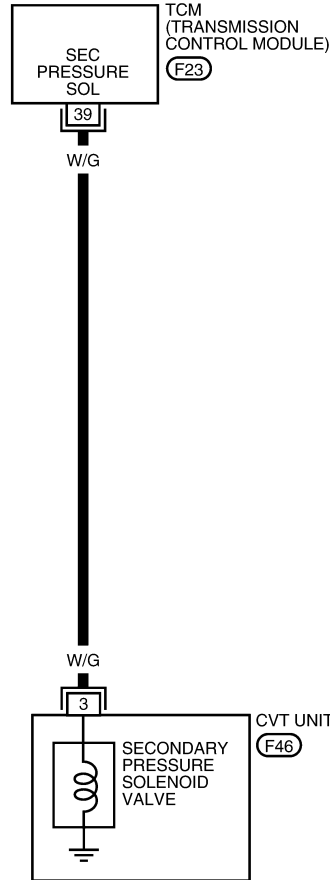

BCWA0743E

TCM TERMINALS AND REFERENCE VALUES
 Refer to [CVT-45, "TCM Input/Output Signal Reference Value"](#).

DTC P0778 PRESSURE CONTROL SOLENOID B ELECTRICAL (SEC PRES- SURE SOLENOID VALVE)

< SERVICE INFORMATION >

Diagnosis Procedure

INFOID:000000004407180

1. CHECK INPUT SIGNAL

④ With CONSULT-III

1. Start engine.
2. Select "MAIN SIGNALS" in "DATA MONITOR" mode for "TRANSMISSION" with CONSULT-III.
3. Read out the value of "ISOLT3".

Item name	Condition	Display value (Approx.)
ISOLT3	Secondary pressure low - Secondary pressure high	0.8 - 0.0 A

⊗ Without CONSULT-III

1. Start engine.
2. Check voltage between TCM connector terminal and ground.

Name	Connector	Terminal	Condition	Voltage (Approx.)
Pressure control solenoid valve B (Secondary pressure solenoid valve)	F23	39 - ground	Release your foot from the accelerator pedal.	5.0 - 7.0 V
			Press the accelerator pedal all the way down.	3.0 - 4.0 V

3. Turn ignition switch OFF.
4. Disconnect TCM connector.
5. Check if there is continuity between connector terminal and ground.

OK or NG

- OK >> GO TO 5.
NG >> GO TO 2.

2. CHECK PRESSURE CONTROL SOLENOID VALVE B (SECONDARY PRESSURE SOLENOID VALVE) CIRCUIT

1. Turn ignition switch OFF.
2. Disconnect TCM connector.
3. Check resistance between TCM connector terminal and ground.

Solenoid valve	Connector	Terminal	Resistance (Approx.)
Pressure control solenoid valve B (Secondary pressure solenoid valve)	F23	39 - Ground	3.0 - 9.0 Ω

OK or NG

- OK >> GO TO 5.
NG >> GO TO 3.

3. CHECK VALVE RESISTANCE

1. Turn ignition switch OFF.
2. Disconnect CVT unit harness connector.

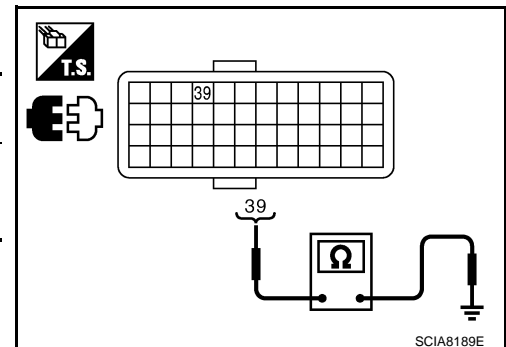

DTC P0778 PRESSURE CONTROL SOLENOID B ELECTRICAL (SEC PRESSURE SOLENOID VALVE)

< SERVICE INFORMATION >

3. Check resistance between CVT unit harness connector terminal and ground.

Solenoid valve	Connector	Terminal	Resistance (Approx.)
Pressure control solenoid valve B (Secondary pressure solenoid valve)	F46	3 - Ground	3.0 - 9.0 Ω

OK or NG

- OK >> GO TO 4.
- NG >> Repair or replace damaged parts.

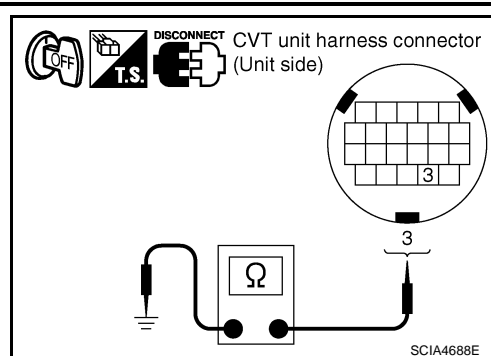

4. CHECK HARNESS BETWEEN TCM AND PRESSURE CONTROL SOLENOID VALVE B (SECONDARY PRESSURE SOLENOID VALVE)

1. Turn ignition switch OFF.
2. Disconnect TCM connector (A) and CVT unit harness connector (B).
3. Check continuity between TCM connector (A) terminal and CVT unit harness connector (B) terminal.

Item	Connector	Terminal	Continuity
TCM connector	F23	39	Yes
CVT unit harness connector	F46	3	

4. If OK, check harness for short to ground and short to power.
5. Reinstall any part removed.

OK or NG

- OK >> GO TO 5.
- NG >> Repair or replace damaged parts.

5. CHECK DTC

Perform [CVT-100, "DTC Confirmation Procedure"](#).

OK or NG

- OK >> **INSPECTION END**
- NG >> GO TO 6.

6. CHECK TCM

1. Check TCM input/output signals. Refer to [CVT-45, "TCM Input/Output Signal Reference Value"](#).
2. If NG, re-check TCM pin terminals for damage or loose connection with harness connector.

OK or NG

- OK >> **INSPECTION END**
- NG >> 1. Repair or replace damaged parts.
2. Replace the transaxle assembly. Refer to [CVT-190, "Removal and Installation \(MR20DE\)"](#).

Component Inspection

INFOID:000000004407181

PRESSURE CONTROL SOLENOID VALVE B (SECONDARY PRESSURE SOLENOID VALVE)

1. Turn ignition switch OFF.
2. Disconnect CVT unit harness connector.

DTC P0778 PRESSURE CONTROL SOLENOID B ELECTRICAL (SEC PRESSURE SOLENOID VALVE)

< SERVICE INFORMATION >

3. Check resistance between CVT unit harness connector terminal and ground.

Solenoid Valve	Connector	Terminal	Resistance (Approx.)
Pressure control solenoid valve B (Secondary pressure solenoid valve)	F46	3 - Ground	3.0 - 9.0 Ω

4. If NG, replace the transaxle assembly. Refer to [CVT-190](#), "[Removal and Installation \(MR20DE\)](#)".

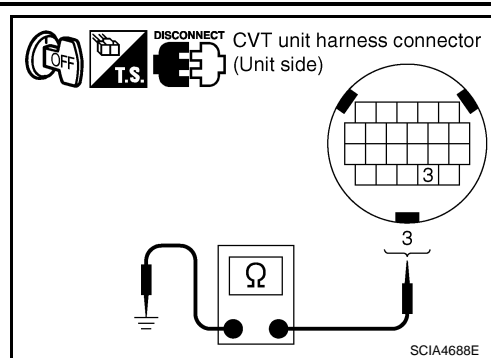

DTC P0826 MANUAL MODE SWITCH CIRCUIT

< SERVICE INFORMATION >

DTC P0826 MANUAL MODE SWITCH CIRCUIT

Description

INFOID:000000004407182

TCM sends the switch signals to combination meter via CAN communication line. Then manual mode switch position is indicated on the CVT position indicator. For inspection, refer to [CVT-107, "Diagnosis Procedure"](#)

CONSULT-III Reference Value in Data Monitor Mode

INFOID:000000004407183

Item name	Condition	Display value
MMODE	When manual mode	ON
	Other than the above	OFF
NON MMODE	When manual mode	OFF
	Other than the above	ON
STRDWN SW	Steering shift switch: - side	ON
	Other than the above	OFF
STRUP	Steering shift switch: + side	ON
	Other than the above	OFF

On Board Diagnosis Logic

INFOID:000000004407184

- This is not an OBD-II self-diagnostic item.
- Diagnostic trouble code "P0826 MANUAL MODE SWITCH" with CONSULT-III is detected when TCM monitors Manual mode, Non manual mode, Up or Down switch signal, and then detects irregular with impossible input pattern for 1 second or more.

Possible Cause

INFOID:000000004407185

- Harness or connectors
(These switches circuit is open or shorted.)
(TCM, and combination meter circuit are open or shorted.)
(CAN communication line is open or shorted.)
- Manual mode select switch.
- Manual mode position select switch.

DTC Confirmation Procedure

INFOID:000000004407186

CAUTION:

Always drive vehicle at a safe speed.

NOTE:

If "DTC Confirmation Procedure" has been previously conducted, always turn ignition switch OFF and wait at least 10 seconds before conducting the next test.

After the repair, perform the following procedure to confirm the malfunction is eliminated.

Ⓟ WITH CONSULT-III

1. Turn ignition switch ON. (Do not start engine.)
2. Select "DATA MONITOR" mode for "TRANSMISSION" with CONSULT-III.
3. Start engine.
4. Push manual mode switch "".
5. Drive vehicle for at least 2 consecutive seconds.
6. If DTC is detected, go to [CVT-107, "Diagnosis Procedure"](#).





DTC P0826 MANUAL MODE SWITCH CIRCUIT

< SERVICE INFORMATION >

Wiring Diagram - CVT - MMSW

INFOID:000000004407187

CVT-MMSW-01

-  : DETECTABLE LINE FOR DTC
-  : NON-DETECTABLE LINE FOR DTC
-  : DATA LINE
-  : WITH QR25DE

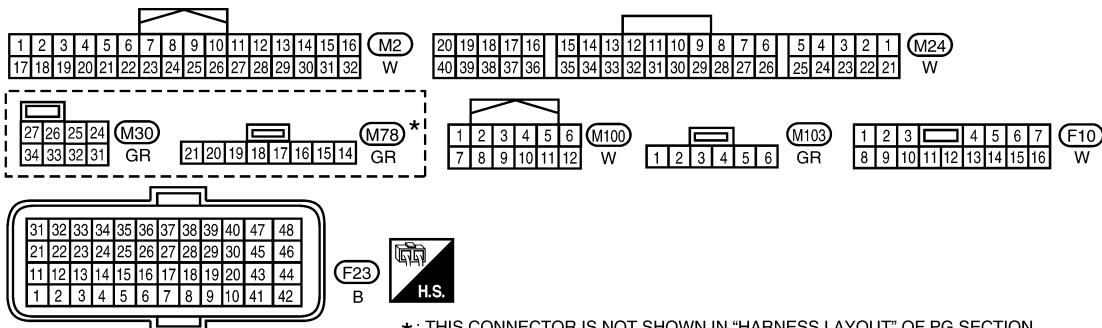
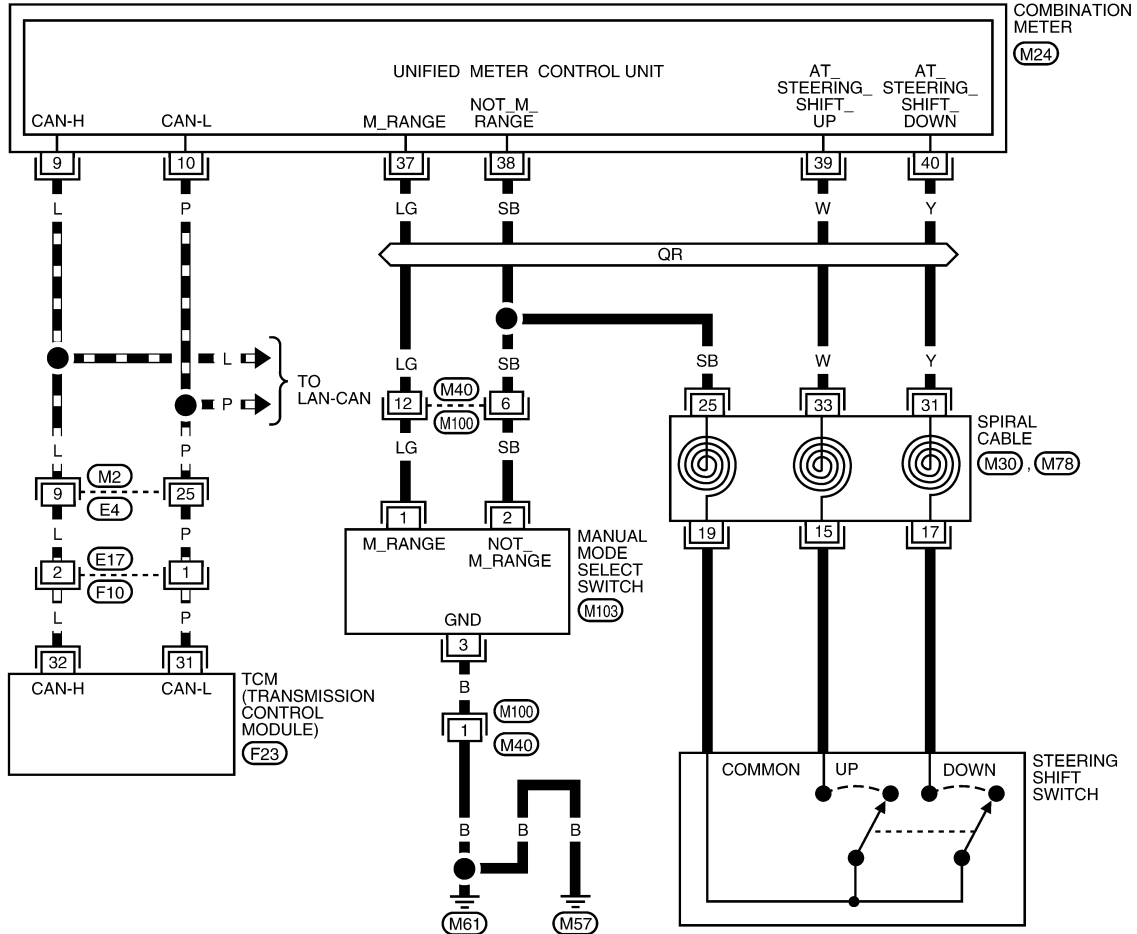

* : THIS CONNECTOR IS NOT SHOWN IN "HARNESS LAYOUT" OF PG SECTION.

AADWA0037GI

TCM TERMINALS AND REFERENCE VALUES

Refer to [CVT-45, "TCM Input/Output Signal Reference Value"](#).

DTC P0826 MANUAL MODE SWITCH CIRCUIT

< SERVICE INFORMATION >

Diagnosis Procedure

INFOID:000000004407188

1. CHECK CAN COMMUNICATION LINE

Perform the self-diagnosis check. Refer to [CVT-47, "CONSULT-III Function \(TRANSMISSION\)"](#).

Is any malfunction of the "U1000 CAN COMM CIRCUIT" indicated?

YES >> Check CAN communication line. Refer to [CVT-55](#).

NO >> GO TO 2.

2. CHECK MANUAL MODE SWITCH SIGNALS

With CONSULT-III

1. Turn ignition switch ON. (Do not start engine.)
2. Select "ECU INPUT SIGNALS" in "DATA MONITOR" mode for "TRANSMISSION" with CONSULT-III.
3. Read out ON/OFF switching action of the "STRDWNSW", "STRUPSW", "NONMMODE", "MMODE".

Item name	Condition	Display value
MMODE	When manual mode	ON
	Other than the above	OFF
NONMMODE	When manual mode	OFF
	Other than the above	ON
STRDWNSW	Steering shift switch: - side	ON
	Other than the above	OFF
STRUPSW	Steering shift switch: + side	ON
	Other than the above	OFF

Without CONSULT-III

Drive vehicle in the manual mode, and confirm that the actual gear position and the meter's indication of the position mutually coincide when the selector lever is shifted to the "+ (up)" or "- (down)" side (1st ⇔ 6th gear).

OK or NG

OK >> GO TO 7.

NG >> GO TO 3.

3. CHECK STEERING SHIFT SWITCH AND MANUAL MODE SWITCH

Check steering shift switch and manual mode switch. Refer to [CVT-109, "Component Inspection"](#).

OK or NG

OK >> GO TO 4.

NG >> Repair or replace damaged parts.

4. CHECK BETWEEN STEERING SHIFT SWITCH AND COMBINATION METER

1. Turn ignition switch OFF.
2. Disconnect spiral cable harness connector and combination meter harness connector.
3. Check continuity between spiral cable harness connector terminals and combination meter harness connector terminals.

Item	Connector	Terminal	Continuity
Spiral cable harness connector	M30	25	Yes
Combination meter harness connector	M24	38	
Spiral cable harness connector	M30	31	Yes
Combination meter harness connector	M24	40	
Spiral cable harness connector	M30	33	Yes
Combination meter harness connector	M24	39	

4. If OK, check harness for short to ground and short to power.

DTC P0826 MANUAL MODE SWITCH CIRCUIT

< SERVICE INFORMATION >

OK or NG

- OK >> GO TO 5.
NG >> Repair or replace damaged harness.

5.CHECK BETWEEN MANUAL MODE SWITCH AND COMBINATION METER

1. Disconnect manual mode select switch harness connector.
2. Check continuity between manual mode select switch harness connector terminals and combination meter harness connector terminals.

Item	Connector	Terminal	Continuity
Manual mode select switch harness connector	M103	1	Yes
Combination meter harness connector	M24	37	
Manual mode select switch harness connector	M103	2	Yes
Combination meter harness connector	M24	38	

3. Check continuity between manual mode select switch harness connector and ground.

Item	Connector	Terminal	Continuity
Manual mode select switch harness connector	M103	3 - ground	Yes

4. If OK, check harness for short to ground and short to power.

OK or NG

- OK >> GO TO 6.
NG >> Repair or replace damaged harness.

6.CHECK SPIRAL CABLE

1. Disconnect spiral cable connector.
2. Check continuity between spiral cable connector terminals.

Item	Connector	Terminal	Continuity
Spiral cable connector	M78	15	Yes
	M30	33	
	M17	17	Yes
	M31	31	
	M19	19	Yes
	M25	25	

OK or NG

- OK >> GO TO 7.
NG >> Replace spiral cable. Refer to [SRS-33](#).

7.CHECK COMBINATION METER

Check combination meter. Refer to [DI-13, "Self-Diagnosis Mode of Combination Meter"](#).

OK or NG?

- YES >> GO TO 8.
NO >> Replace combination meter. Refer to [DI-22, "Removal and Installation"](#).

8.CHECK DTC

Perform "DTC Confirmation Procedure". Refer to [CVT-105, "DTC Confirmation Procedure"](#).

OK or NG

- OK >> **INSPECTION END**
NG >> GO TO 9.

9.CHECK TCM

1. Check TCM input/output signals. Refer to [CVT-45, "TCM Input/Output Signal Reference Value"](#).

DTC P0826 MANUAL MODE SWITCH CIRCUIT

< SERVICE INFORMATION >

2. If NG, re-check TCM pin terminals for damage or loose connection with harness connector.

OK or NG

OK >> **INSPECTION END**

NG >> Repair or replace damaged parts.

Component Inspection

INFOID:000000004407189

STEERING SHIFT SWITCH

Check continuity between spiral cable connector terminals.

Terminals	Operation	Continuity
15 - 19	While pushing steering shift switch (+ side)	Yes
	Other condition	No
17 - 19	While pushing steering shift switch (- side)	Yes
	Other condition	No

MANUAL MODE SWITCH

Check continuity between manual mode select switch harness connector terminals.

Terminals	Operation	Continuity
1 - 3	When manual mode	No
	Other condition	Yes
2 - 3	When not in manual mode	Yes
	Other condition	No

A

B

CVT

D

E

F

G

H

I

J

K

L

M

N

O

P

DTC P0840 TRANSMISSION FLUID PRESSURE SENSOR A CIRCUIT (SEC PRESSURE SENSOR)

< SERVICE INFORMATION >

DTC P0840 TRANSMISSION FLUID PRESSURE SENSOR A CIRCUIT (SEC PRESSURE SENSOR)

Description

INFOID:000000004407190

- The transmission fluid pressure sensor A (secondary pressure sensor) detects secondary pressure of CVT and sends TCM the signal.

CONSULT-III Reference Value

INFOID:000000004407191

Remarks: Specification data are reference values.

Item name	Condition	Display value (Approx.)
SEC HYDR SEN	"N" position idle	1.0 V
SEC PRESS		1.3 MPa

On Board Diagnosis Logic

INFOID:000000004407192

- This is an OBD-II self-diagnostic item.
- Diagnostic trouble code "P0840 TR PRS SENS/A CIRC" with CONSULT-III is detected when TCM detects an improper voltage drop when it receives the sensor signal.

Possible Cause

INFOID:000000004407193

- Transmission fluid pressure sensor A (Secondary pressure sensor)
- Harness or connectors
(Switch circuit is open or shorted.)

DTC Confirmation Procedure

INFOID:000000004407194

NOTE:

If "DTC Confirmation Procedure" has been previously performed, always turn ignition switch OFF and wait at least 10 seconds before performing the next test.

After the repair, perform the following procedure to confirm the malfunction is eliminated.

Ⓟ WITH CONSULT-III

1. Turn ignition switch ON and select "DATA MONITOR" mode for "TRANSMISSION" with CONSULT-III.
2. Make sure that output voltage of line temperature sensor is within the range below.
ATF TEMP SEN: 1.0 - 2.0 V
If out of range, drive the vehicle to decrease the voltage (warm up the fluid) or stop engine to increase the voltage (cool down the fluid)
3. Start engine and wait for at least 5 consecutive seconds.
4. If DTC is detected, go to [CVT-112. "Diagnosis Procedure"](#).

Ⓢ WITH GST

Follow the procedure "WITH CONSULT-III".

DTC P0840 TRANSMISSION FLUID PRESSURE SENSOR A CIRCUIT (SEC PRESSURE SENSOR)

< SERVICE INFORMATION >

Wiring Diagram - CVT - SECPS

INFOID:000000004407195

CVT-SECPS-01

: DETECTABLE LINE FOR DTC
 : NON-DETECTABLE LINE FOR DTC

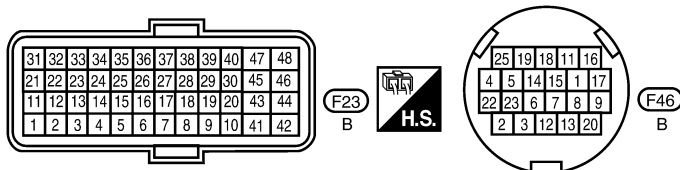
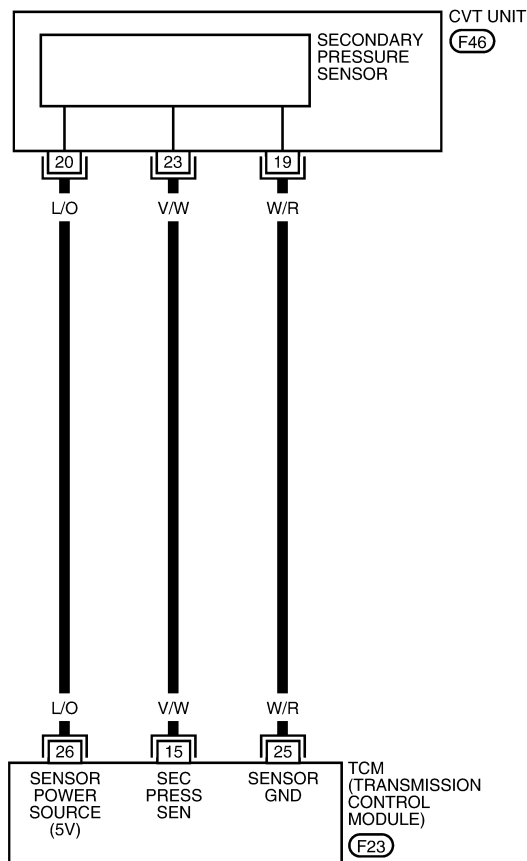

BCWA0744E

TCM TERMINALS AND REFERENCE VALUES

Refer to [CVT-45. "TCM Input/Output Signal Reference Value"](#).

DTC P0840 TRANSMISSION FLUID PRESSURE SENSOR A CIRCUIT (SEC PRESSURE SENSOR)

< SERVICE INFORMATION >

Diagnosis Procedure

INFOID:000000004407196

1. CHECK INPUT SIGNAL

④ With CONSULT-III

1. Start engine.
2. Select "ECU INPUT SIGNALS" in "DATA MONITOR" mode for "TRANSMISSION" with CONSULT-III.
3. Start vehicle and read out the value of "SEC HYDR SEN".

Item name	Condition	Display value (Approx.)
SEC HYDR SEN	"N" position idle	1.0 V

⊗ Without CONSULT-III

1. Start engine.
2. Check voltage between TCM connector terminal and ground.

Name	Connector	Terminal	Condition	Voltage (Approx.)
Transmission fluid pressure sensor A (Secondary pressure sensor)	F23	15 - Ground	"N" position idle	1.0 V

OK or NG

- OK >> GO TO 5.
 NG >> GO TO 2.

2. CHECK HARNESS BETWEEN TCM AND TRANSMISSION FLUID PRESSURE SENSOR A (SECONDARY PRESSURE SENSOR)

1. Turn ignition switch OFF.
2. Disconnect TCM connector (A) and CVT unit harness connector (B).
3. Check continuity between TCM connector (A) terminal and CVT unit harness connector (B) terminal.

Item	Connector	Terminal	Continuity
TCM connector	F23	15	YES
CVT unit harness connector	F46	23	

4. If OK, check harness for short to ground and short to power.
5. Reinstall any part removed.

OK or NG

- OK >> GO TO 3.
 NG >> Repair open circuit or short to ground and short to power harness or connectors.

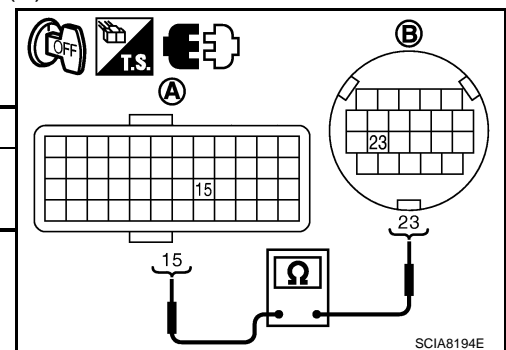

3. CHECK HARNESS BETWEEN TCM AND CVT UNIT HARNESS CONNECTOR (SENSOR POWER AND SENSOR GROUND)

1. Turn ignition switch OFF.
2. Disconnect TCM connector (A) and CVT unit harness connector (B).

DTC P0840 TRANSMISSION FLUID PRESSURE SENSOR A CIRCUIT (SEC PRESSURE SENSOR)

< SERVICE INFORMATION >

3. Check continuity between TCM connector (A) terminals and CVT unit harness connector (B) terminals.

Item	Connector	Terminal	Continuity
TCM	F23	26	Yes
CVT unit harness connector	F46	20	
TCM	F23	25	Yes
CVT unit harness connector	F46	19	

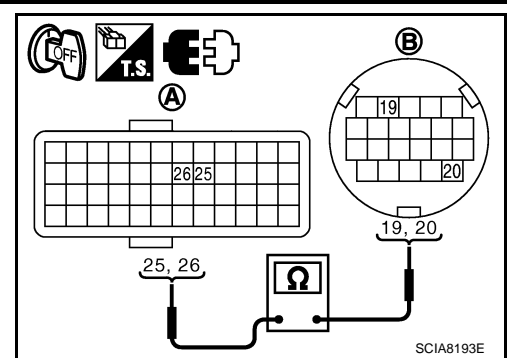

4. If OK, check harness for short to ground and short to power.
5. Reinstall any part removed.

OK or NG

- OK >> GO TO 4.
- NG >> Repair open circuit or short to ground or short to power in harness or connectors.

4.CHECK SENSOR POWER AND SENSOR GROUND

1. Turn ignition switch ON.
2. Disconnect CVT unit harness connector.
3. Check voltage between CVT unit harness connector terminal.

Item	Connector	Terminal	Data (Approx.)
CVT unit harness connector (vehicle side)	F46	19 - 20	5.0 V

OK or NG

- OK >> Replace the transaxle assembly. Refer to [CVT-190](#).
- NG >> Replace TCM. Refer to [CVT-162, "Removal and Installation"](#).

5.CHECK DTC

Perform [CVT-110, "DTC Confirmation Procedure"](#).

OK or NG

- OK >> **INSPECTION END**
- NG >> GO TO 6.

6.CHECK TCM

1. Check TCM input/output signals. Refer to [CVT-45, "TCM Input/Output Signal Reference Value"](#).
2. If NG, re-check TCM pin terminals for damage or loose connection with harness connector.

OK or NG

- OK >> Replace the transaxle assembly. Refer to [CVT-190, "Removal and Installation \(MR20DE\)"](#).
- NG >> Repair or replace damaged parts.

DTC P0841 PRESSURE SENSOR FUNCTION

< SERVICE INFORMATION >

DTC P0841 PRESSURE SENSOR FUNCTION

Description

INFOID:000000004407197

Using the engine load (throttle position), the primary pulley revolution speed, and the secondary pulley revolution speed as input signal, TCM changes the operating pressure of the primary pulley and the secondary pulley and changes the groove width of the pulley to control the gear ratio.

CONSULT-III Reference Value

INFOID:000000004407198

Remarks: Specification data are reference values.

Item name	Condition	Display value (Approx.)
SEC HYDR SEN	"N" position idle	1.0 V

On Board Diagnosis Logic

INFOID:000000004407199

- This is not an OBD-II self-diagnostic item.
- Diagnostic trouble code "P0841 PRESS SEN/FNCTN" with CONSULT-III is detected when correlation between the values of the secondary pressure sensor and the primary pressure sensor is out of specification.

Possible Cause

INFOID:000000004407200

- Transmission fluid pressure sensor A (Secondary pressure sensor)
- Harness or connectors
(Sensor circuit is open or shorted.)

DTC Confirmation Procedure

INFOID:000000004407201

CAUTION:

Always drive vehicle at a safe speed.

NOTE:

If "DTC Confirmation Procedure" has been previously performed, always turn ignition switch OFF and wait at least 10 seconds before performing the next test.

After the repair, perform the following procedure to confirm the malfunction is eliminated.

Ⓟ WITH CONSULT-III

1. Turn ignition switch ON and select "DATA MONITOR" mode for "TRANSMISSION" with CONSULT-III.
2. Start engine and maintain the following conditions for at least 12 consecutive seconds.
VEHICLE SPEED: 40 km/h (25 MPH) More than
RANGE: "D" position
3. If DTC is detected, go to [CVT-114. "Diagnosis Procedure"](#).

Diagnosis Procedure

INFOID:000000004407202

1. CHECK CAN COMMUNICATION LINE

Perform the self-diagnosis. Refer to [CVT-47. "CONSULT-III Function \(TRANSMISSION\)"](#).

Is any malfunction of the "U1000 CAN COMM CIRCUIT" indicated?

YES >> Check CAN communication line. Refer to [CVT-55](#).

NO >> GO TO 2.

2. CHECK INPUT SIGNALS

Ⓟ With CONSULT-III

1. Start engine.
2. Select "ECU INPUT SIGNALS" in "DATA MONITOR" mode for "TRANSMISSION" with CONSULT-III.
3. Start vehicle and read out the value of "SEC HYDR SEN".

Item name	Condition	Display value (Approx.)
SEC HYDR SEN	"N" position idle	1.0 V

DTC P0841 PRESSURE SENSOR FUNCTION

< SERVICE INFORMATION >

⊗ Without CONSULT-III

1. Start engine.
2. Check voltage between TCM connector terminals and ground.

Name	Connector	Terminal	Condition	Voltage (Approx.)
Transmission fluid pressure sensor A (Secondary pressure sensor)	F23	15 - Ground	"N" position idle	1.0 V

OK or NG

- OK >> GO TO 6.
NG >> GO TO 3.

3.CHECK LINE PRESSURE

Perform line pressure test. Refer to [CVT-36, "Inspections before Trouble Diagnosis"](#).

OK or NG

- OK >> GO TO 4.
NG >> Repair or replace damaged parts. Refer to [CVT-36, "Inspections before Trouble Diagnosis"](#).

4.CHECK TRANSMISSION FLUID PRESSURE SENSOR A (SECONDARY PRESSURE SENSOR) SYSTEM

Check transmission fluid pressure sensor A (secondary pressure sensor) system. Refer to [CVT-110](#).

OK or NG

- OK >> GO TO 5.
NG >> Repair or replace damaged parts.

5.DETECT MALFUNCTIONING ITEM

Check the following:

- Pressure control solenoid valve A (Line pressure solenoid valve). Refer to [CVT-94, "Component Inspection"](#).
- Pressure control solenoid valve B (Secondary pressure solenoid valve). Refer to [CVT-103, "Component Inspection"](#).
- Step motor. Refer to [CVT-138, "Component Inspection"](#).

OK or NG6

- OK >> GO TO 6.
NG >> Repair or replace damaged parts.

6.CHECK DTC

Perform [CVT-114, "DTC Confirmation Procedure"](#).

OK or NG

- OK >> **INSPECTION END**
NG >> Replace TCM or transaxle assembly. Refer to [CVT-190, "Removal and Installation \(MR20DE\)"](#).

A
B
CVT
D
E
F
G
H
I
J
K
L
M
N
O
P

DTC P0868 SECONDARY PRESSURE DOWN

< SERVICE INFORMATION >

DTC P0868 SECONDARY PRESSURE DOWN

Description

INFOID:0000000044072.10

- The pressure control solenoid valve B (secondary pressure solenoid valve) regulates the secondary pressure to suit the driving condition in response to a signal sent from the TCM.

CONSULT-III Reference Value

INFOID:0000000044072.11

Remarks: Specification data are reference values.

Item name	Condition	Display value (Approx.)
SEC PRESS	"N" position idle	0.5 MPa

On Board Diagnosis Logic

INFOID:0000000044072.12

- This is not an OBD-II self-diagnostic item.
- Diagnostic trouble code "P0868 SEC/PRESS DOWN" with CONSULT-III is detected when secondary fluid pressure is too low compared with the commanded value while driving.

Possible Cause

INFOID:0000000044072.13

- Harness or connectors
(Solenoid circuit is open or shorted.)
- Pressure control solenoid valve B (Secondary pressure solenoid valve) system
- Transmission fluid pressure sensor A (Secondary pressure sensor)
- Line pressure control system

DTC Confirmation Procedure

INFOID:0000000044072.14

CAUTION:

Always drive vehicle at a safe speed.

NOTE:

If "DTC Confirmation Procedure" has been previously performed, always turn ignition switch OFF and wait at least 10 seconds before performing the next test.

After the repair, perform the following procedure to confirm the malfunction is eliminated.

④ WITH CONSULT-III

1. Turn ignition switch ON and select "DATA MONITOR" mode for "TRANSMISSION" with CONSULT-III.
2. Make sure that output voltage of CVT fluid temperature sensor is within the range below.
ATF TEMP SEN: 1.0 - 2.0 V
If out of range, drive the vehicle to decrease the voltage (warm up the fluid) or stop engine to increase the voltage (cool down the fluid)
3. Start engine and maintain the following conditions for at least 10 consecutive seconds.
VEHICLE SPEED (accelerate slowly): 0 → 50 km/h (31 MPH)
ACC PEDAL OPEN: 0.5/8 - 1.0/8
RANGE: "D" position
4. If DTC is detected, go to [CVT-116, "Diagnosis Procedure"](#).

Diagnosis Procedure

INFOID:0000000044072.15

1. CHECK INPUT SIGNAL

④ With CONSULT-III

1. Start engine.
2. Select "MAIN SIGNALS" in "DATA MONITOR" mode for "TRANSMISSION" with CONSULT-III.
3. Start vehicle and read out the value of "SEC PRESS".

Item name	Condition	Display value (Approx.)
SEC PRESS	"N" position idle	0.5 MPa

OK or NG

OK >> GO TO 5.

DTC P0868 SECONDARY PRESSURE DOWN

< SERVICE INFORMATION >

NG >> GO TO 2.

2.CHECK LINE PRESSURE

Perform line pressure test. Refer to [CVT-36, "Inspections before Trouble Diagnosis"](#).

OK or NG

OK >> GO TO 3.

NG >> Repair or replace damaged parts. Refer to [CVT-36, "Inspections before Trouble Diagnosis"](#).

3.DETECT MALFUNCTIONING ITEM

Check the following:

- Pressure control solenoid valve B (Secondary pressure solenoid valve). Refer to [CVT-103, "Component Inspection"](#).
- Pressure control solenoid valve A (Line pressure solenoid valve). Refer to [CVT-94, "Component Inspection"](#).

OK or NG

OK >> GO TO 4.

NG >> Repair or replace damaged parts.

4.CHECK TRANSMISSION FLUID PRESSURE SENSOR A (SECONDARY PRESSURE SENSOR) SYSTEM

Check transmission fluid pressure sensor A (secondary pressure sensor) system. Refer to [CVT-110](#).

OK or NG

OK >> GO TO 5.

NG >> Repair or replace damaged parts.

5.DETECT MALFUNCTIONING ITEM

Check the following:

- Power supply and ground circuit for TCM. Refer to [CVT-119, "Wiring Diagram - CVT - POWER"](#).
- The TCM pin terminals for damage or loose connection with harness connector.

OK or NG

OK >> GO TO 6.

NG >> Repair or replace damaged parts.

6.CHECK DTC

Perform [CVT-116, "DTC Confirmation Procedure"](#).

OK or NG

OK >> **INSPECTION END**

NG >> Replace the transaxle assembly. Refer to [CVT-190, "Removal and Installation \(MR20DE\)"](#).

A

B

CVT

D

E

F

G

H

I

J

K

L

M

N

O

P

DTC P1701 TRANSMISSION CONTROL MODULE (POWER SUPPLY)

< SERVICE INFORMATION >

DTC P1701 TRANSMISSION CONTROL MODULE (POWER SUPPLY)

Description

INFOID:000000004407216

When the power supply to the TCM is cut OFF, for example because the battery is removed, and the self-diagnosis memory function stops, malfunction is detected.

NOTE:

Since “P1701 TCM-POWER SUPPLY” will be indicated when replacing TCM, perform diagnosis after erasing “SELF-DIAG RESULTS”

On Board Diagnosis Logic

INFOID:000000004407217

- This is not an OBD-II self-diagnostic item.
- Diagnostic trouble code “P1701 TCM-POWER SUPPLY” with CONSULT-III is detected when TCM does not receive the voltage signal from the battery power supply.
- This is not a malfunction message. (Whenever shutting OFF a power supply to the TCM, this message appears on the screen.)

Possible Cause

INFOID:000000004407218

Harness or connectors

(Battery or ignition switch and TCM circuit is open or shorted.)

DTC Confirmation Procedure

INFOID:000000004407219

NOTE:

If “DTC Confirmation Procedure” has been previously conducted, always turn ignition switch OFF and wait at least 10 seconds before conducting the next test.

After the repair, perform the following procedure to confirm the malfunction is eliminated.

Ⓜ WITH CONSULT-III

1. Turn ignition switch ON. (Do not start engine.)
2. Select “DATA MONITOR” mode for “TRANSMISSION” with CONSULT-III.
3. Wait for at least 2 consecutive seconds.
4. If DTC is detected, go to [CVT-120. "Diagnosis Procedure"](#).

DTC P1701 TRANSMISSION CONTROL MODULE (POWER SUPPLY)

< SERVICE INFORMATION >

Wiring Diagram - CVT - POWER

INFOID:000000004407220

CVT-POWER-01

: DETECTABLE LINE FOR DTC
 : NON-DETECTABLE LINE FOR DTC

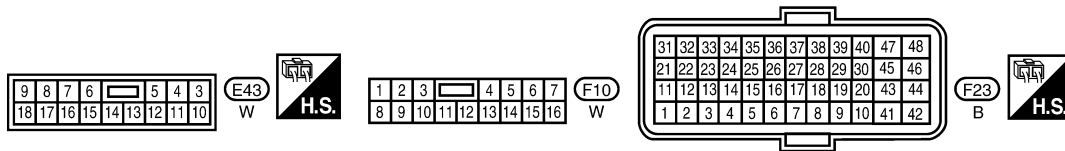
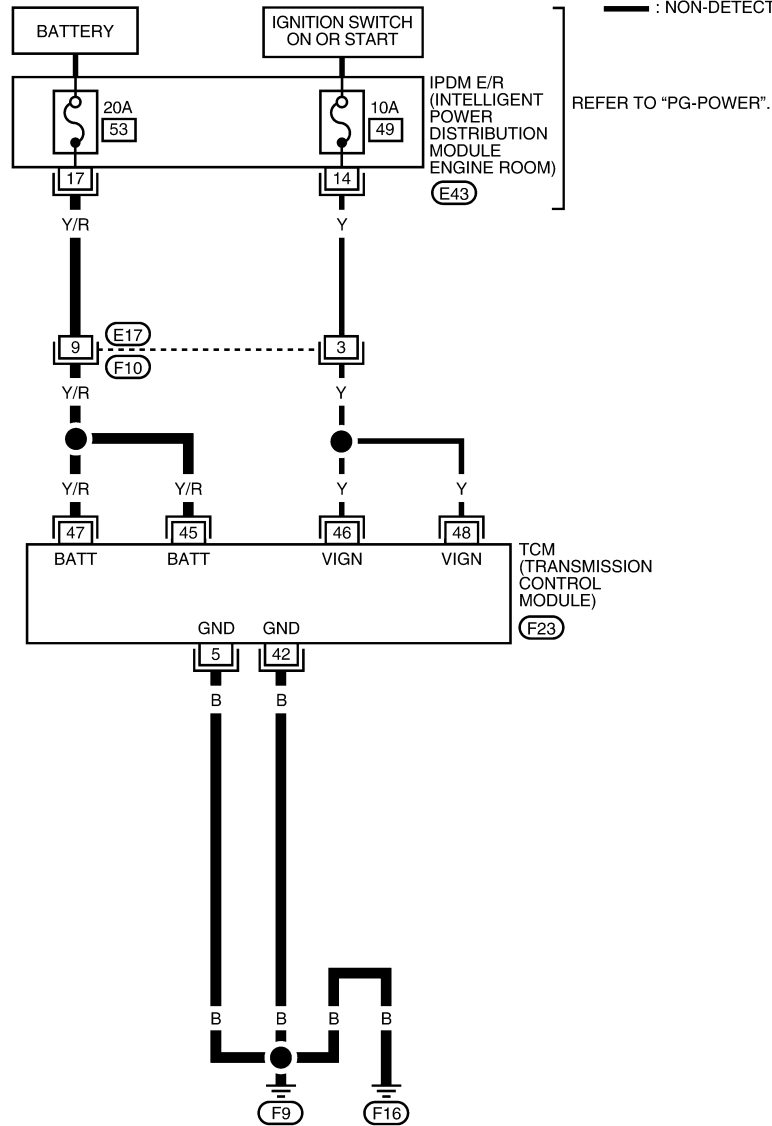

BCWA0746E

TCM TERMINALS AND REFERENCE VALUES

Refer to [CVT-45. "TCM Input/Output Signal Reference Value"](#).

DTC P1701 TRANSMISSION CONTROL MODULE (POWER SUPPLY)

< SERVICE INFORMATION >

Diagnosis Procedure

INFOID:000000004407221

1. CHECK DTC

1. Turn ignition switch ON.
2. Select "SELF-DIAG RESULTS" mode for "TRANSMISSION" with CONSULT-III.
3. Erase self-diagnostic results. Refer to [CVT-25. "OBD-II Diagnostic Trouble Code \(DTC\)"](#).
4. Turn ignition switch OFF, and wait for 5 seconds or more.
5. Start engine.
6. Confirm self-diagnostic results again. Refer to [CVT-47. "CONSULT-III Function \(TRANSMISSION\)"](#).

Is the "P1701 TCM-POWER SUPPLY" displayed?

YES >> GO TO 2.

NO >> **INSPECTION END**

2. CHECK TCM POWER SOURCE, STEP 1

1. Turn ignition switch OFF.
2. Check voltage between TCM connector terminal and ground.

Name	Connector	Terminal	Condition	Voltage (Approx.)
Power supply (memory back-up)	F23	45 - Ground	Always	Battery voltage
		47 - Ground		





OK or NG

OK >> GO TO 3.

NG >> GO TO 4.

3. CHECK TCM POWER SOURCE, STEP 2

1. Turn ignition switch ON.
2. Check voltage between TCM connector terminals and ground.

Name	Connector	Terminal	Condition	Voltage (Approx.)	
Power supply	F23	46 - Ground		Battery voltage	
				0 V	
Power supply		48 - Ground		Battery voltage	
				0 V	
Power supply (memory back-up)		45 - Ground	Always		Battery voltage

OK or NG

OK >> GO TO 5.

NG >> GO TO 4.

4. DETECT MALFUNCTIONING ITEM

Check the following.

- Harness for short or open between battery and TCM connector terminal 45, 47
- Harness for short or open between ignition switch and TCM connector terminal 46, 48

DTC P1701 TRANSMISSION CONTROL MODULE (POWER SUPPLY)

< SERVICE INFORMATION >

- 10 A fuse (No.49, located in the IPDM E/R)
- 20 A fuse (No.53, located in the IPDM E/R)
- Ignition switch. Refer to [PG-3](#).

OK or NG

- OK >> GO TO 5.
- NG >> Repair or replace damaged parts.

5.CHECK TCM GROUND CIRCUIT

1. Turn ignition switch OFF.
2. Disconnect TCM connector.
3. Check continuity between TCM connector terminals and ground.

Name	Connector	Terminal	Continuity
Ground	F23	5 - Ground	Yes
		42 - Ground	

OK or NG

- OK >> GO TO 6.
- NG >> Repair open circuit or short to ground or short to power in harness or connectors.

6.CHECK DTC

Perform [CVT-118, "DTC Confirmation Procedure"](#).

OK or NG

- OK >> **INSPECTION END**
- NG >> GO TO 7.

7.CHECK TCM

1. Check TCM input/output signals. Refer to [CVT-45, "TCM Input/Output Signal Reference Value"](#).
2. If NG, re-check TCM pin terminals for damage or loose connection with harness connector.

OK or NG

- OK >> **INSPECTION END**
- NG >> Repair or replace damaged parts.

A
B
CVT
D
E
F
G
H
I
J
K
L
M
N
O
P

DTC P1705 THROTTLE POSITION SENSOR

< SERVICE INFORMATION >

DTC P1705 THROTTLE POSITION SENSOR

Description

INFOID:000000004407222

Electric throttle control actuator consists of throttle control motor, accelerator pedal position sensor, throttle position sensor etc. The actuator sends a signal to the ECM, and ECM sends the signal to TCM with CAN communication.

CONSULT-III Reference Value

INFOID:000000004407223

Remarks: Specification data are reference values.

Item name	Condition	Display value (Approx.)
ACC PEDAL OPEN	Released accelerator pedal - Fully depressed accelerator pedal	0.0/8 - 8.0/8

On Board Diagnosis Logic

INFOID:000000004407224

- This is not an OBD-II self-diagnostic item.
- Diagnostic trouble code "P1705 TP SEN/CIRC A/T" with CONSULT-III is detected when TCM does not receive the proper accelerator pedal position signals (input by CAN communication) from ECM.

Possible Cause

INFOID:000000004407225

- ECM
- Harness or connectors
(CAN communication line is open or shorted.)

DTC Confirmation Procedure

INFOID:000000004407226

NOTE:

If "DTC Confirmation Procedure" has been previously performed, always turn ignition switch OFF and wait at least 10 seconds before performing the next test.

After the repair, perform the following procedure to confirm the malfunction is eliminated.

Ⓟ WITH CONSULT-III

1. Turn ignition switch ON.
2. Select "DATA MONITOR" mode for "TRANSMISSION" with CONSULT-III.
3. Depress accelerator pedal fully and release it, then wait for 5 seconds.
4. If DTC is detected, go to [CVT-122, "Diagnosis Procedure"](#).

Diagnosis Procedure

INFOID:000000004407227

1.CHECK CAN COMMUNICATION LINE

Perform the self-diagnosis check. Refer to [CVT-47, "CONSULT-III Function \(TRANSMISSION\)"](#).

Is any malfunction of the "U1000 CAN COMM CIRCUIT" indicated?

YES >> Check the CAN communication line. Refer to [CVT-55](#).

NO >> GO TO 2.

2.CHECK INPUT SIGNAL

Ⓟ With CONSULT-III

1. Turn ignition switch ON.
2. Select "ECU INPUT SIGNALS" in "DATA MONITOR" mode for "TRANSMISSION" with CONSULT-III.
3. Read out the value of "ACC PEDAL OPEN".

Item name	Condition	Display value (Approx.)
ACC PEDAL OPEN	Release accelerator pedal.	0.0/8
	↓ Fully depressed accelerator pedal	↓ 8.0/8

OK or NG

DTC P1705 THROTTLE POSITION SENSOR

< SERVICE INFORMATION >

- OK >> GO TO 4.
- NG >> GO TO 3.

3.CHECK DTC WITH ECM

With CONSULT-III

1. Turn ignition switch ON.
2. Select "SELF-DIAG RESULTS" mode for "ENGINE" with CONSULT-III. Refer to [EC-123, "CONSULT-III Function \(ENGINE\)"](#).

OK or NG

- OK >> GO TO 4.
- NG >> Check the DTC Detected Item. Go to [EC-123, "CONSULT-III Function \(ENGINE\)"](#).

4.CHECK DTC

Perform [CVT-122, "DTC Confirmation Procedure"](#).

OK or NG

- OK >> **INSPECTION END**
- NG >> Repair or replace damaged parts.

A

B

CVT

D

E

F

G

H

I

J

K

L

M

N

O

P

DTC P1722 ESTM VEHICLE SPEED SIGNAL

< SERVICE INFORMATION >

DTC P1722 ESTM VEHICLE SPEED SIGNAL

Description

INFOID:000000004407228

The vehicle speed signal is transmitted from ABS actuator and electric unit (control unit) to TCM by CAN communication line.

CONSULT-III Reference Value

INFOID:000000004407229

Remarks: Specification data are reference values.

Item name	Condition	Display value
ESTM VSP SIG	During driving	Approximately matches the speedometer reading.
VEHICLE SPEED		

On Board Diagnosis Logic

INFOID:000000004407230

- This is not an OBD-II self-diagnostic item.
- Diagnostic trouble code "P1722 ESTM VEH SPD SIG" with CONSULT-III is detected when TCM does not receive the proper vehicle speed signal (input by CAN communication) from ABS actuator and electric unit (control unit).

Possible Cause

INFOID:000000004407231

- Harness or connectors
(Sensor circuit is open or shorted.)
- ABS actuator and electric unit (control unit)

DTC Confirmation Procedure

INFOID:000000004407232

CAUTION:

Always drive vehicle at a safe speed.

NOTE:

If "DTC Confirmation Procedure" has been previously performed, always turn ignition switch OFF and wait at least 10 seconds before performing the next test.

After the repair, touch "ERASE" on "SELF-DIAG RESULTS" and then perform the following procedure to confirm the malfunction is eliminated.

Ⓟ WITH CONSULT-III

1. Turn ignition switch ON.
2. Select "DATA MONITOR" mode for "TRANSMISSION" with CONSULT-III.
3. Start engine and maintain the following conditions for at least 5 consecutive seconds.
ACC PEDAL OPEN: 1.0/8 or less
VEHICLE SPEED SE: 30 km/h (19 MPH) or more
4. If DTC is detected, go to [CVT-124. "Diagnosis Procedure"](#).

Diagnosis Procedure

INFOID:000000004407233

1. CHECK CAN COMMUNICATION LINE

Perform the self-diagnosis check. Refer to [CVT-47. "CONSULT-III Function \(TRANSMISSION\)"](#).

Is any malfunction of the "U1000 CAN COMM CIRCUIT" indicated?

- YES >> Check CAN communication line. Refer to [CVT-55](#).
NO >> GO TO 2.

2. CHECK ABS ACTUATOR AND ELECTRIC UNIT (CONTROL UNIT)

Perform ABS actuator and electric unit (control unit) self-diagnosis check. Refer to [BRC-18. "CONSULT-III Function \(ABS\)"](#).

OK or NG

- OK >> GO TO 3.
NG >> Repair or replace damaged parts.

DTC P1722 ESTM VEHICLE SPEED SIGNAL

< SERVICE INFORMATION >

3. CHECK INPUT SIGNALS

With CONSULT-III

1. Start engine.
2. Select "SELECTION FROM MENU" in "DATA MONITOR" mode for "TRANSMISSION" with CONSULT-III.
3. Drive vehicle and read out the value of "VEHICLE SPEED" and "ESTM VSP SIG".

Item name	Condition	Display value
ESTM VSP SIG	During driving	Approximately matches the speedometer reading.
VEHICLE SPEED		

4. Check if there is a great difference between the two values.

OK or NG

- OK >> GO TO 5.
NG >> GO TO 4.

4. CHECK TCM

Check TCM input/output signals. Refer to [CVT-45, "TCM Input/Output Signal Reference Value"](#).

OK or NG

- OK >> GO TO 5.
NG >> Repair or replace damaged parts.

5. CHECK DTC

Perform [CVT-124, "DTC Confirmation Procedure"](#).

OK or NG

- OK >> **INSPECTION END**
NG >> GO TO 2.

A
B
CVT
D
E
F
G
H
I
J
K
L
M
N
O
P

DTC P1723 CVT SPEED SENSOR FUNCTION

< SERVICE INFORMATION >

DTC P1723 CVT SPEED SENSOR FUNCTION

Description

INFOID:000000004407234

- The vehicle speed sensor CVT [output speed sensor (secondary speed sensor)] detects the revolution of the parking gear and generates a pulse signal. The pulse signal is sent to the TCM, which converts it into vehicle speed.
- The input speed sensor (primary speed sensor) detects the primary pulley revolution speed and sends a signal to the TCM.

On Board Diagnosis Logic

INFOID:000000004407235

- This is not an OBD-II self-diagnostic item.
- Diagnostic trouble code "P1723 CVT SPD SEN/FNCTN" with CONSULT-III is detected when there is a great difference between the vehicle speed signal and the secondary speed sensor signal.

CAUTION:

One of the "P0720 VEH SPD SEN/CIR AT", the "P0715 INPUT SPD SEN/CIRC" or the "P0725 ENGINE SPEED SIG" is displayed with the DTC at the same time.

Possible Cause

INFOID:000000004407236

- Harness or connectors
(Sensor circuit is open or shorted.)
- Output speed sensor (Secondary speed sensor)
- Input speed sensor (Primary speed sensor)
- Engine speed signal system

DTC Confirmation Procedure

INFOID:000000004407237

CAUTION:

Always drive vehicle at a safe speed.

NOTE:

If "DTC Confirmation Procedure" has been previously performed, always turn ignition switch OFF and wait at least 10 seconds before performing the next test.

After the repair, touch "ERASE" on "SELF-DIAG RESULTS" and then perform the following procedure to confirm the malfunction is eliminated.

Ⓟ WITH CONSULT-III

1. Turn ignition switch ON and select "DATA MONITOR" mode for "TRANSMISSION" with CONSULT-III.
2. Start engine and maintain the following conditions for at least 5 consecutive seconds.
VEHICLE SPEED SE: 10 km/h (6 MPH) or more
ACC PEDAL OPEN: More than 1.0/8
RANGE: "D" position
ENG SPEED: 450 rpm or more
Driving location: Driving the vehicle uphill (increased engine load) will help maintain the driving conditions required for this test.
3. If DTC is detected, go to [CVT-126. "Diagnosis Procedure"](#).

Diagnosis Procedure

INFOID:000000004407238

1. CHECK STEP MOTOR FUNCTION

Perform the self-diagnosis check. Refer to [CVT-47. "CONSULT-III Function \(TRANSMISSION\)"](#).

Is a malfunction in the step motor function indicated in the results?

- YES >> Repair or replace damaged parts. (Check the step motor function. Refer to [CVT-139](#).)
- NO >> GO TO 2.

2. CHECK OUTPUT SPEED SENSOR (SECONDARY SPEED SENSOR SYSTEM) AND INPUT SPEED SENSOR (PRIMARY SPEED SENSOR) SYSTEM

Check output speed sensor (secondary speed sensor) system and input speed sensor (primary speed sensor) system. Refer to [CVT-76](#), [CVT-71](#).

OK or NG

DTC P1723 CVT SPEED SENSOR FUNCTION

< SERVICE INFORMATION >

- OK >> GO TO 3.
NG >> Repair or replace damaged parts.

A

3.CHECK ENGINE SPEED SIGNAL SYSTEM

Check engine speed signal system. Refer to [CVT-81](#).

B

OK or NG

- OK >> GO TO 4.
NG >> Repair or replace damaged parts. Refer to [EC-551](#).

CVT

4.DETECT MALFUNCTIONING ITEM

Check the following:

- Power supply and ground circuit for TCM. Refer to [CVT-118](#).
- The TCM pin terminals for damage or loose connection with harness connector.

D

OK or NG

- OK >> GO TO 5.
NG >> Repair or replace damaged parts.

E

5.CHECK DTC

Perform [CVT-126, "DTC Confirmation Procedure"](#).

F

OK or NG

- OK >> **INSPECTION END**
NG >> Replace TCM or transaxle assembly. Refer to [CVT-8, "Service After Replacing TCM and Transaxle Assembly"](#), [CVT-190, "Removal and Installation \(MR20DE\)"](#).

G

H

I

J

K

L

M

N

O

P

DTC P1726 ELECTRIC THROTTLE CONTROL SYSTEM

< SERVICE INFORMATION >

DTC P1726 ELECTRIC THROTTLE CONTROL SYSTEM

Description

INFOID:000000004407239

Electric throttle control actuator consists of throttle control motor, accelerator pedal position sensor, throttle position sensor etc. The actuator sends a signal to the ECM, and ECM sends the signal to TCM with CAN communication.

On Board Diagnosis Logic

INFOID:000000004407240

- This is not an OBD-II self-diagnostic item.
- Diagnostic trouble code "P1726 ELEC TH CONTROL" with CONSULT-III is detected when the electronically controlled throttle for ECM is malfunctioning.

Possible Cause

INFOID:000000004407241

Harness or connectors
(Sensor circuit is open or shorted.)

DTC Confirmation Procedure

INFOID:000000004407242

NOTE:

If "DTC Confirmation Procedure" has been previously performed, always turn ignition switch OFF and wait at least 10 seconds before performing the next test.

After the repair, touch "ERASE" on "SELF-DIAG RESULTS" and then perform the following procedure to confirm the malfunction is eliminated.

Ⓟ WITH CONSULT-III

1. Turn ignition switch ON.
2. Select "DATA MONITOR" mode for "TRANSMISSION" with CONSULT-III.
3. Start engine and let it idle for 5 second.
4. If DTC is detected, go to [CVT-128, "Diagnosis Procedure"](#).

Diagnosis Procedure

INFOID:000000004407243

1.CHECK DTC WITH ECM

Ⓟ With CONSULT-III

1. Turn ignition switch ON.
2. Select "SELF-DIAG RESULTS" mode for "ENGINE" with CONSULT-III. Refer to [EC-123, "CONSULT-III Function \(ENGINE\)"](#).

OK or NG

- OK >> GO TO 2.
NG >> Check the DTC Detected Item. Refer to [EC-123, "CONSULT-III Function \(ENGINE\)"](#).
• If CAN communication line is detected, go to [CVT-55](#).

2.CHECK DTC

Perform [CVT-128, "DTC Confirmation Procedure"](#).

OK or NG

- OK >> **INSPECTION END**
NG >> GO TO 3.

3.DETECT MALFUNCTIONING ITEM

Check the following:

- The TCM pin terminals for damage or loose connection with harness connector.

OK or NG

- OK >> Replace TCM. Refer to [CVT-8, "Service After Replacing TCM and Transaxle Assembly"](#).
NG >> Repair or replace damaged parts.

DTC P1740 LOCK-UP SELECT SOLENOID VALVE CIRCUIT

< SERVICE INFORMATION >

DTC P1740 LOCK-UP SELECT SOLENOID VALVE CIRCUIT

Description

INFOID:000000004407244

- The lock-up select solenoid valve controls lock-up clutch pressure or forward clutch pressure (reverse brake pressure).
- When controlling lock-up clutch, the valve is turned OFF. When controlling forward clutch, it is turned ON.

CONSULT-III Reference Value

INFOID:000000004407245

Item name	Condition	Display value
LUSEL SOL OUT	Selector lever in "P" and "N" positions	ON
	Wait at least for 5 seconds with the selector lever in "R", "D" and "L" positions	OFF
LUSEL SOL MON	Selector lever in "P", "N" positions	ON
	Wait at least for 5 seconds with the selector lever in "R", "D" or "L" position	OFF

On Board Diagnosis Logic

INFOID:000000004407246

- This is an OBD-II self-diagnostic item.
- Diagnostic trouble code "P1740 LU-SLCT SOL/CIRC" with CONSULT-III is detected under the following conditions.
 - When TCM compares target value with monitor value and detects an irregularity.

Possible Cause

INFOID:000000004407247

- Lock-up select solenoid valve
- Harness or connectors
(Solenoid circuit is open or shorted.)

DTC Confirmation Procedure

INFOID:000000004407248

CAUTION:

Always drive vehicle at a safe speed.

NOTE:

If "DTC Confirmation Procedure" has been previously performed, always turn ignition switch OFF and wait at least 10 seconds before performing the next test.

After the repair, touch "ERASE" on "SELF-DIAG RESULTS" and then perform the following procedure to confirm the malfunction is eliminated.

WITH CONSULT-III

1. Turn ignition switch ON.
2. Select "DATA MONITOR" mode for "TRANSMISSION" with CONSULT-III.
3. Start engine and maintain the following conditions for at least 5 consecutive seconds.
RANGE: "D" position and "N" position
(At each time, wait for 5 seconds.)
4. If DTC is detected, go to [CVT-131, "Diagnosis Procedure"](#).

WITH GST

Follow the procedure "WITH CONSULT-III".

DTC P1740 LOCK-UP SELECT SOLENOID VALVE CIRCUIT

< SERVICE INFORMATION >

Wiring Diagram - CVT - L/USSV

INFOID:000000004407249

CVT-L/USSV-01

— : DETECTABLE LINE FOR DTC
 — : NON-DETECTABLE LINE FOR DTC

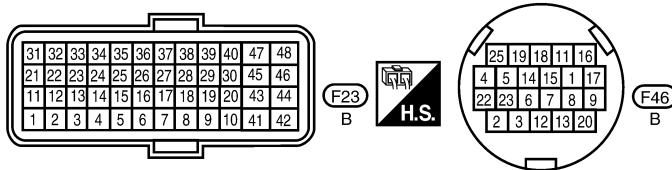
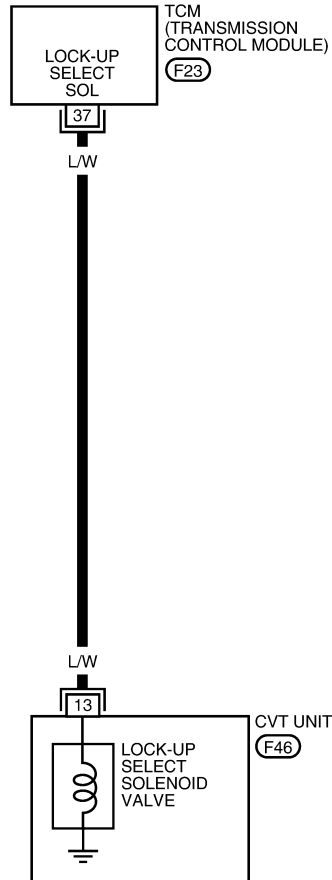

BCWA0747E

TCM TERMINALS AND REFERENCE VALUES

Refer to [CVT-45, "TCM Input/Output Signal Reference Value"](#).

DTC P1740 LOCK-UP SELECT SOLENOID VALVE CIRCUIT

< SERVICE INFORMATION >

Diagnosis Procedure

INFOID:000000004407250

1. CHECK INPUT SIGNAL

With CONSULT-III

1. Turn ignition switch ON.
2. Select "SELECTION FROM MENU" in "DATA MONITOR" mode for "TRANSMISSION" with CONSULT-III.
3. Read out the value of "LUSEL SOL OUT" and "LUSEL SOL MON".

Item name	Condition	Display value
LUSEL SOL OUT	Selector lever in "P" and "N" positions	ON
	Wait at least for 5 seconds with the selector lever in "R", "D" and "L" positions	OFF
LUSEL SOL MON	Selector lever in "P" and "N" positions	ON
	Wait at least for 5 seconds with the selector lever in "R", "D" and "L" positions	OFF

Without CONSULT-III

1. Turn ignition switch ON.
2. Check voltage between TCM connector terminal and ground.

Name	Connector	Terminal	Condition	Voltage (Approx.)
Lock-up select solenoid valve	F23	37 - Ground	Selector lever in "P" and "N" positions	Battery voltage
			Wait at least for 5 seconds with the selector lever in "R", "D" and "L" positions	0 V

3. Turn ignition switch OFF.
4. Disconnect the TCM connector.
5. Check if there is continuity between connector terminal and ground.

OK or NG

- OK >> GO TO 5.
 NG >> GO TO 2.

2. CHECK LOCK-UP SELECT SOLENOID VALVE CIRCUIT

1. Turn ignition switch OFF.
2. Disconnect TCM connector.
3. Check resistance between TCM connector terminal and ground.

Solenoid valve	Connector	Terminal	Resistance (Approx.)
Lock-up select solenoid valve	F23	37 - Ground	17 - 38 Ω

OK or NG

- OK >> GO TO 5.
 NG >> GO TO 3.

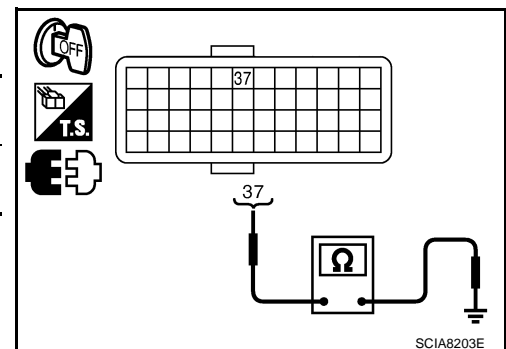

3. CHECK VALVE RESISTANCE

1. Turn ignition switch OFF.
2. Disconnect CVT unit harness connector.

DTC P1740 LOCK-UP SELECT SOLENOID VALVE CIRCUIT

< SERVICE INFORMATION >

3. Check resistance between CVT unit harness connector terminal and ground.

Solenoid valve	Connector	Terminal	Resistance (Approx.)
Lock-up select solenoid valve	F46	13 - Ground	17 - 38 Ω

OK or NG

- OK >> GO TO 4.
- NG >> Replace the transaxle assembly. Refer to [CVT-190, "Removal and Installation \(MR20DE\)"](#).

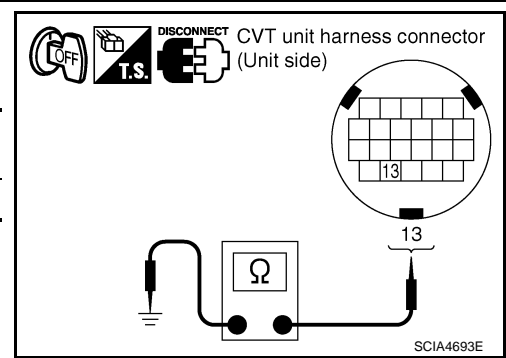

4. CHECK HARNESS BETWEEN TCM AND LOCK-UP SELECT SOLENOID VALVE

1. Turn ignition switch OFF.
2. Disconnect TCM connector (A) and CVT harness connector (B).
3. Check continuity between TCM connector (A) terminal and CVT unit harness connector (B) terminal.

Item	Connector	Terminal	Continuity
TCM	F23	37	Yes
CVT unit harness connector	F46	13	

4. If OK, check harness for short to ground and short to power.
5. Reinstall any part removed.

OK or NG

- OK >> GO TO 5.
- NG >> Repair open circuit or short to ground or short to power in harness or connectors.

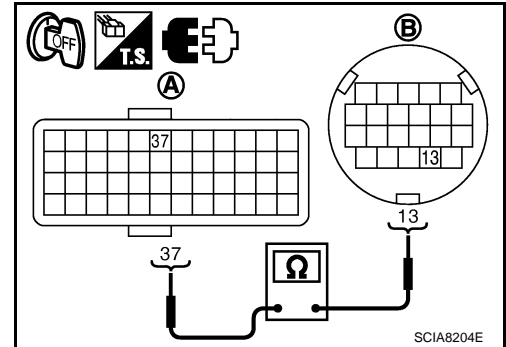

5. CHECK DTC

Perform [CVT-129, "DTC Confirmation Procedure"](#).

OK or NG

- OK >> **INSPECTION END**
- NG >> GO TO 6.

6. CHECK TCM

1. Check TCM input/output signals. Refer to [CVT-45, "TCM Input/Output Signal Reference Value"](#).
2. If NG, re-check TCM pin terminals for damage or loose connection with harness connector.

OK or NG

- OK >> **INSPECTION END**
- NG >> 1. Repair or replace damaged parts.
2. Replace TCM. Refer to [CVT-8, "Service After Replacing TCM and Transaxle Assembly"](#).

Component Inspection

INFOID:000000004407251

LOCK-UP SELECT SOLENOID VALVE

1. Turn ignition switch OFF.
2. Disconnect CVT unit harness connector.

DTC P1740 LOCK-UP SELECT SOLENOID VALVE CIRCUIT

< SERVICE INFORMATION >

3. Check resistance between CVT unit harness connector terminal and ground.

Solenoid valve	Connector	Terminal	Resistance (Approx.)
Lock-up select solenoid valve	F46	13 - Ground	17 - 38 Ω

4. If NG, replace the transaxle assembly. Refer to [CVT-190](#), "[Removal and Installation \(MR20DE\)](#)".

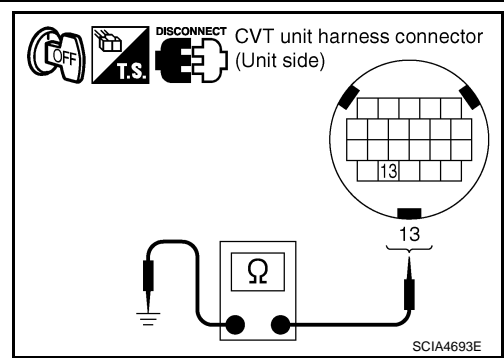

A

B

CVT

D

E

F

G

H

I

J

K

L

M

N

O

P

DTC P1745 LINE PRESSURE CONTROL

< SERVICE INFORMATION >

DTC P1745 LINE PRESSURE CONTROL

Description

INFOID:000000004407252

The pressure control solenoid valve A (line pressure solenoid valve) regulates the oil pump discharge pressure to suit the driving condition in response to a signal sent from the TCM.

On Board Diagnosis Logic

INFOID:000000004407253

- This is not an OBD-II self-diagnostic item.
- Diagnostic trouble code "P1745 L/PRESS CONTROL" with CONSULT-III is detected when TCM detects the unexpected line pressure.

Possible Cause

INFOID:000000004407254

TCM

DTC Confirmation Procedure

INFOID:000000004407255

NOTE:

If "DTC Confirmation Procedure" has been previously performed, always turn ignition switch OFF and wait at least 10 seconds before performing the next test.

After the repair, touch "ERASE" on "SELF-DIAG RESULTS" and then perform the following procedure to confirm the malfunction is eliminated.

Ⓟ WITH CONSULT-III

1. Turn ignition switch ON and select "DATA MONITOR" mode for "TRANSMISSION" with CONSULT-III.
2. Make sure that output voltage of CVT fluid temperature sensor is within the range below.
ATF TEMP SEN: 1.0 - 2.0 V
If out of range, drive the vehicle to decrease the voltage (warm up the fluid) or stop engine to increase the voltage (cool down the fluid)
3. If DTC is detected, go to [CVT-134, "Diagnosis Procedure"](#).

Diagnosis Procedure

INFOID:000000004407256

1. CHECK DTC

1. Turn ignition switch ON.
2. Select "SELF-DIAG RESULTS" mode for "TRANSMISSION" with CONSULT-III.
3. Erase self-diagnostic results.
4. Turn ignition switch OFF, and wait for 10 seconds or more.
5. Start engine.
6. Confirm self-diagnostic results again. Refer to [CVT-47, "CONSULT-III Function \(TRANSMISSION\)"](#).

Is the "P1745 L/PRESS CONTROL" displayed?

- YES >> Replace TCM. Refer to [CVT-8, "Service After Replacing TCM and Transaxle Assembly"](#).
NO >> **INSPECTION END**

DTC P1777 STEP MOTOR - CIRCUIT

< SERVICE INFORMATION >

DTC P1777 STEP MOTOR - CIRCUIT

Description

INFOID:000000004407257

- The step motor changes the step with turning 4 coils ON/OFF according to the signal from TCM. As a result, the flow of line pressure to primary pulley is changed and pulley ratio is controlled

CONSULT-III Reference Value

INFOID:000000004407258

Remarks: Specification data are reference values.

Item name	Condition	Display value (Approx.)
STM STEP	During driving	0 step - 177 step
SMCOIL A		Changes ON⇔OFF.
SMCOIL B		
SMCOIL C		
SMCOIL D		

On Board Diagnosis Logic

INFOID:000000004407259

- This is an OBD-II self-diagnostic item.
- Diagnostic trouble code "P1777 STEP MOTR CIRC" with CONSULT-III is detected under the following conditions.
 - When operating step motor ON and OFF, there is no proper change in the voltage of TCM terminal which corresponds to it.

Possible Cause

INFOID:000000004407260

- Step motor
- Harness or connectors
(Step motor circuit is open or shorted.)

DTC Confirmation Procedure

INFOID:000000004407261

CAUTION:

Always drive vehicle at a safe speed.

NOTE:

If "DTC Confirmation Procedure" has been previously performed, always turn ignition switch OFF and wait at least 10 seconds before performing the next test.

After the repair, touch "ERASE" on "SELF-DIAG RESULTS" and then perform the following procedure to confirm the malfunction is eliminated.

WITH CONSULT-III

1. Turn ignition switch ON and select "DATA MONITOR" mode for "TRANSMISSION" with CONSULT-III.
2. Drive vehicle for at least 5 consecutive seconds.
3. If DTC is detected, go to [CVT-137, "Diagnosis Procedure"](#).

WITH GST

Follow the procedure "WITH CONSULT-III".

DTC P1777 STEP MOTOR - CIRCUIT

< SERVICE INFORMATION >

Wiring Diagram - CVT - STM

INFOID:000000004407262

CVT-STM-01

: DETECTABLE LINE FOR DTC
 : NON-DETECTABLE LINE FOR DTC

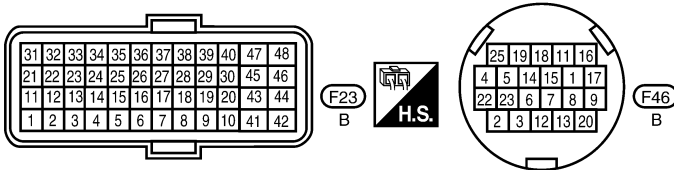
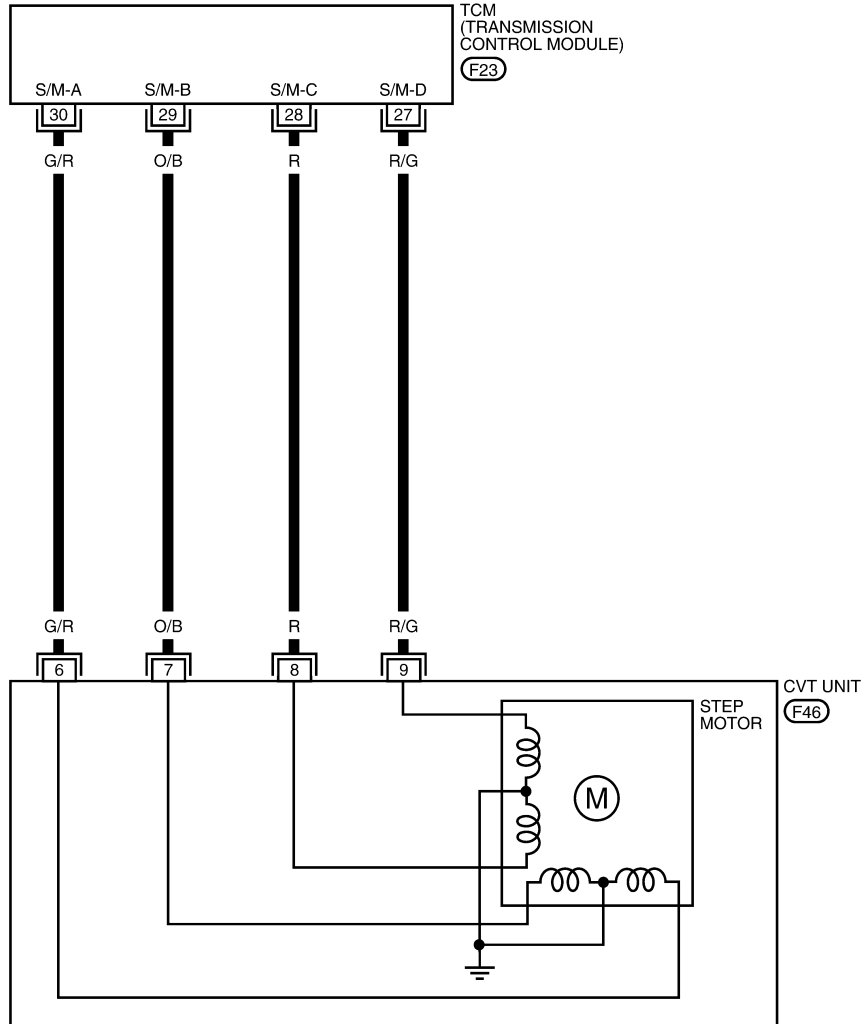

BCWA0748E

TCM TERMINALS AND REFERENCE VALUES

Refer to [CVT-45, "TCM Input/Output Signal Reference Value"](#).

DTC P1777 STEP MOTOR - CIRCUIT

< SERVICE INFORMATION >

Diagnosis Procedure

INFOID:000000004407263

1. CHECK INPUT SIGNALS

With CONSULT-III

1. Start engine.
2. Select "SELECTION FROM MENU" in "DATA MONITOR" mode for "TRANSMISSION" with CONSULT-III.
3. Start vehicle and read out the value of "STM STEP", "SMCOIL A", "SMCOIL B", "SMCOIL C", and "SMCOIL D".

Item name	Condition	Display value (Approx.)
STM STEP	During driving	0 step - 177 step
SMCOIL A		Changes ON⇔OFF.
SMCOIL B		
SMCOIL C		
SMCOIL D		

OK or NG

- OK >> GO TO 4.
 NG >> GO TO 2.

2. CHECK HARNESS BETWEEN TCM AND STEP MOTOR

1. Turn ignition switch OFF.
2. Disconnect CVT unit connector and TCM connector (A).
3. Check continuity between TCM connector (A) terminals and CVT unit harness connector (B) terminals.

Item	Connector	Terminal	Continuity
TCM	F23	30	Yes
CVT unit harness connector	F46	6	
TCM	F23	29	Yes
CVT unit harness connector	F46	7	
TCM	F23	28	Yes
CVT unit harness connector	F46	8	
TCM	F23	27	Yes
CVT unit harness connector	F46	9	

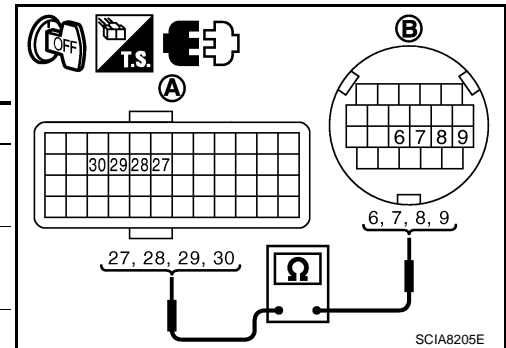

4. If OK, check harness for short to ground and short to power.
5. If OK, check continuity between body ground and CVT assembly.
6. Reinstall any part removed.

OK or NG

- OK >> GO TO 3.
 NG >> Repair open circuit or short to ground or short to power in harness or connectors.

3. CHECK STEP MOTOR

Check step motor. Refer to [CVT-138. "Component Inspection"](#).

OK or NG

- OK >> GO TO 4.
 NG >> Repair or replace damaged parts.

4. CHECK DTC

Perform [CVT-135. "DTC Confirmation Procedure"](#).

OK or NG

- OK >> **INSPECTION END**
 NG >> GO TO 5.

DTC P1777 STEP MOTOR - CIRCUIT

< SERVICE INFORMATION >

5. CHECK TCM

1. Check TCM input/output signals. Refer to [CVT-45, "TCM Input/Output Signal Reference Value"](#).
2. If NG, re-check TCM pin terminals for damage or loose connection with harness connector.

OK or NG

- OK >> **INSPECTION END**
- NG >> Repair or replace damaged parts.

Component Inspection

INFOID:000000004407264

STEP MOTOR

1. Turn ignition switch OFF.
2. Disconnect CVT unit harness connector.
3. Check resistance between CVT unit harness connector terminals and ground.

Name	Connector	Terminal	Resistance (Approx.)
Step motor	F46	6 - 7	30 Ω
		8 - 9	
		6 - Ground	15 Ω
		7 - Ground	
		8 - Ground	
		9 - Ground	

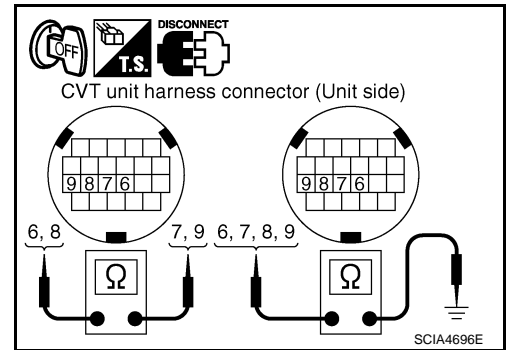

4. If NG, replace the transaxle assembly. Refer to [CVT-190, "Removal and Installation \(MR20DE\)"](#).

DTC P1778 STEP MOTOR - FUNCTION

< SERVICE INFORMATION >

DTC P1778 STEP MOTOR - FUNCTION

Description

INFOID:000000004407265

- The step motor's 4 aspects of ON/OFF change according to the signal from TCM. As a result, the flow of line pressure to primary pulley is changed and pulley ratio is controlled.
- This diagnosis item is detected when electrical system is OK, but mechanical system is NG.
- This diagnosis item is detected when the state of the changing the speed mechanism in unit does not operate normally.

CONSULT-III Reference Value

INFOID:000000004407266

Remarks: Specification data are reference values.

Item name	Condition	Display value (Approx.)
STM STEP	During driving	0 step - 177 step
GEAR RATIO		2.34 - 0.39

On Board Diagnosis Logic

INFOID:000000004407267

- This is an OBD-II self-diagnostic item.
- Diagnostic trouble code "P1778 STEP MOTR/FNC" with CONSULT-III is detected under the following conditions.
 - When not changing the pulley ratio according to the instruction of TCM.

Possible Cause

INFOID:000000004407268

Step motor

DTC Confirmation Procedure

INFOID:000000004407269

CAUTION:

- Always drive vehicle at a safe speed.
- Before starting "DTC Confirmation Procedure", confirm "Hi" or "Mid" or "Low" fixation by "PRI SPEED" and "VEHICLE SPEED" on "DATA MONITOR MODE".
- If hi-gear fixation occurred, go to [CVT-140. "Diagnosis Procedure"](#).

NOTE:

If "DTC Confirmation Procedure" has been previously performed, always turn ignition switch OFF and wait at least 10 seconds before performing the next test.

After the repair, touch "ERASE" on "SELF-DIAG RESULTS" and then perform the following procedure to confirm the malfunction is eliminated.

④ WITH CONSULT-III

1. Turn ignition switch ON and select "DATA MONITOR" mode for "TRANSMISSION" with CONSULT-III.
2. Make sure that output voltage of CVT fluid temperature sensor is within the range below.
ATF TEMP SEN: 1.0 - 2.0 V
If out of range, drive the vehicle to decrease the voltage (warm up the fluid) or stop engine to increase the voltage (cool down the fluid)
3. Select "DATA MONITOR" mode for "TRANSMISSION" with CONSULT-III.
4. Start engine and maintain the following conditions for at least 30 consecutive seconds.
TEST START FROM 0 km/h (0 MPH)
CONSTANT ACCELERATION: Keep 30 sec or more
VEHICLE SPEED: 10 km/h (6 MPH) or more
ACC PEDAL OPEN: More than 1.0/8
RANGE: "D" position
ENG SPEED: 450 rpm or more
5. If DTC is detected, go to [CVT-140. "Diagnosis Procedure"](#).

④ WITH GST

Follow the procedure "WITH CONSULT-III".

DTC P1778 STEP MOTOR - FUNCTION

< SERVICE INFORMATION >

Diagnosis Procedure

INFOID:000000004407270

1. CHECK STEP MOTOR

With CONSULT-III

It is monitoring whether "GEAR RATIO: 2.34 - 0.39" changes similarly to "STM STEP: 0 - 177" by DATA MONITOR mode. Refer to [CVT-47, "CONSULT-III Function \(TRANSMISSION\)"](#).

Without CONSULT-III

Inspect the engine speed (rise and descend), vehicle speed, throttle position, and check shift change. Refer to [CVT-196, "Vehicle Speed When Shifting Gears"](#).

OK or NG

OK >> **INSPECTION END**

NG >> Replace the transaxle assembly. Refer to [CVT-190, "Removal and Installation \(MR20DE\)"](#).

OVERDRIVE CONTROL SWITCH

< SERVICE INFORMATION >

OVERDRIVE CONTROL SWITCH

Description

INFOID:000000004407271

- Overdrive control switch is installed to the selector lever.
- O/D OFF indicator turns ON, and overdrive driving activates when pressing the overdrive control switch while driving in "D" position. O/D OFF indicator turns OFF, and "D" position driving starts when pressing the overdrive control switch while driving in the overdrive-off mode. Shifting the selector lever in any position other than "D" releases the overdrive-off mode.

CONSULT-III Reference Value

INFOID:000000004407272

Item name	Condition	Display value
SPORT MODE SW	When OD OFF indicator lamp is off.	ON
	When OD OFF indicator lamp is on.	OFF

A

B

CVT

D

E

F

G

H

I

J

K

L

M

N

O

P

OVERDRIVE CONTROL SWITCH

< SERVICE INFORMATION >

Wiring Diagram - CVT - ODSW

INFOID:000000004407273

CVT-ODSW-01

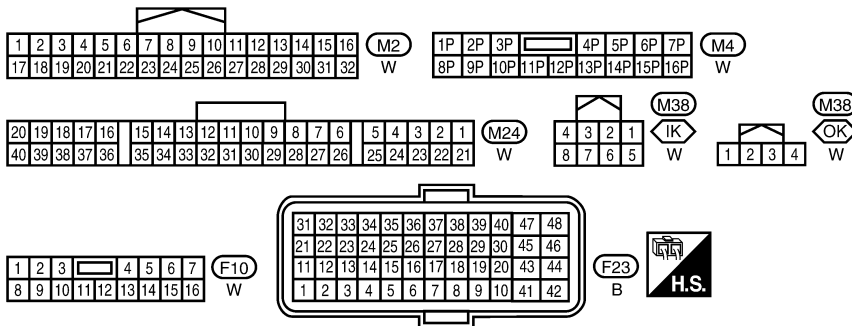
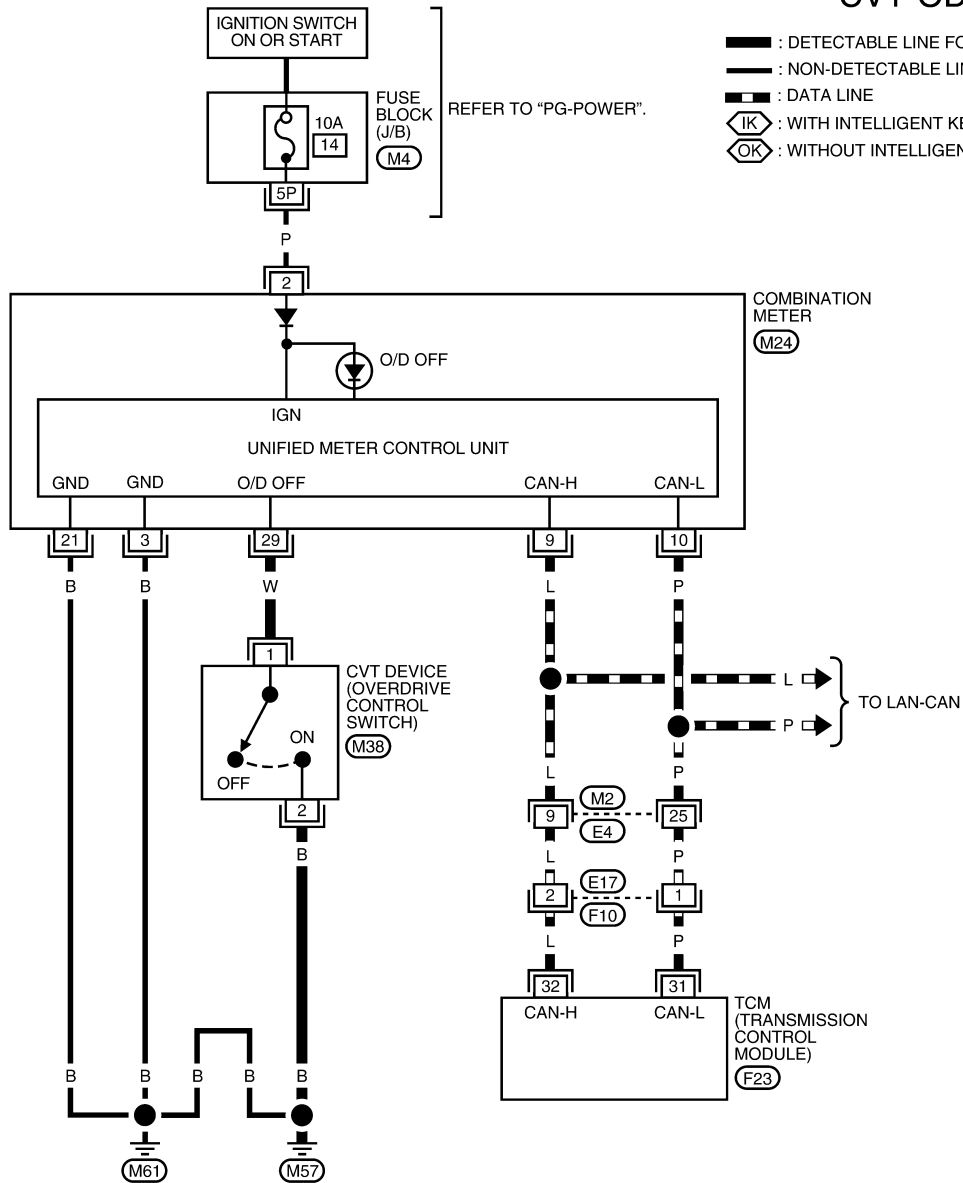

BCWA0749E

TCM TERMINALS AND REFERENCE VALUES

Refer to [CVT-45, "TCM Input/Output Signal Reference Value"](#).

OVERDRIVE CONTROL SWITCH

< SERVICE INFORMATION >

Diagnosis Procedure

INFOID:000000004407274

1. CHECK CAN COMMUNICATION LINE

Perform the self-diagnosis check. Refer to [CVT-47, "CONSULT-III Function \(TRANSMISSION\)"](#).

Is any malfunction of the "U1000 CAN COMM CIRCUIT" indicated in the results?

- YES >> Check CAN communication line. Refer to [CVT-55](#).
- NO >> GO TO 2.

2. CHECK OVERDRIVE CONTROL SWITCH SIGNAL

Ⓜ With CONSULT-III

1. Turn ignition switch ON.
2. Select "ECU INPUT SIGNALS" in "DATA MONITOR" mode for "TRANSMISSION" with CONSULT-III.
3. Read out ON/OFF switching action of the "SPORT MODE SW".

Item name	Condition	Display value
SPORT MODE SW	While pushing overdrive cancel switch	ON
	Other conditions	OFF

OK or NG

- OK >> **INSPECTION END**
- NG >> GO TO 3.

3. CHECK OVERDRIVE CONTROL SWITCH

Check overdrive control switch. Refer to [CVT-144, "Component Inspection"](#).

OK or NG

- OK >> GO TO 4.
- NG >> Repair or replace damaged parts.

4. CHECK SELF-DIAGNOSTIC RESULTS (COMBINATION METER)

Perform self-diagnosis check. Refer to [DI-13, "Self-Diagnosis Mode of Combination Meter"](#).

Is any malfunction detected by self-diagnostic?

- YES >> Check the malfunctioning system.
- NO - 1 >> With Intelligent Key: GO TO 5.
- NO - 2 >> Without Intelligent Key: GO TO 6.

5. CHECK OVERDRIVE CONTROL SWITCH CIRCUIT WITH INTELLIGENT KEY

1. Turn ignition switch OFF.
2. Disconnect CVT device connector and combination meter connector.
3. Check continuity between CVT device harness connector (A) terminal and combination meter harness connector (B) terminal.

Item	Connector	Terminal	Continuity
CVT device harness connector	M38	1	Yes
Combination meter harness connector	M24	29	

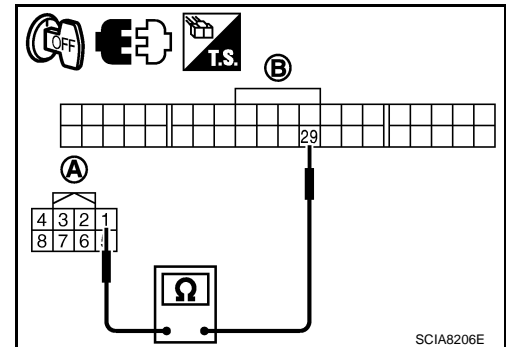

OVERDRIVE CONTROL SWITCH

< SERVICE INFORMATION >

4. Check continuity between CVT device harness connector terminal and ground.

Item	Connector	Terminal	Continuity
CVT device harness connector	M38	2 - ground	Yes

5. If OK, check harness for short to ground and short to power.
6. Reinstall any part removed.

OK or NG

OK >> **INSPECTION END**

NG >> Repair open circuit or short to ground or short to power in harness or connectors.

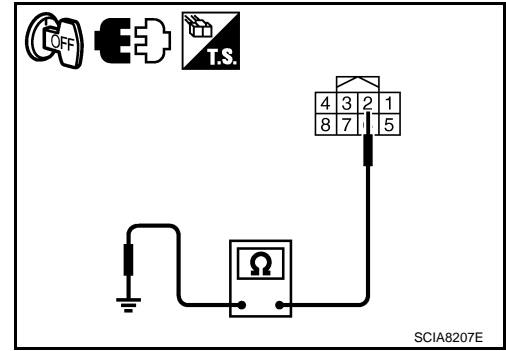

6. CHECK OVERDRIVE CONTROL SWITCH CIRCUIT WITHOUT INTELLIGENT KEY

1. Turn ignition switch OFF.
2. Disconnect CVT device connector and combination meter connector.
3. Check continuity between CVT device harness connector (A) terminal and combination meter harness connector (B) terminal.

Item	Connector	Terminal	Continuity
CVT device harness connector	M38	1	Yes
Combination meter harness connector	M24	29	

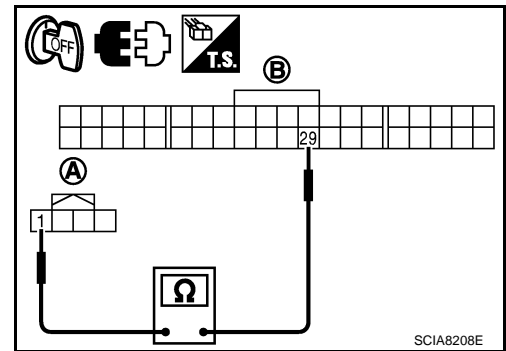

4. Check continuity between CVT device harness connector terminal and ground.

Item	Connector	Terminal	Continuity
CVT device harness connector	M38	2 - ground	Yes

5. If OK, check harness for short to ground and short to power.
6. Reinstall any part removed.

OK or NG

OK >> **INSPECTION END**

NG >> Repair open circuit or short to ground or short to power in harness or connectors.

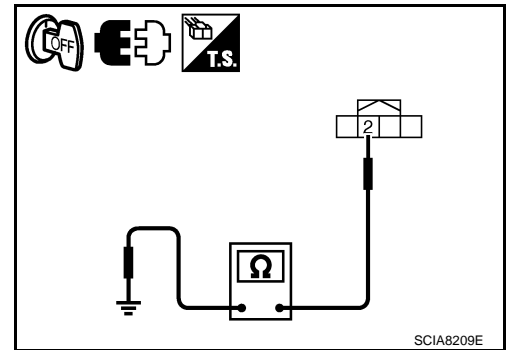

Component Inspection

INFOID:000000004407275

OVERDRIVE CONTROL SWITCH

With Intelligent Key

Check continuity between CVT device harness connector terminals.

Item	Condition	Terminal	Continuity
Overdrive control switch	While pushing overdrive control switch	1 - 2	Yes
	Other conditions		No

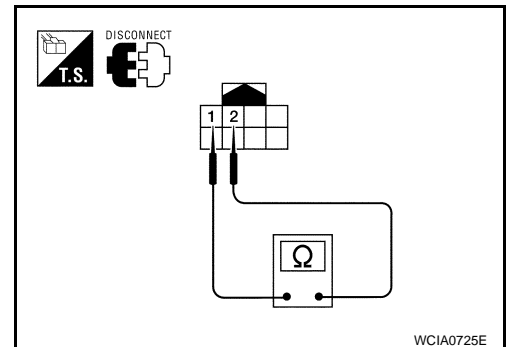

Without Intelligent Key

OVERDRIVE CONTROL SWITCH

< SERVICE INFORMATION >

Check continuity between CVT device harness connector terminals.

Item	Condition	Terminal	Continuity
Overdrive control switch	While pushing overdrive control switch	1 - 2	Yes
	Other conditions		No

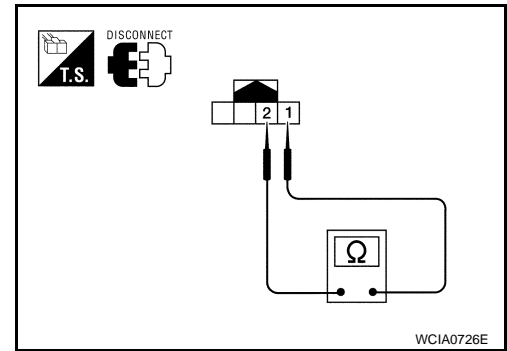

A

B

CVT

D

E

F

G

H

I

J

K

L

M

N

O

P

SHIFT POSITION INDICATOR CIRCUIT

< SERVICE INFORMATION >

SHIFT POSITION INDICATOR CIRCUIT

Description

INFOID:000000004407276

TCM sends the switch signals to combination meter via CAN communication line. Then selector lever position is indicated on the shift position indicator.

CONSULT-III Reference Value

INFOID:000000004407277

Item name	Condition	Display value
RANGE	Selector lever in "N" or "P" position.	N-P
	Selector lever in "R" position.	R
	Selector lever in "D" position.	D
	Selector lever in "L" position.	L

Diagnosis Procedure

INFOID:000000004407278

1. CHECK INPUT SIGNALS

Ⓜ With CONSULT-III

1. Start engine.
2. Select "MAIN SIGNALS" in "DATA MONITOR" mode for "TRANSMISSION" with CONSULT-III and read out the value of "RANGE".
3. Check that the following three positions or indicators are same.
 - Actual position of the selector lever
 - "RANGE" on CONSULT-III screen
 - Shift position indicator in the combination meter

OK or NG

OK >> **INSPECTION END**

NG >> Check the following.

SHIFT POSITION INDICATOR SYMPTOM CHART

Items	Presumed location of trouble
Actual position does not change.	Park/neutral position switch <ul style="list-style-type: none">• Refer to CVT-61.CVT main system (Fail-safe function actuated)• Refer to CVT-47, "CONSULT-III Function (TRANSMISSION)".
Shift position indicator in the combination meter does not indicate any position.	Perform the self-diagnosis for CVT and the combination meter. <ul style="list-style-type: none">• Refer to CVT-47, "CONSULT-III Function (TRANSMISSION)" and DI-5.
Actual position changes, but the shift position indicator in the combination meter does not change.	
Actual position differs from the shift position indicator in the combination meter.	
Shift position indicator in the combination meter does not indicate specific position only.	Check the combination meter. <ul style="list-style-type: none">• Refer to DI-5.

TROUBLE DIAGNOSIS FOR SYMPTOMS



< SERVICE INFORMATION >

TROUBLE DIAGNOSIS FOR SYMPTOMS

Wiring Diagram - CVT - NONDTC

INFOID:000000004407279

CVT-NONDTC-01

-  : DETECTABLE LINE FOR DTC
-  : NON-DETECTABLE LINE FOR DTC
-  : DATA LINE

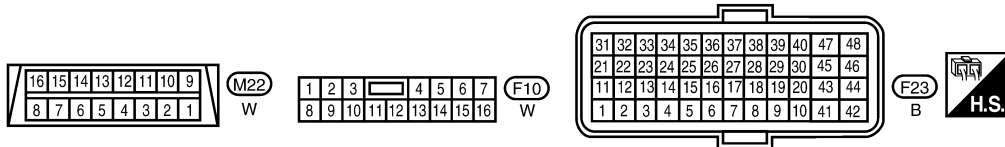
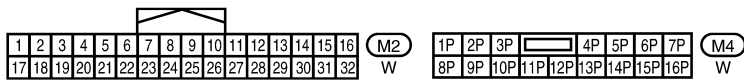
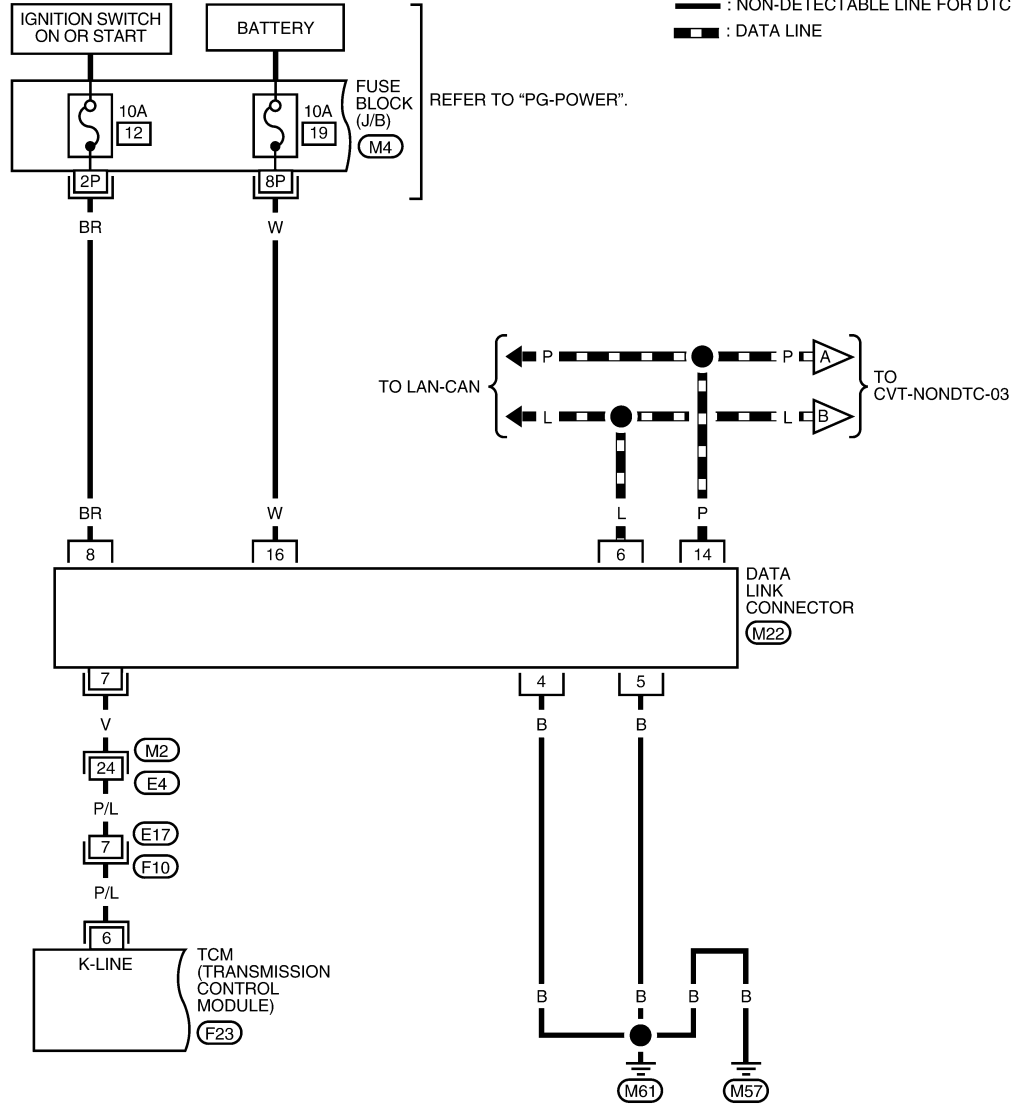

BCWA0750E

TROUBLE DIAGNOSIS FOR SYMPTOMS

< SERVICE INFORMATION >

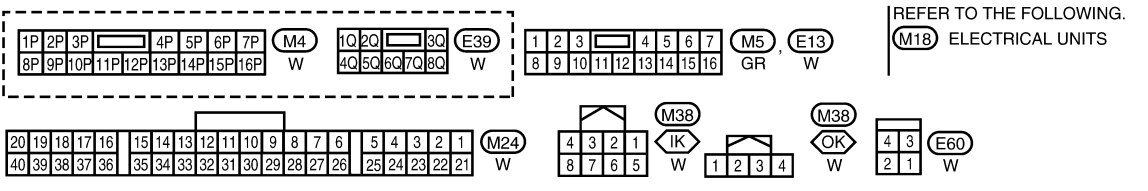
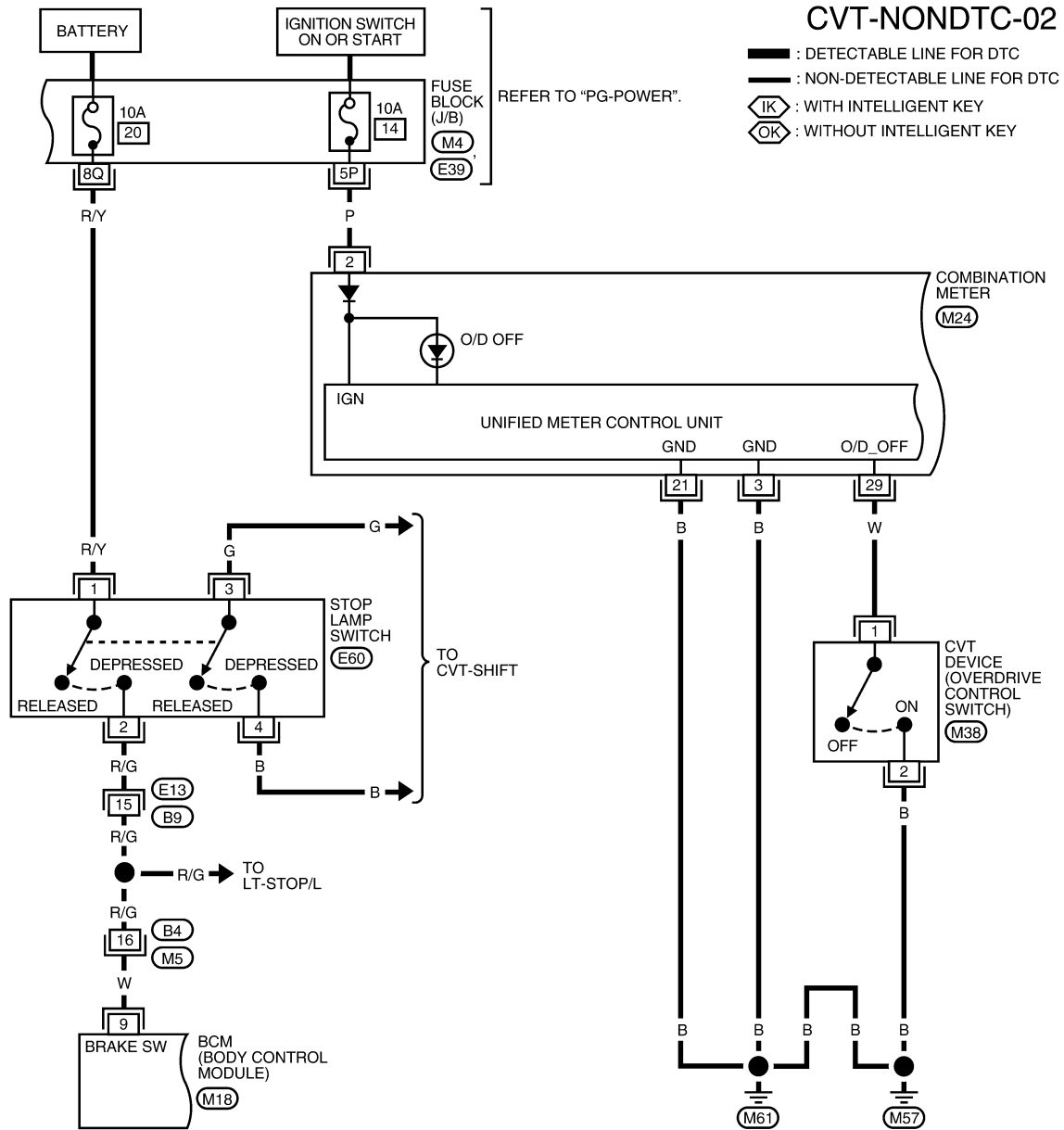

BCWA0751E

TROUBLE DIAGNOSIS FOR SYMPTOMS

< SERVICE INFORMATION >

CVT-NONDTC-03

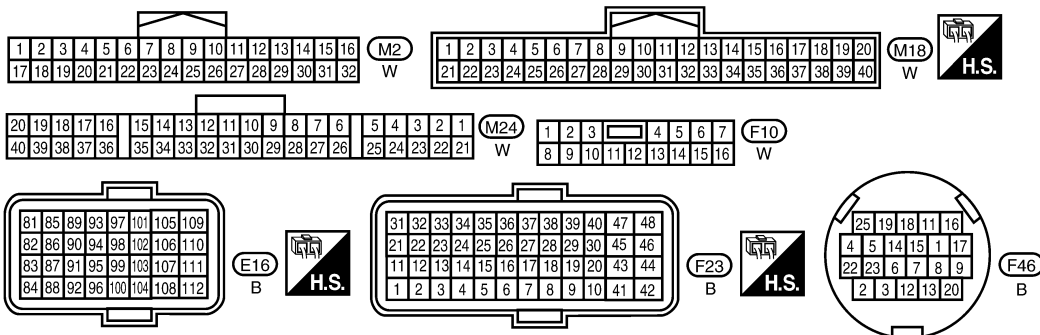
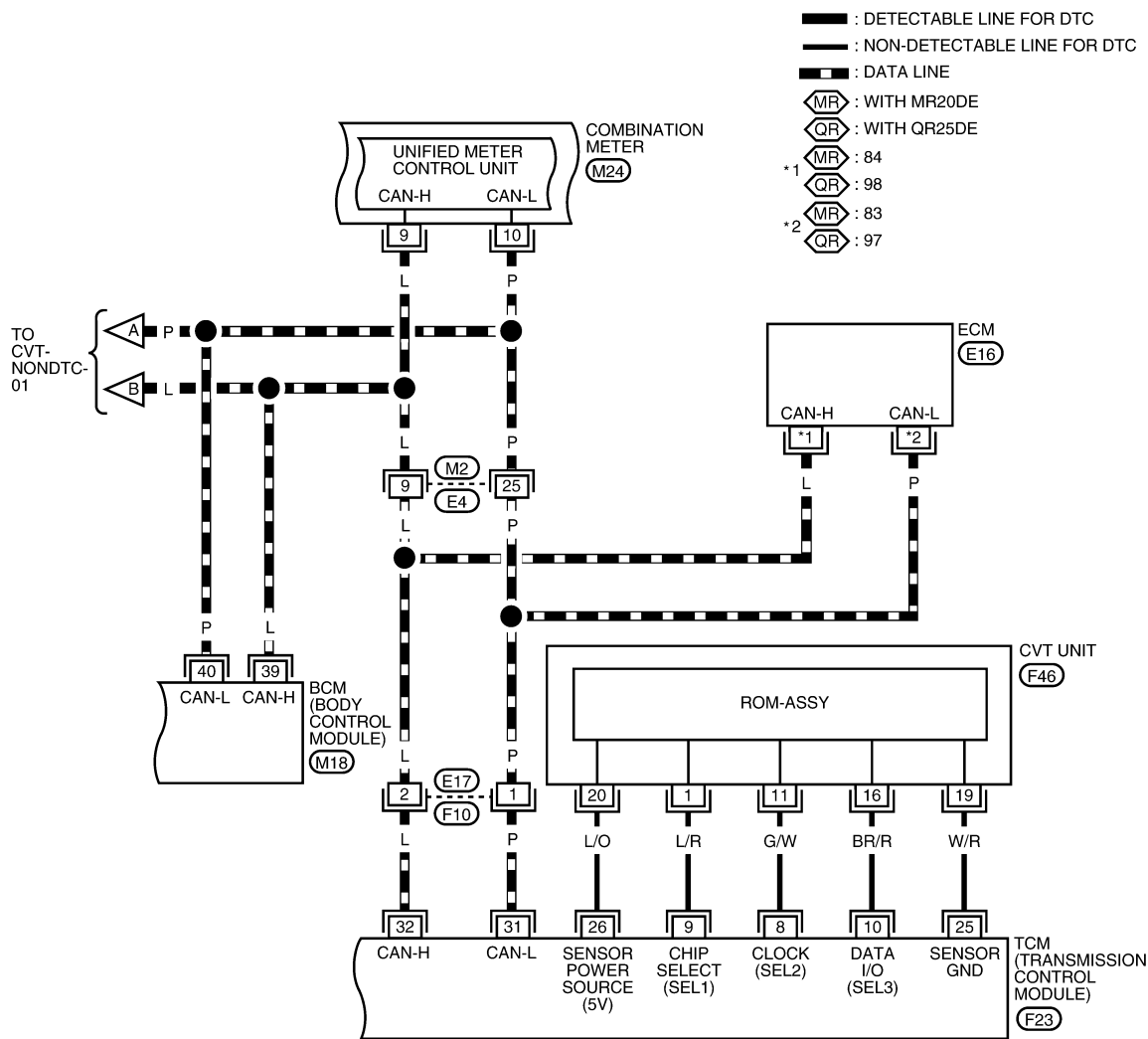

BCWA0752E

TROUBLE DIAGNOSIS FOR SYMPTOMS

< SERVICE INFORMATION >

CVT-NONDTC-04

- : DETECTABLE LINE FOR DTC
- - -** : NON-DETECTABLE LINE FOR DTC
- QR** : WITH QR25DE

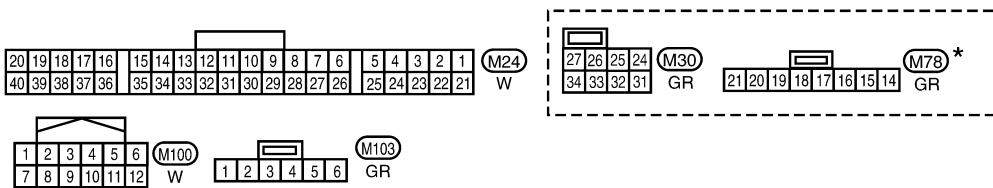
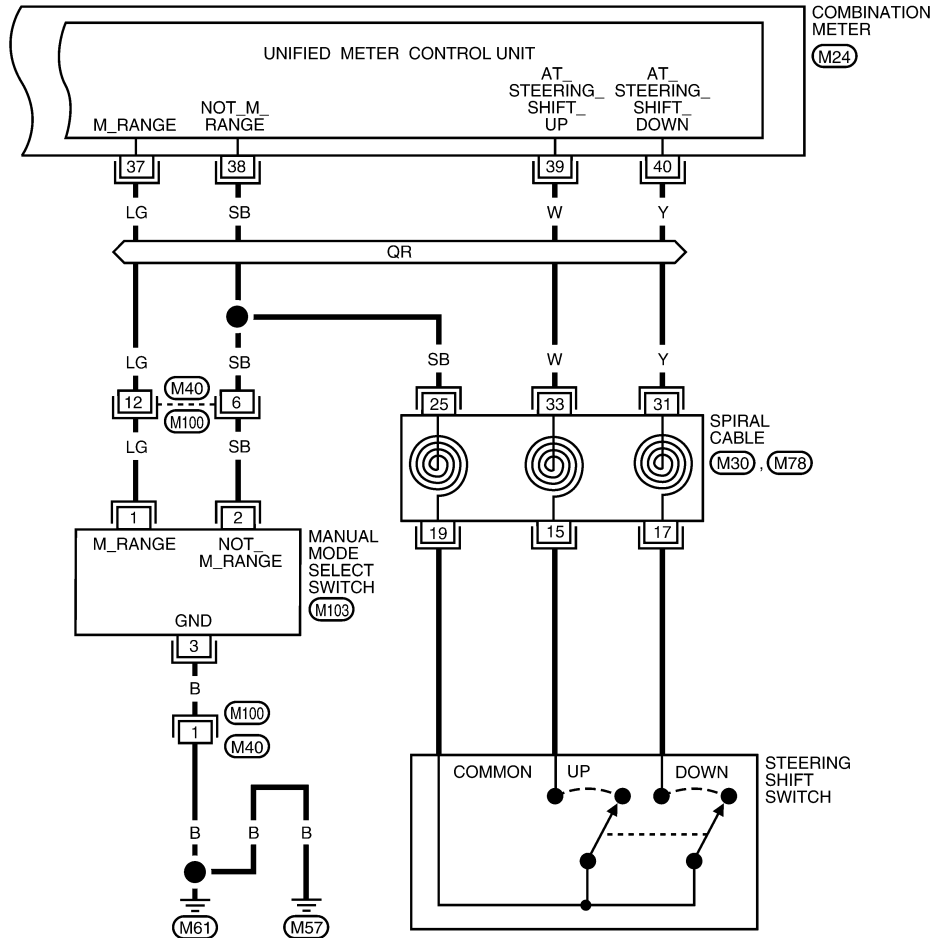

* : THIS CONNECTOR IS NOT SHOWN IN "HARNESS LAYOUT" OF PG SECTION.

AWDWA0008G

TCM TERMINALS AND REFERENCE VALUES

Refer to [CVT-45, "TCM Input/Output Signal Reference Value"](#).

O/D OFF Indicator Lamp Does Not Come On

INFOID:000000004407280

SYMPTOM:

CVT-150

TROUBLE DIAGNOSIS FOR SYMPTOMS

< SERVICE INFORMATION >

O/D OFF indicator lamp does not come on for about 2 seconds when turning ignition switch ON.

DIAGNOSTIC PROCEDURE

1. CHECK CAN COMMUNICATION LINE

Perform the self-diagnosis check. Refer to [CVT-47, "CONSULT-III Function \(TRANSMISSION\)"](#).

Is any malfunction of the "U1000 CAN COMM CIRCUIT" indicated in the results?

YES >> Check CAN communication line. Refer to [CVT-55](#).

NO >> GO TO 2.

2. CHECK TCM POWER SOURCE

1. Turn ignition switch ON.
2. Check voltage between TCM connector terminals and ground. Refer to [CVT-119, "Wiring Diagram - CVT - POWER"](#).

Name	Connector	Terminal	Voltage (Approx.)
Power supply	F23	46 - Ground	Battery voltage
		48 - Ground	

OK or NG

OK >> GO TO 4.

NG >> GO TO 3.

3. DETECT MALFUNCTIONING ITEM

Check the following.

- Harness for short or open between ignition switch and TCM connector terminal 46, 48
Refer to [CVT-119, "Wiring Diagram - CVT - POWER"](#).
- 10 A fuse (No.49, located in the IPDM E/R). Refer to [CVT-119, "Wiring Diagram - CVT - POWER"](#).
- Ignition switch. Refer to [PG-3](#).

OK or NG

OK >> GO TO 4.

NG >> Repair or replace damaged parts.

4. CHECK TCM GROUND CIRCUIT

1. Turn ignition switch OFF.
2. Disconnect TCM connector (A).
3. Check continuity between TCM connector (A) terminals and ground. Refer to [CVT-119, "Wiring Diagram - CVT - POWER"](#).

Name	Connector	Terminal	Continuity
Ground	F23	5 - Ground	Yes
		42 - Ground	

OK or NG

OK >> GO TO 5.

NG >> Repair open circuit or short to ground or short to power in harness or connectors.

5. DETECT MALFUNCTIONING ITEM

Check the following.

- Harness and fuse for short or open between ignition switch and O/D OFF indicator lamp
Refer to [PG-3](#).

OK or NG

OK >> GO TO 6.

NG >> Repair or replace damaged parts.

6. CHECK SYMPTOM

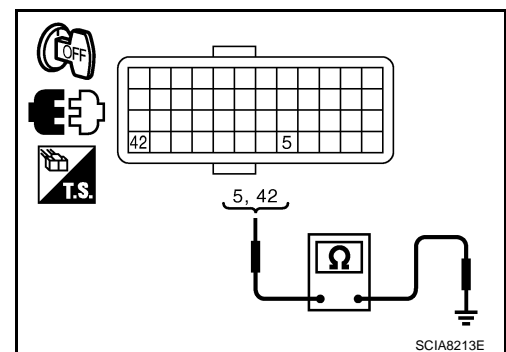

TROUBLE DIAGNOSIS FOR SYMPTOMS

< SERVICE INFORMATION >

Check again. Refer to [CVT-40, "Check before Engine Is Started"](#).

OK or NG

- OK >> **INSPECTION END**
- NG >> GO TO 7.

7.CHECK COMBINATION METERS

Check combination meters. Refer to [DI-5](#).

OK or NG

- OK >> **INSPECTION END**
- NG >> Repair or replace damaged parts.

Engine Cannot Be Started in "P" or "N" Position

INFOID:000000004407281

SYMPTOM:

- Engine cannot be started with selector lever in "P" or "N" position.
- Engine can be started with selector lever in "D", "L" or "R" position.

DIAGNOSTIC PROCEDURE

1.CHECK PNP SWITCH

Check continuity between PNP switch harness connector terminals. Refer to [CVT-35, "Circuit Diagram"](#).

Selector lever position	Connector	Terminal	Continuity
"P", "N"	F26	6 - 7	Yes
Other positions			No

OK or NG

- YES >> GO TO 3.
- NO >> GO TO 2.

2.CHECK CVT POSITION

Check CVT position. Refer to [CVT-170, "Checking of CVT Position"](#).

OK or NG

- OK >> Adjust CVT position. Refer to [CVT-170, "Adjustment of CVT Position"](#).
- NG >> Check PNP switch (Refer to test group 1.) again after adjusting PNP switch (Refer to [CVT-171](#)).
 - If OK, **INSPECTION END**
 - If NG, repair or replace PNP switch. Refer to [CVT-182, "Park/Neutral Position \(PNP\) Switch"](#).

3.CHECK STARTING SYSTEM

Check starting system. Refer to [SC-8](#).

OK or NG

- OK >> **INSPECTION END**
- NG >> Repair or replace damaged parts.

In "P" Position, Vehicle Moves Forward or Backward When Pushed

INFOID:000000004407282

SYMPTOM:

Vehicle moves when it is pushed forward or backward with selector lever in "P" position.

DIAGNOSTIC PROCEDURE

1.CHECK CVT POSITION

Check CVT position. Refer to [CVT-170, "Checking of CVT Position"](#).

OK or NG

- OK >> GO TO 2.
- NG >> Adjust CVT position. Refer to [CVT-170, "Adjustment of CVT Position"](#).

2.CHECK SYMPTOM

Check again. Refer to [CVT-40, "Check at Idle"](#).

TROUBLE DIAGNOSIS FOR SYMPTOMS

< SERVICE INFORMATION >

OK or NG

OK >> **INSPECTION END**

NG >> Replace the transaxle assembly. Refer to [CVT-190, "Removal and Installation \(MR20DE\)"](#).

In "N" Position, Vehicle Moves

INFOID:000000004407283

SYMPTOM:

Vehicle moves forward or backward when selecting "N" position.

DIAGNOSTIC PROCEDURE

1. CHECK SELF-DIAGNOSTIC RESULTS

Perform self-diagnosis check. Refer to [CVT-47, "CONSULT-III Function \(TRANSMISSION\)"](#).

Do the self-diagnostic results indicate PNP switch circuit?

YES >> Check PNP switch circuit. Refer to [CVT-61](#).

NO >> GO TO 2.

2. CHECK CVT POSITION

Check CVT position. Refer to [CVT-170, "Checking of CVT Position"](#).

OK or NG

OK >> GO TO 3.

NG >> Adjust CVT position. Refer to [CVT-170, "Adjustment of CVT Position"](#).

3. CHECK CVT FLUID LEVEL

Check CVT fluid level. Refer to [CVT-15, "Checking CVT Fluid"](#).

OK or NG

OK >> GO TO 4.

NG >> Refill CVT fluid.

4. CHECK SYMPTOM

Check again. Refer to [CVT-40, "Check at Idle"](#).

OK or NG

OK >> **INSPECTION END**

NG >> GO TO 5.

5. CHECK TCM

1. Check TCM input/output signals. Refer to [CVT-45, "TCM Input/Output Signal Reference Value"](#).

2. If NG, re-check TCM pin terminals for damage or loose connection with harness connector.

OK or NG

OK >> Replace the transaxle assembly. Refer to [CVT-190, "Removal and Installation \(MR20DE\)"](#).

NG >> Repair or replace damaged parts.

Large Shock "N" → "R" Position

INFOID:000000004407284

SYMPTOM:

There is large shock when shifting from "N" to "R" position.

DIAGNOSTIC PROCEDURE

1. CHECK SELF-DIAGNOSTIC RESULTS

Perform self-diagnosis check. Refer to [CVT-47, "CONSULT-III Function \(TRANSMISSION\)"](#).

Is any malfunction detected by self-diagnosis?

YES >> Check the malfunctioning system. Refer to [CVT-47, "CONSULT-III Function \(TRANSMISSION\)"](#).

NO >> GO TO 2.

2. CHECK ENGINE IDLE SPEED

Check the engine idle speed. Refer to [EC-89, "Idle Speed and Ignition Timing Check"](#).

OK or NG

A

B

CVT

D

E

F

G

H

I

J

K

L

M

N

O

P

TROUBLE DIAGNOSIS FOR SYMPTOMS

< SERVICE INFORMATION >

- OK >> GO TO 3.
- NG >> Repair.

3.CHECK CVT FLUID LEVEL

Check CVT fluid level. Refer to [CVT-15, "Checking CVT Fluid"](#).

OK or NG

- OK >> GO TO 4.
- NG >> Refill CVT fluid.

4.CHECK LINE PRESSURE

Check line pressure at idle. Refer to [CVT-36, "Inspections before Trouble Diagnosis"](#).

OK or NG

- OK >> GO TO 5.
- NG >> Check the malfunctioning item. Refer to [CVT-36, "Inspections before Trouble Diagnosis"](#).

5.SYMPTOM CHECK

Check again. Refer to [CVT-40, "Check at Idle"](#).

OK or NG

- OK >> **INSPECTION END**
- NG >> GO TO 6.

6.CHECK TCM

1. Check TCM input/output signals. Refer to [CVT-45, "TCM Input/Output Signal Reference Value"](#).
2. If NG, re-check TCM pin terminals for damage or loose connection with harness connector.

OK or NG

- OK >> Replace the transaxle assembly. Refer to [CVT-190, "Removal and Installation \(MR20DE\)"](#).
- NG >> Repair or replace damaged parts.

Vehicle Does Not Creep Backward in "R" Position

INFOID:000000004407285

SYMPTOM:

Vehicle does not creep backward when selecting "R" position.

DIAGNOSTIC PROCEDURE

1.CHECK SELF-DIAGNOSTIC RESULTS

Perform self-diagnosis check. Refer to [CVT-47, "CONSULT-III Function \(TRANSMISSION\)"](#).

Is any malfunction detected by self-diagnosis

- YES >> Check the malfunctioning system. Refer to [CVT-47, "CONSULT-III Function \(TRANSMISSION\)"](#).
- NO >> GO TO 2.

2.CHECK CVT POSITION

Check CVT position. Refer to [CVT-170, "Checking of CVT Position"](#).

OK or NG

- OK >> GO TO 3.
- NG >> Adjust CVT position. Refer to [CVT-170, "Adjustment of CVT Position"](#).

3.CHECK CVT FLUID LEVEL

Check CVT fluid level. Refer to [CVT-15, "Checking CVT Fluid"](#).

OK or NG

- OK >> GO TO 4.
- NG >> Refill CVT fluid.

4.CHECK LINE PRESSURE

Check line pressure at idle. Refer to [CVT-36, "Inspections before Trouble Diagnosis"](#).

OK or NG

- OK >> GO TO 5.

TROUBLE DIAGNOSIS FOR SYMPTOMS

< SERVICE INFORMATION >

NG >> Check the malfunctioning item. Refer to [CVT-36, "Inspections before Trouble Diagnosis"](#).

5.CHECK STALL REVOLUTION

Check stall revolution. Refer to [CVT-36, "Inspections before Trouble Diagnosis"](#).

OK or NG

OK >> GO TO 6.

NG >> Check the malfunctioning item. Refer to [CVT-36, "Inspections before Trouble Diagnosis"](#).

6.CHECK SYMPTOM

Check again. Refer to [CVT-40, "Check at Idle"](#).

OK or NG

OK >> **INSPECTION END**

NG >> GO TO 7.

7.CHECK TCM

1. Check TCM input/output signals. Refer to [CVT-45, "TCM Input/Output Signal Reference Value"](#).

2. If NG, re-check TCM pin terminals for damage or loose connection with harness connector.

OK or NG

OK >> Replace the transaxle assembly. Refer to [CVT-190, "Removal and Installation \(MR20DE\)"](#).

NG >> Repair or replace damaged parts.

Vehicle Does Not Creep Forward in "D" or "L" Position

INFOID:000000004407286

SYMPTOM:

Vehicle does not creep forward when selecting "D" or "L" position.

DIAGNOSTIC PROCEDURE

1.CHECK SELF-DIAGNOSTIC RESULTS

Perform self-diagnosis check. Refer to [CVT-47, "CONSULT-III Function \(TRANSMISSION\)"](#).

Is any malfunction detected by self-diagnosis?

YES >> Check the malfunctioning system. Refer to [CVT-47, "CONSULT-III Function \(TRANSMISSION\)"](#).

NO >> GO TO 2.

2.CHECK CVT POSITION

Check CVT position. Refer to [CVT-170, "Checking of CVT Position"](#).

OK or NG

OK >> GO TO 3.

NG >> Adjust CVT position. Refer to [CVT-170, "Adjustment of CVT Position"](#).

3.CHECK CVT FLUID LEVEL

Check CVT fluid level. Refer to [CVT-15, "Checking CVT Fluid"](#).

OK or NG

OK >> GO TO 4.

NG >> Refill CVT fluid.

4.CHECK LINE PRESSURE

Check line pressure at idle. Refer to [CVT-36, "Inspections before Trouble Diagnosis"](#).

OK or NG

OK >> GO TO 5.

NG >> Check the malfunctioning item. Refer to [CVT-36, "Inspections before Trouble Diagnosis"](#).

5.CHECK STALL REVOLUTION

Check stall revolution. Refer to [CVT-36, "Inspections before Trouble Diagnosis"](#).

OK or NG

OK >> GO TO 6.

NG >> Check the malfunctioning item. Refer to [CVT-36, "Inspections before Trouble Diagnosis"](#).

TROUBLE DIAGNOSIS FOR SYMPTOMS

< SERVICE INFORMATION >

6.CHECK SYMPTOM

Check again. Refer to [CVT-40, "Check at Idle"](#).

OK or NG

OK >> **INSPECTION END**

NG >> GO TO 7.

7.CHECK TCM

1. Check TCM input/output signals. Refer to [CVT-45, "TCM Input/Output Signal Reference Value"](#).

2. If NG, re-check TCM pin terminals for damage or loose connection with harness connector.

OK or NG

OK >> Replace the transaxle assembly. Refer to [CVT-190, "Removal and Installation \(MR20DE\)"](#).

NG >> Repair or replace damaged parts.

Vehicle Speed Does Not Change in "L" Position

INFOID:000000004407287

SYMPTOM:

Vehicle speed does not change in "L" position while the cruise test.

DIAGNOSTIC PROCEDURE

1.CHECK SELF-DIAGNOSTIC RESULTS

Perform self-diagnosis check. Refer to [CVT-47, "CONSULT-III Function \(TRANSMISSION\)"](#).

Is any malfunction detected by self-diagnosis?

YES >> Check the malfunctioning system. Refer to [CVT-47, "CONSULT-III Function \(TRANSMISSION\)"](#).

NO >> GO TO 2.

2.CHECK CVT POSITION

Check CVT position. Refer to [CVT-170, "Checking of CVT Position"](#).

OK or NG

OK >> GO TO 3.

NG >> Adjust CVT position. Refer to [CVT-170, "Adjustment of CVT Position"](#).

3.CHECK CVT FLUID LEVEL

Check CVT fluid level. Refer to [CVT-15, "Checking CVT Fluid"](#).

OK or NG

OK >> GO TO 4.

NG >> Refill CVT fluid.

4.CHECK LINE PRESSURE

Check line pressure at idle. Refer to [CVT-36, "Inspections before Trouble Diagnosis"](#).

OK or NG

OK >> GO TO 5.

NG >> Check the malfunctioning item. Refer to [CVT-36, "Inspections before Trouble Diagnosis"](#).

5.CHECK STALL REVOLUTION

Check stall revolution. Refer to [CVT-36, "Inspections before Trouble Diagnosis"](#).

OK or NG

OK >> GO TO 6.

NG >> Check the malfunctioning item. Refer to [CVT-36, "Inspections before Trouble Diagnosis"](#).

6.CHECK SYMPTOM

Check again. Refer to [CVT-41, "Cruise Test"](#).

OK or NG

OK >> **INSPECTION END**

NG >> GO TO 7.

TROUBLE DIAGNOSIS FOR SYMPTOMS

< SERVICE INFORMATION >

7.CHECK TCM

1. Check TCM input/output signals. Refer to [CVT-45, "TCM Input/Output Signal Reference Value"](#).
2. If NG, re-check TCM pin terminals for damage or loose connection with harness connector.

OK or NG

- OK >> Replace the transaxle assembly. Refer to [CVT-190, "Removal and Installation \(MR20DE\)"](#).
- NG >> Repair or replace damaged parts.

Vehicle Speed Does Not Change in overdrive-off mode

INFOID:000000004407288

CVT

SYMPTOM:

Vehicle speed does not change in overdrive-off mode while the cruise test.

DIAGNOSTIC PROCEDURE

1.CHECK SELF-DIAGNOSTIC RESULTS

Perform self-diagnosis check. Refer to [CVT-47, "CONSULT-III Function \(TRANSMISSION\)"](#).

Is any malfunction detected by self-diagnosis?

- YES >> Check the malfunctioning system. Refer to [CVT-47, "CONSULT-III Function \(TRANSMISSION\)"](#).
- NO >> GO TO 2.

2.CHECK OVERDRIVE CONTROL SWITCH

Check overdrive control switch. Refer to [CVT-141](#).

OK or NG

- OK >> GO TO 3.
- NG >> Repair or replace damaged parts.

3.CHECK CVT FLUID LEVEL

Check CVT fluid level. Refer to [CVT-15, "Checking CVT Fluid"](#).

OK or NG

- OK >> GO TO 4.
- NG >> Refill CVT fluid.

4.CHECK LINE PRESSURE

Check line pressure at idle. Refer to [CVT-36, "Inspections before Trouble Diagnosis"](#).

OK or NG

- OK >> GO TO 5.
- NG >> Check the malfunctioning item. Refer to [CVT-36, "Inspections before Trouble Diagnosis"](#).

5.CHECK STALL REVOLUTION

Check stall revolution. Refer to [CVT-36, "Inspections before Trouble Diagnosis"](#).

OK or NG

- OK >> GO TO 6.
- NG >> Check the malfunctioning item. Refer to [CVT-36, "Inspections before Trouble Diagnosis"](#).

6.CHECK SYMPTOM

Check again. Refer to [CVT-41, "Cruise Test"](#).

OK or NG

- OK >> **INSPECTION END**
- NG >> GO TO 7.

7.CHECK TCM

1. Check TCM input/output signals. Refer to [CVT-45, "TCM Input/Output Signal Reference Value"](#).
2. If NG, re-check TCM pin terminals for damage or loose connection with harness connector.

OK or NG

- OK >> Replace the transaxle assembly. Refer to [CVT-190, "Removal and Installation \(MR20DE\)"](#).
- NG >> Repair or replace damaged parts.

TROUBLE DIAGNOSIS FOR SYMPTOMS

< SERVICE INFORMATION >

Vehicle Speed Does Not Change in "D" Position

INFOID:000000004407289

SYMPTOM:

Vehicle speed does not change in "D" position while the cruise test.

DIAGNOSTIC PROCEDURE

1.CHECK SELF-DIAGNOSTIC RESULTS

Perform self-diagnosis check. Refer to [CVT-47, "CONSULT-III Function \(TRANSMISSION\)".](#)

Is any malfunction detected by self-diagnosis?

YES >> Check the malfunctioning system. Refer to [CVT-47, "CONSULT-III Function \(TRANSMISSION\)".](#)

NO >> GO TO 2.

2.CHECK CVT POSITION

Check CVT position. Refer to [CVT-170, "Checking of CVT Position".](#)

OK or NG

OK >> GO TO 3.

NG >> Adjust CVT position. Refer to [CVT-170, "Adjustment of CVT Position".](#)

3.CHECK CVT FLUID LEVEL

Check CVT fluid level. Refer to [CVT-15, "Checking CVT Fluid".](#)

OK or NG

OK >> GO TO 4.

NG >> Refill CVT fluid.

4.CHECK LINE PRESSURE

Check line pressure at idle. Refer to [CVT-36, "Inspections before Trouble Diagnosis".](#)

OK or NG

OK >> GO TO 5.

NG >> Check the malfunctioning item. Refer to [CVT-36, "Inspections before Trouble Diagnosis".](#)

5.CHECK STALL REVOLUTION

Check stall revolution. Refer to [CVT-36, "Inspections before Trouble Diagnosis".](#)

OK or NG

OK >> GO TO 6.

NG >> Check the malfunctioning item. Refer to [CVT-36, "Inspections before Trouble Diagnosis".](#)

6.CHECK SYMPTOM

Check again. Refer to [CVT-41, "Cruise Test".](#)

OK or NG

OK >> **INSPECTION END**

NG >> GO TO 7.

7.CHECK TCM

1. Check TCM input/output signals. Refer to [CVT-45, "TCM Input/Output Signal Reference Value".](#)

2. If NG, re-check TCM pin terminals for damage or loose connection with harness connector.

OK or NG

OK >> Replace the transaxle assembly. Refer to [CVT-190, "Removal and Installation \(MR20DE\)".](#)

NG >> Repair or replace damaged parts.

Cannot Be Changed to Manual Mode

INFOID:000000004407290

SYMPTOM:

Does not change to manual mode when manual shift gate is used.

DIAGNOSTIC PROCEDURE

1.CHECK SELF-DIAGNOSTIC RESULTS

TROUBLE DIAGNOSIS FOR SYMPTOMS

< SERVICE INFORMATION >

Perform self-diagnosis check. Refer to [CVT-47, "CONSULT-III Function \(TRANSMISSION\)"](#) .

Is any malfunction detected by self-diagnosis?

- YES >> Check the malfunctioning system. Refer to [CVT-47, "CONSULT-III Function \(TRANSMISSION\)"](#) .
- NO >> GO TO 2.

2.CHECK MANUAL MODE SWITCH

Check the manual mode switch circuit. Refer to [CVT-105](#) .

OK or NG

- OK >> GO TO 3.
- NG >> Repair or replace damaged parts.

3.SYMPTOM CHECK

Check again. Refer to [CVT-41, "Cruise Test"](#) .

OK or NG

- OK >> **INSPECTION END**
- NG >> GO TO 4.

4.CHECK TCM

1. Check TCM input/output signals. Refer to [CVT-45, "TCM Input/Output Signal Reference Value"](#) .
2. If NG, re-check TCM pin terminals for damage or loose connection with harness connector.

OK or NG

- OK >> **INSPECTION END**
- NG >> Repair or replace damaged parts.

CVT Does Not Shift in Manual Mode

INFOID:000000004407291

SYMPTOM:

Speed does not change even if the selector lever is put in the manual shift gate position and the selector lever is operated to + side or to - side.

DIAGNOSTIC PROCEDURE

1.CHECK SELF-DIAGNOSTIC RESULTS

Perform self-diagnosis check. Refer to [CVT-47, "CONSULT-III Function \(TRANSMISSION\)"](#) .

Is any malfunction detected by self-diagnosis?

- YES >> Check the malfunctioning system. Refer to [CVT-47, "CONSULT-III Function \(TRANSMISSION\)"](#) .
- NO >> GO TO 2.

2.CHECK MANUAL MODE SWITCH

Check the manual mode switch circuit. Refer to [CVT-105](#) .

OK or NG

- OK >> GO TO 3.
- NG >> Repair or replace damaged parts.

3.CHECK CVT POSITION

Check CVT position. Refer to [CVT-170, "Checking of CVT Position"](#)

OK or NG

- OK >> GO TO 4.
- NG >> Adjust CVT position. Refer to [CVT-170, "Adjustment of CVT Position"](#).

4.CHECK CVT FLUID LEVEL

TROUBLE DIAGNOSIS FOR SYMPTOMS

< SERVICE INFORMATION >

Check CVT fluid level. Refer to [CVT-15. "Checking CVT Fluid"](#).

OK or NG

- OK >> GO TO 5.
- NG >> Refill CVT fluid.

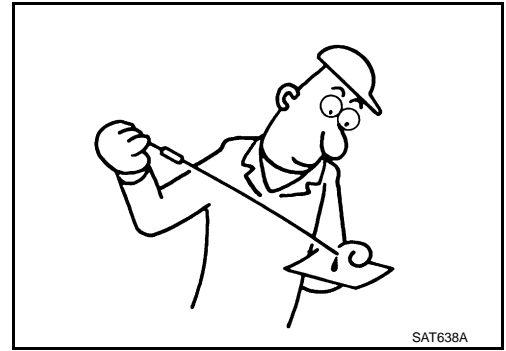

5.CHECK LINE PRESSURE

Check line pressure at idle. Refer to [CVT-36. "Inspections before Trouble Diagnosis"](#).

OK or NG

- OK >> GO TO 6.
- NG >> Check the malfunctioning item. Refer to [CVT-36. "Inspections before Trouble Diagnosis"](#).

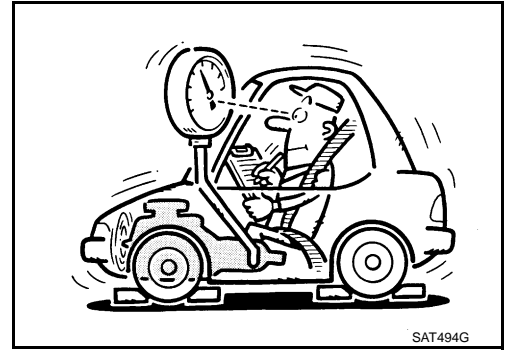

6.CHECK SYMPTOM

Check again. Refer to [CVT-41. "Cruise Test"](#).

OK or NG

- OK >> **INSPECTION END**
- NG >> GO TO 7.

7.CHECK TCM

1. Check TCM input/output signals. Refer to [CVT-45. "TCM Input/Output Signal Reference Value"](#).
2. If NG, re-check TCM pin terminals for damage or loose connection with harness connector.

OK or NG

- OK >> Replace the transaxle assembly. Refer to [CVT-190. "Removal and Installation \(MR20DE\)"](#) or [CVT-192. "Removal and Installation \(QR25DE\)"](#).
- NG >> Repair or replace damaged parts.

Vehicle Does Not Decelerate by Engine Brake

INFOID:000000004407292

SYMPTOM:

Engine brake does not operate when releasing the accelerator pedal while the cruise test.

DIAGNOSTIC PROCEDURE

1.CHECK SELF-DIAGNOSTIC RESULTS

Perform self-diagnosis check. Refer to [CVT-47. "CONSULT-III Function \(TRANSMISSION\)"](#).

Is any malfunction detected by self-diagnosis?

- YES >> Check the malfunctioning system. Refer to [CVT-47. "CONSULT-III Function \(TRANSMISSION\)"](#).
- NO >> GO TO 2.

2.CHECK CVT POSITION

Check CVT position. Refer to [CVT-170. "Checking of CVT Position"](#).

OK or NG

- OK >> GO TO 3.
- NG >> Adjust CVT position. Refer to [CVT-170. "Adjustment of CVT Position"](#).

3.CHECK CVT FLUID LEVEL

TROUBLE DIAGNOSIS FOR SYMPTOMS

< SERVICE INFORMATION >

Check CVT fluid level. Refer to [CVT-15, "Checking CVT Fluid"](#).

OK or NG

OK >> GO TO 4.

NG >> Refill CVT fluid.

4.CHECK LINE PRESSURE

Check line pressure at idle. Refer to [CVT-36, "Inspections before Trouble Diagnosis"](#).

OK or NG

OK >> GO TO 5.

NG >> Check the malfunctioning item. Refer to [CVT-36, "Inspections before Trouble Diagnosis"](#).

5.CHECK SYMPTOM

Check again. Refer to [CVT-41, "Cruise Test"](#).

OK or NG

OK >> **INSPECTION END**

NG >> GO TO 6.

6.CHECK TCM

1. Check TCM input/output signals. Refer to [CVT-45, "TCM Input/Output Signal Reference Value"](#).

2. If NG, re-check TCM pin terminals for damage or loose connection with harness connector.

OK or NG

OK >> Replace the transaxle assembly. Refer to [CVT-190, "Removal and Installation \(MR20DE\)"](#).

NG >> Repair or replace damaged parts.

A

B

CVT

D

E

F

G

H

I

J

K

L

M

N

O

P

TRANSMISSION CONTROL MODULE

< SERVICE INFORMATION >

TRANSMISSION CONTROL MODULE

Removal and Installation

INFOID:000000004407293

COMPONENTS

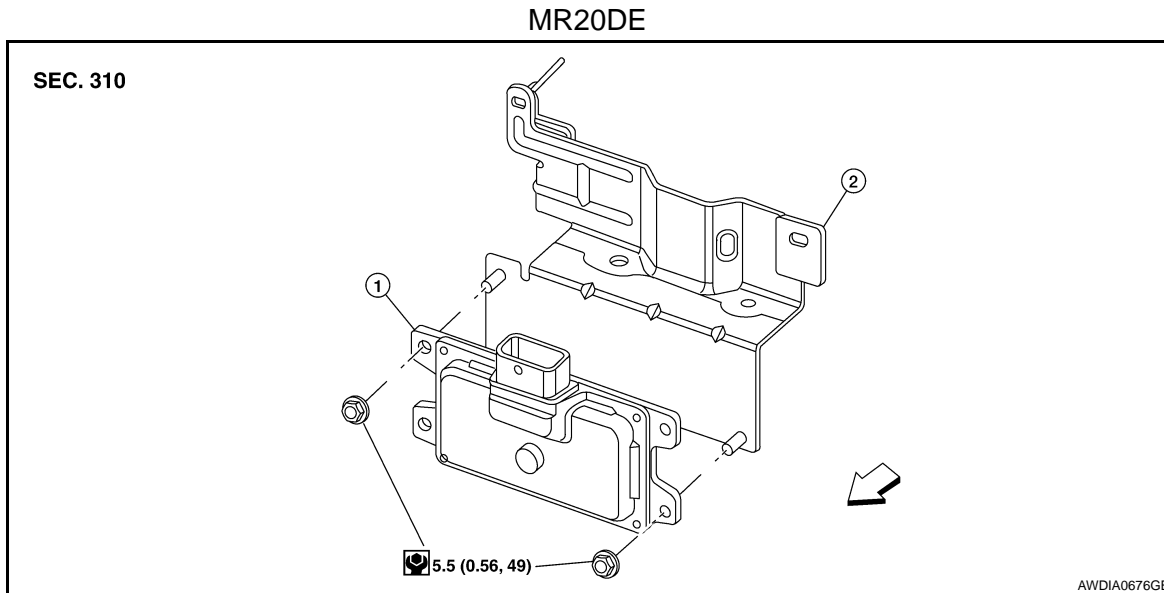

1. TCM

2. Bracket

← Front

REMOVAL

1. Disconnect the battery negative terminal.
2. Remove the fresh air intake tube (upper). Refer to [EM-16](#).
3. Disconnect the TCM harness connector.
4. Remove the TCM (1).

INSTALLATION

Installation is in the reverse order of removal.

COMPONENTS

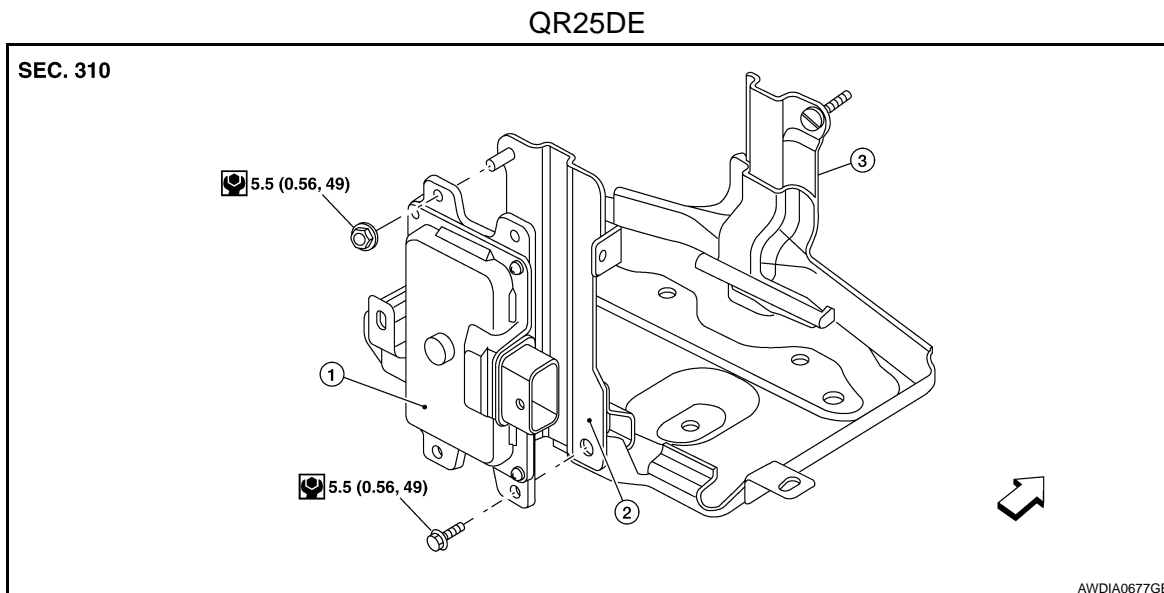

TRANSMISSION CONTROL MODULE

< SERVICE INFORMATION >

1. TCM

↶ Front

2. Bracket

3. Battery tray

A

REMOVAL

1. Disconnect the battery negative terminal.
2. Remove the air cleaner case. Refer to [EM-16](#).
3. Disconnect the TCM harness connector.
4. Remove the TCM.

B

CVT

INSTALLATION

Installation is in the reverse order of removal.

D

E

F

G

H

I

J

K

L

M

N

O

P

CVT SHIFT LOCK SYSTEM

< SERVICE INFORMATION >

CVT SHIFT LOCK SYSTEM

Description

INFOID:000000004407294

- The mechanical key interlock mechanism also operates as a shift lock:
With the ignition switch turned to ON, selector lever cannot be shifted from "P" position to any other position unless brake pedal is depressed.
With the key removed, selector lever cannot be shifted from "P" position to any other position.
The key cannot be removed unless selector lever is placed in "P" position.
- The shift lock and key interlock mechanisms are controlled by the ON-OFF operation of the shift lock solenoid and by the operation of the rotator and slider located inside key cylinder, respectively.

Shift Lock System Electrical Parts Location

INFOID:000000004407295

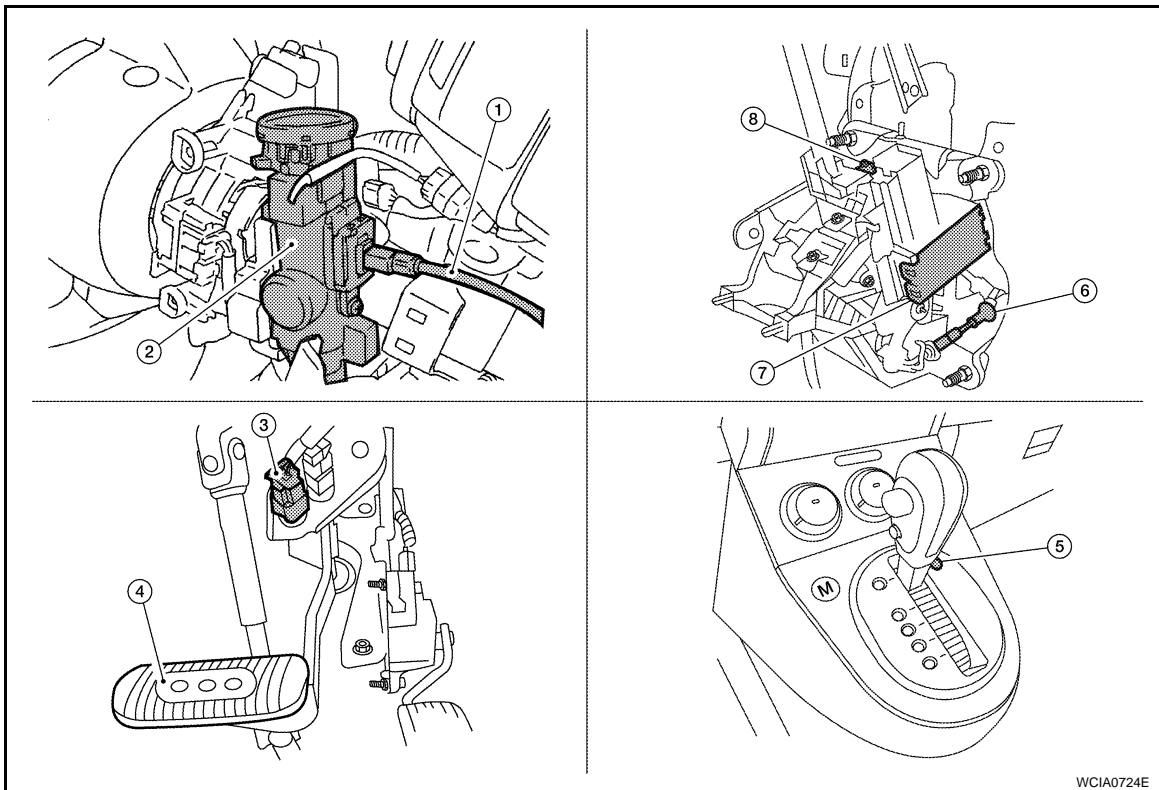

1. Key interlock cable
4. Brake pedal
7. Shift lock solenoid

2. Key cylinder
5. Shift lock release button
8. Park position switch

3. Stop lamp switch
6. Key interlock cable

CVT SHIFT LOCK SYSTEM

< SERVICE INFORMATION >

Wiring Diagram - CVT - SHIFT

INFOID:000000004407296

A
B
C
D
E
F
G
H
I
J
K
L
M
N
O
P

CVT

CVT-SHIFT-01

⬡IK : WITH INTELLIGENT KEY
⬡OK : WITHOUT INTELLIGENT KEY

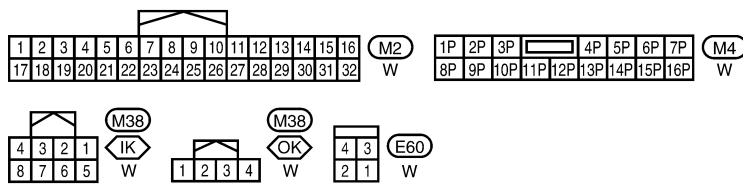
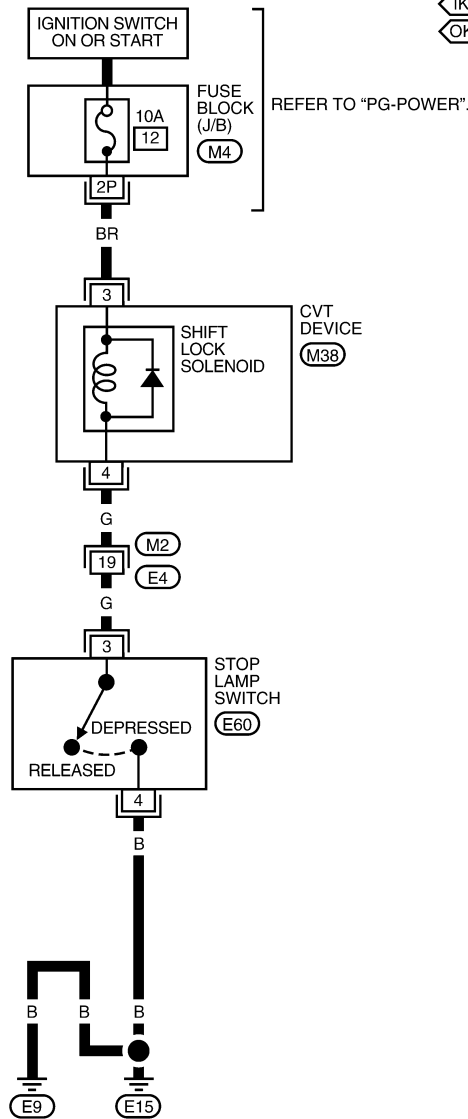

AWDWA0009G

INFOID:000000004407297

Diagnosis Procedure

SYMPTOM 1:

- Selector lever cannot be moved from "P" position with ignition switch in ON position and brake pedal depressed.

CVT SHIFT LOCK SYSTEM

< SERVICE INFORMATION >

- Selector lever can be moved from “P” position with ignition key in ON position and brake pedal released.
- Selector lever can be moved from “P” position when ignition switch is removed from key cylinder.

SYMPTOM 2:

- Ignition key cannot be removed when selector lever is set to “P” position.
- Ignition key can be removed when selector lever is set to any position except “P” position.
- Ignition switch (i-key) cannot be turned when selector lever is set to “P” position.
- Ignition switch (i-key) can be turned when selector lever is set to any position except “P” position.

1. CHECK KEY INTERLOCK CABLE

Check key interlock cable for damage.

OK or NG

OK >> GO TO 2.

NG >> Repair key interlock cable. Refer to [CVT-172. "Removal and Installation"](#).

2. CHECK CVT POSITION

Check CVT position. Refer to [CVT-170. "Checking of CVT Position"](#).

OK or NG

OK >> GO TO 3.

NG >> Adjust control cable. Refer to [CVT-170. "Adjustment of CVT Position"](#).

3. CHECK SHIFT LOCK SOLENOID AND PARK POSITION SWITCH

1. Turn ignition switch ON. (Do not start engine.)
2. Selector lever is set in “P” position.
3. Check operation sound.

Condition	Brake pedal	Operation sound
When ignition switch is turned to ON position and selector lever is set in “P” position.	Depressed	Yes
	Released	No

OK or NG

OK >> **INSPECTION END**

NG >> GO TO 4.

4. CHECK POWER SOURCE

Check voltage between CVT device harness connector M38 terminal 3 and ground.

OK or NG

OK >> GO TO 6.

NG >> GO TO 5.

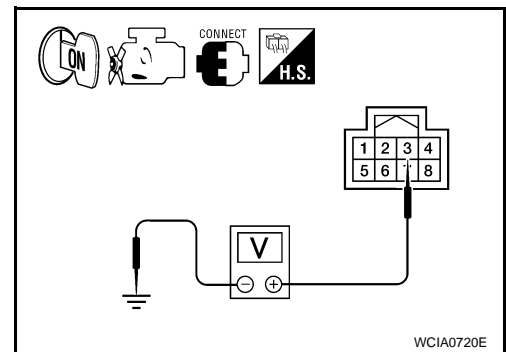

5. DETECT MALFUNCTIONING ITEM

Check the following. If any items are damaged, repair or replace damaged parts.

- Harness for short or open between ignition switch and CVT device harness connector
- 10A fuse [No.12, located in the fuse block (J/B)]
- Ignition switch, Refer to [PG-3](#) .

OK or NG

OK >> **INSPECTION END**

NG >> Repair or replace damaged parts.

6. CHECK STOP LAMP SWITCH POWER SOURCE

CVT SHIFT LOCK SYSTEM

< SERVICE INFORMATION >

1. Turn ignition switch OFF.
2. Disconnect stop lamp switch harness connector M38.
3. Turn ignition switch ON.
4. Check voltage between stop lamp switch harness connector E60 terminal 3 and ground.

3 - ground : Battery voltage

OK or NG

- OK >> GO TO 8.
NG >> GO TO 7.

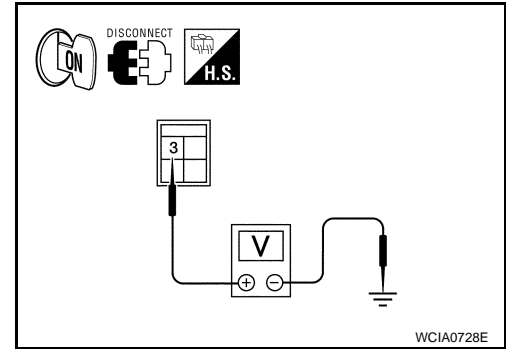

7. CHECK STOP LAMP SWITCH SUPPLY CIRCUIT

1. Turn ignition switch OFF.
2. Disconnect CVT device harness connector E60.
3. Check continuity between stop lamp switch harness connector E60 (B) terminal 3 and CVT device harness connector M38 (A) terminal 4.

Continuity should exist.

OK or NG

- OK >> Replace shift lock solenoid assembly.
NG >> Repair or replace harness as necessary.

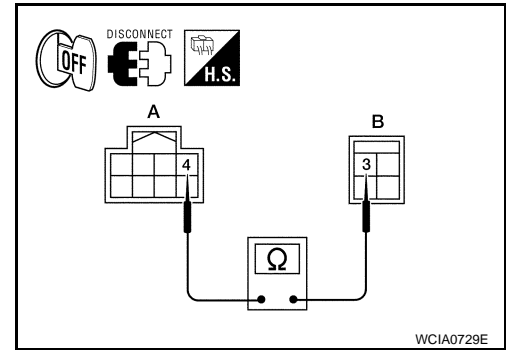

8. CHECK GROUND CIRCUIT

1. Turn ignition switch OFF.
2. Check continuity between stop lamp switch harness connector E60 terminal 4 and ground.

Continuity should exist.

OK or NG

- OK >> GO TO 9.
NG >> Repair or replace harness as necessary.

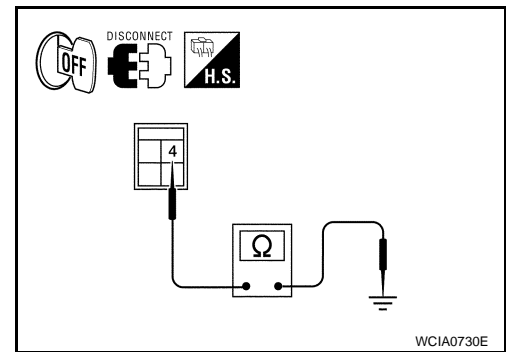

9. CHECK STOP LAMP SWITCH

Check continuity between stop lamp switch harness connector terminals 3 and 4.

Condition	Continuity
When brake pedal is depressed	Yes
When brake pedal is released	No

Check stop lamp switch after adjusting brake pedal. Refer to BR-5.

OK or NG

- OK >> **INSPECTION END.**
NG >> Replace stop lamp switch.

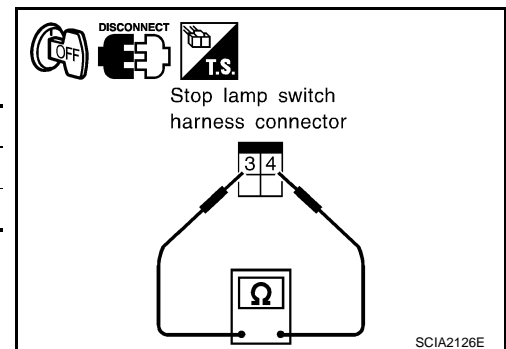

A
B
CVT
D
E
F
G
H
I
J
K
L
M
N
O
P

SHIFT CONTROL SYSTEM

< SERVICE INFORMATION >

SHIFT CONTROL SYSTEM

Removal and Installation

INFOID:000000004407298

CONTROL DEVICE COMPONENTS

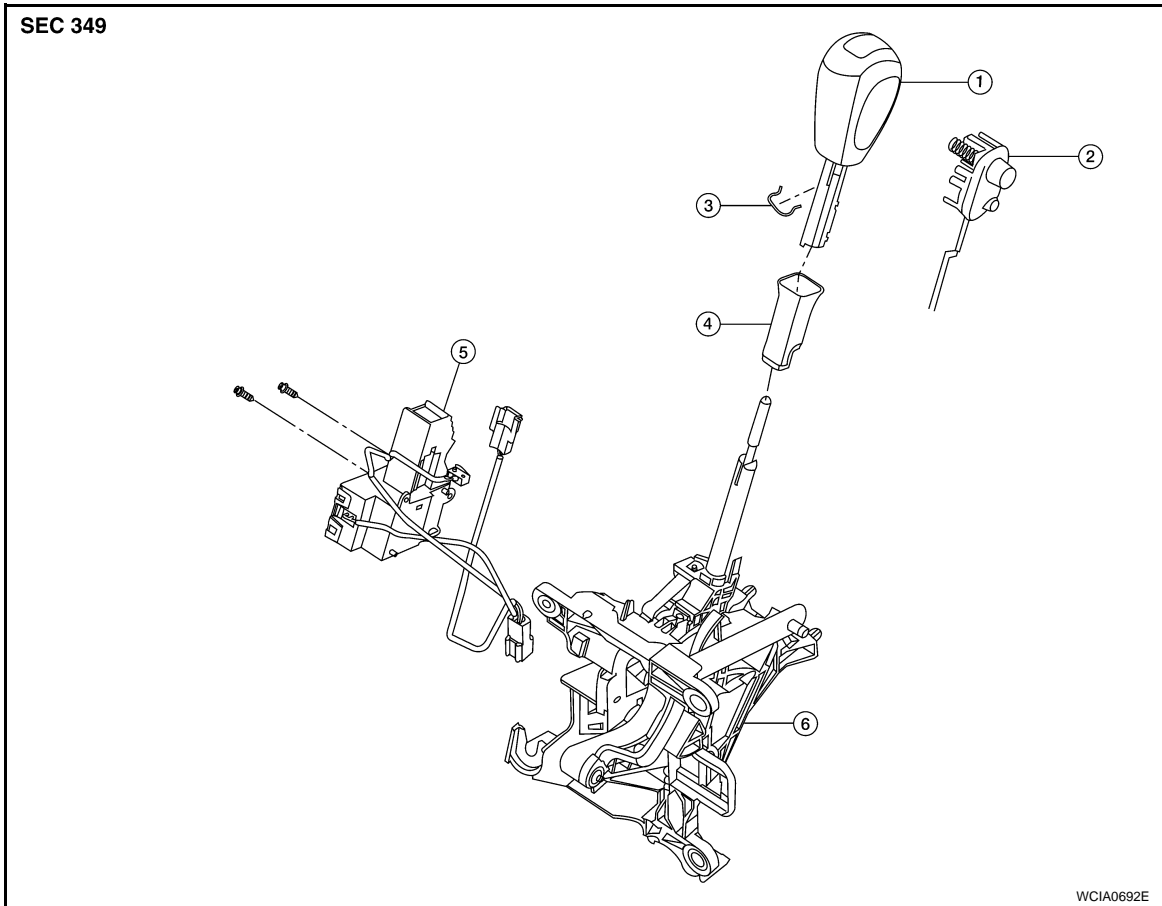

- | | | |
|------------------------|--|--|
| 1. Selector lever knob | 2. Selector button and overdrive connector switch assembly | 3. Lock pin |
| 4. Knob cover | 5. Shift lock solenoid and park position switch assembly | 6. Control device assembly switch assembly |

CONTROL CABLE COMPONENTS

SHIFT CONTROL SYSTEM

< SERVICE INFORMATION >

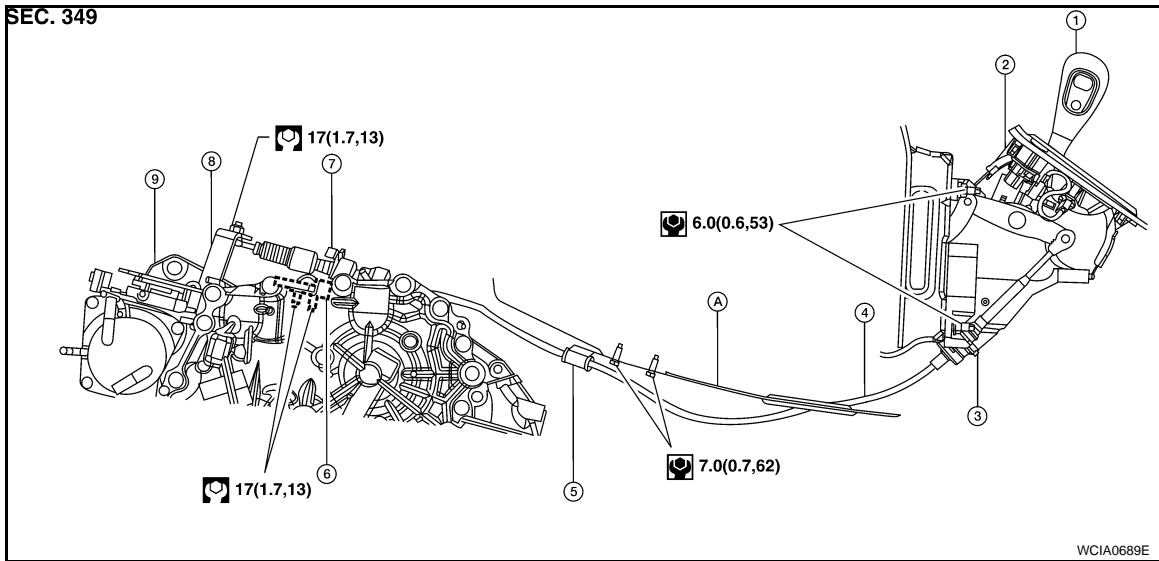

- | | | |
|------------------------|----------------------------|-----------------------|
| 1. Selector lever knob | 2. Control device assembly | 3. Cable socket |
| 4. Control cable | 5. Cable bracket | 6. Bracket |
| 7. Lock plate | 8. Manual lever | 9. Transaxle assembly |
| A. Floor | | |

REMOVAL

CAUTION:

Make sure that parking brake is applied before removal and installation.

- Place the selector lever in the "P" position.
- Remove the IP center assembly. Refer to [IP-11](#).
- Disconnect the CVT device harness connector.
- Remove the key interlock cable from the control device assembly. Refer to [CVT-172. "Removal and Installation"](#).
- Remove the control cable from the control device assembly.
- Remove the nuts and the control device assembly.

INSTALLATION

Installation is in the reverse order of removal.

- When installing the control cable (3) to the control device assembly (2), make sure that the control cable socket is fully pressed into the control device assembly (2), and the control cable end (1) is fully pressed in with the ribbed surface (A) facing towards the front of the vehicle.

⇐: Vehicle front

- After installation is completed, adjust and check the CVT position. Refer to [CVT-170. "Adjustment of CVT Position"](#) and [CVT-170. "Checking of CVT Position"](#).

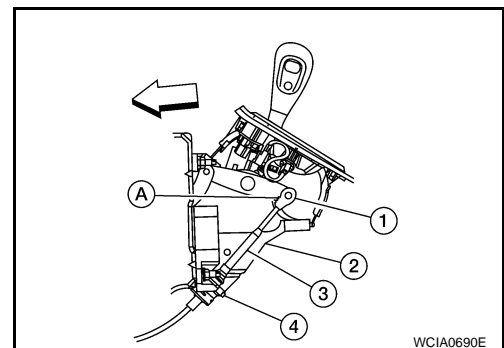

Selector Lever Knob Removal and Installation

INFOID:000000004407299

REMOVAL

CAUTION:

Make sure that parking brake is applied before removal and installation.

SHIFT CONTROL SYSTEM

< SERVICE INFORMATION >

1. Set selector lever knob (1) in "N" position.
2. Slide knob cover (2) downward.
3. Pull out lock pin (3) from selector lever knob (1).
4. Remove selector lever knob (1) and knob cover (2) as a set from selector lever.

CAUTION:

Do not push selector button.

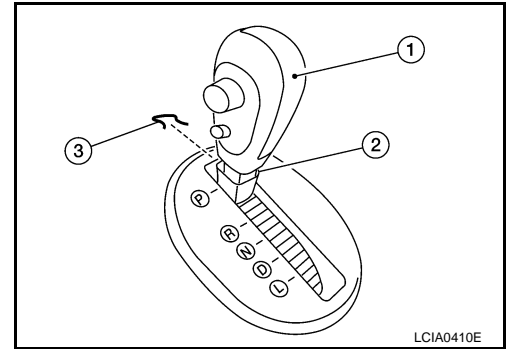

INSTALLATION

1. Insert lock pin (3) to selector lever knob (1).
2. Install knob cover (2) to selector lever knob (1).
3. Set selector lever in "N" position.
4. Install selector lever knob over selector lever until a click is felt.

CAUTION:

- Do not tilt selector lever knob when installing. Install it straight, and do not tap or apply any shock to install it.
- Do not push selector button.

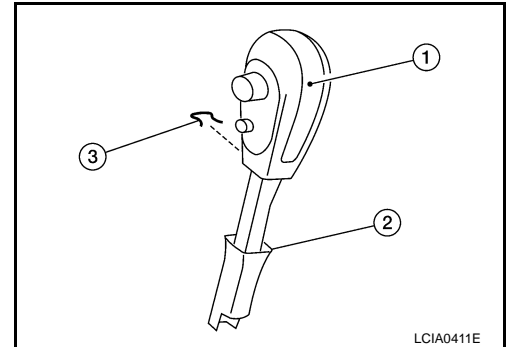

Adjustment of CVT Position

INFOID:000000004407300

CAUTION:

Make sure that parking brake is applied before adjustment.

1. Loosen the control cable nut and place the manual lever in "P" position.
2. Place selector lever in "P" position.
3. Temporarily tighten the control cable nut.

NOTE:

Do not move the manual lever. Make sure the manual lever stays in the "P" position.

4. Tighten the control cable nut.

Control cable nut: Refer to [CVT-168. "Removal and Installation"](#).

CAUTION:

Secure the manual lever when tightening nut.

5. Check the operation of the CVT. Refer to [CVT-170. "Checking of CVT Position"](#).

Checking of CVT Position

INFOID:000000004407301

1. Place selector lever in "P" position, and turn ignition switch ON. (Do not start engine.)
2. Make sure selector lever can be shifted to other than "P" position when brake pedal is depressed. Also make sure selector lever can be shifted from "P" position only when brake pedal is depressed.
3. Move the selector lever and check for excessive effort, sticking, noise or rattle.
4. Confirm the selector lever stops at each position with the feel of engagement when it is moved through all the positions. Check that the actual position of the selector lever matches the position shown by the shift position indicator and the manual lever on the transaxle.

SHIFT CONTROL SYSTEM

< SERVICE INFORMATION >

- The method of operating the selector lever to individual positions correctly should be as shown.
 - (A): Press selector button to operate selector lever, while depressing the brake pedal.
 - (B): Press selector button to operate selector lever.
 - (C): Selector lever can be operated without pressing selector button.
- Confirm the back-up lamps illuminate only when selector lever is placed in the "R" position. Confirm the back-up lamps do not illuminate when the selector lever is pushed toward the "R" position side with the gear position remained in the "P" or "N" position.
- Confirm the engine can only be started with the selector lever in the "P" and "N" positions.
- Make sure transaxle is locked completely in "P" position.

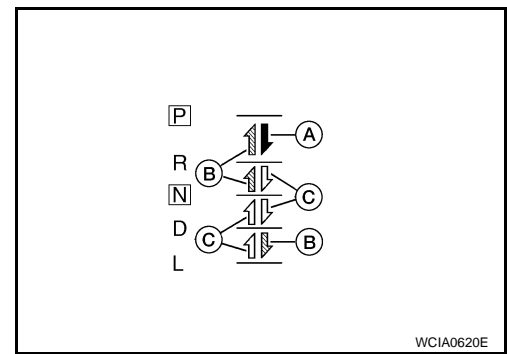

Adjustment of PNP switch

INFOID:000000004407302

- Move selector lever to "N" position.
- Remove control cable from manual lever.
- Loosen PNP switch bolts (A). Insert a pin ($\varnothing 4$ mm) into the adjusting holes (B) on both PNP switch and manual lever for adjusting the position.
- Tighten PNP switch bolts (A).

PNP switch bolts : 5.9 N·m (0.60 kg·m, 52 in·lb)

- Connect control cable on manual lever (B). Refer to [CVT-170, "Adjustment of CVT Position"](#).

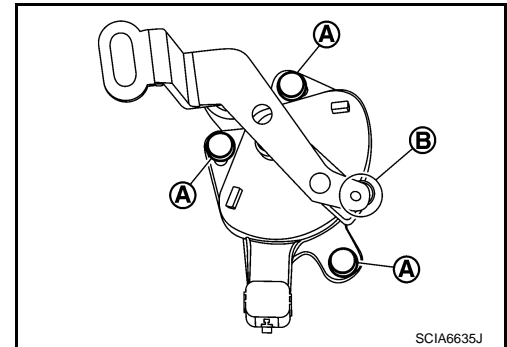

KEY INTERLOCK CABLE

< SERVICE INFORMATION >

KEY INTERLOCK CABLE

Removal and Installation

INFOID:000000004407303

COMPONENTS

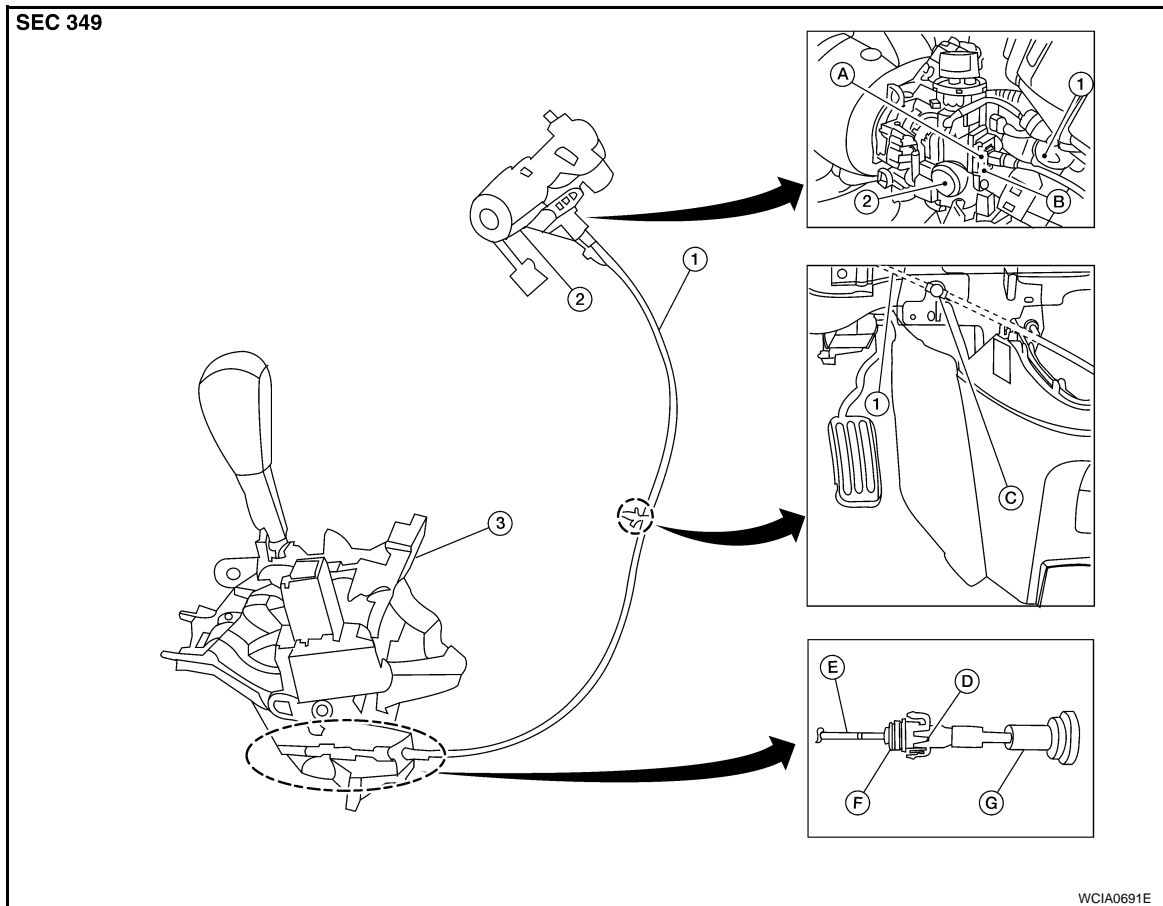

- | | | |
|------------------------|----------------------|----------------------------|
| 1. Key interlock cable | 2. Key cylinder | 3. Control device assembly |
| A. Lock plate | B. Holder | C. Clip |
| D. Slider | E. Key interlock rod | F. Adjust holder |
| G. Casing cap | | |

REMOVAL

Refer to the figure for key interlock cable removal procedure.

CAUTION:

Make sure that parking brake is applied before removal/installation.

1. Place the selector lever in the "N" position.
2. Remove the selector lever knob. Refer to [CVT-169, "Selector Lever Knob Removal and Installation"](#).
3. Remove the IP center assembly. Refer to [IP-11](#).

KEY INTERLOCK CABLE

< SERVICE INFORMATION >

- Slide the slider (A) toward the casing cap (B) while pressing tabs (C) on the slider to separate the slider (A) from the adjust holder (D).
- Remove the casing cap (B) from the cable bracket on the control device assembly.
- Remove the key interlock cable from the key interlock rod (E).

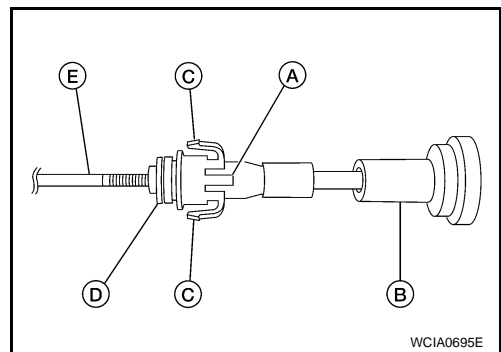

- Remove steering column cover (upper and lower) and instrument lower finisher. Refer to [IP-11](#).
- Pull out the lock plate (A) from the holder (B).
- Remove the key interlock cable (1) from the key cylinder (2).

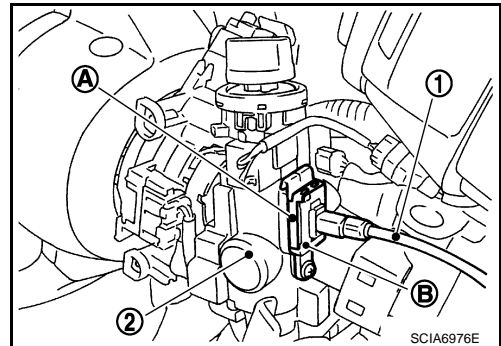

- Remove the clip and then remove the key interlock cable from the vehicle.

INSTALLATION

CAUTION:

- Install key interlock cable in such a way that it will not be damaged by sharp bends, twists or interference with adjacent parts.
- After installing key interlock cable to control device assembly, make sure that casing cap and bracket are firmly secured in their positions.

- Place the selector lever in the "P" position.
- Turn ignition switch to "ACC" or "ON" position.
- Set the key interlock cable (1) to the key cylinder (2).
- Install the lock plate (A) to the holder (B).
- Turn ignition switch to "LOCK" position.

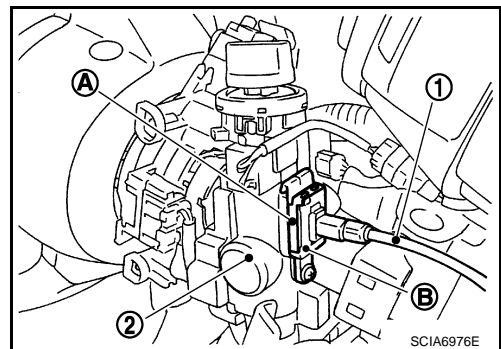

- Temporarily install the adjust holder (A) to the key interlock rod (B).
- Install the casing cap (C) to the cable bracket (D) on the control device assembly.

CAUTION:

- Do not bend or twist key interlock cable excessively when installing.
- After installing key interlock cable to cable bracket (D) on control device assembly, make sure casing caps (C) is firmly secured in cable bracket (D) on control device assembly.
- If casing cap (C) is loose [less than 39.2 N (4.0 kg, 8.8 lb) removing force], replace key interlock cable.

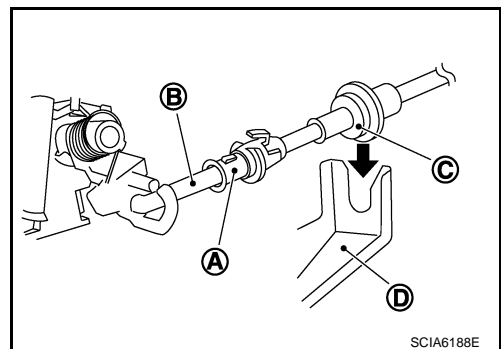

KEY INTERLOCK CABLE

< SERVICE INFORMATION >

8. Install shift knob in "P" position.
9. Pull the adjust holder (C) all the way to the left on the key interlock rod (B). Move the slider (A) toward the key interlock rod (B) and lock it.

CAUTION:

- Do not press tabs when holding slider (A).
- Do not apply any force to key interlock rod (B) when sliding slider (A).

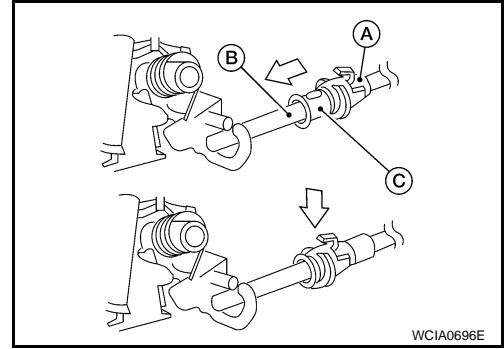

10. Secure the key interlock cable with the clip.
11. Installation of the remaining components is in the reverse order of removal.
12. Check shift lock system. Refer to [CVT-164, "Description"](#).

ON-VEHICLE SERVICE

< SERVICE INFORMATION >

ON-VEHICLE SERVICE

Oil Pan

INFOID:000000004407304

COMPONENTS

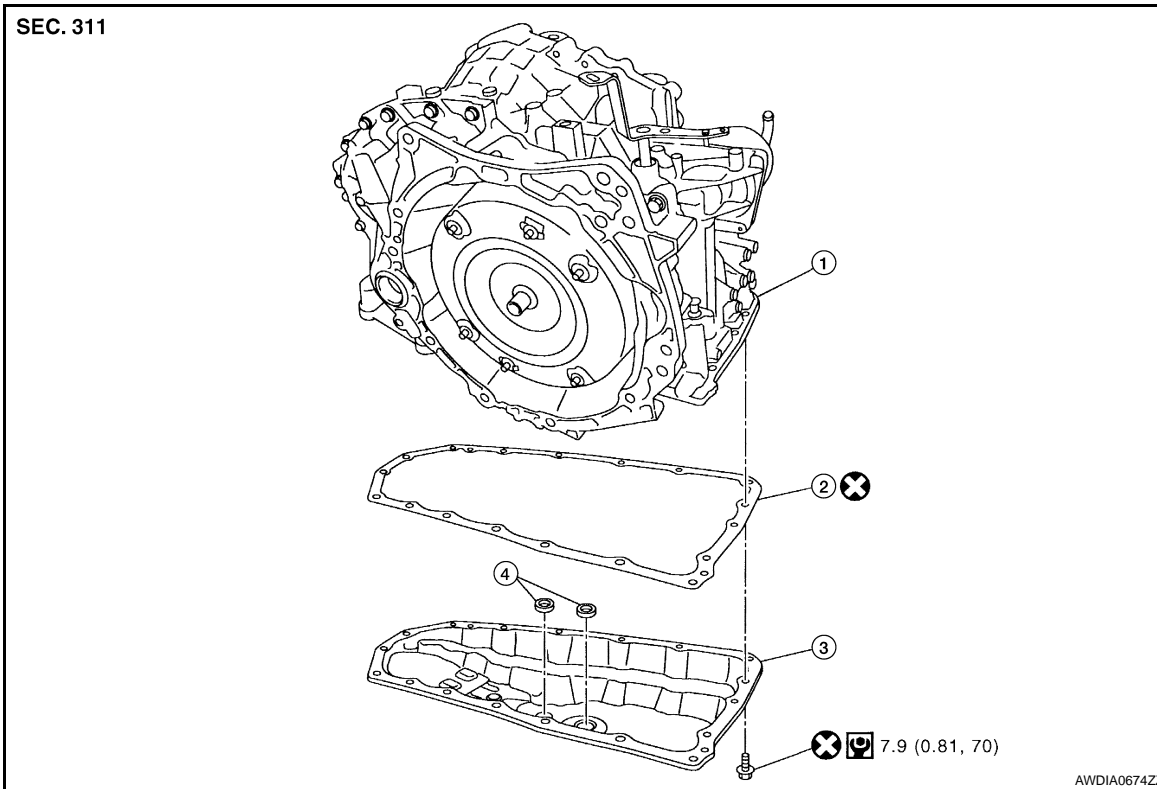

1. CVT assembly
2. Oil pan gasket
3. Oil pan
4. Magnet

Removal

1. Drain CVT fluid. Refer to [CVT-16. "Changing CVT Fluid"](#).
2. Remove oil pan bolts.
3. Remove oil pan and oil pan gasket.

CAUTION:

Check for foreign materials in the oil pan to help determine the cause of any malfunction. If the CVT fluid is very dark, smells burned, or contains foreign particles, frictional material (clutches) may need replacement. A tacky film that will not wipe clean indicates varnish build up. Varnish can cause valves to stick and can inhibit pump pressure.

Installation

1. Install the oil pan gasket to the oil pan.

CAUTION:

- Completely wipe out any moisture, oil, and old gasket from the oil pan gasket mating surface and bolt hole of oil pan and transaxle case.
- Never reuse oil pan gasket.

2. Install the oil pan assembly to the transaxle case, and then temporarily tighten the oil pan bolt.

CAUTION:

Never reuse oil pan bolts.

ON-VEHICLE SERVICE

< SERVICE INFORMATION >

3. Tighten the oil pan bolts in the order shown to the specified torque.
4. Tighten the oil pan bolts again clockwise from (1) shown to the specified torque.

CAUTION:

- After installation is complete, fill CVT with recommended CVT fluid and check for CVT fluid leakage and CVT fluid level. Refer to [CVT-15, "Checking CVT Fluid"](#).

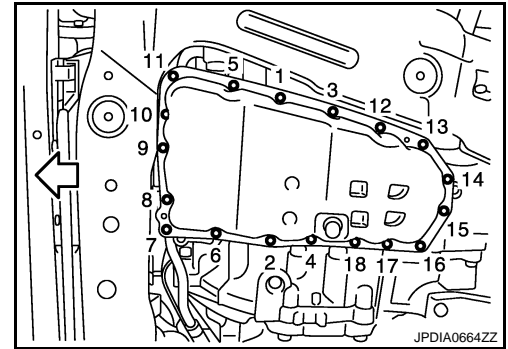

Control Valve

INFOID:000000004777151

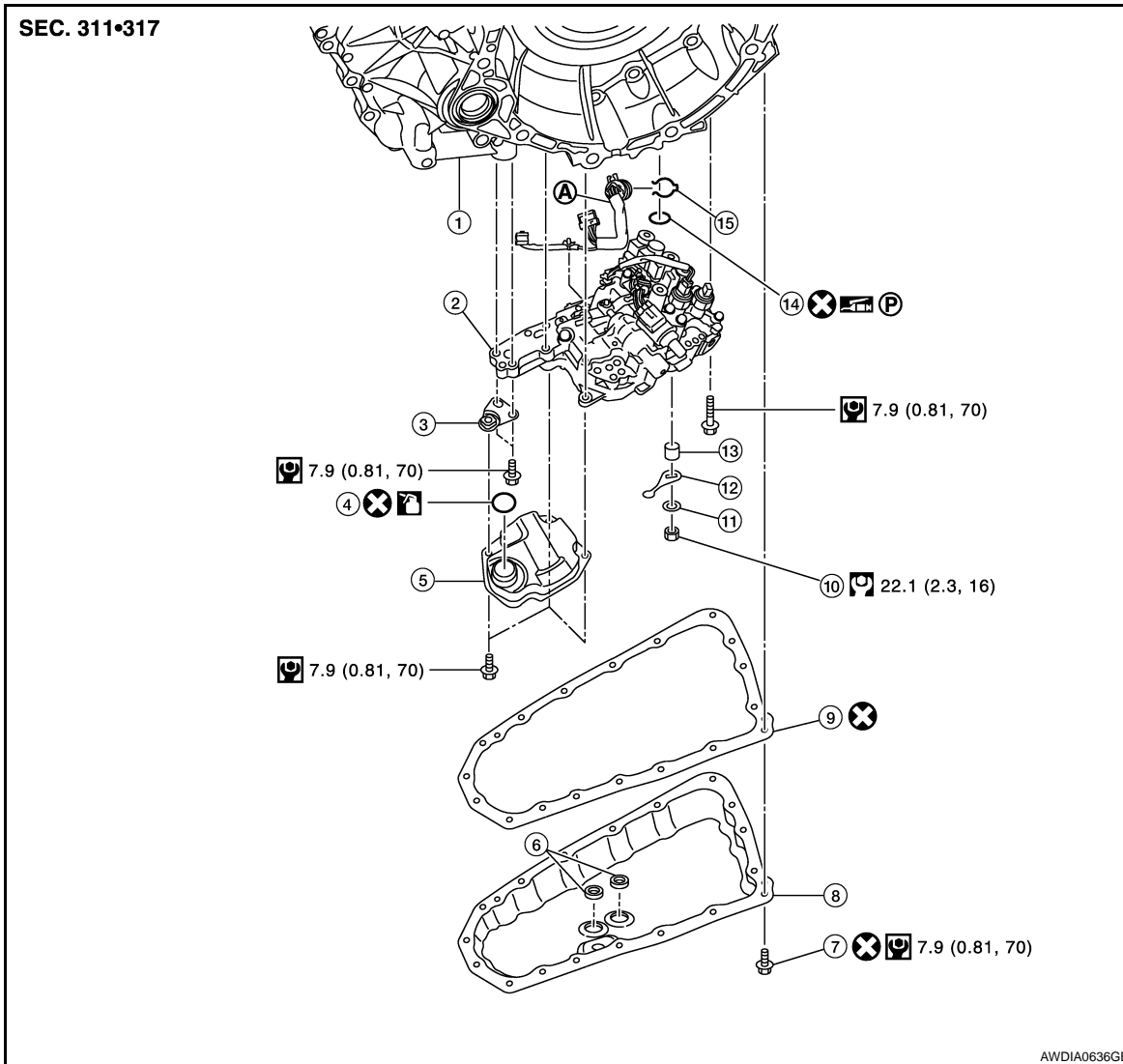

- | | | |
|-----------------------|--------------------------|-------------------|
| 1. Transaxle assembly | 2. Control valve | 3. Bracket |
| 4. O-ring | 5. Oil strainer assembly | 6. Magnet |
| 7. Oil pan bolt | 8. Oil pan | 9. Oil pan gasket |
| 10. Lock nut | 11. Washer | 12. Manual plate |
| 13. Collar | 14. Lip seal | 15. Snap ring |
| A. CVT unit connector | | |
| NISSAN CVT Fluid NS-2 | | |

ON-VEHICLE SERVICE

< SERVICE INFORMATION >

REMOVAL

1. Drain CVT fluid. Refer to [CVT-16, "Changing CVT Fluid"](#).
2. Disconnect battery cable from negative terminal. Refer to [SC-6, "Removal and Installation MR20DE"](#), or [SC-7, "Removal and Installation QR25DE"](#).
3. Disconnect the CVT unit connector. Refer to [CVT-9, "Removal and Installation Procedure for CVT Unit Connector"](#).
4. Remove the snap ring (1) from the CVT unit connector (A).

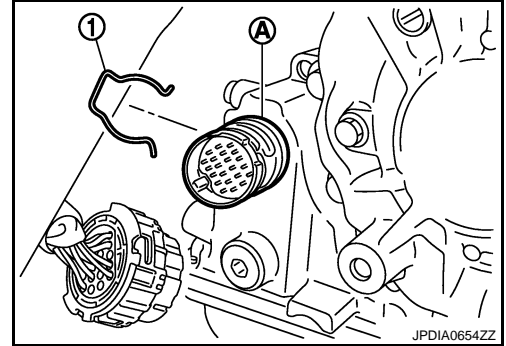

5. Press the CVT unit connector (A) into the transaxle case.
CAUTION:
Never damage the CVT unit connector.
NOTE:
 Clean around the connector to prevent foreign materials from entering into the transaxle case.

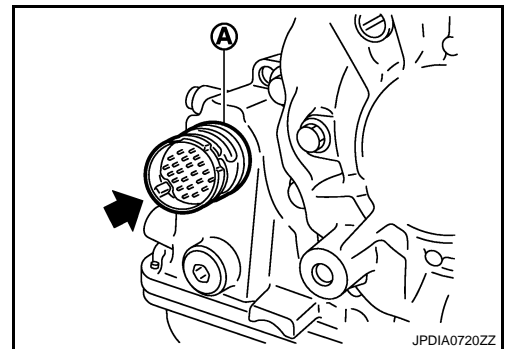

6. Remove the oil pan bolts, and then remove the oil pan and oil pan gasket.
7. Remove the magnets from the oil pan.
8. Remove the lock nut (1) and washer (2), and then remove the manual plate (3).

← : Vehicle front

9. Remove the collar (4) from the manual shaft (A).
CAUTION:
Never drop the collar.

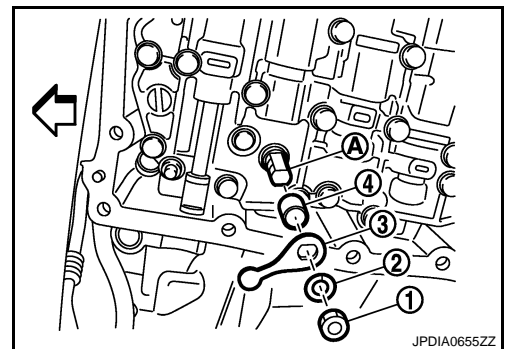

10. Disconnect the connectors (A) and (B).

← Clip
 ← : Vehicle front

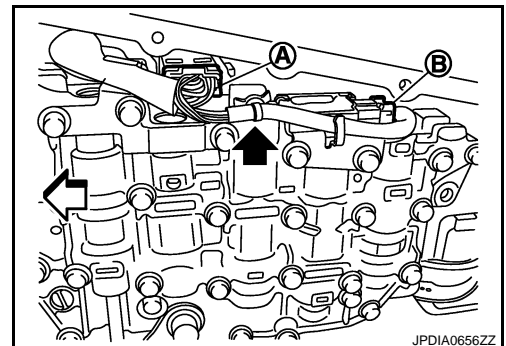

A
B
B
CVT
D
E
F
G
H
I
J
K
L
M
N
O
P

ON-VEHICLE SERVICE

< SERVICE INFORMATION >

11. Remove the oil strainer assembly bolts (A) and (B), and then remove the oil strainer assembly (1).

⇐ : Vehicle front

12. Remove O-ring from oil strainer assembly.

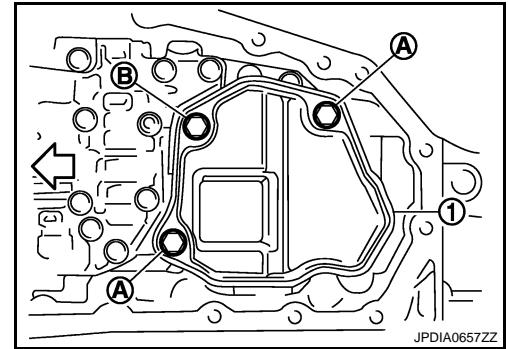

13. Remove the bracket (1).

← Bolt

⇐ : Vehicle front

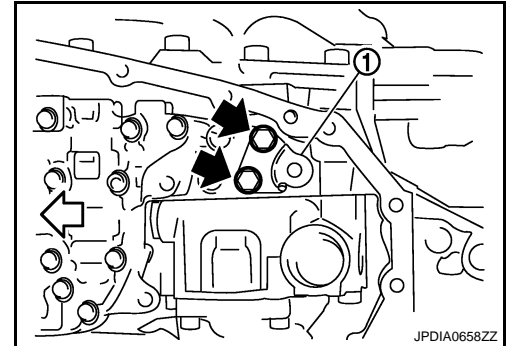

14. Remove the control valve bolts (A) and (B), and then remove the control valve from the transaxle case.

⇐ : Vehicle front

CAUTION:

Never drop the control valve, ratio control valve and manual shaft.

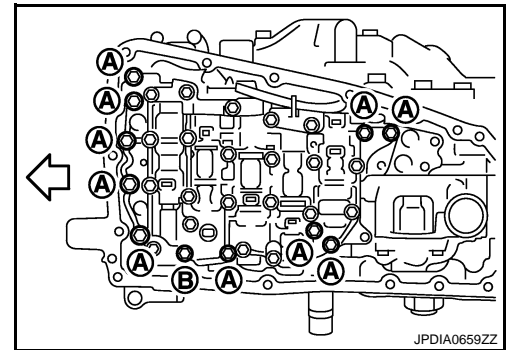

15. Remove CVT unit connector (A) from the transaxle case inside.

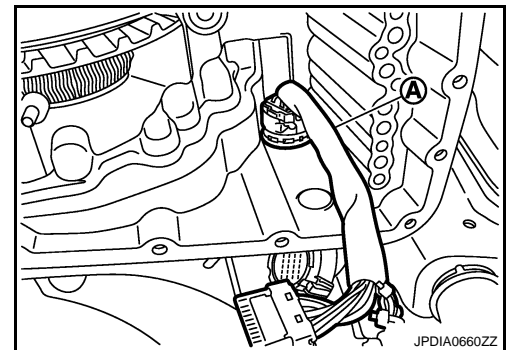

16. Remove the lip seal (1) from the transaxle case.

⇐ : Vehicle front

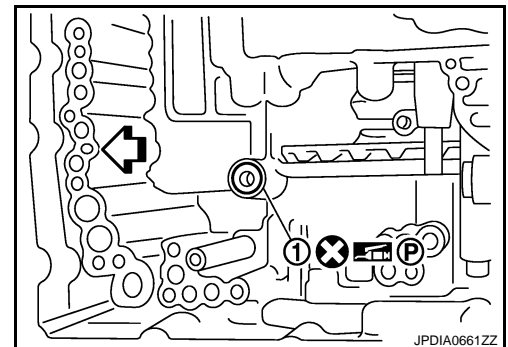

ON-VEHICLE SERVICE

< SERVICE INFORMATION >

INSTALLATION

1. Install the lip seal (1) to the transaxle case.

← : Vehicle front

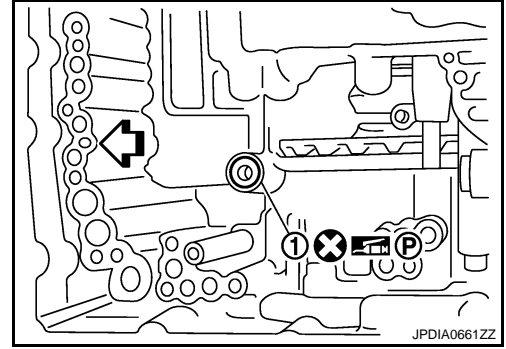

2. Install the CVT unit connector (A) to the transaxle case.

CAUTION:

Connect the CVT unit connector with the stopper facing up, and then press in until it clicks.

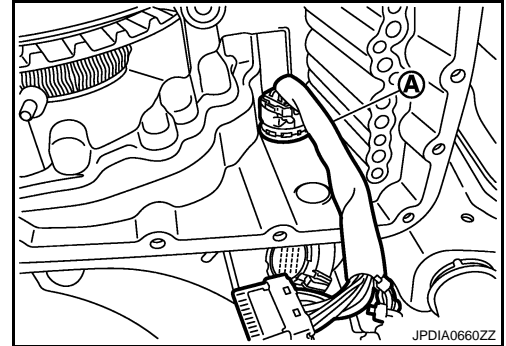

3. Press in the ratio control valve (B) in the (←) direction, and then fix the linkage in the position shown with the linkage pin (A) from the back of control valve through the hole for fixing.

4. Check that one end of linkage engages with the step motor end (C) and that the linkage is in the direction shown.

5. Install the control valve to the transaxle case.

CAUTION:

- Never drop the linkage pin. If it is dropped, repeat the installation procedure from step 3.
- Never pinch the harness into between the control valve and the transaxle case.

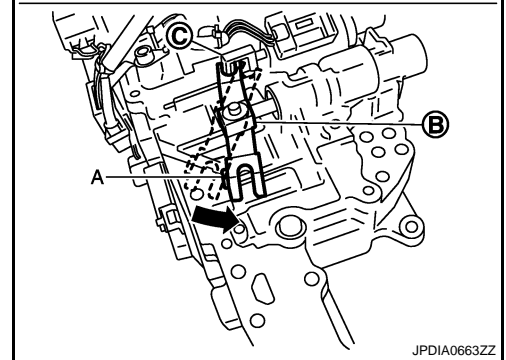
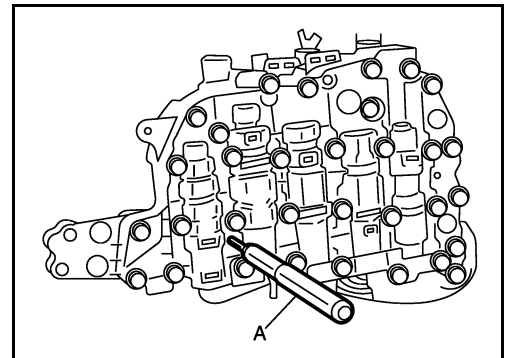

A
B
CVT
D
E
F
G
H
I
J
K
L
M
N
O
P

ON-VEHICLE SERVICE

< SERVICE INFORMATION >

6. Fix the control valve using the control valve bolts (A) and (B).

↶ : Vehicle front

Bolt	Bolt length (mm)	Number of bolts
A	54	10
B	44	1

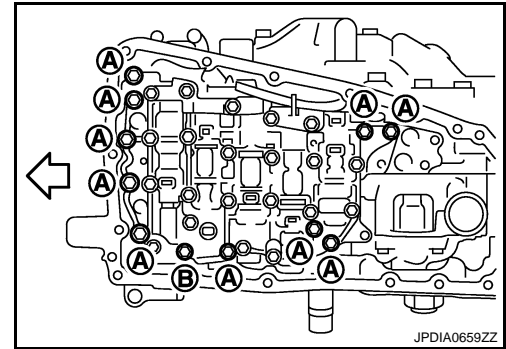

7. Pull the linkage pin out.
8. Connect the connectors (A) and (B).

← Clip
↶ : Vehicle front

CAUTION:

- Never pinch the harness into between the control valve and the transaxle case.
- Securely insert the connector until it clicks and locks.

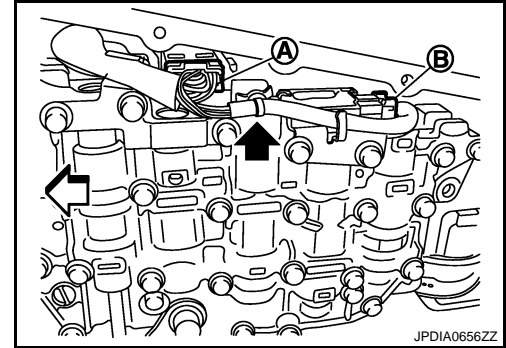

9. Install the bracket (1).

← Bolt
↶ : Vehicle front

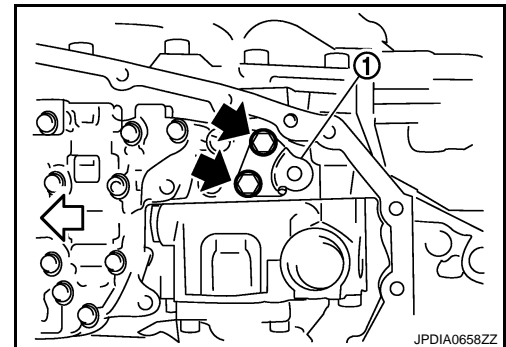

10. Install O-ring to oil strainer assembly.

CAUTION:

- Never reuse O-ring.
- Apply CVT fluid NS-2 to O-ring.

11. Install the oil strainer assembly (1) using the oil strainer assembly bolts (A) and (B).

↶ : Vehicle front

Bolt	Bolt length (mm)	Number of bolts
A	12	2
B	44	1

NOTE:

Remove the bracket and adjust the position again if the bolt hole positions are not aligned.

12. Install the collar to the manual shaft.

CAUTION:

Never drop the collar.

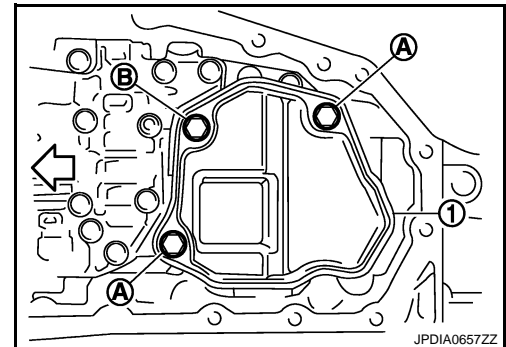

ON-VEHICLE SERVICE

< SERVICE INFORMATION >

13. Install the manual plate (1) while aligning with the groove (A) of the manual valve.

CAUTION:

Assemble the manual plate while aligning its end with the cutout (←) of the manual valve.

← : Vehicle front

14. Install the washer (2) and the lock-nut (3), and then tighten to the specified torque.

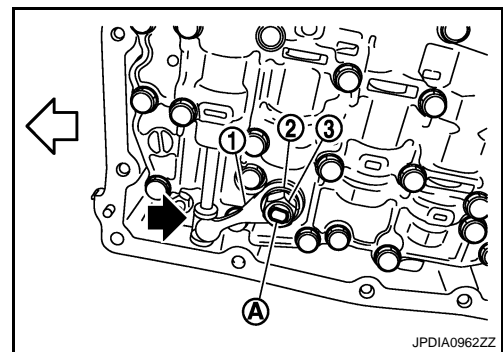

15. Install the snap ring (1) to the CVT unit connector (A).

16. Connect the CVT unit connector. Refer to [CVT-9, "Removal and Installation Procedure for CVT Unit Connector"](#).

17. Install the magnet while aligning it with the convex side of oil pan.

CAUTION:

Completely eliminate the iron powder from the magnet mounting area of oil pan and the magnet.

18. Install the oil pan to the transaxle case with the following procedure.

1. Install the oil pan gasket to the oil pan.

CAUTION:

- Completely wipe out any moisture, oil, and old gasket from the oil pan gasket mating surface and bolt hole of oil pan and transaxle case.
- Never reuse oil pan gasket.

2. Install the oil pan assembly to the transaxle case, and then temporarily tighten the oil pan bolt.

CAUTION:

Never reuse oil pan bolts.

3. Tighten the oil pan bolts in the order shown to the specified torque.

4. Tighten the oil pan bolts again clockwise from (1) shown to the specified torque.

19. Fill CVT fluid from CVT fluid charging pipe to the specified level.

CVT fluid : Refer to [CVT-15, "Checking CVT Fluid"](#).

Fluid capacity : Refer to [MA-41, "Checking CVT Fluid"](#).

CAUTION:

- Use only Genuine NISSAN CVT Fluid NS-2. Never mix with other fluid.
- Using CVT fluid other than Genuine NISSAN CVT Fluid NS-2 will deteriorate in driveability and CVT durability, and may damage the CVT, which is not covered by the warranty.
- When filling CVT fluid, take care not to scatter heat generating parts such as exhaust.
- Sufficiently shake the container of CVT fluid before using.
- Delete CVT fluid deterioration date with CONSULT-III after changing CVT fluid. Refer to [CVT-47, "CONSULT-III Function \(TRANSMISSION\)"](#).

20. With the engine warmed up, drive the vehicle in an urban area.

NOTE:

When ambient temperature is 20°C (68°F), it takes about 10 minutes for the CVT fluid to warm up to 50° to 80°C (122° to 176°F).

21. Check CVT fluid level and condition. Refer to [MA-41, "Checking CVT Fluid"](#).

22. Connect battery cable to negative terminal. Refer to [SC-6, "Removal and Installation MR20DE"](#) or [SC-7, "Removal and Installation QR25DE"](#).

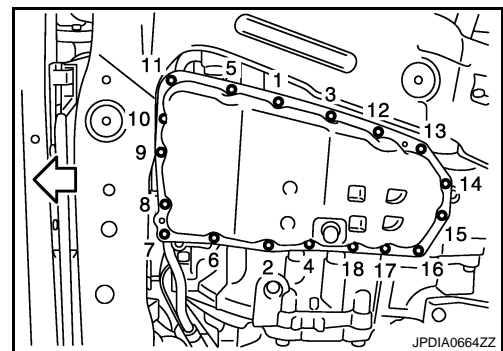
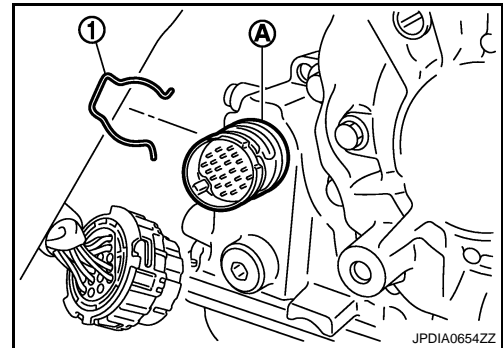

INSPECTION AFTER REMOVAL

Check oil pan for foreign material.

ON-VEHICLE SERVICE

< SERVICE INFORMATION >

- If a large amount of worn material is found, clutch plate may be worn.
- If iron powder is found, bearings, gears, or clutch plates may be worn.
- If aluminum powder is found, bushing may be worn, or chips or burrs of aluminum casting parts may enter. Check points where wear is found in all cases.

INSPECTION AFTER REMOVAL

Check the CVT fluid level and leakage. Refer to [MA-41, "Checking CVT Fluid"](#).

INSPECTION AFTER INSTALLATION

Erase the TCM data.

- Erase the CVT fluid degradation data. Refer to [CVT-47, "CONSULT-III Function \(TRANSMISSION\)"](#).
- Erase the memory of EEPROM in the TCM. Refer to [CVT-146, "CONSULT-III Reference Value"](#).

Park/Neutral Position (PNP) Switch

INFOID:000000004407305

COMPONENTS

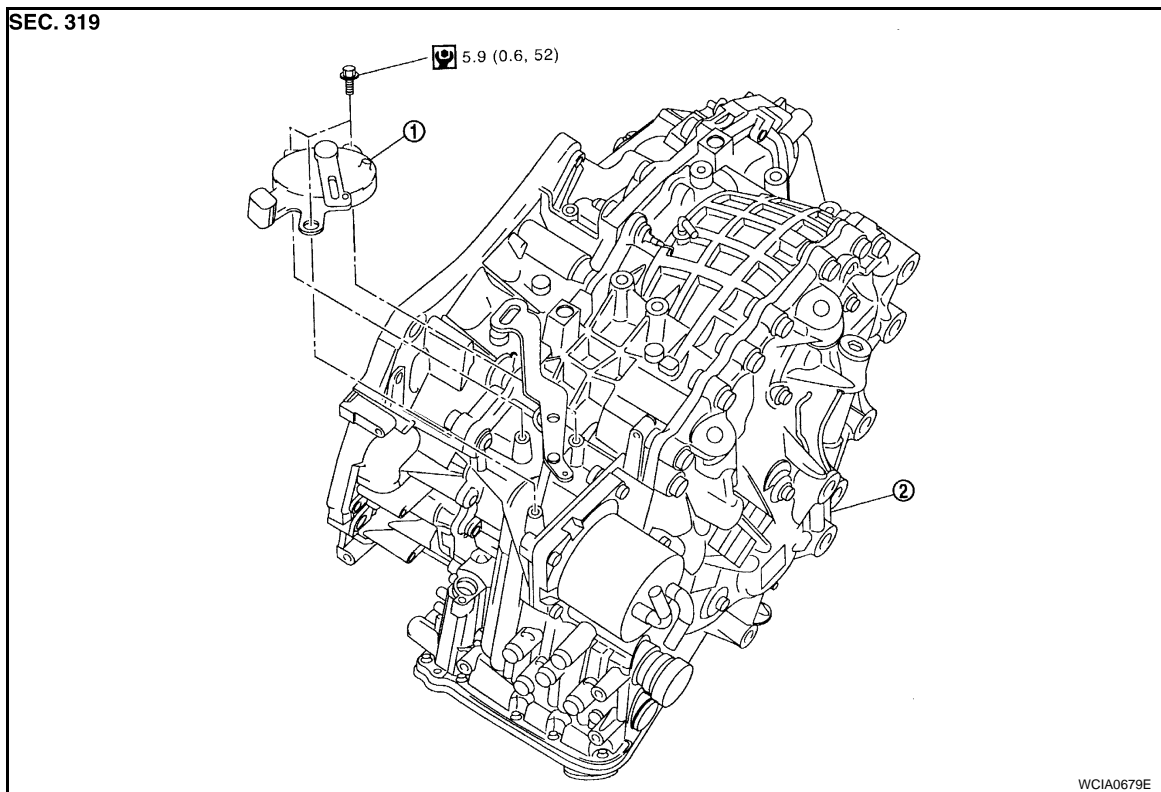

1. PNP switch

2. CVT assembly

NOTE:

- Align PNP switch position when installing.
- After installation of PNP switch, check the continuity of PNP switch. Refer to [CVT-171, "Adjustment of PNP switch"](#).
- After installation is complete, adjust and check CVT position. Refer to [CVT-170, "Adjustment of CVT Position"](#), [CVT-170, "Checking of CVT Position"](#).

Primary Speed Sensor

INFOID:000000004407306

COMPONENTS

ON-VEHICLE SERVICE

< SERVICE INFORMATION >

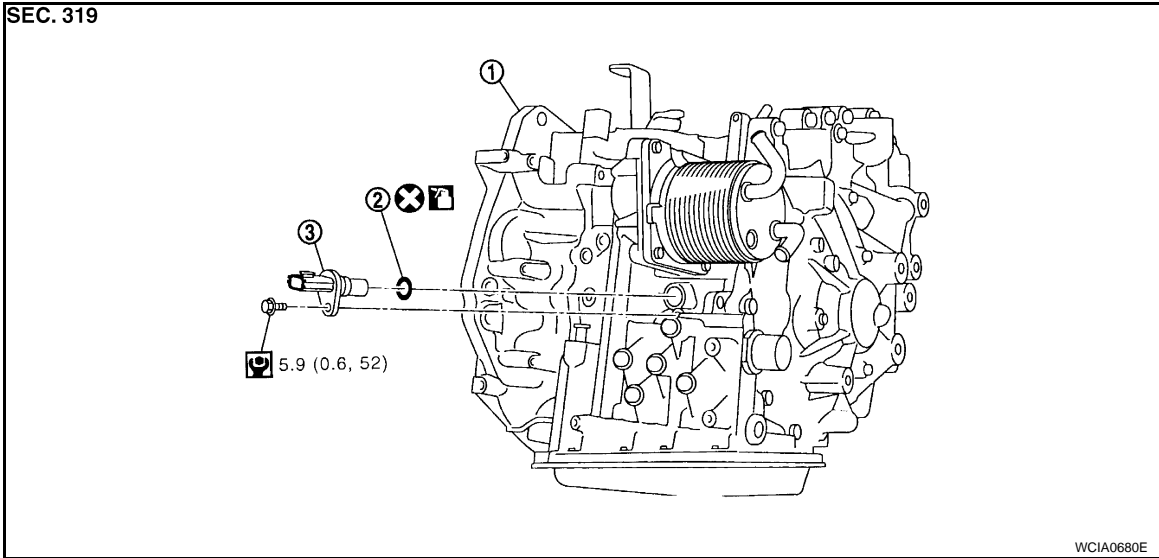

1. CVT assembly

2. O-ring

3. Primary speed sensor

CAUTION:

- Do not reuse O-ring.
- Apply CVT fluid to O-ring.
- After installation is complete, check for CVT fluid leakage and CVT fluid level. Refer to [CVT-15, "Checking CVT Fluid"](#).

Secondary Speed Sensor

INFOID:000000004407307

COMPONENTS

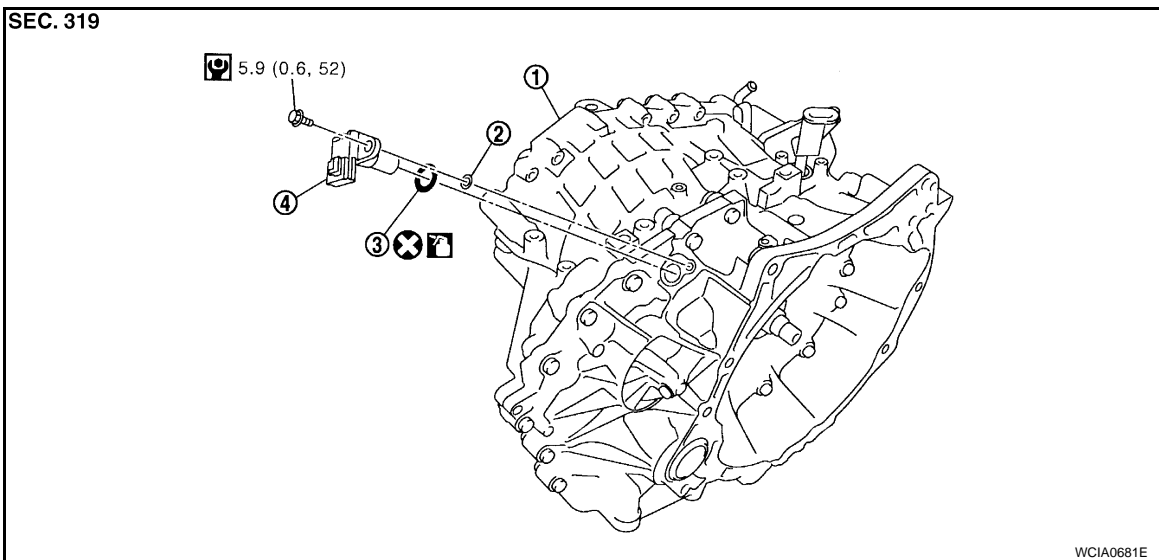

1. CVT assembly

2. Shim

3. O-ring

4. Secondary speed sensor

CAUTION:

- Do not reuse O-ring.
- Apply CVT fluid to O-ring.
- Insert the shim.
- After installation is complete, check for CVT fluid leakage and CVT fluid level. Refer to [CVT-15, "Checking CVT Fluid"](#).

A
B
CVT
D
E
F
G
H
I
J
K
L
M
N
O
P

ON-VEHICLE SERVICE

< SERVICE INFORMATION >

Differential Side Oil Seal

INFOID:000000004407308

COMPONENTS

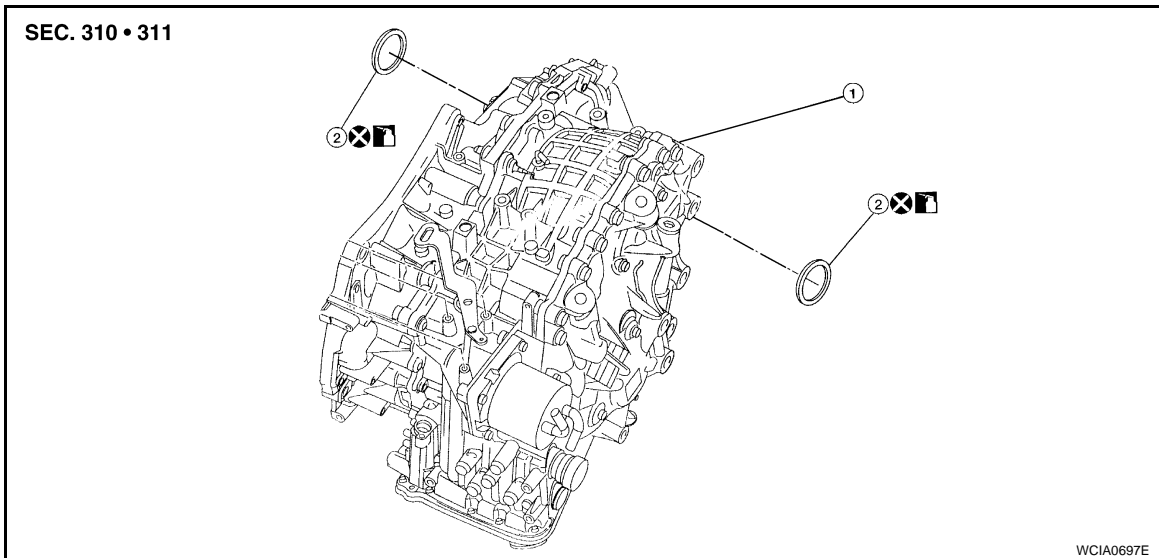

1. CVT assembly
2. Differential oil seal

 :Apply CVT Fluid. Refer to [MA-14, "MR20DE"](#).

REMOVAL

1. Remove front drive shaft from CVT assembly. Refer to [FAX-9](#).
2. Remove differential side oil seal using suitable tool.

CAUTION:

Do not scratch CVT case or converter housing.

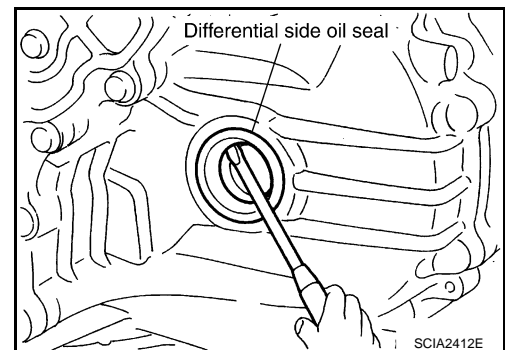

INSTALLATION

1. Drive the new differential side oil seal in until it is flush using Tool.

Tool number : KV38100300 (—)

CAUTION:

- Do not reuse differential side oil seals.
- Apply CVT fluid to the new differential side oil seals.

2. Install drive shaft assembly. Refer to [FAX-9](#).
3. Check for CVT fluid leakage and CVT fluid level. Refer to [CVT-15, "Checking CVT Fluid"](#).

Oil Pump Fitting Bolt

INFOID:000000004407309

NOTE:

Replace the oil pump fitting bolt and the O-ring if oil leaks or exudes from the oil pump fitting bolt.

COMPONENTS

ON-VEHICLE SERVICE

< SERVICE INFORMATION >

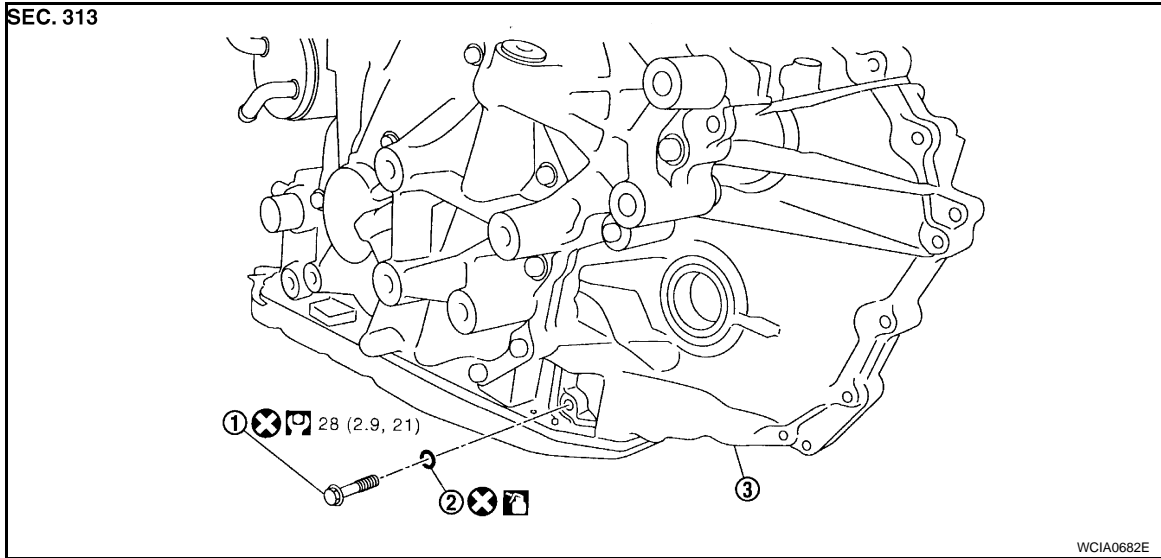

1. Oil pump fitting bolt 2. O-ring 3. CVT assembly

 : Apply CVT Fluid. Refer to [MA-14, "MR20DE"](#).

CAUTION:

- Do not reuse O-ring.
- Apply CVT fluid to O-ring.
- After installation is complete, check for CVT fluid leakage and CVT fluid level. Refer to [CVT-15, "Checking CVT Fluid"](#).

A
B
CVT
D
E
F
G
H
I
J
K
L
M
N
O
P

AIR BREATHER HOSE

< SERVICE INFORMATION >

AIR BREATHER HOSE

Removal and Installation (MR20DE)

INFOID:000000004407310

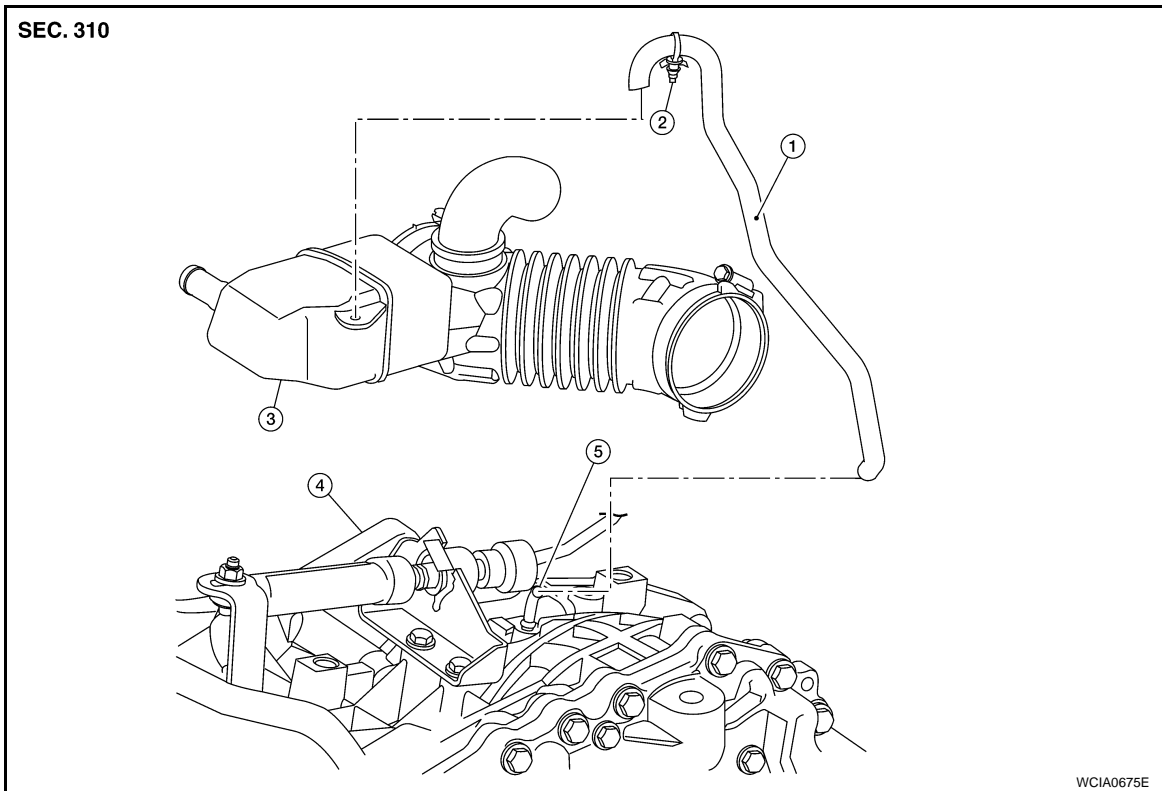

- | | | |
|----------------------|----------------------|--------------|
| 1. Air breather hose | 2. Clip | 3. Resonator |
| 4. CVT assembly | 5. Air breather tube | |

CAUTION:

Make sure air breather hose not collapsed or blocked due to folding or bending when installed.

NOTE:

- Install the air breather hose (3) to the air breather tube (4) so that the paint mark (A) faces upward. Also make sure the air breather hose end is pushed up to the tube bend position.
- When installing air breather hose (3) to the resonator (1) make sure to fully insert the clip (2).

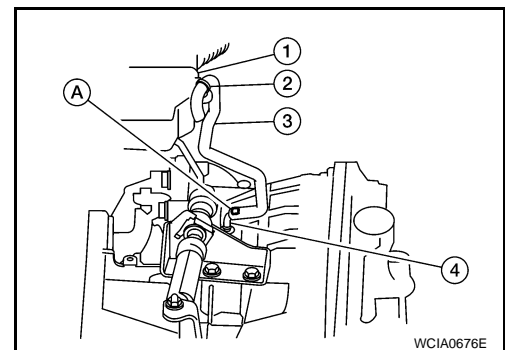

AIR BREATHER HOSE

< SERVICE INFORMATION >

Removal and Installation (QR25DE)

INFOID:000000004407311

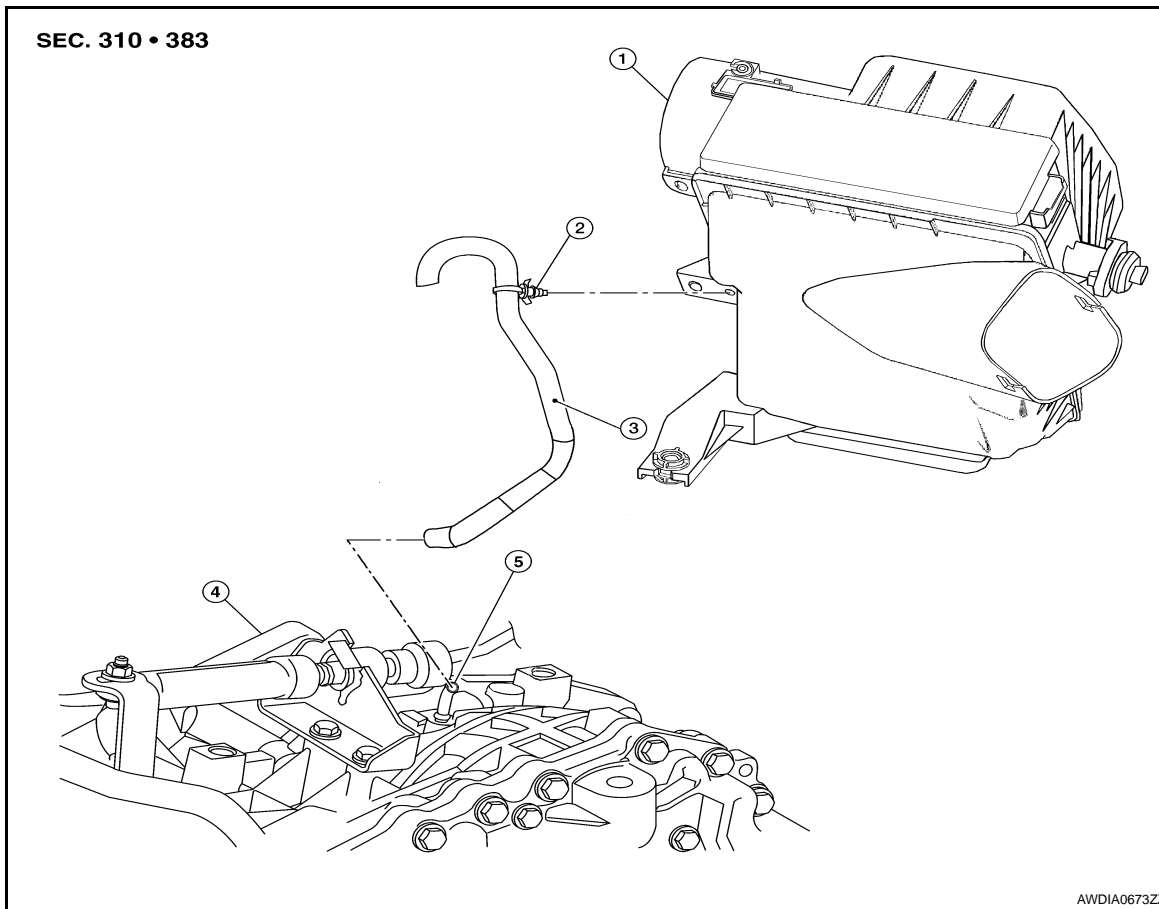

1. Air cleaner case

2. Clip

3. Air breather hose

4. CVT assembly

5. Air breather tube

CAUTION:

Make sure air breather hose not collapsed or blocked due to folding or bending when installed.

NOTE:

- Install the air breather hose to the air breather tube so that the paint mark faces upward. Also make sure the air breather hose end is pushed up to the tube bend position.
- When installing air breather hose to the air cleaner case make sure to fully insert the clip.

CVT FLUID COOLER SYSTEM

< SERVICE INFORMATION >

CVT FLUID COOLER SYSTEM

CVT Fluid Cooler Removal and Installation (MR20DE)

INFOID:000000004407312

COMPONENTS

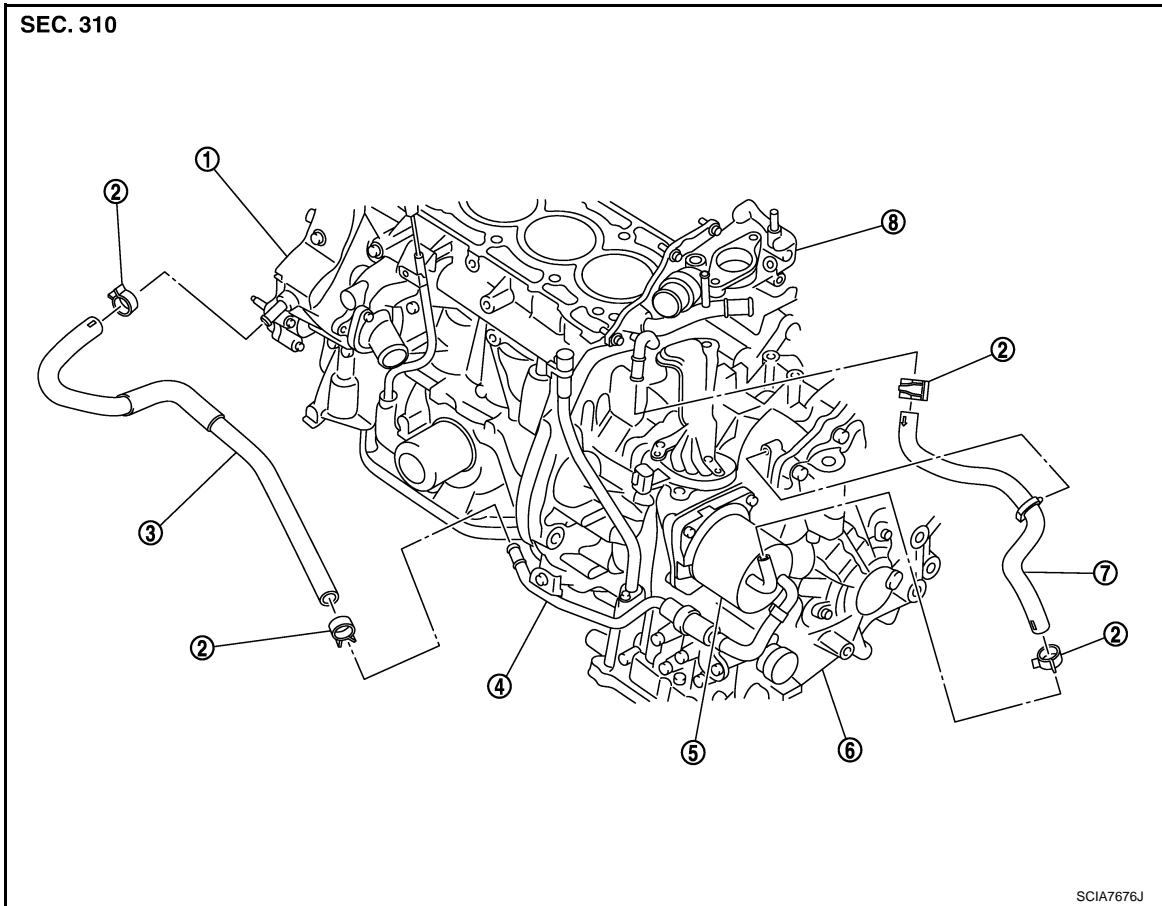

- | | | |
|--------------------------|--------------------------|-------------------|
| 1. Water pump | 2. Hose clamp | 3. CVT water hose |
| 4. Water thermostat tube | 5. CVT fluid cooler | 6. CVT assembly |
| 7. CVT water hose | 8. Engine coolant outlet | |

CVT Fluid Cooler Removal and Installation (QR25DE)

INFOID:000000004407313

COMPONENTS

CVT FLUID COOLER SYSTEM

< SERVICE INFORMATION >

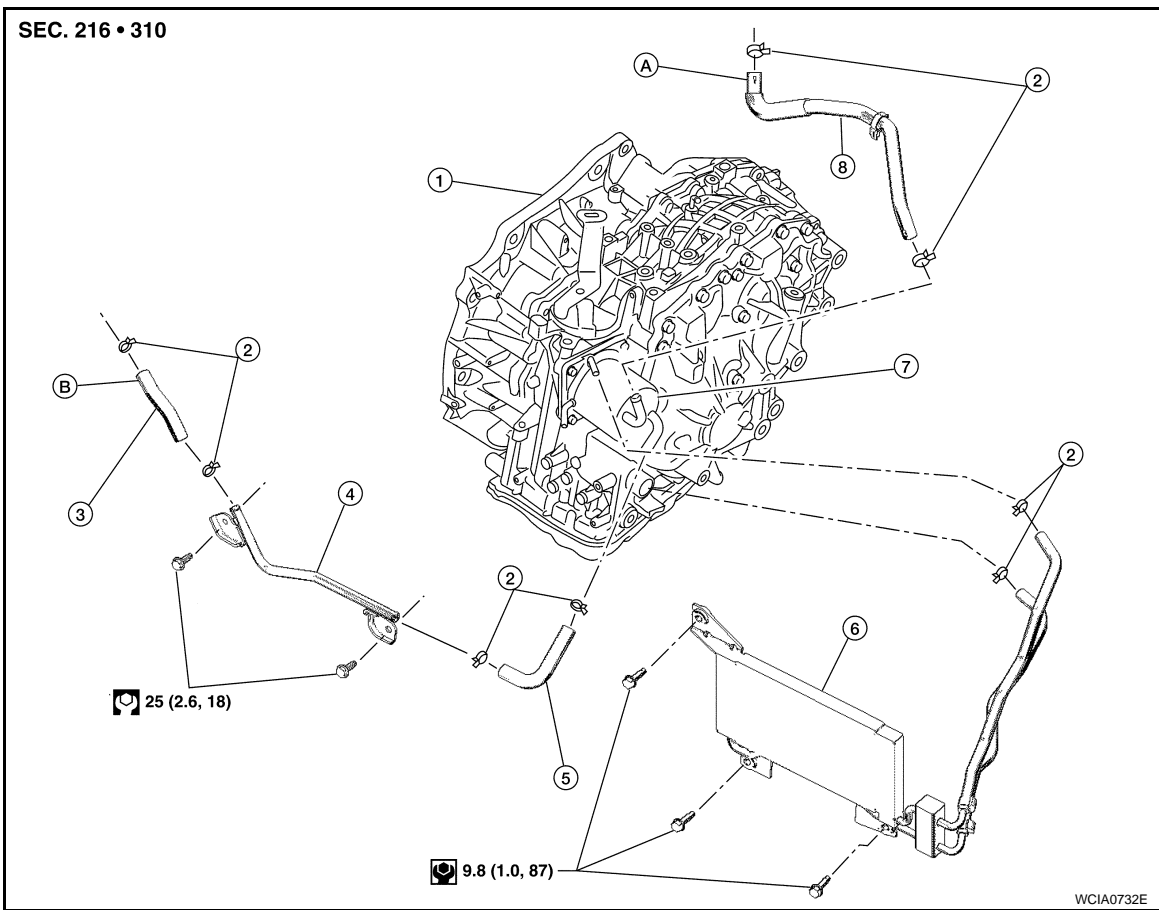

- | | | |
|---------------------|-------------------|------------------------------|
| 1. CVT assembly | 2. Hose clamp | 3. CVT water hose |
| 4. Water tube | 5. Water hose | 6. CVT fluid cooler assembly |
| 7. CVT fluid cooler | 8. CVT water hose | A. To engine coolant outlet |
| B. To heater pipe | | |

NOTE:

Install and torque the CVT cooler assembly bolts to the specified torque in the order shown.

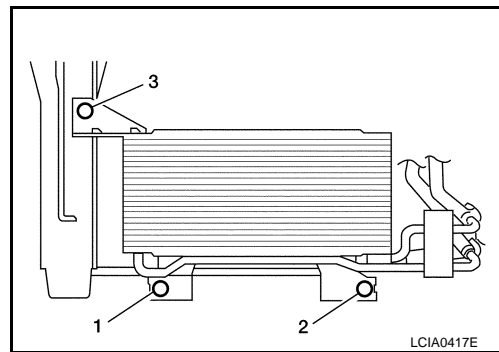

A
B
CVT
D
E
F
G
H
I
J
K
L
M
N
O
P

TRANSAXLE ASSEMBLY

< SERVICE INFORMATION >

TRANSAXLE ASSEMBLY

Removal and Installation (MR20DE)

INFOID:000000004407314

COMPONENTS

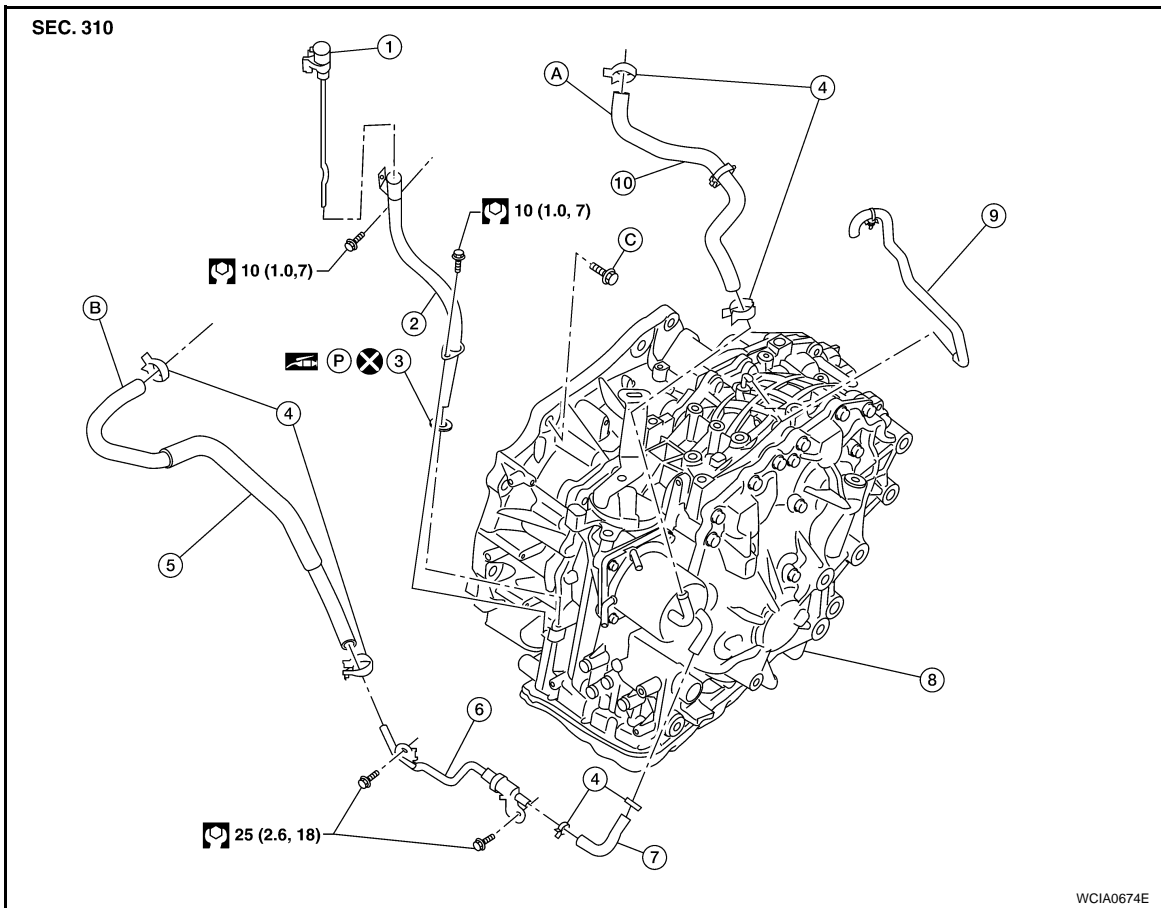

- | | | |
|-----------------------------|-----------------------------|--------------------------|
| 1. CVT fluid level gauge | 2. CVT fluid charging pipe | 3. O-ring |
| 4. Hose clamp | 5. CVT water hose | 6. Water thermostat tube |
| 7. Water hose | 8. Transaxle assembly | 9. Air breather hose |
| 10. CVT water hose | A. To engine coolant outlet | B. To water pump |
| C. Refer to "INSTALLATION". | | |

REMOVAL

1. Remove the engine and transaxle as an assembly. Refer to [EM-102. "Removal and Installation"](#).
2. Disconnect the electrical connectors from the following:
 - Secondary speed sensor (1)
 - Primary speed sensor (2)
 - CVT unit connector (3)
 - PNP switch (4)
3. Remove the harness from the CVT.

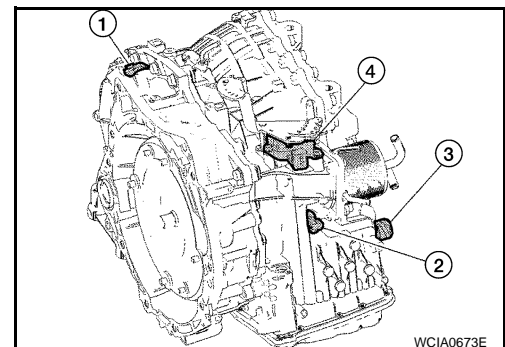

TRANSAXLE ASSEMBLY

< SERVICE INFORMATION >

4. Remove the four drive plate to torque converter nuts.

NOTE:

Rotate the crankshaft clockwise viewed from front of engine for access to drive plate to torque converter nuts.

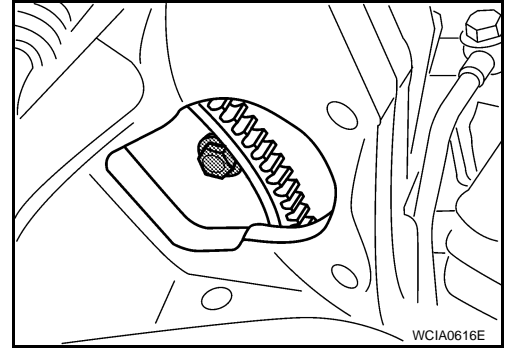

5. Put matching marks on the drive plate and torque converter alignment stud.

CAUTION:

For matching marks, use paint. Never damage the drive plate or torque converter.

6. Remove the CVT to engine and engine to CVT bolts.
7. Separate the CVT from the engine.
8. If necessary, remove the following from the CVT:
 - Primary speed sensor
 - Secondary speed sensor
 - PNP switch
 - CVT fluid charging pipe
 - Engine mounting bracket (LH)
 - Water tube and hoses
 - Air breather hose
 - Any necessary brackets

INSTALLATION

Installation is in the reverse order of removal.

CAUTION:

- When replacing an engine or transmission you must make sure any dowels are installed correctly during re-assembly.
- Improper alignment caused by missing dowels may cause vibration, oil leaks or breakage of drive train components.
- Do not reuse O-rings.
- When turning crankshaft, turn it clockwise as viewed from the front of the engine.
- When tightening the nuts for the torque converter while securing the crankshaft pulley bolt, be sure to confirm the tightening torque of the crankshaft pulley bolt. Refer to [EM-40](#).
- After converter is installed to drive plate, rotate crankshaft several turns to check that CVT rotates freely without binding.
- When installing the torque converter to the CVT measure distance A.

Distance "A": 14.4 mm (0.567 in)

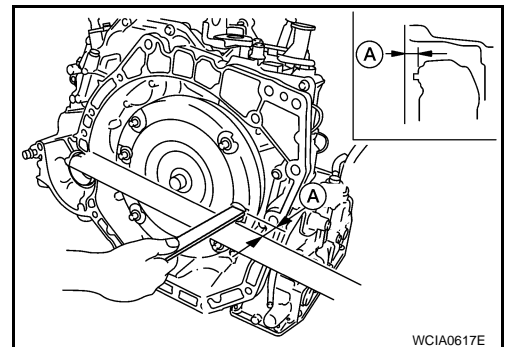

- When installing the CVT to the engine, align the matching mark on the drive plate with the matching mark on the torque converter alignment stud.

TRANSAXLE ASSEMBLY

< SERVICE INFORMATION >

- When installing CVT to the engine, attach the bolts in accordance with the following standard.

Bolt No.	1 (CVT to engine)	2 (Engine to CVT)
Number of bolts	2	7
Bolt length "A" mm (in)	55 (2.17)	50 (1.97)
Tightening torque N·m (kg·m, ft·lb)	62 (6.3, 46)	

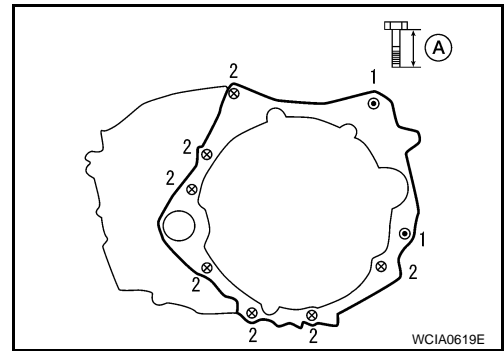

- When installing the drive plate to torque converter nuts, tighten them temporarily. Then tighten the nuts to the specified torque.

Converter nuts : 51 N·m (5.2 kg·m, 38 ft·lb)

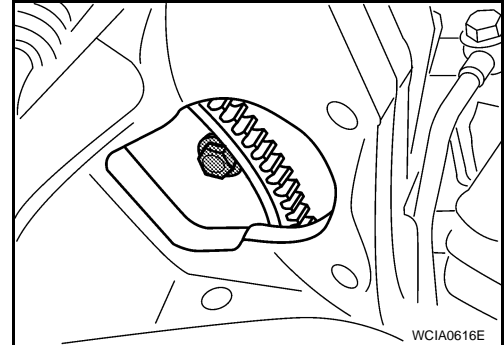

- After completing installation, check for fluid leakage, fluid level, and the positions of CVT. Refer to [CVT-15. "Checking CVT Fluid"](#), [CVT-170. "Adjustment of CVT Position"](#), [CVT-170. "Checking of CVT Position"](#).
- When replacing the CVT assembly, erase EEP ROM in TCM. Refer to [CVT-8. "Service After Replacing TCM and Transaxle Assembly"](#).

Removal and Installation (QR25DE)

INFOID:000000004407315

COMPONENTS

TRANSAXLE ASSEMBLY

< SERVICE INFORMATION >

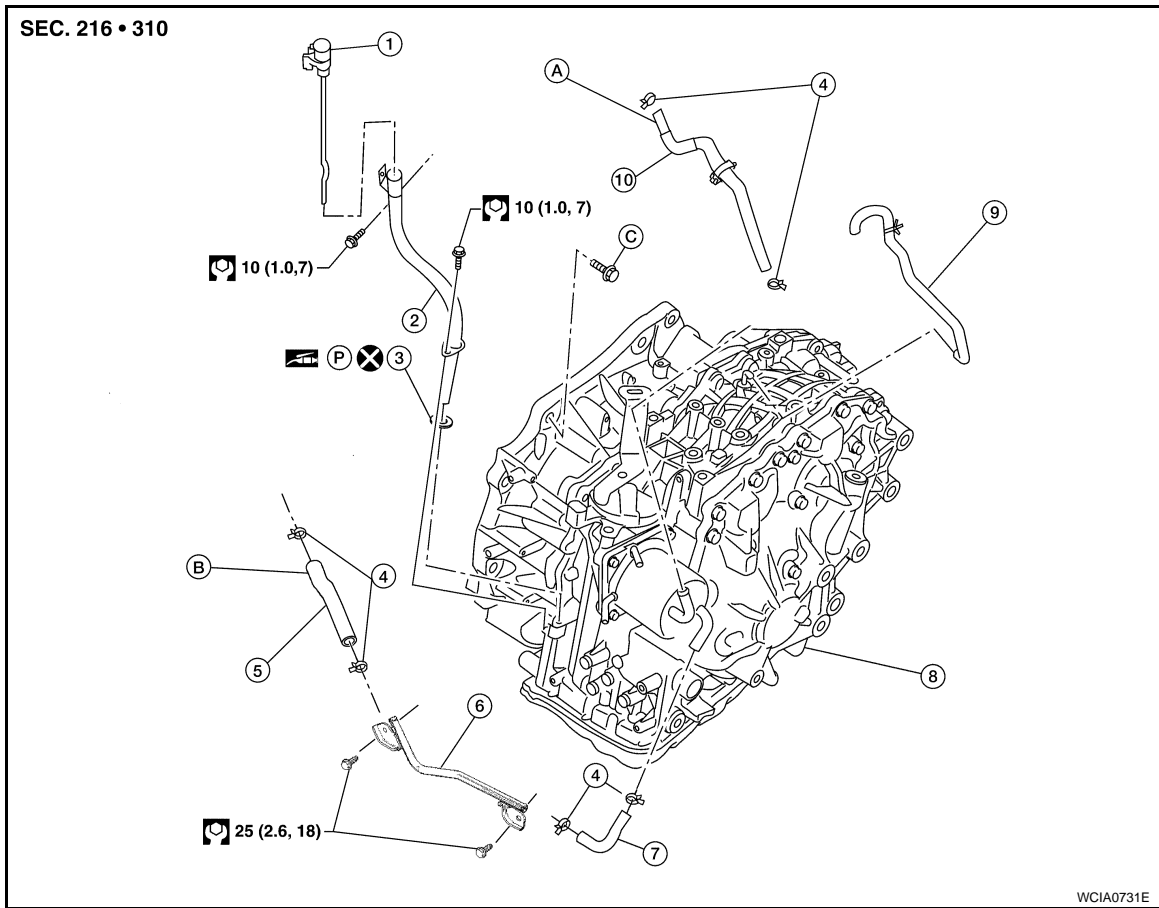

- | | | |
|-----------------------------|-----------------------------|----------------------|
| 1. CVT fluid level gauge | 2. CVT fluid charging pipe | 3. O-ring |
| 4. Hose clamp | 5. CVT water hose | 6. Water tube |
| 7. Water hose | 8. Transaxle assembly | 9. Air breather hose |
| 10. CVT water hose | A. To engine coolant outlet | B. To heater pipe |
| C. Refer to "INSTALLATION". | | |

REMOVAL

- Remove the engine and transaxle as an assembly. Refer to [EM-182. "Removal and Installation"](#).
- Disconnect the electrical connectors from the following:
 - Secondary speed sensor (1)
 - Primary speed sensor (2)
 - CVT unit connector (3)
 - PNP switch (4)
- Remove the harness from the CVT.

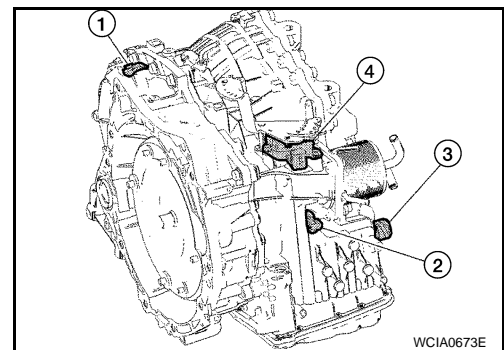

- Remove the four drive plate to torque converter nuts.

NOTE:
Rotate the crankshaft clockwise viewed from front of engine for access to drive plate to torque converter nuts.
- Put matching marks on the drive plate and torque converter alignment stud.

CAUTION:
For matching marks, use paint. Never damage the drive plate or torque converter.
- Remove the CVT to engine and engine to CVT bolts.

A
B
CVT
D
E
F
G
H
I
J
K
L
M
N
O
P

TRANSAXLE ASSEMBLY

< SERVICE INFORMATION >

7. Separate the CVT from the engine.
8. If necessary, remove the following from the CVT:
 - Primary speed sensor
 - Secondary speed sensor
 - PNP switch
 - CVT fluid charging pipe
 - Engine mounting bracket (LH)
 - Water tube and hoses
 - Air breather hose
 - Any necessary brackets

INSTALLATION

Installation is in the reverse order of removal.

CAUTION:

- When replacing an engine or transmission you must make sure any dowels are installed correctly during re-assembly.
- Improper alignment caused by missing dowels may cause vibration, oil leaks or breakage of drive train components.
- Do not reuse O-rings.
- When turning crankshaft, turn it clockwise as viewed from the front of the engine.
- When tightening the nuts for the torque converter while securing the crankshaft pulley bolt, be sure to confirm the tightening torque of the crankshaft pulley bolt. Refer to [EM-161](#).
- After converter is installed to drive plate, rotate crankshaft several turns to check that CVT rotates freely without binding.
- When installing the torque converter to the CVT measure distance A.

Distance "A": 14.4 mm (0.567 in)

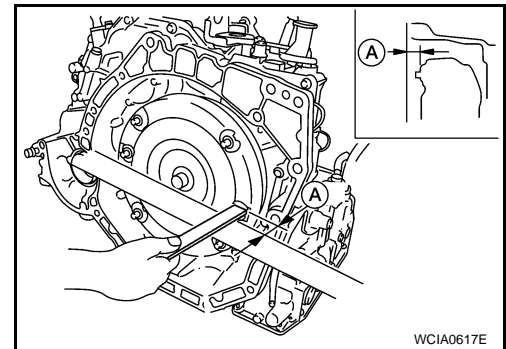

- When installing the CVT to the engine, align the matching mark on the drive plate with the matching mark on the torque converter alignment stud.
- When installing CVT to the engine, attach the bolts in accordance with the following standard.

Bolt No.	1 (CVT to engine)	2 (CVT to engine)	3 (Engine to CVT)	4 (Engine to CVT)	5 (Engine to CVT)	6 (Engine to CVT)
Number of bolts	1	4	2	2	1	2
Bolt length "A" mm (in)	45 (1.77)	45 (1.77)	45 (1.77)	35 (1.38)	45 (1.77)	45 (1.77)
Tightening torque N-m (kg-m, ft-lb)	35 (3.6, 26)	75 (7.6, 55)	42.7 (4.4, 31)	42.7 (4.4, 31)	62 (6.3, 46)	62 (6.3, 46)

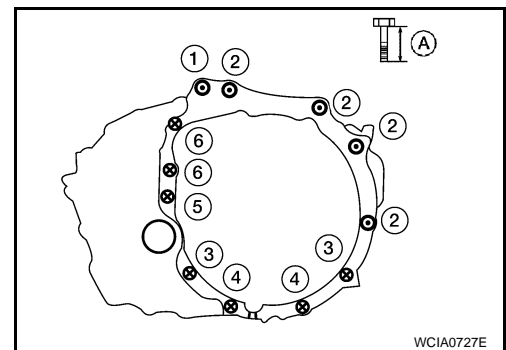

- When installing the drive plate to torque converter nuts, tighten them temporarily. Then tighten the nuts to the specified torque.

Converter nuts : 51 N-m (5.2 kg-m, 38 ft-lb)

- After completing installation, check for fluid leakage, fluid level, and the positions of CVT. Refer to [CVT-15, "Checking CVT Fluid"](#), [CVT-170, "Adjustment of CVT Position"](#), [CVT-170, "Checking of CVT Position"](#).
- When replacing the CVT assembly, erase EEP ROM in TCM. Refer to [CVT-8, "Service After Replacing TCM and Transaxle Assembly"](#).

REPAIR FOR COMPONENT PARTS

< SERVICE INFORMATION >

REPAIR FOR COMPONENT PARTS

Torque Converter and Converter Housing Oil Seal

INFOID:000000004407316

COMPONENTS

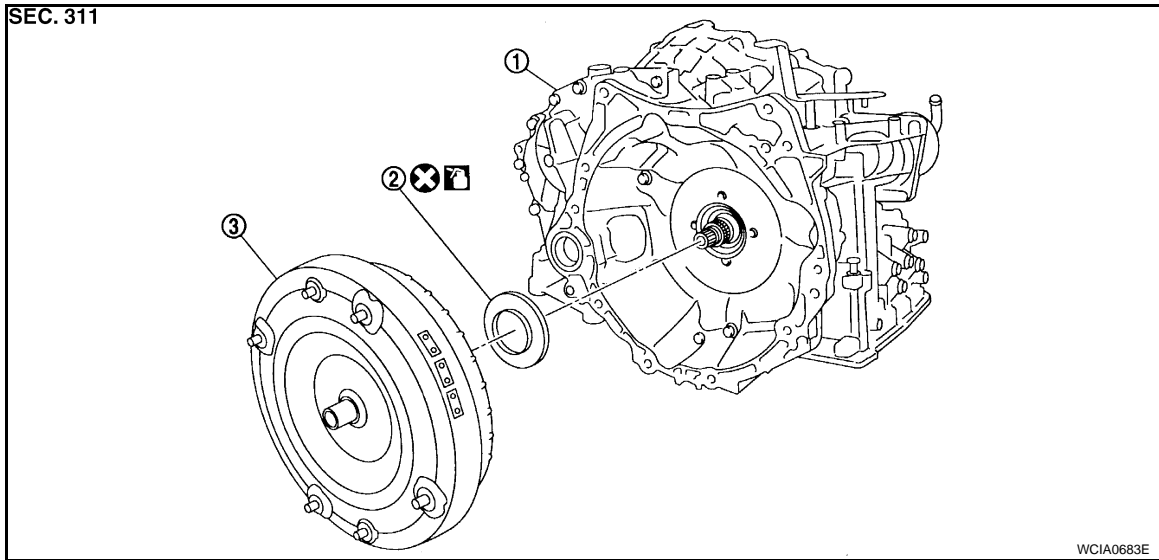

1. Transaxle assembly

2. Converter housing oil seal

3. Torque converter

 : Apply CVT Fluid NS-2.

Disassembly

1. Remove torque converter.
2. Remove the converter housing oil seal using suitable tool.

CAUTION:

Do not scratch converter housing.

Assembly

1. Drive the converter housing oil seal (1) in evenly using suitable tool as shown.
 - CVT (2)**CAUTION:**
 - **Do not reuse converter housing oil seal.**
 - **Apply CVT fluid to converter housing oil seal.**

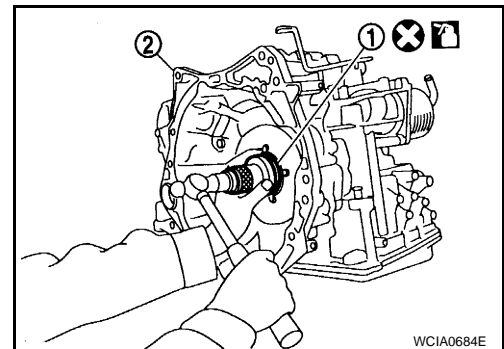

A
B
CVT
D
E
F
G
H
I
J
K
L
M
N
O
P

SERVICE DATA AND SPECIFICATIONS (SDS)

< SERVICE INFORMATION >

SERVICE DATA AND SPECIFICATIONS (SDS)

General Specification

INFOID:000000004407317

Applied model		MR20DE engine	QR25DE engine
CVT model		RE0F10A	
CVT assembly	Model code number	1XT1E	1XT4C
Transmission gear ratio	D range	2.349 - 0.394	
	Reverse	1.750	
	Final drive	5.407	
Recommended fluid		NISSAN CVT Fluid NS-2*1	
Fluid capacity	Liter (US qt., Imp qt)	7.3 (7-3/4, 6-3/8)	7.5 (7-7/8, 6-5/8)

CAUTION:

- Use only Genuine NISSAN CVT Fluid NS-2. Do not mix with other fluid.
- Using CVT fluid other than Genuine NISSAN CVT Fluid NS-2 will deteriorate in driveability and CVT durability, and may damage the CVT, which is not covered by the NISSAN new vehicle limited warranty.

*1: Refer to [MA-14, "MR20DE"](#).

Vehicle Speed When Shifting Gears

INFOID:000000004407318

Numerical value data are reference values.

Engine type	Throttle position	Shift pattern	Engine speed (rpm)	
			At 40 km/h (25 MPH)	At 60 km/h (37 MPH)
MR20DE	Full	"D" position	3,400 - 4,200	4,300 - 5,100
		Overdrive-off mode		
		"L" position		
	1/4	"D" position	1,400 - 2,200	1,600 - 2,400
		Overdrive-off mode	2,200 - 3,000	2,800 - 3,600
		"L" position	3,600 - 4,400	4,100 - 4,900
QR25DE	Full	"D" position	3,300 - 4,200	4,300 - 5,200
		Overdrive-off mode		
		"L" position		
	1/4	"D" position	1,300 - 3,100	1,400 - 3,400
		Overdrive-off mode	2,200 - 3,000	2,800 - 3,600
		"L" position	3,200 - 4,100	4,100 - 4,900

CAUTION:

Lock-up clutch is engaged when vehicle speed is approximately 18 km/h (11 MPH) to 90 km/h (56 MPH).

Stall Speed

INFOID:000000004407319

Engine	Stall speed
MR20DE	2,500 - 3,000 rpm
QR25DE	2,050 - 3,550 rpm

SERVICE DATA AND SPECIFICATIONS (SDS)

< SERVICE INFORMATION >

Line Pressure

INFOID:000000004407320

Engine speed	Line pressure kPa (kg/cm ² , psi)
	"R", "D", "L" positions
At idle	750 (7.65, 108.8)
At stall	5,700 (58.14, 826.5)*

*: Reference values

Solenoid Valves

INFOID:000000004407321

Name	Resistance (Approx.)	Terminal
Pressure control solenoid valve B (secondary pressure solenoid valve)	3.0 - 9.0 Ω	3
Pressure control solenoid valve A (line pressure solenoid valve)		2
Torque converter clutch solenoid valve		12
Lock-up select solenoid valve	17.0 - 38.0 Ω	13

CVT Fluid Temperature Sensor

INFOID:000000004407322

Name	Condition	CONSULT-III "DATA MONITOR" (Approx.)	Resistance (Approx.)
ATF TEMP SEN	20°C (68°F)	2.0 V	6.5 kΩ
	80°C (176°F)	1.0 V	0.9 kΩ

Primary Speed Sensor

INFOID:000000004407323

Name	Condition	Data (Approx.)
Primary speed sensor	When driving ["L" position, 20 km/h (12 MPH)].	890 Hz

Secondary Speed Sensor

INFOID:000000004407324

Name	Condition	Data (Approx.)
Secondary speed sensor	When driving ["D" position, 20 km/h (12 MPH)].	460 Hz

Removal and Installation

INFOID:000000004407325

Distance between end of converter housing and torque converter	14.4 mm (0.567 in)
--	--------------------