

CONTENTS

<b>MR20DE</b>		<b>WATER OUTLET AND WATER CONTROL VALVE</b> .....23	
<b>SERVICE INFORMATION</b> .....	3	Component .....	23
<b>PRECAUTIONS</b> .....	3	Removal and Installation .....	24
Precaution for Supplemental Restraint System (SRS) "AIR BAG" and "SEAT BELT PRE-TENSIONER" .....	3	<b>SERVICE DATA AND SPECIFICATIONS (SDS)</b> .....	27
Precaution Necessary for Steering Wheel Rotation After Battery Disconnect .....	3	Standard and Limit .....	27
Precaution for Liquid Gasket .....	4	<b>QR25DE</b>	
<b>PREPARATION</b> .....	5	<b>SERVICE INFORMATION</b> .....	28
Special Service Tool .....	5	<b>PRECAUTIONS</b> .....	28
Commercial Service Tool .....	5	Precaution for Supplemental Restraint System (SRS) "AIR BAG" and "SEAT BELT PRE-TENSIONER" .....	28
<b>OVERHEATING CAUSE ANALYSIS</b> .....	7	Precaution Necessary for Steering Wheel Rotation After Battery Disconnect .....	28
Troubleshooting Chart .....	7	Precaution for Liquid Gasket .....	29
<b>COOLING SYSTEM</b> .....	9	<b>PREPARATION</b> .....	30
Cooling Circuit .....	9	Special Service Tool .....	30
<b>ENGINE COOLANT</b> .....	11	Commercial Service Tool .....	30
Inspection .....	11	<b>OVERHEATING CAUSE ANALYSIS</b> .....	32
Changing Engine Coolant .....	12	Troubleshooting Chart .....	32
<b>RADIATOR</b> .....	15	<b>COOLING SYSTEM</b> .....	34
Component .....	15	Cooling Circuit .....	34
Removal and Installation .....	15	Schematic .....	36
<b>COOLING FAN</b> .....	17	<b>ENGINE COOLANT</b> .....	38
Component .....	17	Inspection .....	38
Removal and Installation .....	17	Changing Engine Coolant .....	39
Disassembly and Assembly .....	18	<b>RADIATOR</b> .....	43
<b>WATER PUMP</b> .....	19	Component .....	43
Component .....	19	Removal and Installation .....	43
Removal and Installation .....	19	<b>COOLING FAN</b> .....	45
<b>THERMOSTAT</b> .....	20	Component .....	45
Component .....	20	Removal and Installation .....	45
Removal and Installation .....	21		

Disassembly and Assembly .....	46	<b>WATER CONTROL VALVE .....</b>	<b>52</b>
<b>WATER PUMP .....</b>	<b>47</b>	Component .....	52
Component .....	47	Removal and Installation .....	53
Removal and Installation .....	47	<b>SERVICE DATA AND SPECIFICATIONS</b>	
<b>THERMOSTAT AND THERMOSTAT HOUS-</b>		<b>(SDS) .....</b>	<b>55</b>
<b>ING .....</b>	<b>49</b>	Capacity .....	55
Component .....	49	Thermostat .....	55
Removal and Installation .....	50	Water Control Valve .....	55
		Radiator .....	55

## SERVICE INFORMATION

### PRECAUTIONS

#### Precaution for Supplemental Restraint System (SRS) "AIR BAG" and "SEAT BELT PRE-TENSIONER"

INFOID:000000004777171

The Supplemental Restraint System such as "AIR BAG" and "SEAT BELT PRE-TENSIONER", used along with a front seat belt, helps to reduce the risk or severity of injury to the driver and front passenger for certain types of collision. This system includes seat belt switch inputs and dual stage front air bag modules. The SRS system uses the seat belt switches to determine the front air bag deployment, and may only deploy one front air bag, depending on the severity of a collision and whether the front occupants are belted or unbelted. Information necessary to service the system safely is included in the SRS and SB section of this Service Manual.

#### **WARNING:**

- **To avoid rendering the SRS inoperative, which could increase the risk of personal injury or death in the event of a collision which would result in air bag inflation, all maintenance must be performed by an authorized NISSAN/INFINITI dealer.**
- **Improper maintenance, including incorrect removal and installation of the SRS can lead to personal injury caused by unintentional activation of the system. For removal of Spiral Cable and Air Bag Module, see the SRS section.**
- **Do not use electrical test equipment on any circuit related to the SRS unless instructed to in this Service Manual. SRS wiring harnesses can be identified by yellow and/or orange harnesses or harness connectors.**
- **When working near the Airbag Diagnosis Sensor Unit or other Airbag System sensors with the Ignition ON or engine running, DO NOT use air or electric power tools or strike near the sensor(s) with a hammer. Heavy vibration could activate the sensor(s) and deploy the air bag(s), possibly causing serious injury.**
- **When using air or electric power tools or hammers, always switch the Ignition OFF, disconnect the battery, and wait at least 3 minutes before performing any service.**

#### Precaution Necessary for Steering Wheel Rotation After Battery Disconnect

INFOID:000000004406997

#### **NOTE:**

- This Procedure is applied only to models with Intelligent Key system and NATS (NISSAN ANTI-THEFT SYSTEM).
- Remove and install all control units after disconnecting both battery cables with the ignition knob in the "LOCK" position.
- Always use CONSULT-III to perform self-diagnosis as a part of each function inspection after finishing work. If DTC is detected, perform trouble diagnosis according to self-diagnostic results.

For models equipped with the Intelligent Key system and NATS, an electrically controlled steering lock mechanism is adopted on the key cylinder.

For this reason, if the battery is disconnected or if the battery is discharged, the steering wheel will lock and steering wheel rotation will become impossible.

If steering wheel rotation is required when battery power is interrupted, follow the procedure below before starting the repair operation.

#### OPERATION PROCEDURE

1. Connect both battery cables.

#### **NOTE:**

Supply power using jumper cables if battery is discharged.

2. Use the Intelligent Key or mechanical key to turn the ignition switch to the "ACC" position. At this time, the steering lock will be released.
3. Disconnect both battery cables. The steering lock will remain released and the steering wheel can be rotated.
4. Perform the necessary repair operation.
5. When the repair work is completed, return the ignition switch to the "LOCK" position before connecting the battery cables. (At this time, the steering lock mechanism will engage.)
6. Perform a self-diagnosis check of all control units using CONSULT-III.

# PRECAUTIONS

< SERVICE INFORMATION >

[MR20DE]

## Precaution for Liquid Gasket

INFOID:000000004406998

### REMOVAL OF LIQUID GASKET SEALING

- After removing nuts and bolts, separate the mating surface, using Tool and remove old liquid gasket sealing.

**Tool number** : KV10111100 (J-37228)

#### CAUTION:

**Be careful not to damage the mating surfaces.**

- Tap (1) Tool to insert it, and then slide (2) it by tapping on the side as shown.
- In areas where Tool is difficult to use, use plastic hammer to lightly tap the parts, to remove it.

#### CAUTION:

**If for some unavoidable reason suitable tool such as screwdriver is used, be careful not to damage the mating surfaces.**

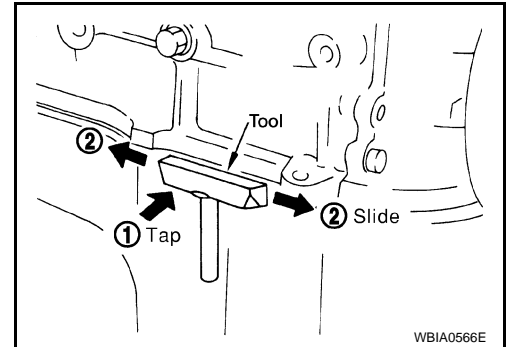

### LIQUID GASKET APPLICATION PROCEDURE

1. Remove old liquid gasket adhering to the liquid gasket application surface and the mating surface, using scraper.
  - Remove liquid gasket completely from the groove of the liquid gasket application surface, bolts, and bolt holes.
2. Thoroughly clean the mating surfaces and remove adhering moisture, grease and foreign materials.

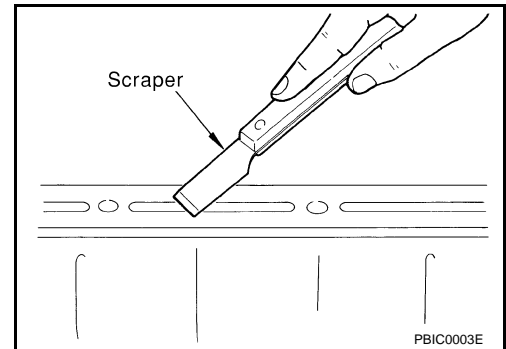

3. Attach liquid gasket tube to Tool.

**Tool number** : WS39930000 ( — )

**Use Genuine RTV Silicone Sealant or equivalent. Refer to GI-42. "Recommended Chemical Product and Sealant".**

4. Apply liquid gasket without breaks to the specified location with the specified dimensions.
  - If there is a groove for the liquid gasket application, apply liquid gasket to the groove.

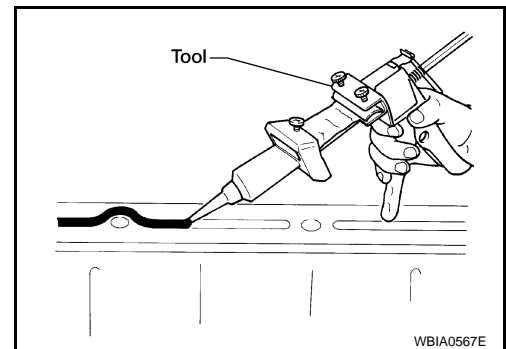

- As for the bolt holes, normally apply liquid gasket inside the holes. Occasionally, it should be applied outside the holes. Make sure to read the text of service manual.
- Within five minutes of liquid gasket application, install the mating component.
- If liquid gasket protrudes, wipe it off immediately.
- Do not retighten nuts or bolts after the installation.
- After 30 minutes or more have passed from the installation, fill engine oil and engine coolant.

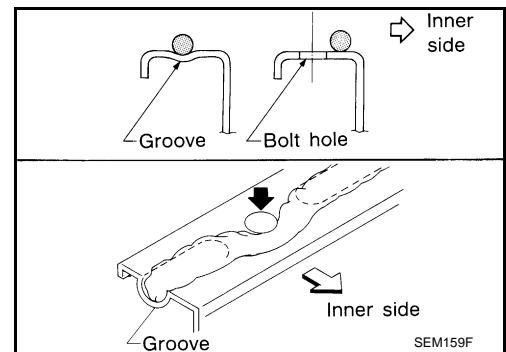

#### CAUTION:

**If there are specific instructions in this manual, observe them.**

# PREPARATION

< SERVICE INFORMATION >

[MR20DE]

## PREPARATION

### Special Service Tool

INFOID:000000004406999

The actual shapes of Kent-Moore tools may differ from those of special service tools illustrated here.

Tool number (Kent-Moore No.) Tool name	Description
WS39930000 ( — ) Tube pressure	Pressing the tube of liquid gasket
EG17650301 (J-33984-A) Radiator cap tester adapter	Adapting radiator cap tester to radiator cap and radiator filler neck <b>a: 28 (1.10) dia.</b> <b>b: 31.4 (1.236) dia.</b> <b>c: 41.3 (1.626) dia.</b> Unit: mm (in)
KV10111100 (J-37228) Seal cutter	Removing chain tensioner cover and water pump cover
KV991J0070 (J-45695) Coolant Refill Tool	Refilling engine cooling system
— (J-23688) Engine coolant refractometer	Checking concentration of ethylene glycol in engine coolant

### Commercial Service Tool

INFOID:000000004407000

# PREPARATION

< SERVICE INFORMATION >

[MR20DE]

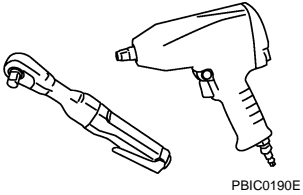
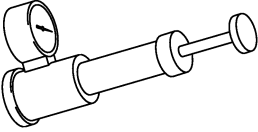
Tool name	Description
<p data-bbox="159 197 272 224">Power tool</p>  <p data-bbox="849 415 922 432">PBIC0190E</p>	<p data-bbox="1008 197 1260 224">Loosening bolts and nuts</p>
<p data-bbox="159 449 354 476">Radiator cap tester</p>  <p data-bbox="849 663 922 680">PBIC1982E</p>	<p data-bbox="1008 449 1357 476">Checking radiator and radiator cap</p>

# OVERHEATING CAUSE ANALYSIS

< SERVICE INFORMATION >

[MR20DE]

## OVERHEATING CAUSE ANALYSIS

### Troubleshooting Chart

INFOID:000000004407001

		Symptom	Check items	
Cooling system parts malfunction	Poor heat transfer	Water pump malfunction	Worn or loose drive belt	—
		Thermostat stuck closed	Thermostat	
		Damaged fins	Dust contamination or paper clogging	
			Physical damage	
		Clogged radiator cooling tube	Excess foreign material (rust, dirt, sand, etc.)	
	Reduced air flow	Cooling fan does not operate	Fan assembly	—
		High resistance to fan rotation		
		Damaged fan blades		
		Damaged radiator shroud	—	—
		Improper engine coolant mixture ratio	Engine coolant viscosity	—
		Poor engine coolant quality		—
	Insufficient engine coolant	Engine coolant leaks	Cooling hose	Loose clamp
				Cracked hose
			Water pump	Poor sealing
			Radiator cap	Loose
Poor sealing				
Radiator		O-ring for damage, deterioration or improper fitting		
		Cracked radiator tank		
		Cracked radiator core		
	Reservoir tank	Cracked reservoir tank		
Overflowing reservoir tank	Exhaust gas leaks into cooling system	Cylinder head deterioration		
		Cylinder head gasket deterioration		

A  
CO  
C  
D  
E  
F  
G  
H  
I  
J  
K  
L  
M  
N  
O  
P

# OVERHEATING CAUSE ANALYSIS

< SERVICE INFORMATION >

[MR20DE]

		Symptom		Check items	
Except cooling system parts malfunction	—	Overload on engine	Abusive driving	High engine rpm under no load	—
				Driving in low gear for extended time	
				Driving at extremely high speed	
			Power train system malfunction		
			Installed improper size wheels and tires		
			Dragging brakes		
	Blocked or restricted air flow	Blocked or restricted air flow	Blocked bumper	Installed front bumper fascia cover	—
			Blocked radiator grille	Mud contamination or paper clogging	
			Blocked radiator	Blocked air flow	
			Blocked condenser		
			Installed large fog lamp		



# COOLING SYSTEM

< SERVICE INFORMATION >

[MR20DE]

## COOLING SYSTEM

### Cooling Circuit

INFOID:000000004407002

A

CO

C

D

E

F

G

H

I

J

K

L

M

N

O

P

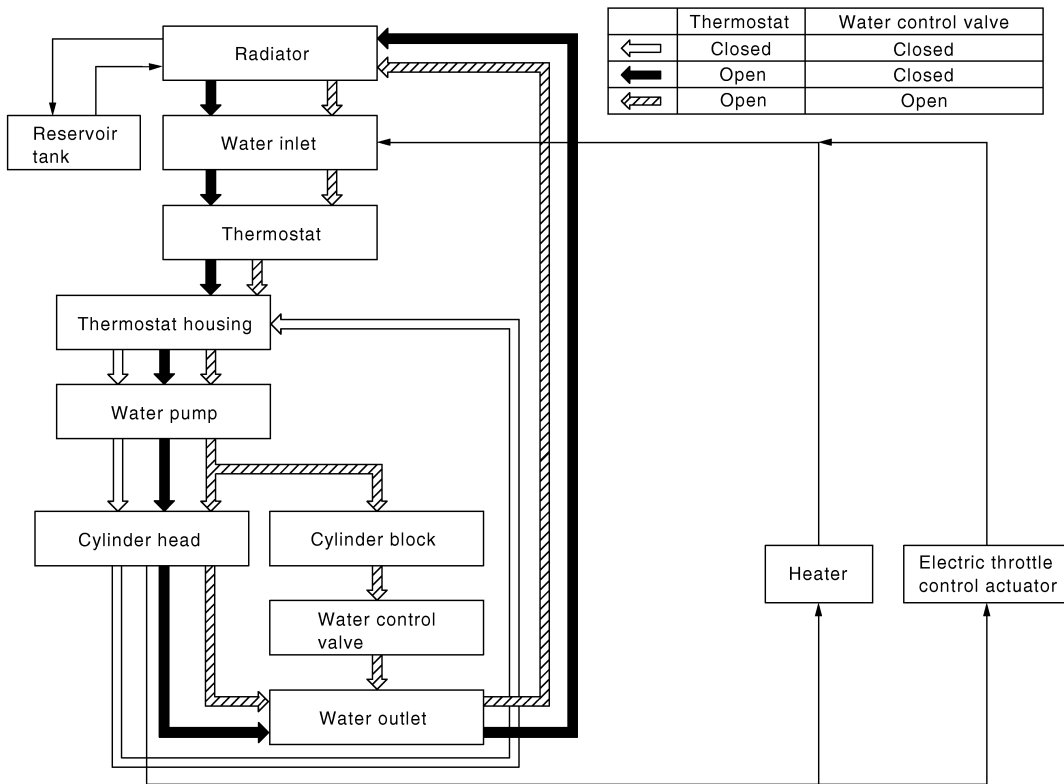
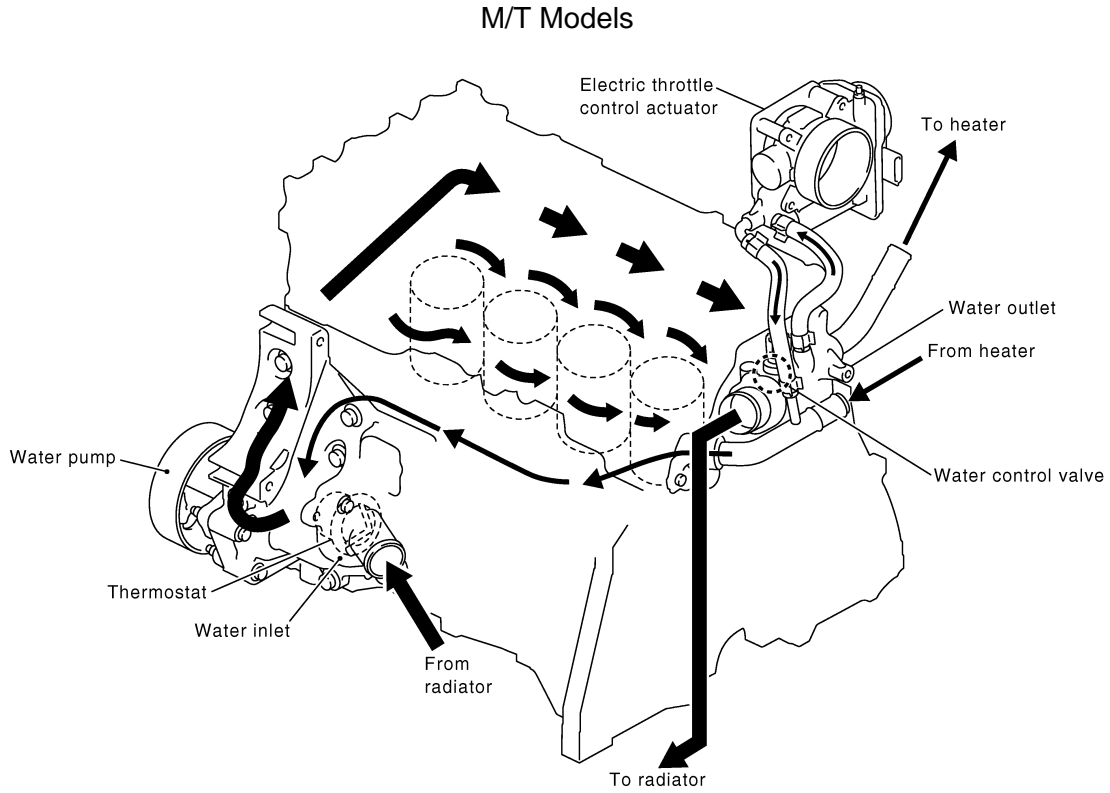

PBIC4719E

# COOLING SYSTEM

< SERVICE INFORMATION >

[MR20DE]

## CVT Models

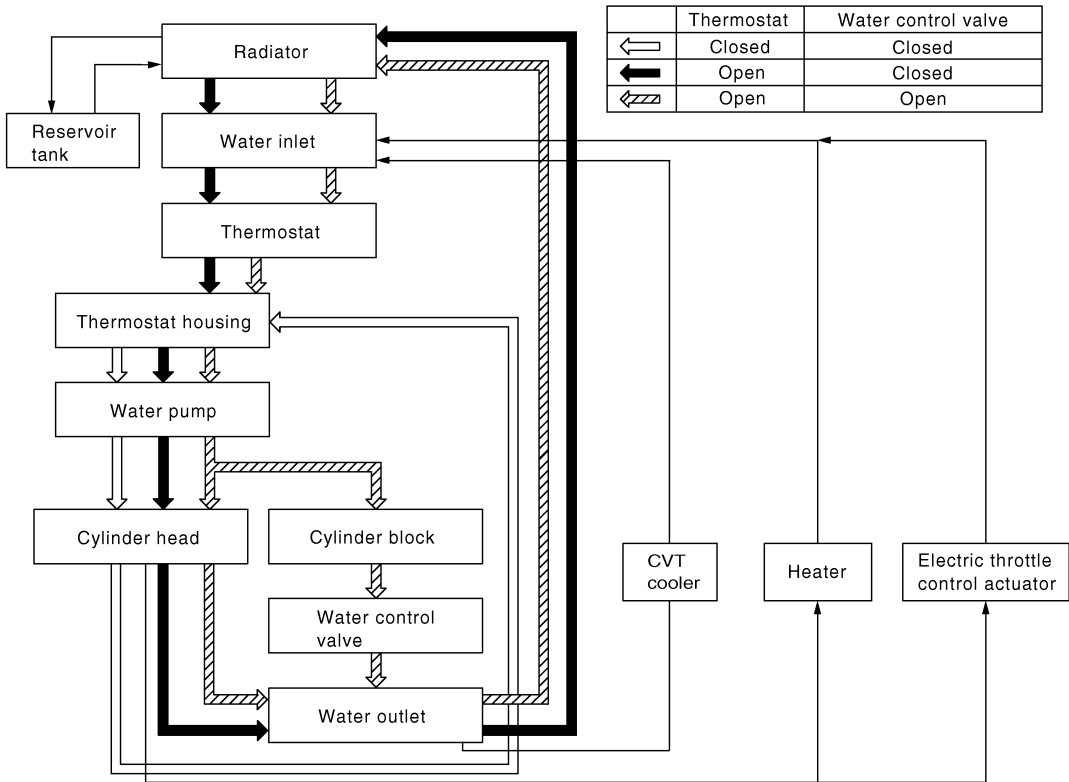
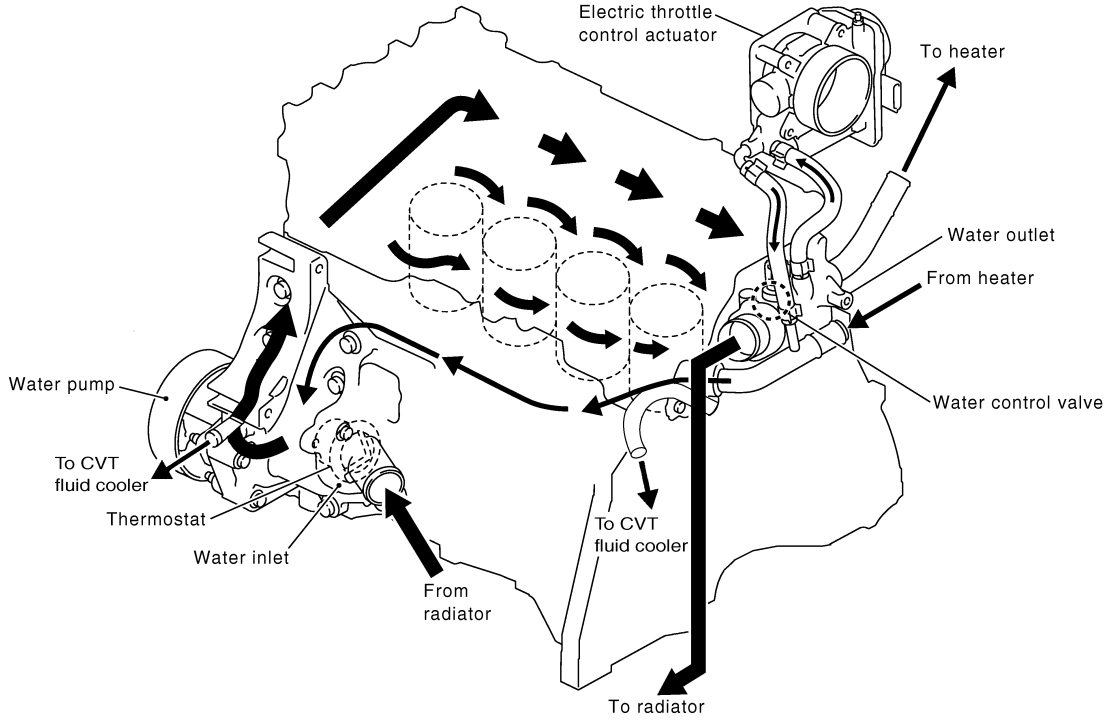

WBIA0815E

## ENGINE COOLANT

## Inspection

INFOID:000000004407003

**WARNING:**

- Never remove the radiator cap when the engine is hot. Serious burns could occur from high pressure fluid escaping from the radiator.
- Wrap a thick cloth around the cap. Slowly push down and turn it a quarter turn to allow built-up pressure to escape. Carefully remove the cap by pushing down and turning it all the way.

## CHECKING COOLING SYSTEM HOSES

Check hoses for the following:

- Improper attachment
- Leaks
- Cracks
- Damage
- Loose connections
- Chafing
- Deterioration

## CHECKING RESERVOIR LEVEL

- Check if the reservoir tank engine coolant level is within the MIN to MAX range when the engine is cool.
- Adjust the engine coolant level as necessary.

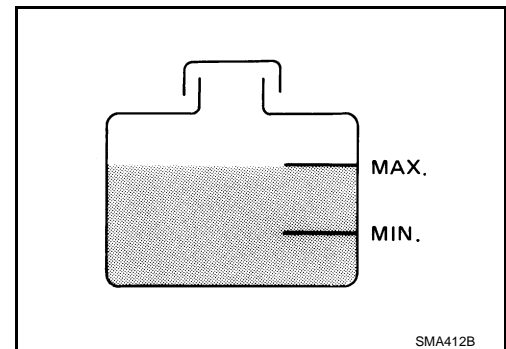

## CHECKING COOLING SYSTEM FOR LEAKS

To check for leaks, apply pressure to the cooling system using Tool.

**Tool number** : EG17650301 (J-33984-A)

**Testing pressure** : 157 kPa (1.6 kg/cm<sup>2</sup>, 23 psi)

**WARNING:**

Never remove the radiator cap when the engine is hot. Serious burns could occur from high pressure coolant escaping from the radiator.

**CAUTION:**

Higher pressure than specified may cause radiator damage.

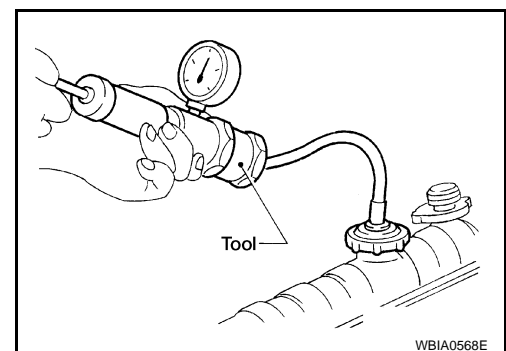

## CHECKING RADIATOR CAP

1. Inspect the radiator cap.
  - Replace the cap if the metal plunger cannot be seen around the edge of the black rubber gasket.
  - Replace the cap if deposits of waxy residue or other foreign material are on the black rubber gasket or the metal retainer.

**NOTE:**

Thoroughly wipe out the radiator filler neck to remove any waxy residue or foreign material.

# ENGINE COOLANT

[MR20DE]

## < SERVICE INFORMATION >

2. Pull the negative-pressure valve to open it and check that it closes completely when released.
  - Check that there is no dirt or damage on the valve seat of the radiator cap negative-pressure valve.
  - Check that there are no abnormalities in the opening and closing conditions of the negative-pressure valve.

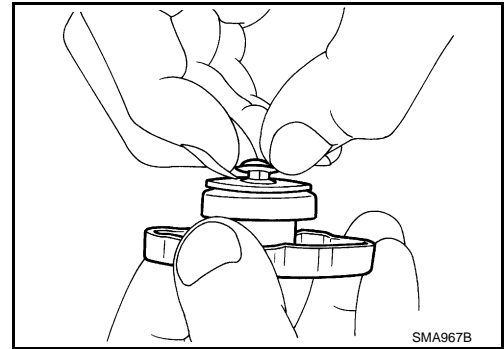

3. Check radiator cap relief pressure using Tool.

**Tool number : EG17650301 (J-33984-A)**

**Standard: 78 – 98 kPa (0.8 – 1.0 kg/cm<sup>2</sup>, 11 – 14 psi)**

**Limit: 59 kPa (0.6 kg/cm<sup>2</sup>, 9 psi)**

- When connecting the radiator cap to the tester, apply water or coolant to the cap seal surface.
- Replace the radiator cap if there is an abnormality in the negative-pressure valve, or if the open-valve pressure is outside of the standard values.

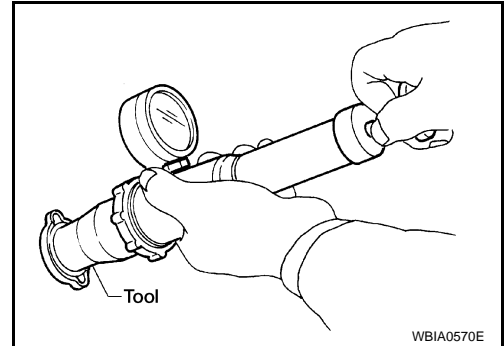

## CHECKING RADIATOR

Check radiator for mud or clogging. If necessary, clean radiator as follows.

- Be careful not to bend or damage the radiator fins.
  - When radiator is cleaned without removal, remove all surrounding parts such as cooling fan shroud and horns. Then tape the harness and electrical connectors to prevent water from entering.
1. Apply water by hose to the back side of the radiator core, with the hose pointed vertically downward.
  2. Apply water again to all radiator core surfaces once per minute.
  3. Stop washing if any stains no longer flow out from the radiator.
  4. Blow air into the back side of radiator core, with the air hose pointed vertically downward.
    - Use compressed air lower than 490 kPa (5 kg/cm<sup>2</sup>, 71 psi) and keep distance more than 30 cm (11.8 in).
  5. Blow air again into all the radiator core surfaces once per minute until no water sprays out.
  6. Check for leaks.

## Changing Engine Coolant

INFOID:000000004407004

### **WARNING:**

- To avoid being scalded, do not change the engine coolant when the engine is hot.
- Wrap a thick cloth around radiator cap and carefully remove the cap. First, turn the cap a quarter of a turn to release built-up pressure. Then push down and turn the cap all the way to remove.
- Be careful not to allow engine coolant to contact drive belt.

## DRAINING ENGINE COOLANT

1. Remove the engine undercover using power tool.

# ENGINE COOLANT

[MR20DE]

## < SERVICE INFORMATION >

- Open the radiator drain plug (1) at the bottom of the radiator, and remove the radiator filler cap. This is the only step required when partially draining the cooling system (radiator only).

• ← Front

### CAUTION:

- Perform this step when engine is cold.
- Do not spill engine coolant on drive belt.

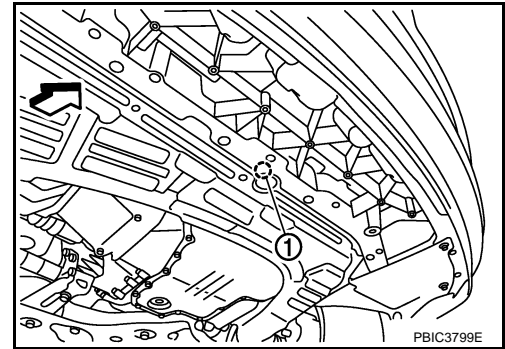

- Follow this step for heater core removal/replacement only. Disconnect the upper heater hose at the engine side and apply moderate air pressure [103.46 kPa (15 psi, 1.055 kg/cm<sup>2</sup>) maximum air pressure] into the hose for 30 seconds to blow the excess coolant out of the heater core.
- When draining all of the coolant in the system, remove the reservoir tank and drain the coolant, then clean the reservoir tank before installation.
- When draining all of the coolant in the system for engine removal or repair, open the drain plug on the cylinder block. Refer to [EM-74, "Component"](#).
- Check the drained engine coolant for contaminants such as rust, corrosion or discoloration. If the coolant is contaminated, flush the engine cooling system. Follow the "FLUSHING COOLING SYSTEM" procedure.

## REFILLING ENGINE COOLANT

- Install the radiator drain plug. Install the reservoir tank and cylinder block drain plug, if removed for a total system drain or for engine removal or repair.
  - The radiator must be completely empty of coolant and water.
  - Apply sealant to the threads of the cylinder block drain plugs. Use Genuine High Performance Thread Sealant or equivalent. Refer to [GI-42, "Recommended Chemical Product and Sealant"](#).

**Radiator drain plug** : Refer to [CO-15, "Component"](#).

**Cylinder block drain plug** : Refer to [EM-182, "Removal and Installation"](#).

- If disconnected, reattach the upper radiator hose at the engine side.
- Set the vehicle heater controls to the full HOT and heater ON position. Turn the vehicle ignition ON with the engine OFF as necessary to activate the heater mode.
- Install the Tool by installing the radiator cap adapter onto the radiator neck opening. Then attach the gauge body assembly with the refill tube and the venturi assembly to the radiator cap adapter.

**Tool number** : KV991J0070 (J-45695)

- Insert the refill hose into the coolant mixture container that is placed at floor level. Make sure the ball valve is in the closed position.
  - Use Genuine NISSAN Long Life Anti-freeze coolant or equivalent, mixed 50/50 with distilled water or demineralized water.Refer to [MA-16, "Anti-freeze Coolant Mixture Ratio"](#).

**Engine coolant capacity (with reservoir tank)** : Refer to [MA-14](#).

- Install an air hose to the venturi assembly, the air pressure must be within specification.

**Compressed air supply pressure** : 5.7 - 8.5 kPa (5.6 - 8.4 kg/cm<sup>2</sup>, 80 - 120 psi)

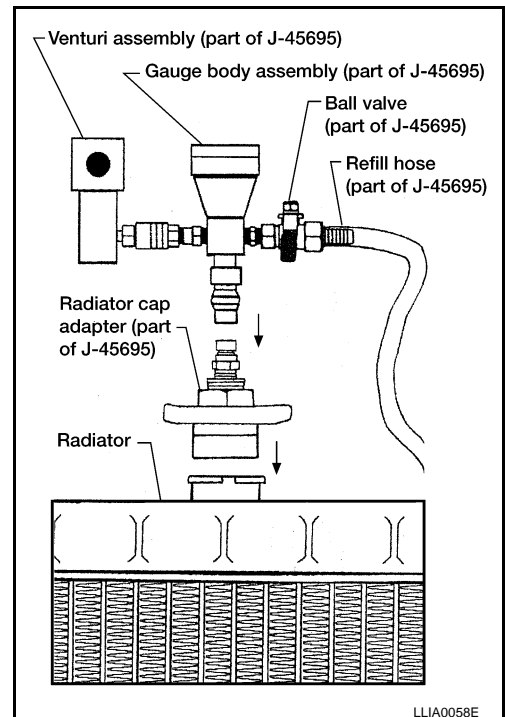

# ENGINE COOLANT

[MR20DE]

< SERVICE INFORMATION >

**CAUTION:**

**The compressed air supply must be equipped with an air dryer.**

7. The vacuum gauge will begin to rise and there will be an audible hissing noise. During this process open the ball valve on the refill hose slightly. Coolant will be visible rising in the refill hose. Once the refill hose is full of coolant, close the ball valve. This will purge any air trapped in the refill hose.
8. Continue to draw the vacuum until the gauge reaches 28 inches of vacuum. The gauge may not reach 28 inches in high altitude locations, use the vacuum specifications below based on the altitude above sea level.

Altitude above sea level	Vacuum gauge reading
0 - 100 m (328 ft)	: 28 inches of vacuum
300 m (984 ft)	: 27 inches of vacuum
500 m (1,641 ft)	: 26 inches of vacuum
1,000 m (3,281 ft)	: 24 - 25 inches of vacuum

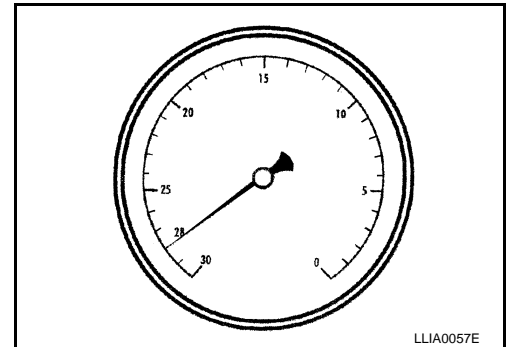

9. When the vacuum gauge has reached the specified amount, disconnect the air hose and wait 20 seconds to see if the system loses any vacuum. If the vacuum level drops, perform any necessary repairs to the system and repeat steps 6 - 8 to bring the vacuum to the specified amount. Recheck for any leaks.
10. Place the coolant container (with the refill hose inserted) at the same level as the top of the radiator. Then open the ball valve on the refill hose so the coolant will be drawn up to fill the cooling system. The cooling system is full when the vacuum gauge reads zero.

**CAUTION:**

**Do not allow the coolant container to get too low when filling, to avoid air from being drawn into the cooling system.**

11. Remove the Tool from the radiator neck opening.
12. Fill the cooling system reservoir tank to the specified level and install the radiator cap. Run the engine to warm up the cooling system and top up the system as necessary.

## FLUSHING COOLING SYSTEM

1. Fill radiator and reservoir tank with water and reinstall radiator cap.
2. Run engine until it reaches normal operating temperature.
3. Rev the engine two or three times under no-load.
4. Stop the engine and wait until it cools down.
5. Drain water from the cooling system.
6. Repeat steps 1 through 5 until clear water begins to drain from the radiator.

# RADIATOR

< SERVICE INFORMATION >

[MR20DE]

## RADIATOR

### Component

INFOID:000000004407005

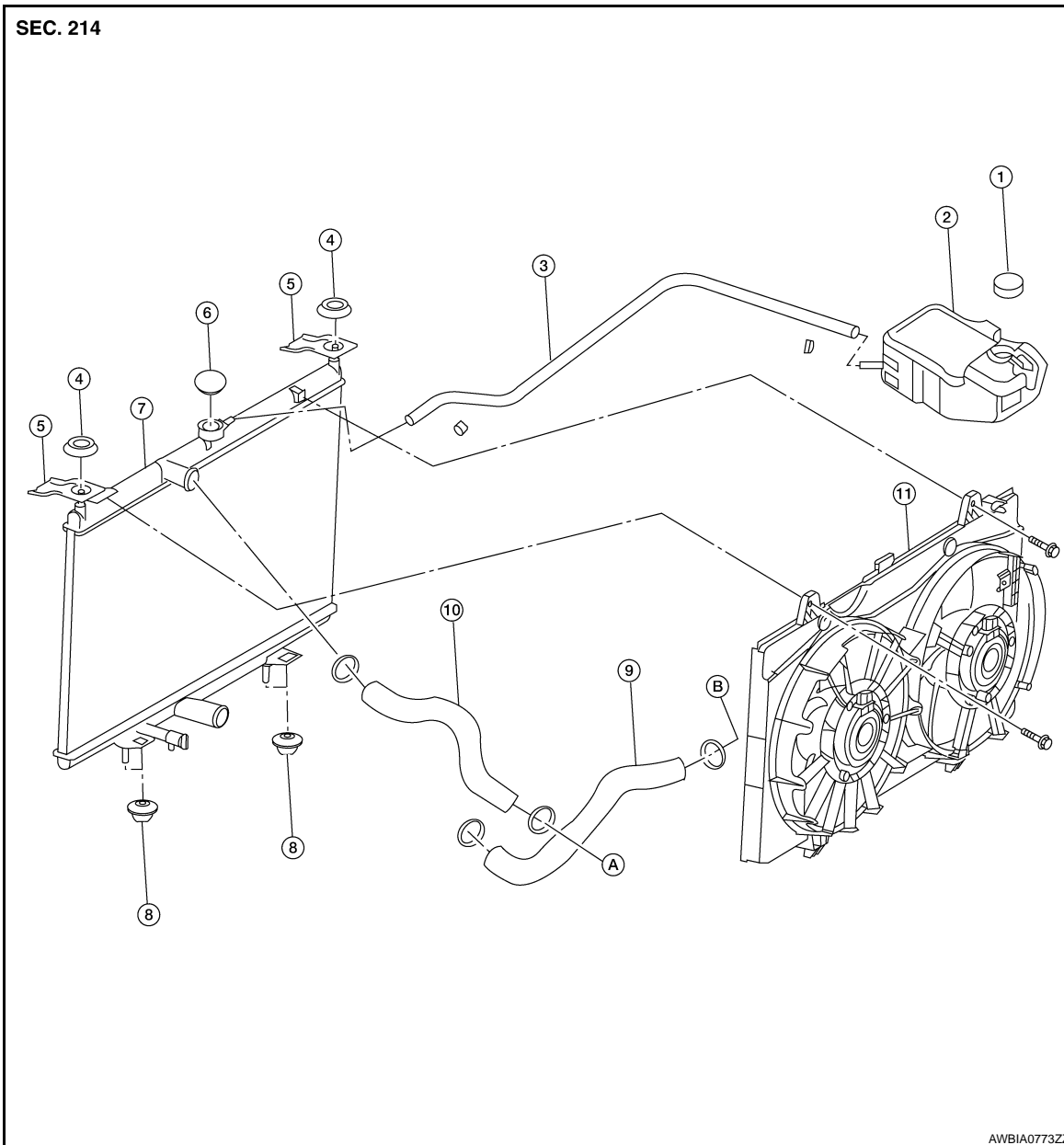

- |                            |                            |                          |
|----------------------------|----------------------------|--------------------------|
| 1. Reservoir tank cap      | 2. Reservoir tank          | 3. Reservoir tank hose   |
| 4. Mounting rubber (upper) | 5. Radiator upper mounts   | 6. Radiator cap          |
| 7. Radiator                | 8. Mounting rubber (lower) | 9. Radiator hose (lower) |
| 10. Radiator hose (upper)  | 11. Cooling fan assembly   | A. To water outlet       |
| B. To water inlet          |                            |                          |

### Removal and Installation

INFOID:000000004407006

#### **WARNING:**

Do not remove radiator cap when the engine is hot. Serious burns could occur from high-pressure engine coolant escaping from the radiator. Wrap a thick cloth around the cap. Slowly turn it a quarter turn to release built-up pressure. Carefully remove the radiator cap by turning it all the way.

#### REMOVAL

# RADIATOR

[MR20DE]

## < SERVICE INFORMATION >

1. Drain engine coolant from the radiator. Refer to [CO-12. "Changing Engine Coolant"](#).  
**CAUTION:**
  - Perform this step when engine is cold.
  - Do not spill engine coolant on drive belt.
2. Remove air duct (inlet). Refer to [EM-16](#).
3. Disconnect the reservoir tank hose.
4. Remove radiator hoses (upper and lower).
5. Disconnect harness connectors from fan motors, and position harness aside.
6. Remove the cooling fan assembly to radiator bolts and remove cooling fan assembly
7. Remove radiator upper mounts.
8. Move the radiator assembly to the rearward direction of vehicle, and then lift it upward to remove.

### **CAUTION:**

**Do not damage or scratch A/C condenser if equipped and radiator core when removing.**

## INSPECTION AFTER REMOVAL

Inspect radiator for leaks as follows:

- Apply pressure using Tool.

**Specified pressure value** : 157 kPa (1.6 kg/cm<sup>2</sup>, 23 psi)

**Tool number** : EG17650301 (J-33984-A)

### **WARNING:**

**To prevent the risk of the hose coming undone while under pressure, securely fasten it down with a hose clamp.**

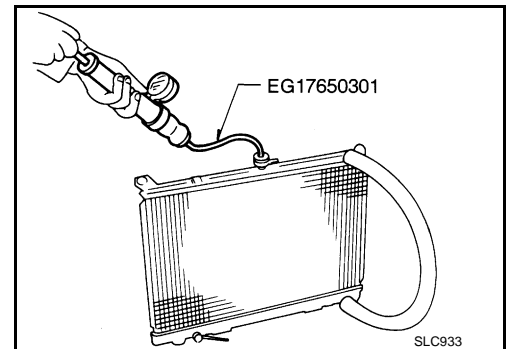

- Check for leakage.

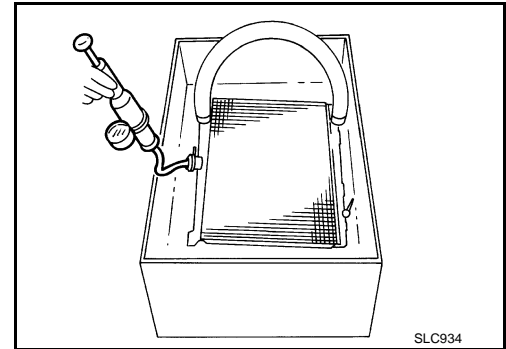

## INSTALLATION

Installation is in the reverse order of removal.

### **CAUTION:**

**Do not damage or scratch A/C condenser if equipped and radiator core when installing.**

## INSPECTION AFTER INSTALLATION

- Check for leaks of engine coolant. Refer to [CO-11. "Inspection"](#).
- Start and warm up engine. Visually check if there is no leaks of engine coolant and CVT fluid if equipped. Refer to [CVT-15](#).



## COOLING FAN

### Component

INFOID:000000004407011

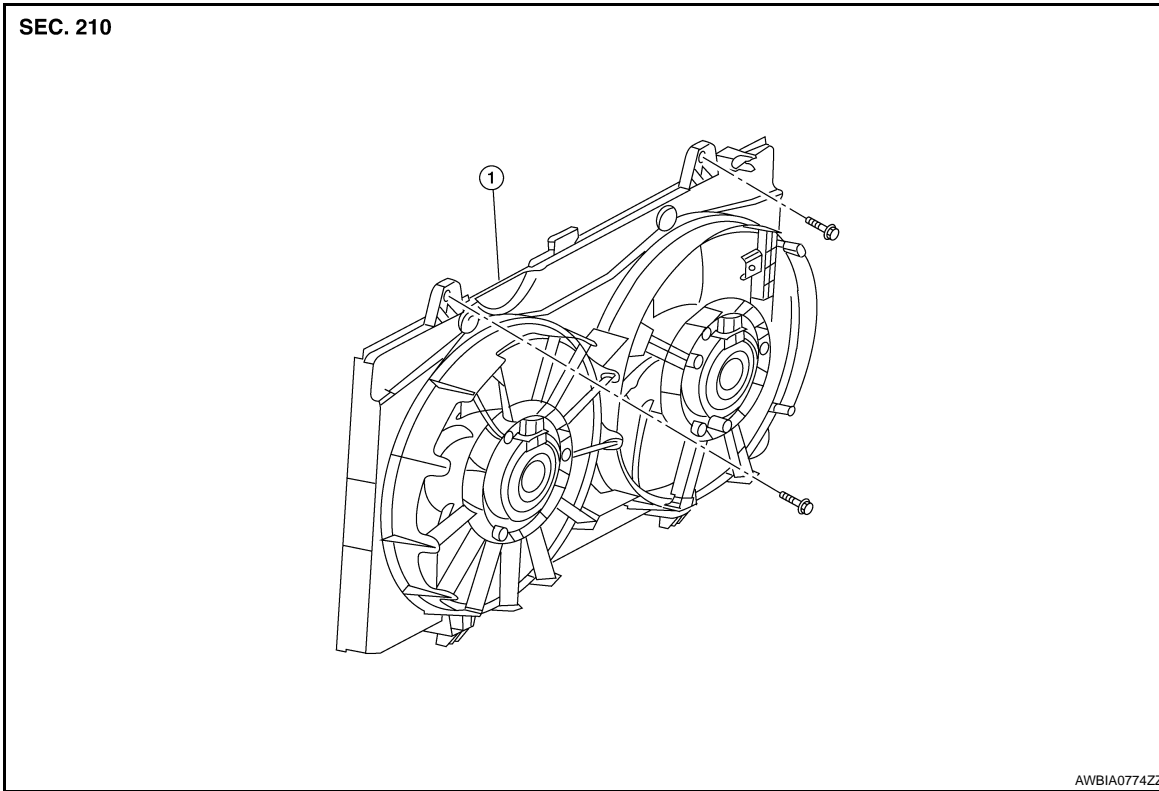

1. Cooling fan assembly

### Removal and Installation

INFOID:000000004407012

**WARNING:**

**Never remove the radiator cap when the engine is hot. Serious burns could occur from high pressure coolant escaping from the radiator.**

#### REMOVAL

1. Partially drain engine coolant from radiator. Refer to [CO-12, "Changing Engine Coolant"](#).

**CAUTION:**

- Perform this step when engine is cold.
- Do not spill engine coolant on drive belt.

2. Remove air duct (inlet). Refer to [EM-16](#).
3. Disconnect radiator hose (upper) at radiator side. Refer to [CO-15](#).
4. Disconnect harness connectors from fan motor, and position harness aside.
5. Remove cooling fan assembly.

**CAUTION:**

**Be careful not to damage or scratch the radiator core.**

#### INSTALLATION

Installation is in the reverse order of removal.

- Cooling fans are controlled by ECM. For details, refer to [EC-426](#).

**CAUTION:**

**Be careful not to damage or scratch the radiator core.**

# COOLING FAN

< SERVICE INFORMATION >

[MR20DE]

## Disassembly and Assembly

INFOID:000000004777161

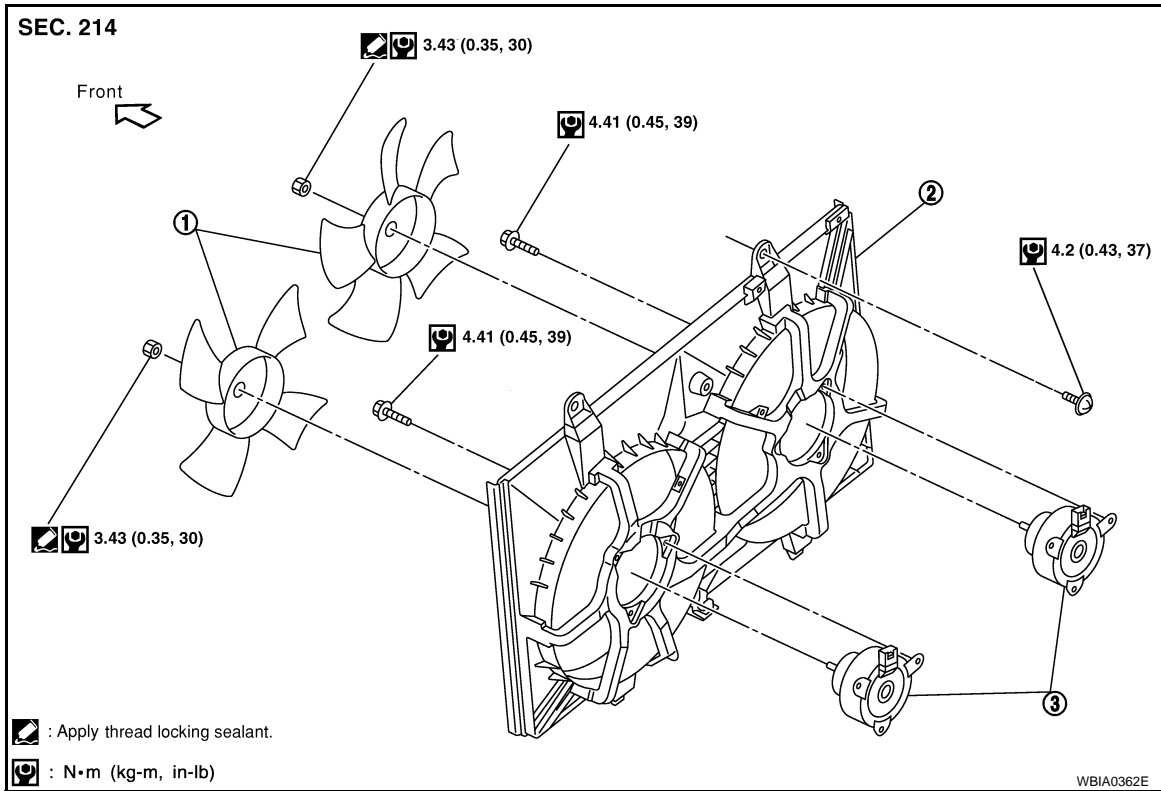

1. Fan blade

2. Fan shroud

3. Fan motor

### DISASSEMBLY

1. Remove fans from fan motors.
2. Remove fan motors from fan shroud.

### ASSEMBLY

Assembly is in the reverse order of disassembly.

# WATER PUMP

< SERVICE INFORMATION >

[MR20DE]

## WATER PUMP

### Component

INFOID:000000004407009

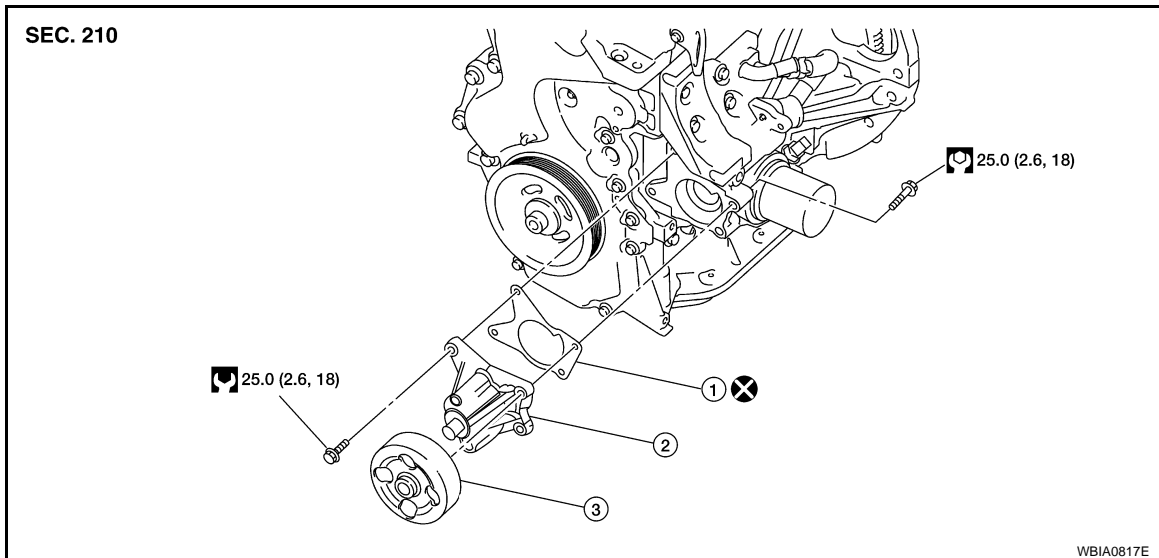

1. Gasket

2. Water pump

3. Pulley

### Removal and Installation

INFOID:000000004407010

#### **WARNING:**

Never remove the radiator cap when the engine is hot. Serious burns could occur from high pressure engine coolant escaping from the radiator.

#### REMOVAL

1. Drain engine coolant from the radiator. Refer to [CO-12, "Changing Engine Coolant"](#).

#### **CAUTION:**

Perform this step when the engine is cold.

2. Remove drive belt auto-tensioner. Refer to [EM-13, "Removal and Installation"](#).
3. Remove water pump.

#### **CAUTION:**

- Handle the water pump vane so that it does not contact any other parts.
- Water pump cannot be disassembled and should be replaced as an assembly.

#### INSPECTION AFTER REMOVAL

- Visually check that there is no significant dirt or rusting on the water pump body and vane (A).
- Make sure that there is no looseness in the vane shaft, and that it turns smoothly when rotated by hand.
- Replace water pump, if necessary.

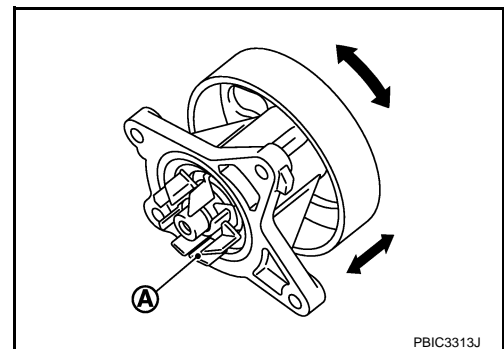

#### INSTALLATION

Installation is in the reverse order of removal.

#### INSPECTION AFTER INSTALLATION

- Check for leaks of engine coolant. Refer to [CO-11, "Inspection"](#).
- Start and warm up the engine. Visually check for leaks of engine coolant.

# THERMOSTAT

< SERVICE INFORMATION >

[MR20DE]

## THERMOSTAT

Component

INFOID:000000004407013

### M/T Models

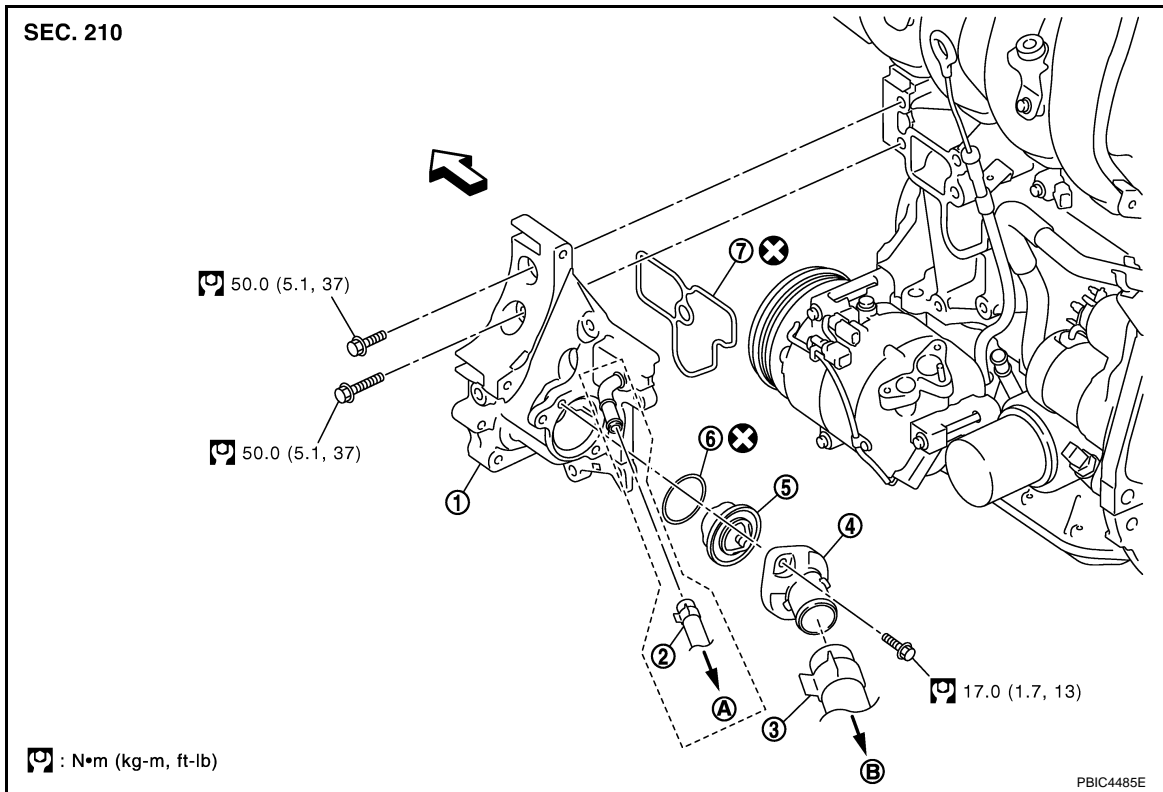

- |                       |  |                          |
|-----------------------|--|--------------------------|
| 1. Thermostat housing | 2. Water hose (models with oil cooler) | 3. Radiator hose (lower) |
| 4. Water inlet        | 5. Thermostat                          | 6. Rubber ring           |
| 7. Gasket             | A. To oil cooler                       | B. To radiator           |
- ← Engine front

### CVT Models

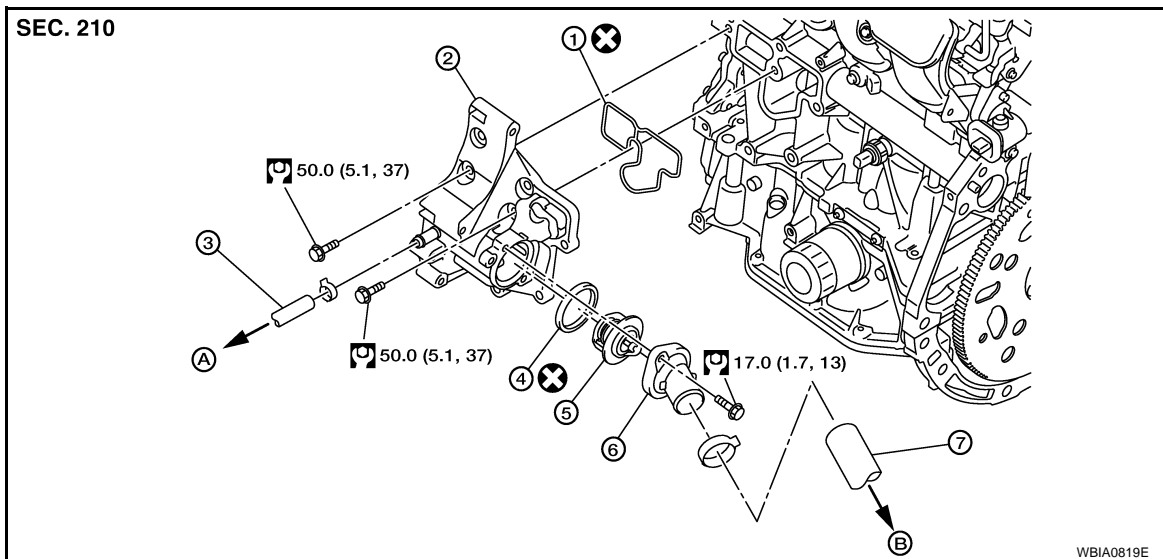

- |                |                       |                            |
|----------------|-----------------------|----------------------------|
| 1. Gasket      | 2. Thermostat housing | 3. Water hose (CVT models) |
| 4. Rubber ring | 5. Thermostat         | 6. Water inlet             |

# THERMOSTAT

< SERVICE INFORMATION >

[MR20DE]

7. Radiator hose (lower)

A. To CVT fluid cooler

B. To radiator

⇐ Engine front

## Removal and Installation

INFOID:000000004407014

### WARNING:

Never remove the radiator cap when the engine is hot. Serious burns could occur from high pressure engine coolant escaping from the radiator.

### REMOVAL

#### CAUTION:

Perform when the engine is cold.

1. Drain engine coolant from the radiator. Refer to [CO-12. "Changing Engine Coolant"](#).
2. Remove front air duct. Refer to [EM-16. "Removal and Installation"](#).
3. Disconnect radiator hose (lower) and remove water inlet.
4. Remove thermostat.
5. Remove thermostat housing, if necessary.

### INSPECTION AFTER REMOVAL

- Place a thread (A) so that it is caught in the valves of thermostat (1). Immerse fully in a container (B) filled with water. Heat while stirring.
- The valve opening temperature is the temperature at which the valve opens and the thermostat falls from the thread.
- Continue heating. Check the full-open valve lift amount.

#### NOTE:

The full-open valve lift amount standard temperature for the thermostat is the reference value.

- After checking the full-open valve lift amount, lower the water temperature and check the valve closing temperature.

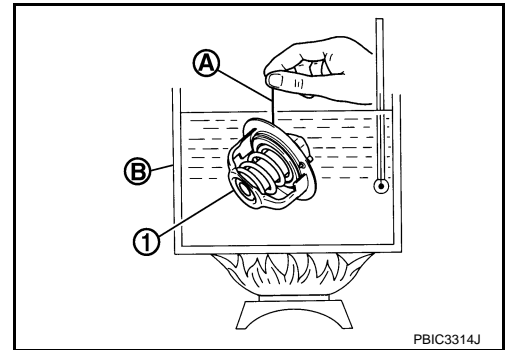

Items	Thermostat
Valve opening temperature	80.5 - 83.5°C (177 - 182°F)
Full-open valve lift amount	More than 8 mm/ 95°C (0.315 in/ 203°F)
Valve closing temperature	77°C (171°F)

- If out of the specification, replace thermostat.

### INSTALLATION

Installation is in the reverse order of removal.

Thermostat

#### CAUTION:

Replace the rubber ring with a new one.

- Install thermostat while making rubber ring (1) groove fit to thermostat flange (A) around the whole circumference.

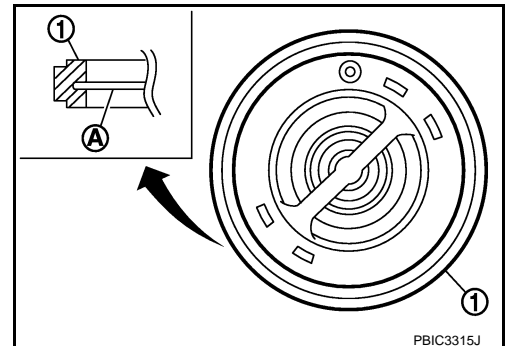

# THERMOSTAT

[MR20DE]

## < SERVICE INFORMATION >

- Install thermostat (1) into the thermostat housing (2) with jiggle valve (A) facing upwards.

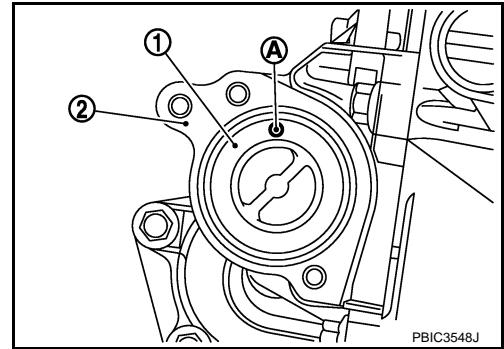

Thermostat Housing

### **CAUTION:**

**Replace the rubber ring with a new one.**

- Securely insert the rubber ring into the mating groove of thermostat housing and install it.
- Install the thermostat housing to the cylinder block without displacing the gasket from the gasket position.

### INSPECTION AFTER INSTALLATION

- Check for leaks of engine coolant. Refer to [CO-11, "Inspection"](#).
- Start and warm up the engine. Visually check for engine coolant leaks.

# WATER OUTLET AND WATER CONTROL VALVE

< SERVICE INFORMATION >

[MR20DE]

## WATER OUTLET AND WATER CONTROL VALVE

Component

INFOID:000000004407015

M/T Models

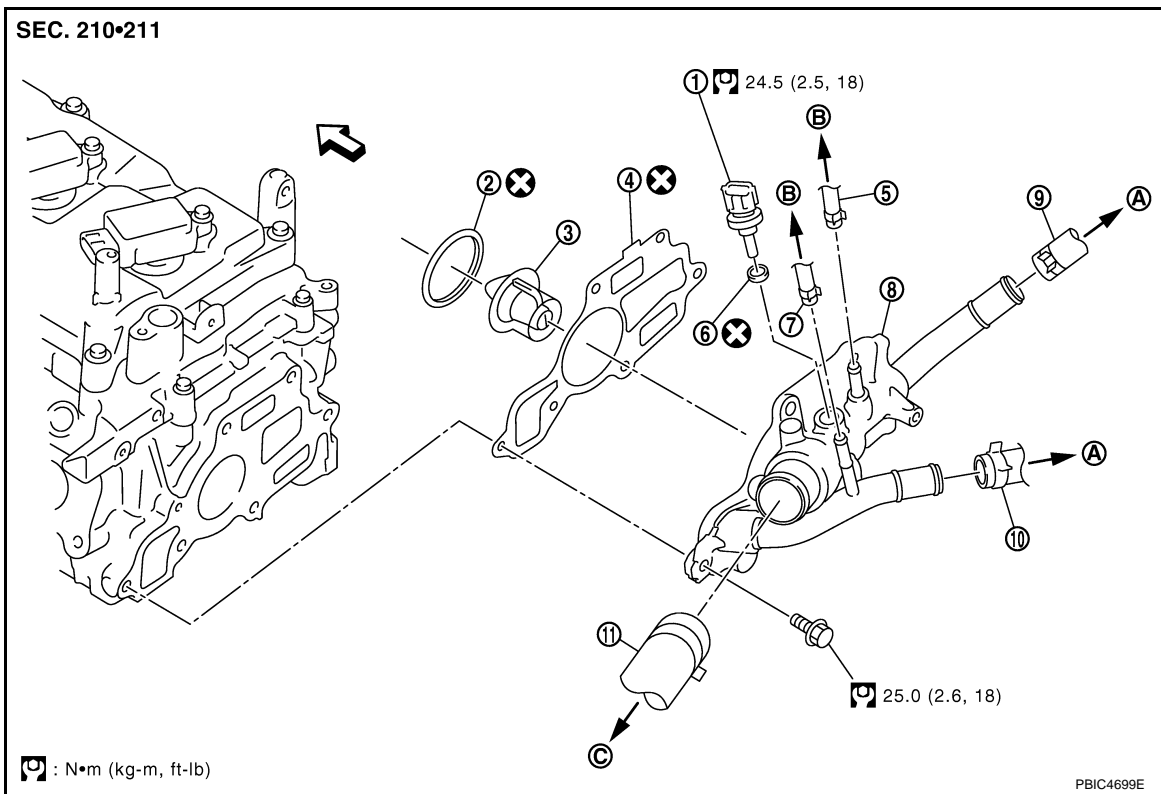

- |                                      |  |                        |
|--------------------------------------|--|------------------------|
| 1. Engine coolant temperature sensor | 2. Rubber ring                           | 3. Water control valve |
| 4. Gasket                            | 5. Water hose                            | 6. Gasket              |
| 7. Water hose                        | 8. Water outlet                          | 9. Heater hose         |
| 10. Heater hose                      | 11. Radiator hose (upper)                | ⇐ Front                |
| A. To heater                         | B. To electric throttle control actuator | C. To radiator         |

# WATER OUTLET AND WATER CONTROL VALVE

< SERVICE INFORMATION >

[MR20DE]

CVT Models

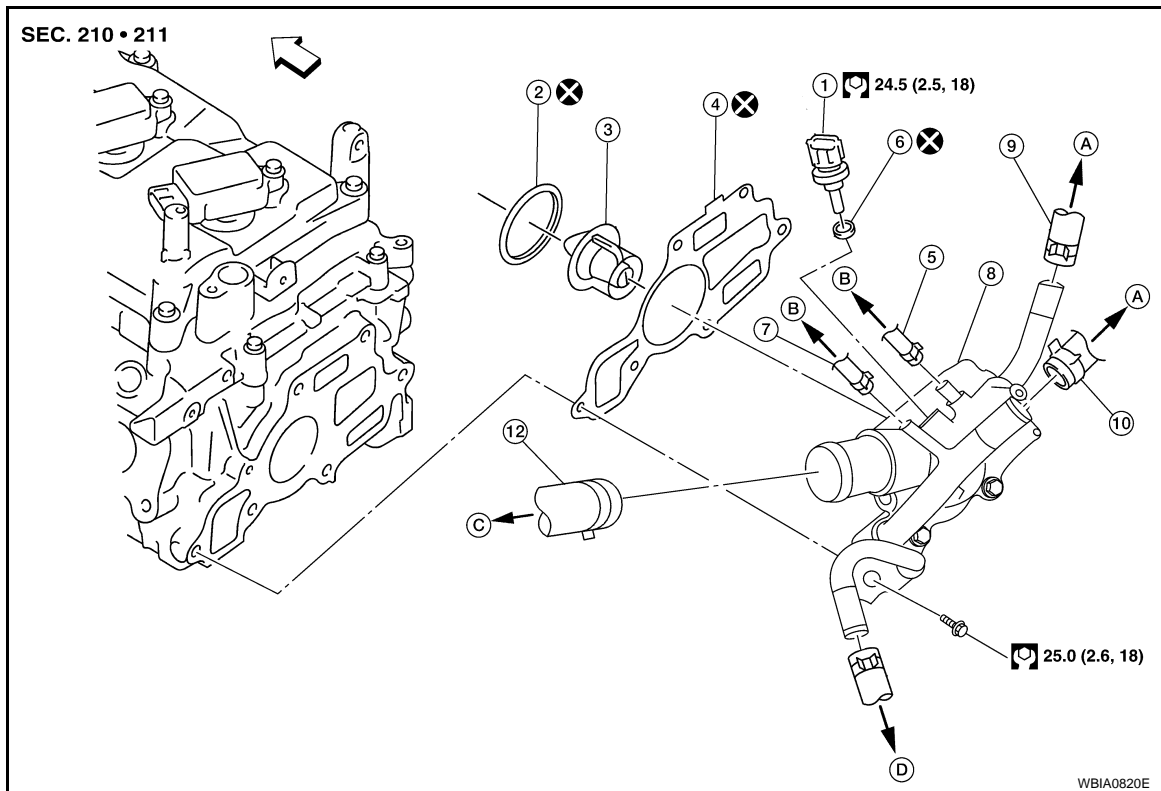

- |                                      |                                   |  |
|--------------------------------------|-----------------------------------|--|
| 1. Engine coolant temperature sensor | 2. Rubber ring                    | 3. Water control valve                   |
| 4. Gasket                            | 5. Water hose                     | 6. Gasket                                |
| 7. Water hose                        | 8. Water outlet                   | 9. Heater hose                           |
| 10. Heater hose                      | 11. Water hose (CVT fluid cooler) | 12. Radiator hose (upper)                |
| ⇐ Front                              | A. To heater                      | B. To electric throttle control actuator |
| C. To radiator                       | D. To CVT fluid cooler            |  |

## Removal and Installation

INFOID:000000004407016

### **WARNING:**

Never remove the radiator cap when the engine is hot. Serious burns could occur from high pressure engine coolant escaping from the radiator.

### REMOVAL

#### **CAUTION:**

Perform when the engine is cold.

1. Drain engine coolant from the radiator. Refer to [CO-12. "Changing Engine Coolant"](#).
2. Remove air cleaner and air duct assembly. Refer to [EM-16](#).
3. Remove radiator hose (upper). Refer to [CO-15](#).
4. Remove heater hoses and water hoses.
5. Remove water outlet.
6. Remove water control valve.
7. Remove engine coolant temperature switch, if necessary.

#### **CAUTION:**

- Handle carefully to avoid any shock to engine coolant temperature switch.
- Replace the gaskets and rubber rings with a new ones.

### INSPECTION AFTER REMOVAL



# WATER OUTLET AND WATER CONTROL VALVE

[MR20DE]

## < SERVICE INFORMATION >

- Place a thread (A) so that it is caught in the valve of the water control valve (1). Immerse fully in a container (B) filled with water. Heat while stirring.
- The valve opening temperature is the temperature at which the water control valve opens and falls from the thread.
- Continue heating. Check the full-open valve lift amount.

### NOTE:

The full-open valve lift amount standard temperature for the water control valve is the reference value.

- After checking the full-open valve lift amount, lower the water temperature and check the valve closing temperature.

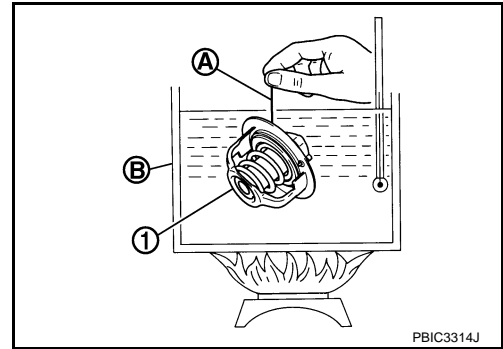

Items	Water control valve
Valve opening temperature	93.5 - 96.5°C (200 - 206°F)
Full-open valve lift amount	More than 8 mm/ 108°C (0.315 in/ 226°F)
Valve closing temperature	90°C (194°F)

- If out of the specification, replace water control valve.

## INSTALLATION

Installation is in the reverse order of removal.

Water Control Valve

### CAUTION:

**Replace the rubber ring with a new one.**

- Install water control valve while making rubber ring (1) groove fit to water control valve flange (A) around the whole circumference.

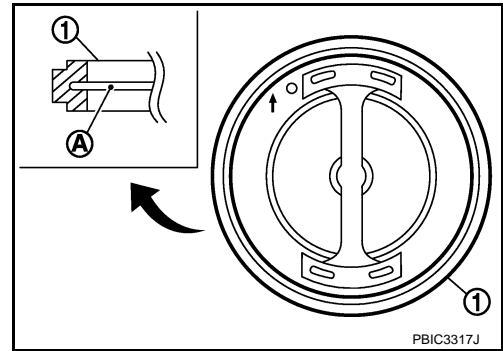

- While the mark (A) points to up, install water control valve (2) with frame center (B) facing straight upward into water outlet (1).

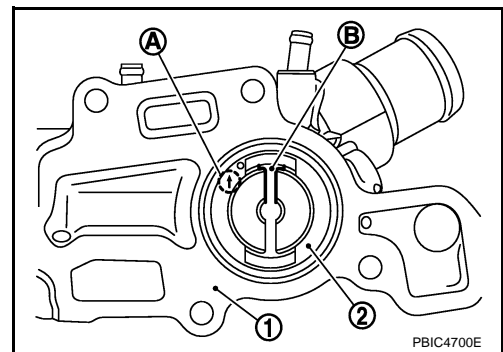

Water Outlet

Install the water control valve to the cylinder head without displacing the valve from the valve position.

Water Hoses (M/T Models)

# WATER OUTLET AND WATER CONTROL VALVE

[MR20DE]

## < SERVICE INFORMATION >

Install water hoses (3),(5) as shown.

- Electric throttle control actuator (1)
- Clamp (2)
- Water outlet (4)
- Paint mark (A)
- Clamp shall not interfere with the bulged area (B)
- ⇨: Engine front

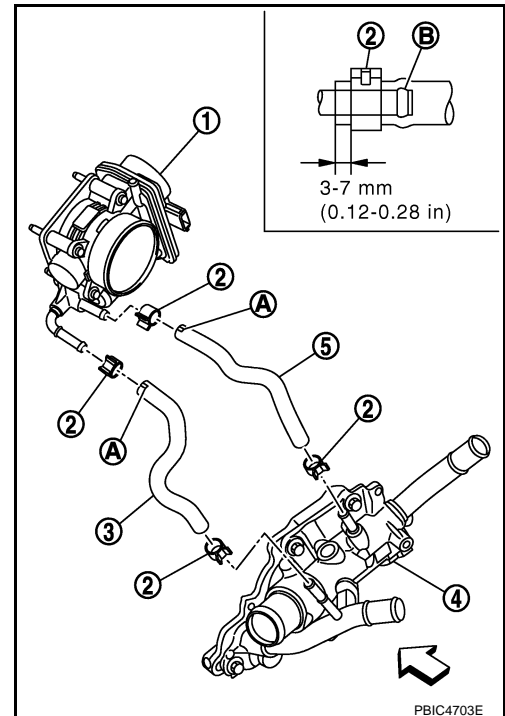

## Water Hoses (CVT Models)

Install water hoses (3),(5) as shown.

- Electric throttle control actuator (1)
- Clamp (2)
- Water outlet (4)
- Paint mark (A)
- Clamp shall not interfere with the bulged area (B)
- ⇨: Engine front

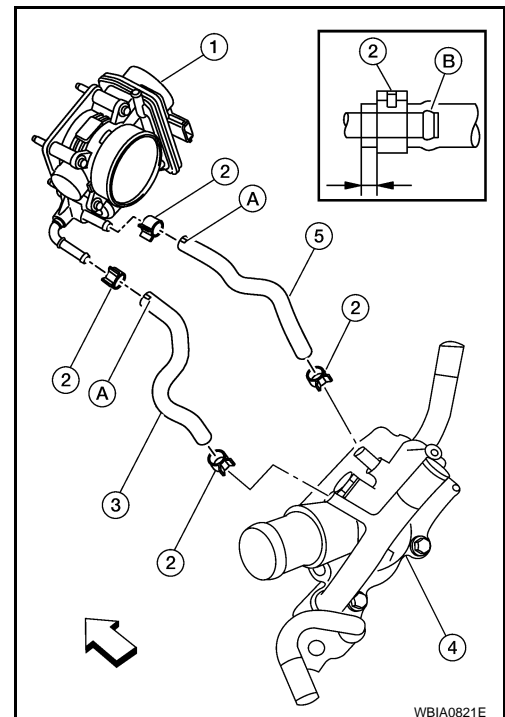

## INSPECTION AFTER INSTALLATION

- Check for leaks of engine coolant. Refer to [CO-11, "Inspection"](#).
- Start and warm up the engine. Visually check if there is no leaks of engine coolant.

# SERVICE DATA AND SPECIFICATIONS (SDS)

< SERVICE INFORMATION >

[MR20DE]

## SERVICE DATA AND SPECIFICATIONS (SDS)

### Standard and Limit

INFOID:000000004407017

### CAPACITY

Unit: ℓ (US qt, Imp qt)

Engine coolant capacity (with reservoir tank at MAX level)	Approx. 7.0 (7 3/8, 6 1/8)
--	----------------------------

### THERMOSTAT

Valve opening temperature	80.5 - 83.5°C (177 - 182°F)
Full-open valve lift amount	More than 8 mm/ 95°C (0.315 in/ 203°F)
Valve closing temperature	77°C (171°F)

### WATER CONTROL VALVE

Valve opening temperature	93.5 - 96.5°C (200 - 206°F)
Full-open valve lift amount	More than 8 mm/ 108°C (0.315 in/ 226°F)
Valve closing temperature	90°C (194°F)

### RADIATOR

Unit: kPa (kg / cm<sup>2</sup> , psi)

Cap relief pressure	Standard	78 - 98 (0.8 - 1.0, 11 - 14)
	Limit	59 (0.6, 9)
Leakage test pressure		157 (1.6, 23)

A  
CO  
C  
D  
E  
F  
G  
H  
I  
J  
K  
L  
M  
N  
O  
P

## SERVICE INFORMATION

### PRECAUTIONS

#### Precaution for Supplemental Restraint System (SRS) "AIR BAG" and "SEAT BELT PRE-TENSIONER"

INFOID:000000004777172

The Supplemental Restraint System such as "AIR BAG" and "SEAT BELT PRE-TENSIONER", used along with a front seat belt, helps to reduce the risk or severity of injury to the driver and front passenger for certain types of collision. This system includes seat belt switch inputs and dual stage front air bag modules. The SRS system uses the seat belt switches to determine the front air bag deployment, and may only deploy one front air bag, depending on the severity of a collision and whether the front occupants are belted or unbelted. Information necessary to service the system safely is included in the SRS and SB section of this Service Manual.

**WARNING:**

- To avoid rendering the SRS inoperative, which could increase the risk of personal injury or death in the event of a collision which would result in air bag inflation, all maintenance must be performed by an authorized NISSAN/INFINITI dealer.
- Improper maintenance, including incorrect removal and installation of the SRS can lead to personal injury caused by unintentional activation of the system. For removal of Spiral Cable and Air Bag Module, see the SRS section.
- Do not use electrical test equipment on any circuit related to the SRS unless instructed to in this Service Manual. SRS wiring harnesses can be identified by yellow and/or orange harnesses or harness connectors.
- When working near the Airbag Diagnosis Sensor Unit or other Airbag System sensors with the Ignition ON or engine running, DO NOT use air or electric power tools or strike near the sensor(s) with a hammer. Heavy vibration could activate the sensor(s) and deploy the air bag(s), possibly causing serious injury.
- When using air or electric power tools or hammers, always switch the Ignition OFF, disconnect the battery, and wait at least 3 minutes before performing any service.

#### Precaution Necessary for Steering Wheel Rotation After Battery Disconnect

INFOID:000000004407019

**NOTE:**

- This Procedure is applied only to models with Intelligent Key system and NATS (NISSAN ANTI-THEFT SYSTEM).
- Remove and install all control units after disconnecting both battery cables with the ignition knob in the "LOCK" position.
- Always use CONSULT-III to perform self-diagnosis as a part of each function inspection after finishing work. If DTC is detected, perform trouble diagnosis according to self-diagnostic results.

For models equipped with the Intelligent Key system and NATS, an electrically controlled steering lock mechanism is adopted on the key cylinder.

For this reason, if the battery is disconnected or if the battery is discharged, the steering wheel will lock and steering wheel rotation will become impossible.

If steering wheel rotation is required when battery power is interrupted, follow the procedure below before starting the repair operation.

#### OPERATION PROCEDURE

1. Connect both battery cables.

**NOTE:**

Supply power using jumper cables if battery is discharged.

2. Use the Intelligent Key or mechanical key to turn the ignition switch to the "ACC" position. At this time, the steering lock will be released.
3. Disconnect both battery cables. The steering lock will remain released and the steering wheel can be rotated.
4. Perform the necessary repair operation.
5. When the repair work is completed, return the ignition switch to the "LOCK" position before connecting the battery cables. (At this time, the steering lock mechanism will engage.)
6. Perform a self-diagnosis check of all control units using CONSULT-III.

# PRECAUTIONS

< SERVICE INFORMATION >

[QR25DE]

## Precaution for Liquid Gasket

INFOID:000000004407020

### REMOVAL OF LIQUID GASKET SEALING

- After removing nuts and bolts, separate the mating surface, using Tool and remove old liquid gasket sealing.

**Tool number : KV10111100 (J-37228)**

#### CAUTION:

**Be careful not to damage the mating surfaces.**

- Tap (1) Tool to insert it, and then slide (2) it by tapping on the side as shown.
- In areas where Tool is difficult to use, use plastic hammer to lightly tap the part, to remove it.

#### CAUTION:

**If for some unavoidable reason suitable tool such as screwdriver is used, be careful not to damage the mating surfaces.**

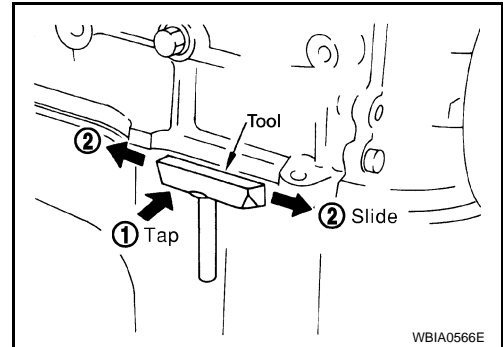

### LIQUID GASKET APPLICATION PROCEDURE

1. Remove old liquid gasket adhering to the liquid gasket application surface and the mating surface, Using scraper.
  - Remove liquid gasket completely from the groove of the liquid gasket application surface, bolts, and bolt holes.
2. Thoroughly clean the mating surfaces and remove adhering moisture, grease and foreign materials.

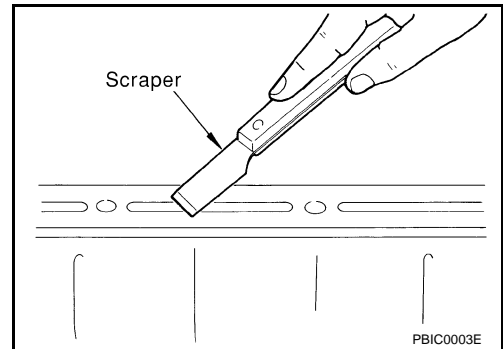

3. Attach liquid gasket tube to Tool.

**Tool number : WS39930000 ( — )**

**Use Genuine RTV Silicone Sealant or equivalent. Refer to [GI-42. "Recommended Chemical Product and Sealant"](#).**

4. Apply liquid gasket without breaks to the specified location with the specified dimensions.
  - If there is a groove for the liquid gasket application, apply liquid gasket to the groove.

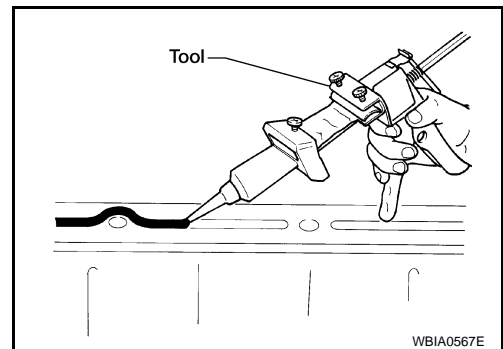

- As for the bolt holes, normally apply liquid gasket inside the holes. Occasionally, it should be applied outside the holes. Make sure to read the text of service manual.
- Within five minutes of liquid gasket application, install the mating component.
- If liquid gasket protrudes, wipe it off immediately.
- Do not retighten nuts or bolts after the installation.
- After 30 minutes or more have passed from the installation, fill engine oil and engine coolant.

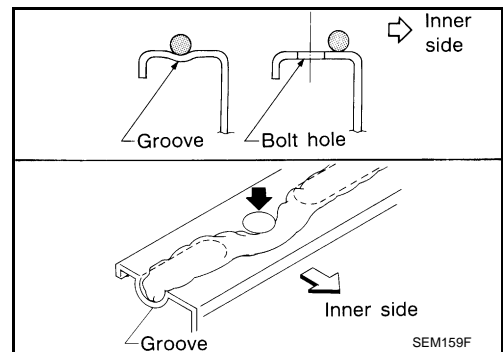

#### CAUTION:

**If there are specific instructions in this manual, observe them.**

# PREPARATION

< SERVICE INFORMATION >

[QR25DE]

## PREPARATION

### Special Service Tool

INFOID:000000004407021

The actual shape of the Kent-Moore tools may differ from those special service tools illustrated here.

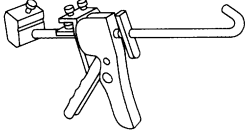
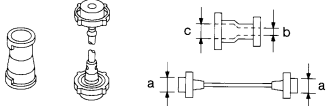
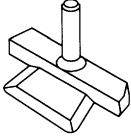
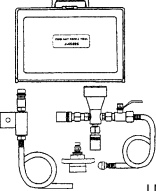
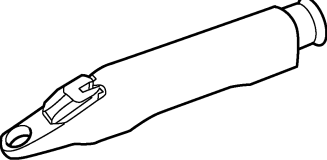
Tool number (Kent-Moore No.) Tool name	Description
WS39930000 ( — ) Tube presser  <p style="text-align: right;">S-NT052</p>	Pressing the tube of liquid gasket
EG17650301 (J-33984-A) Radiator cap tester adapter  <p style="text-align: right;">S-NT564</p>	Adapting radiator cap tester to radiator filler neck: <b>a: 28 (1.10) dia.</b> <b>b: 31.4 (1.236) dia.</b> <b>c: 41.3 (1.626) dia.</b> Unit: mm (in)
KV10111100 (J-37228) Seal cutter  <p style="text-align: right;">NT046</p>	Removing chain tensioner cover and water pump cover
KV991J0070 (J-45695) Coolant Refill Tool  <p style="text-align: right;">LMA053</p>	Refilling engine cooling system
— (J-23688) Engine coolant refractometer  <p style="text-align: right;">WBIA0539E</p>	Checking concentration of ethylene glycol in engine coolant

### Commercial Service Tool

INFOID:000000004407022

# PREPARATION

< SERVICE INFORMATION >

[QR25DE]

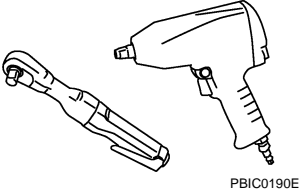
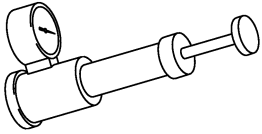
Tool name	Description
<p data-bbox="164 199 272 226">Power tool</p>  <p data-bbox="852 415 922 436">PBIC0190E</p>	<p data-bbox="1013 199 1263 226">Loosening bolts and nuts</p>
<p data-bbox="164 451 358 478">Radiator cap tester</p>  <p data-bbox="852 667 922 688">PBIC1982E</p>	<p data-bbox="1013 451 1360 478">Checking radiator and radiator cap</p>

A

CO

C

D

E

F

G

H

I

J

K

L

M

N

O

P

# OVERHEATING CAUSE ANALYSIS

< SERVICE INFORMATION >

[QR25DE]

## OVERHEATING CAUSE ANALYSIS

### Troubleshooting Chart

INFOID:000000004407023

		Symptom	Check items	
Cooling system parts malfunction	Poor heat transfer	Water pump malfunction	Worn or loose drive belt	—
		Thermostat stuck closed	Coolant circulation	
		Damaged fins	Dust contamination or rock clogging	
			Mechanical damage	
		Clogged radiator cooling tube	Excess foreign material (rust, dirt, sand, etc.)	
	Reduced air flow	Cooling fan does not operate	Engine cooling fans	—
		High resistance to fan rotation		
		Damaged fan blades		
		Damaged radiator shroud	—	—
		Improper coolant mixture ratio	—	—
		Poor coolant quality	—	Periodic maintenance
	Insufficient coolant	Coolant leaks	Cooling hose	Loose clamp
				Cracked hose
			Water pump	Poor sealing
			Radiator cap	Loose
Poor sealing				
Radiator			O-ring for damage, deterioration or improper fitting	
		Cracked radiator tank		
		Cracked radiator core		
	Reservoir tank	Cracked reservoir tank		
Overflowing reservoir tank	Exhaust gas leaks into cooling system	Cylinder head deterioration		
		Cylinder head gasket deterioration		



# OVERHEATING CAUSE ANALYSIS

< SERVICE INFORMATION >

[QR25DE]

	Symptom		Check items		
Except cooling system parts malfunction	—	Overload on engine	Abusive driving	High engine rpm under no load	A
				Driving in low gear for extended time	<b>CO</b>
				Driving at extremely high speed	
				Powertrain system malfunction	C
				Installed improper size wheels and tires	D
				Dragging brakes	
		Improper ignition timing	E		
	Blocked or restricted air flow	Blocked radiator grille	Installed car brassiere		E
		Blocked bumper	Mud contamination or paper clogging	—	
		Blocked radiator			F
Blocked condenser					
Installed large fog lamp					
			G		
			H		
			I		
			J		
			K		
			L		
			M		
			N		
			O		
			P		

# COOLING SYSTEM

[QR25DE]

< SERVICE INFORMATION >

## COOLING SYSTEM

### Cooling Circuit

INFOID:000000004407024

M/T Models

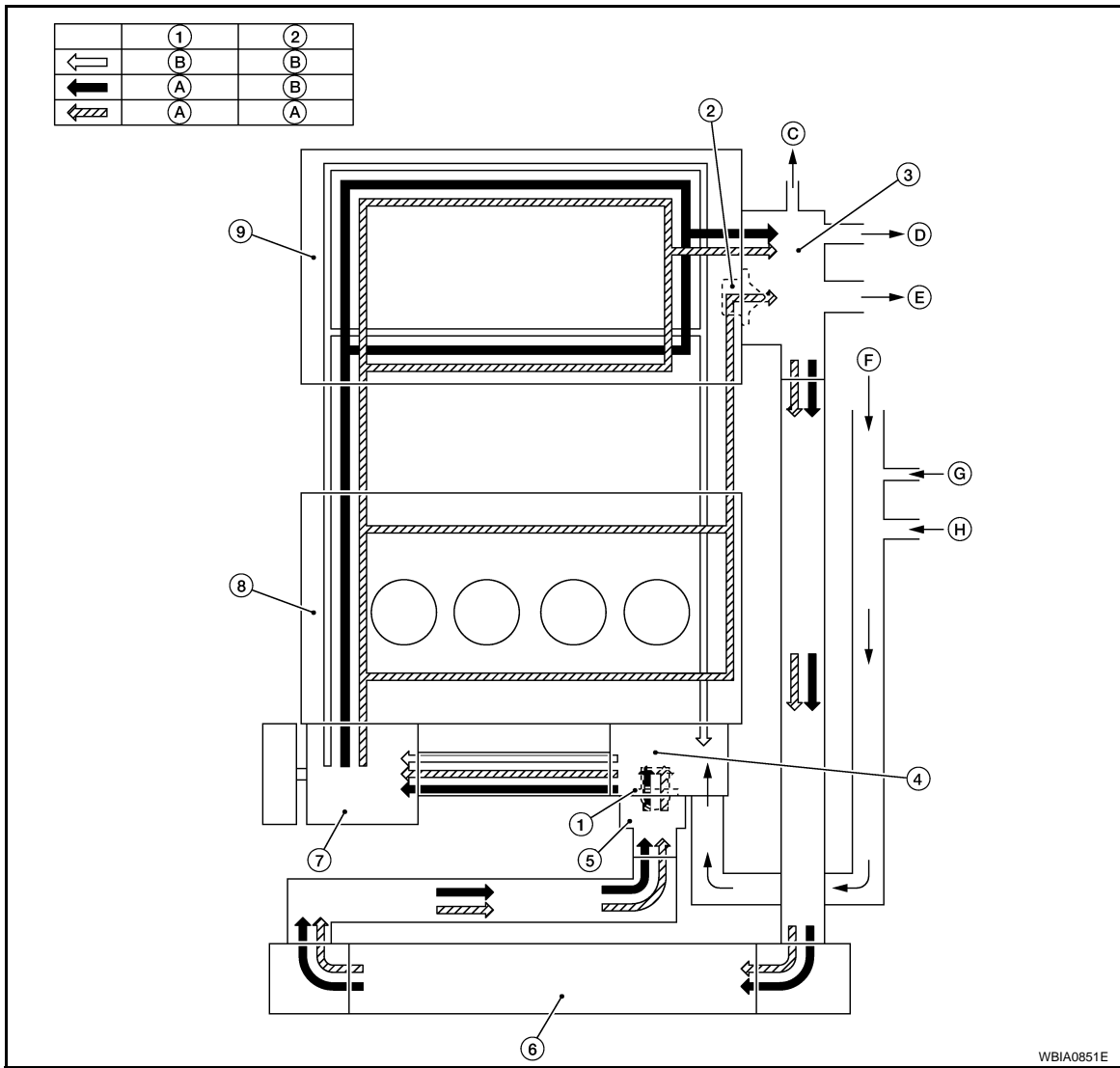

WBIA0851E

- |  |                        |   |
|--|------------------------|---|
| 1. Thermostat                          | 2. Water control valve | 3. Water control valve housing (Water outlet) |
| 4. Cylinder block (Thermostat housing) | 5. Water inlet         | 6. Radiator                                   |
| 7. Water pump                          | 8. Cylinder block      | 9. Cylinder head                              |
| A. Open                                | B. Closed              | C. To electric throttle control actuator      |
| D. To oil cooler                       | E. To heater           | E. From heater                                |
| G. From oil cooler                     | H. To heater           |   |

# COOLING SYSTEM

< SERVICE INFORMATION >

[QR25DE]

CVT Models

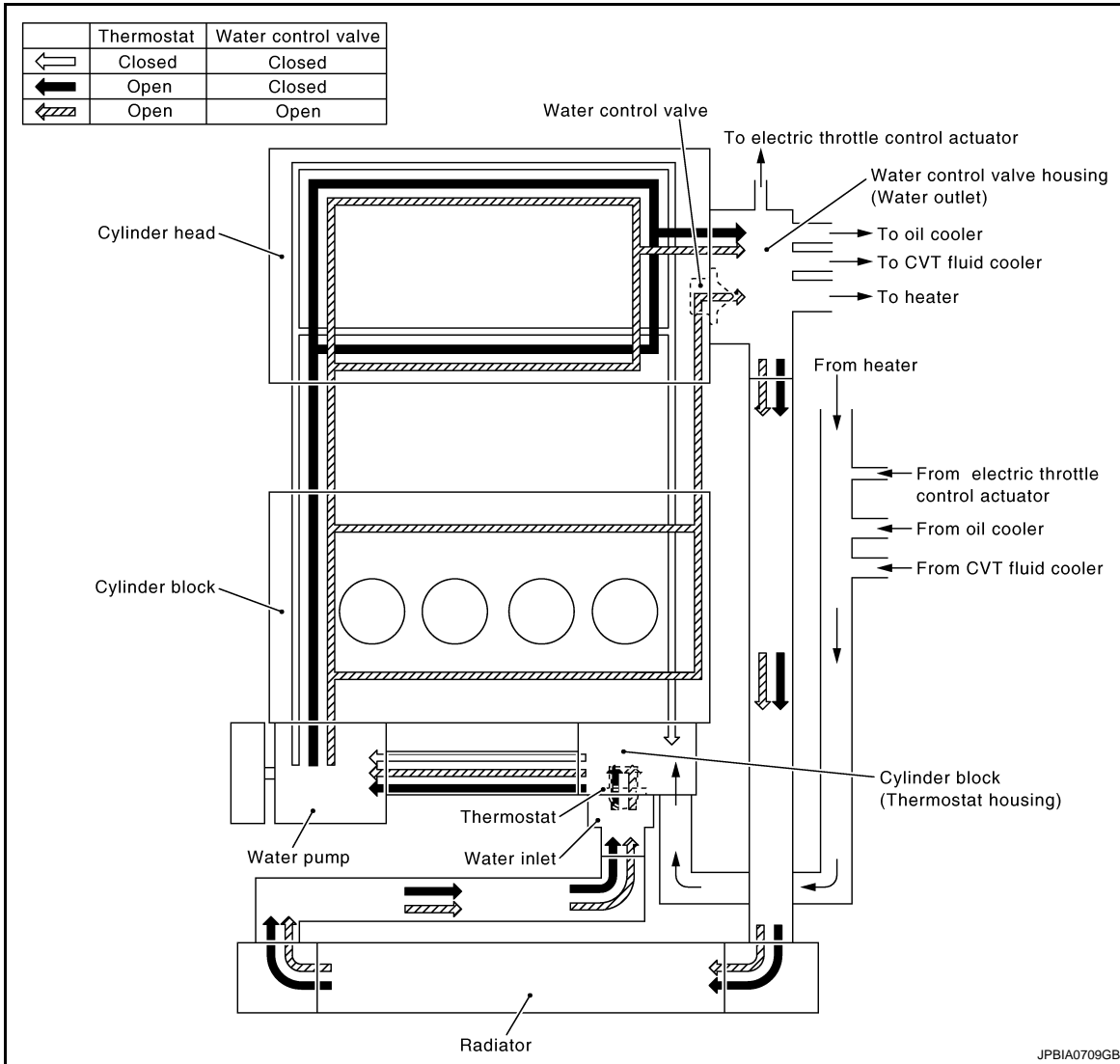

A

CO

C

D

E

F

G

H

I

J

K

L

M

N

O

P

# COOLING SYSTEM

< SERVICE INFORMATION >

[QR25DE]

## Schematic

INFOID:000000004407025

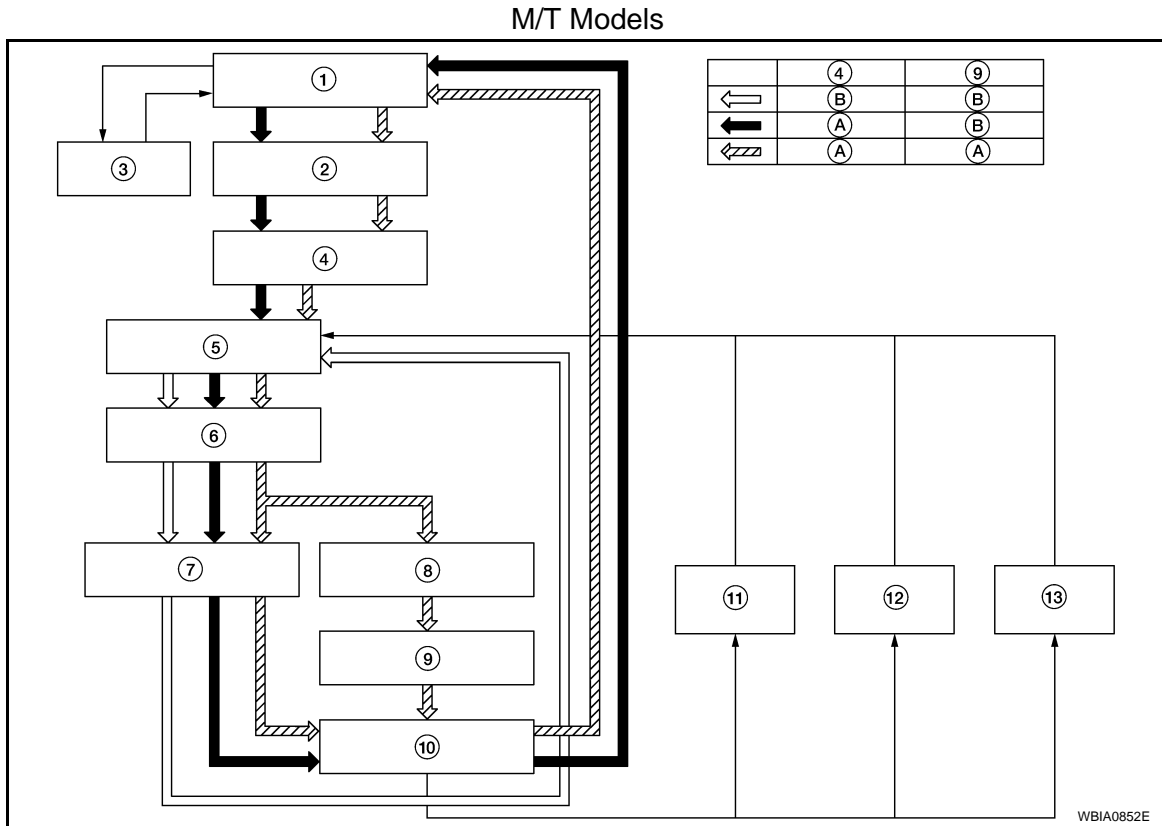

- |  |                       |                        |
|--|-----------------------|------------------------|
| 1. Radiator                            | 2. Water inlet        | 3. Reservoir tank      |
| 4. Thermostat                          | 5. Thermostat housing | 6. Water pump          |
| 7. Cylinder head                       | 8. Cylinder block     | 9. Water control valve |
| 10. Water control valve housing        | 11. Heater            | 12. Oil cooler         |
| 13. Electric throttle control actuator | A. Open               | B. Closed              |

# COOLING SYSTEM

< SERVICE INFORMATION >

[QR25DE]

CVT Models

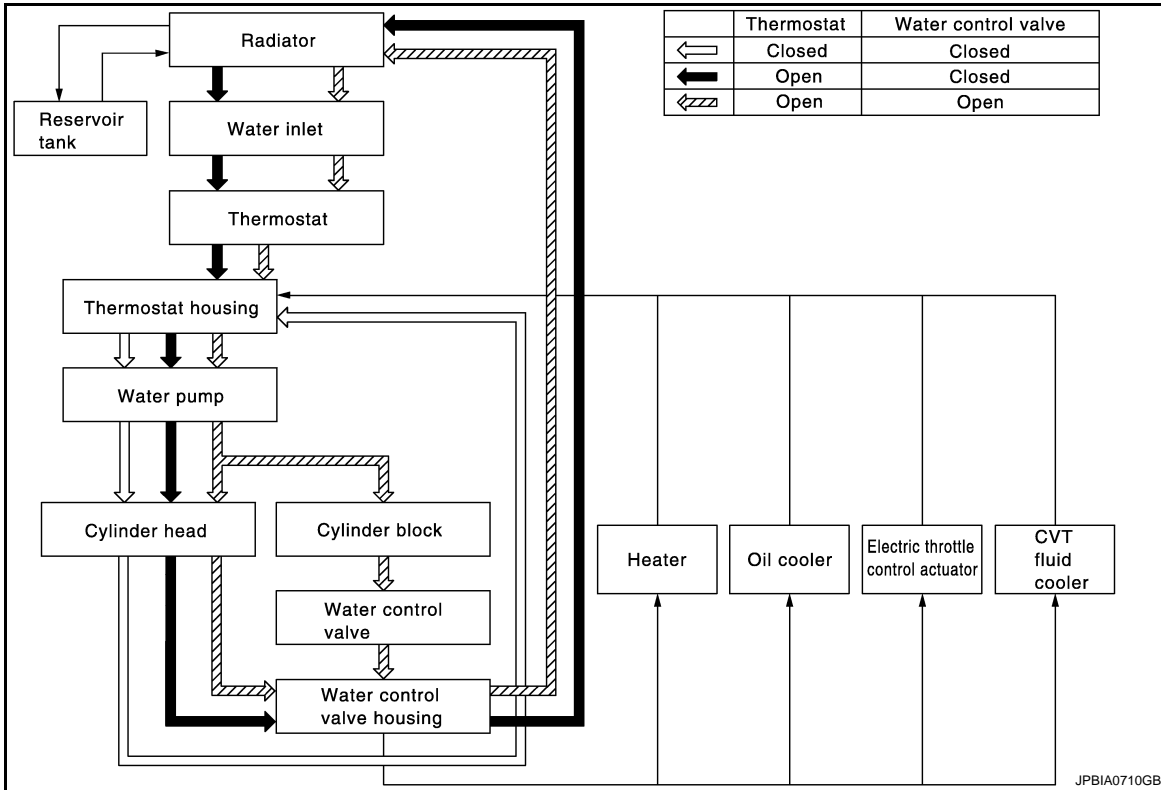

A

CO

C

D

E

F

G

H

I

J

K

L

M

N

O

P

## ENGINE COOLANT

## Inspection

INFOID:000000004407026

**WARNING:**

- Never remove the radiator cap when the engine is hot. Serious burns could occur from high pressure fluid escaping from the radiator.
- Wrap a thick cloth around the cap. Slowly push down and turn it a quarter turn to allow built-up pressure to escape. Carefully remove the cap by pushing down and turning it all the way.

## CHECKING COOLING SYSTEM HOSES

Check hoses for the following:

- Improper attachment
- Leaks
- Cracks
- Damage
- Loose connections
- Chafing
- Deterioration

## CHECKING RESERVOIR LEVEL

- Check if the reservoir tank engine coolant level is within MIN to MAX when the engine is cool.
- Adjust the engine coolant level as necessary.

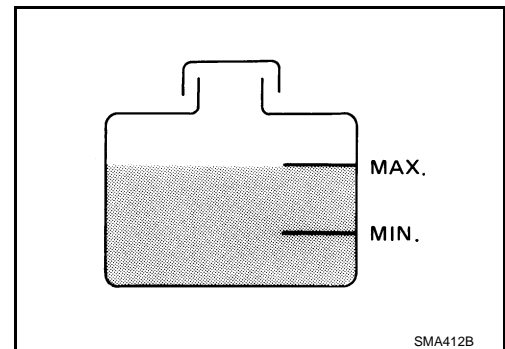

## CHECKING COOLING SYSTEM FOR LEAKS

To check for leakage, apply pressure to the cooling system using Tool.

**Tool number** : EG17650301 (J-33984-A)

**Testing pressure** : 157 kPa (1.6 kg/cm<sup>2</sup>, 23 psi)

**WARNING:**

Never remove the radiator cap when the engine is hot. Serious burns could occur from high pressure coolant escaping from the radiator.

**CAUTION:**

Higher pressure than specified may cause radiator damage.

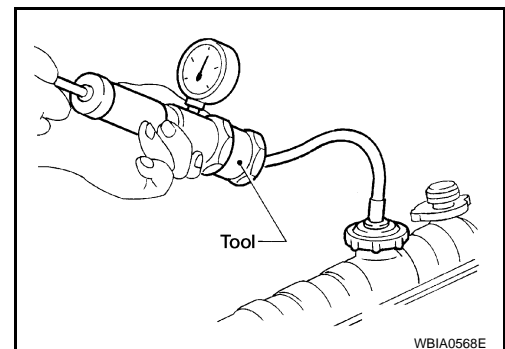

## CHECKING RADIATOR CAP

1. Inspect the radiator cap.
  - Replace the cap if the metal plunger cannot be seen around the edge of the black rubber gasket.
  - Replace the cap if deposits of waxy residue or other foreign material are on the black rubber gasket or the metal retainer.

**NOTE:**

Thoroughly wipe out the radiator filler neck to remove any waxy residue or foreign material.

# ENGINE COOLANT

[QR25DE]

## < SERVICE INFORMATION >

2. Pull the negative-pressure valve to open it and check that it closes completely when released.
  - Check that there is no dirt or damage on the valve seat of the radiator cap negative-pressure valve.
  - Check that there are no abnormalities in the opening and closing conditions of the negative-pressure valve.

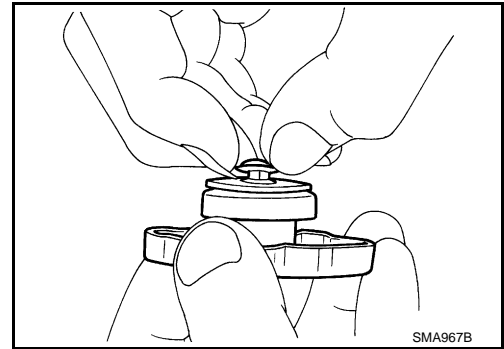

3. Check radiator cap relief pressure using Tool.

**Tool number : EG17650301 (J-33984-A)**

**Standard: 78 – 98 kPa (0.8 – 1.0 kg/cm<sup>2</sup>, 11 – 14 psi)**

**Limit: 59 kPa (0.6 kg/cm<sup>2</sup>, 9 psi)**

- When connecting the radiator cap to the tester, apply water or coolant to the cap seal surface.
- Replace the radiator cap if there is an abnormality in the negative-pressure valve, or if the open-valve pressure is outside of the standard values.

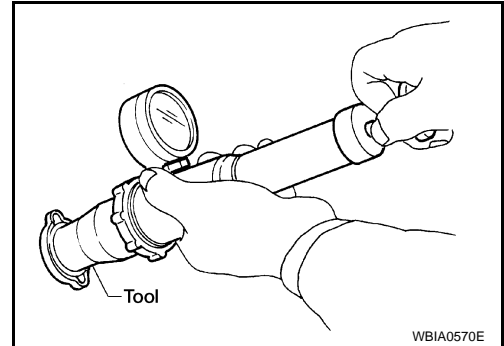

## CHECKING RADIATOR

Check radiator for mud or clogging. If necessary, clean radiator as follows.

- Be careful not to bend or damage the radiator fins.
  - When radiator is cleaned without removal, remove all surrounding parts such as cooling fan shroud and horns. Then tape the harness and electrical connectors to prevent water from entering.
1. Apply water by hose to the back side of the radiator core, with the hose pointed vertically downward.
  2. Apply water again to all radiator core surfaces once per minute.
  3. Stop washing if any stains no longer flow out from the radiator.
  4. Blow air into the back side of radiator core, with the air hose pointed vertically downward.
    - Use compressed air lower than 490 kPa (5 kg/cm<sup>2</sup>, 71 psi) and keep distance more than 30 cm (11.8 in).
  5. Blow air again into all the radiator core surfaces once per minute until no water sprays out.
  6. Check for leaks.

## Changing Engine Coolant

INFOID:000000004407027

### **WARNING:**

- **To avoid being scalded, do not change the engine coolant when the engine is hot.**
- **Wrap a thick cloth around radiator cap and carefully remove the cap. First, turn the cap a quarter of a turn to release built-up pressure. Then push down and turn the cap all the way to remove.**
- **Be careful no to allow engine coolant to contact drive belt.**

## DRAINING ENGINE COOLANT

1. Remove the engine undercover using power tool.

# ENGINE COOLANT

[QR25DE]

## < SERVICE INFORMATION >

2. Open the radiator drain plug (1) at the bottom of the radiator, and remove the radiator filler cap. This is the only step required when partially draining the cooling system (radiator only).

- ← Front

**CAUTION:**

- Perform this step when engine is cold.
- Do not spill engine coolant on drive belt.

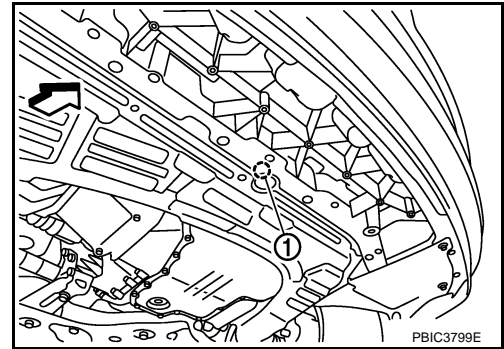

PBIC3799E

3. Follow this step for heater core removal/replacement only. Disconnect the upper heater hose at the engine side and apply moderate air pressure [103.46 kPa (15 psi, 1.055 kg/cm<sup>2</sup>) maximum air pressure] into the hose for 30 seconds to blow the excess coolant out of the heater core.
4. When draining all of the coolant in the system, remove the reservoir tank and drain the coolant, then clean the reservoir tank before installation.
5. When draining all of the coolant in the system for engine removal or repair, open the drain plug on the cylinder block.

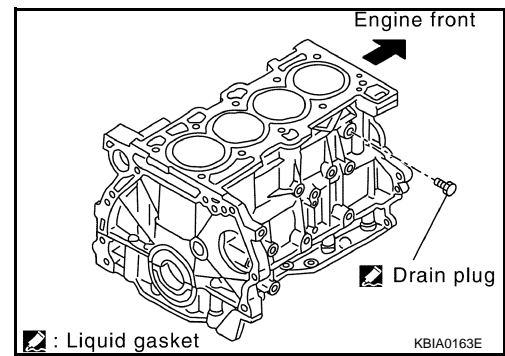

KBIA0163E

6. Check the drained engine coolant for contaminants such as rust, corrosion or discoloration. If the coolant is contaminated, flush the engine cooling system. Follow the "FLUSHING COOLING SYSTEM" procedure.

## REFILLING ENGINE COOLANT

1. Install the radiator drain plug. Install the reservoir tank and cylinder block drain plug, if removed for a total system drain or for engine removal or repair.
  - The radiator must be completely empty of coolant and water.
  - Apply sealant to the threads of the cylinder block drain plugs. Use Genuine High Performance Thread Sealant or equivalent. Refer to [GI-42, "Recommended Chemical Product and Sealant"](#).

**Radiator drain plug** : Refer to [CO-43, "Removal and Installation"](#).

**Cylinder block drain plug** : Refer to [EM-185](#).

2. If disconnected, reattach the upper radiator hose at the engine side.
3. Set the vehicle heater controls to the full HOT and heater ON position. Turn the vehicle ignition ON with the engine OFF as necessary to activate the heater mode.



# ENGINE COOLANT

[QR25DE]

## < SERVICE INFORMATION >

4. Install the Tool by installing the radiator cap adapter onto the radiator neck opening. Then attach the gauge body assembly with the refill tube and the venturi assembly to the radiator cap adapter.

**Tool number** : KV991J0070 (J-45695)

5. Insert the refill hose into the coolant mixture container that is placed at floor level. Make sure the ball valve is in the closed position.
  - Use **Genuine NISSAN Long Life Anti-freeze coolant or equivalent, mixed 50/50 with distilled water or demineralized water.**  
Refer to [MA-16. "Anti-freeze Coolant Mixture Ratio"](#).

**Engine coolant capacity (with reservoir tank)** : Refer to [MA-14](#).

6. Install an air hose to the venturi assembly, the air pressure must be within specification.

**Compressed air supply pressure** : 5.7 - 8.5 kPa (5.6 - 8.4 kg/cm<sup>2</sup>, 80 - 120 psi)

### CAUTION:

**The compressed air supply must be equipped with an air dryer.**

7. The vacuum gauge will begin to rise and there will be an audible hissing noise. During this process open the ball valve on the refill hose slightly. Coolant will be visible rising in the refill hose. Once the refill hose is full of coolant, close the ball valve. This will purge any air trapped in the refill hose.
8. Continue to draw the vacuum until the gauge reaches 28 inches of vacuum. The gauge may not reach 28 inches in high altitude locations, use the vacuum specifications below based on the altitude above sea level.

Altitude above sea level	Vacuum gauge reading
0 - 100 m (328 ft)	: 28 inches of vacuum
300 m (984 ft)	: 27 inches of vacuum
500 m (1,641 ft)	: 26 inches of vacuum
1,000 m (3,281 ft)	: 24 - 25 inches of vacuum

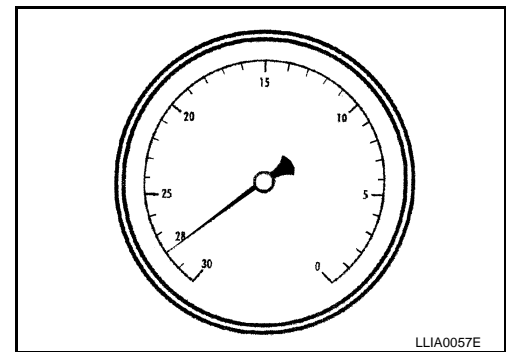
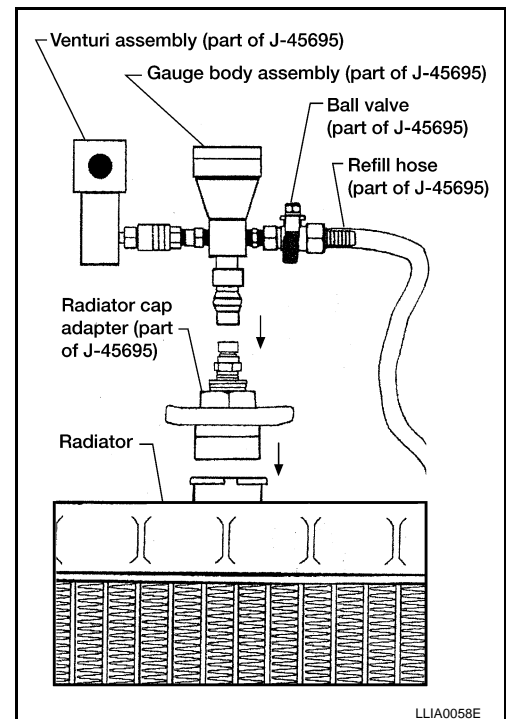

9. When the vacuum gauge has reached the specified amount, disconnect the air hose and wait 20 seconds to see if the system loses any vacuum. If the vacuum level drops, perform any necessary repairs to the system and repeat steps 6 - 8 to bring the vacuum to the specified amount. Recheck for any leaks.
10. Place the coolant container (with the refill hose inserted) at the same level as the top of the radiator. Then open the ball valve on the refill hose so the coolant will be drawn up to fill the cooling system. The cooling system is full when the vacuum gauge reads zero.

### CAUTION:

**Do not allow the coolant container to get too low when filling, to avoid air from being drawn into the cooling system.**

11. Remove the Tool from the radiator neck opening.
12. Fill the cooling system reservoir tank to the specified level and install the radiator cap. Run the engine to warm up the cooling system and top up the system as necessary.

## FLUSHING COOLING SYSTEM

1. Fill radiator and reservoir tank with water and reinstall radiator cap.
2. Run engine until it reaches normal operating temperature.
3. Rev the engine two or three times under no-load.

## ENGINE COOLANT

< SERVICE INFORMATION >

[QR25DE]

---

4. Stop the engine and wait until it cools down.
5. Drain water from the cooling system.
6. Repeat steps 1 through 5 until clear water begins to drain from the radiator.

# RADIATOR

< SERVICE INFORMATION >

[QR25DE]

## RADIATOR

### Component

INFOID:000000004777164

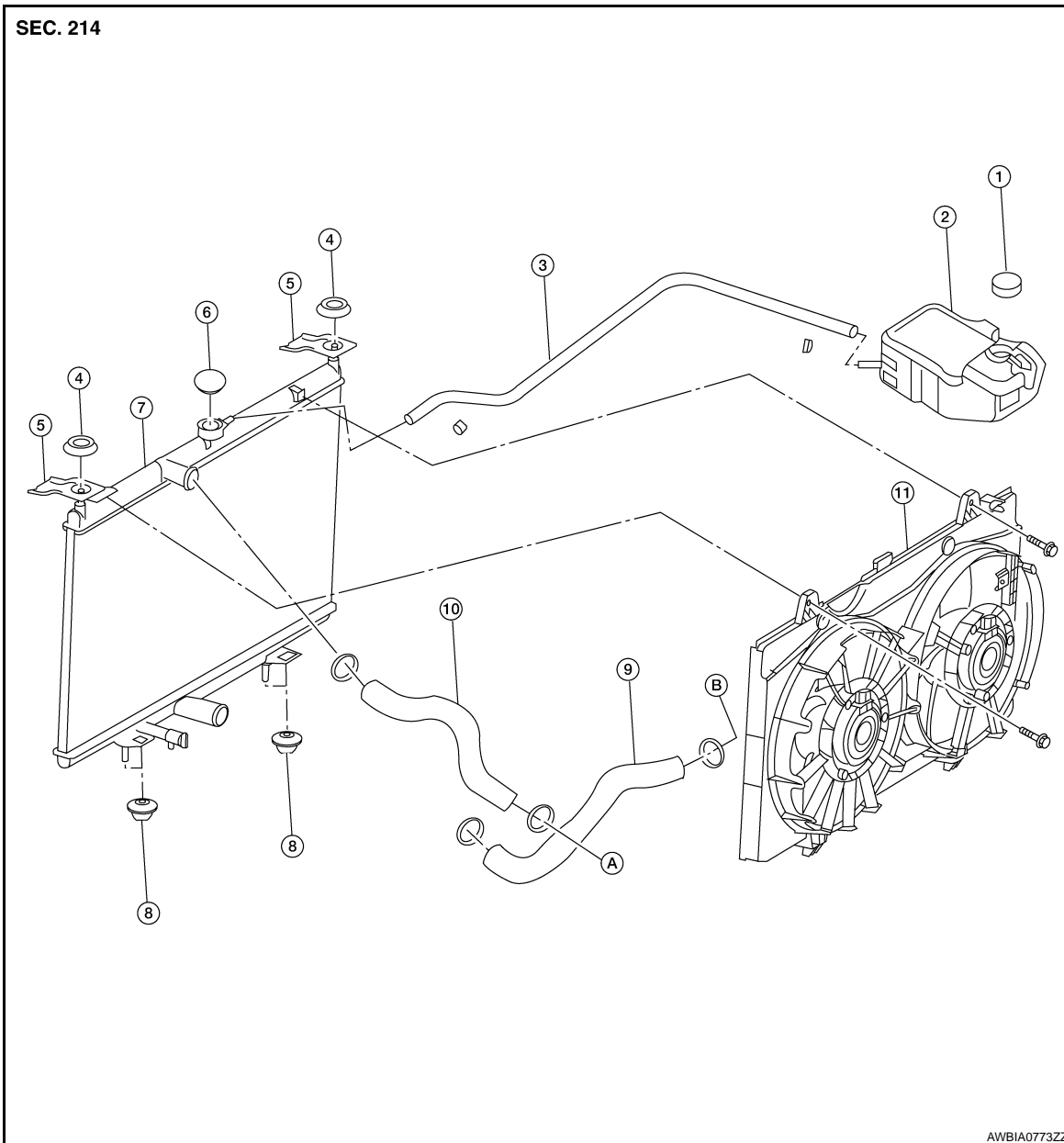

- |                            |                            |                          |
|----------------------------|----------------------------|--------------------------|
| 1. Reservoir tank cap      | 2. Reservoir tank          | 3. Reservoir tank hose   |
| 4. Mounting rubber (upper) | 5. Radiator upper mounts   | 6. Radiator cap          |
| 7. Radiator                | 8. Mounting rubber (lower) | 9. Radiator hose (lower) |
| 10. Radiator hose (upper)  | 11. Cooling fan assembly   | A. To water outlet       |
| B. To water inlet          |                            |                          |

### Removal and Installation

INFOID:000000004407028

#### **WARNING:**

**Do not remove the radiator cap when the engine is hot. Serious burns could occur from high pressure engine coolant escaping from the radiator. Wrap a thick cloth around the cap. Slowly turn it a quarter turn to release built-up pressure. Carefully remove the radiator cap by turning it all the way.**

#### REMOVAL

# RADIATOR

[QR25DE]

## < SERVICE INFORMATION >

1. Drain engine coolant from the radiator. Refer to [CO-39. "Changing Engine Coolant"](#).  
**CAUTION:**
  - Perform this step when engine is cold.
  - Do not spill engine coolant on drive belt
2. Remove front air duct. Refer to [EM-131. "Removal and Installation"](#).
3. Disconnect radiator upper and lower hoses.
4. Disconnect the reservoir tank hose.
5. Disconnect harness connectors from fan motors, and position harness aside.
6. Remove the cooling fan assembly to radiator bolts and remove cooling fan assembly.
7. Remove radiator upper mounts.
8. Move the radiator assembly to the rearward direction of vehicle, and then lift it upward to remove.  
**CAUTION:**  
**Do not damage or scratch A/C condenser and radiator core when removing.**

### INSPECTION AFTER REMOVAL

Inspect radiator for leaks as follows:

- Apply pressure using Tool.

**Specified pressure value** : 157 kPa (1.6 kg/cm<sup>2</sup>, 23 psi)

**Tool number** : EG17650301 (J-33984-A)

#### **WARNING:**

To prevent the risk of the hose coming undone while under pressure, securely fasten it down with a hose clamp.

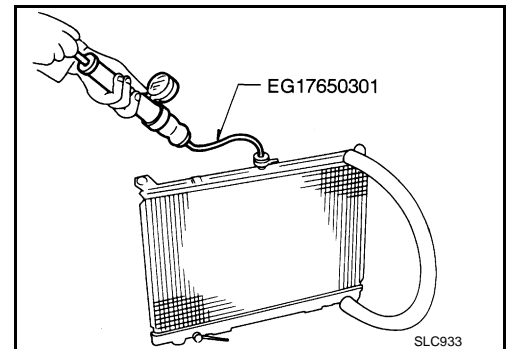

- Check for leakage.

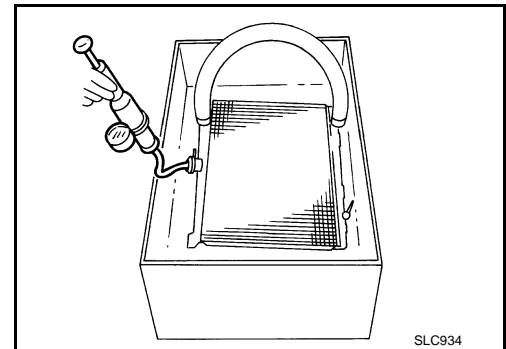

### INSTALLATION

Installation is in the reverse order of removal.

#### **CAUTION:**

**Do not damage or scratch A/C condenser and radiator core when installing.**

### INSPECTION AFTER INSTALLATION

- Check for leaks of engine coolant. Refer to [CO-38. "Inspection"](#).
- Start and warm up engine. Visually check if there is no leaks of engine coolant and CVT fluid if equipped. Refer to [CVT-15](#).

## COOLING FAN

### Component

INFOID:000000004777165

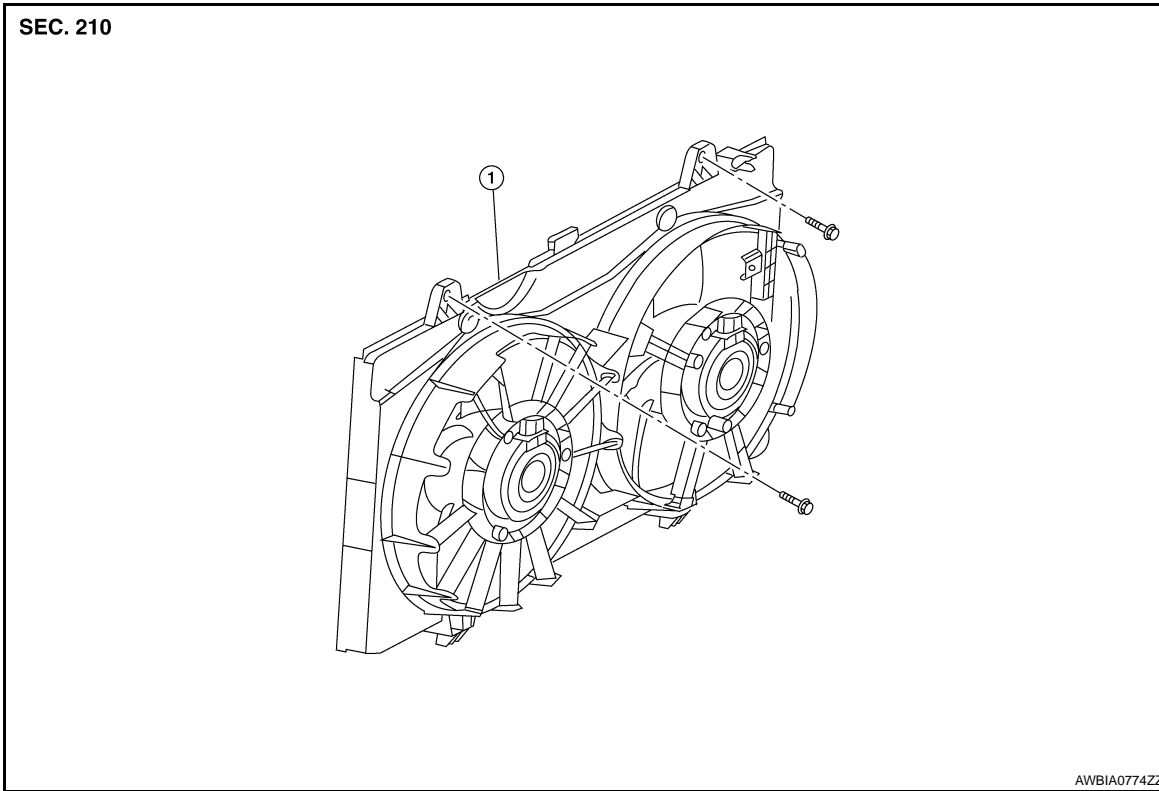

1. Cooling fan assembly

### Removal and Installation

INFOID:000000004407029

**WARNING:**

**Never remove the radiator cap when the engine is hot. Serious burns could occur from high pressure engine coolant escaping from the radiator.**

#### REMOVAL

1. Partially drain engine coolant from radiator. Refer to [CO-39, "Changing Engine Coolant"](#).

**CAUTION:**

- Perform this step when engine is cold.
- Do not spill engine coolant on drive belt.

2. Remove front air duct. Refer to [EM-131, "Removal and Installation"](#).
3. Disconnect radiator hose (upper) at radiator side. Refer to [CO-43, "Component"](#).
4. Disconnect harness connectors from fan motor, and position harness aside.
5. Remove cooling fan assembly.

**CAUTION:**

**Be careful not to damage or scratch the radiator core.**

#### INSTALLATION

Installation is in the reverse order of removal.

- Cooling fans are controlled by ECM. For details, refer to [EC-1508](#).

**CAUTION:**

**Be careful not to damage or scratch the radiator core.**

# COOLING FAN

< SERVICE INFORMATION >

[QR25DE]

## Disassembly and Assembly

INFOID:000000004407030

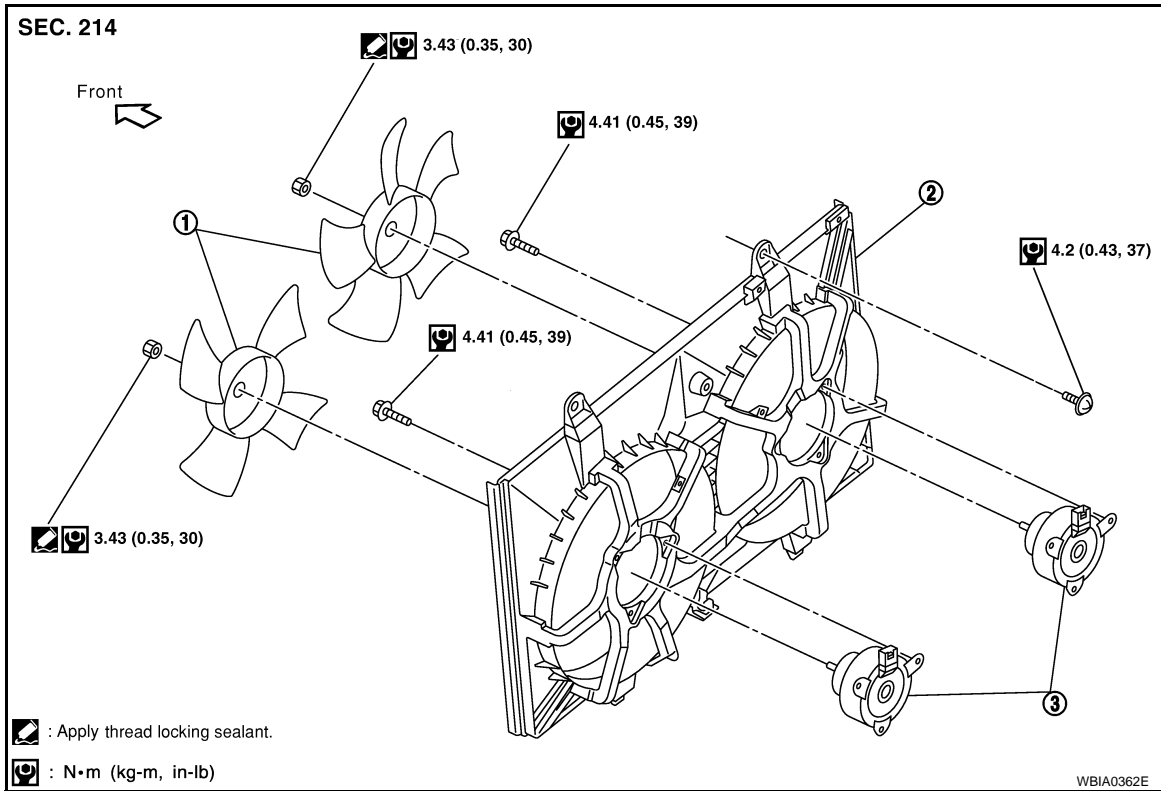

1. Fan blade

2. Fan shroud

3. Fan motor

### DISASSEMBLY

1. Remove fans from fan motors.
2. Remove fan motors from fan shroud.

### ASSEMBLY

Assembly is in the reverse order of disassembly.

## WATER PUMP

### Component

INFOID:000000004777166

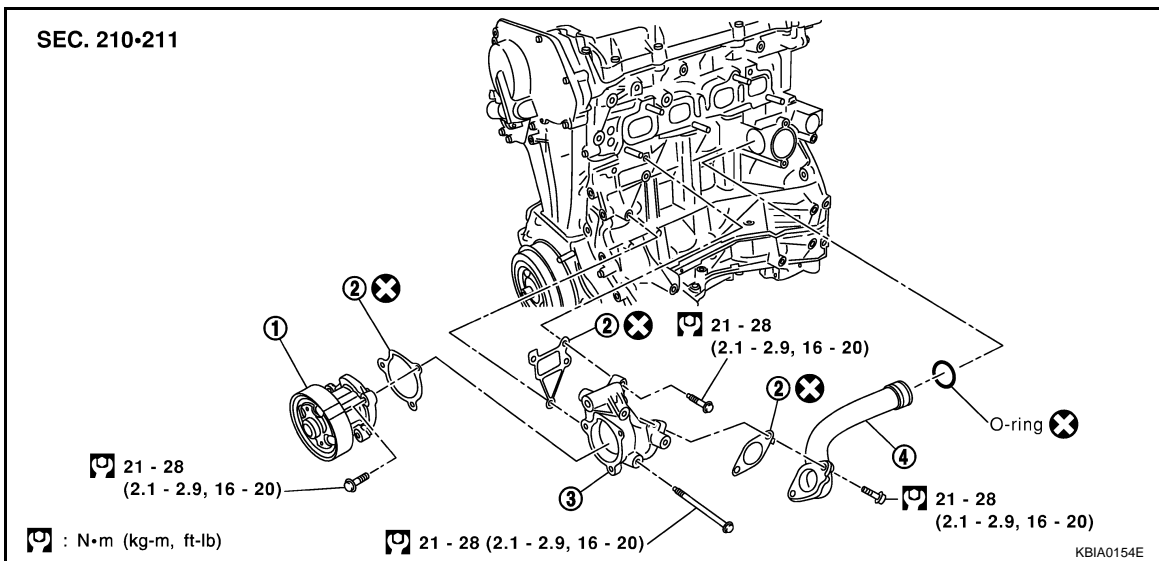

- |               |           |                       |
|---------------|-----------|-----------------------|
| 1. Water pump | 2. Gasket | 3. Water pump housing |
| 4. Water pipe |           |                       |

### Removal and Installation

INFOID:000000004407031

**WARNING:**

**Never remove the radiator cap when the engine is hot. Serious burns could occur from high pressure engine coolant escaping from the radiator.**

#### REMOVAL

1. Drain engine coolant from the radiator. Refer to [CO-39, "Changing Engine Coolant"](#).

**CAUTION:**

**Perform this step when the engine is cold.**

2. Remove engine undercover using power tools.
3. Remove drive belt. Refer to [EM-128, "Removal and Installation"](#).
4. Remove engine cover using power tools.
5. Remove engine coolant reservoir.
6. Remove IPDM E/R (set aside). Refer to [PG-27, "Removal and Installation of IPDM E/R"](#).
7. Remove RH wheel and tire assembly. Refer to [WT-8, "Rotation"](#).
8. Remove fender protector. Refer to [EI-22, "Removal and Installation"](#).
9. Remove engine ground strap.
10. Remove the water pump.

**NOTE:**

If necessary, the generator and exhaust manifold catalytic convertor assembly must be removed to remove the water pipe.

**CAUTION:**

- Handle the water pump vane so that it does not contact any other parts.
- Water pump cannot be disassembled and should be replaced as an assembly.

#### INSPECTION AFTER REMOVAL

## WATER PUMP

[QR25DE]

### < SERVICE INFORMATION >

- Visually check that there is no significant dirt or rusting on the water pump body and vane.
- Make sure that there is no looseness in the vane shaft, and that it turns smoothly when rotated by hand.
- Replace the water pump, if necessary.

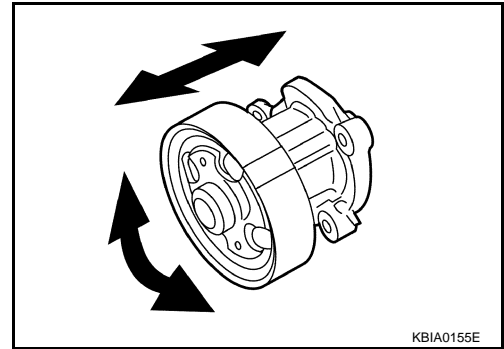

### INSTALLATION

- Installation is in the reverse order of removal.
- When inserting water pipe end to cylinder block, apply a neutral detergent to O-ring. Then insert it immediately.

### INSPECTION AFTER INSTALLATION

- Check for leaks of engine coolant. Refer to [CO-38, "Inspection"](#).
- Start and warm up the engine. Visually check for leaks of engine coolant.



# THERMOSTAT AND THERMOSTAT HOUSING

< SERVICE INFORMATION >

[QR25DE]

## THERMOSTAT AND THERMOSTAT HOUSING

Component

INFOID:000000004777167

M/T Models

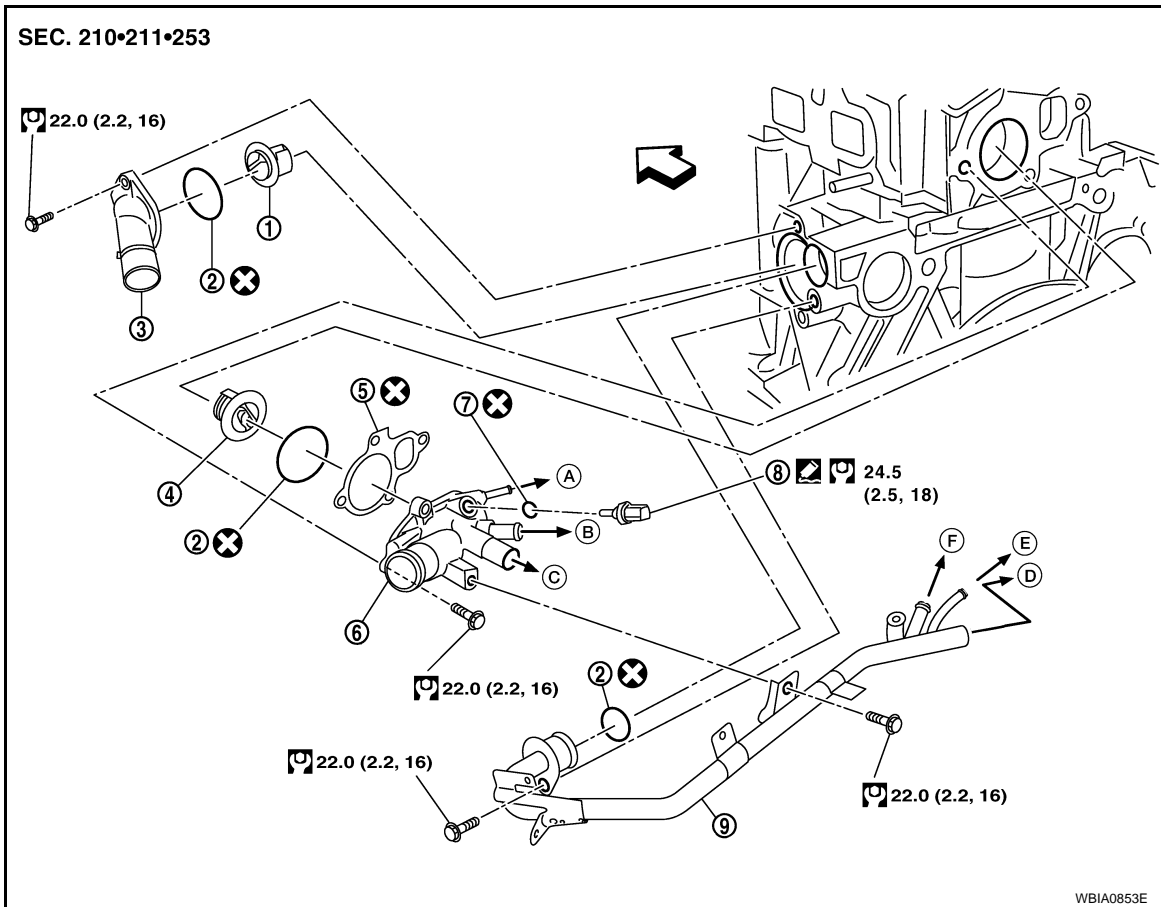

- |  |  |                          |
|--|--|--------------------------|
| 1. Thermostat                            | 2. O-ring                                | 3. Engine coolant inlet  |
| 4. Water control valve                   | 5. Gasket                                | 6. Engine coolant outlet |
| 7. Copper washer                         | 8. Engine coolant temperature sensor     | 9. Heater pipe           |
| A. To electric throttle control actuator | B. To oil cooler                         | C. To heater core        |
| D. To heater core                        | E. To electric throttle control actuator | F. To oil cooler         |

↶ Engine front

A  
CO  
C  
D  
E  
F  
G  
H  
I  
J  
K  
L  
M  
N  
O  
P

# THERMOSTAT AND THERMOSTAT HOUSING

< SERVICE INFORMATION >

[QR25DE]

CVT Models

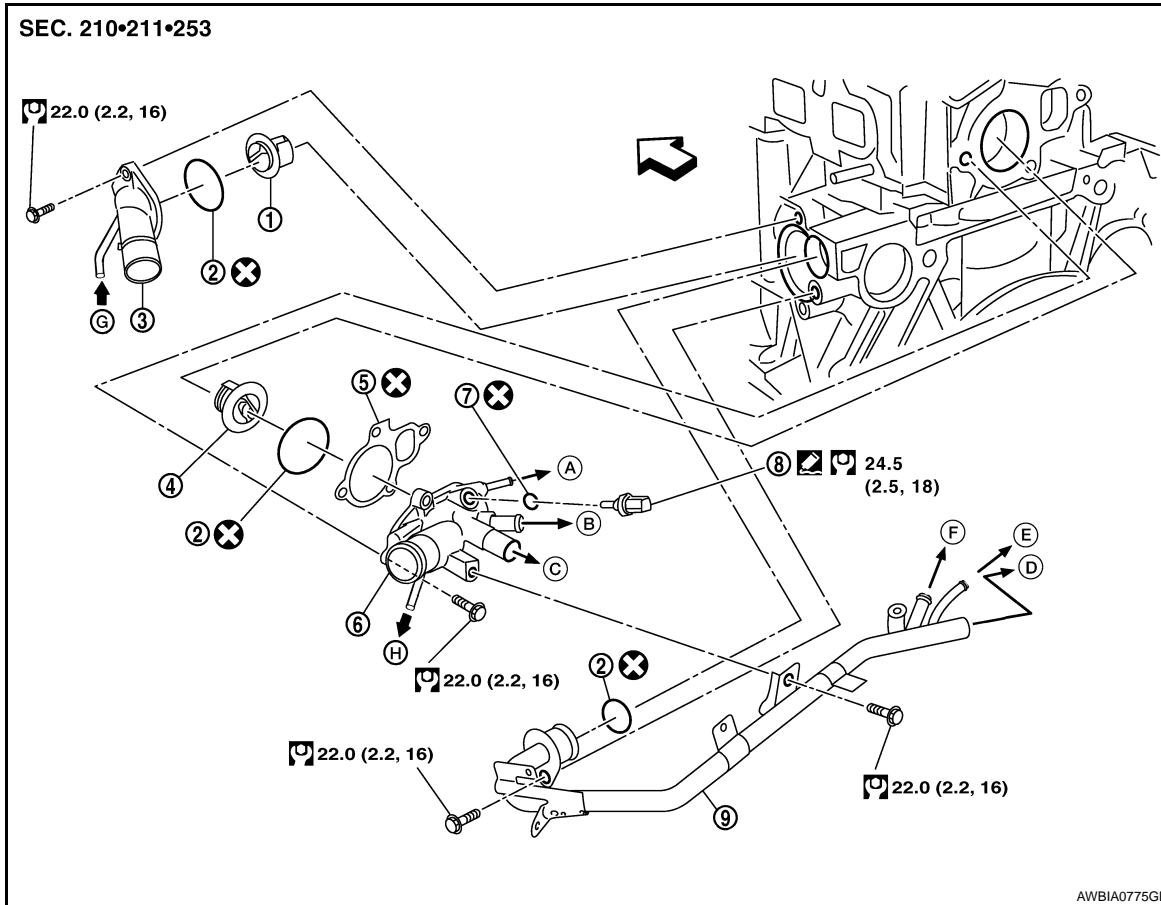

- |  |  |                          |
|--|--|--------------------------|
| 1. Thermostat                            | 2. O-ring                                | 3. Engine coolant inlet  |
| 4. Water control valve                   | 5. Gasket                                | 6. Engine coolant outlet |
| 7. Copper washer                         | 8. Engine coolant temperature sensor     | 9. Heater pipe           |
| A. To electric throttle control actuator | B. To oil cooler                         | C. To heater core        |
| D. To heater core                        | E. To electric throttle control actuator | F. To oil cooler         |
| G. From CVT oil cooler                   | H. To CVT oil cooler                     | ⇐ Engine front           |

## Removal and Installation

INFOID:000000004407032

### **WARNING:**

**Never remove the radiator cap when the engine is hot. Serious burns could occur from high pressure engine coolant escaping from the radiator.**

### REMOVAL

### **CAUTION:**

**Perform when the engine is cold.**

1. Remove engine undercover.
2. Drain engine coolant from the radiator. Refer to [CO-39, "Changing Engine Coolant"](#).
3. Remove front air duct. Refer to [EM-131, "Removal and Installation"](#).
4. Remove radiator hose (lower) from the engine coolant inlet side.
5. Remove engine coolant inlet and thermostat.

### INSPECTION AFTER REMOVAL

# THERMOSTAT AND THERMOSTAT HOUSING

[QR25DE]

## < SERVICE INFORMATION >

- Place a thread so that it is caught in the valves of the thermostat. Immerse fully in a container filled with water. Heat while stirring.
- The valve opening temperature is the temperature at which the valve opens and the thermostat falls from the thread.
- Continue heating. Check the full-open valve lift amount.

### NOTE:

- The full-open valve lift amount standard temperature for the thermostat is the reference value.
- After checking the full-open valve lift amount, lower the water temperature and check the valve closing temperature.

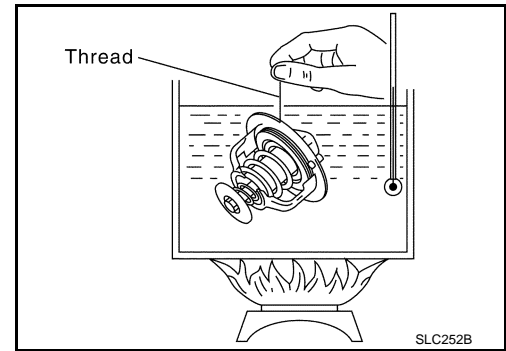

A

CO

C

D

E

F

G

H

I

J

K

L

M

N

O

P

Items	Thermostat
Valve opening temperature	80.5 – 83.5°C (177 – 182°F)
Full-open valve lift amount	More than 8 mm / 95°C (0.315 in / 203°F)
Valve closing temperature	77°C (171°F)

- If out of the specification, replace thermostat.

## INSTALLATION

Installation is in the reverse order of removal.

- Install the engine coolant temperature sensor.

**Use Genuine RTV Silicone Sealant or equivalent. Refer to [GI-42. "Recommended Chemical Product and Sealant"](#).**

- Install the thermostat with the whole circumference of the flange part fitting securely inside the rubber ring.
- Install the thermostat with the jiggle valve facing upwards. The position deviation may be within the range of  $\pm 10^\circ$ .
- If necessary, to install the heater pipe, first apply a mild detergent to the O-ring and then quickly insert the pipe into the housing.

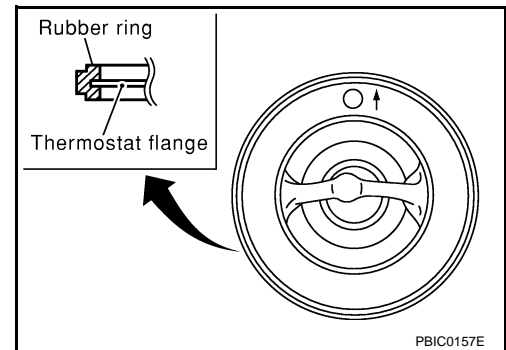

## INSPECTION AFTER INSTALLATION

- Check for leaks of engine coolant. Refer to [CO-38. "Inspection"](#).
- Start and warm up the engine. Visually check for engine coolant leaks.

# WATER CONTROL VALVE

< SERVICE INFORMATION >

[QR25DE]

## WATER CONTROL VALVE

Component

INFOID:000000004777168

M/T Models

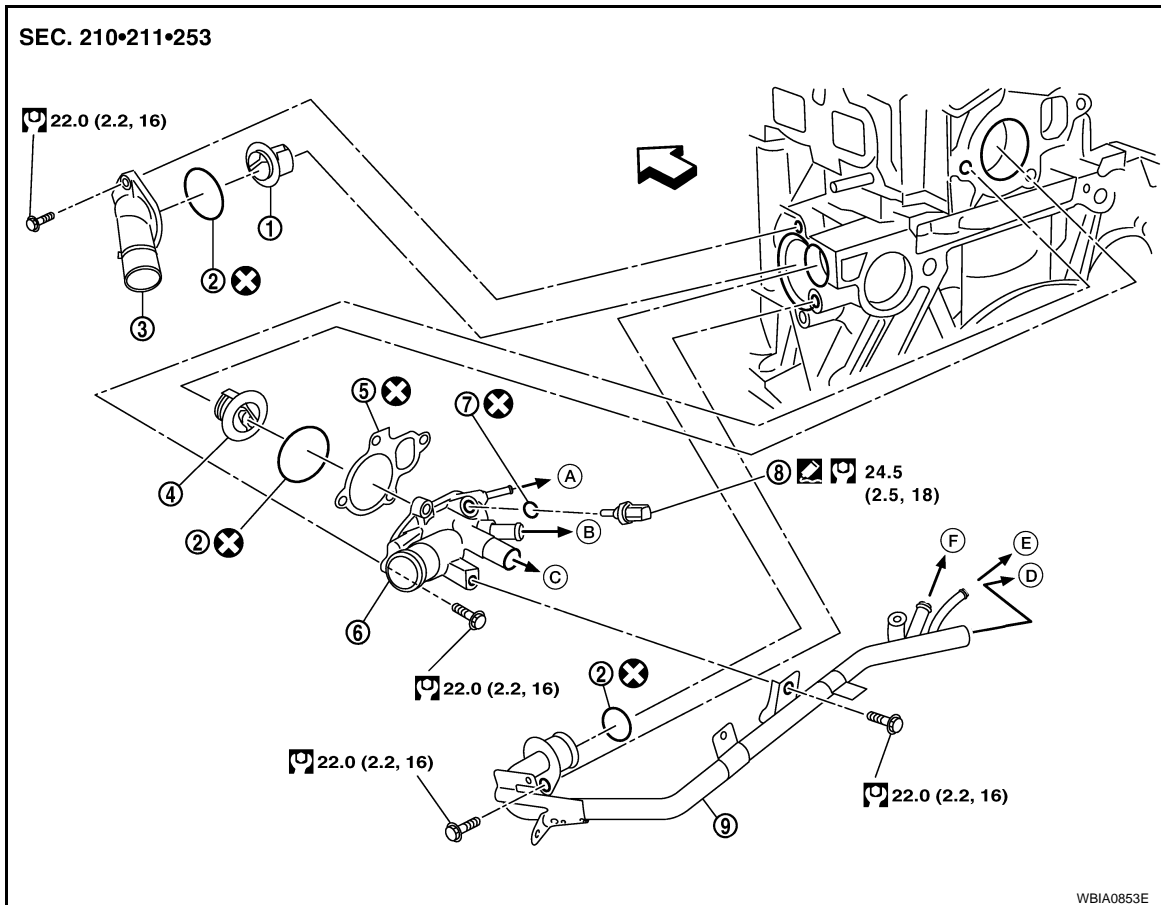

- |  |  |                          |
|--|--|--------------------------|
| 1. Thermostat                            | 2. O-ring                                | 3. Engine coolant inlet  |
| 4. Water control valve                   | 5. Gasket                                | 6. Engine coolant outlet |
| 7. Copper washer                         | 8. Engine coolant temperature sensor     | 9. Heater pipe           |
| A. To electric throttle control actuator | B. To oil cooler                         | C. To heater core        |
| D. To heater core                        | E. To electric throttle control actuator | F. To oil cooler         |
- ⇐ Engine front

# WATER CONTROL VALVE

< SERVICE INFORMATION >

[QR25DE]

CVT Models

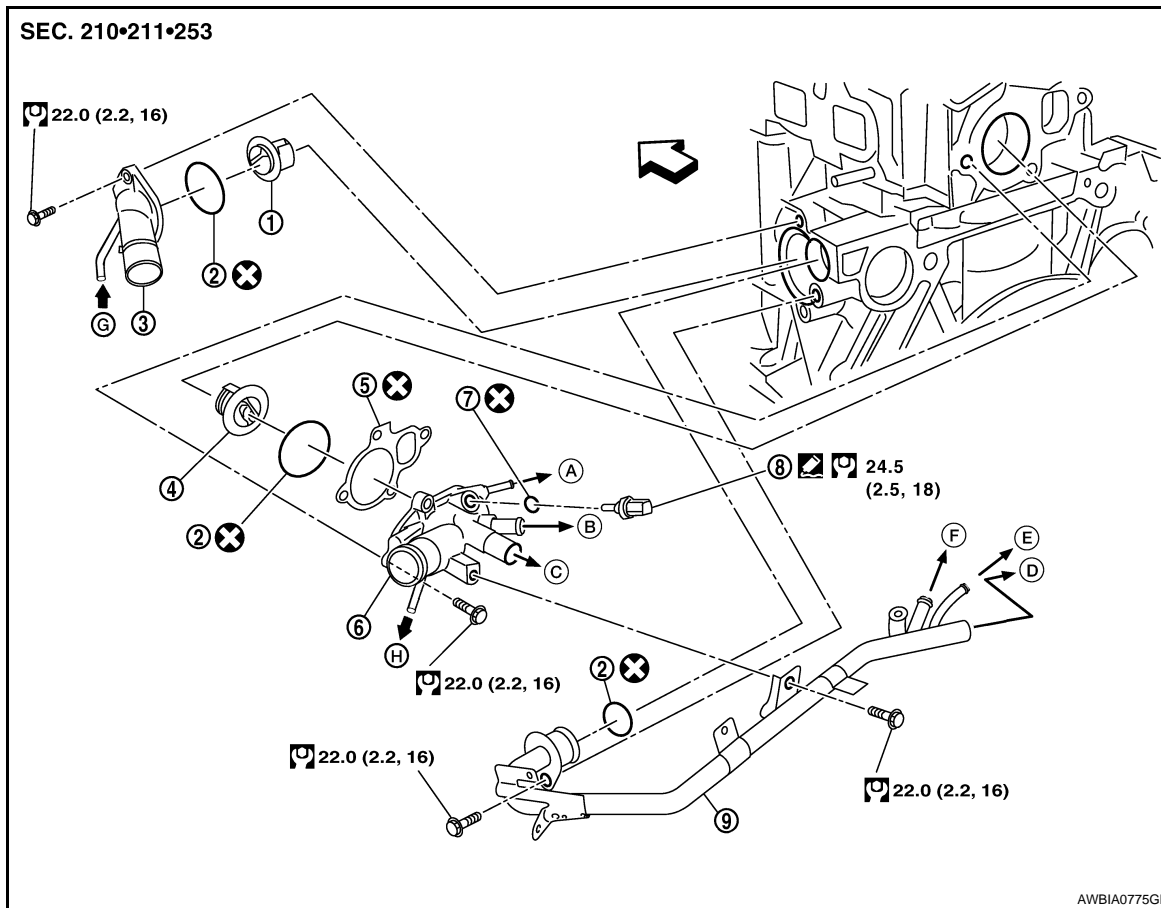

- |  |  |                          |
|--|--|--------------------------|
| 1. Thermostat                            | 2. O-ring                                | 3. Engine coolant inlet  |
| 4. Water control valve                   | 5. Gasket                                | 6. Engine coolant outlet |
| 7. Copper washer                         | 8. Engine coolant temperature sensor     | 9. Heater pipe           |
| A. To electric throttle control actuator | B. To oil cooler                         | C. To heater core        |
| D. To heater core                        | E. To electric throttle control actuator | F. To oil cooler         |
| G. From CVT oil cooler                   | H. To CVT oil cooler                     | ⇐ Engine Front           |

## Removal and Installation

INFOID:000000004407033

### **WARNING:**

Never remove the radiator cap when the engine is hot. Serious burns could occur from high pressure engine coolant escaping from the radiator.

### REMOVAL

#### **CAUTION:**

Perform when the engine is cold.

1. Drain engine coolant from the radiator. Refer to [CO-39, "Changing Engine Coolant"](#).
2. Remove the air cleaner and air duct assembly. Refer to [EM-131, "Removal and Installation"](#).
3. Remove battery tray with brackets. Refer to [SC-7, "Removal and Installation QR25DE"](#).
4. Remove the radiator hose (upper), heater pipe, electric throttle control actuator inlet hose, CVT fluid cooler hoses if equipped, heater hose and oil cooler hoses.
5. Remove the engine coolant outlet.
6. Remove the water control valve.
7. Remove engine coolant temperature sensor, if necessary.

#### **CAUTION:**

- Handle carefully to avoid any shock to engine coolant temperature sensor.
- Replace the gaskets and rubber rings with a new ones.

# WATER CONTROL VALVE

[QR25DE]

## < SERVICE INFORMATION >

### INSPECTION AFTER REMOVAL

- Place a thread so that it is caught in the valve of the water control valve. Immerse fully in a container filled with water. Heat while stirring.
- The valve opening temperature is the temperature at which the water control valve opens and the falls from the thread.
- Continue heating. Check the full-open valve lift amount.

**NOTE:**

The full-open valve lift amount standard temperature for the water control valve is the reference value.

- After checking the full-open valve lift amount, lower the water temperature and check the valve closing temperature.

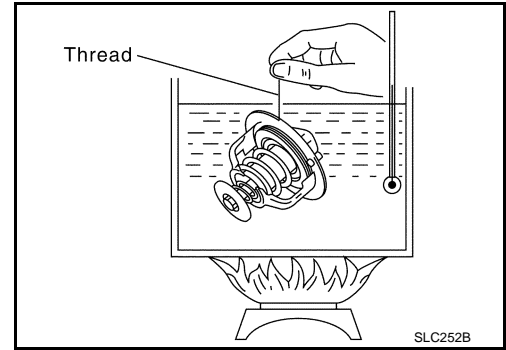

Items	Water control valve
Valve opening temperature	93.5° - 96.5°C (200° - 206°F)
Full-open valve lift amount	More than 8 mm / 108°C (0.315 in / 226° F)
Valve closing temperature	90°C (194° F)

- If out of the specification, replace water control valve.

### INSTALLATION

Installation is in the reverse order of removal.

- Install the engine coolant temperature sensor.  
**Use Genuine RTV Silicone Sealant or equivalent. Refer to [GI-42, "Recommended Chemical Product and Sealant"](#).**
- Install the water control valve with the whole circumference of the flange part fitting securely inside the rubber ring.
- Install the water control valve with the up-mark facing up and the frame center part facing upwards. The position deviation may be within the range of  $\pm 10^\circ$ .

### INSPECTION AFTER INSTALLATION

- Check for leaks of engine coolant. Refer to [CO-38, "Inspection"](#).
- Start and warm up the engine. Visually check if there is no leaks of engine coolant.

# SERVICE DATA AND SPECIFICATIONS (SDS)

< SERVICE INFORMATION >

[QR25DE]

## SERVICE DATA AND SPECIFICATIONS (SDS)

### Capacity

INFOID:000000004407034

Unit: ℓ (US qt, Imp qt)

Application	M/T models	CVT models
Engine coolant capacity (With reservoir tank at MAX level)	6.9 (7 1/4, 6 1/8)	7.1 (7 1/2, 6 1/4)

### Thermostat

INFOID:000000004407035

Valve opening temperature	80.5 - 83.5°C (177 - 182°F)
Full-open valve lift amount	More than 8 mm / 95°C (0.315 in / 203°F)
Valve closing temperature	77°C (171°F)

### Water Control Valve

INFOID:000000004407036

Valve opening temperature	93.5 - 96.5°C (200 - 206°F)
Full-open valve lift amount	More than 8 mm / 108°C (0.315 in / 226°F)
Valve closing temperature	90°C (194°F)

### Radiator

INFOID:000000004407037

Unit: kPa (kg / cm<sup>2</sup> , psi)

Cap relief pressure	Standard	78 - 98 (0.8 - 1.0, 11 - 14)
	Limit	59 (0.6, 9)
Leakage test pressure		157 (1.6, 23)