

SECTION **BR**
BRAKE SYSTEM

A
B
C
D
E

CONTENTS

SERVICE INFORMATION	2	VACUUM LINES	22	BR
PRECAUTIONS	2	Component	22	
Precaution for Supplemental Restraint System (SRS) "AIR BAG" and "SEAT BELT PRE-TENSIONER"	2	Removal and Installation	22	
Precaution for Brake System	2	Inspection	22	
PREPARATION	3	FRONT DISC BRAKE	24	
Special Service Tool	3	On Board Inspection	24	
Commercial Service Tool	3	Component	24	
NOISE, VIBRATION AND HARSHNESS (NVH) TROUBLESHOOTING	4	Removal and Installation of Brake Pad	25	
NVH Troubleshooting Chart	4	Removal and Installation of Brake Caliper Assembly	27	
BRAKE PEDAL	5	Disassembly and Assembly of Brake Caliper Assembly	29	
Inspection and Adjustment	5	Brake Burnishing	32	
Removal and Installation	6	REAR DISC BRAKE	33	
BRAKE FLUID	8	On Board Inspection	33	
On Board Inspection	8	Component	33	
Drain and Refill	8	Removal and Installation of Brake Pad	34	
Bleeding Brake System	9	Removal and Installation of Caliper Assembly	35	
BRAKE TUBE AND HOSE	10	Disassembly and Assembly of Caliper Assembly	37	
Hydraulic Circuit	10	Brake Burnishing	40	
Front Brake Tube and Hose	12	REAR DRUM BRAKE	41	
Rear Brake Tube and Hose	13	Component	41	
Inspection After Installation	15	Removal and Installation of Drum Brake Assembly	41	
DUAL PROPORTIONING VALVE	16	Removal and Installation of Wheel Cylinder	44	
Removal and Installation	16	Disassembly and Assembly of Wheel Cylinder	44	
Inspection	16	SERVICE DATA AND SPECIFICATIONS (SDS)	46	
BRAKE MASTER CYLINDER	18	General Specification	46	
On-Board Inspection	18	Brake Pedal	46	
Removal and Installation	18	Check Valve	47	
BRAKE BOOSTER	20	Brake Booster	47	
On Board Inspection	20	Dual Proportioning Valve	47	
Removal and Installation	20	Front Disc Brake	47	
		Rear Disc Brake	48	
		Rear Drum Brake	48	

G
H
I
J
K
L
M
N
O
P

PRECAUTIONS

< SERVICE INFORMATION >

SERVICE INFORMATION

PRECAUTIONS

Precaution for Supplemental Restraint System (SRS) "AIR BAG" and "SEAT BELT PRE-TENSIONER"

INFOID:000000004780844

The Supplemental Restraint System such as "AIR BAG" and "SEAT BELT PRE-TENSIONER", used along with a front seat belt, helps to reduce the risk or severity of injury to the driver and front passenger for certain types of collision. This system includes seat belt switch inputs and dual stage front air bag modules. The SRS system uses the seat belt switches to determine the front air bag deployment, and may only deploy one front air bag, depending on the severity of a collision and whether the front occupants are belted or unbelted. Information necessary to service the system safely is included in the SRS and SB section of this Service Manual.

WARNING:

- To avoid rendering the SRS inoperative, which could increase the risk of personal injury or death in the event of a collision which would result in air bag inflation, all maintenance must be performed by an authorized NISSAN/INFINITI dealer.
- Improper maintenance, including incorrect removal and installation of the SRS can lead to personal injury caused by unintentional activation of the system. For removal of Spiral Cable and Air Bag Module, see the SRS section.
- Do not use electrical test equipment on any circuit related to the SRS unless instructed to in this Service Manual. SRS wiring harnesses can be identified by yellow and/or orange harnesses or harness connectors.
- When working near the Airbag Diagnosis Sensor Unit or other Airbag System sensors with the Ignition ON or engine running, DO NOT use air or electric power tools or strike near the sensor(s) with a hammer. Heavy vibration could activate the sensor(s) and deploy the air bag(s), possibly causing serious injury.
- When using air or electric power tools or hammers, always switch the Ignition OFF, disconnect the battery, and wait at least 3 minutes before performing any service.

Precaution for Brake System

INFOID:000000004406681

- Refill using recommended brake fluid. Refer to [MA-14](#).
- Never reuse drained brake fluid.
- Be careful not to splash brake fluid on painted surface of body. If brake fluid is splashed on painted surfaces of body immediately wipe it off with cloth and then wash it away with water.
- To clean or wash all parts of master cylinder, disc brake caliper and wheel cylinder, use new brake fluid.
- Never use mineral oils such as gasoline or kerosene. They will ruin rubber parts of the hydraulic system.
- Use a flare nut wrench when removing a brake tube and use a flare nut torque wrench when installing a brake tube.
- When installing brake tubes and hoses, be sure to check torque.
- Before working, turn ignition switch OFF and disconnect connectors of ABS actuator and electric unit (control unit) or the battery cable from the negative terminal.
- Burnish the new braking surfaces after refinishing or replacing drums or rotors, after replacing pads or linings, or if a soft pedal occurs at very low mileage. Refer to [BR-32](#), "Brake Burnishing".

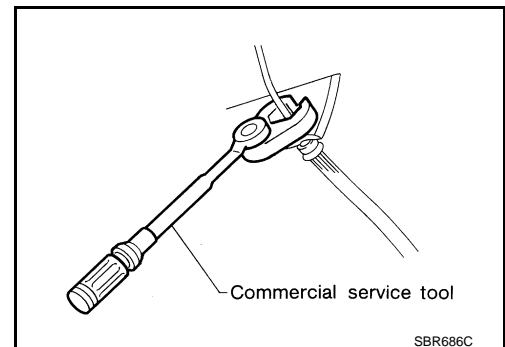

PREPARATION

< SERVICE INFORMATION >

PREPARATION

Special Service Tool

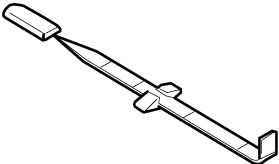
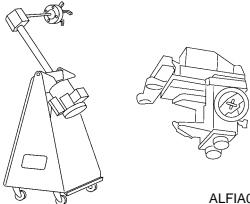

INFOID:000000004406682

The actual shapes of Kent-Moore tools may differ from those of special service tools illustrated here.

Tool number (Kent-Moore No.) Tool name	Description
<p>— (J-46532) Brake and clutch pedal height measurement tool</p>  <p style="text-align: right;">LFIA0227E</p>	Measuring brake pedal height
<p>38-PFM90.5 (—) Pro-Cut PFM 90 On-Car Brake Lathe</p>  <p style="text-align: right;">ALFIA0092ZZ</p>	Turning rotors

Commercial Service Tool

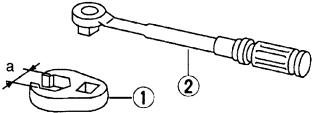
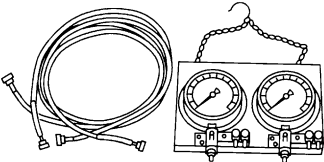
INFOID:000000004406683

Tool name	Description
<p>1 Flare nut crowfoot 2 Torque wrench</p>  <p style="text-align: right;">S-NT360</p>	Removing and installing each brake piping a: 10 mm (0.39 in)/12mm (0.47 in)
<p>Brake fluid pressure gauge</p>  <p style="text-align: right;">NT151</p>	Measuring brake fluid pressure
<p>Power tool</p>  <p style="text-align: right;">PIIB1407E</p>	Removing nuts, bolts, and screws

NOISE, VIBRATION AND HARSHNESS (NVH) TROUBLESHOOTING

< SERVICE INFORMATION >

NOISE, VIBRATION AND HARSHNESS (NVH) TROUBLESHOOTING

NVH Troubleshooting Chart

INFOID:000000004406684

Use the chart below to help you find the cause of the symptom. If necessary, repair or replace these parts.

Symptom		Possible cause and SUSPECTED PARTS													Reference page				
		Pads/Lining damaged	Pads/Lining - uneven wear	Shims damaged	Rotor imbalance	Rotor damage	Rotor runout	Rotor deformation	Rotor deflection	Rotor rust	Rotor thickness variation	Drum out of round	WHEEL HUB	SUSPENSION	TIRES	ROAD WHEEL	DRIVE SHAFT	STEERING	
Noise	Noise	x	x	x															BR-24, BR-41 BR-24, BR-41 — BR-29 BR-29 BR-29 BR-29 BR-29 — BR-29 BR-41 FAX-5, "NVH Troubleshooting Chart", RAX-5, "NVH Troubleshooting Chart" FSU-6, "NVH Troubleshooting Chart", RSU-4, "NVH Troubleshooting Chart" WT-4, "NVH Troubleshooting Chart" WT-4, "NVH Troubleshooting Chart" FAX-5, "NVH Troubleshooting Chart" PS-6, "NVH Troubleshooting Chart"
	Shake				x							x	x	x	x	x	x	x	
	Shimmy, Shudder				x	x	x	x	x	x	x	x		x	x	x			x

x: Applicable

BRAKE PEDAL

< SERVICE INFORMATION >

BRAKE PEDAL

Inspection and Adjustment

INFOID:000000004406685

INSPECTION

1. Inspect the brake pedal height (H) and brake pedal full stroke (S) from the floor using Tool at a 90° angle to the floor.

Tool number : — (J-46532)

2. Adjust the brake pedal height to specification.

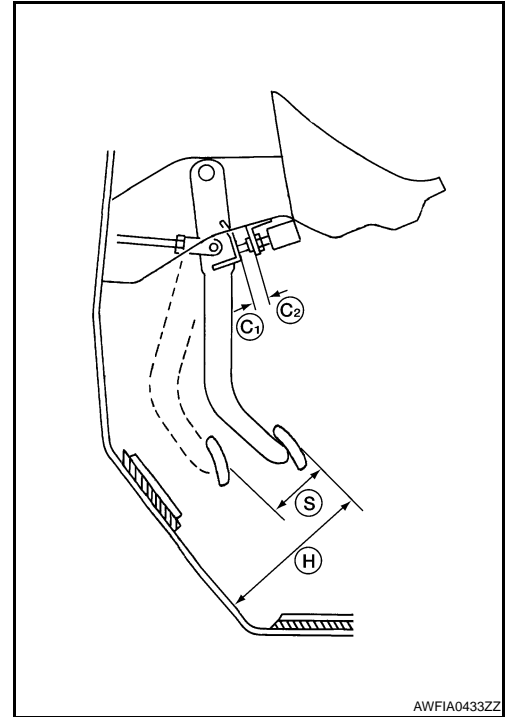

Brake Pedal Specifications

Brake pedal height (H) (from dash lower panel top surface)	CVT	Refer to BR-46, "Brake Pedal" .
	M/T	Refer to BR-46, "Brake Pedal" .
Brake pedal full stroke (S) [under a force of 490 N (50 kg-f, 110 lb-f) with engine running]	CVT	Refer to BR-46, "Brake Pedal" .
	M/T	Refer to BR-46, "Brake Pedal" .
Clearance between stopper bracket and threaded end of the stop lamp switch and ASCD cancel switch (C1 and C2)		Refer to BR-46, "Brake Pedal" .

ADJUSTMENT

BRAKE PEDAL

< SERVICE INFORMATION >

1. Loosen stop lamp switch and ASCD switch (if equipped) by rotating it counterclockwise by 45°.
2. Loosen lock nut on input rod, then rotate input rod to set pedal to the specified height, and tighten lock nut.

CAUTION:

Make sure that the threaded end of input rod stays inside clevis.

Lock nut : Refer to [BR-6, "Removal and Installation"](#).

3. With the pedal pulled and held by hand, press stop lamp switch or ASCD switch (if equipped) until its threaded end contacts brake pedal lever.
4. With the threaded end of stop lamp switch or ASCD switch (if equipped) contacting brake pedal lever, rotate the switch clockwise by 45° to secure.

CAUTION:

Make sure that the clearance (C1,C2) is within the standard.

5. Start engine to check brake pedal full stroke.

CAUTION:

Make sure that stop lamps go off when brake pedal is released.

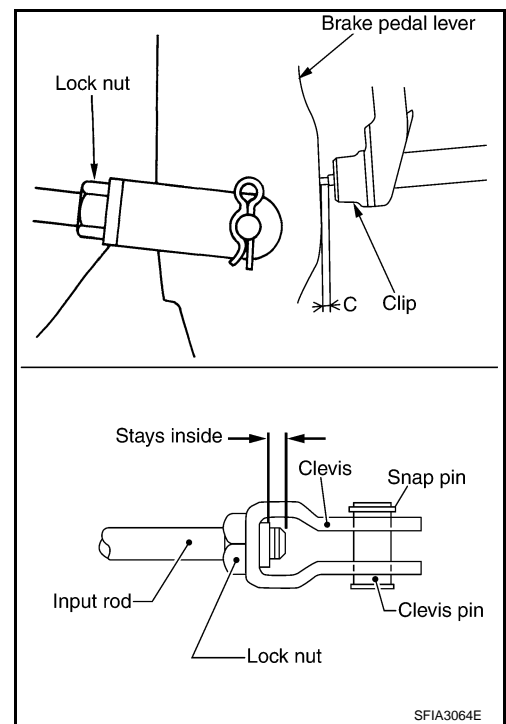

Removal and Installation

INFOID:000000004406686

COMPONENTS

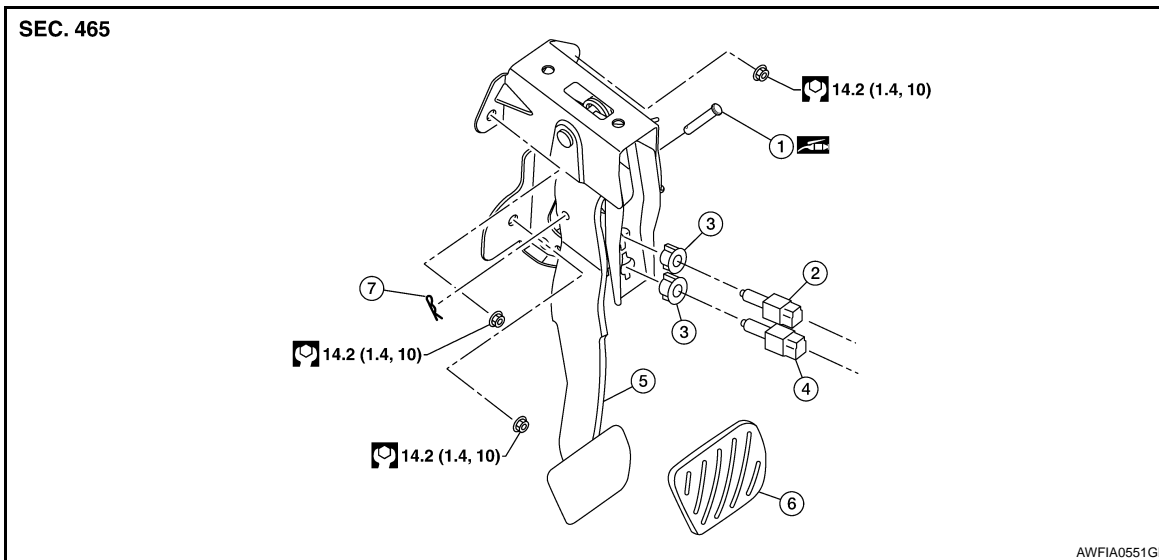

- | | | |
|---------------------|-------------------------|--------------------|
| 1. Clevis pin | 2. ASCD switch | 3. Clip |
| 4. Stop lamp switch | 5. Brake pedal assembly | 6. Brake pedal pad |
| 7. Snap pin | | |

NOTE:

The clevis pin must be installed from the right side as shown above.

REMOVAL

1. Disconnect accelerator pedal position sensor harness connector.
2. Remove stop lamp switch and ASCD switch (if equipped) from brake pedal assembly.

BRAKE PEDAL

< SERVICE INFORMATION >

3. Remove snap pin and clevis pin from clevis of brake booster.

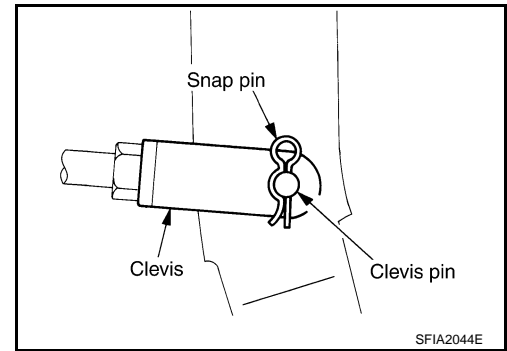

4. Remove nuts from brake pedal bracket, and remove brake pedal assembly.
5. Remove accelerator pedal from brake pedal assembly.

INSPECTION AFTER REMOVAL

- Check brake pedal for bend, damage, and cracks on the welded parts.
- Replace brake pedal assembly if any non-standard condition is detected.
- Check clevis pin and plastic stopper for damage and deformation.
Replace clevis pin as necessary.

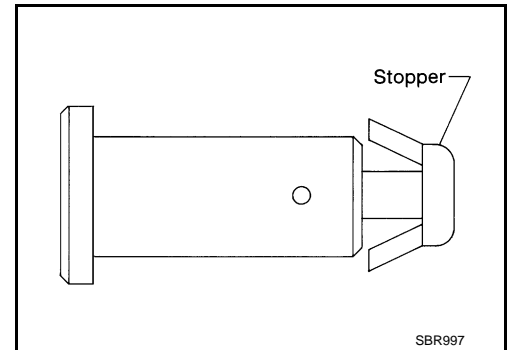

INSTALLATION

Installation is in the reverse order of the removal.

- After installing brake pedal assembly, adjust brake pedal. Refer to [BR-5. "Inspection and Adjustment"](#).
- After installing accelerator pedal, check accelerator pedal for proper operation.

NOTE:

The clevis pin must be installed from the right side.

BRAKE FLUID

< SERVICE INFORMATION >

BRAKE FLUID

On Board Inspection

INFOID:000000004406687

CHECKING BRAKE FLUID LEVEL

- Make sure the fluid level in the reservoir tank is between MAX and MIN lines (A) as shown.

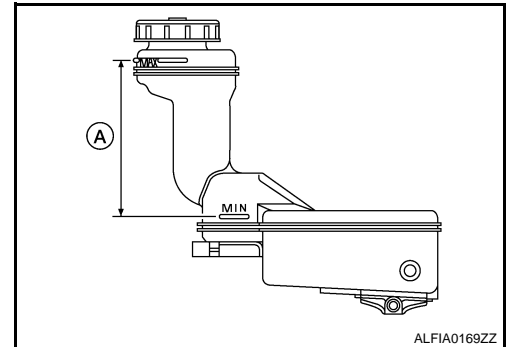

- Visually check around the reservoir tank for fluid leakage.
- If fluid level is excessively low, check brake system for fluid leakage.

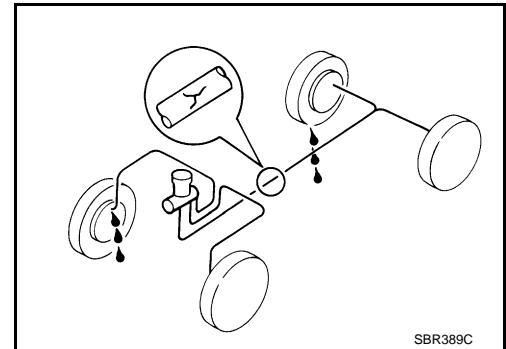

- Release parking brake lever and see if brake warning lamp goes off. If not, check brake system for fluid leakage.

Drain and Refill

INFOID:000000004406688

CAUTION:

- Refill using recommended brake fluid.
- Never reuse drained brake fluid.
- Be careful not to splash brake fluid on painted areas; it may cause paint damage. If brake fluid is splashed on painted areas, immediately wipe them with cloth and wash it away with water.
- Before working, disconnect connectors of ABS actuator and electric unit (control unit) or battery negative terminal if equipped.

1. Connect a vinyl tube to bleed valve.
2. Depress the brake pedal, loosen the bleed valve, and gradually remove the brake fluid.

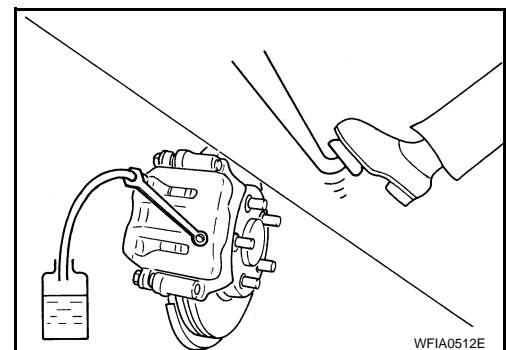

BRAKE FLUID

< SERVICE INFORMATION >

- Clean inside of reservoir tank, and refill with new brake fluid.
- Loosen bleed valve, depress brake pedal slowly to full stroke and then release it. Repeat the procedure every 2 or 3 seconds until the new brake fluid comes out, then close the bleed valve while depressing the brake pedal. Repeat the same procedure for each wheel.
- Bleed air. Refer to [BR-9, "Bleeding Brake System"](#).

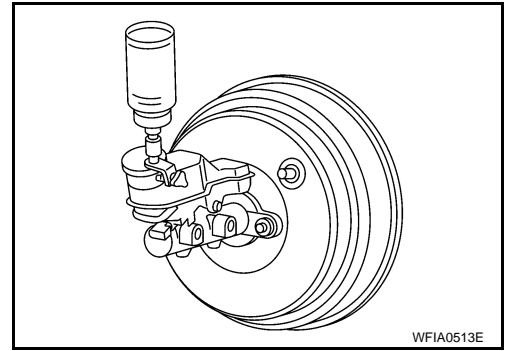

INFOID:000000004406689

Bleeding Brake System

CAUTION:

- While bleeding, pay attention to master cylinder fluid level.
 - Before working, disconnect connectors of ABS actuator and electric unit (control unit) or the battery negative terminal if equipped.
- Connect a vinyl tube to the rear right bleed valve.
 - Fully depress brake pedal 4 to 5 times.
 - With brake pedal depressed, loosen bleed valve to let the air out, and then tighten it immediately.
 - Repeat steps 2, 3 until no more air comes out.
 - Tighten bleed valve to specified torque. Refer to [BR-24, "Component"](#) (front disc brake), [BR-41, "Component"](#) (rear drum brake), [BR-33, "Component"](#) (rear disc brake).
 - Following the steps 1 to 5 above, with master cylinder reservoir tank filled at least half way, bleed air from the rear right, front left, rear left, and front right brake, in that order.

BRAKE TUBE AND HOSE

< SERVICE INFORMATION >

BRAKE TUBE AND HOSE

Hydraulic Circuit

INFOID:000000004406690

MR20DE without ABS

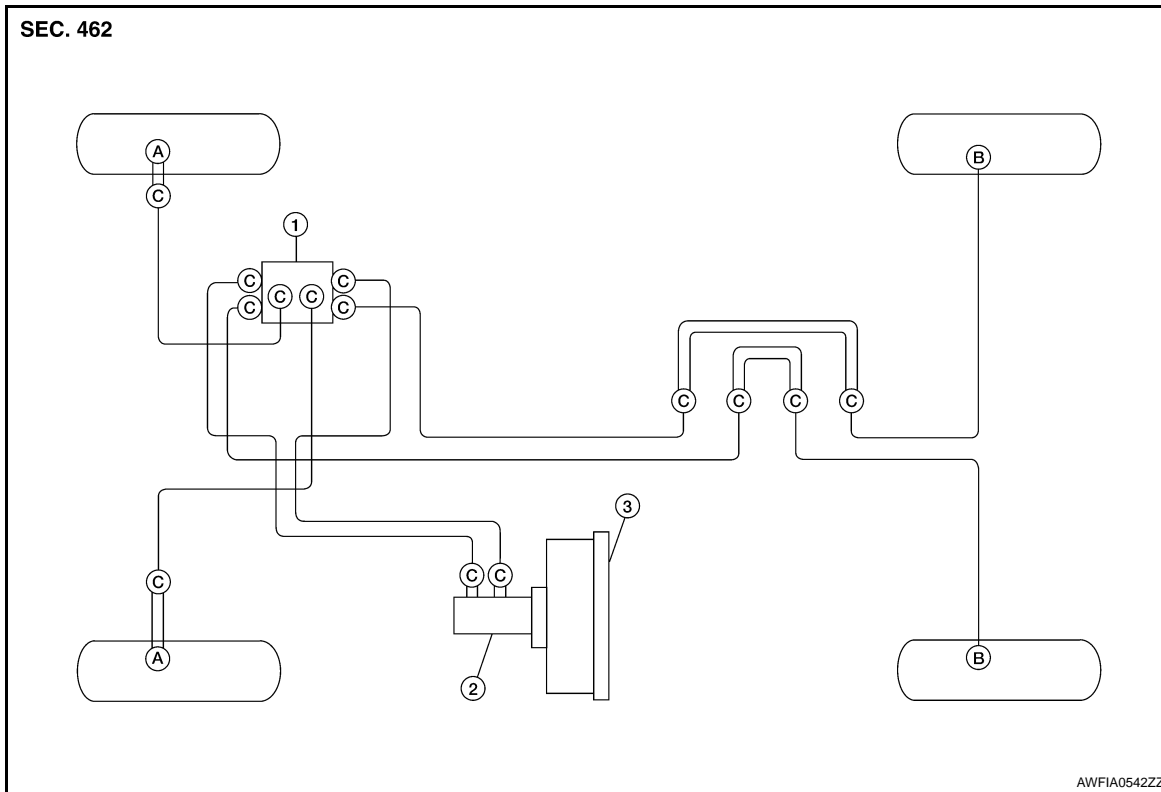

- | | | |
|---|---|---|
| 1. Dual proportioning valve | 2. Brake master cylinder | 3. Brake booster |
| A. Union bolt (front disc brake)
18 N·m (1.8 kg·m, 13 ft·lb) | B. Rear tube connector (rear drum brake)
16.5 N·m (1.7 kg·m, 12 ft·lb) | C. Flare nut
16.5 N·m (1.7 kg·m, 12 ft·lb) |
| — Brake tube | = Brake hose | |

BRAKE TUBE AND HOSE

< SERVICE INFORMATION >

MR20DE with ABS

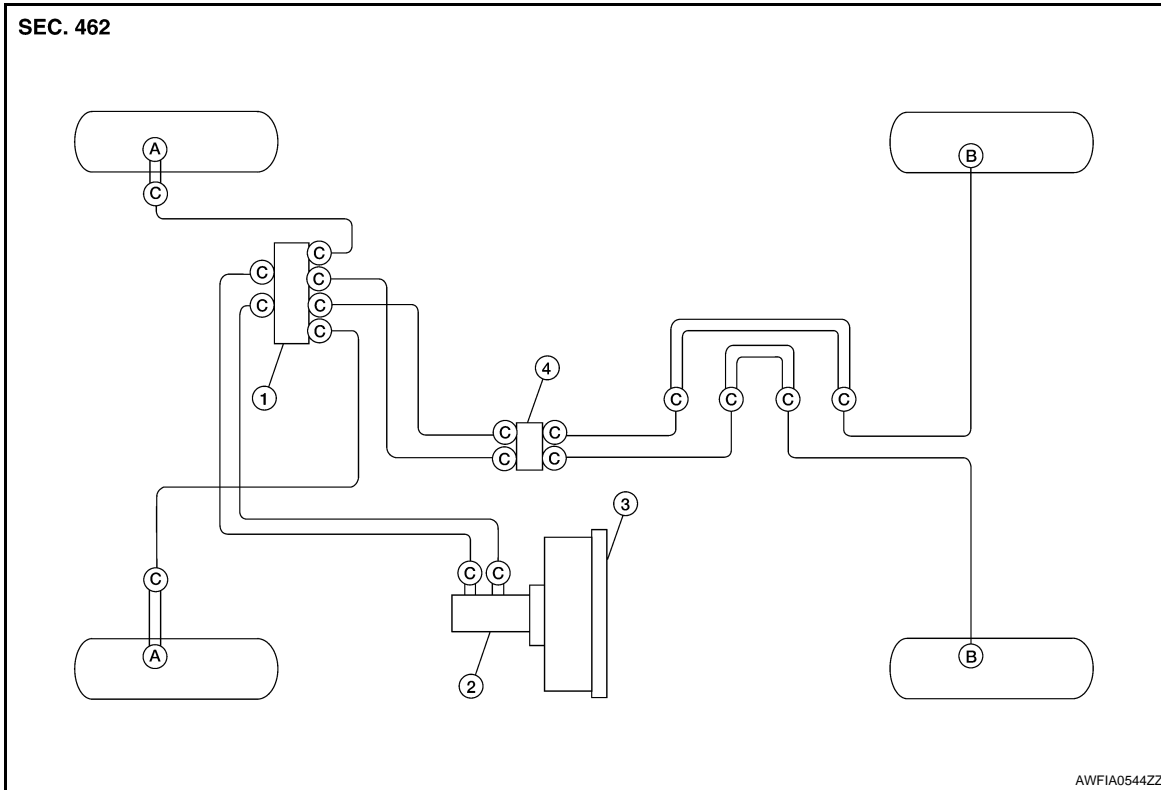

- | | | |
|--|---|---|
| 1. ABS actuator and electric unit (control unit) | 2. Brake master cylinder | 3. Brake booster |
| 4. Connector | A. Union bolt (front disc brake)
18 N·m (1.8 kg-m, 13 ft-lb) | B. Rear tube connector (rear drum brake)
16.5 N·m (1.7 kg-m, 12 ft-lb) |
| C. Flare nut
16.5 N·m (1.7 kg-m, 12 ft-lb) | - Brake tube | = Brake hose |

QR25DE with ABS

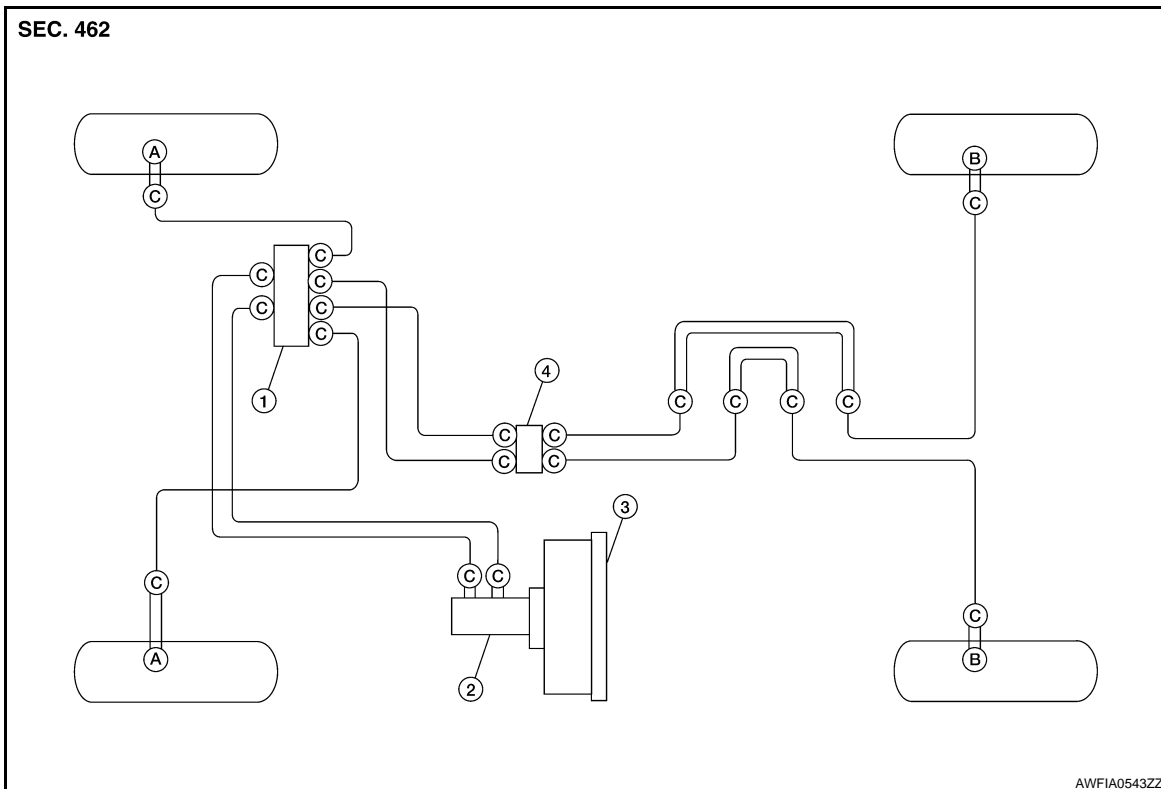

A
B
C
D
E
BR
G
H
I
J
K
L
M
N
O
P

BRAKE TUBE AND HOSE

< SERVICE INFORMATION >

- | | | |
|--|---|--|
| 1. ABS actuator and electric unit (control unit) | 2. Brake master cylinder | 3. Brake booster |
| 4. Connector | A. Union bolt (front disc brake)
18 N·m (1.8 kg-m, 13 ft-lb) | B. Union bolt (rear disc brake)
18.5 N·m (1.9 kg-m, 14 ft-lb) |
| C. Flare nut
16.5 N·m (1.7 kg-m, 12 ft-lb) | – Brake tube | = Brake hose |

CAUTION:

- All tubes and hoses must be free from excessive bending, twisting and pulling.
- Make sure there is no interference with other parts when turning steering both clockwise and counterclockwise.
- Brake tubes and hoses are an important safety part. Always disassemble the parts and retighten their fittings, if a brake fluid leak is detected. Replace applicable part with a new one, if damaged part is detected.
- Be careful not to splash brake fluid on painted areas; it may cause paint damage. If brake fluid is splashed on painted surfaces of body, immediately wipe them with cloth and then wash it away with water.
- Do not bend or twist brake hose sharply, or strongly pull it.
- When removing components, cover brake line connections so that dirt, dust, or other foreign matters do not get in.
- Refill using new recommended brake fluid.
- Never reuse drained brake fluid.

Front Brake Tube and Hose

INFOID:000000004406691

REMOVAL

CAUTION:

- Be careful not to splash brake fluid on painted areas; it may cause paint damage. If brake fluid is splashed on painted areas, wash it away with water immediately.
- Cover the open end of brake tubes and hoses when disconnecting to prevent entrance of dirt.

1. Drain brake fluid. Refer to [BR-8. "Drain and Refill"](#).
2. Remove brake tube from brake hose, using suitable tool.
3. Remove union bolt, and remove brake hose from caliper assembly.
4. Remove lock plate, and remove brake hose from vehicle.

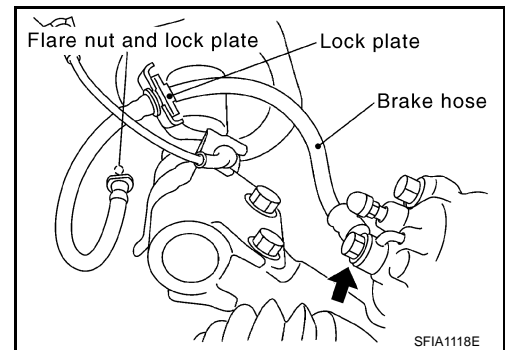

INSTALLATION

CAUTION:

- All brake hoses and tubes must be free from excessive bending, twisting and pulling.
- Make sure that there is no interference with other parts when turning steering both clockwise and counterclockwise.
- Brake tubes and hoses are an important safety part. Always disassemble the parts and retighten their fittings, if a brake fluid leak is detected. Replace applicable part with a new one, if damaged part is detected.
- Be careful not to splash brake fluid on painted areas; it may cause paint damage. If brake fluid is splashed on painted areas, wash it away with water immediately.
- Refill with new brake fluid "DOT 3".
- Never reuse drained brake fluid.

1. Assemble union bolt and copper washers to brake hose.

BRAKE TUBE AND HOSE

< SERVICE INFORMATION >

2. Position the L-shape metal fitting of the brake hose to the brake caliper assembly positioning hole.
3. Tighten union bolt to the specified torque. Refer to [BR-10, "Hydraulic Circuit"](#).
4. Connect brake hose to brake tube on vehicle, and temporarily tighten flare nut by hand as much as possible.
5. Secure it with lock plate.
6. Tighten flare nut to the specified torque using suitable tool. Refer to [BR-10, "Hydraulic Circuit"](#).
7. Install brake hose to vehicle, and tighten nuts to the specified torque.
8. Bleed air from brake system. Refer to [BR-9, "Bleeding Brake System"](#).

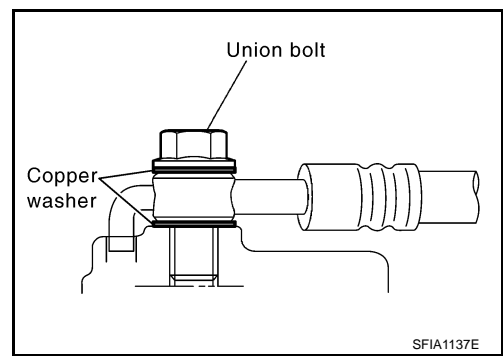

Rear Brake Tube and Hose

INFOID:000000004406692

OVER AXLE REAR BRAKE HOSE

Removal

CAUTION:

- Be careful not to splash brake fluid on painted areas; it may cause paint damage. If brake fluid is splashed on painted areas, wash it away with water immediately.
- Cover the open end of brake tubes and hoses when disconnecting to prevent entrance of dirt.

1. Drain brake fluid. Refer to [BR-8, "Drain and Refill"](#).
2. Remove brake tube from brake hose, using a suitable tool.
3. Remove lock plate, and remove brake hose.

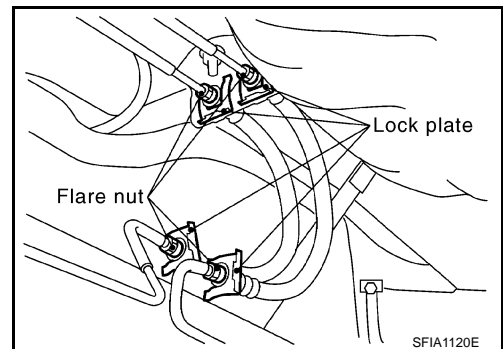

Installation

CAUTION:

- All brake hoses and tubes must be free from excessive bending, twisting and pulling.
- Make sure that there is no interference with other parts when turning steering both clockwise and counterclockwise.
- Brake tubes and hoses are an important safety part. Always disassemble the parts and retighten their fittings, if a brake fluid leak is detected. Replace applicable part with a new one, if damaged part is detected.
- Be careful not to splash brake fluid on painted areas; it may cause paint damage. If brake fluid is splashed on painted areas, wash it away with water immediately.
- Refill with new brake fluid "DOT 3".
- Never reuse drained brake fluid.

1. Connect brake hose to brake tube on vehicle, and temporarily tighten flare nut by hand as much as possible.
2. Secure it to bracket with lock plate.
3. Tighten flare nut to the specified torque using a suitable tool. Refer to [BR-10, "Hydraulic Circuit"](#).
4. Bleed air from brake system. Refer to [BR-9, "Bleeding Brake System"](#).

REAR BRAKE HOSE - QR25DE

Removal

CAUTION:

- Be careful not to splash brake fluid on painted areas; it may cause paint damage. If brake fluid is splashed on painted areas, wash it away with water immediately.
- Cover the open end of brake tubes and hoses when disconnecting to prevent entrance of dirt.

BRAKE TUBE AND HOSE

< SERVICE INFORMATION >

1. Drain the brake fluid. Refer to [BR-8. "Drain and Refill"](#).
2. Disconnect the brake hose from brake tube, using a flare nut wrench and then remove the lock plate.

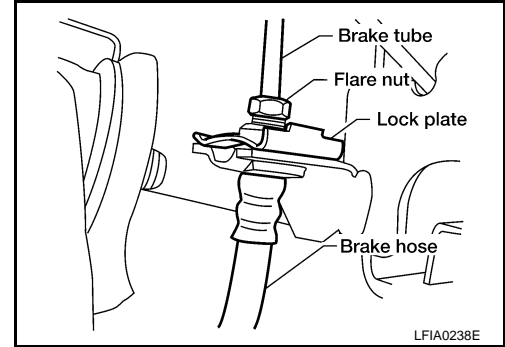

3. Remove the union bolt (A), and then remove brake hose from brake caliper assembly and discard the copper washers.

CAUTION:

Do not reuse the copper washers.

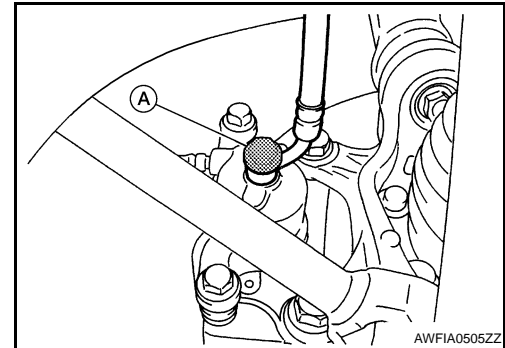

4. Remove the brake hose.

Installation

CAUTION:

- All brake hoses and tubes must be free from excessive bending, twisting and pulling.
- Make sure that there is no interference with other parts when turning steering both clockwise and counterclockwise.
- Brake tubes and hoses are an important safety part. Always disassemble the parts and retighten their fittings, if a brake fluid leak is detected. Replace applicable part with a new one, if damaged part is detected.
- Be careful not to splash brake fluid on painted areas; it may cause paint damage. If brake fluid is splashed on painted areas, wash it away with water immediately.
- Refill with new brake fluid "DOT 3".
- Never reuse drained brake fluid.

1. Assemble the union bolt and the new copper washers on the brake hose.

CAUTION:

Do not reuse the copper washers.

2. Attach L-shape metal fitting of the brake hose to brake caliper assembly positioning hole, and then tighten union bolt to the specified torque.

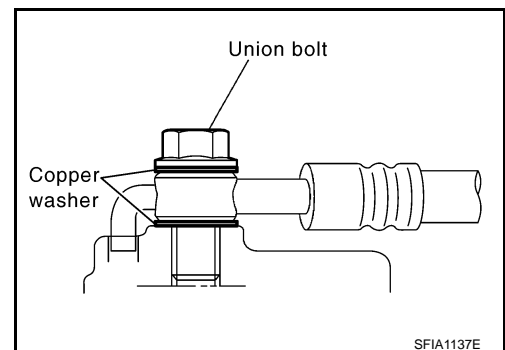

BRAKE TUBE AND HOSE

< SERVICE INFORMATION >

3. Connect brake hose to brake tube, partially tighten flare nut by hand as much as possible, then secure it to the bracket with lock plate.
4. Using a flare nut torque wrench, tighten flare nut to the specified torque.
5. Refill brake fluid and bleed air. Refer to [BR-9, "Bleeding Brake System"](#).

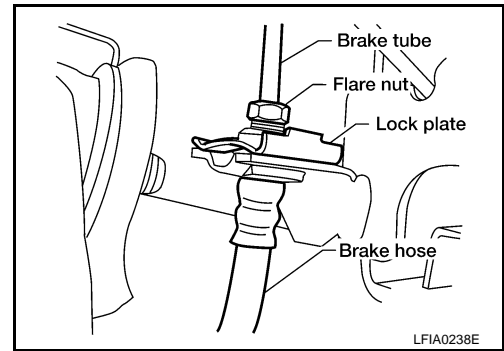

Inspection After Installation

INFOID:000000004406693

CAUTION:

- Always disassemble the parts and retighten their fittings, if a brake fluid leak is detected. Replace applicable part with a new one, if damaged part is detected.
 - If leak is detected at the connections, retighten it or replace the damaged part.
1. Check brake hose, tube, and connections for fluid leaks, damage, twist, deformation, contact with other parts, and loose connections.
 2. While depressing pedal under a force of 785 N (80 kg-f, 177 lb-f) with the engine running for approximately 5 seconds, check for fluid leak from each part.

DUAL PROPORTIONING VALVE

< SERVICE INFORMATION >

DUAL PROPORTIONING VALVE

Removal and Installation

INFOID:000000004406694

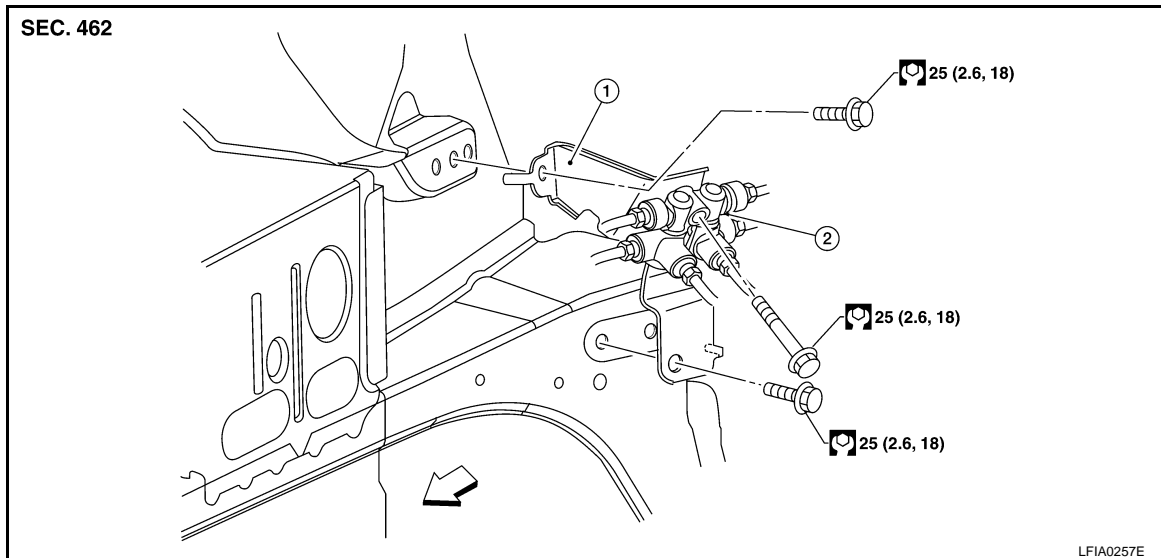

1. Dual proportioning valve bracket 2. Dual proportioning valve ← Front

Removal

CAUTION:

Be careful not to splash brake fluid on painted areas; it may cause paint damage. If brake fluid is splashed on paint areas, wash it away with water immediately.

1. Drain the brake fluid. Refer to [BR-8, "Drain and Refill"](#).
2. Disconnect brake lines from dual proportioning valve.
 - Mark brake lines for installation.
3. Remove dual proportioning valve bolt and dual proportioning valve.
4. Remove two bolts and bracket.

Installation

Installation is in the reverse order of removal.

- When installing brake lines to the dual proportioning valve, tighten to specifications. Refer to [BR-10, "Hydraulic Circuit"](#).
- Refill and bleed the brake system. Refer to [BR-9, "Bleeding Brake System"](#).

CAUTION:

- Carefully monitor brake fluid level at master cylinder.
- Use the recommended new brake fluid.
- Be careful not to splash brake fluid on painted areas; it may cause paint damage. If brake fluid is splashed on paint areas, wash it away with water immediately.

Inspection

INFOID:000000004406695

CAUTION:

- Carefully monitor brake fluid level at master cylinder.
- Use the recommended new brake fluid.
- Be careful not to splash brake fluid on painted areas; it may cause paint damage. If brake fluid is splashed on paint areas, wash it away with water immediately.

DUAL PROPORTIONING VALVE

< SERVICE INFORMATION >

1. Connect commercially available brake fluid pressure gauge to air bleeders of front and rear brakes on either LH and RH side.

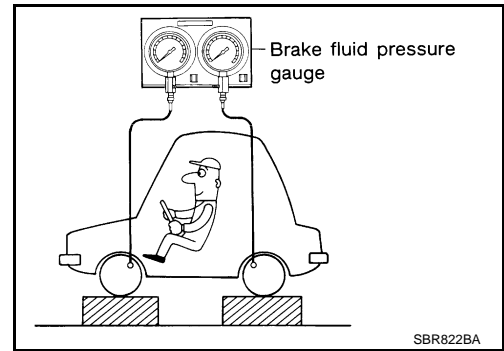

2. Bleed air from the Tool.
3. Check fluid pressure by depressing brake pedal. Refer to [BR-47, "Dual Proportioning Valve"](#).
 - If output pressure is out of specification, replace dual proportioning valve.

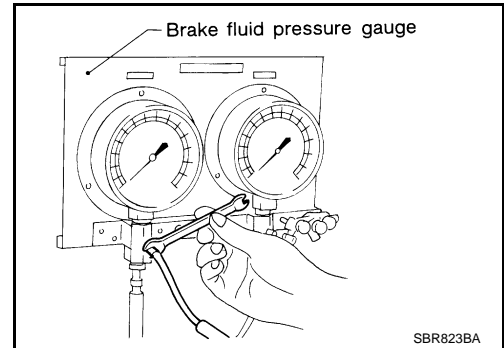

4. Bleed air after disconnecting the Tool. Refer to [BR-9, "Bleeding Brake System"](#).

A
B
C
D
E
BR
G
H
I
J
K
L
M
N
O
P

BRAKE MASTER CYLINDER

< SERVICE INFORMATION >

BRAKE MASTER CYLINDER

On-Board Inspection

INFOID:000000004406696

LEAK INSPECTION

Check for leaks in a master cylinder installation surface, the reservoir tank installation surface, and the brake tube connections. Repair or replace components as necessary.

Removal and Installation

INFOID:000000004406697

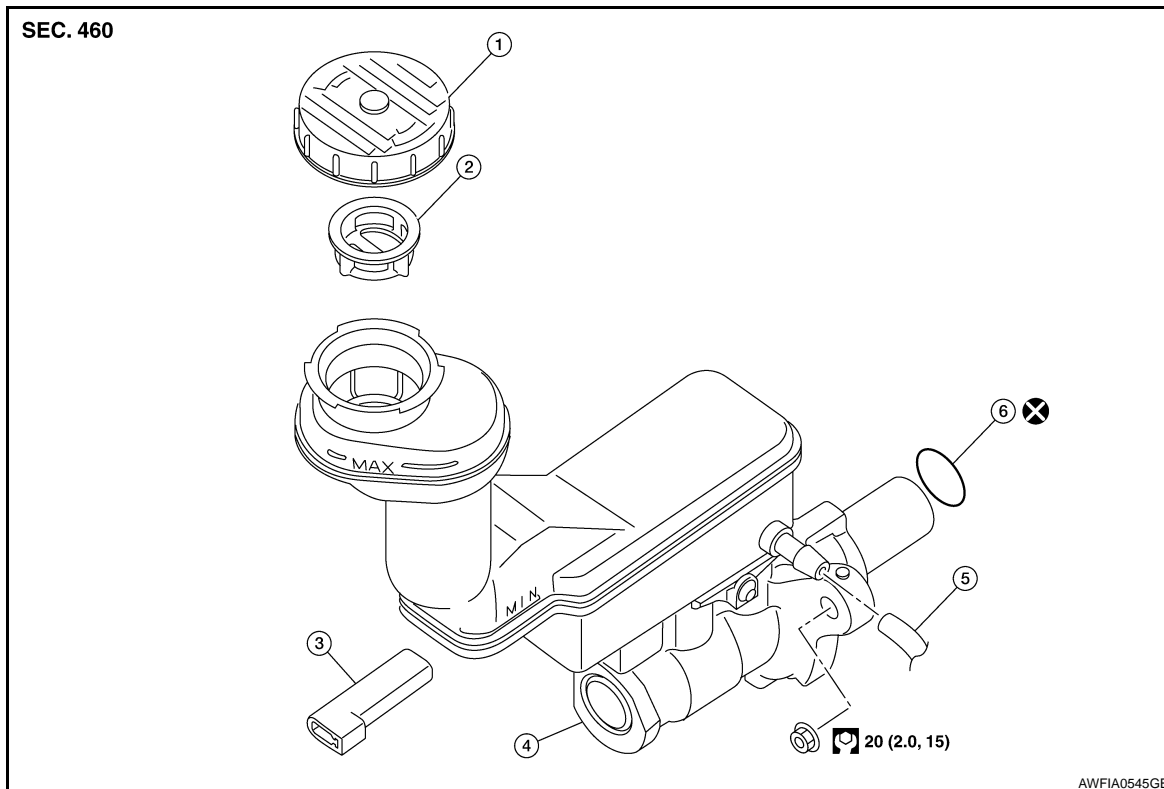

- | | | |
|---|---|---------------------------------------|
| 1. Reservoir cap | 2. Filter | 3. Brake fluid level switch connector |
| 4. Master cylinder and reservoir assembly | 5. Hose to clutch master cylinder (if equipped) | 6. O-ring |

CAUTION:

Be careful not to splash brake fluid on painted areas; it may cause paint damage. If brake fluid is splashed on painted areas, immediately wipe them with cloth and wash it away with water.

REMOVAL

1. Drain the brake fluid. Refer to [BR-8, "Drain and Refill"](#).
2. Remove the battery. Refer to [SC-6, "Removal and Installation MR20DE"](#), [SC-7, "Removal and Installation QR25DE"](#).
3. Remove the air cleaner and air duct. Refer to [EM-16, "Removal and Installation" \(MR20DE\)](#), [EM-131, "Removal and Installation" \(QR25DE\)](#).
4. Disconnect the brake fluid level switch harness connector.
5. Disconnect the hose to clutch master cylinder (if equipped) from the brake fluid reservoir.
6. Remove the brake tubes from master cylinder using a suitable tool.
7. Remove the master cylinder and reservoir assembly nuts, and remove the master cylinder and reservoir assembly.

INSTALLATION

CAUTION:

BRAKE MASTER CYLINDER

< SERVICE INFORMATION >

- Refill using recommended brake fluid.
- Never reuse drained brake fluid.
- Check if the rod of primary piston has dust or scratches.

1. Install master cylinder and reservoir assembly to brake booster assembly, and tighten master cylinder and reservoir assembly nuts to the specified torque.

CAUTION:

- Do not damage or strain rod of primary piston.
- Apply silicone grease for O-ring, primary piston rod and to inside of booster.

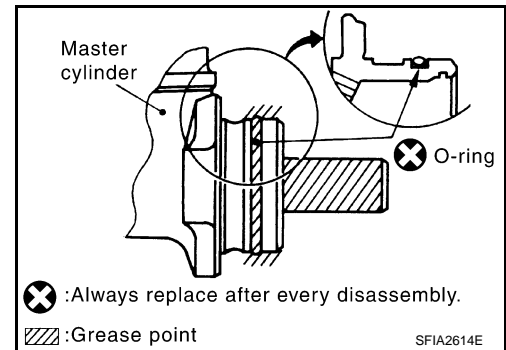

2. Install brake tubes to master cylinder, then tighten flare nuts to the specified torque using a suitable tool. Refer to [BR-10, "Hydraulic Circuit"](#).
3. Connect the hose to clutch master cylinder (if equipped) from the brake fluid reservoir.
4. Connect brake fluid level switch harness connector and clutch master cylinder hose (if equipped).
5. Install the air cleaner and air duct. Refer to [EM-16, "Removal and Installation"](#) (MR20DE), [EM-131, "Removal and Installation"](#) (QR25DE).
6. Install the battery. Refer to [SC-6, "Removal and Installation MR20DE"](#), [SC-7, "Removal and Installation QR25DE"](#).
7. Refill with new brake fluid and bleed air. Refer to [BR-9, "Bleeding Brake System"](#).

BRAKE BOOSTER

< SERVICE INFORMATION >

BRAKE BOOSTER

On Board Inspection

INFOID:000000004406698

OPERATING CHECK

- With the engine stopped, change the vacuum to the atmospheric pressure by depressing brake pedal several times at intervals of 5 seconds.
- Then with brake pedal fully depressed, start engine and when the vacuum pressure reaches the standard, make sure that the clearance between brake pedal and floor panel decreases.

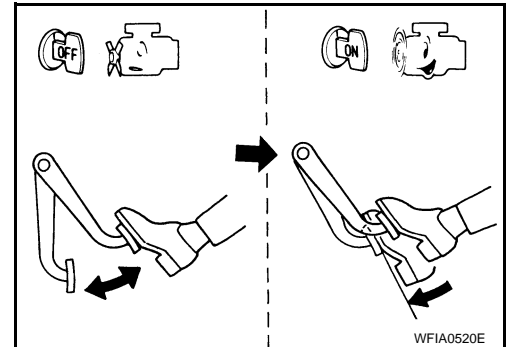

AIRTIGHT CHECK

- Run engine at idle for approximately 1 minute, and stop it after applying vacuum to booster. Depress brake pedal normally to change the vacuum to the atmospheric pressure. Make sure that distance between brake pedal and floor panel gradually increases.
- Depress the brake pedal while engine is running, then stop engine with brake pedal depressed. The pedal stroke should not change after holding pedal down for 30 seconds.

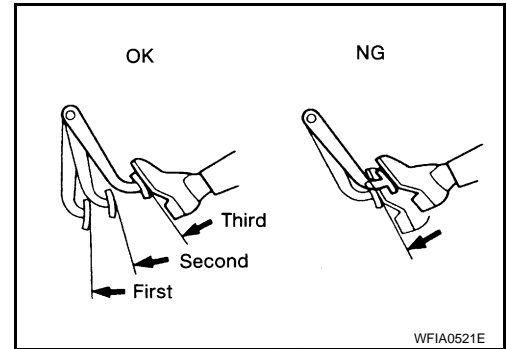

Removal and Installation

INFOID:000000004406699

COMPONENTS

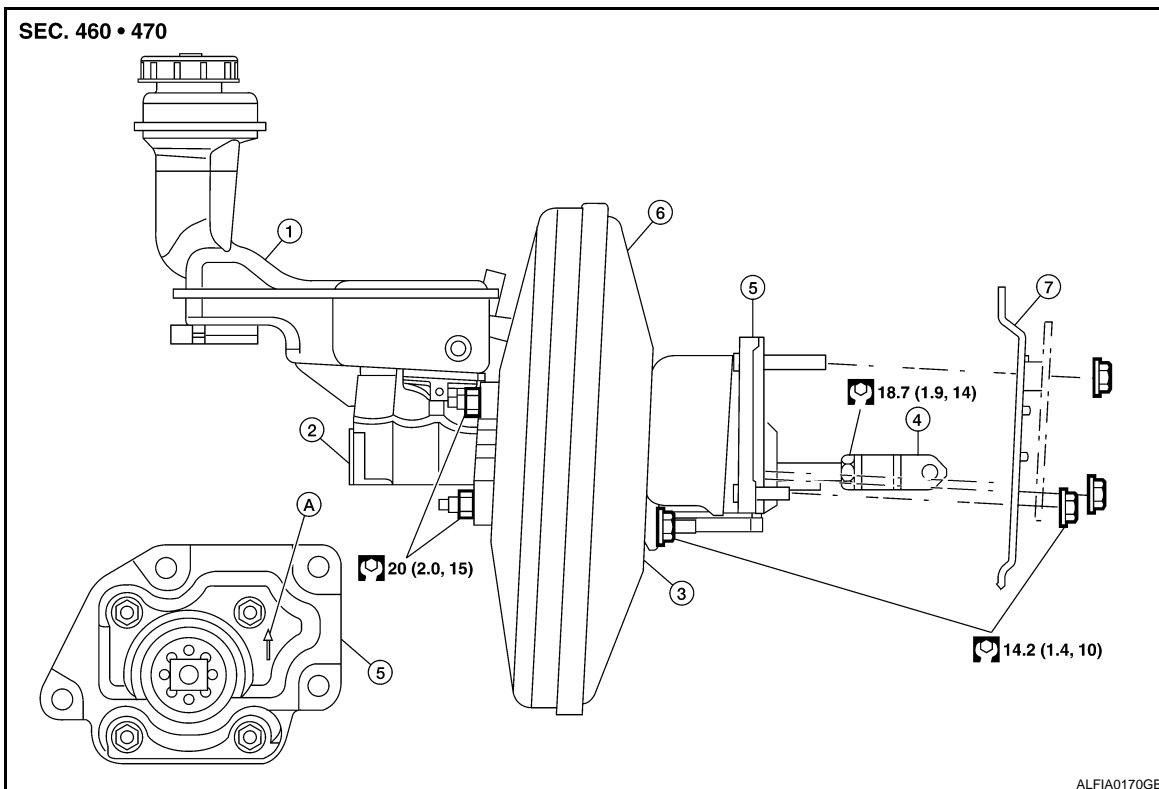

BR-20

BRAKE BOOSTER

< SERVICE INFORMATION >

- | | | |
|------------------------|--------------------|------------------|
| 1. Reservoir tank | 2. Master cylinder | 3. Gasket |
| 4. Clevis | 5. Spacer | 6. Brake booster |
| 7. Lower dash assembly | A. Up mark | |

REMOVAL

CAUTION:

- Be careful not to splash brake fluid on painted areas such as body. If brake fluid is splashed on painted surfaces of body, wipe them with cloth immediately and then wash it away with water.
- Be careful not to deform or bend brake tubes while removing and installing brake booster.
- Replace clevis pin if it is damaged.
- Be careful not to damage brake booster stud bolt threads. If brake booster is tilted or inclined during installation, dash panel may damage the threads.

1. Remove vacuum hose from brake booster. Refer to [BR-22, "Removal and Installation"](#).
2. Remove master cylinder assembly. Refer to [BR-18, "Removal and Installation"](#).
3. Remove snap pin and clevis pin from the clevis of the input rod, and disconnect clevis from brake pedal.
4. Remove the three brake pedal nuts from lower dash assembly.
5. Remove the spacer nut from lower dash assembly.
6. Remove brake booster and spacer.
7. Remove brake booster nuts and remove spacer from brake booster.

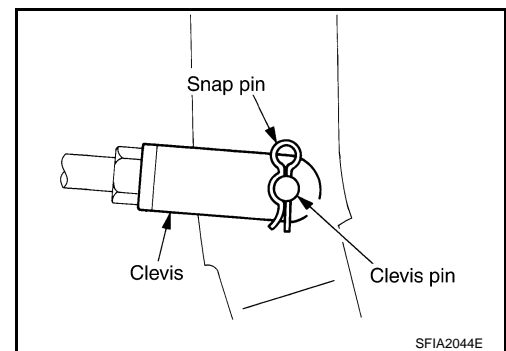

INSTALLATION

1. Loosen lock nut to adjust input rod length so that the length B satisfies the specified value.

Length "B" : Refer to [BR-47, "Brake Booster"](#).

2. Install spacer with new gasket to brake booster and tighten spacer nut (brake booster side) to the specified torque.
3. After adjusting length "B", temporarily tighten lock nut to install brake booster assembly to lower dash assembly. At this time, make sure to install a gasket between brake booster and lower dash assembly.

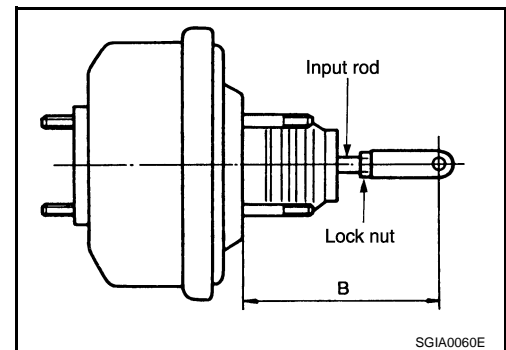

CAUTION:

Be sure to install the gasket between brake booster and lower dash assembly.

4. Connect brake pedal to clevis of input rod with the clevis pin and snap pin.
5. Install the three brake pedal bracket nuts and tighten them to the specified torque.
6. Install the spacer nut and tighten to the specified torque.
7. Adjust the height of brake pedal. Refer to [BR-5, "Inspection and Adjustment"](#).
8. Tighten lock nut for the input rod to the specified torque.
9. Install vacuum hose into brake booster. Refer to [BR-22, "Removal and Installation"](#).
10. Install master cylinder assembly. Refer to [BR-18, "Removal and Installation"](#).
11. Refill with new brake fluid and bleed air from brake system. Refer to [BR-9, "Bleeding Brake System"](#).

VACUUM LINES

< SERVICE INFORMATION >

VACUUM LINES

Component

INFOID:000000004406700

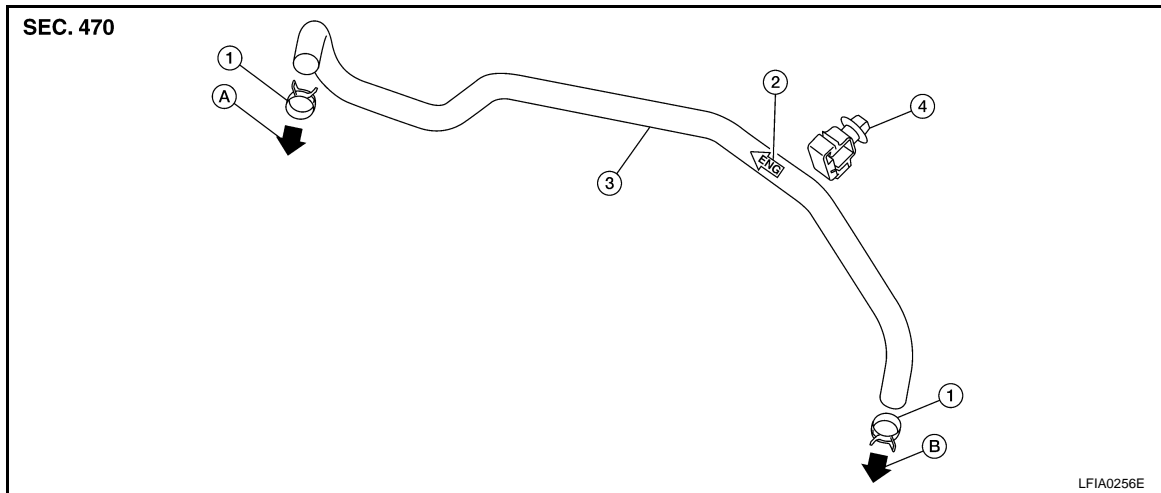

- | | | |
|----------|---|---------------------|
| 1. Clamp | 2. Engine side indicator stamp (for built-in check valve) | 3. Vacuum hose |
| 4. Clip | A. To intake manifold | B. To brake booster |

Removal and Installation

INFOID:000000004406701

REMOVAL

1. Disconnect the vacuum hose from the brake booster.
2. Disconnect the vacuum hose from the engine intake manifold.
3. Remove the vacuum hose.

INSTALLATION

Installation is in the reverse order of removal.

- Inspect the vacuum hose and internal one-way check valve before installation. Refer to [BR-22, "Inspection"](#).

CAUTION:

- **Because the vacuum hose contains a one-way check valve, the hose must be installed in the correct position. Refer to the stamp on the hose to confirm the correct direction for installation. The brake booster will not operate normally if the hose is installed in the wrong direction.**
- **Do not use lubricating oil during assembly.**
- **Insert the vacuum hose at least 24 mm (0.94 in) onto the brake booster fitting as shown.**

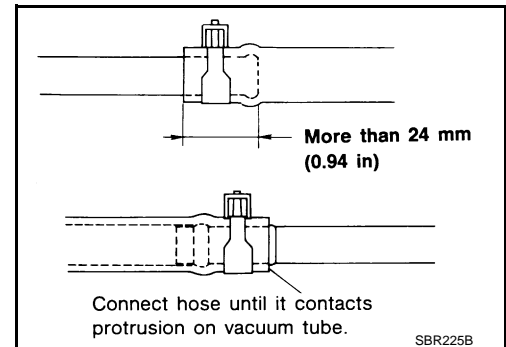

Inspection

INFOID:000000004406702

VISUAL INSPECTION

Check for improper installation, damage and aging. Reinstall or replace the vacuum hose with the internal check valve as necessary.

CHECK VALVE INSPECTION

VACUUM LINES

< SERVICE INFORMATION >

- Use a hand vacuum pump to inspect the vacuum hose and internal check valve. Replace the vacuum hose and internal check valve if not within specifications.

When connected to booster side (1) Refer to [BR-47, "Check Valve"](#).

When connected to engine side (2) Refer to [BR-47, "Check Valve"](#).

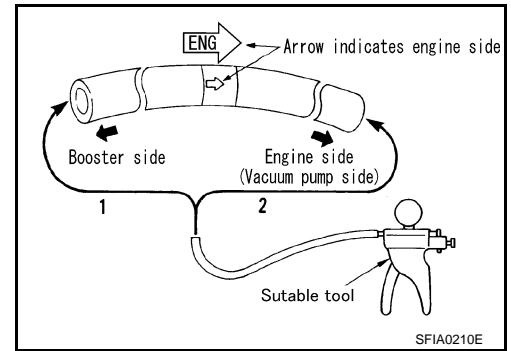

- Replace the vacuum hose with the internal check valve if the vacuum hose is damaged or deformed.

A
B
C
D
E
BR
G
H
I
J
K
L
M
N
O
P

FRONT DISC BRAKE

< SERVICE INFORMATION >

FRONT DISC BRAKE

On Board Inspection

INFOID:000000004406703

PAD WEAR INSPECTION

Inspect pad thickness from check hole in cylinder body. Refer to [BR-47, "Front Disc Brake"](#).

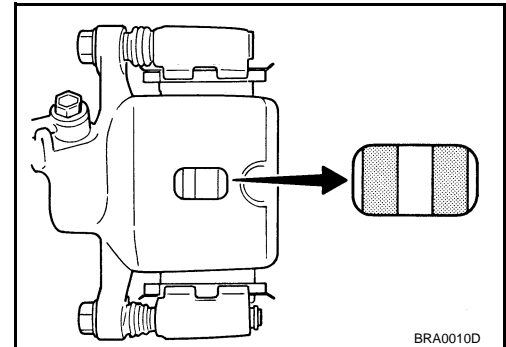

BRA0010D

Component

INFOID:000000004406704

Front Disc Brakes - MR20DE (All Models) & QR25DE (SE-R)

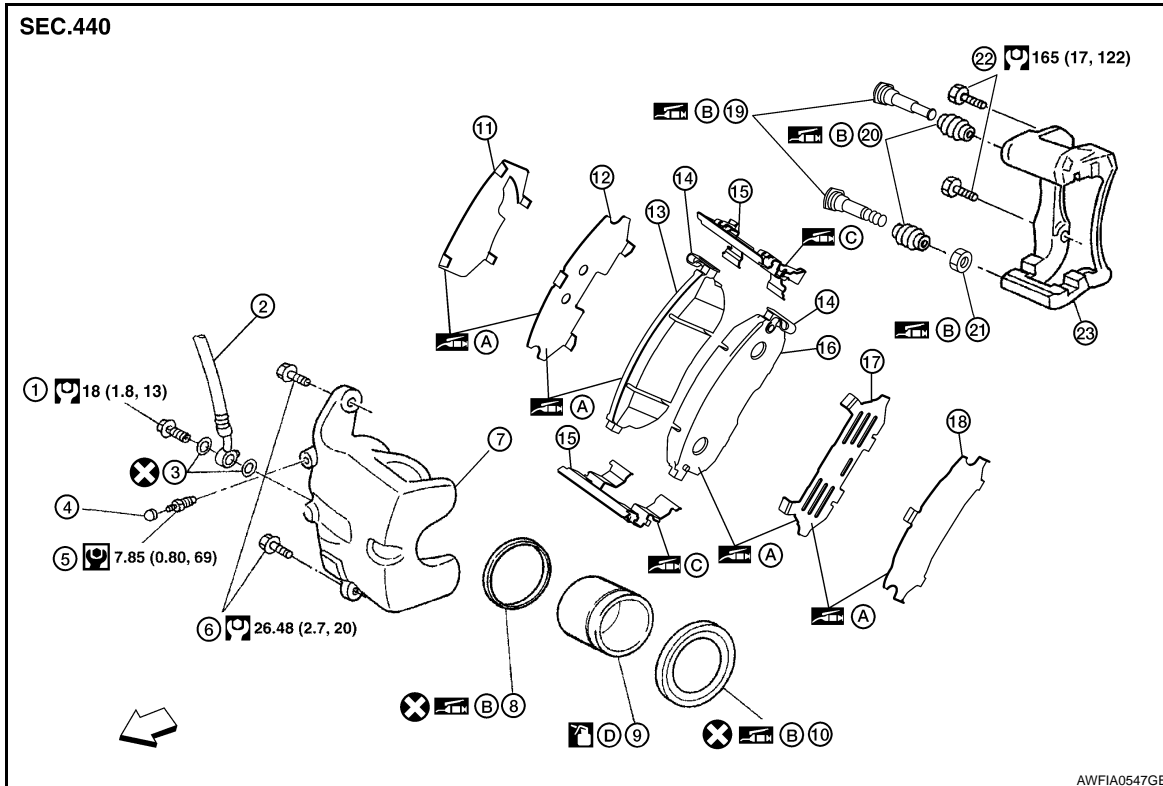

- | | | |
|-------------------------|----------------------|----------------------|
| 1. Union bolt | 2. Brake hose | 3. Copper washer |
| 4. Cap | 5. Bleed valve | 6. Sliding pin bolt |
| 7. Cylinder body | 8. Piston seal | 9. Piston |
| 10. Piston boot | 11. Inner shim cover | 12. Inner shim |
| 13. Inner pad | 14. Pad wear sensor | 15. Pad retainer |
| 16. Outer pad | 17. Outer shim | 18. Outer shim cover |
| 19. Sliding pin | 20. Sliding pin boot | 21. Bushing |
| 22. Torque member bolt | 23. Torque member | ← Front |
| A. Molykote M-77 grease | B. Rubber grease | C. M-7439 grease |
| D. Brake fluid | | |

FRONT DISC BRAKE

< SERVICE INFORMATION >

Front Disc Brakes - QR25DE (SE-R SPEC -V)

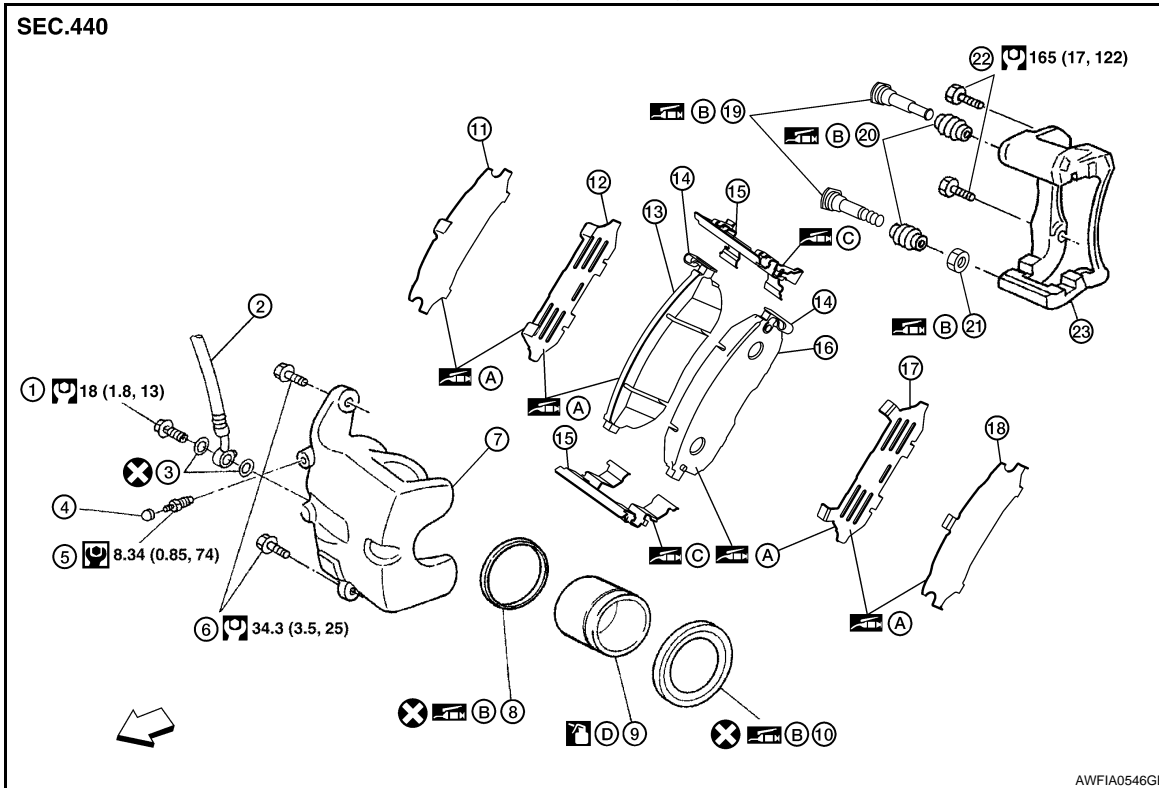

- | | | |
|-------------------------|----------------------|----------------------|
| 1. Union bolt | 2. Brake hose | 3. Copper washer |
| 4. Cap | 5. Bleed valve | 6. Sliding pin bolt |
| 7. Cylinder body | 8. Piston seal | 9. Piston |
| 10. Piston boot | 11. Inner shim cover | 12. Inner shim |
| 13. Inner pad | 14. Pad wear sensor | 15. Pad retainer |
| 16. Outer pad | 17. Outer shim | 18. Outer shim cover |
| 19. Sliding pin | 20. Sliding pin boot | 21. Bushing |
| 22. Torque member bolt | 23. Torque member | ⇐ Front |
| A. Molykote M-77 grease | B. Rubber grease | C. M-7439 grease |
| D. Brake fluid | | |

CAUTION:

Clean dust with a vacuum dust collector. Do not blow with compressed air.

Removal and Installation of Brake Pad

INFOID:000000004406705

WARNING:

Clean dust on caliper and brake pad with a vacuum dust collector to minimize the hazard of air borne particles or other materials.

CAUTION:

- While removing caliper, do not depress brake pedal because piston will pop out.
- It is not necessary to remove bolts on torque member and brake hose except for disassembly or replacement of caliper assembly. In this case, hang caliper with a wire so as not to stretch brake hose.
- Do not damage piston boot.
- If any shim is subject to serious corrosion, replace it with a new one.
- Always replace shim and shim cover as a set when replacing brake pads.
- Keep rotor free from brake fluid.
- Burnish the brake pads and disc rotor mutually contacting surfaces, after refinishing or replacing rotors, after replacing pads, or if a soft pedal occurs at very low mileage. Refer to [WT-8, "Rotation"](#).

REMOVAL

FRONT DISC BRAKE

< SERVICE INFORMATION >

1. Drain a quarter of the brake fluid from the reservoir.
2. Remove front wheels and tires using power tools.
3. Remove lower sliding pin bolt.

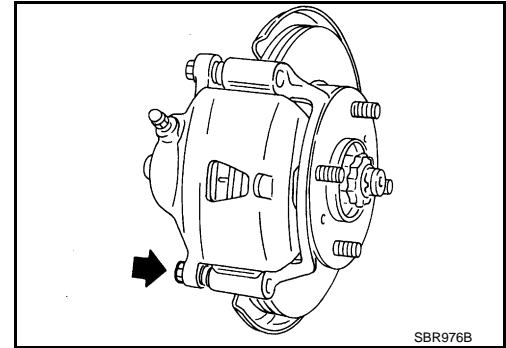

4. Swing cylinder body up and support cylinder body with a suitable wire as shown. Remove pads, shims and pad retainers from torque member.

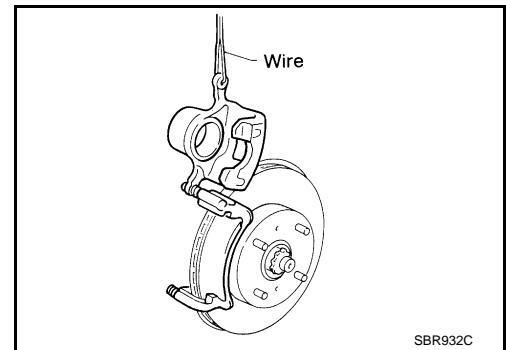

CAUTION:

When removing pad retainer from torque member, lift pad retainer in the direction shown by arrow, so as not to deform it.

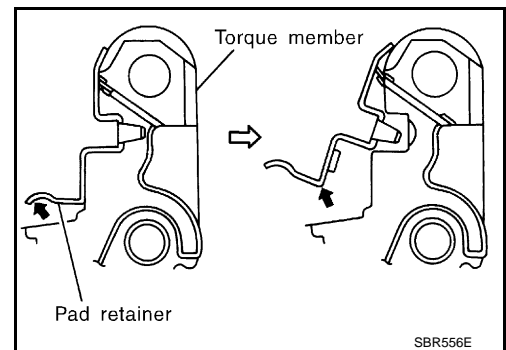

INSTALLATION

1. Apply Molykote M-77 grease or equivalent to the shims. Install shims to pads.

CAUTION:

Securely install shims according to mounting direction of pads.

2. Apply Molykote M-7439 grease or equivalent to pad contact surfaces (A) on pad retainers. Install pad retainers and pads to the torque member.

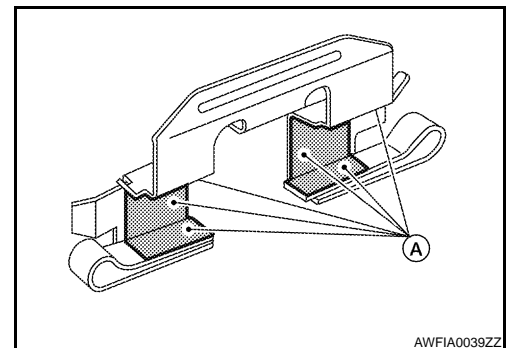

CAUTION:

FRONT DISC BRAKE

< SERVICE INFORMATION >

- When installing pad retainer, attach it firmly so that it is not lifted up from torque member, as shown.

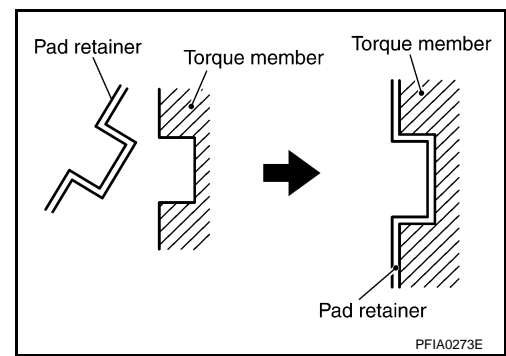

- If equipped, both inner and outer pads have a pad return system on the pad retainer. Install pad return lever securely to pad wear sensor.

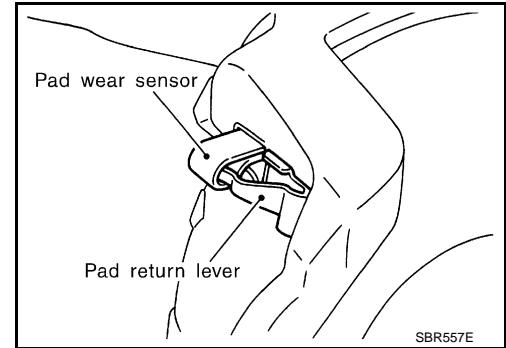

3. Install the cylinder body to torque member.
 - Press the piston into the cylinder body using a suitable tool.**CAUTION:**
Check the brake fluid level in the reservoir tank because brake fluid returns to master cylinder reservoir tank when pressing piston in.
4. Install lower sliding pin bolt, and tighten to the specified torque. Refer to [BR-24. "Component"](#).

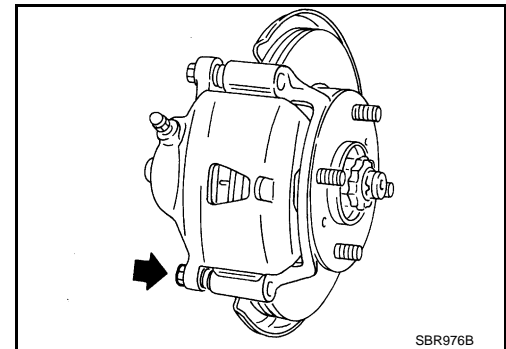

5. Check front brakes for drag.
6. Install front wheels and tires. Refer to [WT-8. "Rotation"](#).

Removal and Installation of Brake Caliper Assembly

INFOID:000000004406706

WARNING:

Clean dust on caliper and brake pad with a vacuum dust collector to minimize the hazard of air borne particles or other materials.

CAUTION:

- While removing caliper, do not depress brake pedal because piston will pop out.
- It is not necessary to remove bolts on torque member and brake hose except for disassembly or replacement of caliper assembly. In this case, hang caliper with a wire so as not to stretch brake hose.
- Do not damage piston boot.
- If any shim is subject to serious corrosion, replace it with a new one.
- Always replace shim and shim cover as a set when replacing brake pads.
- Keep rotor free from brake fluid.

FRONT DISC BRAKE

< SERVICE INFORMATION >

- Burnish the brake pads and disc rotor mutually contacting surfaces, after refinishing or replacing rotors, after replacing pads, or if a soft pedal occurs at very low mileage. Refer to [BR-32, "Brake Burnishing"](#).

REMOVAL

1. Drain a quarter of the brake fluid from the reservoir.
2. Remove front wheels and tires using power tools.
3. Secure disc rotor using wheel nuts.
4. Remove union bolt (A), and then disconnect brake hose from cylinder body. Discard the copper washers.

- Protusions (B)

CAUTION:

Do not reuse the copper washers.

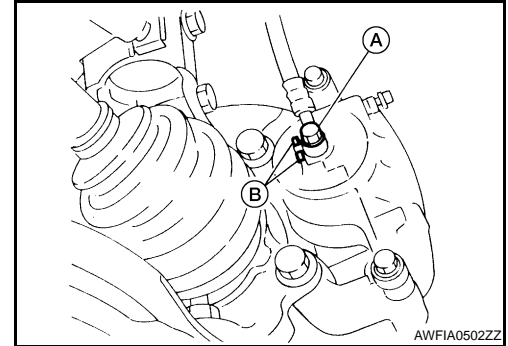

5. Remove sliding pin bolts (A) and remove cylinder body from torque member.

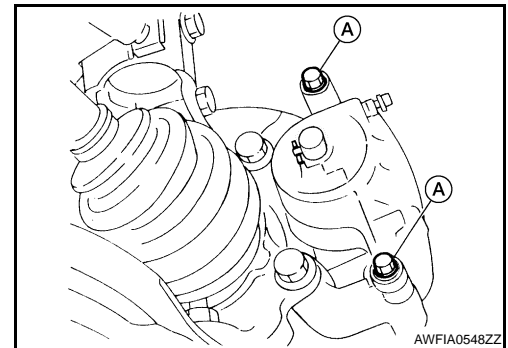

6. If necessary, apply matching marks then remove wheel nuts and remove disc rotor.

CAUTION:

Put matching marks on wheel hub assembly and disc rotor as shown, if it is necessary to remove disc rotor.

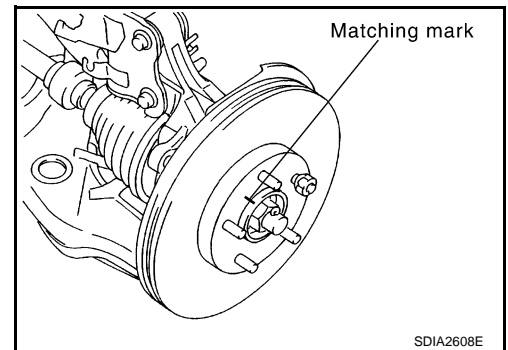

INSTALLATION

1. If removed, install disc rotor and secure using wheel nuts.

CAUTION:

Follow matching marks on wheel hub assembly and disc rotor for installation as shown.

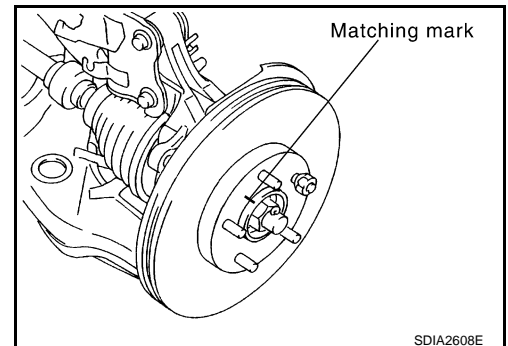

FRONT DISC BRAKE

< SERVICE INFORMATION >

2. Install cylinder body on sliding pins, and tighten sliding pin bolts (A) to the specified torque. Refer to [BR-24, "Component"](#).

CAUTION:

Before installing cylinder body, wipe off all oil and grease on mounting surface of torque member.

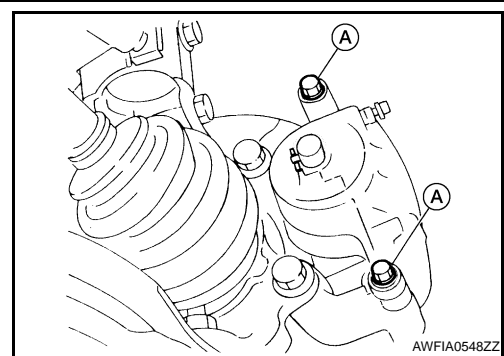

3. Install brake hose to cylinder body with new copper washers. Align the brake hose tab between the protusions (B) on the cylinder body as shown. Tighten the union bolt (A) to specification. Refer to [BR-10, "Hydraulic Circuit"](#).

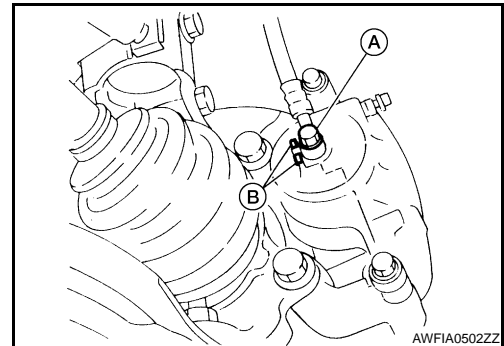

CAUTION:

Do not reuse copper washers.

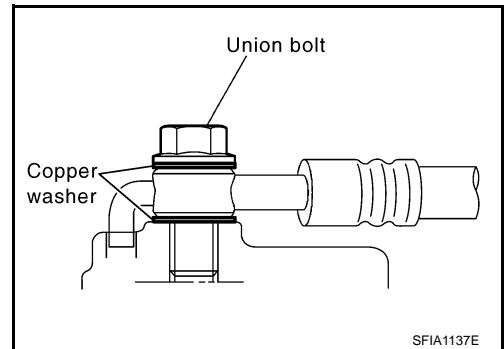

4. Check front disc brake for drag.
5. Bleed the brake system. Refer to [BR-9, "Bleeding Brake System"](#).
6. Install front wheels and tires. Refer to [WT-8, "Rotation"](#).

Disassembly and Assembly of Brake Caliper Assembly

INFOID:000000004406707

WARNING:

Clean dust on caliper and brake pad with a vacuum dust collector to minimize the hazard of air borne particles or other materials.

CAUTION:

- While removing caliper, do not depress brake pedal because piston will pop out.
- It is not necessary to remove bolts on torque member and brake hose except for disassembly or replacement of caliper assembly. In this case, hang caliper with a wire so as not to stretch brake hose.
- Do not damage piston boot.
- If any shim is subject to serious corrosion, replace it with a new one.
- Always replace shim and shim cover as a set when replacing brake pads.
- Keep rotor free from brake fluid.
- Burnish the brake pads and disc rotor mutually contacting surfaces, after refinishing or replacing rotors, after replacing pads, or if a soft pedal occurs at very low mileage. Refer to [BR-32, "Brake Burnishing"](#).

NOTE:

FRONT DISC BRAKE

< SERVICE INFORMATION >

Do not remove torque member, brake pads, shims and pad retainers, when disassembling or assembling cylinder body.

DISASSEMBLY

1. Remove cylinder body from the torque member. Refer to [BR-27, "Removal and Installation of Brake Caliper Assembly"](#).
2. Place a wooden block as shown, and blow air from union bolt hole to remove piston and piston boot. Discard the piston boot.

WARNING:

Do not place your finger in front of piston.

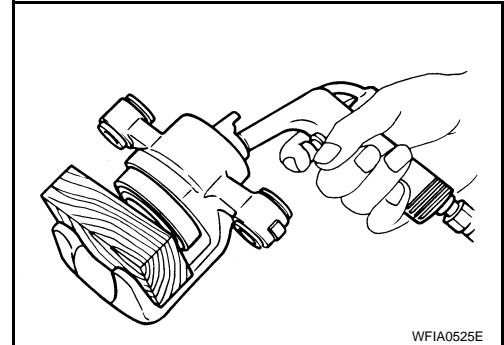

3. Remove piston seal using a suitable tool. Discard the piston seal.

CAUTION:

Be careful not to damage the inner wall of cylinder body.

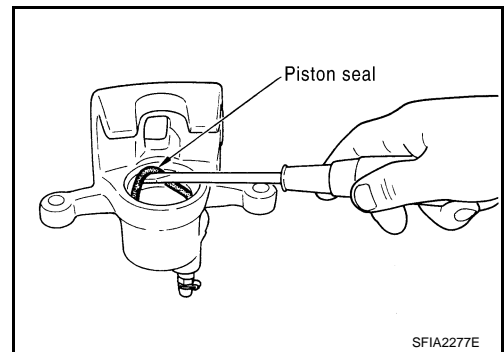

INSPECTION AFTER DISASSEMBLY

Cylinder Body

Check the inner wall of cylinder for corrosion, wear, and damage. Replace cylinder body as necessary.

CAUTION:

Clean cylinder body using new brake fluid. Never use mineral oils such as gasoline or kerosene.

Torque Member

Check for wear, cracks, and damage. Replace torque member as necessary.

Piston

Check piston surface for corrosion, wear, and damage. Replace piston as necessary.

CAUTION:

The piston sliding surface is plated. Do not polish with sandpaper.

Sliding Pin, Sliding Pin Bolt, and Sliding Pin Boot

Check sliding pins, sliding pin bolts and sliding pin boots for wear, damage, and cracks. Replace affected parts as necessary.

ASSEMBLY

1. Apply rubber grease to new piston seal and install into cylinder body.

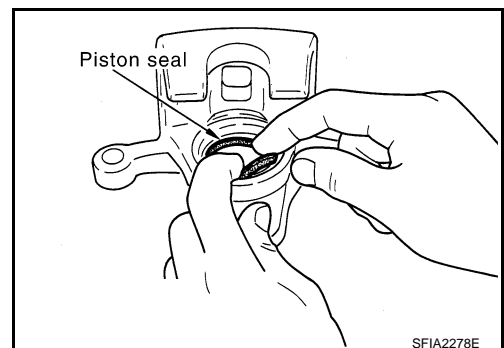

FRONT DISC BRAKE

< SERVICE INFORMATION >

2. Apply rubber grease to new piston boot and apply brake fluid to piston. Cover the piston end with piston boot, and install cylinder-side lip on piston boot properly into groove on cylinder body using a suitable tool.

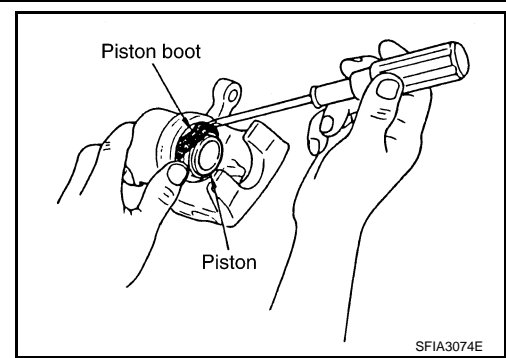

3. Press piston into cylinder body by hand to assemble piston-side lip on piston boot properly into a groove on piston.

CAUTION:

Press piston evenly and change pressing point to prevent inner wall of cylinder from being rubbed.

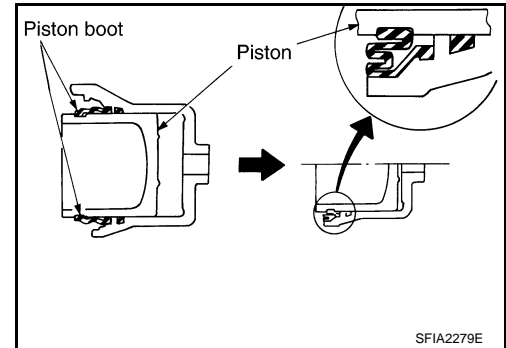

4. Install the cylinder body on the torque member. Refer to [BR-27, "Removal and Installation of Brake Caliper Assembly"](#).

DISC ROTOR INSPECTION

Visual Inspection

Check surfaces of disc rotor for uneven wear, cracks or serious damage. Replace as necessary.

Runout Inspection

1. Secure disc rotor to wheel hub at two or more positions using wheel nuts.
2. Inspect runout using a dial gauge located at a point 10 mm (0.39 in) from the edge.

CAUTION:

Make sure that wheel bearing axial end play is within the specifications before measuring runout. Refer to [FAX-6, "On-Vehicle Inspection and Service"](#).

Runout limit : Refer to [BR-47, "Front Disc Brake"](#).

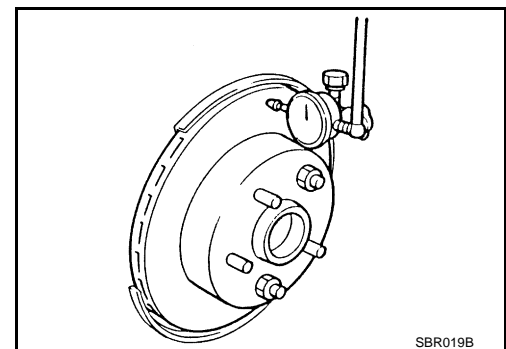

3. If runout is outside the limit, find the minimum runout point by shifting the mounting positions of disc rotor and wheel hub by one hole.
4. If runout is still out of specification, turn the disc rotor using Tool until runout is with the specified limit.

Tool number : 38-PFM90.5 (—)

Thickness Inspection

FRONT DISC BRAKE

< SERVICE INFORMATION >

Using a micrometer, check thickness of disc rotor. If thickness is outside the specification, replace disc rotor.

Repair limit thickness : Refer to [BR-47. "Front Disc Brake"](#).

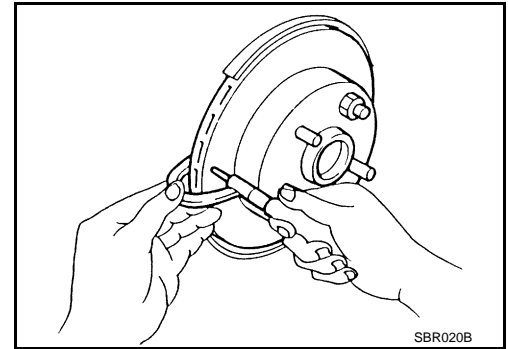

Brake Burnishing

INFOID:000000004406708

Burnish the new braking surfaces according to following procedure after refinishing or replacing disc rotors, pads, or if a soft pedal occurs at very low mileage.

CAUTION:

- **Be careful of vehicle speed because brake does not operate easily until pad and disc rotor are securely fitted.**
 - **Only perform this procedure under safe road and traffic conditions. Use extreme caution.**
1. Drive vehicle on straight, flat road.
 2. Depress brake pedal with the power to stop vehicle within 3 to 5 seconds until the vehicle stops.
 3. Drive without depressing brake pedal for a few minutes to cool brake.
 4. Repeat steps 1 to 3 until pad and disc rotor are securely fitted.

REAR DISC BRAKE

< SERVICE INFORMATION >

REAR DISC BRAKE

On Board Inspection

INFOID:000000004406709

PAD WEAR INSPECTION

Inspect pad thickness from check hole in cylinder body. Refer to [BR-48, "Rear Disc Brake"](#).

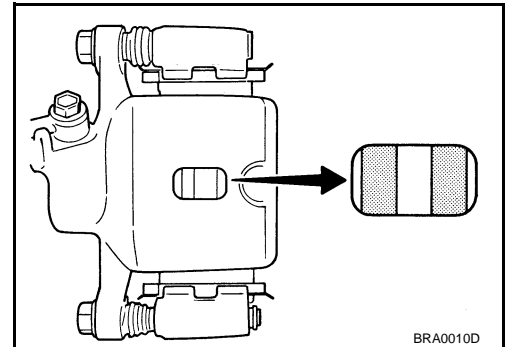

Component

INFOID:000000004406710

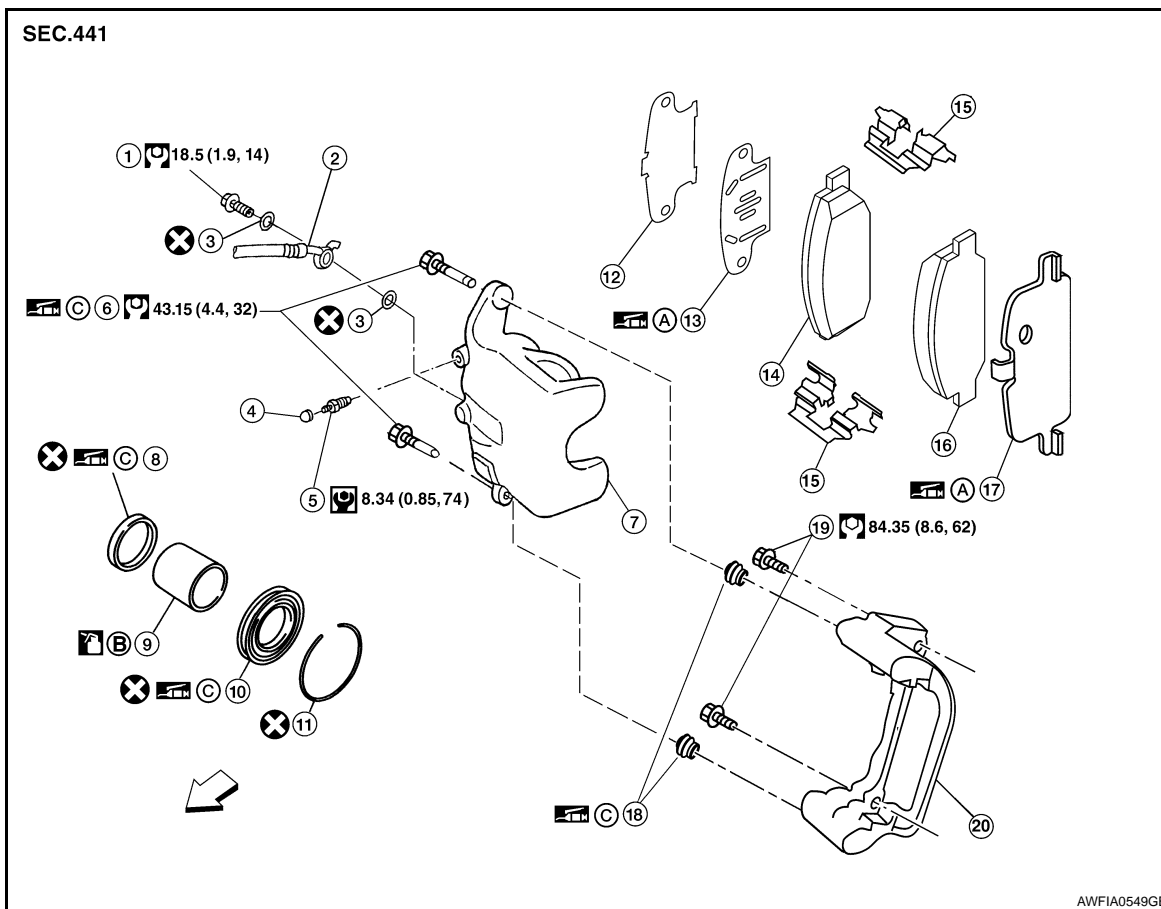

- | | | |
|-------------------------|-------------------------------|----------------------|
| 1. Union bolt | 2. Brake hose | 3. Copper washer |
| 4. Cap | 5. Air bleeder | 6. Sliding pin |
| 7. Cylinder body | 8. Piston seal | 9. Piston |
| 10. Piston boot | 11. Retaining ring | 12. Inner shim cover |
| 13. Inner shim | 14. Inner pad | 15. Pad retainer |
| 16. Outer pad | 17. Outer cover (multi-layer) | 18. Sliding pin boot |
| 19. Torque member bolts | 20. Torque member | ← Front |
| A. Molykote M-77 grease | B. Brake fluid | C. Rubber grease |

REAR DISC BRAKE

< SERVICE INFORMATION >

CAUTION:

- Clean dust with a vacuum dust collector. Do not blow with compressed air.
- Make sure parking brake lever is released completely.

Removal and Installation of Brake Pad

INFOID:000000004406711

WARNING:

Clean dust on caliper and brake pad with a vacuum dust collector to minimize the hazard of air borne particles or other materials.

CAUTION:

- While removing caliper, do not depress brake pedal because piston will pop out.
- It is not necessary to remove bolts on torque member and brake hose except for disassembly or replacement of caliper assembly. In this case, hang caliper with a wire so as not to stretch brake hose.
- Do not damage piston boot.
- If any shim is subject to serious corrosion, replace it with a new one.
- Always replace shim and shim cover as a set when replacing brake pads.
- Keep rotor free from brake fluid.
- Burnish the brake pads and disc rotor mutually contacting surfaces, after refinishing or replacing rotors, after replacing pads, or if a soft pedal occurs at very low mileage. Refer to [BR-40. "Brake Burnishing"](#).

REMOVAL

1. Drain a quarter of the brake fluid from the reservoir.
2. Remove rear wheels and tires using power tool.
3. Remove lower sliding pin.

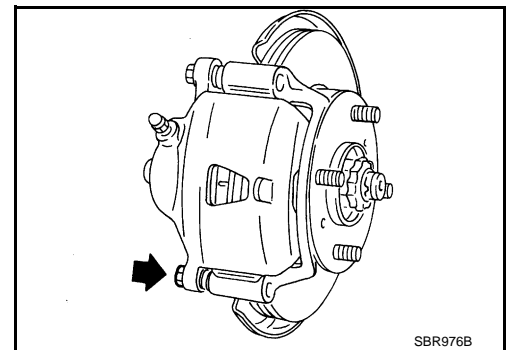

4. Swing cylinder body up and support cylinder body with a suitable wire as shown. Remove pads, shim, covers and pad retainers from torque member.

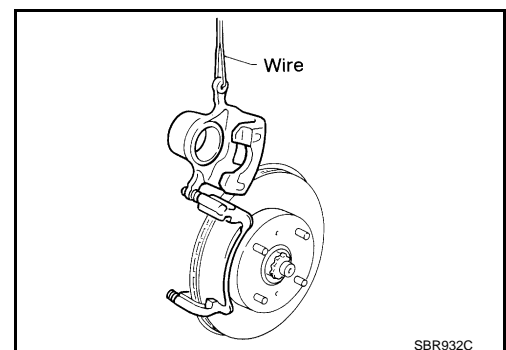

CAUTION:

REAR DISC BRAKE

< SERVICE INFORMATION >

When removing pad retainer from torque member, lift pad retainer in the direction shown by arrow, so as not to deform it.

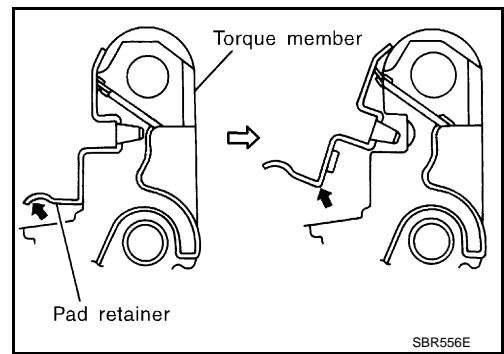

INSTALLATION

1. Apply Molykote M-77 grease between the inner shim and inner shim cover. Apply Molykote M-77 grease inside the outer cover.
2. Attach the inner shim and inner shim cover to the inner pad, and the outer cover to the outer pad.
3. Install the pad retainers and assembled pads on the torque member.

CAUTION:

- When installing pad retainer, attach it firmly so that it is not lifted up from torque member, as shown.

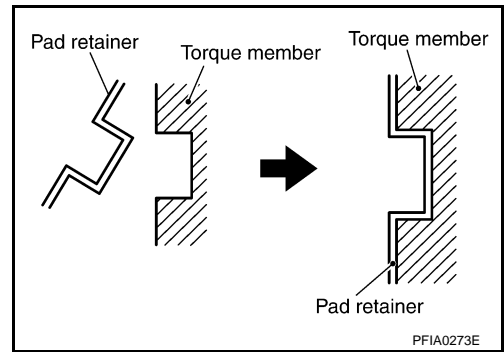

4. Install the cylinder body to the torque member.
 - Press the piston into the cylinder body using a suitable tool.

CAUTION:

Check the brake fluid level in the reservoir tank because brake fluid returns to master cylinder reservoir tank when pressing piston in.

5. Install the lower sliding pin and tighten to the specified torque. Refer to [BR-33, "Component"](#).

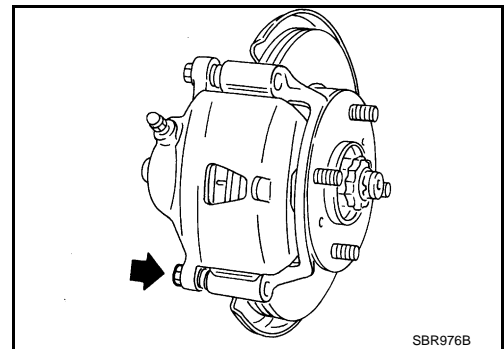

6. Check rear brakes for drag.
7. Install rear wheels and tires. Refer to [WT-8, "Rotation"](#).

Removal and Installation of Caliper Assembly

INFOID:000000004406712

WARNING:

Clean dust on caliper and brake pad with a vacuum dust collector to minimize the hazard of air borne particles or other materials.

CAUTION:

- While removing caliper, do not depress brake pedal because piston will pop out.

REAR DISC BRAKE

< SERVICE INFORMATION >

- It is not necessary to remove bolts on torque member and brake hose except for disassembly or replacement of caliper assembly. In this case, hang caliper with a wire so as not to stretch brake hose.
- Do not damage piston boot.
- If any shim is subject to serious corrosion, replace it with a new one.
- Always replace shim and shim cover as a set when replacing brake pads.
- Keep rotor free from brake fluid.
- Burnish the brake pads and disc rotor mutually contacting surfaces, after refinishing or replacing rotors, after replacing pads, or if a soft pedal occurs at very low mileage. Refer to [WT-8. "Rotation"](#).

REMOVAL

1. Drain a quarter of the brake fluid from the reservoir.
2. Remove rear wheels and tires using power tool.
3. Secure disc rotor using wheel nuts.
4. Remove the union bolt to disconnect the rear brake hose. Discard the copper washers.

CAUTION:

Do not reuse the copper washers.

5. Remove sliding pins (A) and remove cylinder body from torque member.

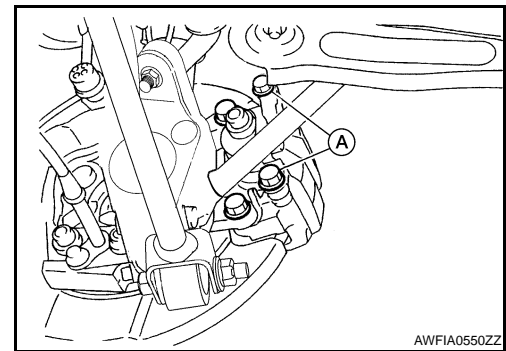

6. If necessary, remove torque member and disc rotor. If the disc rotor cannot be removed, remove as follows:

- Make sure parking brake lever is completely disengaged.
- Hold down the disc rotor with the wheel nut and remove the adjuster hole plug.
- Insert a flat-bladed screwdriver through the plug opening and rotate the star wheel on the adjuster assembly in the direction shown to loosen and retract the brake shoes.
- Prior to removing disc rotor, make alignment mark using a marker between the hub and disc rotor.
- Remove wheel nut and rotor.

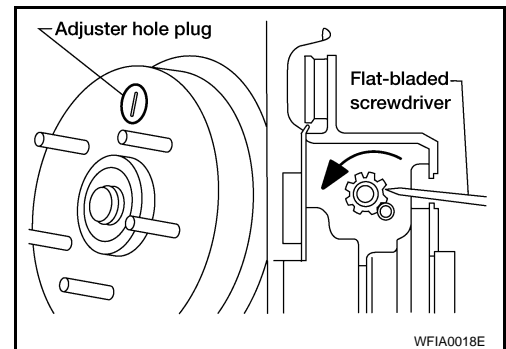

INSTALLATION

1. If necessary, install disc rotor and torque member.
 - Align marks made during removal on the hub and disc rotor.
2. Install cylinder body to the torque member and tighten sliding pins (A) to the specified torque. Refer to [BR-33. "Component"](#).

CAUTION:

Before installing cylinder body, wipe off oil and grease on mounting surfaces of cylinder body.

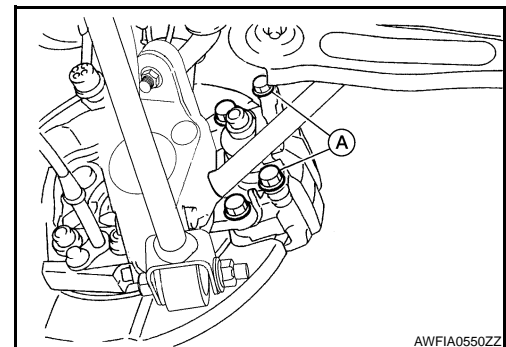

REAR DISC BRAKE

< SERVICE INFORMATION >

3. Install brake hose with new copper washers to cylinder body and tighten union bolt to the specified torque. Refer to [BR-33, "Component"](#).
CAUTION:
 - Do not reuse the copper washers.
 - Align brake hose protrusion to groove on cylinder body.
4. Adjust the parking brake. Refer to [PB-4, "On-Vehicle Service"](#).
5. Bleed the brake system. Refer to [BR-9, "Bleeding Brake System"](#).
6. Install rear wheels and tires. Refer to [WT-8, "Rotation"](#).

Disassembly and Assembly of Caliper Assembly

INFOID:000000004406713

WARNING:

Clean dust on caliper and brake pad with a vacuum dust collector to minimize the hazard of air borne particles or other materials.

CAUTION:

- While removing caliper, do not depress brake pedal because piston will pop out.
- It is not necessary to remove bolts on torque member and brake hose except for disassembly or replacement of caliper assembly. In this case, hang caliper with a wire so as not to stretch brake hose.
- Do not damage piston boot.
- If any shim is subject to serious corrosion, replace it with a new one.
- Always replace shim and shim cover as a set when replacing brake pads.
- Keep rotor free from brake fluid.
- Burnish the brake pads and disc rotor mutually contacting surfaces, after refinishing or replacing rotors, after replacing pads, or if a soft pedal occurs at very low mileage. Refer to [BR-40, "Brake Burnishing"](#).

NOTE:

Do not remove torque member, brake pads, shims and pad retainers, when disassembling or assembling cylinder body.

DISASSEMBLY

1. Remove the cylinder body from the torque member. Refer to [BR-35, "Removal and Installation of Caliper Assembly"](#).
2. Remove sliding pin boot from the torque member.
3. Remove the retaining ring from the cylinder body using a suitable tool as shown. Discard the retaining ring.

CAUTION:

Do not reuse the retaining ring.

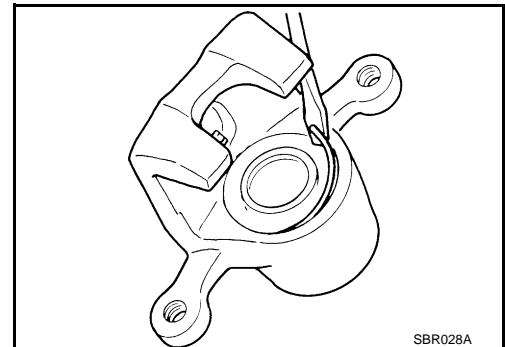

4. Place a wooden block as shown, and blow air from union bolt hole to remove piston and piston boot.

WARNING:

Do not place your finger in front of piston.

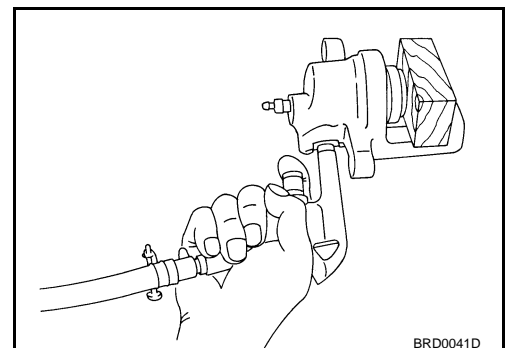

REAR DISC BRAKE

< SERVICE INFORMATION >

5. Remove piston seal from cylinder body using a suitable tool as shown.

CAUTION:

Be careful not to damage cylinder inner wall.

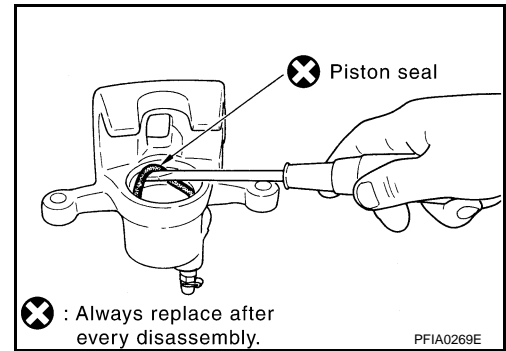

INSPECTION AFTER DISASSEMBLY

Cylinder Body

Check the inner wall of cylinder for corrosion, wear, and damage. Replace cylinder body as necessary.

CAUTION:

Clean cylinder body using new brake fluid. Never use mineral oils such as gasoline or kerosene.

Torque Member

Check for wear, cracks, and damage. Replace torque member as necessary.

Piston

Check piston surface for corrosion, wear, and damage. Replace piston as necessary.

CAUTION:

The piston sliding surface is plated. Do not polish with sandpaper.

Sliding Pin and Sliding Pin Boot

Check sliding pins and sliding pin boots for wear, damage, and cracks. Replace affected parts as necessary.

ASSEMBLY

1. Apply a rubber grease to the new piston seal and install into the cylinder body.

CAUTION:

Do not reuse the piston seals.

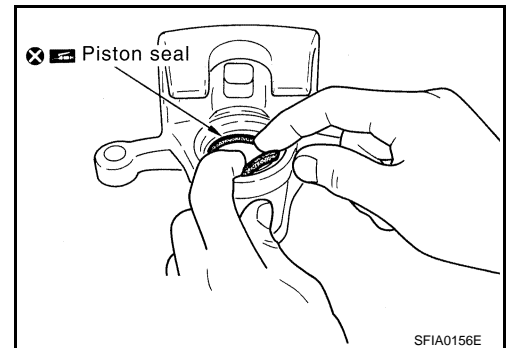

2. Apply rubber grease to the new piston boot and install on the piston, then firmly insert the new piston boot cylinder-side lip into the cylinder body groove.

CAUTION:

Do not reuse the piston boot.

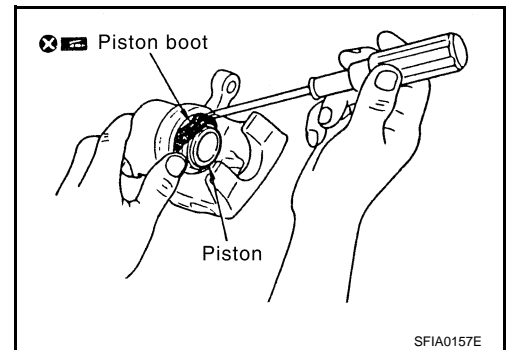

REAR DISC BRAKE

< SERVICE INFORMATION >

3. Apply a brake fluid to the piston then insert it into the cylinder body by hand and firmly attach the new piston boot piston-side lip into the new piston boot.

CAUTION:

Press the piston evenly and vary the pressing point to prevent cylinder inner wall from being rubbed.

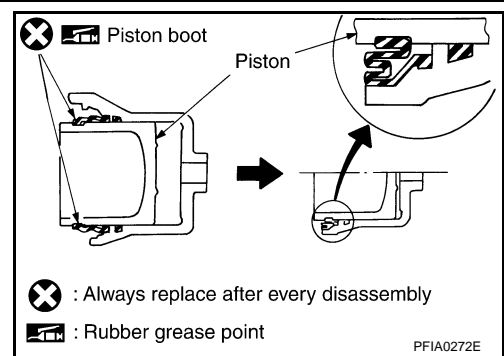

4. Install the new retaining ring to hold the piston boot.

CAUTION:

- Make sure the boot is firmly in the cylinder body groove.
- Do not reuse the retaining ring.

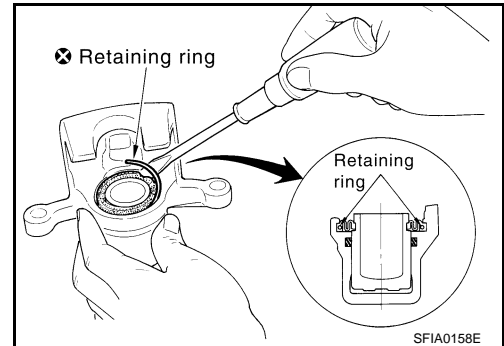

5. Attach the sliding pin boot to the torque member.
6. Install the cylinder body on the torque member. Refer to [BR-35, "Removal and Installation of Caliper Assembly"](#).

DISC ROTOR INSPECTION

Visual Inspection

Check surface of the disc rotor for uneven wear, cracks or serious damage. Replace as necessary.

Runout Inspection

1. Secure disc rotor to the wheel hub in two or more positions, using wheel nuts.
2. Inspect runout using a dial gauge located at a point 10 mm (0.39 in) from the edge.

CAUTION:

Before measuring, make sure the axle end play is with specification. Refer to [RAX-6, "On-Vehicle Inspection and Service"](#).

Runout limit : Refer to [BR-48, "Rear Disc Brake"](#).

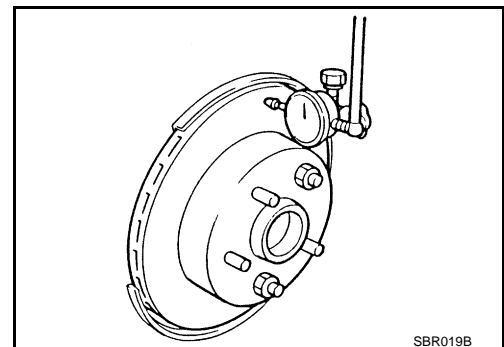

3. If runout is outside the limit, find the minimum runout point by shifting mounting positions of the disc rotor and wheel hub by one hole.
4. If runout is still out of specification, turn the disc rotor using Tool until runout is with the specified limit.

Tool number : 38-PFM90.5 (—)

Thickness Inspection

REAR DISC BRAKE

< SERVICE INFORMATION >

Using a micrometer, check thickness of the disc rotor. If thickness is not within specification, replace disc rotor.

Repair limit thickness : Refer to [BR-48. "Rear Disc Brake"](#).

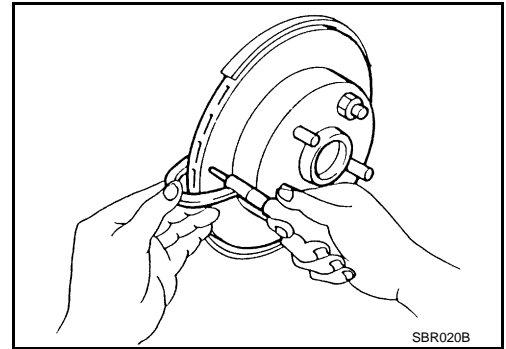

Brake Burnishing

INFOID:000000004406714

Burnish the new braking surfaces according to following procedure after refinishing or replacing disc rotors, pads, or if a soft pedal occurs at very low mileage.

CAUTION:

- **Be careful of vehicle speed because brake does not operate easily until pad and disc rotor are securely fitted.**
 - **Only perform this procedure under safe road and traffic conditions. Use extreme caution.**
1. Drive vehicle on straight, flat road.
 2. Depress brake pedal with the power to stop vehicle within 3 to 5 seconds until the vehicle stops.
 3. Drive without depressing brake pedal for a few minutes to cool brake.
 4. Repeat steps 1 to 3 until pad and disc rotor are securely fitted.

REAR DRUM BRAKE

< SERVICE INFORMATION >

REAR DRUM BRAKE

Component

INFOID:000000004406715

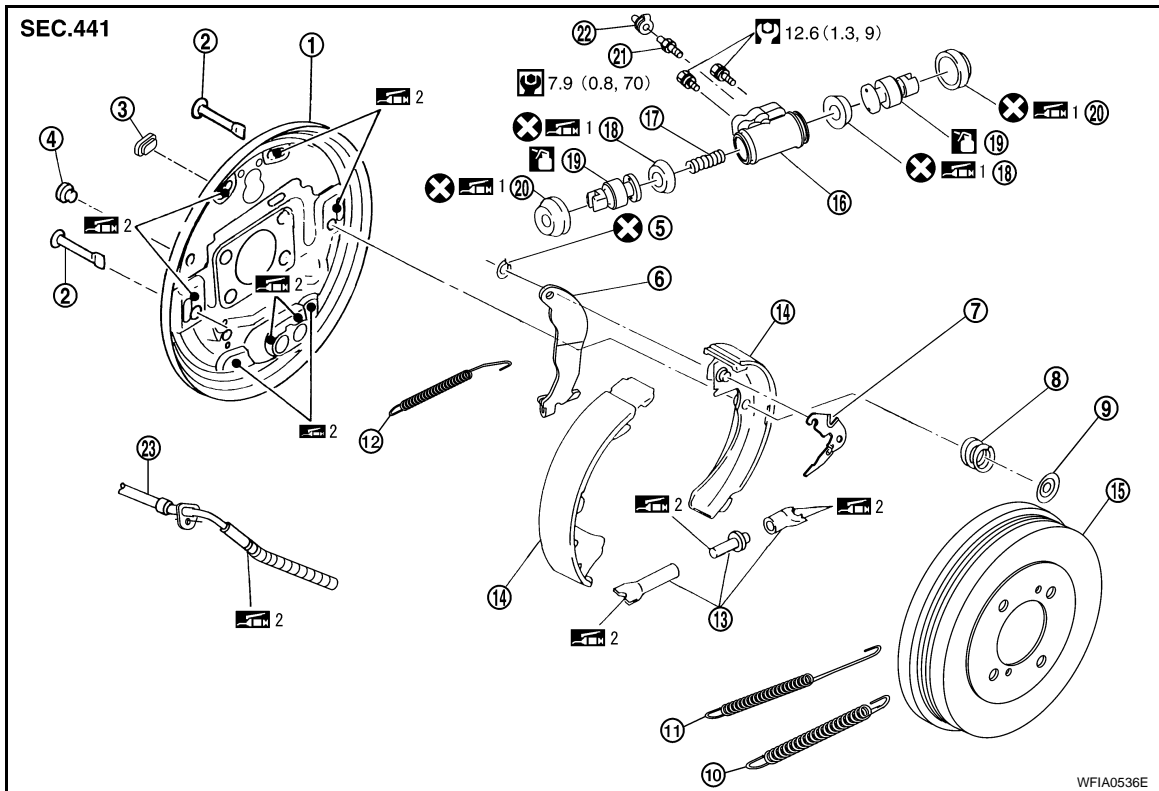

- | | | |
|--------------------------------|--------------------------------|---------------------|
| 1. Back plate | 2. Shoe hold pin | 3. Plug |
| 4. Plug | 5. Retainer ring | 6. Operating lever |
| 7. Adjuster lever | 8. Spring | 9. Retainer |
| 10. Return spring (lower side) | 11. Return spring (upper side) | 12. Adjuster spring |
| 13. Adjuster | 14. Brake shoe | 15. Brake drum |
| 16. Wheel cylinder | 17. Spring | 18. Piston cup |
| 19. Piston | 20. Boot | 21. Bleed valve |
| 22. Cap | 23. Parking brake rear cable | |
- 1: NISSAN rubber lubricant (KRE12 00030)
 2: NISSAN brake grease (KRF00 00005)
 : Brake fluid

CAUTION:

- Clean dust on drum and back plate with a vacuum dust collector. Do not blow with compressed air.
- Make sure parking brake lever is released completely.

Removal and Installation of Drum Brake Assembly

INFOID:000000004406716

WARNING:

Clean dust with a vacuum dust collector to minimize the hazard of air borne particles or other materials.

CAUTION:

- While removing brake shoes, do not depress brake pedal because wheel cylinder pistons will pop out.
- It is not necessary to disconnect brake tube except for disassembly or replacement of wheel cylinder assembly.
- Keep drum free from brake fluid.

REMOVAL

REAR DRUM BRAKE

< SERVICE INFORMATION >

1. Remove rear wheels and tires using power tools.
2. With the parking brake lever released, remove the brake drum. If it is difficult to remove the brake drum, use the following procedure.
 - a. Remove the plug from the back plate.
 - b. Press up adjuster lever with a suitable tool from the plug hole (at the side of wheel cylinder) on the back plate as shown. Turn the frame of the adjuster assembly using a suitable tool in the direction that narrows the expanded brake shoes.

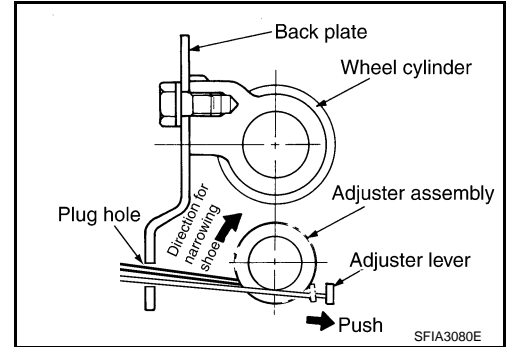

3. While pushing and rotating the retainer, pull out the shoe hold pin, and remove the brake shoe assembly.
CAUTION:
Do not damage the wheel cylinder boot.

4. Disconnect the parking brake rear cable from the operating lever.
CAUTION:
Do not bend the parking brake cable.

5. Disassemble the brake shoe assembly (brake shoes, springs, adjuster and adjuster lever).

6. Remove the retainer ring (A) with a suitable tool to separate the operating lever (C) from brake shoe.

- Contact point (B)
- Pin (D)

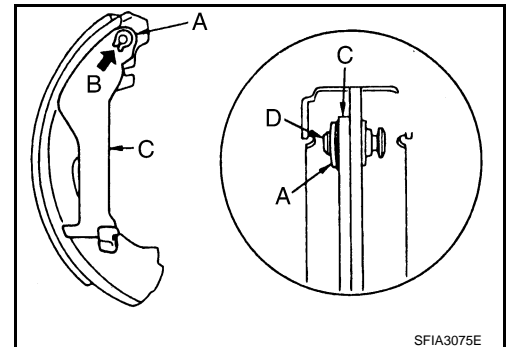

INSPECTION AFTER REMOVAL

Lining Thickness Inspection

Check lining thickness.

Standard thickness (A) : Refer to [BR-48, "Rear Drum Brake"](#).

Repair limit thickness (A) : Refer to [BR-48, "Rear Drum Brake"](#).

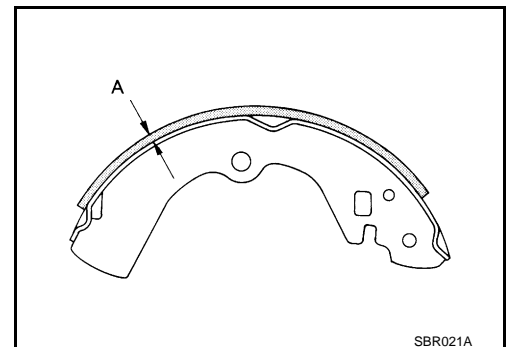

Drum Inner Diameter Inspection

REAR DRUM BRAKE

< SERVICE INFORMATION >

Check inner diameter of brake drum.

Measurement area: lining contact surface (center)

Standard inner diameter : Refer to [BR-48, "Rear Drum Brake"](#).

Repair limit inner diameter : Refer to [BR-48, "Rear Drum Brake"](#).

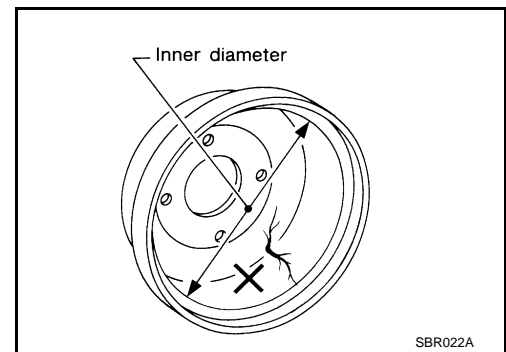

Wheel Cylinder Leakage Inspection

- Check wheel cylinder for brake fluid leakage.
- Check for wear, damage, and looseness. If any non-standard condition is found, replace it.

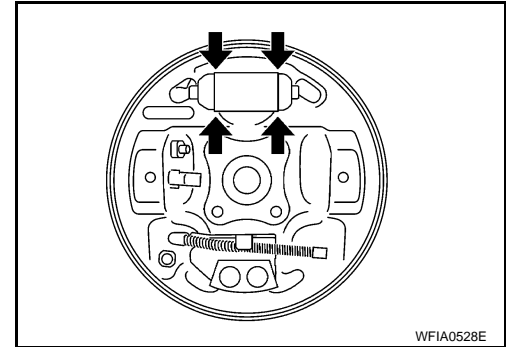

Other Inspections

Check the following:

- Inside of the drum for excessive wear, damage, and cracks.
- Lining for excessive wear, damage, and peeling.
- Shoe sliding surface for excessive wear and damage.
- Return spring for sagging.
- Check back plate for damage, cracks, and deformation. Replace back plate as necessary.

Replace applicable part as necessary.

INSTALLATION

1. Install the operating lever (C) using the following procedure.
 - a. Position operating lever (C) on brake shoe.
 - b. Install retainer ring (A) on operating lever (C), and crimp them until their contact points (B) are met.
 - Pin (D)

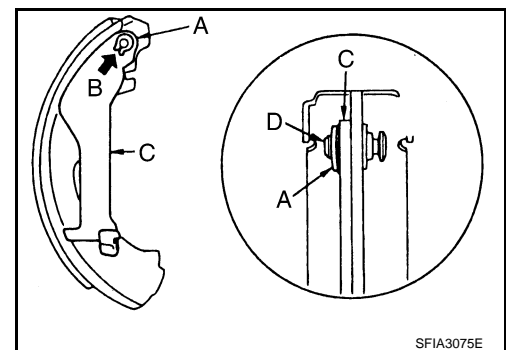

2. Apply NISSAN brake grease (KRF00 00005) to brake shoes sliding surfaces (the shaded areas) and other parts on the back plate as indicated by arrows.

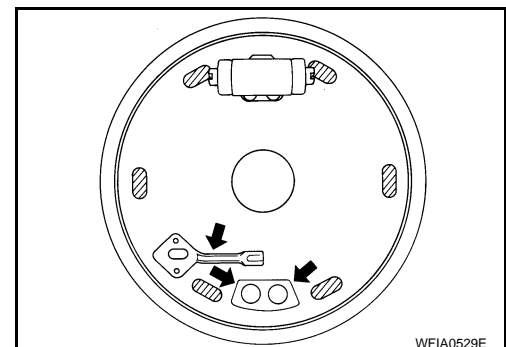

A
B
C
D
E
BR
G
H
I
J
K
L
M
N
O
P

REAR DRUM BRAKE

< SERVICE INFORMATION >

3. Apply NISSAN brake grease (KRF00 00005) to screw and confirm the difference between right and left wheel for assembling when disassembled.

Right rear wheel **Thread cutting** : **Right-hand screw direction**
Left rear wheel **Thread cutting** : **Left-hand screw direction**

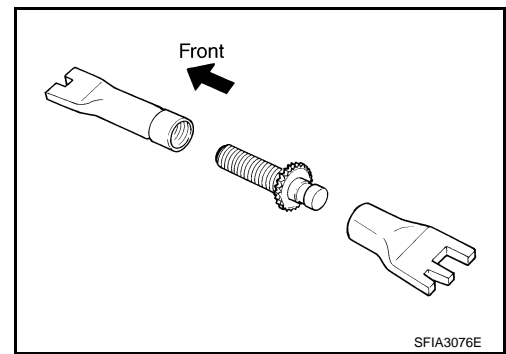

4. Assemble the shoe, adjuster, adjuster lever and springs on the shoe assembly.
5. Connect the parking brake rear cable to the operating lever.
6. Install the shoe assembly. After installation be sure that each part is installed properly.
CAUTION:
Do not damage the wheel cylinder piston boot.
7. Install the brake drum.
8. Depress brake pedal approximately 2 to 3 times.
9. Adjust the clearance of brake shoe.
10. Install rear wheels and tires. Refer to [WT-8. "Rotation"](#).

Removal and Installation of Wheel Cylinder

INFOID:000000004406717

WARNING:

Clean dust with a vacuum dust collector to minimize the hazard of air borne particles or other materials.

CAUTION:

- While removing brake shoes, do not depress brake pedal because wheel cylinder pistons will pop out.
- It is not necessary to disconnect brake tube except for disassembly or replacement of wheel cylinder assembly.
- Keep drum free from brake fluid.

REMOVAL

1. Remove the rear drum brake assembly. Refer to [BR-41. "Removal and Installation of Drum Brake Assembly"](#).
2. Disconnect the brake tube from the wheel cylinder.
3. Remove the wheel cylinder bolts, and then remove wheel cylinder from the back plate.

INSTALLATION

Installation is in the reverse order of removal.

- Tighten bolts to the specified torque. Refer to [BR-41. "Component"](#).
- Bleed the brake system. Refer to [BR-9. "Bleeding Brake System"](#).

Disassembly and Assembly of Wheel Cylinder

INFOID:000000004406718

WARNING:

Clean dust with a vacuum dust collector to minimize the hazard of air borne particles or other materials.

CAUTION:

- While removing brake shoes, do not depress brake pedal because wheel cylinder pistons will pop out.
- It is not necessary to disconnect brake tube except for disassembly or replacement of wheel cylinder assembly.
- Keep drum free from brake fluid.

DISASSEMBLY

1. Remove the wheel cylinder. Refer to [BR-44. "Removal and Installation of Wheel Cylinder"](#).

REAR DRUM BRAKE

< SERVICE INFORMATION >

2. Remove the boots from the ends of the wheel cylinder and discard the boots.

CAUTION:

Do not reuse the boots.

3. Pull out the pistons from the wheel cylinder.
4. Remove piston cups from the piston and discard the piston cups.

CAUTION:

Do not reuse the piston cups.

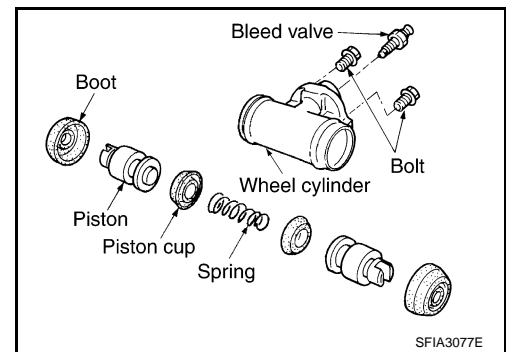

5. Remove the bleed valve and cap.

INSPECTION AFTER DISASSEMBLY

Check the pistons, spring, and inner wall of the cylinder for wear, corrosion, and damage. If malfunction is detected, replace it.

ASSEMBLY

CAUTION:

Do not use NISSAN rubber grease (KRE00 00010, KRE00 00011) during assembly.

1. Install the bleed valve and cap, tighten to specification. Refer to [BR-41. "Component"](#).
2. Apply brake fluid to the piston sliding surface on the wheel cylinder.
3. Apply NISSAN rubber lubricant (KRE12 00030) to the piston cups and boots. Assemble the spring, piston cups, and piston inside the wheel cylinder as shown.

CAUTION:

When inserting the piston, be careful not to scratch the wheel cylinder wall.

4. Install the boots on the wheel cylinder securing them in the grooves as shown.

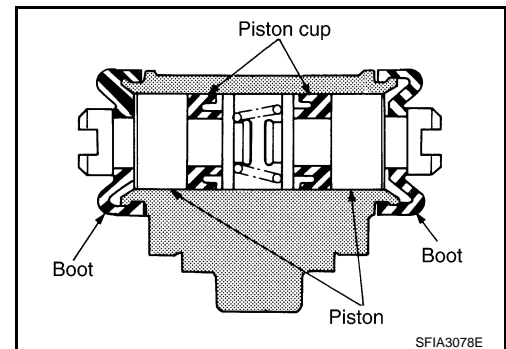

5. Install the wheel cylinder. Refer to [BR-44. "Removal and Installation of Wheel Cylinder"](#).

SERVICE DATA AND SPECIFICATIONS (SDS)

< SERVICE INFORMATION >

SERVICE DATA AND SPECIFICATIONS (SDS)

General Specification

INFOID:000000004406719

Unit: mm (in)

Applied model		MR20DE	QR25DE	
		Base, S, SL	SE-R	SE-R SPEC-V
Front disc brake	Brake model	CLZ25VB	CLZ25VJ	AD25V
	Cylinder bore diameter	57.2 (2.252)	57.2 (2.252)	57.15 (2.250)
	Pad thickness	11 (0.433)	11 (0.433)	11 (0.433)
	Rotor outer diameter × thickness	280 × 24.0 (11.02 × 0.945)	296 × 26.0 (11.65 × 1.024)	320 × 28.0 (12.60 × 1.102)
Rear disc brake	Brake model	—	AD9A/DS17	
	Cylinder bore diameter	—	34.93 (1.375)	
	Pad thickness	—	8.5 (0.335)	
	Rotor outer diameter × thickness	—	292 × 9.0 (11.50 × 0.354)	
Rear drum brake	Brake model	LT23E	—	—
	Cylinder bore diameter	19.05 (0.750)	—	—
	Lining Length × width × thickness	194.1 × 35 × 2.9 (7.642 × 1.378 × 0.114)	—	—
	Drum inner diameter	228.6 (9.000)	—	—
Master cylinder	Cylinder bore diameter	23.81 (0.937)		
Brake booster	Booster model	C255		
	Diaphragm diameter	255 (10.04)		
Recommended brake fluid		DOT 3		

Brake Pedal

INFOID:000000004406720

Unit: mm (in)

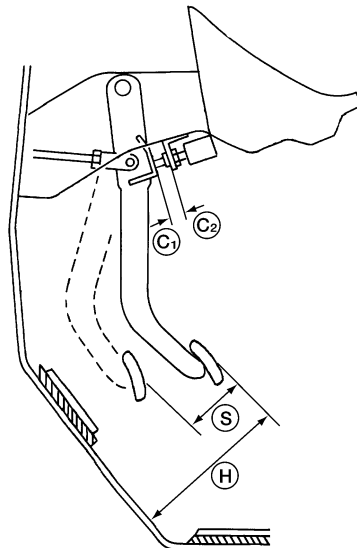

AWFIA0433ZZ

SERVICE DATA AND SPECIFICATIONS (SDS)

< SERVICE INFORMATION >

Brake pedal height (H) (from dash lower panel top surface)	CVT	164.0 - 174.0 (6.46 - 6.85)
	M/T	164.0 - 174.0 (6.46 - 6.85)
Brake pedal full stroke (S) [under a force of 490 N (50 kg-f, 110 lb-f) with engine running]	CVT	135.1 (5.32)
	M/T	135.1 (5.32)
Clearance between stopper bracket and threaded end of the stop lamp switch and ASCD cancel switch (C1 and C2)		0.74 - 1.96 (0.0291 - 0.0772)

Check Valve

INFOID:000000004406721

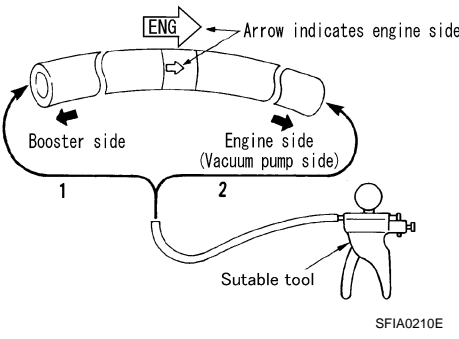
	
Vacuum leakage when connected to booster side (1) [at vacuum of - 66.7 kPa (- 500 mmHg, - 19.69 inHg)]	Within 1.3 kPa (10 mmHg, 0.39 inHg) of vacuum for 15 seconds
Vacuum leakage when connected to engine side (2)	No vacuum will be applied.

Brake Booster

INFOID:000000004406723

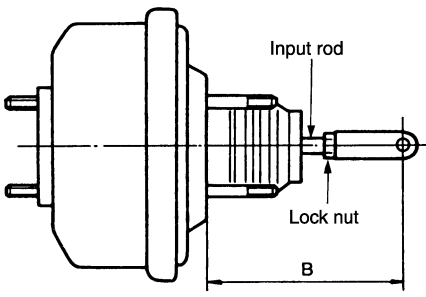
	
Input rod installation standard length (B)	163.2 - 164.2 mm (6.43 - 6.46 in)
Vacuum leakage [at vacuum of - 66.7 kPa (- 500 mmHg, -19.69 inHg)]	Within 1.3 kPa (10 mmHg, 0.39 inHg) of vacuum for 15 seconds

Dual Proportioning Valve

INFOID:000000004406723

Unit: kPa (kg/cm ² , psi)	
Applied pressure (Front brake)	7,355 (75, 1,067)
Output pressure (Rear brake)	5,099 - 5,492 (52 - 56, 740 - 796)

Front Disc Brake

INFOID:000000004406724

CLZ25VB

SERVICE DATA AND SPECIFICATIONS (SDS)

< SERVICE INFORMATION >

Unit: mm (in)

Brake pad	Standard thickness (new)	11 (0.433)
	Repair limit thickness	2.0 (0.079)
Disc rotor	Standard thickness (new)	24.0 (0.945)
	Repair limit thickness	22.0 (0.866)
	Runout limit	0.035 (0.0014)
	Maximum uneven wear (measured at 8 positions)	0.02 mm (0.0008 in) or less

CLZ25VJ

Unit: mm (in)

Brake pad	Standard thickness (new)	11 (0.433)
	Repair limit thickness	2.0 (0.079)
Disc rotor	Standard thickness (new)	26.0 (1.024)
	Repair limit thickness	24.0 (0.945)
	Runout limit	0.035 (0.0014)
	Maximum uneven wear (measured at 8 positions)	0.02 mm (0.0008 in) or less

AD25V

Unit: mm (in)

Brake pad	Standard thickness (new)	11 (0.433)
	Repair limit thickness	2.0 (0.079)
Disc rotor	Standard thickness (new)	28.0 (1.102)
	Repair limit thickness	26.0 (1.024)
	Runout limit	0.035 (0.0014)
	Maximum uneven wear (measured at 8 positions)	0.02 mm (0.0008 in) or less

Rear Disc Brake

INFOID:000000004406725

DA9A/DS17

Unit: mm (in)

Brake pad	Standard thickness (new)	8.5 (0.335)
	Repair limit thickness	2.0 (0.079)
Disc rotor	Standard thickness (new)	9.0 (0.354)
	Repair limit thickness	8.0 (0.315)
	Runout limit	0.07 (0.0028)
	Maximum uneven wear (measured at 8 positions)	0.015 mm (0.0006 in) or less

Rear Drum Brake

INFOID:000000004406726

LT23E

Unit: mm (in)

Brake lining	Standard thickness (new)	2.9 (0.114)
	Repair limit thickness	1.5 (0.059)
Drum	Standard inner diameter (new)	228.6 (9.000)
	Repair limit inner diameter	230.0 (9.055)