

# BL

## SECTION

# BODY, LOCK & SECURITY SYSTEM

A  
B  
C  
D  
E  
F  
G  
H  
I  
J  
K  
L  
M  
N  
O  
P

### CONTENTS

<p><b>SERVICE INFORMATION</b> ..... 4</p> <p><b>PRECAUTIONS</b> ..... 4</p> <p style="padding-left: 20px;">Precaution for Supplemental Restraint System (SRS) "AIR BAG" and "SEAT BELT PRE-TENSIONER" .....4</p> <p style="padding-left: 20px;">Precaution Necessary for Steering Wheel Rotation After Battery Disconnect .....4</p> <p style="padding-left: 20px;">Precaution for Procedure without Cowl Top Cover.....5</p> <p style="padding-left: 20px;">Precaution for Work .....5</p> <p><b>PREPARATION</b> ..... 6</p> <p style="padding-left: 20px;">Special Service Tool .....6</p> <p style="padding-left: 20px;">Commercial Service Tool .....6</p> <p><b>SQUEAK AND RATTLE TROUBLE DIAGNOSIS</b> ..... 7</p> <p style="padding-left: 20px;">Work Flow .....7</p> <p style="padding-left: 20px;">Generic Squeak and Rattle Troubleshooting .....9</p> <p style="padding-left: 20px;">Diagnostic Worksheet ..... 11</p> <p><b>HOOD</b> .....13</p> <p style="padding-left: 20px;">Fitting Adjustment .....13</p> <p style="padding-left: 20px;">Removal and Installation ..... 14</p> <p><b>RADIATOR CORE SUPPORT</b> .....18</p> <p style="padding-left: 20px;">Removal and Installation ..... 18</p> <p><b>FRONT FENDER</b> .....19</p> <p style="padding-left: 20px;">Removal and Installation ..... 19</p> <p><b>POWER DOOR LOCK SYSTEM</b> .....20</p> <p style="padding-left: 20px;">Component Parts and Harness Connector Location .....20</p> <p style="padding-left: 20px;">System Description .....20</p> <p style="padding-left: 20px;">CAN Communication System Description .....23</p> <p style="padding-left: 20px;">Schematic (Without Intelligent Key) .....24</p> <p style="padding-left: 20px;">Wiring Diagram - D/LOCK - (Without Intelligent Key) .....25</p> <p style="padding-left: 20px;">Schematic (With Intelligent Key) .....30</p> <p style="padding-left: 20px;">Wiring Diagram - D/LOCK - (With Intelligent Key)...31</p> <p style="padding-left: 20px;">Terminal and Reference Value for BCM .....35</p>	<p style="padding-left: 20px;">Work Flow .....35</p> <p style="padding-left: 20px;">CONSULT-III Function (BCM) .....36</p> <p style="padding-left: 20px;">Trouble Diagnosis Symptom Chart .....37</p> <p style="padding-left: 20px;">BCM Power Supply and Ground Circuit Inspection .....37</p> <p style="padding-left: 20px;">Door Switch Check .....38</p> <p style="padding-left: 20px;">Key Switch (Insert) Check .....39</p> <p style="padding-left: 20px;">Door Lock and Unlock Switch Check .....40</p> <p style="padding-left: 20px;">Front Door Lock Assembly LH (Actuator) Check ....44</p> <p style="padding-left: 20px;">Door Lock Actuator Check (Front RH and Rear LH/RH) .....45</p> <p style="padding-left: 20px;">Front Door Key Cylinder Switch LH Check .....46</p> <p style="padding-left: 20px;">Passenger Select Unlock Relay Circuit Inspection (With Intelligent Key) .....47</p> <p><b>REMOTE KEYLESS ENTRY SYSTEM</b> .....50</p> <p style="padding-left: 20px;">Component Parts and Harness Connector Location ..... 50</p> <p style="padding-left: 20px;">System Description .....50</p> <p style="padding-left: 20px;">CAN Communication System Description .....52</p> <p style="padding-left: 20px;">Schematic .....53</p> <p style="padding-left: 20px;">Wiring Diagram - KEYLES - .....54</p> <p style="padding-left: 20px;">Terminal and Reference Value for BCM .....56</p> <p style="padding-left: 20px;">How to Perform Trouble Diagnosis .....56</p> <p style="padding-left: 20px;">CONSULT-III Function (BCM) .....57</p> <p style="padding-left: 20px;">Work Flow .....58</p> <p style="padding-left: 20px;">Trouble Diagnosis Symptom Chart .....58</p> <p style="padding-left: 20px;">Keyfob Battery and Function Check .....60</p> <p style="padding-left: 20px;">ACC Switch Check .....61</p> <p style="padding-left: 20px;">Door Switch Check .....61</p> <p style="padding-left: 20px;">Key Switch Check .....63</p> <p style="padding-left: 20px;">Hazard Function Check .....64</p> <p style="padding-left: 20px;">Horn Function Check .....64</p> <p style="padding-left: 20px;">Interior Lamp Illumination Function Check .....65</p> <p style="padding-left: 20px;">Remote Keyless Entry Receiver Check .....65</p> <p style="padding-left: 20px;">Keyfob Function (Lock) Check .....67</p> <p style="padding-left: 20px;">Keyfob Function (Unlock) Check .....67</p> <p style="padding-left: 20px;">ID Code Entry Procedure .....68</p> <p style="padding-left: 20px;">Keyfob Battery Replacement .....70</p> <p style="padding-left: 20px;">Removal and Installation of Remote Keyless Entry Receiver .....70</p>
--	--

BL

<b>INTELLIGENT KEY SYSTEM</b> .....	<b>71</b>	Component Parts Location .....	135
Component Parts and Harness Connector Location .....	71	Removal and Installation .....	135
System Description .....	72	<b>REAR DOOR LOCK</b> .....	<b>138</b>
CAN Communication System Description .....	81	Component Parts Location .....	138
Schematic .....	82	Removal and Installation .....	138
Wiring Diagram - Intelligent Key - .....	84	<b>TRUNK LID</b> .....	<b>141</b>
Intelligent Key Unit Harness Connector Terminal Layout .....	92	Fitting Adjustment .....	141
Terminal and Reference Value for Intelligent Key Unit .....	92	Trunk Lid Assembly .....	141
Steering Lock Solenoid Harness Connector Terminal Layout .....	94	Trunk Lid Lock .....	142
Terminal and Reference Value for Steering Lock Solenoid .....	94	Trunk Lid Striker .....	142
Terminal and Reference Value for BCM .....	94	<b>TRUNK LID OPENER</b> .....	<b>144</b>
Terminal and Reference Value for IPDM E/R .....	94	Component Parts and Harness Connector Location .....	144
Terminal and Reference Value for Combination Meter .....	94	System Description .....	144
Trouble Diagnosis Procedure .....	94	Wiring Diagram - TLID - .....	145
CONSULT-III Function (INTELLIGENT KEY) .....	96	Terminal and Reference Value for BCM .....	146
BASIC OPERATION .....	97	Terminal and Reference Value for Intelligent Key Unit .....	146
CONSULT-III Application Item .....	97	CONSULT-III Function (BCM) .....	147
Trouble Diagnosis Symptom Chart .....	99	Work Flow .....	147
CAN Communication System Inspection .....	106	Trouble Diagnosis Chart by Symptom .....	148
Power Supply and Ground Circuit Inspection .....	106	Terminal and Reference Value for BCM .....	148
Key Switch (Intelligent Key Unit Input) Check .....	107	Terminal and Reference Value for Intelligent Key Unit .....	148
Key Switch (BCM Input) Check .....	108	BCM Power Supply and Ground Circuit Inspection .....	148
Ignition Knob Switch Check .....	109	Intelligent Key Unit Power Supply and Ground Circuit Inspection .....	148
Door Switch Check .....	110	Check Trunk Opener Request Switch Circuit (With Intelligent Key) .....	148
Trunk Room Lamp Switch Check .....	112	Check Trunk Lid Opener Actuator Circuit .....	150
Front Door Request Switch Check .....	113	<b>FUEL FILLER LID OPENER</b> .....	<b>152</b>
Trunk Opener Request Switch Check .....	115	Removal .....	152
Front Door Lock Assembly LH (Door Unlock Sensor) Check .....	117	Installation .....	152
Intelligent Key Warning Chime (Combination Meter) Check .....	118	<b>VEHICLE SECURITY (THEFT WARNING) SYSTEM</b> .....	<b>153</b>
Check Intelligent Key Warning Buzzer (Front of Vehicle) .....	118	Component Parts and Harness Connector Location .....	153
Outside Key Antenna Check .....	119	System Description .....	153
Inside Key Antenna Check .....	120	CAN Communication System Description .....	155
Steering Lock Solenoid Check .....	122	Schematic .....	156
Stop Lamp Switch Check .....	123	Wiring Diagram - VEHSEC - .....	157
CVT Device (Park Position Switch) Check .....	125	Terminal and Reference Value for BCM .....	160
"P-SHIFT" Warning Lamp Check .....	126	Terminal and Reference Value for Intelligent Key Unit .....	160
"KEY" Warning Lamp (RED) Check .....	126	CONSULT-III Function (BCM) .....	161
"KEY" Warning Lamp (GREEN) Check .....	126	Trouble Diagnosis .....	162
Hazard Function Check .....	127	Preliminary Check .....	162
Check Horn Function .....	127	Symptom Chart .....	164
IPDM E/R Operation Check .....	127	Diagnosis Procedure 1 .....	165
Intelligent Key Battery Replacement .....	128	Diagnosis Procedure 2 .....	166
Remote Keyless Entry Function .....	128	Diagnosis Procedure 3 .....	167
Removal and Installation of Intelligent Key Unit .....	129	Diagnosis Procedure 4 .....	167
Diagnosis Procedure 5 .....	167	Diagnosis Procedure 5 .....	167
Diagnosis Procedure 6 .....	167	Diagnosis Procedure 6 .....	167
<b>DOOR</b> .....	<b>130</b>		
Fitting Adjustment .....	130		
Removal and Installation .....	132		
<b>FRONT DOOR LOCK</b> .....	<b>135</b>		

Diagnosis Procedure 7 .....	168	Diagnosis Procedure 4 .....	180	
<b>NATS(Nissan Anti-Theft System) .....</b>	<b>170</b>	Diagnosis Procedure 5 .....	181	A
Component Parts and Harness Connector Location .....	170	Diagnosis Procedure 6 .....	182	
System Description .....	170	How to Replace NATS Antenna Amp .....	182	B
System Composition .....	171	<b>BODY REPAIR .....</b>	<b>183</b>	
ECM Re-communicating Function .....	171	Body Exterior Paint Color .....	183	C
Wiring Diagram - NATS - .....	172	Body Component Parts .....	184	
Terminal and Reference Value for BCM .....	172	Corrosion Protection .....	187	D
CONSULT-III Function .....	173	Body Sealing .....	190	
Trouble Diagnosis Procedure .....	173	Body Construction .....	194	E
Trouble Diagnosis .....	176	Body Alignment .....	194	
Diagnosis Procedure 1 .....	177	Handling Precaution for Plastics .....	204	F
Diagnosis Procedure 2 .....	178	Precaution in Repairing High Strength Steel .....	207	
Diagnosis Procedure 3 .....	180	Foam Repair .....	210	G
		Replacement Operation .....	212	

BL

J

K

L

M

N

O

P

# PRECAUTIONS

< SERVICE INFORMATION >

## SERVICE INFORMATION

### PRECAUTIONS

#### Precaution for Supplemental Restraint System (SRS) "AIR BAG" and "SEAT BELT PRE-TENSIONER"

INFOID:000000004407665

The Supplemental Restraint System such as "AIR BAG" and "SEAT BELT PRE-TENSIONER", used along with a front seat belt, helps to reduce the risk or severity of injury to the driver and front passenger for certain types of collision. This system includes seat belt switch inputs and dual stage front air bag modules. The SRS system uses the seat belt switches to determine the front air bag deployment, and may only deploy one front air bag, depending on the severity of a collision and whether the front occupants are belted or unbelted. Information necessary to service the system safely is included in the SRS and SB section of this Service Manual.

#### **WARNING:**

- To avoid rendering the SRS inoperative, which could increase the risk of personal injury or death in the event of a collision which would result in air bag inflation, all maintenance must be performed by an authorized NISSAN/INFINITI dealer.
- Improper maintenance, including incorrect removal and installation of the SRS, can lead to personal injury caused by unintentional activation of the system. For removal of Spiral Cable and Air Bag Module, see the SRS section.
- Do not use electrical test equipment on any circuit related to the SRS unless instructed to in this Service Manual. SRS wiring harnesses can be identified by yellow and/or orange harnesses or harness connectors.

#### Precaution Necessary for Steering Wheel Rotation After Battery Disconnect

INFOID:000000004407666

#### **NOTE:**

- This procedure is applied only to models with Intelligent Key system and NVIS/IVIS (NISSAN/INFINITI VEHICLE IMMOBILIZER SYSTEM - NATS).
- Remove and install all control units after disconnecting both battery cables with the ignition in the "LOCK" position.
- Always use CONSULT-III to perform self-diagnosis as a part of each function inspection after finishing work. If DTC is detected, perform trouble diagnosis according to self-diagnostic results.

For models equipped with the Intelligent Key system and NVIS/IVIS, an electrically controlled steering lock mechanism is adopted on the key cylinder.

For this reason, if the battery is disconnected or if the battery is discharged, the steering wheel will lock and steering wheel rotation will become impossible.

If steering wheel rotation is required when battery power is interrupted, follow the procedure below before starting the repair operation.

#### OPERATION PROCEDURE

1. Connect both battery cables.

#### **NOTE:**

Supply power using jumper cables if battery is discharged.

2. Use the Intelligent Key or mechanical key to turn the ignition switch to the "ACC" position. At this time, the steering lock will be released.
3. Disconnect both battery cables. The steering lock will remain released and the steering wheel can be rotated.
4. Perform the necessary repair operation.
5. When the repair work is completed, return the ignition switch to the "LOCK" position before connecting the battery cables. (At this time, the steering lock mechanism will engage.)
6. Perform a self-diagnosis check of all control units using CONSULT-III.



# PRECAUTIONS

< SERVICE INFORMATION >

## Precaution for Procedure without Cowl Top Cover

INFOID:000000004407667

When performing the procedure after removing cowl top cover, cover the lower end of windshield.

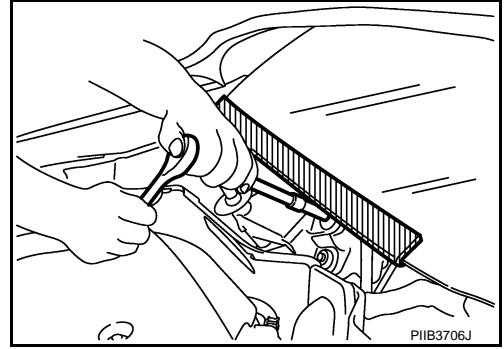

## Precaution for Work

INFOID:000000004407668

- After removing and installing the opening/closing parts, be sure to carry out fitting adjustments to check their operation.
- Check the lubrication level, damage, and wear of each part. If necessary, grease or replace it.

A  
B  
C  
D  
E  
F  
G  
H  
I  
J  
K  
L  
M  
N  
O  
P

BL

# PREPARATION

< SERVICE INFORMATION >

## PREPARATION

### Special Service Tool

INFOID:000000004407669

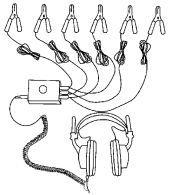
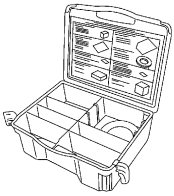
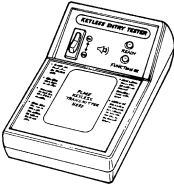
Tool number (Kent-Moore No.) Tool name	Description
<p>— (J-39570) Chassis ear</p>  <p style="text-align: right;">SIA0993E</p>	<p>Locating the noise</p>
<p>— (J-43980) NISSAN Squeak and Rattle Kit</p>  <p style="text-align: right;">SIA0994E</p>	<p>Repairing the cause of noise</p>
<p>— (J-43241) Remote Keyless Entry Tester</p>  <p style="text-align: right;">LEL946A</p>	<p>Used to test key fobs</p>

### Commercial Service Tool

INFOID:000000004407670

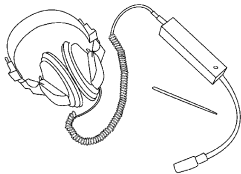
Tool name	Description
<p>Engine ear</p>  <p style="text-align: right;">SIA0995E</p>	<p>Locating the noise</p>

# SQUEAK AND RATTLE TROUBLE DIAGNOSIS

< SERVICE INFORMATION >

## SQUEAK AND RATTLE TROUBLE DIAGNOSIS

### Work Flow

INFOID:000000004407671

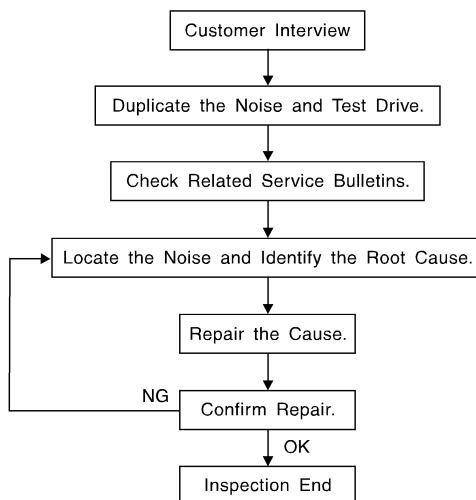

SBT842

### CUSTOMER INTERVIEW

Interview the customer if possible, to determine the conditions that exist when the noise occurs. Use the Diagnostic Worksheet during the interview to document the facts and conditions when the noise occurs and any customer's comments; refer to [BL-11, "Diagnostic Worksheet"](#). This information is necessary to duplicate the conditions that exist when the noise occurs.

- The customer may not be able to provide a detailed description or the location of the noise. Attempt to obtain all the facts and conditions that exist when the noise occurs (or does not occur).
- If there is more than one noise in the vehicle, be sure to diagnose and repair the noise that the customer is concerned about. This can be accomplished by test driving the vehicle with the customer.
- After identifying the type of noise, isolate the noise in terms of its characteristics. The noise characteristics are provided so the customer, service adviser and technician are all speaking the same language when defining the noise.
- Squeak —(Like tennis shoes on a clean floor)  
Squeak characteristics include the light contact/fast movement/brought on by road conditions/hard surfaces = higher pitch noise/softer surfaces = lower pitch noises/edge to surface = chirping.
- Creak—(Like walking on an old wooden floor)  
Creak characteristics include firm contact/slow movement/twisting with a rotational movement/pitch dependent on materials/often brought on by activity.
- Rattle—(Like shaking a baby rattle)  
Rattle characteristics include the fast repeated contact/vibration or similar movement/loose parts/missing clip or fastener/incorrect clearance.
- Knock —(Like a knock on a door)  
Knock characteristics include hollow sounding/sometimes repeating/often brought on by driver action.
- Tick—(Like a clock second hand)  
Tick characteristics include gentle contacting of light materials/loose components/can be caused by driver action or road conditions.
- Thump—(Heavy, muffled knock noise)  
Thump characteristics include softer knock/dead sound often brought on by activity.
- Buzz—(Like a bumble bee)  
Buzz characteristics include high frequency rattle/firm contact.
- Often the degree of acceptable noise level will vary depending upon the person. A noise that you may judge as acceptable may be very irritating to the customer.
- Weather conditions, especially humidity and temperature, may have a great effect on noise level.

### DUPLICATE THE NOISE AND TEST DRIVE

If possible, drive the vehicle with the customer until the noise is duplicated. Note any additional information on the Diagnostic Worksheet regarding the conditions or location of the noise. This information can be used to duplicate the same conditions when you confirm the repair.

# SQUEAK AND RATTLE TROUBLE DIAGNOSIS

## < SERVICE INFORMATION >

If the noise can be duplicated easily during the test drive, to help identify the source of the noise, try to duplicate the noise with the vehicle stopped by doing one or all of the following:

- 1) Close a door.
  - 2) Tap or push/pull around the area where the noise appears to be coming from.
  - 3) Rev the engine.
  - 4) Use a floor jack to recreate vehicle "twist".
  - 5) At idle, apply engine load (electrical load, half-clutch on M/T model, drive position on A/T model).
  - 6) Raise the vehicle on a hoist and hit a tire with a rubber hammer.
- Drive the vehicle and attempt to duplicate the conditions the customer states exist when the noise occurs.
  - If it is difficult to duplicate the noise, drive the vehicle slowly on an undulating or rough road to stress the vehicle body.

## CHECK RELATED SERVICE BULLETINS

After verifying the customer concern or symptom, check ASIST for Technical Service Bulletins (TSBs) related to that concern or symptom.

If a TSB relates to the symptom, follow the procedure to repair the noise.

## LOCATE THE NOISE AND IDENTIFY THE ROOT CAUSE

1. Narrow down the noise to a general area. To help pinpoint the source of the noise, use a listening tool (Chassis Ear: J-39570, Engine Ear: J-39565 and mechanic's stethoscope).
2. Narrow down the noise to a more specific area and identify the cause of the noise by:
  - removing the components in the area that you suspect the noise is coming from.  
Do not use too much force when removing clips and fasteners, otherwise clips and fasteners can be broken or lost during the repair, resulting in the creation of new noise.
  - tapping or pushing/pulling the component that you suspect is causing the noise.  
Do not tap or push/pull the component with excessive force, otherwise the noise will be eliminated only temporarily.
  - feeling for a vibration with your hand by touching the component(s) that you suspect is (are) causing the noise.
  - placing a piece of paper between components that you suspect are causing the noise.
  - looking for loose components and contact marks.  
Refer to [BL-9. "Generic Squeak and Rattle Troubleshooting"](#).

## REPAIR THE CAUSE

- If the cause is a loose component, tighten the component securely.
- If the cause is insufficient clearance between components:
  - separate components by repositioning or loosening and retightening the component, if possible.
  - insulate components with a suitable insulator such as urethane pads, foam blocks, felt cloth tape or urethane tape. A NISSAN Squeak and Rattle Kit (J-43980) is available through your authorized NISSAN Parts Department.

### **CAUTION:**

**Do not use excessive force as many components are constructed of plastic and may be damaged.**

**Always check with the Parts Department for the latest parts information.**

**The following materials are contained in the NISSAN Squeak and Rattle Kit (J-43980). Each item can be ordered separately as needed.**

**URETHANE PADS [1.5 mm (0.059 in) thick]**

**Insulates connectors, harness, etc.**

**76268-9E005: 100×135 mm (3.94×5.31 in)/76884-71L01: 60×85 mm (2.36×3.35 in)/76884-71L02: 15×25 mm (0.59×0.98 in)**

**INSULATOR (Foam blocks)**

**Insulates components from contact. Can be used to fill space behind a panel.**

**73982-9E000: 45 mm (1.77 in) thick, 50×50 mm (1.97×1.97 in)/73982-50Y00: 10 mm (0.39 in) thick, 50×50 mm (1.97×1.97 in)**

**INSULATOR (Light foam block)**

**80845-71L00: 30 mm (1.18 in) thick, 30×50 mm (1.18×1.97 in)**

**FELT CLOTH TAPE**

**Used to insulate where movement does not occur. Ideal for instrument panel applications.**

**68370-4B000: 15×25 mm (0.59×0.98 in) pad/68239-13E00: 5 mm (0.20 in) wide tape roll. The following materials not found in the kit can also be used to repair squeaks and rattles.**

**UHMW (TEFLON) TAPE**

**Insulates where slight movement is present. Ideal for instrument panel applications.**

# SQUEAK AND RATTLE TROUBLE DIAGNOSIS

## < SERVICE INFORMATION >

### SILICONE GREASE

Used instead of UHMW tape that will be visible or not fit.

Note: Will only last a few months.

### SILICONE SPRAY

Use when grease cannot be applied.

### DUCT TAPE

Use to eliminate movement.

### CONFIRM THE REPAIR

Confirm that the cause of a noise is repaired by test driving the vehicle. Operate the vehicle under the same conditions as when the noise originally occurred. Refer to the notes on the Diagnostic Worksheet.

## Generic Squeak and Rattle Troubleshooting

INFOID:000000004407672

Refer to Table of Contents for specific component removal and installation information.

### INSTRUMENT PANEL

Most incidents are caused by contact and movement between:

1. The cluster lid A and instrument panel
2. Acrylic lens and combination meter housing
3. Instrument panel to front pillar garnish
4. Instrument panel to windshield
5. Instrument panel mounting pins
6. Wiring harnesses behind the combination meter
7. A/C defroster duct and duct joint

These incidents can usually be located by tapping or moving the components to duplicate the noise or by pressing on the components while driving to stop the noise. Most of these incidents can be repaired by applying felt cloth tape or silicone spray (in hard to reach areas). Urethane pads can be used to insulate wiring harness.

### CAUTION:

**Do not use silicone spray to isolate a squeak or rattle. If you saturate the area with silicone, you will not be able to recheck the repair.**

### CENTER CONSOLE

Components to pay attention to include:

1. Shifter assembly cover to finisher
2. A/C control unit and cluster lid C
3. Wiring harnesses behind audio and A/C control unit

The instrument panel repair and isolation procedures also apply to the center console.

### DOORS

Pay attention to the:

1. Finisher and inner panel making a slapping noise
2. Inside handle escutcheon to door finisher
3. Wiring harnesses tapping
4. Door striker out of alignment causing a popping noise on starts and stops

Tapping or moving the components or pressing on them while driving to duplicate the conditions can isolate many of these incidents. You can usually insulate the areas with felt cloth tape or insulator foam blocks from the NISSAN Squeak and Rattle Kit (J-43980) to repair the noise.

### TRUNK

Trunk noises are often caused by a loose jack or loose items put into the trunk by the owner.

In addition look for:

1. Trunk lid bumpers out of adjustment
2. Trunk lid striker out of adjustment
3. The trunk lid torsion bars knocking together
4. A loose license plate or bracket

# SQUEAK AND RATTLE TROUBLE DIAGNOSIS

## < SERVICE INFORMATION >

---

Most of these incidents can be repaired by adjusting, securing or insulating the item(s) or component(s) causing the noise.

### SUNROOF/HEADLINING

Noises in the sunroof/headlining area can often be traced to one of the following:

1. Sunroof lid, rail, linkage or seals making a rattle or light knocking noise
2. Sun visor shaft shaking in the holder
3. Front or rear windshield touching headliner and squeaking

Again, pressing on the components to stop the noise while duplicating the conditions can isolate most of these incidents. Repairs usually consist of insulating with felt cloth tape.

### OVERHEAD CONSOLE (FRONT AND REAR)

Overhead console noises are often caused by the console panel clips not being engaged correctly. Most of these incidents are repaired by pushing up on the console at the clip locations until the clips engage.

In addition look for:

1. Loose harness or harness connectors.
2. Front console map/reading lamp lense loose.
3. Loose screws at console attachment points.

### SEATS

When isolating seat noise it's important to note the position the seat is in and the load placed on the seat when the noise is present. These conditions should be duplicated when verifying and isolating the cause of the noise.

Cause of seat noise include:

1. Headrest rods and holder
2. A squeak between the seat pad cushion and frame
3. The rear seatback lock and bracket

These noises can be isolated by moving or pressing on the suspected components while duplicating the conditions under which the noise occurs. Most of these incidents can be repaired by repositioning the component or applying urethane tape to the contact area.

### UNDERHOOD

Some interior noise may be caused by components under the hood or on the engine wall. The noise is then transmitted into the passenger compartment.

Causes of transmitted underhood noise include:

1. Any component mounted to the engine wall
2. Components that pass through the engine wall
3. Engine wall mounts and connectors
4. Loose radiator mounting pins
5. Hood bumpers out of adjustment
6. Hood striker out of adjustment

These noises can be difficult to isolate since they cannot be reached from the interior of the vehicle. The best method is to secure, move or insulate one component at a time and test drive the vehicle. Also, engine RPM or load can be changed to isolate the noise. Repairs can usually be made by moving, adjusting, securing, or insulating the component causing the noise.

# SQUEAK AND RATTLE TROUBLE DIAGNOSIS

< SERVICE INFORMATION >

## Diagnostic Worksheet

INFOID:000000004407673

Dear Customer:

We are concerned about your satisfaction with your vehicle. Repairing a squeak or rattle sometimes can be very difficult. To help us fix your vehicle right the first time, please take a moment to note the area of the vehicle where the squeak or rattle occurs and under what conditions. You may be asked to take a test drive with a service advisor or technician to ensure we confirm the noise you are hearing.

### SQUEAK & RATTLE DIAGNOSTIC WORKSHEET

#### I. WHERE DOES THE NOISE COME FROM? (circle the area of the vehicle)

The illustrations are for reference only, and may not reflect the actual configuration of your vehicle.

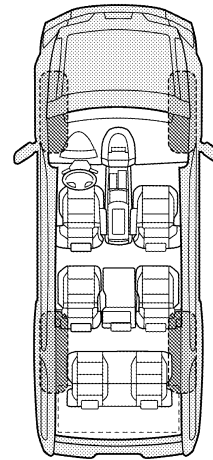
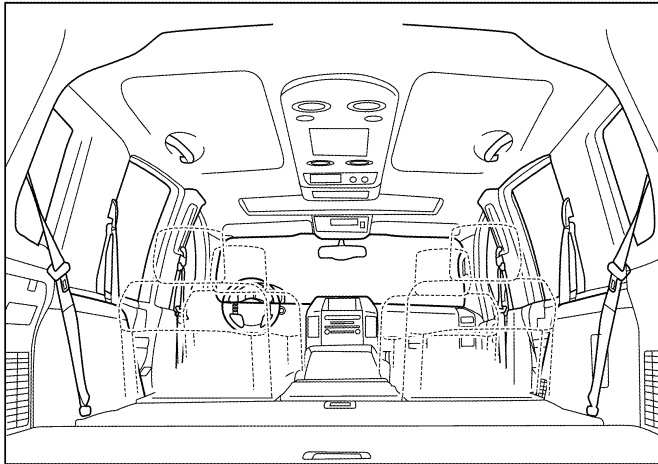
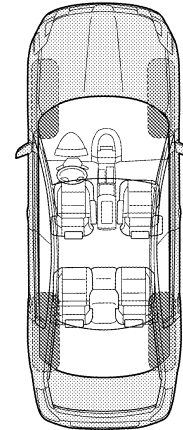
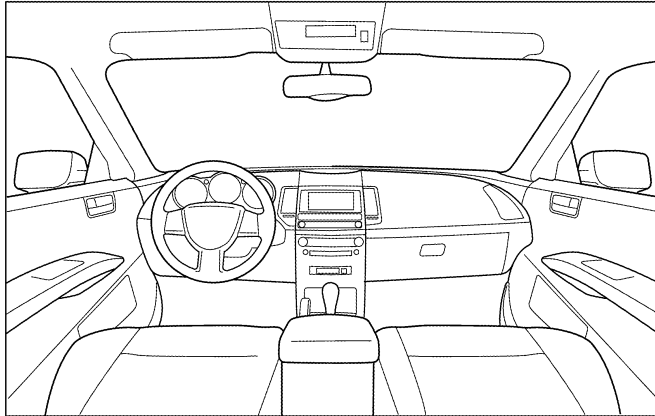

Continue to page 2 of the worksheet and briefly describe the location of the noise or rattle. In addition, please indicate the conditions which are present when the noise occurs.

A  
B  
C  
D  
E  
F  
G  
H  
BL  
J  
K  
L  
M  
N  
O  
P

# SQUEAK AND RATTLE TROUBLE DIAGNOSIS

< SERVICE INFORMATION >

## SQUEAK & RATTLE DIAGNOSTIC WORKSHEET - page 2

Briefly describe the location where the noise occurs:

---

---

### II. WHEN DOES IT OCCUR? (please check the boxes that apply)

- |   |  |
|---|--|
| <input type="checkbox"/> Anytime                      | <input type="checkbox"/> After sitting out in the rain |
| <input type="checkbox"/> 1st time in the morning      | <input type="checkbox"/> When it is raining or wet     |
| <input type="checkbox"/> Only when it is cold outside | <input type="checkbox"/> Dry or dusty conditions       |
| <input type="checkbox"/> Only when it is hot outside  | <input type="checkbox"/> Other:                        |

### III. WHEN DRIVING:

- Through driveways
- Over rough roads
- Over speed bumps
- Only about \_\_\_\_ mph
- On acceleration
- Coming to a stop
- On turns: left, right or either (circle)
- With passengers or cargo
- Other: \_\_\_\_\_
- After driving \_\_\_\_ miles or \_\_\_\_ minutes

### IV. WHAT TYPE OF NOISE

- Squeak (like tennis shoes on a clean floor)
- Creak (like walking on an old wooden floor)
- Rattle (like shaking a baby rattle)
- Knock (like a knock at the door)
- Tick (like a clock second hand)
- Thump (heavy muffled knock noise)
- Buzz (like a bumble bee)

### TO BE COMPLETED BY DEALERSHIP PERSONNEL

#### Test Drive Notes:

---

---

---

	YES	NO	Initials of person performing
Vehicle test driven with customer	<input type="checkbox"/>	<input type="checkbox"/>	_____
- Noise verified on test drive	<input type="checkbox"/>	<input type="checkbox"/>	_____
- Noise source located and repaired	<input type="checkbox"/>	<input type="checkbox"/>	_____
- Follow up test drive performed to confirm repair	<input type="checkbox"/>	<input type="checkbox"/>	_____

VIN: \_\_\_\_\_ Customer Name \_\_\_\_\_  
W.O.# \_\_\_\_\_ Date: \_\_\_\_\_

This form must be attached to Work Order

LAI0071E



# HOOD

< SERVICE INFORMATION >

## HOOD

### Fitting Adjustment

INFOID:000000004407674

SEC. 650

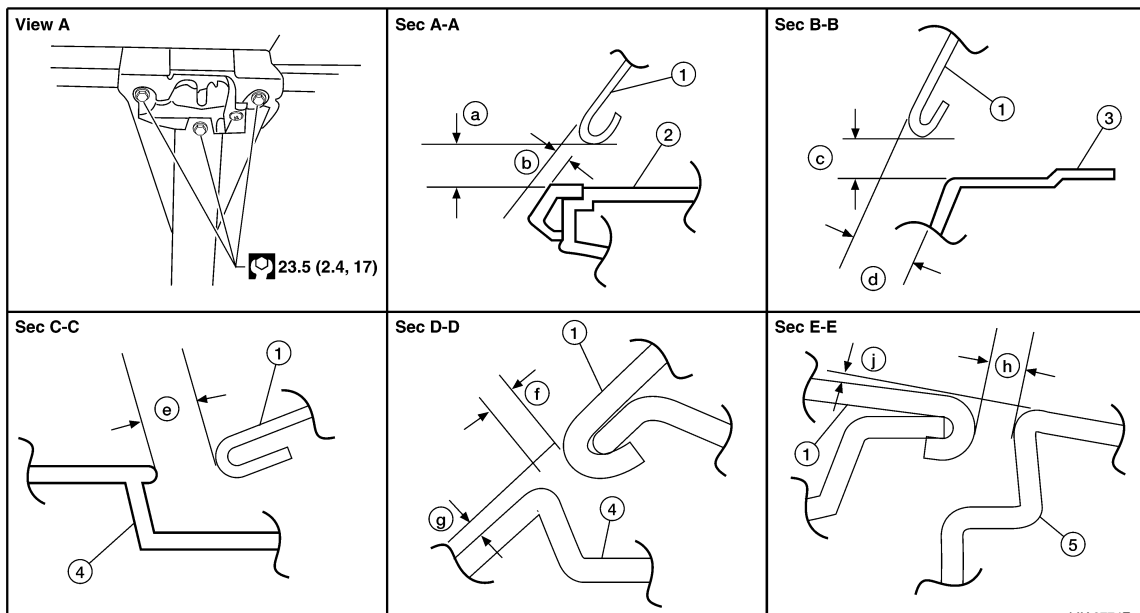
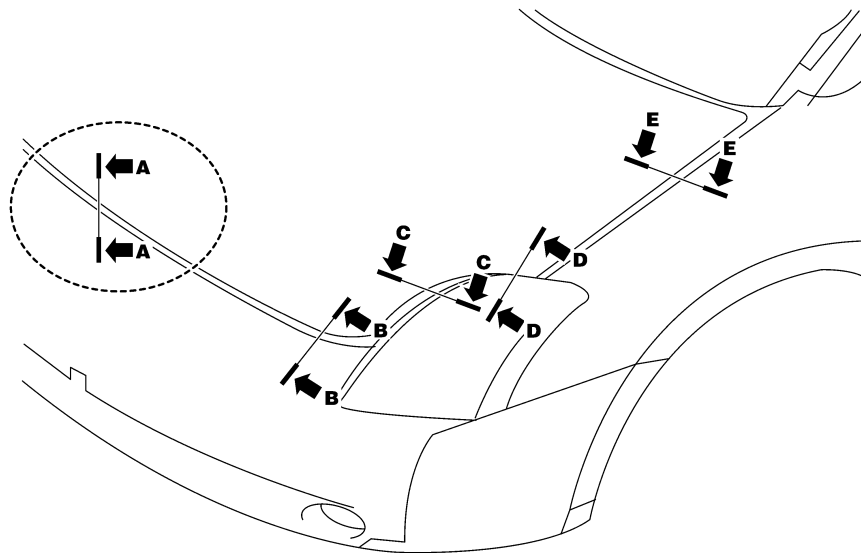

- |   |   |  |
|---|---|--|
| 1. Hood assembly                          | 2. Radiator grille                        | 3. Front bumper fascia                     |
| 4. Headlamp assembly                      | 5. Front fender                           | a. $5.0 \pm 2.0$ mm ( $0.2 \pm 0.08$ in)   |
| b. $2.0 \pm 2.0$ mm ( $0.08 \pm 0.08$ in) | c. $5.0 \pm 2.0$ mm ( $0.2 \pm 0.08$ in)  | d. $2.95 \pm 2.0$ mm ( $0.12 \pm 0.08$ in) |
| e. $4.5 \pm 2.0$ mm ( $0.18 \pm 0.08$ in) | f. $4.5 \pm 2.0$ mm ( $0.18 \pm 0.08$ in) | g. $1.5 \pm 2.0$ mm ( $0.06 \pm 0.08$ in)  |
| h. $3.5 \pm 1.0$ mm ( $0.14 \pm 0.04$ in) | j. $0.0 \pm 1.0$ mm ( $0.0 \pm 0.04$ in)  |  |

### LATERAL/LONGITUDINAL CLEARANCE ADJUSTMENT

1. Remove the front fenders. Refer to [BL-19](#).
2. Seat the hood hinge bolts without torquing.
3. Install the front fenders. Refer to [BL-19](#).
4. Adjust the hood assembly so that the right and left side clearance dimensions are within specification.
5. Remove the front fenders. Refer to [BL-19](#).

# HOOD

## < SERVICE INFORMATION >

6. Tighten the hood hinge bolts to the specified torque.
7. Install the front fenders. Refer to [BL-19](#).

### SURFACE MISMATCH ADJUSTMENT

1. Remove the front grille. Refer to [BL-19](#).
2. Position the hood lock aside.
3. Adjust surface level difference of hood, fender, and headlamp according to the fitting standard dimension, using RH and LH bumper rubbers.
4. Install the hood lock and adjust until the center of the striker and the hood lock are vertically aligned.
5. Press the hood lightly with [approx. 29 N (3 kg)] of force and adjust A and B as shown.

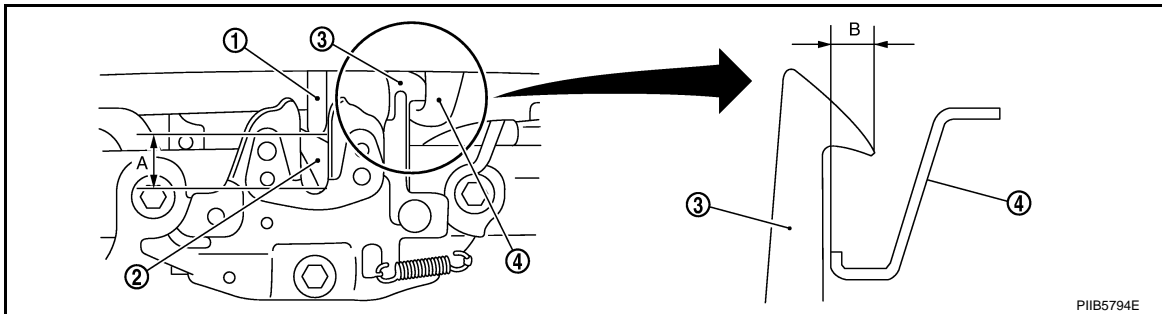

1. Hood striker
2. Primary latch
3. Secondary striker
4. Secondary latch

**A** : 20 mm (0.79 in)

**B** : 6.8 mm (0.268 in) min.

6. After adjustment tighten hood lock bolts to the specified torque.
7. Install the front grille. Refer to [EI-18](#).

### Removal and Installation

INFOID:000000004407675

#### HOOD ASSEMBLY

##### Removal

1. Remove the nuts (a) and the hood assembly (1).

##### **CAUTION:**

**Two technicians should be used to avoid damaging the hood or windshield during removal.**

**Hood hinge nuts** : 14.6 N·m (1.5 kg-m, 11 ft-lb)

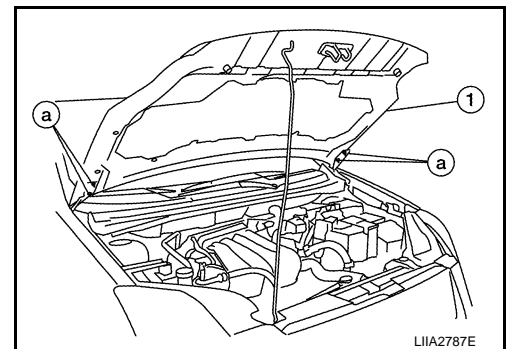

##### Installation

Installation is in the reverse order of removal.

##### **CAUTION:**

- After installing, perform fitting adjustment. Refer to [BL-13, "Fitting Adjustment"](#).

#### HOOD HINGE

##### Removal

1. Remove the hood assembly. Refer to "HOOD ASSEMBLY".
2. Remove the front fender (s). Refer to [BL-19](#).

# HOOD

## < SERVICE INFORMATION >

3. Remove the bolts (a) and the hood hinge (1).

**Hood hinge bolts : 14.6 N-m (1.5 kg-m, 11 ft-lb)**

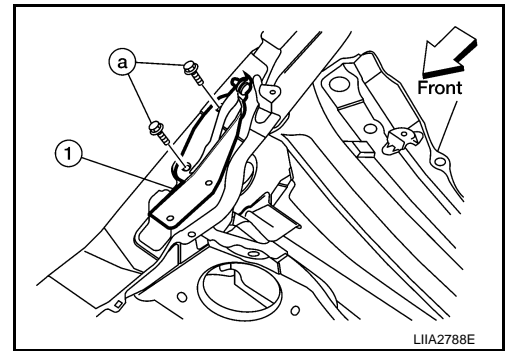

### Installation

Installation is in the reverse order of removal.

### CAUTION:

- Before installing the hood hinge, apply anticorrosive agent to the surface that makes contact with the hoodledge.
- After installing, perform fitting adjustment. Refer to [BL-13, "Fitting Adjustment"](#).

## HOOD LOCK

### Removal

1. Remove the front grille (LH). Refer to [EI-18](#).
2. Remove the hood lock bolts.

**Hood lock bolts : 23.6 N-m (2.4 kg-m, 17 ft-lb)**

3. Remove the hood lock from the hood lock cable.

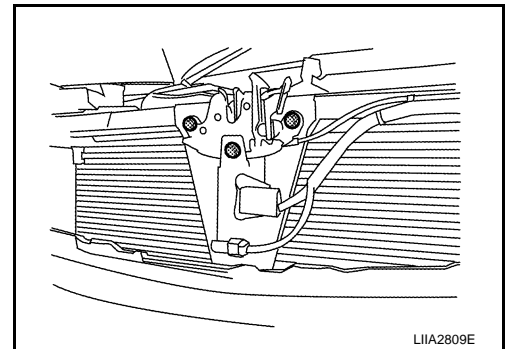

### Installation

Installation is in the reverse order of removal.

### Inspection

### CAUTION:

**If the hood lock cable is bent or deformed, replace it.**

1. Check that the secondary latch is properly engaged with the secondary striker (B: 6.8 mm (0.268 in) by the hood's own weight.

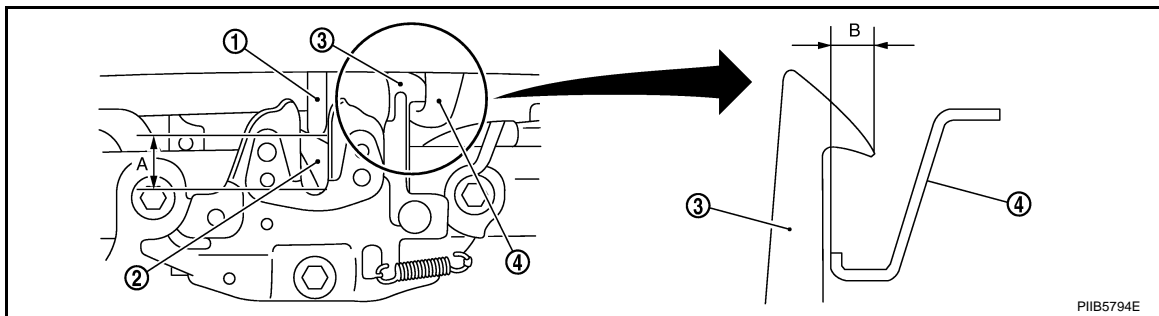

1. Hood striker
4. Secondary latch

2. Primary latch

3. Secondary striker

2. While operating the hood release handle, carefully check that the front end of the hood is raised by approx. 20 mm (0.79 in). Also check that the hood release handle returns to the original position.
3. Check that the secondary hood release operates at 29.4 N (3.0 kg) or below.

# HOOD

## < SERVICE INFORMATION >

4. Confirm that the static closing force of the hood is 343 – 441 N·m (35 – 44 kg·m).
5. Check the hood lock lubrication condition. If necessary, apply “body grease” to the points as shown.

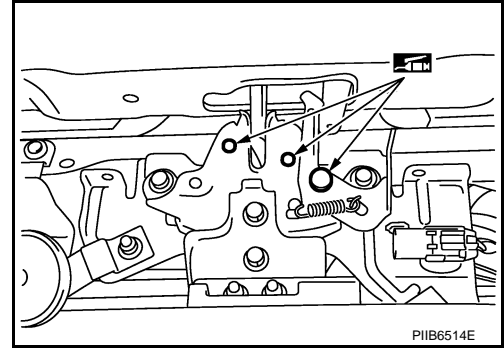

## HOOD LOCK CABLE

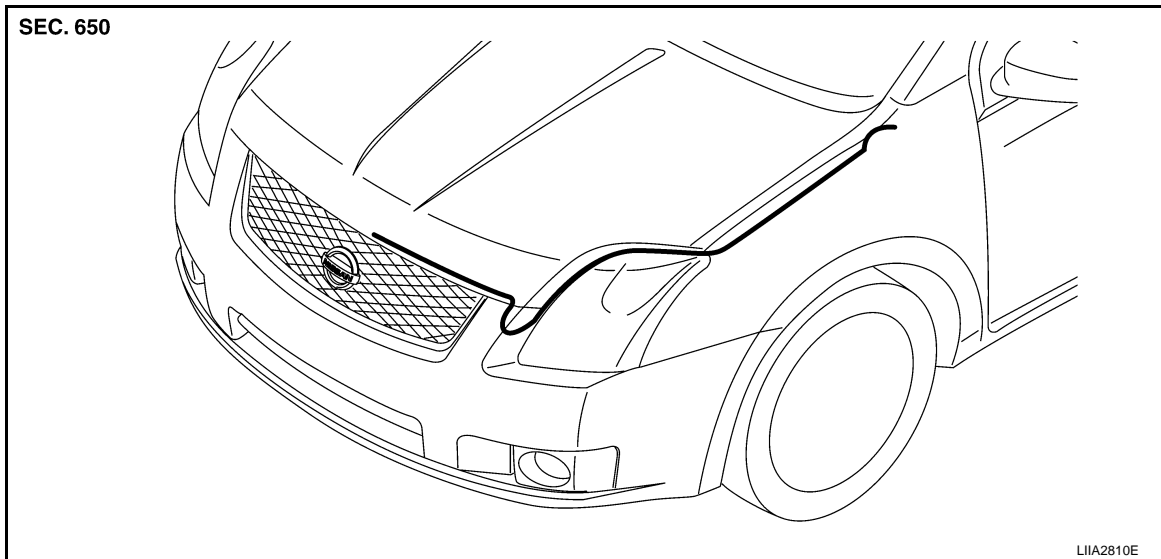

### Removal

1. Remove the front grille (LH/RH). Refer to [EI-18](#).
2. Remove the fender protector (LH). Refer to [EI-21](#).
3. Remove the hood lock. Refer to "HOOD LOCK".
4. Disconnect the hood lock cable from the radiator core support and the underside of the hoodledge.
5. Remove the instrument lower finisher. Refer to [IP-11](#).
6. Push the grommet from the upper dash into the passenger compartment and remove the hood lock cable.

### CAUTION:

**While pulling the cable, be careful not to damage (peel) hood opener cable outer surface on edges of body through hole.**

### Installation

1. Pull the hood lock cable through the hole in the upper dash and into the wheel well.

### CAUTION:

**Be careful not to bend the cable too much, keeping the radius 100 mm (3.94 in) or more.**

2. Check that the cable is not offset from the positioning grommet, and push the grommet into the upper dash hole securely.
3. Apply sealant around the grommet (at \* mark).

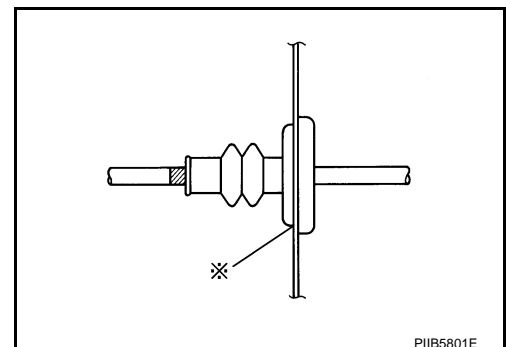

# HOOD

## < SERVICE INFORMATION >

4. Connect the hood lock cable to hood lock.
5. After installing, check the hood lock adjustment and the hood opener operation. Refer to [BL-13. "Fitting Adjustment"](#).

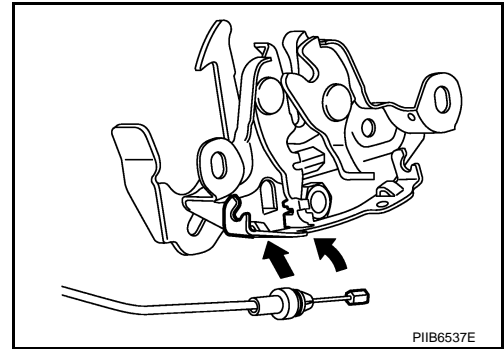

A

B

C

D

E

F

G

H

BL

J

K

L

M

N

O

P

# RADIATOR CORE SUPPORT

< SERVICE INFORMATION >

## RADIATOR CORE SUPPORT

### Removal and Installation

INFOID:000000004407676

#### REMOVAL

1. Remove the hood. Refer to [BL-14, "Removal and Installation"](#).
2. Remove the front bumper reinforcement. Refer to [EI-16](#).
3. Remove the hood lock assembly. Refer to [BL-14, "Removal and Installation"](#).
4. Remove the air duct. Refer to [EM-16, "Removal and Installation"](#) (MR20DE) or [EM-131, "Removal and Installation"](#) (QR25DE).
5. Remove both headlamps. Refer to [LT-23, "Removal and Installation"](#).
6. Remove the crash zone sensor.
7. Remove the I-key buzzer.
8. Remove the horn. Refer to [WW-27](#).
9. Remove the air guide and hood lock cable clip.
10. Remove the washer tank. Refer to [WW-22, "Removal and Installation of Washer Fluid Reservoir"](#).
11. Remove the radiator. Refer to [CO-15, "Removal and Installation"](#) (MR20DE) or [CO-43, "Removal and Installation"](#) (QR25DE).
12. Remove the AC condenser. Refer to [MTC-87, "Removal and Installation for Condenser"](#).
13. Remove the bolts (a) and the radiator core support (1).

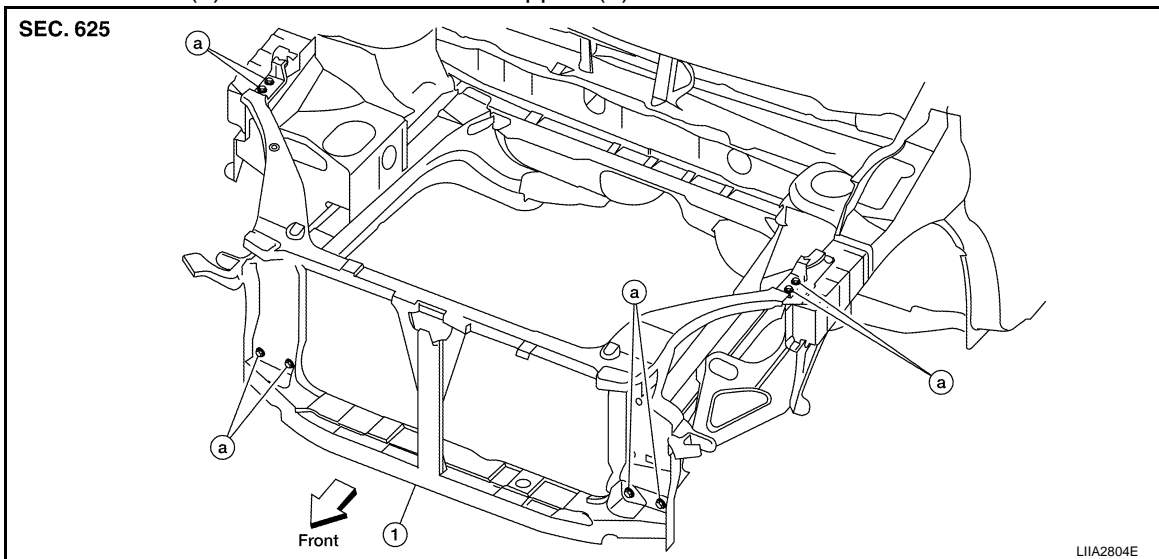

#### INSTALLATION

Installation is in the reverse order of removal.

# FRONT FENDER

< SERVICE INFORMATION >

## FRONT FENDER

### Removal and Installation

INFOID:000000004407677

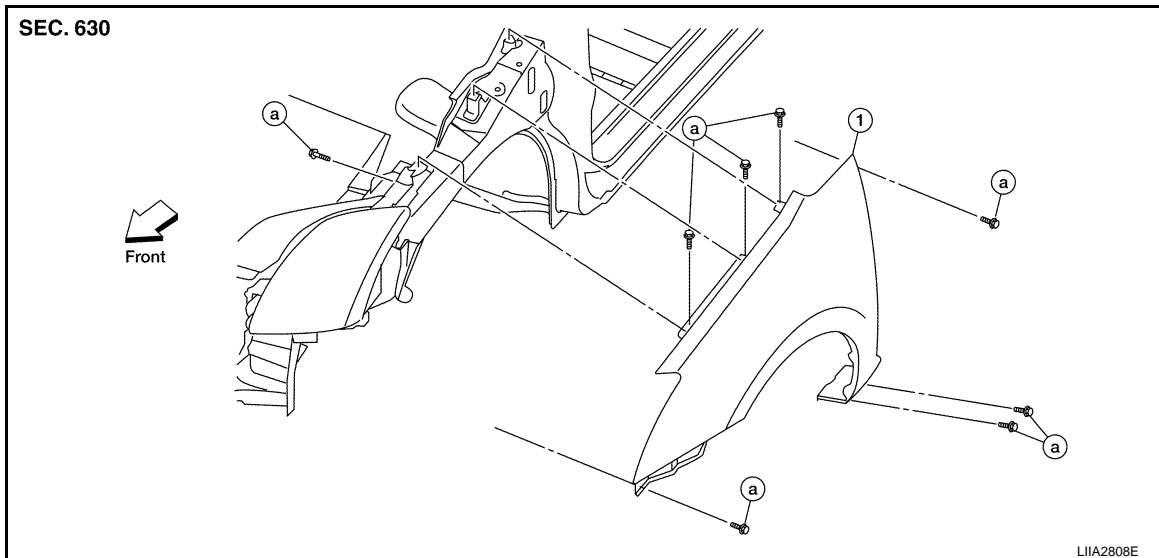

1. Front fender

2 Bolts

#### REMOVAL

1. Remove the headlamp assemblies. Refer to [LT-23, "Removal and Installation"](#).
2. Remove the cowl top cover (LH/RH). Refer to [EI-19](#).
3. Remove the front fender protector. Refer to [EI-21](#).
4. Remove the bolts (a) and the front fender (1).

#### **CAUTION:**

**While removing use a shop cloth to protect the vehicle body from damage.**

#### INSTALLATION

Installation is in the reverse order of removal.

#### **CAUTION:**

- After installing, apply touch-up paint onto the head of the front fender bolts.

# POWER DOOR LOCK SYSTEM

< SERVICE INFORMATION >

## POWER DOOR LOCK SYSTEM

### Component Parts and Harness Connector Location

INFOID:000000004407678

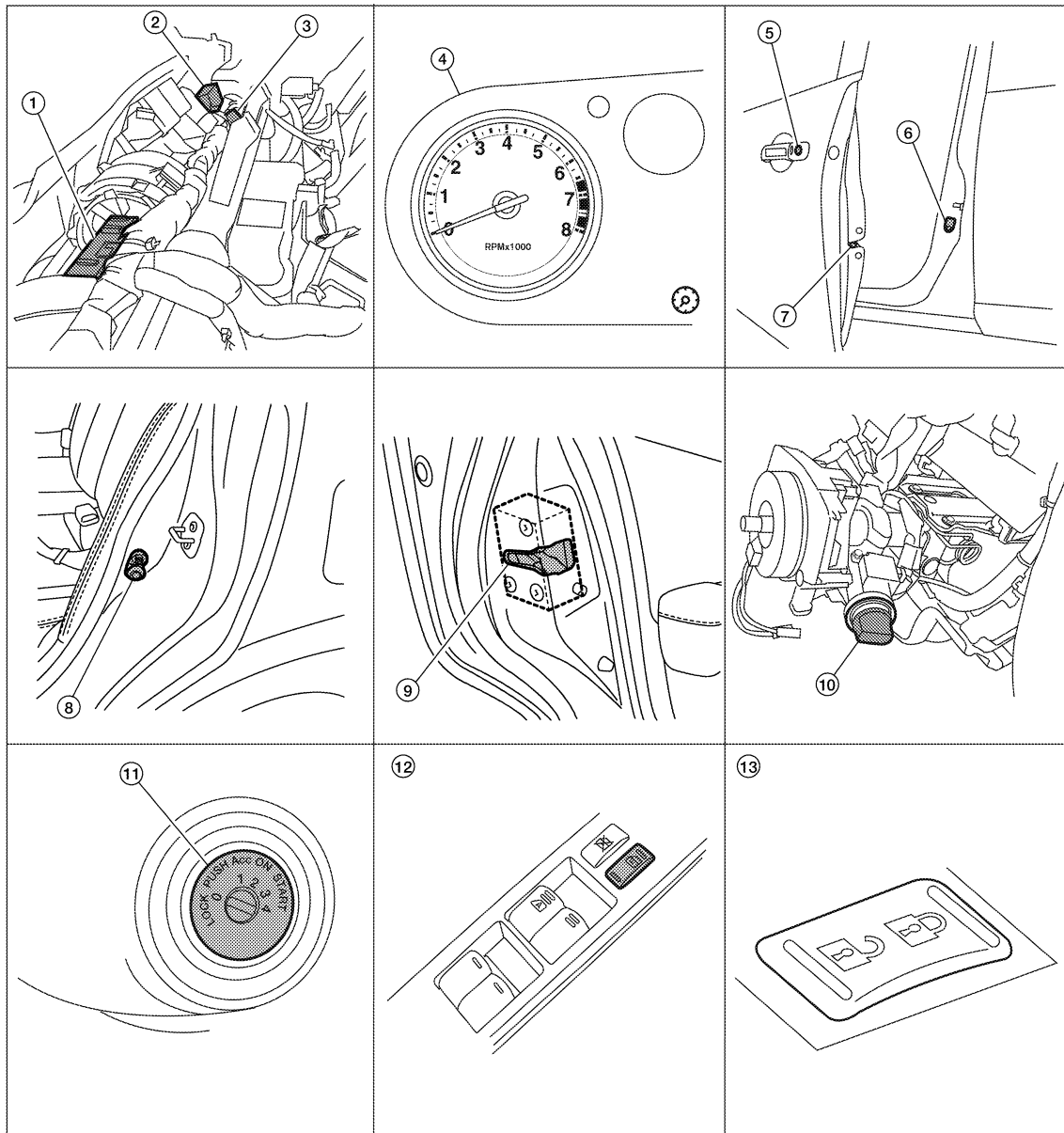

ALKIA1781ZZ

- |  |  |   |
|--|--|---|
| 1. BCM M18, M19, M20<br>(view with instrument panel removed)             | 2. Intelligent Key unit M42<br>(with Intelligent Key)      | 3. Passenger select unlock relay M14<br>(with Intelligent Key)  |
| 4. Combination meter M24   | 5. Front door lock assembly LH (key<br>cylinder switch) D9 | 6. Front door switch LH B21, RH B28   |
| 7. Front door lock assembly (actuator) LH<br>D9, RH D107                 | 8. Rear door switch LH B26, RH B41                         | 9. Rear door lock actuator LH D202, RH<br>D302  |
| 10. Key switch and ignition knob switch<br>M49<br>(with Intelligent Key) | 11. Key switch M50<br>(without Intelligent Key)            | 12. Main power window and door lock/unlock<br>switch D5, D11 (with power windows)<br>Power window and door lock/unlock<br>switch RH D104 (with power windows) |
| 13. Door lock/unlock switch LH D6<br>(without power windows)             |  |   |

### System Description

INFOID:000000004407679

Power is supplied at all times

- through 50A fusible link (letter j, located in the fuse and fusible link box)



# POWER DOOR LOCK SYSTEM

## < SERVICE INFORMATION >

- to BCM terminal 70
  - through 10A fuse [No. 21, located in the fuse block (J/B)]
  - to BCM terminal 57
  - through 10A fuse [No. 19, located in the fuse block (J/B)]
  - to key switch terminal 2 (without Intelligent Key system)
  - through 10A fuse [No. 9, located in the fuse block (J/B)]
  - to key switch and ignition knob switch terminals 2 and 4 (with Intelligent Key system).
- When key switch is ON (key is inserted in ignition key cylinder), power is supplied
- through key switch terminal 1 (without Intelligent Key system) or key switch and ignition knob terminal 1 (with Intelligent Key system)
  - to BCM terminal 37.
- Ground is supplied
- to BCM terminal 67
  - through body grounds M57 and M61.

## LOCK OPERATION

When the door is locked with main power window and door lock/unlock switch (with power windows) or with door lock/unlock switch LH (without power windows), ground is supplied

- to BCM terminal 45
- through main power window and door lock and unlock switch terminals 18 and 17
- through body grounds M57 and M61.

With power windows, when the door is locked with power window and door lock/unlock switch RH, ground is supplied

- to BCM terminal 45
- through power window and door lock and unlock switch RH terminals 1 and 3
- through body grounds M57 and M61.

When the door is locked with front door key cylinder switch LH, ground is supplied

- to BCM terminal 8
- through front door key cylinder switch LH terminals 4 and 6
- through body grounds M57 and M61.

## UNLOCK OPERATION

When the door is unlocked with main power window and door lock/unlock switch (with power windows) or with door lock/unlock switch LH (without power windows), ground is supplied

- to BCM terminal 46
- through main power window and door lock/unlock switch terminals 6 and 17
- through body grounds M57 and M61.

With power windows, when the door is unlocked with power window and door lock/unlock switch RH, ground is supplied

- to BCM terminal 46
- through power window and door lock and unlock switch RH terminals 2 and 3
- through body grounds M57 and M61.

When the door is unlocked with front door key cylinder switch LH, ground is supplied

- to BCM terminal 7
- through front door key cylinder switch LH terminals 4 and 5
- through body grounds M57 and M61.

When the front door switch LH is ON (door is OPEN), ground is supplied

- to BCM terminal 47
- through front door switch LH terminal 2
- through front door switch LH case ground.

When the front door switch RH is ON (door is OPEN), ground is supplied

- to BCM terminal 12
- through front door switch RH terminal 2
- through front door switch RH case ground.

When the rear door switch LH is ON (door is OPEN), ground is supplied

- to BCM terminal 48
- through rear door switch LH terminal 2
- through rear door switch LH case ground.

When the rear door switch RH is ON (door is OPEN), ground is supplied

- to BCM terminal 13
- through rear door switch RH terminal 2
- through rear door switch RH case ground.

A

B

C

D

E

F

G

H

BL

J

K

L

M

N

O

P

# POWER DOOR LOCK SYSTEM

## < SERVICE INFORMATION >

---

### OUTLINE

Functions available by operating the inside door lock and unlock switches

- Interlocked with the locking operation of door lock and unlock switch, door lock actuators of all doors are locked.
- Interlocked with the unlocking operation of door lock and unlock switch, door lock actuators of all doors are unlocked.

Functions available by operating the front door key cylinder switch LH

- Interlocked with the locking operation of front door key cylinder switch LH, door lock actuators of all doors are locked.
- When front door key cylinder switch LH is unlocked, front door lock actuator LH is unlocked.
- When front door key cylinder switch LH is unlocked for the second time within 5 seconds after the first operation, door lock actuators on all doors are unlocked.

Key reminder door system

When door lock and unlock switch is operated to lock doors with ignition key inserted in key cylinder and any door open, all door lock actuators are locked and then unlocked.

### AUTOMATIC DOOR LOCKS (LOCK OPERATION)

The interlock door lock function is the function that locks all doors linked with the vehicle speed.

Vehicle Speed Sensing Auto Door Lock\*1

All doors are locked when the vehicle speed reaches 24 km/h (15 MPH) or more.

BCM outputs the lock signal to all door lock actuators when it detects that the ignition switch is turned ON, all doors are closed and the vehicle speed received from the combination meter via CAN communication becomes 15 MPH (24 km/h) or more.

If a door is opened and closed at any time during one ignition cycle (OFF → ON), even after initial auto door lock has taken place, the BCM will relock all doors when the vehicle speed reaches 15 MPH (24 km/h) or more again.

Setting change of Automatic Door Locks (LOCK) Function

The lock operation setting of the automatic door locks function can be changed.

#### With CONSULT-III

The ON/OFF switching of the automatic door locks (LOCK) function and the type selection of the automatic door locks (LOCK) function can be performed at the WORK SUPPORT setting of CONSULT-III. Refer to [BL-36, "CONSULT-III Function \(BCM\)"](#).

#### Without CONSULT- III

The automatic door locks (LOCK) function can be switched ON/OFF by performing the following operation.

1. Close all doors (door switch OFF).
2. Turn ignition switch ON.
3. Within 20 seconds of turning the ignition switch ON, press and hold the door lock and unlock switch to the LOCK position for more than 5 seconds.
4. The switching is completed when the hazard lamps blink.

OFF → ON : 2 blinks

ON → OFF : 1 blink

5. The ignition switch must be turned OFF and ON again between each setting change.

### AUTOMATIC DOOR LOCKS (UNLOCK OPERATION)

The automatic door locks (UNLOCK) function is the function that unlocks all doors linked with the key position.

IGN OFF Interlock Door Unlock\*1

For vehicles equipped with Intelligent Key system, all doors are unlocked when the power supply position is changed from ON to OFF.

For vehicles not equipped with Intelligent Key system, all doors are unlocked when the mechanical key is removed from the ignition key cylinder.

BCM outputs the unlock signal to all door lock actuators when it detects that the power supply position is changed from ignition switch ON to OFF (with Intelligent Key) or when the mechanical key is removed from the ignition key cylinder (without Intelligent Key).

Setting change of Automatic Door Locks (UNLOCK) Function

# POWER DOOR LOCK SYSTEM

## < SERVICE INFORMATION >

The lock operation setting of the automatic door locks function can be changed.

### Ⓜ With CONSULT-III

The ON/OFF switching of the automatic door locks (UNLOCK) function and the type selection of the automatic door locks (UNLOCK) function can be performed at the WORK SUPPORT setting of CONSULT-III. Refer to [BL-36. "CONSULT-III Function \(BCM\)".](#)

### ⓧ Without CONSULT- III

The automatic door locks (UNLOCK) function can be switched ON/OFF by performing the following operation.

1. Close all doors (door switch OFF).
2. Turn ignition switch ON.
3. Within 20 seconds of turning the ignition switch ON, press and hold the door lock and unlock switch to the UNLOCK position for more than 5 seconds.
4. The switching is completed when the hazard lamps blink.

OFF → ON : 2 blinks

ON → OFF : 1 blink

5. The ignition switch must be turned OFF and ON again between each setting change.

\*1: This function is set to ON before delivery.

## CAN Communication System Description

INFOID:000000004407680

Refer to [LAN-6. "System Description".](#)

A  
B  
C  
D  
E  
F  
G  
H  
J  
K  
L  
M  
N  
O  
P

BL

# POWER DOOR LOCK SYSTEM

< SERVICE INFORMATION >

## Schematic (Without Intelligent Key)

INFOID:000000004407681

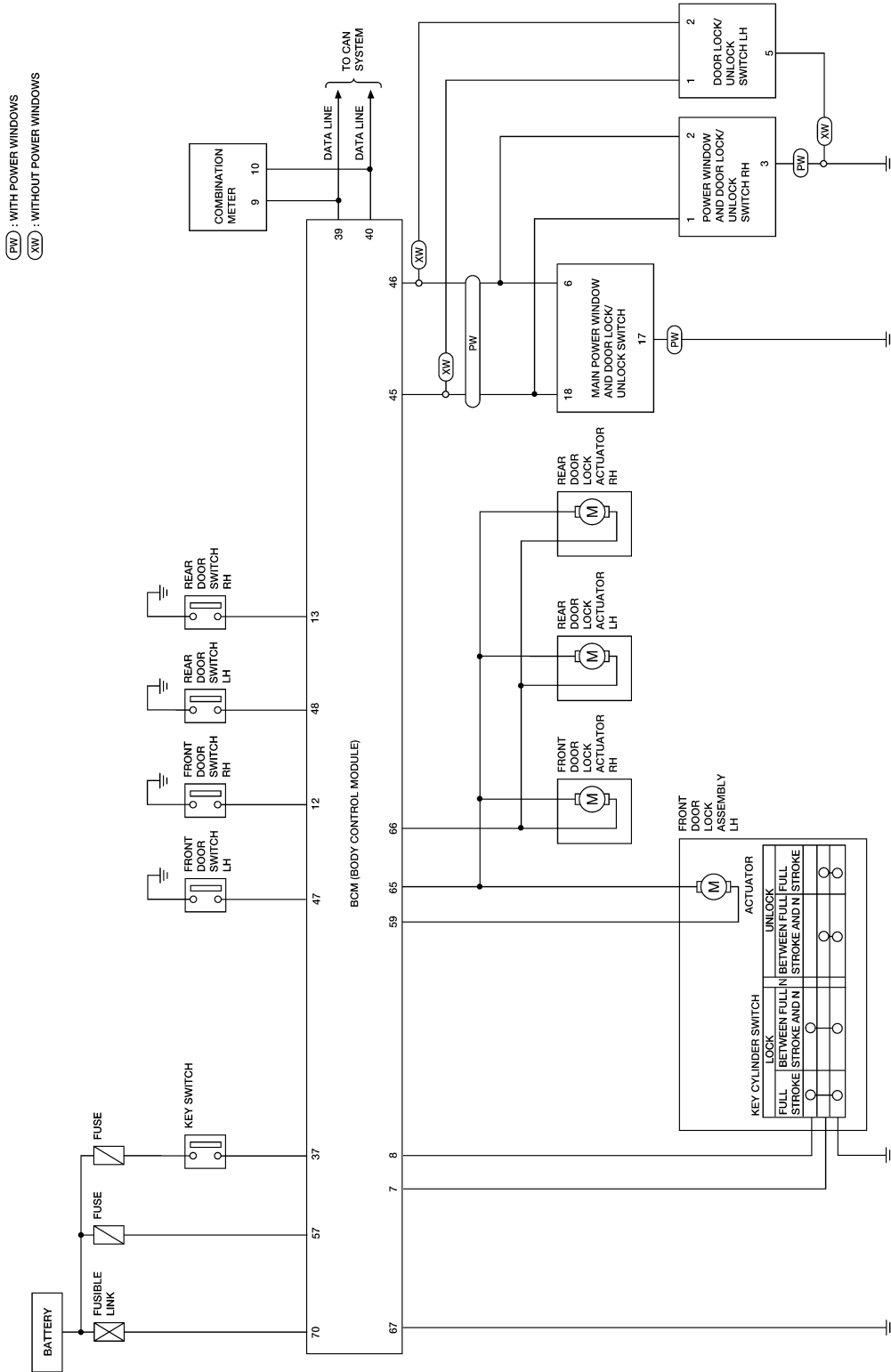

ABKWA0321GE

# POWER DOOR LOCK SYSTEM

< SERVICE INFORMATION >

## Wiring Diagram - D/LOCK - (Without Intelligent Key)

INFOID:000000004407682

BL-D/LOCK-01

— : DATA LINE

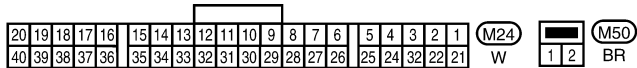
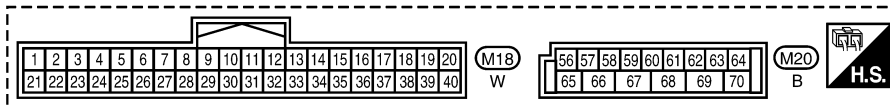
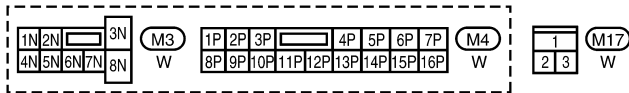
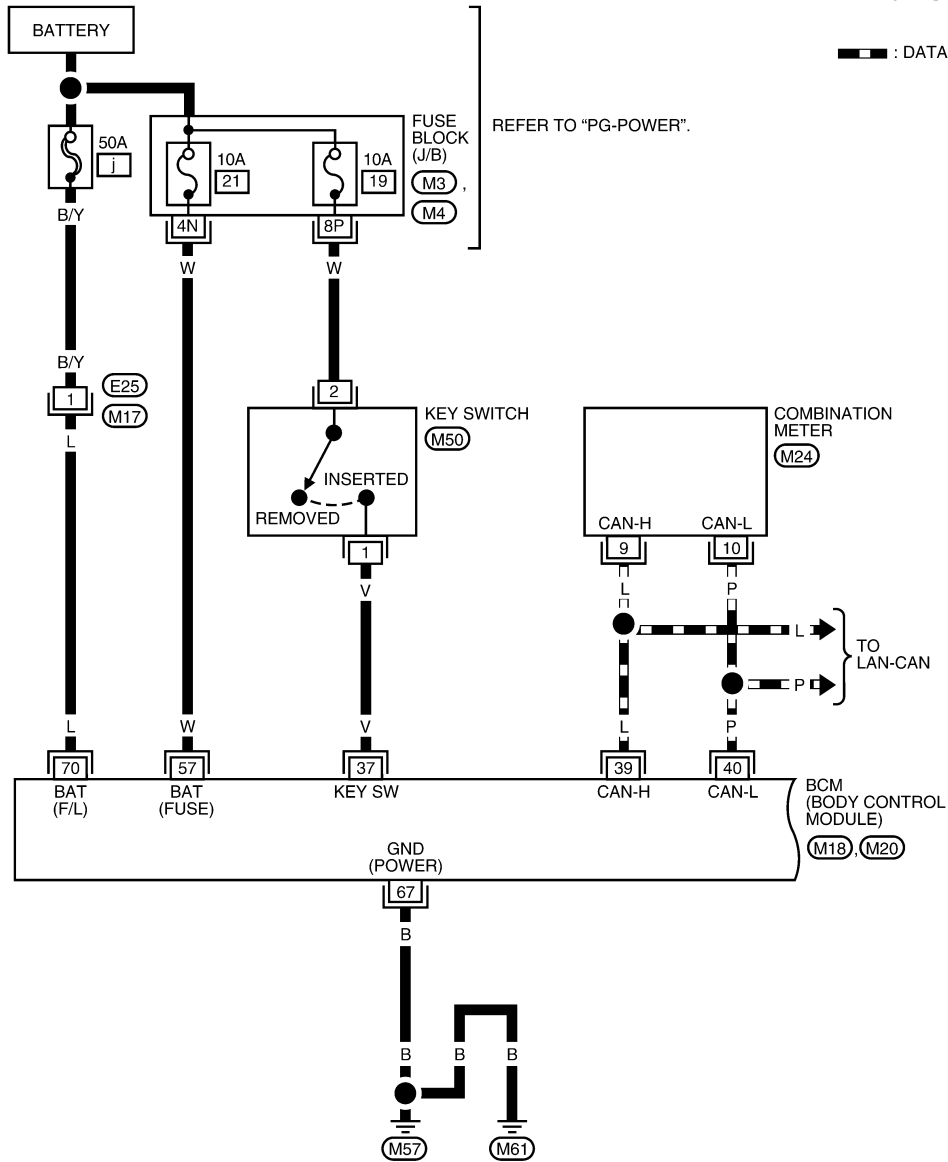

ABKWA0322GE

# POWER DOOR LOCK SYSTEM

< SERVICE INFORMATION >

BL-D/LOCK-02

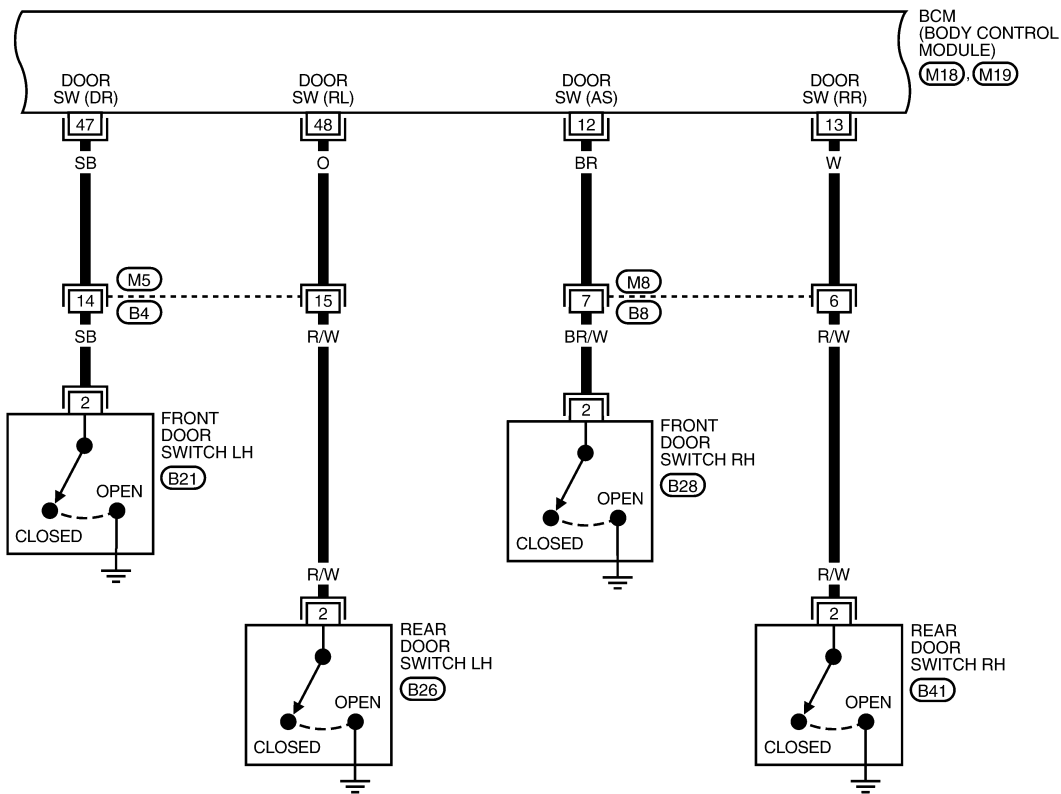

1	2	3	4	5	6	7	M5	M8		
8	9	10	11	12	13	14	15	16	GR	W

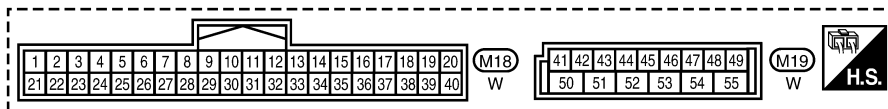

1	
2	B21, B26, B28, B41
3	W, W, W, W

WIWA2176E

# POWER DOOR LOCK SYSTEM

< SERVICE INFORMATION >

BL-D/LOCK-03

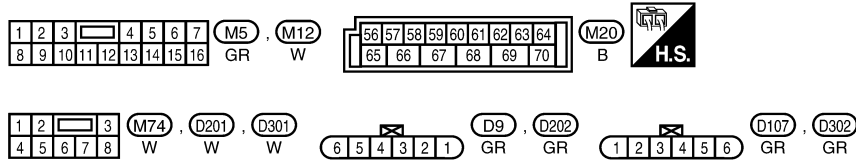
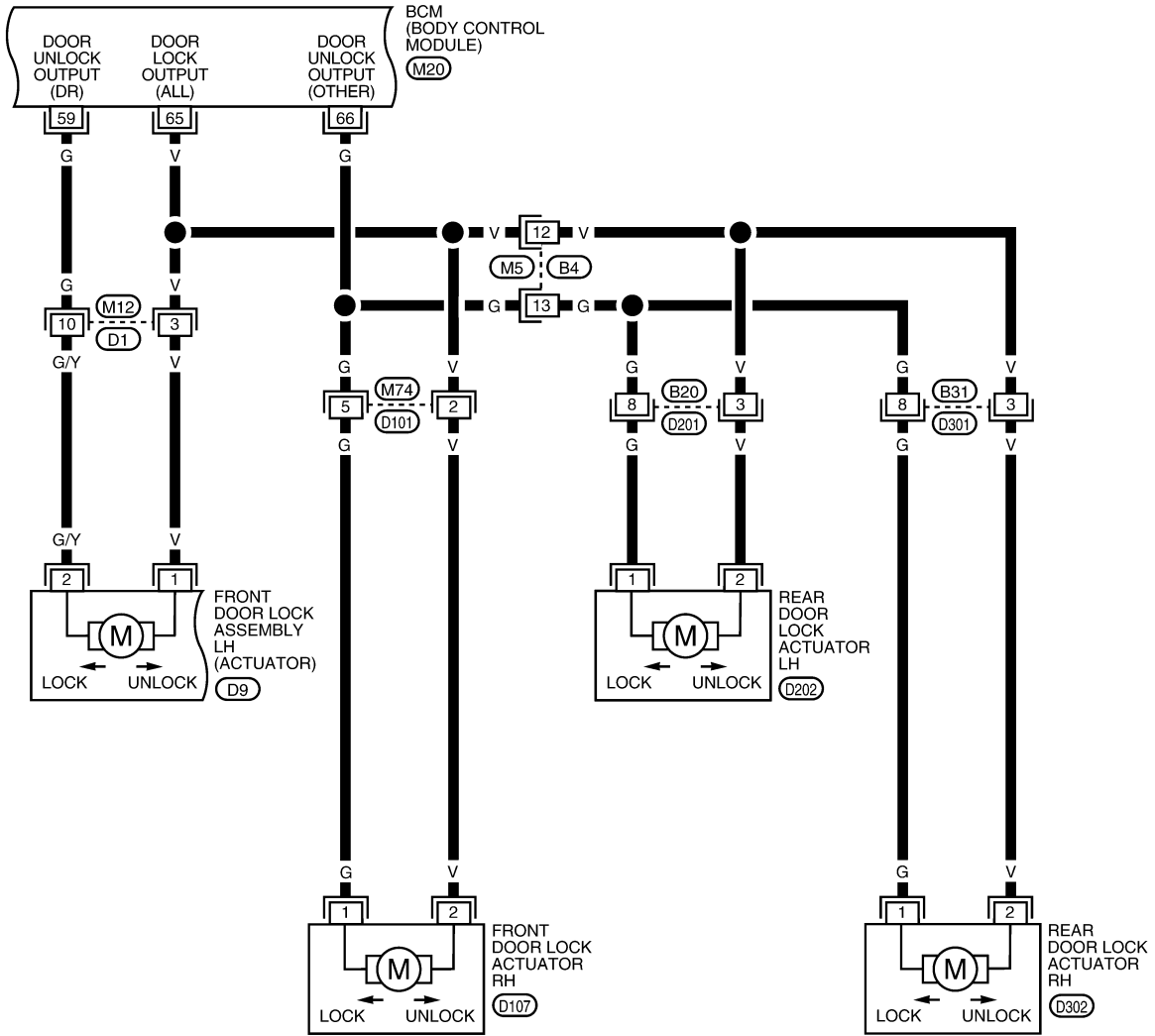

AWKWA0095GI

# POWER DOOR LOCK SYSTEM

< SERVICE INFORMATION >

With Power Windows

BL-D/LOCK-04

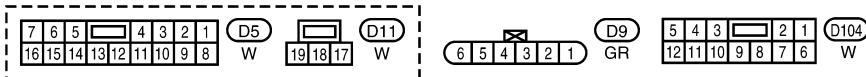
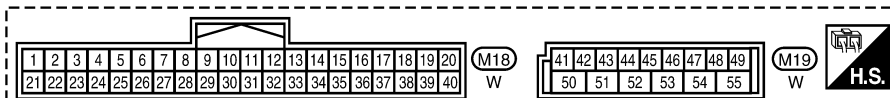
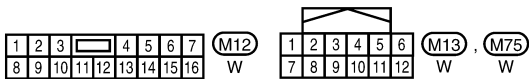
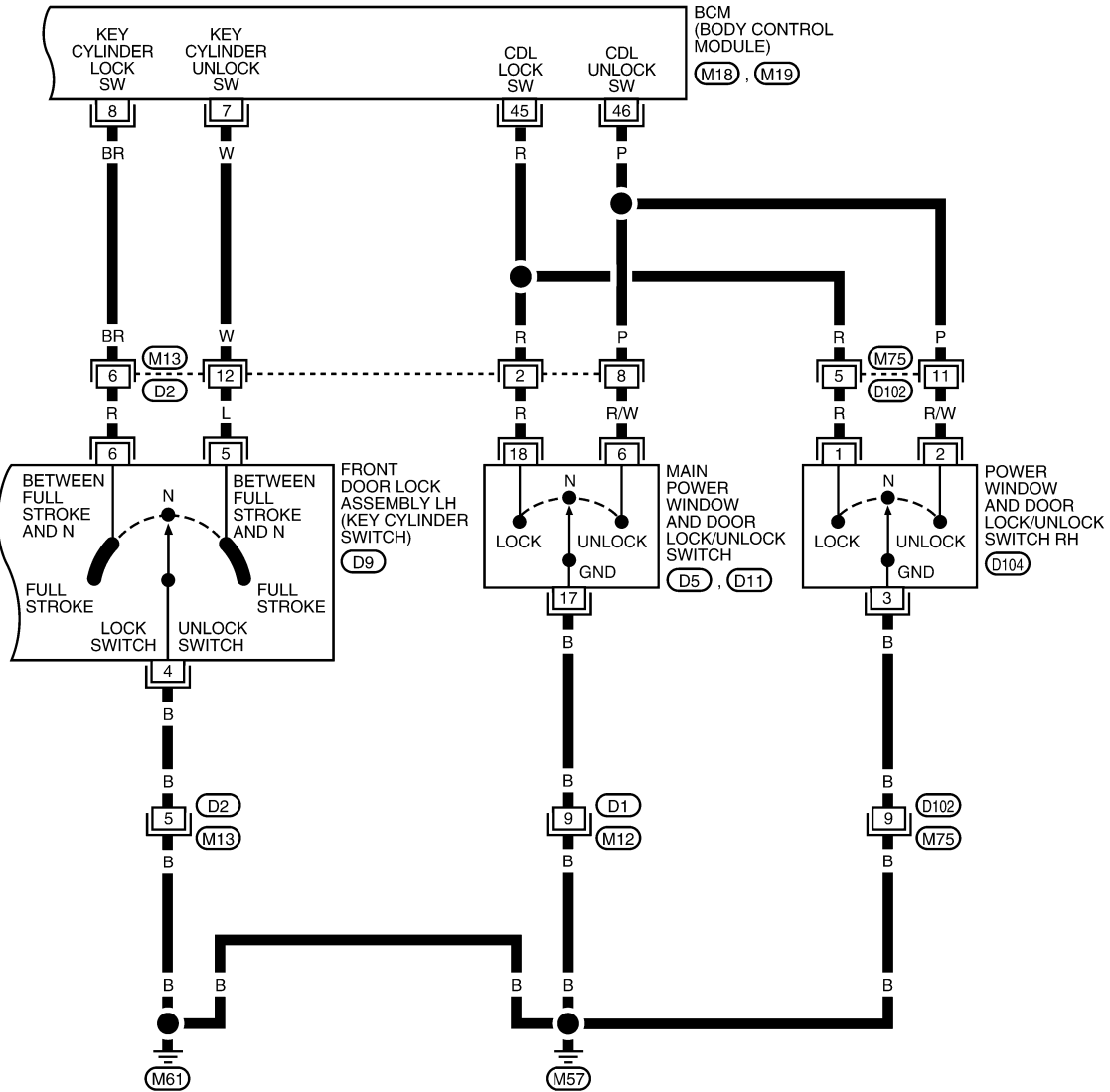

ABKWA0323GE



# POWER DOOR LOCK SYSTEM

< SERVICE INFORMATION >

Without Power Windows

BL-D/LOCK-05

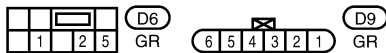
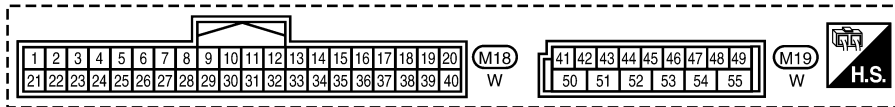
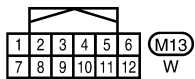
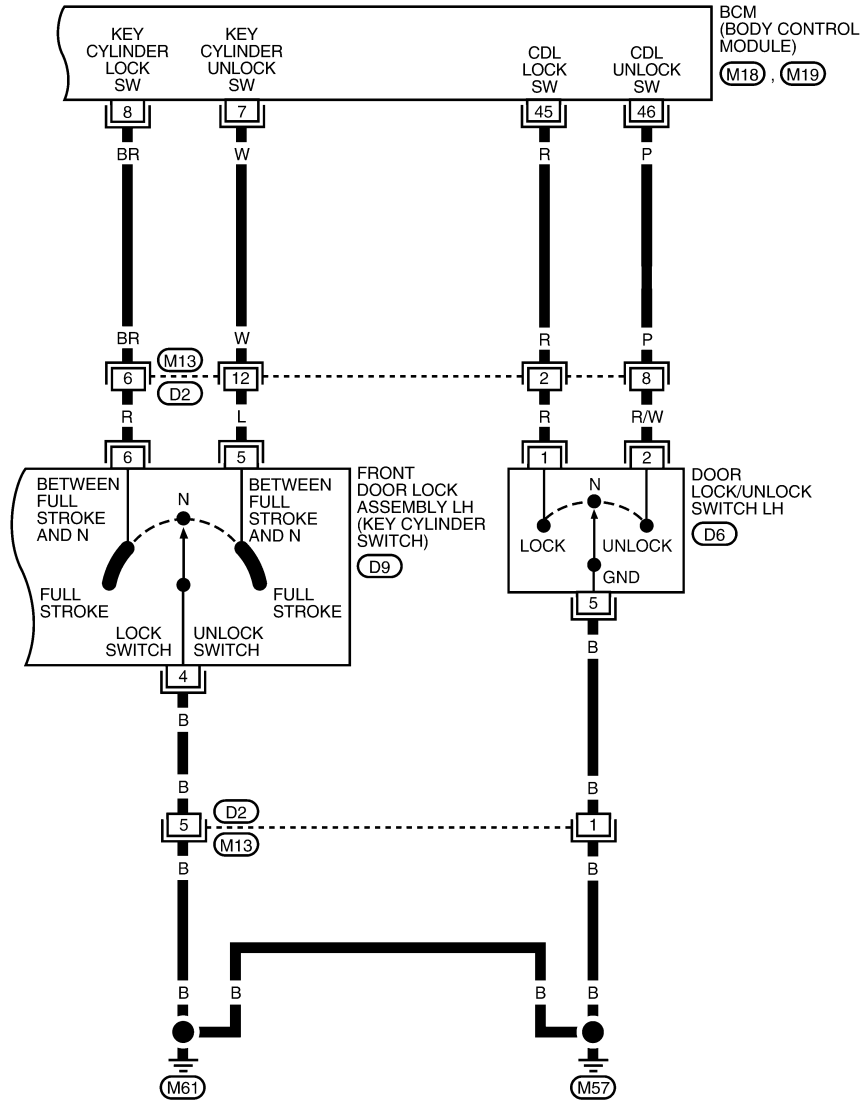

WIWA2179E

# POWER DOOR LOCK SYSTEM

< SERVICE INFORMATION >

## Schematic (With Intelligent Key)

INFOID:000000004407683

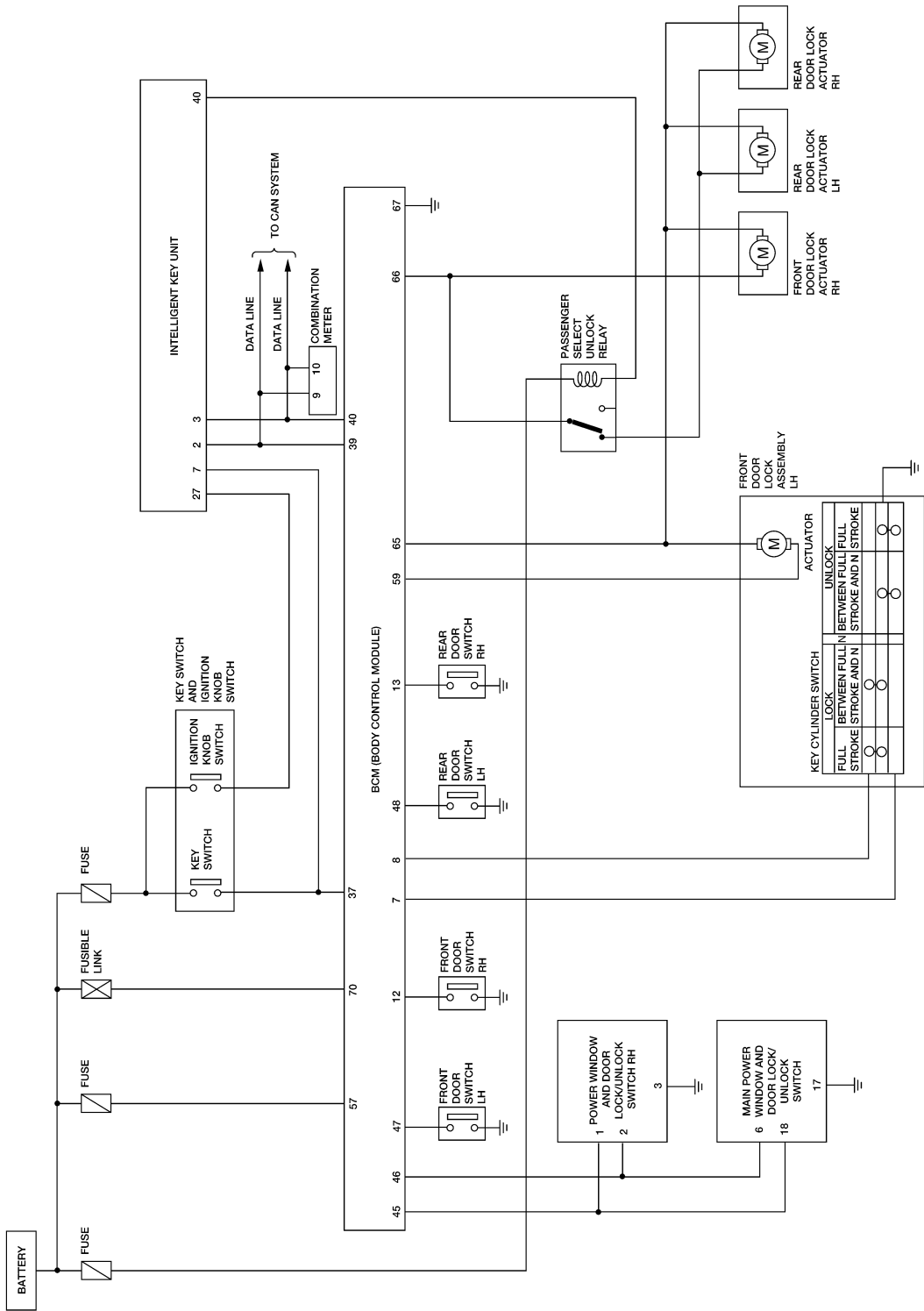

ABKWA0324GE

# POWER DOOR LOCK SYSTEM

< SERVICE INFORMATION >

## Wiring Diagram - D/LOCK - (With Intelligent Key)

INFOID:000000004407684

BL-D/LOCK-06

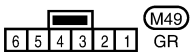
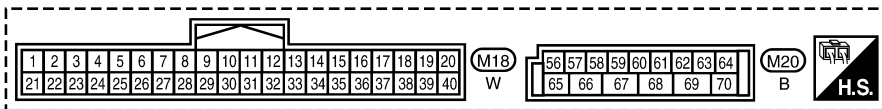
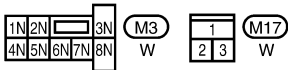
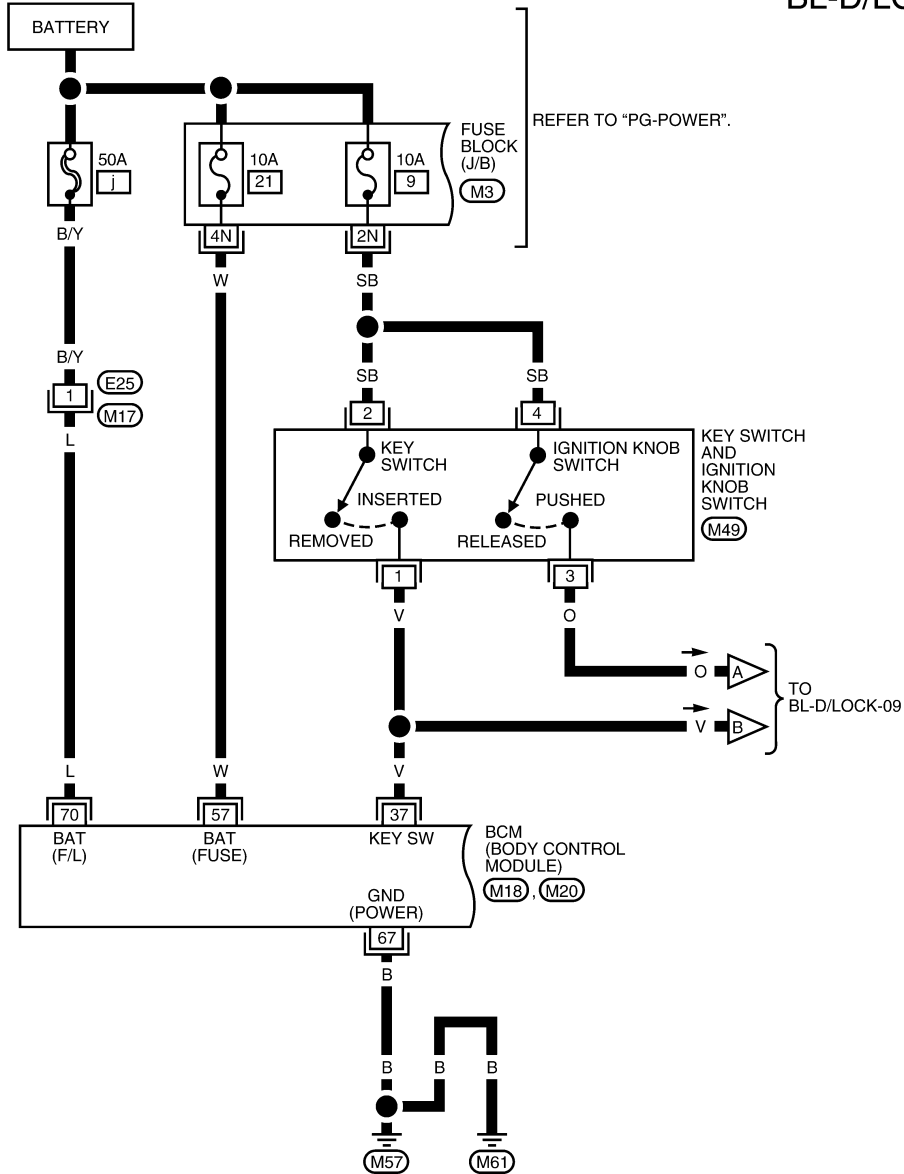

WIWA2181E

# POWER DOOR LOCK SYSTEM

< SERVICE INFORMATION >

BL-D/LOCK-07

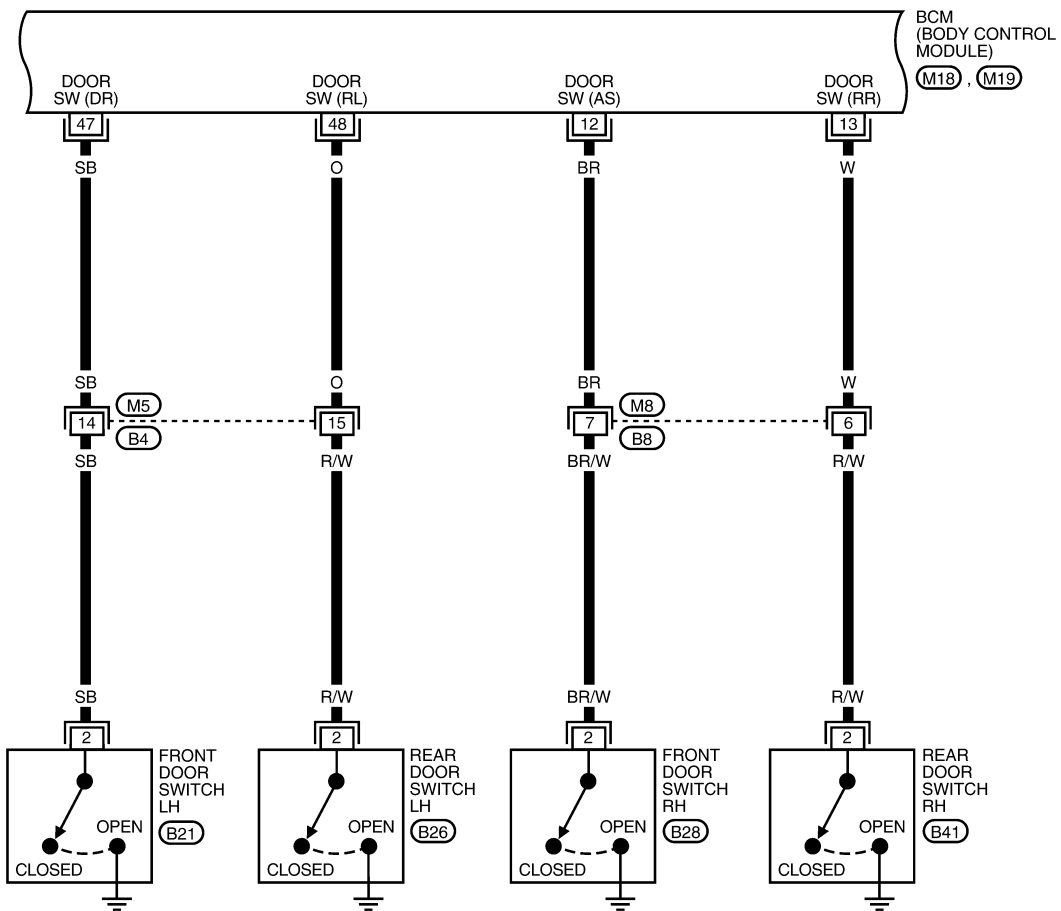

1	2	3	4	5	6	7	(M5)	(M8)		
8	9	10	11	12	13	14	15	16	GR	W

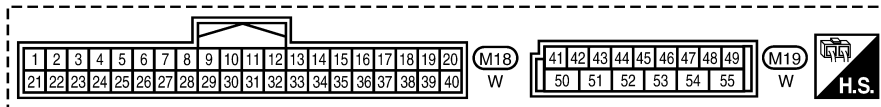

1	(B21)	(B26)	(B28)	(B41)
2	W	W	W	W
3				

WIWA2182E

# POWER DOOR LOCK SYSTEM

< SERVICE INFORMATION >

BL-D/LOCK-08

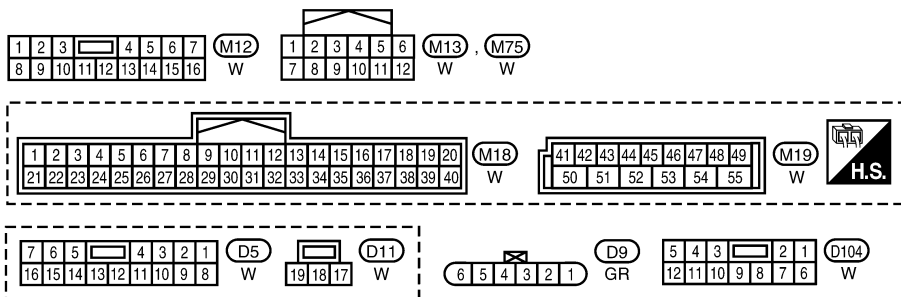
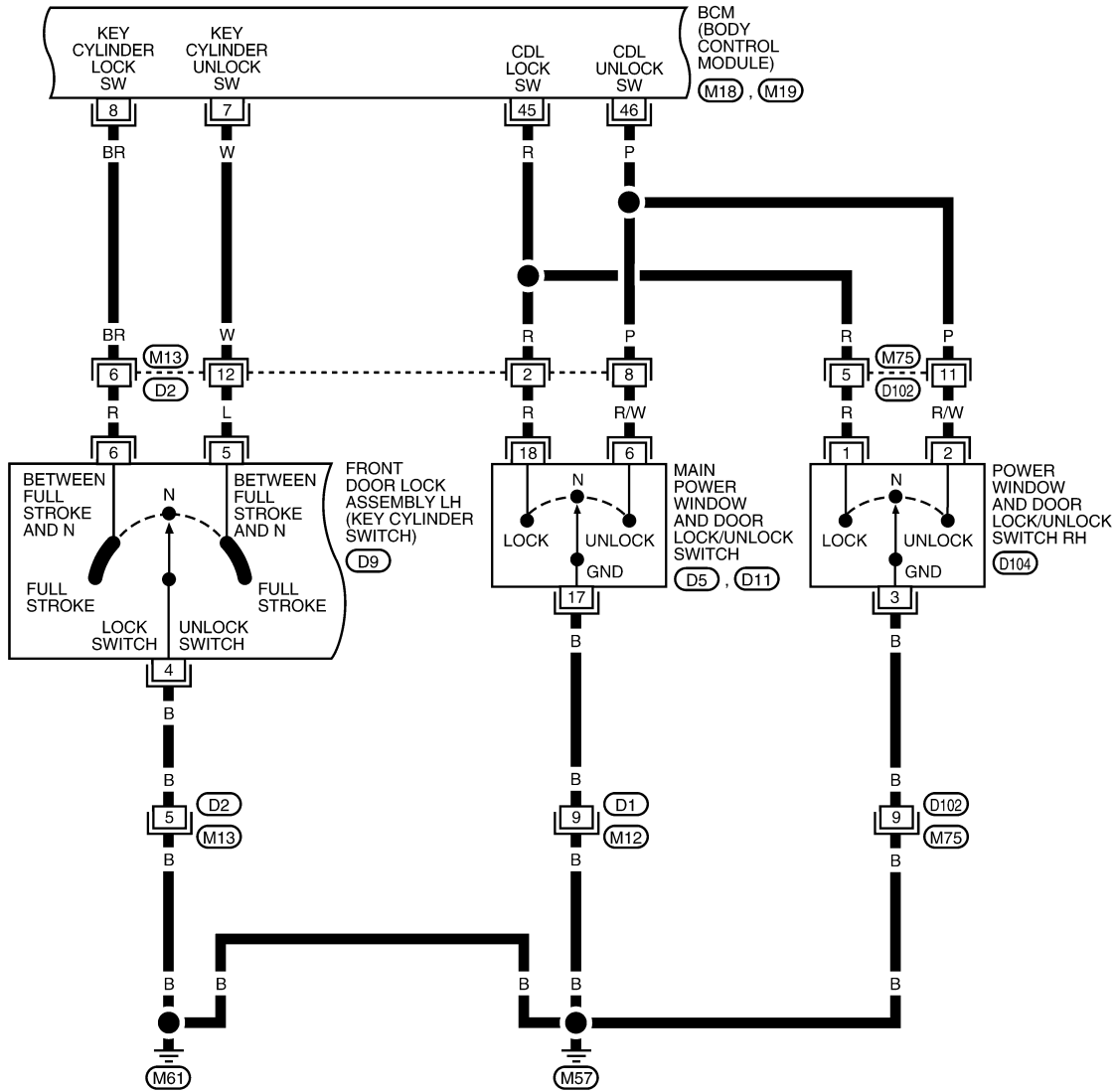

ABKWA0325GE

# POWER DOOR LOCK SYSTEM

< SERVICE INFORMATION >

BL-D/LOCK-09

— : DATA LINE

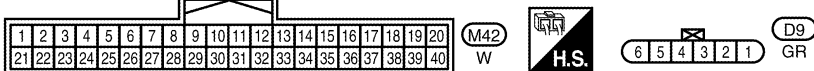
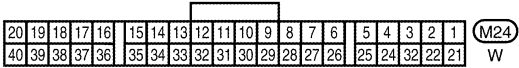
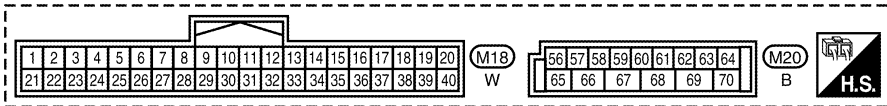
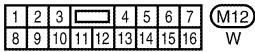
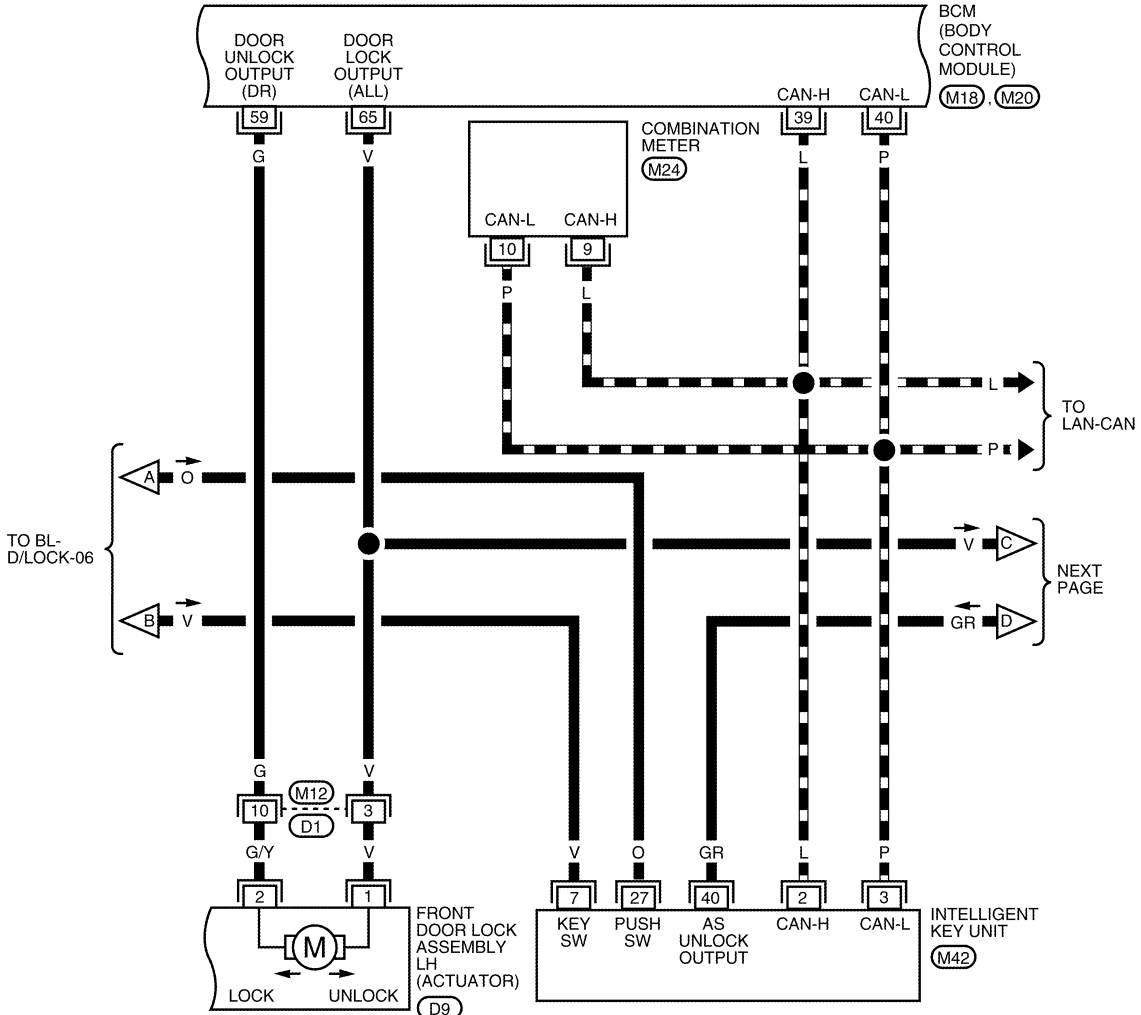

ABKWA0326GE

# POWER DOOR LOCK SYSTEM

< SERVICE INFORMATION >

BL-D/LOCK-10

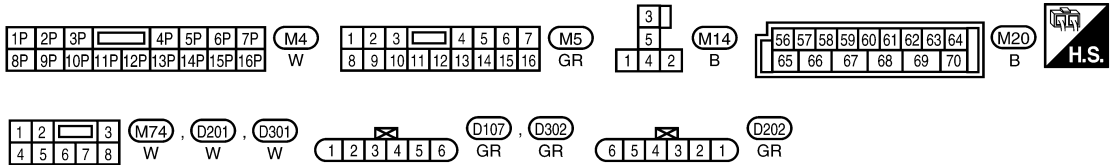
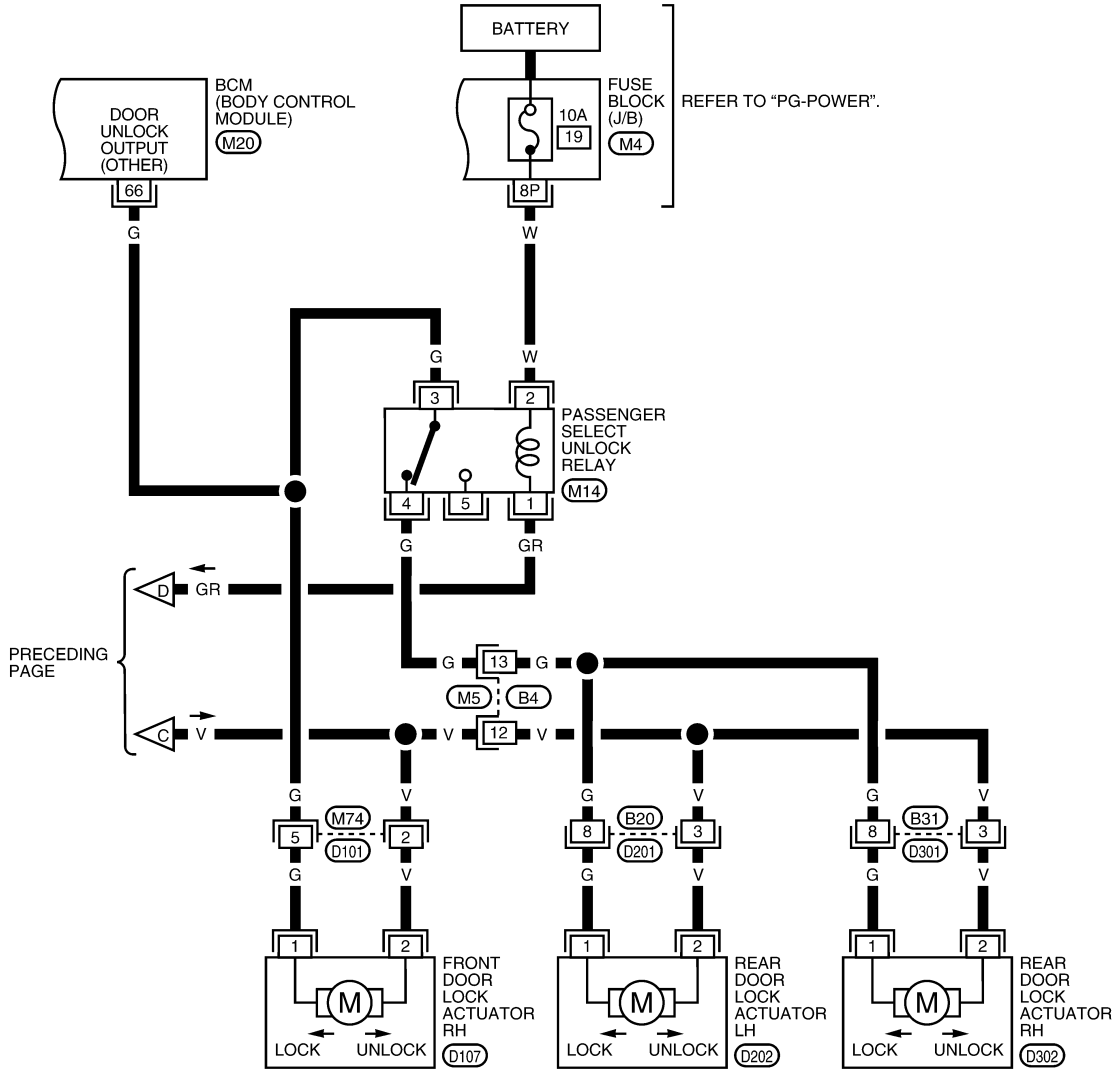

## Terminal and Reference Value for BCM

Refer to [BCS-11, "Terminal and Reference Value for BCM"](#).

## Work Flow

1. Check the symptom and customer's requests.
2. Understand the outline of system. Refer to [BL-20, "System Description"](#).

A  
B  
C  
D  
E  
F  
G  
H  
I  
J  
K  
L  
M  
N  
O



# POWER DOOR LOCK SYSTEM

## < SERVICE INFORMATION >

3. According to the trouble diagnosis chart, repair or replace the cause of the malfunction. Refer to [BL-37](#), "[Trouble Diagnosis Symptom Chart](#)".
4. Does power door lock system operate normally? OK: GO TO 5, NG: GO TO 3.
5. Inspection End.

## CONSULT-III Function (BCM)

INFOID:000000004407687

CONSULT-III can display each diagnostic item using the diagnostic test modes shown following.

BCM diagnostic test item	Diagnostic mode	Description
Inspection by part	WORK SUPPORT	Supports inspections and adjustments. Commands are transmitted to the BCM for setting the status suitable for required operation, input/output signals are received from the BCM and received date is displayed.
	DATA MONITOR	Displays BCM input/output data in real time.
	ACTIVE TEST	Operation of electrical loads can be checked by sending drive signal to them.
	SELF-DIAG RESULTS	Displays BCM self-diagnosis results.
	CAN DIAG SUPPORT MNTR	The result of transmit/receive diagnosis of CAN communication can be read.
	ECU PART NUMBER	BCM part number can be read.
	CONFIGURATION	Performs BCM configuration read/write functions.

## WORK SUPPORT

Work item	Description
DOOR LOCK-UNLOCK SET	Select unlock mode can be changed in this mode. Selects ON-OFF of select unlock mode.
ANTI-LOCK OUT SET	Key reminder door mode can be changed in this mode. Selects ON-OFF of key reminder door mode.
AUTOMATIC DOOR UN-LOCK SELECT	<ul style="list-style-type: none"> <li>• MODE1</li> <li>• MODE2</li> <li>• MODE3</li> <li>• MODE4</li> <li>• MODE5</li> <li>• MODE6</li> </ul>
AUTOMATIC LOCK/UNLOCK SELECT	<ul style="list-style-type: none"> <li>• ON</li> <li>• OFF</li> </ul>

## DATA MONITOR

Monitor item	Content
IGN ON SW	Indicates [ON/OFF] condition of ignition switch in ON position.
KEY ON SW	Indicates [ON/OFF] condition of key switch.
CDL LOCK SW	Indicates [ON/OFF] condition of lock signal from door lock and unlock switch.
CDL UNLOCK SW	Indicates [ON/OFF] condition of unlock signal from door lock and unlock switch.
DOOR SW-DR	Indicates [ON/OFF] condition of front door switch LH.
DOOR SW-AS	Indicates [ON/OFF] condition of front door switch RH.
DOOR SW-RR	Indicates [ON/OFF] condition of rear door switch RH.
DOOR SW-RL	Indicates [ON/OFF] condition of rear door switch LH.
KEY CYL LK-SW	Indicates [ON/OFF] condition of lock signal from key cylinder.
KEY CYL UN-SW	Indicates [ON/OFF] condition of unlock signal from key cylinder.
KEYLESS LOCK*	Indicates [ON/OFF] condition of lock signal from keyfob.
KEYLESS UNLOCK*	Indicates [ON/OFF] condition of unlock signal from keyfob.



# POWER DOOR LOCK SYSTEM

## < SERVICE INFORMATION >

Monitor item	Content
I-KEY LOCK**	Indicates [ON/OFF] condition of lock signal from door request switch.
I-KEY UNLOCK**	Indicates [ON/OFF] condition of unlock signal from door request switch.

\*: With Remote Keyless Entry system

\*\* : With Intelligent Key system

## ACTIVE TEST

Test item	Content
ALL LOCK	This test is able to check all door lock actuators lock operation. These actuators lock when "ON" on CONSULT-III screen is touched.
ALL UNLOCK	This test is able to check all door lock actuators unlock operation. These actuators unlock when "ON" on CONSULT-III screen is touched.
DR UNLOCK	This test is able to check front door lock actuator LH unlock operation. These actuators lock when "ON" on CONSULT-III screen is touched.
OTHER UNLOCK	This test is able to check door lock actuators (except front door lock actuator LH) unlock operation. These actuators unlock when "ON" on CONSULT-III screen is touched.

## Trouble Diagnosis Symptom Chart

INFOID:000000004407688

Symptom	Repair order	Refer to page
Key reminder door function does not operate properly.	1. BCM power supply and ground circuit check	<a href="#">BCS-14</a>
	2. Door switch check	<a href="#">BL-38</a>
	3. Key switch (insert) check	<a href="#">BL-39</a>
	4. Replace BCM.	<a href="#">BCS-17</a>
Power door lock does not operate with door lock and unlock switch on main power window and door lock/unlock switch, power window and door lock/unlock switch RH or door lock/unlock switch LH.	1. Door lock/unlock switch check	<a href="#">BL-40</a>
	2. Replace BCM.	<a href="#">BCS-17</a>
One or both rear door lock actuators do not operate.	1. Passenger select unlock relay circuit check	<a href="#">BL-47</a>
Front door lock assembly LH (actuator) does not operate.	1. Front door lock assembly LH (actuator) check	<a href="#">BL-44</a>
Specific door lock actuator does not operate.	1. Door lock actuator check (Front RH, Rear LH/RH)	<a href="#">BL-45</a>
Power door lock does not operate with front door key cylinder switch operation.	1. Front door key cylinder switch check	<a href="#">BL-46</a>
	2. Replace BCM.	<a href="#">BCS-17</a>
All power door locks do not operate.	1. BCM power supply and ground circuit check	<a href="#">BCS-14</a>
	2. Door lock/unlock switch check	<a href="#">BL-40</a>
	3. Replace BCM.	<a href="#">BCS-17</a>
Vehicle speed sensing auto door LOCK operation does not operate.	1. Ensure automatic door lock/unlock function (lock operation) is enabled.	<a href="#">BL-36</a>
	2. Check combination meter vehicle speed signal.	<a href="#">DI-17</a>
	3. Check intermittent incident.	<a href="#">GI-22</a>
Ignition OFF interlock auto door UNLOCK function does not operate.	1. Ensure automatic door lock/unlock function (unlock operation) is enabled.	<a href="#">BL-36</a>
	2. Check BCM for DTCs.	<a href="#">BCS-3</a>
	3. Check intermittent incident.	<a href="#">GI-22</a>

## BCM Power Supply and Ground Circuit Inspection

INFOID:000000004407689

Refer to [BCS-14, "BCM Power Supply and Ground Circuit Inspection"](#).

# POWER DOOR LOCK SYSTEM

< SERVICE INFORMATION >

## Door Switch Check

INFOID:000000004407690

### 1. CHECK DOOR SWITCHES INPUT SIGNAL

 With CONSULT-III

Check door switches ("DOOR SW-DR", "DOOR SW-AS", "DOOR SW-RL", "DOOR SW-RR") in DATA MONITOR mode with CONSULT-III. Refer to [BL-36. "CONSULT-III Function \(BCM\)"](#).

- When any doors are open:

**DOOR SW-DR : ON**  
**DOOR SW-AS : ON**  
**DOOR SW-RL : ON**  
**DOOR SW-RR : ON**

- When any doors are closed:

**DOOR SW-DR : OFF**  
**DOOR SW-AS : OFF**  
**DOOR SW-RL : OFF**  
**DOOR SW-RR : OFF**

 Without CONSULT-III

Check voltage between BCM connector M18 or M19 terminals 12, 13, 47, 48 and ground.

Connector	Item	Terminals		Condition	Voltage (V) (Approx.)
		(+)	(-)		
M19	Front door switch LH	47	Ground	Open ↓ Closed	0 ↓ Battery voltage
	Rear door switch LH	48			
M18	Front door switch RH	12			
	Rear door switch RH	13			

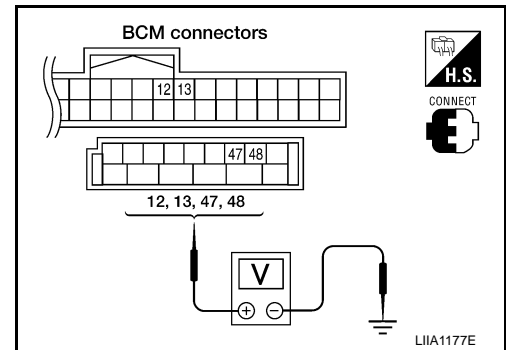

**OK or NG**

- OK >> Door switch circuit is OK.
- NG >> GO TO 2.

### 2. CHECK DOOR SWITCH CIRCUIT

- Turn ignition switch OFF.
- Disconnect door switch and BCM.
- Check continuity between door switch connector B21 (Front LH), B28 (Front RH), B26 (Rear LH), B41 (Rear RH) terminal 2 and BCM connector M18, M19 terminals 12, 13, 47 and 48.

**2 - 47 : Continuity should exist.**  
**2 - 12 : Continuity should exist.**  
**2 - 48 : Continuity should exist.**  
**2 - 13 : Continuity should exist.**

- Check continuity between door switch connector B21 (Front LH), B28 (Front RH), B26 (Rear LH), B41 (Rear RH) terminal 2 and ground.

**2 - Ground : Continuity should not exist.**

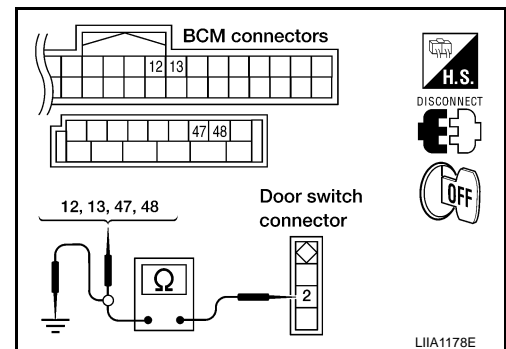

**OK or NG**

# POWER DOOR LOCK SYSTEM

## < SERVICE INFORMATION >

- OK >> GO TO 3.
- NG >> Repair or replace harness.

### 3.CHECK DOOR SWITCHES

Check continuity between door switch terminals.

Door switch (front or rear)	Terminals		Condition	Continuity
		2 - Ground	Pressed	No
	Released		Yes	

#### OK or NG

- OK >> GO TO 4.
- NG >> Replace door switch.

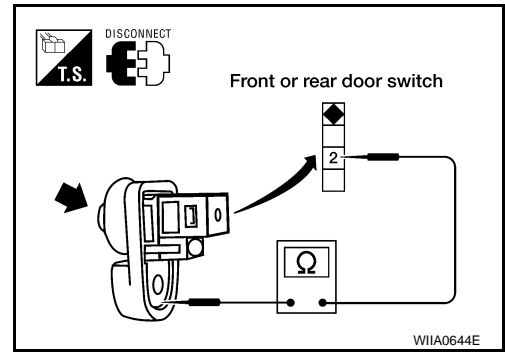

### 4.CHECK BCM OUTPUT VOLTAGE

1. Reconnect BCM connectors.
2. Check voltage between BCM connector M18, M19 terminals 12, 13, 47, 48 and ground.

- 12 - Ground : Battery voltage**
- 13 - Ground : Battery voltage**
- 47 - Ground : Battery voltage**
- 48 - Ground : Battery voltage**

#### OK or NG

- OK >> Door switch circuit is OK.
- NG >> Replace BCM. Refer to [BCS-17. "Removal and Installation of BCM"](#).

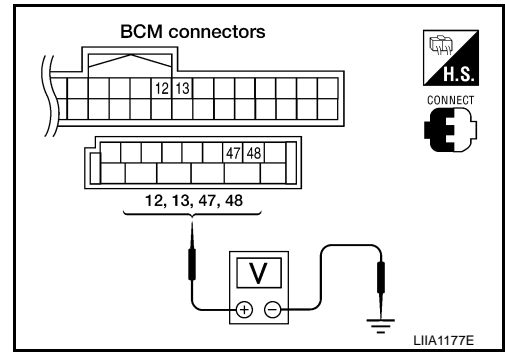

### Key Switch (Insert) Check

INFOID:000000004806048

#### 1.CHECK KEY SWITCH INPUT SIGNAL

##### With CONSULT-III

- Check key switch "KEY ON SW" in DATA MONITOR mode with CONSULT-III. Refer to XX-XX, "\*\*\*\*\*".
- When key is inserted into ignition key cylinder:

**KEY ON SW : ON**

- When key is removed from ignition key cylinder:

**KEY ON SW : OFF**

##### Without CONSULT-III

Check voltage between BCM connector and ground.

Connector	Terminals		Condition	Voltage (V) (Approx.)
	(+)	(-)		
M18	37	Ground	Key is inserted.	Battery voltage
			Key is removed.	0

#### OK or NG

- OK >> Key switch circuit is OK.
- NG-1 >> GO TO 2 (with Intelligent Key).
- NG-2 >> GO TO 3 (without Intelligent Key).

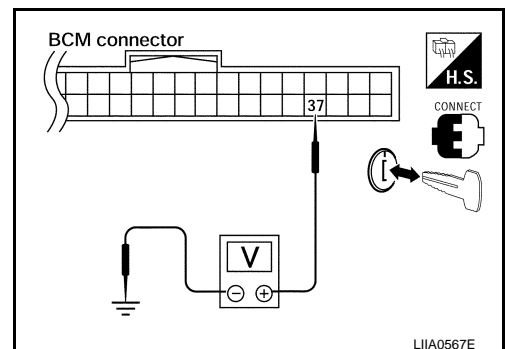

# POWER DOOR LOCK SYSTEM

## < SERVICE INFORMATION >

### 2. CHECK KEY SWITCH (WITH INTELLIGENT KEY)

1. Turn ignition switch OFF.
2. Disconnect key switch and ignition knob switch connector.
3. Check continuity between key switch and ignition knob switch terminals.

Terminal		Condition	Continuity
Key switch and ignition knob switch			
1	2	Key Inserted	Yes
		Key Removed	No

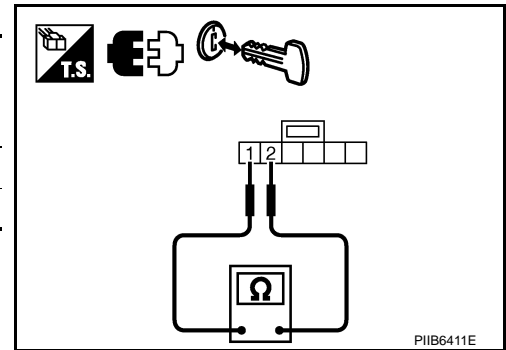

#### OK or NG

OK >> Check the following.

- 10A fuse (No. 9, located in fuse and fusible link block)
- Harness for open or short between key switch and ignition knob switch and fuse
- Harness for open or short between BCM and key switch and ignition knob switch

NG >> Replace key switch and ignition knob switch.

### 3. CHECK KEY SWITCH (WITHOUT INTELLIGENT KEY)

1. Turn ignition switch OFF.
2. Disconnect key switch connector.
3. Check key switch.

Terminals	Condition	Continuity
1 - 2	Key is inserted.	Yes
	Key is removed.	No

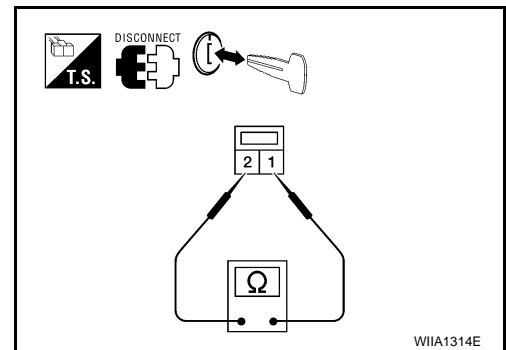

#### OK or NG

OK >> Check the following.

- 10A fuse [No. 19, located in fuse block (J/B)]
- Harness for open or short between key switch and fuse
- Harness for open or short between BCM and key switch

NG >> Replace key switch.

## Door Lock and Unlock Switch Check

INFOID:000000004407692

### 1. CHECK DOOR LOCK AND UNLOCK INPUT SIGNAL

#### Ⓟ With CONSULT-III

Check door lock and unlock switch ("CDL LOCK SW" and "CDL UNLOCK SW") in DATA MONITOR mode with CONSULT-III.

Test item	Condition
CDL LOCK SW	Door lock and unlock switch is turned to LOCK : ON
	Other than above : OFF
CDL UNLOCK SW	Door lock and unlock switch is turned to UNLOCK : ON
	Other than above : OFF

#### ⓧ Without CONSULT-III

Check voltage between BCM connector and ground

# POWER DOOR LOCK SYSTEM

## < SERVICE INFORMATION >

Terminals		Door lock and unlock switch condition	Voltage (V) (Approx.)
(+)	(-)		
BCM connector	Terminal		
M19	45	Lock	0
		Neutral / Unlock	Battery voltage
	46	Unlock	0
		Neutral / Lock	Battery voltage

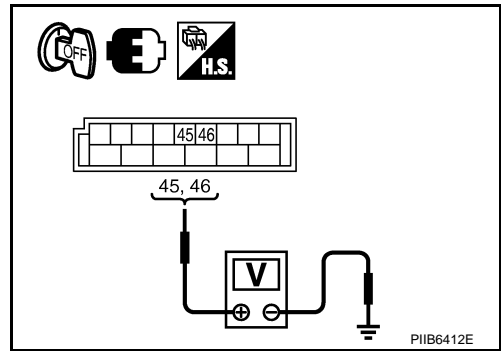

### OK or NG

- OK >> Door lock and unlock switch is OK.
- NG1 >> With power windows, GO TO 2.
- NG2 >> Without power windows, GO TO 5.

## 2. CHECK DOOR LOCK/UNLOCK SWITCH

1. Turn ignition switch OFF.
2. Disconnect door lock/unlock switch.
3. Check continuity between main power window and door lock/unlock switch connector D11 (B) terminal 18 and connector D11 (B) terminal 17, and connector D5 (A) terminal 6 and connector D11 (B) terminal 17.

Terminals	Condition	Continuity
18	Lock	Yes
	Unlock/Neutral	No
6	Unlock	Yes
	Lock/Neutral	No

4. Check continuity between power window and door lock/unlock switch RH connector D104 (C) terminals 1, 2 and 3.

Terminals	Condition	Continuity
1	Lock	Yes
	Unlock/Neutral	No
2	Unlock	Yes
	Lock/Neutral	No

### OK or NG

- OK >> GO TO 3.
- NG >> Replace door lock/unlock switch.

## 3. CHECK DOOR LOCK/UNLOCK SWITCH GROUND HARNESS

1. Disconnect main power window and door lock/unlock switch or power window and door lock/unlock switch RH.
2. Check continuity between main power window and door lock/unlock switch connector D11 terminal 17 and ground.

**17 - Ground : Continuity should exist.**

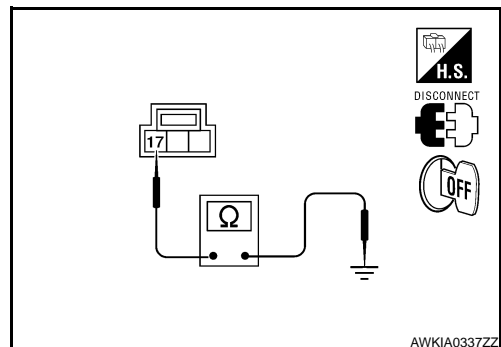
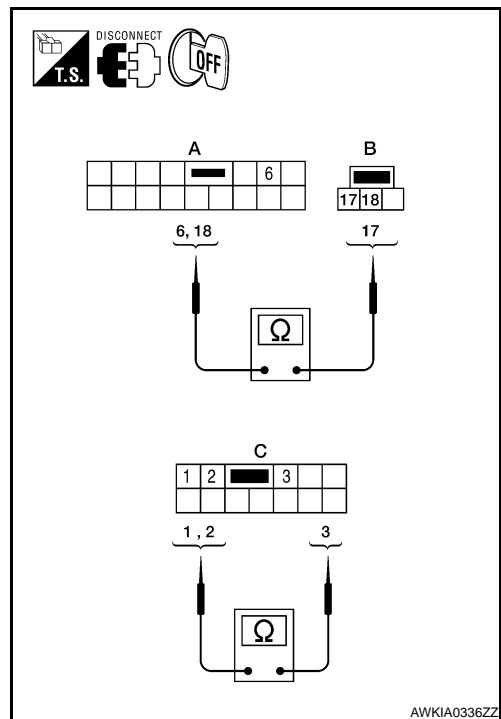

# POWER DOOR LOCK SYSTEM

## < SERVICE INFORMATION >

3. Check continuity between power window and door lock/unlock switch RH connector D104 terminal 3 and ground

**3 - Ground : Continuity should exist.**

### OK or NG

- OK >> GO TO 4.  
NG >> Repair or replace harness.

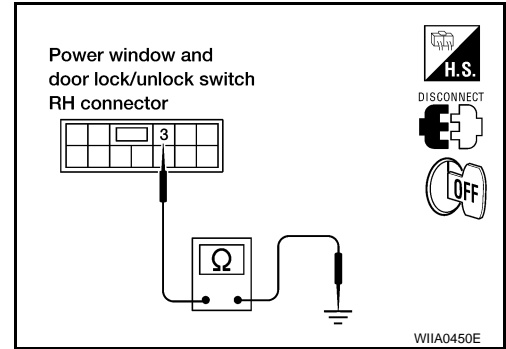

## 4. CHECK DOOR LOCK SWITCH CIRCUIT

1. Disconnect BCM.
2. Check continuity between BCM connector M19 (A) terminal 45 and main power window and door lock/unlock switch connector D11 (B) terminal 18 or power window and door lock/unlock switch RH connector D104 (C) terminal 1.

**1 - 45 : Continuity should exist.**

**18 - 45 : Continuity should exist.**

3. Check continuity between BCM connector M19 (A) terminal 45 and ground.

**45 - Ground : Continuity should not exist.**

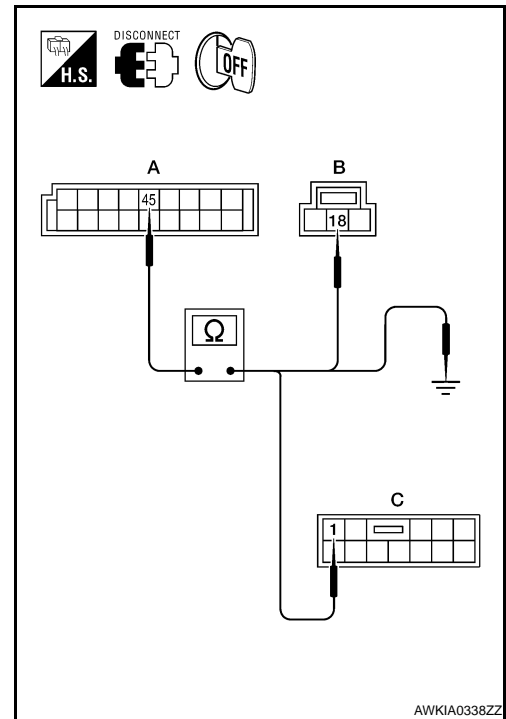

4. Check continuity between BCM connector M19 (A) terminal 46 and main power window and door lock/unlock switch LH connector D5 (B) terminal 6 or power window and door lock/unlock switch RH connector D104 (C) terminal 2.

# POWER DOOR LOCK SYSTEM

## < SERVICE INFORMATION >

- 2 - 46** : Continuity should exist.
- 6 - 46** : Continuity should exist.

5. Check continuity between BCM connector M19 (A) terminal 46 and ground.

- 46 - Ground** : Continuity should not exist.

### OK or NG

- OK >> Replace BCM. Refer to [BCS-17, "Removal and Installation of BCM"](#).
- NG >> Repair or replace harness.

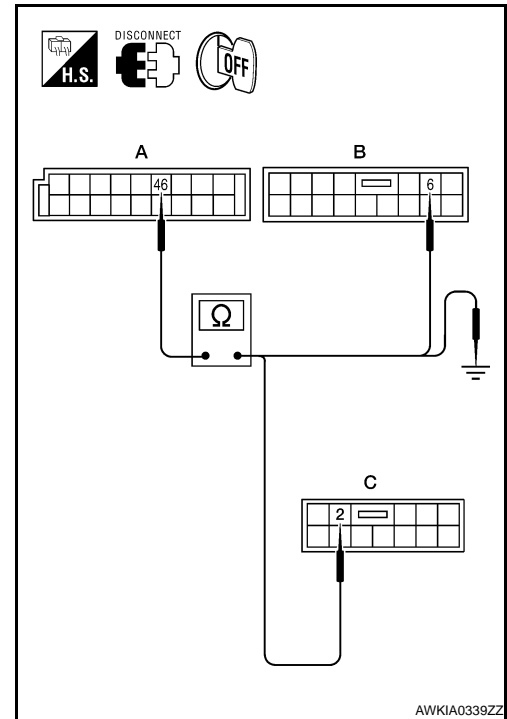

## 5. CHECK DOOR LOCK/UNLOCK SWITCH LH

1. Turn ignition switch OFF.
2. Disconnect door lock/unlock switch LH.
3. Check continuity between door lock/unlock switch LH terminals 1, 2 and 5.

Terminals	Condition	Continuity
1	Lock	Yes
	Unlock/Neutral	No
2	Unlock	Yes
	Lock/Neutral	No

### OK or NG

- OK >> GO TO 6.
- NG >> Replace door lock/unlock switch LH.

## 6. CHECK DOOR LOCK/UNLOCK SWITCH GROUND HARNESS

Check continuity between door lock/unlock switch connector D6 terminal 5 and ground.

- 5 - Ground** : Continuity should exist.

### OK or NG

- OK >> GO TO 7.
- NG >> Repair or replace harness.

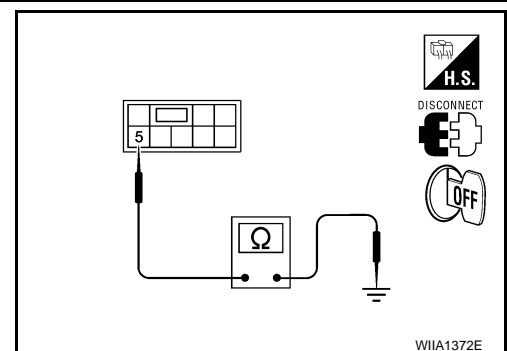
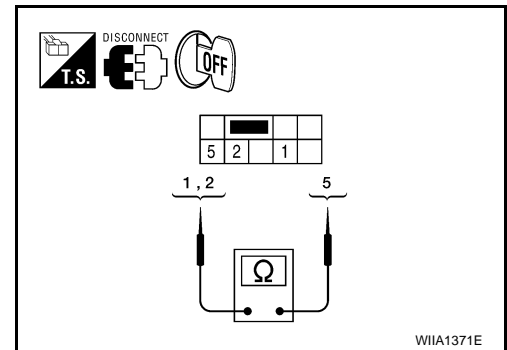

## 7. CHECK DOOR LOCK SWITCH CIRCUIT

1. Disconnect BCM.
2. Check continuity between BCM connector M19 (A) terminal 45 and door lock/unlock switch LH connector D6 (B) terminal 1.

# POWER DOOR LOCK SYSTEM

## < SERVICE INFORMATION >

**1 - 45 : Continuity should exist.**

3. Check continuity between BCM connector M19 (A) terminal 45 and ground.

**45 - Ground : Continuity should not exist.**

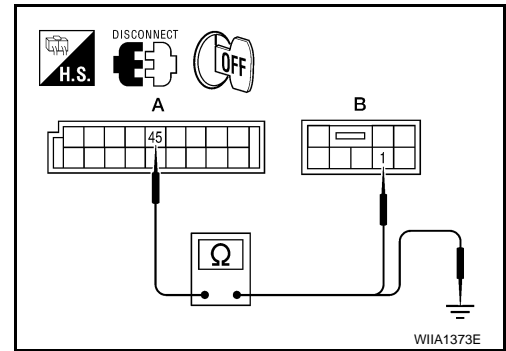

4. Check continuity between BCM connector M19 (A) terminal 46 and door lock/unlock switch LH connector D6 (B) terminal 2.

**2 - 46 : Continuity should exist.**

5. Check continuity between BCM connector M19 (A) terminal 46 and ground.

**46 - Ground : Continuity should not exist.**

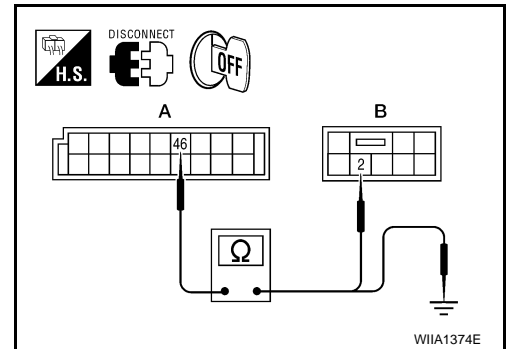

### OK or NG

- OK >> Replace BCM. Refer to [BCS-17. "Removal and Installation of BCM"](#).
- NG >> Repair or replace harness.

## Front Door Lock Assembly LH (Actuator) Check

INFOID:000000004407693

### 1. CHECK FRONT DOOR LOCK ASSEMBLY LH (ACTUATOR) HARNESS

1. Turn ignition switch OFF.
2. Disconnect BCM and front door lock assembly LH (actuator).
3. Check continuity between BCM connector M20 (A) terminals 59, 65 and front door lock assembly LH (actuator) connector D9 (B) terminals 1, 2.

Connector	Terminal	Connector	Terminal	Continuity
A: M20	59	B: D9	2	Yes
	65		1	Yes

4. Check continuity between BCM connector M20 (A) terminals 59, 65 and body ground.

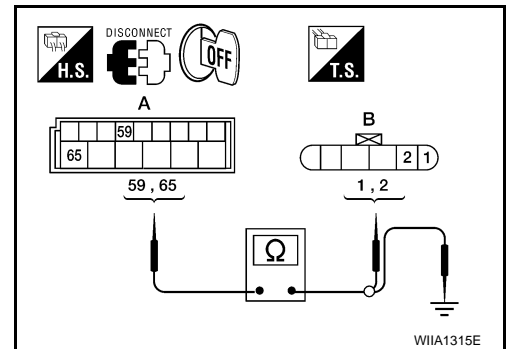

Connector	Terminals	Continuity
A: M20	59	No
	65	No

### OK or NG

- OK >> GO TO 2.
- NG >> Repair or replace harness.

### 2. CHECK FRONT DOOR LOCK ASSEMBLY LH SIGNAL

1. Reconnect BCM.



# POWER DOOR LOCK SYSTEM

## < SERVICE INFORMATION >

- Check voltage between BCM connector M20 terminals 59, 65 and ground.

Connector	Terminals		Condition	Voltage (V) (Approx.)
	(+)	(-)		
M20	59	Ground	Main power window and door lock/unlock switch is turned to UNLOCK	0 → Battery voltage
	65		Main power window and door lock/unlock switch is turned to LOCK	0 → Battery voltage

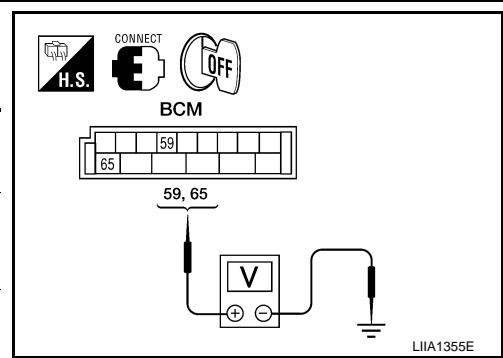

### OK or NG

- OK >> Replace front door lock assembly LH (actuator). Refer to [BL-135, "Removal and Installation"](#).
- NG >> Replace BCM. Refer to [BCS-17, "Removal and Installation of BCM"](#).

## Door Lock Actuator Check (Front RH and Rear LH/RH)

INFOID:000000004407694

### 1. CHECK DOOR LOCK ACTUATOR HARNESS

#### NOTE:

For models with Intelligent Key, insure that passenger select unlock relay remains connected during this test.

- Turn ignition switch OFF.
- Disconnect BCM and each door lock actuator.
- Check continuity between BCM connector M20 (A) terminals 65, 66 and front door lock actuator RH connector D107 (B), rear door lock actuator RH connector D302 (B), rear door lock actuator LH connector D202 (C) terminals 1, 2.

Connector	Terminal	Connector	Terminal	Continuity
A: M20	65	B: D107 C: D202 B: D302	2	Yes
	66		1	Yes

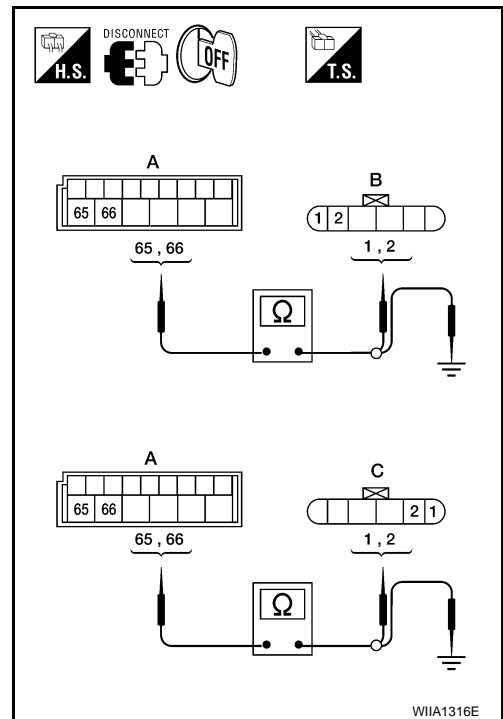

- Check continuity between BCM connector M20 (A) terminals 65, 66 and body ground.

Connector	Terminals	Continuity
A: M20	65	No
	66	No

### OK or NG

# POWER DOOR LOCK SYSTEM

## < SERVICE INFORMATION >

- OK >> GO TO 2.  
 NG >> Check the following:
- Without Intelligent Key: Repair or replace harness.
  - With Intelligent Key: For front doors, repair or replace harness.
  - With Intelligent Key: For rear door, repair or replace harness or passenger select unlock relay.

## 2.CHECK DOOR LOCK ACTUATOR SIGNAL

1. Reconnect BCM.
2. Check voltage between BCM connector M20 terminals 65, 66 and ground.

Connector	Terminals		Condition	Voltage (V) (Approx.)
	(+)	(-)		
M20	65	Ground	Main power window and door lock/unlock switch is turned to UNLOCK	0 → Battery voltage
	66		Main power window and door lock/unlock switch is turned to LOCK	0 → Battery voltage

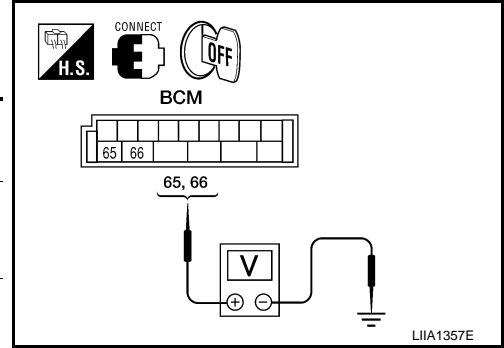

### OK or NG

- OK >> Replace front door lock assembly RH or rear door lock actuator LH/RH. Refer to [BL-135, "Removal and Installation"](#) (rear) or [BL-138, "Removal and Installation"](#) (rear).  
 NG >> Replace BCM. Refer to [BCS-17, "Removal and Installation of BCM"](#).

## Front Door Key Cylinder Switch LH Check

INFOID:000000004407695

## 1.CHECK FRONT DOOR KEY CYLINDER SWITCH LH

### Ⓟ With CONSULT-III

Check front door key cylinder switch ("KEY CYL LK-SW") and ("KEY CYL UN-SW") in DATA MONITOR mode in CONSULT-III. Refer to [BL-36, "CONSULT-III Function \(BCM\)"](#).

- When key inserted and front key cylinder is turned to LOCK:

**KEY CYL LK-SW : ON**

- When key inserted and front key cylinder is turned to UNLOCK:

**KEY CYL UN-SW : ON**

### ⓧ Without CONSULT-III

Check voltage between BCM connector M18 terminals 7, 8 and ground.

Connector	Terminals		Condition	Voltage (V) (Approx.)
	(+)	(-)		
M18	7	Ground	Neutral/Lock	5
			Unlock	0
	8		Neutral/Unlock	5
			Lock	0

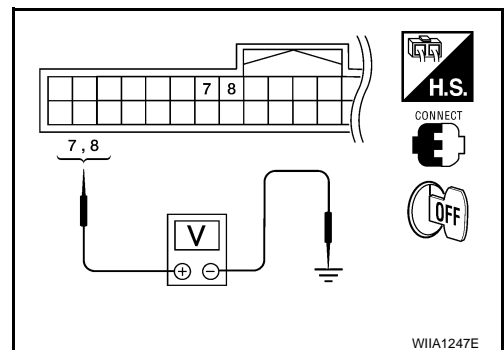

### OK or NG

- OK >> Front door key cylinder switch LH signal is OK.  
 NG >> GO TO 2.

## 2.CHECK FRONT DOOR KEY CYLINDER SWITCH LH GROUND HARNESS

# POWER DOOR LOCK SYSTEM

## < SERVICE INFORMATION >

1. Turn ignition switch OFF.
2. Disconnect front door key cylinder switch LH.
3. Check continuity between front door key cylinder switch LH connector D9 terminal 4 and body ground.

Connector	Terminals	Continuity
D9	4 – Ground	Yes

### OK or NG

- OK >> GO TO 3.  
 NG >> Repair or replace harness.

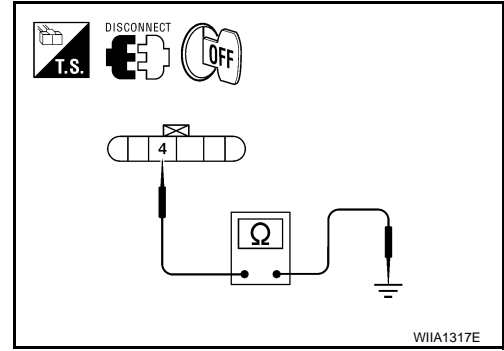

## 3.CHECK DOOR KEY CYLINDER SWITCH LH

Check continuity between front door key cylinder switch LH terminals.

Terminals	Door key cylinder switch position	Continuity
4 – 6	Neutral/Unlock	No
	Lock	Yes
4 – 5	Neutral/Lock	No
	Unlock	Yes

### OK or NG

- OK >> GO TO 4.  
 NG >> Replace front door key cylinder switch LH. Refer to [BL-135](#).

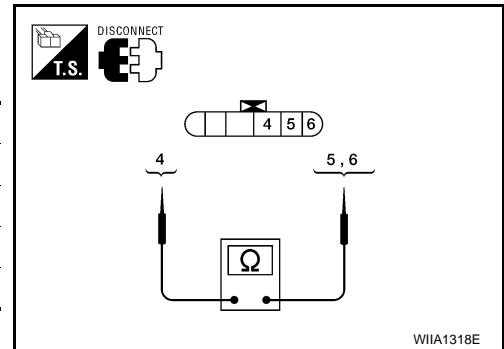

## 4.CHECK DOOR KEY CYLINDER HARNESS

1. Disconnect BCM connector M18.
2. Check continuity between BCM connector M18 (A) terminals 7, 8 and front door key cylinder switch LH connector D9 (B) terminals 5, 6 and body ground.

Connector	Terminal	Connector	Terminal	Continuity
A: M18	7	B: D9	5	Yes
	8		6	Yes
	7	Ground	No	
	8	Ground	No	

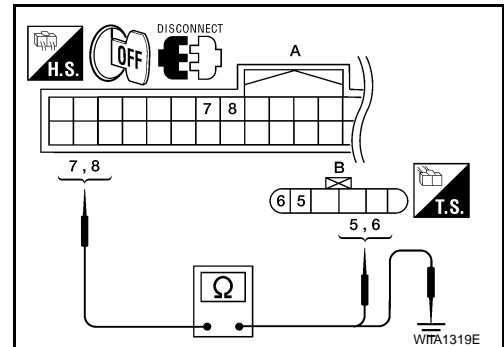

### OK or NG

- OK >> Front door key cylinder switch LH circuit is OK.  
 NG >> Repair or replace harness.

## Passenger Select Unlock Relay Circuit Inspection (With Intelligent Key)

INFOID:000000004407696

### 1.CHECK PASSENGER SELECT UNLOCK RELAY CIRCUIT

#### NOTE:

Passenger select unlock relay must remain connected during this step.

1. Turn ignition switch OFF.
2. Disconnect BCM and inoperative rear door lock actuator.

# POWER DOOR LOCK SYSTEM

## < SERVICE INFORMATION >

- Check continuity between BCM connector M20 (A) terminal 65 and rear door lock actuator LH connector D202 (B) terminal 2 or rear door lock actuator RH connector D302 (C) Terminal 2.

**65 - 2 : Continuity should exist.**

- Check continuity between BCM connector M20 (A) terminal 65 and body ground.

**65 - Ground : Continuity should not exist.**

### OK or NG

- OK >> GO TO 4.
- NG >> GO TO 2.

## 2. CHECK PASSENGER SELECT UNLOCK RELAY INPUT

- Disconnect passenger select unlock relay.
- Check continuity between BCM connector M20 (A) terminal 66 and passenger select unlock relay connector M14 (B) terminal 3.

**66 - 3 : Continuity should exist.**

- Check continuity between BCM connector M20 (A) terminal 66 and body ground.

**66 - Ground : Continuity should not exist.**

### OK or NG

- OK >> GO TO 3.
- NG >> Repair or replace harness between BCM and relay.

## 3. CHECK PASSENGER SELECT UNLOCK RELAY OUTPUT

- Disconnect inoperative rear door lock actuator.
- Check continuity between passenger select unlock relay connector M14 (A) terminal 4 and rear door lock actuator LH connector D202 (B) or rear door lock actuator RH connector D302 (C) terminal 1.

**4 - 1 : Continuity should exist.**

- Check continuity between passenger select unlock relay connector M14 (A) terminal 4 and ground.

**4 - Ground : Continuity should not exist.**

### OK or NG

- OK >> Replace passenger select unlock relay.
- NG >> Repair or replace harness between relay and actuator.

## 4. CHECK REAR DOOR LOCK ACTUATOR ASSEMBLY

- Reconnect BCM.

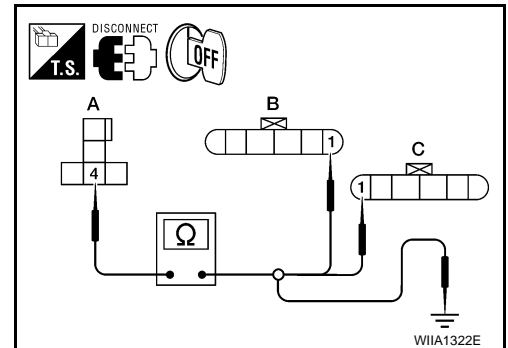
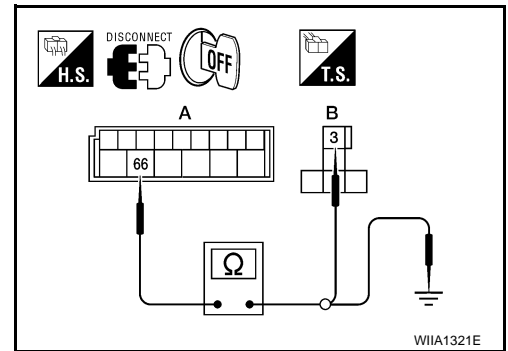
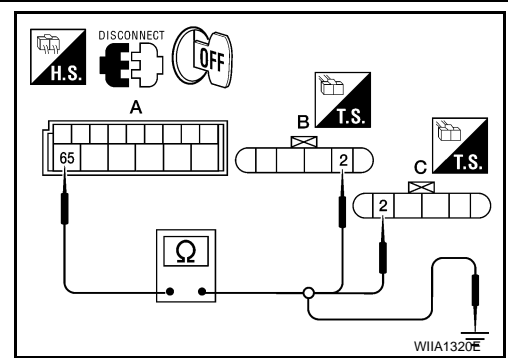

# POWER DOOR LOCK SYSTEM

## < SERVICE INFORMATION >

2. Check voltage between rear door lock actuator connector LH D202 (A) or rear door lock actuator connector RH D302 (B) terminals 1 and 2.

Connector	Terminals		Condition	Voltage (V) (Approx.)
	(+)	(-)		
A: D202 (LH) B: D302 (RH)	2	1	Main power window and door lock/unlock switch is turned to LOCK	0 → Battery voltage

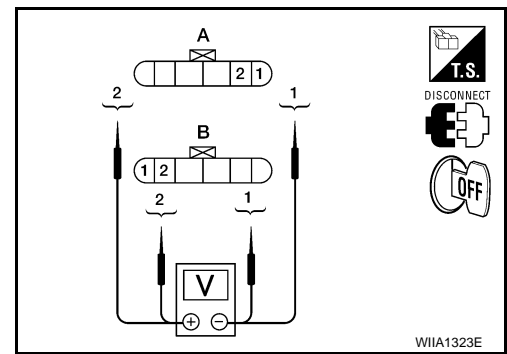

3. Check voltage between rear door lock actuator connector LH D202 (A) or rear door lock actuator connector RH D302 (B) terminals 1 and 2.

Connector	Terminals		Condition	Voltage (V) (Approx.)
	(+)	(-)		
A: D202 (LH) B: D302 (RH)	1	2	Main power window and door lock/unlock switch is turned to UNLOCK	0 → Battery voltage

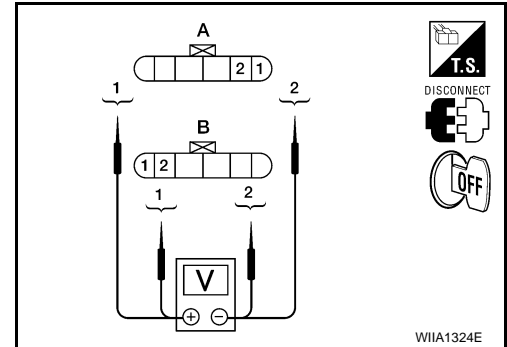

### OK or NG

- OK >> Replace rear door lock actuator. Refer to [BL-138. "Removal and Installation"](#).  
 NG >> Repair or replace harness between actuator and splice.

A  
B  
C  
D  
E  
F  
G  
H  
J  
K  
L  
M  
N  
O  
P

BL

# REMOTE KEYLESS ENTRY SYSTEM

< SERVICE INFORMATION >

## REMOTE KEYLESS ENTRY SYSTEM

### Component Parts and Harness Connector Location

INFOID:000000004407697

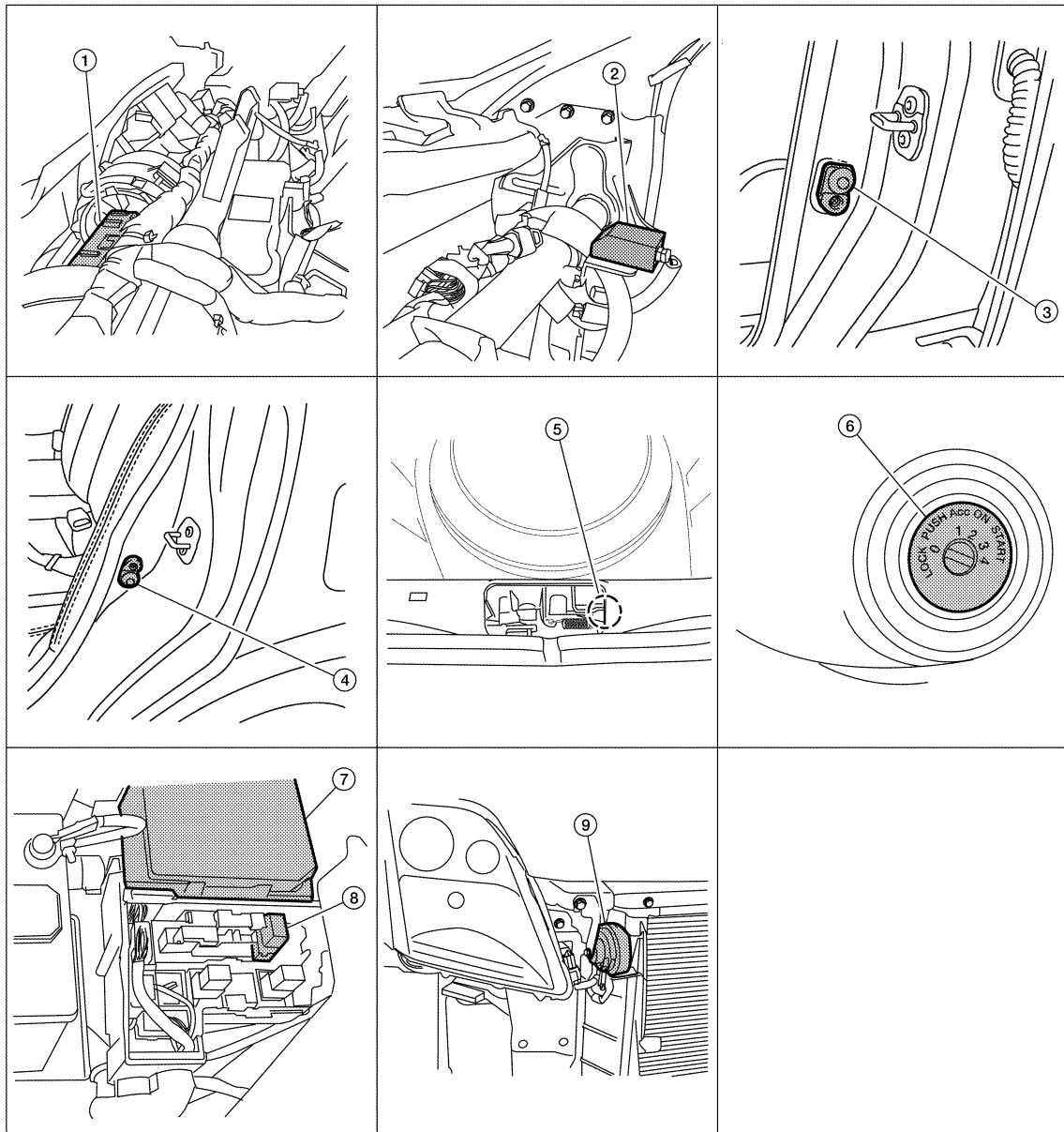

B1IA0004E

- |  |  |                                     |
|--|--|-------------------------------------|
| 1. BCM M18, M19, M20<br>(view with instrument panel removed) | 2. Remote keyless entry receiver M15<br>(view with instrument panel removed) | 3. Front door switch LH B21, RH B28 |
| 4. Rear door switch LH B26, RH B41                           | 5. Trunk room lamp switch B57  | 6. Key switch M50                   |
| 7. IPDM E/R E43, E46, E48<br>(next to battery)               | 8. Horn relay H-1<br>(front of battery)                                      | 9. Horn E57, E58                    |

### System Description

INFOID:000000004407698

#### INPUTS

Power is supplied at all times

- through 50A fusible link (letter j, located in the fuse and fusible link box)
- to BCM terminal 70
- through 10A fuse [No. 21, located in the fuse block (J/B)]
- to BCM terminal 57.

When the key switch is ON (key is inserted in ignition key cylinder), power is supplied

- through 10A fuse [No. 19, located in the fuse block (J/B)]

# REMOTE KEYLESS ENTRY SYSTEM

## < SERVICE INFORMATION >

- through key switch terminals 2 and 1
- to BCM terminal 37.

When the ignition switch is ACC or ON, power is supplied

- through 10A fuse [No. 6, located in the fuse block (J/B)]
- to BCM terminal 11.

When the ignition switch is ON or START, power is supplied

- through 10A fuse [No. 12, located in the fuse block (J/B)]
- to BCM terminal 38.

Ground is supplied

- to BCM terminal 67
- through body grounds M57 and M61.

When the front door switch LH is ON (door is OPEN), ground is supplied

- to BCM terminal 47
- through front door switch LH terminal 2
- through front door switch LH case ground.

When the front door switch RH is ON (door is OPEN), ground is supplied

- to BCM terminal 12
- through front door switch RH terminal 2
- through front door switch RH case ground.

When the rear door switch LH is ON (door is OPEN), ground is supplied

- to BCM terminal 48
- through rear door switch LH terminal 2
- through rear door switch LH case ground.

When the rear door switch RH is ON (door is OPEN), ground is supplied

- to BCM meter terminal 13
- through rear door switch RH terminal 2
- through rear door switch RH case ground.

When the trunk room lamp switch is ON (trunk is OPEN), ground is supplied

- to BCM terminal 42
- through trunk room lamp switch terminals 1 and 2
- through body grounds B7 and B19.

Keyfob signal is inputted to BCM from remote keyless entry receiver.

The remote keyless entry system controls operation of the

- power door lock
- hazard reminder
- auto door lock
- panic alarm
- room lamp

## OPERATION PROCEDURE

### Power Door Lock Operation

BCM receives a LOCK signal from keyfob. BCM locks all doors with input of LOCK signal from keyfob.

BCM receives an UNLOCK signal from keyfob. BCM unlocks all doors with input of UNLOCK signal from keyfob.

### Hazard and Horn Reminder

When the doors are locked or unlocked by keyfob, power is supplied to sound horn and flash hazard warning lamps as follows

- LOCK operation: 3 or 4 mode (lamps flash twice)
- UNLOCK operation: 2 or 4 mode (lamps flash once)
- Horns sound once with LOCK function when this feature is set ON.

The hazard reminder has modes 1, 2, 3 or 4. The horn reminder can be turned ON/OFF with any LOCK mode.

### Operating function of hazard reminder

	Mode 1		Mode 2		Mode 3		Mode 4	
	Lock	Unlock	Lock	Unlock	Lock	Unlock	Lock	Unlock
Hazard warning lamp flash	—	—	—	Once	Twice	—	Twice	Once
Horns sound (ON/OFF)	ON: once	—	ON: once	—	ON: once	—	ON: once	—

Hazard and horn reminders do not operate if any door switch is ON (any door is OPEN).

### How to change hazard and horn reminder modes

# REMOTE KEYLESS ENTRY SYSTEM

## < SERVICE INFORMATION >

---

### Ⓟ **With CONSULT-III**

Hazard reminder can be changed using "HAZARD LAMP SET" mode in "WORK SUPPORT".

Horn reminder can be changed using "HORN CHIRP SET" mode in "WORK SUPPORT".

Refer to [BL-57, "CONSULT-III Function \(BCM\)"](#).

### ⓧ **Without CONSULT-III**

Refer to Owner's Manual for instructions.

#### Auto Door Lock Operation

Auto lock function signal is sent for operation when any of the following signals are not sent within 1 minute after the unlock signal is sent from the keyfob:

- when door switch is turned ON for open
- when the key switch is turned ON
- when the lock signal is sent from the keyfob

Auto door lock mode can be changed using "AUTO LOCK SET" mode in "WORK SUPPORT".

Refer to [BL-57, "CONSULT-III Function \(BCM\)"](#).

#### Panic Alarm Operation

When key switch is OFF (when ignition key is not inserted in key cylinder), BCM turns on and off horn intermittently with input of PANIC ALARM signal from keyfob.

BCM outputs to IPDM E/R for panic alarm signal (horn signal) as DATA LINE (CAN H line and CAN L line).

The alarm automatically turns off after 25 seconds or when BCM receives any signal from keyfob.

Panic alarm operation mode can be changed using "PANIC ALARM SET" mode in "WORK SUPPORT".

Refer to [BL-57, "CONSULT-III Function \(BCM\)"](#).

#### Trunk Lid Operation

When a TRUNK OPEN signal is sent with key OFF (ignition key removed from key cylinder) from keyfob, power is supplied

- through BCM terminal 53
- to trunk lid opener actuator terminal 1.

When power and ground are supplied, trunk lid opener actuator opens trunk lid.

#### Interior Lamp Operation

When the following conditions occur, remote keyless entry system turns on interior lamp (for 30 seconds) with input of UNLOCK signal from keyfob. For detailed description, refer to [LT-83](#).

- Interior room lamp switch is in the DOOR position
- door switch OFF (when all the doors are closed)

## CAN Communication System Description

INFOID:000000004407699

Refer to [LAN-6, "System Description"](#).



# REMOTE KEYLESS ENTRY SYSTEM

< SERVICE INFORMATION >

## Schematic

INFOID:000000004407700

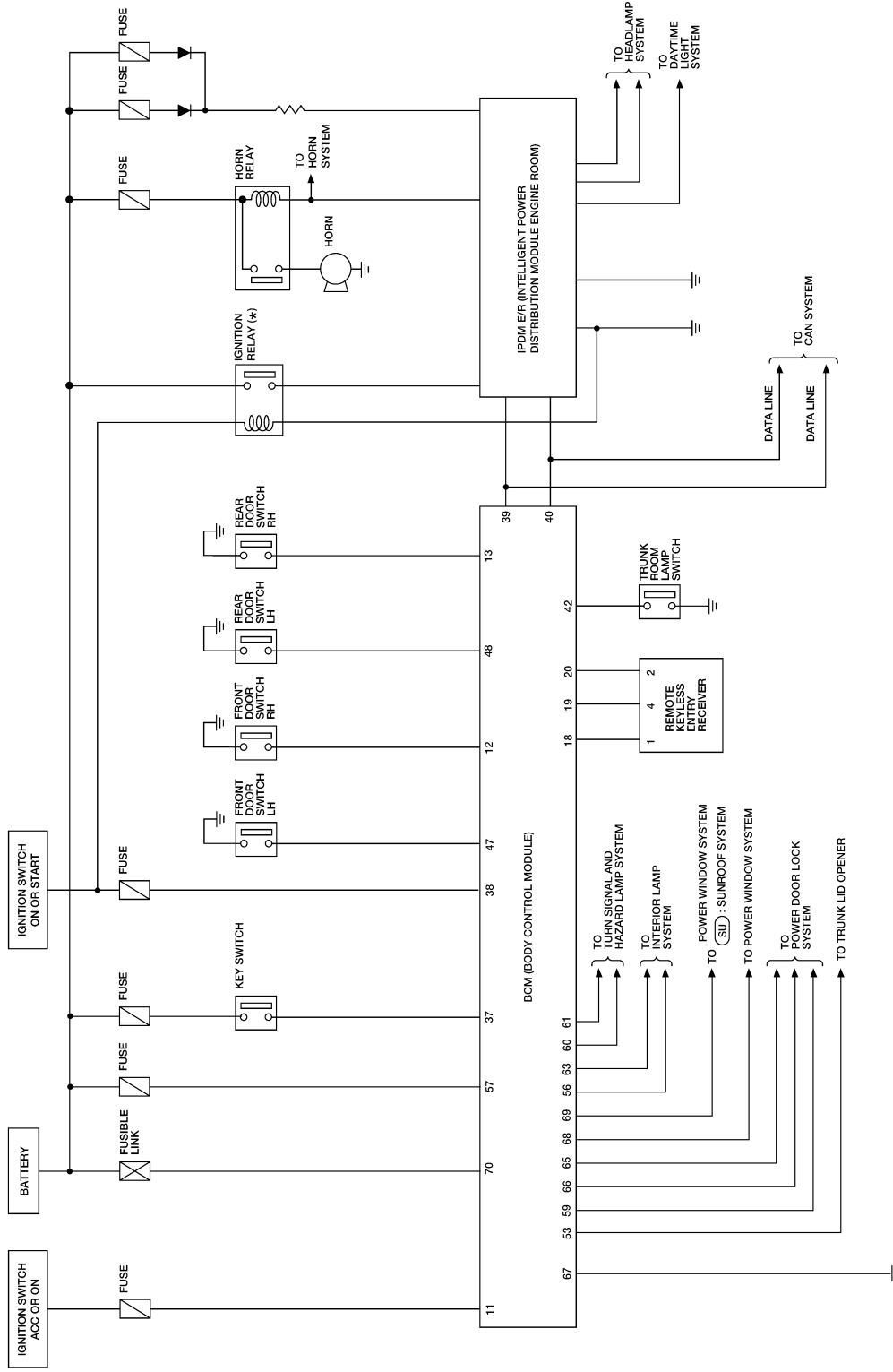

\*: THIS RELAY IS BUILT INTO THE IPDM E/R (INTELLIGENT POWER DISTRIBUTION MODULE ENGINE ROOM). (SU) : WITH SUNROOF

ABKWA0327GE

A  
B  
C  
D  
E  
F  
G  
H  
I  
J  
K  
L  
M  
N  
O  
P

BL

# REMOTE KEYLESS ENTRY SYSTEM

< SERVICE INFORMATION >

## Wiring Diagram - KEYLES -

INFOID:000000004407701

### BL-KEYLES-01

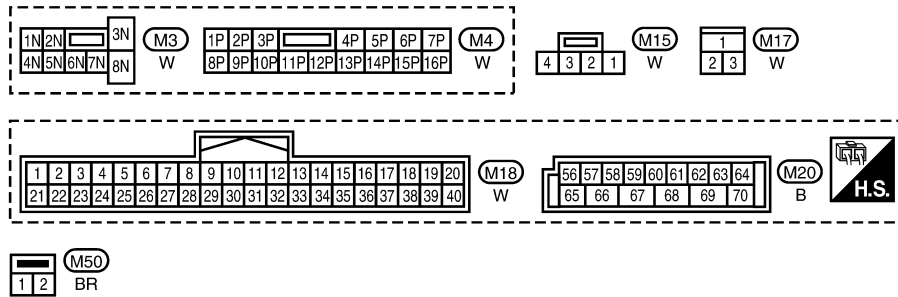
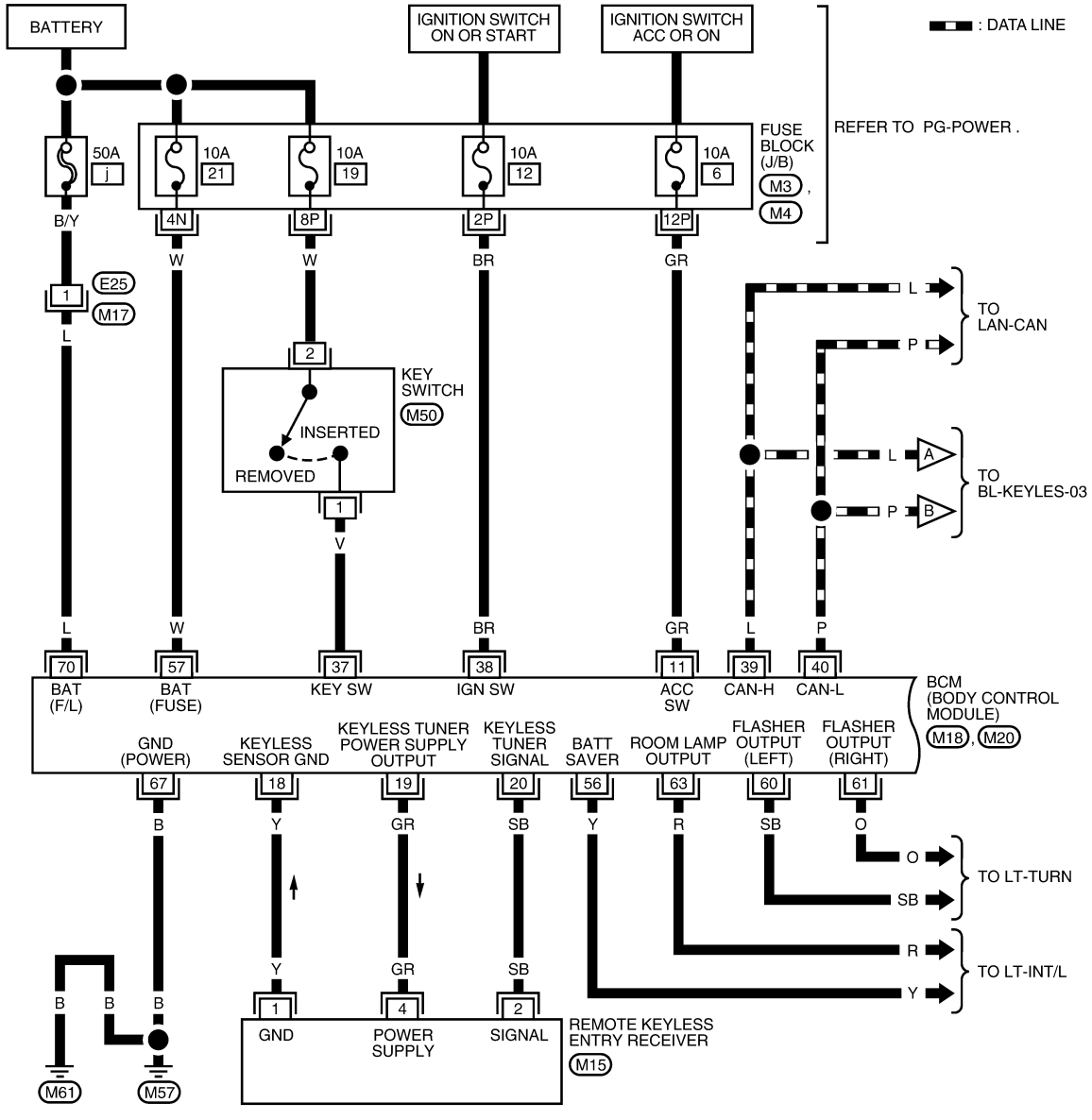

WIWA2187E

# REMOTE KEYLESS ENTRY SYSTEM

< SERVICE INFORMATION >

## BL-KEYLES-02

: WITH SUNROOF

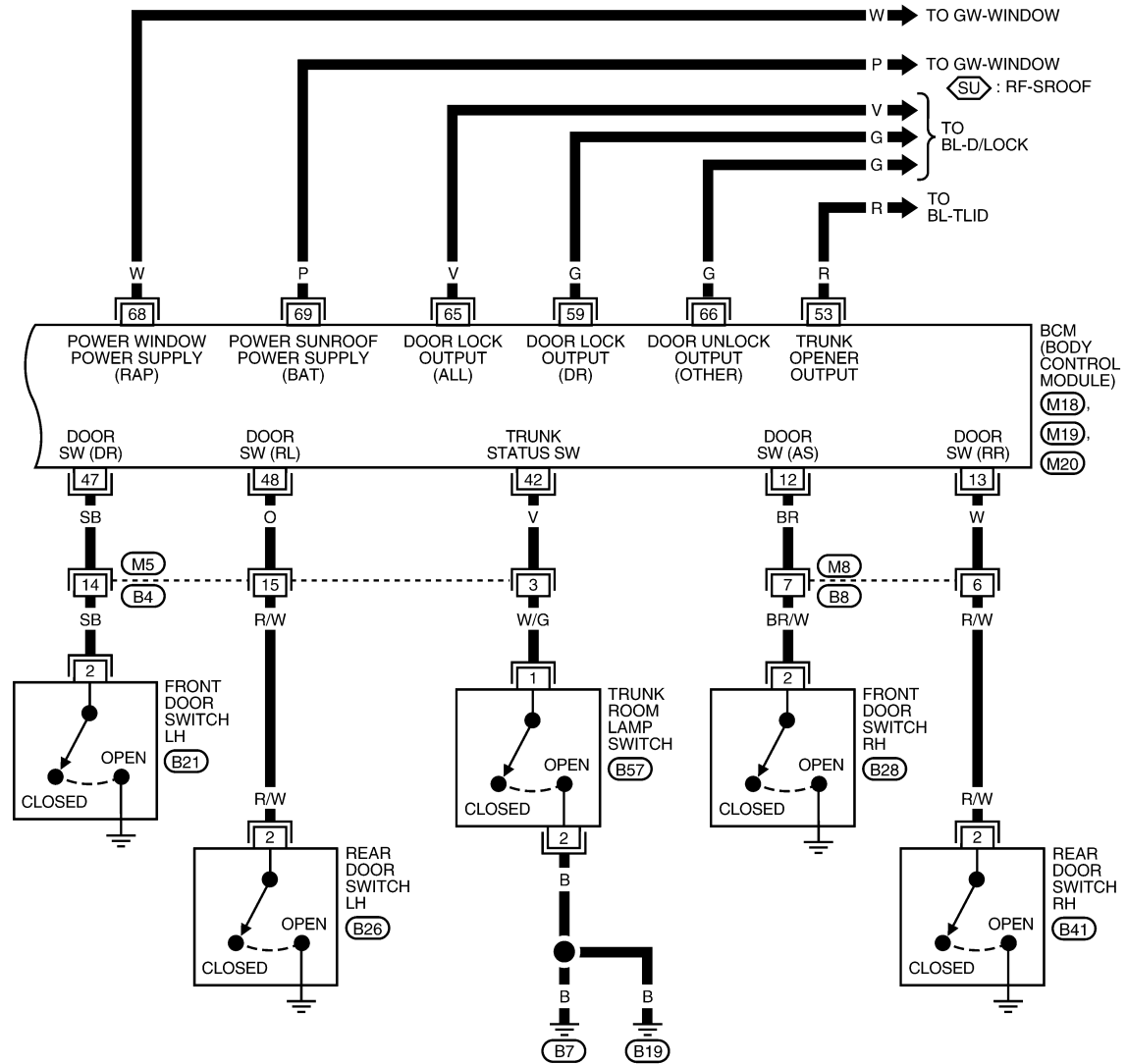

1	2	3	4	5	6	7	(M5)	(M8)		
8	9	10	11	12	13	14	15	16	GR	W

1	2	3	4	5	6	7	8	9	10	11	12	13	14	15	16	17	18	19	20	(M18)	41	42	43	44	45	46	47	48	49	(M19)	56	57	58	59	60	61	62	63	64	(M20)	65	66	67	68	69	70	
21	22	23	24	25	26	27	28	29	30	31	32	33	34	35	36	37	38	39	40	W	50	51	52	53	54	55	W	B																			

	1						
	2	(B21)	(B26)	(B28)	(B41)		(B57)
	3	W	W	W	W	2 1	W

ABKWA0328GE

# REMOTE KEYLESS ENTRY SYSTEM

< SERVICE INFORMATION >

BL-KEYLES-03

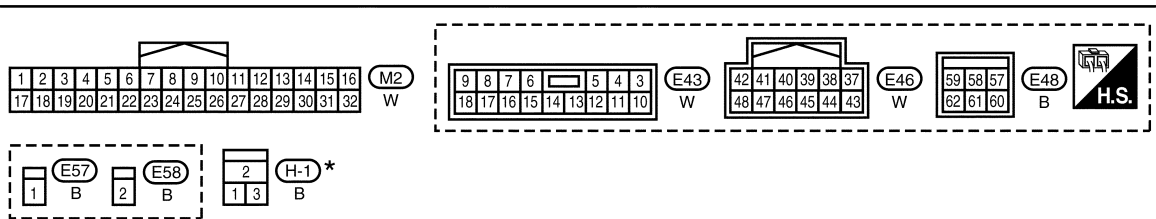
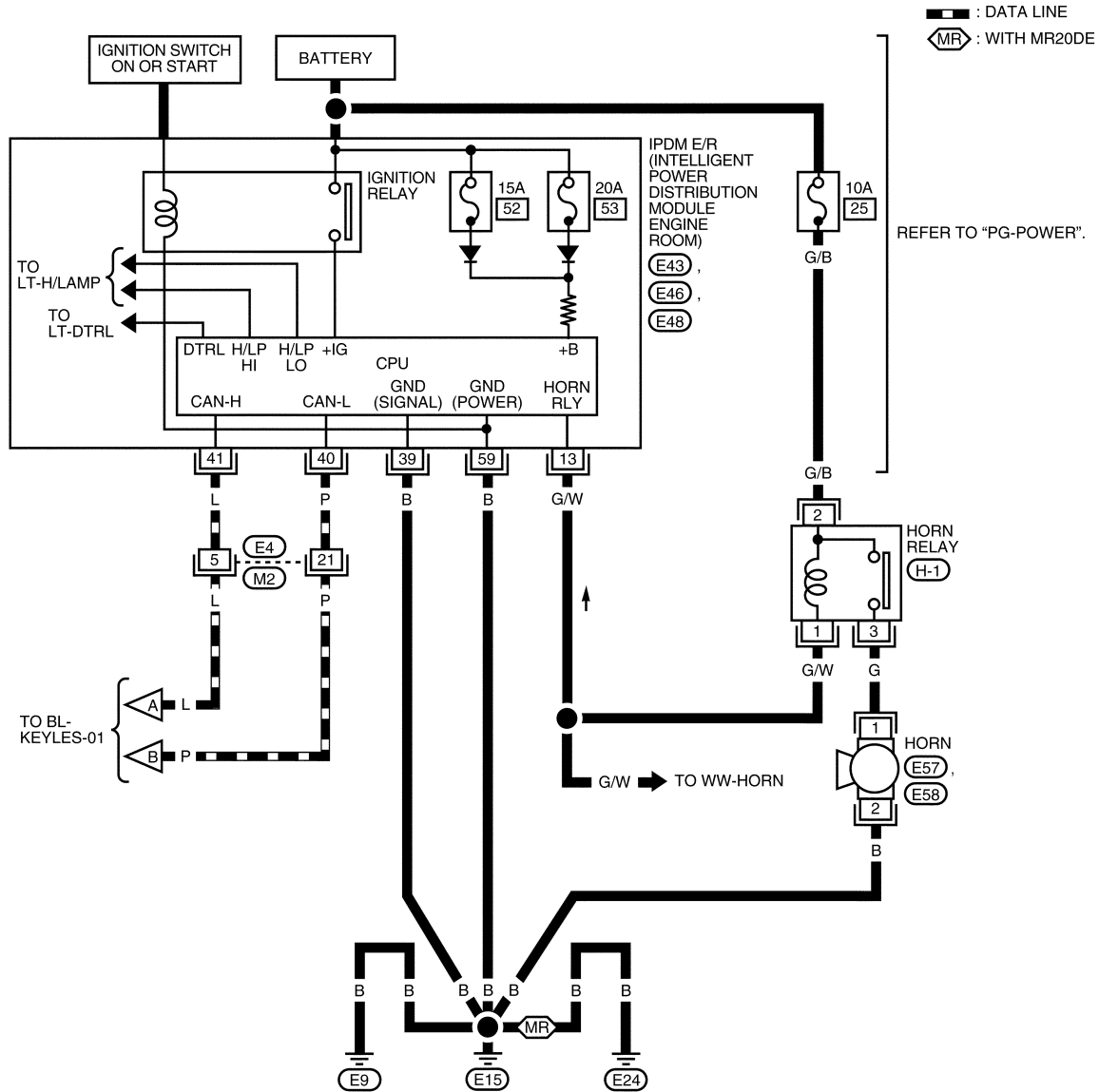

\*: THIS CONNECTOR IS NOT SHOWN IN "HARNESS LAYOUT" OF PG SECTION.

WIWA2323E

INFOID:000000004407702

## Terminal and Reference Value for BCM

Refer to [BCS-11, "Terminal and Reference Value for BCM"](#).

## How to Perform Trouble Diagnosis

INFOID:000000004407703

1. Confirm the symptom or customer complaint.
2. Understand operation, description and function description. Refer to [BL-50, "System Description"](#).

# REMOTE KEYLESS ENTRY SYSTEM

## < SERVICE INFORMATION >

3. Perform the Preliminary Check. Refer to [BL-58. "Work Flow"](#).
4. Check symptom and repair or replace the component.
5. Does the remote keyless entry system operate normally? If YES, GO TO 6. If NO, GO TO 4.
6. Inspection end.

## CONSULT-III Function (BCM)

INFOID:000000004407704

CONSULT-III can display each diagnostic item using the diagnostic test modes shown following.

BCM diagnostic test item	Diagnostic mode	Description
Inspection by part	WORK SUPPORT	Supports inspections and adjustments. Commands are transmitted to the BCM for setting the status suitable for required operation, input/output signals are received from the BCM and received date is displayed.
	DATA MONITOR	Displays BCM input/output data in real time.
	ACTIVE TEST	Operation of electrical loads can be checked by sending drive signal to them.
	SELF-DIAG RESULTS	Displays BCM self-diagnosis results.
	CAN DIAG SUPPORT MNTR	The result of transmit/receive diagnosis of CAN communication can be read.
	ECU PART NUMBER	BCM part number can be read.
	CONFIGURATION	Performs BCM configuration read/write functions.

## CONSULT-III APPLICATION ITEMS

### Work Support

Test Item	Description
REMO CONT ID REGIST	Keyfob ID code can be registered.
REMO CONT ID ERASER	Keyfob ID code can be erased.
REMO CONT ID CONFIR	It can be checked whether keyfob ID code is registered or not in this mode.
HAZARD LAMP SET	Hazard reminder mode can be changed in this mode. The hazard reminder mode will be changed when "CURRENT SETTING" on CONSULT-III screen is touched.
AUTO LOCK SET	Auto locking function mode can be changed in this mode. The function mode will be changed when "CURRENT SETTING" on CONSULT-III screen is touched.
PANIC ALRM SET	Panic alarm operation mode can be changed in this mode. The operation mode will be changed when "CURRENT SETTING" on CONSULT-III screen is touched.
TRUNK OPEN SET	Keyless trunk open operation mode can be changed in this mode. The operation mode will be changed when "CURRENT SETTING" on CONSULT-III screen is touched.
PW DOWN SET	Power window down can be changed in this mode. The operation mode will be changed when "CURRENT SETTING" on CONSULT-III screen is touched.

### PANIC ALARM SET

	MODE 1	MODE 2	MODE 3
Keyfob operation	0.5 seconds	Nothing	1.5 seconds

### HAZARD LAMP BACK SET

	MODE 1	MODE 2	MODE 3	MODE 4
Hazard lamp operation mode	Nothing	Unlock only	Lock only	Lock and Unlock

### AUTO LOCK SET

	MODE 1	MODE 2	MODE 3
Auto locking function	30 seconds	Nothing	1 minutes

### TRUNK OPEN

	MODE 1	MODE 2	MODE 3
Keyfob operation	0.5 seconds	Nothing	1.5 seconds

# REMOTE KEYLESS ENTRY SYSTEM

## < SERVICE INFORMATION >

### Data Monitor

Monitored Item	Description
IGN ON SW	Indicates [ON/OFF] condition of ignition switch in ON position.
KEY ON SW	Indicates [ON/OFF] condition of key switch.
ACC ON SW	Indicates [ON/OFF] condition of ignition switch in ACC position.
KEYLESS LOCK	Indicates [ON/OFF] condition of lock signal from keyfob.
KEYLESS UNLOCK	Indicates [ON/OFF] condition of unlock signal from keyfob.
KEYLESS PANIC	Indicates [ON/OFF] condition of panic alarm signal from keyfob.
KEYLESS TRUNK	Indicates [ON/OFF] condition of trunk signal from keyfob.
DOOR SW-DR	Indicates [ON/OFF] condition of front door switch driver side.
DOOR SW-AS	Indicates [ON/OFF] condition of front door switch passenger side.
DOOR SW-RR	Indicates [ON/OFF] condition of rear door switch RH.
DOOR SW-RL	Indicates [ON/OFF] condition of rear door switch LH.
TRNK OPN MNTR	Indicates [ON/OFF] condition of trunk room lamp switch.
CDL LOCK SW	Indicates [ON/OFF] condition of lock signal from door lock and unlock switch.
CDL UNLOCK SW	Indicates [ON/OFF] condition of unlock signal from door lock and unlock switch.
RKE LCK-UNLCK	Indicates [ON/OFF] condition of lock and unlock signal from keyfob.
RKE KEEP UNLK	Indicates [ON/OFF] condition of unlock signal from keyfob after 3 seconds.
KEY CYL LK-SW	Indicates [ON/OFF] condition of driver key cylinder lock signal.

### Active Test

Test Item	Description
FLASHER	This test is able to check right hazard reminder operation. The right hazard lamp turns on when "ON" on CONSULT-III screen is touched.
POWER WINDOW DOWN	This is displayed even when it is not equipped.
HORN	This test is able to check horn operation. The horn blows when "ON" on CONSULT-III screen is touched.
DOOR LOCK	This test is able to check door lock actuator operation. <ul style="list-style-type: none"><li>• The all door lock actuator are locked when "ALL LOCK" on CONSULT-III screen is touched.</li><li>• The all door lock actuator are unlocked when "ALL UNLOCK" on CONSULT-III screen is touched.</li></ul>

### Work Flow

INFOID:000000004407705

1. Check the symptom and customer's requests.
2. Understand outline of system. Refer to [BL-50, "System Description"](#).
3. Confirm that power door lock system operates normally.  
Refer to [BL-20](#).
4. Repair or replace any malfunctioning parts.  
Refer to [BL-58, "Trouble Diagnosis Symptom Chart"](#).
5. Does remote keyless entry system operate normally? If Yes, GO TO 6. If No, GO TO 4.
6. Inspection end.

### Trouble Diagnosis Symptom Chart

INFOID:000000004407706

#### NOTE:

- Always check the "Work Flow" before troubleshooting. Refer to [BL-58, "Work Flow"](#).
- Always check keyfob battery before replacing keyfob.

# REMOTE KEYLESS ENTRY SYSTEM

## < SERVICE INFORMATION >

Symptom	Diagnoses/service procedure	Reference page	
All functions of remote keyless entry system do not operate.	1. Check keyfob battery and function. <b>NOTE:</b> If the result of keyfob function check with CONSULT-III is OK, keyfob is not malfunctioning.	<a href="#">BL-67</a>	A B
	2. Check remote keyless entry receiver.	<a href="#">BL-65</a>	C
	3. Refer to ID Code Entry Procedure.	<a href="#">BL-68</a>	
	4. Replace BCM.	<a href="#">BCS-17</a>	
The new ID of keyfob cannot be entered.	1. Check keyfob battery and function. <b>NOTE:</b> If the result of keyfob function check with CONSULT-III is OK, keyfob is not malfunctioning.	<a href="#">BL-67</a>	D
	2. Check key switch.	<a href="#">BL-63</a>	E
	3. Check door switch.	<a href="#">BL-61</a>	
	4. Check ACC switch.	<a href="#">BL-61</a>	F
	5. Replace keyfob. Refer to ID Code Entry Procedure.	<a href="#">BL-68</a>	
	6. Replace BCM.	<a href="#">BCS-17</a>	
Door lock does not function with keyfob. (Power door lock system is "OK".)	1. Check keyfob function. (Lock) <b>NOTE:</b> If the result of keyfob function check with CONSULT-III is OK, keyfob is not malfunctioning.	<a href="#">BL-67</a>	G H
	2. Replace keyfob. Refer to ID Code Entry Procedure.	<a href="#">BL-68</a>	
	3. Check door switch.	<a href="#">BL-61</a>	
	4. Replace BCM.	<a href="#">BCS-17</a>	BL
Door unlock does not function with keyfob (Power door lock system is "OK")	1. Check keyfob function. (Unlock) <b>NOTE:</b> If the result of keyfob function check with CONSULT-III is OK, keyfob is not malfunctioning.	<a href="#">BL-67</a>	J
	2. Replace keyfob. Refer to ID Code Entry Procedure.	<a href="#">BL-68</a>	
	3. Replace BCM.	<a href="#">BCS-17</a>	K
Hazard reminder does not activate properly when pressing lock or unlock button of keyfob.	1. Check hazard reminder mode.* *: Hazard reminder mode can be changed. First check the hazard reminder setting.	<a href="#">BL-57</a>	L
	2. Check hazard function.	<a href="#">BL-64</a>	
	3. Replace BCM.	<a href="#">BCS-17</a>	
Panic alarm does not activate when panic alarm button is continuously pressed.	1. Check panic alarm mode.* *: Panic alarm mode can be changed. First check the panic alarm setting.	<a href="#">BL-57</a>	M
	2. Check keyfob battery and function. <b>NOTE:</b> If the result of keyfob function check with CONSULT-III is OK, keyfob is not malfunctioning.	<a href="#">BL-67</a>	N
	3. Check horn function.	<a href="#">BL-64</a>	O
	4. Check key switch.	<a href="#">BL-63</a>	
	5. Replace keyfob. Refer to ID Code Entry Procedure.	<a href="#">BL-68</a>	P
	6. Replace BCM.	<a href="#">BCS-17</a>	

# REMOTE KEYLESS ENTRY SYSTEM

## < SERVICE INFORMATION >

Symptom	Diagnoses/service procedure	Reference page
Trunk lid does not open when trunk opener button is continuously pressed (ignition key must be OFF).	1. Check keyfob battery and function. <b>NOTE:</b> If the result of keyfob function check with CONSULT-III is OK, keyfob is not malfunctioning.	<a href="#">BL-67</a>
	2. Check trunk lid opener actuator.	<a href="#">BL-148</a>
	3. Replace BCM.	<a href="#">BCS-17</a>
Auto door lock operation does not activate properly. (All other remote keyless entry system functions are OK.)	1. Check auto door lock operation mode.* *: Auto door lock operation mode can be changed. First check the auto door lock operation setting.	<a href="#">BL-57</a>
	2. Replace BCM.	<a href="#">BCS-17</a>
Interior lamp operation does not activate properly.	1. Check interior lamp operation.	<a href="#">BL-65</a>
	2. Replace BCM.	<a href="#">BCS-17</a>

## Keyfob Battery and Function Check

INFOID:000000004407707

### 1. CHECK KEYFOB BATTERY

- Remove keyfob battery. Refer to [BL-70, "Keyfob Battery Replacement"](#).
- Measure voltage between battery positive and negative terminals, (+) and (-).

**Voltage** : 2.5 – 3.0V

#### NOTE:

Keyfob does not function if battery is not set correctly.

#### OK or NG

- OK >> GO TO 2.  
NG >> Replace battery.

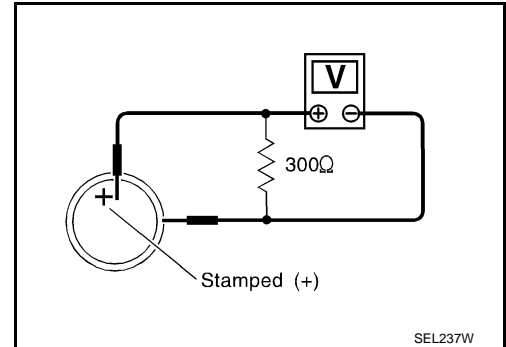

### 2. CHECK KEYFOB FUNCTION

#### Ⓜ With CONSULT-III

Check keyfob function in "DATA MONITOR" mode with CONSULT-III.

When pushing each button of keyfob, the corresponding monitor item should be turned as follows.

Condition	Monitor item	
Pushing LOCK	KEYLESS LOCK	: ON
Pushing UNLOCK	KEYLESS UNLOCK	: ON
Keep pushing UNLOCK	RKE KEEP UNLK after UNLOCK button is pushed for 3 seconds.	: ON
Pushing PANIC	KEYLESS PANIC	: ON
Pushing LOCK and UNLOCK at the same time	RKE LCK-UNLCK	: ON
Pushing TRUNK	KEYLESS TRUNK	: ON

#### ⓧ Without CONSULT-III



# REMOTE KEYLESS ENTRY SYSTEM

## < SERVICE INFORMATION >

Check keyfob function using Remote Keyless Entry Tester J-43241.

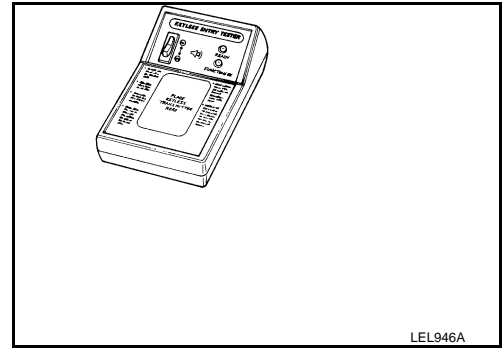

### OK or NG

- OK >> WITH CONSULT-III: Keyfob, remote keyless entry receiver and wiring harness between BCM and remote keyless entry receiver are OK. Replace BCM. Refer to [BCS-17, "Removal and Installation of BCM"](#).
- OK >> WITHOUT CONSULT-III: Keyfob is OK. Further inspection is necessary. Refer to [BL-58, "Trouble Diagnosis Symptom Chart"](#).
- NG >> WITH CONSULT-III: Further inspection is necessary. Refer to [BL-58, "Trouble Diagnosis Symptom Chart"](#).
- NG >> WITHOUT CONSULT-III: Replace keyfob. Refer to [BL-68, "ID Code Entry Procedure"](#).

## ACC Switch Check

INFOID:000000004407708

### 1.CHECK ACC SWITCH

#### With CONSULT-III

Check ACC switch ("ACC ON SW") in "DATA MONITOR" mode with CONSULT-III.

Monitor item	Condition	
ACC ON SW	Ignition switch position is ACC or ON	: ON
	Ignition switch position is OFF	: OFF

#### Without CONSULT-III

Check voltage between BCM connector and ground.

Terminals		Ignition switch condition	Voltage (V) (Approx.)
(+)	(-)		
BCM connector	Terminal	ACC or ON	Battery voltage
M18	11	OFF	0

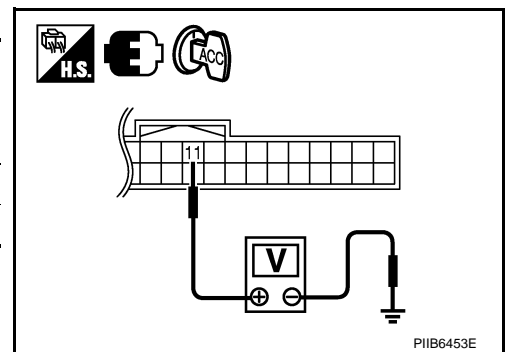

### OK or NG

- OK >> ACC switch is OK.
- NG >> Check the following.
  - 10A fuse [No. 6, located in fuse block (J/B)]
  - Harness for open or short between BCM and fuse.

## Door Switch Check

INFOID:000000004407709

### 1.CHECK DOOR SWITCHES INPUT SIGNAL

#### With CONSULT-III

# REMOTE KEYLESS ENTRY SYSTEM

## < SERVICE INFORMATION >

Check door switches ("DOOR SW-DR", "DOOR SW-AS", "DOOR SW-RL", "DOOR SW-RR") in DATA MONITOR mode with CONSULT-III. Refer to [BL-36, "CONSULT-III Function \(BCM\)"](#).

- When any doors are open:

**DOOR SW-DR : ON**  
**DOOR SW-AS : ON**  
**DOOR SW-RL : ON**  
**DOOR SW-RR : ON**

- When any doors are closed:

**DOOR SW-DR : OFF**  
**DOOR SW-AS : OFF**  
**DOOR SW-RL : OFF**  
**DOOR SW-RR : OFF**

Without CONSULT-III

Check voltage between BCM connector M18 or M19 terminals 12, 13, 47, 48 and ground.

Connector	Item	Terminals		Condition	Voltage (V) (Approx.)
		(+)	(-)		
M19	Front door switch LH	47	Ground	Open ↓ Closed	0 ↓ Battery voltage
	Rear door switch LH	48			
M18	Front door switch RH	12			
	Rear door switch RH	13			

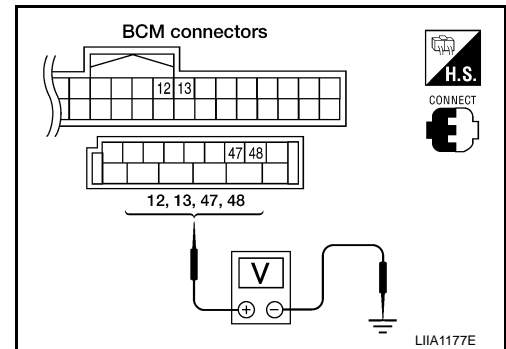

### OK or NG

- OK >> Door switch circuit is OK.  
 NG >> GO TO 2.

## 2. CHECK DOOR SWITCH CIRCUIT

1. Turn ignition switch OFF.
2. Disconnect door switch and BCM.
3. Check continuity between door switch connector B21 (Front LH), B28 (Front RH), B26 (Rear LH), B41 (Rear RH) terminal 2 and BCM connector M18, M19 terminals 12, 13, 47 and 48.

**2 - 47 : Continuity should exist.**  
**2 - 12 : Continuity should exist.**  
**2 - 48 : Continuity should exist.**  
**2 - 13 : Continuity should exist.**

4. Check continuity between door switch connector B21 (Front LH), B28 (Front RH), B26 (Rear LH), B41 (Rear RH) terminal 2 and ground.

**2 - Ground : Continuity should not exist.**

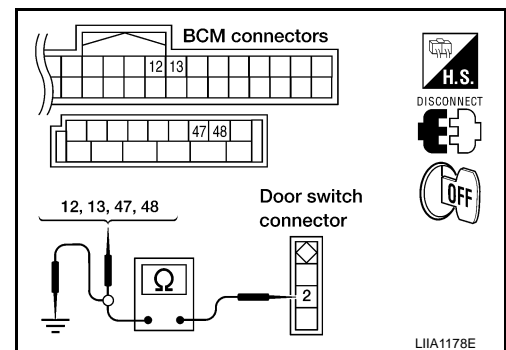

### OK or NG

- OK >> GO TO 3.  
 NG >> Repair or replace harness.

## 3. CHECK DOOR SWITCHES

# REMOTE KEYLESS ENTRY SYSTEM

## < SERVICE INFORMATION >

Check continuity between door switch terminals.

Door switch (front or rear)	Terminals		Condition	Continuity
		2	Ground	Pressed
			Released	Yes

### OK or NG

- OK >> GO TO 4.
- NG >> Replace door switch.

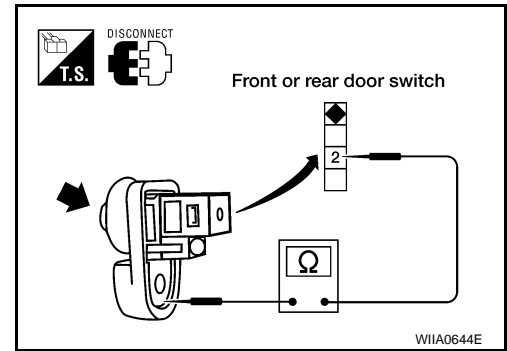

## 4.CHECK BCM OUTPUT VOLTAGE

1. Reconnect BCM connectors.
2. Check voltage between BCM connector M18, M19 terminals 12, 13, 47, 48 and ground.

- 12 - Ground : Battery voltage**
- 13 - Ground : Battery voltage**
- 47 - Ground : Battery voltage**
- 48 - Ground : Battery voltage**

### OK or NG

- OK >> Door switch circuit is OK.
- NG >> Replace BCM. Refer to [BCS-17. "Removal and Installation of BCM"](#).

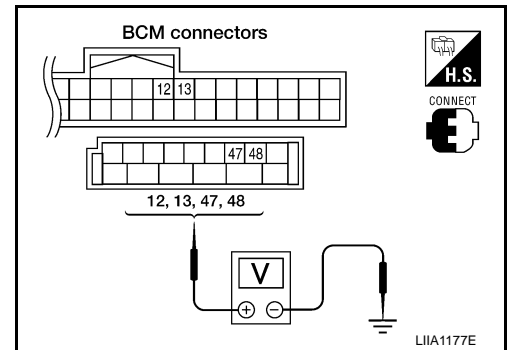

## Key Switch Check

INFOID:000000004407710

### 1.CHECK KEY SWITCH INPUT SIGNAL

#### With CONSULT-III

Check key switch "KEY ON SW" in DATA MONITOR mode with CONSULT-III. Refer to [BL-57. "CONSULT-III Function \(BCM\)"](#).

- When key is inserted into ignition key cylinder:

**KEY ON SW : ON**

- When key is removed from ignition key cylinder:

**KEY ON SW : OFF**

#### Without CONSULT-III

Check voltage between BCM connector and ground.

Connector	Terminals		Condition	Voltage (V) (Approx.)
	(+)	(-)		
M18	37	Ground	Key is inserted.	Battery voltage
			Key is removed.	0

### OK or NG

- OK >> Key switch circuit is OK.
- NG >> GO TO 2.

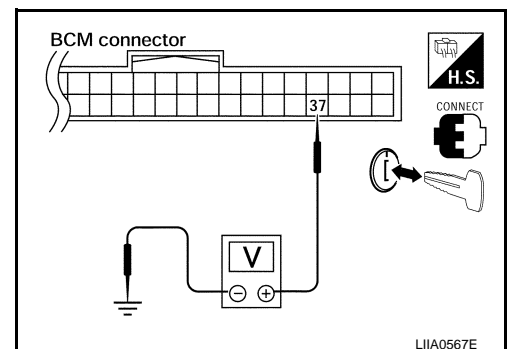

## 2.CHECK KEY SWITCH

1. Turn ignition switch OFF.
2. Disconnect key switch connector.

# REMOTE KEYLESS ENTRY SYSTEM

## < SERVICE INFORMATION >

### 3. Check key switch.

Terminals	Condition	Continuity
1 - 2	Key is inserted.	Yes
	Key is removed.	No

#### OK or NG

- OK >> Check the following.
- 10A fuse [No. 19, located in fuse block (J/B)]
  - Harness for open or short between key switch and fuse
  - Harness for open or short between BCM and key switch
- NG >> Replace key switch.

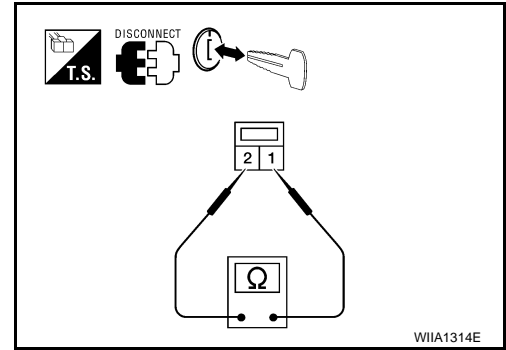

## Hazard Function Check

INFOID:000000004407712

### 1. CHECK HAZARD WARNING LAMP

Does hazard warning lamp flash with hazard switch?

#### OK or NG

- OK >> Hazard warning lamp circuit is OK.  
 NG >> Check hazard circuit. Refer to [LT-45](#).

## Horn Function Check

INFOID:000000004407712

First perform the "SELF-DIAG RESULTS" in "BCM" with CONSULT-III, then perform the trouble diagnosis of malfunction system indicated "SELF-DIAG RESULTS" of "BCM". Refer to [BL-57](#). "[CONSULT-III Function \(BCM\)](#)".

### 1. CHECK HORN FUNCTION

Does horn sound with horn switch?

#### OK or NG

- OK >> GO TO 2.  
 NG >> Check horn circuit. Refer to [WW-27](#).

### 2. CHECK IPDM E/R INPUT SIGNAL

Check voltage between IPDM E/R connector and ground.

Terminals		Voltage (V) (Approx.)
(+)	(-)	
IPDM E/R connector	Terminal	Battery voltage
E43	13	

#### OK or NG

- OK >> Replace IPDM E/R. Refer to [PG-27](#). "[Removal and Installation of IPDM E/R](#)"  
 NG >> GO TO 3.

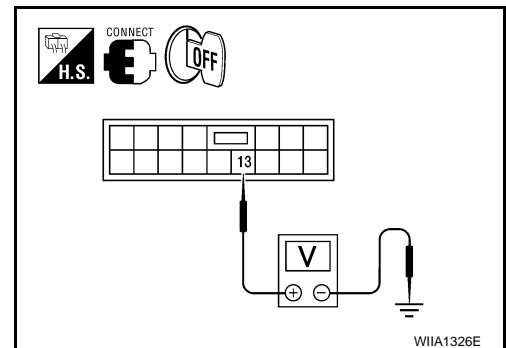

### 3. CHECK HORN RELAY CIRCUIT

1. Turn ignition switch OFF.
2. Disconnect IPDM E/R and horn relay connector.

# REMOTE KEYLESS ENTRY SYSTEM

## < SERVICE INFORMATION >

- Check continuity between IPDM E/R harness connector and horn relay harness connector.

A		B		Continuity
IPDM E/R connector	Terminal	Horn relay connector	Terminal	
E43	13	H-1	1	Yes

- Check continuity between IPDM E/R harness connector and ground.

A		Ground	Continuity
IPDM E/R connector	Terminal		
E43	13		No

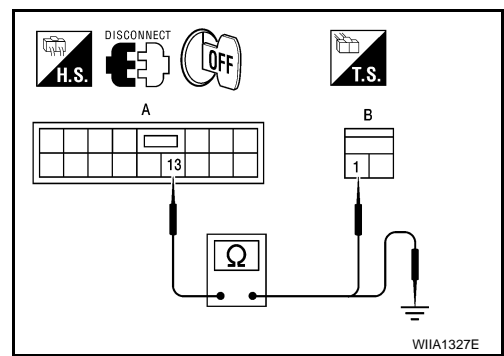

### OK or NG

- OK >> Check condition of harness and connector.
- NG >> Repair or replace harness.

## Interior Lamp Illumination Function Check

INFOID:000000004407713

### 1. CHECK INTERIOR LAMP ILLUMINATION FUNCTION

When interior room lamp switch is in "DOOR" position, open the front door (LH or RH).

#### Does interior lamp illuminate?

- YES >> Replace BCM. Refer to [BCS-17. "Removal and Installation of BCM"](#).
- NO >> Check interior lamp circuit. Refer to [LT-83](#).

## Remote Keyless Entry Receiver Check

INFOID:000000004407714

### 1. CHECK REMOTE KEYLESS ENTRY RECEIVER OUTPUT SIGNAL

- Turn ignition switch OFF.
- Check remote keyless entry receiver connector and ground signal with oscilloscope.

Terminals		Keyfob condition	Signal (Reference value)
(+)	(-)		
Remote keyless entry receiver connector	Terminal		
M15	2	Ground	<p>OCC3879D</p>
		Any button is pressed	<p>OCC3880D</p>

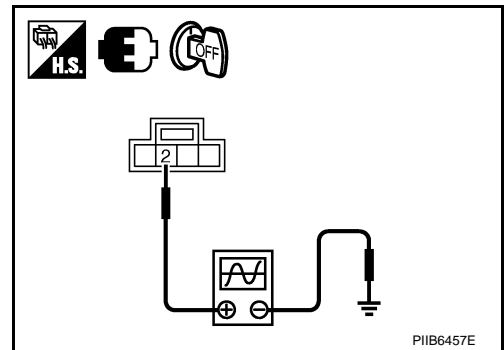

### OK or NG

# REMOTE KEYLESS ENTRY SYSTEM

## < SERVICE INFORMATION >

- OK >> Remote keyless entry receiver circuit is OK.
- NG >> GO TO 2.

### 2. CHECK REMOTE KEYLESS ENTRY RECEIVER INPUT VOLTAGE

1. Disconnect remote keyless entry receiver connector.
2. Check voltage between remote keyless entry receiver connector M15 terminal 4 and ground.

Terminals			Voltage (V) (Approx.)
(+)		(-)	
Remote keyless entry receiver connector	Terminal		
M15	4	Ground	4.5

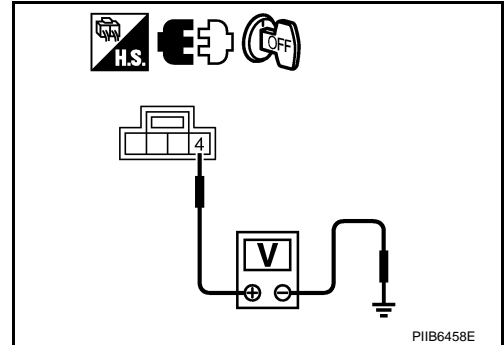

#### OK or NG

- OK >> GO TO 4.
- NG >> GO TO 3.

### 3. CHECK REMOTE KEYLESS ENTRY RECEIVER POWER SUPPLY CIRCUIT

1. Disconnect BCM connector.
2. Check continuity between BCM connector M18 (A) terminal 19 and remote keyless entry receiver connector M15 (B) terminal 4.

A		B		Continuity
BCM connector	Terminal	Remote keyless entry receiver connector	Terminal	
M18	19	M15	4	Yes

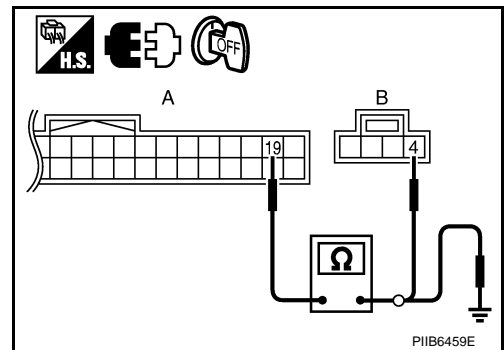

3. Check continuity between BCM connector (A) M18 terminal 19 and ground.

A		Ground	Continuity
BCM connector	Terminal		
M18	19		No

#### OK or NG

- OK >> Replace BCM. Refer to [BCS-17. "Removal and Installation of BCM"](#).
- NG >> Repair or replace the harness.

### 4. CHECK REMOTE KEYLESS ENTRY RECEIVER GROUND CIRCUIT

Check continuity between remote keyless entry receiver connector M15 terminal 1 and ground.

Remote keyless entry receiver connector	Terminal	Ground	Continuity
M15	1		Yes

#### OK or NG

- OK >> GO TO 6.
- NG >> GO TO 5.

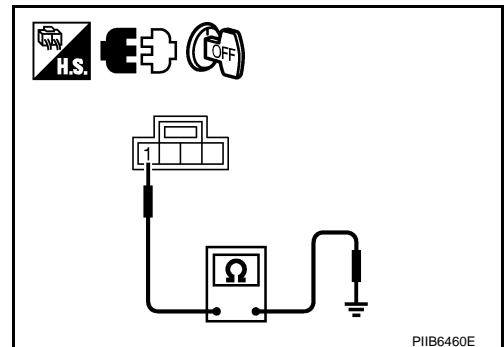

### 5. CHECK REMOTE KEYLESS ENTRY RECEIVER GROUND CIRCUIT

Check continuity between BCM connector M18 (A) terminal 18 and remote keyless entry receiver connector M15 (B) terminal 1.

# REMOTE KEYLESS ENTRY SYSTEM

## < SERVICE INFORMATION >

A		B		Continuity
BCM connector	Terminal	Remote keyless entry receiver connector	Terminal	
M18	18	M15	1	Yes

### OK or NG

- OK >> Replace BCM. Refer to [BCS-17. "Removal and Installation of BCM"](#).
- NG >> Repair or replace the harness.

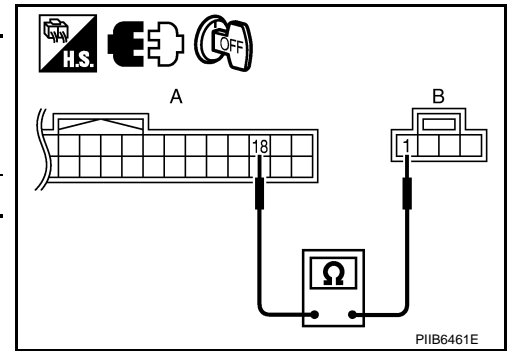

## 6.CHECK REMOTE KEYLESS ENTRY RECEIVER SIGNAL CIRCUIT

1. Check continuity between BCM connector M18 (A) terminal 20 and remote keyless entry receiver connector M15 (B) terminal 2.

A		B		Continuity
BCM connector	Terminal	Remote keyless entry receiver connector	Terminal	
M18	20	M15	2	Yes

2. Check continuity between BCM connector (A) M18 terminal 20 and ground.

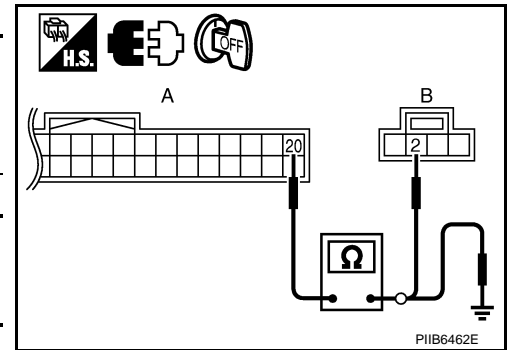

A		Ground	Continuity
BCM connector	Terminal		
M18	20		No

### OK or NG

- OK >> Replace remote keyless entry receiver. Refer to [BL-70. "Removal and Installation of Remote Keyless Entry Receiver"](#).
- NG >> Repair or replace harness.

## Keyfob Function (Lock) Check

INFOID:000000004407715

### 1.CHECK KEYFOB FUNCTION

#### Ⓜ With CONSULT-III

Check keyfob function in "DATA MONITOR" mode with CONSULT-III. When pushing lock button of keyfob, the corresponding monitor item should be turned as follows.

Test item	Condition
KEYLESS LOCK	Pushing LOCK button: ON
	Other than above: OFF

### OK or NG

- OK >> Keyfob is OK.
- NG >> Replace keyfob.

## Keyfob Function (Unlock) Check

INFOID:000000004407716

### 1.CHECK KEYFOB FUNCTION

#### Ⓜ With CONSULT-III

Check keyfob function in "DATA MONITOR" mode with CONSULT-III. When pushing unlock button of keyfob, the corresponding monitor item should be turned as follows.

# REMOTE KEYLESS ENTRY SYSTEM

## < SERVICE INFORMATION >

---

Test item	Condition
KEYLESS UNLOCK	Pushing UNLOCK button: ON
	Other than above: OFF

### OK or NG

- OK >> Keyfob is OK.
- NG >> Replace keyfob.

## ID Code Entry Procedure

INFOID:000000004407717

### KEYFOB ID SET UP WITH CONSULT-III

#### **NOTE:**

- If a keyfob is lost, the ID code of the lost keyfob must be erased to prevent unauthorized use. A specific ID code can be erased with CONSULT-III. However, when the ID code of a lost keyfob is not known, all controller ID codes should be erased. After all ID codes are erased, the ID codes of all remaining and/or new keyfobs must be re-registered.
- When registering an additional keyfob, the existing ID codes in memory may or may not be erased. If five ID codes are stored in memory, when an additional code is registered, only the oldest code is erased. If less than five ID codes are stored in memory, when an additional ID code is registered, the new ID code is added and no ID codes are erased.
- Entry of maximum five ID codes is allowed. When more than five ID codes are entered, the oldest ID code will be erased.
- Even if same ID code that is already in the memory is input, the same ID code can be entered. The code is counted as an additional code.

1. Connect CONSULT-III.
2. Touch "MULTI REMOTE ENT".
3. Touch "WORK SUPPORT".
4. The following items can be set up:
  - "REMO CONT ID CONFIR"  
Use this mode to confirm if a keyfob ID code is registered or not.
  - "REMO CONT ID REGIST"  
Use this mode to register a keyfob ID code.

#### **NOTE:**

**Register the ID code when keyfob or BCM is replaced, or when additional keyfob is required.**

- "REMO CONT ID ERASUR"  
Use this mode to erase a keyfob ID code.



# REMOTE KEYLESS ENTRY SYSTEM

< SERVICE INFORMATION >

## KEYFOB ID SET UP WITHOUT CONSULT-III

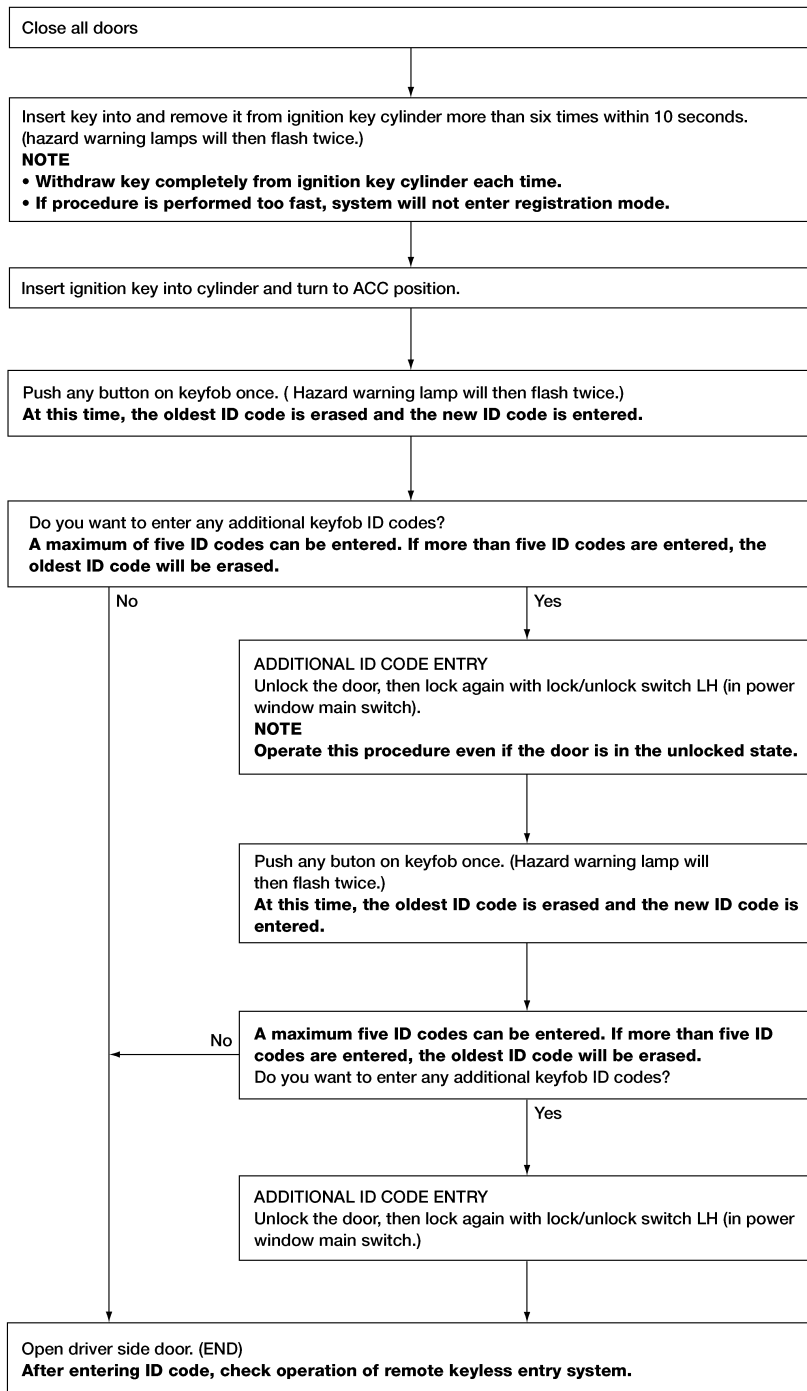

### NOTE:

- If a keyfob is lost, the ID code of the lost keyfob must be erased to prevent unauthorized use. A specific ID code can be erased with CONSULT-III. However, when the ID code of a lost keyfob is not known, all controller ID codes should be erased. After all ID codes are erased, the ID codes of all remaining and/or new keyfobs must be re-registered.

To erase all ID codes in memory, register one ID code (keyfob) five times. After all ID codes are erased, the ID codes of all remaining and/or new keyfobs must be re-registered.

LIA1513E

# REMOTE KEYLESS ENTRY SYSTEM

## < SERVICE INFORMATION >

- When registering an additional keyfob, the existing ID codes in memory may or may not be erased. If five ID codes are stored in memory, when an additional code is registered, only the oldest code is erased. If less than five ID codes are stored in memory, when an additional ID code is registered, the new ID code is added and no ID codes are erased.
- If you need to activate more than two additional new keyfobs, repeat the procedure “Additional ID code entry” for each new keyfob.
- Entry of maximum five ID codes is allowed. When more than five ID codes are entered, the oldest ID code will be erased.
- Even if same ID code that is already in the memory is input, the same ID code can be entered. The code is counted as an additional code.

## Keyfob Battery Replacement

INFOID:000000004407718

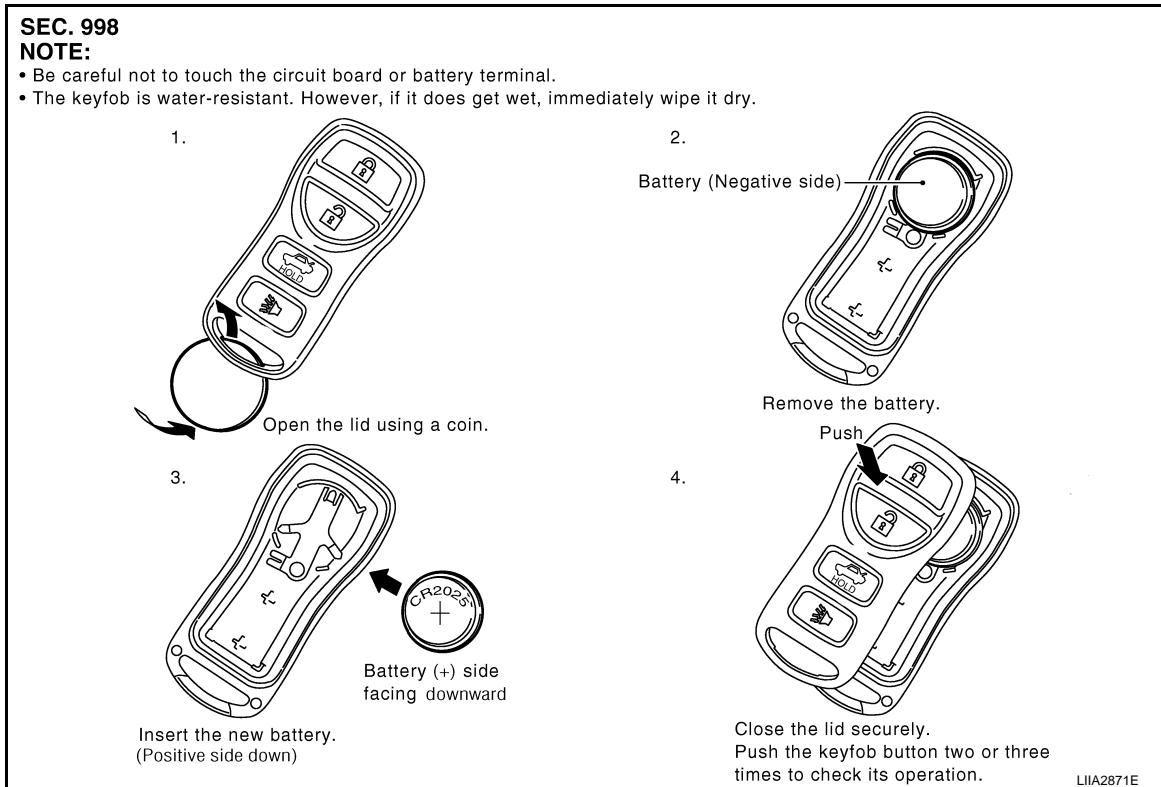

## Removal and Installation of Remote Keyless Entry Receiver

INFOID:000000004407719

### REMOVAL

1. Disconnect the battery negative terminal.
2. Remove glove box assembly. Refer to [IP-12, "Removal and Installation"](#).
3. Remove the screw (a) disconnect and remove the remote keyless entry receiver (1).

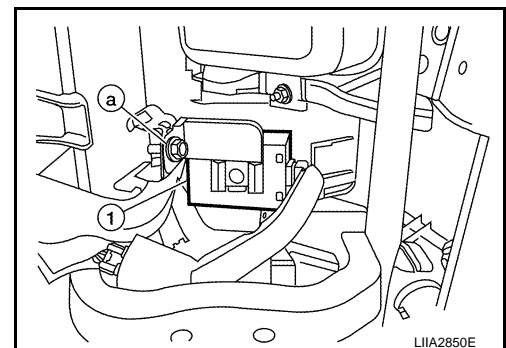

### INSTALLATION

Installation is in the reverse order of removal.

# INTELLIGENT KEY SYSTEM

< SERVICE INFORMATION >

## INTELLIGENT KEY SYSTEM

### Component Parts and Harness Connector Location

INFOID:000000004407720

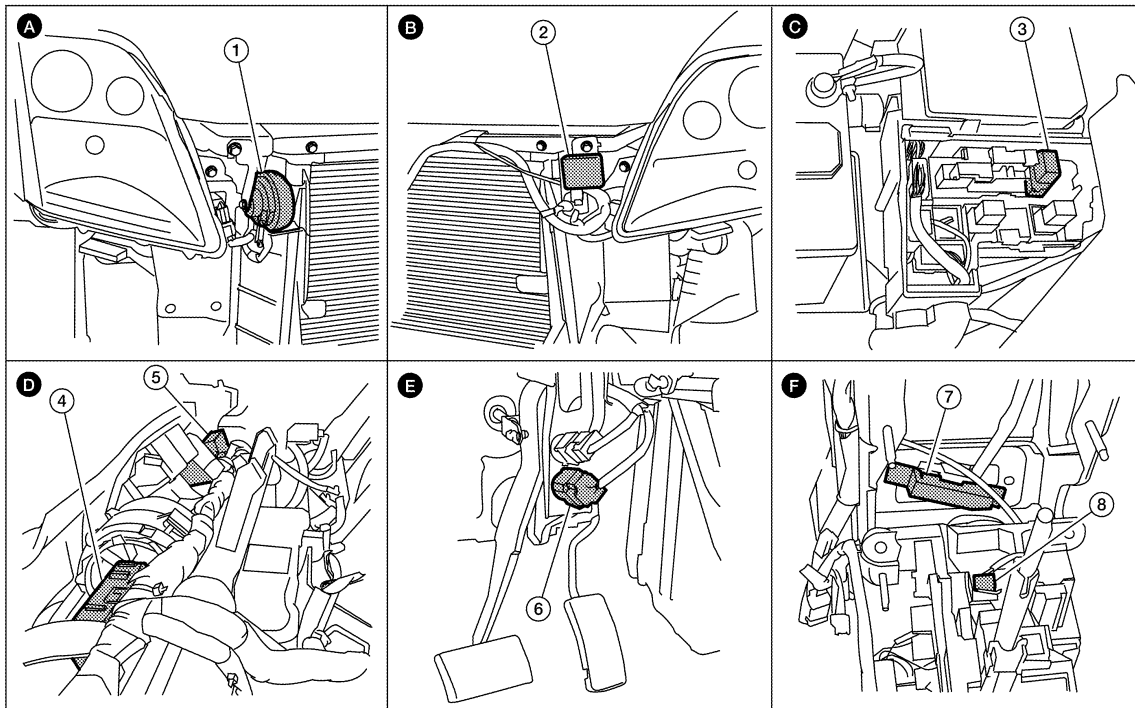
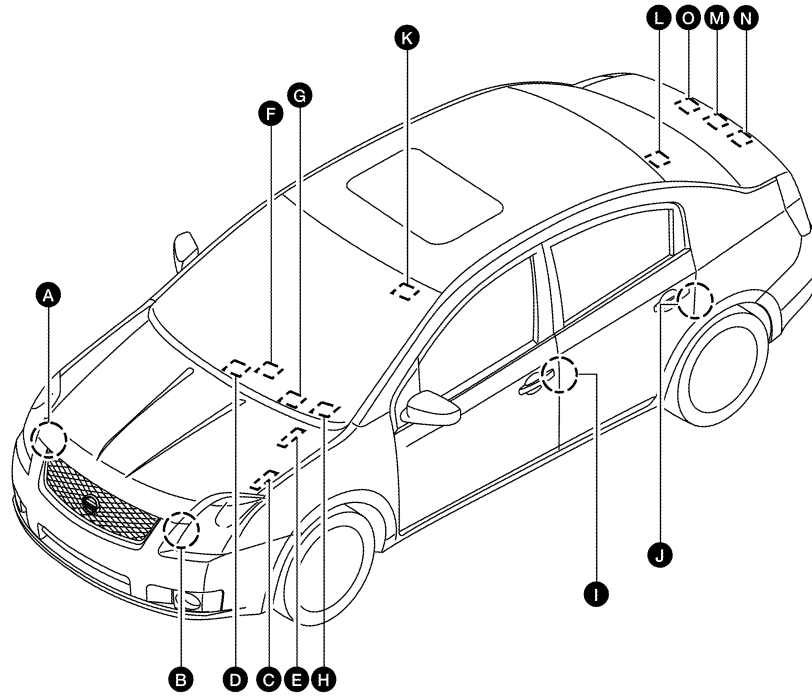

A  
B  
C  
D  
E  
F  
G  
H  
BL  
J  
K  
L  
M  
N  
O  
P

B1IA0002E

# INTELLIGENT KEY SYSTEM

< SERVICE INFORMATION >

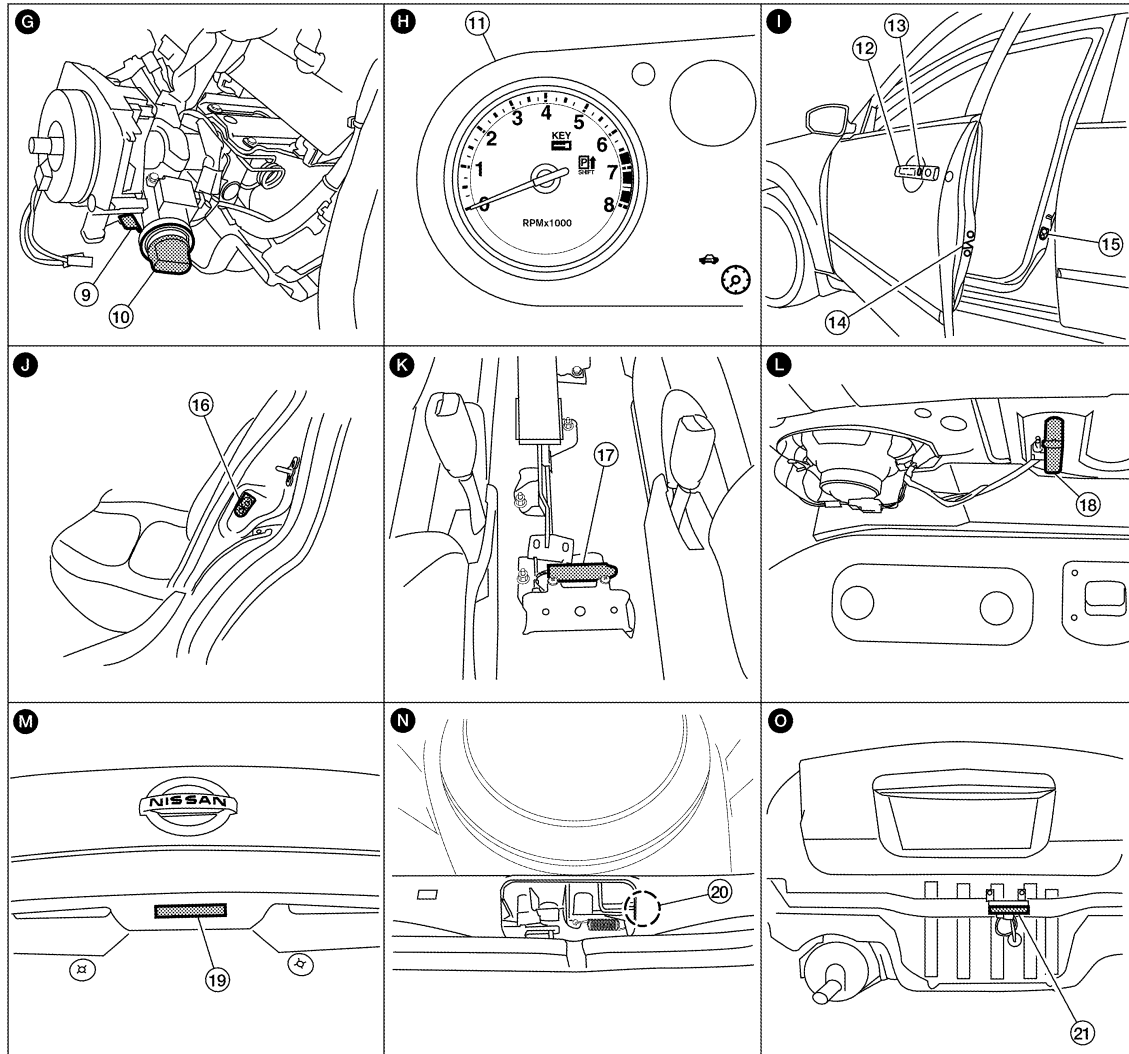

B1IA0003E

- |   |   |   |
|---|---|---|
| 1. Horn E57, E58<br>(view with front fascia removed)                  | 2. Intelligent key warning buzzer E26<br>(view with front fascia removed) | 3. Horn relay H-1   |
| 4. BCM M18, M19, M20<br>(view with instrument panel removed)          | 5. Intelligent Key Unit M42   | 6. Stop lamp switch E60   |
| 7. Instrument panel antenna M25<br>(view with center console removed) | 8. CVT device (park position switch) M38                                  | 9. Steering lock solenoid M27<br>(view with steering wheel removed) |
| 10. Key switch and ignition knob switch M49                           | 11. Combination meter M24<br>(warning lamp indicators)                    | 12. Front outside handle key antenna LH D4, RH D103                 |
| 13. Front outside handle request switch LH D4, RH D103                | 14. Front door lock assembly LH (door unlock sensor) D9                   | 15. Front door switch LH B21, RH B28                                |
| 16. Rear door switch LH B26, RH B41                                   | 17. Front console antenna B18<br>(view with front console removed)        | 18. Rear parcel shelf antenna B45<br>(view from inside trunk)       |
| 19. Trunk opener request switch T5                                    | 20. Trunk room lamp switch B57  | 21. Rear bumper antenna B49<br>(view with rear fascia removed)      |

## System Description

INFOID:000000004407721

- The Intelligent Key system is a system that makes it possible to lock and unlock the door locks (door lock/unlock function), open the trunk (trunk open function), and start the engine (engine start function) by carrying around the Intelligent Key (without some key operation), which operates based on the results of electronic ID verification using two-way communications between the Intelligent Key and the vehicle (Intelligent Key unit).

### CAUTION:

The driver should always carry the Intelligent Key

# INTELLIGENT KEY SYSTEM

## < SERVICE INFORMATION >

- Operation of the remote control buttons on the Intelligent Key also provides the same functions as the remote control entry system (Remote keyless entry functions).
- If an action that does not meet the operating conditions of the Intelligent Key system is taken, the chime (inside vehicle) goes off to inform the driver (Warning chime functions).
- When a door lock is locked or unlocked with request switch or remote control button operation, the hazard lamps flash and the Intelligent Key warning buzzer (front of vehicle) sounds (Hazard and horn reminder function).
- Even if the Intelligent Key battery is completely discharged, the door locks can be locked and unlocked and the engine started with the mechanical key built into the Intelligent Key.
- The settings for each function can be changed with the CONSULT-III.
- If an Intelligent Key is lost, a new Intelligent Key can be registered. A maximum of 4 Intelligent Keys can be registered.
- It has been made possible to diagnose the system and register an Intelligent Key with the CONSULT-III.

## DOOR LOCK/UNLOCK/TRUNK OPEN FUNCTION

Only when pressing the request switch, it is possible to lock and unlock the door and open the trunk by carrying around the Intelligent Key (without some key operation).

### System Diagram

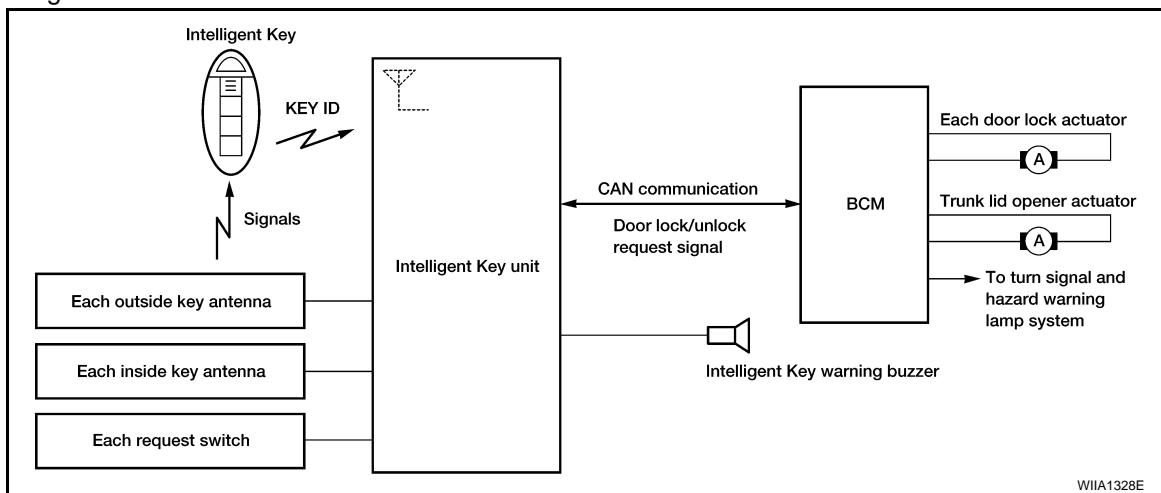

### Operation Description

- When the Intelligent Key unit detects that each request switch is pressed, it starts the outside antenna corresponding to the pressed request switch and sends the request signal to the Intelligent Key. And then, make sure that the Intelligent Key is near the door or the trunk.
- If the Intelligent Key is within the outside antenna detection area, it receives the request signal and sends the key ID signal to the Intelligent Key unit.
- Intelligent Key receives the key ID signal and compares it with the registered key ID.
- If the key ID check result is OK, the Intelligent Key unit sends the door lock/unlock or trunk open request signal to BCM (Body control module) via CAN communication line.
- Intelligent Key unit sends the door lock/unlock signal and sounds Intelligent Key warning buzzer (front of vehicle) warning (lock: 2 times, unlock: 1 time, trunk open: 4 times) at the same time.
- When BCM receives the door lock/unlock signal, it operates door lock actuator and flashes the hazard lamp (lock: 2 times, unlock: 1 time) at the same time as an operation check.
- When BCM receives the trunk open request signal, it operates the trunk lid opener actuator and opens the trunk.

### Operation Condition

If the following conditions are not satisfied, door lock/unlock or trunk open operations will not response even if the request switch is operated.

# INTELLIGENT KEY SYSTEM

## < SERVICE INFORMATION >

Each request switch operation	Operation condition
Lock operation	<ul style="list-style-type: none"> <li>All doors are closed</li> <li>Intelligent Key is outside the vehicle</li> <li>Intelligent Key is within outside key antenna detection area even if another Intelligent Key is inside the vehicle</li> <li>OFF position warning chime is not operated</li> </ul>
Unlock Operation	<ul style="list-style-type: none"> <li>Intelligent Key is outside the vehicle</li> <li>Intelligent Key is within outside key antenna detection area</li> </ul>
Trunk open operation	<ul style="list-style-type: none"> <li>Intelligent Key is in the outside key antenna (rear bumper) detection area and Intelligent Key is not inside vehicle.</li> <li>Intelligent Keys are in the outside key antenna (rear bumper) detection area and Intelligent Key is inside vehicle. But both Intelligent Key IDs are different.</li> </ul>

### Outside Key Antenna Detection Area

The outside key antenna detection area of door lock/unlock function is in the range of approximately 80 cm (31.50 in) surrounding the driver and passenger door handles. The outside key antenna detection area of trunk open function is in the range of approximately 80 cm (31.50 in) surrounding Trunk opener request switch. However, this operating range depends on the ambient conditions.

### Key Reminder Function

Key reminder functions have the following 2 functions.

Key reminder function	Operation condition	Operation
When the door is open to closed	Key reminder function is operated when <ul style="list-style-type: none"> <li>Intelligent Key is inside the vehicle</li> <li>Any door is open</li> <li>All doors are locked by door lock and unlock switch or door lock knob</li> <li>All doors are closed</li> </ul>	<ul style="list-style-type: none"> <li>All doors unlock operation</li> <li>Sound Intelligent Key warning buzzer (front of vehicle) for 3 seconds</li> </ul>
When the trunk is closed	Key reminder function is operated when <ul style="list-style-type: none"> <li>Intelligent Key is inside trunk room</li> <li>All doors are closed</li> <li>All doors are locked</li> <li>Trunk is closed</li> </ul>	<ul style="list-style-type: none"> <li>Trunk open operation.</li> <li>Sound Intelligent Key warning buzzer (front of vehicle) for 10 seconds</li> </ul>

### CAUTION:

- The above function operates when the Intelligent Key is inside the vehicle. However, there may be times when the Intelligent Key cannot be detected, and this function will not operate when the Intelligent Key is on the instrument panel, rear parcel shelf, or in the glove box. Also, this system sometimes does not operate if the Intelligent Key is in the door pocket of an open door.
- While the key reminder function is operated when the trunk is open/closed and the chime sounds, if the following operations are performed, the key reminder function is cleared and chime sounds are stopped.
  - Remote control door lock button operation of Intelligent Key
  - Remote control door unlock button operation of Intelligent Key
  - When the trunk is closed, the Intelligent Key is not inside the vehicle
  - When any door is open

### Selective Unlock Function

When a LOCK signal is sent from front door request switch LH or RH, all doors will be locked.

When an UNLOCK signal is sent from front door request switch LH or RH once, that door will be unlocked.

Then, if an UNLOCK signal is sent from the same front door request switch again within 1 minute, all other doors will be unlocked.

### Hazard and Horn Reminder

When doors are locked or unlocked by a door request switch, Intelligent Key unit sends hazard request signal to BCM via CAN communication line. BCM flashes hazard warning lamps as a reminder.

Intelligent Key unit sends a chirp signal to the Intelligent Key warning buzzer (front of vehicle) as a reminder.

The hazard and buzzer reminder has a horn chirp mode (C mode) and a non-horn chirp mode (S mode).

# INTELLIGENT KEY SYSTEM

## < SERVICE INFORMATION >

Operating function of hazard and horn reminder

	C mode		S mode	
	Lock	Unlock	Lock	Unlock
Door request switch operation	Lock	Unlock	Lock	Unlock
Hazard warning lamp flash	Twice	Once	Twice	—
Warning buzzer (front of vehicle)	Twice	Once	—	—

Hazard and buzzer reminders do not operate if any door switch is ON (OPEN door) and ignition switch is ON.  
**How to change hazard and horn reminder mode**

### With CONSULT-III

Hazard and horn reminder can be changed using "HAZARD ANSWER BACK", "ANSWER BACK WITH I-KEY LOCK" and "ANSWER BACK WITH I-KEY UNLOCK" mode in "WORK SUPPORT". Refer to [BL-97, "CONSULT-III Application Item"](#).

### Without CONSULT-III

Refer to Owner's Manual for instructions.

### Auto Door Lock Function

When all doors are locked, ignition knob switch is OFF (when ignition switch is not pressed) and key switch is OFF (when mechanical key is not inserted in key cylinder), doors are unlocked with a door request switch.

When Intelligent Key unit does not receive the following signals within 1 minute, all doors are locked.

- Door switch is ON (door is opened)
- Door is locked
- Ignition knob switch is ON (ignition switch is pressed)
- Key switch is ON (mechanical key is inserted in key cylinder)

Auto door lock mode can be changed by "AUTO RELOCK TIMER" mode in "WORK SUPPORT". Refer to [BL-97, "CONSULT-III Application Item"](#).

### Room Lamp Operation

When the following conditions are met:

- Condition of interior lamp switch is in DOOR position
- Door switch is OFF (when all the doors are closed)

Intelligent Key system turns on interior lamp (for 30 seconds) by receiving UNLOCK signal from a door request switch. For detailed description, refer to "Room Lamp Operation".

### List of Operation Related Parts

Parts marked with × are the parts related to operation.

Door lock/trunk open function	Intelligent Key	Key switch	Ignition knob switch	Door unlock sensor	Door switch	Trunk lamp switch	Front door request switch (LH, RH)	Trunk opener request switch	Door lock actuator	Trunk lid opener actuator	Inside key antenna	Front outside antenna (LH, RH)	Rear bumper antenna	Intelligent Key warning buzzer	Intelligent Key unit	CAN communication system	BCM	Hazard warning lamp
Door lock/unlock function by request switch	×			×	×		×		×		×	×			×	×	×	
Door lock/unlock function by mechanical key									×									×
Trunk open function by the trunk opener switch	×					×		×		×			×		×	×	×	
Hazard and horn reminder function														×	×	×	×	×
Key reminder function	×			×	×		×	×	×		×	×	×	×	×	×	×	×
Selective unlock function by request switch (LH side)	×						×		×		×	×			×	×	×	
Auto door lock function	×	×	×		×		×								×	×	×	

# INTELLIGENT KEY SYSTEM

## < SERVICE INFORMATION >

### REMOTE KEYLESS ENTRY FUNCTIONS

#### Door Lock/Unlock Function

The Intelligent Key has the same functions as the remote control entry system. Therefore, it can be used in the same manner as the remote control transmitter by operating the door lock/unlock button and trunk open button.

#### System Diagram

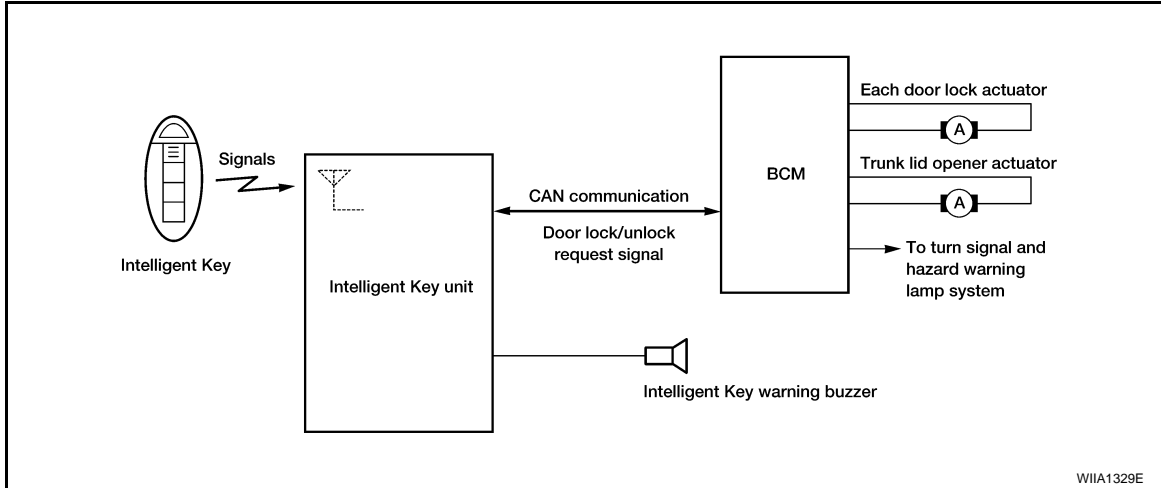

#### Door Lock/Unlock Function

- When door lock/unlock button of the Intelligent Key is pressed, lock signal or unlock signal is sent from Intelligent Key to Intelligent Key unit.
- Intelligent Key unit sends the door lock/unlock request signal to BCM via CAN communication line.
- When BCM receives the door lock/unlock signal, it operates door lock actuator and flashes the hazard lamp (lock: 2 times, unlock: 1 time) at the same time as an operation check.

#### Trunk Open Function

- When pressing the trunk button of the Intelligent Key, the trunk open signal is sent from the Intelligent Key to the Intelligent Key unit.
- Intelligent Key unit sends trunk open request signal to BCM via CAN communication line and sounds Intelligent Key warning buzzer (front of vehicle) 4 times at the same time.
- When BCM receives the trunk open request signal, it operates the trunk lid opener actuator and opens the trunk.

#### Operation Condition

Remote control operation	Operation condition
Lock	<ul style="list-style-type: none"> <li>• All doors closed</li> <li>• OFF position warning chime is not operated.</li> </ul>
Unlock	—
Trunk open	<ul style="list-style-type: none"> <li>• Ignition switch is in OFF position.</li> <li>• Press and hold the trunk open button for 0.5 second or more</li> </ul>

#### Selective Unlock Function

When a LOCK signal is sent from remote control of Intelligent Key, all doors will be locked.

When an UNLOCK signal is sent from remote control of Intelligent Key once, driver's door will be unlocked.

Then, if an UNLOCK signal is sent from remote control of Intelligent Key again within 1 minute, all other door will be unlocked.

#### Hazard and Horn Reminder

When doors are locked or unlocked by remote control of Intelligent Key, Intelligent Key unit sends hazard and horn request signal to BCM via CAN communication line.

BCM flashes hazard warning lamps as a reminder and sends horn chirp signal to IPDM E/R. IPDM E/R sounds horn as a reminder.

The hazard and horn reminder has a horn chirp mode (C mode) and a non-horn chirp mode (S mode).



# INTELLIGENT KEY SYSTEM

## < SERVICE INFORMATION >

Operating function of hazard and horn reminder

	C mode		S mode	
	Lock	Unlock	Lock	Unlock
Remote control of Intelligent Key operation	Lock	Unlock	Lock	Unlock
Hazard warning lamp flash	Twice	Once	Twice	—
Horn sound	Once	—	—	—

Hazard and horn reminders do not operate if any door switch is ON (door is OPEN) and ignition switch is ON.  
**How to change hazard and horn reminder mode**

### 🔑 With CONSULT-III

Hazard and horn reminder can be changed using “HORN WITH KEYLESS LOCK” and “HAZARD ANSWER BACK” mode in “WORK SUPPORT”. Refer to [BL-97, "CONSULT-III Application Item"](#).

### ⊗ Without CONSULT-III

Refer to Owner's Manual for instructions.

### Auto Door Lock Function

When all doors are locked, ignition knob switch is OFF (when ignition switch is not pressed) and key switch is OFF (when mechanical key is not inserted in key cylinder), doors are unlocked with remote control of Intelligent Key. When Intelligent Key unit does not receive the following signals within 1 minute, all doors are locked.

- Door switch is ON (door is opened)
- Door is locked
- Ignition knob switch is ON (ignition switch is pressed)
- Key switch is ON (mechanical key is inserted in key cylinder)

Auto door lock mode can be changed by “AUTO RELOCK TIMER” mode in “WORK SUPPORT”. Refer to [BL-97, "CONSULT-III Application Item"](#).

### Panic Alarm Function

When ignition knob switch is OFF (when ignition switch is not pressed) and key switch is OFF (when mechanical key is not inserted in key cylinder), Intelligent Key unit receives PANIC ALARM signal from remote control of Intelligent Key.

Intelligent Key unit sends alarm request signal to BCM via CAN communication line.

BCM turns on and off headlamp intermittently and sends theft warning horn signal to IPDM E/R. Then, IPDM E/R turns on and off horn intermittently.

The headlamp flashes and the horn sounds intermittently.

The alarm automatically turns off:

- After 25 seconds
- When Intelligent Key unit receives any signal from remote control of Intelligent Key
- When a door request switch is pressed (Intelligent Key is outside vehicle)

Panic alarm function mode can be changed by “PANIC ALARM DELAY” mode in “WORK SUPPORT”. Refer to [BL-97, "CONSULT-III Application Item"](#).

### Room Lamp Illumination Operation

When the following conditions are met:

- Condition of interior lamp switch is in DOOR position
- Door switch OFF (when all the doors are closed)

Intelligent Key system turns on interior lamp (for 30 seconds) by receiving UNLOCK signal from remote control of Intelligent Key. For detailed description, refer to "Room Lamp Operation".

### List of Operation Related Parts

Parts marked with × are the parts related to operation.

A  
B  
C  
D  
E  
F  
G  
H  
J  
K  
L  
M  
N  
O  
P

BL

# INTELLIGENT KEY SYSTEM

## < SERVICE INFORMATION >

Remote keyless entry functions	Intelligent Key	Key switch	Ignition knob switch	Front door request switch (LH, RH)	Door switch	Trunk lamp switch	Door lock actuator	Trunk lid opener actuator	Intelligent Key warning buzzer	Intelligent Key unit	CAN communication system	BCM	Combination meter	Hazard warning lamp	Horn	IPDM E/R	Head lamp
Door lock/unlock function by remote control button	×				×		×			×	×	×					
Trunk open function by remote control button	×					×		×		×	×	×					
Hazard and horn reminder function	×								×	×	×	×	×	×	×	×	
Selective unlock function	×				×		×			×	×	×					
Keyless power window down (open) function	×	×								×		×					
Auto door lock function	×	×	×		×					×	×	×					
Panic alarm function	×			×						×	×	×			×	×	×

## ENGINE START FUNCTION

When the registered Intelligent Key is carried, the engine can be started without inserting the key.

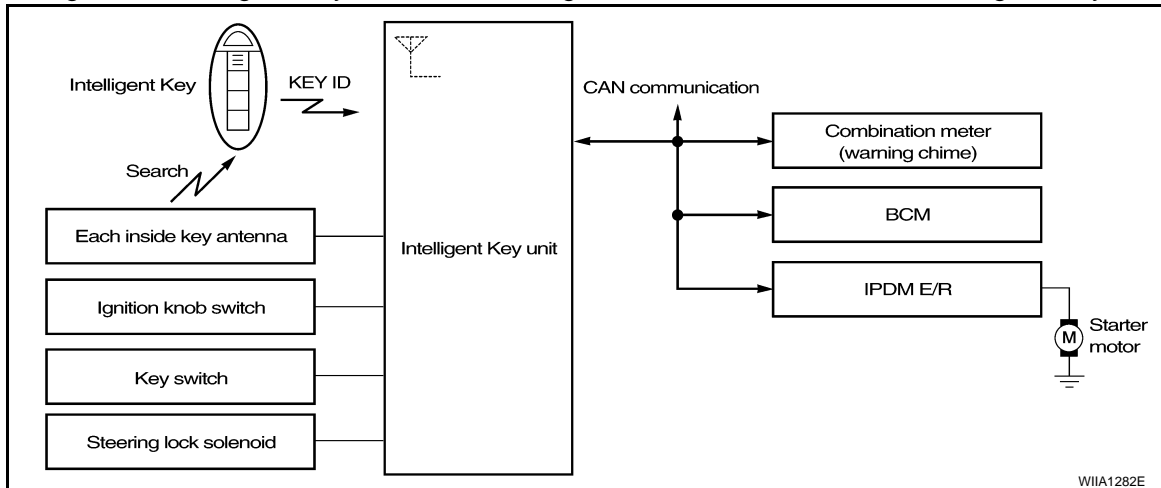

When ignition knob switch is ON (press ignition switch), Intelligent Key unit searches Intelligent Key in the vehicle using inside key antenna.

When Intelligent Key is inside the vehicle, it performs the following operation.

- Illuminate green "KEY" warning lamp in combination meter.
- Released steering lock and ignition switch can be turned from OFF to ACC, ON or START position.

### NOTE:

If Intelligent Key is not registered, "KEY" warning lamp in combination meter illuminates red.

- Intelligent Key sends engine start signal via CAN communication line.

When ignition switch turns to START position, BCM sends starter request signal to IPDM E/R. Then, engine starts.

Even if Intelligent Key battery runs down, Intelligent Key unit can start engine with mechanical key built into Intelligent Key. For details, refer to [BL-170](#).

All of the originally supplied Intelligent Key IDs have been registered in Intelligent Key system.

If requested by the vehicle owner, a maximum of four Intelligent Key IDs can be registered into the Intelligent Key system components.

### List of Operation Related Parts

Parts marked with × are the parts related to operation.

# INTELLIGENT KEY SYSTEM

## < SERVICE INFORMATION >

Engine start functions	Intelligent Key	Key switch	Ignition knob switch	Inside key antenna	Intelligent Key unit	CAN communication system	BCM	Combination meter	IPDM E/R	NATS antenna amp.	steering lock solenoid
Engine start function by the Intelligent Key	×		×	×	×	×	×	×	×		×
Engine start function by the mechanical key		×			×	×	×		×	×	×

### WARNING CHIME/BUZZER/LAMPS FUNCTION

#### Operation Description

The following warning chime (combination meter), intelligent key warning buzzer (front of vehicle), and warning lamps "KEY" and "P-SHIFT" (combination meter) are given to the user as warning information while using the intelligent key system.

- Ignition switch warning chime
- Ignition key warning chime
- OFF position warning chime
- OFF position warning chime (after door closed)
- Take away warning chime
- Take away warning chime (from window)
- Door lock operation warning chime
- Intelligent key low battery warning
- P position warning

**NOTE:**

For key-in-ignition warning chime related issues only, refer to [DI-48](#).

#### Operation Condition

Operation	Condition	Intelligent Key warning sound	Warning lamp illuminates
Ignition switch warning chime	<ul style="list-style-type: none"> <li>• Key switch is OFF.</li> <li>• Ignition switch is in the ACC, OFF or LOCK position. [ignition switch is pressed (ignition knob switch is ON)].</li> <li>• Driver door is open.</li> </ul>	Chime (Instrument panel)	—
Ignition key warning chime (When mechanical key is used)	<ul style="list-style-type: none"> <li>• Mechanical key is inserted in ignition switch (key switch is ON).</li> <li>• Ignition switch is in the ACC, OFF or LOCK position.</li> <li>• Driver door is open.</li> </ul>	Chime (Instrument panel)	—
OFF position warning chime	<ul style="list-style-type: none"> <li>• Ignition switch is turned from ACC to OFF. [ignition switch is pressed (ignition knob switch is ON)].</li> <li>• Ignition switch is in the LOCK position and pressed for 1 second.</li> </ul>	Chime (Instrument panel)	—
OFF position warning chime (after door closed)	When driver door is opened and then closed while the OFF position warning chime above is operating.	Buzzer (front of vehicle)	—
Take away warning chime	<ul style="list-style-type: none"> <li>• Engine is running.</li> <li>• Door open to close.</li> <li>• Intelligent Key is not found inside vehicle.</li> </ul>	Buzzer (front of vehicle)	"KEY" (red) blinking
Take away warning chime (from window)	<ul style="list-style-type: none"> <li>• Engine is running.</li> <li>• Door is closed.</li> <li>• Intelligent Key is not found inside vehicle.</li> </ul>	Chime (Instrument panel)	"KEY" (red) blinking

# INTELLIGENT KEY SYSTEM

## < SERVICE INFORMATION >

Operation	Condition	Intelligent Key warning sound	Warning lamp illuminates
Door lock operation warning chime	When request switch is pushed under the following conditions: <ul style="list-style-type: none"> <li>• All door are closed.</li> <li>• Door is unlocked.</li> <li>• Intelligent Key is inside vehicle.</li> </ul>	Buzzer (front of vehicle)	—
Intelligent Key low battery warning	When Intelligent Key battery is low, Intelligent Key unit is detected after ignition switch is turned ON.	—	“KEY” (green) blinking
P position warning	When selector lever is in other than P position, ignition switch is turned from ON to OFF.	—	“P-SHIFT”

### List of Operation Related Parts

Parts marked with × are the parts related to operation.

Warning and alarm functions	Intelligent Key	Key switch	Ignition knob switch	Ignition switch ACC position input signal	Ignition switch ON position input signal	Door switch	Door request switch	Inside key antenna	Front outside antenna (LH, RH)	Rear bumper antenna	Intelligent Key warning buzzer	Intelligent Key unit	CAN communication system	BCM	Combination meter	CVT device (park position switch)
	Ignition switch warning chime			×		×	×						×			
Ignition key warning chime (When mechanical key used)		×			×	×							×	×	×	
OFF position warning chime			×	×	×						×	×				
OFF position warning chime (after door close)			×	×	×	×					×	×				
Take away warning chime	×		×			×		×			×	×				×
Take away warning chime (from window)	×		×			×		×			×	×				×
Door lock operation warning chime	×		×			×	×	×	×		×	×				
Intelligent Key low battery warning	×				×			×				×				×
P position warning					×							×			×	×

### CHANGE SETTINGS FUNCTION

The settings for each function can be changed with the CONSULT-III.

#### Changing Settings Using CONSULT-III

The settings for the Intelligent Key system functions can be changed using CONSULT-III (WORK SUPPORT). Refer to [BL-97. "CONSULT-III Application Item"](#).

#### NOTE:

Once a function setting is changed, it will remain effective even if the battery is disconnected.

### INTELLIGENT KEY REGISTRATION

Intelligent Key-ID registration is performed using the CONSULT-III.

#### CAUTION:

- After a new Intelligent Key-ID is registered, be sure to check the function.
- When registering an additional Intelligent Key-ID, take any Intelligent Keys already registered and Intelligent Keys for any other vehicles out of the vehicle before starting.

CONSULT-III can be used to check and delete Intelligent Key-IDs.

For further information, see the **CONSULT-III Operation Manual NATS**.

### STEERING LOCK SOLENOID REGISTRATION

# INTELLIGENT KEY SYSTEM

## < SERVICE INFORMATION >

---

### Steering Lock Solenoid ID Registration

**CAUTION:**

- The method for registering a steering lock solenoid ID depends on the status of the steering lock solenoid and Intelligent Key unit (new or old unit).
- After registration is completed, press ignition switch with an Intelligent Key in the vehicle so that it can be turned, and confirm that it cannot be turned even when ignition switch is pressed without an Intelligent Key in the vehicle.

For further information, see the CONSULT-III Operation Manual NATS-IVIS/NVIS.

### CAN Communication System Description

INFOID:000000004407722

Refer to [LAN-6. "System Description"](#).

A  
B  
C  
D  
E  
F  
G  
H  
BL  
J  
K  
L  
M  
N  
O  
P

# INTELLIGENT KEY SYSTEM

< SERVICE INFORMATION >

## Schematic

INFOID:000000004407723

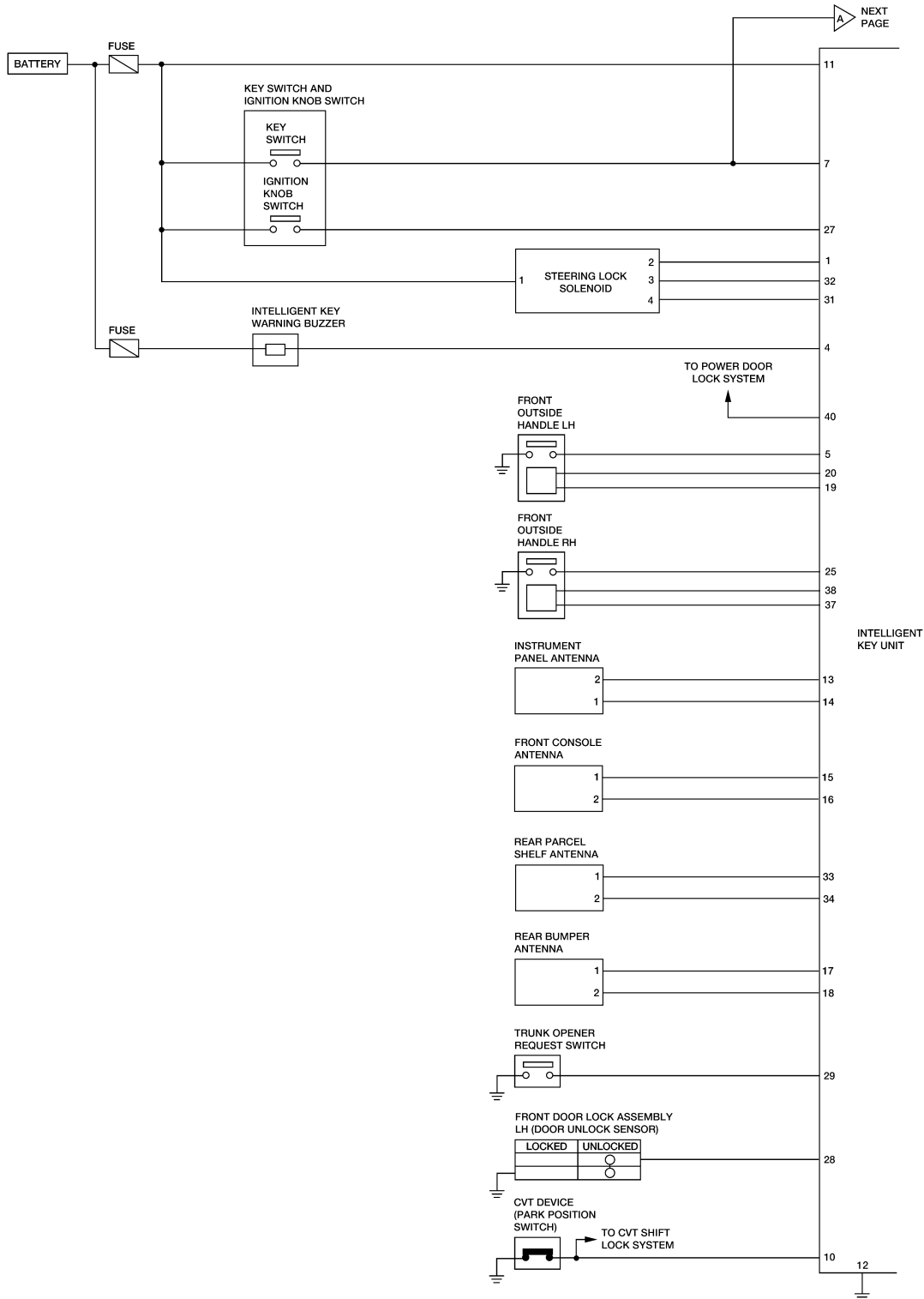

ABKWA0329GE

# INTELLIGENT KEY SYSTEM

< SERVICE INFORMATION >

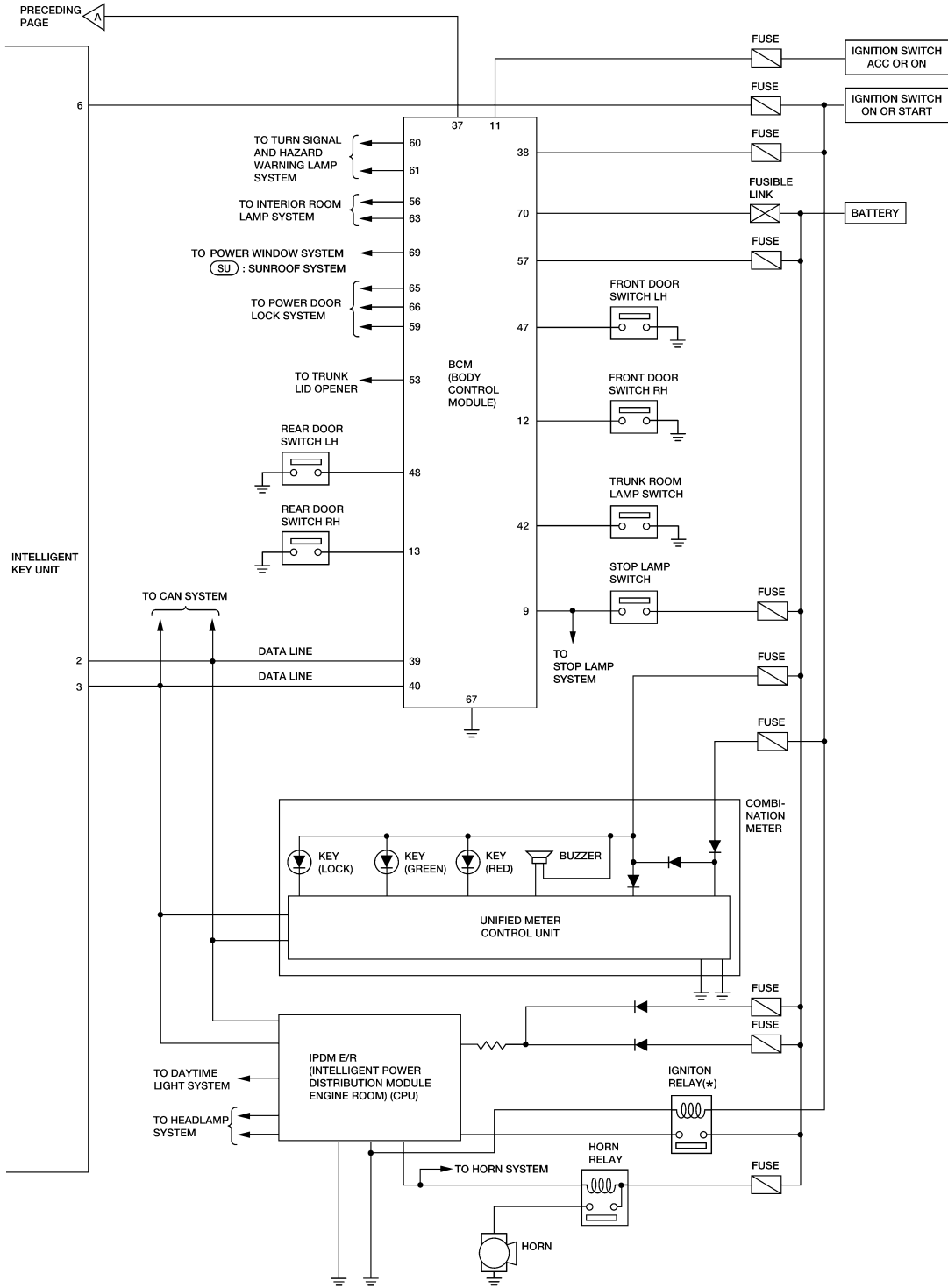

\* : THIS RELAY IS BUILT INTO THE IPDM E/R (INTELLIGENT POWER DISTRIBUTION MODULE ENGINE ROOM). (SU) : WITH SUNROOF

ABKWA0330GE

A  
B  
C  
D  
E  
F  
G  
H  
BL  
J  
K  
L  
M  
N  
O  
P

# INTELLIGENT KEY SYSTEM

< SERVICE INFORMATION >

## Wiring Diagram - Intelligent Key -

INFOID:000000004407724

BL-I/KEY-01

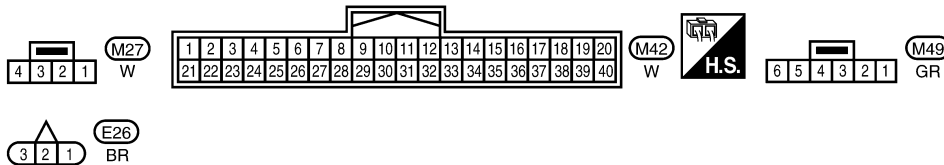
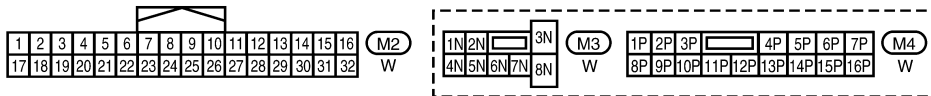
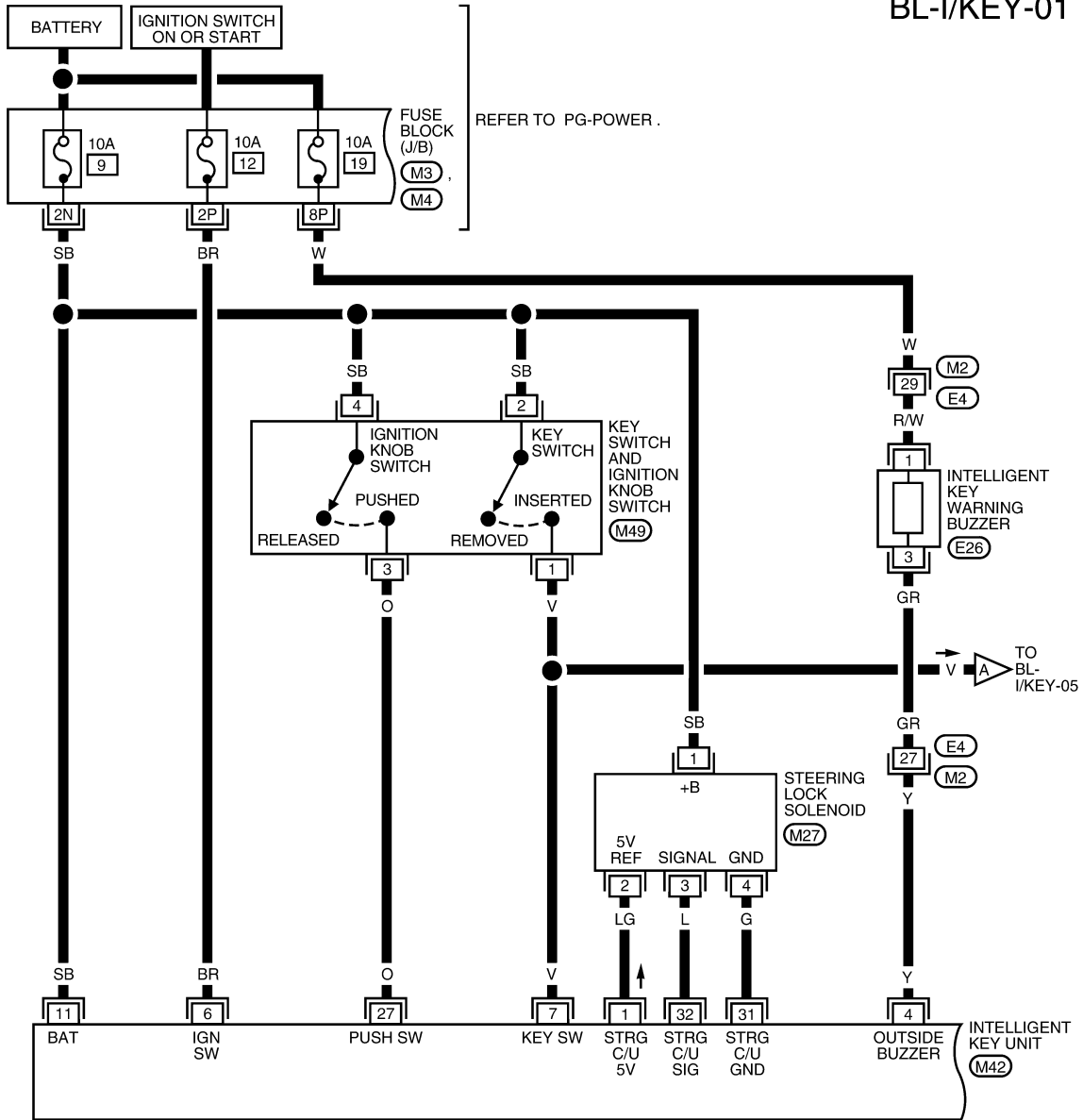

WIWA2197E



# INTELLIGENT KEY SYSTEM

< SERVICE INFORMATION >

BL-I/KEY-02

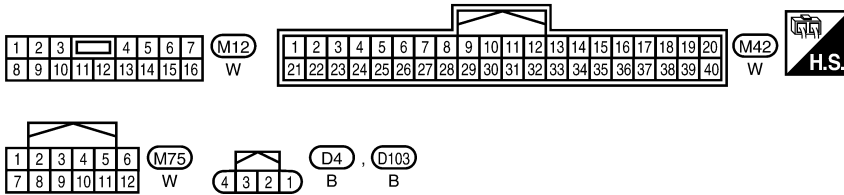
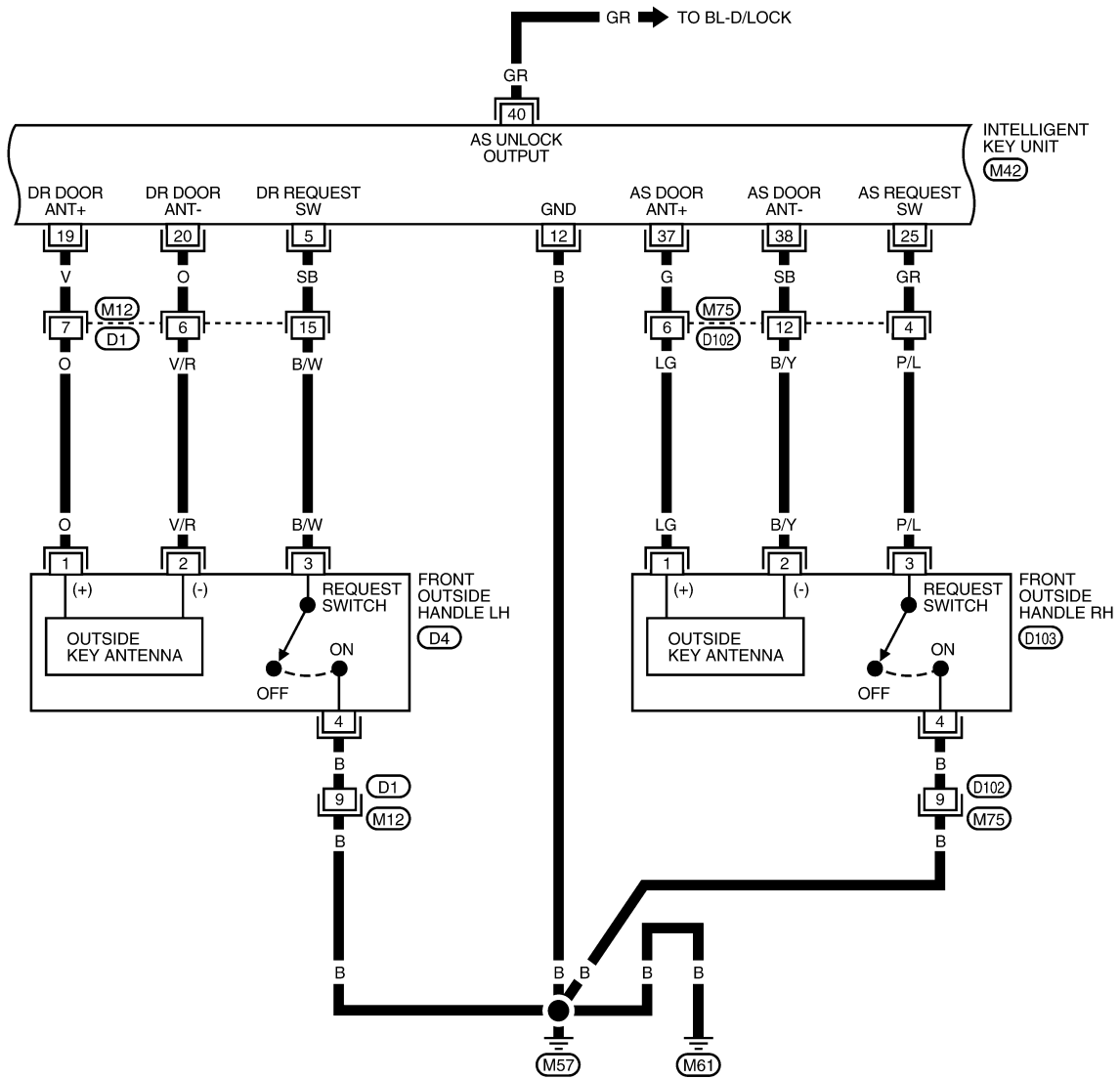

LIWA0561E

A  
B  
C  
D  
E  
F  
G  
H  
I  
J  
K  
L  
M  
N  
O  
P



# INTELLIGENT KEY SYSTEM

< SERVICE INFORMATION >

BL-I/KEY-03

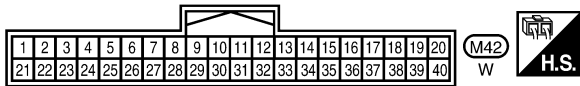
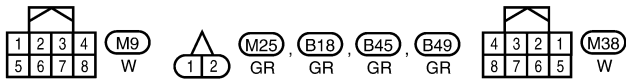
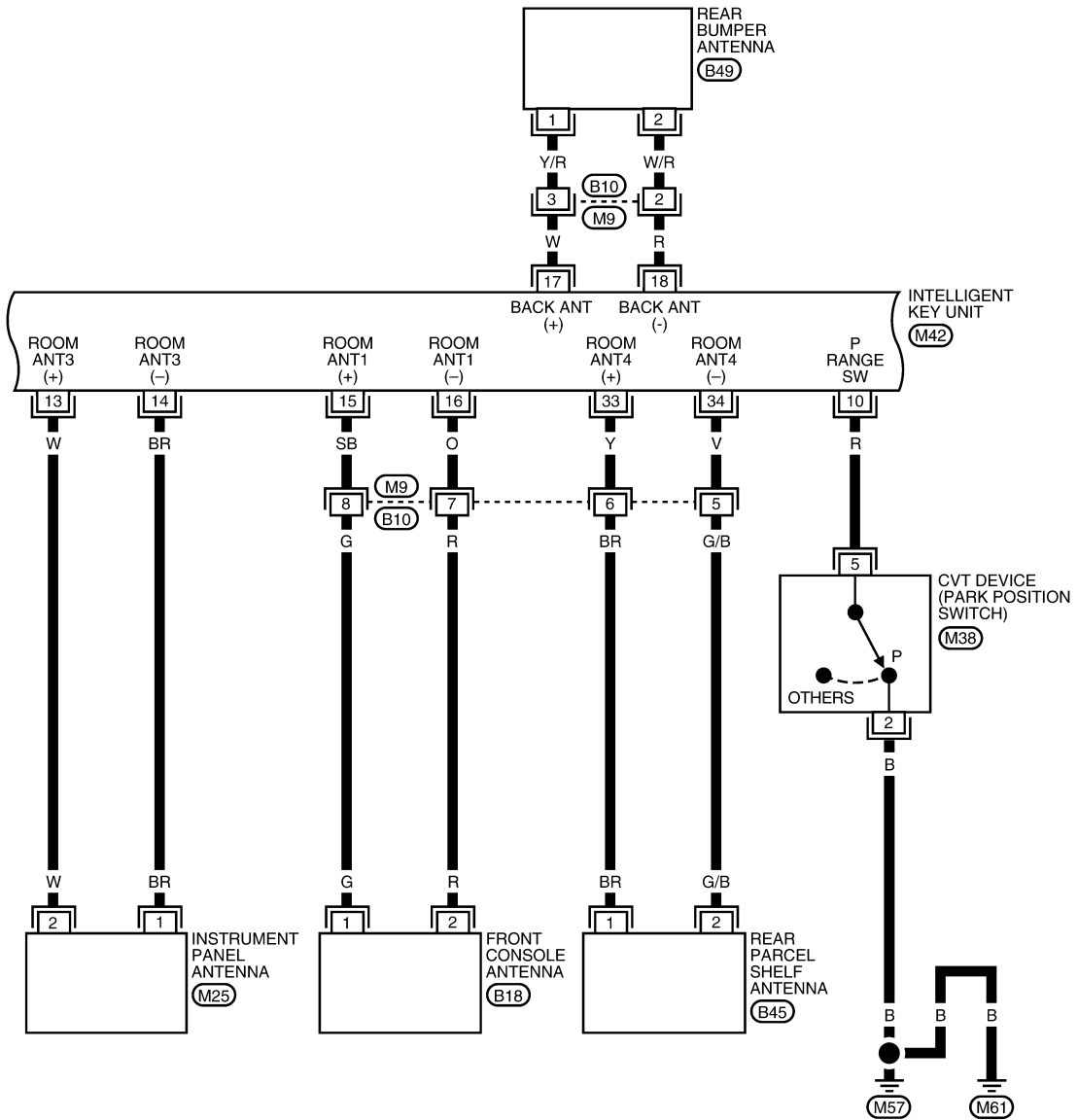

WIWA2198E

# INTELLIGENT KEY SYSTEM

< SERVICE INFORMATION >

BL-I/KEY-04

— : DATA LINE

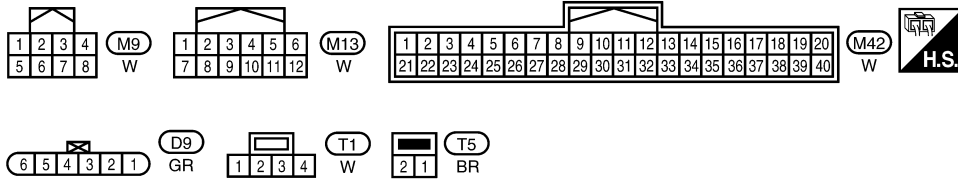
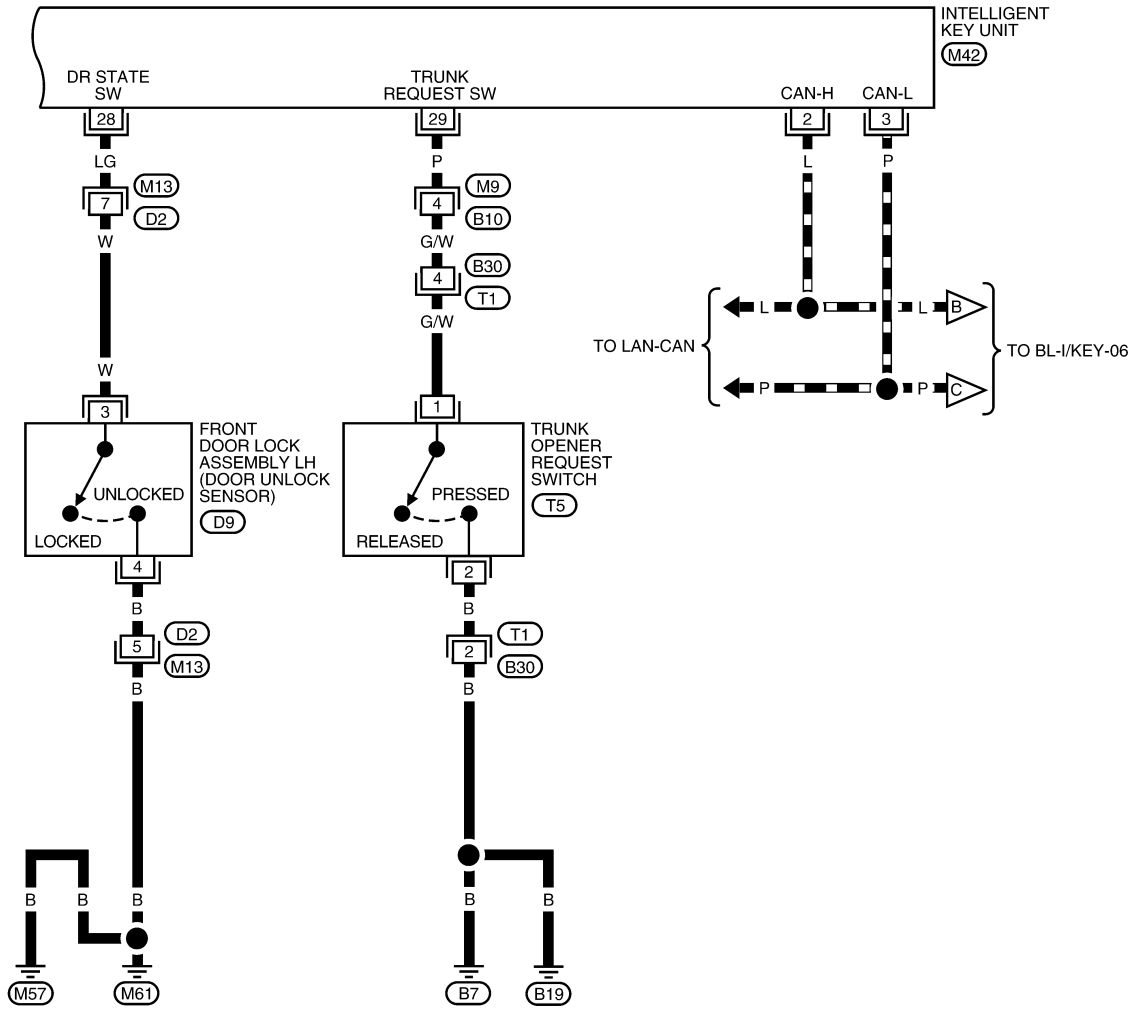

AWKWA0125GI

A  
B  
C  
D  
E  
F  
G  
H  
BL  
J  
K  
L  
M  
N  
O  
P

# INTELLIGENT KEY SYSTEM

< SERVICE INFORMATION >

BL-I/KEY-05

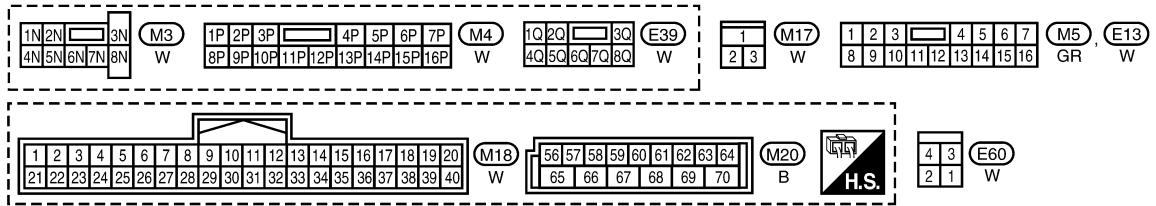
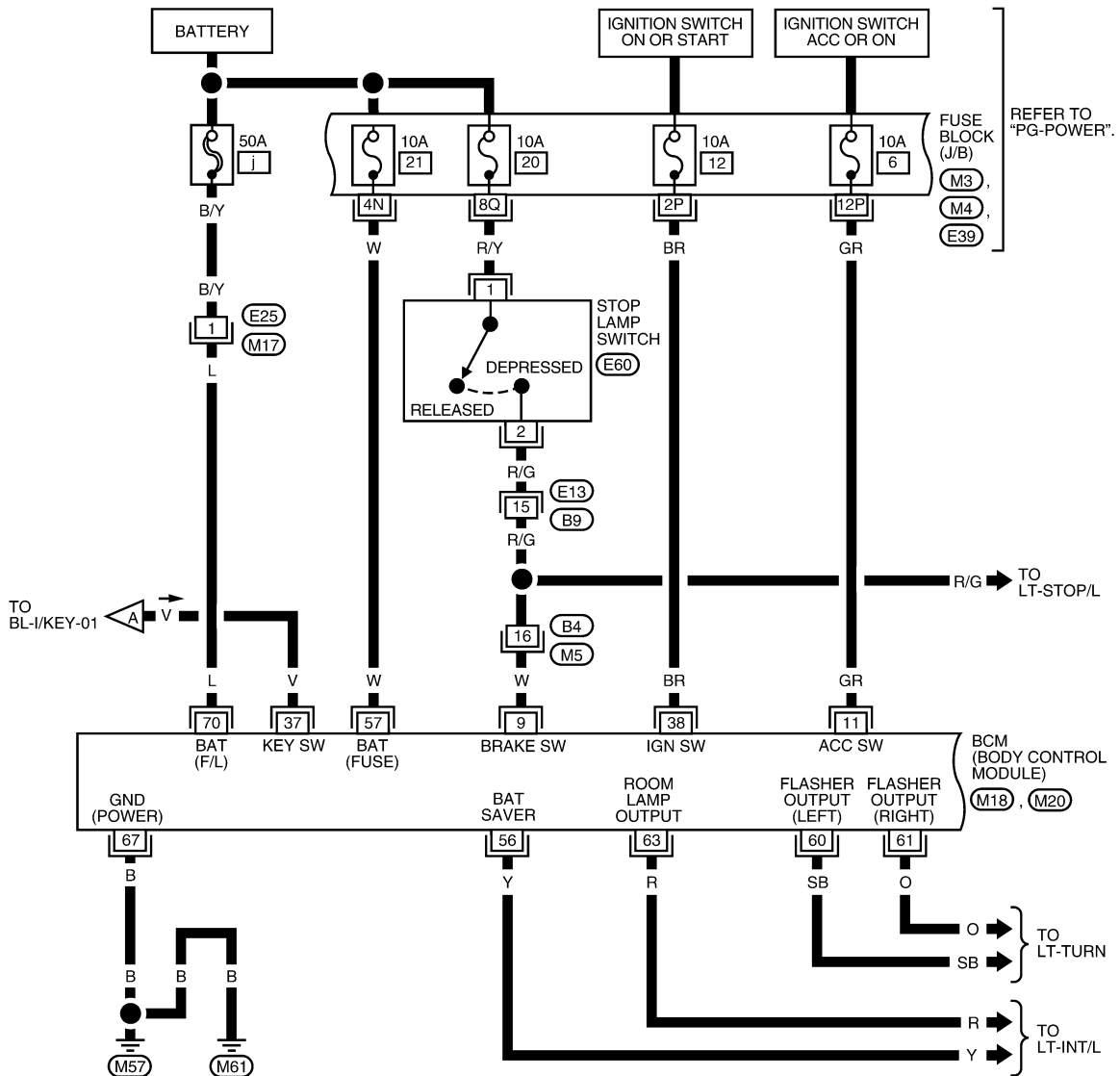

AWKWA0135GI

# INTELLIGENT KEY SYSTEM

< SERVICE INFORMATION >

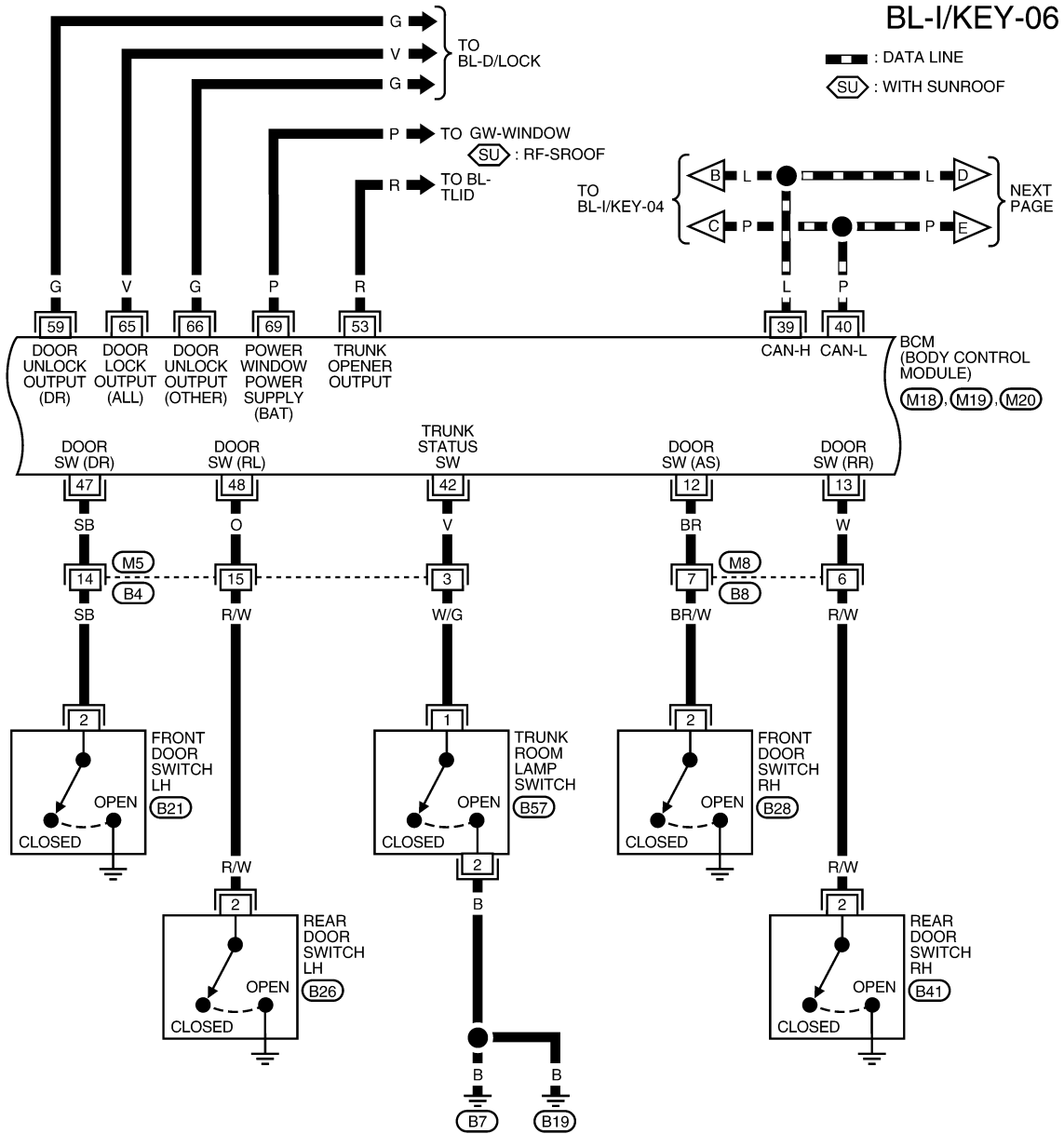

1	2	3	4	5	6	7		
8	9	10	11	12	13	14	15	16

(M5) GR (M8) W

1	2	3	4	5	6	7	8	9	10	11	12	13	14	15	16	17	18	19	20
21	22	23	24	25	26	27	28	29	30	31	32	33	34	35	36	37	38	39	40

(M18) W (M19) W (M20) B

1
2
3

(B21) W (B26) W (B28) W (B41) W (B57) W

ABKWA0331GE

# INTELLIGENT KEY SYSTEM

< SERVICE INFORMATION >

BL-I/KEY-07

▬ : DATA LINE

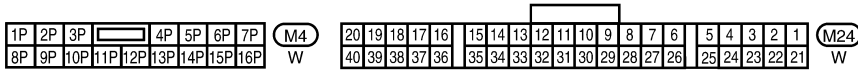
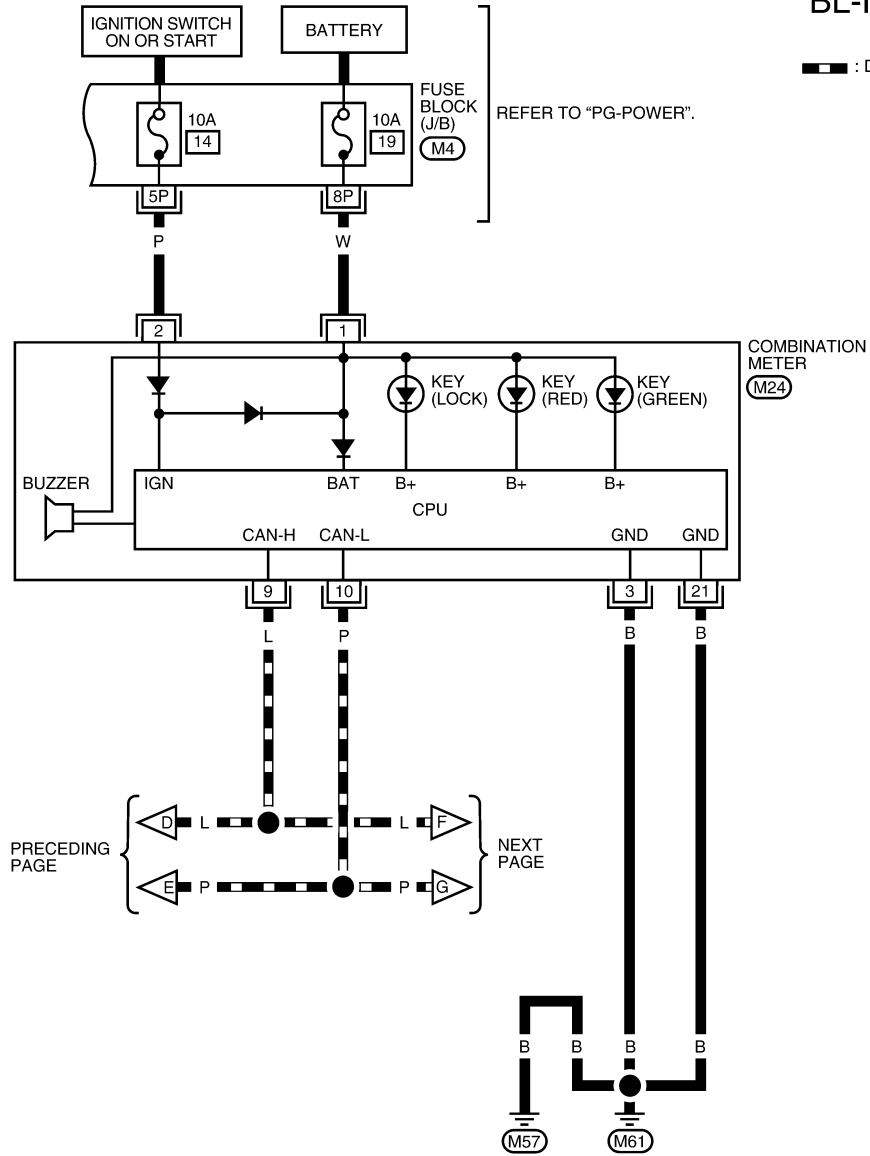

WIIA2202E

# INTELLIGENT KEY SYSTEM

< SERVICE INFORMATION >

BL-I/KEY-08

— : DATA LINE  
 ◀MR▶ : WITH MR20DE

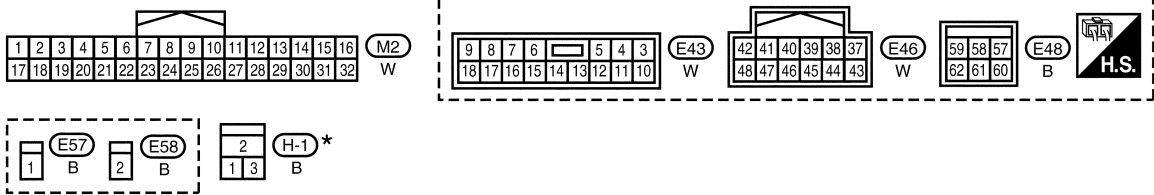
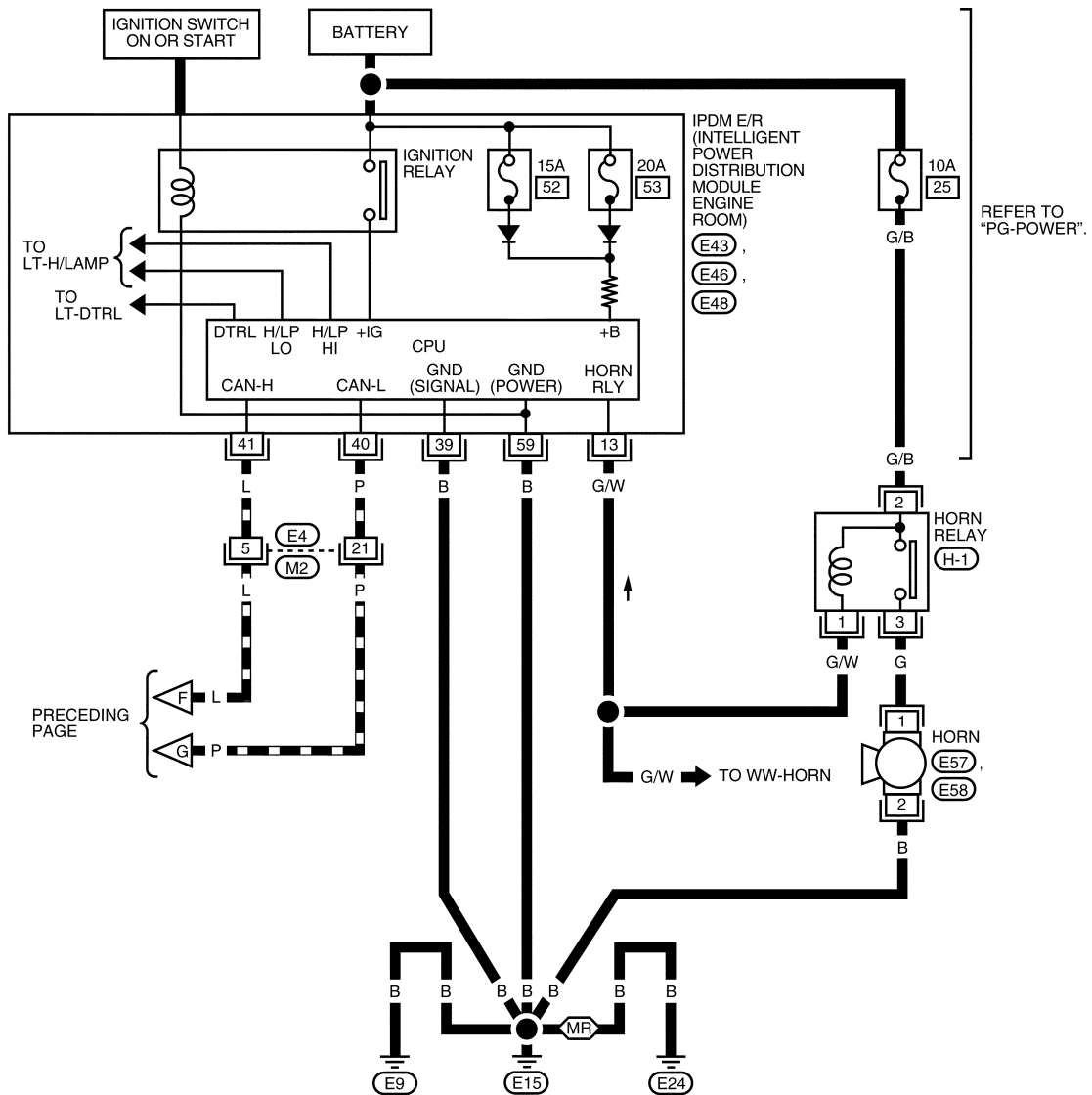

\* : THIS CONNECTOR IS NOT SHOWN IN "HARNESS LAYOUT" OF PG SECTION.

WIWA2324E

A  
B  
C  
D  
E  
F  
G  
H  
I  
J  
K  
L  
M  
N  
O  
P

BL

# INTELLIGENT KEY SYSTEM

< SERVICE INFORMATION >

## Intelligent Key Unit Harness Connector Terminal Layout

INFOID:000000004407725

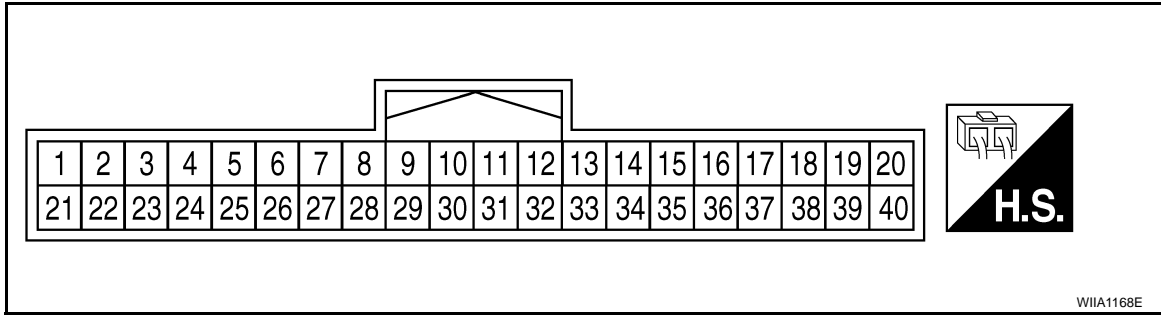

## Terminal and Reference Value for Intelligent Key Unit

INFOID:000000004407726

Terminal	Wire Color	Item	Condition		Voltage (V) Approx.	
			Ignition Switch Position	Operation or Conditions		
1	LG	Steering lock solenoid power supply	LOCK	—	5	
2	L	CAN-H	—	—	—	
3	P	CAN-L	—	—	—	
4	Y	Intelligent Key warning buzzer	LOCK	Operate door request switch.	Buzzer OFF	Battery voltage
					Sound buzzer	0
5	SB	Front door request switch LH	—	Press door request switch (driver side).	0	
				Other than above	5	
6	BR	Ignition switch (ON)	ON	—	Battery voltage	
7	V	Key switch	LOCK	Insert mechanical key into ignition switch.	Battery voltage	
				Remove mechanical key from ignition switch.	0	
10	R	CVT device (park position switch)	ON	Shift lever in park position.	0	
				Other than above	Battery voltage	
11	SB	Power source (Fuse)	—	—	Battery voltage	
12	B	Ground	—	—	0	
13	W	Instrument panel antenna (+) signal	LOCK	<ul style="list-style-type: none"> <li>Any door open → all door close</li> <li>Press ignition knob switch: ON (Ignition knob switch)</li> </ul>		
14	BR	Instrument panel antenna (-) signal				
15	SB	Front console antenna (+) signal	LOCK	<ul style="list-style-type: none"> <li>Any door open → all door close</li> <li>Press ignition knob switch: ON (Ignition knob switch)</li> </ul>		
16	O	Front console antenna (-) signal				



# INTELLIGENT KEY SYSTEM

## < SERVICE INFORMATION >

Terminal	Wire Color	Item	Condition		Voltage (V) Approx.
			Ignition Switch Position	Operation or Conditions	
17	W	Rear bumper antenna (+) signal	LOCK	Press back door request switch.	<p style="text-align: right; font-size: small;">SIA1910J</p>
18	R	Rear bumper antenna (-) signal			
19	V	Front outside antenna LH (+) signal	LOCK	Press door request switch LH.	<p style="text-align: right; font-size: small;">SIA1910J</p>
20	O	Front outside antenna LH (-) signal			
25	GR	Front door request switch RH	—	Press front door request switch RH.	0
				Other than above	5
27	O	Ignition knob switch	—	Press ignition switch.	Battery voltage
				Release ignition switch.	0
28	LG	Unlock sensor (driver side)	—	Door (driver side) is locked.	5
				Door (driver side) is unlocked.	0
29	P	Trunk opener	—	Press trunk opener request switch.	0
				Other than above	5
31	G	Steering lock solenoid ground	—	—	0
32	L	Steering lock solenoid communication signal	LOCK	When Intelligent Key is inside vehicle, press ignition knob switch.	<p style="text-align: right; font-size: small;">SIA1911J</p>
				Other than above	5
33	Y	Rear parcel shelf antenna (+) signal	LOCK	<ul style="list-style-type: none"> <li>• Any door open → all door close</li> <li>• Press ignition knob switch: ON (Ignition knob switch)</li> </ul>	<p style="text-align: right; font-size: small;">PIB5502J</p>
34	V	Rear parcel shelf antenna (-) signal			
37	G	Front outside antenna RH (+) signal	LOCK	Press door request switch RH.	<p style="text-align: right; font-size: small;">SIA1910J</p>
38	SB	Front outside antenna RH (-) signal			

A  
B  
C  
D  
E  
F  
G  
H  
BL  
J  
K  
L  
M  
N  
O  
P

# INTELLIGENT KEY SYSTEM

## < SERVICE INFORMATION >

Terminal	Wire Color	Item	Condition		Voltage (V) Approx.
			Ignition Switch Position	Operation or Conditions	
40	GR	AS unlock output	—	Unlock with rear door locks disabled.	0
				Other than above	Battery voltage

## Steering Lock Solenoid Harness Connector Terminal Layout

INFOID:000000004407727

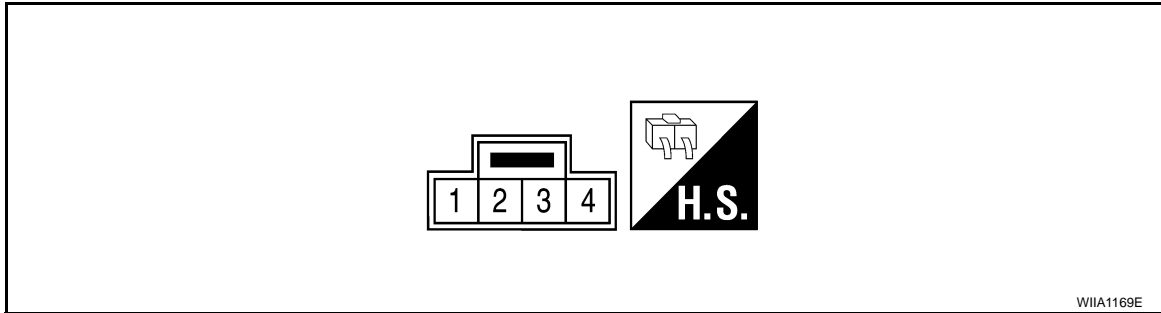

## Terminal and Reference Value for Steering Lock Solenoid

INFOID:000000004407728

Terminal	Wire Color	Signal Designation	Condition		Voltage (V) Approx.
			Ignition Switch Position	Operation or Conditions	
1	SB	Power source (fuse)	LOCK	—	Battery voltage
2	LG	Steering lock solenoid power supply	LOCK	—	5
3	L	Steering lock solenoid communication signal	LOCK	When Intelligent Key is inside vehicle, press ignition knob switch.	
				Other than the above	5
4	G	Steering lock solenoid ground	—	—	0

## Terminal and Reference Value for BCM

INFOID:000000004407729

Refer to [BCS-11, "Terminal and Reference Value for BCM"](#).

## Terminal and Reference Value for IPDM E/R

INFOID:000000004407730

Refer to [PG-24, "Terminal and Reference Value for IPDM E/R"](#).

## Terminal and Reference Value for Combination Meter

INFOID:000000004407731

Refer to [DI-12, "Terminal and Reference Value for Combination Meter"](#).

## Trouble Diagnosis Procedure

INFOID:000000004407732

## PRELIMINARY CHECK

# INTELLIGENT KEY SYSTEM

## < SERVICE INFORMATION >

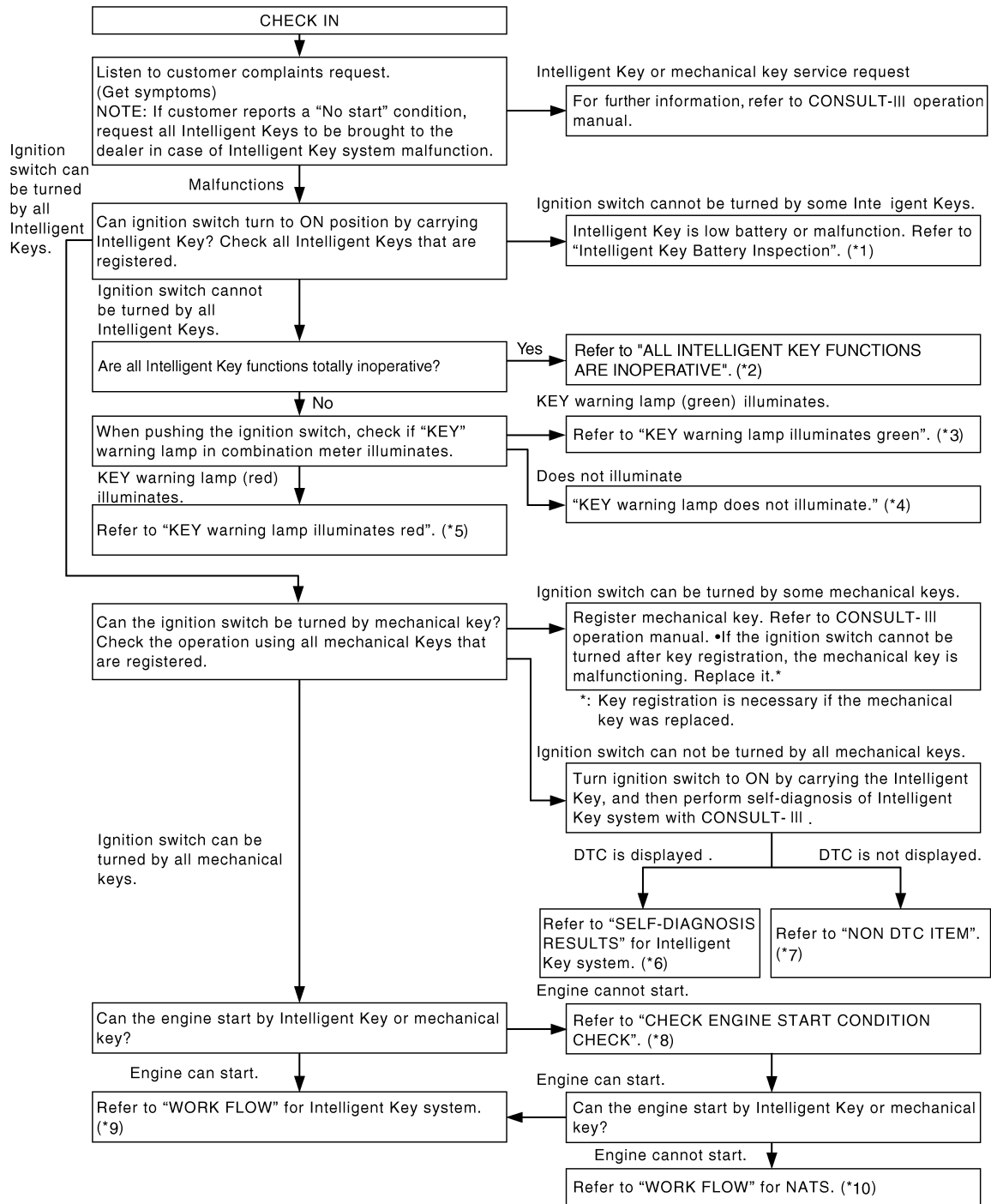

WIIA1362E

\*1: [BL-128](#)

\*4: [BL-99](#)

\*7: [BL-99](#)

\*10: "WORK FLOW"

\*2: [BL-99](#)

\*5: [BL-99](#)

\*8: [BL-99](#)

\*3: [BL-99](#)

\*6: [BL-97](#)

\*9: "WORK FLOW"

## WORK FLOW

# INTELLIGENT KEY SYSTEM

## < SERVICE INFORMATION >

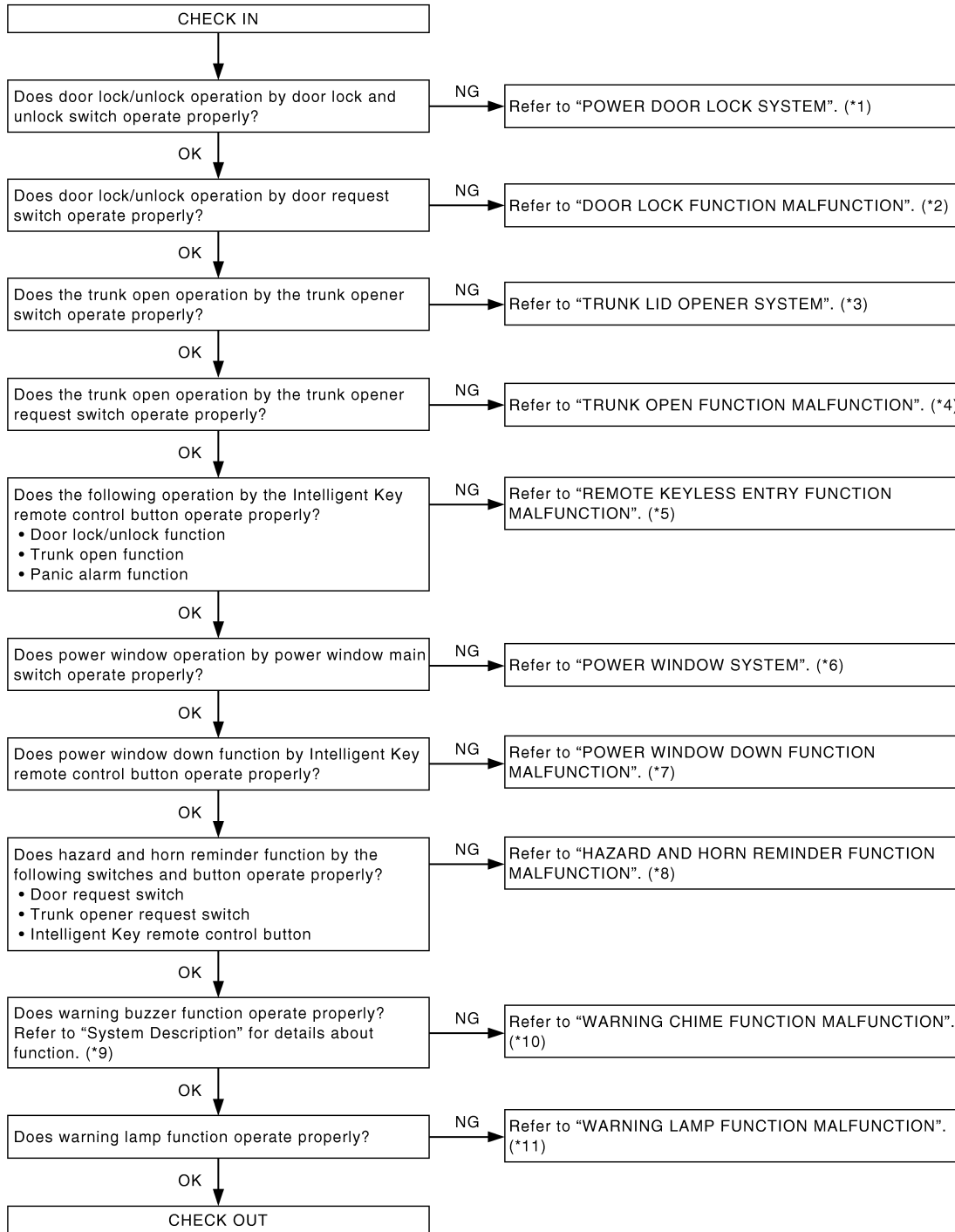

PIIB4186E

\*1: [BL-20](#)

\*4: [BL-99](#)

\*7: [BL-99](#)

\*10: [BL-99](#)

\*2: [BL-99](#)

\*5: [BL-99](#)

\*8: [BL-99](#)

\*11: [BL-99](#)

\*3: [BL-144](#)

\*6: [GW-15](#)

\*9: [BL-72](#)

## CONSULT-III Function (INTELLIGENT KEY)

INFOID:000000004407733

CONSULT-III can display each diagnostic item using the diagnostic test modes as shown below.

# INTELLIGENT KEY SYSTEM

## < SERVICE INFORMATION >

Part to be diagnosed	Test item, Diagnosis mode	Description
Intelligent Key	WORK SUPPORT	Changes settings for each function.
	SELF-DIAG RESULTS	Intelligent Key unit performs CAN communication diagnosis.
	DATA MONITOR	Displays Intelligent Key unit input data in real time.
	CAN DIAG SUPPORT MONITOR	The results of transmit/receive diagnosis of CAN Communication can be read.
	ACTIVE TEST	Operation of electrical loads can be checked by sending driving signal to then.
	ECU PART NUMBER	Displays Intelligent Key unit part No.

## BASIC OPERATION

INFOID:000000004407734

1. Connect CONSULT-III.

### NOTE:

Use mechanical key to turn ignition switch to ON.

2. Perform "SELF-DIAG RESULTS".

## CONSULT-III Application Item

INFOID:000000004407735

## SELF-DIAGNOSTIC RESULTS

Self-diag results	Description	Diagnosis procedure	Reference page
CAN COMM	Malfunction is detected in CAN communication.	CAN communication system check.	<a href="#">LAN-9</a>
CAN COMM2	Intelligent Key unit internal malfunction	CAN communication system check.	<a href="#">LAN-9</a>
STRG COMM	Malfunction is detected in communication of Intelligent Key unit and steering lock solenoid.	Steering lock solenoid check.	<a href="#">BL-122</a>
I-KEY C/U	Intelligent Key unit internal malfunction	Replace Intelligent Key unit.	<a href="#">BL-129</a>
IMMU	NATS malfunction	Check NATS.	<a href="#">BL-170</a>

## WORK SUPPORT

Monitor item	Description
CONFIRM KEY FOB ID	It can be checked whether Intelligent Key ID code is registered or not in this mode.
TAKE OUT FROM WINDOW WARN	Take away warning chime (from window) mode can be changed to operate (ON) or not operate (OFF) with this mode. The operation mode will be changed when "CHANGE SETT" on CONSULT-III screen is touched.
LOW BAT OF KEY FOB WARN	Intelligent Key low battery warning mode can be changed to operate (ON) or not operate (OFF) with this mode. The operation mode will be changed when "CHANGE SETT" on CONSULT-III screen is touched.
ANSWER BACK FUNCTION	The condition of answer back function can be changed to operate (ON) or not operate (OFF) with this mode. The operation mode will be changed when "CHANGE SETT" on CONSULT-III screen is touched.
SELECTIVE UNLOCK FUNCTION	Selective unlock function mode can be changed to operate (ON) or not operate (OFF) with this mode. The operation mode will be changed when "CHANGE SETT" on CONSULT-III screen is touched.
ANTI KEY LOCK IN FUNCTION	Key reminder function mode can be changed to operate (ON) or not operate (OFF) with this mode. The operation mode will be changed when "CHANGE SETT" on CONSULT-III screen is touched.
HORN WITH KEYLESS LOCK	Horn reminder function mode by Intelligent Key remote control button can be changed to operate (ON) or not operate (OFF) with this mode. The operation mode will be changed when "CHANGE SETT" on CONSULT-III screen is touched.

# INTELLIGENT KEY SYSTEM

## < SERVICE INFORMATION >

Monitor item	Description
HAZARD ANSWER BACK	<p>Hazard reminder function mode can be selected from the following with this mode. The operation mode will be changed when "CHANGE SETT" on CONSULT-III screen is touched.</p> <ul style="list-style-type: none"> <li>• LOCK ONLY: Door lock operation only</li> <li>• UNLOCK ONLY: Door unlock operation only</li> <li>• LOCK/UNLOCK: Lock/Unlock operation</li> <li>• OFF: Non-operation</li> </ul>
ANSWER BACK WITH I-KEY LOCK	<p>Horn reminder function (lock operation) mode by any front door request or trunk opener request switch can be selected from the following with this mode. The operation mode will be changed when "CHANGE SETT" on CONSULT-III screen is touched.</p> <ul style="list-style-type: none"> <li>• HORN CHIRP: Sound horn</li> <li>• BUZZER: Sound buzzer</li> <li>• OFF: Non-operation</li> </ul>
ANSWER BACK WITH I-KEY UNLOCK	<p>Horn reminder function (unlock operation) mode by a door request switch can be changed to operate (ON) or not operate (OFF) with this mode.</p>
AUTO RELOCK TIMER	<p>Auto door lock timer mode can select the following with this mode.</p> <ul style="list-style-type: none"> <li>• 1 minute</li> <li>• 5 minute</li> <li>• OFF: Non-operation</li> </ul>
PANIC ALARM DELAY	<p>Panic alarm button's pressing time on Intelligent Key remote control button can be selected from the following with this mode. The operation mode will be changed when "CHANGE SETT" on CONSULT-III screen is touched.</p> <ul style="list-style-type: none"> <li>• 0.5 second</li> <li>• 1.5 second</li> <li>• No delay</li> </ul>
TRUNK/GLASS HATCH OPEN	<p>Hazard and horn reminder function mode by trunk request switch can be changed to operate (ON) or not operate (OFF) with this mode. The operation mode will be changed when "CHANGE SETT" on CONSULT-III screen is touched.</p>
TRUNK OPEN DELAY	<p>Trunk button's pressing time on Intelligent Key remote control button can be selected from the following with this mode. The operation mode will be changed when "CHANGE SETT" on CONSULT-III screen is touched.</p> <ul style="list-style-type: none"> <li>• 0.5 second</li> <li>• 1.5 second</li> <li>• No delay</li> </ul>
LOCK/UNLOCK BY I-KEY	<p>Door lock/unlock function by any front door request or trunk opener request switch mode can be changed to operate (ON) or not operate (OFF) with this mode. The operation mode will be changed when "CHANGE SETT" on CONSULT-III screen is touched.</p>

## DATA MONITOR

Monitor item	Content
PUSH SW	Indicates [ON/OFF] condition of ignition knob switch.
KEY SW	Indicates [ON/OFF] condition of key switch.
DR REQ SW	Indicates [ON/OFF] condition of front door request switch LH.
AS REQ SW	Indicates [ON/OFF] condition of front door request switch RH.
BD/TR REQ SW	Indicates [ON/OFF] condition of trunk opener request switch.
IGN SW	Indicates [ON/OFF] condition of ignition switch in ON position.
ACC SW	Indicates [ON/OFF] condition of ignition switch in ACC position.
STOP LAMP SW	Indicates [ON/OFF] condition of stop lamp switch.
P RANGE SW	Indicates [ON/OFF] condition of CVT device (park position switch).
DOOR LOCK SIG*	Indicates [ON/OFF] condition of door lock signal from Intelligent Key remote control button.
DOOR UNLOCK SIG*	Indicates [ON/OFF] condition of door unlock signal from Intelligent Key remote control button.
KEYLESS TRUNK*	Indicates [ON/OFF] condition of trunk open signal from Intelligent Key remote control button.
KEYLESS PANIC*	Indicates [ON/OFF] condition of panic alarm signal from Intelligent Key remote control button.
DOOR SW DR*	Indicates [OPEN/CLOSE] condition of front door switch driver side from BCM via CAN communication line.

# INTELLIGENT KEY SYSTEM

## < SERVICE INFORMATION >

Monitor item	Content
DOOR SW AS*	Indicates [OPEN/CLOSE] condition of front door switch passenger side from BCM via CAN communication line.
DOOR SW RR*	Indicates [OPEN/CLOSE] condition of RR door switch from BCM via CAN communication line.
DOOR SW RL*	Indicates [OPEN/CLOSE] condition of RL door switch from BCM via CAN communication line.
TRUNK SW*	Indicates [OPEN/CLOSE] condition of trunk lamp switch from BCM via CAN communication line.
VEHICLE SPEED*	Indicates [km/h] condition of vehicle speed.

\*: Select "SELECTION FROM MENU".

## ACTIVE TEST

Test item	Description
DOOR LOCK/UNLOCK	<p>This test is able to check door lock/unlock operation.</p> <ul style="list-style-type: none"> <li>The all door lock actuators are unlocked when "ALL UNLK" on CONSULT-III screen is touched.</li> <li>The door lock actuator (driver side) is unlocked when "DR UNLK" on CONSULT-III screen is touched.</li> <li>The door lock actuator (passenger side) is unlocked when "AS UNLK" on CONSULT- III screen is touched.</li> <li>The all door lock actuators are locked when "LOCK" on CONSULT-III screen is touched.</li> </ul>
ANTENNA	<p>This test is able to check Intelligent Key antenna operation. When the following conditions are met, hazard warning lamps flash.</p> <ul style="list-style-type: none"> <li>Inside key antenna (Instrument panel) detects Intelligent Key, when "RM ANT1" on CONSULT-III screen is touched.</li> <li>Inside key antenna (Front console) detects Intelligent Key, when "RM ANT2" on CONSULT-III screen is touched.</li> <li>Inside key antenna (Trunk room) detects Intelligent Key, when "LAG ANT" on CONSULT-III screen is touched.</li> <li>Outside key antenna (LH side) detects Intelligent Key, when "DR ANT" on CONSULT-III screen is touched.</li> <li>Outside key antenna (RH side) detects Intelligent Key, when "AS ANT" on CONSULT-III screen is touched.</li> <li>Rear bumper antenna detects Intelligent Key, when "BD ANT" on CONSULT-III screen is touched.</li> </ul>
OUTSIDE BUZZER	<p>This test is able to check Intelligent Key warning buzzer (front of vehicle) operation. Intelligent Key warning buzzer (front of vehicle) sounds when "ON" on CONSULT-III screen is touched.</p>
INSIDE BUZZER (CHIME)	<p>This test is able to check Intelligent Key warning chime (combination meter) operation.</p> <ul style="list-style-type: none"> <li>Take away warning chime sounds when "TAKE OUT" on CONSULT-III screen is touched.</li> <li>Ignition switch warning chime sounds when "KNOB" on CONSULT-III screen is touched.</li> <li>Ignition key warning chime sounds when "KEY" on CONSULT-III screen is touched.</li> </ul>
INDICATOR	<p>This test is able to check warning lamp operation.</p> <ul style="list-style-type: none"> <li>"KEY" Warning lamp (Green) illuminates when "BLUE ON" on CONSULT-III screen is touched.</li> <li>"KEY" Warning lamp (Red) illuminates when "RED ON" on CONSULT-III screen is touched.</li> <li>"P-SHIFT" Warning lamp illuminates when "KNOB ON" on CONSULT-III screen is touched.</li> <li>"KEY" Warning lamp (Green) flashes when "BLUE IND" on CONSULT-III screen is touched.</li> <li>"KEY" Warning lamp (RED) flashes when "BLUE IND" on CONSULT-III screen is touched.</li> <li>"P-SHIFT" Warning lamp flashes when "KNOB ON" on CONSULT-III screen is touched.</li> </ul>

## Trouble Diagnosis Symptom Chart

INFOID:000000004407736

### ALL INTELLIGENT KEY FUNCTIONS ARE INOPERATIVE

#### NOTE:

- Before performing the diagnosis in the following table, check "Trouble Diagnosis Procedure". Refer to [BL-94, "Trouble Diagnosis Procedure"](#).
- Make sure that vehicle is under the condition shown in "Conditions of vehicle" before starting diagnosis, and check each symptom.
- If the following "symptoms" are detected, check systems shown in the "Diagnoses/service procedure" column in this order.
- Check if ignition switch turns using mechanical key. If it turns, check if "ENGINE START BY I-KEY" in "WORK SUPPORT" mode is ON.

# INTELLIGENT KEY SYSTEM

## < SERVICE INFORMATION >

### Conditions of Vehicle (Operating Conditions)

- Intelligent Key is registered.
- Key is not inserted in ignition switch.
- One or more registered Intelligent Keys are in the vehicle.

Symptom	Diagnosis/service procedure	Reference page
All doors, trunk and ignition switch do not respond to Intelligent Key command.	1. Intelligent Key battery inspection check.	<a href="#">BL-128</a>
	2. Remote Keyless Entry Function check.	<a href="#">BL-128</a>
	3. Intelligent Key unit power supply and ground circuit check.	<a href="#">BL-106</a>
	4. Replace Intelligent Key unit.	<a href="#">BL-129</a>

### KEY WARNING LAMP (GREEN) ILLUMINATES

#### NOTE:

- Before performing the diagnosis in the following table, check “Trouble Diagnosis Procedure”. Refer to [BL-94, "Trouble Diagnosis Procedure"](#).
- Make sure that vehicle is under the condition shown in “Conditions of vehicle” before starting diagnosis, and check each symptom.
- If the following “symptoms” are detected, check systems shown in the “Diagnoses/service procedure” column in this order.

### Conditions of Vehicle (Operating Conditions)

- Intelligent Key is registered.
- Key is not inserted in ignition switch.
- One or more registered Intelligent Keys are in the vehicle.

Symptom	Diagnosis/service procedure	Reference page
Ignition switch does not turn on with Intelligent Key. [KEY warning lamp (green) illuminates].	1. Steering lock solenoid check.	<a href="#">BL-122</a>
	2. Replace Intelligent Key unit.	<a href="#">BL-129</a>

### KEY WARNING LAMP (RED) ILLUMINATES

#### NOTE:

- Before performing the diagnosis in the following table, check “Trouble Diagnosis Procedure”. Refer to [BL-94, "Trouble Diagnosis Procedure"](#).
- Make sure that vehicle is under the condition shown in “Conditions of vehicle” before starting diagnosis, and check each symptom.
- If the following “symptoms” are detected, check systems shown in the “Diagnoses/service procedure” column in this order.

### Conditions of Vehicle (Operating Conditions)

- Intelligent Key is registered.
- Key is not inserted in ignition switch.
- One or more registered Intelligent Keys are in the vehicle.

Symptom	Diagnosis/service procedure	Reference page
Ignition switch does not turn on with Intelligent Key. [KEY warning lamp (red) illuminates].	1. Inside key antenna check.	<a href="#">BL-120</a>
	2. Replace Intelligent Key unit.	<a href="#">BL-129</a>

### KEY WARNING LAMP DOES NOT ILLUMINATE

#### NOTE:

- Before performing the diagnosis in the following table, check “Trouble Diagnosis Procedure”. Refer to [BL-94, "Trouble Diagnosis Procedure"](#).
- Make sure that vehicle is under the condition shown in “Conditions of vehicle” before starting diagnosis, and check each symptom.
- If the following “symptoms” are detected, check systems shown in the “Diagnoses/service procedure” column in this order.
- Check if ignition switch turns using mechanical key. If it turns, check if “ENGINE START BY I-KEY” in “WORK SUPPORT” mode is ON.

### Conditions of Vehicle (Operating Conditions)



# INTELLIGENT KEY SYSTEM

## < SERVICE INFORMATION >

- Intelligent Key is registered.
- Key is not inserted in ignition switch.
- One or more registered Intelligent Keys are in the vehicle.

Symptom	Diagnosis/service procedure	Reference page
Ignition switch does not turn on with Intelligent Key. [KEY warning lamp does not illuminate].	1. Intelligent Key unit power supply and ground circuit check.	<a href="#">BL-106</a>
	2. Ignition knob switch check.	<a href="#">BL-109</a>
	3. Key switch check.	<a href="#">BL-107</a>
	4. Replace Intelligent Key unit.	<a href="#">BL-129</a>

## NON DTC ITEM

### NOTE:

- Before performing the diagnosis in the following table, check “Trouble Diagnosis Procedure”. Refer to [BL-94, "Trouble Diagnosis Procedure"](#).
- Make sure that vehicle is under the condition shown in “Conditions of vehicle” before starting diagnosis, and check each symptom.
- If the following “symptoms” are detected, check systems shown in the “Diagnoses/service procedure” column in this order.

### Conditions of Vehicle (Operating Conditions)

- Intelligent Key is registered.
- Multiple mechanical keys are not set in a keyfob.  
(If mechanical keys are near the ignition switch, the operation may not work properly).

Symptom	Diagnosis/service procedure	Reference page
Non DTC Item	1. Key switch check.	<a href="#">BL-107</a>
	2. NATS antenna amp. check	<a href="#">BL-173</a>

## ENGINE START CONDITION CHECK

### NOTE:

- Before performing the diagnosis in the following table, check “Trouble Diagnosis Procedure”. Refer to [BL-94, "Trouble Diagnosis Procedure"](#).
- If the following “symptoms” are detected, check systems shown in the “Diagnoses/service procedure” column in this order.

Symptom	Diagnosis/service procedure	Reference page
Engine start condition check	1. CVT device (park position switch) check.	<a href="#">BL-125</a>
	2. Stop lamp switch check.	<a href="#">BL-123</a>
	3. Replace Intelligent Key unit.	<a href="#">BL-129</a>

## DOOR LOCK/UNLOCK FUNCTION MALFUNCTION

### NOTE:

- Before performing the diagnosis in the following table, check “Trouble Diagnosis Procedure”. Refer to [BL-94, "Trouble Diagnosis Procedure"](#).
- Make sure that vehicle is under the condition shown in “Conditions of vehicle” before starting diagnosis, and check each symptom.
- If the following “symptoms” are detected, check systems shown in the “Diagnosis/procedure” column in this order.

### Conditions of Vehicle (Operating Conditions)

- “LOCK/UNLOCK BY I-KEY” is ON when setting on CONSULT-III.
- Ignition switch is not depressed.
- All doors are closed.

# INTELLIGENT KEY SYSTEM

## < SERVICE INFORMATION >

Symptom	Diagnosis/service procedure	Reference page
Door lock/unlock do not operate by request switch.	1. Door switch check.	<a href="#">BL-110</a>
	2. Ignition knob switch check.	<a href="#">BL-109</a>
	3. Replace Intelligent Key unit.	<a href="#">BL-129</a>
Door lock/unlock does not operate by request switch (LH side).	1. Front door request switch LH check.	<a href="#">BL-113</a>
	2. Front outside antenna LH check.	<a href="#">BL-119</a>
	3. Replace Intelligent Key unit.	<a href="#">BL-129</a>
Door lock/unlock does not operate by request switch (RH side).	1. Front door request switch RH check.	<a href="#">BL-113</a>
	2. Front outside antenna RH check.	<a href="#">BL-119</a>
	3. Replace Intelligent Key unit.	<a href="#">BL-129</a>
Selective unlock function does not operate by front door request switch LH (other door lock functions operate properly).	1. Check "SELECT UNLOCK FUNCTION" setting in "WORK SUPPORT".	<a href="#">BL-97</a>
	2. Replace Intelligent Key unit.	<a href="#">BL-129</a>
Auto lock function does not operate properly.	1. Check "AUTO RELOCK TIMER" setting in "WORK SUPPORT".	<a href="#">BL-97</a>
	2. Key switch check.	<a href="#">BL-107</a>
	3. Ignition knob switch check.	<a href="#">BL-109</a>
	4. Door switch check.	<a href="#">BL-110</a>
	5. Replace Intelligent Key unit.	<a href="#">BL-129</a>
Key reminder function does not operate properly.	1. Check "ANTI KEY LOCK IN FUNCTION" setting in "WORK SUPPORT".	<a href="#">BL-97</a>
	2. Door switch check.	<a href="#">BL-110</a>
	3. Inside key antenna check.	<a href="#">BL-120</a>
	4. Front door lock actuator LH (door unlock sensor) check.	<a href="#">BL-117</a>
	5. Intelligent Key battery inspection.	<a href="#">BL-128</a>
	6. Replace Intelligent Key unit.	<a href="#">BL-129</a>

### REMOTE KEYLESS ENTRY FUNCTION MALFUNCTION

**NOTE:**

- Before performing the diagnosis in the following table, check "Trouble Diagnosis Procedure". Refer to [BL-94](#), "[Trouble Diagnosis Procedure](#)".
- Make sure that vehicle is under the condition shown in "Conditions of vehicle" before starting diagnosis, and check each symptom.
- If the following "symptoms" are detected, check systems shown in the "Diagnosis/service procedure" column in this order.

Conditions of Vehicle (Operating Conditions)

- Ignition switch is not depressed.
- All doors are closed.

Symptom	Diagnosis/service procedure	Reference page
All of the remote keyless entry functions do not operate.	1. Intelligent Key battery and function inspection.	<a href="#">BL-128</a>
	2. Remote Keyless Entry function check.	<a href="#">BL-128</a>
	3. Replace Intelligent Key unit.	<a href="#">BL-129</a>
Selective unlock function does not operate by Intelligent Key remote control button.	1. Check "SELECT UNLOCK FUNCTION" setting in "WORK SUPPORT".	<a href="#">BL-97</a>
	2. Intelligent Key battery inspection.	<a href="#">BL-128</a>
	3. Replace Intelligent Key unit.	<a href="#">BL-129</a>

# INTELLIGENT KEY SYSTEM

## < SERVICE INFORMATION >

Symptom	Diagnosis/service procedure	Reference page
Auto lock function does not operate properly.	1. Check "AUTO RELOCK TIMER" setting in "WORK SUPPORT".	<a href="#">BL-97</a>
	2. Key switch check.	<a href="#">BL-107</a>
	3. Ignition knob switch check.	<a href="#">BL-109</a>
	4. Door switch check.	<a href="#">BL-110</a>
	5. Replace Intelligent Key unit.	<a href="#">BL-129</a>
Key reminder function does not operate properly.	1. Check "ANTI KEY LOCK IN FUNCTION" setting in "WORK SUPPORT".	<a href="#">BL-97</a>
	2. Door switch check.	<a href="#">BL-110</a>
	3. Inside key antenna check.	<a href="#">BL-120</a>
	4. Front door lock actuator LH (door unlock sensor) check.	<a href="#">BL-117</a>
	5. Intelligent Key battery inspection.	<a href="#">BL-128</a>
	6. Replace Intelligent Key unit.	<a href="#">BL-129</a>
Panic alarm function does not operate properly.	1. Check "PANIC ALARM DELAY" setting in "WORK SUPPORT".	<a href="#">BL-97</a>
	2. Theft warning operation check.	<a href="#">BL-153</a>
	3. Intelligent Key battery inspection.	<a href="#">BL-128</a>
	4. Key switch check.	<a href="#">BL-107</a>
	5. Ignition knob switch check.	<a href="#">BL-109</a>
	6. Replace Intelligent Key unit.	<a href="#">BL-129</a>
Trunk open function does not operate properly.	1. Check "TRUNK OPEN DELAY" setting in "WORK SUPPORT".	<a href="#">BL-97</a>
	2. Trunk lid opener system check.	<a href="#">BL-144</a>
	3. Trunk lamp switch check.	<a href="#">BL-112</a>
	4. Intelligent Key battery inspection.	<a href="#">BL-128</a>
	5. Replace Intelligent Key unit.	<a href="#">BL-129</a>

### TRUNK OPEN FUNCTION MALFUNCTION

**NOTE:**

- Before performing the diagnosis in the following table, check "Trouble Diagnosis Procedure". Refer to [BL-94, "Trouble Diagnosis Procedure"](#).
- Make sure that vehicle is under the condition shown in "Conditions of vehicle" before starting diagnosis, and check each symptom.
- If the following "symptoms" are detected, check systems shown in the "Diagnosis/service procedure" column in this order.

Conditions of Vehicle (Operating Conditions)

- "LOCK/UNLOCK BY I-KEY" is ON when setting on CONSULT-III.
- Trunk cancel switch is in ON position.

Symptom	Diagnosis procedure	Reference page
Trunk open function does not operate by trunk opener request switch.	1. Trunk opener request switch check.	<a href="#">BL-115</a>
	2. Rear bumper antenna check.	<a href="#">BL-119</a>
	3. Replace Intelligent Key unit.	<a href="#">BL-129</a>

### HAZARD AND HORN REMINDER FUNCTION MALFUNCTION

**NOTE:**

- Before performing the diagnosis in the following table, check "Trouble Diagnosis Procedure". Refer to [BL-94, "Trouble Diagnosis Procedure"](#).
- Make sure that vehicle is under the condition shown in "Conditions of vehicle" before starting diagnosis, and check each symptom.
- If the following "symptoms" are detected, check systems shown in the "Diagnosis/service procedure" column in this order.

Conditions of Vehicle (Operating Conditions)

# INTELLIGENT KEY SYSTEM

## < SERVICE INFORMATION >

- Ignition switch is not depressed.
- All doors are closed.

Symptom	Diagnosis/service procedure	Reference page
Hazard reminder does not operate properly by request switch. (Horn reminder operates properly).	1. Check "HAZARD ANSWER BACK" setting in "WORK SUPPORT".	<a href="#">BL-97</a>
	2. Hazard function with hazard switch check.	<a href="#">BL-127</a>
	3. Replace Intelligent Key unit	<a href="#">BL-129</a>
Horn reminder does not operate properly by request switch. (Hazard reminder operates properly).	1. Check "ANSWER BACK WITH I-KEY LOCK" or "ANSWER BACK WITH I-KEY UNLOCK" setting in "WORK SUPPORT".	<a href="#">BL-97</a>
	2. Intelligent Key warning buzzer (front of vehicle) check.	<a href="#">BL-118</a>
	3. Horn function check.	<a href="#">BL-127</a>
	4. IPDM E/R operation check.	<a href="#">BL-127</a>
	5. Replace Intelligent Key unit.	<a href="#">BL-129</a>
Hazard reminder does not operate properly by Intelligent Key remote control button. (Horn reminder operates properly).	1. Check "HAZARD ANSWER BACK" setting in "WORK SUPPORT".	<a href="#">BL-97</a>
	2. Hazard function check.	<a href="#">BL-127</a>
	3. Replace Intelligent Key unit.	<a href="#">BL-129</a>
Horn reminder does not operate properly by Intelligent Key remote control button (door lock/unlock button). (Hazard reminder operates properly).	1. Check "HORN WITH KEYLESS LOCK" setting in "WORK SUPPORT".	<a href="#">BL-97</a>
	2. Intelligent Key warning buzzer (front of vehicle) check.	<a href="#">BL-118</a>
	3. Horn function check.	<a href="#">BL-127</a>
	4. IPDM E/R operation check.	<a href="#">BL-127</a>
	5. Replace Intelligent Key unit.	<a href="#">BL-129</a>
Horn reminder does not operate properly by trunk opener request switch.	1. Check "TRUNK/GLASS HATCH OPEN" setting in "WORK SUPPORT".	<a href="#">BL-97</a>
	2. Intelligent Key warning buzzer (front of vehicle) check.	<a href="#">BL-118</a>
	3. Lid trunk opener system check.	<a href="#">BL-144</a>
	4. Replace Intelligent Key unit.	<a href="#">BL-129</a>

## WARNING CHIME FUNCTION MALFUNCTION

### NOTE:

- Before performing the diagnosis in the following table, check "Trouble Diagnosis Procedure". Refer to [BL-94](#), "[Trouble Diagnosis Procedure](#)".
- Make sure that vehicle is under the condition shown in "Conditions of vehicle" before starting diagnosis, and check each symptom.
- If the following "symptoms" are detected, check systems shown in the "Diagnosis/service procedure" column in this order.

### Conditions of Vehicle (Operating Conditions)

Each warning chime function is ON when setting on CONSULT-III.

Symptom	Diagnosis/service procedure	Reference page
Ignition switch warning chime does not operate.	1. Ignition knob switch check.	<a href="#">BL-109</a>
	2. Door switch check.	<a href="#">BL-110</a>
	3. Key switch check.	<a href="#">BL-107</a>
	4. Intelligent Key warning chime (combination meter) check.	<a href="#">BL-118</a>
	5. Replace Intelligent Key unit.	<a href="#">BL-129</a>

# INTELLIGENT KEY SYSTEM

## < SERVICE INFORMATION >

Symptom	Diagnosis/service procedure	Reference page
Ignition key warning chime does not operate properly. (When mechanical key is used)	1. Key switch (Intelligent Key unit input) check.	<a href="#">BL-107</a>
	2. Key switch (BCM input) check.	<a href="#">BL-108</a>
	3. Door switch check.	<a href="#">BL-110</a>
	4. Warning chime check.	<a href="#">BL-118</a>
	5. Replace Intelligent Key unit.	<a href="#">BL-129</a>
OFF position warning chime does not operate.	1. Ignition knob switch check.	<a href="#">BL-109</a>
	2. Key switch check.	<a href="#">BL-107</a>
	3. Power supply and ground circuit check.	<a href="#">BL-106</a>
	4. Intelligent Key warning chime (combination meter) check.	<a href="#">BL-118</a>
	5. Replace Intelligent Key unit.	<a href="#">BL-129</a>
OFF position warning chime (after door closed) does not operate properly.	1. Ignition knob switch check.	<a href="#">BL-109</a>
	2. Intelligent Key warning buzzer (front of vehicle) check.	<a href="#">BL-118</a>
	3. Replace Intelligent Key unit.	<a href="#">BL-129</a>
Take away warning chime does not operate properly.	1. Door switch check.	<a href="#">BL-110</a>
	2. Power supply and ground circuit check.	<a href="#">BL-106</a>
	3. Intelligent Key battery inspection.	<a href="#">BL-128</a>
	4. Inside key antenna check.	<a href="#">BL-120</a>
	5. Intelligent Key warning buzzer (front of vehicle) check.	<a href="#">BL-118</a>
	6. Replace Intelligent Key unit.	<a href="#">BL-129</a>
Take away warning chime (from window) does not operate properly.	1. Check "TAKE OUT FROM WINDOW WARN" setting in "WORK SUPPORT".	<a href="#">BL-97</a>
	2. Inside key antenna check.	<a href="#">BL-120</a>
	3. Power supply and ground circuit check	<a href="#">BL-106</a>
	4. Intelligent Key battery inspection.	<a href="#">BL-128</a>
	5. Intelligent Key warning chime (combination meter) check.	<a href="#">BL-118</a>
	6. Replace Intelligent Key unit.	<a href="#">BL-129</a>
Door lock operation warning chime does not operate properly.	1. Door switch check.	<a href="#">BL-110</a>
	2. Ignition knob switch check.	<a href="#">BL-109</a>
	3. Front door request switch LH check.	<a href="#">BL-113</a>
	4. Front outside antenna LH check.	<a href="#">BL-119</a>
	5. Inside key antenna check.	<a href="#">BL-120</a>
	6. Intelligent Key warning buzzer (front of vehicle) check.	<a href="#">BL-118</a>
	7. Replace Intelligent Key unit.	<a href="#">BL-129</a>

### WARNING LAMP FUNCTION MALFUNCTION

#### NOTE:

- Before performing the diagnosis in the following table, check "Trouble Diagnosis Procedure". Refer to [BL-94](#), "[Trouble Diagnosis Procedure](#)".
- If the following "symptoms" are detected, check systems shown in the "Diagnosis/service procedure" column in this order.

Symptom	Diagnosis/service procedure	Reference page
Intelligent Key low battery warning does not operate properly.	1. Check "LOW BAT OF KEY FOB WARN" setting in "WORK SUPPORT".	<a href="#">BL-97</a>
	2. Intelligent Key battery inspection.	<a href="#">BL-128</a>
	3. KEY warning lamp (green) check.	<a href="#">BL-126</a>
	4. Replace Intelligent Key unit.	<a href="#">BL-129</a>

# INTELLIGENT KEY SYSTEM

## < SERVICE INFORMATION >

Symptom	Diagnosis/service procedure	Reference page
P position warning lamp does not illuminate properly.	1. CVT device (park position switch) check.	<a href="#">BL-125</a>
	2. "P-SHIFT" warning lamp (red) check.	<a href="#">BL-126</a>
	3. Replace Intelligent Key unit.	<a href="#">BL-129</a>
Take away warning lamp does not illuminate properly. (Take away warning chime is operated).	1. KEY warning lamp (red) check.	<a href="#">BL-126</a>
	2. Replace Intelligent Key unit.	<a href="#">BL-129</a>
Ignition switch warning lamp does not illuminate properly. (Ignition switch warning chime is operated).	1. KEY warning lamp (red) check.	<a href="#">BL-126</a>
	2. Replace Intelligent Key unit.	<a href="#">BL-129</a>

## CAN Communication System Inspection

INFOID:000000004407737

### 1.CHECK SELF-DIAGNOSTIC RESULTS

#### With CONSULT-III

- Connect CONSULT-III, and turn ignition switch ON.
- Touch "INTELLIGENT KEY" on "SELECT SYSTEM" screen.
- Touch "SELF-DIAG RESULTS" on "SELECT DIAG MODE" screen.
- Check display content in self-diagnostic results.

CONSULT-III display item	DTC code
NO DTC IS DETECTED	—
CAN COMM	U1000
CAN COMM2	U1010

#### OK or NG

NO DTC IS DETECTED>> INSPECTION END

CAN COMM [U1000]>> Go to "CAN SYSTEM", Refer to [LAN-9. "Condition of Error Detection"](#).

CAN COMM2 [U1010]>> Replace Intelligent Key unit. Refer to [BL-129. "Removal and Installation of Intelligent Key Unit"](#).

## Power Supply and Ground Circuit Inspection

INFOID:000000004407738

### 1.CHECK POWER SUPPLY CIRCUIT

1. Turn ignition switch OFF.
2. Disconnect Intelligent Key unit connector.
3. Check voltage between Intelligent Key unit harness connector M42 terminals 6, 11 and ground.

Connector	Terminals		Ignition switch position	
	(+)	(-)	OFF	ON
M42	6	Ground	0V	Battery voltage
	11		Battery voltage	Battery voltage

#### OK or NG

OK >> GO TO 2.

NG >> Repair or replace Intelligent Key power supply circuit.

### 2.CHECK GROUND CIRCUIT

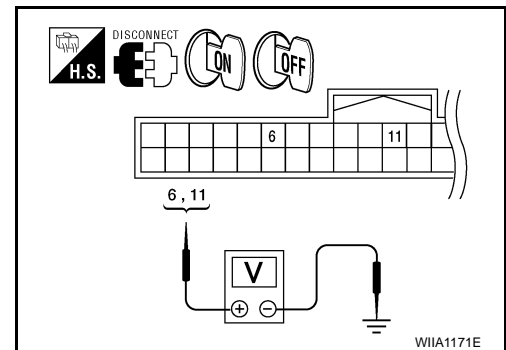

# INTELLIGENT KEY SYSTEM

## < SERVICE INFORMATION >

Check continuity between Intelligent Key unit harness connector M42 terminal 12 and ground.

**12 - Ground : Continuity should exist.**

### OK or NG

- OK >> Power supply and ground circuits are OK.
- NG >> Repair or replace the Intelligent Key unit ground circuit.

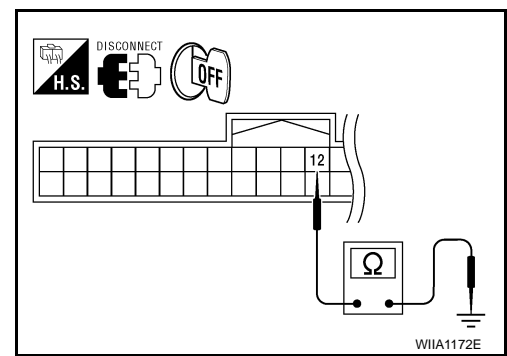

WIIA1172E

INFOID:000000004407739

## Key Switch (Intelligent Key Unit Input) Check

### 1. CHECK KEY SWITCH

#### With CONSULT-III

Check key switch ("KEY SW") in "DATA MONITOR" mode with CONSULT-III.

Monitor item	Condition
KEY SW	Insert mechanical key into ignition switch: ON
	Remove mechanical key from ignition switch: OFF

#### Without CONSULT-III

1. Turn ignition switch OFF.
2. Disconnect Intelligent Key unit harness connector.
3. Check voltage between Intelligent Key unit harness connector M42 terminal 7 and ground.

Connector	Terminals		Condition	Voltage (V) (Approx.)
	(+)	(-)		
M42	7	Ground	Insert mechanical key into ignition switch	Battery voltage
			Remove mechanical key from ignition switch	0

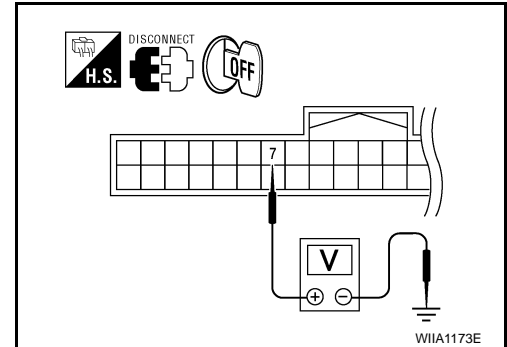

WIIA1173E

### OK or NG

- OK >> Key switch is OK.
- NG >> GO TO 2.

### 2. CHECK KEY SWITCH POWER SUPPLY CIRCUIT

1. Remove mechanical key from ignition switch.
2. Disconnect key switch and ignition knob switch connector.
3. Check voltage between key switch and ignition knob switch harness connector M49 terminal 2 and ground.

**2 - Ground : Battery voltage**

### OK or NG

- OK >> GO TO 3.
- NG >> Repair or replace key switch and ignition knob switch power supply circuit.

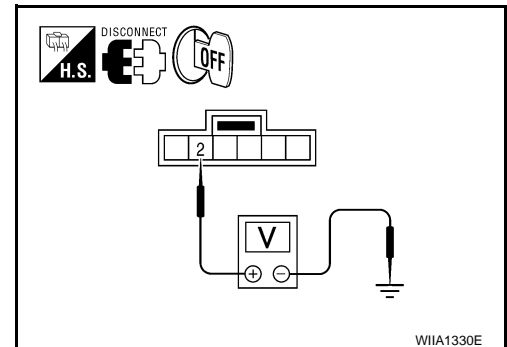

WIIA1330E

### 3. CHECK KEY SWITCH OPERATION

# INTELLIGENT KEY SYSTEM

## < SERVICE INFORMATION >

Check continuity between key switch and ignition knob switch terminals 1 and 2.

Component	Terminals		Condition	Continuity
Key switch	1	2	Insert mechanical key into ignition switch.	Yes
			Remove mechanical key from ignition switch.	No

**OK or NG**

OK >> GO TO 4.

NG >> Replace key cylinder assembly (built-in key switch).

### 4. CHECK KEY SWITCH CIRCUIT

1. Check continuity between Intelligent Key unit harness connector M42 (A) terminal 7 and key switch and ignition knob switch harness connector M49 (B) terminal 1.

**7 - 1 : Continuity should exist.**

2. Check continuity between Intelligent Key unit harness connector M42 (A) terminal 7 and ground.

**7 - Ground : Continuity should not exist.**

**OK or NG**

OK >> Check the condition of harness and harness connector.

NG >> Repair or replace harness between Intelligent Key unit and key switch and ignition knob switch.

### Key Switch (BCM Input) Check

#### 1. CHECK KEY SWITCH POWER SUPPLY CIRCUIT

- Remove mechanical key from ignition switch.
- Disconnect key switch and ignition knob switch connector.
- Check voltage between key switch and ignition knob switch harness connector M49 terminal 2 and ground.

**2 - Ground : Battery voltage.**

**OK or NG**

OK >> GO TO 2.

NG >> Check harness between key switch and ignition knob switch and fuse.

#### 2. CHECK KEY SWITCH

Check continuity between key switch and ignition knob switch terminals 1 and 2.

Component	Terminals		Condition	Continuity
Ignition switch	1	2	Insert mechanical key into ignition switch.	Yes
			Remove mechanical key from ignition switch.	No

**OK or NG**

OK >> GO TO 3.

NG >> Replace key cylinder assembly (built-in key switch).

#### 3. CHECK KEY SWITCH SIGNAL CIRCUIT

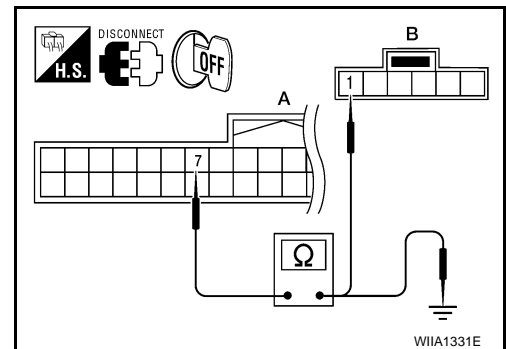
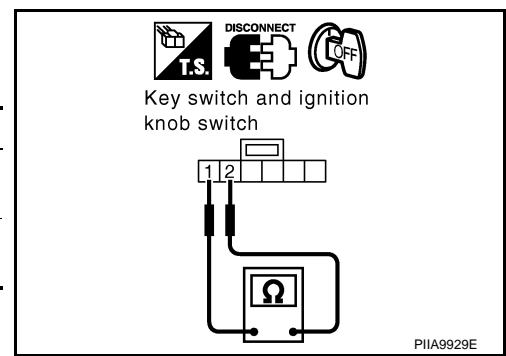

INFOID:000000004407740

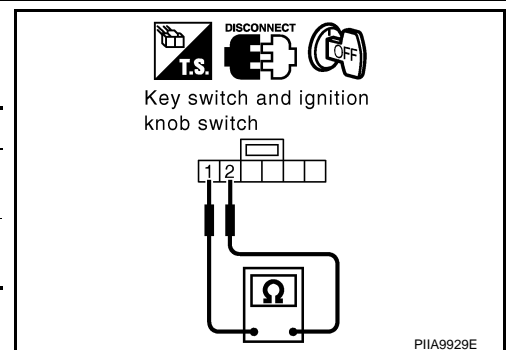
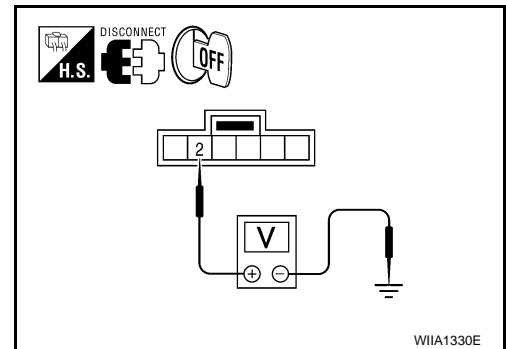



# INTELLIGENT KEY SYSTEM

## < SERVICE INFORMATION >

1. Disconnect BCM connector.
2. Check continuity between BCM harness connector M18 (A) terminal 37 and key switch and ignition knob switch harness connector M49 (B) terminal 1.

**37 – 1 : Continuity should exist.**

3. Check continuity between BCM harness connector M18 (A) terminal 37 and ground.

**37 – Ground : Continuity should not exist.**

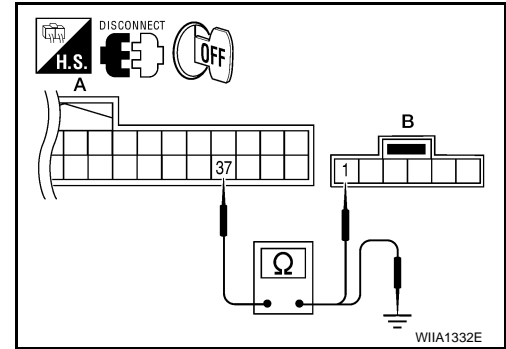

### OK or NG

- OK >> Key switch (BCM input) circuit is OK.
- NG >> Repair or replace harness between key switch and ignition knob switch and BCM.

## Ignition Knob Switch Check

INFOID:000000004407741

### 1. CHECK IGNITION KNOB SWITCH

#### With CONSULT-III

Display "PUSH SW" on DATA MONITOR screen, and check if ON/OFF display is linked to ignition switch operation.

Monitor item	Condition
PUSH SW	Ignition switch is pushed: ON
	Ignition switch is released: OFF

#### Without CONSULT-III

1. Turn ignition switch OFF.
2. Disconnect Intelligent Key unit connector.
3. Check voltage between Intelligent Key unit harness connector M42 terminal 27 and ground.

Connector	Terminals		Condition	Voltage (V) (Approx.)
	(+)	(-)		
M42	27	Ground	Ignition switch is pushed	Battery voltage
			Ignition switch is released	0

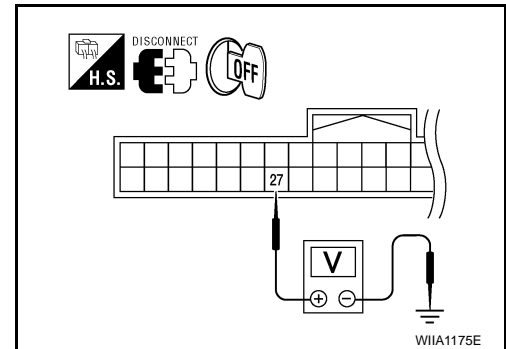

### OK or NG

- OK >> Ignition knob switch is OK.
- NG >> GO TO 2.

### 2. CHECK IGNITION KNOB SWITCH POWER SUPPLY CIRCUIT

1. Turn ignition switch OFF.
2. Disconnect key switch and ignition knob switch connector.
3. Check voltage between key switch and ignition knob switch harness connector M49 terminal 4 and ground.

# INTELLIGENT KEY SYSTEM

## < SERVICE INFORMATION >

### 4 - Ground : Battery voltage

#### OK or NG

- OK >> GO TO 3.
- NG >> Repair or replace key switch and ignition knob switch power supply circuit.

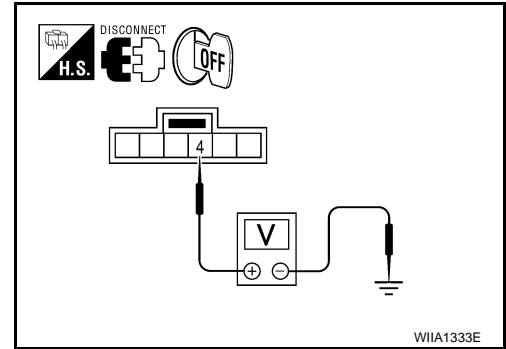

## 3. CHECK IGNITION KNOB SWITCH OPERATION

Check continuity between key switch and ignition knob switch terminals 3 and 4.

Component	Terminals		Condition	Continuity
Ignition knob switch	3	4	Ignition switch is pushed	Yes
			Ignition switch is released	No

#### OK or NG

- OK >> GO TO 4.
- NG >> Replace key switch and ignition knob switch.

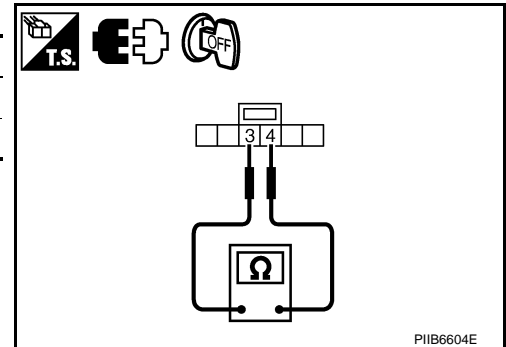

## 4. CHECK IGNITION KNOB SWITCH CIRCUIT

1. Check continuity between Intelligent Key unit harness connector M42 (A) terminal 27 and key switch and ignition knob switch harness connector M49 (B) terminal 3.

### 27 - 3 : Continuity should exist.

2. Check continuity between Intelligent Key unit harness connector M42 terminal 27 and ground.

### 27 - Ground : Continuity should not exist.

#### OK or NG

- OK >> Check the condition of harness and harness connector.
- NG >> Repair or replace harness between Intelligent Key unit and key switch and ignition knob switch.

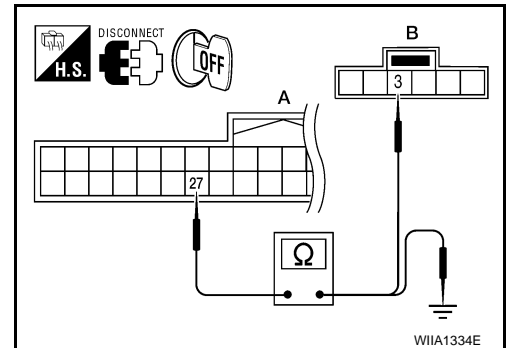

## Door Switch Check

INFOID:000000004407742

## 1. CHECK DOOR SWITCHES INPUT SIGNAL

With CONSULT-III

Check door switches ("DOOR SW-DR", "DOOR SW-AS", "DOOR SW-RL", "DOOR SW-RR") in DATA MONITOR mode with CONSULT-III. Refer to [BL-36. "CONSULT-III Function \(BCM\)"](#).

- When any doors are open:

DOOR SW-DR : ON  
 DOOR SW-AS : ON  
 DOOR SW-RL : ON  
 DOOR SW-RR : ON

- When any doors are closed:

DOOR SW-DR : OFF  
 DOOR SW-AS : OFF

# INTELLIGENT KEY SYSTEM

## < SERVICE INFORMATION >

**DOOR SW-RL : OFF**  
**DOOR SW-RR : OFF**

Without CONSULT-III

Check voltage between BCM connector M18 or M19 terminals 12, 13, 47, 48 and ground.

Connector	Item	Terminals		Condition	Voltage (V) (Approx.)
		(+)	(-)		
M19	Front door switch LH	47	Ground	Open ↓ Closed	0 ↓ Battery voltage
	Rear door switch LH	48			
M18	Front door switch RH	12			
	Rear door switch RH	13			

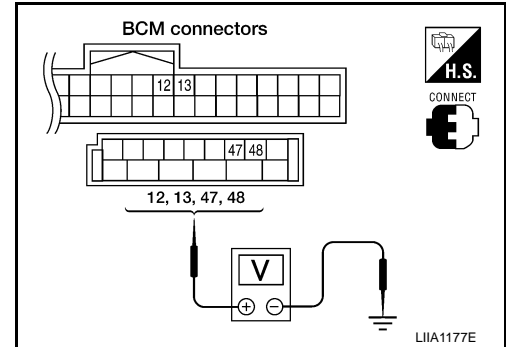

### OK or NG

OK >> Door switch circuit is OK.  
 NG >> GO TO 2.

## 2.CHECK DOOR SWITCH CIRCUIT

- Turn ignition switch OFF.
- Disconnect door switch and BCM.
- Check continuity between door switch connector B21 (Front LH), B28 (Front RH), B26 (Rear LH), B41 (Rear RH) terminal 2 and BCM connector M18, M19 terminals 12, 13, 47 and 48.

**2 - 47 : Continuity should exist.**  
**2 - 12 : Continuity should exist.**  
**2 - 48 : Continuity should exist.**  
**2 - 13 : Continuity should exist.**

- Check continuity between door switch connector B21 (Front LH), B28 (Front RH), B26 (Rear LH), B41 (Rear RH) terminal 2 and ground.

**2 - Ground : Continuity should not exist.**

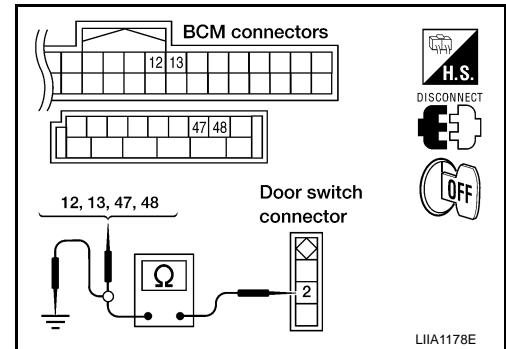

### OK or NG

OK >> GO TO 3.  
 NG >> Repair or replace harness.

## 3.CHECK DOOR SWITCHES

Check continuity between door switch terminals.

Door switch (front or rear)	Terminals	Condition	Continuity
		2 - Ground	Pressed
		Released	Yes

### OK or NG

OK >> GO TO 4.  
 NG >> Replace door switch.

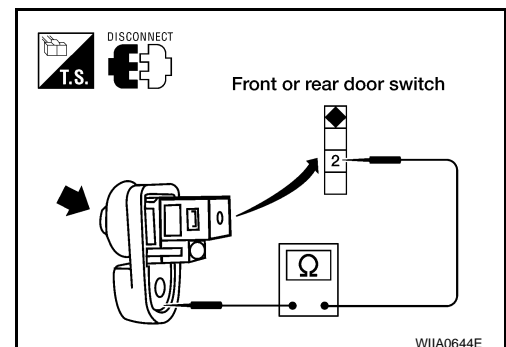

## 4.CHECK BCM OUTPUT VOLTAGE

- Reconnect BCM connectors.

# INTELLIGENT KEY SYSTEM

## < SERVICE INFORMATION >

- Check voltage between BCM connector M18, M19 terminals 12, 13, 47, 48 and ground.

**12 - Ground : Battery voltage**  
**13 - Ground : Battery voltage**  
**47 - Ground : Battery voltage**  
**48 - Ground : Battery voltage**

### OK or NG

- OK >> Door switch circuit is OK.  
 NG >> Replace BCM. Refer to [BCS-17. "Removal and Installation of BCM"](#).

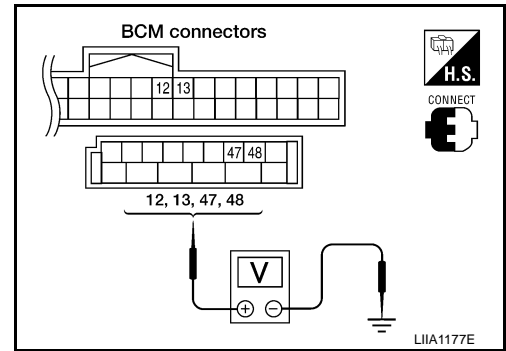

## Trunk Room Lamp Switch Check

INFOID:000000004407743

### 1. CHECK TRUNK ROOM LAMP SWITCH INPUT SIGNAL

#### With CONSULT-III

Check ("TRUNK SW") in "DATA MONITOR" mode with CONSULT-III.

Monitor item	Trunk condition
TRUNK SW	OPEN : ON
	CLOSED : OFF

#### Without CONSULT-III

- Turn ignition switch OFF.
- Check voltage between BCM harness connector M19 terminal 42 and ground.

Connector	Terminals		Trunk condition	Voltage (V) (Approx.)
	(+)	(-)		
M19	42	Ground	CLOSED	Battery voltage
			OPEN	0

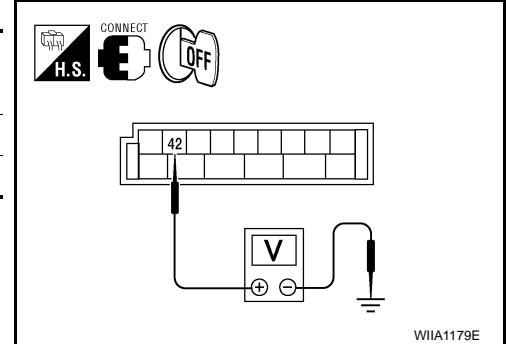

### OK or NG

- OK >> Trunk room lamp switch circuit is OK.  
 NG >> GO TO 2.

### 2. CHECK TRUNK ROOM LAMP SWITCH

- Turn ignition switch OFF.
- Disconnect trunk room lamp switch connector.
- Check continuity between trunk room lamp switch terminals 1 and 2.

Terminals		Trunk condition	Continuity
1	2	CLOSED	No
		OPEN	Yes

### OK or NG

- OK >> GO TO 3.  
 NG >> Replace trunk room lamp switch.

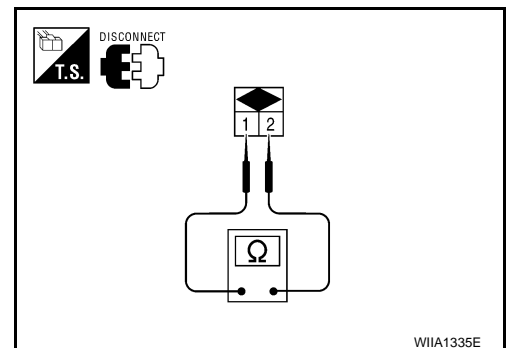

### 3. CHECK TRUNK ROOM LAMP SWITCH CIRCUIT

- Disconnect BCM connector M19.

# INTELLIGENT KEY SYSTEM

## < SERVICE INFORMATION >

- Check continuity between BCM harness connector M19 (A) terminal 42 and trunk room lamp switch harness connector B57 (B) terminal 1.

**42 – 1 : Continuity should exist.**

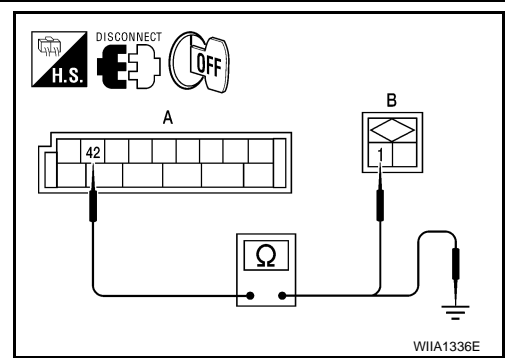

- Check continuity between BCM harness connector M19 (A) terminal 42 and ground.

**42 – Ground : Continuity should not exist.**

### OK or NG

OK >> GO TO 4.

NG >> Repair or replace harness between BCM and trunk room lamp switch.

## 4.CHECK TRUNK ROOM LAMP SWITCH GROUND CIRCUIT

Check continuity between trunk room lamp switch harness connector B57 terminal 2 and ground.

**2 – Ground : Continuity should exist.**

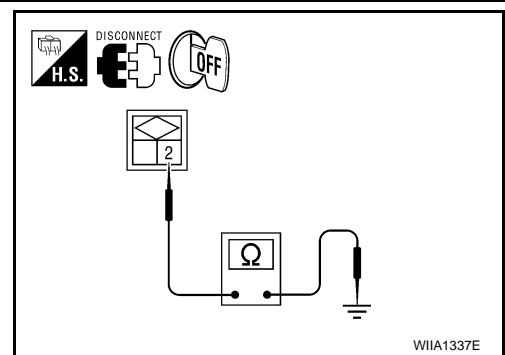

### OK or NG

OK >> Check connection of harness and connector.

NG >> Repair or replace trunk room lamp switch ground circuit.

## Front Door Request Switch Check

INFOID:000000004407744

## 1.CHECK FRONT DOOR REQUEST SWITCH

### With CONSULT-III

Check front door request switch ("DR REQ SW" or "AS REQ SW") in "DATA MONITOR" mode.

Monitor item	Condition
DR REQ SW	Front door request switch is pressed: ON
AS REQ SW	Front door request switch is released: OFF

### Without CONSULT-III

- Turn ignition switch OFF.

# INTELLIGENT KEY SYSTEM

## < SERVICE INFORMATION >

- Check voltage between Intelligent Key unit harness connector M42 terminals 5, 25 and ground.

Connector	Item	Terminals		Condition	Voltage (V) (Approx.)
		(+)	(-)		
M42	Front door request switch LH	5	Ground	Door request switch is pressed	0 ↓ Battery voltage
	Front door request switch RH	25		Door request switch is released	

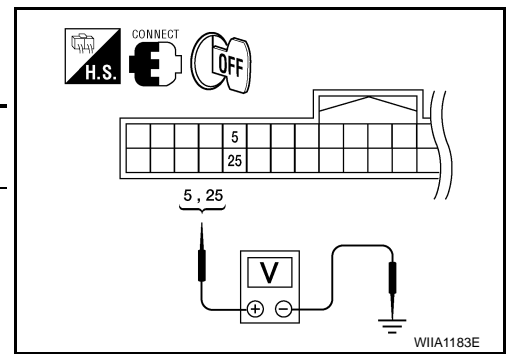

### OK or NG

- OK >> Front door request switch is OK.
- NG >> GO TO 2.

## 2. CHECK FRONT DOOR REQUEST SWITCH OPERATION

- Turn ignition switch OFF.
- Disconnect front door request switch connector.
- Check continuity between front door request switch terminals 3 and 4.

Component	Terminals		Condition	Continuity
Front door request switch (LH or RH)	3	4	Front door request switch is pressed	Yes
			Front door request switch is released	No

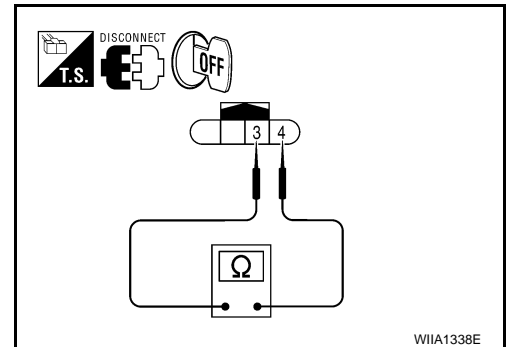

### OK or NG

- OK >> GO TO 3.
- NG >> Replace front door request switch.

## 3. CHECK FRONT DOOR REQUEST SWITCH GROUND CIRCUIT

Check continuity between front door request switch harness connector D4 (LH), D103 (RH) terminal 4 and ground.

**4 - Ground : Continuity should exist.**

### OK or NG

- OK >> GO TO 4.
- NG >> Repair or replace door request switch ground circuit.

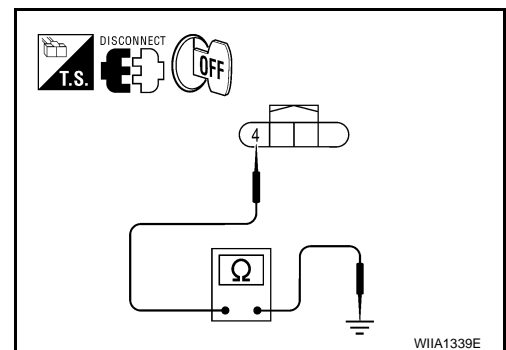

## 4. CHECK FRONT DOOR REQUEST SWITCH CIRCUIT

- Disconnect Intelligent Key unit connector.
- Check continuity between Intelligent Key unit harness connector M42 (A) terminals 5 (LH), 25 (RH) and front door request switch harness connector D4 (B) (LH), D103 (RH) terminal 3.

# INTELLIGENT KEY SYSTEM

## < SERVICE INFORMATION >

- Driver side 5 - 3 : Continuity should exist.**  
**Passenger side 25 - 3 : Continuity should exist.**

3. Check continuity between front door request switch harness connector D4 (B) (LH), D103 (RH), terminal 3 and ground.

**3 - Ground : Continuity should not exist.**

### OK or NG

- OK >> GO TO 5.  
 NG >> Repair or replace harness between Intelligent Key unit and front door request switch.

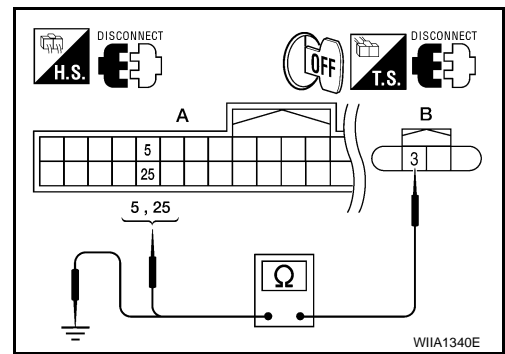

## 5. CHECK FRONT DOOR REQUEST SWITCH SIGNAL

1. Connect Intelligent Key unit connector.  
 2. Check voltage between front door request switch harness connector D4 (LH), D103 (RH) terminal 3 and ground.

- LH: 3 - Ground : Battery voltage**  
**RH: 3 - Ground : Battery voltage**

### OK or NG

- OK >> Check condition of harness and connector.  
 NG >> Replace Intelligent Key Unit. Refer to [BL-129, "Removal and Installation of Intelligent Key Unit"](#).

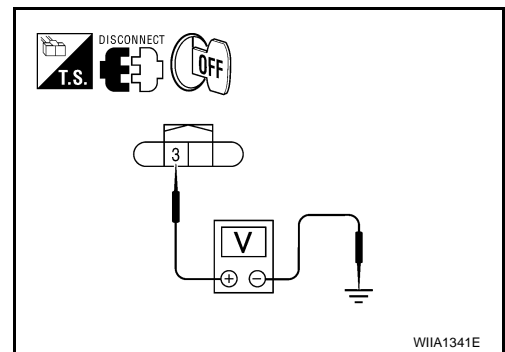

## Trunk Opener Request Switch Check

### 1. CHECK TRUNK OPENER REQUEST SWITCH

#### With CONSULT-III

Check trunk opener request switch ("BD/TR REQ SW") in "DATA MONITOR" mode.

Monitor item	Condition
BD/TR REQ SW	Trunk opener request switch is pressed: ON
	Trunk opener request switch is released: OFF

#### Without CONSULT-III

1. Turn ignition switch OFF.  
 2. Check voltage between Intelligent Key unit connector M42 terminal 29 and ground.

Connector	Terminals		Condition	Voltage (V) (Approx.)
	(+)	(-)		
M42	29	Ground	Trunk opener request switch is pressed	0
			Trunk opener request switch is released	5

### OK or NG

- OK >> Trunk opener request switch is OK.  
 NG >> GO TO 2.

## 2. CHECK TRUNK OPENER REQUEST SWITCH OPERATION

1. Turn ignition switch OFF.

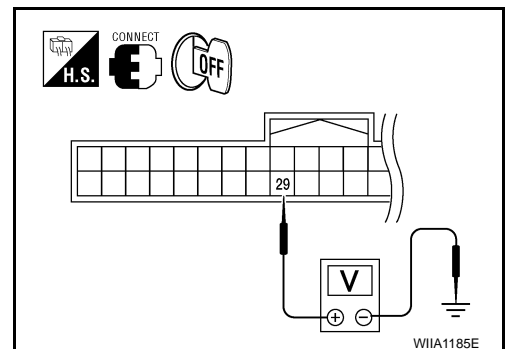

# INTELLIGENT KEY SYSTEM

## < SERVICE INFORMATION >

- Disconnect trunk opener request switch connector.
- Check continuity between trunk opener request switch terminals 1 and 2.

Component	Terminals		Condition	Continuity
Trunk opener request switch	1	2	Trunk opener request switch is pressed	Yes
			Trunk opener request switch is released	No

### OK or NG

- OK >> GO TO 3.  
 NG >> Replace trunk opener request switch.

## 3.CHECK TRUNK OPENER REQUEST SWITCH GROUND CIRCUIT

Check continuity between trunk opener request switch harness connector T5 terminal 2 and ground.

**2 - Ground : Continuity should exist.**

### OK or NG

- OK >> GO TO 4.  
 NG >> Repair or replace trunk opener request switch ground circuit.

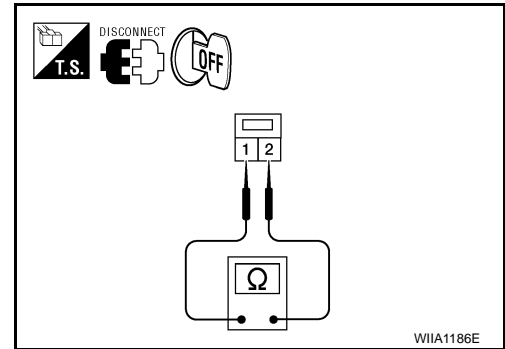

WIA1186E

## 4.CHECK TRUNK OPENER REQUEST SWITCH CIRCUIT

- Disconnect Intelligent Key unit connector.
- Check continuity between Intelligent Key unit harness connector M42 (A) terminal 29 and trunk opener request switch harness connector T5 (B) terminal 1.

**29 - 1 : Continuity should exist.**

- Check continuity between Intelligent Key unit harness connector M42 (A) terminal 29 and ground.

**29 - Ground : Continuity should not exist.**

### OK or NG

- OK >> GO TO 5.  
 NG >> Repair or replace harness between Intelligent Key unit and trunk opener request switch.

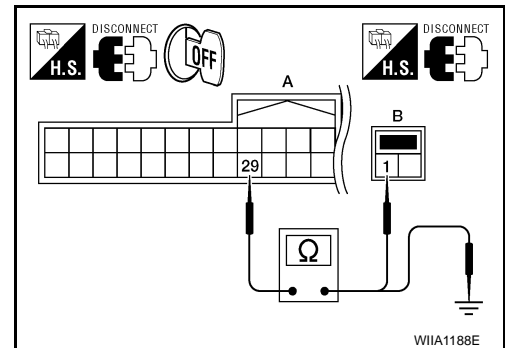

WIA1188E

## 5.CHECK TRUNK OPENER REQUEST SWITCH SIGNAL

- Connect Intelligent Key Unit connector.
- Check voltage between trunk opener request switch harness connector T5 terminal 1 and ground.

**1 - Ground : Battery voltage**

### OK or NG

- OK >> Check condition of harness and connector.  
 NG >> Replace Intelligent Key unit. Refer to [BL-129. "Removal and Installation of Intelligent Key Unit"](#).

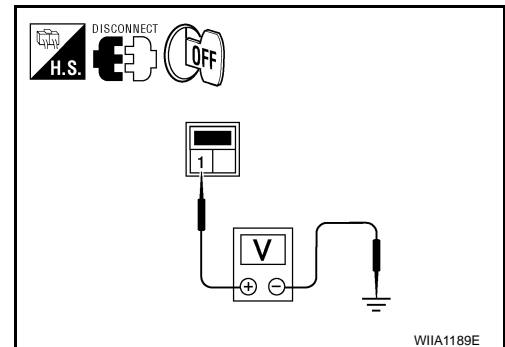

WIA1189E



# INTELLIGENT KEY SYSTEM

< SERVICE INFORMATION >

## Front Door Lock Assembly LH (Door Unlock Sensor) Check

INFOID:000000004407746

### 1. CHECK UNLOCK SENSOR POWER SUPPLY

Check voltage between Intelligent Key unit connector terminal 28 and ground.

Connector	Terminals		Condition	Voltage (V) (Approx.)
	(+)	(-)		
M42	28	Ground	Driver side door lock is locked	5
			Driver side door lock is un-locked	0

**OK or NG**

- OK >> front door lock assembly LH (door unlock sensor) is OK.
- NG >> GO TO 2.

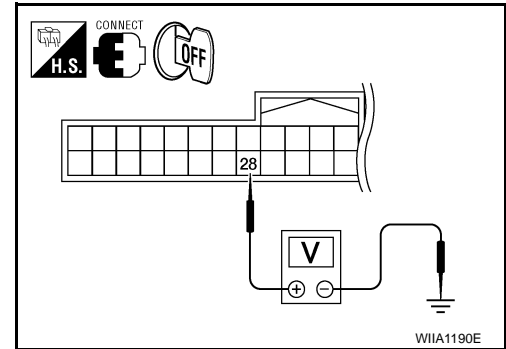

### 2. CHECK UNLOCK SENSOR CIRCUIT

1. Turn ignition switch OFF.
2. Disconnect Intelligent Key unit and front door lock assembly LH (door unlock sensor) connector.
3. Check continuity between Intelligent Key unit harness connector M42 (A) terminal 28 and front door lock assembly LH (door unlock sensor) harness connector D9 (B) terminal 3.

**28 – 3 : Continuity should exist.**

4. Check continuity between Intelligent Key unit harness connector M42 (A) terminal 28 and ground.

**28 – Ground : Continuity should not exist.**

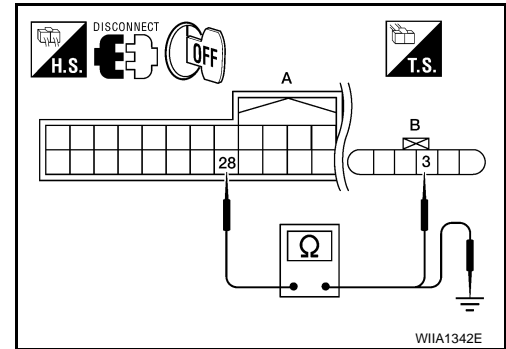

**OK or NG**

- OK >> GO TO 3.
- NG >> Repair or replace harness between Intelligent Key unit and front door lock assembly LH (door unlock sensor).

### 3. CHECK UNLOCK SENSOR GROUND CIRCUIT

Check continuity between front door lock assembly LH (door unlock sensor) harness connector D9 terminal 4 and ground.

**4 – Ground : Continuity should exist.**

**OK or NG**

- OK >> GO TO 4.
- NG >> Repair or replace harness.

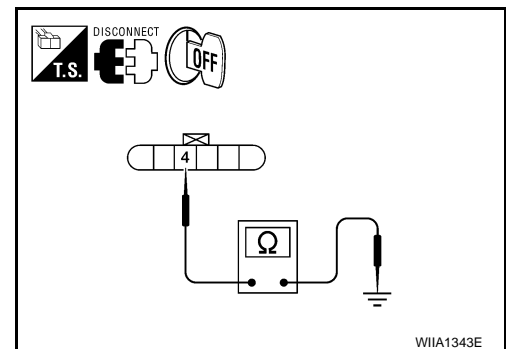

### 4. CHECK INTELLIGENT KEY UNIT OUTPUT SIGNAL

1. Connect Intelligent Key unit harness connector.
2. Check voltage between Intelligent Key unit harness connector M42 terminal 28 and ground.

# INTELLIGENT KEY SYSTEM

## < SERVICE INFORMATION >

**28 – Ground : Approx. 5V**

### OK or NG

- OK >> Replace front door lock assembly LH (door unlock sensor).
- NG >> Replace Intelligent Key unit. Refer to [BL-129. "Removal and Installation of Intelligent Key Unit"](#).

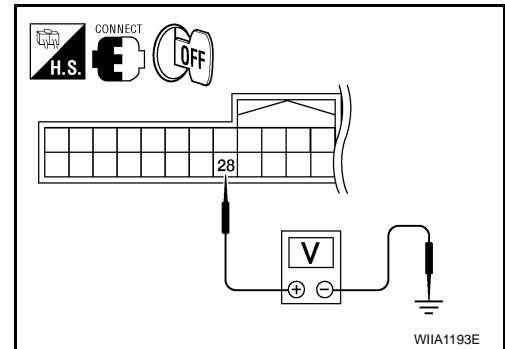

## Intelligent Key Warning Chime (Combination Meter) Check

INFOID:000000004407747

### 1. CHECK INTELLIGENT KEY WARNING CHIME (COMBINATION METER) OPERATION

Using CONSULT-III, enter "INTELLIGENT KEY" menu and select "ACTIVE TEST". Activate "INSIDE BUZZER" and listen for a chime response.

### OK or NG

- OK >> Warning chime is OK.
- NG >> Refer to [DI-48](#).

## Check Intelligent Key Warning Buzzer (Front of Vehicle)

INFOID:000000004407748

### 1. CHECK INTELLIGENT KEY WARNING BUZZER (FRONT OF VEHICLE) POWER SUPPLY CIRCUIT

1. Turn ignition switch OFF.
2. Disconnect Intelligent Key warning buzzer (front of vehicle) connector.
3. Check voltage between Intelligent Key warning buzzer (front of vehicle) harness connector E26 terminal 1 and ground.

**1 - Ground : Battery voltage**

### OK or NG

- OK >> GO TO 2.
- NG >> Repair or replace Intelligent Key warning buzzer (front of vehicle) power supply circuit.

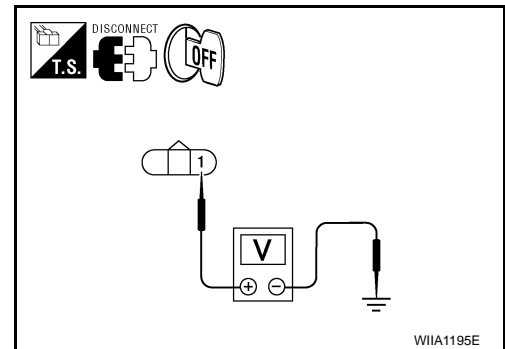

### 2. CHECK INTELLIGENT KEY WARNING BUZZER (FRONT OF VEHICLE) CIRCUIT

1. Disconnect Intelligent Key unit connector.
2. Check continuity between Intelligent Key unit harness connector M42 (A) terminal 4 and Intelligent Key warning buzzer (front of vehicle) harness connector E26 (B) terminal 3.

**4 - 3 : Continuity should exist.**

3. Check continuity between Intelligent Key warning buzzer (front of vehicle) harness connector E26 (B) terminal 3 and ground.

**3 - Ground : Continuity should not exist.**

### OK or NG

- OK >> GO TO 3.
- NG >> Repair or replace harness between Intelligent Key warning buzzer (front of vehicle) and Intelligent Key unit.

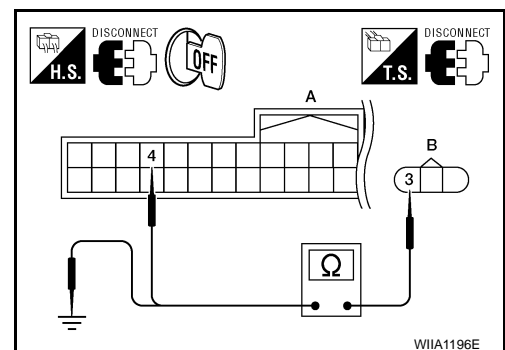

# INTELLIGENT KEY SYSTEM

< SERVICE INFORMATION >

## 3. CHECK INTELLIGENT KEY WARNING BUZZER (FRONT OF VEHICLE) OPERATION

Connect battery power supply to Intelligent Key warning buzzer (front of vehicle) harness connector E26 terminals 1 and 3, and check the operation.

**1 (BAT+) - 3 (BAT-) : The buzzer sounds**

**OK or NG**

- OK >> Intelligent Key warning buzzer (front of vehicle) is OK.
- NG >> Replace Intelligent Key warning buzzer (front of vehicle).

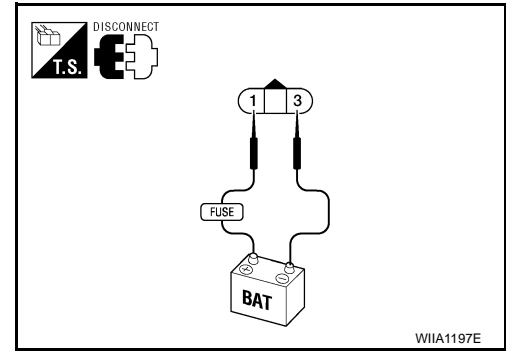

INFOID:000000004407749

## Outside Key Antenna Check

### 1. CHECK OUTSIDE KEY ANTENNA INPUT SIGNAL

- Turn ignition switch OFF.
- Check signal between Intelligent Key unit connector M42 terminals 17, 19, 37 and ground with an oscilloscope.

Connector	Item	Terminals		Condition	Signal (Reference value)
		(+)	(-)		
M42	Rear bumper antenna	17	Ground	Request switch is pushed	
	Front outside antenna LH	19			
	Front outside antenna RH	37			

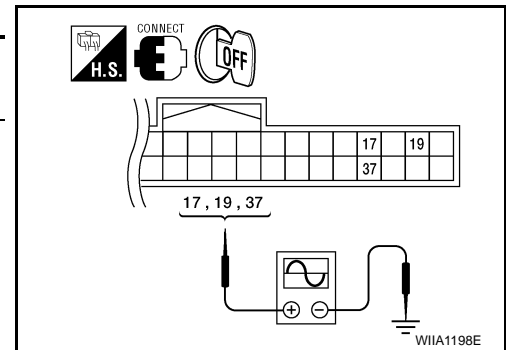

**OK or NG**

- OK >> Outside key antenna is OK.
- NG >> GO TO 2.

### 2. CHECK OUTSIDE KEY ANTENNA CIRCUIT

- Disconnect Intelligent Key unit connector and outside key antenna connector.
- Check continuity between each outside key antenna harness connector D4 (B) (LH) or D103 (B) (RH), rear bumper antenna connector B49 (C) terminals 1, 2 and Intelligent Key unit harness connector M42 (A) terminals 17, 18, 19, 20, 37, and 38.

# INTELLIGENT KEY SYSTEM

## < SERVICE INFORMATION >

Item	Connector	Terminal	Connector	Terminal	Continuity
Rear bumper antenna	C: B49	1	A: M42	17	Yes
		2		18	
Front outside antenna LH	B: D4	1		19	
		2		20	
Front outside antenna RH	B: D103	1		37	
		2		38	

3. Check continuity between each outside key antenna harness connector terminals 1, 2 and ground.

Item	Connector	Terminal	Continuity
Rear bumper antenna	C: B49	1	No
		2	
Front outside antenna LH	B: D4	1	
		2	
Front outside antenna RH	B: D103	1	
		2	

### OK or NG

OK >> GO TO 3.

NG >> Replace harness between outside key antenna and Intelligent Key unit.

## 3.CHECK OUTSIDE KEY ANTENNA POWER SUPPLY

1. Replace outside key antenna. (New antenna or other antenna)
2. Connect Intelligent Key unit connector and outside key antenna connector.
3. Check signal between Intelligent Key unit connector terminals 17, 19, 37 and ground with an oscilloscope.

Connector	Item	Terminals		Condition	Signal (Reference value)
		(+)	(-)		
M42	Rear bumper antenna	17	Ground	Request switch is pushed	
	Front outside antenna LH	19			
	Front outside antenna RH	37			

### OK or NG

OK >> Replace outside key antenna.

NG >> Replace Intelligent Key unit. Refer to [BL-129, "Removal and Installation of Intelligent Key Unit"](#).

## Inside Key Antenna Check

INFOID:000000004407750

## 1.CHECK INSIDE KEY ANTENNA POWER SUPPLY SIGNAL

1. Turn ignition switch OFF.
2. Check signal between Intelligent Key unit connector and ground with an oscilloscope.

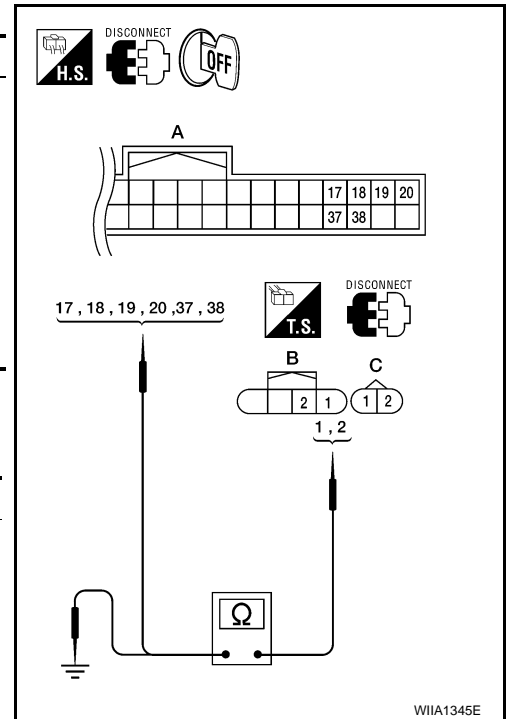

WIA1345E

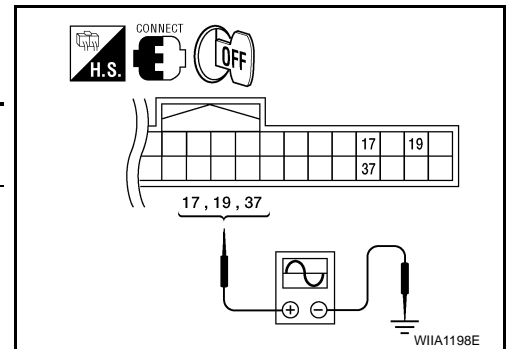

WIA1198E

# INTELLIGENT KEY SYSTEM

## < SERVICE INFORMATION >

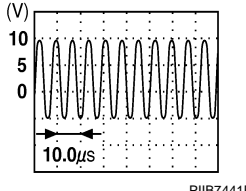
Connector	Item	Terminals		Condition	Signal (V) (Reference value)
		(+)	(-)		
M42	Rear parcel shelf antenna	33	Ground	Any door is open → All doors are closed	
	Front console antenna	15	Ground	Ignition switch is pushed.	
	Instrument panel antenna	13			

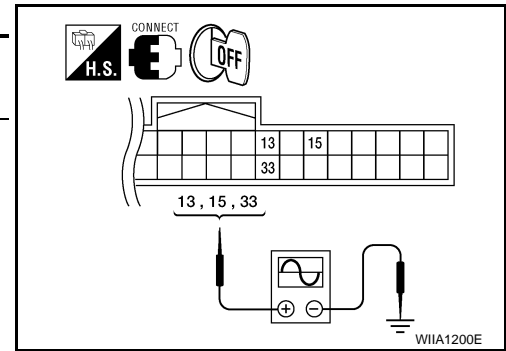

### OK or NG

- OK >> Inside key antenna is OK.
- NG >> GO TO 2.

## 2. CHECK INSIDE KEY ANTENNA

1. Disconnect Intelligent Key unit connector and inside key antenna connectors.
2. Check continuity between inside key antenna harness connector M25 (B) (instrument panel), B18 (B) (front console), B45 (B) (rear parcel shelf) terminals 1, 2 and Intelligent Key unit harness connector M42 (A) terminals 13, 14, 15, 16, 33 and 34.

Item	Connector	Terminal	Connector	Terminal	Continuity
Instrument panel antenna	B: M25	2	A: M42	13	Yes
		1		14	
Front console antenna	B: B18	1		15	
		2		16	
Rear parcel shelf antenna	B: B45	1		33	
		2		34	

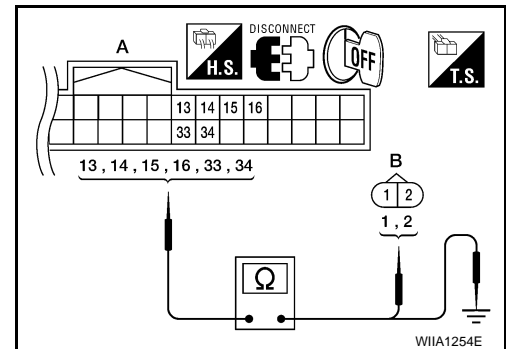

3. Check continuity between Intelligent Key unit harness connector M42 (A) terminals 13, 14, 15, 16, 33, 34 and ground.

Item	Connector	Terminals	Continuity
Intelligent Key unit	A: M42	13	Ground
		14	
		15	
		16	
		33	
		34	

### OK or NG

- OK >> GO TO 3.
- NG >> Repair or replace harness between inside key antenna and Intelligent Key unit.

## 3. CHECK INSIDE KEY ANTENNA POWER SUPPLY SIGNAL

1. Replace inside key antenna. (New antenna or other antenna)
2. Connect Intelligent Key unit connector.

# INTELLIGENT KEY SYSTEM

## < SERVICE INFORMATION >

- Check signal between Intelligent Key unit connector and ground with oscilloscope.

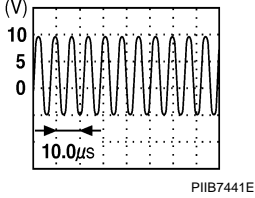
Connector	Item	Terminals		Condition	Signal (V) (Reference value)
		(+)	(-)		
M42	Rear parcel shelf antenna	33	Ground	Any door is open → All doors are closed	
	Front console antenna	15	Ground	Ignition switch is pushed.	
	Instrument panel antenna	13			

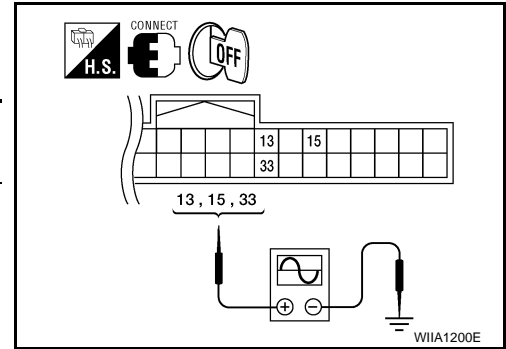

### OK or NG

OK >> Replace inside key antenna.

NG >> Replace Intelligent Key unit. Refer to [BL-129, "Removal and Installation of Intelligent Key Unit"](#).

## Steering Lock Solenoid Check

INFOID:000000004407751

### 1. CHECK STEERING LOCK SOLENOID POWER SUPPLY

- Turn ignition switch OFF.
- Disconnect steering lock solenoid connector.
- Check voltage between steering lock solenoid harness connector M27 terminal 1 and ground.

**1 - Ground : Battery voltage**

### OK or NG

OK >> GO TO 2.

NG >> Repair or replace steering lock solenoid power supply circuit.

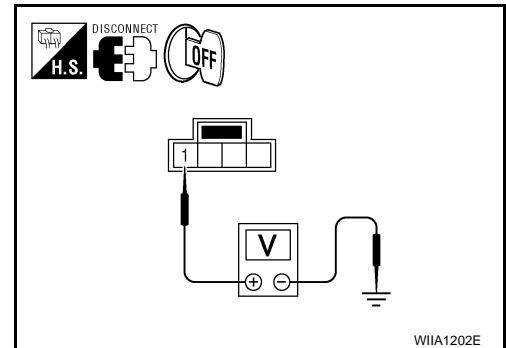

### 2. CHECK STEERING LOCK SOLENOID GROUND CIRCUIT

Check continuity between steering lock solenoid harness connector M27 terminal 4 and ground.

**4 - Ground : Continuity should exist.**

### OK or NG

OK >> GO TO 3.

NG >> Repair or replace the steering lock solenoid ground circuit.

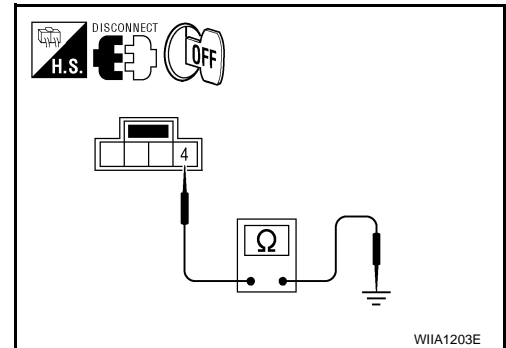

### 3. CHECK INTELLIGENT KEY UNIT OUTPUT SIGNAL

- Connect steering lock solenoid connector.
- Check voltage between Intelligent Key unit harness connector M42 terminal 1 and ground.

# INTELLIGENT KEY SYSTEM

## < SERVICE INFORMATION >

**1 - Ground : Approx. 5V**

### OK or NG

- OK >> GO TO 4.
- NG >> Replace Intelligent Key unit. Refer to [BL-129. "Removal and Installation of Intelligent Key Unit"](#).

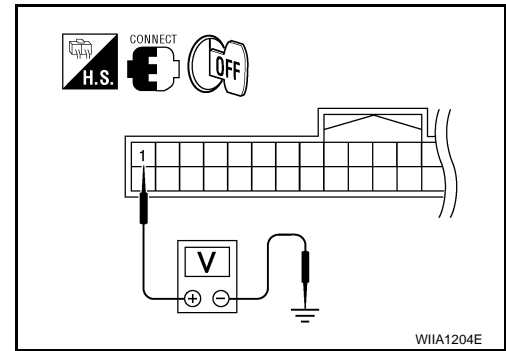

## 4. CHECK STEERING LOCK COMMUNICATION SIGNAL

Check signal between Intelligent Key unit connector M42 terminal 32 and ground with oscilloscope.

Connector	Terminals		Condition	Signal (V) (Reference value)
	(+)	(-)		
M42	32	Ground	Ignition switch is pushed	<p>SIIA1911J</p>

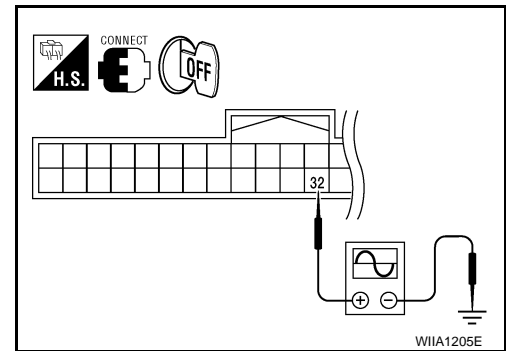

### OK or NG

- OK >> GO TO 5.
- NG >> Replace Intelligent Key unit. Refer to [BL-129. "Removal and Installation of Intelligent Key Unit"](#).

## 5. CHECK STEERING LOCK SOLENOID COMMUNICATION CIRCUIT

1. Disconnect Intelligent Key unit and steering lock solenoid connectors.
2. Check continuity between Intelligent Key unit harness connector M42 (B) terminals 1, 32 and steering lock solenoid connector M27 (A) terminals 2, 3.

**1 - 2 : Continuity should exist.**

**32 - 3 : Continuity should exist.**

3. Check continuity between steering lock solenoid harness connector M27 (A) terminals 2, 3 and ground.

**2 - Ground : Continuity should not exist.**

**3 - Ground : Continuity should not exist.**

### OK or NG

- OK >> Replace steering lock solenoid.
  - After replacing steering lock solenoid, perform registration procedure. Refer to [BL-72. "System Description"](#).
- NG >> Repair or replace harness between steering lock solenoid and Intelligent Key unit.

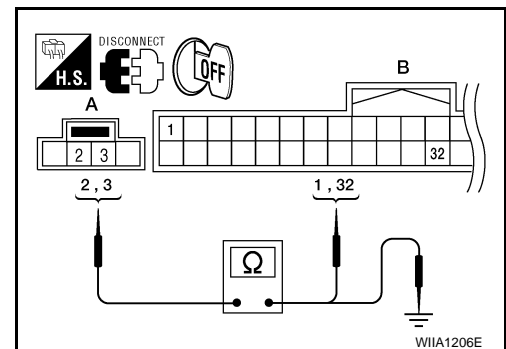

## Stop Lamp Switch Check

INFOID:000000004407752

### 1. CHECK STOP LAMP SWITCH INPUT SIGNAL

#### With CONSULT-III

Check stop lamp switch ("STOP LAMP SW") in "DATA MONITOR" mode with CONSULT-III.

# INTELLIGENT KEY SYSTEM

## < SERVICE INFORMATION >

Monitor item	Condition
STOP LAMP SW	Brake pedal depressed: ON
	Brake pedal released: OFF

### ⊗ Without CONSULT-III

1. Turn ignition switch OFF.
2. Disconnect BCM.
3. Check voltage between BCM connector M18 terminal 9 and ground.

Connector	Terminals		Condition	Voltage (V) (Approx.)
	(+)	(-)		
M18	9	Ground	Brake pedal depressed	Battery voltage
			Brake pedal released	0

### OK or NG

- OK >> Stop lamp switch circuit is OK.  
 NG >> GO TO 2.

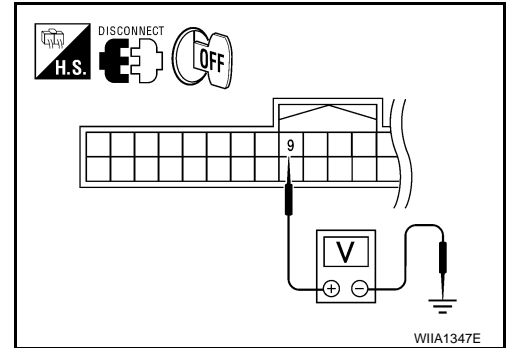

## 2. CHECK STOP LAMP SWITCH POWER SUPPLY CIRCUIT

Check voltage between stop lamp switch harness connector E60 terminal 1 and ground.

**1 - Ground** : **Battery voltage**

### OK or NG

- OK >> GO TO 3.  
 NG >> Repair or replace harness between stop lamp switch power supply circuit and fuse.

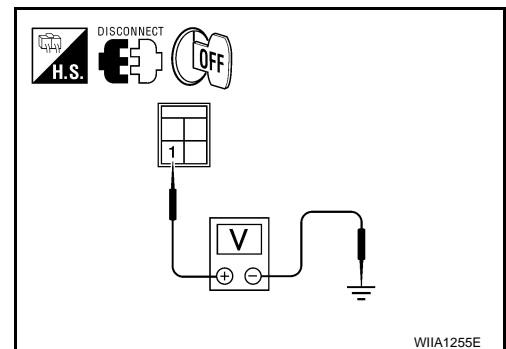

## 3. CHECK STOP LAMP SWITCH OPERATION

Check continuity between stop lamp switch terminals 1 and 2.

Component	Terminals		Condition	Continuity
Stop lamp switch	1	2	Brake pedal depressed	Yes
			Brake pedal not depressed	No

### OK or NG

- OK >> GO TO 4.  
 NG >> Replace stop lamp switch.

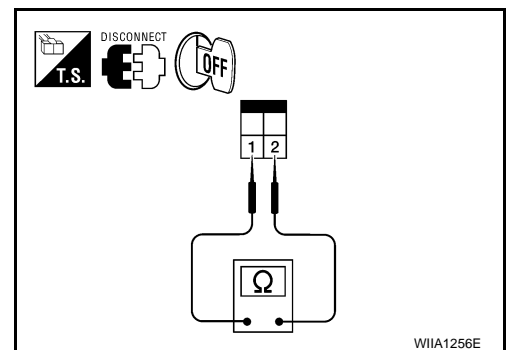

## 4. CHECK STOP LAMP SWITCH CIRCUIT



# INTELLIGENT KEY SYSTEM

## < SERVICE INFORMATION >

1. Check continuity between BCM connector M18 (A) terminal 9 and stop lamp switch connector E60 (B) terminal 2.

**9 - 2 : Continuity should exist.**

2. Check continuity between BCM connector M18 (A) terminal 9 and ground.

**9 - Ground : Continuity should not exist.**

### OK or NG

- OK >> Check condition of harness and connector.
- NG >> Repair or replace harness.

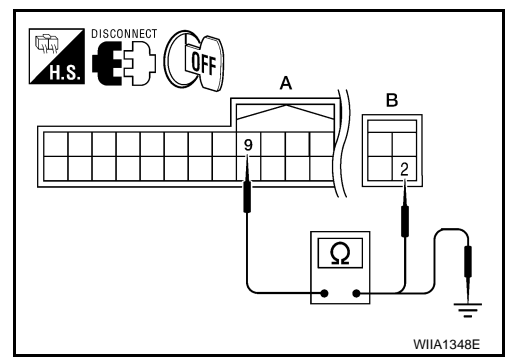

WIIA1348E

INFOID:000000004407753

## CVT Device (Park Position Switch) Check

### 1. CHECK CVT DEVICE (PARK POSITION SWITCH) INPUT SIGNAL

1. Turn ignition switch OFF.
2. Check for continuity between Intelligent Key unit harness connector M42 terminal 10 and ground.

Connector	Terminals		Condition	Continuity
	(+)	(-)		
M42	10	Ground	Selector lever is in "P" position	Yes
			Other than above	No

### OK or NG

- OK >> Replace Intelligent Key unit. Refer to [BL-129. "Removal and Installation of Intelligent Key Unit"](#).
- NG >> GO TO 2.

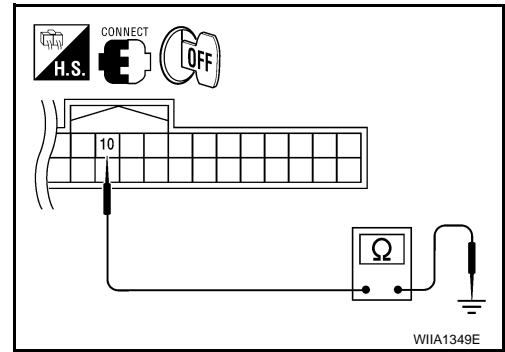

WIIA1349E

### 2. CHECK CVT DEVICE (PARK POSITION SWITCH) GROUND CIRCUIT

1. Disconnect CVT device (park position switch) connector.
2. Check for continuity between CVT device (park position switch) harness connector M38 terminal 2 and ground.

**2 - Ground : Continuity should exist.**

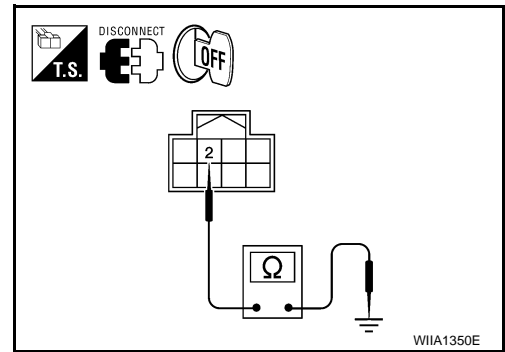

WIIA1350E

### OK or NG

- OK >> GO TO 3.
- NG >> Repair or replace harness.

### 3. CHECK CVT DEVICE (PARK POSITION SWITCH)

Check continuity between CVT device (park position switch) terminals 2 and 5.

# INTELLIGENT KEY SYSTEM

## < SERVICE INFORMATION >

Component	Terminals		Condition	Continuity
CVT device (park position switch)	2	5	Selector lever is in "P" position	Yes
			Other than above	No

### OK or NG

- OK >> Repair or replace harness.  
NG >> Replace CVT device (park position switch).

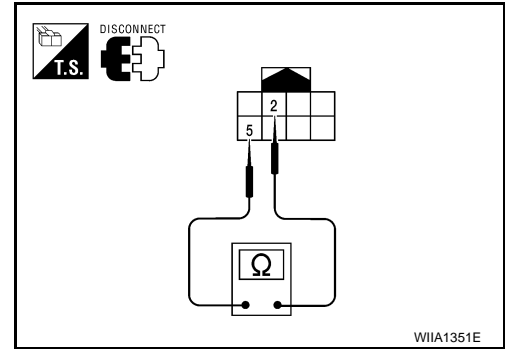

INFOID:000000004407754

## "P-SHIFT" Warning Lamp Check

### 1. CHECK WARNING LAMP OPERATION

#### With CONSULT-III

- Check "INDICATOR" in "ACTIVE TEST" mode with CONSULT-III.
- Select "KNOB ON".

"P-SHIFT" warning lamp should illuminate.

#### Without CONSULT-III

1. Turn ignition switch OFF.
2. While monitoring the combination meter warning lamps, turn ignition switch ON. "P-SHIFT" warning lamp should illuminate for 1 second to perform a bulb check.

### OK or NG

- OK >> Inspection end.  
NG >> Check combination meter. Refer to [DI-5](#).

## "KEY" Warning Lamp (RED) Check

INFOID:000000004407755

### 1. CHECK WARNING LAMP OPERATION

#### With CONSULT-III

- Check "INDICATOR" in "ACTIVE TEST" mode with CONSULT-III.
- Select "RED ON".

"KEY" warning lamp (red) should illuminate.

#### Without CONSULT-III

1. Turn ignition switch OFF.
2. Ensure Intelligent Key is outside and away from the vehicle.
3. While monitoring the combination meter warning lamps, push the ignition knob switch.
4. The "KEY" warning lamp (red) should illuminate indicating that the Intelligent Key is not nearby.

### OK or NG

- OK >> Inspection end.  
NG >> Check combination meter. Refer to [DI-5](#).

## "KEY" Warning Lamp (GREEN) Check

INFOID:000000004407756

### 1. CHECK WARNING LAMP OPERATION

#### With CONSULT-III

- Check "INDICATOR" in "ACTIVE TEST" mode with CONSULT-III.
- Select "BLUE ON".

"KEY" warning lamp (green) should illuminate.

#### Without CONSULT-III

# INTELLIGENT KEY SYSTEM

## < SERVICE INFORMATION >

1. Turn ignition switch OFF.
2. Ensure Intelligent Key is in your possession inside the vehicle.
3. While monitoring the combination meter warning lamps, push the ignition knob switch.
4. The "KEY" warning lamp (green) should illuminate indicating that the Intelligent Key is nearby.

### OK or NG

- OK >> Inspection end.  
NG >> Check combination meter. Refer to [DI-5](#).

## Hazard Function Check

INFOID:000000004407757

### 1.CHECK HAZARD WARNING LAMP

Does hazard warning lamp flash with hazard switch?

#### YES or NO

- YES >> Hazard warning lamp circuit is OK.  
NO >> Check hazard circuit. Refer to [LT-45](#).

## Check Horn Function

INFOID:000000004407758

First perform the "SELF-DIAG RESULTS" in "BCM" with CONSULT-III, then perform the trouble diagnosis of malfunction system indicated "SELF-DIAG RESULTS" of "BCM". Refer to [BCS-16, "CAN Communication Inspection Using CONSULT-III \(Self-Diagnosis\)"](#).

### 1.CHECK HORN FUNCTION

Does horn sound with horn switch?

#### YES or NO

- YES >> Horn circuit is OK.  
NO >> Check horn circuit. Refer to [WW-27](#).

## IPDM E/R Operation Check

INFOID:000000004407759

### 1.CHECK IPDM E/R INPUT SIGNAL

Check voltage between IPDM E/R harness connector E43 terminal 13 and ground.

**13 – Ground : Battery voltage**

#### OK or NG

- OK >> Replace IPDM E/R. Refer to [PG-27, "Removal and Installation of IPDM E/R"](#).  
NG >> GO TO 2.

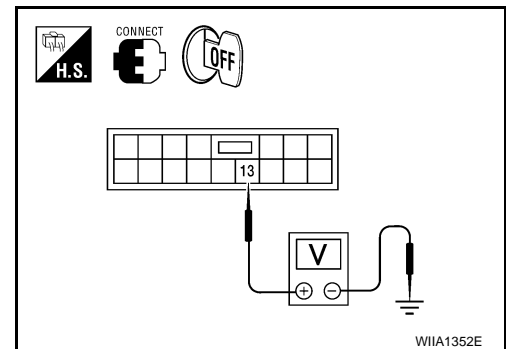

### 2.CHECK IPDM E/R CIRCUIT

1. Turn ignition switch OFF.
2. Disconnect IPDM E/R and horn relay connector.
3. Check continuity between IPDM E/R harness connector E43 (A) terminal 13 and horn relay harness connector H-1 (B) terminal 1.

# INTELLIGENT KEY SYSTEM

< SERVICE INFORMATION >

13 - 1

: Continuity should exist.

OK or NG

- OK >> Check harness connection.
- NG >> Repair or replace harness.

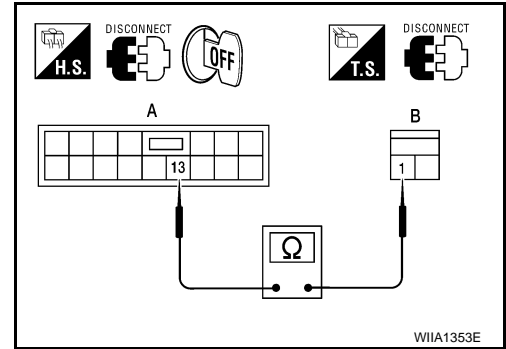

## Intelligent Key Battery Replacement

INFOID:000000004407760

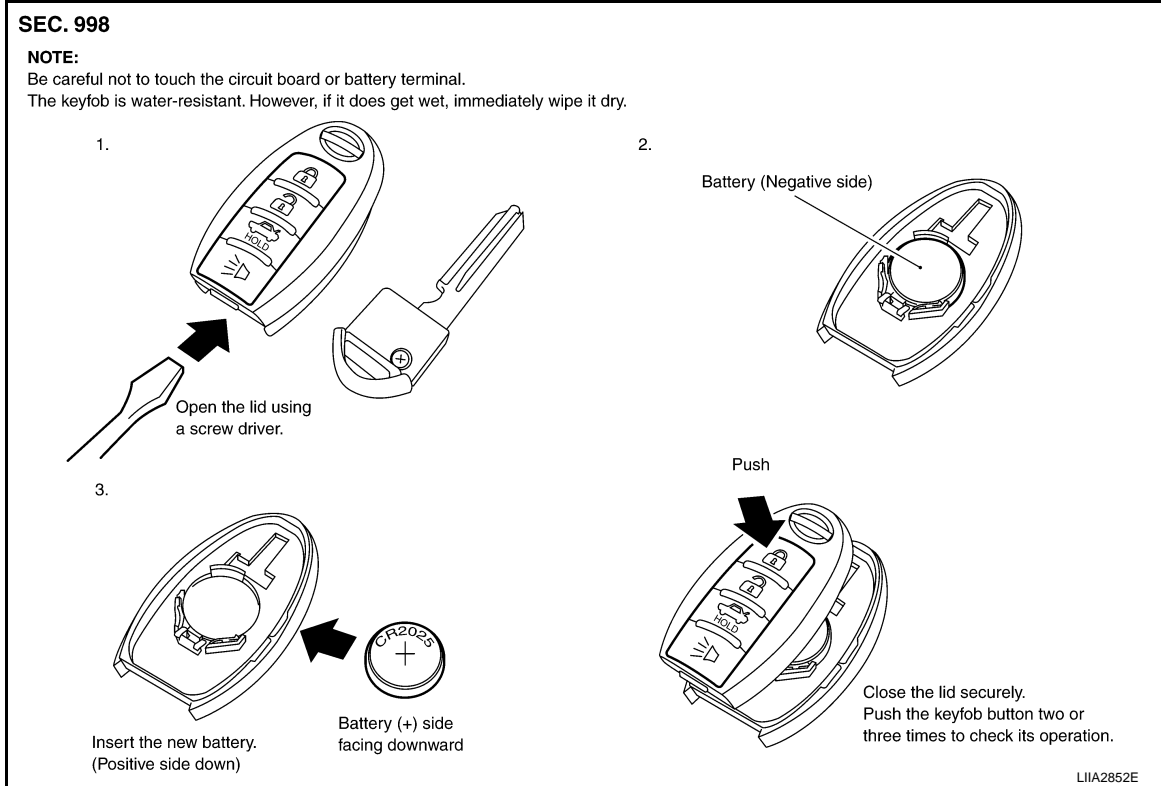

## INTELLIGENT KEY BATTERY INSPECTION

- Remove battery to measure voltage across battery positive (+) and negative (-) terminals.
- Check by connecting a resistance (approximately 300Ω) so that the current value becomes about 10 mA.

**Standard** : Approx. 2.5 - 3.0V

**NOTE:**

Key fob does not function if battery is not installed correctly.

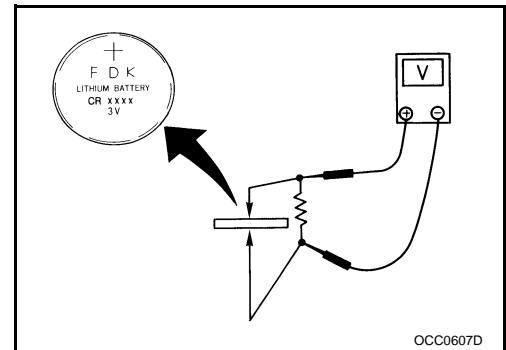

## Remote Keyless Entry Function

INFOID:000000004407761

### 1. CHECK KEYFOB FUNCTION

# INTELLIGENT KEY SYSTEM

## < SERVICE INFORMATION >

Check keyfob function using Remote Keyless Entry Tester J-43241.

Does the test pass?

### YES or NO

YES >> Keyfob is OK.

NO >> Replace keyfob. Refer to [BL-72, "System Description"](#).

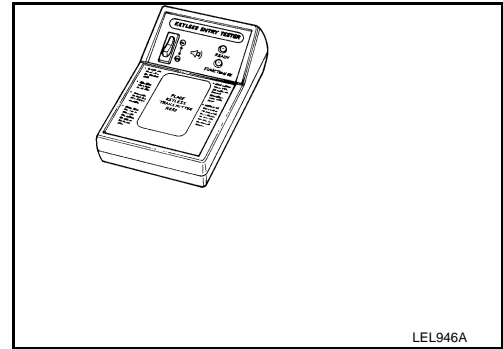

LEL946A

INFOID:000000004407762

## Removal and Installation of Intelligent Key Unit

### REMOVAL

1. Disconnect the battery negative terminal.
2. Remove the glove box assembly. Refer to [IP-12, "Removal and Installation"](#).
3. Remove the screw (a), disconnect and remove the Intelligent Key unit (1).

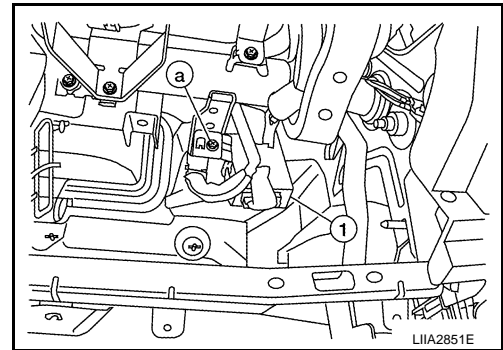

LIA2851E

### INSTALLATION

Installation is in the reverse order of removal.

# DOOR

< SERVICE INFORMATION >

## DOOR

### Fitting Adjustment

INFOID:000000004407763

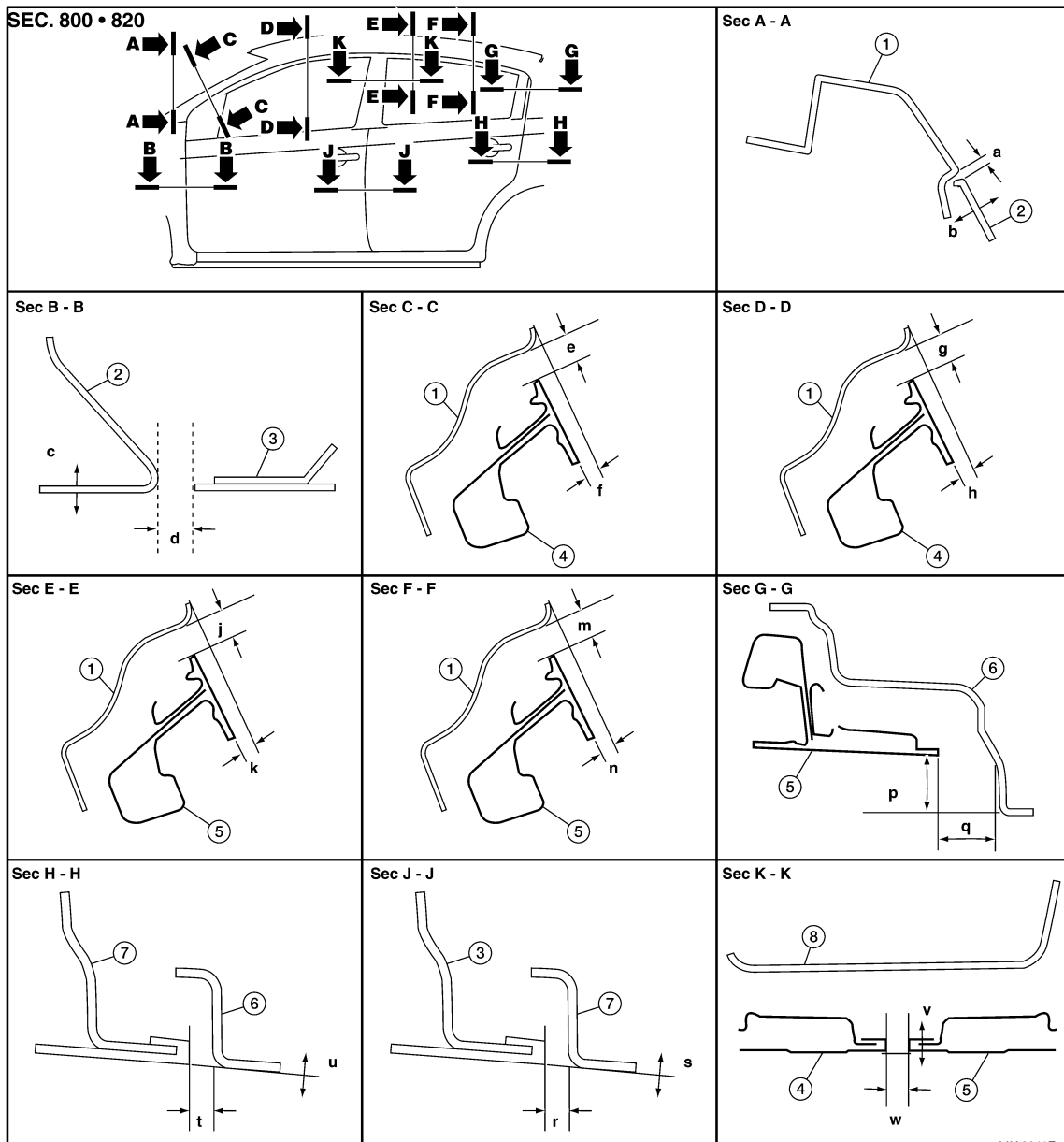

LIA2611E

- |   |   |   |
|---|---|---|
| 1. Body side outer                          | 2. Front fender                             | 3. Front door outer                         |
| 4. Front door sash                          | 5. Rear door sash                           | 6. Rear pillar                              |
| 7. Rear door outer                          | 8. Center pillar                            | a. $2.0 \pm 1.0$ mm ( $0.08 \pm 0.04$ in)   |
| b. $0.0 \pm 1.0$ mm ( $0.0 \pm 0.04$ in)    | c. $0.0 \pm 1.0$ mm ( $0.0 \pm 0.04$ in)    | d. $4.6 \pm 1.0$ mm ( $0.18 \pm 0.04$ in)   |
| e. $7.0 \pm 1.0$ mm ( $0.28 \pm 0.04$ in)   | f. $-3.6 \pm 1.5$ mm ( $-0.14 \pm 0.06$ in) | g. $6.8 \pm 1.0$ mm ( $0.27 \pm 0.04$ in)   |
| h. $-5.5 \pm 1.5$ mm ( $-0.22 \pm 0.06$ in) | j. $6.8 \pm 1.0$ mm ( $0.27 \pm 0.04$ in)   | k. $-5.3 \pm 1.5$ mm ( $-0.21 \pm 0.06$ in) |
| m. $7.0 \pm 1.0$ mm ( $0.28 \pm 0.04$ in)   | n. $-4.7 \pm 2.0$ mm ( $-0.19 \pm 0.08$ in) | p. $-8.9 \pm 2.0$ mm ( $-0.35 \pm 0.08$ in) |
| q. $22.1 \pm 1.0$ mm ( $0.87 \pm 0.04$ in)  | r. $4.5 \pm 1.0$ mm ( $0.18 \pm 0.04$ in)   | s. $0.0 \pm 1.0$ mm ( $0.0 \pm 0.04$ in)    |
| t. $4.6 \pm 1.0$ mm ( $0.18 \pm 0.04$ in)   | u. $0.0 \pm 1.0$ mm ( $0.0 \pm 0.04$ in)    | v. $0.0 \pm 1.0$ mm ( $0.0 \pm 0.04$ in)    |
| w. $5.5 \pm 1.5$ mm ( $0.22 \pm 0.06$ in)   |   |   |

FRONT DOOR

# DOOR

## < SERVICE INFORMATION >

### Longitudinal Clearance

1. Remove the front fender. Refer to [BL-19](#).
2. Loosen the front door hinge bolts.
3. Install the front fender. Refer to [BL-19](#).
4. Open the front door and adjust up or down at the rear edge according to specification.
5. Remove the front fender. Refer to [BL-19](#).
6. Tighten the front door hinge bolts.

**Front door hinge bolts**     **23.7 N-m (2.4 kg-m, 17 ft-lb)**

7. Install the front fender. Refer to [BL-19](#).

### Surface Height Adjustment

1. Loosen the front door hinge nuts.
2. Adjust the surface height difference of the fender and the front door according to specification.
3. Tighten the front door hinge nuts. Refer to [BL-132, "Removal and Installation"](#).

### Striker Adjustment

- 1.

**Striker screws**     **16.7 N-m (1.7 kg-m, 12 ft-lb)**

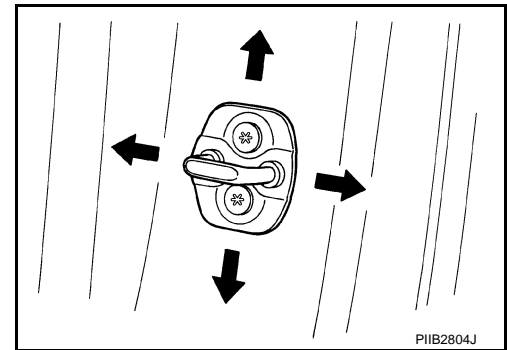

## REAR DOOR

### Longitudinal Clearance

1. Remove the center pillar upper and lower garnishes. Refer to [EI-33](#).
2. Open the front door and loosen the rear door hinge bolts.
3. From inside the vehicle, loosen the upper hinge nut. Open the rear door, and raise or lower the rear door at the rear edge according to specification.
4. Tighten the rear door hinge bolts and nut.

**Rear door hinge bolts**     **23.7 N-m (2.4 kg-m, 17 ft-lb)**

**Rear door hinge to center pillar nut**     **28.8 N-m (2.9 kg-m, 21 ft-lb)**

5. Install the center pillar upper and lower garnishes. Refer to [EI-33](#).

### Surface Height Adjustment

1. Loosen the rear door hinge nuts.
2. Adjust the surface height difference of front and rear doors according to specification.
3. Tighten the rear door hinge nuts. Refer to [BL-132, "Removal and Installation"](#).

### Striker Adjustment

# DOOR

## < SERVICE INFORMATION >

1.

**Striker screws**

**16.7 N·m (1.7 kg-m, 12 ft-lb)**

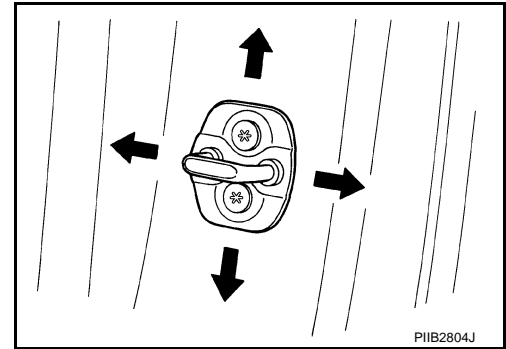

## Removal and Installation

INFOID:000000004407764

### FRONT DOOR

#### **CAUTION:**

- When removing and installing the front door assembly, support the door with a jack and cloth to protect the door and body.
- When removing and installing front door assembly, be sure to carry out the fitting adjustment. Refer to [BL-130, "Fitting Adjustment"](#).
- After installing, apply touch-up paint onto the head of the hinge nuts.
- Check the hinge rotating part for lubrication. If necessary, apply "body grease".
- Operate with two workers, because of its heavy weight.
- Check front door open/close operation after installation.

#### Removal

1. Remove dash side finisher. Refer to [EI-33, "Removal and Installation"](#).
2. Disconnect the front door harness connectors.
3. Remove the front door harness grommet, and then remove the harness from the front pillar.
4. Remove the check link bolt from the front pillar.

**Front door check link bolt 14.7 N·m (1.5 kg-m, 11 ft-lb)**

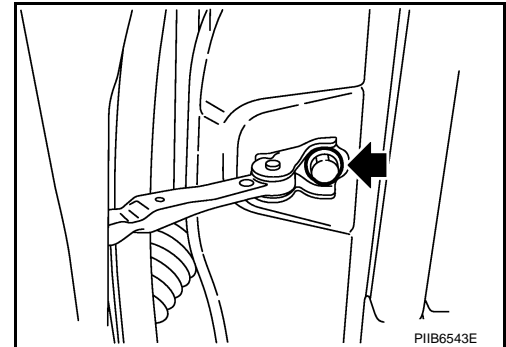



# DOOR

## < SERVICE INFORMATION >

5. Remove the front door hinge nuts (a) and the door assembly (1).

Front door hinge nuts

28.0 N·m (2.9 kg-m, 21 ft-lb)

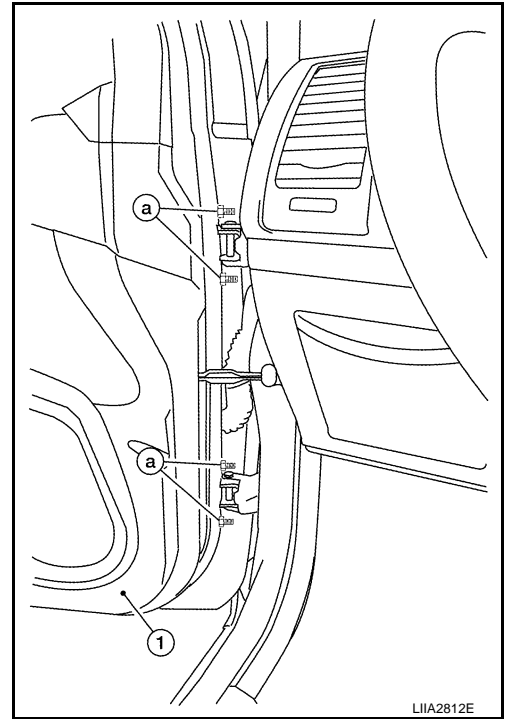

### Installation

Installation is in the reverse order of removal.

### REAR DOOR

#### CAUTION:

- When removing and installing the rear door assembly, support the door with a jack and cloth to protect the door and body.
- When removing and installing rear door assembly, be sure to carry out the fitting adjustment. Refer to [BL-130. "Fitting Adjustment"](#).
- After installing, apply touch-up paint onto the head of the hinge nuts.
- Check the hinge rotating part for poor lubrication. If necessary, apply "body grease".
- Operate with two workers, because of its heavy weight.
- Check rear door open/close operation after installation.

### Removal

1. Remove the rear door harness grommet.

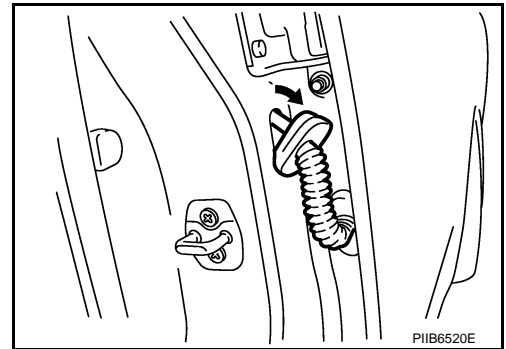

## DOOR

### < SERVICE INFORMATION >

2. Disconnect the rear door harness connector.

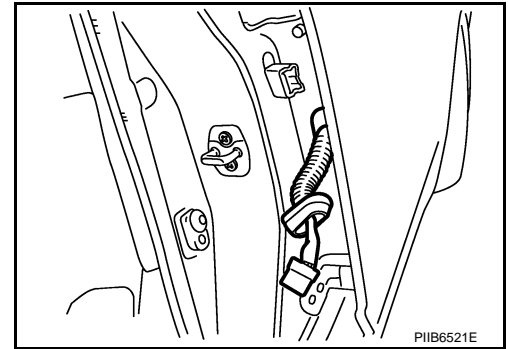

3. Remove the check link bolt from the center pillar.

**Rear door check link bolt** 14.7 N·m (1.5 kg·m, 11 ft·lb)

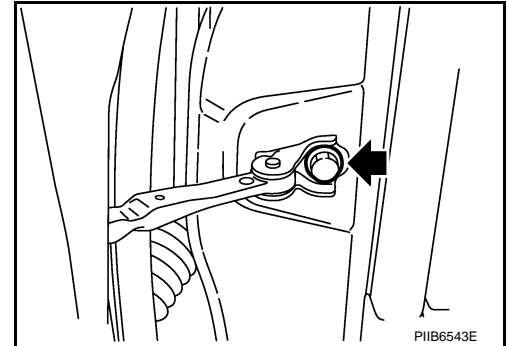

4. Remove the rear door hinge nuts (a) and the door assembly (1).

**Rear door hinge nuts** 28.0 N·m (2.9 kg·m, 21 ft·lb)

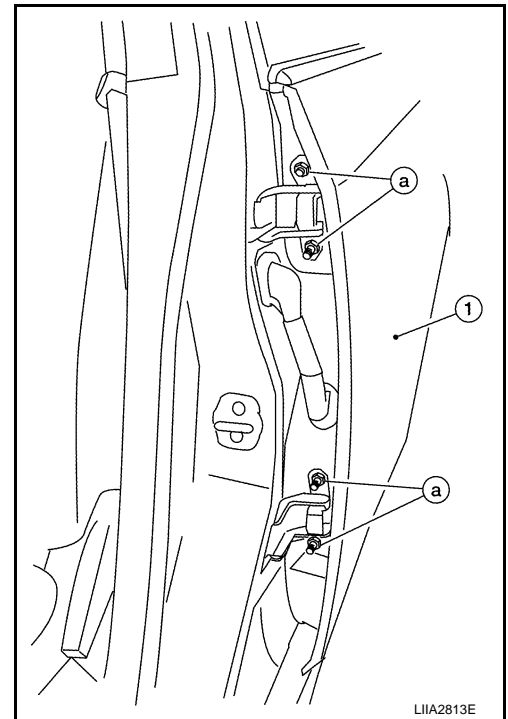

#### Installation

Installation is in the reverse order of removal.

# FRONT DOOR LOCK

< SERVICE INFORMATION >

## FRONT DOOR LOCK

### Component Parts Location

INFOID:000000004407765

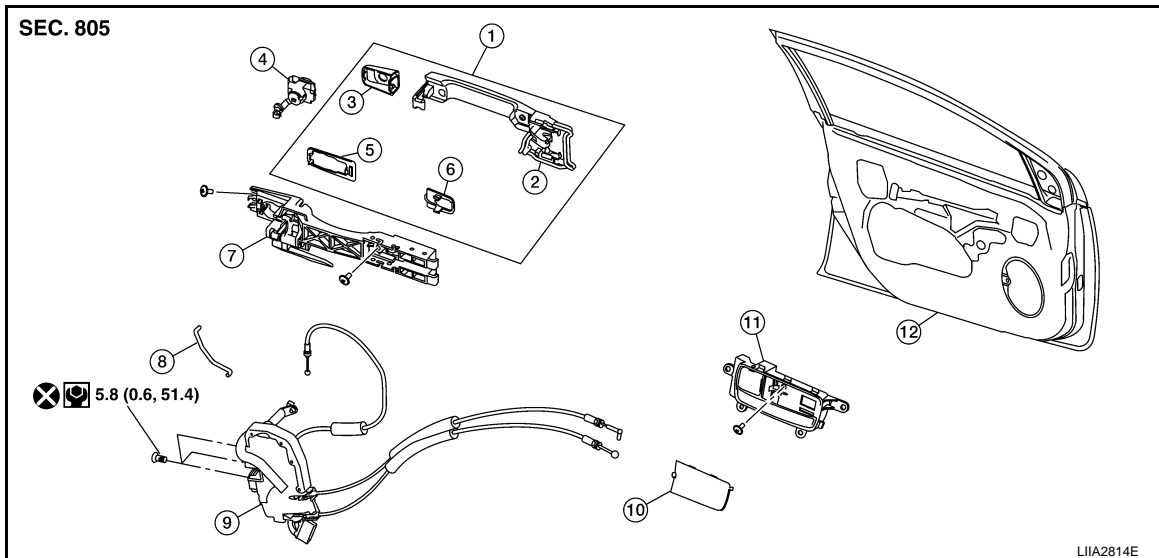

- |                                       |                                       |   |
|---------------------------------------|---------------------------------------|---|
| 1. Front door outside handle assembly | 2. Front door outside handle assembly | 3. Door key cylinder assembly (Driver's side)<br>Outside handle escutcheon (passenger's side) |
| 4. Key cylinder assembly              | 5. Rear gasket                        | 6. Front gasket   |
| 7. Outside handle bracket             | 8. Key cylinder connecting rod        | 9. Door lock assembly   |
| 10. Inside door handle cap            | 11. Inside door handle assembly       | 12. Front door assembly   |

### Removal and Installation

INFOID:000000004407766

#### REMOVAL

1. Remove front door finisher. Refer to [EI-30, "Removal and Installation"](#).
2. Temporarily reconnect the battery and the power window switch. Fully close front door window.
3. Disconnect the battery negative terminal and remove the power window switch.
4. Remove the front door sealing screen.

#### NOTE:

If the sealing screen is to be reused, pull it and the adhesive at approximately a 30 degree angle from the metal to remove it cleanly.

5. Remove front door rear glass run channel. Refer to [GW-47](#).
6. Remove the door side grommet, and the door key cylinder mask (escutcheon) bolt.
7. Disconnect the key cylinder connecting rod (key cylinder side).
8. If equipped, disconnect the door antenna, the door request switch connector and remove the harness clamp. (Vehicle with intelligent key systems only).

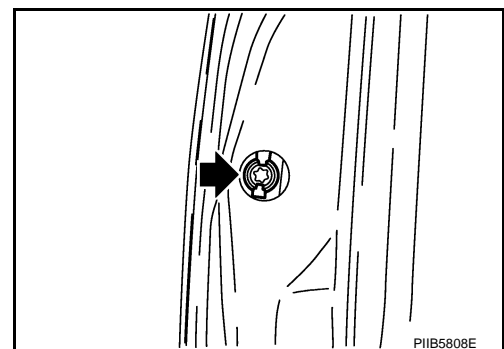

# FRONT DOOR LOCK

## < SERVICE INFORMATION >

9. Remove the door cylinder and mask assembly while pulling the outside handle forward.

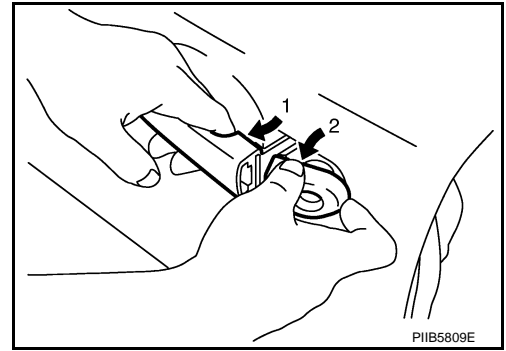

10. Pull the outside door handle out and then slide it toward the rear of the vehicle to remove.

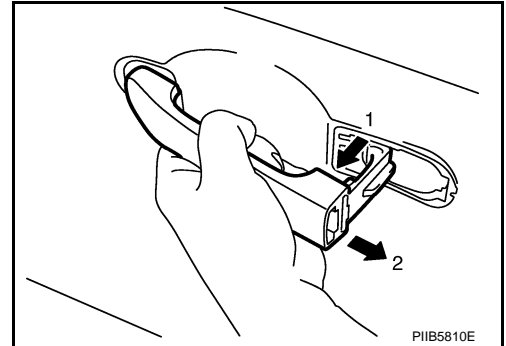

11. Remove the front and rear gaskets.

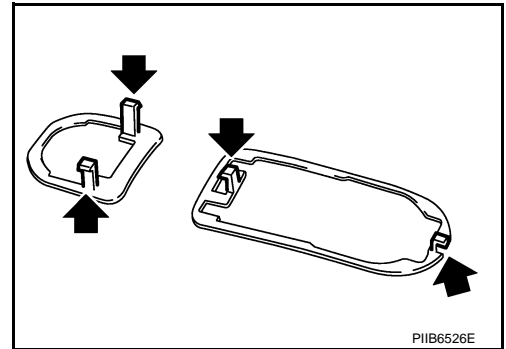

12. Remove the door lock assembly bolts.

**5.8 N·m (0.6 kg-m, 51.4 in-lb)**

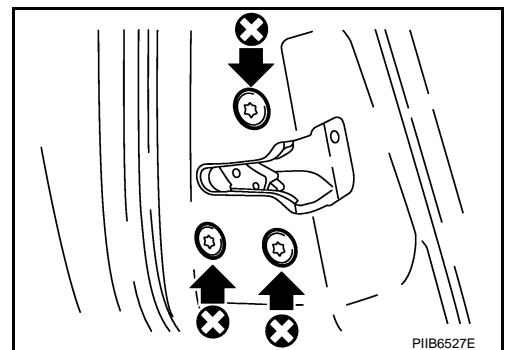

13. Slide the outside handle bracket toward the rear of the vehicle, and remove the assembly.

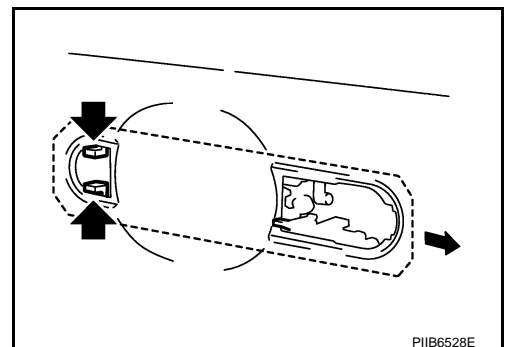

## FRONT DOOR LOCK

### < SERVICE INFORMATION >

14. If equipped, disconnect the door lock assembly electrical connector.
15. Separate the outside handle cable from the outside handle bracket.

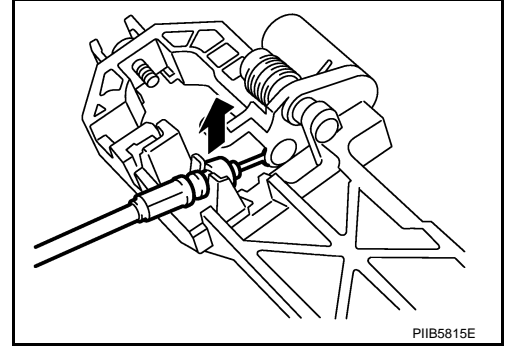

### INSTALLATION

Installation is in the reverse order of removal.

#### **CAUTION:**

- To install the rod, be sure to rotate the rod holders until a click is felt.

A  
B  
C  
D  
E  
F  
G  
H  
J  
K  
L  
M  
N  
O  
P

BL

# REAR DOOR LOCK

< SERVICE INFORMATION >

## REAR DOOR LOCK

### Component Parts Location

INFOID:000000004407767

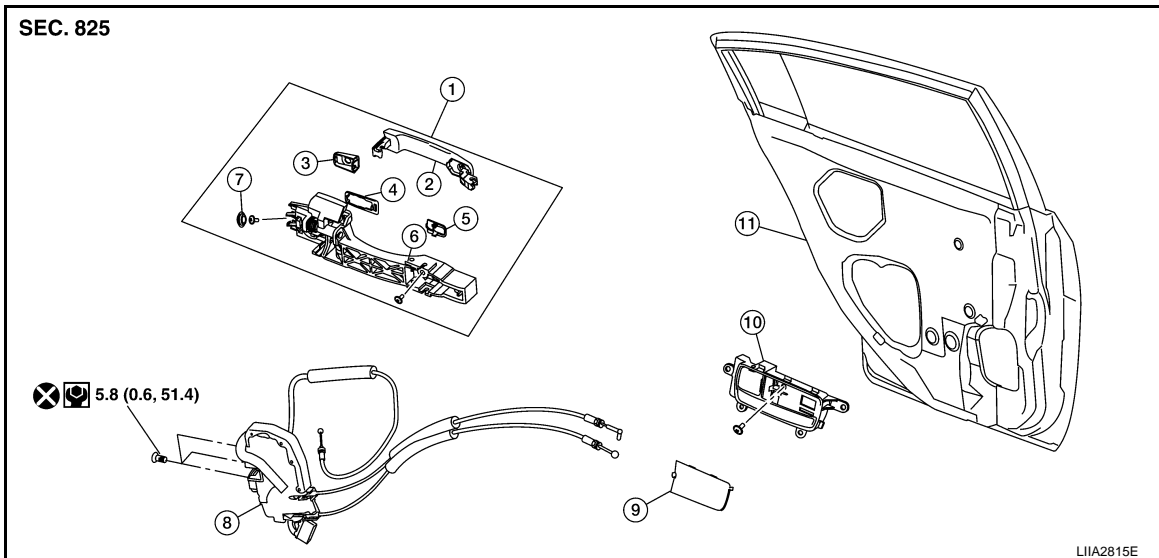

- |                                 |                            |                              |
|---------------------------------|----------------------------|------------------------------|
| 1. Outside door handle assembly | 2. Outside handle          | 3. Outside handle escutcheon |
| 4. Rear gasket                  | 5. Front gasket            | 6. Outside handle bracket    |
| 7. Grommet                      | 8. Rear door lock assembly | 9. Inside door handle cap    |
| 10. Inside door handle assembly | 11. Rear door assembly     |                              |

### Removal and Installation

INFOID:000000004407768

#### REMOVAL

1. Remove the partition glass. Refer to [GW-51](#).
2. Support door glass while lifting it up to the door window completely closed position.
3. Remove the door side grommet, and the outside handle escutcheon screw.

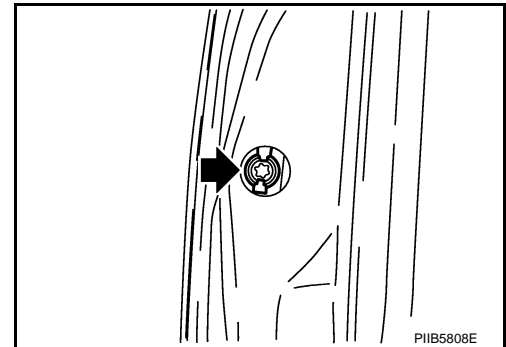

4. Pull the outside handle forward (1), while removing outside handle escutcheon (2).

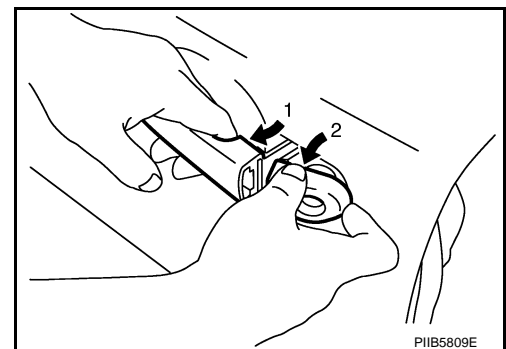

# REAR DOOR LOCK

## < SERVICE INFORMATION >

5. Pull outside door handle forward (1), and slide it toward the rear of the vehicle to remove (2).

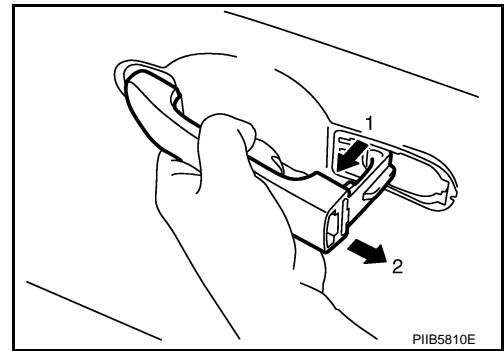

6. Remove the front and rear gaskets.

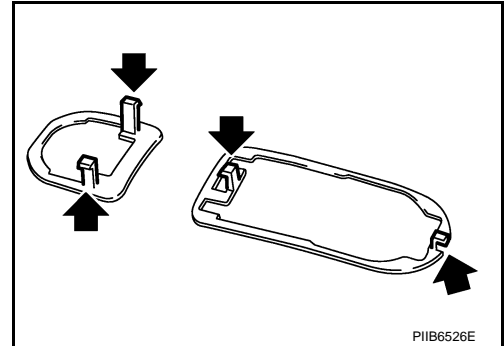

7. Remove the door lock assembly screws.

 : 5.8 N·m (0.6 kg-m, 51.4 in-lb)

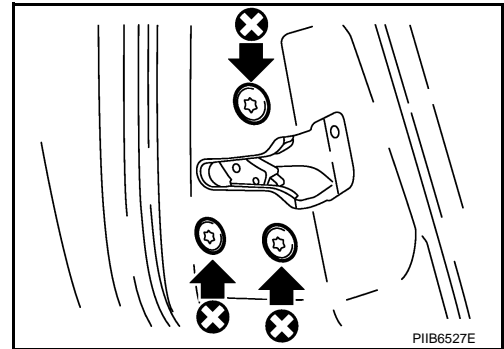

8. Slide the outside handle bracket toward the rear of vehicle, remove the outside handle bracket and the door lock assembly.

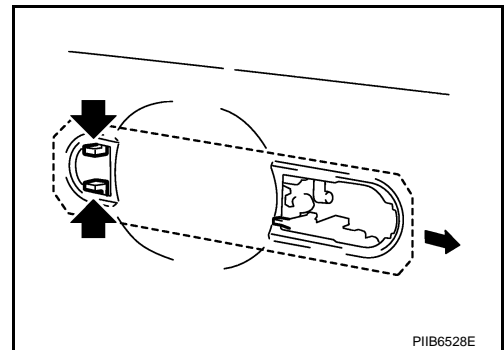

9. If equipped, disconnect the door lock assembly electrical connector.

A  
B  
C  
D  
E  
F  
G  
H  
BL  
J  
K  
L  
M  
N  
O  
P

## REAR DOOR LOCK

### < SERVICE INFORMATION >

10. Disconnect the outside handle cable from the outside handle bracket.

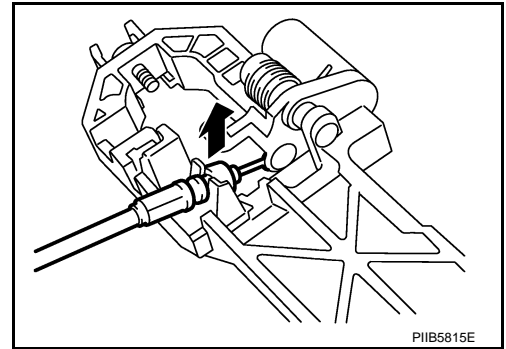

### INSTALLATION

Installation is in the reverse order of removal.



# TRUNK LID

< SERVICE INFORMATION >

## TRUNK LID

### Fitting Adjustment

INFOID:000000004407769

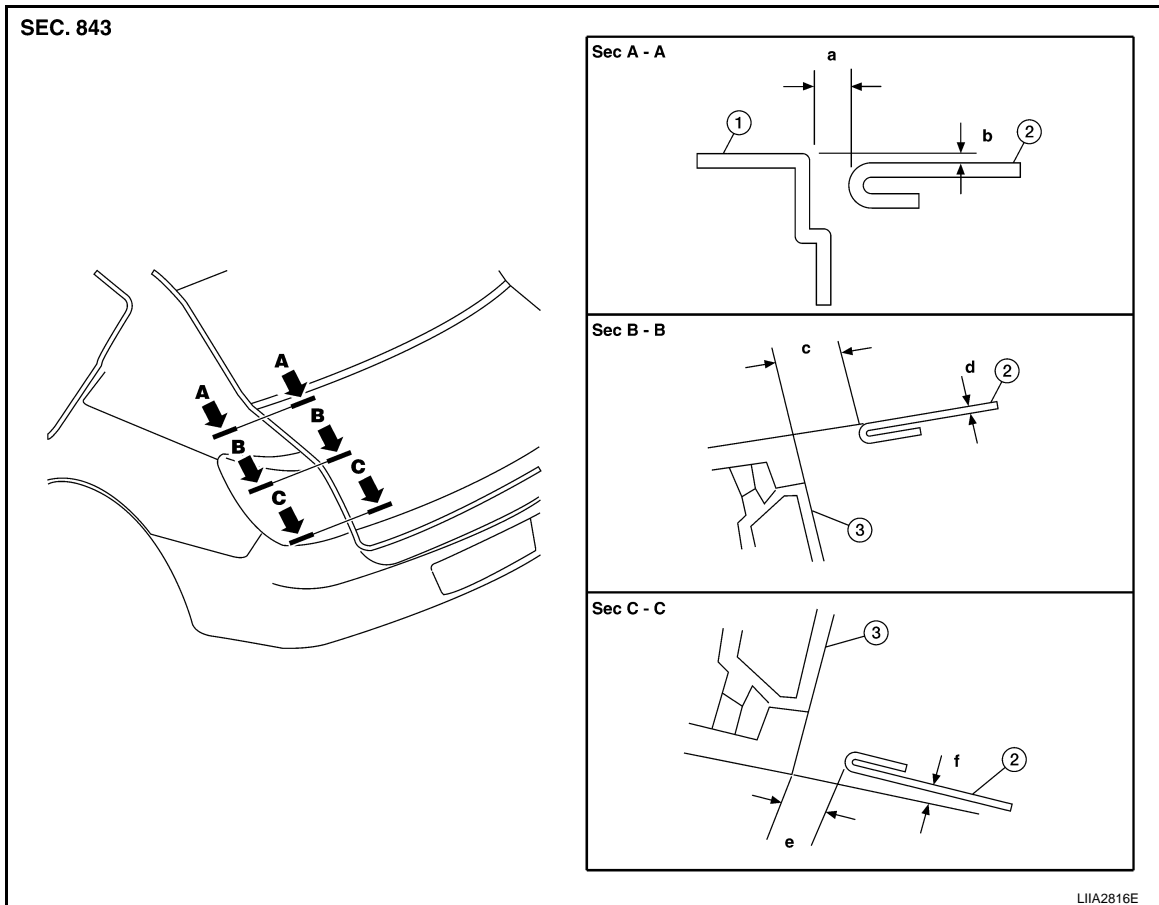

- |   |   |  |
|---|---|--|
| 1. Rear fender                            | 2. Trunk lid                              | 3. Rear combination lamp                   |
| a. $4.0 \pm 1.0$ mm ( $0.16 \pm 0.04$ in) | b. $0.0 \pm 1.0$ mm ( $0.0 \pm 0.04$ in)  | c. $4.0 \pm 1.6$ mm ( $0.16 \pm 0.06$ in)  |
| d. $0.8 \pm 1.6$ mm ( $0.03 \pm 0.06$ in) | e. $4.0 \pm 1.6$ mm ( $0.16 \pm 0.06$ in) | f. $1.25 \pm 1.6$ mm ( $0.05 \pm 0.06$ in) |

#### Longitudinal and lateral clearance adjustment

1. With the striker released, loosen the trunk lid hinge nuts and close the trunk lid.
2. Make the lateral clearance and the clearance to the rear window glass equal. Then open the trunk lid to tighten the nuts.

#### Surface height adjustment

1. Loosen the striker bolts. Raise the striker to the top position, and temporarily tighten the upper bolt.
2. Close the trunk lid lightly and adjust the surface height. Then open the trunk lid and tighten the striker bolts.

#### Trunk Lid Assembly

INFOID:000000004407770

#### REMOVAL

1. Remove the trunk lid finisher. Refer to [EI-43](#).
2. Remove the trunk lid wire harness.

A  
B  
C  
D  
E  
F  
G  
H  
BL  
J  
K  
L  
M  
N  
O  
P

# TRUNK LID

## < SERVICE INFORMATION >

3. Remove the nuts (a) and the trunk lid assembly (1).

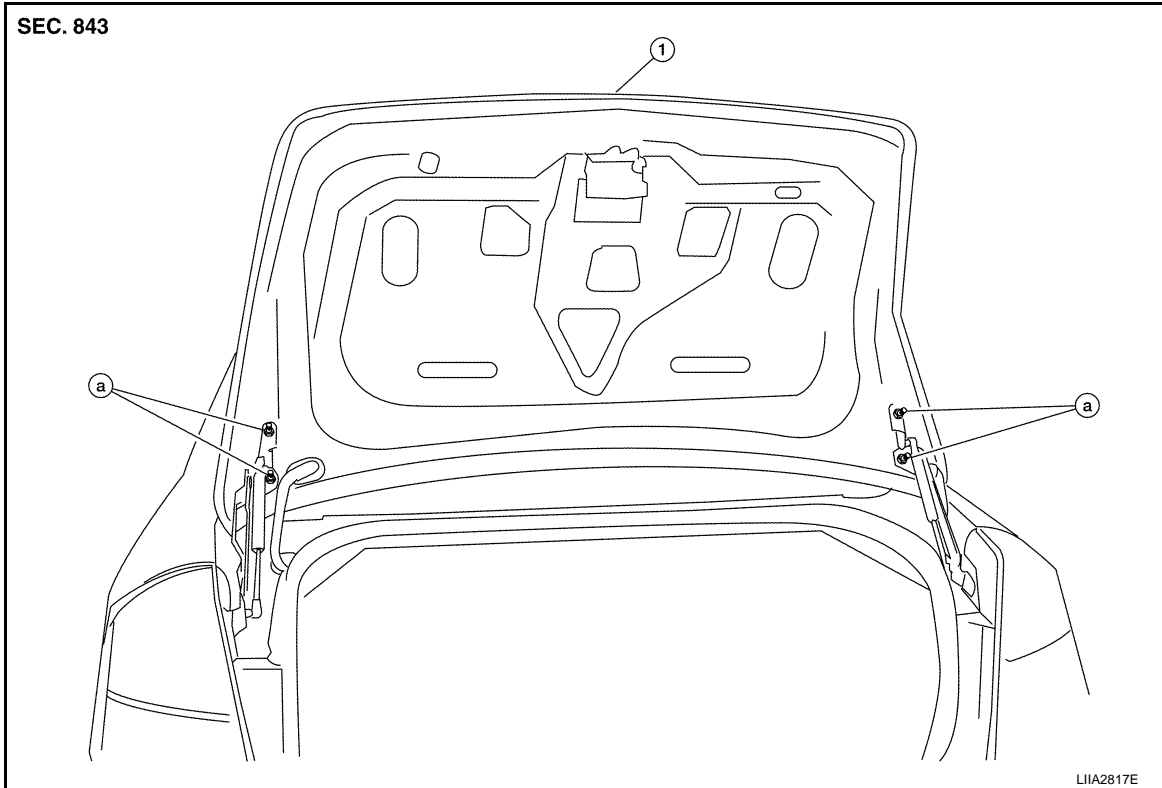

### INSTALLATION

Installation is in the reverse order of removal.

#### **CAUTION:**

**After installing, apply touch-up paint (body color) to the head of the hinge nuts.**

### Trunk Lid Lock

INFOID:000000004407771

### REMOVAL

1. Remove the trunk lid finisher. Refer to [EI-43](#) .
2. If equipped, disconnect the trunk lid lock cylinder rod.
3. Remove the release cable.
4. Remove the bolts (a) and the trunk lid lock (1).

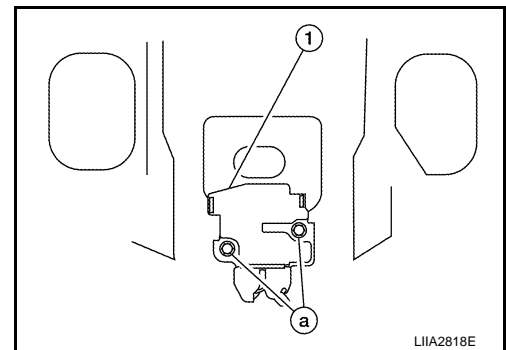

### INSTALLATION

Installation is in the reverse order of removal.

### Trunk Lid Striker

INFOID:000000004407772

### REMOVAL

1. Remove the trunk rear plate and trunk rear finisher. Refer to [EI-43](#) .
2. Remove the bolts, disconnect the electrical connector and remove the trunk lock actuator.
3. Remove the bolt and disconnect the trunk lid release cable.

# TRUNK LID

## < SERVICE INFORMATION >

4. Remove the bolts (a) and the trunk lid striker (1).

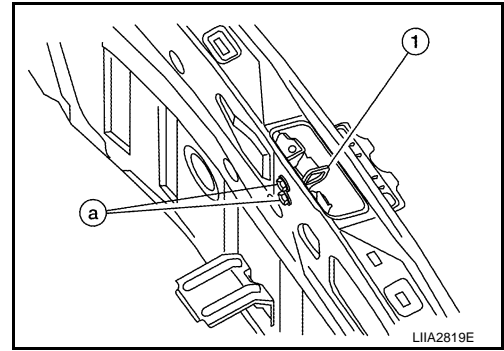

## INSTALLATION

Installation is in the reverse order of removal.

A  
B  
C  
D  
E  
F  
G  
H  
BL  
J  
K  
L  
M  
N  
O  
P

# TRUNK LID OPENER

< SERVICE INFORMATION >

## TRUNK LID OPENER

### Component Parts and Harness Connector Location

INFOID:000000004407773

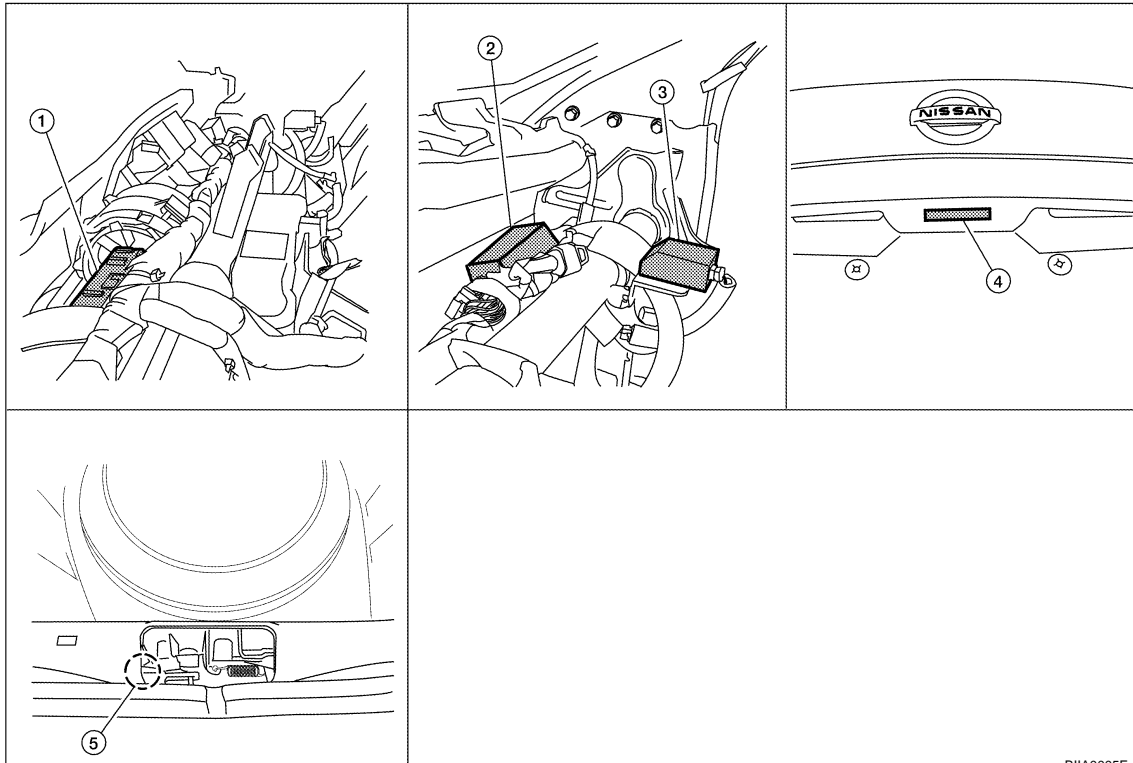

B1IA0005E

- |  |   |   |
|--|---|---|
| 1. BCM M18, M19, M20<br>(view with instrument panel removed) | 2. Intelligent Key unit M42<br>(with Intelligent Key)<br>(view with instrument panel removed) | 3. Remote keyless entry receiver M15<br>(without Intelligent Key) |
| 4. Trunk opener request switch T5<br>(with Intelligent Key)  | 5. Trunk lid opener actuator B59  |   |

### System Description

INFOID:000000004407774

Power is supplied at all times

- through 50A fusible link (letter j, located in fuse and fusible link box)
- to BCM terminal 70
- through 10A fuse [No. 21, located in fuse block (J/B)]
- to BCM terminal 57
- through 10A fuse [No. 9, located in fuse block (J/B)]
- to Intelligent Key unit terminal 11 (with Intelligent Key).

Ground is supplied

- to BCM terminal 67 and
- to Intelligent Key unit terminal 12 (with Intelligent Key)
- through body grounds M57 and M61.

Then power is supplied

- through BCM terminal 53
- to trunk lid opener actuator terminal 1.

Ground is supplied

- to trunk lid opener actuator terminal 2
- through body grounds B7 and B19.

Then BCM operates trunk lid opener actuator.

# TRUNK LID OPENER

< SERVICE INFORMATION >

## Wiring Diagram - TLID -

INFOID:000000004407775

WITHOUT INTELLIGENT KEY

BL-TLID-01

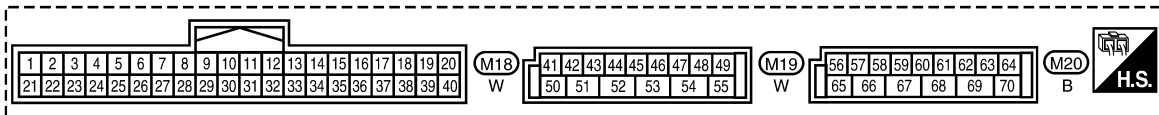
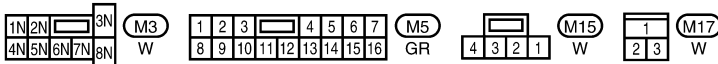
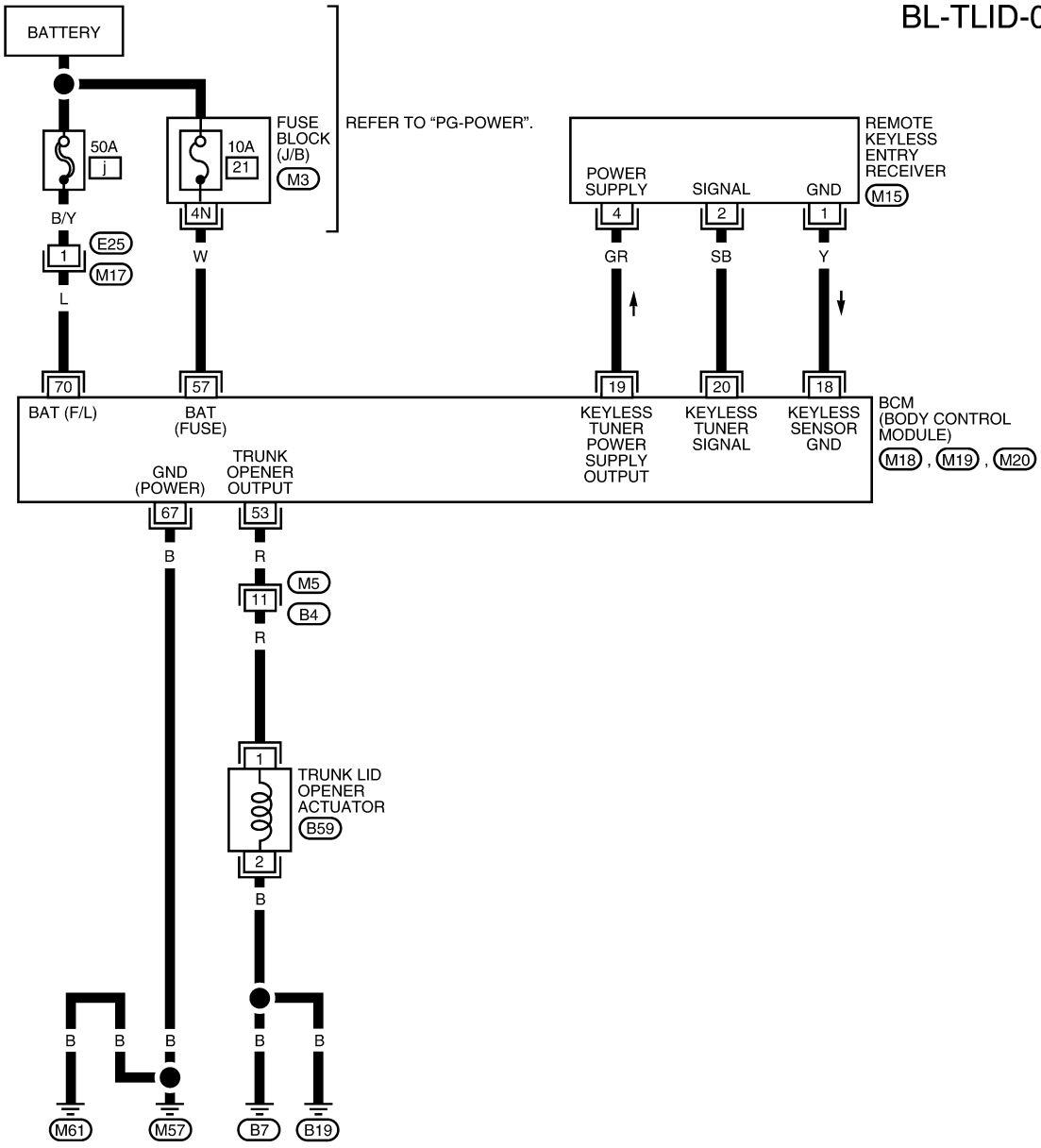

WIWA2204E

# TRUNK LID OPENER

< SERVICE INFORMATION >  
WITH INTELLIGENT KEY

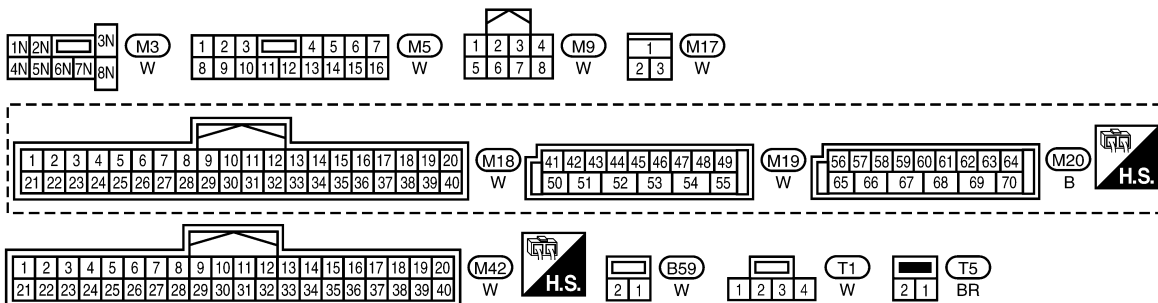
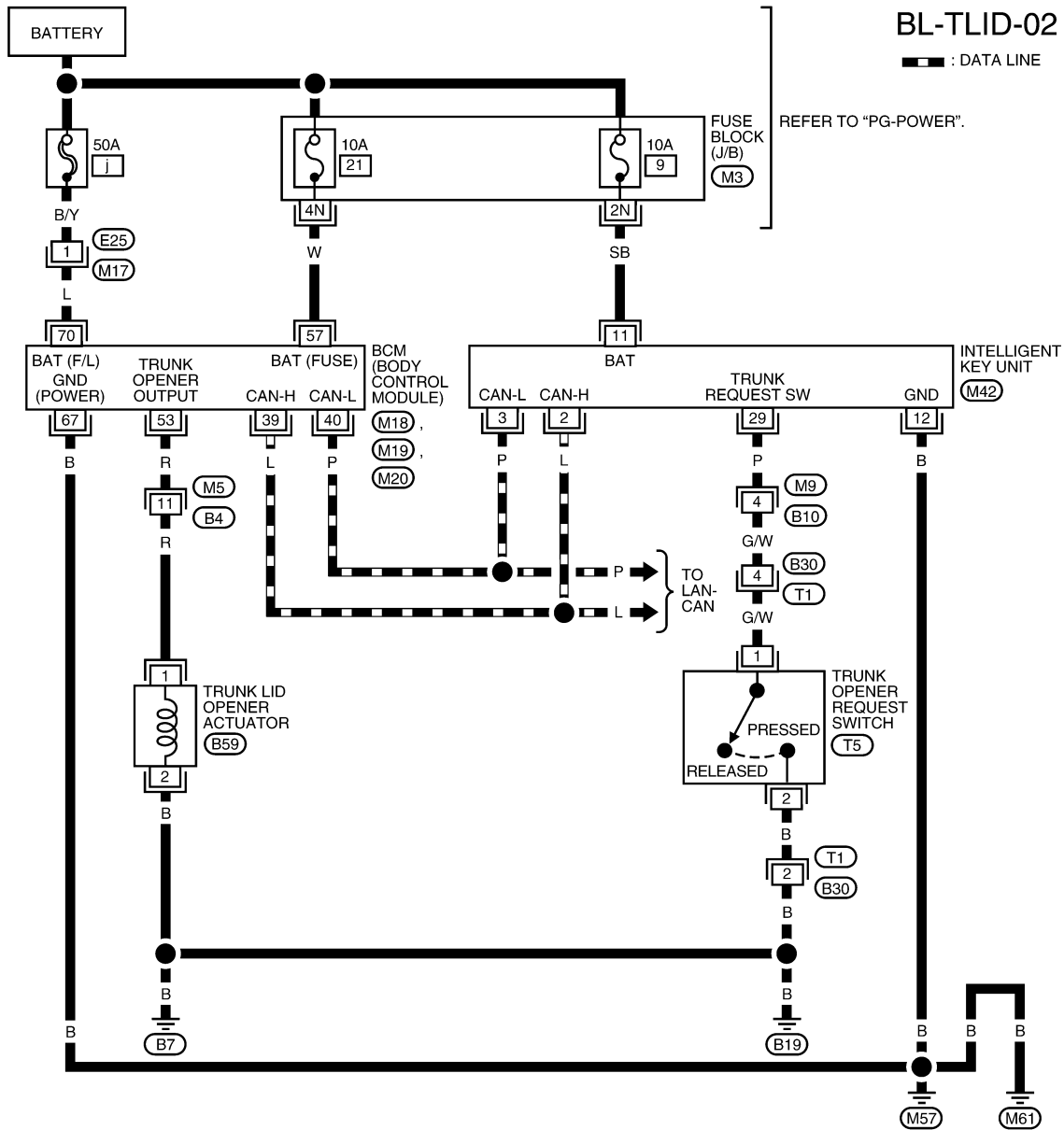

AWKWA0101GI

INFOID:000000004407776

Terminal and Reference Value for BCM

Refer to [BCS-11](#), "Terminal and Reference Value for BCM".

Terminal and Reference Value for Intelligent Key Unit

INFOID:000000004407777

Refer to [BL-92](#), "Terminal and Reference Value for Intelligent Key Unit".

# TRUNK LID OPENER

< SERVICE INFORMATION >

## CONSULT-III Function (BCM)

INFOID:000000004407778

CONSULT-III can display each diagnostic item using the diagnostic test modes shown following.

BCM diagnostic test item	Diagnostic mode	Description
Inspection by part	WORK SUPPORT	Supports inspections and adjustments. Commands are transmitted to the BCM for setting the status suitable for required operation, input/output signals are received from the BCM and received date is displayed.
	DATA MONITOR	Displays BCM input/output data in real time.
	ACTIVE TEST	Operation of electrical loads can be checked by sending drive signal to them.
	SELF-DIAG RESULTS	Displays BCM self-diagnosis results.
	CAN DIAG SUPPORT MNTR	The result of transmit/receive diagnosis of CAN communication can be read.
	ECU PART NUMBER	BCM part number can be read.
	CONFIGURATION	Performs BCM configuration read/write functions.

## CONSULT-III APPLICATION ITEMS

### Data Monitor

Monitor item	Content
IGN ON SW	Indicates [ON/OFF] condition of ignition switch.
KEYLESS TRUNK**	Indicates [ON/OFF] condition of trunk release signal from keyfob.
I-KEY TRUNK*	Momentarily indicates [ON/OFF] condition of trunk open signal from trunk opener request switch.
VEHICLE SPEED	Indicates vehicle speed.

\* : With Intelligent Key system

\*\* : Without Intelligent Key system

### Active Test

Test item	Content
TRUNK/BACK DOOR	This test is able to check trunk lid opener actuator unlock operation. Actuator opens trunk lock assembly when "OPEN" on CONSULT-III screen is touched.

## Work Flow

INFOID:000000004407779

1. Check the symptom and customer's requests.
2. Understand the outline of system. Refer to [BL-144. "System Description"](#).
3. Repair or replace any malfunctioning parts. Refer to [BL-148. "Trouble Diagnosis Chart by Symptom"](#).
4. Does trunk lid opener operate normally? If Yes, GO TO 5. If No, GO TO 3.
5. Inspection end.

# TRUNK LID OPENER

< SERVICE INFORMATION >

## Trouble Diagnosis Chart by Symptom

INFOID:000000004407780

Symptom	Diagnoses/service procedure	Reference page
Trunk lid release switch does not operate. (Without Intelligent Key system)	1. Check BCM power supply and ground circuit.	<a href="#">BCS-14</a>
	2. Check keyfob battery and function. <b>NOTE:</b> If the result of keyfob function check with CONSULT-III is OK, keyfob is not malfunctioning.	<a href="#">BL-60</a>
	3. Check remote keyless entry receiver.	<a href="#">BL-65</a>
	4. Check trunk lid opener actuator.	<a href="#">BL-150</a>
	5. Replace BCM.	<a href="#">BCS-17</a>
Trunk lid release does not operate. (With Intelligent Key system)	1. Check Intelligent Key power supply and ground circuit.	<a href="#">BL-106</a>
	2. Check BCM power supply and ground circuit.	<a href="#">BCS-14</a>
	3. Intelligent Key battery inspection check.	<a href="#">BL-128</a>
	4. Remote Keyless Entry Function check.	<a href="#">BL-128</a>
	5. Check trunk opener request switch.	<a href="#">BL-148</a>
	6. Check trunk lid opener actuator.	<a href="#">BL-150</a>
	7. Replace Intelligent Key unit.	<a href="#">BL-129</a>

### Terminal and Reference Value for BCM

INFOID:000000004407781

Refer to [BCS-11](#), "Terminal and Reference Value for BCM".

### Terminal and Reference Value for Intelligent Key Unit

INFOID:000000004407782

Refer to [BL-92](#), "Terminal and Reference Value for Intelligent Key Unit".

### BCM Power Supply and Ground Circuit Inspection

INFOID:000000004407783

Refer to [BCS-14](#), "BCM Power Supply and Ground Circuit Inspection".

### Intelligent Key Unit Power Supply and Ground Circuit Inspection

INFOID:000000004407784

Refer to [BL-106](#), "Power Supply and Ground Circuit Inspection".

### Check Trunk Opener Request Switch Circuit (With Intelligent Key)

INFOID:000000004407785

#### 1. CHECK TRUNKOPENER REQUEST SWITCH SIGNAL

##### With CONSULT-III

Check trunk opener request switch ("I-KEY TRNK") in "DATA MONITOR" mode with CONSULT-III.

Test item	Condition
I-KEY TRNK	trunk opener request switch is pushed: ON (momentarily)
	trunk opener request switch is released: OFF

 Without CONSULT-III



# TRUNK LID OPENER

## < SERVICE INFORMATION >

Check voltage between Intelligent Key unit connector M42 terminal 29 and ground.

Terminals			Door condition	Voltage (V) (Approx.)	
(+)		(-)			
Intelligent Key unit connector	Terminal				
M42	29	Ground	trunk opener request switch	Pushed	0
			Released	5	

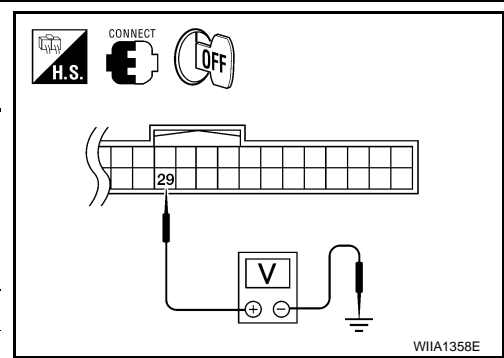

### OK or NG

- OK >> Trunk opener request switch is OK.
- NG >> GO TO 2.

## 2.CHECK TRUNK OPENER REQUEST SWITCH CIRCUIT 1

1. Turn ignition switch OFF.
2. Disconnect Intelligent Key unit and trunk opener request switch connector.
3. Check continuity between Intelligent Key unit connector M42 (A) terminal 29 and trunk opener request switch connector T5 (B) terminal 1.

A		B		Continuity
Intelligent Key unit connector	Terminal	Trunk opener request switch connector	Terminal	
M42	29	T5	1	Yes

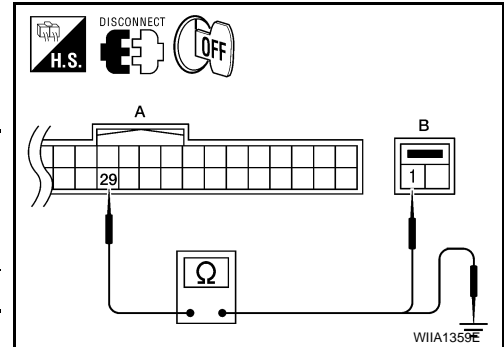

4. Check continuity between Intelligent Key unit connector M42 (A) terminal 29 and ground.

A		Ground	Continuity
Intelligent Key unit connector	Terminal		
M42	29		No

### OK or NG

- OK >> GO TO 3.
- NG >> Repair or replace harness.

## 3.CHECK TRUNK OPENER REQUEST SWITCH

Check continuity between trunk opener request switch terminals 1 and 2.

Terminal		Trunk opener request switch condition	Continuity
Trunk opener request switch			
1	2		
		Pushed	Yes
		Released	No

### OK or NG

- OK >> GO TO 4.
- NG >> Replace trunk opener request switch.

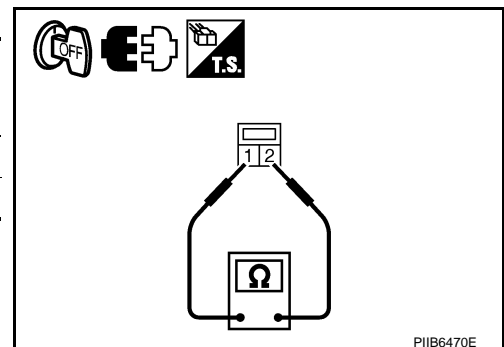

## 4.CHECK TRUNK OPENER REQUEST SWITCH GROUND CIRCUIT

# TRUNK LID OPENER

## < SERVICE INFORMATION >

Check continuity between trunk opener request switch connector terminal 2 and ground.

Trunk opener request switch connector	Terminal	Ground	Continuity
T5	2		Yes

### OK or NG

- OK >> GO TO 5.
- NG >> Repair or replace harness.

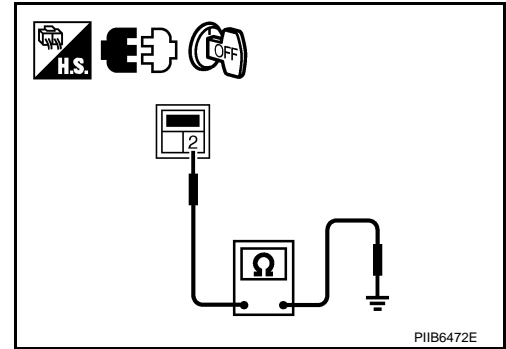

## 5. CHECK INTELLIGENT KEY UNIT OUTPUT SIGNAL

1. Connect Intelligent Key unit connector.
2. Check voltage between Intelligent Key unit connector M42 terminal 29 and ground.

Terminals		(-)	Voltage (V) (Approx.)
(+)	Terminal		
Intelligent Key unit connector	Terminal		
M42	29	Ground	5

### OK or NG

- OK >> Check the condition of harness and connector.
- NG >> Replace Intelligent Key unit. Refer to [BL-129. "Removal and Installation of Intelligent Key Unit"](#).

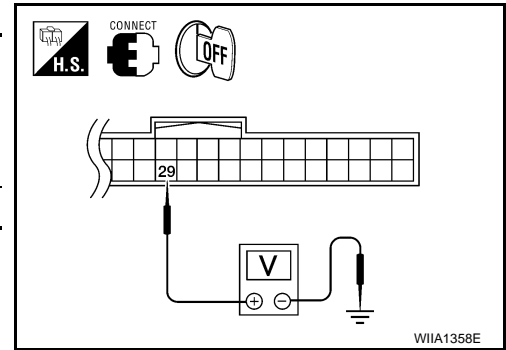

## Check Trunk Lid Opener Actuator Circuit

INFOID:000000004407786

## 1. CHECK TRUNK LID OPENER ACTUATOR FUNCTION

### Ⓟ With CONSULT-III

Check the operation with ("TRUNK/BACK DOOR") in the ACTIVE TEST.

**Does trunk lid opener actuator operate normally?**

### YES or NO

- YES >> Trunk lid opener actuator circuit is OK.
- NO >> GO TO 2.

## 2. CHECK TRUNK LID OPENER ACTUATOR POWER SUPPLY

1. Turn ignition switch OFF.
2. Disconnect trunk lid opener actuator connector.
3. Check voltage between trunk lid opener actuator connector B59 terminal 1 and ground.

Terminals		(-)	Condition	Voltage (V) (Approx.)
(+)	Terminal			
Trunk lid opener actuator connector	Terminal			
B59	1	Ground	Keyfob trunk release button	0 ↓ Battery voltage ↓ 0
			Released	0

### OK or NG

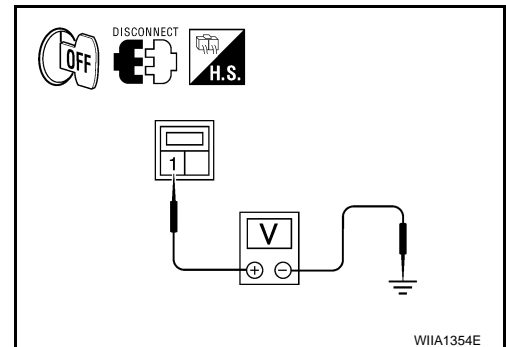

# TRUNK LID OPENER

## < SERVICE INFORMATION >

- OK >> GO TO 3.
- NG >> GO TO 4.

### 3. CHECK TRUNK LID OPENER ACTUATOR GROUND CIRCUIT

Check continuity between trunk lid opener actuator connector B59 terminal 2 and ground.

Trunk lid opener actuator connector	Terminal	Ground	Continuity
B59	2		Yes

#### OK or NG

- OK >> Replace trunk lid opener actuator. Refer to [BL-142](#), "[Trunk Lid Lock](#)".
- NG >> Repair or replace harness.

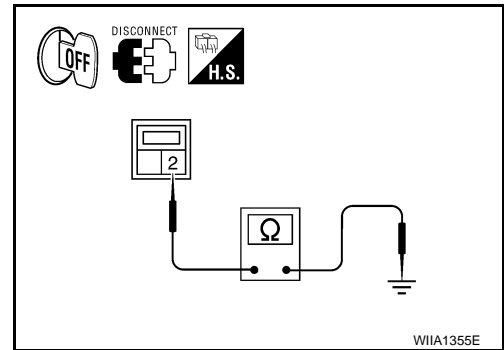

### 4. CHECK TRUNK LID OPENER ACTUATOR CIRCUIT

1. Disconnect BCM connector.
2. Check continuity between BCM connector M19 (A) terminal 53 and trunk lid opener actuator connector B59 (B) terminal 1.

A		B		Continuity
BCM connector	Terminal	Trunk lid opener actuator connector	Terminal	
M19	53	B59	1	Yes

3. Check continuity between BCM connector M19 (A) terminal 53 and ground.

BCM connector	Terminal	Ground	Continuity
M19	53		No

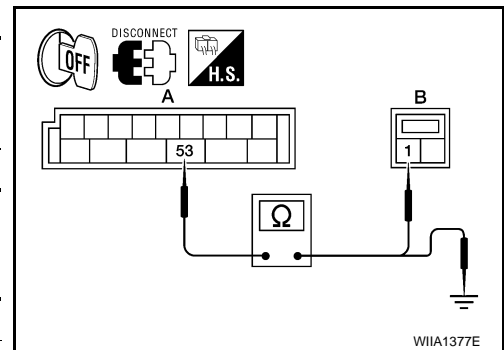

#### OK or NG

- OK >> GO TO 5.
- NG >> Repair or replace harness between BCM and trunk lid opener actuator.

### 5. CHECK BCM OUTPUT SIGNAL

1. Reconnect BCM connector.
2. Check voltage between BCM connector M19 terminal 53 and ground.

Terminals			Condition	Voltage (V) (Approx.)
BCM connector	(+)	(-)		
	M19	53	Ground	Keyfob trunk release button
Released				0

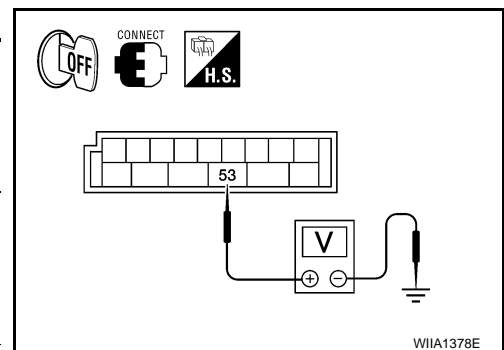

#### OK or NG

- OK >> Check the condition of harness and connector.
- NG >> Replace BCM. Refer to [BCS-17](#), "[Removal and Installation of BCM](#)".

# FUEL FILLER LID OPENER

< SERVICE INFORMATION >

## FUEL FILLER LID OPENER

### Removal

INFOID:000000004407787

1. Remove trunk side finisher (RH). Refer to [EI-43](#).
2. Remove fuel filler lock.
3. Remove rear seat cushion assembly. Refer to [SE-19](#).

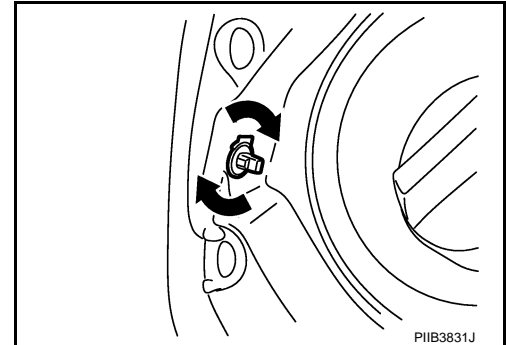

4. Remove front kicking plate and rear kicking plate. Refer to [EI-33](#).
5. Remove the trunk and fuel lid opener control cover.
6. Remove the bolts (a), disconnect the cables (1), and remove the trunk and fuel lid opener control (2).

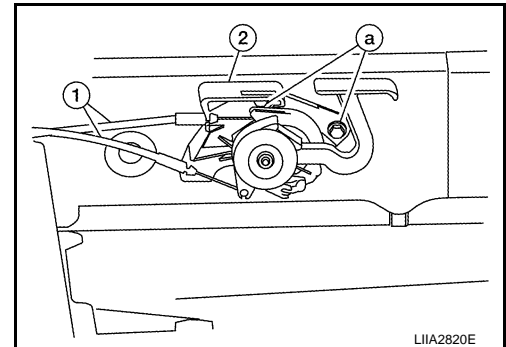

7. Remove fuel filler lid opener cable and clips from the vehicle.

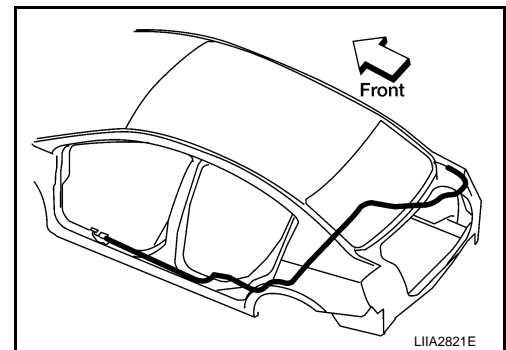

### Installation

INFOID:000000004407788

Installation is in the reverse order of removal.

# VEHICLE SECURITY (THEFT WARNING) SYSTEM

< SERVICE INFORMATION >

## VEHICLE SECURITY (THEFT WARNING) SYSTEM

### Component Parts and Harness Connector Location

INFOID:000000004407789

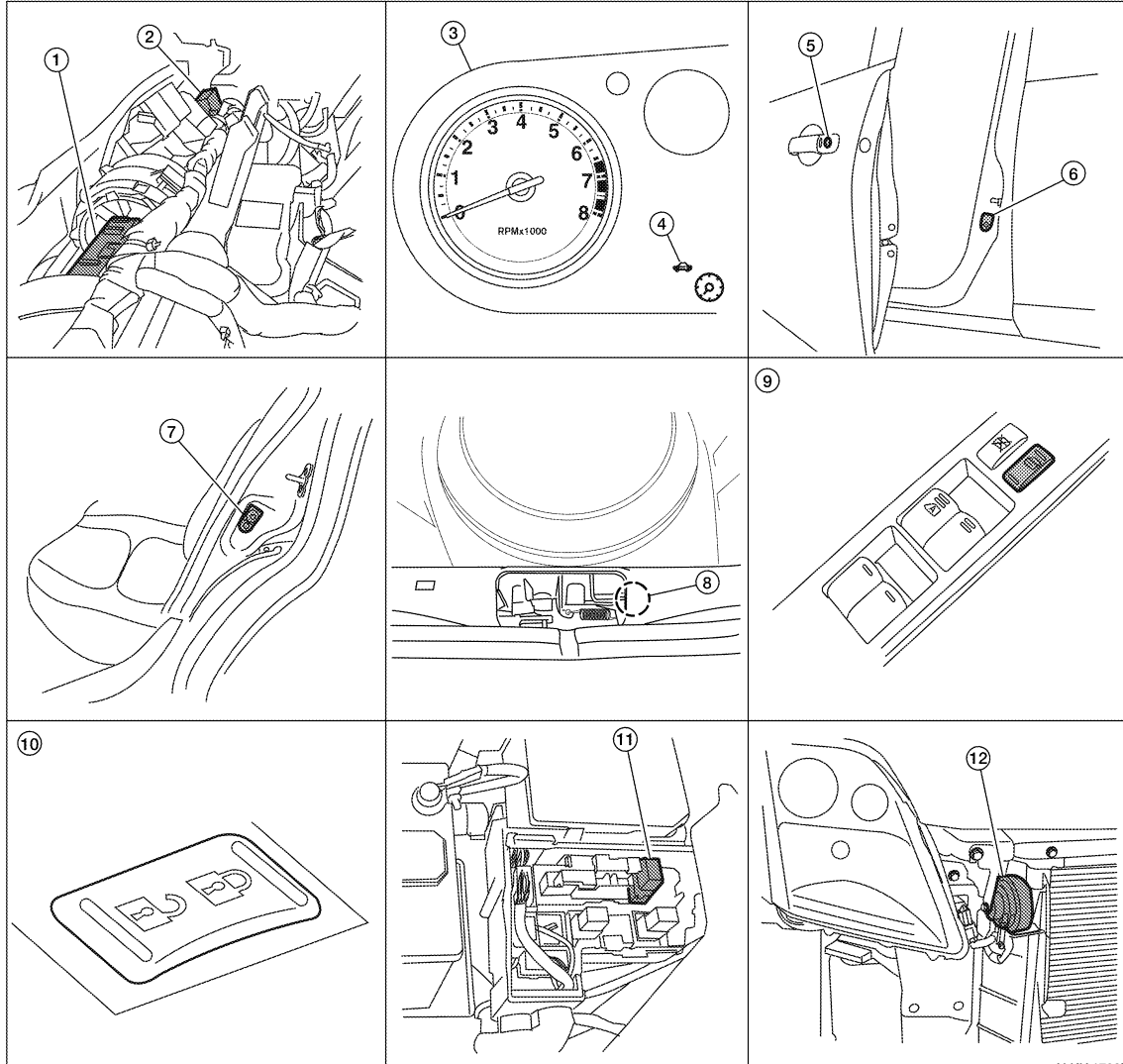

- |  |   |  |
|--|---|--|
| 1. BCM M18, M19, M20<br>(view with instrument panel removed) | 2. Intelligent Key unit M42<br>(with Intelligent Key) | 3. Combination meter M24   |
| 4. Security indicator lamp                                   | 5. Front door key cylinder switch LH D9               | 6. Front door switch LH B21, RH B28  |
| 7. Rear door switch LH B26, RH B41                           | 8. Trunk room lamp switch B57                         | 9. Main power window and door lock/unlock switch D5, D11 (with power windows)<br>Power window and door lock/unlock switch RH D104 (with power windows) |
| 10. Door lock/unlock switch LH D6<br>(without power windows) | 11. Horn relay H-1                                    | 12. Horn E57, E58  |

### System Description

INFOID:000000004407790

#### DESCRIPTION

#### Operation Flow

# VEHICLE SECURITY (THEFT WARNING) SYSTEM

## < SERVICE INFORMATION >

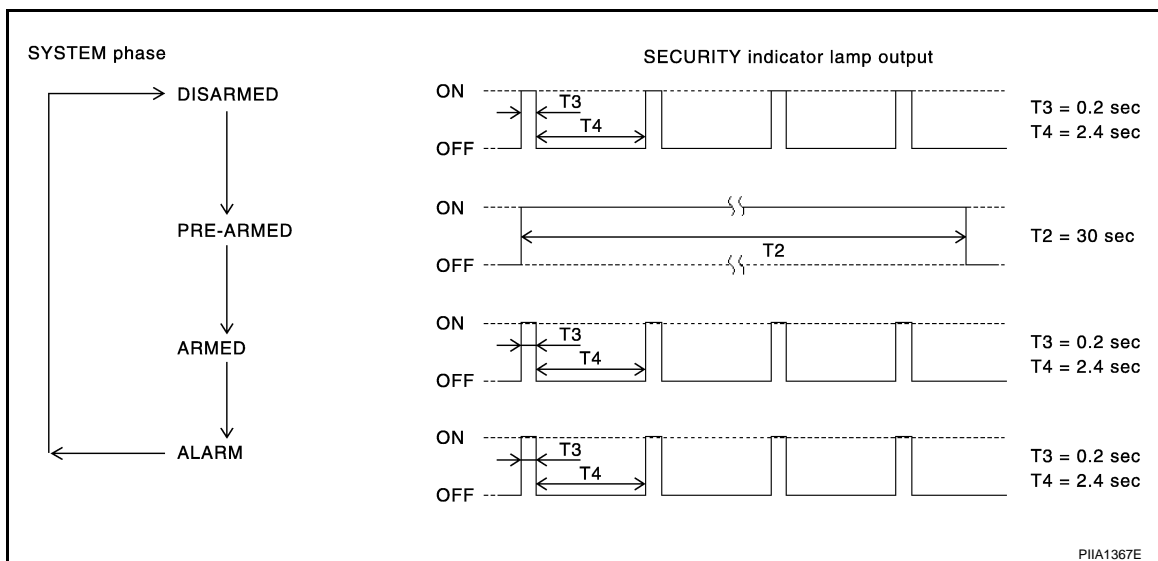

### Setting the vehicle security system

#### Initial condition

- Ignition switch is in OFF position.

#### Disarmed phase

- When the vehicle is being driven or when any door is open, the vehicle security system is set in the disarmed phase on the assumption that the owner is inside or near the vehicle.

#### Pre-armed phase and armed phase

- The vehicle security system turns into the "pre-armed" phase (security lamp illuminates) when the BCM receives LOCK signal from front door key cylinder switch, keyfob or Intelligent Key after all doors are closed.
  - All doors are closed after front doors are locked by key or door lock and unlock switch.
- The security indicator lamp illuminates for 30 seconds. then, the system automatically shifts into the "armed" phase.

#### Canceling the set vehicle security system

The armed phase is canceled when the driver unlocks the doors with the key, keyfob or Intelligent Key.

#### Activating the alarm operation of the vehicle security system

Make sure the system is in the armed phase.

When one of the following operations is performed, the system sounds the horn and flashes the headlamps for about 50 seconds.

1. Any door is opened before unlocking door with key, keyfob or Intelligent Key.
2. Door is unlocked without using key, keyfob or Intelligent Key.

### POWER SUPPLY AND GROUND

Power is supplied at all times

- through 10A fuse [No.19, located in the fuse block (J/B)]
- to combination meter terminal 1 (security indicator lamp)
- through 50A fusible link (letter j, located in the fuse and fusible link box)
- to BCM terminal 70
- through 10A fuse [No. 21, located in the fuse block (J/B)]
- to BCM terminal 57
- through 10A fuse (No. 25, located in the fuse and fusible link box)
- to horn relay terminal 2
- through 15A fuse (No. 52, located in the IPDM E/R)
- to IPDM E/R internal CPU
- through 20A fuse (No. 53, located in the IPDM E/R)
- to IPDM E/R internal CPU.

With the ignition switch in the ACC or ON position, power is supplied

- through 10A fuse [No. 6, located in the fuse block (J/B)]

# VEHICLE SECURITY (THEFT WARNING) SYSTEM

## < SERVICE INFORMATION >

---

- to BCM terminal 11.

With the ignition switch in the ON or START position, power is supplied

- through 10A fuse [No. 12, located in the fuse block (J/B)]
- to BCM terminal 38.

Ground is supplied

- to BCM terminal 67
- through body grounds M57 and M61.

### INITIAL CONDITION TO ACTIVATE THE SYSTEM

The operation of the vehicle security system is controlled by the doors and trunk.

To activate the vehicle security system, BCM must receive signals indicating the ignition switch is OFF, doors and trunk are closed and locked.

When a door or trunk is open, BCM terminal 12, 13, 42, 47 or 48 receives a ground signal from each switch.

When front door LH is unlocked, BCM terminal 46 receives a signal from terminal 11 (without Automatic Close Power Window) or terminal 2 (with Automatic Close Power Window) of main power window and door lock/unlock switch.

When front door RH is unlocked, BCM terminal 46 receives a signal from terminal 2 of power window and door lock/unlock switch RH.

### VEHICLE SECURITY SYSTEM ALARM OPERATION

The vehicle security system is triggered by

- opening a door
- opening the trunk
- unlocking door or trunk without using the key, keyfob or Intelligent Key.

The vehicle security system will be triggered once the system is in armed phase,

- when BCM receives a ground signal at terminals 12, 13, 47, 48 (front or rear door switch), or terminal 42 (trunk switch).

When the vehicle security system is triggered, ground is supplied intermittently

- from IPDM E/R terminal 13
- to horn relay terminal 1.

The headlamps flash and the horn sounds intermittently.

The alarm automatically turns off after 50 seconds, but will reactivate if the vehicle is tampered with again.

### VEHICLE SECURITY SYSTEM DEACTIVATION

To deactivate the vehicle security system, a door must be unlocked with the key, keyfob or Intelligent Key.

When the key is used to unlock the driver door, BCM terminal 7 receives signal

- from terminal 5 of the front door key cylinder switch LH.

When the BCM receives this signal or unlock signal from keyfob or Intelligent Key or front door key cylinder switch LH, the vehicle security system is deactivated. (Disarmed phase)

### PANIC ALARM OPERATION

Intelligent Key and remote keyless entry system may or may not operate vehicle security system (horn and headlamps) as required.

When the remote keyless entry system is triggered, ground is supplied intermittently

- from IPDM E/R terminal 13
- to horn relay terminal 1.

The headlamp flashes and the horn sounds intermittently.

The alarm automatically turns off after 25 seconds or when BCM receives any signal from keyfob or Intelligent Key.

### CAN Communication System Description

INFOID:000000004407791

Refer to [LAN-6, "System Description"](#).

A  
B  
C  
D  
E  
F  
G  
H  
BL  
J  
K  
L  
M  
N  
O  
P

# VEHICLE SECURITY (THEFT WARNING) SYSTEM

< SERVICE INFORMATION >

## Schematic

INFOID:000000004407792

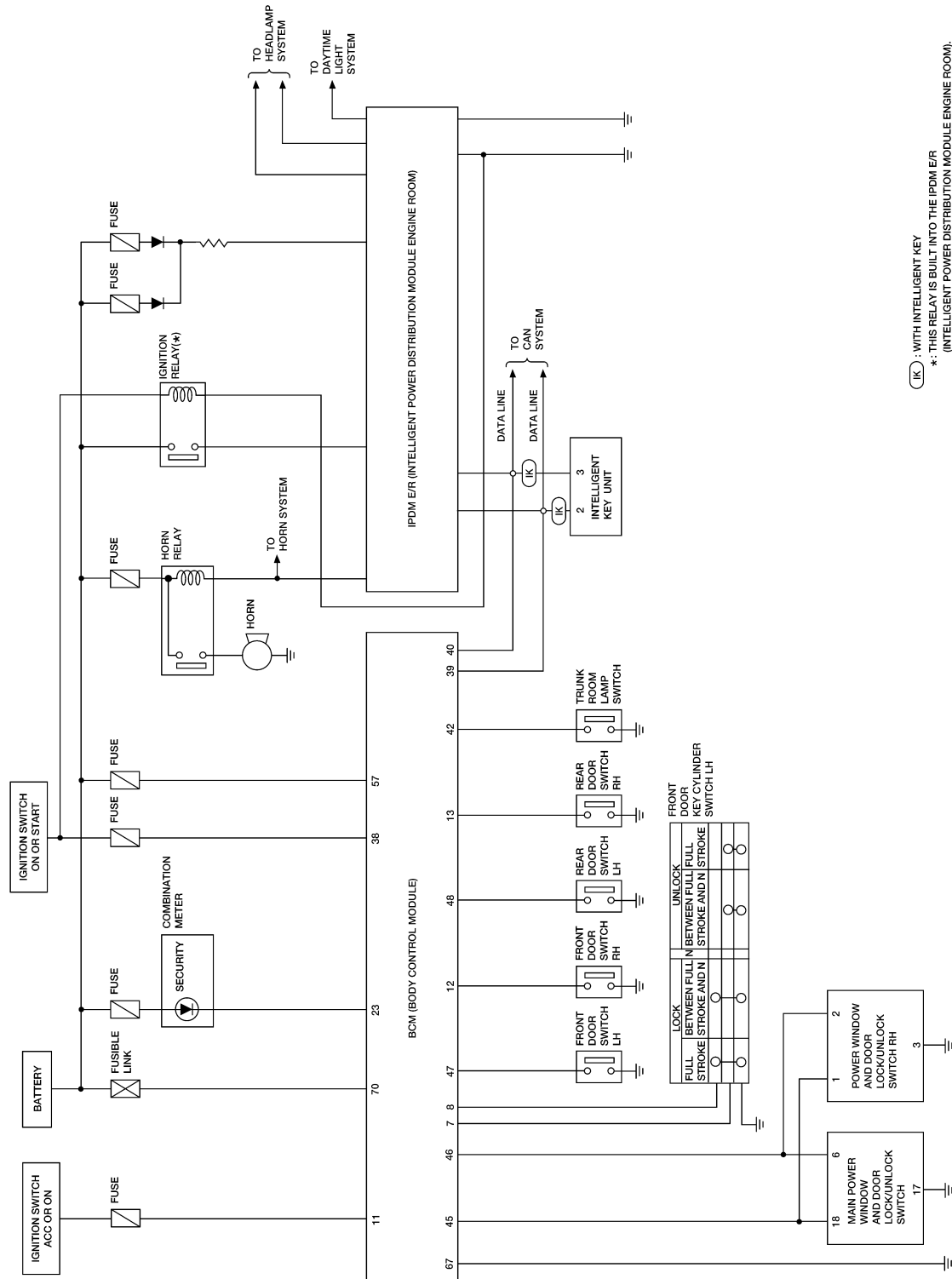

(IK) : WITH INTELLIGENT KEY  
 \*: THIS RELAY IS BUILT INTO THE IPDM E/R  
 (INTELLIGENT POWER DISTRIBUTION MODULE ENGINE ROOM).

ABKWA0332GE



# VEHICLE SECURITY (THEFT WARNING) SYSTEM

< SERVICE INFORMATION >

## Wiring Diagram - VEHSEC -

INFOID:000000004407793

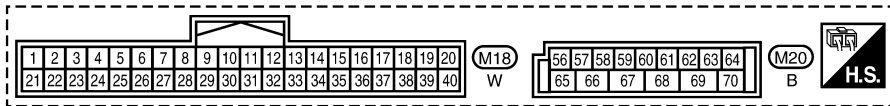
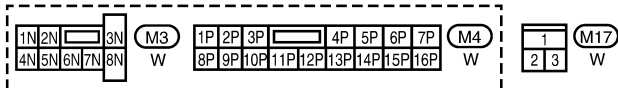
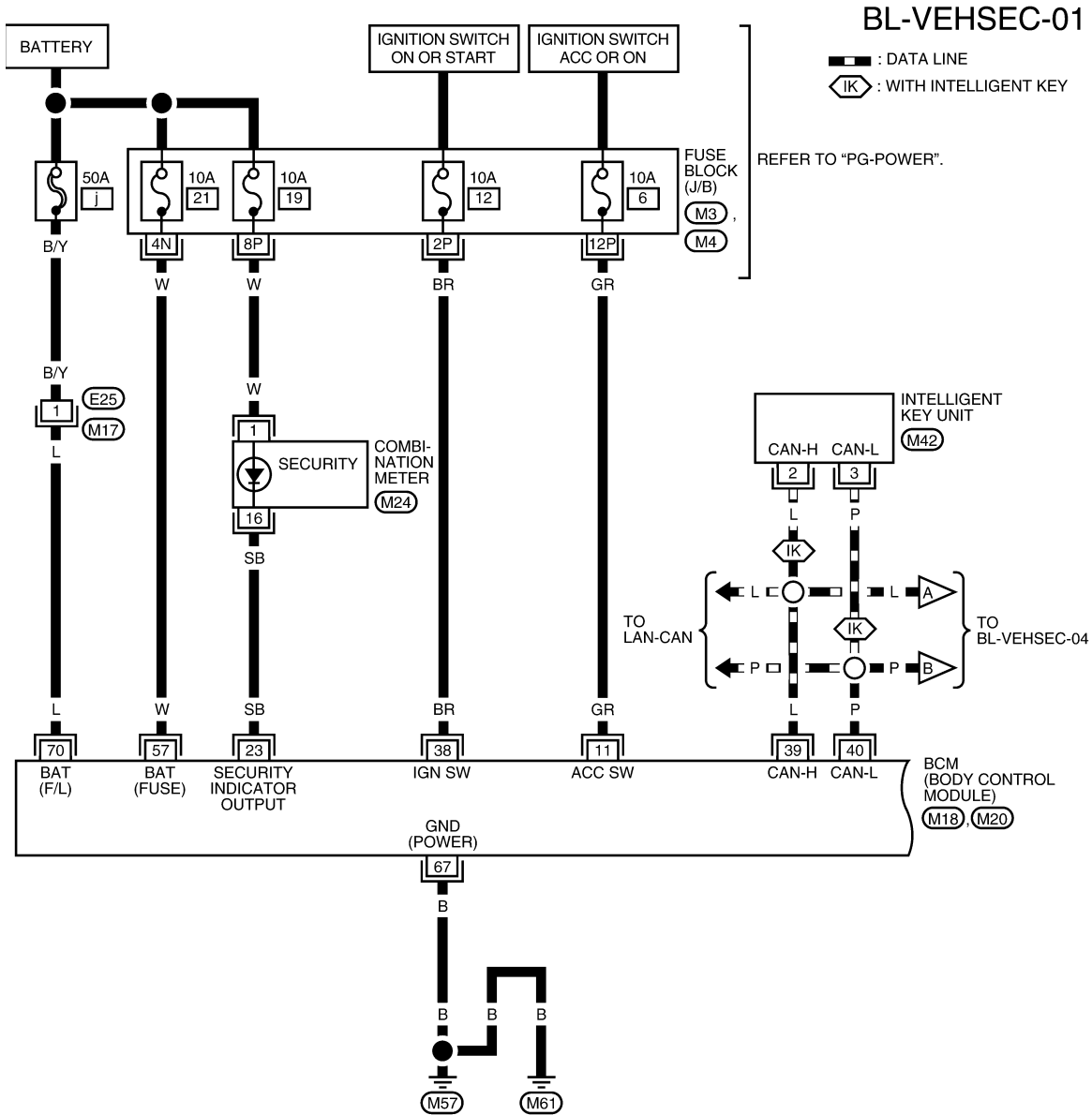

WIWA2191E

# VEHICLE SECURITY (THEFT WARNING) SYSTEM

< SERVICE INFORMATION >

BL-VEHSEC-02

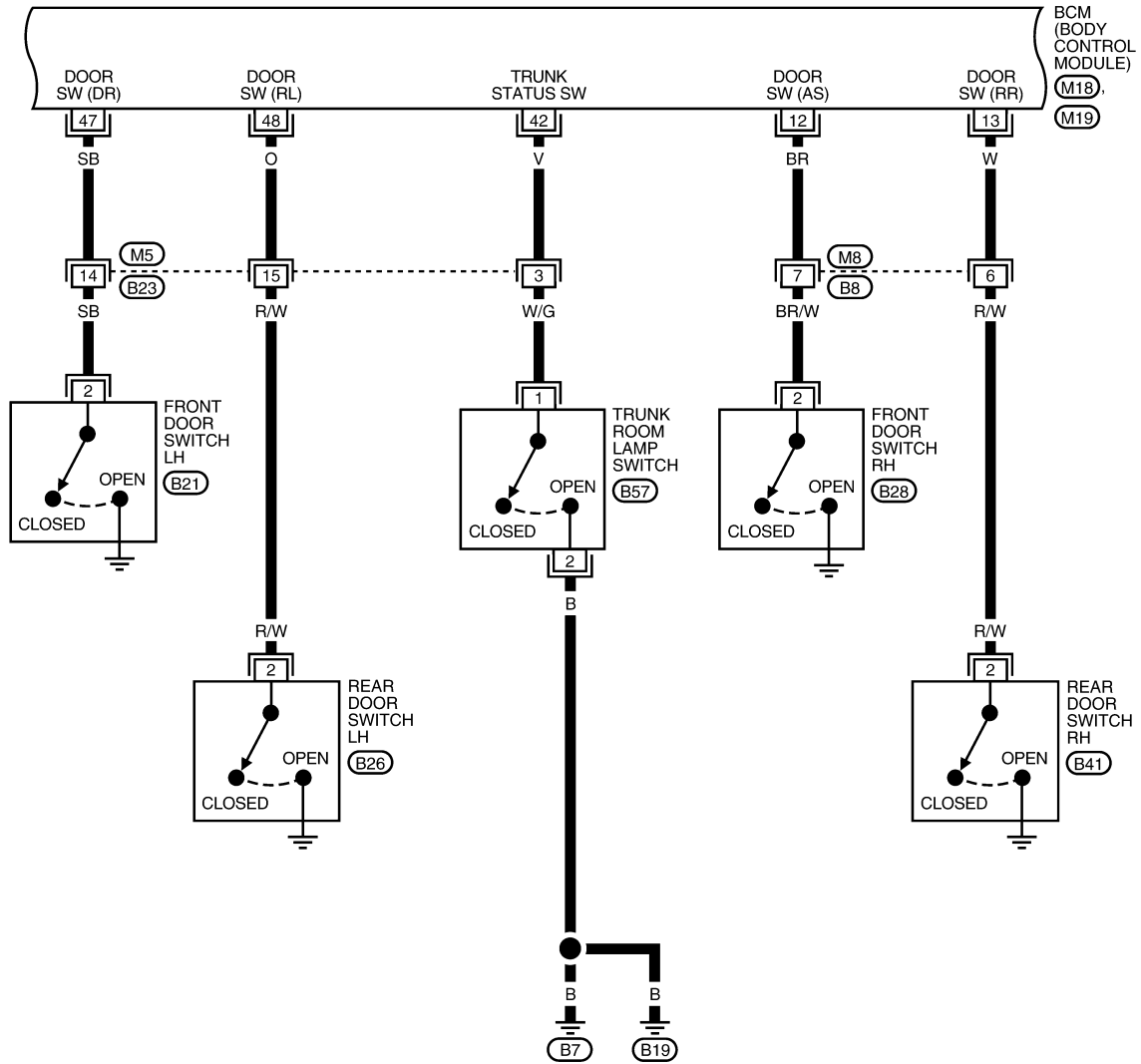

1	2	3	4	5	6	7	M5	M8		
8	9	10	11	12	13	14	15	16	GR	W

1	2	3	4	5	6	7	8	9	10	11	12	13	14	15	16	17	18	19	20	M18	41	42	43	44	45	46	47	48	49	M19	H.S.
21	22	23	24	25	26	27	28	29	30	31	32	33	34	35	36	37	38	39	40	W	50	51	52	53	54	55	W				

1	2	3	B21	B26	B28	B41	B57
1	2	3	W	W	W	W	2 1 W

WIWA2192E

# VEHICLE SECURITY (THEFT WARNING) SYSTEM

< SERVICE INFORMATION >

BL-VEHSEC-03

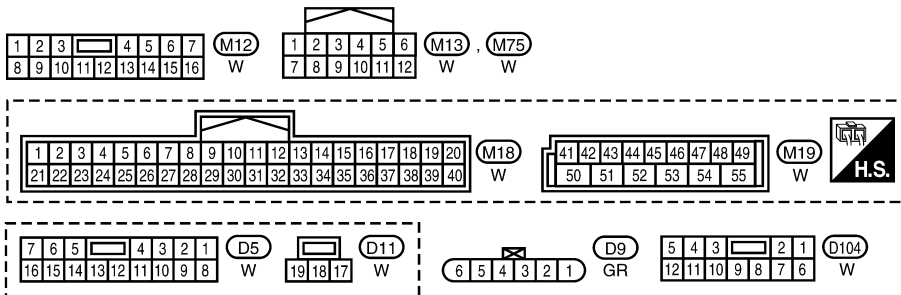
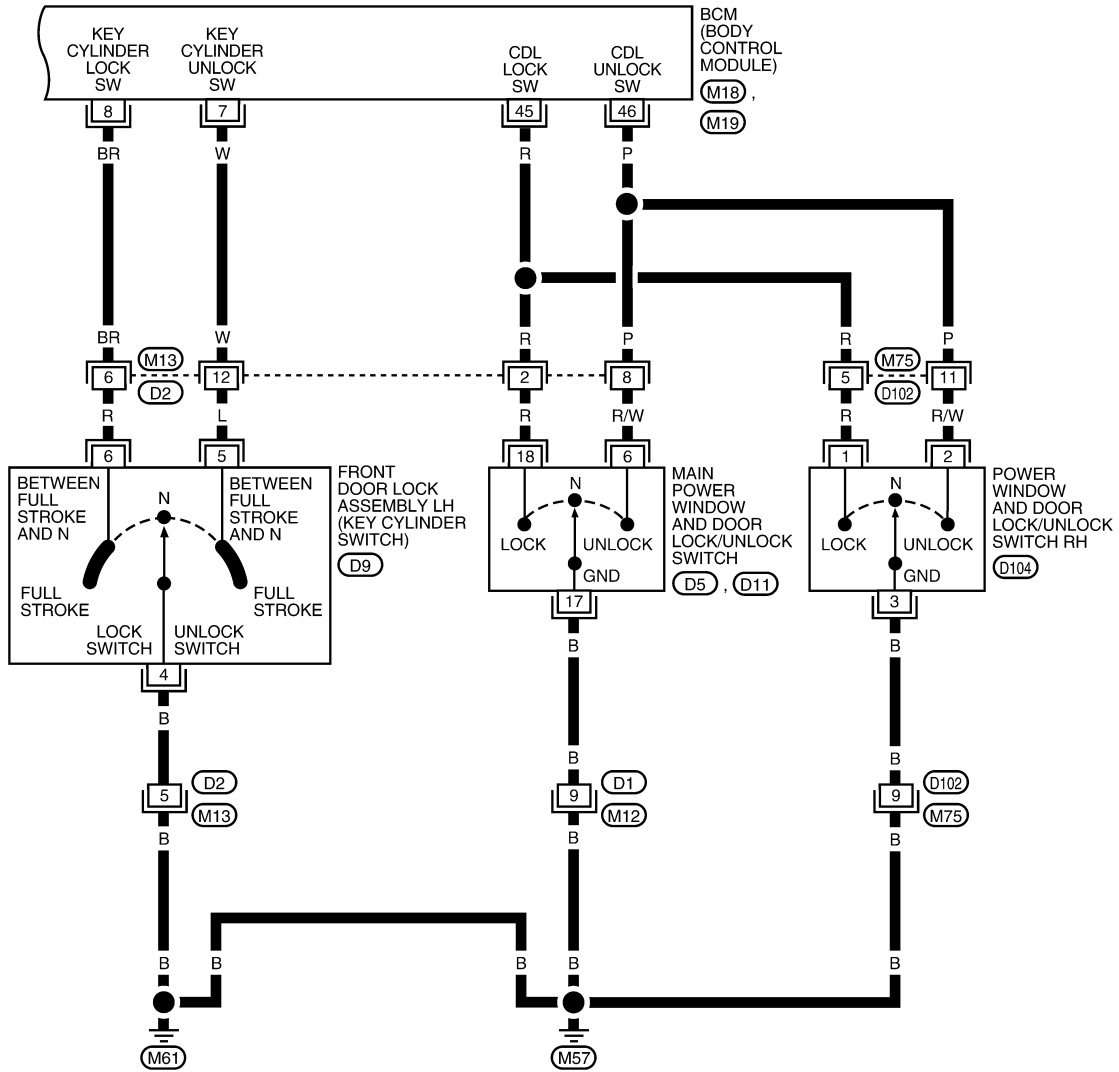

ABKWA0333GE

# VEHICLE SECURITY (THEFT WARNING) SYSTEM

< SERVICE INFORMATION >

BL-VEHSEC-04

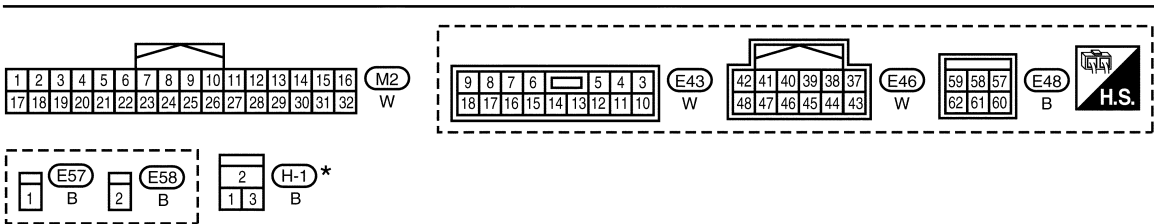
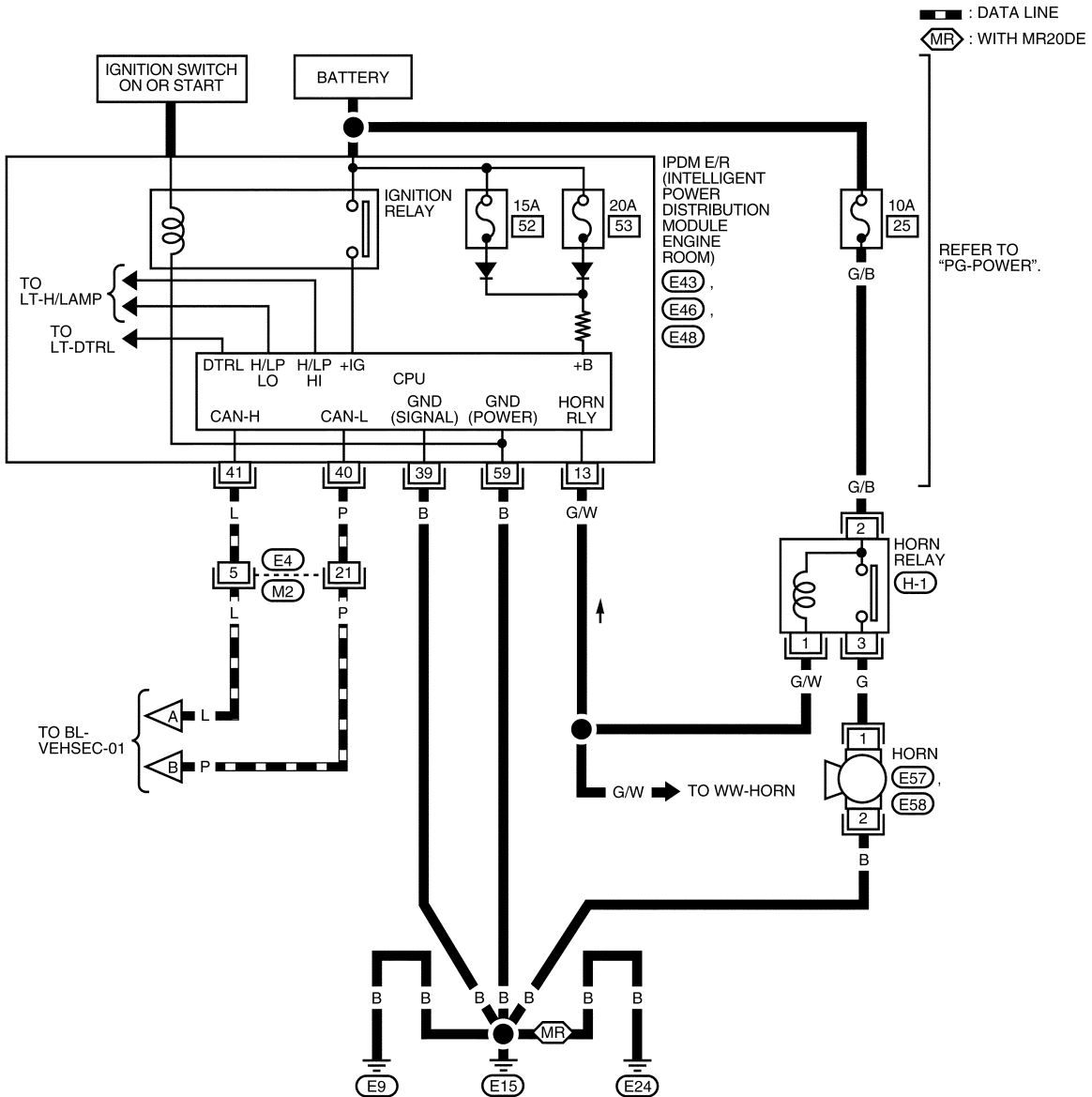

\*: THIS CONNECTOR IS NOT SHOWN IN "HARNESS LAYOUT" OF PG SECTION.

WIWA2325E

## Terminal and Reference Value for BCM

Refer to [BCS-11, "Terminal and Reference Value for BCM"](#).

INFOID:000000004407794

## Terminal and Reference Value for Intelligent Key Unit

Refer to [BL-92, "Terminal and Reference Value for Intelligent Key Unit"](#).

INFOID:000000004407795

# VEHICLE SECURITY (THEFT WARNING) SYSTEM

< SERVICE INFORMATION >

## CONSULT-III Function (BCM)

INFOID:000000004407796

CONSULT-III can display each diagnostic item using the diagnostic test modes shown following.

BCM diagnostic test item	Diagnostic mode	Description
Inspection by part	WORK SUPPORT	Supports inspections and adjustments. Commands are transmitted to the BCM for setting the status suitable for required operation, input/output signals are received from the BCM and received date is displayed.
	DATA MONITOR	Displays BCM input/output data in real time.
	ACTIVE TEST	Operation of electrical loads can be checked by sending drive signal to them.
	SELF-DIAG RESULTS	Displays BCM self-diagnosis results.
	CAN DIAG SUPPORT MNTR	The result of transmit/receive diagnosis of CAN communication can be read.
	ECU PART NUMBER	BCM part number can be read.
	CONFIGURATION	Performs BCM configuration read/write functions.

## CONSULT-III APPLICATION ITEM

### Work Support

Test Item	Description
SECURITY ALARM SET	This mode can confirm and change security alarm ON-OFF setting.
THEFT ALM TRG	The switch which triggered vehicle security alarm is recorded. This mode is able to confirm and erase the record of vehicle security alarm. The trigger data can be erased by touching "CLEAR" on CONSULT-III screen.

### Data Monitor

Monitored Item	Description
IGN ON SW	Indicates [ON/OFF] condition of ignition switch.
ACC ON SW	Indicates [ON/OFF] condition of ignition switch in ACC position.
I-KEY LOCK	Indicates [ON/OFF] condition of lock signal from keyfob.
I-KEY UNLOCK	Indicates [ON/OFF] condition of unlock signal from keyfob.
I-KEY TRUNK	Indicates [ON/OFF] condition of trunk open signal from keyfob.
TRNK OPNR SW	Indicates [ON/OFF] condition of trunk opener switch.
TRUNK CYL SW	Indicates [ON/OFF] condition of trunk key cylinder switch.
TRNK OPN MNTR	Indicates [ON/OFF] condition of trunk lid status.
DOOR SW-DR	Indicates [ON/OFF] condition of front door switch LH.
DOOR SW-AS	Indicates [ON/OFF] condition of front door switch RH.
DOOR SW-RR	Indicates [ON/OFF] condition of rear door switch RH.
DOOR SW-RL	Indicates [ON/OFF] condition of rear door switch LH.
BACK DOOR SW	Indicates [ON/OFF] condition of back door switch.
KEY CYL LK SW	Indicates [ON/OFF] condition of lock signal from key cylinder switch.
KEY CYL UN SW	Indicates [ON/OFF] condition of unlock signal from key cylinder switch.
CDL LOCK SW	Indicates [ON/OFF] condition of lock signal from door lock/unlock switch LH and RH.
CDL UNLOCK SW	Indicates [ON/OFF] condition of unlock signal from door lock/unlock switch LH and RH.

### Active Test

# VEHICLE SECURITY (THEFT WARNING) SYSTEM

## < SERVICE INFORMATION >

Test Item	Description
THEFT IND	This test is able to check security indicator lamp operation. The lamp will be turned on when "ON" on CONSULT-III screen is touched.
VEHICLE SECURITY HORN	This test is able to check vehicle security horn operation. The horns will be activated for 0.5 seconds after "ON" on CONSULT-III screen is touched.
HEADLAMP (HI)	This test is able to check vehicle security lamp operation. The headlamps will be activated for 0.5 seconds after "ON" on CONSULT-III screen is touched.

## Trouble Diagnosis

INFOID:000000004407797

### WORK FLOW

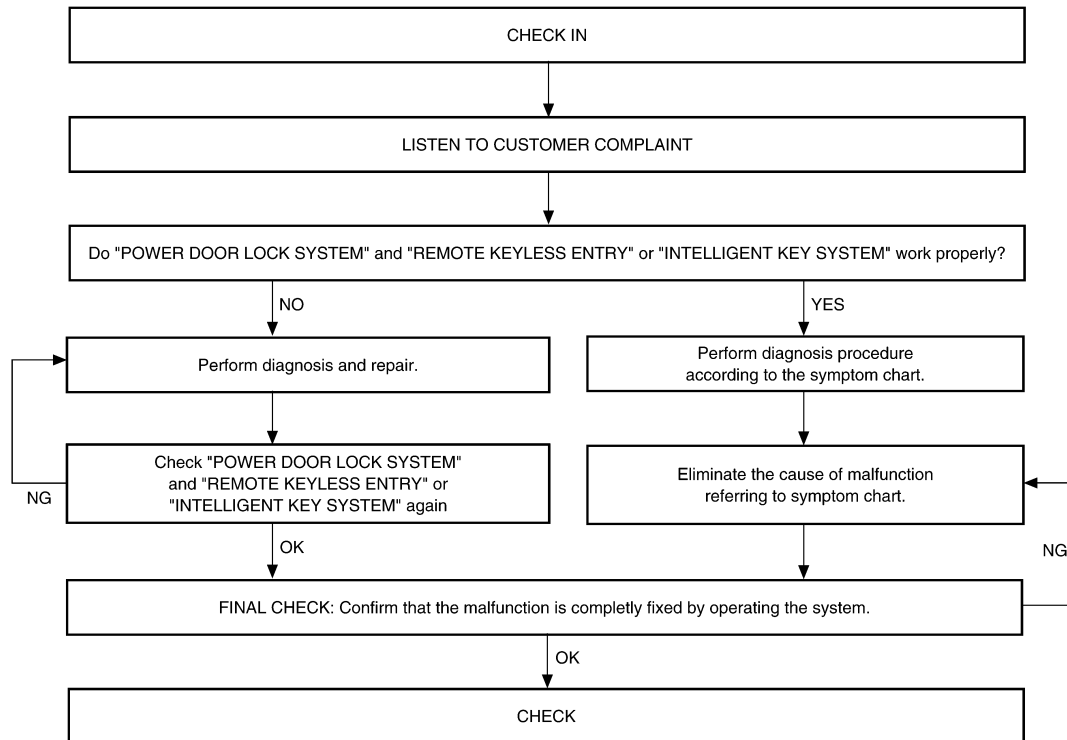

LIA2635E

- For "POWER DOOR LOCK SYSTEM" diagnosis, refer to [BL-20](#).
- For "INTELLIGENT KEY SYSTEM" diagnosis, refer to [BL-71](#).
- For "REMOTE KEYLESS ENTRY SYSTEM" diagnosis, refer to [BL-50](#).

## Preliminary Check

INFOID:000000004407798

### 1. CHECK BCM CONFIGURATION

Confirm BCM configuration for "THEFT ALARM" is set to "WITH". Refer to [BCS-17. "Configuration"](#).

#### OK or NG

- OK >> Proceed with the preliminary check to verify system operation.
- NG >> Change BCM configuration for "THEFT ALARM" to "WITH". Refer to [BCS-17. "Configuration"](#).

# VEHICLE SECURITY (THEFT WARNING) SYSTEM

## < SERVICE INFORMATION >

The system operation is canceled by turning ignition switch to ACC at any step between START and ARMED in the following flow chart.

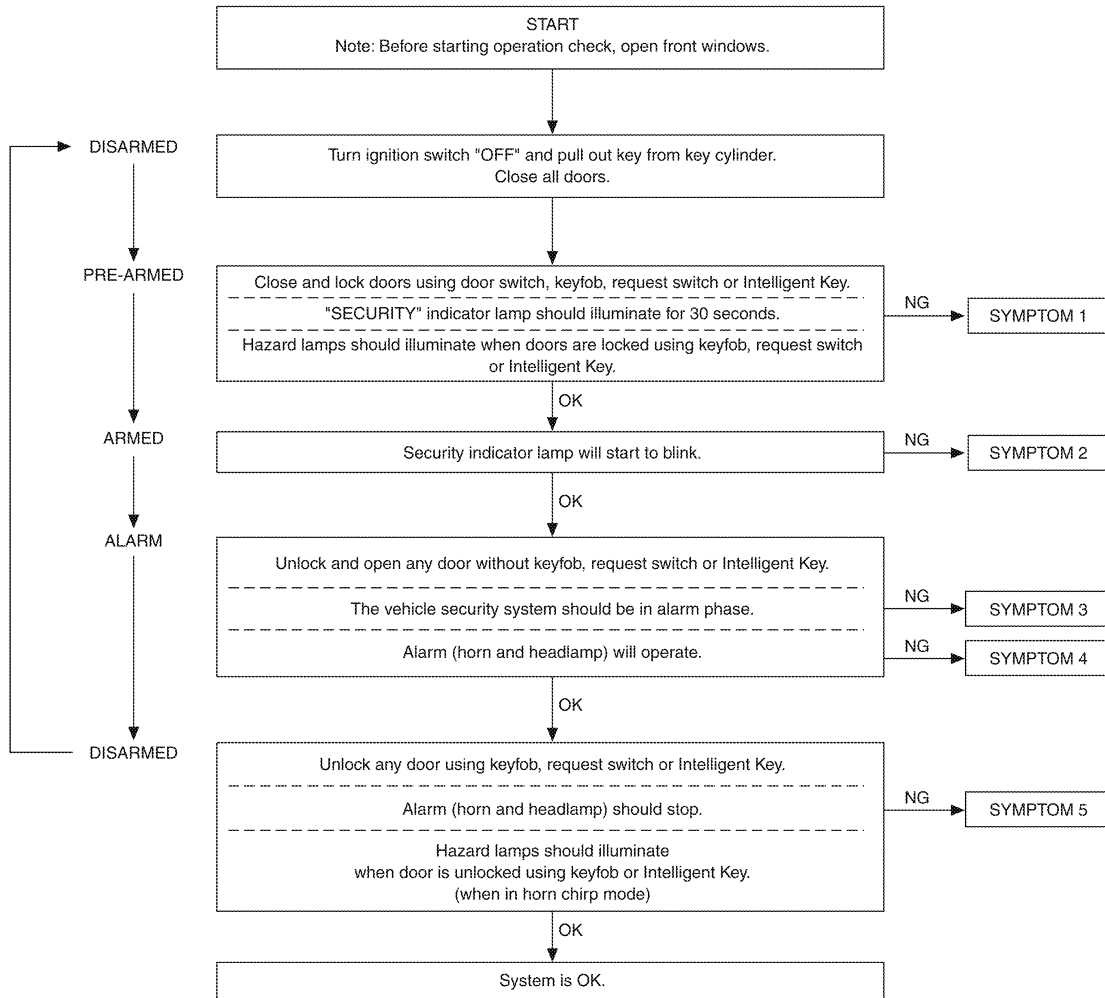

ALKIA1784GB

After performing preliminary check, go to symptom chart. Refer to [BL-164, "Symptom Chart"](#).

# VEHICLE SECURITY (THEFT WARNING) SYSTEM

< SERVICE INFORMATION >

## Symptom Chart

INFOID:000000004407799

	SYMPTOM	PROCEDURE	Diagnostic procedure
1	Vehicle security system cannot be set by ....	All items	Diagnostic Procedure 1 (Door switch check) Refer to <a href="#">BL-165, "Diagnosis Procedure 1"</a> .
			Diagnostic Procedure 7 (Trunk room lamp switch check) Refer to <a href="#">BL-168, "Diagnosis Procedure 7"</a> .
			If the above systems are "OK", replace BCM. Refer to <a href="#">BCS-17, "Removal and Installation of BCM"</a> .
		Lock/unlock switch	Diagnostic Procedure 6 (Door lock/unlock switch check) Refer to <a href="#">BL-167, "Diagnosis Procedure 6"</a> .
			If the above systems are "OK", check main power window and door lock/unlock switch. Refer to <a href="#">GW-15</a> .
		Door outside key (driver)	Diagnostic Procedure 3 (Door key cylinder switch check) Refer to <a href="#">BL-167, "Diagnosis Procedure 3"</a> .
If the above systems are "OK", check main power window and door lock/unlock switch. Refer to <a href="#">GW-15</a> .			
Keyfob	Check remote keyless entry function. Refer to <a href="#">BL-99, "Trouble Diagnosis Symptom Chart"</a> .		
	If the above systems are "OK", replace BCM. Refer to <a href="#">BCS-17, "Removal and Installation of BCM"</a> .		
2	Security indicator does not turn "ON".	Security indicator lamp	Diagnostic Procedure 2 (Security indicator lamp check) Refer to <a href="#">BL-166, "Diagnosis Procedure 2"</a> .
			If the above systems are "OK", replace BCM. Refer to <a href="#">BCS-17, "Removal and Installation of BCM"</a> .
3	*1 Vehicle security system does not alarm when ....	Any door or trunk is opened.	Diagnostic Procedure 1 (Door switch check) Refer to <a href="#">BL-165, "Diagnosis Procedure 1"</a> .
			Diagnostic Procedure 7 (Trunk room lamp switch check) Refer to <a href="#">BL-168, "Diagnosis Procedure 7"</a> .
			If the above systems are "OK", replace BCM. Refer to <a href="#">BCS-17, "Removal and Installation of BCM"</a> .
4	Vehicle security alarm does not activate.	Horn alarm	Diagnostic Procedure 4 (Vehicle security horn alarm check). Refer to <a href="#">BL-167, "Diagnosis Procedure 4"</a> .
			If the above systems are "OK", check horn system. Refer to <a href="#">WW-27</a> .
		Head lamp alarm	Diagnostic Procedure 5 (Head lamp alarm check). Refer to <a href="#">BL-167, "Diagnosis Procedure 5"</a> .
			If the above systems are "OK", replace BCM. Refer to <a href="#">BCS-17, "Removal and Installation of BCM"</a> .
5	Vehicle security system cannot be canceled by ....	Door outside key (driver)	Diagnostic Procedure 3 (Door key cylinder switch check). Refer to <a href="#">BL-167, "Diagnosis Procedure 3"</a> .
			If the above systems are "OK", check main power window and door lock/unlock switch. Refer to <a href="#">GW-15</a> .
		Intelligent key	Check Intelligent Key entry function. Refer to <a href="#">BL-72, "System Description"</a> .
			If the above systems are "OK", replace BCM. Refer to <a href="#">BCS-17, "Removal and Installation of BCM"</a> .
Keyfob	Check remote keyless entry function. Refer to <a href="#">BL-99, "Trouble Diagnosis Symptom Chart"</a> .		
	If the above systems are "OK", replace BCM. Refer to <a href="#">BCS-17, "Removal and Installation of BCM"</a> .		

\*1 : Make sure the system is in the armed phase.



# VEHICLE SECURITY (THEFT WARNING) SYSTEM

< SERVICE INFORMATION >

## Diagnosis Procedure 1

INFOID:000000004407800

### DOOR SWITCH CHECK

#### 1. CHECK DOOR SWITCHES INPUT SIGNAL

With CONSULT-III

Check door switches ("DOOR SW-DR", "DOOR SW-AS", "DOOR SW-RL", "DOOR SW-RR") in DATA MONITOR mode with CONSULT-III. Refer to [BL-36, "CONSULT-III Function \(BCM\)"](#).

- When any doors are open:

**DOOR SW-DR : ON**  
**DOOR SW-AS : ON**  
**DOOR SW-RL : ON**  
**DOOR SW-RR : ON**

- When any doors are closed:

**DOOR SW-DR : OFF**  
**DOOR SW-AS : OFF**  
**DOOR SW-RL : OFF**  
**DOOR SW-RR : OFF**

Without CONSULT-III

Check voltage between BCM connector M18 or M19 terminals 12, 13, 47, 48 and ground.

Connector	Item	Terminals		Condition	Voltage (V) (Approx.)
		(+)	(-)		
M19	Front door switch LH	47	Ground	Open ↓ Closed	0 ↓ Battery voltage
	Rear door switch LH	48			
M18	Front door switch RH	12			
	Rear door switch RH	13			

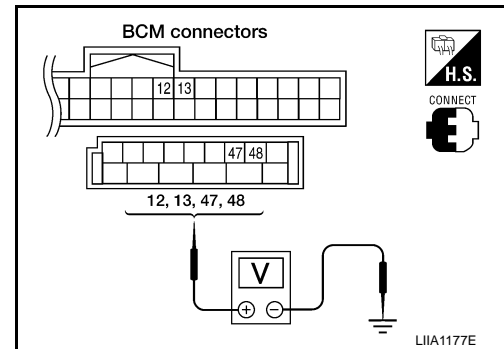

OK or NG

- OK >> Door switch circuit is OK.
- NG >> GO TO 2.

#### 2. CHECK DOOR SWITCH CIRCUIT

- Turn ignition switch OFF.
- Disconnect door switch and BCM.
- Check continuity between door switch connector B21 (Front LH), B28 (Front RH), B26 (Rear LH), B41 (Rear RH) terminal 2 and BCM connector M18, M19 terminals 12, 13, 47 and 48.

**2 - 47 : Continuity should exist.**  
**2 - 12 : Continuity should exist.**  
**2 - 48 : Continuity should exist.**  
**2 - 13 : Continuity should exist.**

- Check continuity between door switch connector B21 (Front LH), B28 (Front RH), B26 (Rear LH), B41 (Rear RH) terminal 2 and ground.

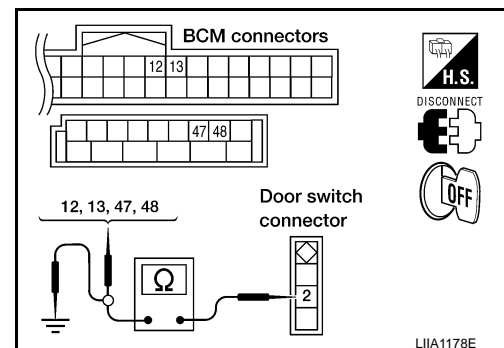

# VEHICLE SECURITY (THEFT WARNING) SYSTEM

< SERVICE INFORMATION >

**2 - Ground : Continuity should not exist.**

OK or NG

- OK >> GO TO 3.
- NG >> Repair or replace harness.

## 3. CHECK DOOR SWITCHES

Check continuity between door switch terminals.

Door switch (front or rear)	Terminals		Condition	Continuity
		2 - Ground		Pressed
			Released	Yes

OK or NG

- OK >> GO TO 4.
- NG >> Replace door switch.

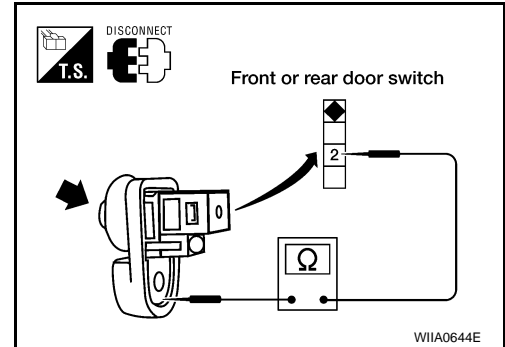

## 4. CHECK BCM OUTPUT VOLTAGE

1. Reconnect BCM connectors.
2. Check voltage between BCM connector M18, M19 terminals 12, 13, 47, 48 and ground.

- 12 - Ground : Battery voltage**
- 13 - Ground : Battery voltage**
- 47 - Ground : Battery voltage**
- 48 - Ground : Battery voltage**

OK or NG

- OK >> Door switch circuit is OK.
- NG >> Replace BCM. Refer to [BCS-17, "Removal and Installation of BCM"](#).

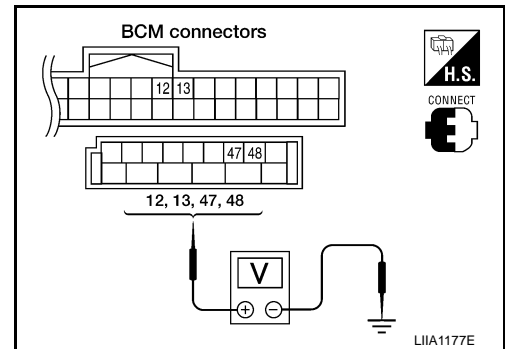

## Diagnosis Procedure 2

INFOID:000000004407801

### SECURITY INDICATOR LAMP CHECK

#### 1. SECURITY INDICATOR LAMP ACTIVE TEST

**With CONSULT-III**

Check "THEFT IND" in "ACTIVE TEST" mode with CONSULT-III.

**Without CONSULT-III**

1. Disconnect BCM.
2. Check voltage between BCM harness connector M18 terminal 23 and ground.

Connector	Terminals		Condition	Voltage (V) (Approx.)
	(+)	(-)		
M18	23	Ground	ON	0
			OFF	Battery voltage

OK or NG

- OK >> Security indicator lamp is OK.
- NG >> GO TO 2.

#### 2. SECURITY INDICATOR LAMP CHECK

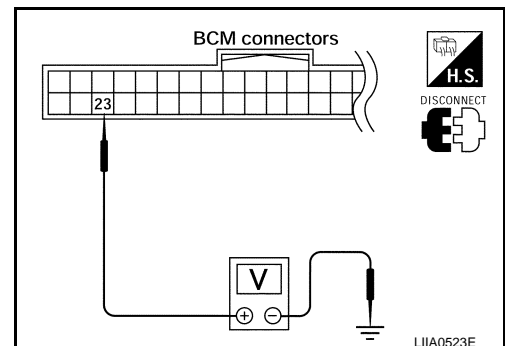

# VEHICLE SECURITY (THEFT WARNING) SYSTEM

## < SERVICE INFORMATION >

Check security indicator lamp condition.

### OK or NG

- OK >> GO TO 3.
- NG >> Replace security indicator lamp.

## 3.CHECK HARNESS CONTINUITY

1. Turn ignition switch OFF.
2. Disconnect BCM and combination meter.
3. Check continuity between BCM connector M18 (A) terminal 23 and combination meter connector M24 (B) terminal 16.

**23 - 16 : Continuity should exist.**

4. Check continuity between BCM connector M18 (A) terminal 23 and ground.

**23 - Ground : Continuity should not exist.**

### OK or NG

- OK >> Check the following:
  - 10A fuse [No. 19, located in fuse block (J/B)]
  - Harness for open or short between combination meter and fuse
- NG >> Repair or replace harness.

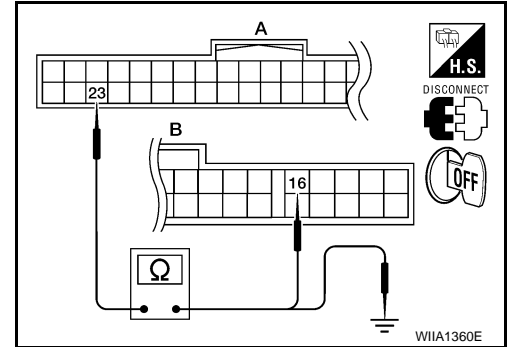

## Diagnosis Procedure 3

INFOID:000000004407802

### FRONT DOOR LOCK ASSEMBLY LH (KEY CYLINDER SWITCH) CHECK

#### 1.FRONT DOOR LOCK ASSEMBLY LH (KEY CYLINDER SWITCH) CHECK

Check front door lock assembly LH (key cylinder switch) with key.

#### Do doors lock/unlock when using the key?

- YES >> Front door lock assembly LH (key cylinder switch) is OK.
- NO >> Check front door lock assembly LH (key cylinder switch) circuit. Refer to [BL-135](#).

## Diagnosis Procedure 4

INFOID:000000004407803

### VEHICLE SECURITY HORN ALARM CHECK

#### 1.CHECK HORN OPERATION

Check if horn sounds with horn switch.

#### Does horn operate?

- YES >> Check harness for open or short between IPDM E/R and horn relay.
- NO >> Check horn circuit. Refer to [WW-27](#).

## Diagnosis Procedure 5

INFOID:000000004407804

### VEHICLE SECURITY HEADLAMP ALARM CHECK

#### 1.CHECK VEHICLE SECURITY HEADLAMP ALARM OPERATION

Check if headlamps operate with lighting switch.

#### Do headlamps come on when turning switch ON?

- YES >> Headlamp alarm is OK.
- NO >> Check headlamp system. Refer to [LT-4](#) or [LT-25](#).

## Diagnosis Procedure 6

INFOID:000000004407805

### DOOR LOCK/UNLOCK SWITCH CHECK

#### 1.CHECK DOOR LOCK/UNLOCK SWITCH INPUT SIGNAL

# VEHICLE SECURITY (THEFT WARNING) SYSTEM

## < SERVICE INFORMATION >

Check if power door lock operates with door lock/unlock switch.

Do doors lock/unlock when using each door lock/unlock switch?

YES >> Door lock/unlock switch is OK.

NO >> Refer to [BL-40. "Door Lock and Unlock Switch Check"](#).

## Diagnosis Procedure 7

INFOID:000000004407806

### TRUNK ROOM LAMP SWITCH CHECK

#### 1. CHECK TRUNK ROOM LAMP SWITCH INPUT SIGNAL

##### With CONSULT-III

Check ("TRUNK SW") in "DATA MONITOR" mode with CONSULT-III.

Monitor item	Trunk condition	
TRUNK SW	OPEN	: ON
	CLOSED	: OFF

##### Without CONSULT-III

1. Turn ignition switch OFF.
2. Check voltage between BCM harness connector M19 terminal 42 and ground.

Connector	Terminals		Trunk condition	Voltage (V) (Approx.)
	(+)	(-)		
M19	42	Ground	CLOSED	Battery voltage
			OPEN	0

##### OK or NG

OK >> Trunk room lamp switch circuit is OK.

NG >> GO TO 2.

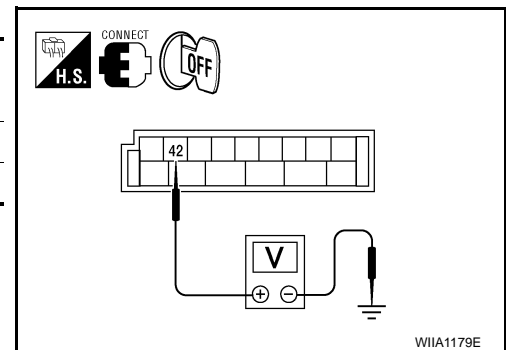

#### 2. CHECK TRUNK ROOM LAMP SWITCH

1. Turn ignition switch OFF.
2. Disconnect trunk room lamp switch connector.
3. Check continuity between trunk room lamp switch terminals 1 and 2.

Terminals		Trunk condition	Continuity
1	2		
		CLOSED	No
		OPEN	Yes

##### OK or NG

OK >> GO TO 3.

NG >> Replace trunk room lamp switch.

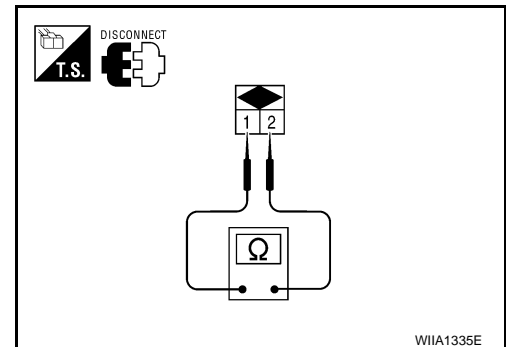

#### 3. CHECK TRUNK ROOM LAMP SWITCH CIRCUIT

1. Disconnect BCM connector M19.

# VEHICLE SECURITY (THEFT WARNING) SYSTEM

## < SERVICE INFORMATION >

2. Check continuity between BCM harness connector M19 (A) terminal 42 and trunk room lamp switch harness connector B57 (B) terminal 1.

**42 – 1 : Continuity should exist.**

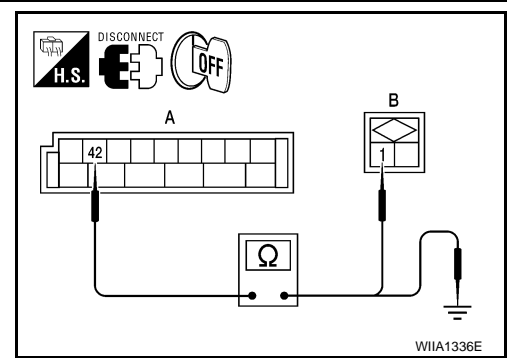

3. Check continuity between BCM harness connector M19 (A) terminal 42 and ground.

**42 – Ground : Continuity should not exist.**

### OK or NG

OK >> GO TO 4.

NG >> Repair or replace harness between BCM and trunk room lamp switch.

## 4. CHECK TRUNK ROOM LAMP SWITCH GROUND CIRCUIT

Check continuity between trunk room lamp switch harness connector B57 terminal 2 and ground.

**2 – Ground : Continuity should exist.**

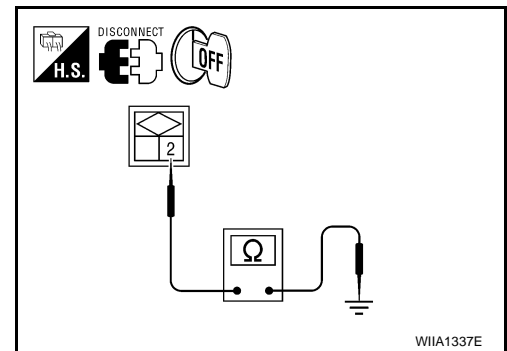

### OK or NG

OK >> Check connection of harness and connector.

NG >> Repair or replace trunk room lamp switch ground circuit.

# NATS(NISSAN ANTI-THEFT SYSTEM)

< SERVICE INFORMATION >

## NATS(NISSAN ANTI-THEFT SYSTEM)

### Component Parts and Harness Connector Location

INFOID:000000004407807

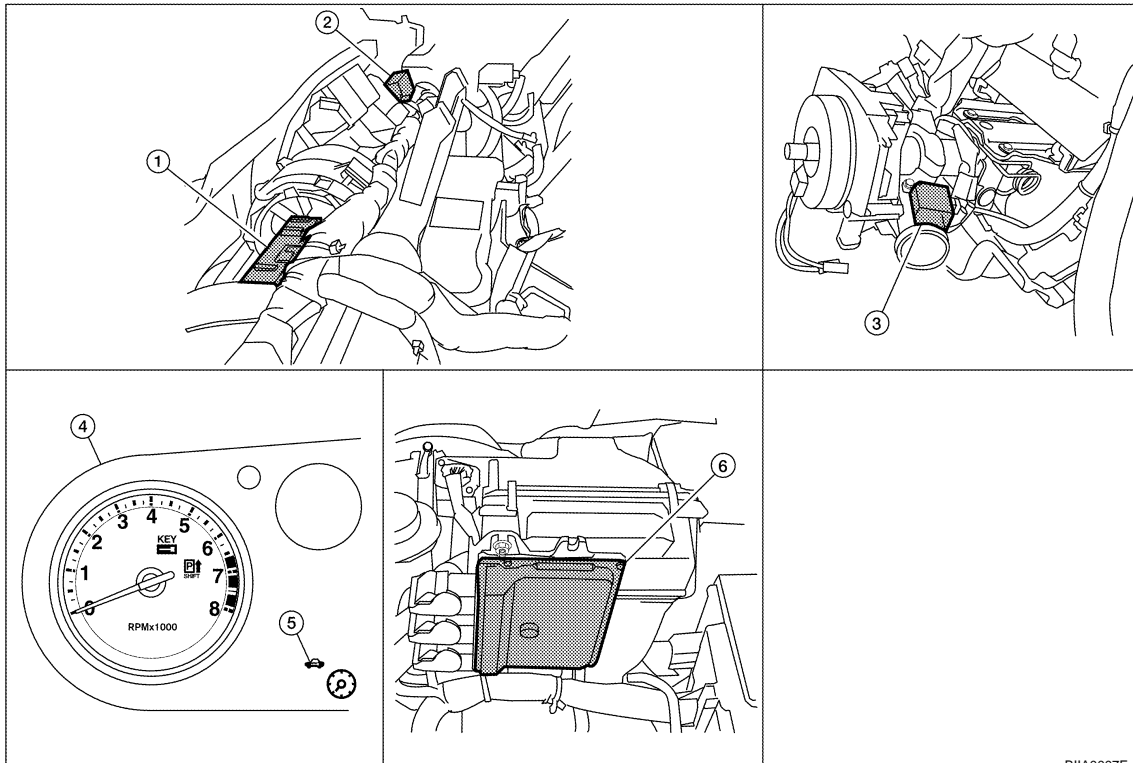

B1IA0007E

- |   |   |  |
|---|---|--|
| 1. BCM M18, M20<br>(view with instrument panel removed) | 2. Intelligent Key unit M42<br>(with Intelligent Key) | 3. NATS antenna amp. M21<br>(inside steering column) |
| 4. Combination meter M24                                | 5. Security indicator lamp                            | 6. ECM E16   |

### System Description

INFOID:000000004407808

#### DESCRIPTION

##### NOTE:

If customer reports a “No start” condition, request ALL KEYS to be brought to a Nissan dealer in case of a NATS malfunction.

NATS (Nissan Anti-Theft System) has the following functions:

- NATS shows a higher anti-theft performance at preventing engine to be started by an unregistered key. (registered key: mechanical key and Intelligent Key).
- Only a key with key ID registered in BCM and ECM can start engine, it has a higher protection against auto theft that duplicates keys.
- If a malfunction has been detected, security indicator will illuminate when ignition switch is in ON position.
- If the owner requires, mechanical key can be registered for up to 5 keys.
- During trouble diagnosis or when the following parts have been replaced, and if mechanical key is added, registration\* is required.

\*: All mechanical keys of the vehicle should be registered.

- ECM

- BCM

- Mechanical key

- NATS trouble diagnoses, system initialization and additional registration of other NATS mechanical key IDs must be carried out using CONSULT-III. When NATS initialization has been completed, the ID of the inserted mechanical key can be displayed.

Regarding the procedures of NATS initialization and mechanical key ID registration, refer to CONSULT-III operation manual.

#### SECURITY INDICATOR

- Forewarns that the vehicle is equipped with NATS.

# NATS(NISSAN ANTI-THEFT SYSTEM)

## < SERVICE INFORMATION >

- Security indicator will not blink while the ignition knob is in ON or START state.

### NOTE:

Because security indicator is highly efficient, the battery is barely affected.

### Condition of Security Indicator

- When operating the ignition switch with Intelligent Key, security indicator lamp will turn off at once if ignition switch is pressed and blinks when ignition switch is released.
- When operating the ignition switch with mechanical key security indicator will turn off at once if mechanical key is inserted into key cylinder and blinks when mechanical key is removed.  
(Once the mechanical key is inserted into key cylinder, BCM will only perform the key ID verification with mechanical key)

## System Composition

INFOID:000000004407809

The function of the NATS consists of the following:

- Mechanical key
- NATS antenna amp. located in the ignition key cylinder
- BCM
- ECM (Engine control module)
- Security indicator
- Intelligent Key unit (with Intelligent Key)

### NOTE:

The communication between ECM, BCM and/or Intelligent Key unit uses the CAN communication system.

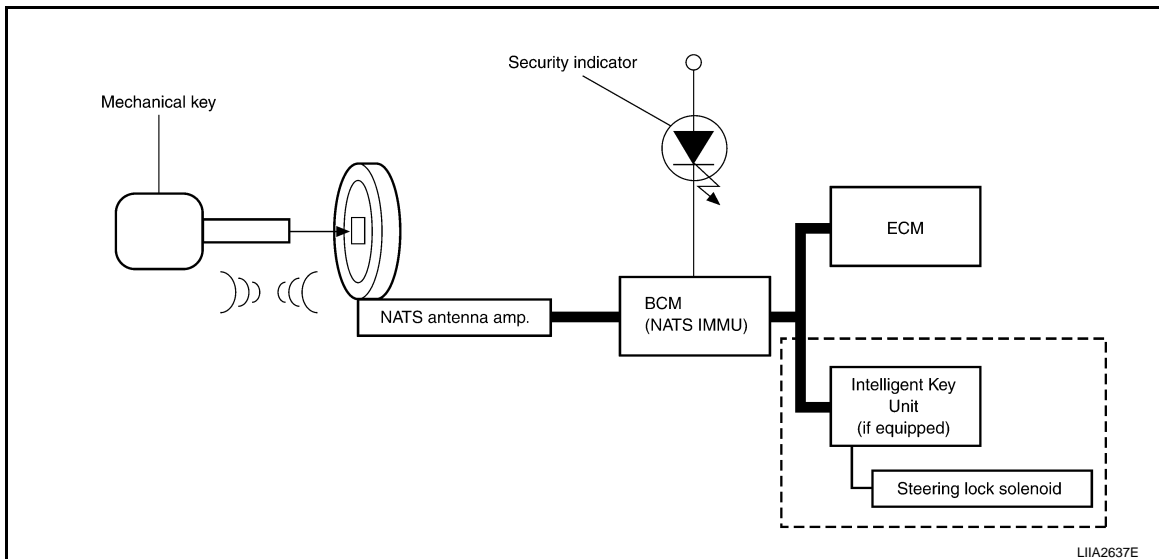

## ECM Re-communicating Function

INFOID:000000004407810

Performing the following procedure can automatically perform re-communication of ECM and BCM or Intelligent Key unit, but only when the ECM has been replaced with a new one which has never been energized on-board.

(In this step, initialization procedure by CONSULT-III is not necessary)

### NOTE:

- When registering new Key IDs or replacing the ECM other than brand new, refer to CONSULT-III Operation Manual.
- If multiple keys are attached to the key holder, separate them before work.
- Distinguish keys with unregistered key ID from those with registered ID.

1. Install ECM.
2. Use a registered key (\*), turn ignition switch to "ON".  
\*: To perform this step, use the key that has been used before to perform ECM replacement.
3. Maintain ignition switch in "ON" position for at least 5 seconds.
4. Turn ignition switch to "OFF".
5. Start engine.  
If engine can be started, procedure is completed.

# NATS(NISSAN ANTI-THEFT SYSTEM)

< SERVICE INFORMATION >

If engine cannot be started, refer to CONSULT-III Operation Manual and initialize control unit.

## Wiring Diagram - NATS -

INFOID:000000004407811

BL-NATS-01

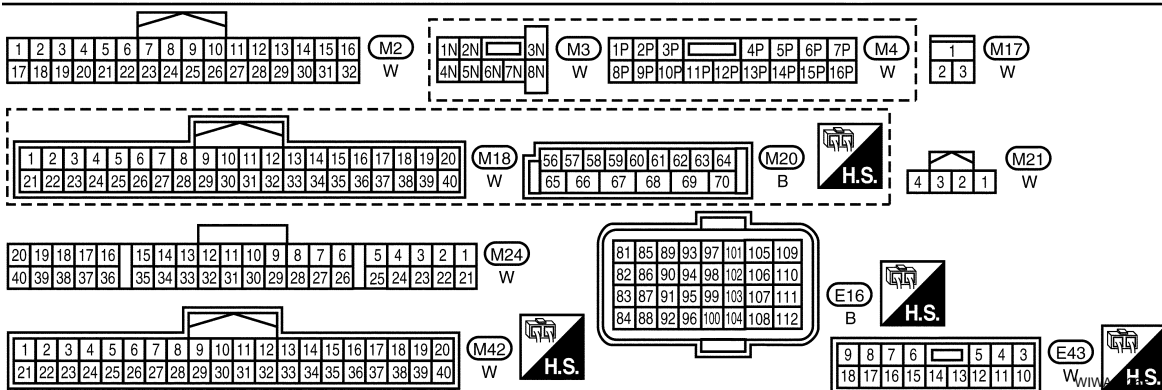
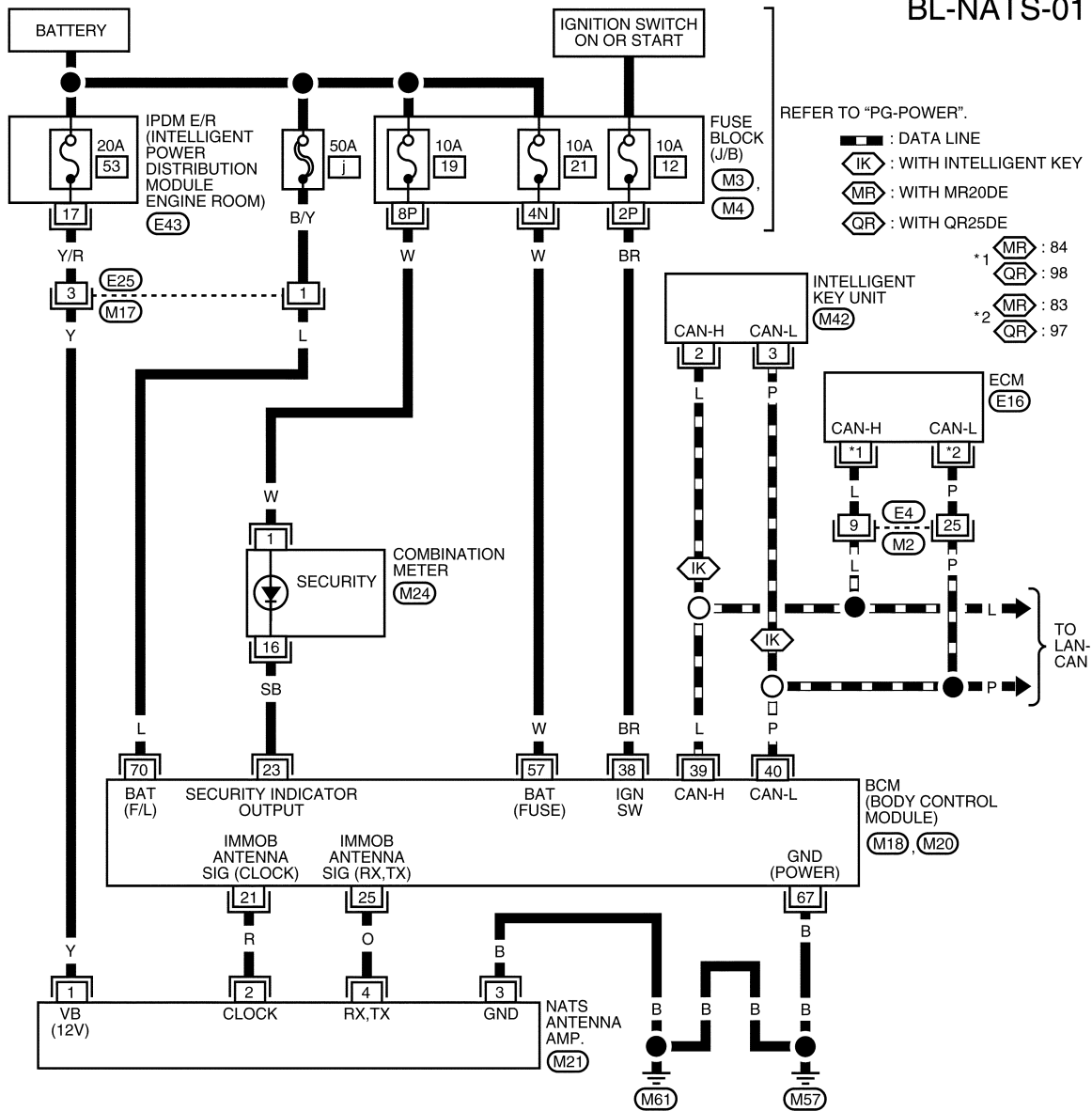

## Terminal and Reference Value for BCM

INFOID:000000004407812

Refer to [BCS-11, "Terminal and Reference Value for BCM"](#).



# NATS(NISSAN ANTI-THEFT SYSTEM)

< SERVICE INFORMATION >

## CONSULT-III Function

INFOID:000000004407813

### CONSULT-III DIAGNOSTIC TEST MODE FUNCTION

CONSULT-III DIAGNOSTIC TEST MODE	Description
C/U INITIALIZATION	When replacing any of the following components, C/U initialization and re-registration of all NATS mechanical keys are necessary. [NATS mechanical key/ BCM/ ECM*]
SELF-DIAG RESULTS	Detected items (screen terms) are as shown in the chart. Refer to "NATS SELF-DIAGNOSTIC RESULTS ITEM CHART".

\*: When replace ECM, refer to [BL-171, "ECM Re-communicating Function"](#).

#### NOTE:

- When any initialization is performed, all ID previously registered will be erased and all NATS mechanical keys must be registered again.
- The engine cannot be started with an unregistered key. In this case, the system will show "DIFFERENCE OF KEY" or "LOCK MODE" as a self-diagnostic result on the CONSULT-III screen.
- In rare case, "CHAIN OF ECM-IMMU" might be stored as a self-diagnostic result during key registration procedure, even if the system is not malfunctioning.

### NATS SELF-DIAGNOSTIC RESULTS ITEM CHART

Detected items [NATS program card screen terms]	P No. Code (Self-diagnostic result of "ENGINE")	Malfunction is detected when.....	Reference page
CHAIN OF ECM-IMMU [P1612]	NATS MAL-FUNCTION P1612	Communication impossible between ECM and BCM In rare case, "CHAIN OF ECM-IMMU" might be stored during key registration procedure, even if the system is not malfunctioning.	<a href="#">BL-177</a>
DIFFERENCE OF KEY [P1615]	NATS MAL-FUNCTION P1615	BCM can receive the key ID signal but the result of ID verification between key ID and BCM is NG.	<a href="#">BL-182</a>
CHAIN OF IMMU-KEY [P1614]	NATS MAL-FUNCTION P1614	BCM cannot receive the key ID signal.	<a href="#">BL-178</a>
ID DISCORD, IMM-ECM [P1611]	NATS MAL-FUNCTION P1611	The result of ID verification between BCM and ECM is NG. System initialization is required.	<a href="#">BL-180</a>
LOCK MODE [P1610]	NATS MAL-FUNCTION P1610	When the starting operation is carried out five or more times consecutively under the following conditions, NATS will shift the mode to one which prevents the engine from being started. <ul style="list-style-type: none"> <li>• Unregistered mechanical key is used.</li> <li>• BCM or ECM's malfunctioning.</li> </ul>	<a href="#">BL-181</a>
DON'T ERASE BEFORE CHECKING ENG DIAG	—	All engine trouble codes except NATS trouble code has been detected in ECM.	<a href="#">BL-173</a>

### Trouble Diagnosis Procedure

INFOID:000000004407814

#### PRELIMINARY CHECK

##### 1.GET SYMPTOMS

Listen to customer complaints request. (Get symptoms)

#### NOTE:

If customer reports a "No start" condition, request all Intelligent Keys to be brought to the dealer in case of Intelligent Key system malfunction.

# NATS(NISSAN ANTI-THEFT SYSTEM)

## < SERVICE INFORMATION >

---

Intelligent Key or mechanical key service request>> For further information, refer to CONSULT-III operation manual.

Malfunctions>>GO TO 2.

### 2.START ENGINE WITH INTELLIGENT KEY (WITH INTELLIGENT KEY)

---

Check if the engine could be started by all registered Intelligent Keys.

The engine cannot be started by some Intelligent Keys>>Intelligent Key is low battery or malfunction. Refer to [BL-128. "Intelligent Key Battery Replacement"](#).

The engine cannot be started by all Intelligent Keys>>GO TO 3.

The engine can be started by all Intelligent Keys>>GO TO 4.

### 3.CHECK "KEY" WARNING LAMP ILLUMINATION

---

When pushing the ignition switch, check if "KEY" warning lamp in combination meter illuminates.

KEY warning lamp illuminates green>>GO TO [BL-126. ""KEY" Warning Lamp \(GREEN\) Check"](#).

KEY warning lamp illuminates red>>GO TO [BL-126. ""KEY" Warning Lamp \(RED\) Check"](#).

Does not illuminate>>GO TO [BL-99. "Trouble Diagnosis Symptom Chart"](#).

### 4.START ENGINE WITH MECHANICAL KEY

---

Check if the engine could be started by all registered mechanical keys.

The engine can not be started by some mechanical keys>>Register mechanical key. Refer to CONSULT-III operation manual.

The engine cannot be started by all mechanical keys>> "WORK FLOW".

The engine can be started by all mechanical keys>>GO TO 5.

### 5.PERFORM SELF-DIAGNOSIS

---

1. Turn ignition switch to ON by carrying the Intelligent Key.

2. Perform self-diagnosis of Intelligent Key system with CONSULT-III.

Malfunction is detected>>GO TO [BL-97. "CONSULT-III Application Item"](#).

No malfunction is detected>>GO TO [BL-94. "Trouble Diagnosis Procedure"](#).

## WORK FLOW

### 1.STARTING ENGINE

---

Check if the engine could be started by inserting the mechanical key into the ignition key cylinder and operate ignition switch.

OK >> System is normal.

NG >> GO TO 2.

### 2.PERFORM SELF DIAGNOSIS

---

Perform SELF-DIAGNOSIS "NATS V5.0" using CONSULT-III.

#### **NOTE:**

NATS program card is necessary to display the "SELF-DIAGNOSIS".

No malfunction is detected>>Recheck the starting engine section GO TO 1.

Malfunction related to NATS is detected>>GO TO 3.

Malfunctions related to "DON'T ERASE BEFORE CHECKING ENG DIAG" and NATS are detected>>GO TO 7.

### 3.IDENTIFYING NATS MALFUNCTION

---

Self-diagnosis results referring to NATS, but no information about engine self-diagnosis result is displayed on CONSULT-III. Refer to [BL-176. "Trouble Diagnosis"](#).

>> GO TO 4.

# NATS(NISSAN ANTI-THEFT SYSTEM)

< SERVICE INFORMATION >

---

## 4.NATS TROUBLE DIAGNOSIS

---

Repair NATS (if necessary, perform "C/U INITIALIZATION" with CONSULT-III.)

>> GO TO 5.

## 5.ERASE SELF-DIAGNOSIS

---

Erase the record of "SELF-DIAGNOSIS" by using CONSULT-III.

>> GO TO 6.

## 6.STARTING ENGINE

---

Check if the engine could be started by inserting the mechanical key into the ignition key cylinder and operate ignition switch.

NG >> GO TO 2.

OK >> End of inspection.

## 7.IDENTIFYING NATS AND ENGINE CONTROL MALFUNCTION

---

NATS malfunction and "DON'T ERASE BEFORE CHECKING ENG DIAG" are displayed on the CONSULT-III screen.

### NOTE:

This indication means that malfunction have been detected in NATS and engine control system.

>> GO TO 8.

## 8.NATS TROUBLE DIAGNOSIS

---

Repair NATS according to self-diagnosis results refer to NATS (if necessary, perform "C/U INITIALZATION" with CONSULT-III.)

### NOTE:

Do not erase "SELF-DIAGNOSIS" by using CONSULT-III.

>> GO TO 9.

## 9.IDENTIFYING ENGINE CONTROL MALFUNCTION

---

Check engine "SELF-DIAGNOSIS" records with a generalized program card instead of the NATS program card.

>> GO TO 10.

## 10.ENGINE CONTROL SYSTEM TROUBLE DIAGNOSIS

---

Repair engine control system if engine related malfunction is detected.

With engine diagnostic codes present, refer to [EC-23](#).

Without engine diagnostic codes present, refer to [EC-35](#).

### NOTE:

If only "NATS MALFUNCTION" is displayed, erase the self-diagnosis results.

>> GO TO 11.

## 11.STARTING ENGINE

---

Check if the engine could be started by inserting the mechanical key into the ignition key cylinder and operate ignition switch.

OK >> GO TO 12.

NG >> GO TO 2.

A  
B  
C  
D  
E  
F  
G  
H  
J  
K  
L  
M  
N  
O  
P

BL

# NATS(NISSAN ANTI-THEFT SYSTEM)

< SERVICE INFORMATION >

## 12.ERASE SELF-DIAGNOSIS

Erase both NATS and ENGINE "SELF-DIAGNOSIS" records by using CONSULT-III NATS program card and generalized program card.

>> GO TO 13

## 13.COMFIRMATION

Perform running test with CONSULT-III in engine "SELF-DIAGNOSIS" mode.

"NO DTC" is displayed>> End of inspection.  
Malfunction information is displayed>>GO TO 2.

## Trouble Diagnosis

INFOID:000000004407815

### SYMPTOM MATRIX CHART 1

Self-diagnosis related item

SYMPTOM	Displayed "SELF-DIAG RESULTS" on CONSULT-III screen.	DIAGNOSTIC PROCEDURE (Reference page)	SYSTEM (Malfunctioning part or mode)
<ul style="list-style-type: none"> <li>Security indicator lighting up*</li> <li>Engine cannot be started</li> </ul>	CHAIN OF ECM-IMMU [P1612]	PROCEDURE 1 (BL-177)	In rare case, "CHAIN OF ECM-IMMU" might be stored during key registration procedure, even if the system is not malfunctioning.
			Open circuit in battery voltage line of BCM circuit
			Open circuit in ignition line of BCM circuit
			Open circuit in ground line of BCM circuit
			Open or short circuit between BCM and ECM communication line
			ECM
	BCM		
	DIFFERENCE OF KEY [P1615]	PROCEDURE 6 (BL-182)	Unregistered ignition key is used.
			BCM is malfunctioning.
	CHAIN OF IMMU-KEY [P1614]	PROCEDURE 2 (BL-178)	Malfunction of key ID chip
Communication line between ANT/ AMP and BCM: Open circuit or short circuit of battery voltage line or ground line			
Open circuit in power source line of ANT/ AMP circuit			
Open circuit in ground line of ANT/ AMP circuit			
NATS antenna amp.			
BCM			
ID DISCORD, IMM-ECM [P1611]	PROCEDURE 3 (BL-180)	System initialization has not yet been completed.	
		ECM	
LOCK MODE [P1610]	PROCEDURE 5 (BL-181)	When the starting operation is carried out five or more times consecutively under the following conditions, NATS will shift the mode to one which prevents the engine from being started. <ul style="list-style-type: none"> <li>Unregistered ignition key is used.</li> <li>BCM or ECM's malfunctioning.</li> </ul>	
Security indicator lighting up*	DON'T ERASE BEFORE CHECKING ENG DIAG	WORK FLOW (BL-173)	Engine trouble data and NATS trouble data have been detected in ECM

\*: When NATS detects trouble, the security indicator lights up while ignition key is in the "ON" position.

### SYMPTOM MATRIX CHART 2

# NATS(NISSAN ANTI-THEFT SYSTEM)

## < SERVICE INFORMATION >

Non self-diagnosis related item

SYMPTOM	DIAGNOSTIC PROCEDURE (Reference page)	SYSTEM (Malfunctioning part or mode)
Security indicator does not light up*.	PROCEDURE 4 (BL-180)	Security indicator.
		Open circuit between Fuse and BCM
		BCM

\*: CONSULT-III self-diagnostic results display screen "no malfunction is detected".

## Diagnosis Procedure 1

INFOID:000000004407816

### Self-diagnostic results:

"CHAIN OF ECM-IMMU" displayed on CONSULT-III screen

First perform the "SELF-DIAG RESULTS" in "BCM" with CONSULT-III, then perform the trouble diagnosis of malfunction system indicated "SELF-DIAG RESULTS" of "BCM". Refer to [BCS-16. "CAN Communication Inspection Using CONSULT-III \(Self-Diagnosis\)".](#)

### 1. CONFIRM SELF-DIAGNOSTIC RESULTS

Confirm SELF-DIAGNOSTIC RESULTS "CHAIN OF ECM-IMMU" displayed on CONSULT-III screen.

#### NOTE:

In rare case, "CHAIN OF ECM-IMMU" might be stored during key registration procedure, even if the system is not malfunctioning.

Is CONSULT-III screen displayed as shown above [P1612]?

Yes >> GO TO 2.

No >> GO TO [BL-176. "Trouble Diagnosis".](#)

### 2. CHECK POWER SUPPLY CIRCUIT FOR BCM

- Turn ignition switch OFF.
- Check voltage between BCM and ground with CONSULT-III or tester.

BCM connector	Terminals		Voltage [V] (Approx.)
	(+)	(-)	
M20	57	Ground	Battery voltage
	70		

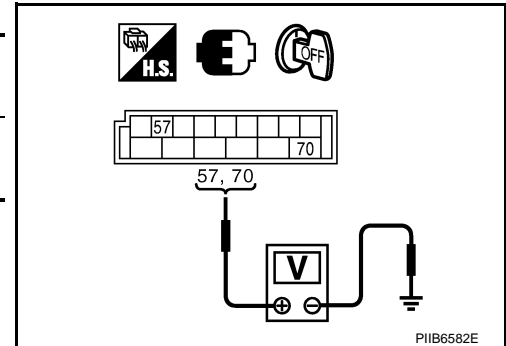

#### OK or NG

OK >> GO TO 3.

NG >> Check the following.

- 50A fusible link (letter j, located in the fuse and fusible link box).
- 10A fuse [No.21, located in the fuse block (J/B)].
- Harness for open or short between fusible link and BCM.
- Harness for open or short between fuse and BCM.

### 3. CHECK IGNITION SWITCH ON SIGNAL

- Turn ignition switch ON.
- Check voltage between BCM connector and ground with CONSULT-III or tester.

BCM connector	Terminal		Voltage [V] (Approx.)
	(+)	(-)	
M18	38	Ground	Battery voltage

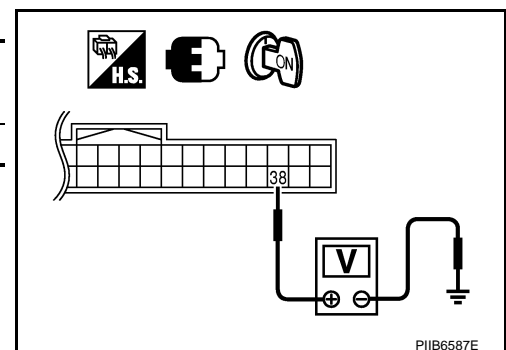

#### OK or NG

OK >> GO TO 4.

NG >> Check the following.

- 10A fuse [No. 12, located in the fuse block (J/B)].
- Harness for open or short between fuse and BCM.

# NATS(NISSAN ANTI-THEFT SYSTEM)

< SERVICE INFORMATION >

## 4.CHECK GROUND CIRCUIT FOR BCM

1. Turn ignition switch OFF.
2. Disconnect BCM connector.
3. Check continuity between BCM connector and ground.

BCM connector	Terminal		Continuity
	(+)	(-)	
M20	67	Ground	Yes

### OK or NG

- OK >> GO TO 5.  
NG >> Repair or replace harness.

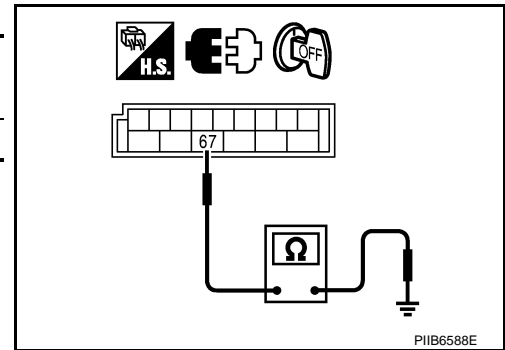

## 5.REPLACE BCM

1. Replace BCM.
2. Perform initialization with CONSULT-III.  
For initialization, refer to "CONSULT-III Operation Manual".

### Does the engine start?

- Yes >> BCM is malfunctioning.
- Replace BCM. Refer to [BCS-17, "Removal and Installation of BCM"](#).
  - Perform initialization with CONSULT-III
  - For initialization, refer to "CONSULT-III Operation Manual"
- No >> ECM is malfunctioning.
- Replace ECM.
  - Perform initialization or re-communicating function
  - For initialization, refer to "CONSULT-III Operation Manual"
  - For re-communicating function, refer to [BL-171, "ECM Re-communicating Function"](#)

## Diagnosis Procedure 2

INFOID:000000004407817

### Self-diagnostic results:

"CHAIN OF IMMU-KEY" displayed on CONSULT-III screen

## 1.CONFIRM SELF-DIAGNOSTIC RESULTS

Confirm SELF-DIAGNOSTIC RESULTS "CHAIN OF IMMU-KEY" displayed on CONSULT-III screen.

Is CONSULT-III screen displayed as shown above [P1614]?

- Yes >> GO TO 2.  
No >> GO TO [BL-176, "Trouble Diagnosis"](#)

## 2.CHECK NATS ANTENNA AMP. INSTALLATION

Check NATS antenna amp. installation. Refer to [BL-182, "How to Replace NATS Antenna Amp"](#).

### OK or NG

- OK >> GO TO 3.  
NG >> Reinstall NATS antenna amp. correctly.

## 3.CHECK NATS IGNITION KEY ID CHIP

Start engine with another registered NATS ignition key.

Does the engine start?

- Yes >> Ignition key ID chip is malfunctioning.
- Replace the ignition key
  - Perform initialization with CONSULT-III
- For initialization, refer to "CONSULT-III Operation Manual"
- No >> GO TO 4.

## 4.CHECK POWER SUPPLY FOR NATS ANTENNA AMP.

# NATS(NISSAN ANTI-THEFT SYSTEM)

## < SERVICE INFORMATION >

1. Turn ignition switch "OFF".
2. Check voltage between NATS antenna amp. connector and ground.

NATS antenna amp. connector	Terminal		Voltage [V] (Approx.)
	(+)	(-)	
M21	1	Ground	Battery voltage

### OK or NG

- OK >> GO TO 5.  
 NG >> Check the following.
- 20A fuse [No. 53, located in IPDM E/R]
  - Harness for open or short between fuse and NATS antenna amp.

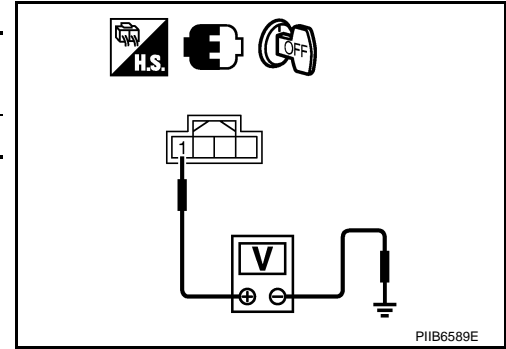

## 5.CHECK NATS ANTENNA AMP. SIGNAL LINE- 1

Check voltage between NATS antenna amp. connector and ground with analog tester.

NATS antenna amp. connector	Terminal		Conditions	Status of Voltage and tester
	(+)	(-)		
M21	2	Ground	Before tuning ignition switch to ON	Approx. 0 [V]
			Right after tuning ignition switch to ON	Pointer of tester should move

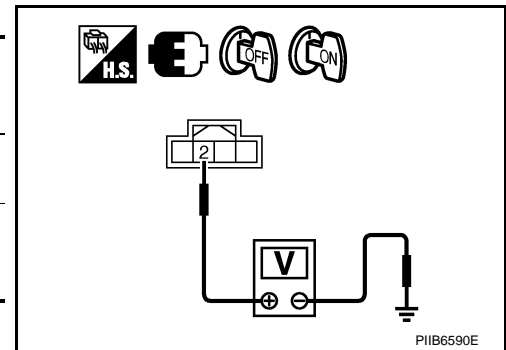

### OK or NG

- OK >> GO TO 6.  
 NG >> • Check harness for open or short between NATS antenna amp. and BCM.

#### NOTE:

If harness is OK, replace BCM, perform initialization with CONSULT-III. For initialization, refer to "CONSULT-III Operation Manual".

## 6.CHECK NATS ANTENNA AMP. SIGNAL LINE- 2

Check voltage between NATS antenna amp. connector and ground with analog tester.

NATS antenna amp. connector	Terminal		Conditions	Status of Voltage and tester
	(+)	(-)		
M21	4	Ground	Before tuning ignition switch to ON	Approx. 0 [V]
			Right after tuning ignition switch to ON	Pointer of tester should move

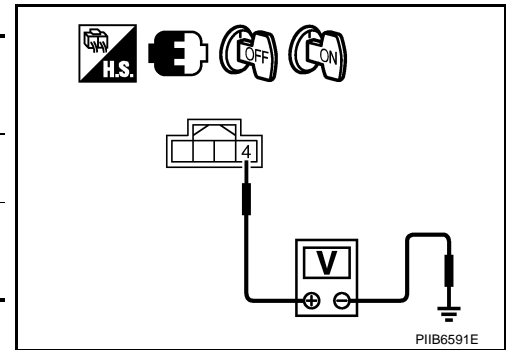

### OK or NG

- OK >> GO TO 7.  
 NG >> • Check harness for open or short between NATS antenna amp. and BCM.

#### NOTE:

If harness is OK, replace BCM, perform initialization with CONSULT-III. For initialization, refer to "CONSULT-III Operation Manual".

## 7.CHECK NATS ANTENNA AMP. GROUND LINE CIRCUIT

1. Turn ignition switch "OFF".
2. Disconnect NATS antenna amp. connector.
3. Check continuity between NATS antenna amp. connector and ground.

# NATS(NISSAN ANTI-THEFT SYSTEM)

## < SERVICE INFORMATION >

NATS antenna amp. connector	Terminal		Continuity
	(+)	(-)	
M21	3	Ground	Yes

### OK or NG

- OK >> NATS antenna amp. is malfunctioning, reinstall antenna or replace it.
- NG >> Repair or replace NATS antenna amp. ground circuit.

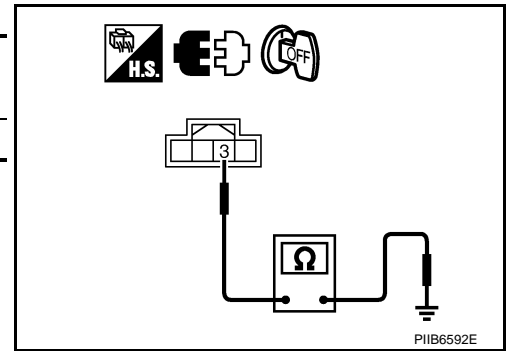

INFOID:000000004407818

## Diagnosis Procedure 3

### Self-diagnostic results:

“ID DISCORD, IMM-ECM” displayed on CONSULT-III screen

### 1. CONFIRM SELF-DIAGNOSTIC RESULTS

Confirm SELF-DIAGNOSTIC RESULTS “ID DISCORD, IMM-ECM” displayed on CONSULT-III screen.

#### NOTE:

“ID DISCORD IMM-ECM”:

Registered ID of BCM is in discord with that of ECM.

Is CONSULT-III screen displayed as shown above [P1611]?

- YES >> GO TO 2.
- NO >> GO TO [BL-176. "Trouble Diagnosis"](#).

### 2. PERFORM INITIALIZATION WITH CONSULT-III

Perform initialization with CONSULT-III. Re-register all NATS ignition key IDs.

For initialization, refer to “CONSULT-III Operation Manual”.

#### NOTE:

If the initialization is not completed or malfunctions, CONSULT-III shows message on the screen [INITIALIZATION FAIL].

Can the system be initialized?

- YES >> • Start engine. (END)
- (System initialization had not been completed.)
- NO >> ECM is malfunctioning.
- Replace ECM.
  - Perform initialization with CONSULT-III
- For initialization, refer to “CONSULT-III Operation Manual”

## Diagnosis Procedure 4

INFOID:000000004407819

“COMBINATION METER (SECURITY) DOES NOT LIGHT UP”

### 1. CHECK FUSE

Check 10A fuse [No.19, located in the fuse block (J/B)]

### OK or NG

- OK >> GO TO 2.
- NG >> Replace fuse.

### 2. CHECK COMBINATION METER (SECURITY)

1. Install 10A fuse.
2. Start engine and turn ignition switch OFF.
3. Check if the combination meter (security) lights up.

**Combination meter (security) should light up.**

### OK or NG

- OK >> Inspection End.
- NG >> GO TO 3.



# NATS(NISSAN ANTI-THEFT SYSTEM)

< SERVICE INFORMATION >

## 3.CHECK COMBINATION METER (SECURITY) POWER SUPPLY CIRCUIT

1. Disconnect combination meter (security) connector.
2. Check voltage between combination meter (security) connector and ground.

Combination meter (security) connector	Terminal		Voltage [V] (Approx.)
	(+)	(-)	
M24	1	Ground	Battery voltage

**OK or NG**

- OK >> GO TO 4.  
 NG >> Check harness for open or short between fuse and combination meter (security).

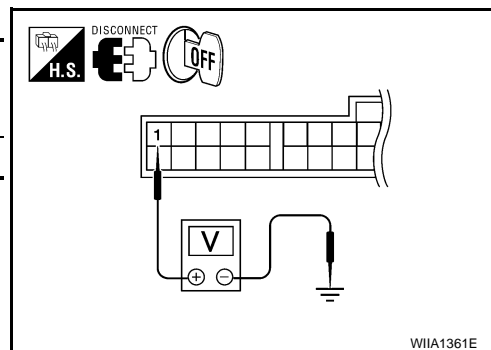

## 4.CHECK BCM FUNCTION

1. Connect combination meter (security) connector.
2. Disconnect BCM connector.
3. Check voltage between BCM connector and ground.

BCM connector	Terminal		Voltage [V] (Approx.)
	(+)	(-)	
M18	23	Ground	Battery voltage

**OK or NG**

- OK >> BCM is malfunctioning.
- Replace BCM. Refer to [BCS-17. "Removal and Installation of BCM"](#).
  - Perform initialization with CONSULT-III
  - For initialization, refer to "CONSULT-III Operation Manual"
- NG >> Check the following.
- Harness for open or short between combination meter (security) and BCM
  - Indicator lamp condition

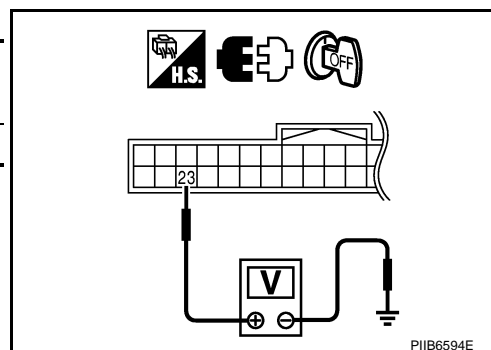

## Diagnosis Procedure 5

INFOID:000000004407820

**Self-diagnostic results:**

**"LOCK MODE" displayed on CONSULT-III screen**

### 1.CONFIRM SELF-DIAGNOSTIC RESULTS

Confirm SELF-DIAGNOSTIC RESULTS "LOCK MODE" is displayed on CONSULT-III screen.

Is CONSULT-III screen displayed as shown above [P1610]?

- YES >> GO TO 2.  
 NO >> GO TO [BL-176. "Trouble Diagnosis"](#).

### 2.ESCAPE FROM LOCK MODE

1. Turn ignition switch OFF.
2. Turn ignition switch ON with registered key. (Do not start engine.) Wait 5 seconds.
3. Return the key to OFF position. Wait 5 seconds.
4. Repeat steps 2 and 3 twice (total of three cycles).
5. Start the engine.

Does engine start?

- YES >> System is OK (Now system is escaped from "LOCK MODE").  
 NO >> GO TO 3.

### 3.PERFORM INITIALIZATION WITH CONSULT-III

Perform initialization with CONSULT-III.

# NATS(NISSAN ANTI-THEFT SYSTEM)

## < SERVICE INFORMATION >

For initialization, refer to "CONSULT-III Operation Manual".

### NOTE:

If the initialization is not completed or malfunctions, CONSULT-III shows the message on the screen [INITIALIZATION FAIL].

### Can the system be initialized?

- YES >> System is OK.
- NO >> GO TO 4.

## 4.PERFORM INITIALIZATION WITH CONSULT-III AGAIN

1. Replace BCM.
2. Perform initialization with CONSULT-III.  
For initialization, refer to "CONSULT-III Operation Manual".

### NOTE:

If the initialization is not completed or malfunctions, CONSULT-III shows the message on the screen [INITIALIZATION FAIL].

### Can the system be initialized?

- YES >> System is OK. (BCM is malfunctioning.)
- NO >> ECM is malfunctioning.
  - Replace ECM.
  - Perform initialization with CONSULT-III
  - For initialization, refer to "CONSULT-III Operation Manual"

## Diagnosis Procedure 6

INFOID:000000004407821

### Self-diagnostic results:

"DIFFERENCE OF KEY" displayed on CONSULT-III screen

## 1.CONFIRM SELF-DIAGNOSTIC RESULTS

Confirm SELF-DIAGNOSTIC RESULTS "DIFFERENCE OF KEY" displayed on CONSULT-III screen.

### Is "DIFFERENCE OF KEY" displayed?

- YES >> GO TO 2.
- NO >> GO TO [BL-176. "Trouble Diagnosis"](#).

## 2.PERFORM INITIALIZATION WITH CONSULT-III

Perform initialization with CONSULT-III. Re-register all NATS ignition key IDs.  
For initialization and registration of NATS ignition key IDs, refer to CONSULT-III Operation Manual.

### NOTE:

If the initialization is not completed or malfunctions, CONSULT-III shows message on the screen.

### Can the system be initialized and can the engine be started with re-registered NATS ignition key?

- YES >> • Ignition key ID was unregistered.
- NO >> • BCM is malfunctioning.
  - Replace BCM. Refer to [BCS-17. "Removal and Installation of BCM"](#).
  - Perform initialization with CONSULT-III.
  - For initialization, refer to CONSULT-III Operation Manual.

## How to Replace NATS Antenna Amp

INFOID:000000004407822

### NOTE:

- If NATS antenna amp. is not installed correctly, NATS system will not operate properly and SELF-DIAG RESULTS on CONSULT-III screen will show "LOCK MODE" or "CHAIN OF IMMUNE KEY".
- Initialization is not necessary only when NATS antenna amp. is replaced with a new one.

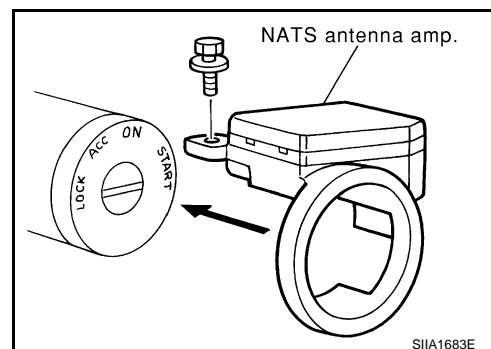

# BODY REPAIR

< SERVICE INFORMATION >

## BODY REPAIR

### Body Exterior Paint Color

INFOID:000000004407823

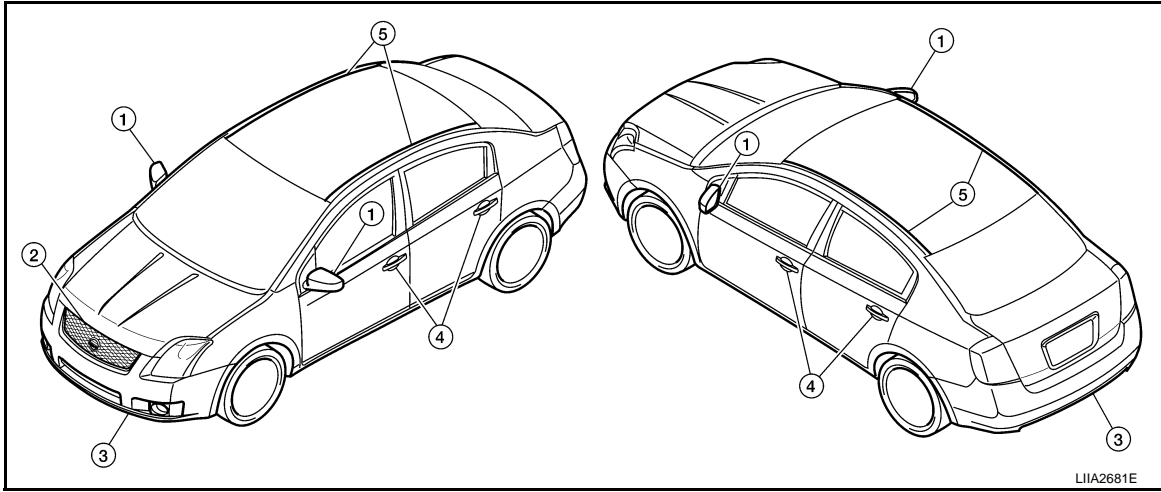

Component		Color code	A20	B17	B23	KAN	K23	NAC	K36	K37	KH3	HAB	QM1	RAF
		Description	Red Alert	Metallic Blue	Blue Onyx	Midnight Sky	Brilliant Silver	Red Brick	Magnetic Grey	Polished Granite	Super Black	Sonoran Sand	Fresh Powder	Artic Blue
		Paint type	S	M	M	S	M	P	M	M	S	M	S	M
		Hard clear coat	--	--	--	--	--	--	--	--	--	--	--	--
1	Outside mirror	Body color	A20	B17	B23	KAN	K23	NAC	K36	K37	KH3	HAB	QM1	RAF
2	Radiator grille	Chromium-plate + Black	Cr2P + G02-1	Cr2P + G02-1	Cr2P + G02-1	Cr2P + G02-1	Cr2P + G02-1	Cr2P + G02-1	Cr2P + G02-1	Cr2P + G02-1	Cr2P + G02-1	Cr2P + G02-1	Cr2P + G02-1	Cr2P + G02-1
3	Bumper fascia	Body color	A20	B17	B23	KAN	K23	NAC	K36	K37	KH3	HAB	QM1	RAF
4	Outside handle	Body color	A20	B17	B23	KAN	K23	NAC	K36	K37	KH3	HAB	QM1	RAF
5	Roof ditch molding	Body color	A20	B17	B23	KAN	K23	NAC	K36	K37	KH3	HAB	QM1	RAF

M: Metallic; 2S: 2-Coat Solid, 2P: 2-Coat Pearl; 3P: 3-Coat Pearl; PM: Pearl Metallic; TM: Micro Titanium Metallic; G01-1: Material color; G02-1: Material color

# BODY REPAIR





< SERVICE INFORMATION >

## Body Component Parts

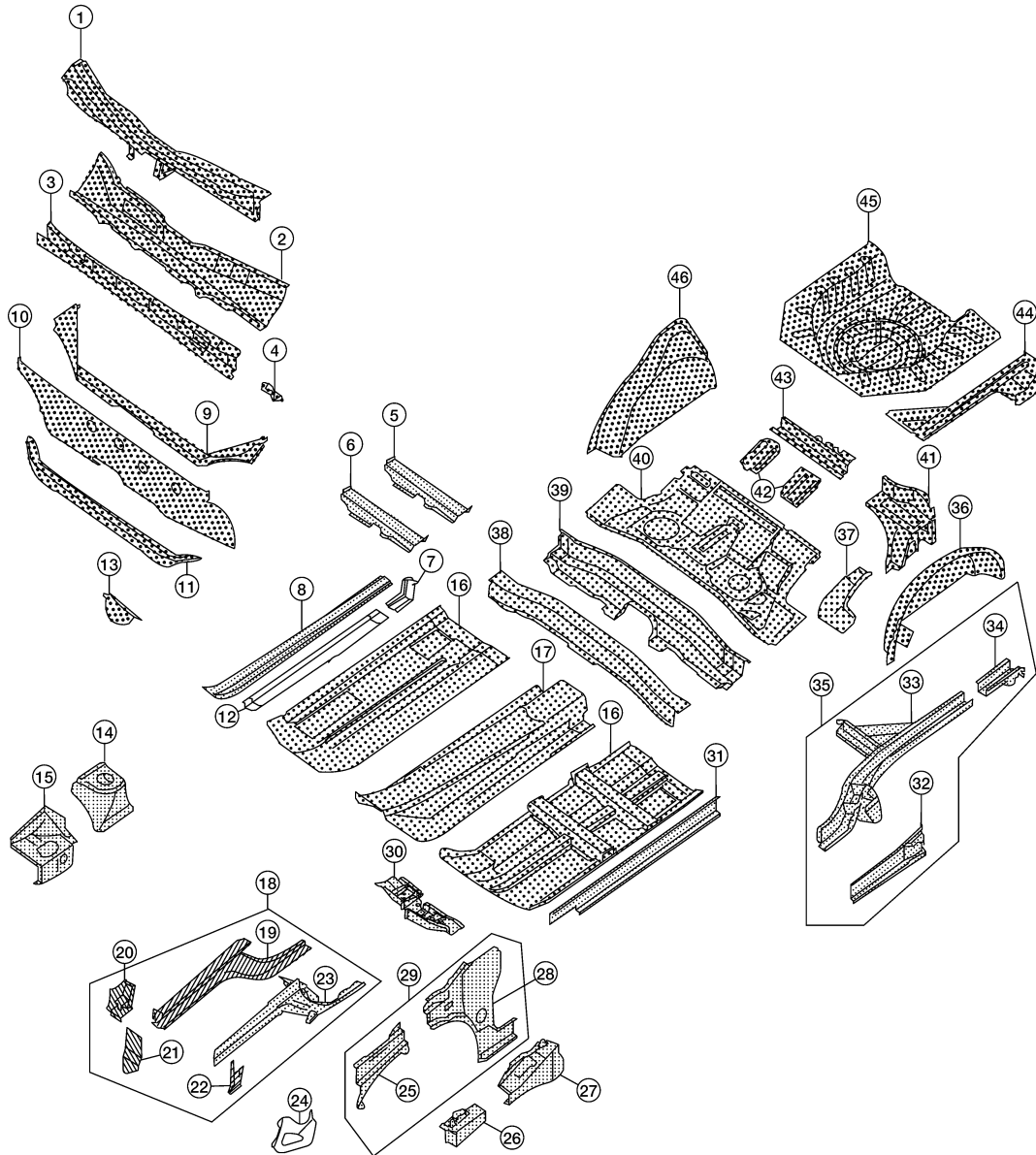
INFOID:000000004407824

### UNDERBODY COMPONENT PARTS



-  : Indicates bothsided anti-corrosive precoated steel portions
-  : Indicates high strength steel (HSS) portions
-  : Indicates both sided anti-corrosive steel and HSS portions
-  \*Indicates aluminum portion

LIA2682E

1. Cowl top assembly
2. Upper dash assembly
3. Upper dash crossmember

## BODY REPAIR

### < SERVICE INFORMATION >

---

4. Cowl top extension member (RH & LH)	A
5. 3rd crossmember assembly (RH & LH)	
6. 2nd crossmember (RH & LH)	
7. Fuel tank protector (RH & LH)	
8. Front side member extension rear (RH & LH)	B
9. Lower dash crossmember assembly	
10. Lower dash assembly	C
11. Lower dash crossmember	
12. Side member center assembly (RH & LH)	
13. Steering hole cover	D
14. Front strut housing assembly (RH & LH)	
15. Engine mounting bracket	
16. Front floor assembly (RH & LH)	E
17. Center floor assembly	
18. Front side member assembly (RH & LH)	
19. Front side member (RH & LH)	F
20. Front suspension member mounting bracket assembly (RH & LH)	
21. Front side member connector (RH & LH)	G
22. Outside front suspension member mounting bracket (RH & LH)	
23. Front side member closing plate (RH & LH)	
24. Hoodledge connector (RH & LH)	H
25. Hoodledge upper (RH & LH)	
26. Hoodledge front reinforcement (RH & LH)	
27. Hoodledge rear reinforcement (RH & LH)	BL
28. Dash side panel (RH & LH)	
29. Dash side assembly (RH & LH)	
30. Front side member outrigger (RH & LH)	J
31. Sill inner assembly (RH & LH)	
32. Sill inner extension (RH & LH)	K
33. Rear side member (RH & LH)	
34. Rear side member extension (RH & LH)	
35. Rear side member assembly (RH & LH)	L
36. Inner rear wheel housing assembly LH	
37. Rear front extension (RH & LH)	
38. Rear seat crossmember	M
39. Rear floor front extension	
40. Rear floor front	
41. Rear seat back side support (RH & LH)	N
42. Rear seat belt anchor inner reinforcements	
43. Rear center crossmember	O
44. Rear floor side assembly (RH & LH)	
45. Rear floor rear	
46. Inner rear wheel housing assembly RH	P

# BODY REPAIR

## < SERVICE INFORMATION > BODY COMPONENT PARTS

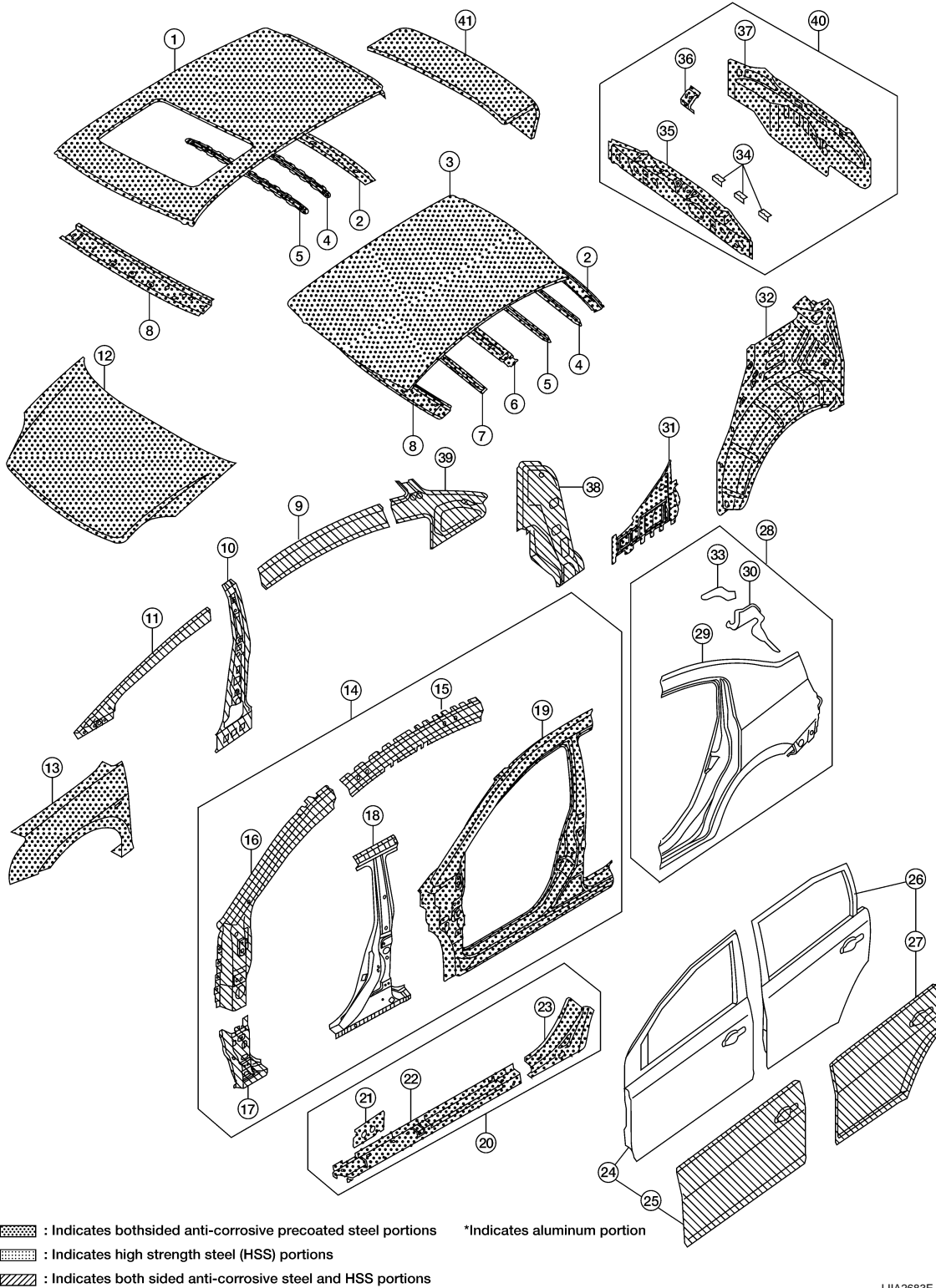

LIA2683E

1. Sunroof panel assembly
2. Rear roof rail assembly
3. Standard roof panel assembly
4. 4th roof bow assembly
5. 3rd roof bow assembly

# BODY REPAIR

## < SERVICE INFORMATION >

---

6. 2nd roof bow assembly	A
7. 1st roof bow assembly	
8. Front roof rail assembly	
9. Inner side roof rail (RH & LH)	
10. Center pillar inner reinforcement (RH & LH)	B
11. Front pillar inner (RH & LH)	
12. Hood assembly	C
13. Front fender assembly (RH & LH)	
14. Front body side assembly (RH & LH)	
15. Outer roof side reinforcement (RH & LH)	D
16. Front pillar upper reinforcement (RH & LH)	
17. Front pillar lower reinforcement (RH & LH)	
18. Center pillar reinforcement (RH & LH)	E
19. Front body side outer (RH & LH)	
20. Sill reinforcement assembly (RH & LH)	F
21. Front sill reinforcement (RH & LH)	
22. Sill reinforcement (RH & LH)	
23. Rear sill reinforcement (RH & LH)	G
24. Front door assembly (RH & LH)	
25. Front door outer panel (RH & LH)	
26. Rear door assembly (RH & LH)	H
27. Rear door outer panel (RH & LH)	
28. Rear body side assembly (RH & LH)	
29. Rear body side outer (RH & LH)	BL
30. Rear combination lamp base (RH & LH)	
31. Rear wheel housing outer extension (RH & LH)	J
32. Outer rear wheel housing (RH & LH)	
33. Trunk hinge reinforcement (RH & LH)	
34. Rear fascia brackets	K
35. Rear panel upper reinforcement	
36. Jack mounting bracket	
37. Rear panel	L
38. Rear pillar reinforcement (RH & LH)	
39. Inner rear pillar reinforcement (RH & LH)	
40. Rear panel assembly	M
41. Trunk lid assembly	

## Corrosion Protection

INFOID:000000004407825

### DESCRIPTION

To provide improved corrosion prevention, the following anti-corrosive measures have been implemented in NISSAN production plants. When repairing or replacing body panels, it is necessary to use the same anti-corrosive measures.

ANTI-CORROSIVE PRECOATED STEEL (GALVANNEALED STEEL)

# BODY REPAIR

## < SERVICE INFORMATION >

To improve reparability and corrosion resistance, a new type of anti-corrosive pre-coated steel sheet has been adopted replacing conventional zinc-coated steel sheet.

Galvannealed steel is electroplated and heated to form Zinc-iron alloy, which provides excellent and long term corrosion resistance with cationic electrodeposition primer.

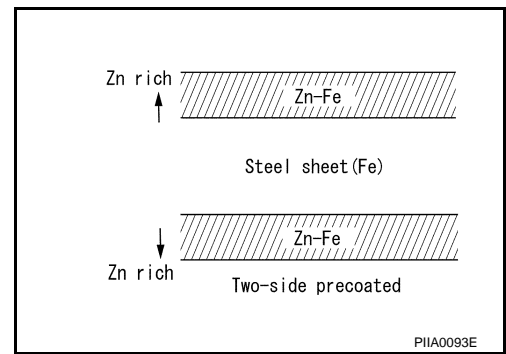

Nissan Genuine Service Parts are fabricated from galvannealed steel. Therefore, it is recommended that GENUINE NISSAN PARTS or equivalent be used for panel replacement to maintain the anti-corrosive performance built into the vehicle at the factory.

### PHOSPHATE COATING TREATMENT AND CATIONIC ELECTRODEPOSITION PRIMER

A phosphate coating treatment and a cationic electrode position primer, which provide excellent corrosion protection, are employed on all body components.

#### **CAUTION:**

**Confine paint removal during welding operations to an absolute minimum.**

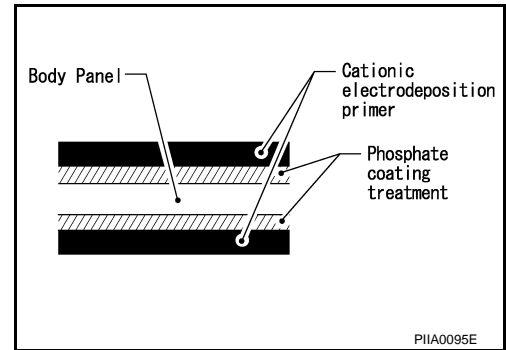

Nissan Genuine Service Parts are also treated in the same manner. Therefore, it is recommended that GENUINE NISSAN PARTS or equivalent be used for panel replacement to maintain anti-corrosive performance built into the vehicle at the factory.

### ANTI-CORROSIVE WAX

To improve corrosion resistance, anti-corrosive wax is applied inside the body sill and inside other closed sections. Accordingly, when replacing these parts, be sure to apply anti-corrosive wax to the appropriate areas of





# BODY REPAIR

## < SERVICE INFORMATION >

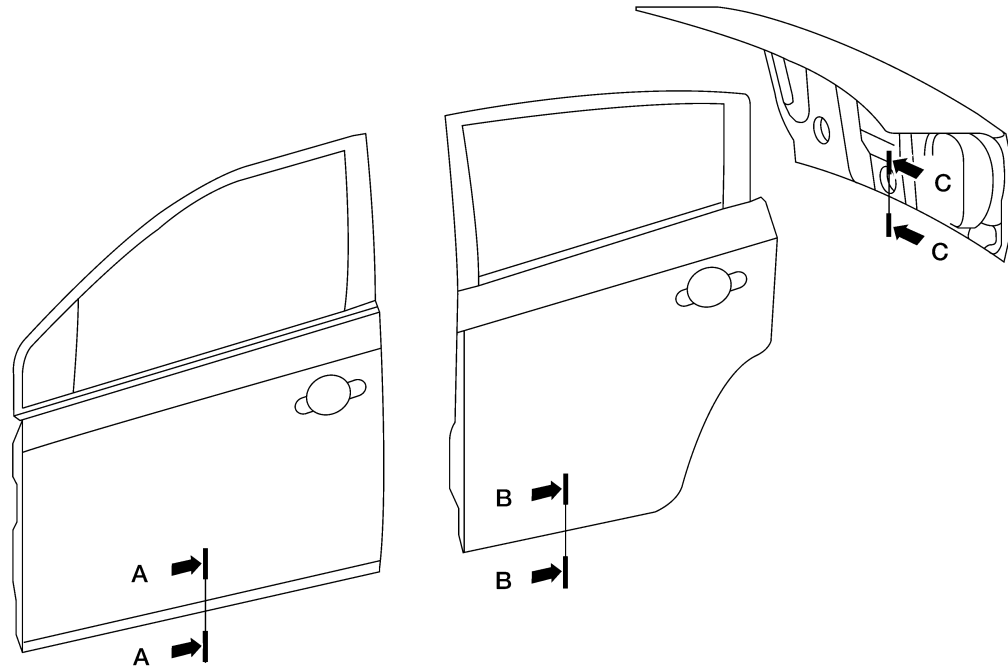
the new parts. Select an excellent anti-corrosive wax which will penetrate after application and has a long shelf life.



 : indicates outside body sealant  
 : Indicates anti-corrosive wax coated portions

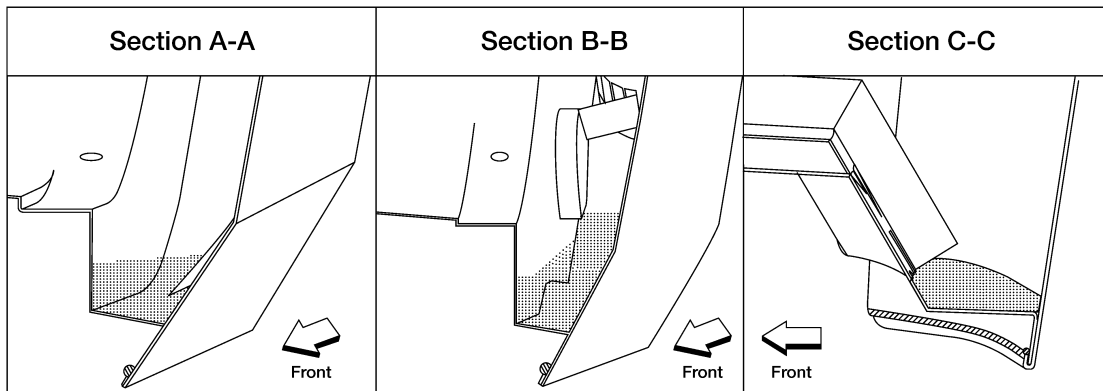

LIA2684E

## UNDERCOATING

The underside of the floor and wheelhouse are undercoated to prevent rust, vibration, noise and stone chipping. Therefore, when such a panel is replaced or repaired, apply undercoating to that part. Use an undercoating which is rust preventive, soundproof, vibration-proof, shock-resistant, adhesive, and durable.

### Precautions in undercoating

1. Do not apply undercoating to any place unless specified (such as the areas above the muffler and three way catalyst which are subjected to heat).
2. Do not undercoat the exhaust pipe or other parts which become hot.

# BODY REPAIR

## < SERVICE INFORMATION >

3. Do not undercoat rotating parts.

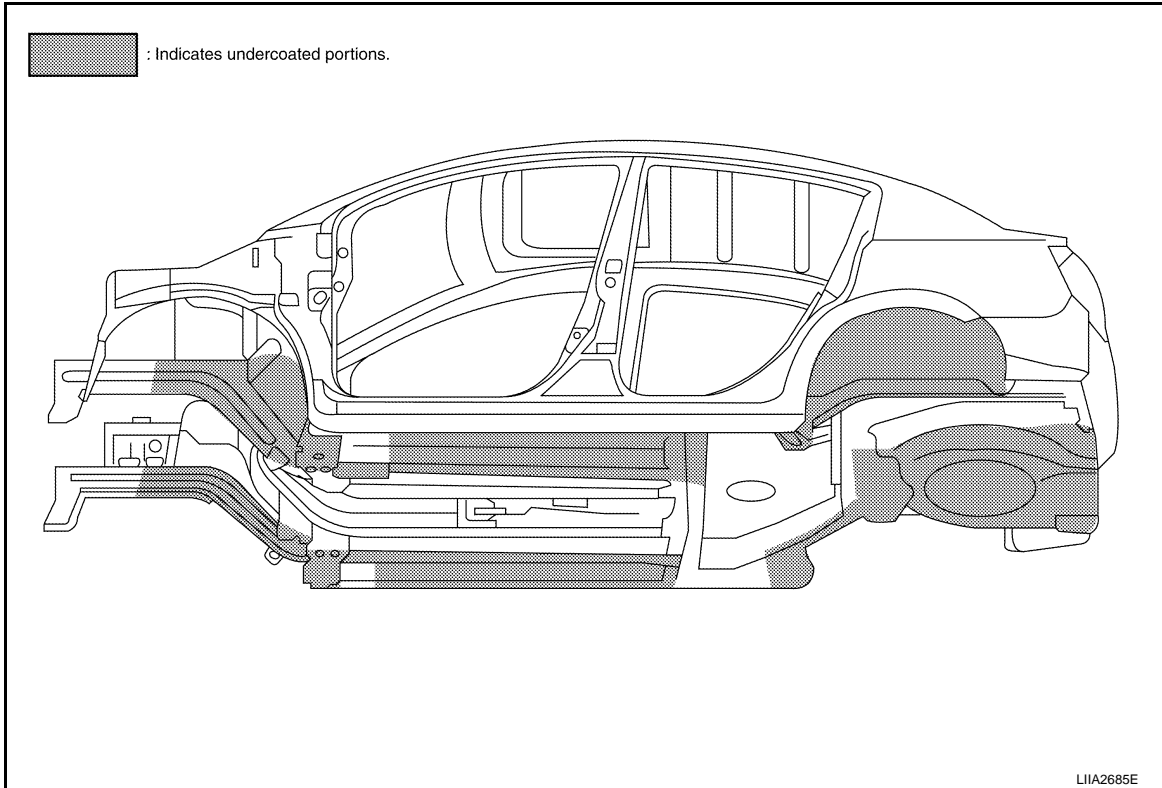

### Body Sealing

INFOID:000000004407826

### DESCRIPTION

# BODY REPAIR

## < SERVICE INFORMATION >

The following figure shows the areas which are sealed at the factory. Sealant which has been applied to these areas should be smooth and free from cuts or gaps. Care should be taken not to apply an excess amount of sealant and not to allow other unaffected parts to come into contact with the sealant.

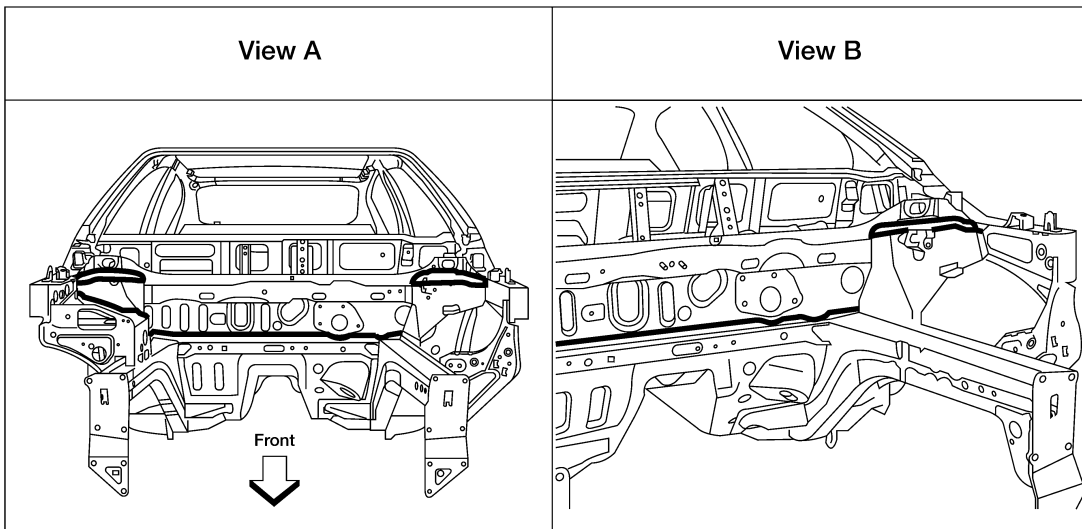
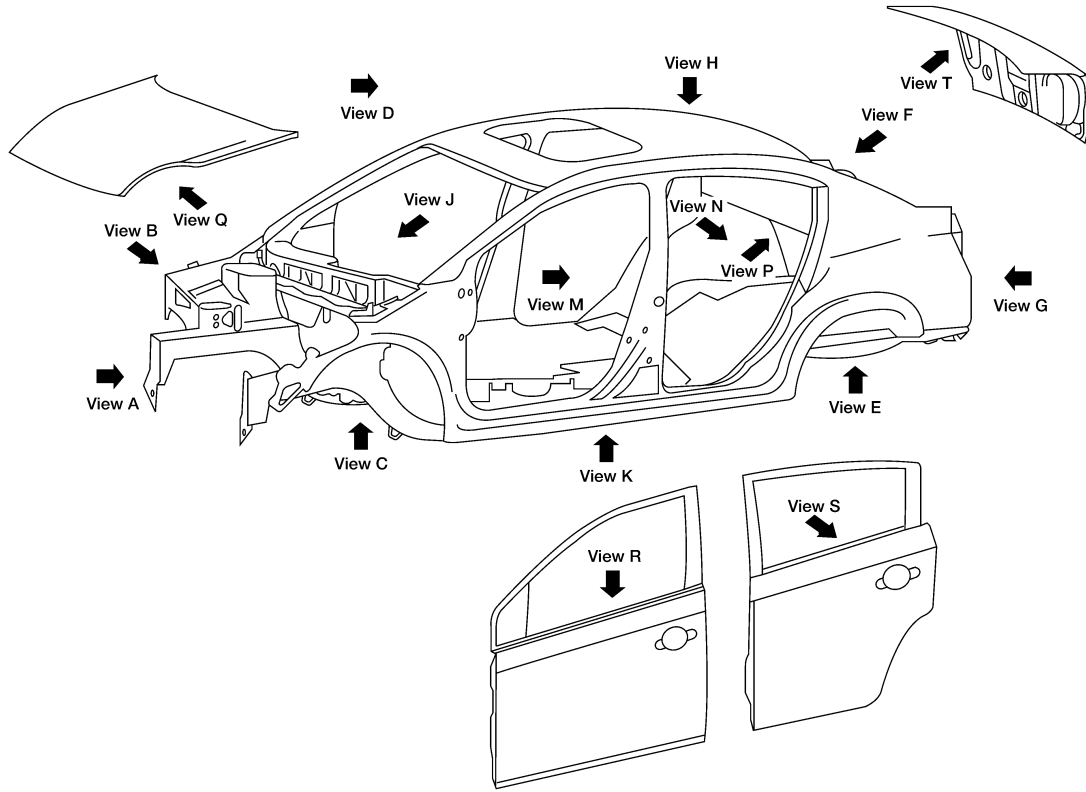

LIA2686E

# BODY REPAIR

< SERVICE INFORMATION >

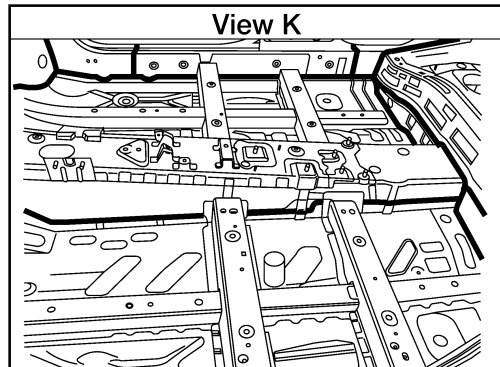
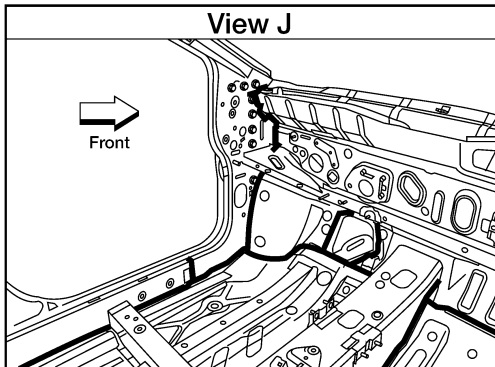
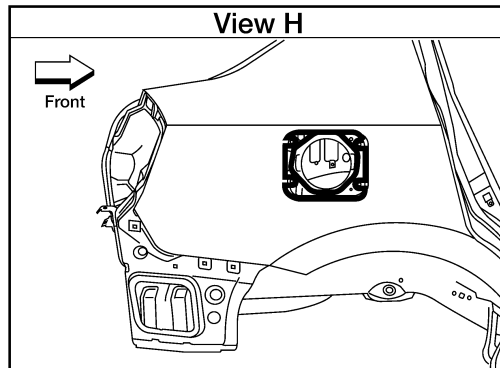
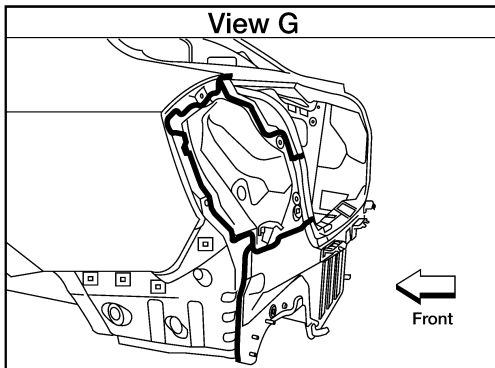
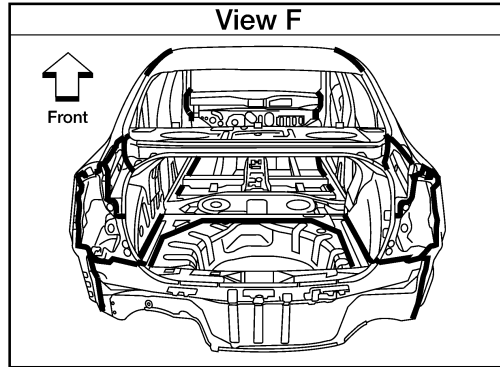
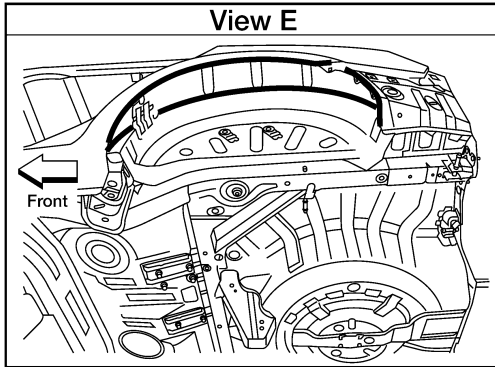
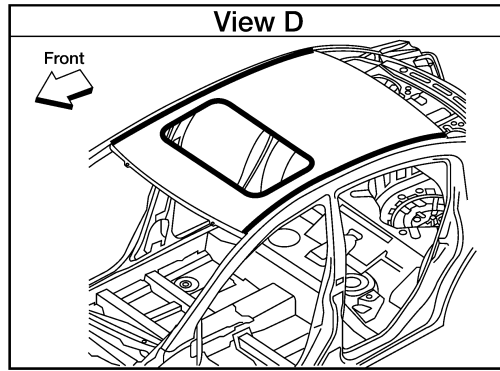
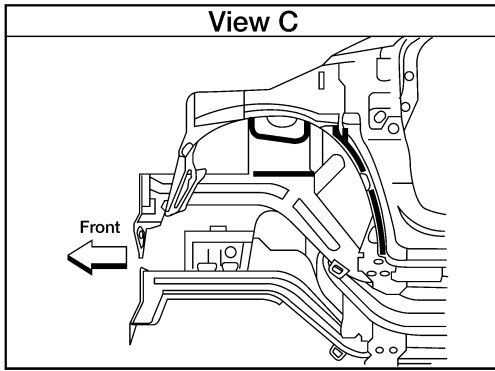

LIA2687E

# BODY REPAIR

< SERVICE INFORMATION >

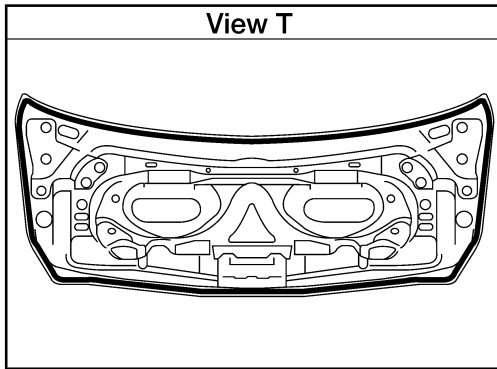
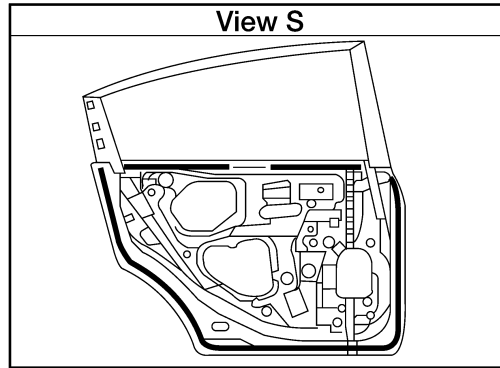
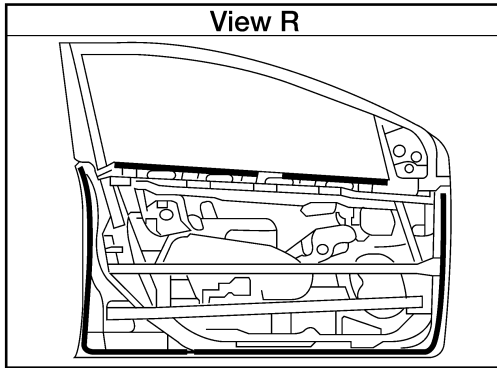
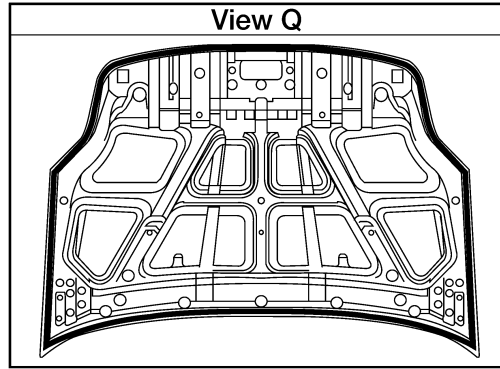
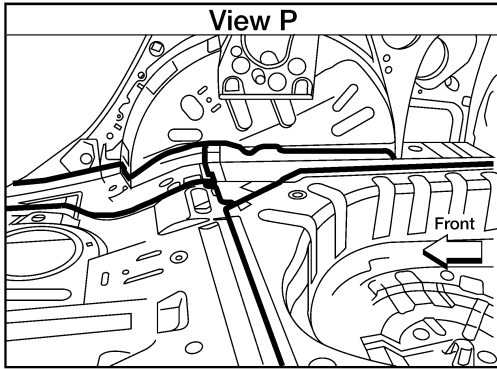
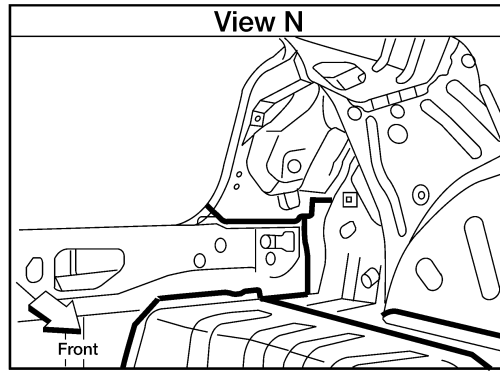
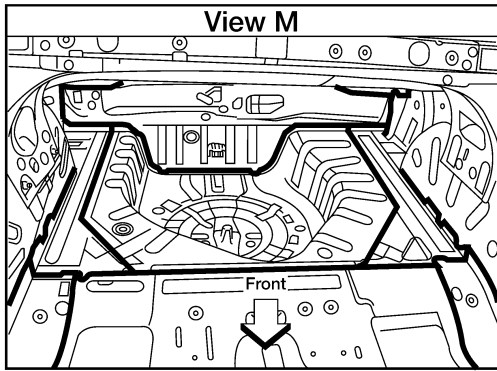

A  
B  
C  
D  
E  
F  
G  
H  
BL  
J  
K  
L  
M  
N  
O  
P

LIA2688E

# BODY REPAIR

< SERVICE INFORMATION >

## Body Construction

INFOID:000000004407827

### BODY CONSTRUCTION

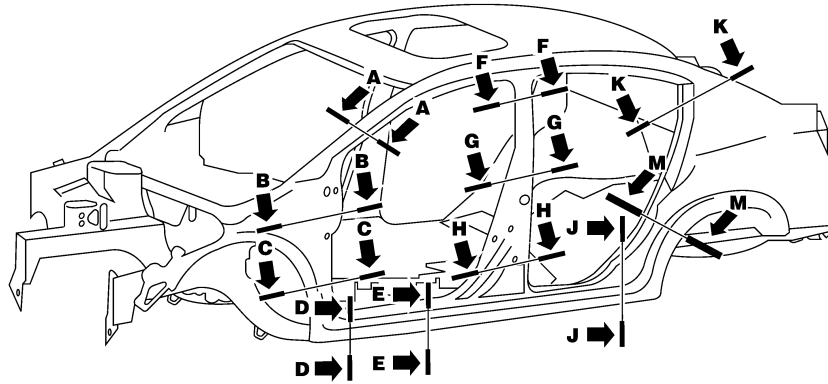

Section A - A	Section B - B	Section C - C	Section D - D
Section E - E	Section F - F	Section G - G	Section H - H
Section J - J	Section K - K	Section M - M	

LIA2689E

### Body Alignment

INFOID:000000004407828

### BODY CENTER MARKS

# BODY REPAIR

## < SERVICE INFORMATION >

A mark has been placed on each part of the body to indicate the vehicle center. When repairing parts damaged by an accident which might affect the vehicle frame (members, pillars, etc.), more accurate and effective repair will be possible by using these marks together with body alignment specifications.

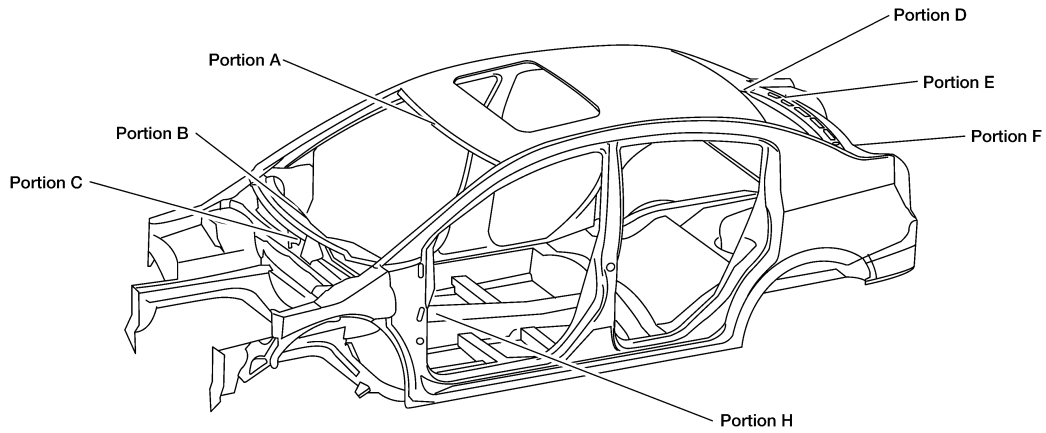

Portion A	Portion B	Portion C
<p>(A) : Roof flange end of center positioning mark</p> <p>Front</p>	<p>(B) : Bottom center of windshield opening</p>	<p>(C) : Cowl top flange end of center positioning mark</p>
Portion D	Portion E	Portion F
<p>(D) : Roof flange end of center positioning mark</p> <p>Front</p>	<p>(E) : Rear waist panel flange end</p>	<p>(F) : Rear bumper area</p> <p>Front</p>
Portion H		
<p>Hole (12dia.)</p> <p>Front</p>		

PANEL PARTS MATCHING MARKS

L1IA2690E

# BODY REPAIR

## < SERVICE INFORMATION >

A mark has been placed on each body panel to indicate the parts matching positions. When repairing parts damaged by an accident which might affect the vehicle structure (members, pillars, etc.), more accurate and effective repair will be possible by using these marks together with body alignment specifications.

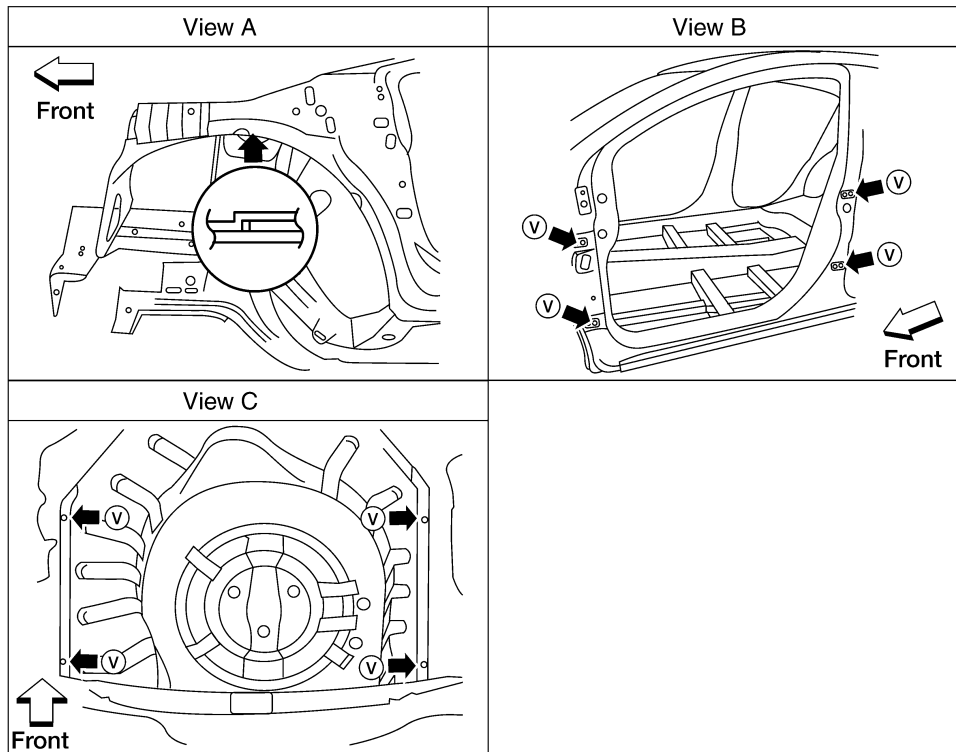
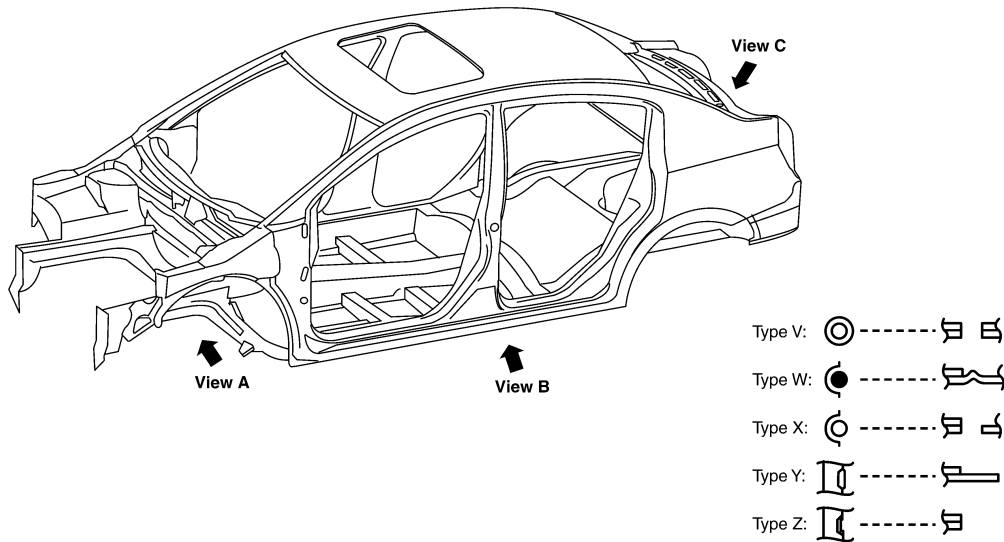

L1A2691E

### DESCRIPTION

- All dimensions indicated in the figures are actual.
- When using a tracking gauge, adjust both pointers to equal length. Then check the pointers and gauge itself to make sure there is no free play.
- When a measuring tape is used, check to be sure there is no elongation, twisting or bending.
- Measurements should be taken at the center of the mounting holes.
- An asterisk (\*) following the value at the measuring point indicates that the measuring point on the other side is symmetrically the same value.
- The coordinates of the measurement points are the distances measured from the standard line of "X", "Y" and "Z".



# BODY REPAIR

< SERVICE INFORMATION >

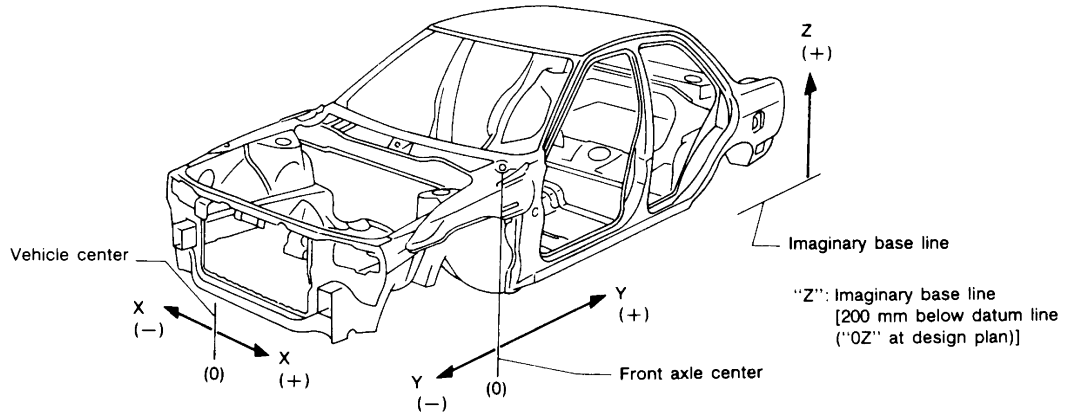

PIA0104E

## ENGINE COMPARTMENT

Measurement

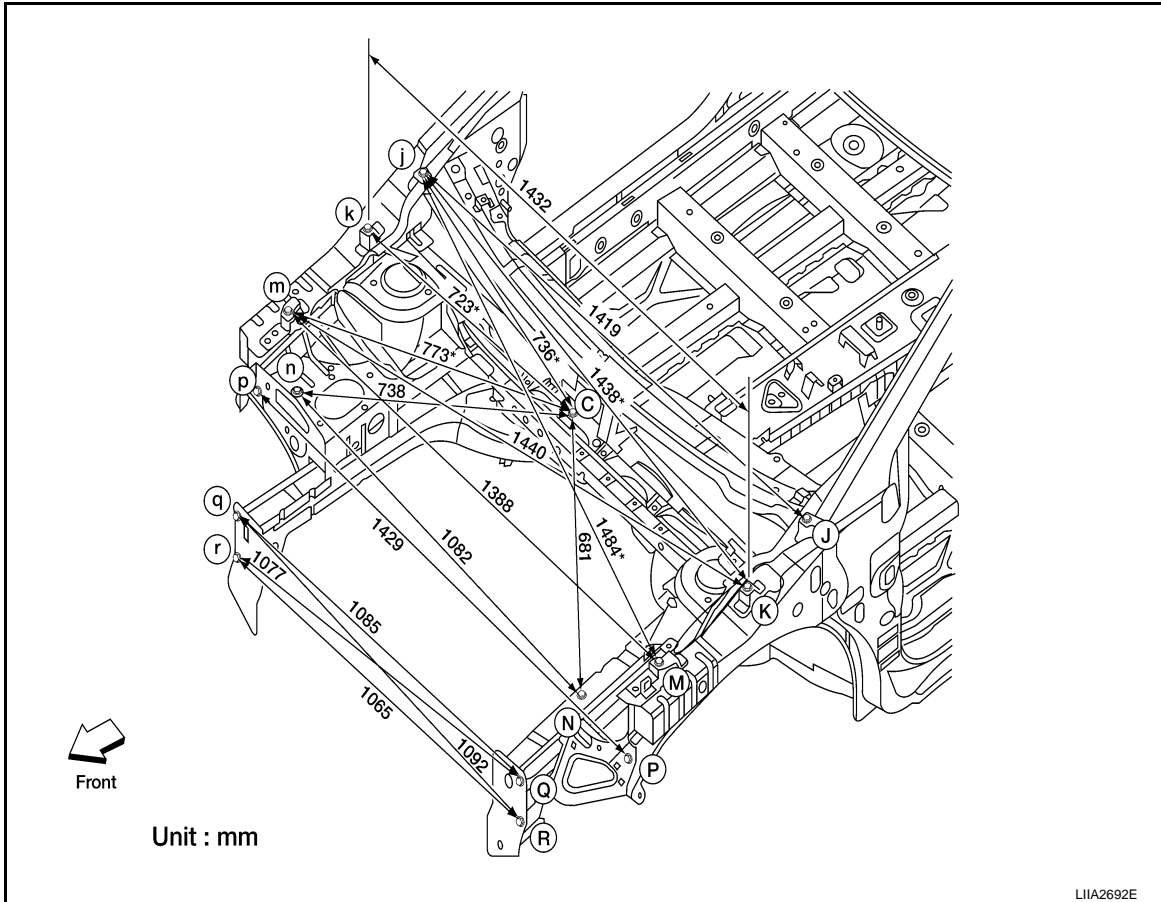

# BODY REPAIR

## < SERVICE INFORMATION >

### Measurement Points

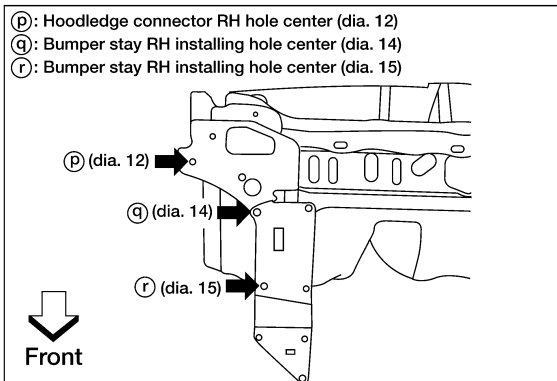
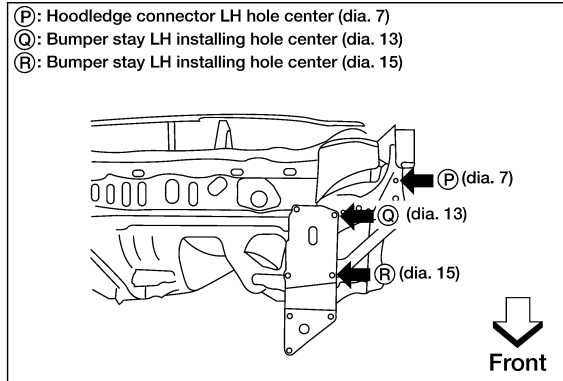
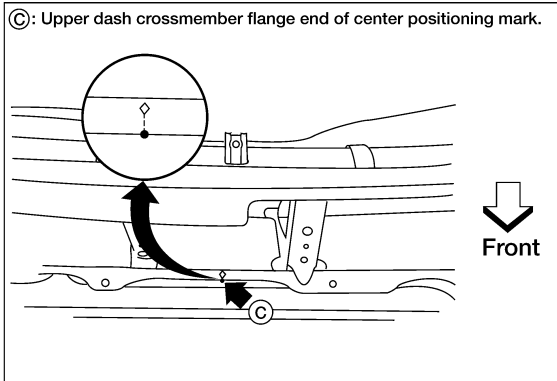
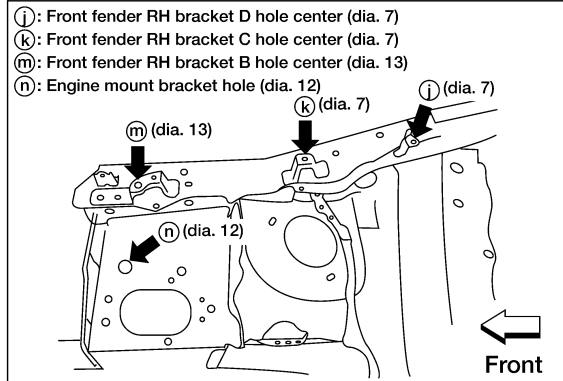
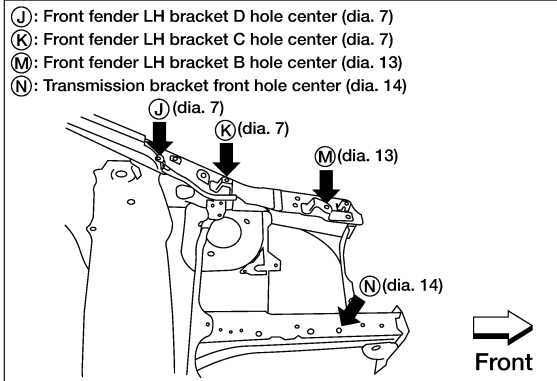

LIA2693E

## UNDERBODY

# BODY REPAIR

## < SERVICE INFORMATION >

### Measurement

Unit: mm

Figures marked with a (\*) indicate symmetrically identical dimensions on both right and left hand sides of the vehicle.

As viewed from underside.

All dimensions indicated in this figure are actual.

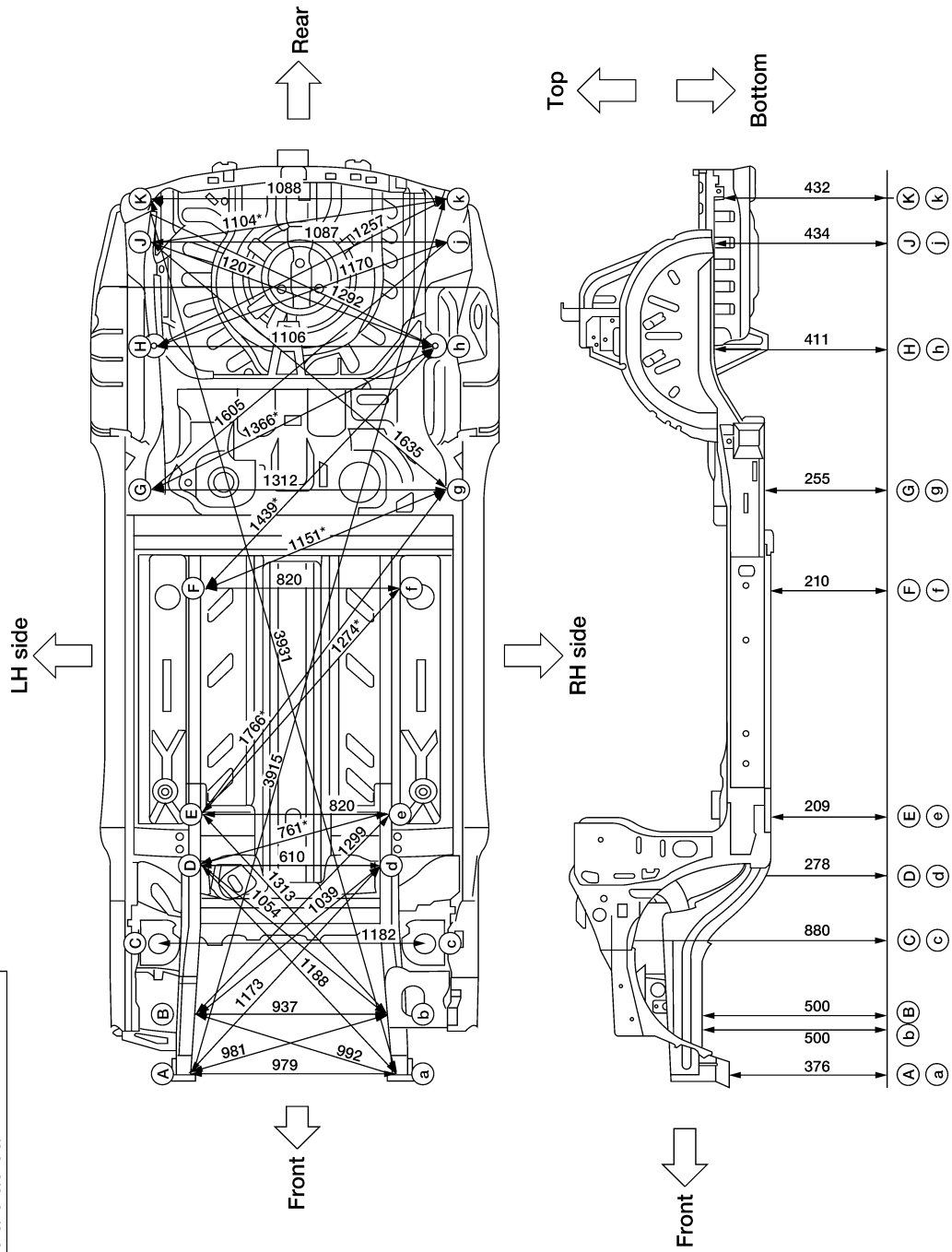

A  
B  
C  
D  
E  
F  
G  
H  
BL  
J  
K  
L  
M  
N  
O  
P

AWIIA1268GB

# BODY REPAIR

## < SERVICE INFORMATION >

### Measurement Points

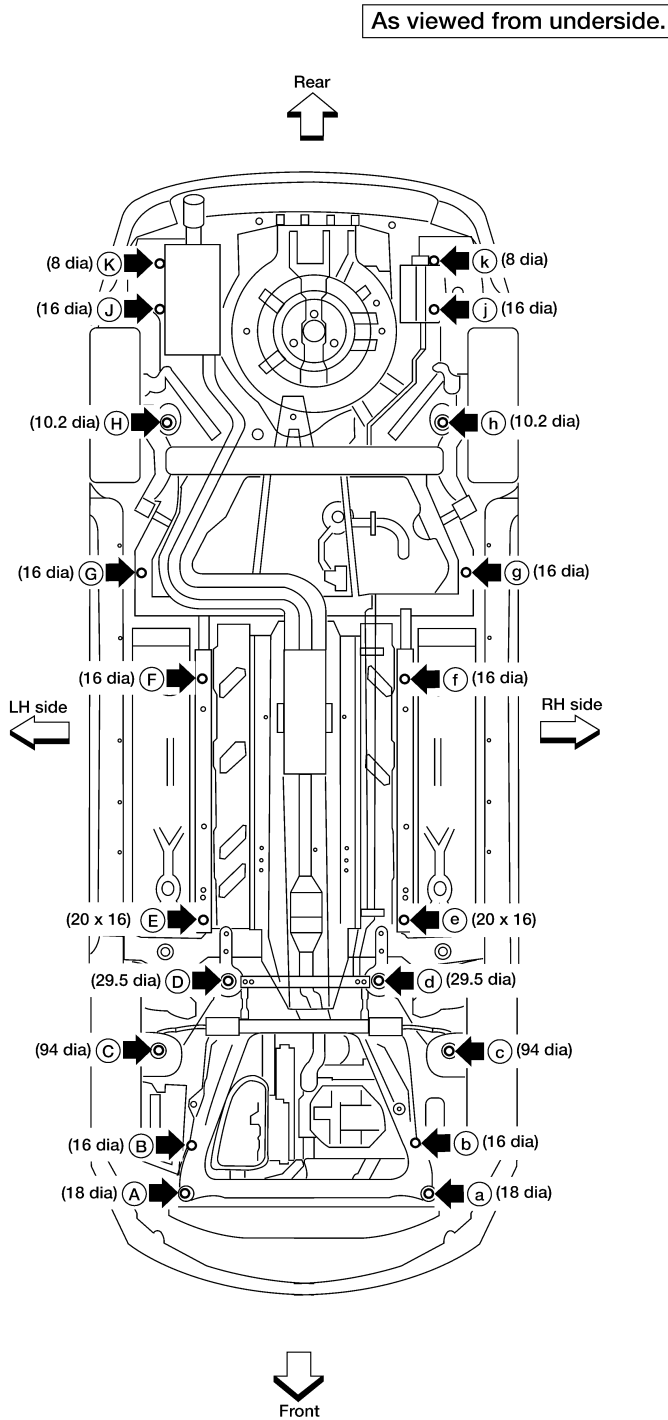

Coordinates:

(A)	(a)
X : -478	X : 501
Y : -566.6	Y : 566.6
Z : 376	Z : 376
(B)	(b)
X : -462.4	X : -474.4
Y : -364	Y : -372
Z : 500	Z : 500
(D), (d)	
X : ±305	
Y : 301	
Z : 278	
(E)	(e)
X : -410	X : 410
Y : -547	Y : 547
Z : 209	Z : 209
(F), (f)	
X : ±410	
Y : 1522.5	
Z : 210	
(G), (g)	
X : ±656	
Y : 1953	
Z : 255	
(H), (h)	
X : ±553	
Y : 2568.2	
Z : 411	
(J)	(j)
X : 563.5	X : 523.5
Y : 3027	Y : 3027
Z : 434	Z : 434
(K)	(k)
X : 564	X : 523.5
Y : 3217.3	Y : 3217.3
Z : 432	Z : 432

Strut tower centers

Coordinates:

(C), (c) Front
X : 13.7
Y : ±591.1
Z : 679.7

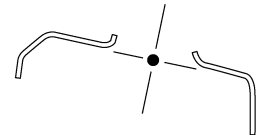

Unit: mm

AWIIA1269GB

PASSENGER COMPARTMENT

# BODY REPAIR

## < SERVICE INFORMATION >

### Measurement

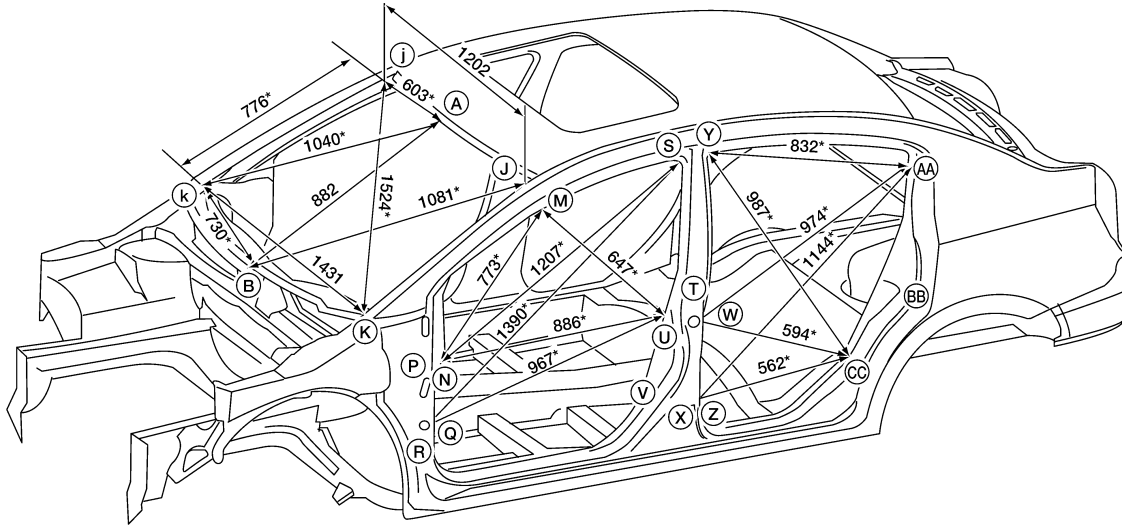

Point	Dimension	Point	Dimension	Point	Dimension	Point	Dimension
AA-aa	1,292	CC-cc	1,460	H-Q	778*	R-V	978*
AA-CC	767*	CC-w	1,566*	H-U	1,063*	R-X	1,095*
AA-cc	1573*	CC-z	1,562*	M-m	1,254	T-BB	810*
AA-w	1,657*	hh-aa	1,039*	N-n	1,446	T-X	339*
AA-z	1,786*	hh-cc	620*	P-R	1,118*	U-n	1,695*
A-D	1685	hh-D	1,131	P-T	1,118*	U-q	1,740*
A-E	2,212	H-hh	1,213*	P-V	996*	U-u	1,444
A-H	1,019	hh-w	752*	P-X	1,131*	W-w	1,438
B-D	2504	hh-z	703*	Q-n	1,473*	X-BB	853*
B-E	2986	H-M	1,171*	Q-q	1,450	Z-z	1,456
B-H	883	H-N	848*	R-T	1,179*		

Unit : mm

LIA2696E

A  
B  
C  
D  
E  
F  
G  
H  
BL  
J  
K  
L  
M  
N  
O  
P

# BODY REPAIR

## < SERVICE INFORMATION >

### Measurement Points

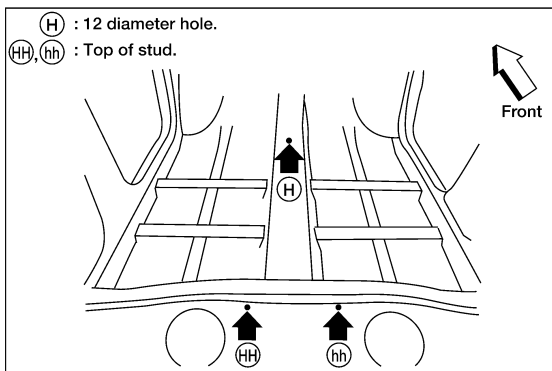
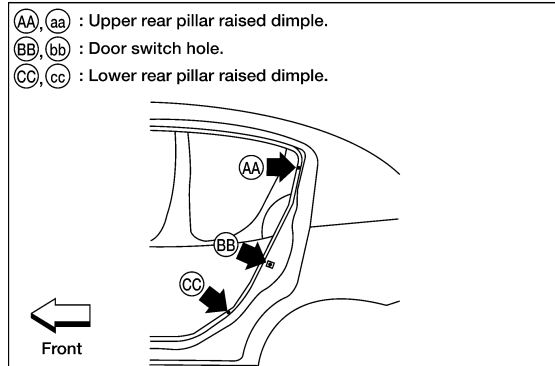
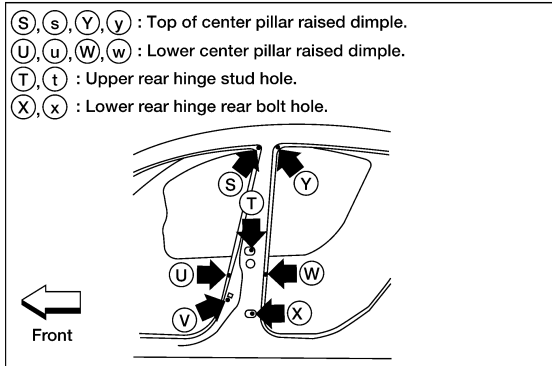
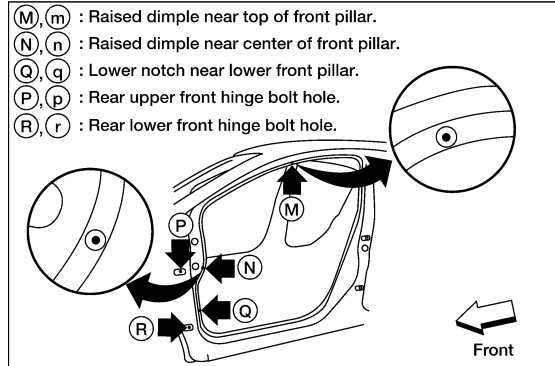
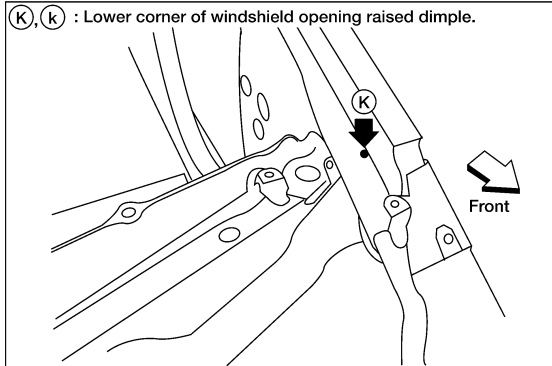
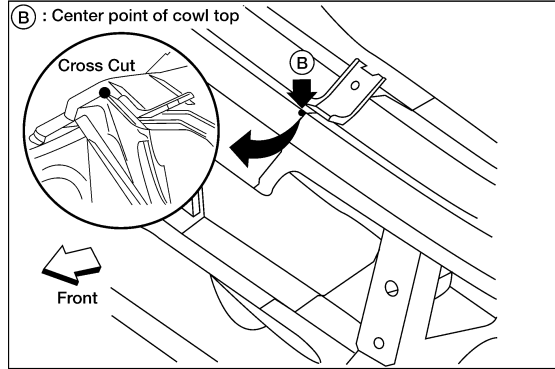
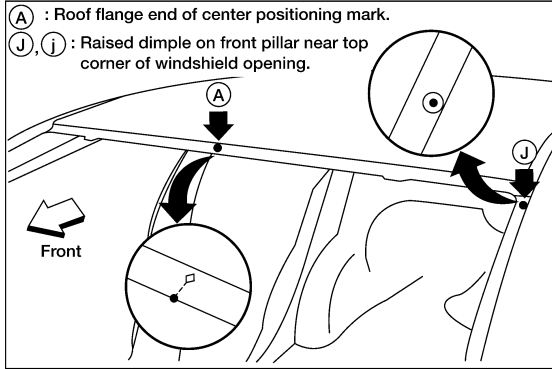

LIA2697E

## REAR BODY

# BODY REPAIR

## < SERVICE INFORMATION >

### Measurement

Figures marked with a (\*) indicate symmetrically identical dimensions on both right and left sides of the vehicle.

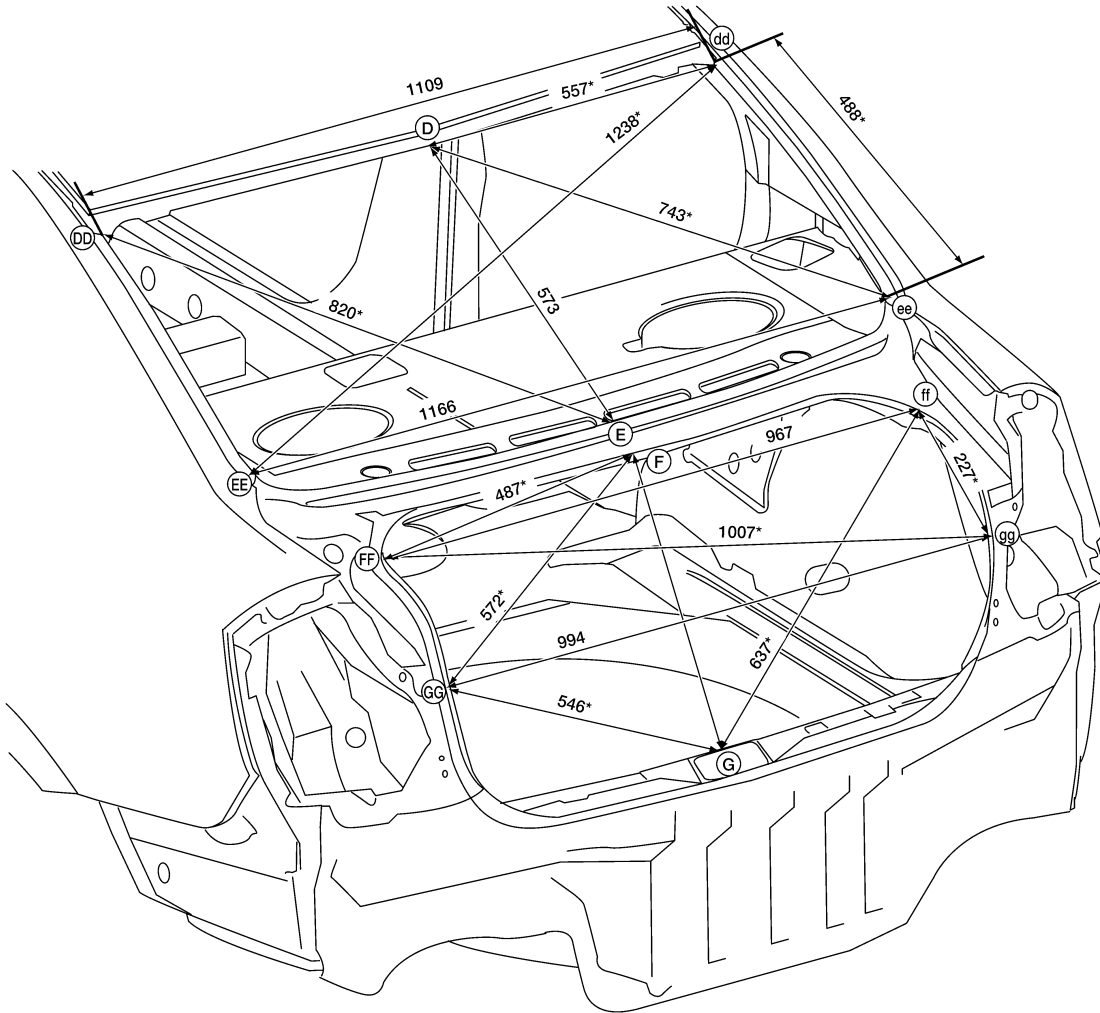

Unit: mm

LIA2698E

A  
B  
C  
D  
E  
F  
G  
H  
BL  
J  
K  
L  
M  
N  
O  
P

# BODY REPAIR

## < SERVICE INFORMATION >

### Measurement Points

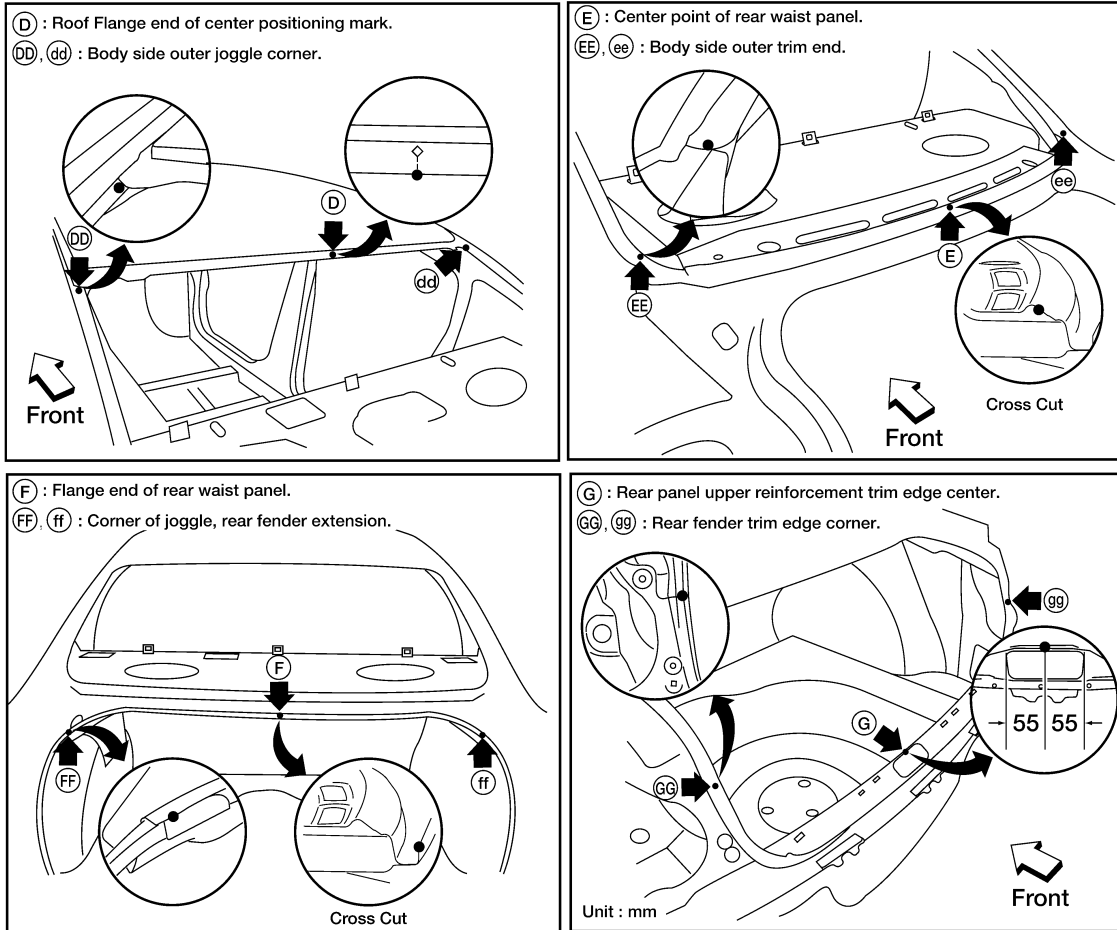

LIA2699E

INFOID:000000004407829

Handling Precaution for Plastics

HANDLING PRECAUTIONS FOR PLASTICS



# BODY REPAIR

## < SERVICE INFORMATION >

Abbreviation	Material name	Heat resisting temperature °C (°F)	Resistance to gasoline and solvents	Other cautions
PE	Polyethylene	60 (140)	Gasoline and most solvents are harmless if applied for a very short time (wipe up quickly).	Flammable
PVC	Polyvinyl Chloride	80 (176)	Same as above.	Poison gas is emitted when burned.
EPM/EPDM	Ethylene Propylene (Diene) rubber	80 (176)	Same as above.	Flammable
TPO/TPR	Thermoplastic Olefine/ Thermoplastic Rubber	80 (176)	Same as above.	Flammable
PP	Polypropylene	90 (194)	Same as above.	Flammable, avoid battery acid.
UP	Polyester thermoset	90 (194)	Same as above.	Flammable
PS	Polystyrene	80 (176)	Avoid solvents.	Flammable
ABS	Acrylonitrile Butadiene Styrene resin	80 (176)	Avoid gasoline and solvents.	
AES	Acrylonitrile Ethylene Styrene	80 (176)	Same as above.	
PMMA	Polymethyl Methacrylate	85 (185)	Same as above.	
AAS	Acrylonitrile Acrylic Styrene	85 (185)	Same as above.	
AS	Acrylonitrile Styrene	85 (185)	Same as above.	
EVA	Polyvinyl Ethyl Acetate	90 (194)	Same as above.	
ASA	Acrylonitrile Styrene Acrylate	100 (222)	Same as above.	Flammable
PPO/PPE	Polyphenylene Oxide/ Polyphenylene Ether	110 (230)	Same as above.	
PC	Polycarbonate	120 (248)	Same as above.	
PAR	Polyacrylate	180 (356)	Same as above.	
L-LDPE	Linear Low Density PE	45 (100)	Gasoline and most solvents are harmless.	Flammable
PUR	Polyurethane	90 (194)	Same as above.	
TPU	Thermoplastic Urethane	110 (230)	Same as above.	
PPC	Polypropylene Composite	115 (239)	Same as above.	Flammable
POM	Polyacetal	120 (248)	Same as above.	Avoid battery acid.
PBT+PC	Polybutylene Terephthalate+Polycarbonate	120 (248)	Same as above.	Flammable
PA	Polyamide (Nylon)	140 (284)	Same as above.	Avoid immersing in water.
PBT	Polybutylene Terephthalate	140 (284)	Same as above.	
FRP	Fiber Reinforced Plastics	170 (338)	Same as above.	Avoid battery acid.
PET	Polyethylene Terephthalate	180 (356)	Same as above.	
PEI	Polyetherimide	200 (392)	Same as above.	

- When repairing and painting a portion of the body adjacent to plastic parts, consider their characteristics (influence of heat and solvent) and remove them if necessary or take suitable measures to protect them.
- Plastic parts should be repaired and painted using methods suiting the materials' characteristics.

# BODY REPAIR

< SERVICE INFORMATION >

## LOCATION OF PLASTIC PARTS

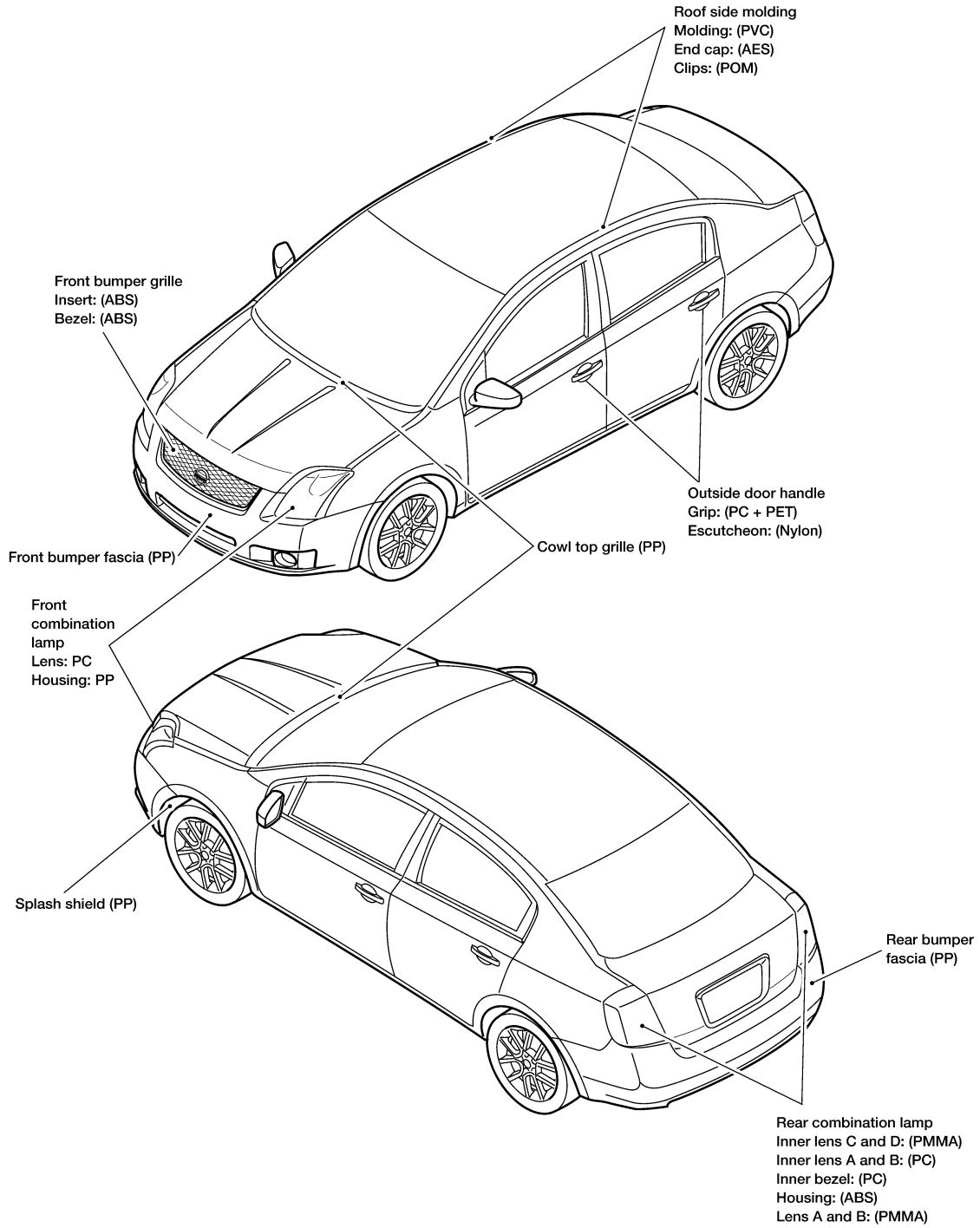

LIA2700E

# BODY REPAIR

< SERVICE INFORMATION >

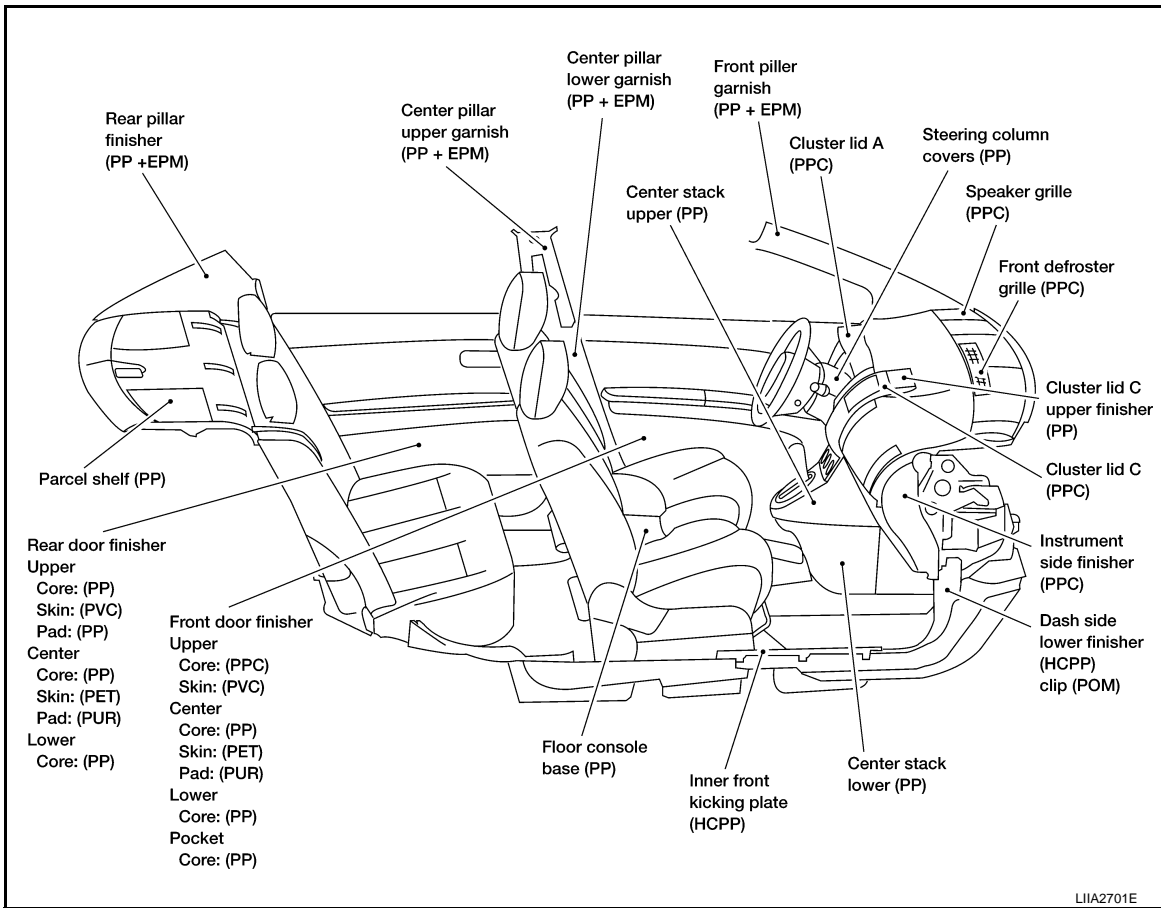

## Precaution in Repairing High Strength Steel

INFOID:000000004407830

High strength steel is used for body panels in order to reduce vehicle weight. Accordingly, precautions in repairing automotive bodies made of high strength steel are described below:

### HIGH STRENGTH STEEL (HSS) USED IN NISSAN VEHICLES

Tensile strength	Nissan/Infiniti designation	Major applicable parts
373 N/mm <sup>2</sup> (38kg/mm <sup>2</sup> ,54klb/sq in)	SP130	<ul style="list-style-type: none"> <li>• Front &amp; rear side member assembly</li> <li>• Front side member closing plate assembly</li> <li>• Front strut housing</li> <li>• Lower dash</li> <li>• Rear seat crossmember</li> <li>• Other reinforcements</li> </ul>
785-1350 N/mm <sup>2</sup> (80-138kg/mm <sup>2</sup> , 114-196klb/sq in)	SP150	<ul style="list-style-type: none"> <li>• Center pillar reinforcement (Component part)</li> <li>• Outer roof side rail reinforcement (Component part)</li> </ul>

SP130 is the most commonly used HSS.

SP150 HSS is used only on parts that require much more strength.

Read the Following Precautions When Repairing HSS:

1. Additional points to consider

# BODY REPAIR

## < SERVICE INFORMATION >

- The repair of reinforcements (such as side members) by heating is not recommended since it may weaken the component. When heating is unavoidable, do not heat HSS parts above 550°C (1,022°F). Verify heating temperature with a thermometer. (Crayon-type and other similar type thermometer are appropriate.)

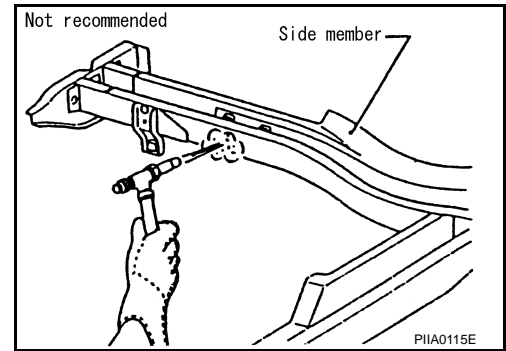

- When straightening body panels, use caution in pulling any HSS panel. Because HSS is very strong, pulling may cause deformation in adjacent portions of the body. In this case, increase the number of measuring points, and carefully pull the HSS panel.

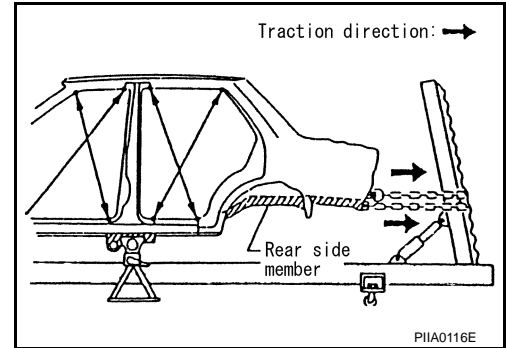

- When cutting HSS panels, avoid gas (torch) cutting if possible. Instead, use a saw to avoid weakening surrounding areas due to heat. If gas (torch) cutting is unavoidable, allow a minimum margin of 50 mm (1.97in).

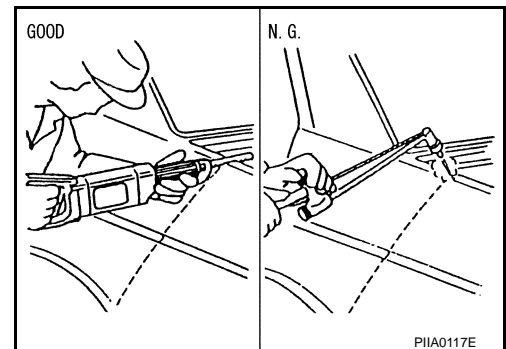

- When welding HSS panels, use spot welding whenever possible in order to minimize weakening surrounding areas due to heat. If spot welding is impossible, use M.I.G. welding. Do not use gas (torch) welding because it is inferior in welding strength.

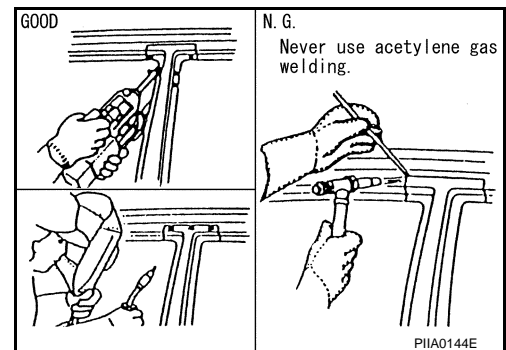

# BODY REPAIR

## < SERVICE INFORMATION >

- The spot weld on HSS panels is harder than that of an ordinary steel panel. Therefore, when cutting spot welds on a HSS panel, use a low speed high torque drill (1,000 to 1,200 rpm) to increase drill bit durability and facilitate the operation.

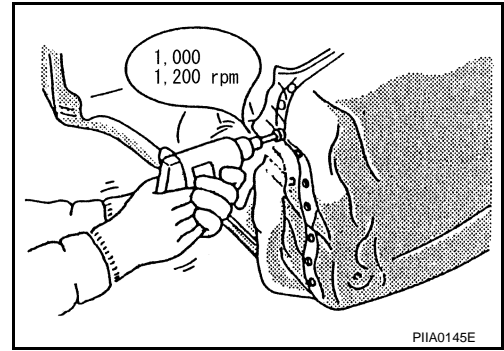

### 2. Precautions in spot welding HSS

This work should be performed under standard working conditions. Always note the following when spot welding HSS:

- The electrode tip diameter must be sized properly according to the metal thickness.

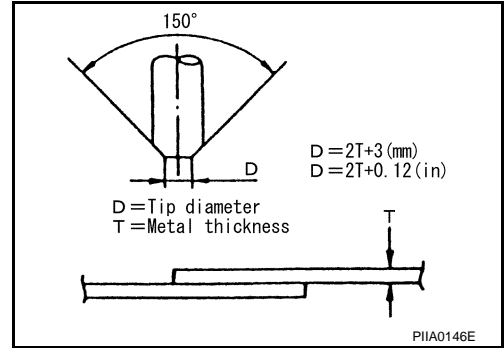

- The panel surfaces must fit flush to each other, leaving no gaps.

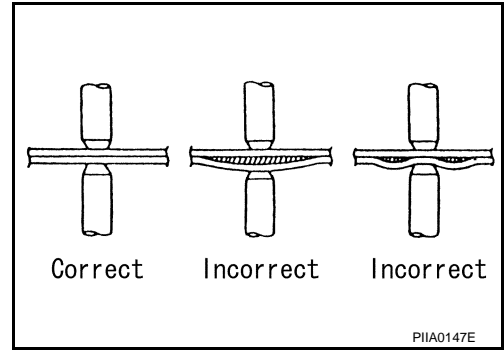

- Follow the specifications for the proper welding pitch.

Unit: mm

Thickness (t)	Minimum pitch (ℓ)
0.6 (0.024)	10 (0.39) or over
0.8 (0.031)	12 (0.47) or over
1.0 (0.039)	18 (0.71) or over
1.2 (0.047)	20 (0.79) or over
1.6 (0.063)	27 (1.06) or over
1.8 (0.071)	31 (1.22) or over

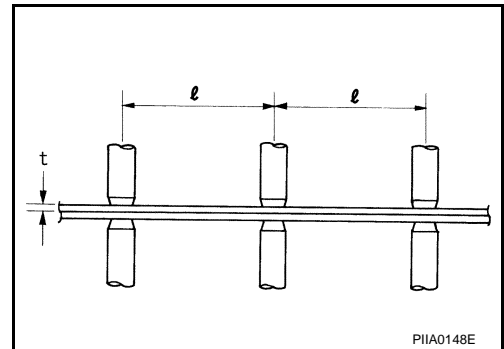

### Rear fender hemming process

- A wheel arch is to be installed and hemmed over left and right outer wheel house.
- In order to hem the wheel arch, it is necessary to repair any damaged or defaced parts around outer wheel house.

#### **CAUTION:**

**Ensure that the area that is to be glued around outer wheelhouse is undamaged or defaced.**

### Procedure of the hemming process

# BODY REPAIR

## < SERVICE INFORMATION >

- Peel off old bonding material on the surface of outer wheelhouse and clean thoroughly.
- Peel off a primer coat in the specified area where new adhesive is to be applied on rear fender (the replacing part).
- Apply new adhesive to both specified areas of outer wheelhouse and rear fender.

**<Adhesive> 3M automix panel bond 8115,  
or any equivalents**

- Attach rear fender to the body of the car, and weld the required part except the hemming part.

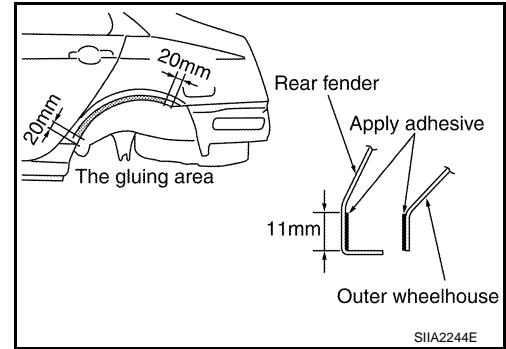

- Bend the welded part starting from the center of the wheel arch gradually with a hammer and a dolly. (Also hem the end of the flange.)
- Hemming with a hammer is conducted to an approximate angle of 80 degrees.

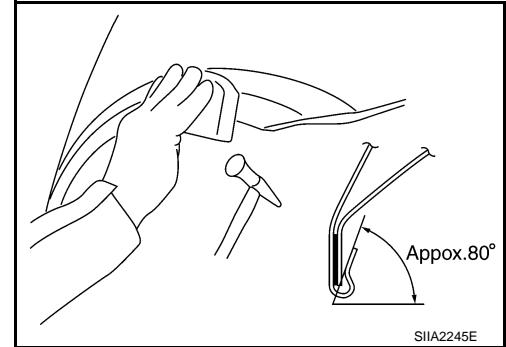

- Starting from the center, hem the wheel arch gradually, using slight back and forth motion with a hemming tool.

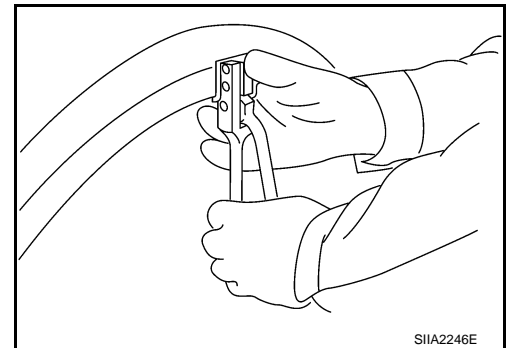

- Seal up the area around the hemmed end of the flange.

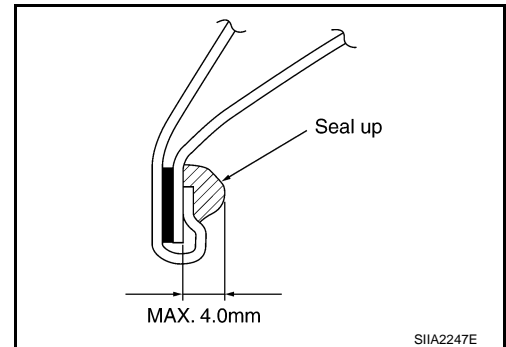

## Foam Repair

INFOID:000000004407831

During factory body assembly, foam insulators are installed in certain body panels and locations around the vehicle. Use the following procedure(s) to replace any factory-installed foam insulators.

### URETHANE FOAM APPLICATIONS

Use commercially available spray foam for sealant (foam material) repair of material used on vehicle. Read instructions on product for fill procedures.

### FILL PROCEDURES

1. Fill procedures after installation of service part.

# BODY REPAIR

## < SERVICE INFORMATION >

- Remove foam material remaining on vehicle side.
- Clean area in which foam was removed.
- Install service part.
- Insert nozzle into hole near fill area and fill foam material or fill in enough to close gap with the service part.

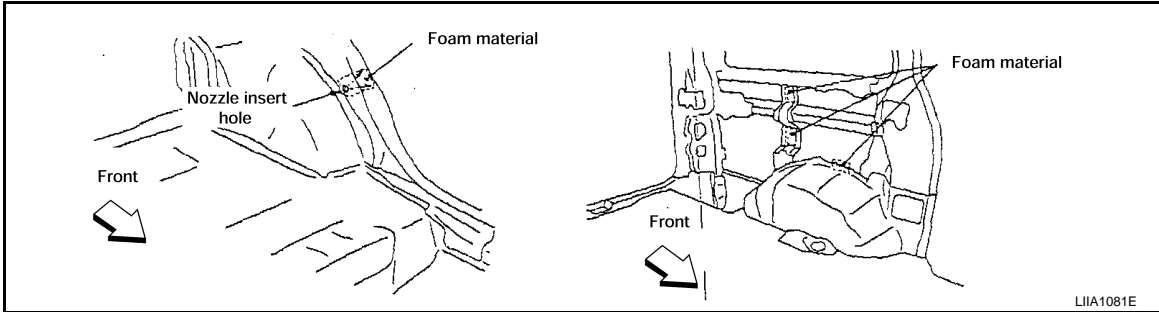

2. Fill procedures before installation of service part.
- Remove foam material remaining on vehicle side.
  - Clean area in which foam was removed.
  - Fill foam material on wheelhouse outer side.

**NOTE:**

Fill in enough to close gap with service part while avoiding flange area.

- Install service part.

**NOTE:**

Refer to label for information on working times.

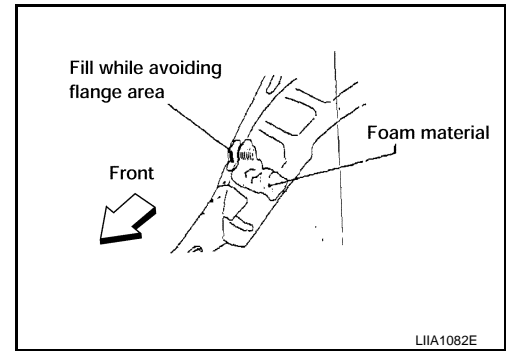

A  
B  
C  
D  
E  
F  
G  
H  
J  
K  
L  
M  
N  
O  
P

BL

# BODY REPAIR

< SERVICE INFORMATION >

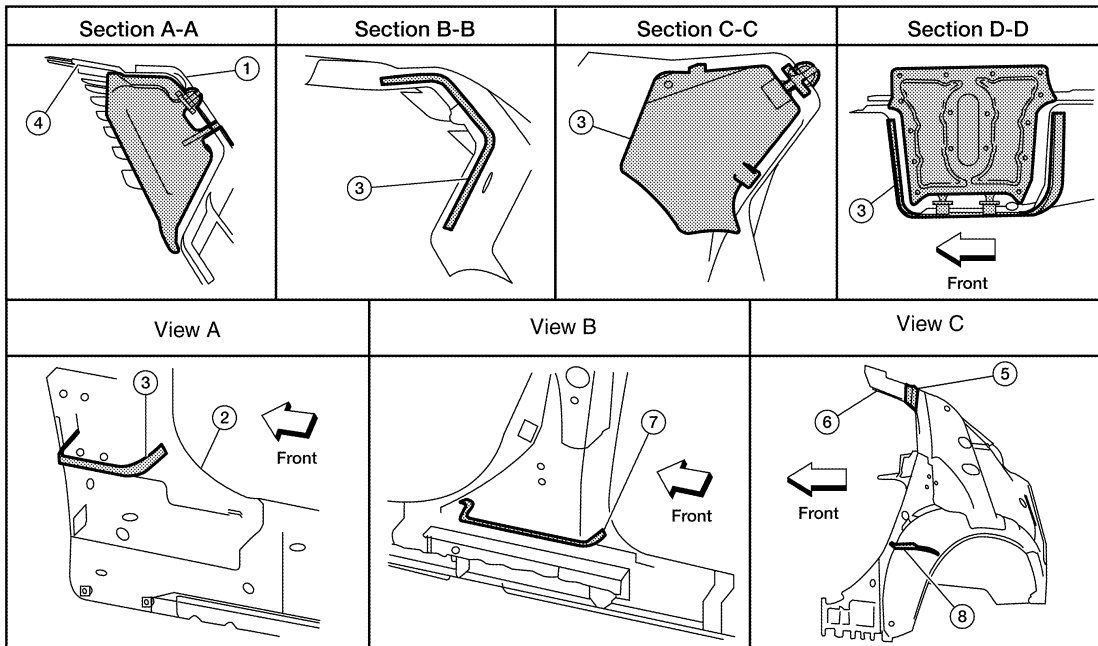
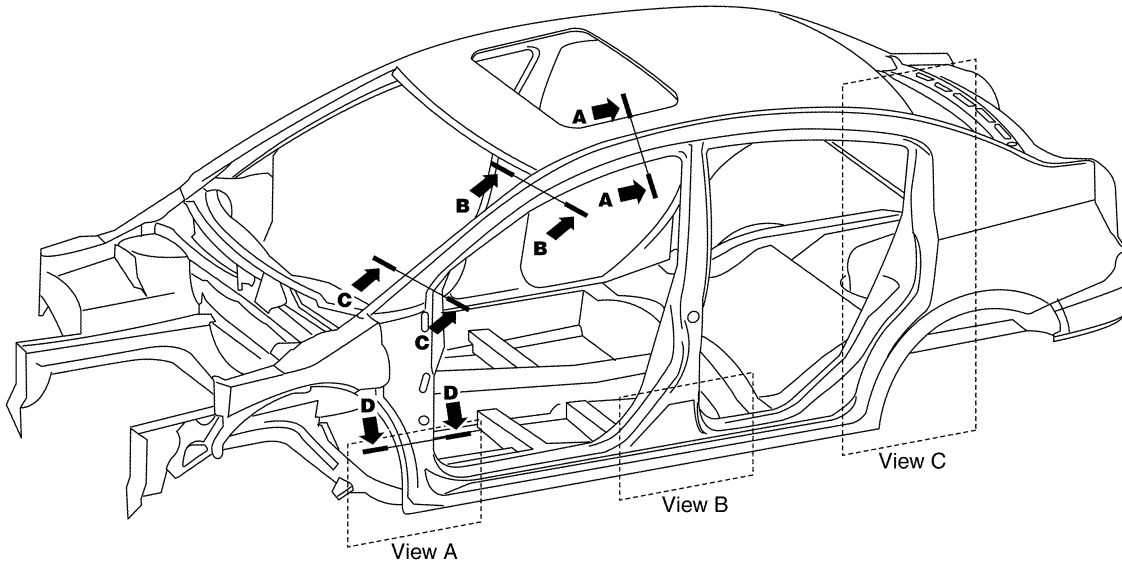

LIA2702E

- |  |  |  |
|--|--|--|
| 1. Body side outer                           | 2. Front pillar lower reinforcement              | 3. Body side insulation (foam) front pillar      |
| 4. Roof panel assembly                       | 5. Body side insulation (Foam) rear roof rail    | 6. Rear roof rail assembly                       |
| 7. Body side insulation strip, center pillar | 8. Body side insulation strip, rear pillar lower | 9. Body side insulation strip, rear pillar upper |

## Replacement Operation

INFOID:000000004407832

### DESCRIPTION



# BODY REPAIR

## < SERVICE INFORMATION >

---

This section is prepared for technicians who have attained a high level of skill and experience in repairing collision-damaged vehicles and also use modern service tools and equipment. Persons unfamiliar with body repair techniques should not attempt to repair collision-damaged vehicles by using this section.

Technicians are also encouraged to read Body Repair Manual (Fundamentals) in order to ensure that the original functions and quality of the vehicle can be maintained. The Body Repair Manual (Fundamentals) contains additional information, including cautions and warnings, that are not including in this manual. Technicians should refer to both manuals to ensure proper repairs.

Please note that this information is prepared for worldwide usage, and as such, certain procedures may not apply in some regions or countries.







A  
B  
C  
D  
E  
F  
G  
H  
J  
K  
L  
M  
N  
O  
P

**BL**

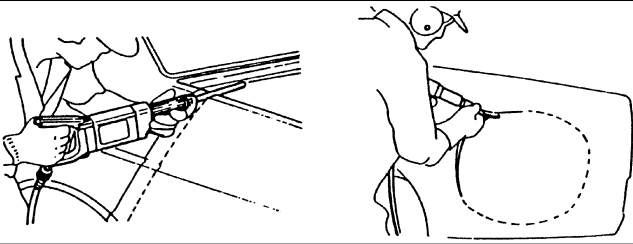
# BODY REPAIR

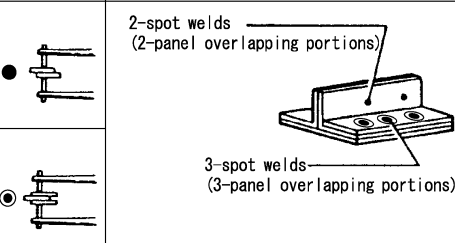
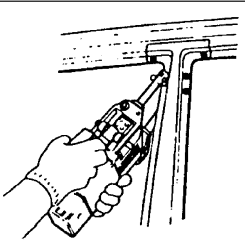
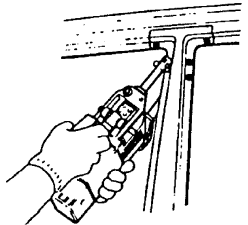
## < SERVICE INFORMATION >

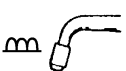
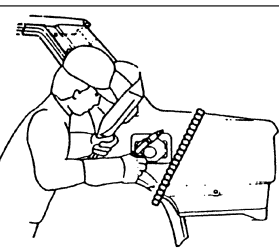
The symbols used in this section for cutting and welding / brazing operations are shown below.

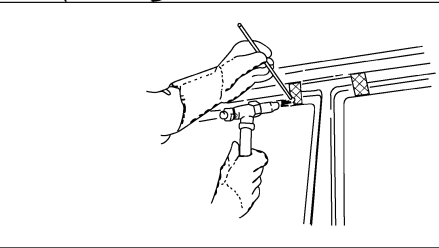
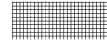
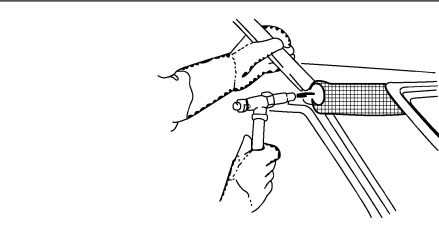
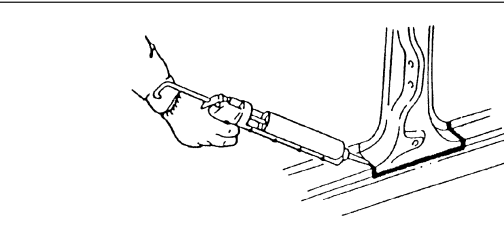
 Saw cut or air chisel cut		
Spot weld  2-spot welds  3-spot welds	 2-spot welds (2-panel overlapping portions)  3-spot welds (3-panel overlapping portions)	
 MIG plug weld   MIG seam weld/ Point weld		
 Brazing		
 Soldering		
Sealing		

PIIA0149E

# BODY REPAIR

## < SERVICE INFORMATION >

- Front pillar butt joint can be determined anywhere within shaded area as shown in the figure. The best location for the butt joint is at position A due to the construction of the vehicle. Refer to the front pillar section.

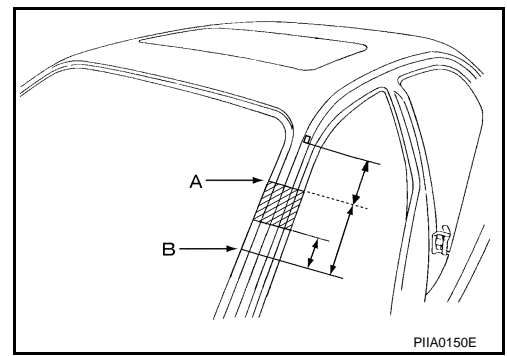

- Determine cutting position and record distance from the locating indent. Use this distance when cutting the service part. Cut outer front pillar over 60 mm above inner front pillar cut position.

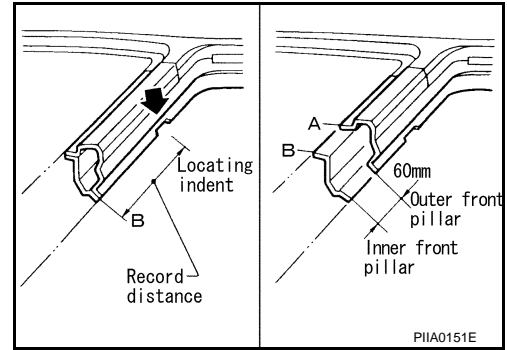

- Prepare a cutting jig to make outer pillar easier to cut. Also, this will permit service part to be accurately cut at joint position.

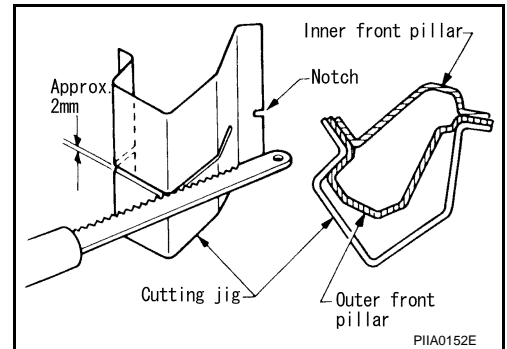

- An example of cutting operation using a cutting jig is as follows.

1. Mark cutting lines.  
A: Cut position of outer pillar  
B: Cut position of inner pillar
2. Align cutting line with notch on jig. Clamp jig to pillar.
3. Cut outer pillar along groove of jig. (At position A)
4. Remove jig and cut remaining portions.
5. Cut inner pillar at position B in same manner.

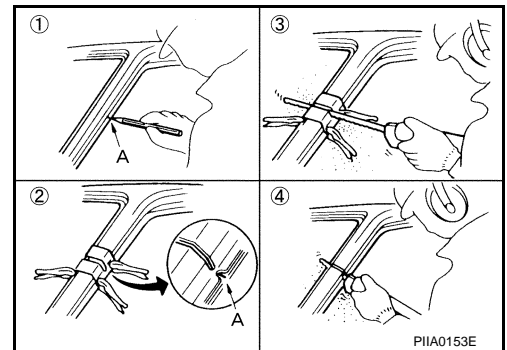

## HOODLEDGE LH

- Work after radiator core support upper and lower have been removed.

# BODY REPAIR

< SERVICE INFORMATION >

## Service Joint

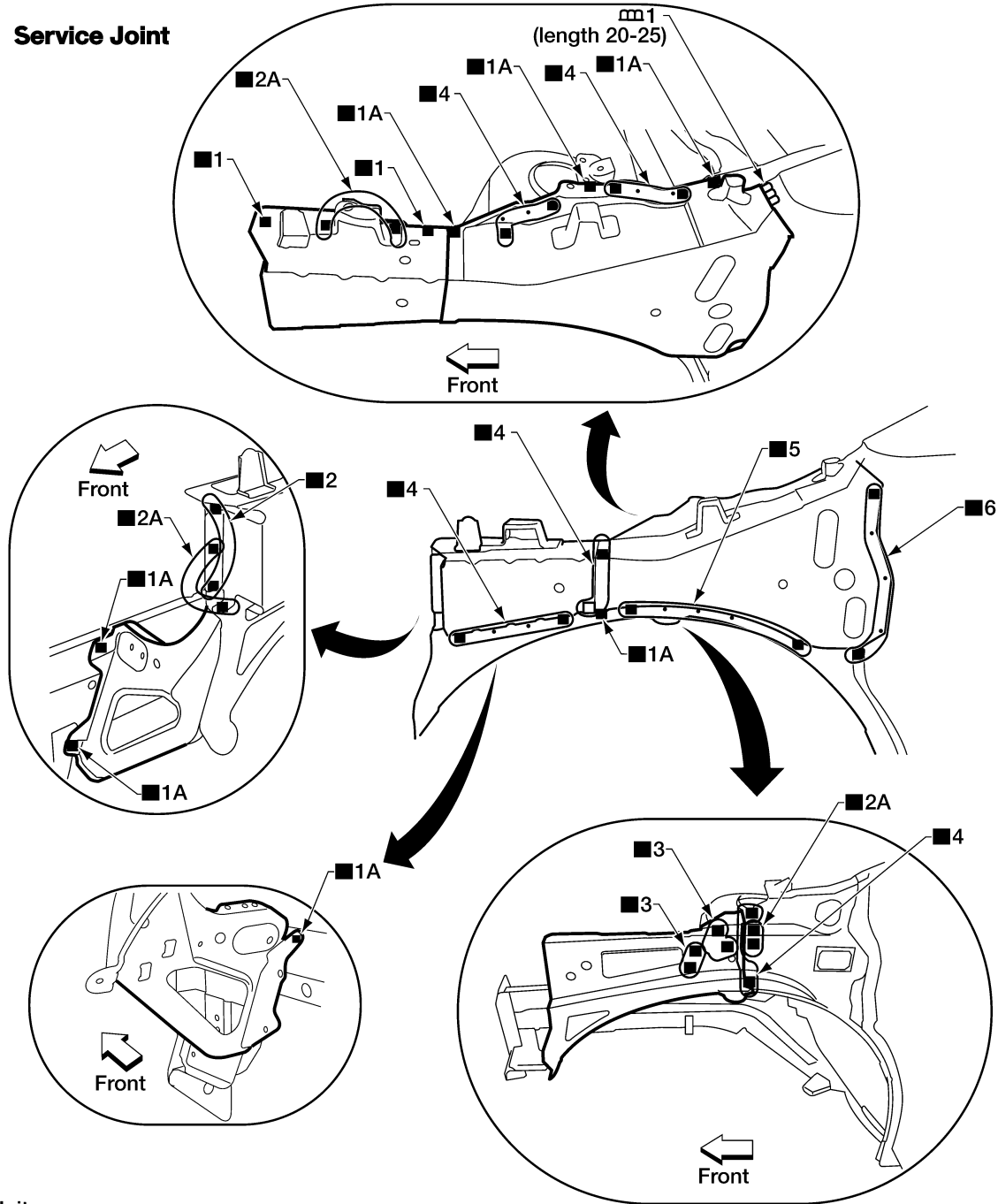

Unit: mm

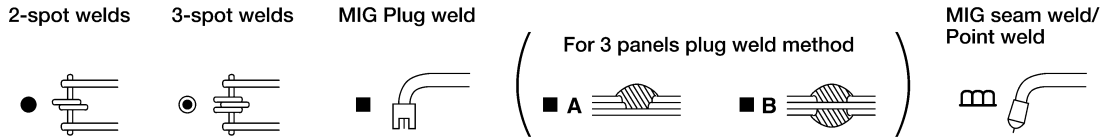

LIA2705E

### Change Parts

- Hoodledge reinforcement assembly
- Cowl top side upper
- Hoodledge connector
- Hoodledge upper
- Fender bracket

## HOODLEDGE RH

- Work after radiator core support upper and lower have been removed.

# BODY REPAIR

< SERVICE INFORMATION >

## Service Joint

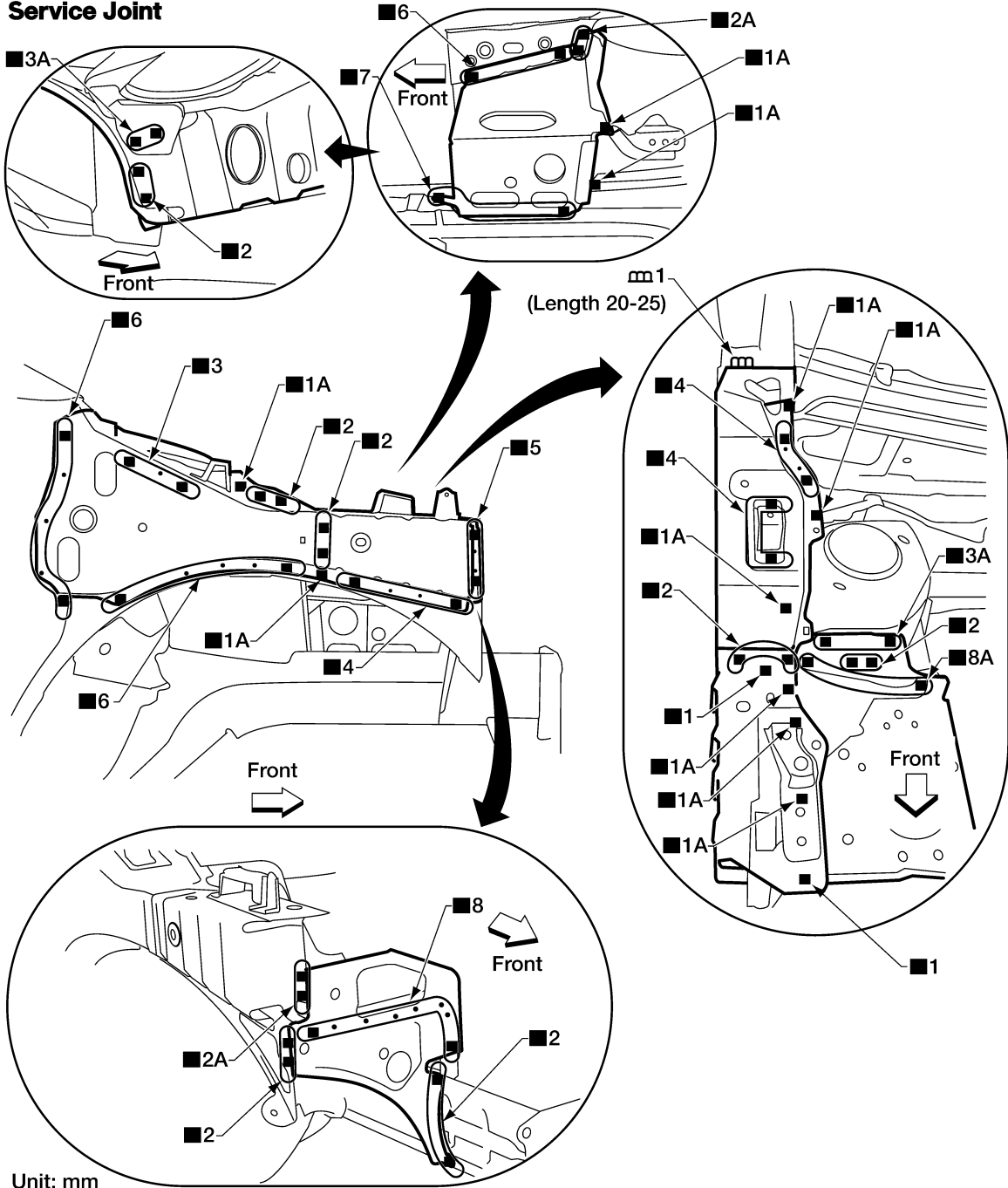

2-spot welds

3-spot welds

MIG Plug weld

( For 3 panels plug weld method )

MIG seam weld/  
Point weld

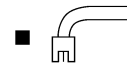
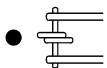

LIA2706E

### Change Parts

- Hoodledge reinforcement assembly
- Hoodledge connector
- Fender bracket
- Cowl top side upper
- Hoodledge upper
- Engine mounting bracket

## FRONT SIDE MEMBER

- Work after hoodledge, radiator core support and outrigger have been removed.

A  
B  
C  
D  
E  
F  
G  
H  
BL  
J  
K  
L  
M  
N  
O  
P

# BODY REPAIR

< SERVICE INFORMATION >

## Service Joint

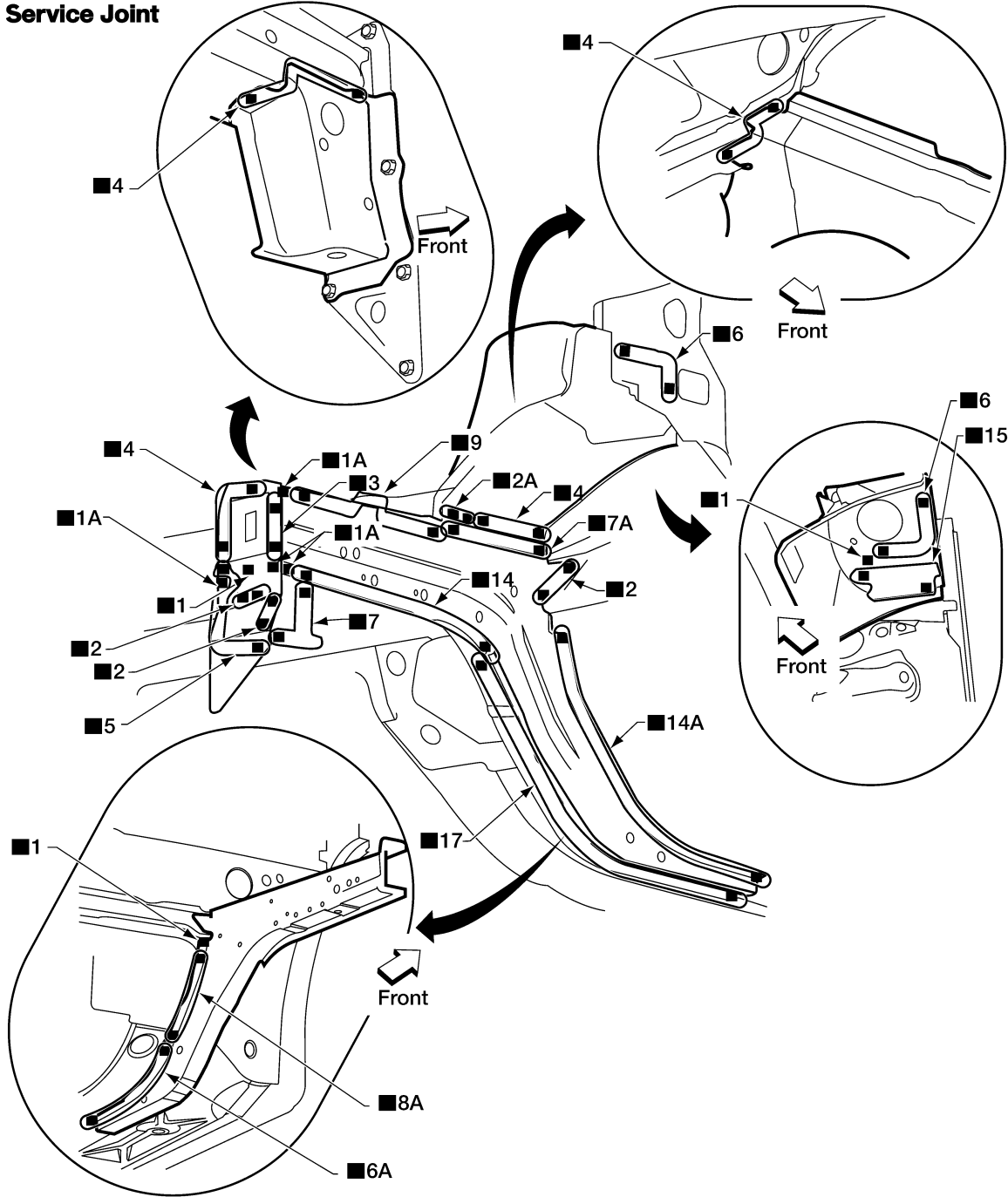

2-spot welds

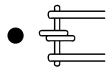

3-spot welds

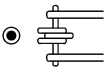

MIG Plug weld



( For 3 panels plug weld method )



MIG seam weld/  
Point weld



LIA2707E

### Change parts

- Front side member
- Front side member closing plate
- Front side member outrigger
- Frame bracket outer
- Front strut housing

## OUTRIGGER

# BODY REPAIR

< SERVICE INFORMATION >

## Service Joint

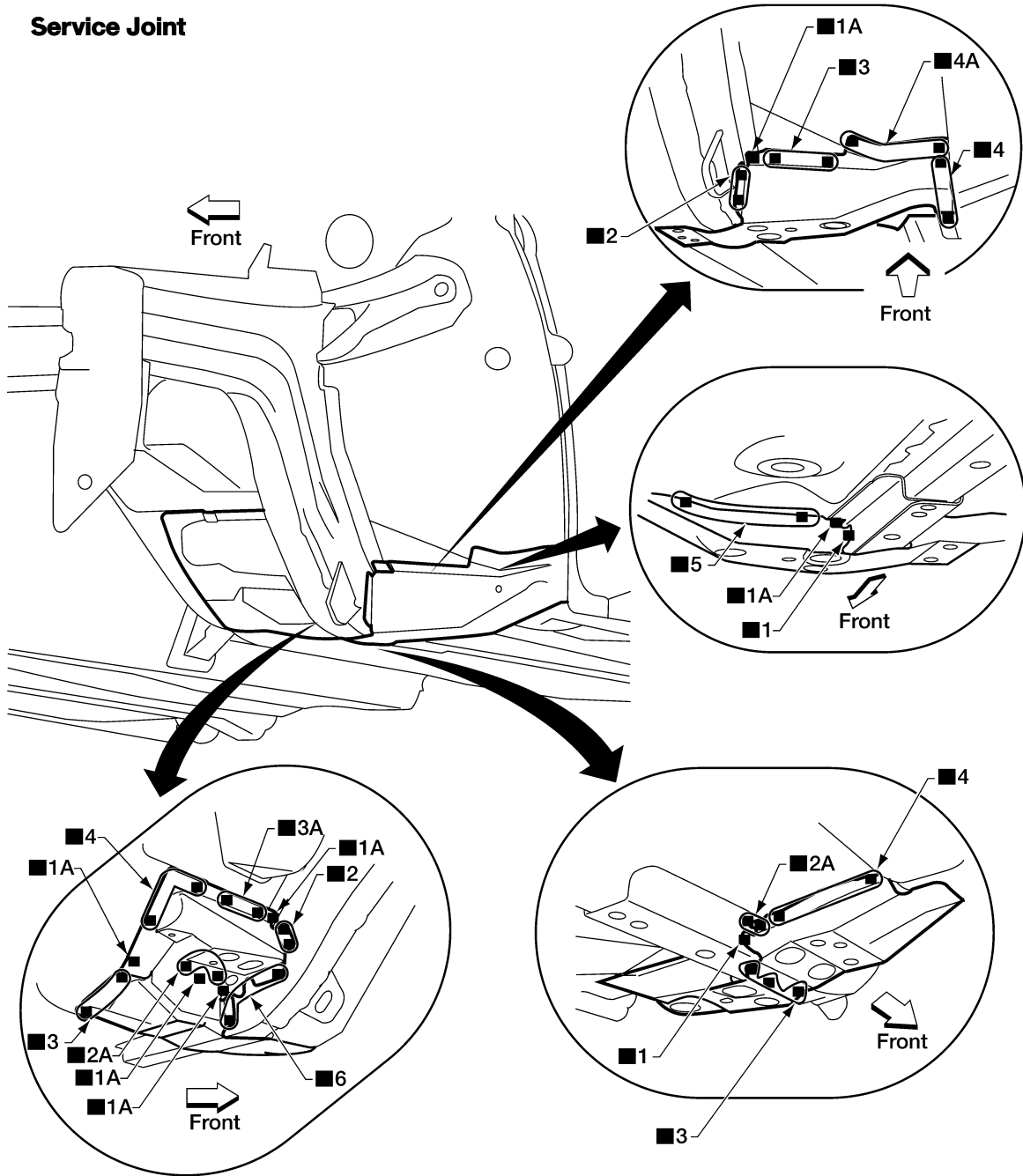

2-spot welds



3-spot welds



MIG Plug weld

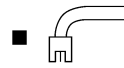

( For 3 panels plug weld method )



MIG seam weld/  
Point weld



LIA2708E

Change parts

- Outrigger

## FRONT PILLAR

- Work after the rear hoodledge reinforcement has been removed.

A  
B  
C  
D  
E  
F  
G  
H  
BL  
J  
K  
L  
M  
N  
O  
P

# BODY REPAIR

< SERVICE INFORMATION >

## Service Joint

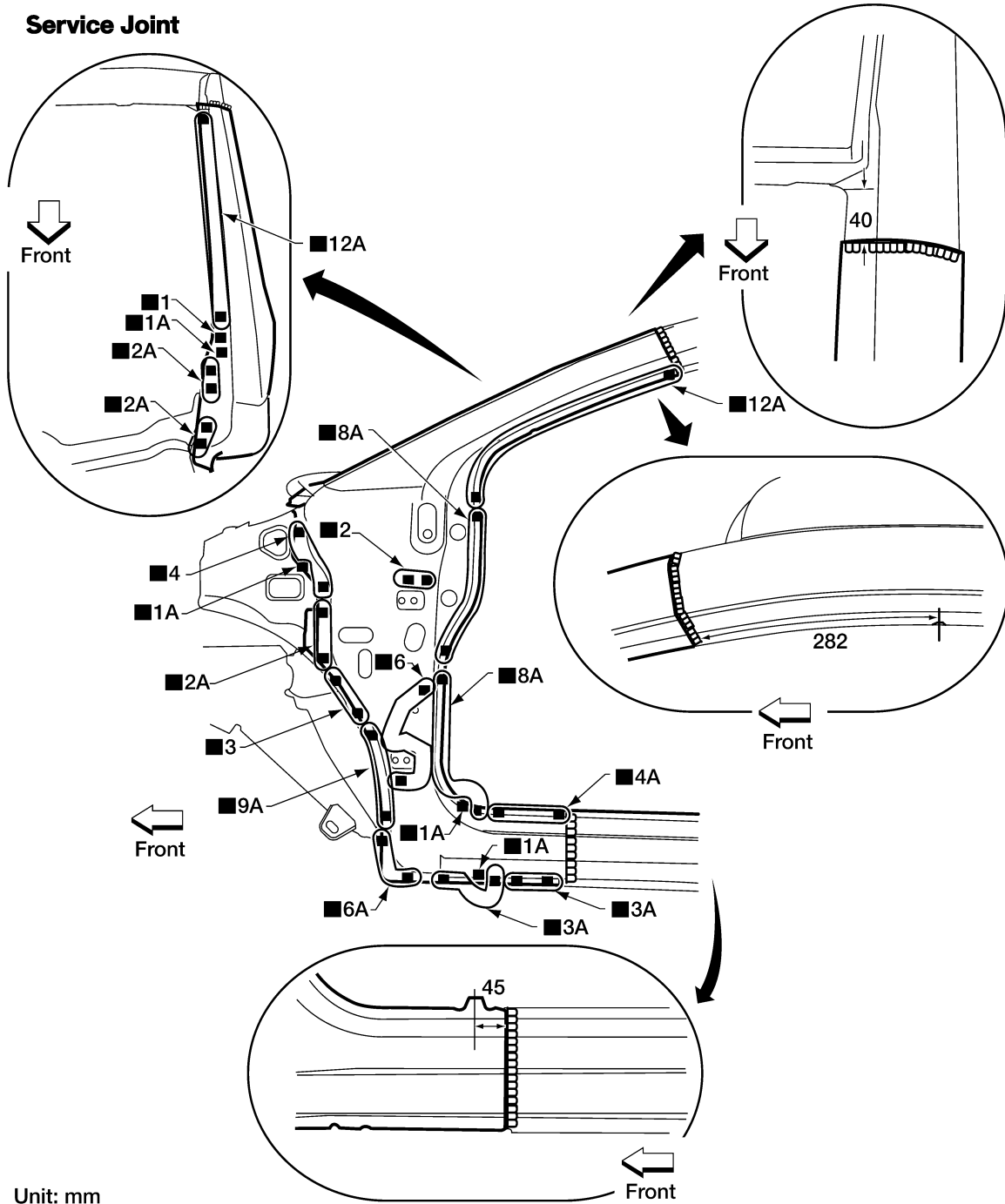

Unit: mm

2-spot welds

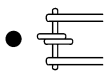

3-spot welds

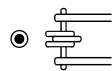

MIG Plug weld

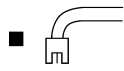

For 3 panels plug weld method

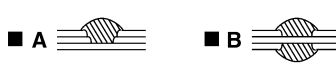

MIG seam weld/  
Point weld



LIA2709E

Change parts

- Front pillar section of body side outer



# BODY REPAIR

< SERVICE INFORMATION >

## Service Joint

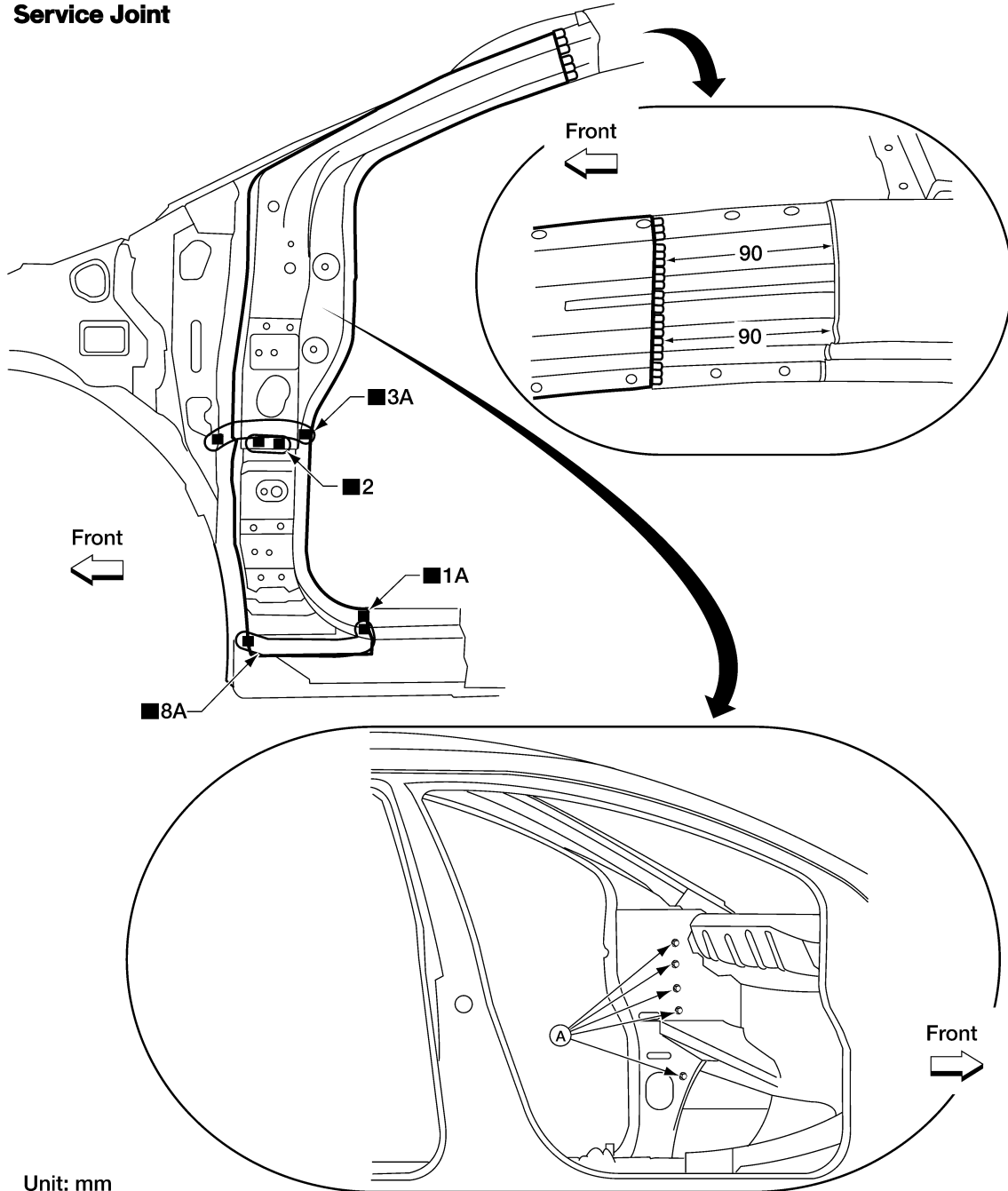

Unit: mm

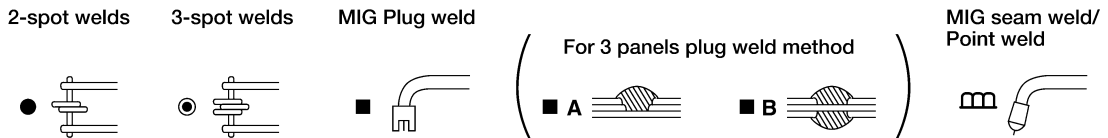

LIA2710E

### Change parts

- Front pillar upper reinforcement
- Front pillar lower reinforcement
- A. Body assembly bolts  
24 Nm (2.4 kg-m, 18 ft-lb)

A  
B  
C  
D  
E  
F  
G  
H  
BL  
J  
K  
L  
M  
N  
O  
P

# BODY REPAIR

< SERVICE INFORMATION >

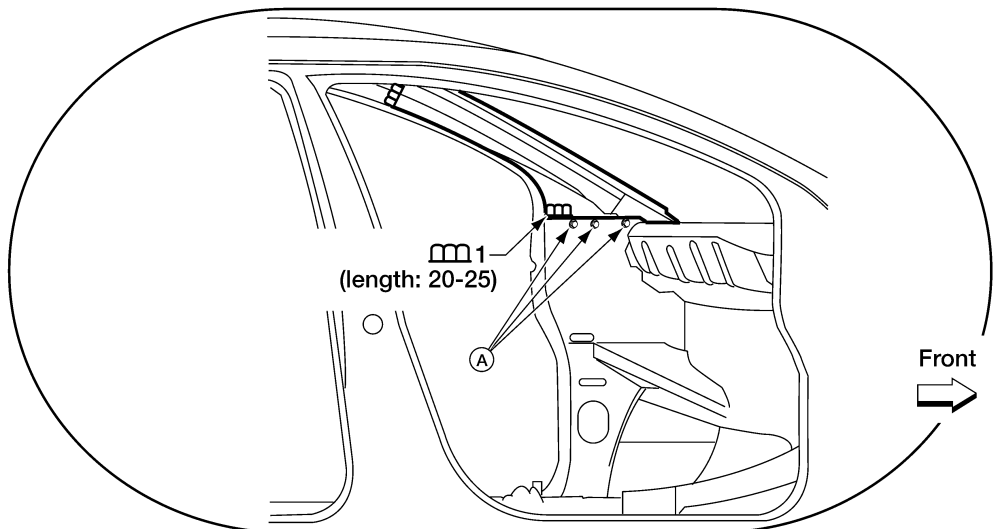
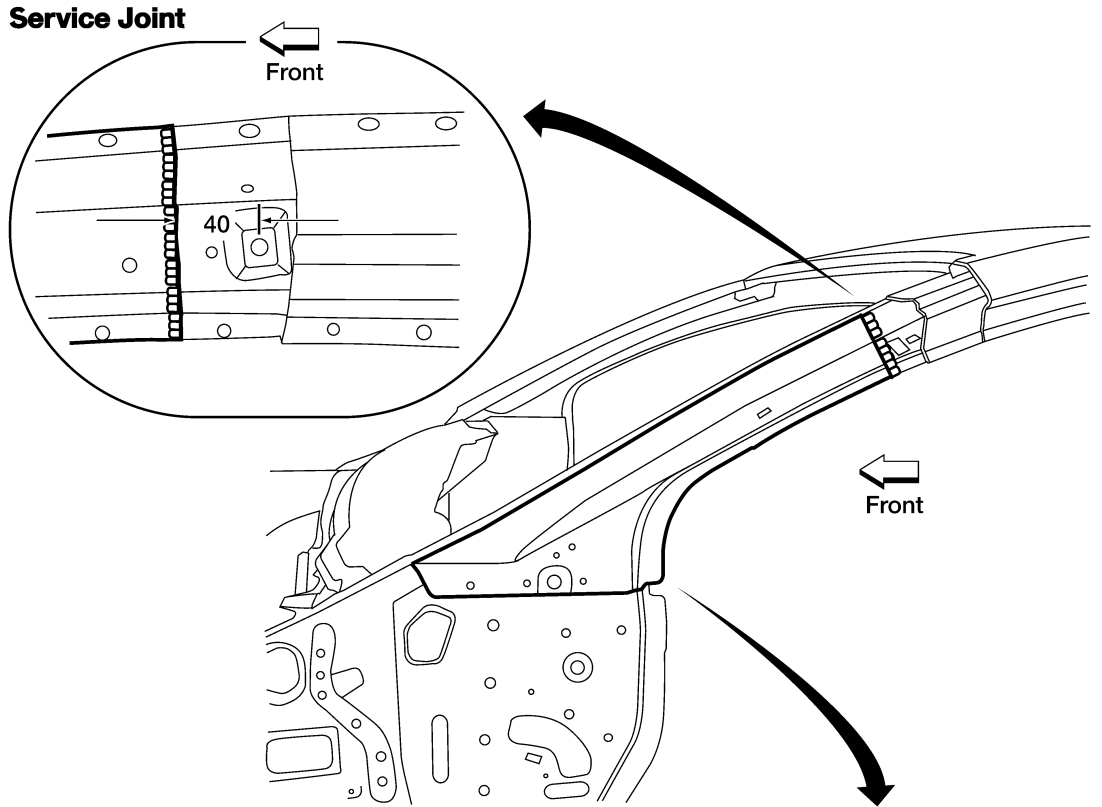

Unit mm

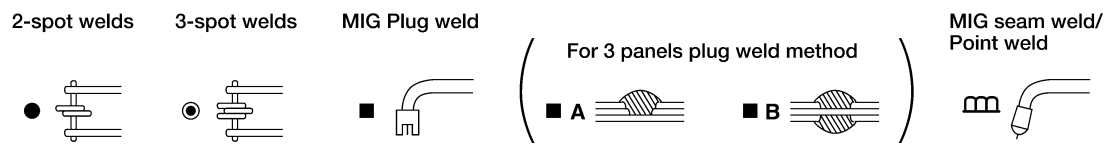

LIA2711E

Change parts

- Front pillar inner reinforcement
- A. Body assembly bolts  
24 Nm (2.4 kg-m, 18 ft-lb)

## DASH SIDE

Work after front pillar and outer sill reinforcement have been removed.

# BODY REPAIR

< SERVICE INFORMATION >

## Service Joint

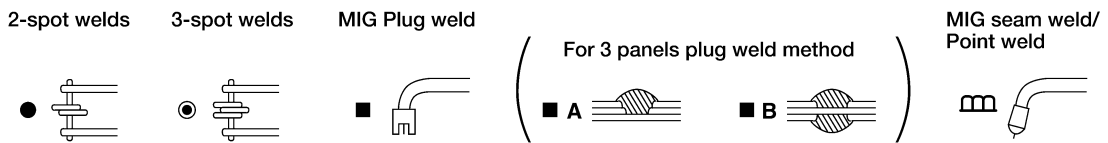
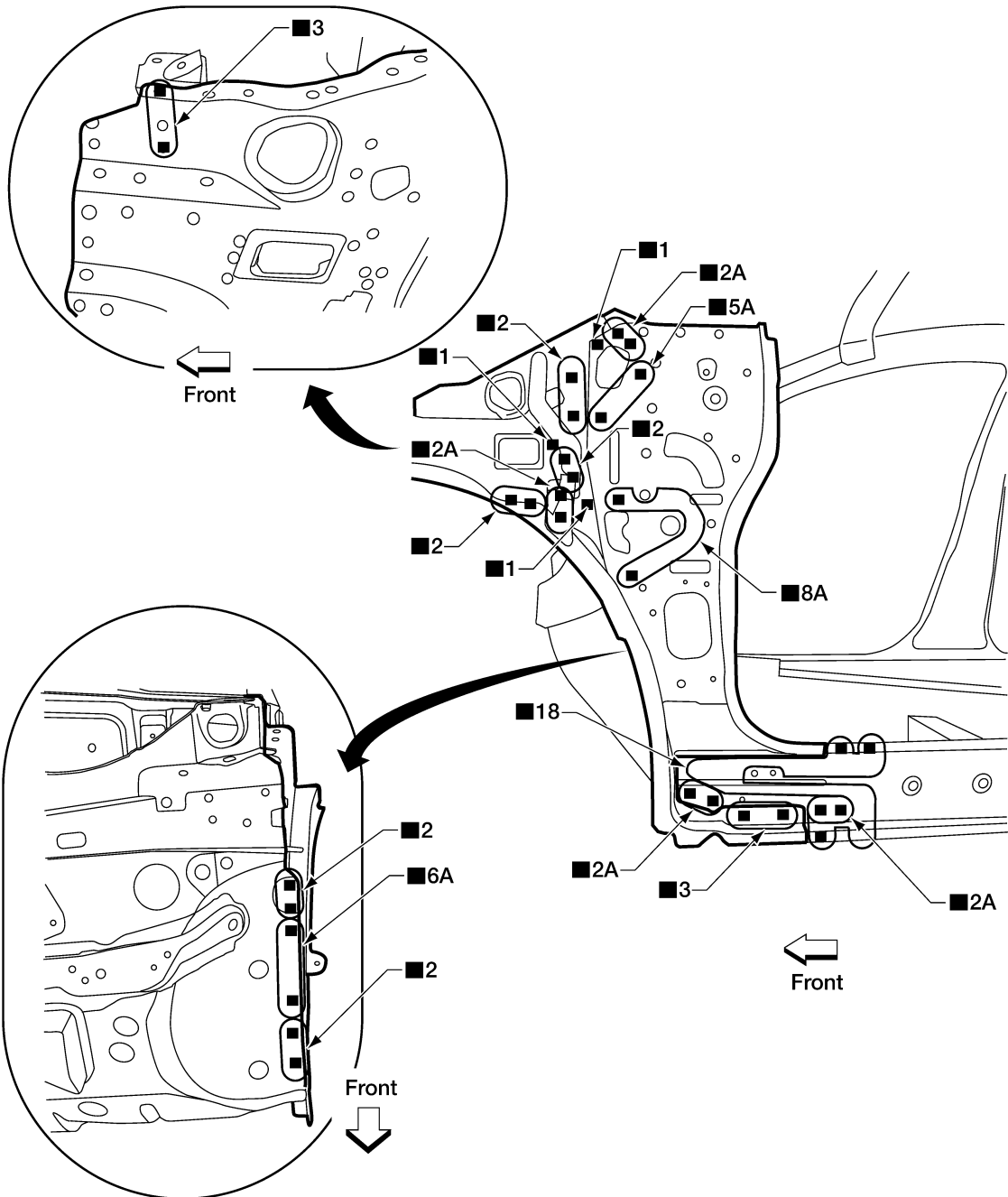

Change parts  
 ● Dash side

## CENTER PILLAR

Outer

A  
 B  
 C  
 D  
 E  
 F  
 G  
 H  
 BL  
 J  
 K  
 L  
 M  
 N  
 O  
 P

# BODY REPAIR

< SERVICE INFORMATION >

## Service Joint

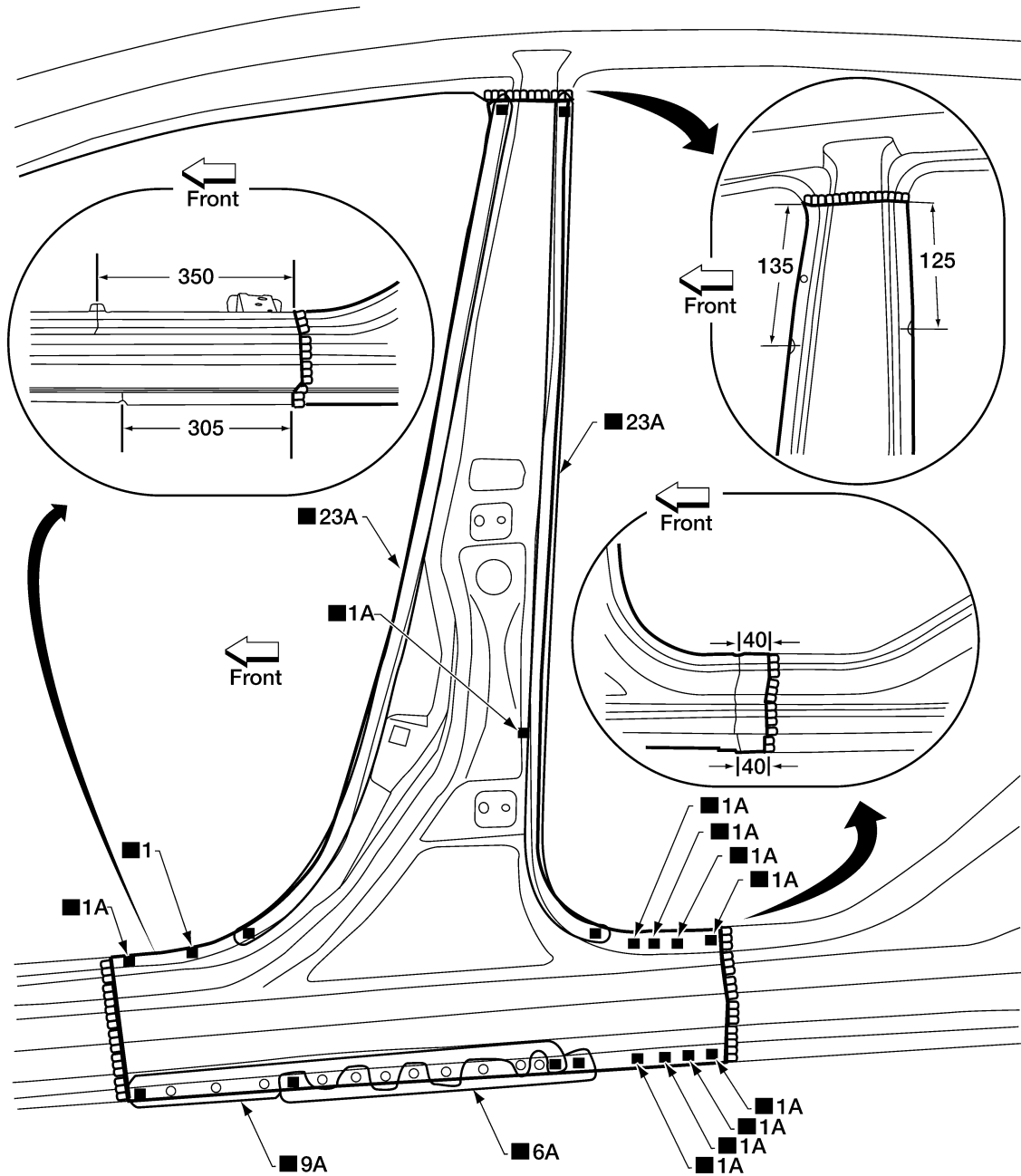

Unit: mm

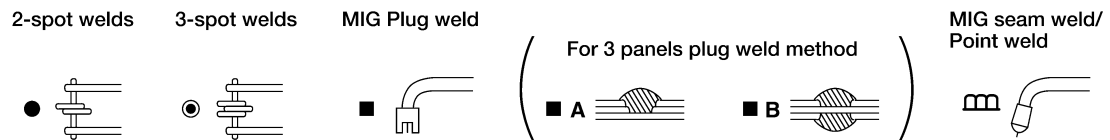

LIA2713E

### Change parts

- Center pillar portion of body side outer

### Reinforcement

# BODY REPAIR

< SERVICE INFORMATION >

## Service Joint

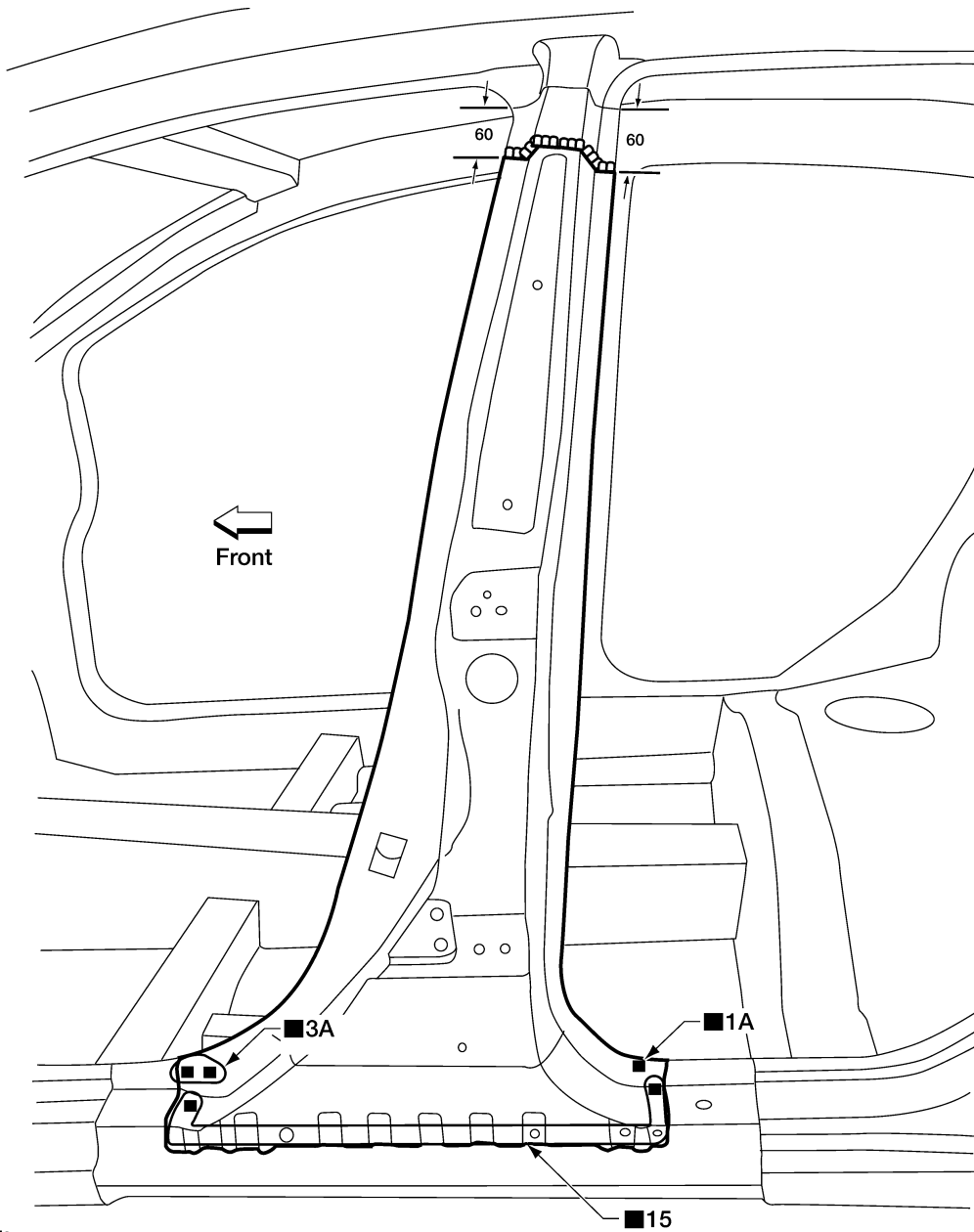

Unit: mm

2-spot welds

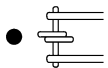

3-spot welds

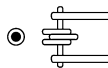

MIG Plug weld

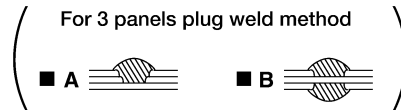
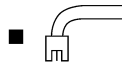

MIG seam weld/  
Point weld



LIA2714E

Change parts

- Center pillar reinforcement

Inner

A  
B  
C  
D  
E  
F  
G  
H  
BL  
J  
K  
L  
M  
N  
O  
P

# BODY REPAIR

< SERVICE INFORMATION >

## Service Joint

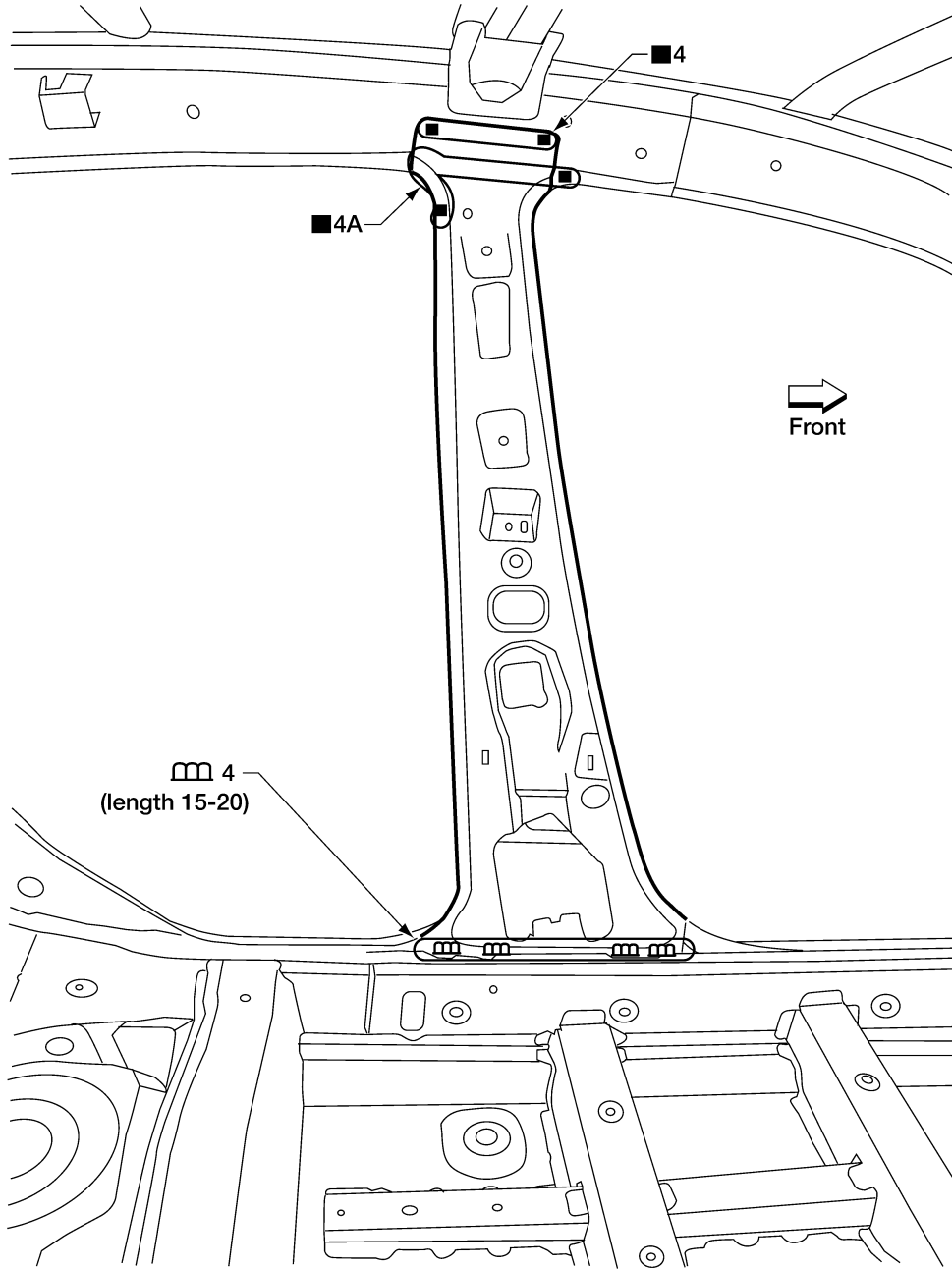

Unit mm

2-spot welds

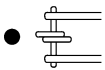

3-spot welds

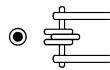

MIG Plug weld

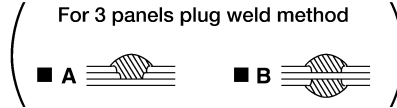
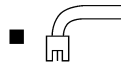

MIG seam weld/  
Point weld



LIA2765E

Change parts

- Inner center pillar

## OUTER SILL REINFORCEMENT

Work after lower front pillar reinforcement, center pillar reinforcement, and rear fender have been removed.

# BODY REPAIR

< SERVICE INFORMATION >

## Service Joint

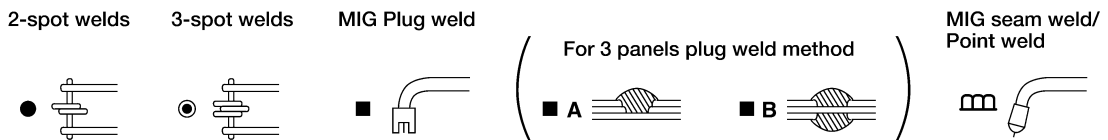
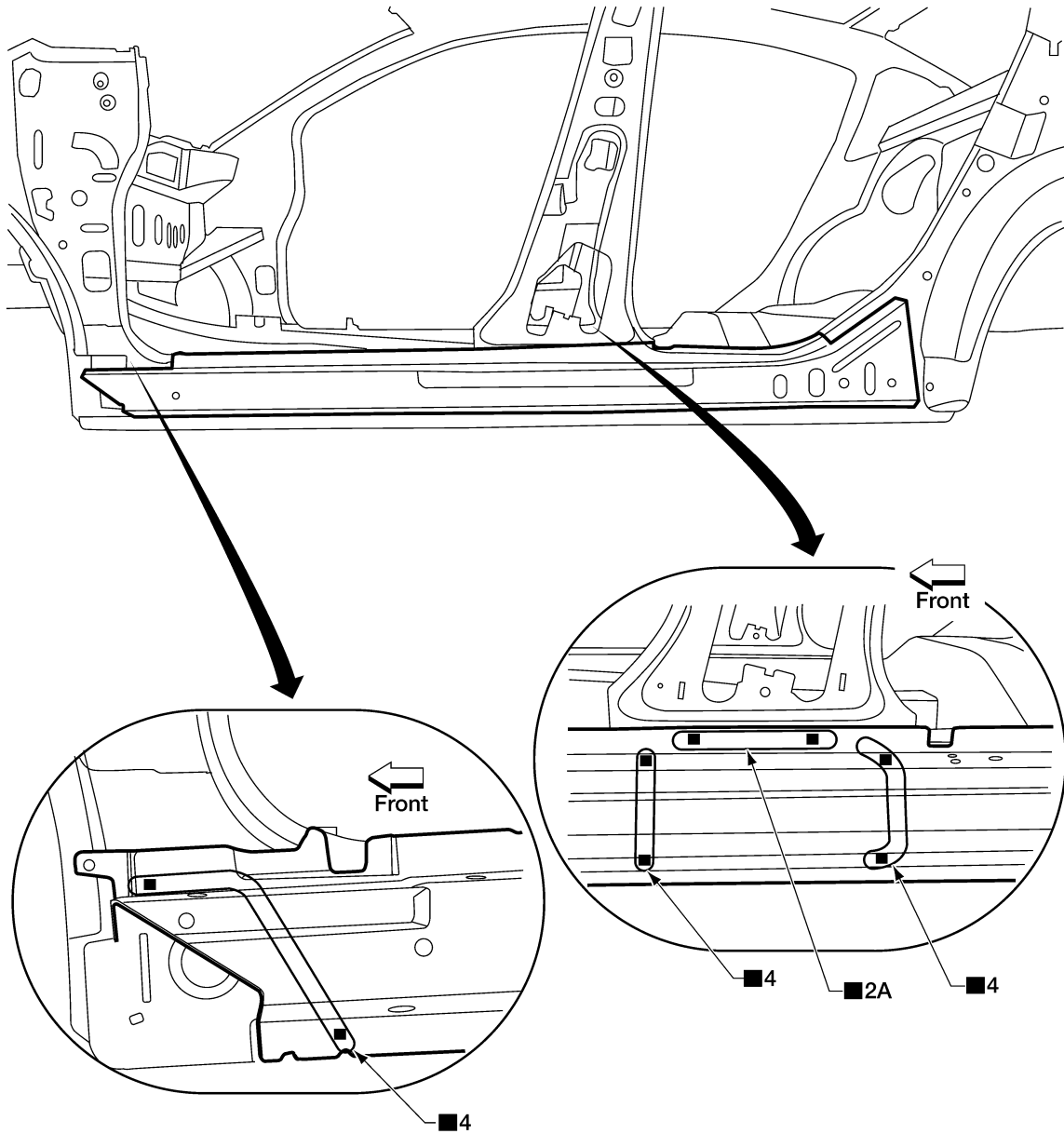

LIA2766E

Change parts

- Outer sill reinforcement

## REAR FENDER

A  
B  
C  
D  
E  
F  
G  
H  
BL  
J  
K  
L  
M  
N  
O  
P

# BODY REPAIR

< SERVICE INFORMATION >

## Service Joint

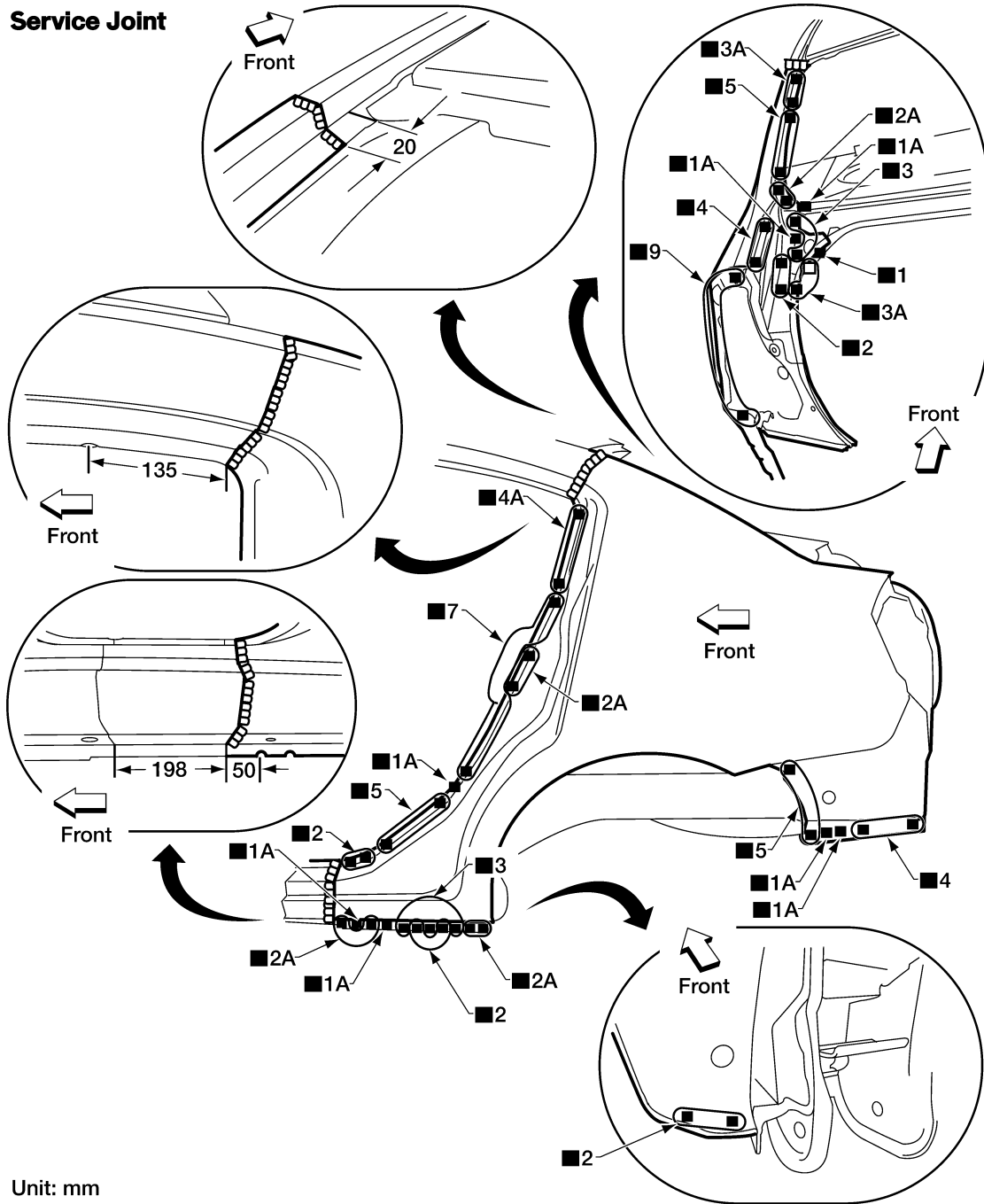

Unit: mm

2-spot welds

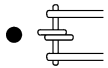

3-spot welds

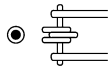

MIG Plug weld

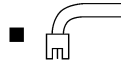

For 3 panels plug weld method



MIG seam weld/  
Point weld



LIA2767E

Change parts

● Rear fender

● Rear fender corner

● Rear combination lamp base

REAR PANEL



# BODY REPAIR

< SERVICE INFORMATION >

## Service Joint

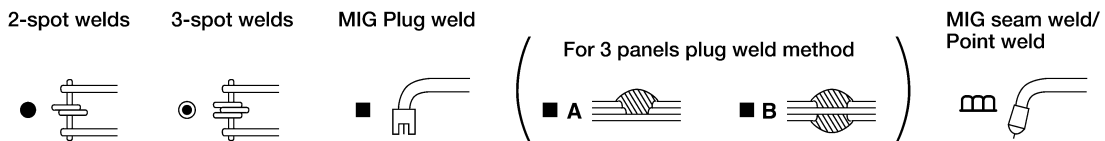
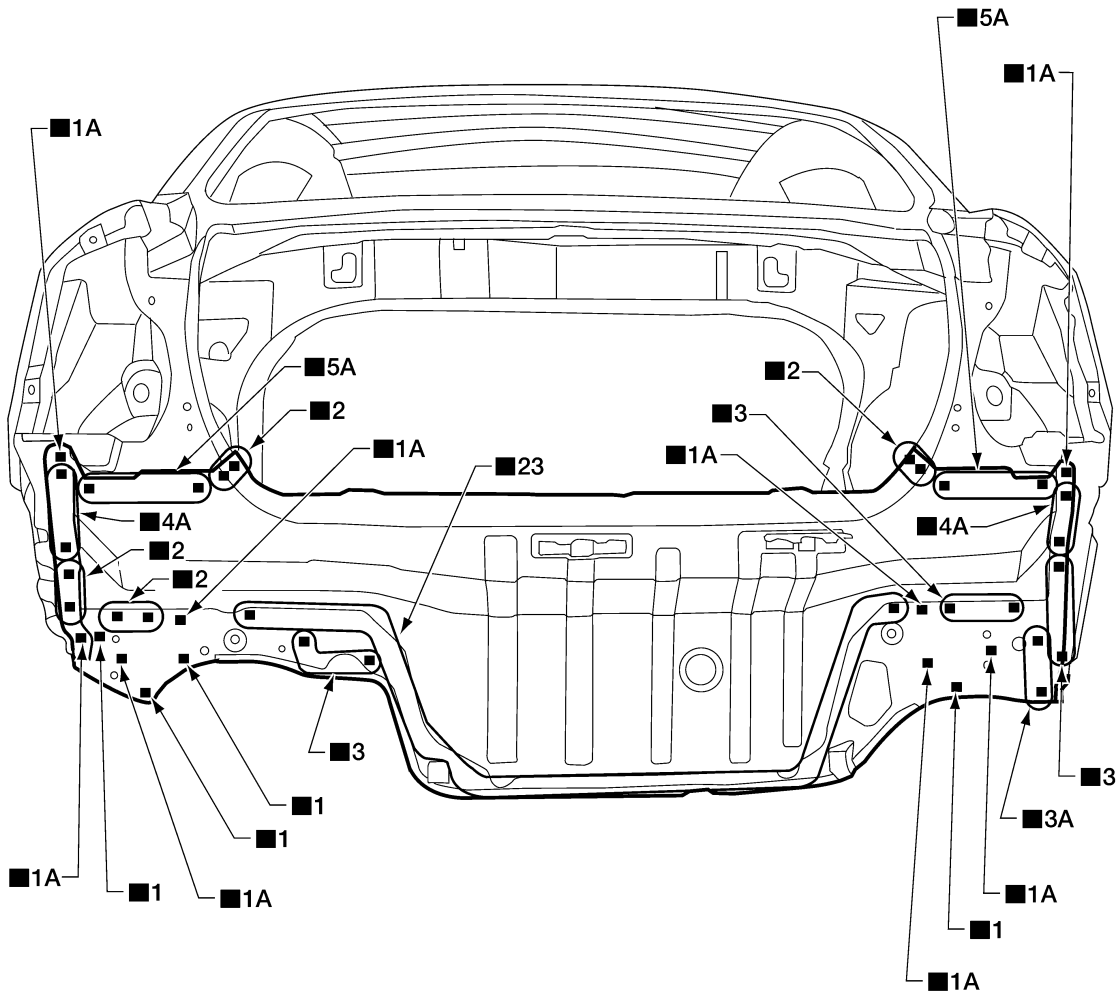

Change parts

- Rear end crossmember
- Rear panel assembly
- Rear bumper fascia brackets

## REAR FLOOR REAR

- Work after rear panel assembly has been removed.

A  
B  
C  
D  
E  
F  
G  
H  
BL  
J  
K  
L  
M  
N  
O  
P

# BODY REPAIR

< SERVICE INFORMATION >

## Service Joint

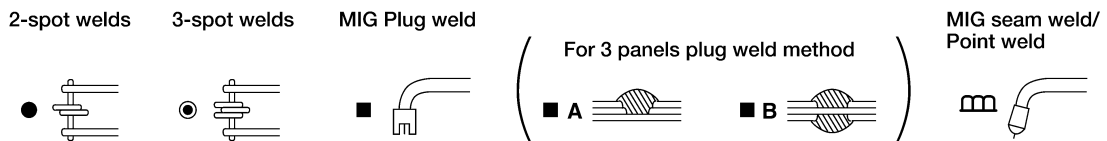
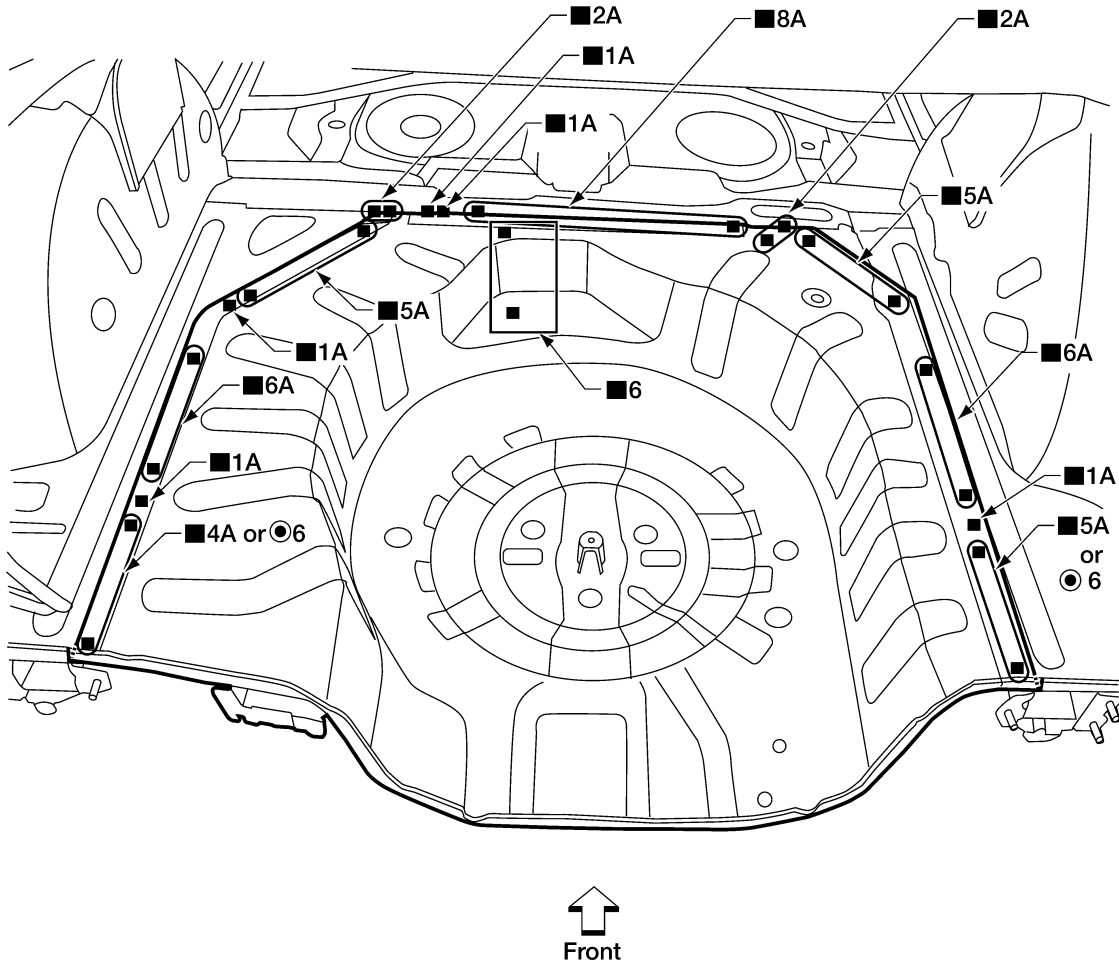

LIA2769E

Change parts

- Rear floor rear

## REAR SIDE MEMBER EXTENSION

- Work after rear panel assembly and rear floor rear have been removed.

# BODY REPAIR

< SERVICE INFORMATION >

## Service Joint

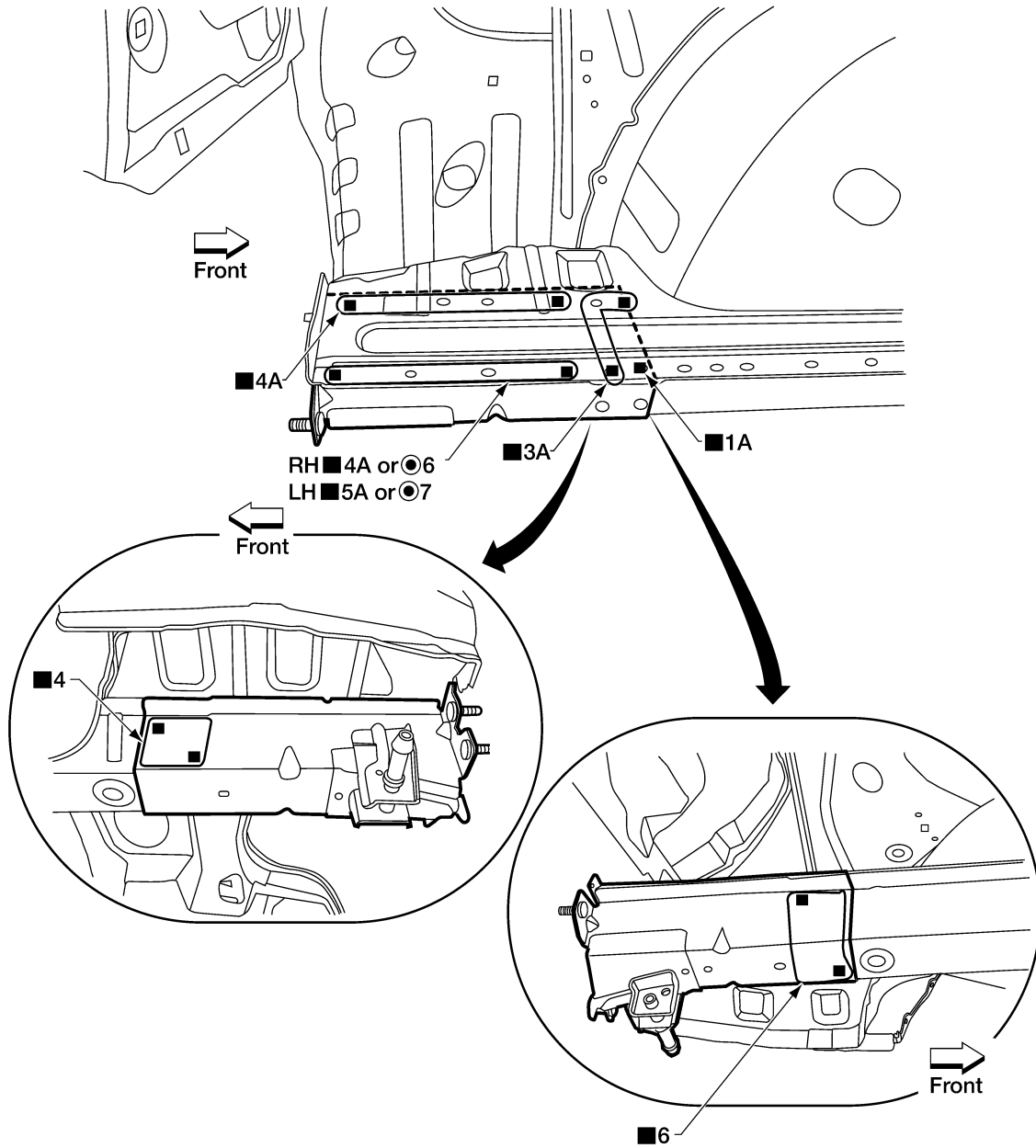

2-spot welds

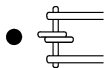

3-spot welds



MIG Plug weld

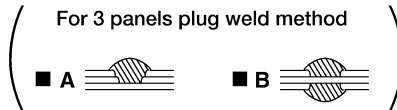
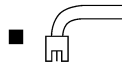

MIG seam weld/  
Point weld



LIA2770E

Change parts

- Rear side member extension

A  
B  
C  
D  
E  
F  
G  
H  
BL  
J  
K  
L  
M  
N  
O  
P