

SECTION **AV**

AUDIO, VISUAL, NAVIGATION & TELEPHONE SYSTEM

CONTENTS

SERVICE INFORMATION	3	Trouble Diagnosis	33	F
PRECAUTIONS	3	Noise Inspection	35	
Precaution for Supplemental Restraint System (SRS) "AIR BAG" and "SEAT BELT PRE-TENSIONER"	3	Power Supply Circuit Inspection	35	
Precaution Necessary for Steering Wheel Rotation After Battery Disconnect	3	Satellite Radio Tuner Power and Ground Supply Circuit Inspection	37	G
PREPARATION	4	Satellite Radio Tuner Communication Circuit Inspection	37	
Commercial Service Tool	4	Satellite Radio Tuner Left Channel Audio Signal Circuit Inspection	39	H
AUDIO	5	Satellite Radio Tuner Right Channel Audio Signal Circuit Inspection	40	I
Component Parts Location	5	Steering Switch Check (With Bluetooth)	40	
System Description	6	Steering Switch Check (Without Bluetooth)	42	
Schematic	8	Sound Is Not Heard from Front Door Speaker or Front Tweeter (Base and Mid System)	43	J
Wiring Diagram - AUDIO -	10	Sound Is Not Heard from Rear Speaker (Base and Mid System)	44	
Audio Unit (Base System) Harness Connector Terminal Layout	21	Sound Is Not Heard from Front Door Speaker or Front Tweeter (Premium System)	46	AV
Terminal and Reference Value for Audio Unit (Base System)	21	Sound Is Not Heard from Rear Speaker Assembly (Premium System)	48	
Audio Unit (Mid System) Harness Connector Terminal Layout	22	Removal and Installation	51	L
Terminal and Reference Value for Audio Unit (Mid System)	22	AUDIO ANTENNA	56	
Audio Unit (Premium System) Harness Connector Terminal Layout	25	Location of Antenna	56	M
Terminal and Reference Value for Audio Unit (Premium System)	25	Removal and Installation of Roof Antenna	56	
Audio Amplifier Harness Connector Terminal Layout (Premium System)	28	TELEPHONE	58	N
Terminal and Reference Value for Audio Amplifier (Premium System)	28	Component Parts and Harness Connector Location	58	
Satellite Radio Tuner Harness Connector Terminal Layout	30	System Description	58	O
Terminal and Reference Value for Satellite Radio Tuner	30	Wiring Diagram - H/PHON -	62	
Audio Unit Self-Diagnosis Function (Base System)	31	Bluetooth Control Unit Harness Connector Terminal Layout	64	P
Audio Unit Self-Diagnosis Function (Mid and Premium System)	33	Terminal and Reference Value for Bluetooth Control Unit	64	
		Bluetooth Control Unit Self-Diagnosis Function	66	
		How to Proceed with Trouble Diagnosis	66	
		Malfunction Code/Symptom Chart	67	
		Power Supply and Ground Circuit Inspection for Bluetooth Control Unit	67	

Steering Wheel Audio Control Switch Does Not Operate	68	System Description	74
Voice Activated Control Function Does Not Operate	69	Schematic	76
Removal and Installation	71	Wiring Diagram - INF/D -	77
INTEGRATED DISPLAY SYSTEM	74	Wiring Diagram - COMM -	81
Component Parts and Harness Connector Location	74	On Board Self-Diagnosis Function	82
		Self-Diagnosis Mode	83
		Trouble Diagnosis Chart by Symptom	86
		Removal and Installation	86

PRECAUTIONS

< SERVICE INFORMATION >

SERVICE INFORMATION

PRECAUTIONS

Precaution for Supplemental Restraint System (SRS) "AIR BAG" and "SEAT BELT PRE-TENSIONER"

INFOID:000000004779235

The Supplemental Restraint System such as "AIR BAG" and "SEAT BELT PRE-TENSIONER", used along with a front seat belt, helps to reduce the risk or severity of injury to the driver and front passenger for certain types of collision. This system includes seat belt switch inputs and dual stage front air bag modules. The SRS system uses the seat belt switches to determine the front air bag deployment, and may only deploy one front air bag, depending on the severity of a collision and whether the front occupants are belted or unbelted. Information necessary to service the system safely is included in the SRS and SB section of this Service Manual.

WARNING:

- To avoid rendering the SRS inoperative, which could increase the risk of personal injury or death in the event of a collision which would result in air bag inflation, all maintenance must be performed by an authorized NISSAN/INFINITI dealer.
- Improper maintenance, including incorrect removal and installation of the SRS can lead to personal injury caused by unintentional activation of the system. For removal of Spiral Cable and Air Bag Module, see the SRS section.
- Do not use electrical test equipment on any circuit related to the SRS unless instructed to in this Service Manual. SRS wiring harnesses can be identified by yellow and/or orange harnesses or harness connectors.
- When working near the Airbag Diagnosis Sensor Unit or other Airbag System sensors with the Ignition ON or engine running, DO NOT use air or electric power tools or strike near the sensor(s) with a hammer. Heavy vibration could activate the sensor(s) and deploy the air bag(s), possibly causing serious injury.
- When using air or electric power tools or hammers, always switch the Ignition OFF, disconnect the battery, and wait at least 3 minutes before performing any service.

Precaution Necessary for Steering Wheel Rotation After Battery Disconnect

INFOID:000000004750048

NOTE:

- This Procedure is applied only to models with Intelligent Key system and NATS (NISSAN ANTI-THEFT SYSTEM).
- Remove and install all control units after disconnecting both battery cables with the ignition knob in the "LOCK" position.
- Always use CONSULT-III to perform self-diagnosis as a part of each function inspection after finishing work. If DTC is detected, perform trouble diagnosis according to self-diagnostic results.

For models equipped with the Intelligent Key system and NATS, an electrically controlled steering lock mechanism is adopted on the key cylinder.

For this reason, if the battery is disconnected or if the battery is discharged, the steering wheel will lock and steering wheel rotation will become impossible.

If steering wheel rotation is required when battery power is interrupted, follow the procedure below before starting the repair operation.

OPERATION PROCEDURE

1. Connect both battery cables.

NOTE:

Supply power using jumper cables if battery is discharged.

2. Use the Intelligent Key or mechanical key to turn the ignition switch to the "ACC" position. At this time, the steering lock will be released.
3. Disconnect both battery cables. The steering lock will remain released and the steering wheel can be rotated.
4. Perform the necessary repair operation.
5. When the repair work is completed, return the ignition switch to the "LOCK" position before connecting the battery cables. (At this time, the steering lock mechanism will engage.)
6. Perform a self-diagnosis check of all control units using CONSULT-III.

PREPARATION

< SERVICE INFORMATION >

PREPARATION

Commercial Service Tool

INFOID:000000004409418

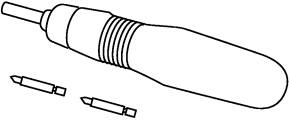
Tool name	Description
<p data-bbox="162 352 272 378">Power tool</p>  <p data-bbox="852 571 922 588">PBIC0191E</p>	<p data-bbox="1015 352 1263 378">Loosening bolts and nuts</p>

AUDIO

< SERVICE INFORMATION >

AUDIO

Component Parts Location

INFOID:000000004409419

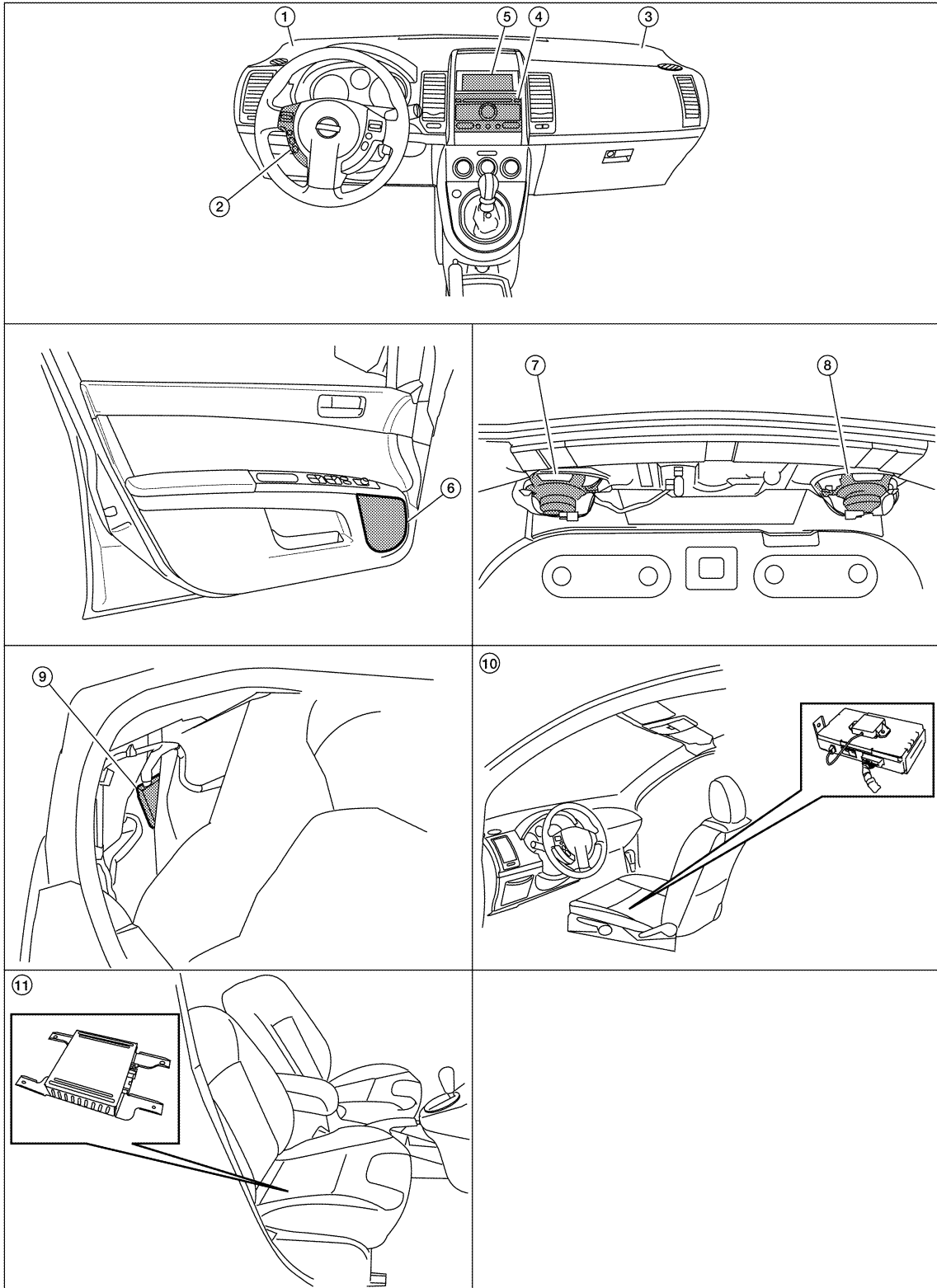

A
B
C
D
E
F
G
H
I
J
AV
L
M
N
O
P

LKIA0853E

AUDIO

< SERVICE INFORMATION >

- | | | |
|---|---|--|
| 1. Front tweeter LH M46 (mid and premium system) | 2. Steering wheel audio control switches (if equipped) | 3. Front tweeter RH M47 (mid and premium system) |
| 4. Audio unit M43, M45, M53, M79 | 5. Display unit (mid and premium system) | 6. Front door speaker
LH D10
RH D108 |
| 7. Rear speaker LH B27 (base and mid system)
Rear speaker assembly LH B40 (premium system) | 8. Rear speaker RH B39 (base and mid system)
Rear speaker assembly RH B38 (premium system) | 9. Satellite radio tuner B56, B60 (with satellite radio tuner) |
| 10. Bluetooth control unit B15 (with Bluetooth) | 11. Audio amplifier B43, B44 (premium system) | |

System Description

INFOID:000000004409420

BASE AND MID SYSTEM

Refer to Owner's Manual for audio system operating instructions.

Power is supplied at all times

- through 20A fuse (No. 31, located in the fuse and fusible link box)
- to audio unit terminal 19.

With the ignition switch in the ACC or ON position, power is supplied

- through 10A fuse [No. 6, located in the fuse block (J/B)]
- to audio unit terminal 7.

Ground is supplied through the case of the audio unit.

Then audio signals are supplied

- through audio unit terminals 2, 3, 4, 5, 11, 12, 13 and 14
- to terminals + and - of front door speaker LH and RH
- to terminals + and - of front tweeter LH and RH (with mid system) and
- to terminals + and - of rear speaker LH and RH.

PREMIUM SYSTEM

Refer to Owner's Manual for audio system operating instructions.

Power is supplied at all times

- through 20A fuse [No. 17, located in the fuse block (J/B)]
- to audio amplifier terminal 17,
- through 20A fuse (No. 31, located in the fuse and fusible link box)
- to audio amplifier terminal 1 and
- to audio unit terminal 19.

With the ignition switch in the ACC or ON position, power is supplied

- through 10A fuse [No. 6, located in the fuse block (J/B)]
- to audio unit terminal 7.

Ground is supplied through the case of the audio unit.

Ground is also supplied

- to audio amplifier terminals 4 and 20
- through body grounds B7 and B19.

Then audio signals are supplied

- through audio unit terminals 2, 3, 4, 5, 11, 12, 13 and 14
- to audio amplifier terminals 5, 6, 7, 8, 21, 22, 23 and 24.

Audio signals are amplified by the audio amplifier.

The amplified audio signals are supplied

- through audio amplifier terminals 2, 3, 11, 12, 13, 14, 15, 16, 18, 19, 27, 28, 29, 30, 31 and 32
- to terminals + and - of front door speaker LH and RH
- to terminals + and - of front tweeter LH and RH
- to terminals 1, 2, 3 and 4 of rear speaker assembly LH and RH.

STEERING WHEEL AUDIO CONTROL SWITCHES (IF EQUIPPED)

When one of steering wheel audio control switches is pushed, the resistance in steering switch circuit changes depending on which button is pushed.

SATELLITE RADIO TUNER (IF EQUIPPED)

Power is supplied at all times

- through 20A fuse (No. 31, located in the fuse and fusible link box)

AUDIO

< SERVICE INFORMATION >

- to satellite radio tuner terminal 32.

With the ignition switch in the ACC or ON position, power is supplied

- through 10A fuse [No. 6, located in the fuse block (J/B)]

- to satellite radio tuner terminal 36.

Ground is supplied through the case of the satellite radio tuner.

Then audio signals are supplied

- through satellite radio tuner terminals 21, 22, 23 and 24

- to audio unit terminals 33, 34, 35 and 36.

SPEED SENSITIVE VOLUME SYSTEM (MID AND PREMIUM SYSTEM)

Volume level of this system goes up and down automatically in proportion to the vehicle speed. The control level can be selected by the customer. Refer to Owner's Manual for operating instructions.

A

B

C

D

E

F

G

H

I

J

AV

L

M

N

O

P

AUDIO

< SERVICE INFORMATION >

Schematic

INFOID:000000004409421

MID SYSTEM

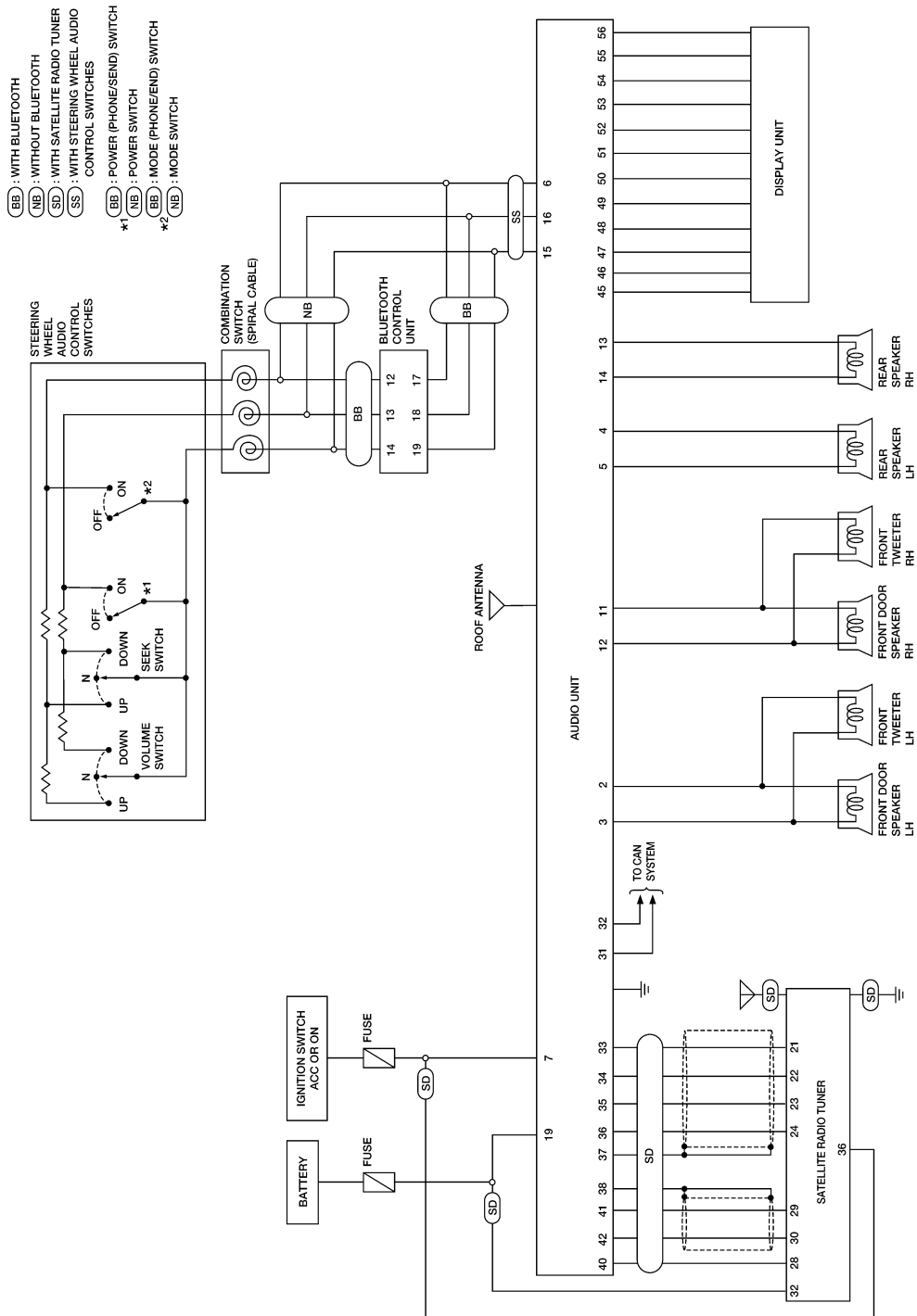

ABNWA0279GE

AUDIO

< SERVICE INFORMATION >
PREMIUM SYSTEM

(MR) : WITH MR20DE

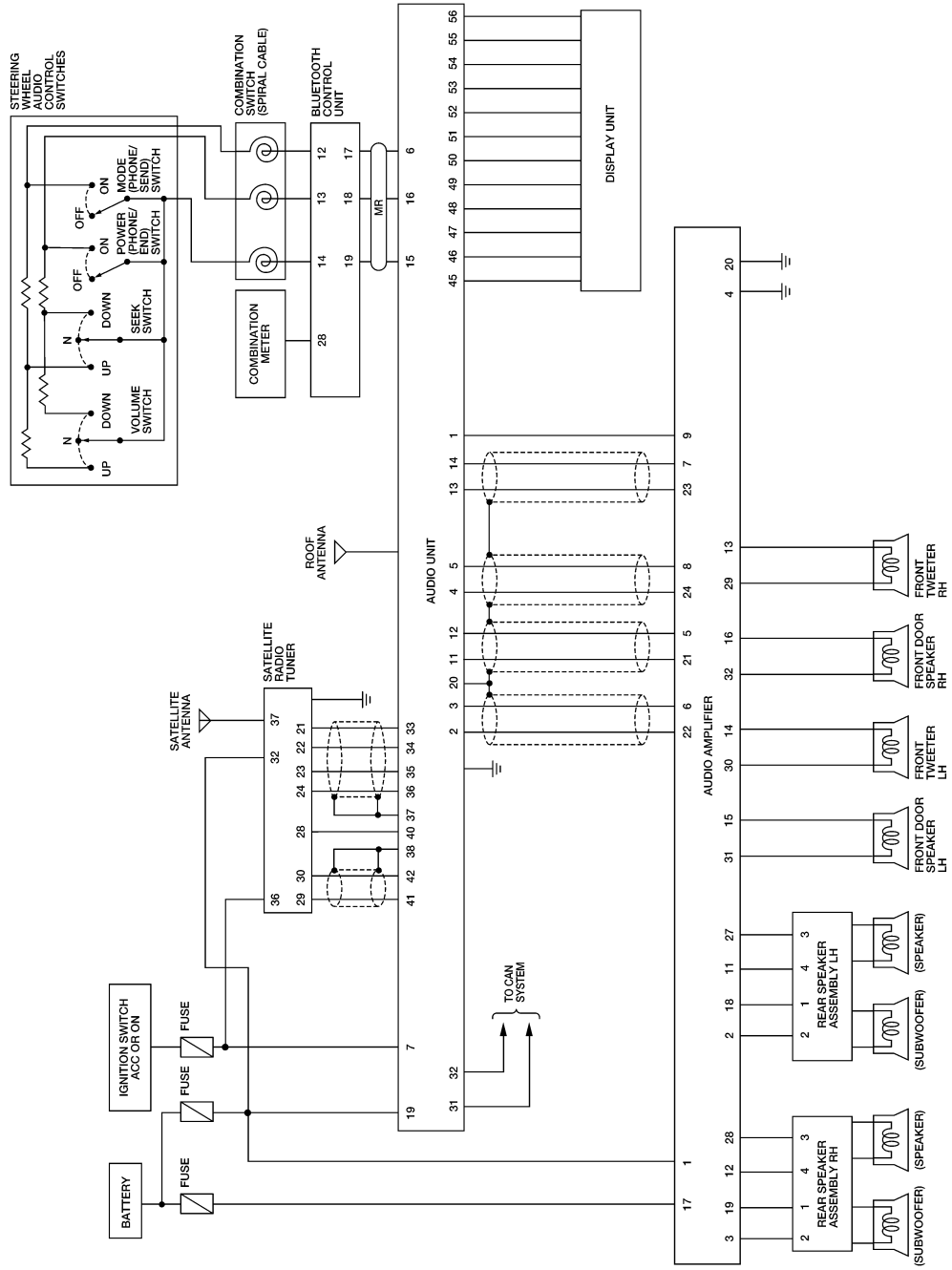

A
B
C
D
E
F
G
H
I
J
K
L
M
N
O
P

AV

ABNWA0280GE

AUDIO

< SERVICE INFORMATION >

Wiring Diagram - AUDIO -

INFOID:000000004409422

BASE SYSTEM

AV-AUDIO-01

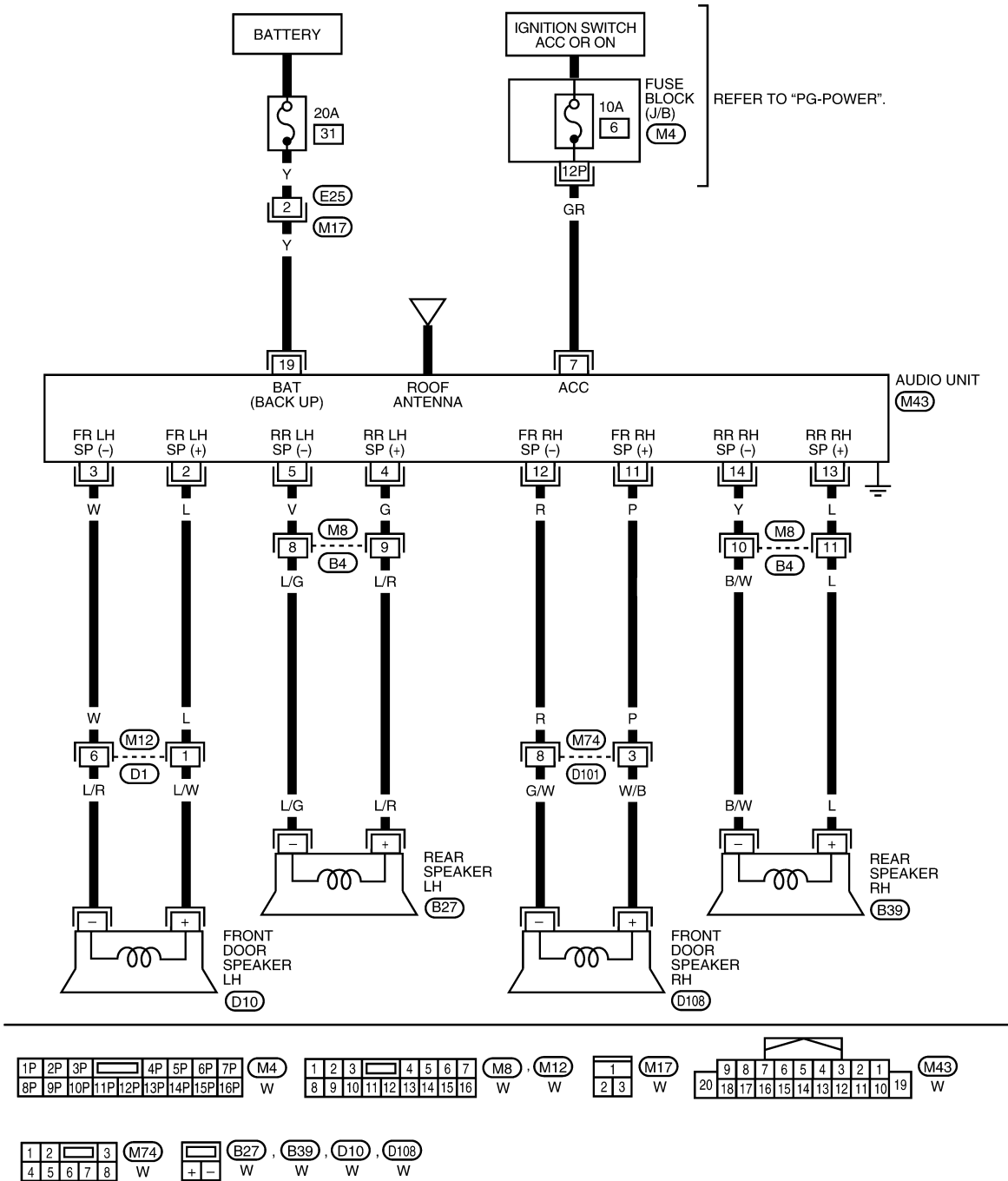

ABNWA0281GE

AUDIO

< SERVICE INFORMATION >

MID SYSTEM

AV-AUDIO-02

SD : WITH SATELLITE RADIO TUNER

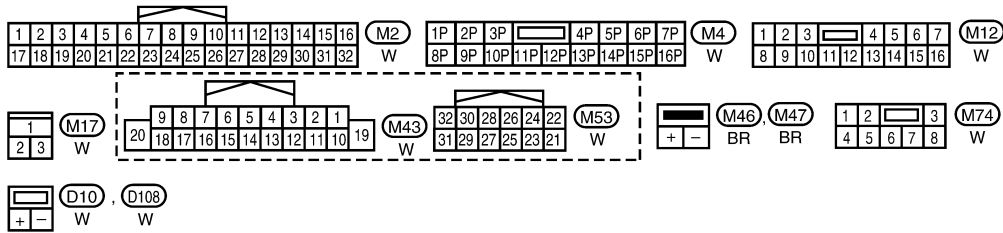
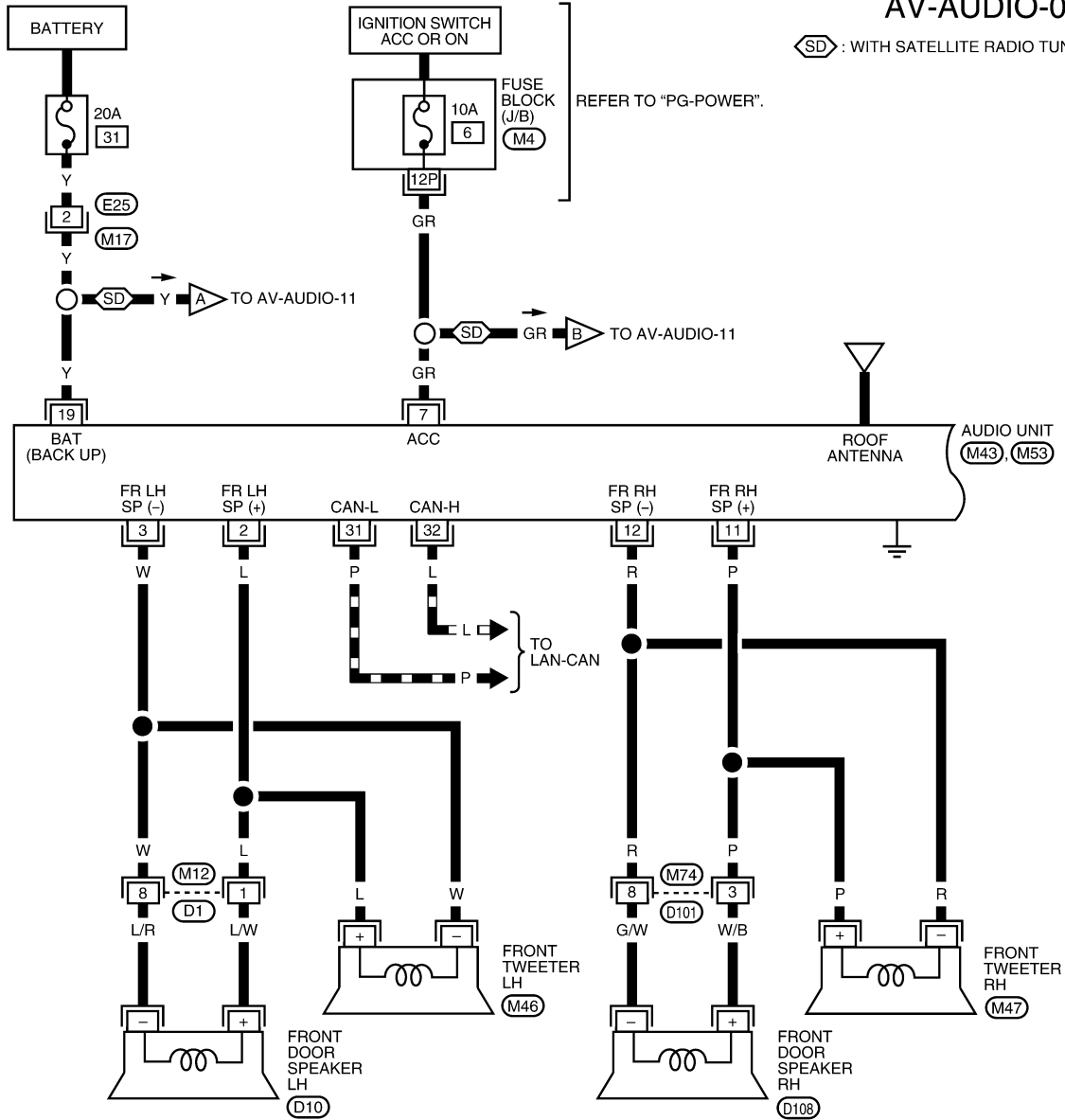

AWKWA0090GI

AUDIO

< SERVICE INFORMATION >

AV-AUDIO-03

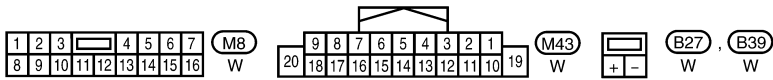
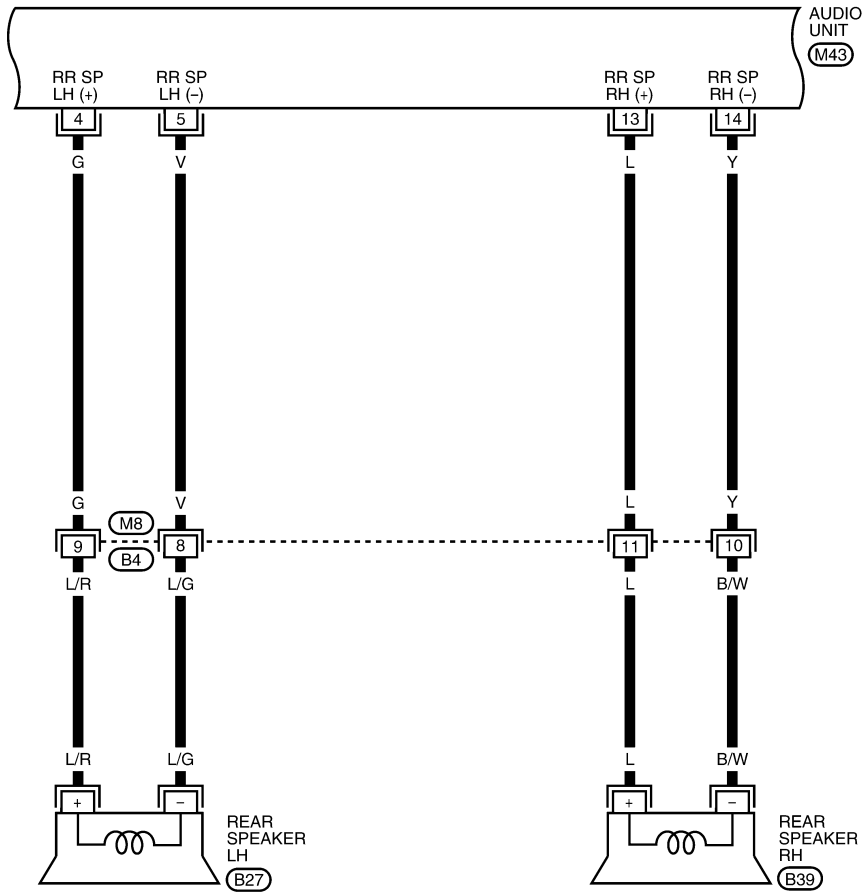

ABNWA0283GE

AUDIO

< SERVICE INFORMATION >

Without Bluetooth

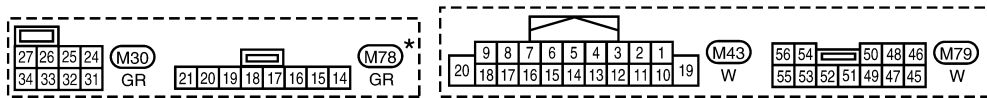
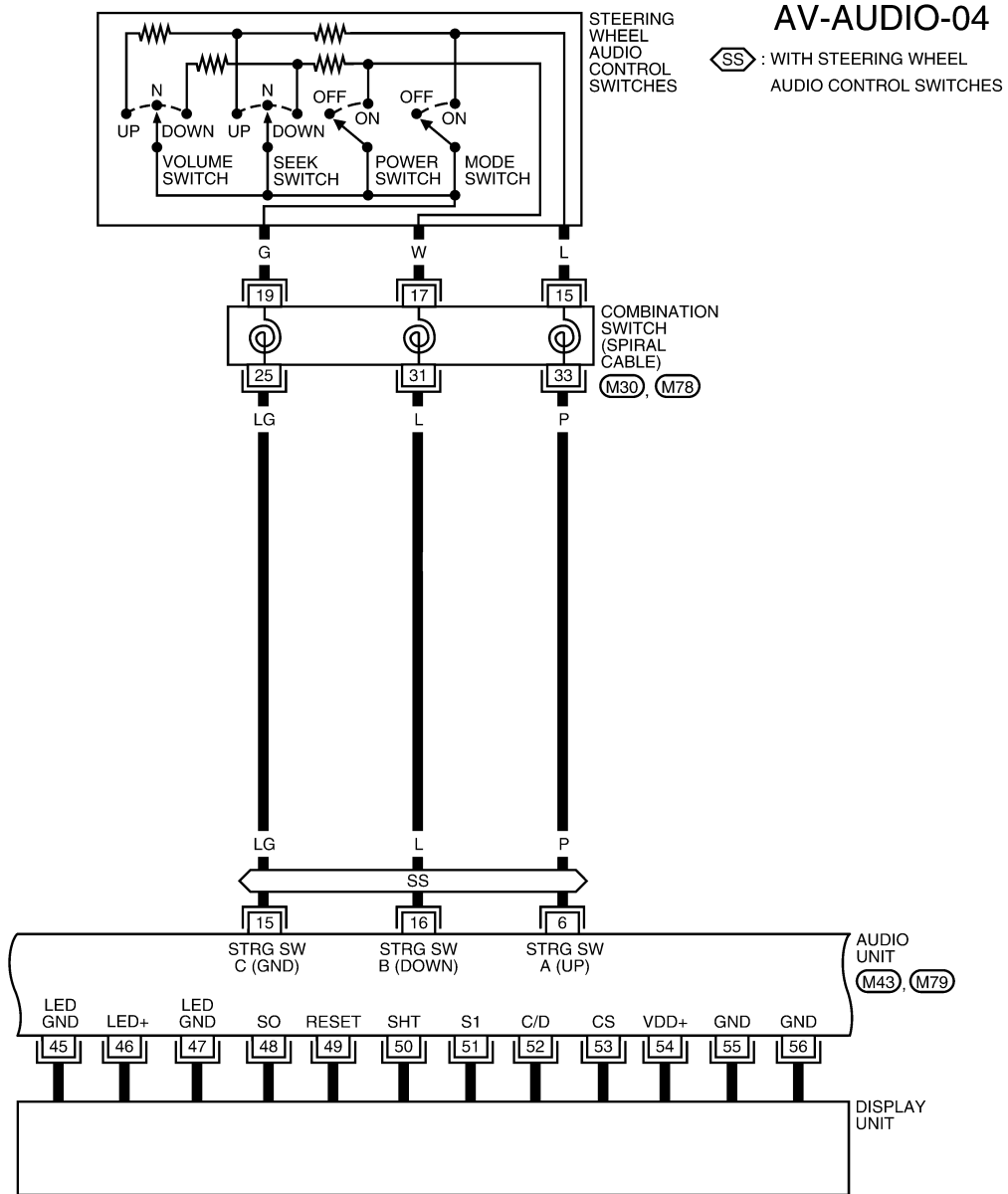

* : THIS CONNECTOR IS NOT SHOWN IN "HARNESS LAYOUT" OF PG SECTION.

ABNWA0284GE

A
B
C
D
E
F
G
H
I
J
AV
L
M
N
O
P

AUDIO

< SERVICE INFORMATION >

With Bluetooth

AV-AUDIO-05

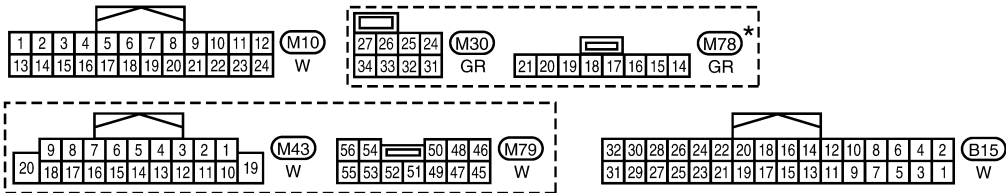
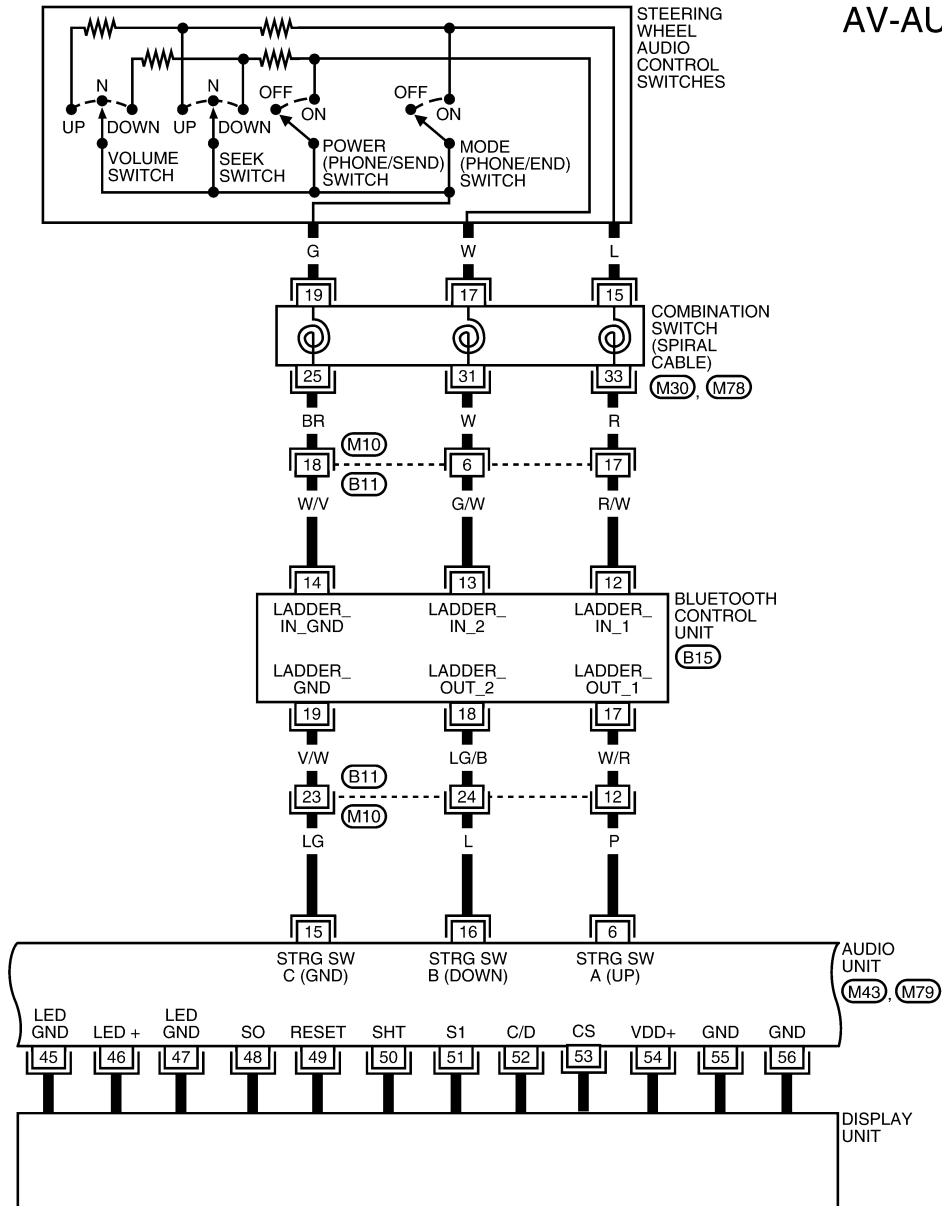

* : THIS CONNECTOR IS NOT SHOWN IN "HARNESS LAYOUT" OF PG SECTION.

BKWA0762E

AUDIO

< SERVICE INFORMATION >

PREMIUM SYSTEM

AV-AUDIO-06

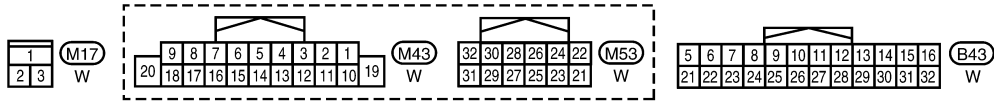
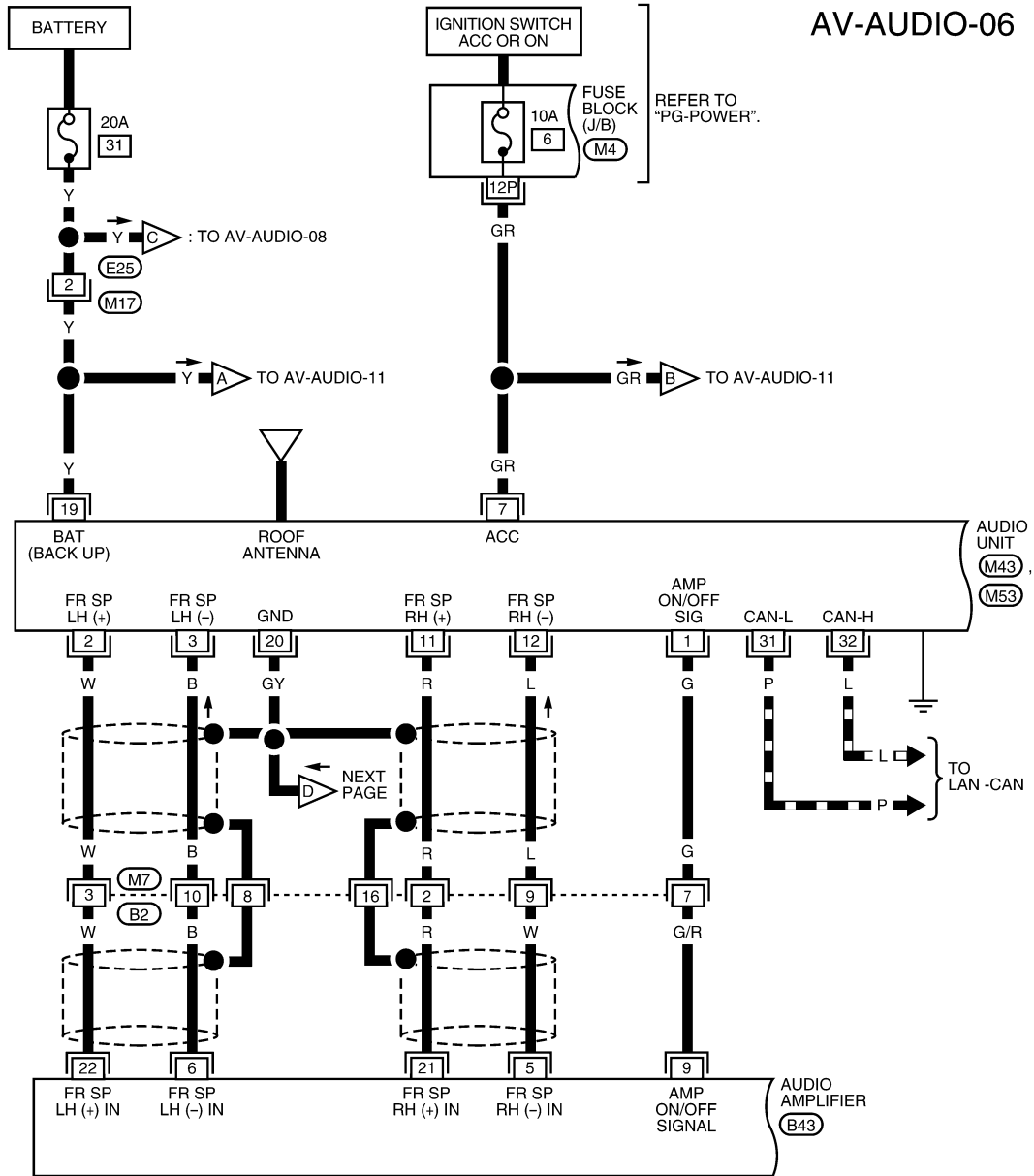

ABNWA0285GE

AUDIO

< SERVICE INFORMATION >

AV-AUDIO-07

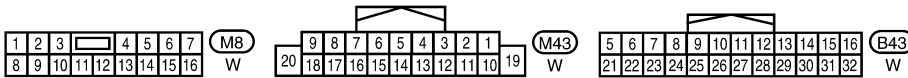
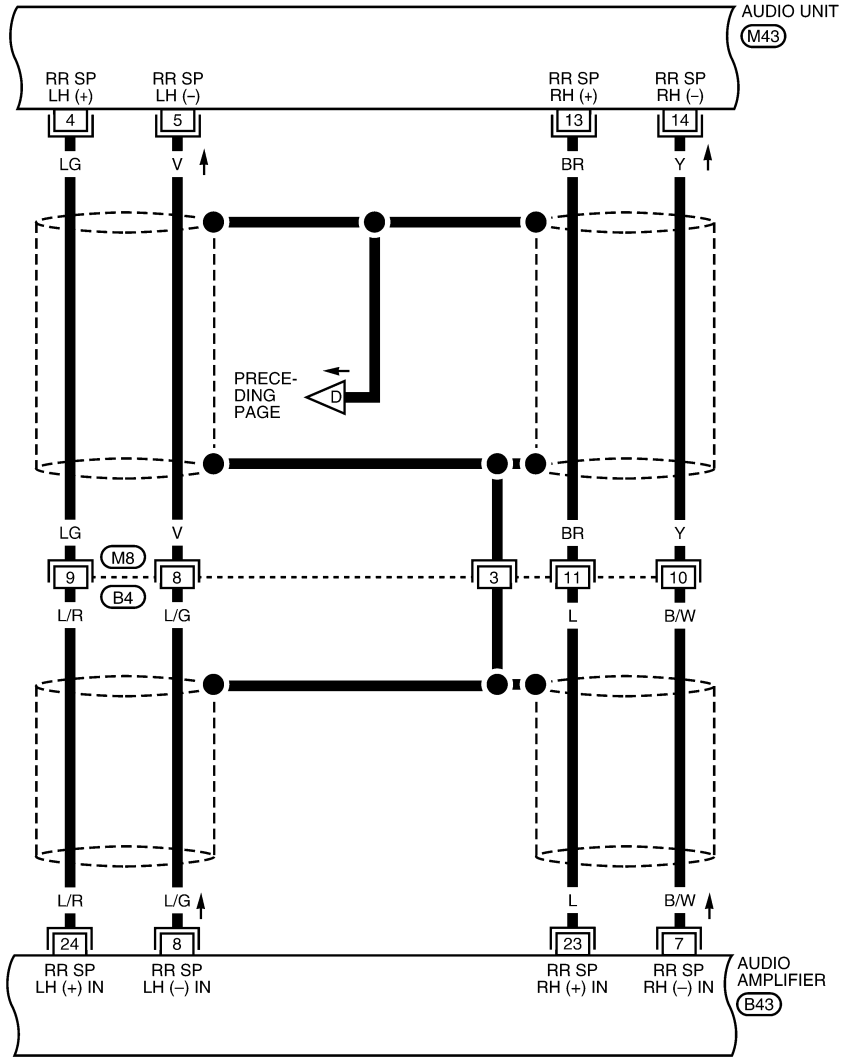

ABNWA0286Gf

AUDIO

< SERVICE INFORMATION >

AV-AUDIO-08

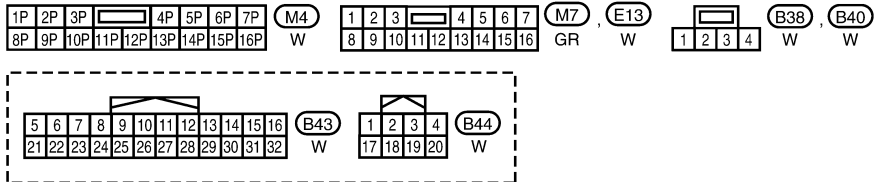
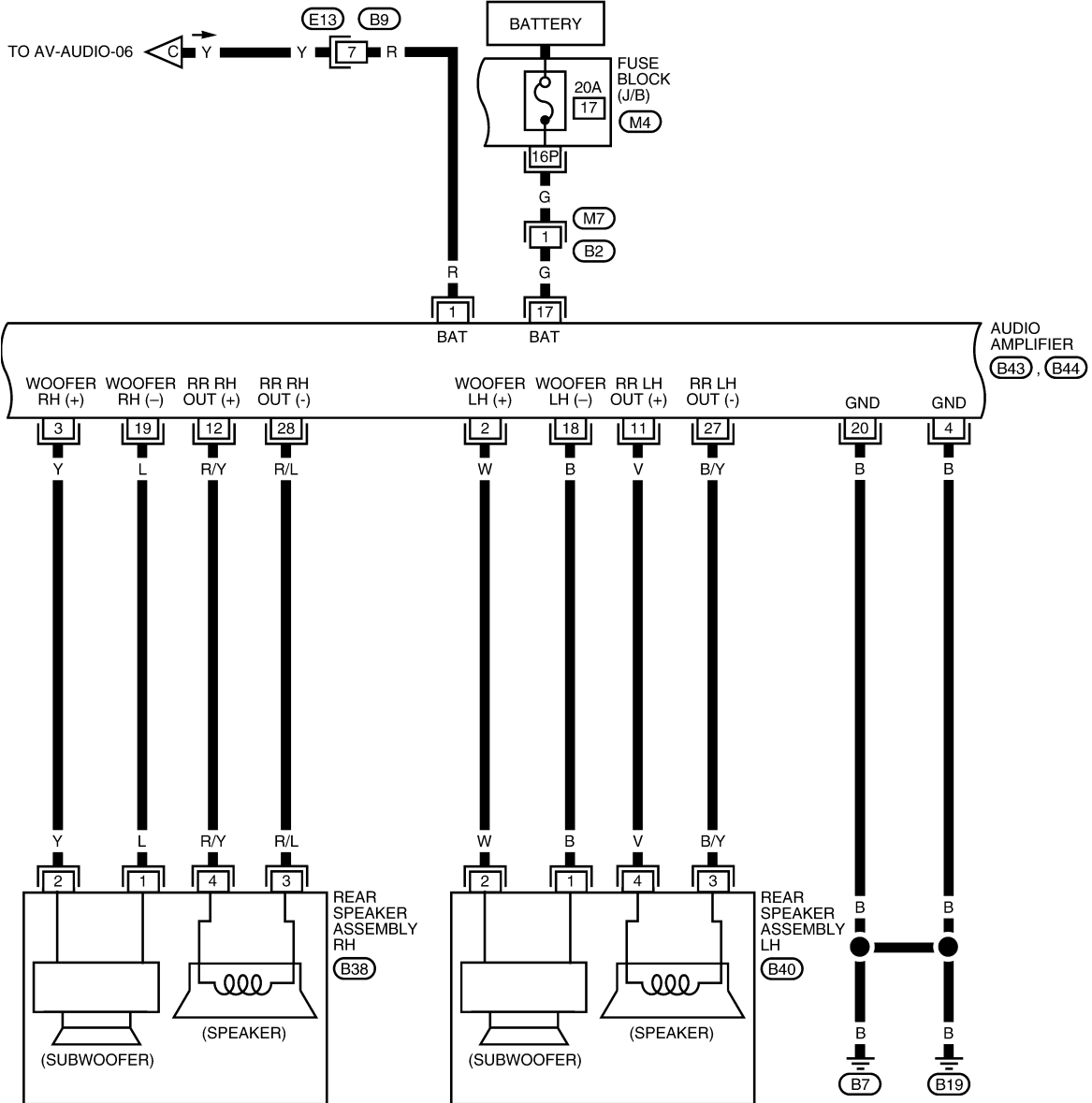

BKWA0765E

A
B
C
D
E
F
G
H
I
J
K
L
M
N
O
P

AV

AUDIO

< SERVICE INFORMATION >

AV-AUDIO-09

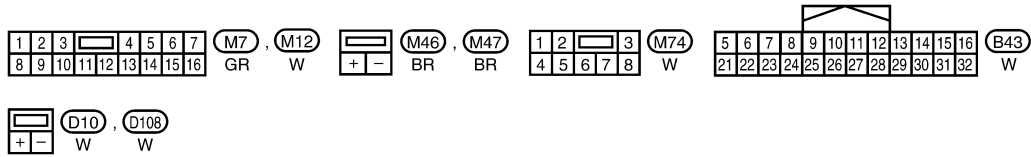
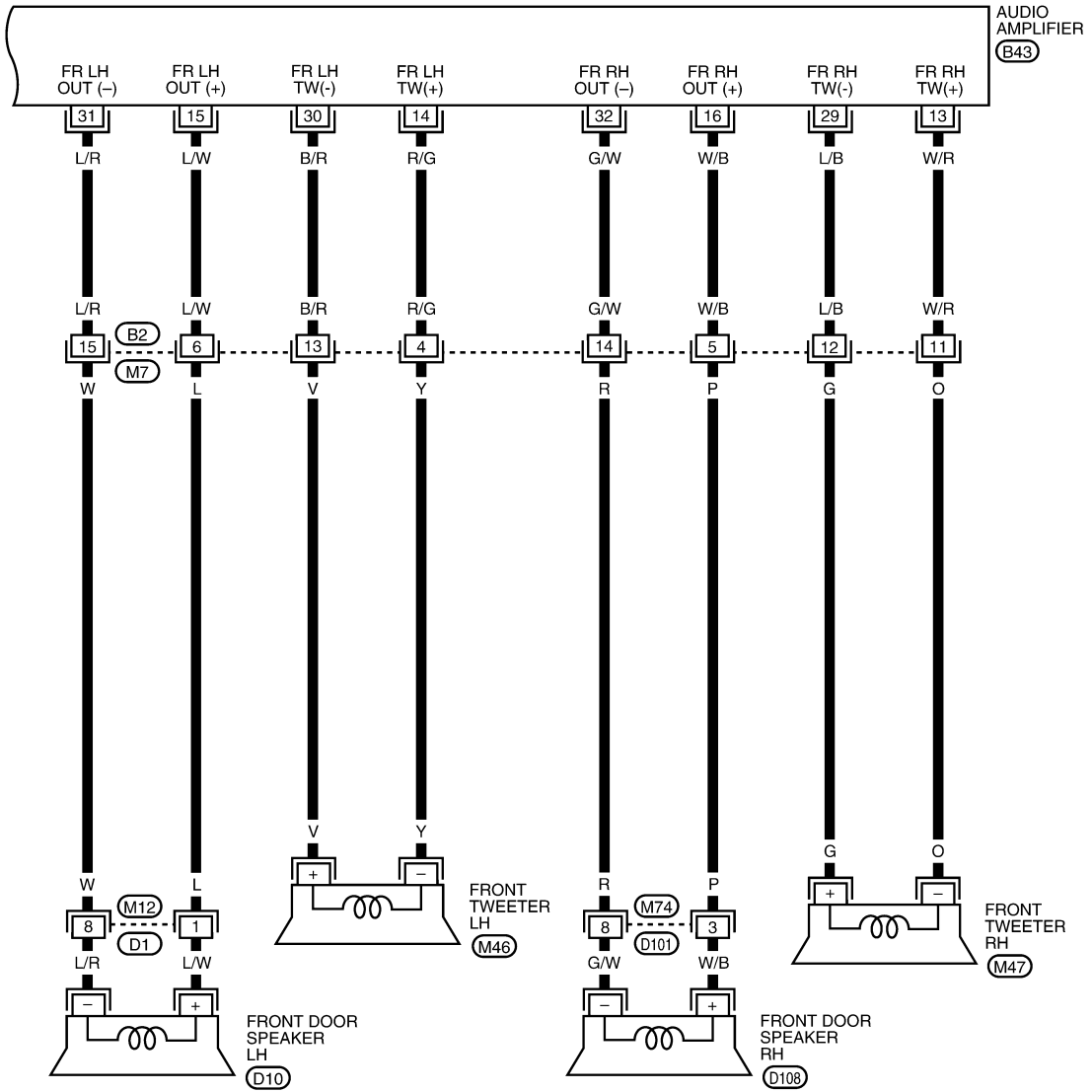

AWKWA0092GI

AUDIO

< SERVICE INFORMATION >

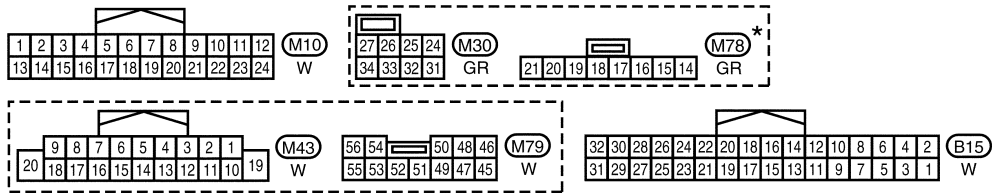
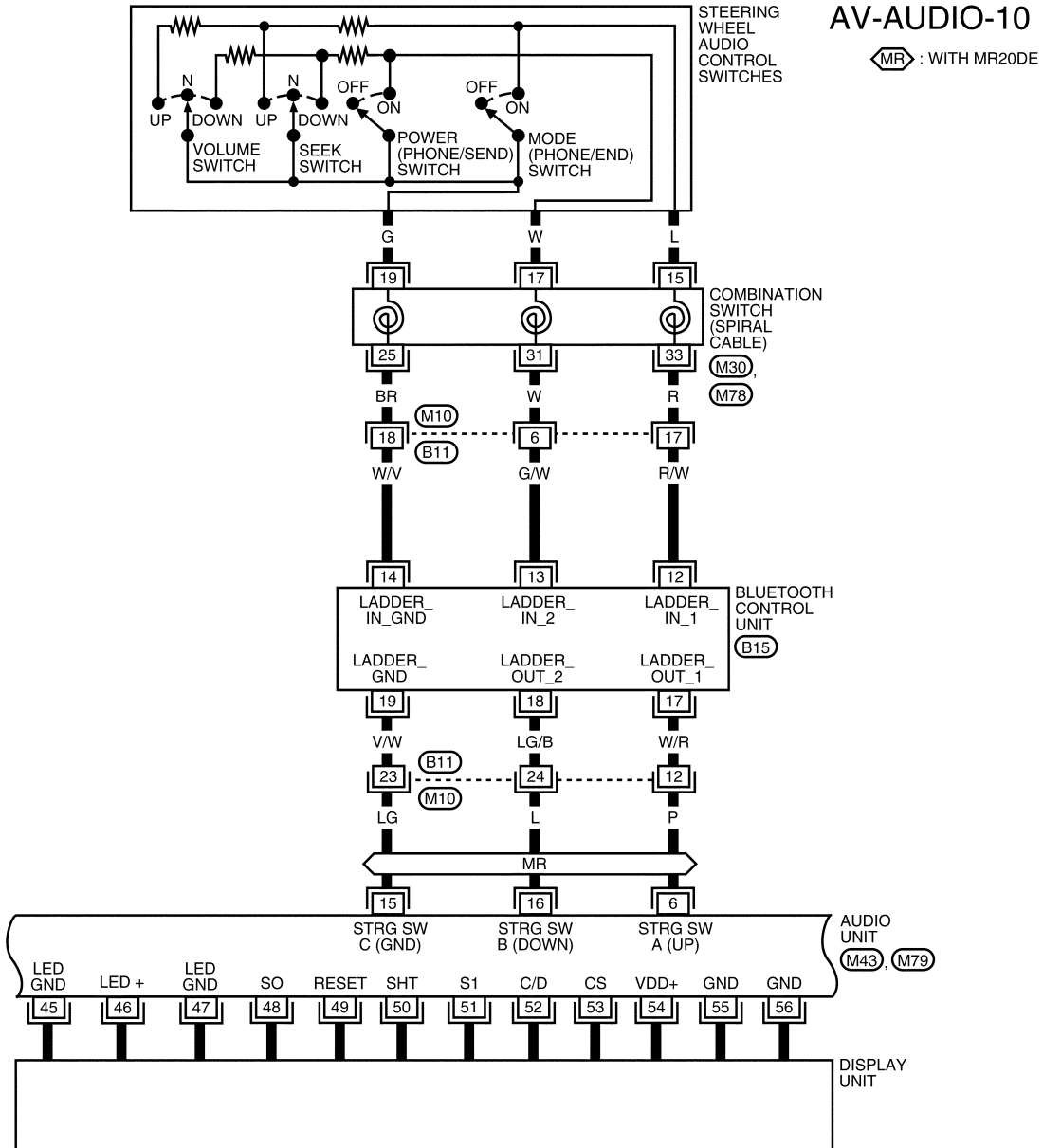

* : THIS CONNECTOR IS NOT SHOWN IN "HARNESS LAYOUT" OF PG SECTION.

WKWA5901E

AUDIO

< SERVICE INFORMATION >

AV-AUDIO-11

ML : WITH MID AUDIO SYSTEM
PA : WITH PREMIUM AUDIO SYSTEM

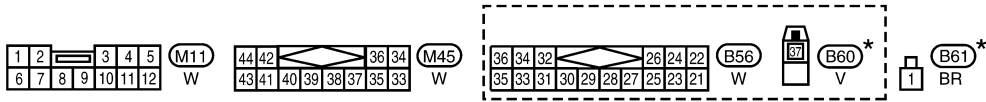
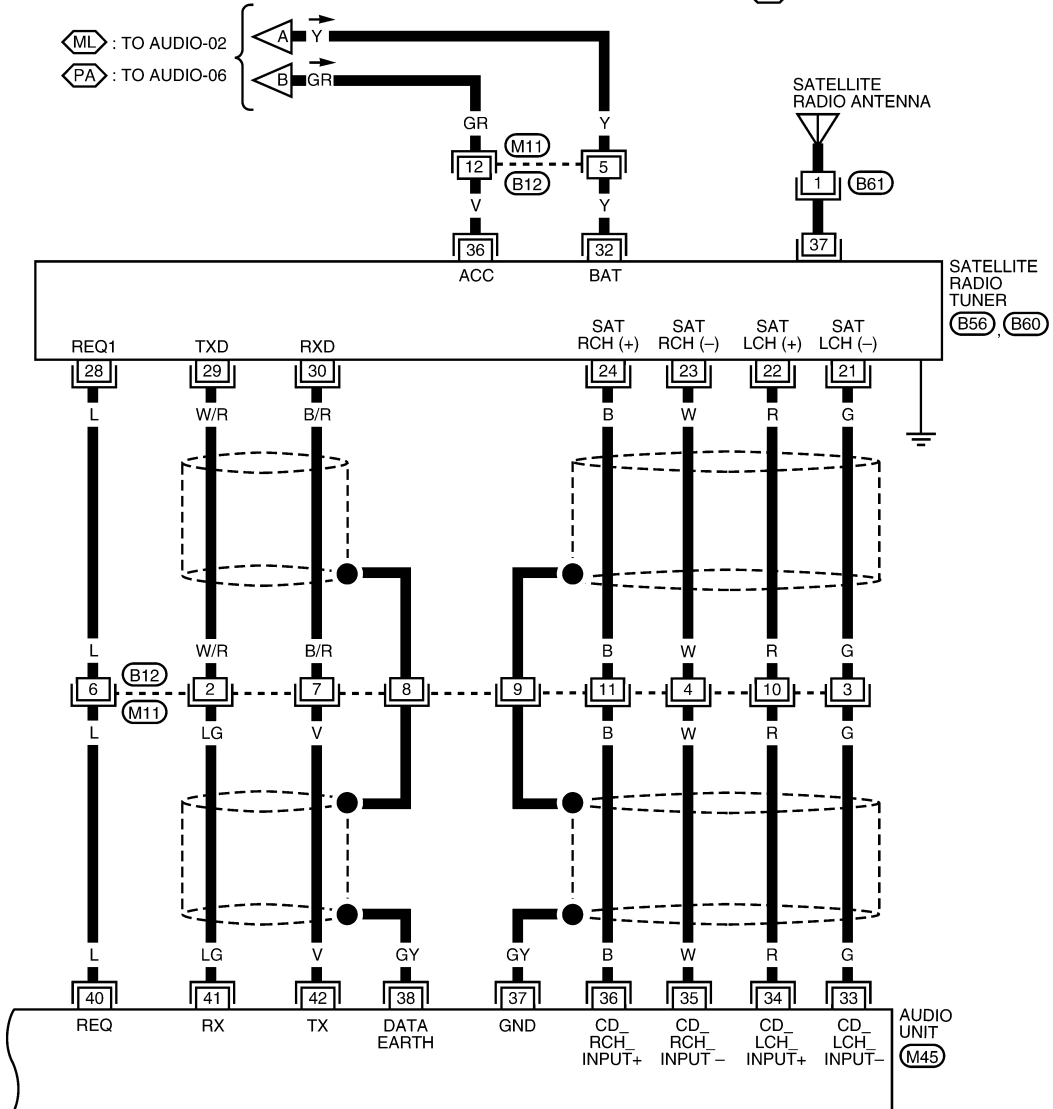

* : THIS CONNECTOR IS NOT SHOWN IN "HARNESS LAYOUT" OF PG SECTION.

AANWA0060GE

AUDIO

< SERVICE INFORMATION >

Audio Unit (Base System) Harness Connector Terminal Layout

INFOID:000000004409424

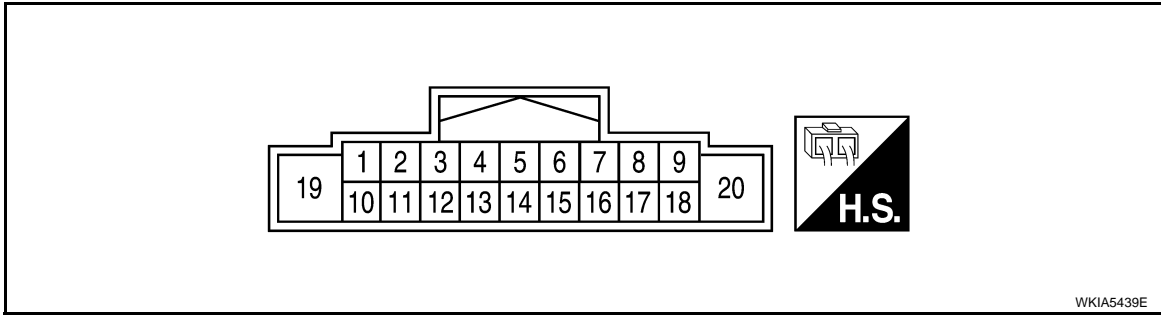

Terminal and Reference Value for Audio Unit (Base System)

INFOID:000000004409424

Terminal (Wire color)		Item	Signal input/ output	Condition		Reference value (Approx.)
+	-			Ignition switch	Operation	
2 (L)	3 (W)	Audio signal front LH	Output	ON	Receive audio signal	<p style="text-align: right; font-size: small;">SKIB3609E</p>
4 (G)	5 (V)	Audio signal rear LH	Output	ON	Receive audio signal	<p style="text-align: right; font-size: small;">SKIB3609E</p>
7 (GR)	Ground	ACC power supply	Input	ACC	-	Battery voltage
11 (P)	12 (R)	Audio signal front RH	Output	ON	Receive audio signal	<p style="text-align: right; font-size: small;">SKIB3609E</p>
13 (L)	14 (Y)	Audio signal rear RH	Output	ON	Receive audio signal	<p style="text-align: right; font-size: small;">SKIB3609E</p>
19 (Y)	Ground	Battery power supply	Input	OFF	-	Battery voltage

A
B
C
D
E
F
G
H
I
J
AV
L
M
N
O
P

AUDIO

< SERVICE INFORMATION >

Audio Unit (Mid System) Harness Connector Terminal Layout

INFOID:000000004409426

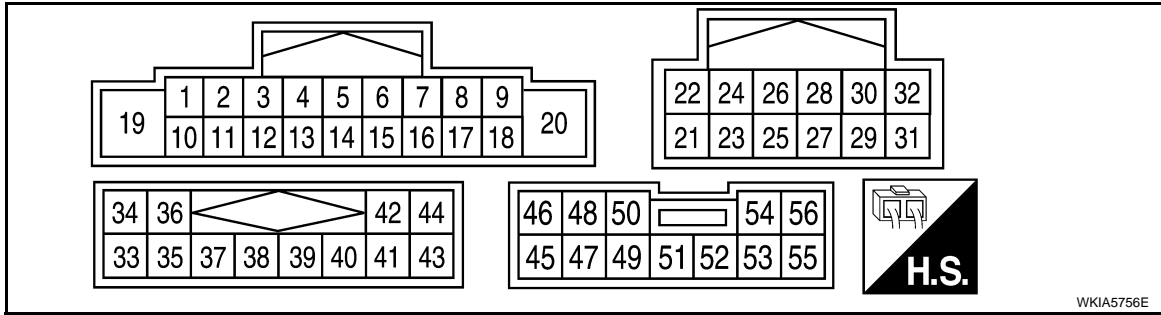

WKIA5756E

Terminal and Reference Value for Audio Unit (Mid System)

INFOID:000000004409426

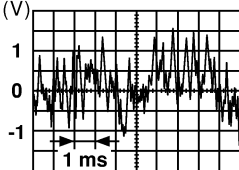
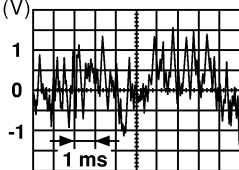
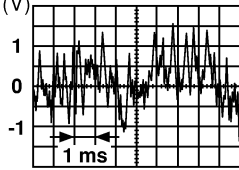
Terminal (Wire color)		Item	Signal input/ output	Condition		Reference value (Approx.)	Example of symp- tom
+	-			Ignition switch	Operation		
2 (L)	3 (W)	Audio sound signal front LH	Output	ON	Receive audio signal	 SKIA0177E	No sound from front door speaker LH or tweeter LH.
4 (G)	5 (V)	Audio sound signal rear LH	Output	ON	Receive audio signal	 SKIA0177E	No sound from rear speaker LH.
6 (P)	Ground	Remote control A	Input	ON	Press Phone/ End switch	0V	Steering wheel au- dio controls do not function
					Press SEEK UP switch	1.7V	
					Press VOL UP switch	3.3V	
					Except for above	5.0V	
7 (GR)	Ground	ACC signal	Input	ON	Ignition switch ACC or ON	Battery voltage	System does not work properly.
11 (P)	12 (R)	Audio sound signal front RH	Output	ON	Receive audio signal	 SKIA0177E	No sound from front door speaker RH or tweeter RH.

AUDIO

< SERVICE INFORMATION >

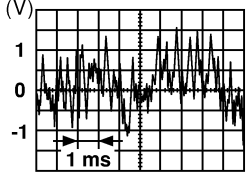
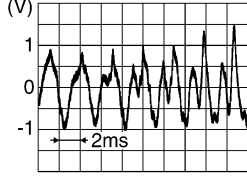
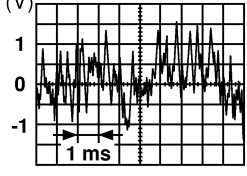
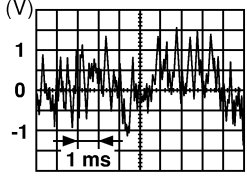
Terminal (Wire color)		Item	Signal input/ output	Condition		Reference value (Approx.)	Example of symp- tom
+	-			Ignition switch	Operation		
13 (L)	14 (Y)	Audio sound signal rear RH	Output	ON	Receive audio signal	 SKIA0177E	No sound from rear speaker RH.
15 (LG)	-	Remote control ground	Input	-	-	-	Steering wheel au- dio controls do not function
16 (L)	Ground	Remote control B	Input	ON	Press Phone/ Send switch	0V	Steering wheel au- dio controls do not function
					Press SEEK DOWN switch	1.7V	
					Press VOL DOWN switch	3.3V	
					Except for above	5.0V	
19 (Y)	Ground	Battery pow- er	Input	-	-	Battery voltage	System does not work properly.
26 (BR)	28 (Y)	Audio in	Input	ACC/ ON	Receive audio signal	 SKIB3609E	Audio can not be heard.
27 (GY)	-	Shield ground	-	-	-	0V	-
30 (R)	-	Mute	Input	-	-	5.0V	Mute inoperative.
31 (P)	-	CAN-L	-	-	-	-	-
32 (L)	-	CAN-H	-	-	-	-	-
34 (R)	33 (G)	Audio left channel sound signal from satel- lite radio tuner	Input	ON	Receive audio signal	 SKIA0177E	No sound from sat- ellite radio tuner left channel.
36 (B)	35 (W)	Audio right channel sound signal from satel- lite radio tuner	Input	ON	Receive audio signal	 SKIA0177E	No sound from sat- ellite radio tuner right channel.
37	-	Shield ground (au- dio signal)	-	-	-	0V	-

A
B
C
D
E
F
G
H
I
J
AV
L
M
N
O
P

AUDIO

< SERVICE INFORMATION >

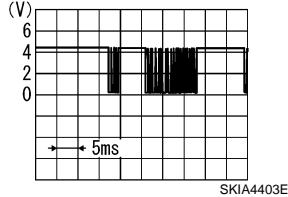
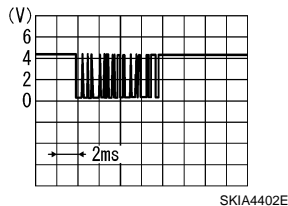
Terminal (Wire color)		Item	Signal input/ output	Condition		Reference value (Approx.)	Example of symp- tom
+	-			Ignition switch	Operation		
38	-	Shield ground (da- ta)	-	-	-	0V	-
40 (L)	Ground	Satellite ra- dio tuner re- quest to audio unit	Input	ON	Turn audio unit ON	5V	Satellite radio tun- er does not oper- ate properly.
41 (LG)	Ground	Audio RX	Input	ON	Receive data		Satellite radio tun- er audio informa- tion does not display properly.
42 (V)	Ground	Audio TX	Output	ON	Transmit data		Satellite radio tun- er audio informa- tion does not display properly.
45	-	LED ground	Input	ON	Audio ON	0V	Display unit will not work.
46	Ground	LED power line	Output	ON	Audio ON	9V	
47	-	LED ground	Input	ON	Audio ON	0V	
48	Ground	Serial output	Output	ON	Audio ON	-	
49	Ground	Reset	Output	ON	Audio ON	5V	
50	Ground	Shift clock	Input	ON	Audio ON	-	
51	Ground	Serial input	Input	ON	Audio ON	-	
52	Ground	Command data	Input	ON	Audio ON	-	
53	Ground	Command data	Input	ON	Audio ON	-	
54	Ground	Display power line	Output	ON	Audio ON	5V	
55	-	Display unit ground	Input	ON	Audio ON/OFF	0V	
56	-	Display unit ground	Input	ON	Audio ON/OFF	0V	

AUDIO

< SERVICE INFORMATION >

Audio Unit (Premium System) Harness Connector Terminal Layout

INFOID:000000004409427

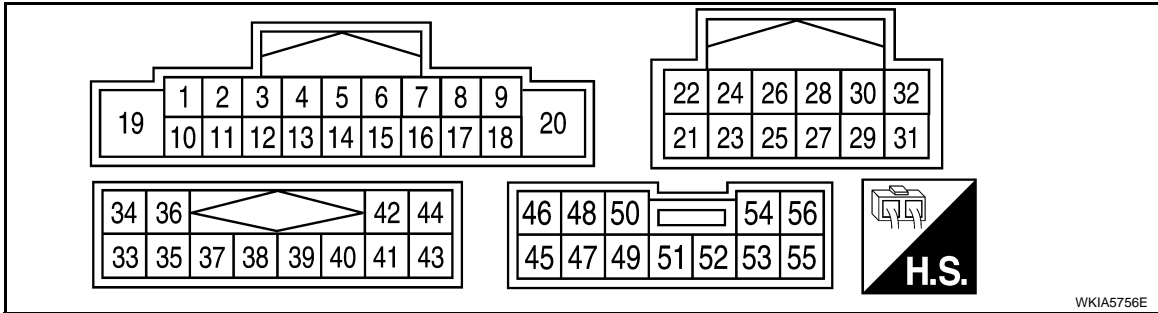

Terminal and Reference Value for Audio Unit (Premium System)

INFOID:000000004409428

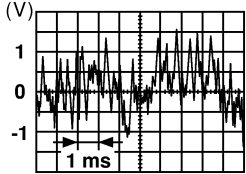
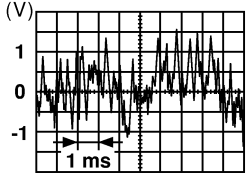
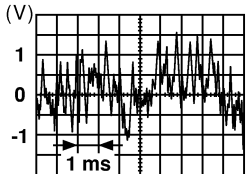
Terminal (Wire color)		Item	Signal input/ output	Condition		Reference value (Approx.)	Example of symp- tom
+	-			Ignition switch	Operation		
1 (G)	Ground	Amp. ON/ OFF signal	Output	ON	-	More than 6.5V	Audio amplifier does not work properly.
2 (W)	3 (B)	Audio sound signal front LH	Output	ON	Receive audio signal	 SKIA0177E	No sound from front door speaker LH or tweeter LH.
4 (LG)	5 (V)	Audio sound signal rear LH	Output	ON	Receive audio signal	 SKIA0177E	No sound from rear speaker as- sembly LH.
6 (P)	Ground	Remote control A	Input	ON	Press Phone/ End switch	0V	Steering wheel au- dio controls do not function
					Press SEEK UP switch	1.7V	
					Press VOL UP switch	3.3V	
					Except for above	5.0V	
7 (GR)	Ground	ACC signal	Input	ON	Ignition switch ACC or ON	Battery voltage	System does not work properly.
11 (R)	12 (L)	Audio sound signal front RH	Output	ON	Receive audio signal	 SKIA0177E	No sound from front door speaker RH or tweeter RH.

AUDIO

< SERVICE INFORMATION >

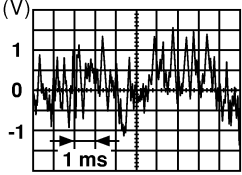
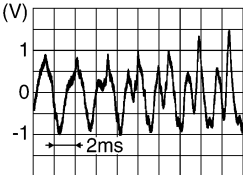
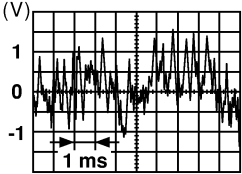
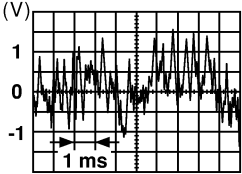
Terminal (Wire color)		Item	Signal input/ output	Condition		Reference value (Approx.)	Example of symp- tom
+	-			Ignition switch	Operation		
13 (BR)	14 (Y)	Audio sound signal rear RH	Output	ON	Receive audio signal	 SKIA0177E	No sound from rear speaker as- sembly RH.
15 (LG)	-	Remote control ground	Input	-	-	-	Steering wheel au- dio controls do not function
16 (L)	Ground	Remote control B	Input	ON	Press Phone/ Send switch	0V	Steering wheel au- dio controls do not function
					Press SEEK DOWN switch	1.7V	
					Press VOL DOWN switch	3.3V	
					Except for above	5.0V	
19 (Y)	Ground	Battery pow- er	Input	-	-	Battery voltage	System does not work properly.
20 (GY)	-	Shield ground	-	-	-	-	-
26 (BR)	28 (Y)	Audio in	Input	ACC/ ON	Receive audio signal	 SKIB3609E	Audio can not be heard.
27 (GY)	-	Shield ground	-	-	-	0V	-
30 (R)	-	Mute	Input	-	-	5.0V	Mute inoperative.
31 (P)	-	CAN-L	-	-	-	-	-
32 (L)	-	CAN-H	-	-	-	-	-
34 (R)	33 (G)	Audio left channel sound signal from satel- lite radio tuner	Input	ON	Receive audio signal	 SKIA0177E	No sound from sat- ellite radio tuner left channel.
36 (B)	35 (W)	Audio right channel sound signal from satel- lite radio tuner	Input	ON	Receive audio signal	 SKIA0177E	No sound from sat- ellite radio tuner right channel.

AUDIO

< SERVICE INFORMATION >

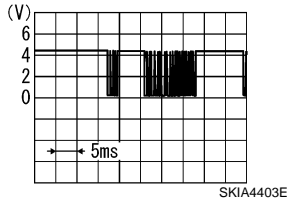
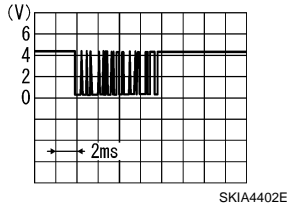
Terminal (Wire color)		Item	Signal input/ output	Condition		Reference value (Approx.)	Example of symp- tom
+	-			Ignition switch	Operation		
37 (GY)	-	Shield ground (au- dio signal)	-	-	-	0V	-
38 (GY)	-	Shield ground (da- ta)	-	-	-	0V	-
40 (L)	Ground	Satellite ra- dio tuner re- quest to audio unit	Input	ON	Turn audio unit ON	5V	Satellite radio tun- er does not oper- ate properly.
41 (LG)	Ground	Audio RX	Input	ON	Receive data		Satellite radio tun- er audio informa- tion does not display properly.
42 (V)	Ground	Audio TX	Output	ON	Transmit data		Satellite radio tun- er audio informa- tion does not display properly.
45	-	LED ground	Input	ON	Audio ON	0V	Display unit will not work.
46	Ground	LED power line	Output	ON	Audio ON	9V	
47	-	LED ground	Input	ON	Audio ON	0V	
48	Ground	Serial output	Output	ON	Audio ON	-	
49	Ground	Reset	Output	ON	Audio ON	5V	
50	Ground	Shift clock	Input	ON	Audio ON	-	
51	Ground	Serial input	Input	ON	Audio ON	-	
52	Ground	Command data	Input	ON	Audio ON	-	
53	Ground	Command data	Input	ON	Audio ON	-	
54	Ground	Display power line	Output	ON	Audio ON	5V	
55	-	Display unit ground	Input	ON	Audio ON/OFF	0V	
56	-	Display unit ground	Input	ON	Audio ON/OFF	0V	

A
B
C
D
E
F
G
H
I
J
L
M
N
O
P

AV

AUDIO

< SERVICE INFORMATION >

Audio Amplifier Harness Connector Terminal Layout (Premium System)

INFOID:000000004409429

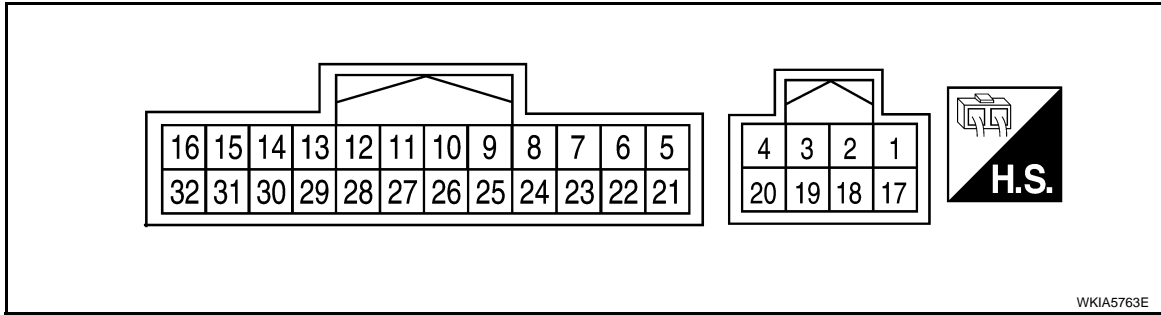

Terminal and Reference Value for Audio Amplifier (Premium System)

INFOID:000000004409430

Terminal (wire color)		Item	Signal input/output	Condition		Reference value (Approx.)	Example of symptom
+	-			Ignition switch	Operation		
1 (R)	Ground	Battery	Input	-	-	Battery voltage	System does not work properly.
2 (W)	18 (B)	Subwoofer LH	Output	ON	Receive audio signal	 SKIA0177E	No sound from subwoofer LH.
3 (Y)	19 (L)	Subwoofer RH	Output	ON	Receive audio signal	 SKIA0177E	No sound from subwoofer RH.
4 (B)	Ground	Ground	-	ON	-	-	-
9 (G/R)	Ground	Amp. ON signal	Input	ON	-	More than 6.5V	System does not work properly.
11 (V)	27 (B/Y)	Rear speaker LH	Output	ON	Receive audio signal	 SKIA0177E	No sound from rear speaker LH.
12 (R/Y)	28 (R/L)	Rear speaker RH	Output	ON	Receive audio signal	 SKIA0177E	No sound from rear speaker RH.

AUDIO

< SERVICE INFORMATION >

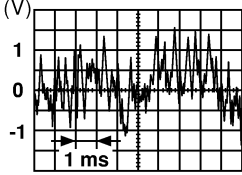
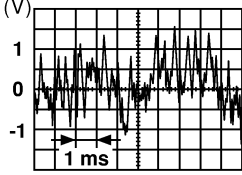
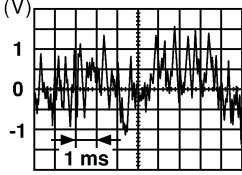
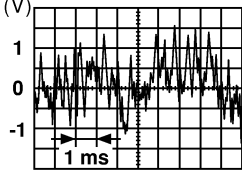
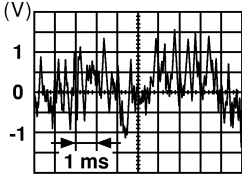
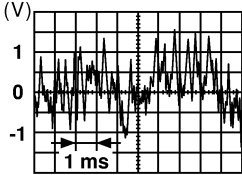
Terminal (wire color)		Item	Signal input/ output	Condition		Reference value (Approx.)	Example of symptom
+	-			Ignition switch	Operation		
13 (W/R)	29 (L/B)	Front tweeter RH	Output	ON	Receive audio signal	 SKIA0177E	No sound from front tweeter RH.
14 (R/G)	30 (B/R)	Front tweeter LH	Output	ON	Receive audio signal	 SKIA0177E	No sound from front tweeter LH.
15 (L/W)	31 (L/R)	Front door speaker LH	Output	ON	Receive audio signal	 SKIA0177E	No sound from front door speaker LH.
16 (W/B)	32 (G/W)	Front door speaker RH	Output	ON	Receive audio signal	 SKIA0177E	No sound from front door speaker RH.
17 (G)	Ground	Battery	Input	-	-	Battery voltage	System does not work properly.
20 (B)	Ground	Ground	-	ON	-	-	-
21 (R)	5 (W)	Audio sound signal front RH	Input	ON	Receive audio signal	 SKIA0177E	No sound from front door speaker RH or front tweeter RH.
22 (W)	6 (B)	Audio sound signal front LH	Input	ON	Receive audio signal	 SKIA0177E	No sound from front door speaker LH or front tweeter LH.

A
B
C
D
E
F
G
H
I
J
L
M
N
O
P

AV

AUDIO

< SERVICE INFORMATION >

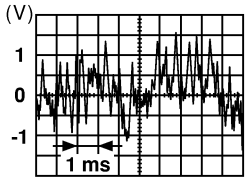
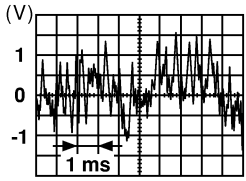
Terminal (wire color)		Item	Signal input/output	Condition		Reference value (Approx.)	Example of symptom
+	-			Ignition switch	Operation		
23 (L)	7 (B/W)	Audio sound signal rear RH	Input	ON	Receive audio signal	 SKIA0177E	No sound from rear speaker assembly RH.
24 (L/R)	8 (L/G)	Audio sound signal rear LH	Input	ON	Receive audio signal	 SKIA0177E	No sound from rear speaker assembly LH.

Satellite Radio Tuner Harness Connector Terminal Layout

INFOID:000000004409431

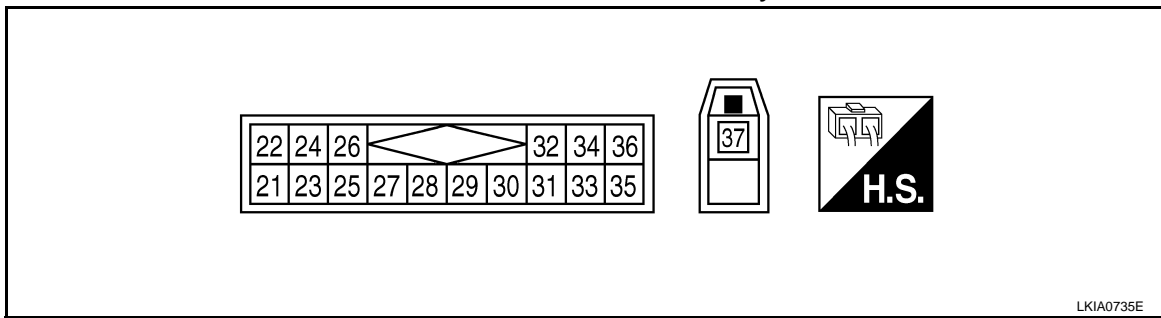

Terminal and Reference Value for Satellite Radio Tuner

INFOID:000000004409432

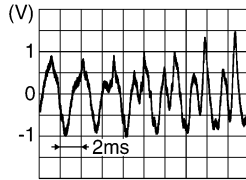
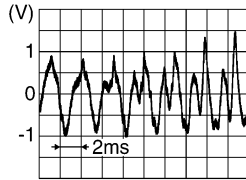
Terminal (Wire color)		Item	Signal input/output	Condition		Voltage (Approx.)
+	-			Ignition switch	Operation	
22 (R)	21 (G)	Audio signal LH	Output	ON	Receive audio signal.	 SKIB3609E
24 (B)	23 (W)	Audio signal RH	Output	ON	Receive audio signal.	 SKIB3609E

AUDIO

< SERVICE INFORMATION >

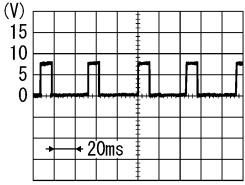
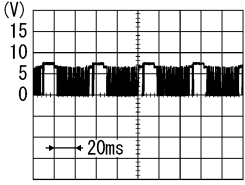
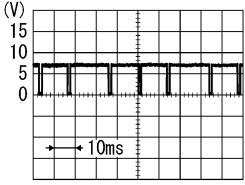
Terminal (Wire color)		Item	Signal input/ output	Condition		Voltage (Approx.)
+	-			Ignition switch	Operation	
28 (L)	Ground	REQ1 (SAT-AUDIO)	Output	ON	Set to the satellite radio mode	 <small>SKIB3825E</small>
29 (W/R)	Ground	Communication signal (SAT-AUDIO)	Output	ON	Set to the satellite radio mode	 <small>SKIB3824E</small>
30 (B/R)	Ground	Communication signal (AUDIO-SAT)	Input	ON	Set to the satellite radio mode	 <small>SKIB3826E</small>
32 (Y)	Ground	Battery power supply	Input	OFF	-	Battery voltage
36 (V)		ACC power supply		ACC		
37		Antenna signal		-		

Audio Unit Self-Diagnosis Function (Base System)

INFOID:000000004409433

1. Turn ignition switch to ACC position.
2. Turn the audio system off.
3. While pressing the "RPT-SCAN" button, turn the volume control dial clockwise or counterclockwise 30 clicks or more. When the self-diagnosis mode is started, a short beep will be heard.

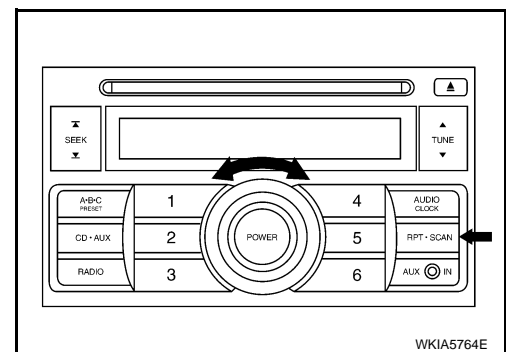

AUDIO

< SERVICE INFORMATION >

- When the self-diagnosis mode is started, all of the display segments will be illuminated.

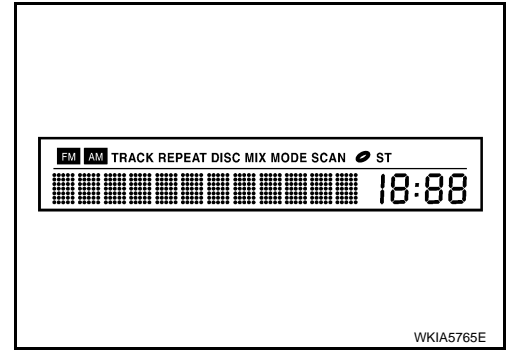

VERSION CHECK

- Press the "AUDIO/CLOCK" switch to enter version diagnostics. "S/W VER" (audio software version) is displayed.



- Press the "AUDIO/CLOCK" switch again to display the "H/W VER" (audio hardware version).



- Press the "AUDIO/CLOCK" switch again to display the "CDM VER" (CD mechanism version).



CHANNEL CHECK DIAGNOSTICS

AUDIO

< SERVICE INFORMATION >

When all segments are illuminated, press the "TUNE" down switch to enter channel check diagnostics. The self-diagnostic function will then send a tone to each channel (FL, RL, RR, FR) for 1 second.

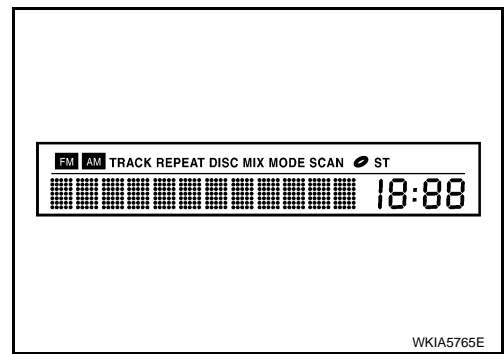

BUTTON CHECK DIAGNOSTICS

When all segments are illuminated, a tone will sound while pressing each individual switch.

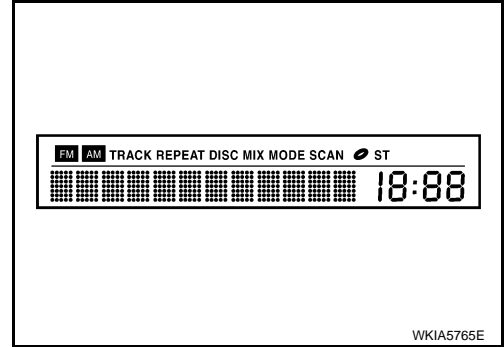

Audio Unit Self-Diagnosis Function (Mid and Premium System)

INFOID:000000004409434

Refer to [AV-82, "On Board Self-Diagnosis Function"](#).

Trouble Diagnosis

INFOID:000000004409435

The majority of the audio troubles are the result of outside causes (bad CD, electromagnetic interference, etc.). Check the inspection items below to diagnose the malfunction.

MALFUNCTION WITH RADIO AND CD (BASE AND MID SYSTEM)

Symptom	Possible cause
Inoperative	<ul style="list-style-type: none"> Audio unit power supply circuit check. Refer to AV-35, "Power Supply Circuit Inspection". If above check is OK, replace audio unit. Refer to AV-51, "Removal and Installation".
Steering switch does not operate (MR20DE models with mid system)	<ul style="list-style-type: none"> Steering switch check. Refer to AV-40, "Steering Switch Check (With Bluetooth)" or AV-42, "Steering Switch Check (Without Bluetooth)". If above check is OK, replace audio unit. Refer to AV-51, "Removal and Installation".
All speakers do not sound	<ul style="list-style-type: none"> Audio unit
One or several speakers do not sound	<ul style="list-style-type: none"> Front door speaker check. Refer to AV-43, "Sound Is Not Heard from Front Door Speaker or Front Tweeter (Base and Mid System)". Rear speaker check. Refer to AV-44, "Sound Is Not Heard from Rear Speaker (Base and Mid System)".
Poor sound	<ul style="list-style-type: none"> Audio unit Speaker
Noisy	<ul style="list-style-type: none"> Audio unit Electrical equipment (generator, bonding wire, etc.)

MALFUNCTION WITH RADIO AND CD (PREMIUM SYSTEM)

AUDIO

< SERVICE INFORMATION >

Symptom	Possible cause
Inoperative	<ul style="list-style-type: none"> • Audio unit power supply circuit check. Refer to AV-35, "Power Supply Circuit Inspection". If above check is OK, replace audio unit. Refer to AV-51, "Removal and Installation" .
Steering switch does not operate (MR20DE models)	<ul style="list-style-type: none"> • Steering switch check. Refer to AV-40, "Steering Switch Check (With Bluetooth)". If above check is OK, replace audio unit. Refer to AV-51, "Removal and Installation" .
All speakers do not sound	<ul style="list-style-type: none"> • Audio unit • Audio amplifier power supply and ground circuit check. Refer to AV-35, "Power Supply Circuit Inspection". • Audio amplifier ON signal • Audio amplifier
One or several speakers do not sound	<ul style="list-style-type: none"> • Front door speaker check. Refer to AV-46, "Sound Is Not Heard from Front Door Speaker or Front Tweeter (Premium System)". • Rear speaker check. Refer to AV-48, "Sound Is Not Heard from Rear Speaker Assembly (Premium System)".
Poor sound	<ul style="list-style-type: none"> • Audio unit • Audio amplifier • Speaker
Noisy	<ul style="list-style-type: none"> • Audio unit • Audio amplifier • Electrical equipment (generator, bonding wire, etc.)

FOR RADIO ONLY

Symptom	Possible cause
No sound	<ul style="list-style-type: none"> • Audio unit • Antenna feeder, wiring or connections
Noisy	<ul style="list-style-type: none"> • Audio unit • Audio unit case ground • Antenna feeder, wiring or connections • Noise prevention parts • Electrical equipment • Wire harness of each piece of electrical equipment
All radio stations stored in memory are deleted	<ul style="list-style-type: none"> • Audio unit power supply circuit. Refer to AV-35, "Power Supply Circuit Inspection". • Audio unit

NOTE:

The following noise results from variations in field strength, such as fading noise and multi-path noise, or external noise from trains and other sources. It is not a malfunction.

- Fading noise: This noise occurs because of variations in the field strength in a narrow range due to mountains or buildings blocking the signal.
- Multi-path noise: This noise results from the waves sent directly from the broadcast station arriving at the antenna at a different time from the waves which reflect off mountains or buildings.

FOR CD ONLY

Symptom	Possible cause
CD cannot be inserted.	<ul style="list-style-type: none"> • CD • Audio unit
CD cannot be ejected.	
The CD cannot be played.	
The sound skips, stops suddenly, or is distorted.	

FOR SATELLITE RADIO TUNER ONLY

AUDIO

< SERVICE INFORMATION >

Symptom	Possible cause
Inoperative	<ul style="list-style-type: none"> Satellite radio tuner power and ground circuit inspection. Refer to AV-37, "Satellite Radio Tuner Power and Ground Supply Circuit Inspection". Satellite radio tuner communication circuit inspection. Refer to AV-37, "Satellite Radio Tuner Communication Circuit Inspection". <p>If above check is OK, replace satellite radio tuner. Refer to AV-51, "Removal and Installation".</p>
Right or left channel does not sound	<ul style="list-style-type: none"> Satellite radio tuner right channel audio signal circuit inspection. Refer to AV-40, "Satellite Radio Tuner Right Channel Audio Signal Circuit Inspection". Satellite radio tuner left channel audio signal circuit inspection. Refer to AV-39, "Satellite Radio Tuner Left Channel Audio Signal Circuit Inspection". <p>If above check is OK, replace satellite radio tuner. Refer to AV-51, "Removal and Installation".</p>
Poor reception	<ul style="list-style-type: none"> Location of vehicle. Make certain vehicle is in an open area. Satellite radio antenna or antenna feeder. Refer to AV-56, "Location of Antenna".
Noisy	<ul style="list-style-type: none"> Satellite radio tuner ground. Satellite radio tuner harness shield wires. Electrical equipment (generator, bonding wire, etc.). Refer to AV-35, "Noise Inspection".

Noise Inspection

INFOID:000000004409436

The vehicle itself can be a source of noise if noise prevention parts or electrical equipment is malfunctioning. Check if noise is caused and/or changed by engine speed, ignition switch turned to each position, and operation of each piece of electrical equipment, and determine the cause.

NOTE:

The source of the noise can be found easily by listening to the noise while removing the fuses of electrical components, one by one.

TYPE OF NOISE AND POSSIBLE CAUSE

Occurrence condition	Possible cause	
Occurs only when engine is ON.	A continuous growling noise occurs. The speed of the noise varies with changes in the engine speed.	Ignition components
	A whistling noise occurs while the engine speed is high. A booming noise occurs while the engine is running and the lighting switch is ON.	Generator
Noise only occurs when various electrical components are operating.	A cracking or snapping sound occurs with the operation of various switches.	Relay malfunction, radio malfunction
	The noise occurs when various motors are operating.	<ul style="list-style-type: none"> Motor case ground Motor
The noise occurs constantly, not just under certain conditions.	<ul style="list-style-type: none"> Rear defogger coil malfunction Open circuit in printed heater 	
A cracking or snapping sound occurs while the vehicle is being driven, especially when it is vibrating excessively.	<ul style="list-style-type: none"> Ground wire of body parts. Ground due to improper part installation Wiring connections or a short circuit 	

Power Supply Circuit Inspection

INFOID:000000004409437

1.CHECK FUSE

Check that the following fuses of the audio amplifier (premium system) and audio unit are not blown.

Unit	Terminals	Signal name	Fuse No.
Audio unit	19	Battery power	31
	7	Ignition switch ACC or ON	6

AUDIO

< SERVICE INFORMATION >

Unit	Terminals	Signal name	Fuse No.
Audio amplifier (premium system)	17	Battery power	17
	1	Battery power	31

OK or NG

OK >> GO TO 2.

NG >> If fuse is blown, be sure to eliminate cause of malfunction before installing new fuse. Refer to [PG-3](#).

2. AUDIO UNIT POWER SUPPLY CIRCUIT CHECK

1. Disconnect audio unit connector.
2. Check voltage between the audio unit and ground.

Unit	Terminal No.		OFF	ACC	ON	
	(+)					(-)
	Connector	Terminal				
Audio unit	M43	19	Battery voltage	Battery voltage	Battery voltage	
		7	0V	Battery voltage	Battery voltage	

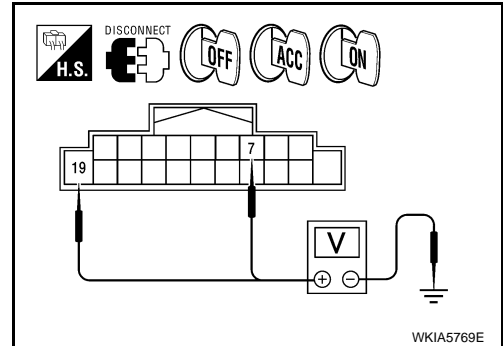

OK or NG

OK >> With premium system, GO TO 3.

NG >> • Check connector housings for disconnected or loose terminals.
• Repair harness or connector.

3. AUDIO AMPLIFIER (PREMIUM SYSTEM) POWER SUPPLY CIRCUIT CHECK

1. Disconnect audio amplifier connector.
2. Check voltage between audio amplifier and ground.

Unit	Terminal No.		OFF	ACC	ON	
	(+)					(-)
	Connector	Terminal				
Audio amplifier	B44	1	0V	Battery voltage	Battery voltage	
		17				

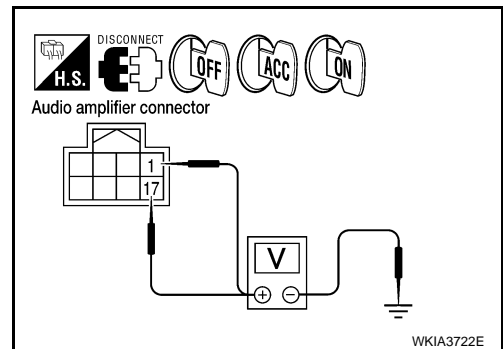

OK or NG

OK >> GO TO 4.

NG >> • Check connector housings for disconnected or loose terminals.
• Repair harness or connector.

4. GROUND CIRCUIT CHECK

Check continuity between audio amplifier harness connector B44 terminals 4, 20 and ground.

Continuity should exist.

OK or NG

OK >> Inspection End.

NG >> • Check connector housings for disconnected or loose terminals.
• Repair harness or connector.

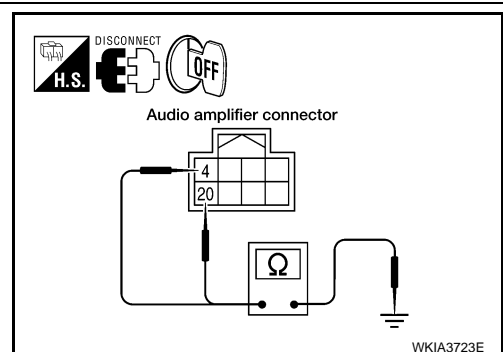

AUDIO

< SERVICE INFORMATION >

Satellite Radio Tuner Power and Ground Supply Circuit Inspection

INFOID:000000004409438

1. CHECK FUSES

Check that the following fuses are not blown.

Unit	Terminals	Signal name	Fuse No.
Satellite radio tuner	32	Battery power	31
	36	Ignition switch ACC or ON	6

OK or NG

OK >> GO TO 2.

NG >> If fuse is blown, be sure to eliminate cause of malfunction before installing new fuse. Refer to [PG-3](#).

2. POWER SUPPLY CIRCUIT CHECK

- Turn ignition switch OFF.
- Disconnect satellite radio tuner connector B56.
- Check voltage between the satellite radio tuner and ground.

Unit	Terminal No.		OFF	ACC	ON
	(+)				
	Connector	Terminal			
Satellite radio tuner	B56	32	Ground	Battery voltage	Battery voltage
		36	Ground	0V	Battery voltage

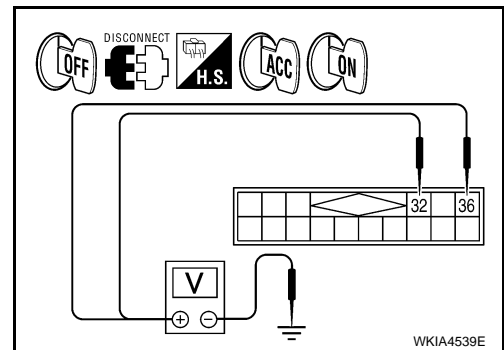

OK or NG

OK >> GO TO 3.

NG >> • Check connector housings for disconnected or loose terminals.
• Repair harness or connector.

3. GROUND CIRCUIT CHECK

Inspect satellite radio tuner case ground.

OK or NG

OK >> Inspection End.

NG >> Repair satellite radio tuner case ground.

Satellite Radio Tuner Communication Circuit Inspection

INFOID:000000004409439

1. CHECK HARNESS - 1

- Turn ignition switch OFF.
- Disconnect satellite radio tuner connector B56 and audio unit connector M45.
- Check continuity between satellite radio tuner harness connector B56 (A) terminal 28 and audio unit harness connector M45 (B) terminal 40.

Continuity should exist.

- Check continuity between satellite radio tuner harness connector B56 (A) terminal 28 and ground.

Continuity should not exist.

OK or NG

OK >> GO TO 2.

NG >> Repair harness or connector.

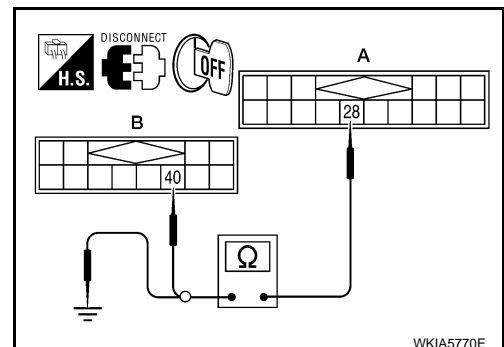

AUDIO

< SERVICE INFORMATION >

2. CHECK HARNESS - 2

1. Check continuity between satellite radio tuner harness connector B56 (A) terminal 29 and audio unit harness connector M45 (B) terminal 41.

Continuity should exist.

2. Check continuity between satellite radio tuner harness connector B56 (A) terminal 29 and ground.

Continuity should not exist.

OK or NG

OK >> GO TO 3.

NG >> Repair harness or connector.

3. CHECK HARNESS - 3

1. Check continuity between satellite radio tuner harness connector B56 (A) terminal 30 and audio unit harness connector M45 (B) terminal 42.

Continuity should exist.

2. Check continuity between satellite radio tuner harness connector B56 (A) terminal 30 and ground.

Continuity should not exist.

OK or NG

OK >> GO TO 4.

NG >> Repair harness or connector.

4. CHECK REQ1 SIGNAL

1. Connect satellite radio tuner connector and audio unit connector.
2. Turn ignition switch to ACC.
3. Check signal between satellite radio tuner harness connector B56 terminal 28 and ground with CONSULT-III or oscilloscope.

28 - Ground : Refer to [AV-30, "Terminal and Reference Value for Satellite Radio Tuner"](#).

OK or NG

OK >> GO TO 5.

NG >> Replace audio unit. Refer to [AV-51, "Removal and Installation"](#).

5. CHECK TXD SIGNAL

Check signal between satellite radio tuner harness connector B56 terminal 29 and ground with CONSULT-III or oscilloscope.

29 - Ground : Refer to [AV-30, "Terminal and Reference Value for Satellite Radio Tuner"](#).

OK or NG

OK >> GO TO 6.

NG >> Replace audio unit. Refer to [AV-51, "Removal and Installation"](#).

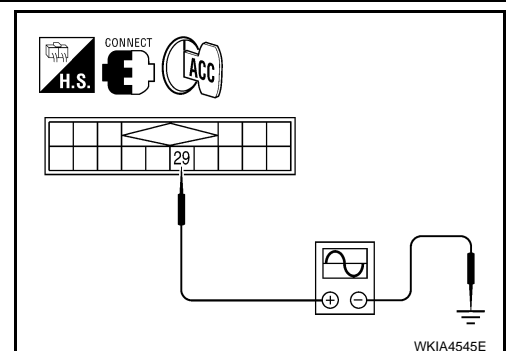
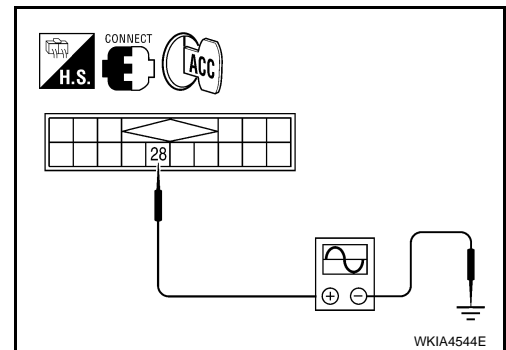
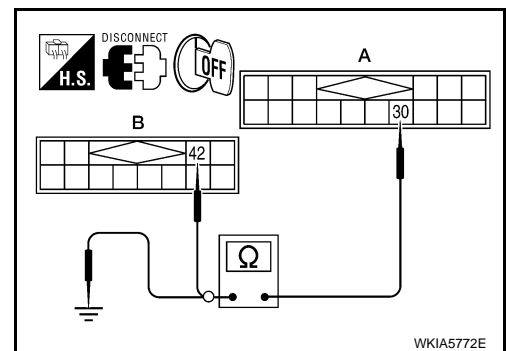
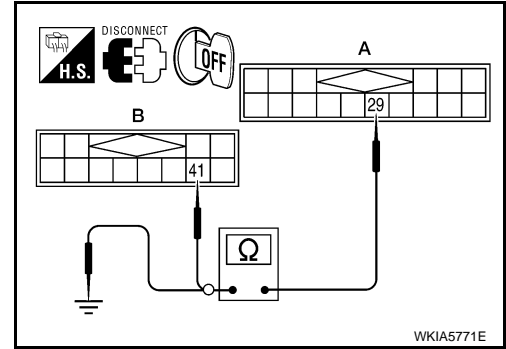

AUDIO

< SERVICE INFORMATION >

6. CHECK RXD SIGNAL

Check signal between satellite radio tuner harness connector B56 terminal 30 and ground with CONSULT-III or oscilloscope.

30 - Ground : Refer to [AV-30, "Terminal and Reference Value for Satellite Radio Tuner"](#).

OK or NG

- OK >> Replace satellite radio tuner. Refer to [AV-51, "Removal and Installation"](#).
- NG >> Replace audio unit. Refer to [AV-51, "Removal and Installation"](#).

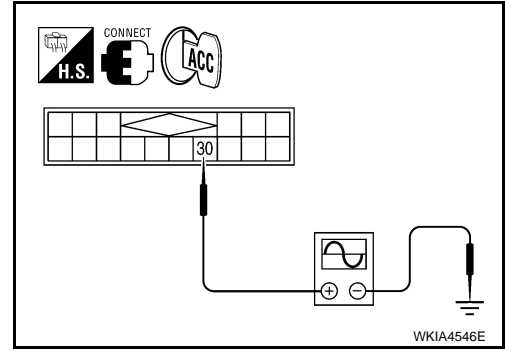

Satellite Radio Tuner Left Channel Audio Signal Circuit Inspection

INFOID:000000004409440

1. CHECK HARNESS

1. Turn ignition switch OFF.
2. Disconnect satellite radio tuner connector B56 (A) and audio unit connector M45 (B).
3. Check continuity between satellite radio tuner and audio unit.

Terminals				Continuity
Satellite radio tuner		Audio unit		
Connector	Terminal	Connector	Terminal	
A: B56	21	B: M45	33	Yes
	22		34	

4. Check continuity between satellite radio tuner and ground.

Terminals				Continuity
Satellite radio tuner		—		
Connector	Terminal			
A: B56	21	Ground		No
	22			

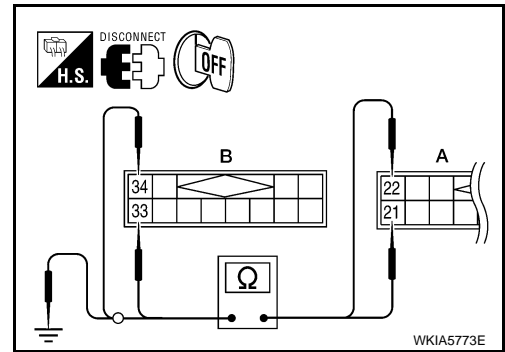

OK or NG

- OK >> GO TO 2.
- NG >> Repair harness or connector.

2. CHECK LEFT CHANNEL AUDIO SIGNAL

1. Connect satellite radio tuner and audio unit.
2. Turn ignition switch ON.
3. Check signal between satellite radio tuner connector B56 terminals 21 and 22 with CONSULT-III or oscilloscope.

21 - 22 : Refer to [AV-30, "Terminal and Reference Value for Satellite Radio Tuner"](#).

OK or NG

- OK >> Replace audio unit. Refer to [AV-51, "Removal and Installation"](#).
- NG >> Replace satellite radio tuner. Refer to [AV-51, "Removal and Installation"](#).

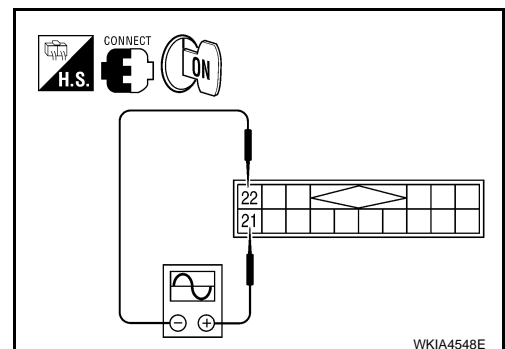

AUDIO

< SERVICE INFORMATION >

Satellite Radio Tuner Right Channel Audio Signal Circuit Inspection

INFOID:000000004409441

1. CHECK HARNESS

1. Turn ignition switch OFF.
2. Disconnect satellite radio tuner connector B56 (A) and audio unit connector M45 (B).
3. Check continuity between satellite radio tuner and audio unit.

Terminals				Continuity
Satellite radio tuner		Audio unit		
Connector	Terminal	Connector	Terminal	
A: B56	23	B: M45	35	Yes
	24		36	

4. Check continuity between satellite radio tuner and ground.

Terminals				Continuity
Satellite radio tuner		—		
Connector	Terminal			
A: B56	23	Ground		No
	24			

OK or NG

- OK >> GO TO 2.
 NG >> Repair harness or connector.

2. CHECK RIGHT CHANNEL AUDIO SIGNAL

1. Connect satellite radio tuner and audio unit.
2. Turn ignition switch ON.
3. Check signal between satellite radio tuner connector B56 terminals 23 and 24 with CONSULT-III or oscilloscope.

23 - 24 : Refer to [AV-30, "Terminal and Reference Value for Satellite Radio Tuner"](#).

OK or NG

- OK >> Replace audio unit. Refer to [AV-51, "Removal and Installation"](#).
 NG >> Replace satellite radio tuner. Refer to [AV-51, "Removal and Installation"](#).

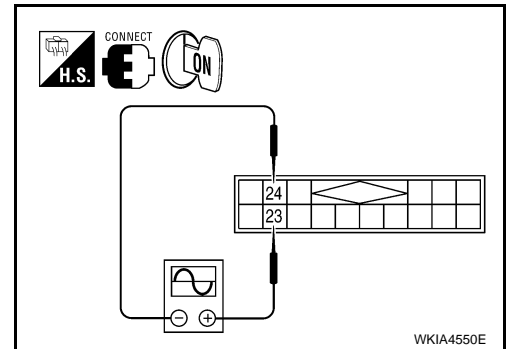
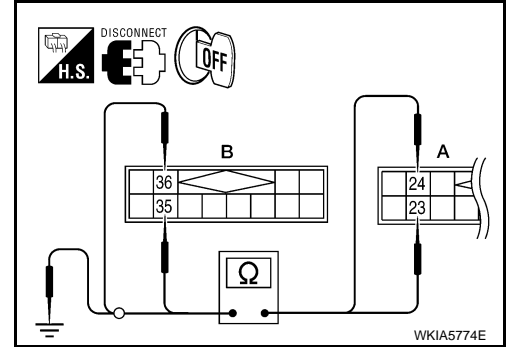

Steering Switch Check (With Bluetooth)

INFOID:000000004409442

1. CHECK HARNESS

1. Turn ignition switch OFF.
2. Disconnect Bluetooth control unit connector B15 and spiral cable connector M30.
3. Check continuity between Bluetooth control unit connector B15 (A) terminals 12, 13, and 14 and spiral cable connector M30 (B) terminals 25, 31, and 33.

AUDIO

< SERVICE INFORMATION >

Terminals				Continuity
A		B		
Connector	Terminal	Connector	Terminal	
B15	12	M30	33	Yes
	13		31	
	14		25	

4. Check continuity between Bluetooth control unit and ground.

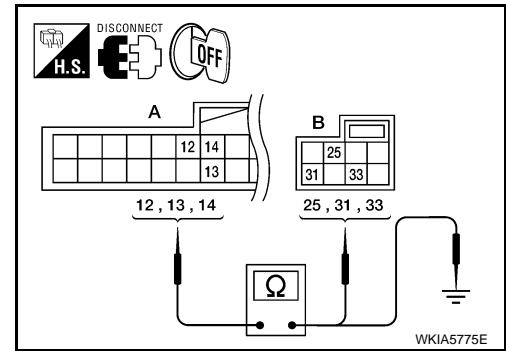

Terminals			Continuity
(+)		(-)	
Connector	Terminal		
B15	12	Ground	No
	13		
	14		

OK or NG

- OK >> GO TO 2.
- NG >> Repair harness.

2. CHECK HARNESS

1. Disconnect audio unit connector M43.
2. Check continuity between audio unit connector M43 (A) terminals 6, 15, and 16 and Bluetooth control unit connector B15 (B) terminals 17, 19, and 18.

Terminals				Continuity
(A)		(B)		
Connector	Terminal	Connector	Terminal	
M43	6	B15	17	Yes
	15		19	
	16		18	

OK or NG

- OK >> GO TO 3.
- NG >> Repair harness.

3. SPIRAL CABLE CHECK

1. Disconnect spiral cable connector M78.
2. Check continuity between spiral cable terminals.

- 15 - 33 : Continuity should exist.**
- 17 - 31 : Continuity should exist.**
- 19 - 25 : Continuity should exist.**

OK or NG

- OK >> GO TO 4.
- NG >> Replace spiral cable. Refer to [SRS-33, "Removal and Installation"](#).

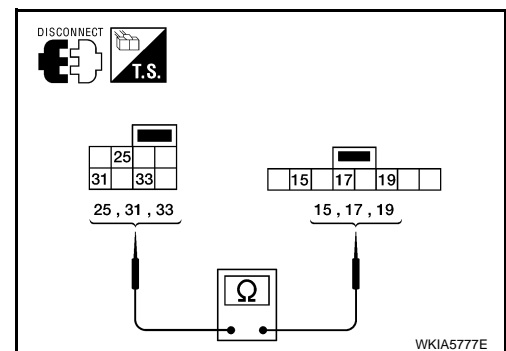
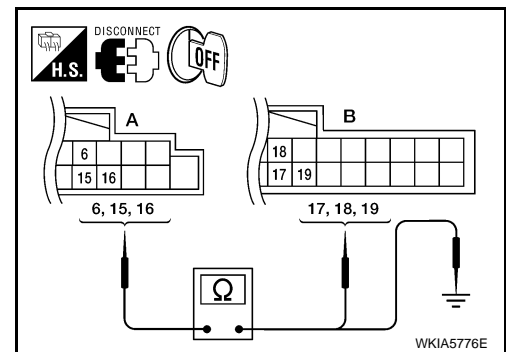

4. CHECK STEERING SWITCH RESISTANCE

Check resistance between spiral cable connector M78 terminals.

AUDIO

< SERVICE INFORMATION >

Terminal	Signal name	Condition	Resistance (Ω) (Approx.)	
17	19	Seek (down)	Depress Seek down switch.	165
		Phone/Send	Depress Phone/Send switch.	0
		Volume (down)	Depress volume down switch.	487
15	19	Seek (up)	Depress Seek up switch.	165
		Phone/End	Depress Phone/End switch.	0
		Volume (up)	Depress volume up switch.	487

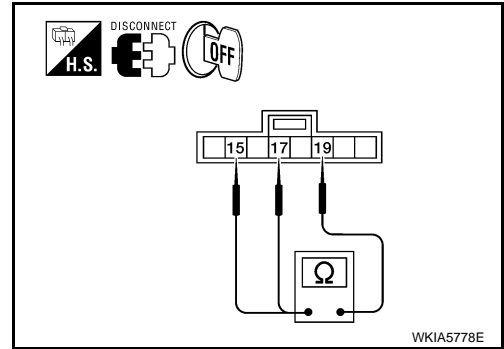

WKIA5778E

OK or NG

OK >> Inspection End.

NG >> Replace steering switch. Refer to [AV-51. "Removal and Installation"](#).

Steering Switch Check (Without Bluetooth)

INFOID:000000004409443

1. AUDIO UNIT SELF-DIAGNOSIS MODE CHECK

1. Start audio unit self-diagnosis mode. Refer to [AV-83. "Self-Diagnosis Mode"](#).
2. Operate steering switch.

Does steering switch operate normally?

YES >> Inspection End.

NO >> GO TO 2.

2. CHECK HARNESS

1. Turn ignition switch OFF.
2. Disconnect audio unit connector M43 and spiral cable connector M30.
3. Check continuity between audio unit connector terminal and spiral cable connector terminal.

Terminals				Continuity
A		B		
Connector	Terminal	Connector	Terminal	
M43	6	M30	33	Yes
	15		25	
	16		31	

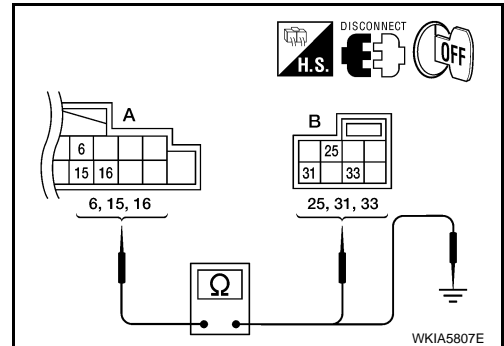

WKIA5807E

4. Check continuity between audio unit and ground.

Terminals			Continuity
A		(-)	
Connector	Terminal		
M43	6	Ground	No
	15		
	16		

OK or NG

OK >> GO TO 3.

NG >> Repair harness.

3. SPIRAL CABLE CHECK

1. Disconnect spiral cable connector M78.

AUDIO

< SERVICE INFORMATION >

2. Check continuity between spiral cable terminals.

- 15 - 33 : Continuity should exist.**
- 17 - 31 : Continuity should exist.**
- 19 - 25 : Continuity should exist.**

OK or NG

- OK >> GO TO 4.
- NG >> Replace spiral cable. Refer to [SRS-33. "Removal and Installation"](#).

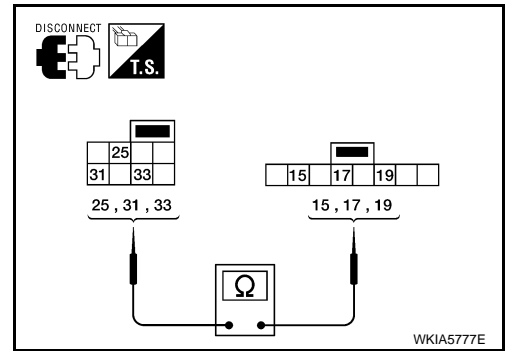

4. CHECK STEERING SWITCH RESISTANCE

Check resistance between spiral cable connector M102 terminals.

Terminal	Signal name	Condition	Resistance (Ω) (Approx.)	
17	19	Seek (down)	Depress (station) down switch.	165
		Power	Depress power switch.	0
		Volume (down)	Depress volume down switch.	487
15	19	Seek (up)	Depress (station) up switch.	165
		Mode	Depress mode switch.	0
		Volume (up)	Depress volume up switch.	487

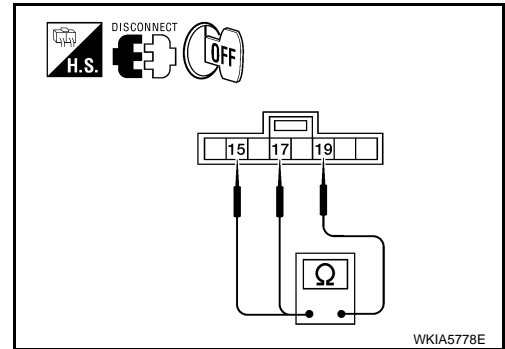

OK or NG

- OK >> Inspection End.
- NG >> Replace steering switch. Refer to [AV-51. "Removal and Installation"](#).

Sound Is Not Heard from Front Door Speaker or Front Tweeter (Base and Mid System)

INFOID:000000004409444

1. HARNESS CHECK

- Disconnect audio unit connector and front door speaker and front tweeter (mid system) connector (LH or RH).
- Check continuity between audio unit harness connector terminal and front door speaker and front tweeter (mid system) harness connector terminal.

Terminals				Continuity
Audio unit		Speaker or tweeter		
Connector	Terminal	Connector	Terminal	
A: M43	2	B: M46*	+	Yes
	3		-	
	11	B: M47*	+	
	12		-	
	2	B: D10	+	
	3		-	
	11	B: D108	+	
	12		-	

*: With mid system

- Check continuity between audio unit harness connector terminal and ground.

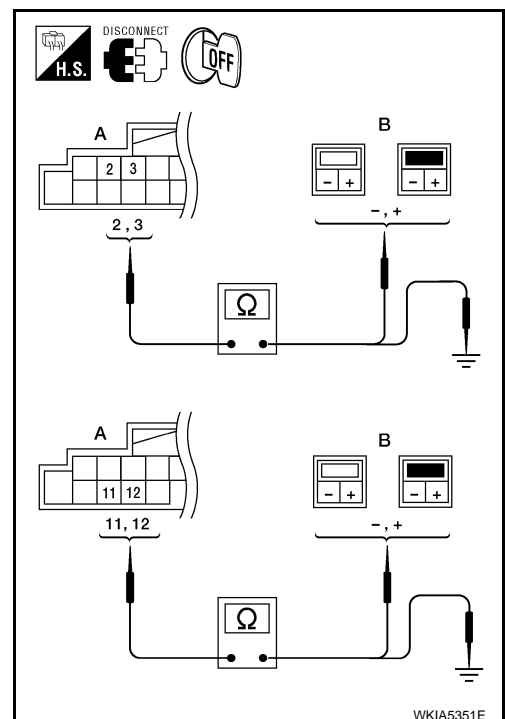

AUDIO

< SERVICE INFORMATION >

Terminals		—	Continuity
Audio unit			
Connector	Terminal		
A: M43	2	Ground	No
	3		
	11		
	12		

OK or NG

OK >> GO TO 2.

NG >> • Check connector housings for disconnected or loose terminals.
• Repair harness or connector.

2. FRONT SPEAKER SIGNAL CHECK

1. Connect audio unit connector, front door speaker connector and front tweeter (mid system) connector.
2. Turn ignition switch to ACC.
3. Push "POWER" switch.
4. Check the signal between audio unit connector terminals with CONSULT-III or oscilloscope.

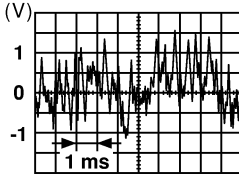
Terminals				Condi- tion	Reference signal
(+) (+)		(-) (-)			
Con- nector	Termi- nal	Con- nector	Termi- nal		
M43	2	M43	3	Receive audio signal	
	11		12		

SKIA0177E

OK or NG

OK >> Replace front speaker. Refer to [AV-51. "Removal and Installation"](#).

NG >> Replace audio unit. Refer to [AV-51. "Removal and Installation"](#).

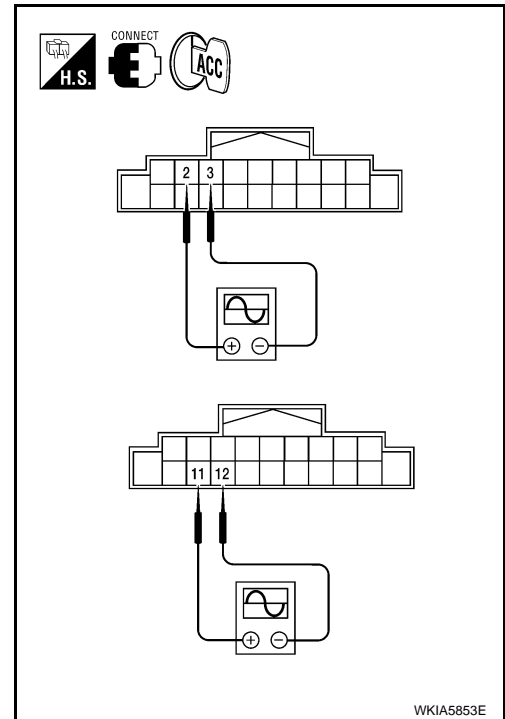

WKIA5853E

Sound Is Not Heard from Rear Speaker (Base and Mid System)

INFOID:000000004409445

1. HARNESS CHECK

1. Disconnect audio unit connector and rear speaker connector.

AUDIO

< SERVICE INFORMATION >

- Check continuity between audio unit harness connector terminal and rear speaker harness connector terminal.

Terminals				Continuity
Audio unit		Speaker		
Connector	Terminal	Connector	Terminal	
A: M43	4	B: B27	+	Yes
	5		-	
	13	B: B39	+	
	14		-	

- Check continuity between audio unit harness connector terminal and ground.

Terminals				Continuity
Audio unit		—		
Connector	Terminal			
A: M43	4	Ground		No
	5			
	13			
	14			

OK or NG

- OK >> GO TO 2.
 NG >> • Check connector housings for disconnected or loose terminals.
 • Repair harness or connector.

2. REAR SPEAKER SIGNAL CHECK

- Connect audio unit connector and rear speaker connector.
- Turn ignition switch to ACC.
- Push "POWER" switch.
- Check the signal between audio unit harness connector terminals with CONSULT-III or oscilloscope.

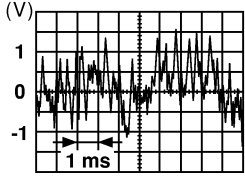
Terminals				Condition	Reference signal
(+)		(-)			
Connector	Terminal	Connector	Terminal		
M43	4	M43	5	Re-ceive audio signal	
	13		14		

OK or NG

- OK >> Replace speaker. Refer to [AV-51. "Removal and Installation"](#).
 NG >> Replace audio unit. Refer to [AV-51. "Removal and Installation"](#).

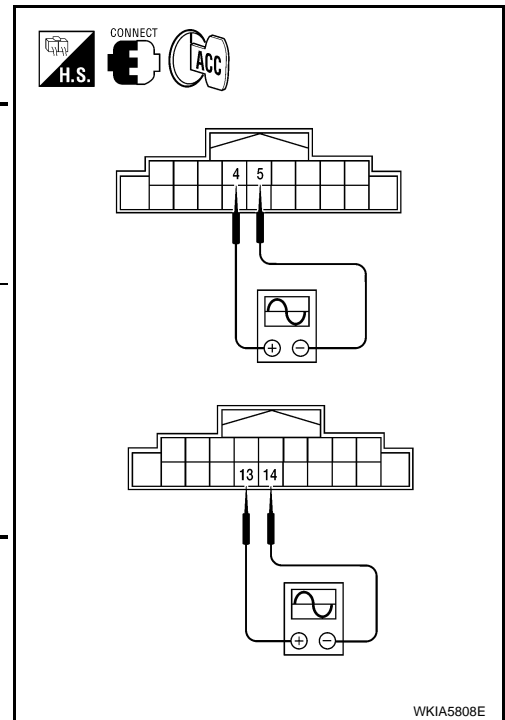
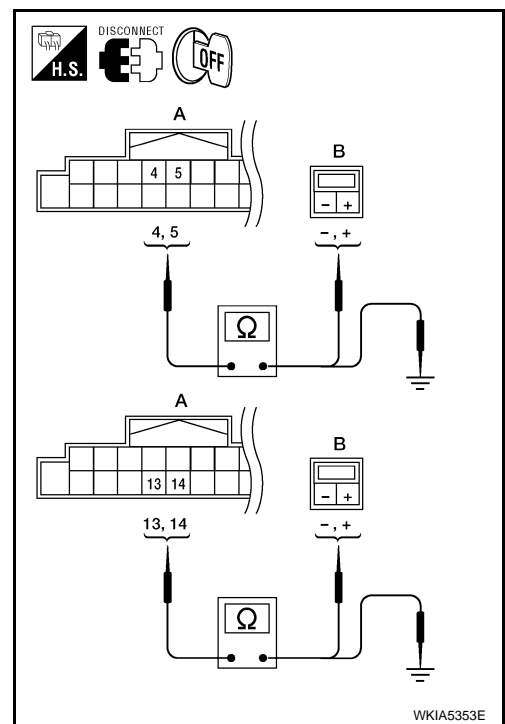

AUDIO

< SERVICE INFORMATION >

Sound Is Not Heard from Front Door Speaker or Front Tweeter (Premium System)

INFOID:000000004409446

1. HARNESS CHECK

1. Turn ignition switch OFF.
2. Disconnect audio amplifier connector B43 and suspect speaker connector.
3. Check continuity between audio amplifier harness connector terminal and suspect speaker harness connector terminal.

Terminals				Continuity
Audio amplifier		Speaker or tweeter		
Connector	Terminal	Connector	Terminal	
B43	15	D10	+	Yes
	31		-	
	16	D108	+	
	32		-	
	14	M46	-	
	30		+	
	13	M47	-	
	29		+	

4. Check continuity between audio amplifier harness connector terminal and ground.

Terminals			Continuity
Audio amplifier		—	
Connector	Terminal		
B43	13	Ground	No
	14		
	15		
	16		
	29		
	30		
	31		
	32		

OK or NG

OK >> GO TO 2.

NG >> • Check connector housings for disconnected or loose terminals.
• Repair harness or connector.

2. FRONT SPEAKER SIGNAL CHECK

1. Connect audio amplifier connector B43 and suspect speaker connector.
2. Turn ignition switch to ACC.
3. Push "POWER" switch.

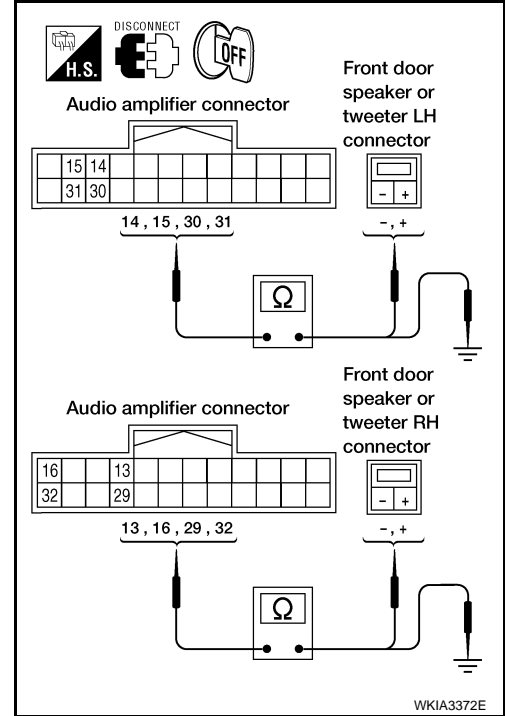

AUDIO

< SERVICE INFORMATION >

- Check the signal between audio amplifier harness connector terminals with CONSULT-III or oscilloscope.

Terminals				Condi- tion	Reference signal
(+) (+)		(-) (-)			
Con- nector	Termi- nal	Con- nector	Termi- nal		
B43	13	B43	29	Re- ceive audio signal	
	14		30		
	15		31		
	16		32		

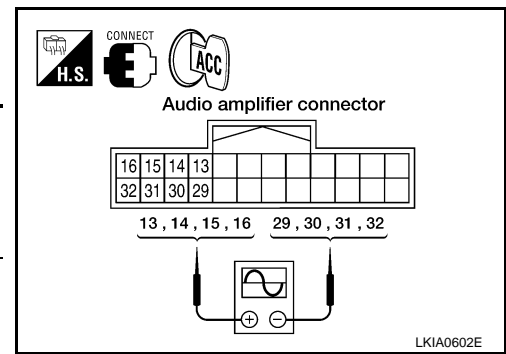

OK or NG

- OK >> Replace suspect speaker. Refer to [AV-51, "Removal and Installation"](#) or [AV-51, "Removal and Installation"](#).
- NG >> GO TO 3.

3. HARNESS CHECK

- Turn ignition switch OFF.
- Disconnect audio unit connector M43 and audio amplifier connector B43.
- Check continuity between audio unit harness connector terminals and audio amplifier harness connector terminals.

Terminals				Continuity
Audio unit		Audio amplifier		
Connector	Terminal	Connector	Terminal	
A: M43	3	B: B43	6	Yes
	2		22	
	12		5	
	11		21	

- Check continuity between audio unit harness connector terminals and ground.

Terminals				Continuity
Audio unit		—		
Connector	Terminal			
A: M43	3	Ground		No
	2			
	12			
	11			

OK or NG

- OK >> GO TO 4.
- NG >> • Check connector housings for disconnected or loose terminals.
• Repair harness or connector.

4. FRONT SPEAKER SIGNAL CHECK

- Connect audio unit connector and audio amplifier connector.
- Turn ignition switch to ACC.
- Push "POWER" switch.

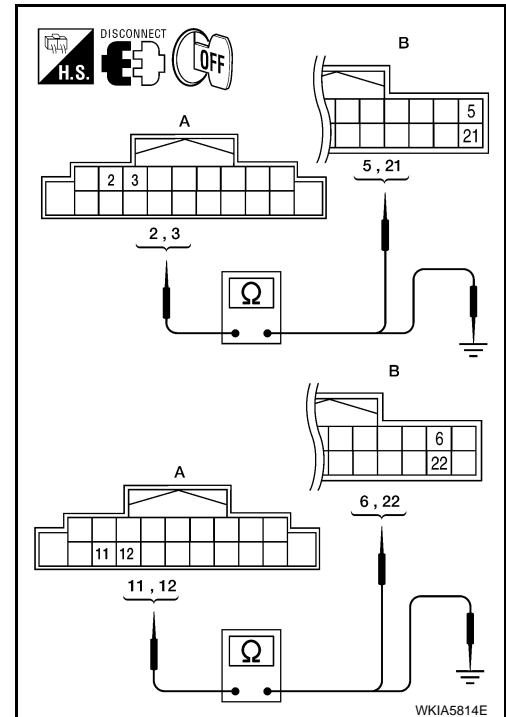

AUDIO

< SERVICE INFORMATION >

- Check the signal between audio unit harness connector terminals with CONSULT-III or oscilloscope.

Terminals				Condi- tion	Reference signal
(+)		(-)			
Con- nector	Termi- nal	Con- nector	Termi- nal		
M43	2	M43	3	Receive audio signal	
	11		12		

OK or NG

- OK >> Replace audio amplifier. Refer to [AV-51, "Removal and Installation"](#).
- NG >> Replace audio unit. Refer to [AV-51, "Removal and Installation"](#).

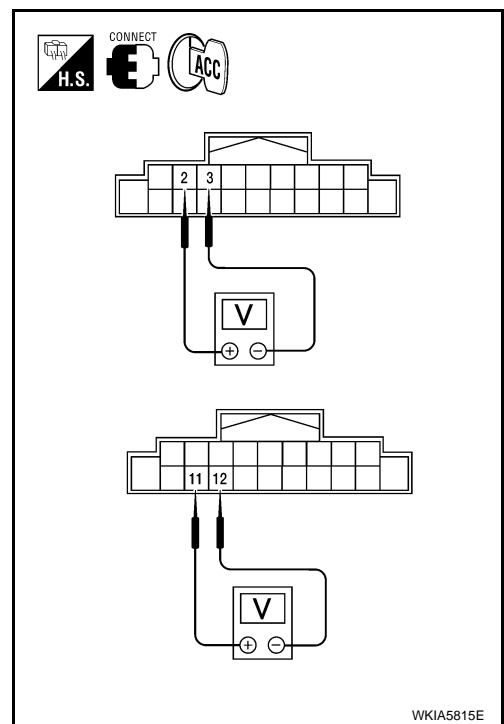

Sound Is Not Heard from Rear Speaker Assembly (Premium System)

INFOID:000000004409447

1. HARNESS CHECK

- Turn ignition switch OFF.
- Disconnect audio amplifier connectors B43, B44 and suspect speaker connector.
- Check continuity between audio amplifier harness connector terminal and suspect speaker harness connector terminal.

Terminals				Continuity
Audio amplifier		Speaker		
Connector	Terminal	Connector	Terminal	
A: B43	11	C: B40	4	Yes
	27		3	
	12	C: B38	4	
	28		3	
B: B44	2	C: B40	2	
	18		1	
	3	C: B38	2	
	19		1	

- Check continuity between audio amplifier harness connector terminals and ground.

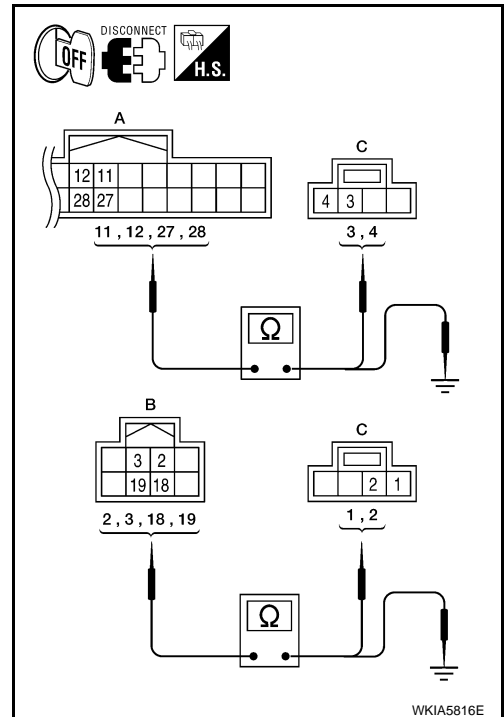

AUDIO

< SERVICE INFORMATION >

Terminals		—	Continuity
Audio amplifier			
Connector	Terminal		
A: B43	11	Ground	No
	27		
	12		
	28		
B: B44	2		
	18		
	3		
	19		

OK or NG

OK >> GO TO 2.

NG >> • Check connector housings for disconnected or loose terminals.
• Repair harness or connector.

2. REAR SPEAKER SIGNAL CHECK

1. Connect audio amplifier connectors B43, B44 and suspect speaker connector.
2. Turn ignition switch to ACC.
3. Push "POWER" switch.
4. Check the signal between audio amplifier harness connector terminals with CONSULT-III or oscilloscope.

Terminals				Condi- tion	Reference signal
(+)		(-)			
Con- nec- tor	Terminal	Con- nec- tor	Terminal		
A: B43	11	A: B43	27	Re- ceive audio signal	
	12		28		
B: B44	2	B: B44	18		
	3		19		

OK or NG

OK >> Replace suspect speaker. Refer to [AV-51, "Removal and Installation"](#).

NG >> GO TO 3.

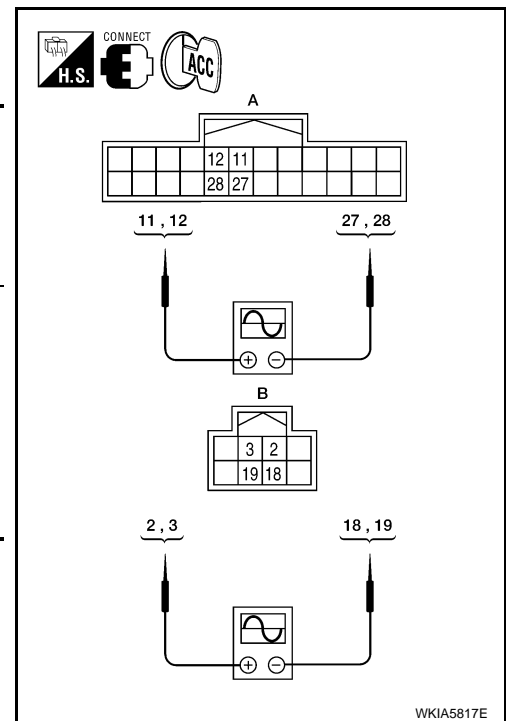

3. HARNESS CHECK

1. Turn ignition switch OFF.
2. Disconnect audio unit connector M43 and audio amplifier connector B43.

AUDIO

< SERVICE INFORMATION >

- Check continuity between audio unit harness connector terminals and audio amplifier harness connector terminals.

Terminals				Continuity
Audio unit		Audio amplifier		
Connector	Terminal	Connector	Terminal	
A: M43	5	B: B43	8	Yes
	4		24	
	14		7	
	13		23	

- Check continuity between audio unit harness connector terminal and ground.

Terminals			Continuity
Audio unit		—	
Connector	Terminal		
A: M43	5	Ground	No
	4		
	14		
	13		

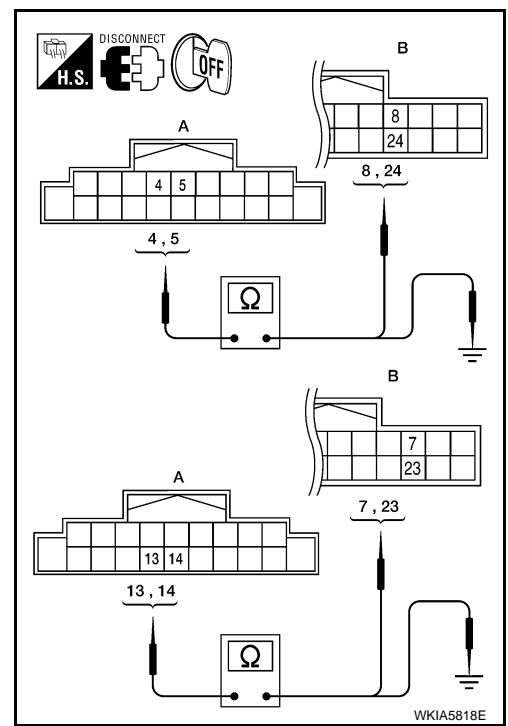

OK or NG

- OK >> GO TO 4.
 NG >> • Check connector housings for disconnected or loose terminals.
 • Repair harness or connector.

4. REAR SPEAKER SIGNAL CHECK

- Connect audio unit connector M43 and audio amplifier connector B43.
- Turn ignition switch to ACC.
- Push "POWER" switch.
- Check the signal between audio unit harness connector terminals with CONSULT-III or oscilloscope.

Terminals				Condition	Reference signal
(+)		(-)			
Con-connector	Terminal	Con-connector	Terminal		
M43	4	M43	5	Receive audio signal	
	13		14		

SKIA0177E

OK or NG

- OK >> Replace audio amplifier. Refer to [AV-51. "Removal and Installation"](#).
 NG >> Replace audio unit. Refer to [AV-51. "Removal and Installation"](#).

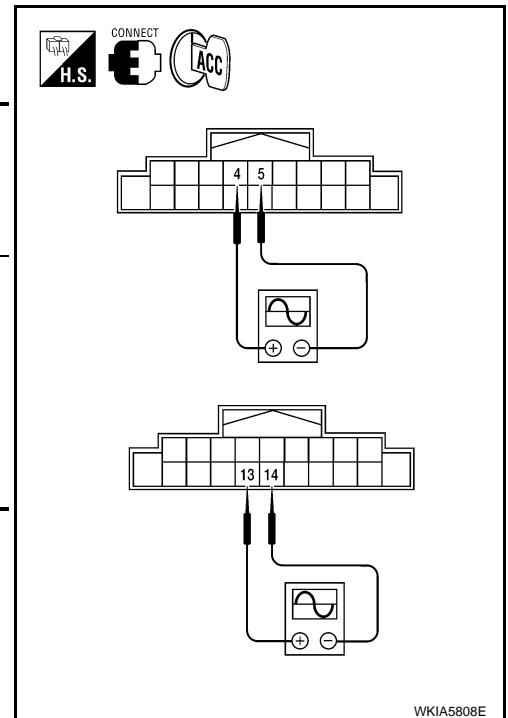

AUDIO

< SERVICE INFORMATION >

Removal and Installation

INFOID:000000004409448

AUDIO UNIT

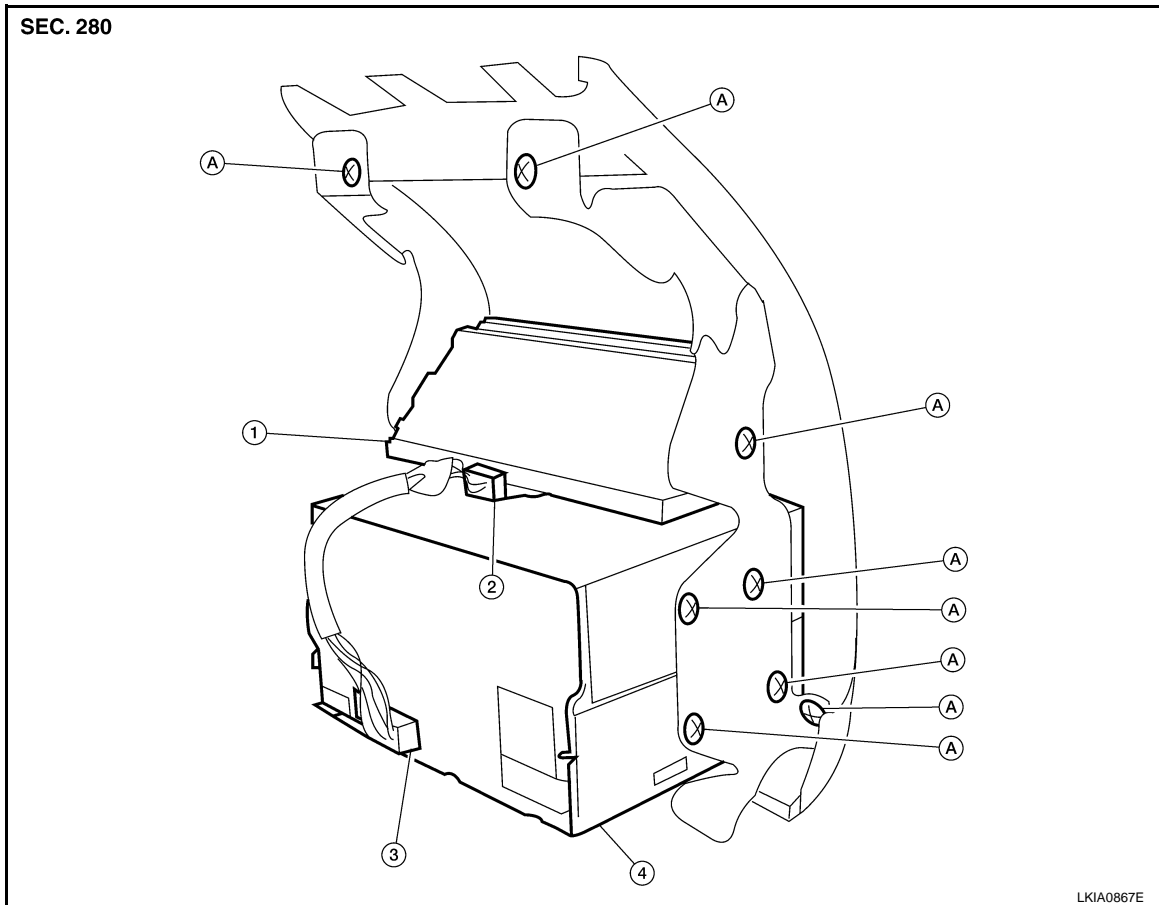

- 1. Display unit
- 2. Display unit connector
- 3. Audio unit connector
- 4. Audio unit
- A. Cluster lid C bracket screws

Removal

1. Remove the cluster lid C. Refer to [IP-11](#).
2. Remove the display unit to audio unit harness.
3. Remove the cluster lid C bracket screws.
4. Remove the audio unit and display unit (if equipped).

Installation

Installation is in the reverse order of removal.

FRONT TWEETER

Removal

1. Remove the front pillar garnish. Refer to [EI-33](#).
2. Remove the front tweeter grille.

A
B
C
D
E
F
G
H
I
J
AV
L
M
N
O
P

AUDIO

< SERVICE INFORMATION >

3. Remove the front tweeter screws (A), disconnect the front tweeter connector and remove the front tweeter (1).

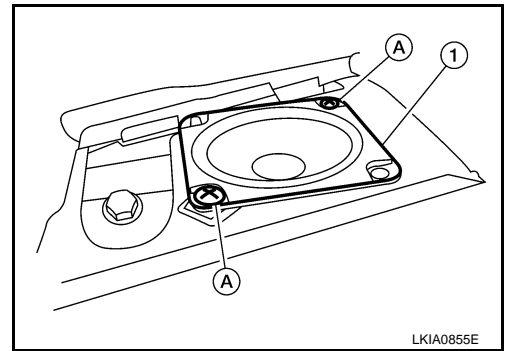

Installation

Installation is in the reverse order of removal.

FRONT DOOR SPEAKER

Removal

1. Remove the front door finisher. Refer to [EI-30](#).
2. Remove the front door speaker screws (A), disconnect the front door speaker connector and remove the front door speaker (1).

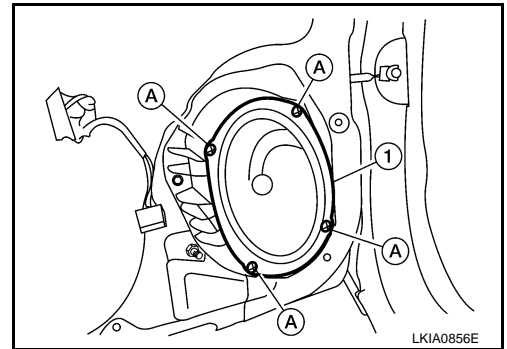

Installation

Installation is in the reverse order of removal.

REAR SPEAKER, REAR SPEAKER ASSEMBLY

Removal

1. Remove the rear parcel shelf finisher. Refer to [EI-37, "Removal and Installation"](#).
2. Remove the rear speaker screws (A), disconnect the rear speaker connector and remove the rear speaker (1).

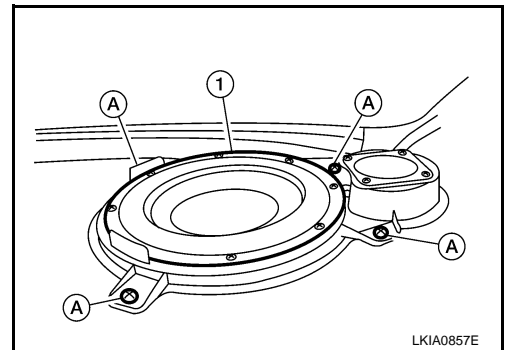

Installation

Installation is in the reverse order of removal.

AUDIO AMPLIFIER

AUDIO

< SERVICE INFORMATION >

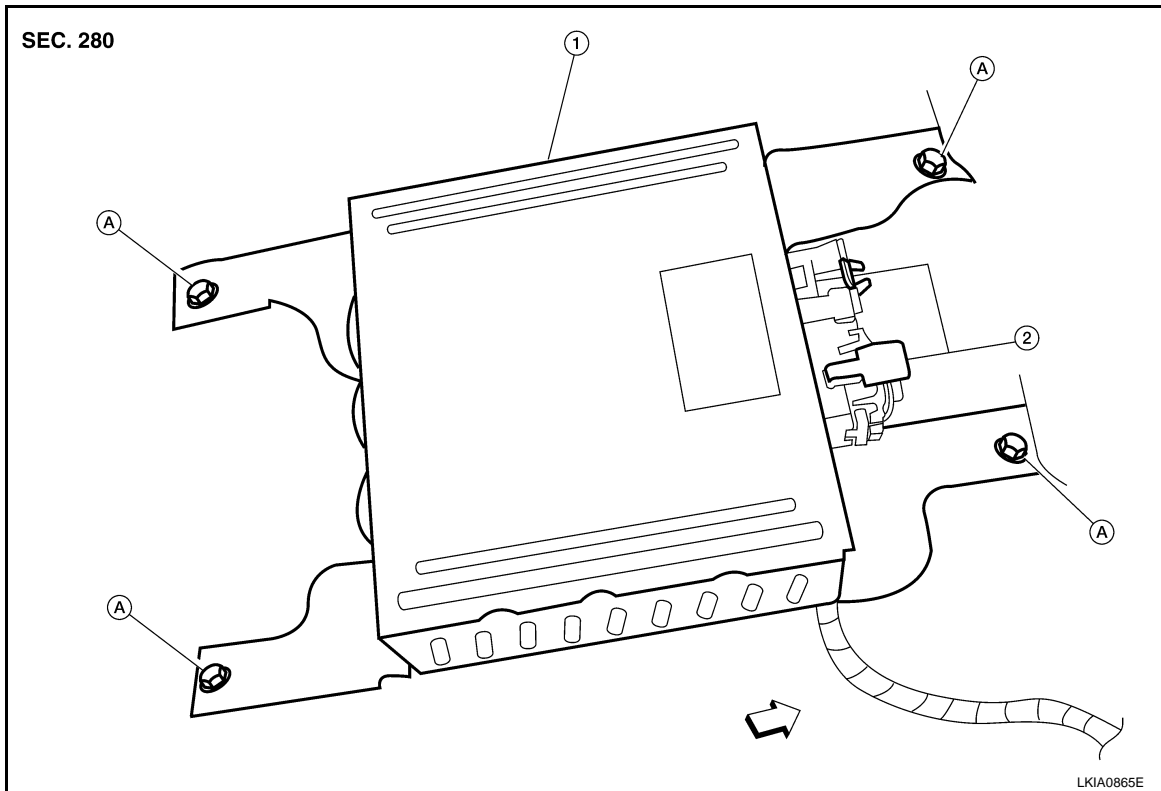

1. Audio amplifier

⇒ Front

2. Audio amplifier connectors

A. Bolts

Removal

1. Slide the RH front seat toward the front to remove the audio amplifier rear bolts.
2. Slide the RH front seat toward the rear to remove the audio amplifier front bolts.
3. Disconnect the audio amplifier connectors and remove the audio amplifier.

Installation

Installation is in the reverse order of removal.

SATELLITE RADIO TUNER

A
B
C
D
E
F
G
H
I
J
L
M
N
O
P

AV

AUDIO

< SERVICE INFORMATION >

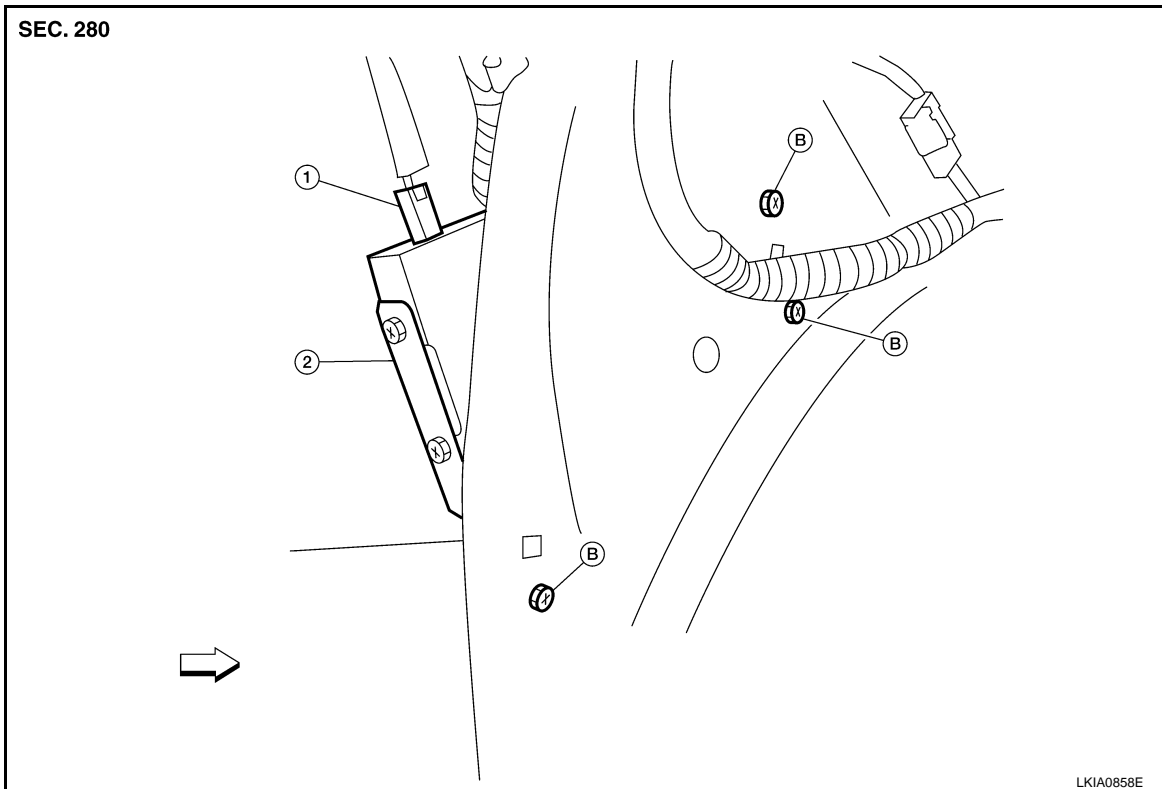

1. Satellite radio tuner connector

2. Satellite radio tuner

B. Bolts

⇒ Front

Removal

1. Remove the luggage side finisher (LH). Refer to [EI-43, "Removal and Installation"](#).
2. Remove the satellite radio tuner bolts.
3. Disconnect the satellite radio tuner connector and remove the satellite radio tuner.
4. If necessary, remove the satellite radio tuner bracket bolts (A) and remove the satellite radio tuner brackets (1).

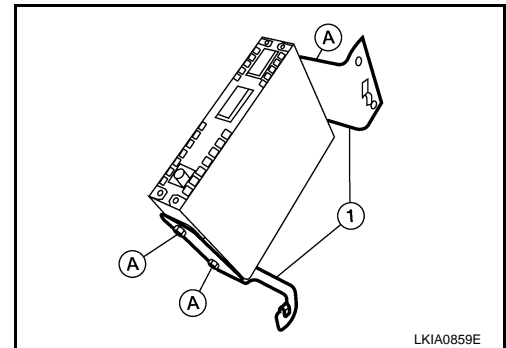

Installation

Installation is in the reverse order of removal.

STEERING WHEEL AUDIO CONTROL SWITCHES

Removal

1. Remove the driver air bag module. Refer to [SRS-31](#).

AUDIO

< SERVICE INFORMATION >

2. Remove the steering wheel audio control switch screws (A) and remove the steering wheel audio control switches (1).

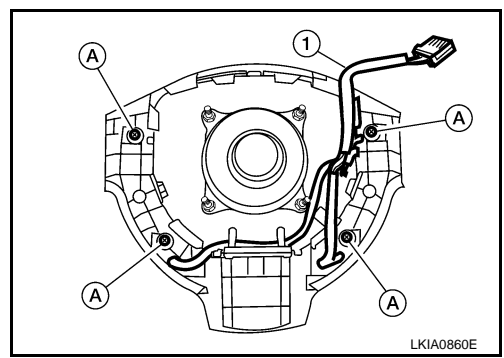

Installation

Installation is in the reverse order of removal.

A
B
C
D
E
F
G
H
I
J
AV
L
M
N
O
P

AUDIO ANTENNA

< SERVICE INFORMATION >

AUDIO ANTENNA

Location of Antenna

INFOID:000000004409449

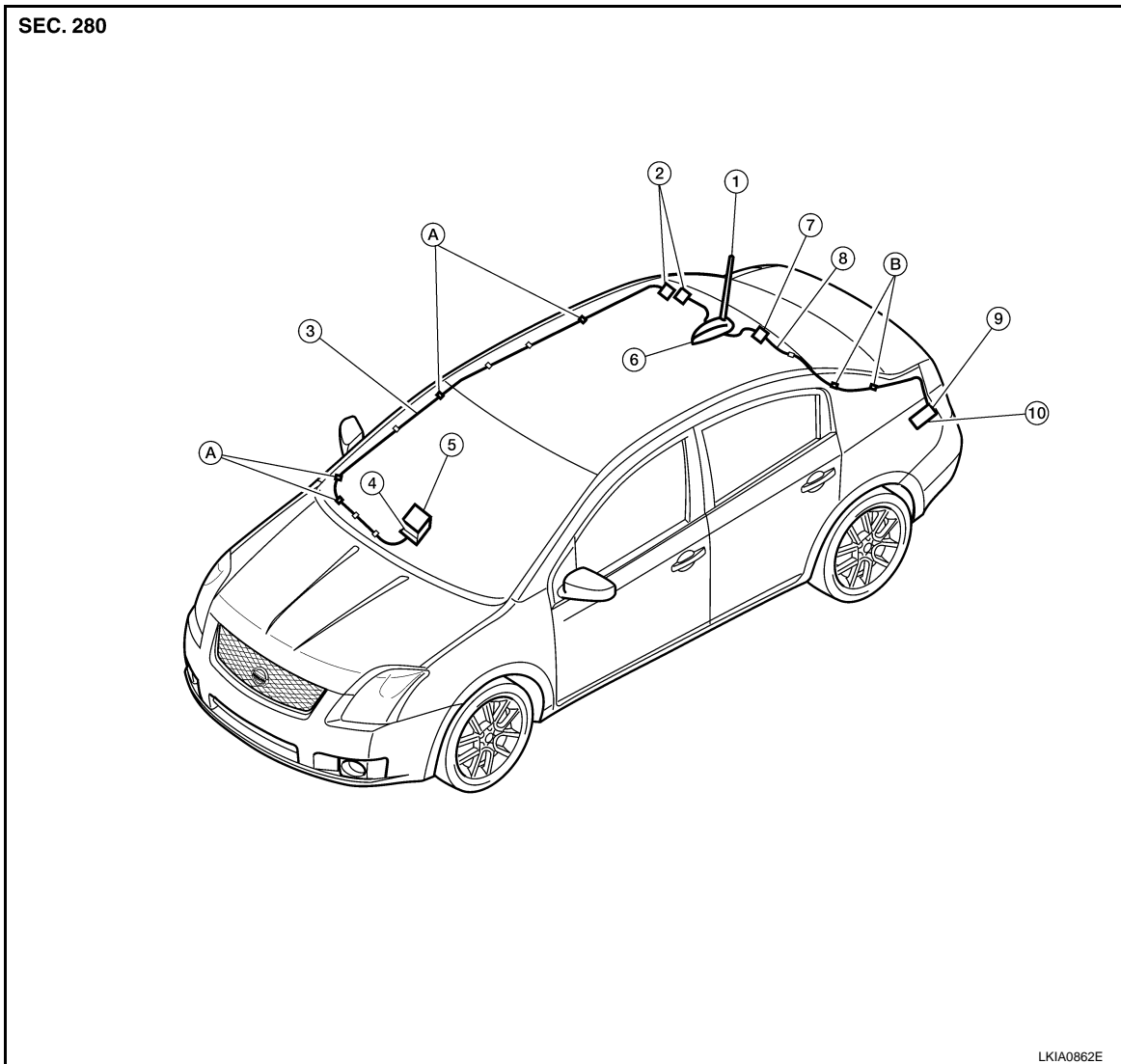

- | | | |
|---|---|---|
| 1. Roof antenna | 2. Roof antenna base connectors | 3. Antenna feeder |
| 4. Antenna feeder connector | 5. Audio unit | 6. Roof antenna base |
| 7. Satellite radio tuner antenna feeder connector | 8. Satellite radio tuner antenna feeder | 9. Satellite radio tuner antenna feeder connector |
| 10. Satellite radio tuner | A. Antenna feeder clips | B. Satellite radio tuner antenna feeder clips |

Removal and Installation of Roof Antenna

INFOID:000000004409450

REMOVAL

1. Remove rear assist grip (LH). Refer to [EI-40](#).
2. Remove three headliner rear clips. Pull down the rear part of the headliner to reposition out of the way.
CAUTION:
Use care when repositioning headliner to avoid causing damage.

AUDIO ANTENNA

< SERVICE INFORMATION >

3. Disconnect the roof antenna harness connectors (B).
4. Remove the roof antenna nut (A) and remove the roof antenna (1).

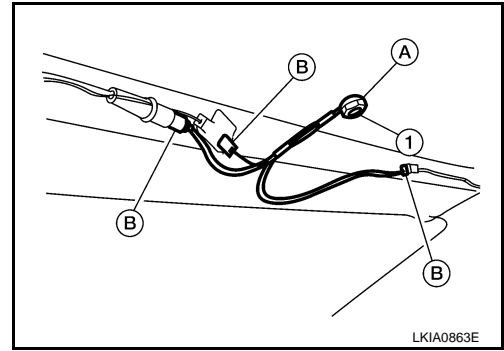

INSTALLATION

Installation is in the reverse order of removal.

A
B
C
D
E
F
G
H
I
J
L
M
N
O
P

AV

TELEPHONE

< SERVICE INFORMATION >

TELEPHONE

Component Parts and Harness Connector Location

INFOID:000000004409451

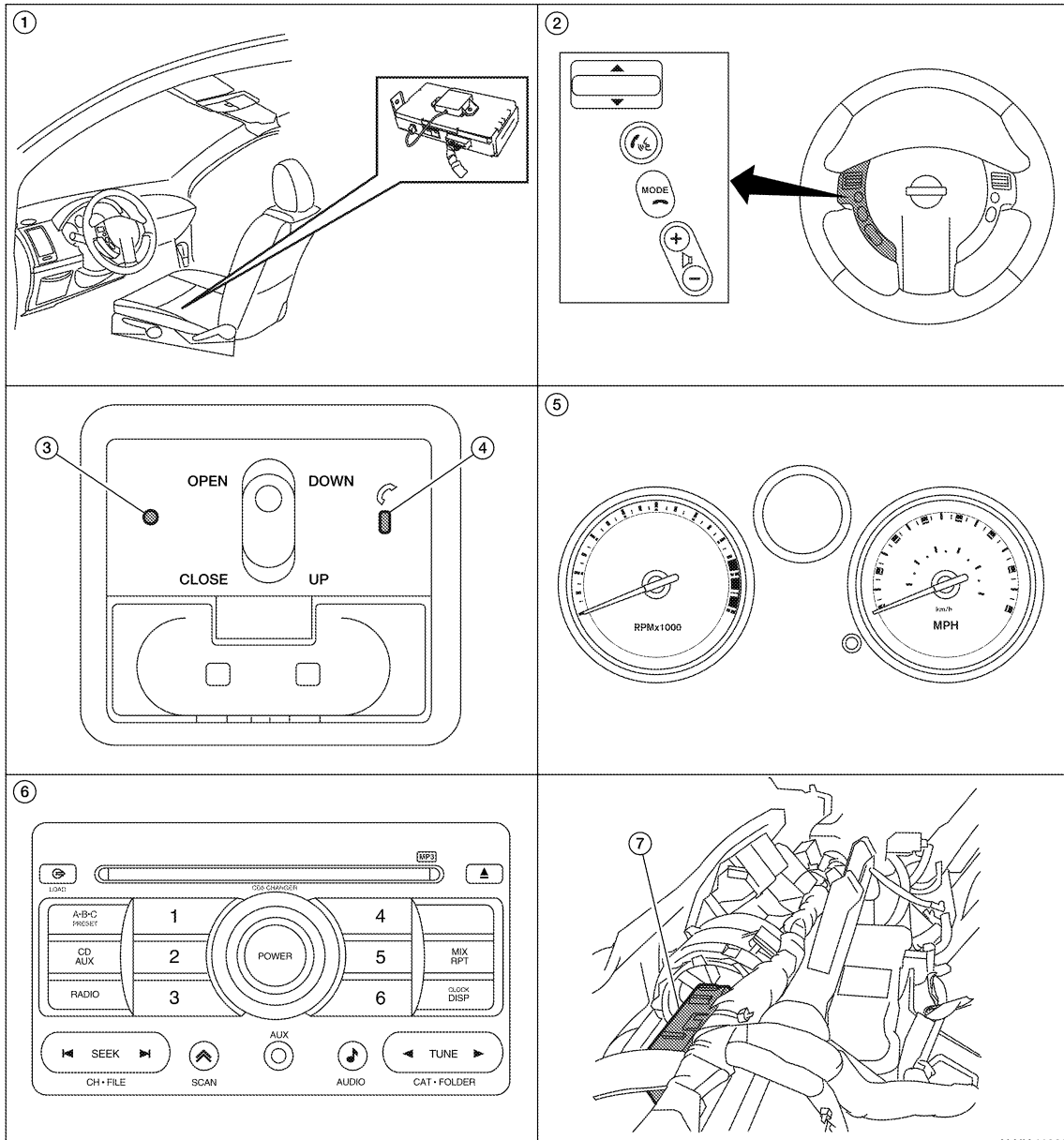

ALNIA1196GB

- | | | |
|--|--|------------------------|
| 1. Bluetooth control unit B15, B62 | 2. Steering wheel audio control switches | 3. Microphone R4 |
| 4. Bluetooth ON indicator R2 | 5. Combination meter M24 | 6. Audio unit M43, M53 |
| 7. BCM M18, M20 (view with instrument panel removed) | | |

System Description

INFOID:000000004409452

BLUETOOTH® HANDS-FREE PHONE SYSTEM

Refer to the Owner's Manual for Bluetooth telephone system operating instructions.

NOTE:

Cellular telephones must have their wireless connection set up (paired) before using the Bluetooth telephone system.

TELEPHONE

< SERVICE INFORMATION >

Bluetooth telephone system allows users who have a Bluetooth cellular telephone to make a wireless connection between their cellular telephone and the Bluetooth control unit. Hands-free cellular telephone calls can be sent and received. Personal memos can be created using the Nissan Voice Recognition system. Some Bluetooth cellular telephones may not be recognized by the Bluetooth control unit. When a cellular telephone or the Bluetooth control unit is replaced, the telephone must be paired with the Bluetooth control unit. Different cellular telephones may have different pairing procedures. Refer to the cellular telephone operating manual.

Bluetooth Telephone System Diagram

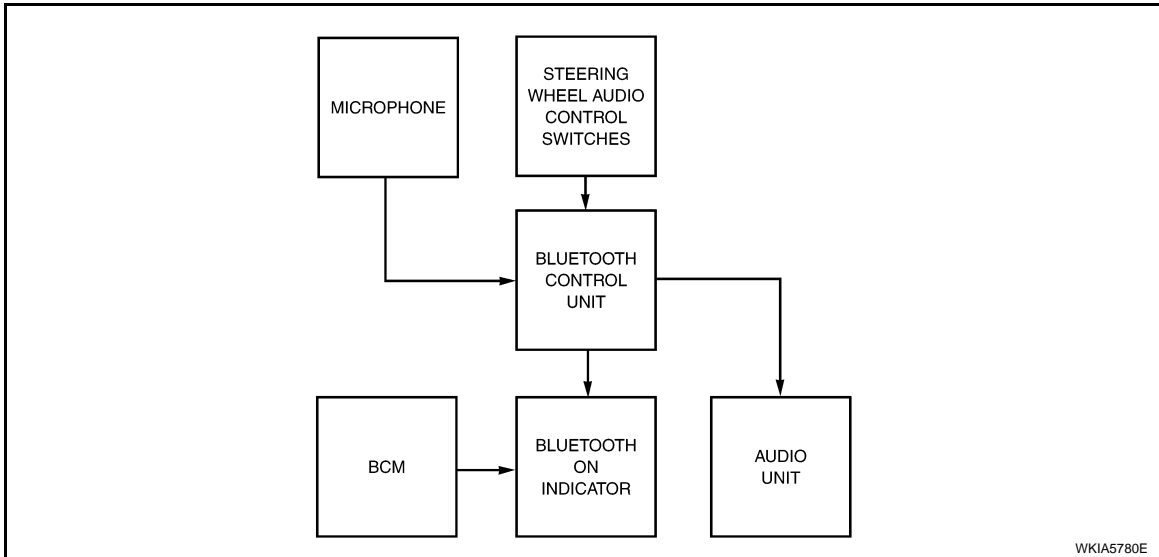

Bluetooth Control Unit

When the ignition switch is turned to ACC or ON, the Bluetooth control unit will power up. During power up, the Bluetooth control unit is initialized and performs various self checks. Initialization may take up to 10 seconds. During this time the Bluetooth ON indicator will flash until initialization is complete. If a phone is present in the vehicle and paired with the Bluetooth control unit, Nissan Voice Recognition will then become active and the Bluetooth ON indicator will remain on. Bluetooth telephone functions can be turned off using the Nissan Voice Recognition system.

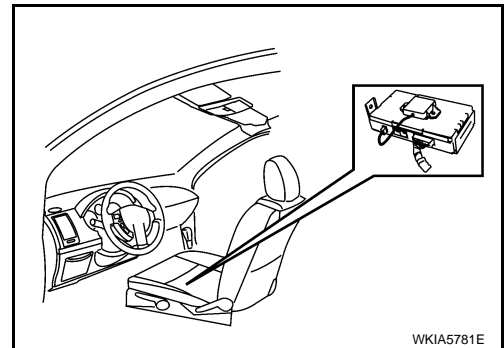

BCM

The BCM supplies power for the Bluetooth ON indicator (view with instrument panel removed).

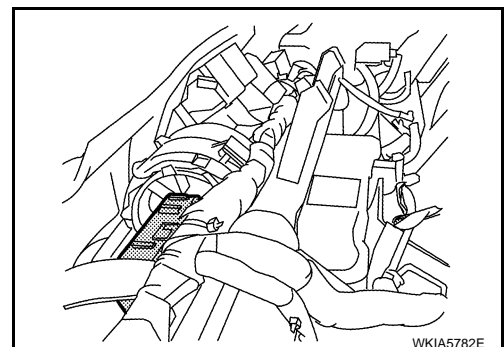

Steering Wheel Audio Control Switches

A
B
C
D
E
F
G
H
I
J
AV
L
M
N
O
P

TELEPHONE

< SERVICE INFORMATION >

When buttons on the steering wheel audio control switch are pushed, the resistance in steering wheel audio control switch circuit changes depending on which button is pushed. The Bluetooth control module uses this signal to perform various functions while navigating through the voice recognition system.

The following functions can be performed using the steering wheel audio control switch:

- Initiate Self Diagnosis of the Bluetooth telephone system
- Start a voice recognition session
- Answer and end telephone calls
- Adjust the volume of calls
- Record memos

Volume Switch

Call volume can be adjusted using the audio unit volume switch.

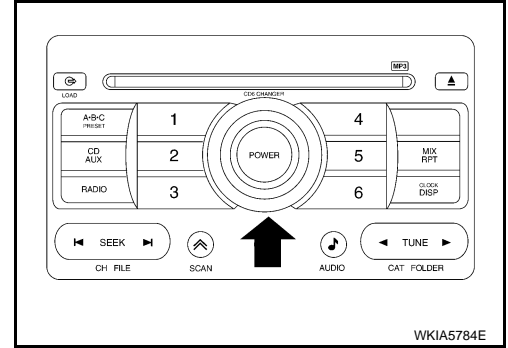
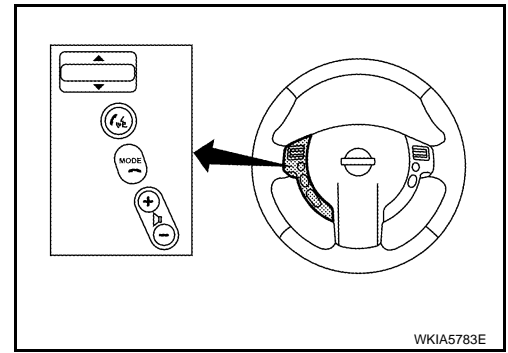

Bluetooth Microphone

The Bluetooth microphone is located in the roof console assembly. The Bluetooth microphone sends a signal to the Bluetooth control unit. The Bluetooth microphone can be actively tested during self-diagnosis.

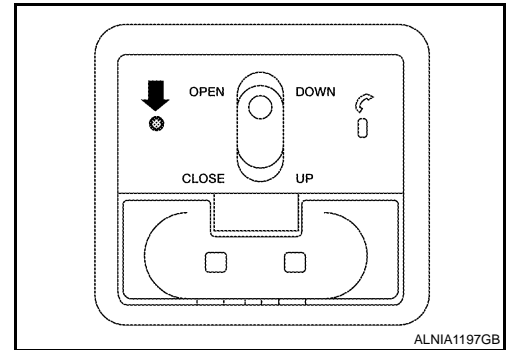

Bluetooth ON Indicator

The Bluetooth ON indicator is located in the roof console assembly. The indicator will flash during power up while the Bluetooth control unit is initializing. This process may take up to 10 seconds. If a phone is present in the vehicle and paired with the Bluetooth control unit, the indicator will remain on to indicate that the system is ready for voice commands. The indicator flashes during self-diagnosis.

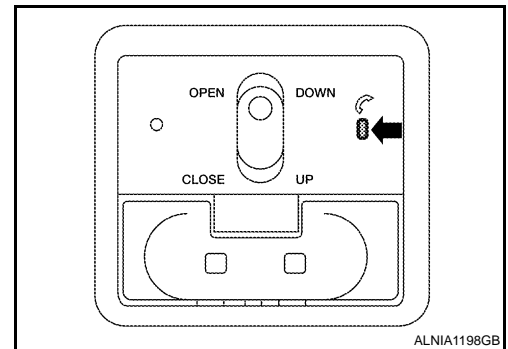

Audio Unit

TELEPHONE

< SERVICE INFORMATION >

The audio unit receives signals from the Bluetooth control unit and sends audio signals to the speakers.

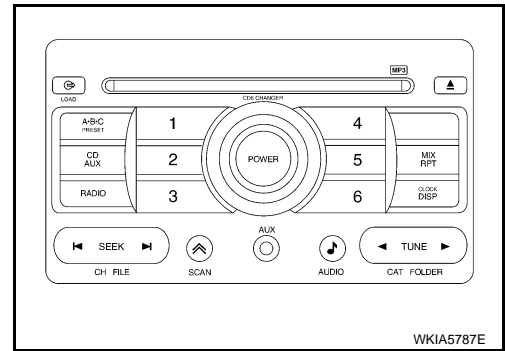

A
B
C
D
E
F
G
H
I
J
AV
L
M
N
O
P

TELEPHONE

< SERVICE INFORMATION >

Wiring Diagram - H/PHON -

INFOID:000000004409453

AV-H/PHON-01

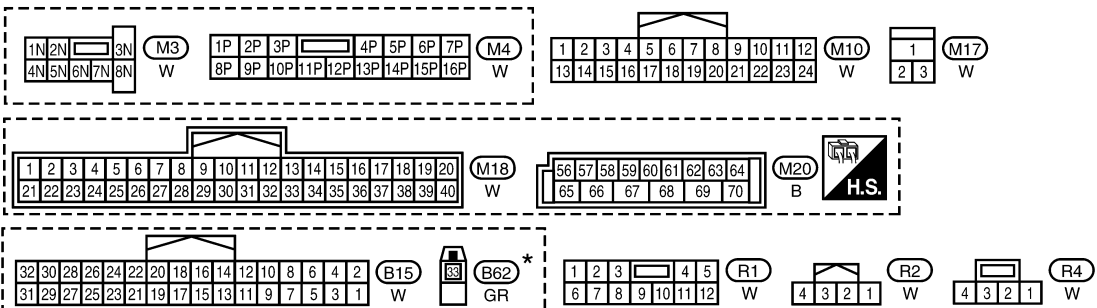
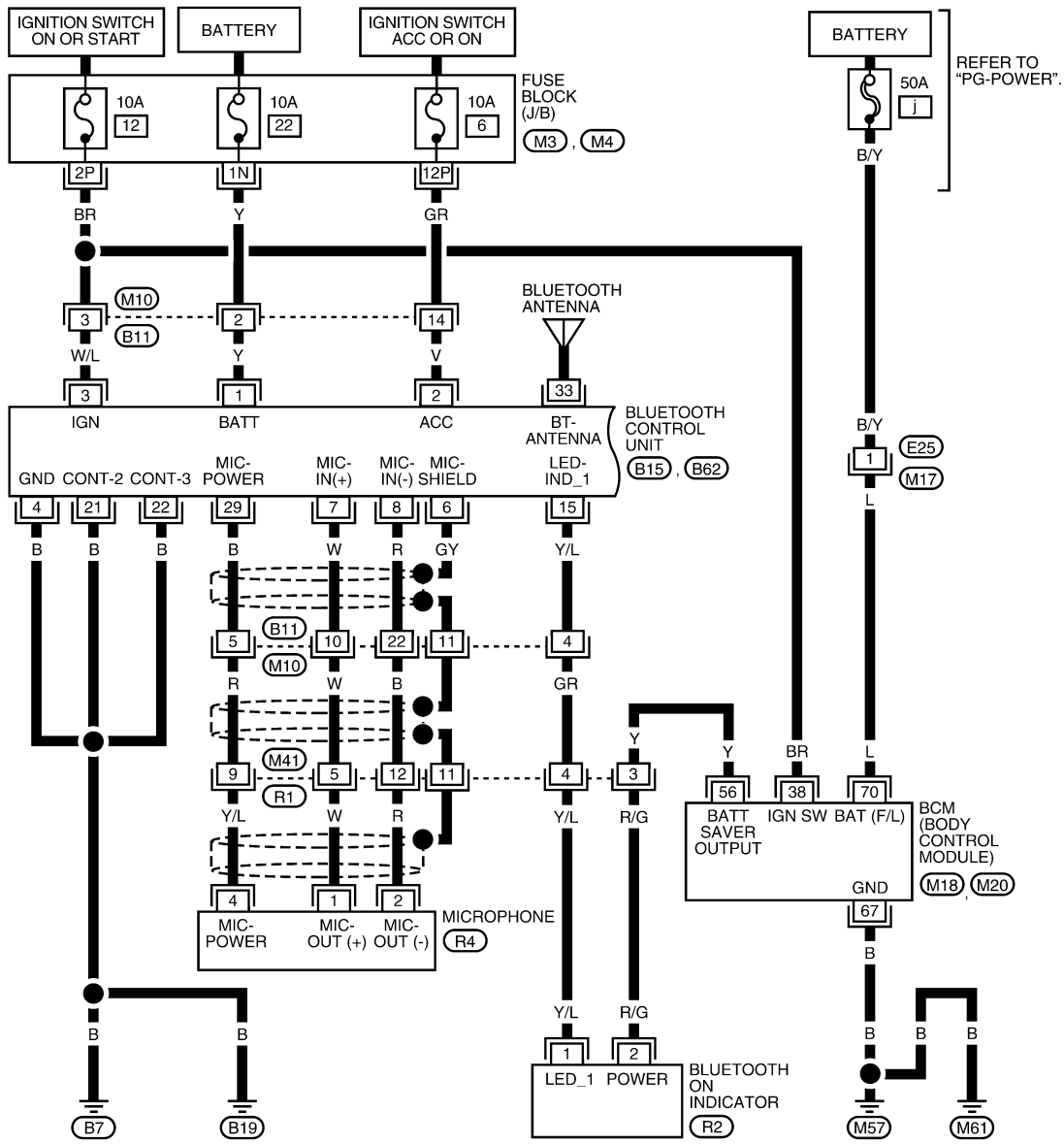

* : THIS CONNECTOR IS NOT SHOWN IN "HARNESS LAYOUT" OF PG SECTION.

AANWA0061GE

TELEPHONE

< SERVICE INFORMATION >

AV-H/PHON-02

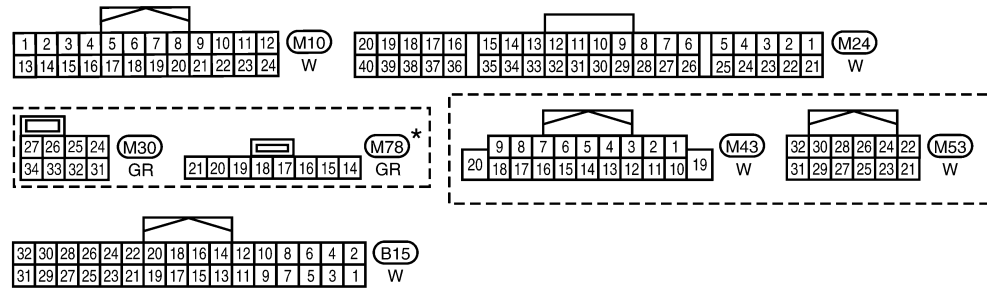
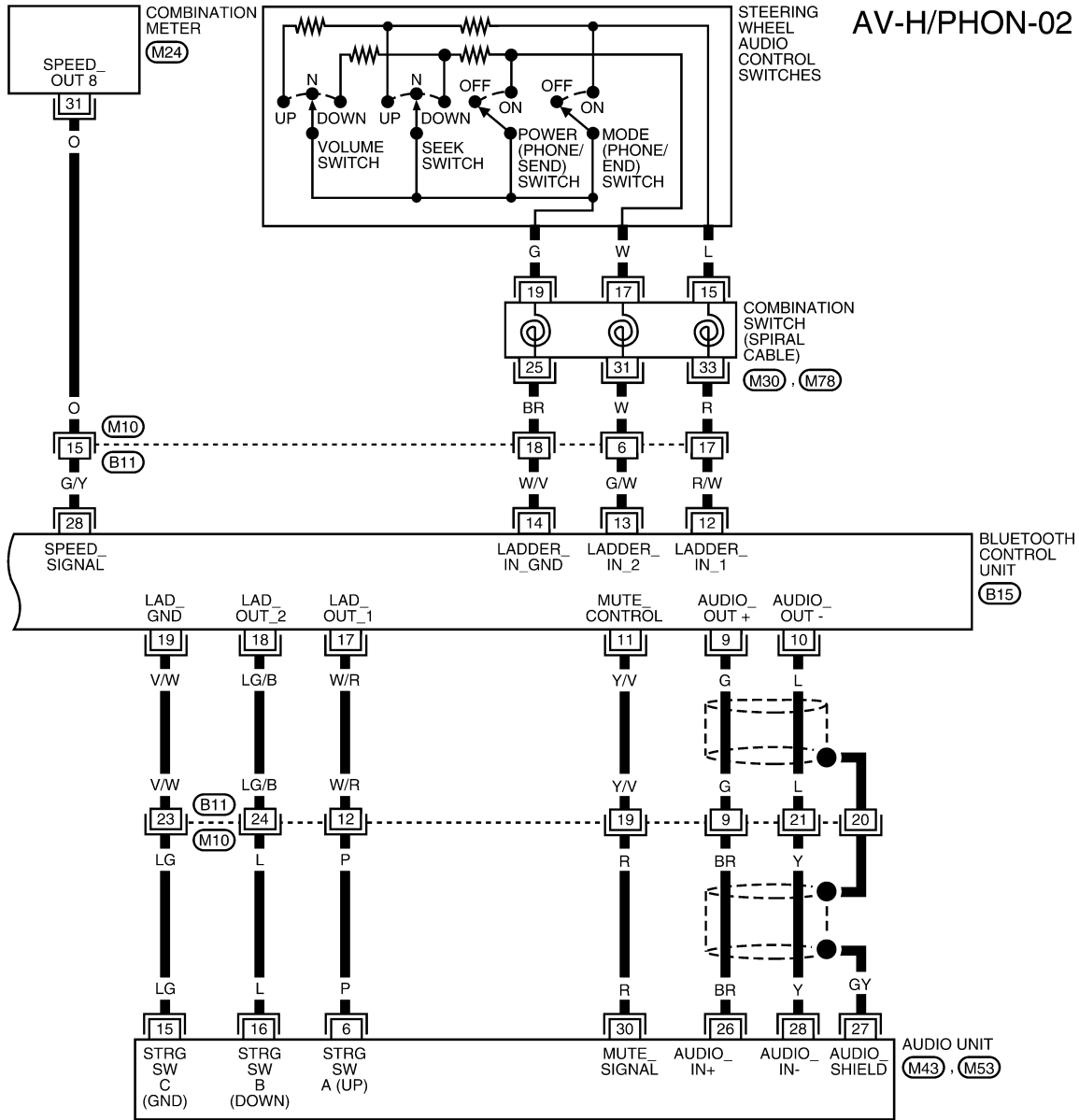

* : THIS CONNECTOR IS NOT SHOWN IN "HARNESS LAYOUT" OF PG SECTION.

AANWA0062GE

A
B
C
D
E
F
G
H
I
J
L
M
N
O
P

AV

TELEPHONE

< SERVICE INFORMATION >

Bluetooth Control Unit Harness Connector Terminal Layout

INFOID:000000004409454

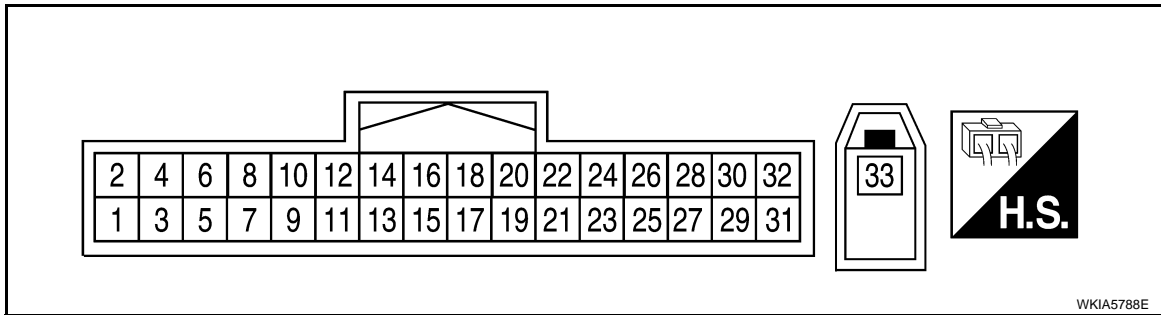

Terminal and Reference Value for Bluetooth Control Unit

INFOID:000000004409455

Terminal (Wire color)		Item	Signal input/ output	Condition		Reference value (Approx.)	Example of symptom
+	-			Ignition switch	Operation		
1 (Y)	Ground	Battery power	Input	-	-	Battery voltage	System does not work properly.
2 (V)	Ground	ACC power	Input	ACC/ ON	-	Battery voltage	System does not work properly.
3 (W/L)	Ground	IGN power	Input	ON/ START	-	Battery voltage	System does not work properly.
4 (B)	-	Ground	-	-	-	-	-
6 (GY)	-	Shield	-	-	-	-	-
7 (W)	8 (R)	Mic-in signal	Input	ACC/ ON	When giving a voice		Bluetooth Microphone inoperative.
9 (G)	10 (L)	Audio out	Output	ACC/ ON	Bluetooth control unit sends audio signal		Audio can not be heard.
11 (Y/V)	-	Mute	Output	-	-	5V	Mute inoperative.
12 (R/W)	Ground	Remote control switch 1	Input	ACC/ ON	Press MODE switch	0V	Steering wheel audio control switches do not function.
					Press SEEK UP switch	0.75V	
					Press VOL UP switch	2V	
					Except for above	5V	

TELEPHONE

< SERVICE INFORMATION >

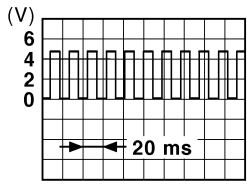
Terminal (Wire color)		Item	Signal input/ output	Condition		Reference value (Approx.)	Example of symptom
+	-			Ignition switch	Operation		
13 (G/W)	Ground	Remote control switch 2	Input	ACC/ ON	Press POWER switch	0V	Steering wheel audio control switches do not function.
					Press SEEK DOWN switch	0.75V	
					Press VOL DOWN switch	2V	
					Except for above	5V	
14 (W/V)	-	Remote control ground	Input	-	-	-	Steering wheel audio control switches do not function.
15 (Y/L)	Ground	Bluetooth ON indicator LED	Output	-	Bluetooth con- trol unit initial- ized and paired with phone	Battery voltage	Bluetooth ON indica- tor inoperative.
17 (W/R)	Ground	Audio unit switch 1	Output	ACC/ ON	Press Phone/ End switch	0V	Steering wheel audio controls do not func- tion.
					Press SEEK UP switch	0.75V	
					Press VOL UP switch	2V	
					Except for above	5V	
18 (LG/B)	Ground	Audio unit switch 2	Output	ACC/ ON	Press Phone/ Send switch	0V	Steering wheel audio controls do not func- tion.
					Press SEEK DOWN switch	0.75V	
					Press VOL DOWN switch	2V	
					Except for above	5V	
19 (V/W)	Ground	Audio unit switch ground	Output	-	-	-	Steering wheel audio controls do not func- tion.
21 (B)	-	Cont-2	-	-	-	-	-
22 (B)	-	Cont-3	-	-	-	-	-
28 (G/Y)	Ground	Vehicle speed signal (8-pulse)	Input	ON	When vehicle speed is approx. 40 km/h (25 MPH)	 <p>(V)</p> <p>6 4 2 0</p> <p>20 ms</p> <p>PKIC0643E</p>	-
29 (B)	Ground	Bluetooth Microphone power	Output	-	-	5V	Bluetooth Micro- phone inoperative.
33	-	Bluetooth antenna sig- nal	Input	-	-	-	-

A
B
C
D
E
F
G
H
I
J
L
M
N
O
P

AV

TELEPHONE

< SERVICE INFORMATION >

Bluetooth Control Unit Self-Diagnosis Function

INFOID:000000004409456

The Bluetooth control unit has two diagnostic checks. The first diagnostic check is performed automatically every ignition cycle during control unit initialization. The second diagnostic check is performed by the technician using the steering wheel audio control switches prior to trouble diagnosis.

BLUETOOTH CONTROL UNIT INITIALIZATION CHECKS

- Internal control unit failure
- Bluetooth antenna connection open or shorted
- Steering wheel audio control switches (SEND/END) stuck closed
- Vehicle speed pulse count
- Bluetooth Microphone connection test (with playback to operator)
- Bluetooth inquiry check

SELF-DIAGNOSIS MODE

1. Turn ignition switch to ACC or ON.
2. Wait for the Bluetooth system to complete initialization and the Bluetooth ON indicator to stop flashing. This may take up to 10 seconds.
3. Press and hold the steering wheel audio control switch SEND button for at least 5 seconds. The Bluetooth system will begin to play a verbal prompt.

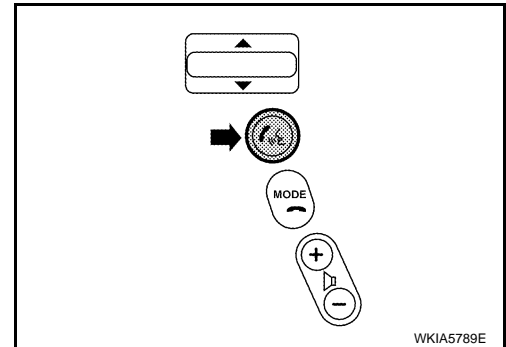

4. While the prompt is playing, momentarily press both the steering wheel audio control switches SEND and END buttons simultaneously. The Bluetooth system will sound a 5 second beep.
5. While the beep is sounding, momentarily press both the steering wheel audio control switches SEND and END buttons simultaneously again.
6. The Bluetooth system has now entered into the diagnostic mode. Results of the diagnostic checks will be verbalized to the technician and the Bluetooth ON indicator will flash. Refer to [AV-67. "Malfunction Code/Symptom Chart"](#).
7. If there are no failure records to report, the speed pulse count will be reported next.
8. After the speed pulse count is reported, an interactive Bluetooth microphone test will be performed. Follow the voice prompt. If the Bluetooth microphone test fails refer to [AV-67. "Malfunction Code/Symptom Chart"](#).
9. Self-diagnosis mode is complete when the voice prompt says "All diagnostic functions completed". A short beep is heard.

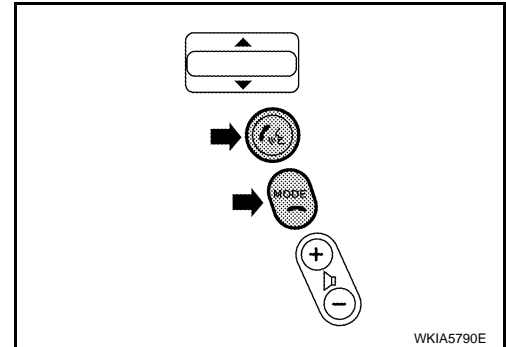

How to Proceed with Trouble Diagnosis

INFOID:000000004409457

1. Confirm the symptom or customer complaint.
2. Perform Bluetooth control unit self-diagnosis. Refer to [AV-66. "Bluetooth Control Unit Self-Diagnosis Function"](#).
3. According to the symptom chart, repair or replace the cause of the symptom. Refer to [AV-67. "Malfunction Code/Symptom Chart"](#).
4. Does the Bluetooth system operate normally? If so, GO TO 5. If not, GO TO 2.
5. Inspection End.

TELEPHONE

< SERVICE INFORMATION >

Malfunction Code/Symptom Chart

INFOID:000000004409458

Code/Symptom	Failure Message	Action
1	"Internal failure"	Replace Bluetooth control unit. Refer to AV-71, "Removal and Installation" .
2	"Bluetooth antenna open"	1. Inspect harness connection. 2. Replace Bluetooth antenna. Refer to AV-71, "Removal and Installation" .
3	"Bluetooth antenna shorted"	
4	"Phone/Send for the Hands Free Phone System is stuck"	Check steering wheel audio control switches. Refer to AV-68, "Steering Wheel Audio Control Switch Does Not Operate" .
5	"Phone/End for the Hands Free Phone System is stuck"	
-	"Bluetooth Microphone test" (failed interactive test)	1. Inspect harness between Bluetooth control unit and Bluetooth microphone. 2. Replace Bluetooth microphone. Refer to AV-71, "Removal and Installation" .
Bluetooth system is inoperative	-	1. Inspect Bluetooth control unit power supply and ground circuits. Refer to AV-67, "Power Supply and Ground Circuit Inspection for Bluetooth Control Unit" . 2. Replace Bluetooth control unit. Refer to AV-71, "Removal and Installation" .
Steering wheel audio control switch does not operate	-	Refer to AV-68, "Steering Wheel Audio Control Switch Does Not Operate" .
Voice activated control does not operate	-	Refer to AV-69, "Voice Activated Control Function Does Not Operate" .

Power Supply and Ground Circuit Inspection for Bluetooth Control Unit

INFOID:000000004409459

1.CHECK FUSES

Make sure the following fuses for the Bluetooth control unit are not blown.

Connector	Terminals		Ignition Switch	Fuse No.
	Terminal			
B15	1		All positions	22
	2		ACC/ON	6
	3		ON/START	12

OK or NG

OK >> GO TO 2.

NG >> If fuse is blown, be sure to eliminate cause of malfunction before installing new fuse. Refer to [PG-3](#).

2.CHECK POWER SUPPLY CIRCUIT

1. Disconnect Bluetooth control unit connector B15.

TELEPHONE

< SERVICE INFORMATION >

- Check voltage between connector terminals and ground as follows.

Terminals		Ignition switch position			
(+)		(-)	OFF	ACC	ON
Connector	Terminal				
B15	1	Ground	Battery voltage	Battery voltage	Battery voltage
	2		0V	Battery voltage	Battery voltage
	3		0V	0V	Battery voltage

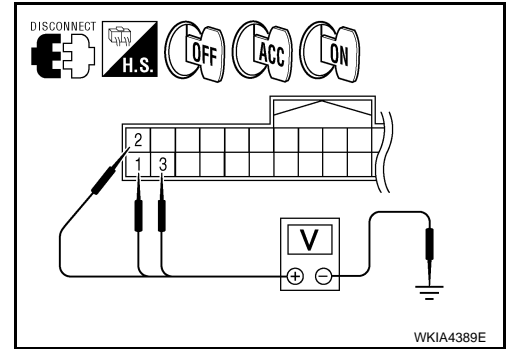

OK or NG

- OK >> GO TO 3.
- NG >> Check harness for open between Bluetooth control unit and fuse.

3.CHECK GROUND CIRCUITS

- Turn ignition switch OFF.
- Check continuity between the following Bluetooth control unit terminals and ground.

Terminals			Continuity
Connector	Terminal	—	
B15	4	Ground	Yes
	21		
	22		

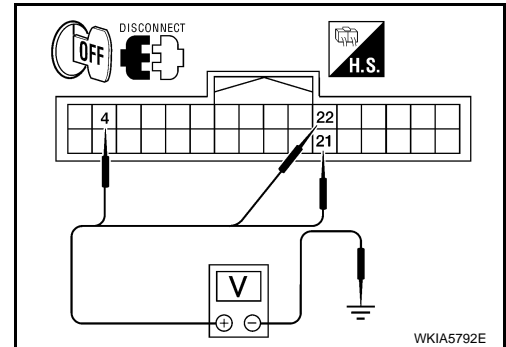

OK or NG

- OK >> Inspection End.
- NG >> Repair or replace harness.

Steering Wheel Audio Control Switch Does Not Operate

INFOID:000000004409460

1.CHECK STEERING WHEEL AUDIO CONTROL SWITCH

Check steering wheel audio control switch. Refer to [AV-40, "Steering Switch Check \(With Bluetooth\)"](#).

OK or NG

- OK >> GO TO 2.
- NG >> Replace steering wheel audio control switch. [AV-51, "Removal and Installation"](#).

2.CHECK AUDIO UNIT

- Turn ignition switch ON.
- Check voltage between audio unit harness connector M43 terminals 6, 16 and ground.

6 - Ground : Approx. 5V
16 - Ground : Approx. 5V

OK or NG

- OK >> Replace audio unit. Refer to [AV-51, "Removal and Installation"](#).
- NG >> GO TO 3.

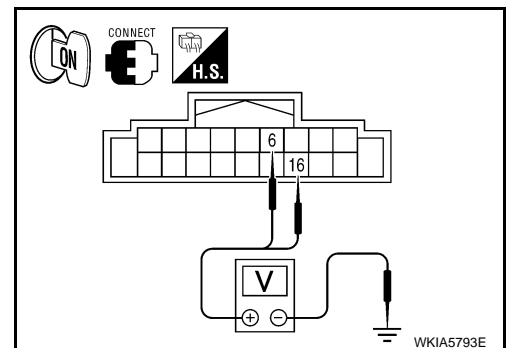

3.CHECK BLUETOOTH CONTROL UNIT

TELEPHONE

< SERVICE INFORMATION >

Check voltage between Bluetooth control unit harness connector B15 terminals 17, 18 and ground.

- 17 - Ground : Approx. 5V**
- 18 - Ground : Approx. 5V**

OK or NG

- OK >> Repair or replace harness.
- NG >> Replace Bluetooth control unit. [AV-71, "Removal and Installation"](#).

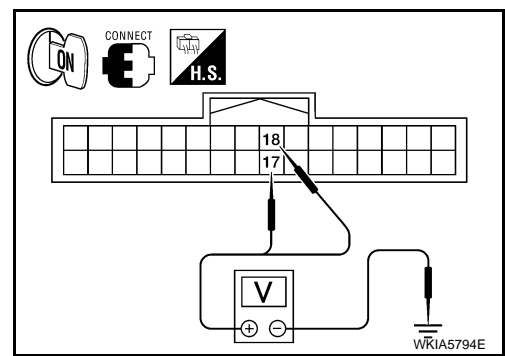

Voice Activated Control Function Does Not Operate

INFOID:000000004409461

NOTE:

Even under normal condition, Bluetooth voice guidance may not occur when pressing steering wheel audio control switch.

BLUETOOTH VOICE GUIDANCE IS HEARD WHEN PRESSING STEERING WHEEL AUDIO CONTROL SWITCH

1. CHECK HARNESS BETWEEN BLUETOOTH CONTROL UNIT AND MICROPHONE

1. Turn ignition switch OFF.
2. Disconnect Bluetooth control unit connector and microphone connector.
3. Check continuity between Bluetooth control unit connector B15 (A) and microphone connector R4 (B).

Terminals				Continuity
Connector	Terminal	Connector	Terminal	
A: B15	7	B: R4	1	Yes
	8		2	
	29		4	

4. Check continuity between Bluetooth control unit harness connector B15 and ground.

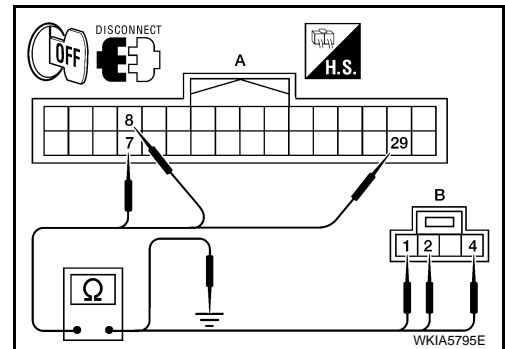

Terminals			Continuity
Connector	Terminal	—	
A: B15	7	Ground	No
	8		
	29		

OK or NG

- OK >> GO TO 2.
- NG >> Repair harness or connector.

2. CHECK MICROPHONE POWER SUPPLY

1. Connect Bluetooth control unit connector and microphone connector.
2. Turn ignition switch ON.

TELEPHONE

< SERVICE INFORMATION >

- Check voltage between microphone connector R4 terminal 4 and ground.

4 - Ground : Approx. 5V

OK or NG

- OK >> GO TO 3.
- NG >> Replace Bluetooth control unit. Refer to [AV-71, "Removal and Installation"](#).

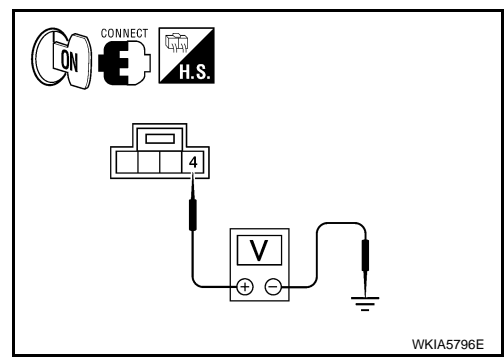

3. CHECK MICROPHONE SIGNAL

Check signal between Bluetooth control unit harness connector B15 terminals 7 and 8.

When giving a voice

7 - 8:

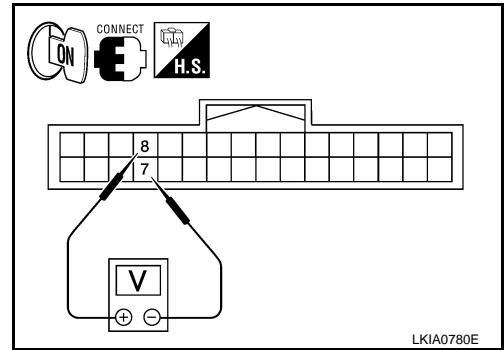
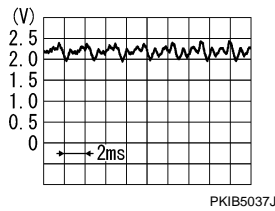

OK or NG

- OK >> Replace Bluetooth control unit. Refer to [AV-71, "Removal and Installation"](#).
- NG >> Replace microphone. Refer to [AV-71, "Removal and Installation"](#).

BLUETOOTH VOICE GUIDANCE IS NOT HEARD WHEN PRESSING STEERING WHEEL AUDIO CONTROL SWITCH

1. CHECK STEERING WHEEL AUDIO CONTROL SWITCH CIRCUIT

Refer to [AV-68, "Steering Wheel Audio Control Switch Does Not Operate"](#).

OK or NG

- OK >> GO TO 2.
- NG >> Replace applicable parts.

2. CHECK BLUETOOTH VOICE SIGNAL CIRCUIT

- Turn ignition switch OFF.
- Disconnect Bluetooth control unit connector and audio unit connector.
- Check continuity between Bluetooth control unit harness connector B15 (A) and audio unit harness connector M53 (B).

Terminals				Continuity
Connector	Terminal	Connector	Terminal	
A: B15	9	B: M53	26	Yes
	10		28	
	11		30	

- Check continuity between Bluetooth control unit harness connector B15 (A) and ground.

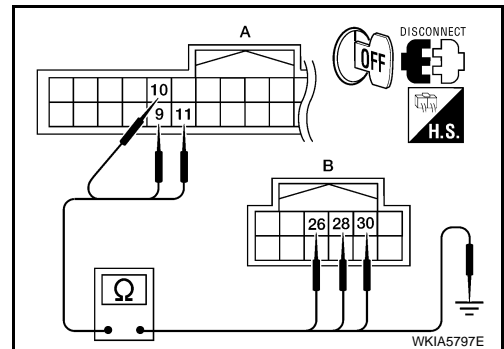

TELEPHONE

< SERVICE INFORMATION >

Terminals			Continuity
Connector	Terminal	—	
A: B15	9	Ground	No
	10		
	11		

OK or NG

- OK >> GO TO 3.
- NG >> Repair harness or connector.

3. CHECK MUTE SIGNAL

1. Connect Bluetooth control unit connector and audio unit connector.
2. Turn ignition switch ON.
3. Check voltage between Bluetooth control unit connector B15 terminal 11 and ground.

11 - Ground : Approx. 5V

OK or NG

- OK >> GO TO 4.
- NG >> Replace audio unit. Refer to [AV-51, "Removal and Installation"](#).

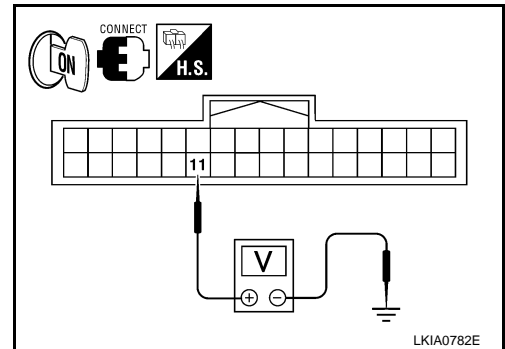

4. CHECK BLUETOOTH VOICE SIGNAL

Check signal between Bluetooth control unit harness connector B15 terminals 9 and 10.

When giving a voice

9 - 10:

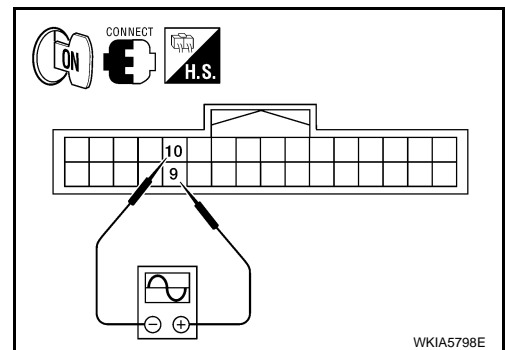
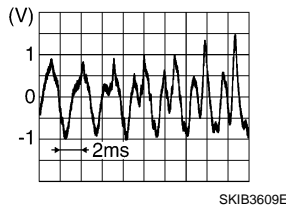

OK or NG

- OK >> Replace audio unit. Refer to [AV-51, "Removal and Installation"](#).
- NG >> Replace Bluetooth control unit. Refer to [AV-71, "Removal and Installation"](#).

Removal and Installation

INFOID:000000004409462

COMPONENTS

TELEPHONE

< SERVICE INFORMATION >

Bluetooth Control Unit and Antenna

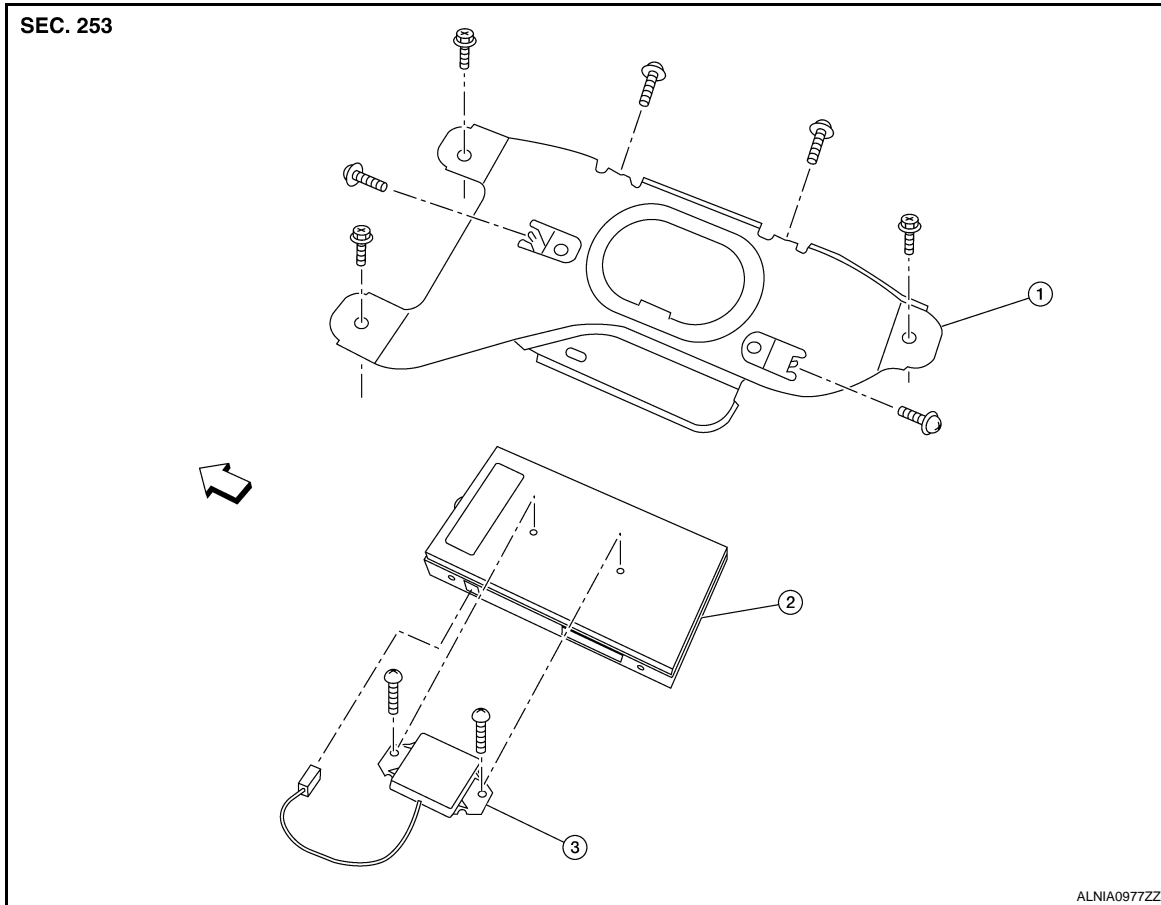

1. Bluetooth control unit bracket

2. Bluetooth control unit

3. Bluetooth antenna

← Front

BLUETOOTH CONTROL UNIT

Removal

NOTE:

Bluetooth control unit shown with the LH seat removed for clarity.

1. Slide the LH front seat toward the front to remove the bluetooth control unit bracket rear bolt (A).
2. Slide the LH front seat toward the rear to remove the bluetooth control unit bracket front bolts (A).
3. Detach the Bluetooth control unit harness clip (B) from the Bluetooth control unit bracket.
4. Disconnect the Bluetooth control unit connector (C).
5. Remove the Bluetooth control unit and bracket assembly (1).
6. Remove the Bluetooth control unit screws and remove the Bluetooth control unit.

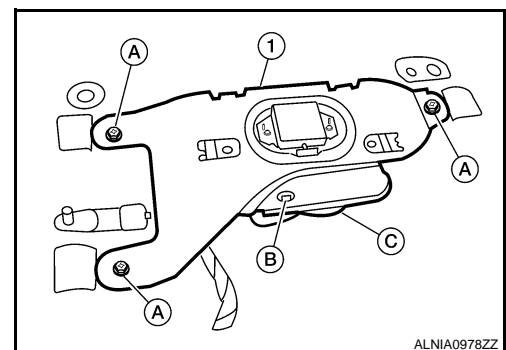

Installation

Installation is in the reverse order of removal.

BLUETOOTH ANTENNA

Removal

NOTE:

Bluetooth antenna is mounted on top of the Bluetooth control unit.

1. Slide the LH front seat toward the rear.
2. Disconnect the Bluetooth antenna connector.

TELEPHONE

< SERVICE INFORMATION >

3. Remove the Bluetooth antenna screws and remove the Bluetooth antenna.

Installation

Installation is in the reverse order of removal.

BLUETOOTH MICROPHONE

Removal

1. Remove the map lamp. Refer to [LT-81, "Map Lamp"](#).
2. Remove the Bluetooth microphone.

Installation

Installation is in the reverse order of removal.

A

B

C

D

E

F

G

H

I

J

AV

L

M

N

O

P

INTEGRATED DISPLAY SYSTEM

< SERVICE INFORMATION >

INTEGRATED DISPLAY SYSTEM

Component Parts and Harness Connector Location

INFOID:000000004409463

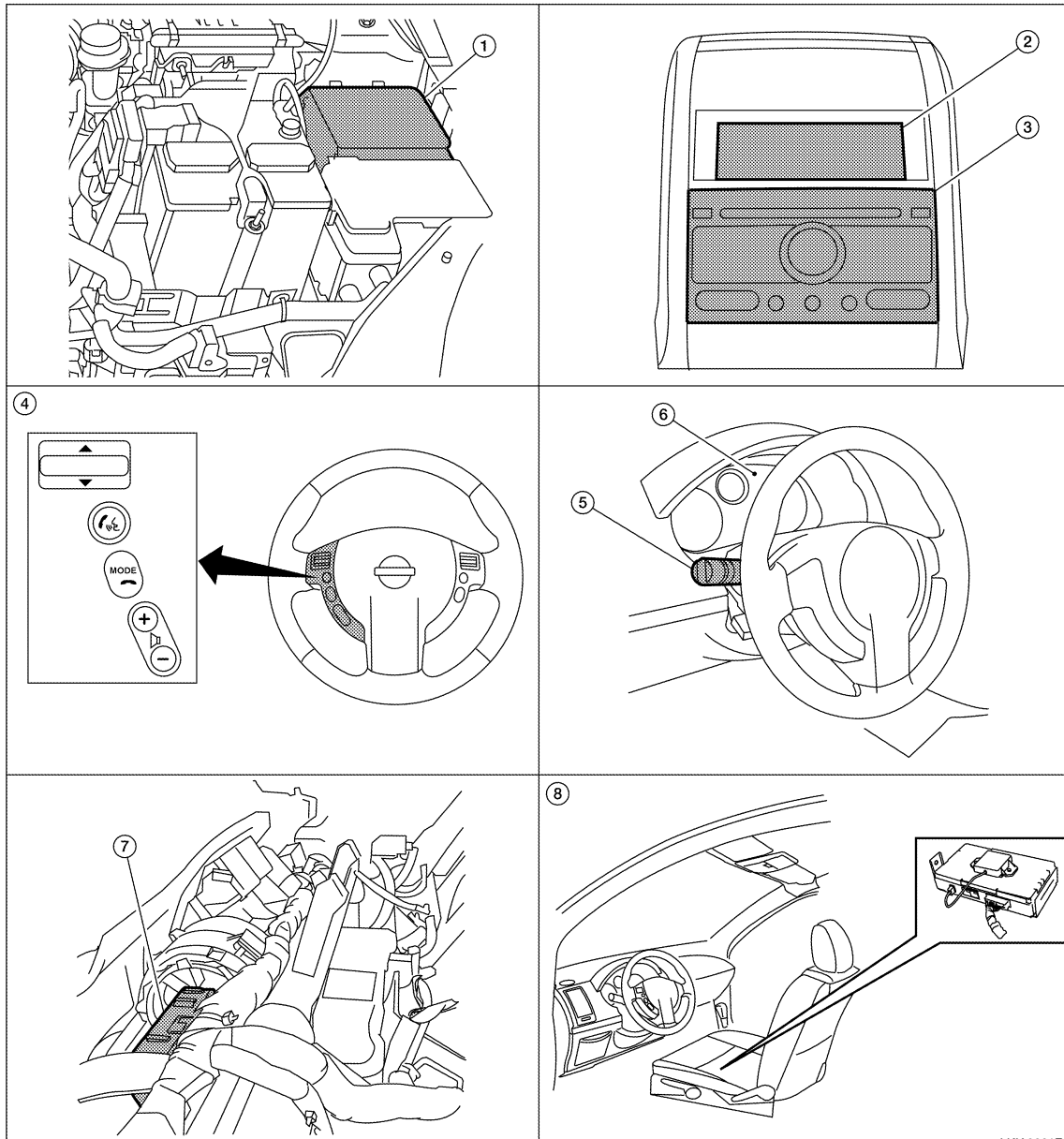

LKIA0861E

- | | | |
|--|--|-----------------------------|
| 1. IPDM E/R E46, E48 | 2. Display unit | 3. Audio unit M43, M53, M79 |
| 4. Steering wheel audio control switches (if equipped) | 5. Combination switch M28 | 6. Combination meter M24 |
| 7. BCM M18, M20 (view with instrument panel removed) | 8. Bluetooth control unit B15 (with Bluetooth) | |

System Description

INFOID:000000004409464

PRECAUTION OF LCD MONITOR

- Brightness of LED backlight display may change, depending on in-car temperature. In low temperatures, the refreshing rate of the picture also becomes low because of the low response of the LCD monitor. When passenger area becomes warm, however, the LCD recovers the normal display.
- Backlight sometimes flickers or darkens according to the total operation hours and the number of times switched ON and OFF. In this case, entire display unit should be replaced. (Backlight cannot be replaced separately.)

INTEGRATED DISPLAY SYSTEM

< SERVICE INFORMATION >

POWER SUPPLY AND GROUND

Power is supplied at all times

- through 20A fuse (No. 31, located in fuse and fusible link box)
- to audio unit terminal 19,
- through 15A fuse (No. 52, located in the IPDM E/R)
- to CPU of the IPDM E/R,
- through 20A fuse (No. 53, located in the IPDM E/R)
- to CPU of the IPDM E/R,
- through 50A fusible link (letter j, located in the fuse and fusible link box)
- to BCM terminal 70,
- through 10A fuse [No. 21, located in the fuse block (J/B)]
- to BCM terminal 57.

When the ignition switch is in ACC or ON position, power is supplied

- through 10A fuse [No. 6, located in fuse block (J/B)]
- to audio unit terminal 7 and
- to BCM terminal 11.

When the ignition switch is in ON or START position, power is supplied

- to ignition relay located in the IPDM E/R,
- through 10A fuse [No. 12, located in fuse block (J/B)]
- to BCM terminal 38.

Ground is supplied

- to BCM terminal 67
- through body grounds M57 and M61,
- to IPDM E/R terminals 39 and 59
- through body grounds E9, E15 (all models) and E24 (with MR20DE).

DRIVE COMPUTER

Refer to Owner's Manual for drive computer operating instructions.

CAN COMMUNICATION SYSTEM DESCRIPTION

Refer to [LAN-6, "System Description"](#).

A

B

C

D

E

F

G

H

I

J

AV

L

M

N

O

P

INTEGRATED DISPLAY SYSTEM

< SERVICE INFORMATION >

Schematic

INFOID:000000004409465

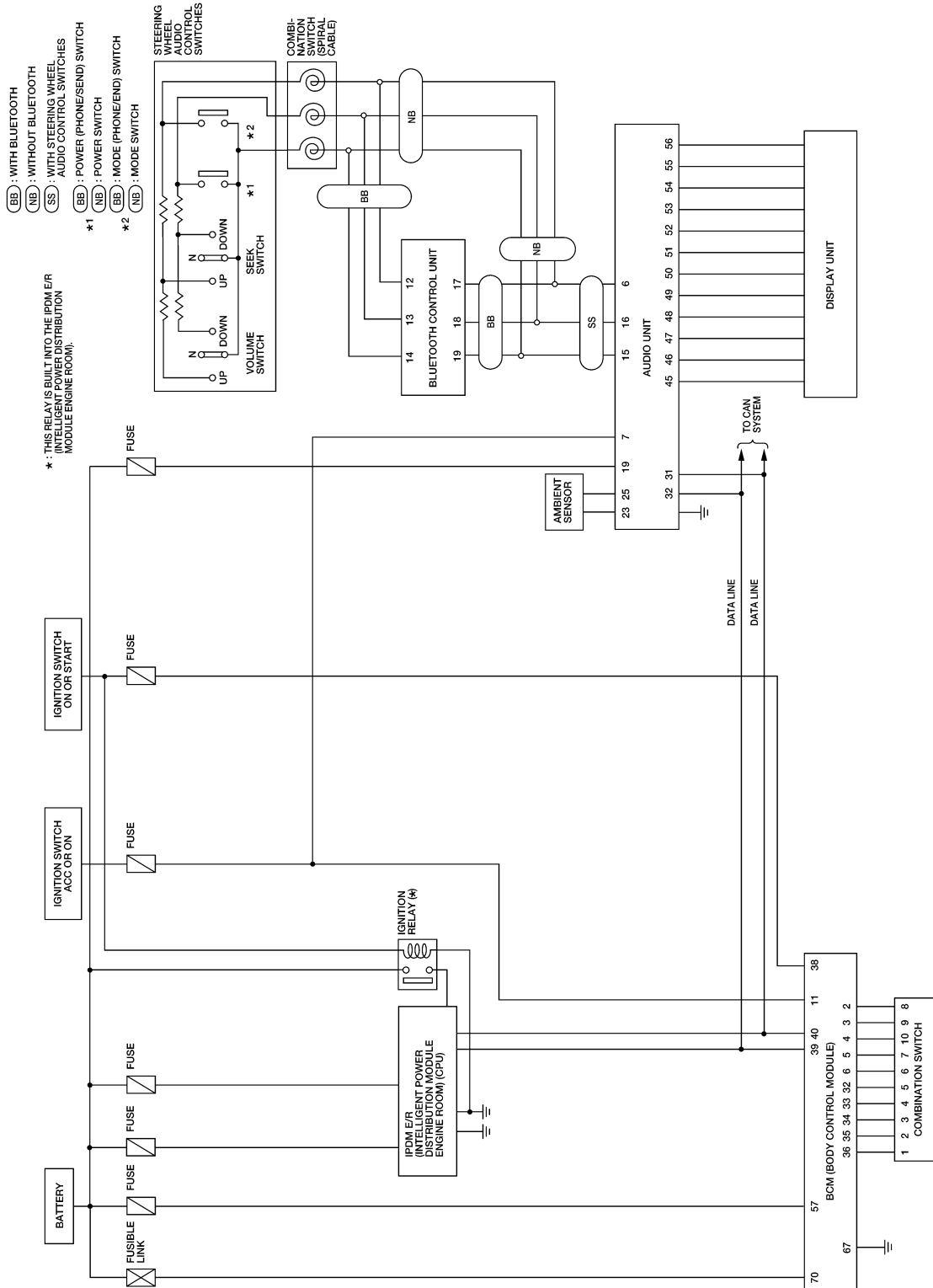

ABNWA0288Gf

INTEGRATED DISPLAY SYSTEM

< SERVICE INFORMATION >

Wiring Diagram - INF/D -

INFOID:000000004409466

AV-INF/D-01

▬ : DATA LINE
 ◀MR▶ : WITH MR20DE

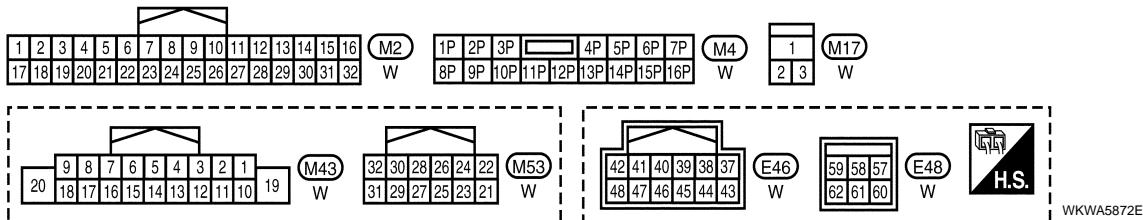
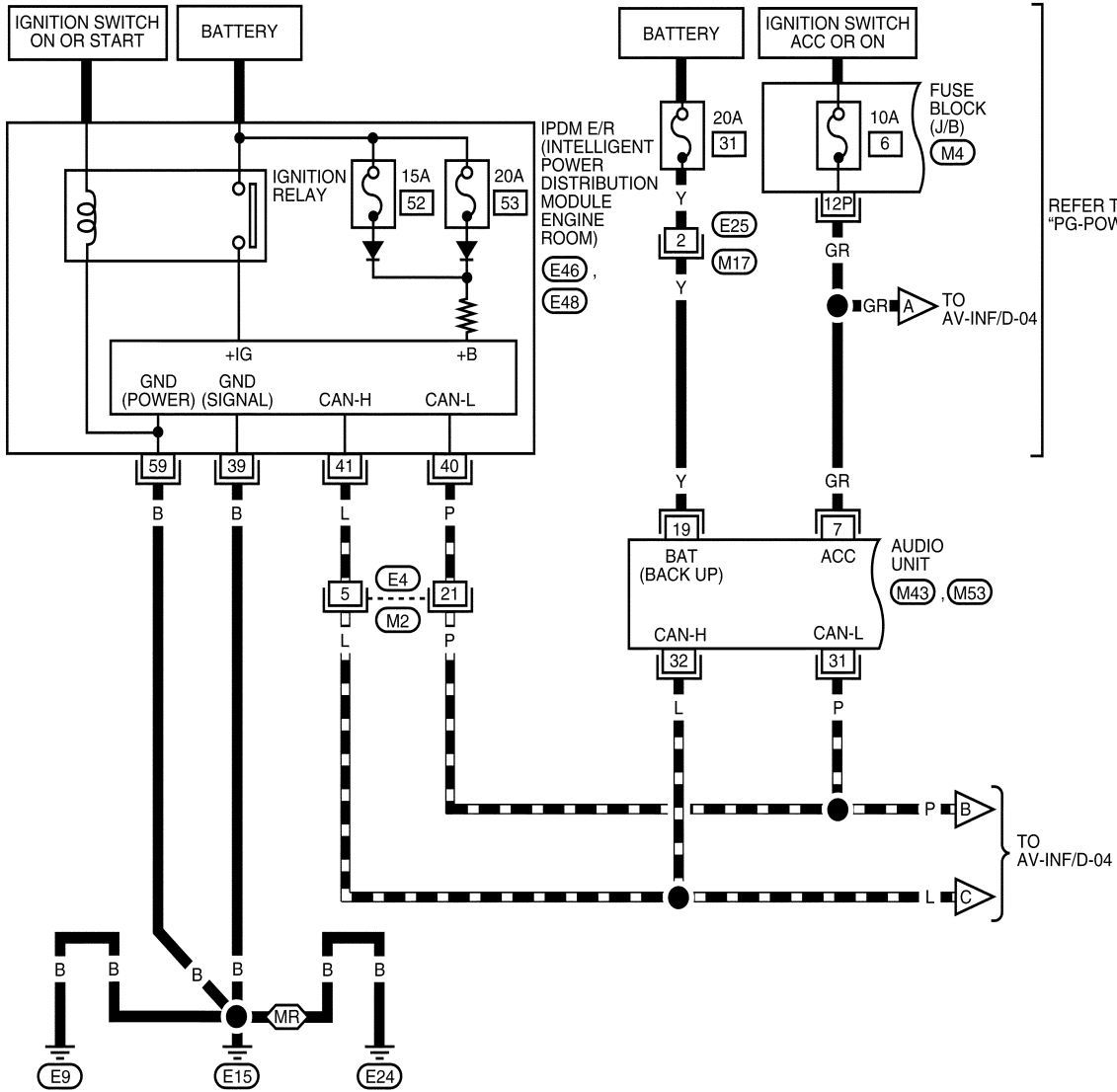

WKWA5872E

INTEGRATED DISPLAY SYSTEM

< SERVICE INFORMATION >

WITHOUT BLUETOOTH

AV-INF/D-02

Ⓢ : WITH STEERING WHEEL AUDIO CONTROL SWITCHES

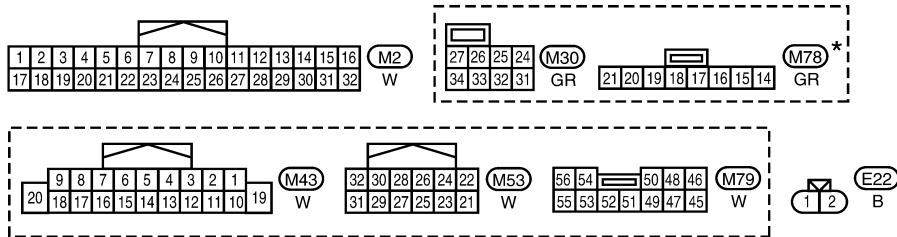
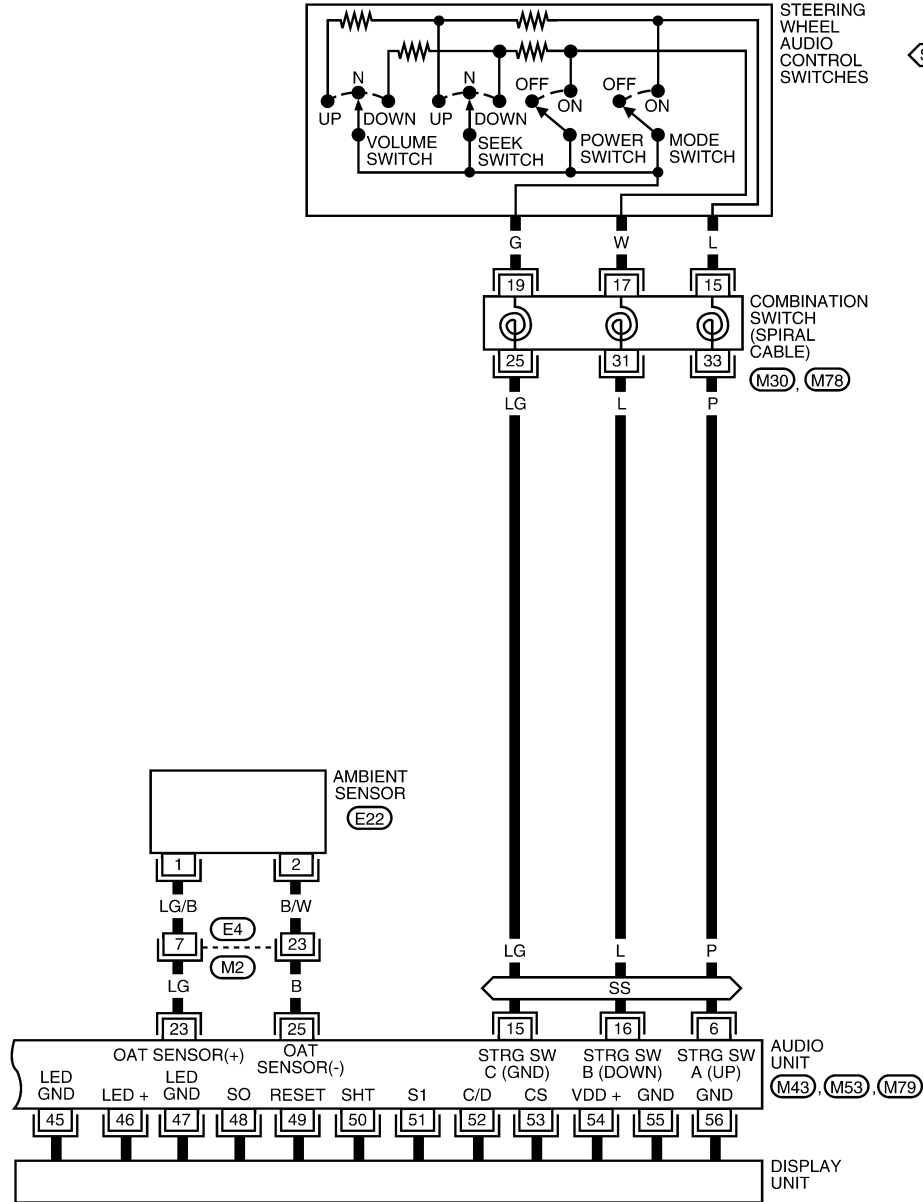

* : THIS CONNECTOR IS NOT SHOWN IN "HARNESS LAYOUT" OF PG SECTION.

ABNWA0290GE

INTEGRATED DISPLAY SYSTEM

< SERVICE INFORMATION >

WITH BLUETOOTH

AV-INF/D-03

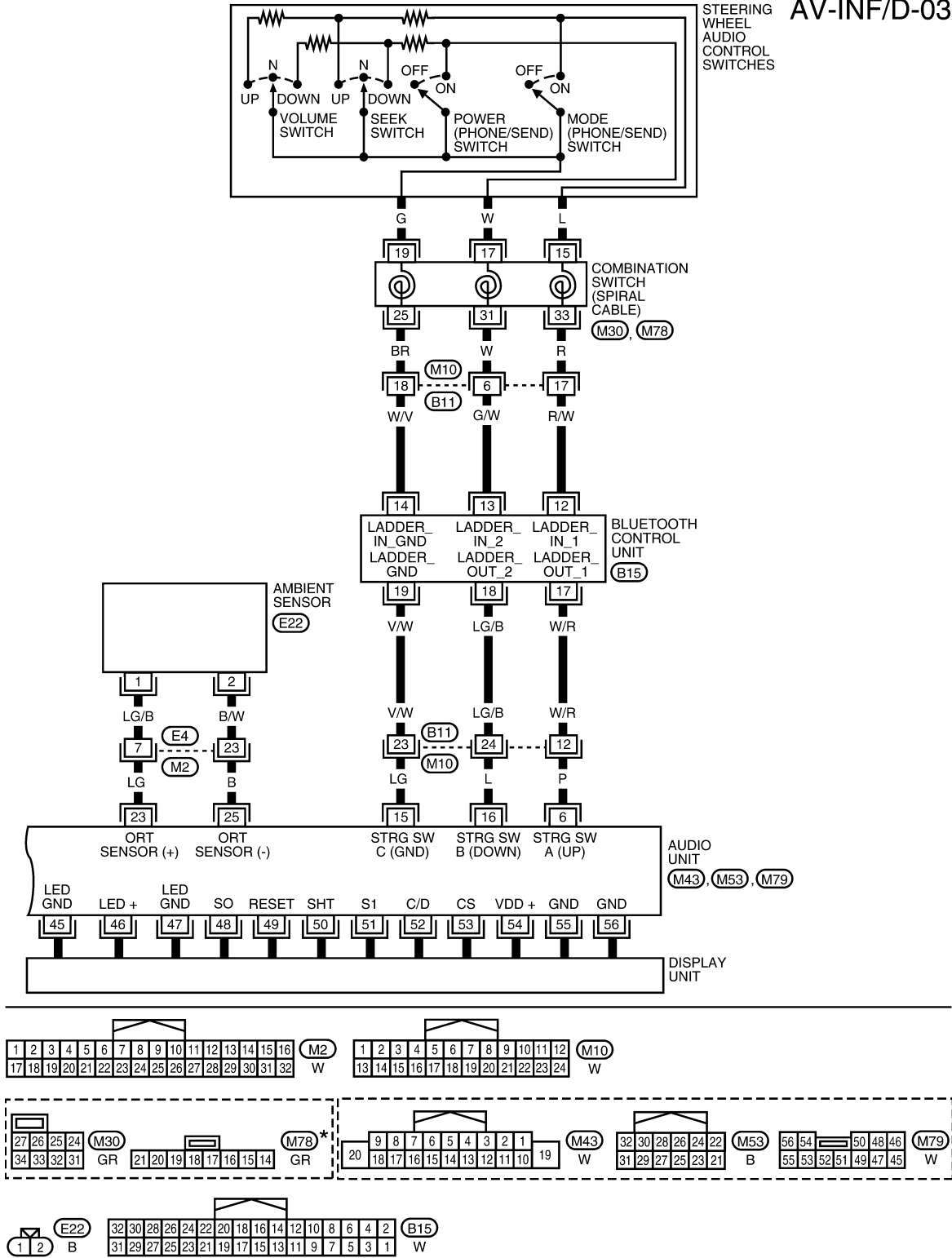

*: THIS CONNECTOR IS NOT SHOWN IN "HARNESS LAYOUT" OF PG SECTION.

BKWA0775E

INTEGRATED DISPLAY SYSTEM

< SERVICE INFORMATION >

AV-INF/D-04

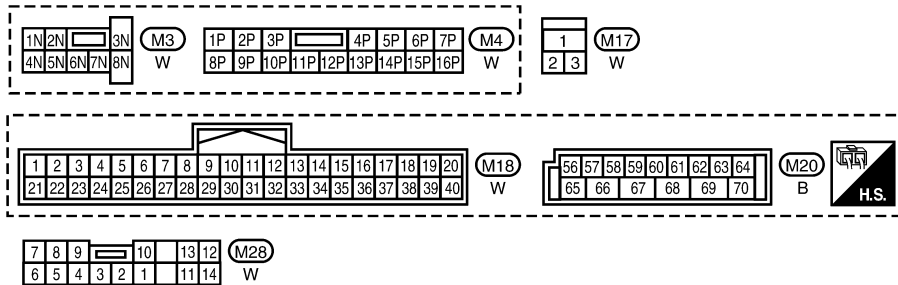
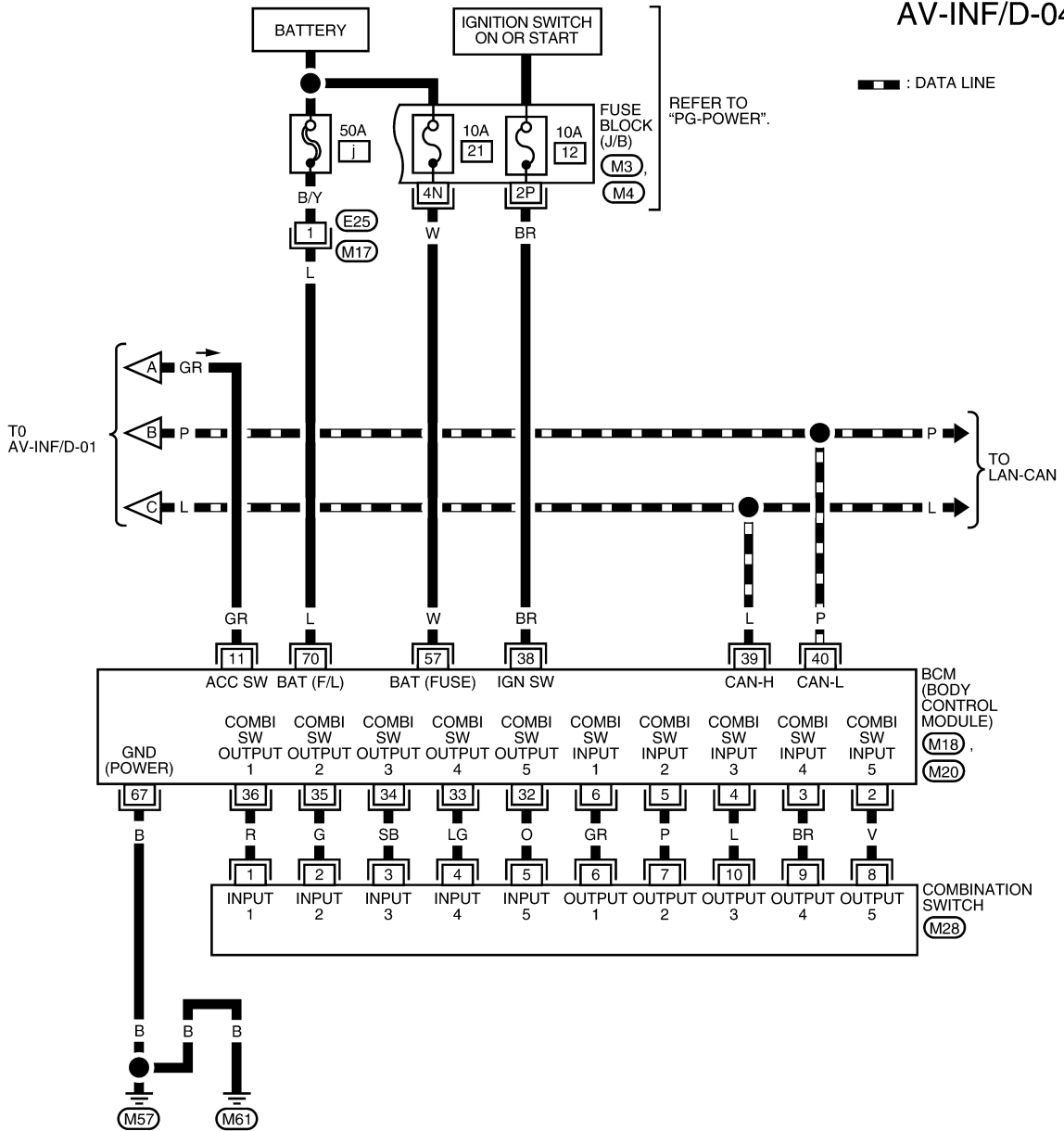

BKWA0776E

INTEGRATED DISPLAY SYSTEM

< SERVICE INFORMATION >

Wiring Diagram - COMM -

INFOID:000000004409467

AV-COMM-01

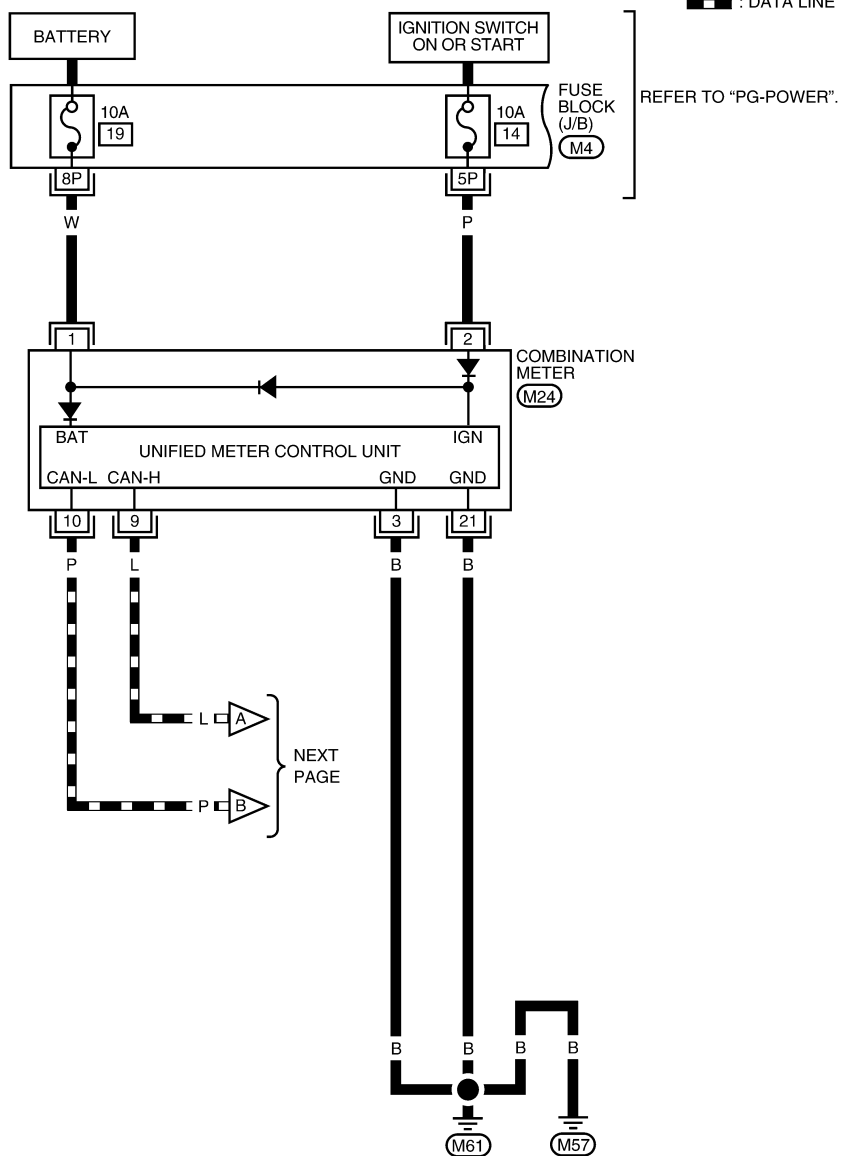

1P	2P	3P	4P	5P	6P	7P	(M4)	20	19	18	17	16	15	14	13	12	11	10	9	8	7	6	5	4	3	2	1	(M24)		
8P	9P	10P	11P	12P	13P	14P	15P	16P	W	40	39	38	37	36	35	34	33	32	31	30	29	28	27	26	25	24	23	22	21	W

AWKWA0094GI

A
B
C
D
E
F
G
H
I
J
AV
L
M
N
O
P

INTEGRATED DISPLAY SYSTEM

< SERVICE INFORMATION >

AV-COMM-02

— : DATA LINE

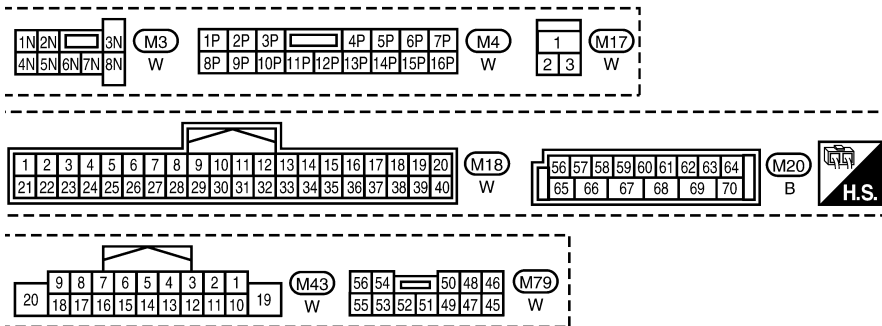
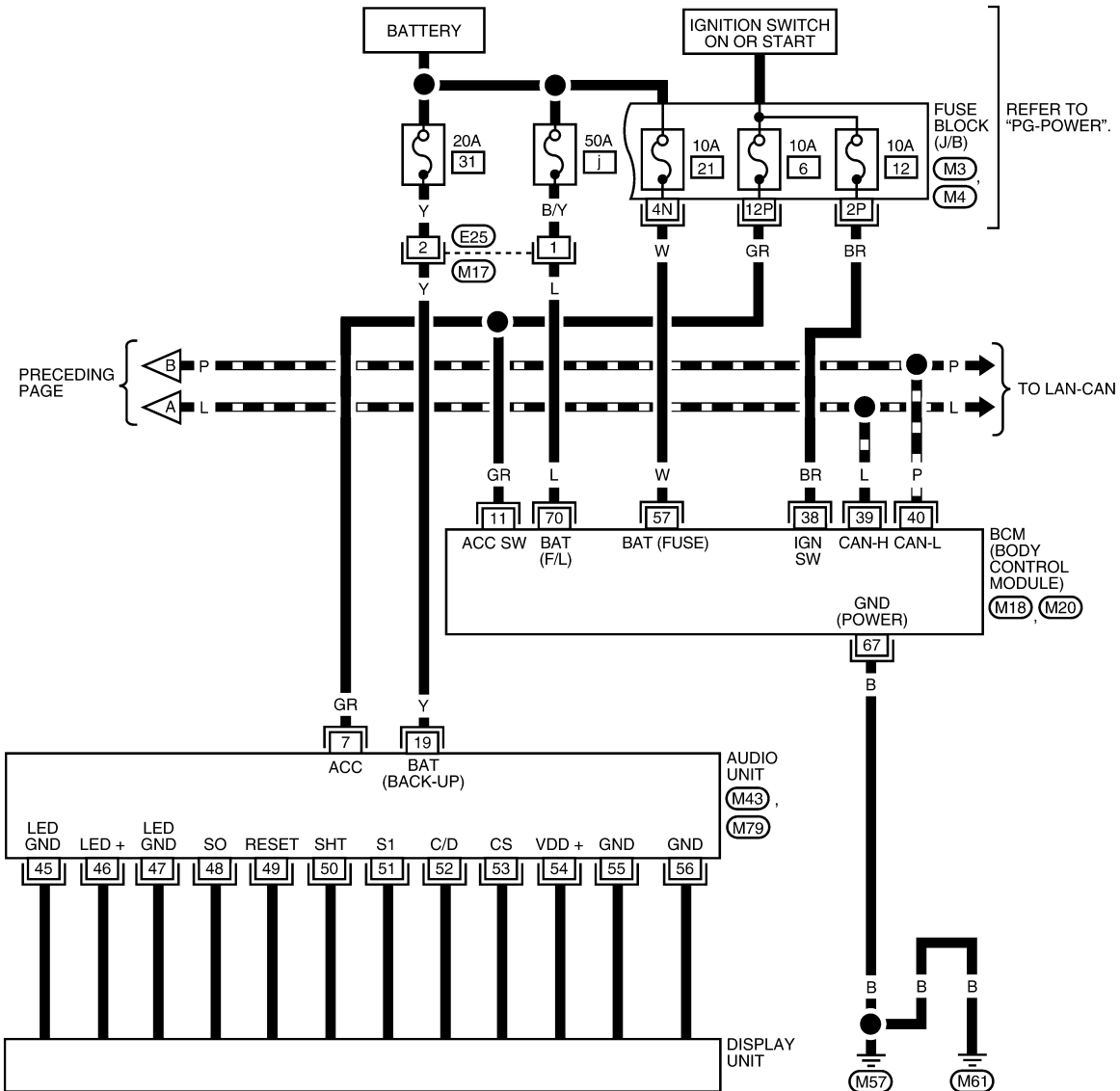

BKWA0778E

On Board Self-Diagnosis Function

INFOID:000000004409468

DESCRIPTION

- Diagnosis function consists of the self-diagnosis mode performed automatically.
- Self-diagnosis mode checks for connections between the units constituting this system, analyzes each individual unit at the same time, and displays the results on the LCD screen.

DIAGNOSIS ITEM

INTEGRATED DISPLAY SYSTEM

< SERVICE INFORMATION >

Mode	Item	Description	Reference page
Self-diagnosis	VERSION CHECK	Displays version of each unit.	AV-83, "Self-Diagnosis Mode"
	CHANNEL CHECK	Performs self-diagnosis for audio system speaker channels.	AV-83, "Self-Diagnosis Mode"
	BUTTON CHECK	Displays name of each switch as it is pressed.	AV-83, "Self-Diagnosis Mode"
	CAN CHECK	Displays CAN communication status.	AV-83, "Self-Diagnosis Mode"

Self-Diagnosis Mode

INFOID:000000004409469

OPERATION PROCEDURES

1. Start the engine.
2. Turn the audio system off.
3. While pressing the "SCAN" button, turn the volume control dial clockwise or counterclockwise for 30 clicks or more. When the self-diagnosis mode is started a short beep will be heard.
4. When the self-diagnosis mode is started all of the display segments will be illuminated.

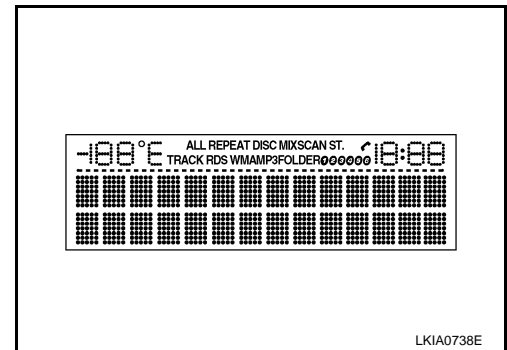
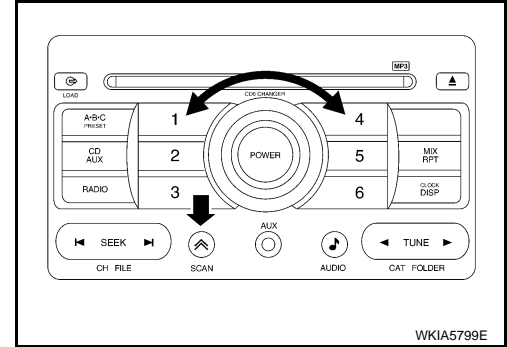

VERSION CHECK

1. Press the "AUDIO" switch to enter version diagnostics. Press "AUDIO" switch again to display the "Software Ver:" (audio software version).

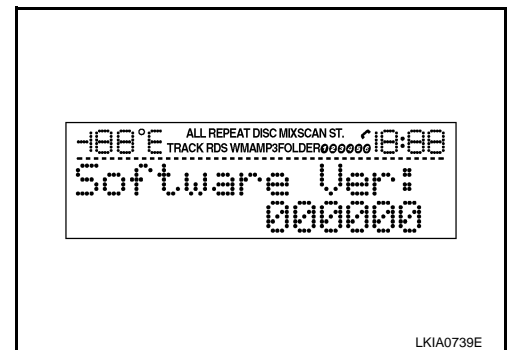

INTEGRATED DISPLAY SYSTEM

< SERVICE INFORMATION >

2. Press "AUDIO" switch again to display the "Hardware Ver:" (audio hardware version).

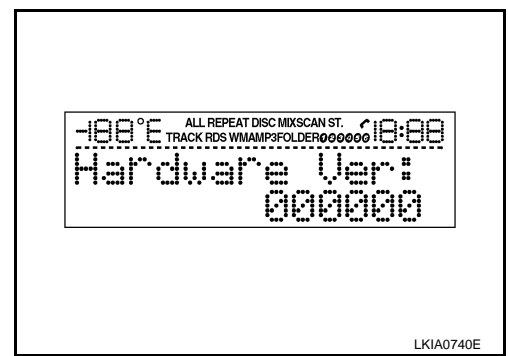

3. Press "AUDIO" switch again to display the "CD Mech Ver:" (CD mechanism version).

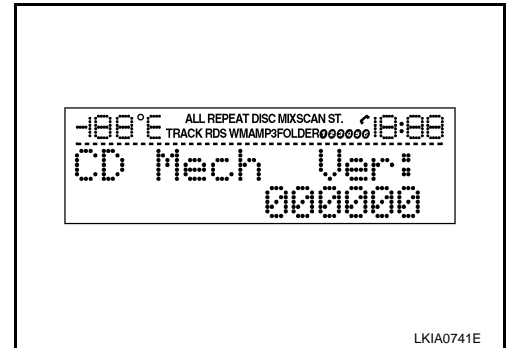

4. Press "AUDIO" switch again to display the "SDARS Ver:" (satellite radio tuner version).

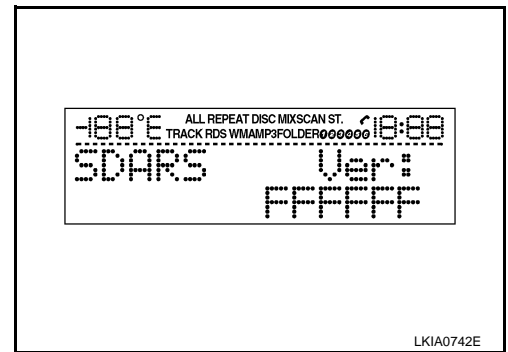

CHANNEL CHECK DIAGNOSTICS

Press the "TUNE" up switch to enter channel check diagnostics. The self-diagnosis function will then display each of the four channels (FL, FR, RL, RR) for 1 second while sending a tone to each channel displayed.

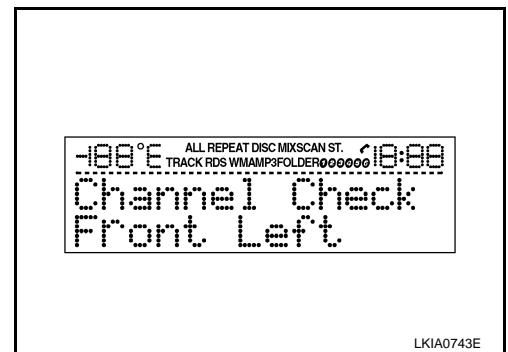

BUTTON CHECK DIAGNOSTICS

INTEGRATED DISPLAY SYSTEM

< SERVICE INFORMATION >

Press the "TUNE" down switch to enter button check diagnostics. Pressing each individual switch will display that switch's name.

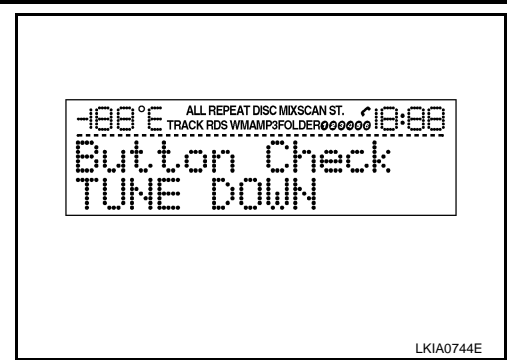

CAN CHECK DIAGNOSTICS

1. Press and hold the "AUDIO" switch for more than 1.5 seconds to enter "CAN check diagnostics". Pressing the "AUDIO" switch again will toggle through "ECM", "METER", and "BCM".
 - If a current diagnostic result is detected "UN" will be displayed under the heading PR (present)
 - If no current diagnostic result is detected "OK" will be displayed under the heading PR (present)
 - If a past diagnostic result is detected 39 - 0 will be displayed under the heading PA (past), indicating the number of key cycles since that diagnostic result was detected
2. Pressing "AUDIO" again will display "Do You Want To Delete?" If you do not wish to delete any diagnostic results, or no diagnostic results exist, pressing "AUDIO" again will display "Key Failure 1 Not Found". After 6 seconds the display will return to the CAN check diagnostics screen.

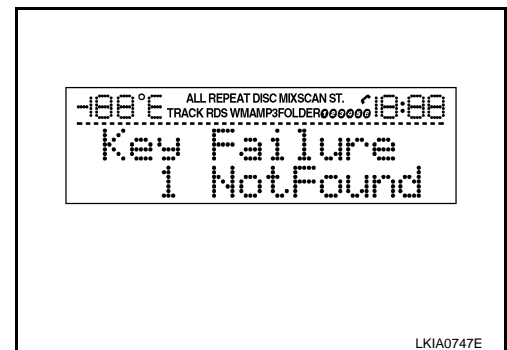
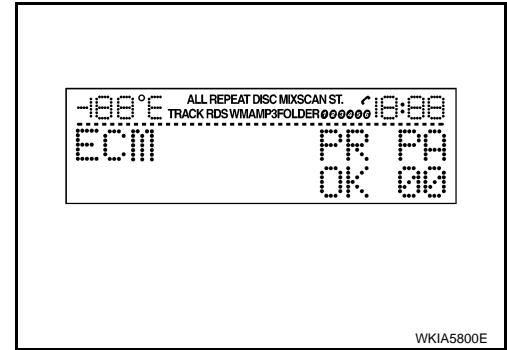

A
B
C
D
E
F
G
H
I
J
AV
L
M
N
O
P

INTEGRATED DISPLAY SYSTEM

< SERVICE INFORMATION >

3. To delete diagnostic items press "TUNE" to display all diagnostic items then press "TUNE" up/down to select the desired diagnostic item, "Deletion #" will be displayed.

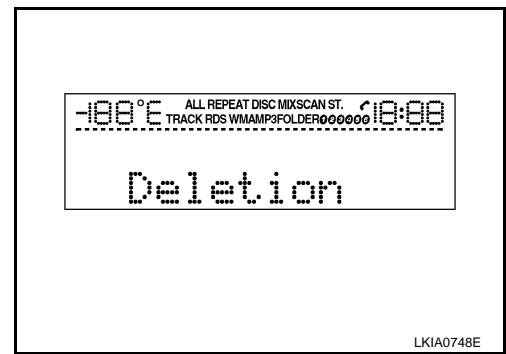

4. Press and hold the "SCAN" switch for more than 6 seconds to delete the desired diagnostic item. "Failure Data Reset" will be displayed, followed by a return to the "CAN check diagnostics" screen.

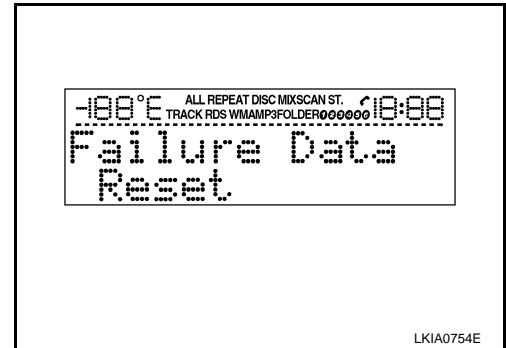

Trouble Diagnosis Chart by Symptom

INFOID:000000004409470

Symptom	Suspect Systems and reference
No screen is shown.	Refer to AV-22, "Terminal and Reference Value for Audio Unit (Mid System)" or AV-25, "Terminal and Reference Value for Audio Unit (Premium System)" . If above is normal, replace display unit. Refer to AV-86, "Removal and Installation" .
Screen does not switch to nighttime mode after the lighting switch is turned to 1st.	Refer to AV-22, "Terminal and Reference Value for Audio Unit (Mid System)" or AV-25, "Terminal and Reference Value for Audio Unit (Premium System)" . If above is normal, replace display unit. Refer to AV-86, "Removal and Installation" .
Trip time screen does not appear.	Replace display unit. Refer to AV-86, "Removal and Installation" .
Average vehicle speed (AVG) is not displayed.	Refer to AV-22, "Terminal and Reference Value for Audio Unit (Mid System)" or AV-25, "Terminal and Reference Value for Audio Unit (Premium System)" . If above is normal, replace display unit. Refer to AV-86, "Removal and Installation" .
Average fuel consumption (AVG) is not displayed.	Refer to AV-83, "Self-Diagnosis Mode" . If above is normal, replace display unit. Refer to AV-86, "Removal and Installation" .
Distance to empty (DTE) is not displayed.	<ul style="list-style-type: none"> Check if speedometer operates. If it does not operate, go to DI-17, "Vehicle Speed Signal Inspection". Check if fuel gauge operates. If it does not operate, go to DI-19, "Fuel Level Sensor Signal Inspection". Refer to AV-83, "Self-Diagnosis Mode". If above is normal, replace display unit. Refer to AV-86, "Removal and Installation" .
Door warning screen does not appear.	<ul style="list-style-type: none"> Refer to DI-17, "Vehicle Speed Signal Inspection". Refer to AV-83, "Self-Diagnosis Mode". If above is normal, replace display unit. Refer to AV-86, "Removal and Installation" .

Removal and Installation

INFOID:000000004409471

DISPLAY UNIT

To replace the display unit. Refer to [AV-51, "Removal and Installation"](#).

AV-86

INTEGRATED DISPLAY SYSTEM

< SERVICE INFORMATION >

STEERING WHEEL AUDIO CONTROL SWITCHES

To replace steering wheel audio control switches. Refer to [PS-7](#).

A

B

C

D

E

F

G

H

I

J

AV

L

M

N

O

P