

A  
B  
MT  
D  
E  
F  
G  
H  
I  
J  
K  
L  
M  
N  
O  
P

# SECTION **MT**

## MANUAL TRANSAXLE

### CONTENTS

<p style="text-align: center;"><b>RS6F94R</b></p> <p><b>SERVICE INFORMATION</b> ..... 3</p> <p><b>PRECAUTIONS</b> ..... 3</p> <p style="padding-left: 20px;">Precaution for Supplemental Restraint System (SRS) "AIR BAG" and "SEAT BELT PRE-TENSIONER" .....3</p> <p style="padding-left: 20px;">Precaution .....3</p> <p><b>PREPARATION</b> ..... 4</p> <p style="padding-left: 20px;">Special Service Tool .....4</p> <p style="padding-left: 20px;">Commercial Service Tool .....6</p> <p><b>NOISE, VIBRATION AND HARSHNESS (NVH) TROUBLESHOOTING</b> ..... 8</p> <p style="padding-left: 20px;">NVH Troubleshooting Chart .....8</p> <p><b>DESCRIPTION</b> ..... 9</p> <p style="padding-left: 20px;">Cross-Sectional View .....9</p> <p><b>M/T OIL</b> .....11</p> <p style="padding-left: 20px;">Changing M/T Oil ..... 11</p> <p style="padding-left: 20px;">Checking M/T Oil ..... 11</p> <p><b>SIDE OIL SEAL</b> .....12</p> <p style="padding-left: 20px;">Removal and Installation ..... 12</p> <p><b>POSITION SWITCH</b> .....13</p> <p style="padding-left: 20px;">Checking ..... 13</p> <p><b>CONTROL LINKAGE</b> .....14</p> <p style="padding-left: 20px;">Component of Control Device and Cable ..... 14</p> <p style="padding-left: 20px;">Removal and Installation ..... 14</p> <p><b>AIR BREATHER HOSE</b> .....16</p> <p style="padding-left: 20px;">Removal and Installation ..... 16</p> <p><b>TRANSAXLE ASSEMBLY</b> .....17</p> <p style="padding-left: 20px;">Component ..... 17</p> <p style="padding-left: 20px;">Removal and Installation ..... 17</p> <p style="padding-left: 20px;">Disassembly and Assembly ..... 18</p>	<p><b>INPUT SHAFT AND GEARS</b> .....36</p> <p style="padding-left: 20px;">Disassembly and Assembly .....36</p> <p><b>MAINSHAFT AND GEARS</b> .....40</p> <p style="padding-left: 20px;">Disassembly and Assembly .....40</p> <p><b>REVERSE IDLER SHAFT AND GEARS</b> .....45</p> <p style="padding-left: 20px;">Disassembly and Assembly .....45</p> <p><b>FINAL DRIVE</b> .....47</p> <p style="padding-left: 20px;">Disassembly and Assembly .....47</p> <p><b>SHIFT CONTROL</b> .....50</p> <p style="padding-left: 20px;">Inspection .....50</p> <p><b>SERVICE DATA AND SPECIFICATIONS (SDS)</b> .....51</p> <p style="padding-left: 20px;">General Specification .....51</p> <p style="text-align: center;"><b>RS6F52A</b></p> <p><b>SERVICE INFORMATION</b> .....52</p> <p><b>PRECAUTIONS</b> .....52</p> <p style="padding-left: 20px;">Precaution for Supplemental Restraint System (SRS) "AIR BAG" and "SEAT BELT PRE-TENSIONER" .....52</p> <p style="padding-left: 20px;">Service Notice or Precaution .....52</p> <p><b>PREPARATION</b> .....53</p> <p style="padding-left: 20px;">Special Service Tool .....53</p> <p style="padding-left: 20px;">Commercial Service Tool .....56</p> <p><b>NOISE, VIBRATION AND HARSHNESS (NVH) TROUBLESHOOTING</b> .....58</p> <p style="padding-left: 20px;">NVH Troubleshooting Chart .....58</p> <p><b>DESCRIPTION</b> .....59</p> <p style="padding-left: 20px;">Cross-Sectional View .....59</p> <p><b>M/T OIL</b> .....61</p> <p style="padding-left: 20px;">Changing M/T Oil .....61</p> <p style="padding-left: 20px;">Checking M/T Oil .....61</p>
---	---

<b>SIDE OIL SEAL</b> .....	<b>62</b>	<b>NOISE, VIBRATION AND HARSHNESS (NVH) TROUBLESHOOTING</b> .....	<b>134</b>
Removal and Installation .....	62	NVH Troubleshooting Chart .....	134
<b>POSITION SWITCH</b> .....	<b>63</b>	<b>DESCRIPTION</b> .....	<b>135</b>
Checking .....	63	Cross-Sectional View .....	135
<b>CONTROL LINKAGE</b> .....	<b>64</b>	<b>M/T OIL</b> .....	<b>137</b>
Component of Control Device and Cable .....	64	Changing M/T Oil .....	137
Removal and Installation .....	64	Checking M/T Oil .....	137
<b>AIR BREATHER HOSE</b> .....	<b>66</b>	<b>SIDE OIL SEAL</b> .....	<b>138</b>
Removal and Installation .....	66	Removal and Installation .....	138
<b>TRANSAXLE ASSEMBLY</b> .....	<b>67</b>	<b>POSITION SWITCH</b> .....	<b>139</b>
Component .....	67	Checking .....	139
Removal and Installation .....	67	<b>CONTROL LINKAGE</b> .....	<b>140</b>
Disassembly and Assembly .....	68	Component of Control Device and Cable .....	140
<b>INPUT SHAFT AND GEARS</b> .....	<b>98</b>	Removal and Installation .....	140
Disassembly and Assembly .....	98	<b>AIR BREATHER HOSE</b> .....	<b>142</b>
<b>MAINSHAFT AND GEARS</b> .....	<b>105</b>	Removal and Installation .....	142
Disassembly and Assembly .....	105	<b>TRANSAXLE ASSEMBLY</b> .....	<b>143</b>
<b>REVERSE IDLER SHAFT AND GEARS</b> .....	<b>113</b>	Component .....	143
Disassembly and Assembly .....	113	Removal and Installation .....	143
<b>FINAL DRIVE</b> .....	<b>115</b>	Disassembly and Assembly .....	144
Disassembly and Assembly .....	115	<b>INPUT SHAFT AND GEARS</b> .....	<b>174</b>
<b>SHIFT CONTROL</b> .....	<b>119</b>	Disassembly and Assembly .....	174
Disassembly and Assembly .....	119	<b>MAINSHAFT AND GEARS</b> .....	<b>181</b>
<b>SERVICE DATA AND SPECIFICATIONS (SDS)</b> .....	<b>122</b>	Disassembly and Assembly .....	181
General Specification .....	122	<b>REVERSE IDLER SHAFT AND GEARS</b> .....	<b>189</b>
Gear End Play .....	123	Disassembly and Assembly .....	189
Baulk Ring Clearance .....	123	<b>FINAL DRIVE</b> .....	<b>191</b>
Available Snap Rings .....	123	Disassembly and Assembly .....	191
Available C-Rings .....	124	<b>SHIFT CONTROL</b> .....	<b>193</b>
Available Thrust Washer .....	124	Disassembly and Assembly .....	193
Available Adjusting Shims .....	125	<b>SERVICE DATA AND SPECIFICATIONS (SDS)</b> .....	<b>196</b>
Available Shims .....	126	General Specification .....	196
<b>RS6F52H</b>			
<b>SERVICE INFORMATION</b> .....	<b>128</b>	Gear End Play .....	197
<b>PRECAUTIONS</b> .....	<b>128</b>	Baulk Ring Clearance .....	197
Precaution for Supplemental Restraint System (SRS) "AIR BAG" and "SEAT BELT PRE-TENSIONER" .....	128	Available Snap Rings .....	197
Service Notice or Precaution .....	128	Available C-Rings .....	198
<b>PREPARATION</b> .....	<b>129</b>	Available Thrust Washer .....	198
Special Service Tool .....	129	Available Adjusting Shims .....	199
Commercial Service Tool .....	132	Available Shims .....	200

# SERVICE INFORMATION

## PRECAUTIONS

### Precaution for Supplemental Restraint System (SRS) "AIR BAG" and "SEAT BELT PRE-TENSIONER"

INFOID:000000001850849

The Supplemental Restraint System such as "AIR BAG" and "SEAT BELT PRE-TENSIONER", used along with a front seat belt, helps to reduce the risk or severity of injury to the driver and front passenger for certain types of collision. This system includes seat belt switch inputs and dual stage front air bag modules. The SRS system uses the seat belt switches to determine the front air bag deployment, and may only deploy one front air bag, depending on the severity of a collision and whether the front occupants are belted or unbelted. Information necessary to service the system safely is included in the SRS and SB section of this Service Manual.

**WARNING:**

- To avoid rendering the SRS inoperative, which could increase the risk of personal injury or death in the event of a collision which would result in air bag inflation, all maintenance must be performed by an authorized NISSAN/INFINITI dealer.
- Improper maintenance, including incorrect removal and installation of the SRS, can lead to personal injury caused by unintentional activation of the system. For removal of Spiral Cable and Air Bag Module, see the SRS section.
- Do not use electrical test equipment on any circuit related to the SRS unless instructed to in this Service Manual. SRS wiring harnesses can be identified by yellow and/or orange harnesses or harness connectors.

### Precaution

INFOID:000000001850850

- If transaxle assembly is removed from the vehicle, always replace CSC (Concentric Slave Cylinder). Installed CSC returns to the original position when removing transaxle assembly. Dust on clutch disc sliding parts may damage CSC seal, and may cause clutch fluid leakage.
- Do not reuse transaxle oil.
- Drain, fill and check transaxle oil with the vehicle on level surface.
- During removal or installation, keep inside of transaxle clear of dust or dirt.
- Check for the correct installation orientation prior to removal or disassembly. If matching marks are required, be certain they do not interfere with the function of the parts they are applied to.
- In principle, tighten bolts or nuts gradually in several steps working diagonally from inside to outside. If tightening sequence is specified, follow it.
- Be careful not to damage the sliding surfaces and mating surfaces of parts.

A  
B  
MT  
D  
E  
F  
G  
H  
I  
J  
K  
L  
M  
N  
O  
P

# PREPARATION

< SERVICE INFORMATION >

[RS6F94R]

## PREPARATION

### Special Service Tool

INFOID:000000001850851

The actual shapes of Kent-Moore tools may differ from those of special service tools illustrated here.

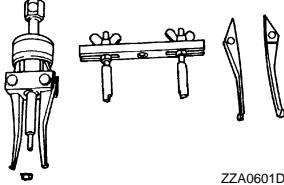
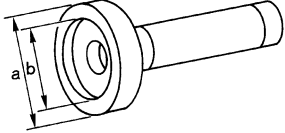
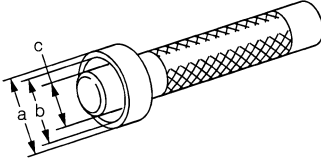
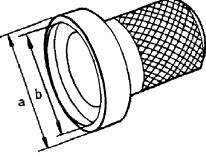
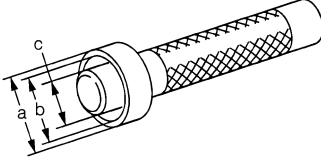
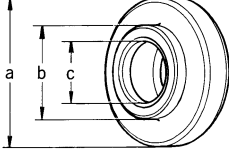
Tool number (Kent-Moore No.) Tool name	Description
KV381054S0 (J-34286) Puller   ZZA0601D	Removing mainshaft front bearing outer race
KV38100200 ( — ) Drift   ZZA1143D	<ul style="list-style-type: none"> <li>Installing mainshaft front bearing outer race</li> <li>Installing mainshaft rear bearing outer race</li> <li>Installing differential side bearing outer race (clutch housing side)</li> </ul> <b>a: 65 mm (2.56 in) dia.</b> <b>b: 49 mm (1.93 in) dia.</b>
ST33220000 ( — ) Drift   ZZA1046D	Installing input shaft oil seal <b>a: 37 mm (1.46 in) dia.</b> <b>b: 31 mm (1.22 in) dia.</b> <b>c: 22 mm (0.87 in) dia.</b>
ST33400001 (J-26082) Drift   ZZA0814D	Installing differential side bearing outer race (transaxle case side) <b>a: 60 mm (2.36 in) dia.</b> <b>b: 47 mm (1.85 in) dia.</b>
KV38100300 (J-25523) Drift   ZZA1046D	Installing differential side oil seal <b>a: 54 mm (2.13 in) dia.</b> <b>b: 46 mm (1.81 in) dia.</b> <b>c: 32 mm (1.26 in) dia.</b>
ST36720030 ( — ) Drift   ZZA0978D	<ul style="list-style-type: none"> <li>Installing input shaft rear bearing</li> <li>Installing mainshaft front bearing inner race</li> </ul> <b>a: 70 mm (2.76 in) dia.</b> <b>b: 40 mm (1.57 in) dia.</b> <b>c: 29 mm (1.14 in) dia.</b>

# PREPARATION

< SERVICE INFORMATION >

[RS6F94R]

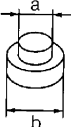
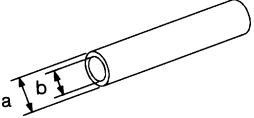
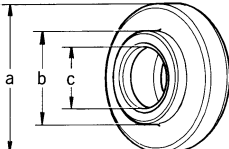
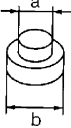
Tool number (Kent-Moore No.) Tool name	Description
ST33052000 (   —   ) Drift	 <p style="text-align: center; font-size: small;">ZZA0969D</p> <ul style="list-style-type: none"> <li>Removing mainshaft rear bearing inner race</li> <li>Removing 6th main gear</li> <li>Removing 5th main gear</li> <li>Removing 4th main gear</li> <li>Removing 1st-2nd synchronizer assembly</li> <li>Removing 2nd main gear</li> <li>Removing bushing</li> <li>Removing 3rd main gear</li> <li>Removing mainshaft front bearing inner race</li> </ul> <p><b>a: 22 mm (0.87 in) dia.</b>  <b>b: 28 mm (1.10 in) dia.</b></p>
KV32102700 (   —   ) Drift	 <p style="text-align: center; font-size: small;">S-NT065</p> <ul style="list-style-type: none"> <li>Installing bushing</li> <li>Installing 2nd main gear</li> <li>Installing 3rd main gear</li> <li>Installing 4th main gear</li> <li>Installing 5th main gear</li> <li>Installing 6th main gear</li> </ul> <p><b>a: 54 mm (2.13 in) dia.</b>  <b>b: 32 mm (1.26 in) dia.</b></p>
ST30901000 (J-26010-01) Drift	 <p style="text-align: center; font-size: small;">ZZA0978D</p> <p>Installing mainshaft rear bearing inner race</p> <p><b>a: 79 mm (3.11 in) dia.</b>  <b>b: 45 mm (1.77 in) dia.</b>  <b>c: 35.2 mm (1.386 in) dia.</b></p>
ST33061000 (J-8107-2) Drift	 <p style="text-align: center; font-size: small;">ZZA0969D</p> <p>Removing differential side bearing inner race (clutch housing side)</p> <p><b>a: 28.5 mm (1.122 in) dia.</b>  <b>b: 38 mm (1.50 in) dia.</b></p>

A  
B  
**MT**  
D  
E  
F  
G  
H  
I  
J  
K  
L  
M  
N  
O  
P

# PREPARATION

< SERVICE INFORMATION >

[RS6F94R]

## Commercial Service Tool

INFOID:000000001850852

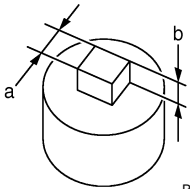
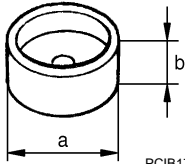
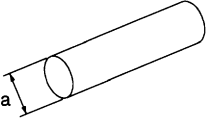
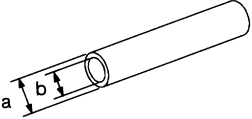
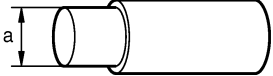
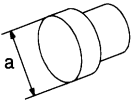
Tool name	Description
<p>Socket</p>  <p>PCIB1776E</p>	<p>Removing and installing drain plug  <b>a: 8 mm (0.31 in)</b>  <b>b: 5 mm (0.20 in)</b></p>
<p>Spacer</p>  <p>PCIB1780E</p>	<p>Removing mainshaft front bearing outer race  <b>a: 25 mm (0.98 in) dia.</b>  <b>b: 25 mm (0.98 in)</b></p>
<p>Drift</p>  <p>S-NT063</p>	<ul style="list-style-type: none"> <li>• Installing bushing</li> <li>• Installing shift lever oil seal</li> <li>• Installing select lever oil seal</li> </ul> <p><b>a: 17 mm (0.67 in) dia.</b></p>
<p>Drift</p>  <p>S-NT065</p>	<p>Installing input shaft front bearing  <b>a: 35 mm (1.38 in) dia.</b>  <b>b: 25 mm (0.98 in) dia.</b></p>
<p>Drift</p>  <p>PCIB1779E</p>	<p>Removing input shaft rear bearing  <b>a: 24 mm (0.94 in) dia.</b></p>
<p>Drift</p>  <p>NT109</p>	<ul style="list-style-type: none"> <li>• Removing differential side bearing inner race (transaxle case side)</li> <li>• Installing input shaft rear bearing</li> </ul> <p><b>a: 43 mm (1.69 in) dia.</b></p>

# PREPARATION

< SERVICE INFORMATION >

[RS6F94R]

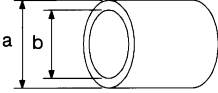
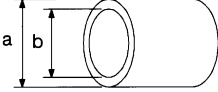
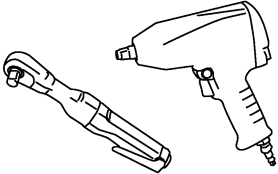
Tool name	Description
<p>Drift</p>  <p style="text-align: right;">S-NT474</p>	<p>Installing differential side bearing inner race (clutch housing side)</p> <p><b>a: 45 mm (1.77 in) dia.</b>  <b>b: 39 mm (1.54 in) dia.</b></p>
<p>Drift</p>  <p style="text-align: right;">S-NT474</p>	<p>Installing differential side bearing inner race (transaxle case side)</p> <p><b>a: 52 mm (2.05 in) dia.</b>  <b>b: 45 mm (1.77 in) dia.</b></p>
<p>Power tool</p>  <p style="text-align: right;">PBIC0190E</p>	<ul style="list-style-type: none"> <li>Loosening bolts and nuts</li> </ul>

A  
B  
MT  
D  
E  
F  
G  
H  
I  
J  
K  
L  
M  
N  
O  
P

# NOISE, VIBRATION AND HARSHNESS (NVH) TROUBLESHOOTING

< SERVICE INFORMATION >

[RS6F94R]

## NOISE, VIBRATION AND HARSHNESS (NVH) TROUBLESHOOTING

### NVH Troubleshooting Chart

INFOID:000000001850853

Use the chart below to help you find the cause of the symptom. The numbers indicate the order of the inspection. If necessary, repair or replace these parts.

Reference page		<a href="#">MT-11</a>		<a href="#">MT-18</a>		<a href="#">MT-18</a>	<a href="#">MT-14</a>	<a href="#">MT-18</a>	<a href="#">MT-18</a>				
SUSPECTED PARTS (Possible cause)		OIL (Oil level is low.)	OIL (Wrong oil.)	OIL (Oil level is high.)	GASKET (Damaged)	OIL SEAL (Worn or damaged)	O-RING (Worn or damaged)	SHIFT CONTROL LINKAGE (Worn)	SHIFT FORK (Worn)	GEAR (Worn or damaged)	BEARING (Worn or damaged)	BAULK RING (Worn or damaged)	INSERT SPRING (Damaged)
Symptoms	Noise	1	2							3	3		
	Oil leakage		3	1	2	2	2						
	Hard to shift or will not shift		1	1				2				3	3
	Jumps out of gear							1	2	2			



# DESCRIPTION

[RS6F94R]

< SERVICE INFORMATION >

## DESCRIPTION

### Cross-Sectional View

INFOID:000000001850854

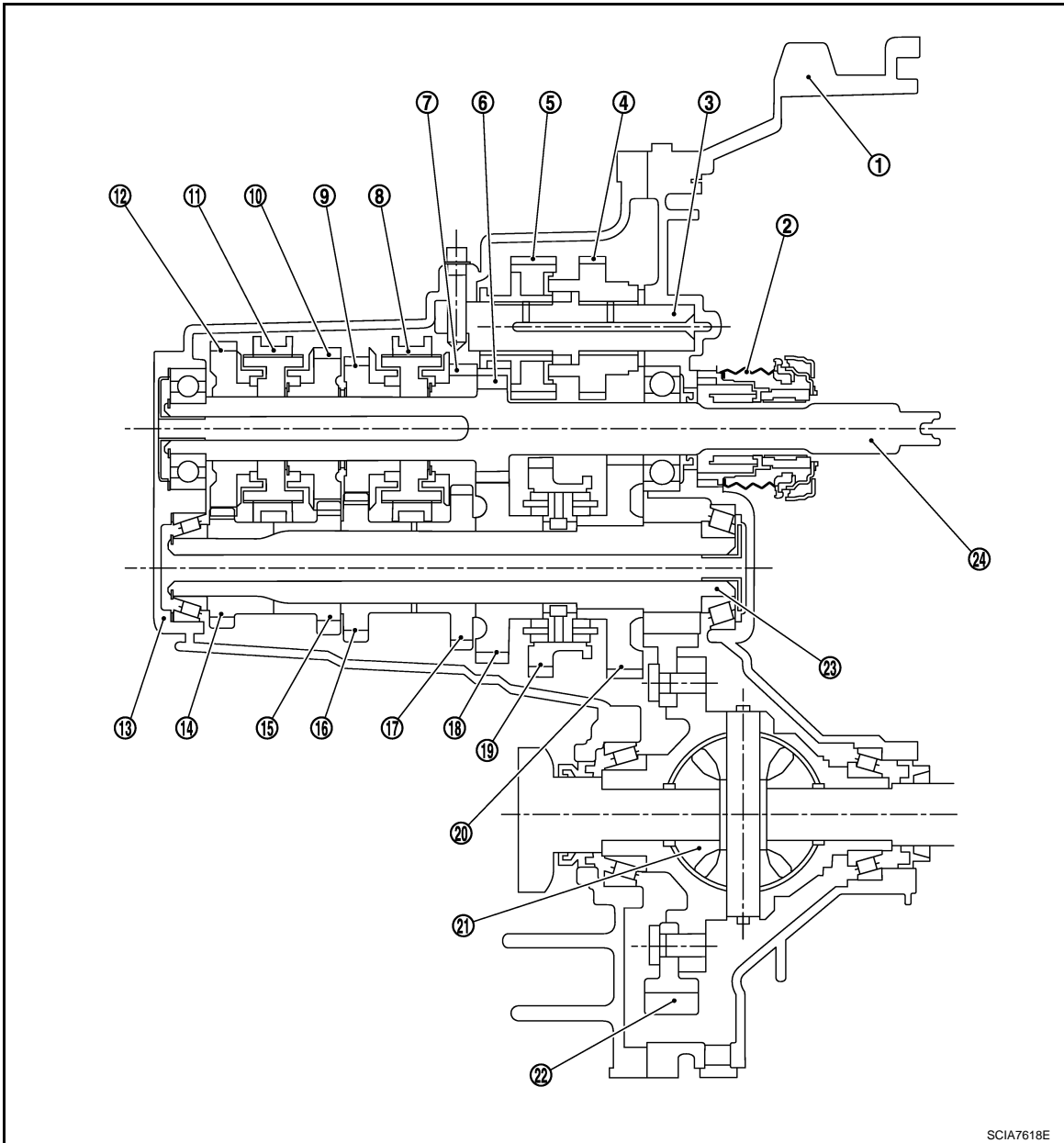

- |                                   |                                    |                           |
|-----------------------------------|------------------------------------|---------------------------|
| 1. Clutch housing                 | 2. CSC (Concentric Slave Cylinder) | 3. Reverse idler shaft    |
| 4. Reverse input gear             | 5. Reverse output gear             | 6. 2nd input gear         |
| 7. 3rd input gear                 | 8. 3rd-4th synchronizer assembly   | 9. 4th input gear         |
| 10. 5th input gear                | 11. 5th-6th synchronizer assembly  | 12. 6th input gear        |
| 13. Transaxle case                | 14. 6th main gear                  | 15. 5th main gear         |
| 16. 4th main gear                 | 17. 3rd main gear                  | 18. 2nd main gear         |
| 19. 1st-2nd synchronizer assembly | 20. 1st main gear                  | 21. Differential assembly |
| 22. Final gear                    | 23. Mainshaft                      | 24. Input shaft           |

### TRIPLE-CONE SYNCHRONIZER

A  
B  
MT  
D  
E  
F  
G  
H  
I  
J  
K  
L  
M  
N  
O  
P

## DESCRIPTION

[RS6F94R]

### < SERVICE INFORMATION >

Triple-cone synchronizer is used for the 1st and the 2nd gears to reduce operating force of the shift lever.

- 1st main gear (1)
- 1st-2nd coupling sleeve (2)
- Insert key (3)
- Outer baulk ring (4)
- 2nd main gear (5)
- Synchronizer cone (6)
- Inner baulk ring (7)
- 1st-2nd synchronizer hub (8)

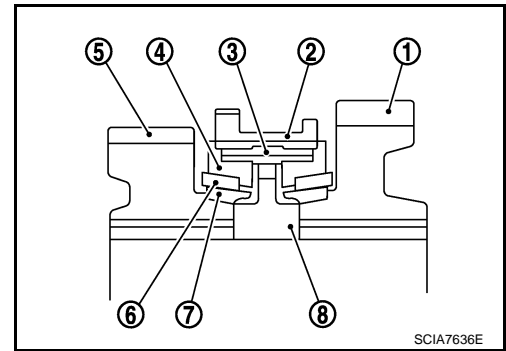

### REVERSE GEAR NOISE PREVENTION FUNCTION (SYNCHRONIZING METHOD)

Reverse gear assembly consists of reverse input gear, return spring, reverse baulk ring and reverse output gear. When the shift lever is shifted to the reverse position, the construction allows smooth shift operation by stopping the reverse idler shaft rotation by frictional force of synchronizer.

- Reverse fork rod (1)
- Reverse output gear (2)
- Return spring (3)
- Reverse baulk ring (4)
- Reverse input gear (5)

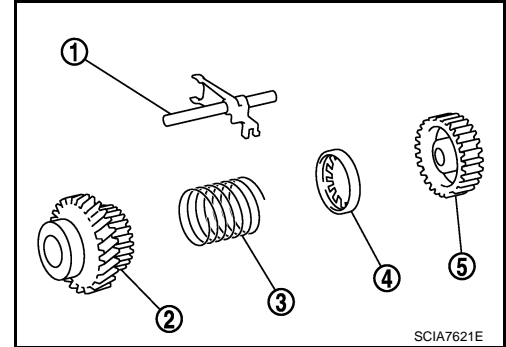

## M/T OIL

## Changing M/T Oil

INFOID:000000001850855

## DRAINING

1. Start engine and let it run to warm up transaxle.
2. Stop engine. Remove drain plug (1) and drain oil.
3. Install a new gasket onto drain plug (1) and install it into transaxle. Tighten drain plug to specification. Refer to [MT-18, "Disassembly and Assembly"](#).

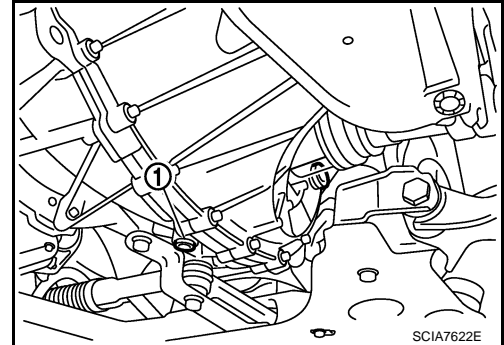
**CAUTION:****Do not reuse gasket.**

## FILLING

1. Remove filler plug (1). Fill with new oil until oil level reaches the specified limit at filler plug hole as shown.

**Oil grade and capacity** : Refer to [MA-13, "MR20DE"](#).

2. After refilling oil, check oil level. Install a new gasket on filler plug (1), then install it into transaxle. Tighten filler plug to specification. Refer to [MT-18, "Disassembly and Assembly"](#).

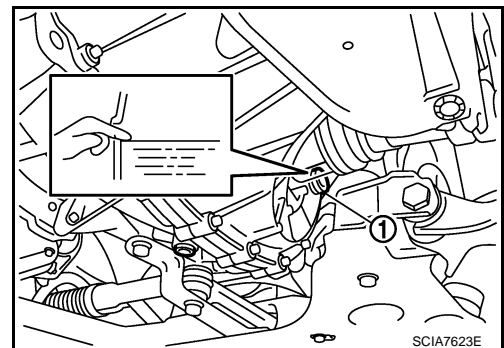
**CAUTION:****Do not reuse gasket.**

## Checking M/T Oil

INFOID:000000001850856

## OIL LEAKAGE AND OIL LEVEL

1. Make sure that oil is not leaking from transaxle or around it.
2. Remove filler plug (1) and check oil level at filler plug hole as shown.

**CAUTION:****Do not start engine while checking oil level.**

3. Install a new gasket onto filler plug (1) and install it into transaxle. Tighten filler plug to specification. Refer to [MT-18, "Disassembly and Assembly"](#).

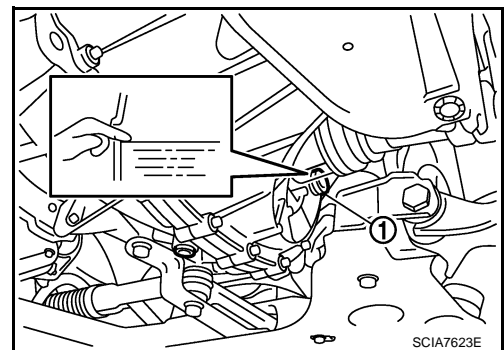
**CAUTION:****Do not reuse gasket.**

## SIDE OIL SEAL

### Removal and Installation

INFOID:000000001850857

#### REMOVAL

1. Remove front drive shafts from transaxle assembly. Refer to [FAX-8, "Removal and Installation \(Left Side\)"](#) and [FAX-10, "Removal and Installation \(Right Side\)"](#).

2. Remove differential side oil seal (1) using a suitable tool.

**CAUTION:**

**Be careful not to damage transaxle case and clutch housing.**

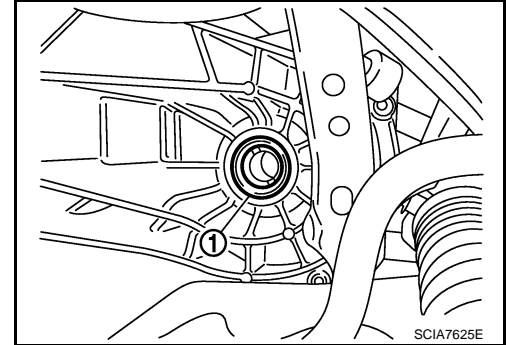

#### INSTALLATION

Installation is in the reverse order of removal.

- Install differential side oil seal (1) to clutch housing and transaxle case using Tool (A).

**Tool number A: ST38100300 (J-25523)**

**CAUTION:**

**Do not reuse oil seal.**

- Check oil level after installation. Refer to [MT-11, "Checking M/T Oil"](#).

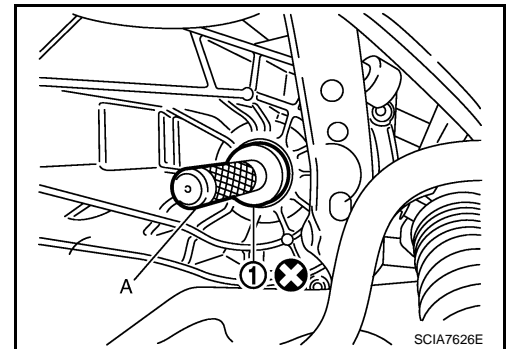

# POSITION SWITCH

[RS6F94R]

< SERVICE INFORMATION >

## POSITION SWITCH

### Checking

INFOID:000000001850858

#### NOTE:

For removal and installation of the switches, refer to [MT-18. "Disassembly and Assembly"](#).

#### BACK-UP LAMP SWITCH

- Check continuity between terminals 1 and 2.

Gear position	Continuity
Reverse	Yes
Except reverse	No

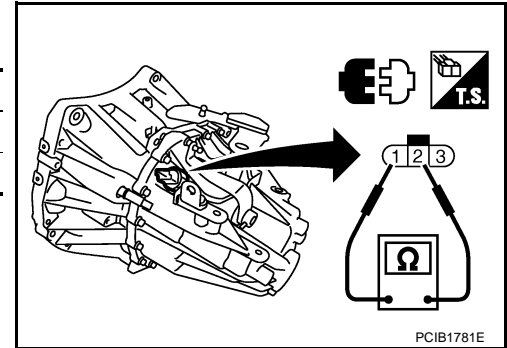

#### PARK/NEUTRAL POSITION SWITCH

- Check continuity between terminals 2 and 3.

Gear position	Continuity
Neutral	Yes
Except neutral	No

A  
B  
MT  
D  
E  
F  
G  
H  
I  
J  
K  
L  
M  
N  
O  
P

# CONTROL LINKAGE

< SERVICE INFORMATION >

[RS6F94R]

## CONTROL LINKAGE

### Component of Control Device and Cable

INFOID:000000001850859

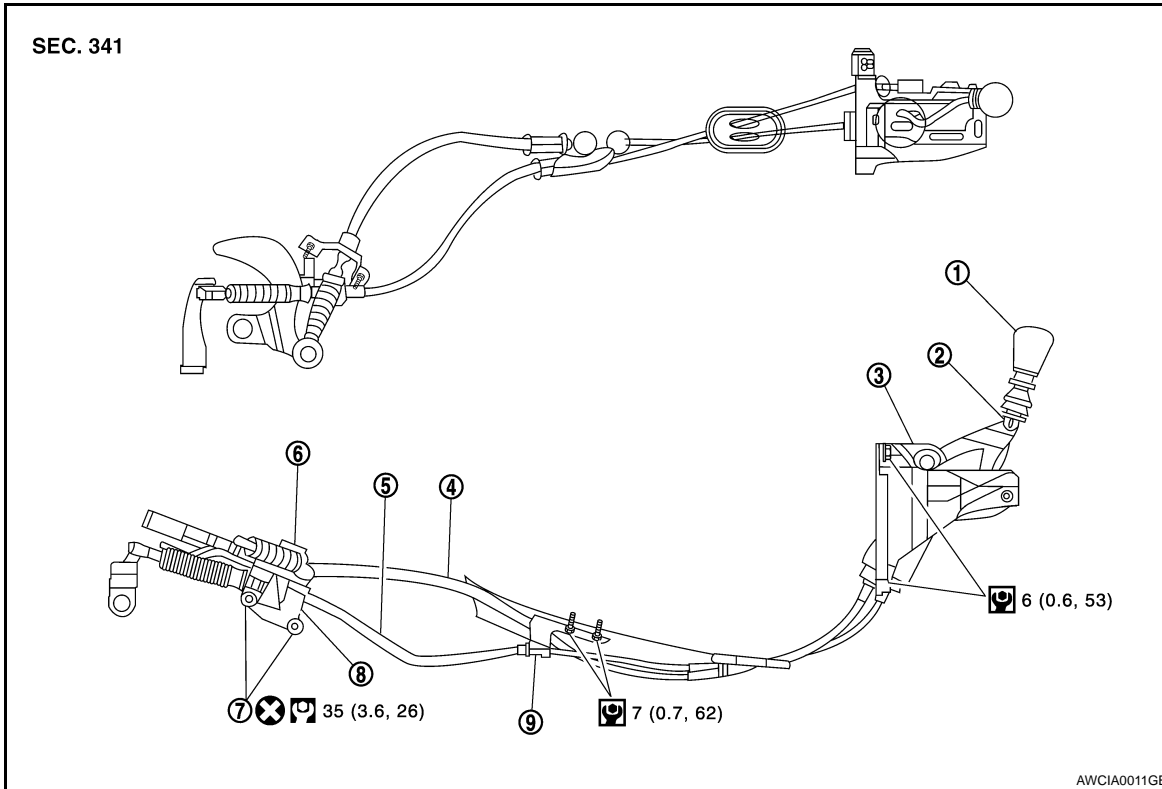

- |                       |                  |                            |
|-----------------------|------------------|----------------------------|
| 1. Control lever knob | 2. Control lever | 3. Control device assembly |
| 4. Select cable       | 5. Shift cable   | 6. Lock plate              |
| 7. Tapping bolt       | 8. Cable bracket | 9. Cable support bracket   |

### Removal and Installation

INFOID:000000001850860

#### REMOVAL

1. Remove battery. Refer to [SC-6, "Removal and Installation MR20DE"](#).
2. Remove air cleaner and air duct. Refer to [EM-16, "Removal and Installation"](#).
3. Remove shift cable from shift lever as shown.

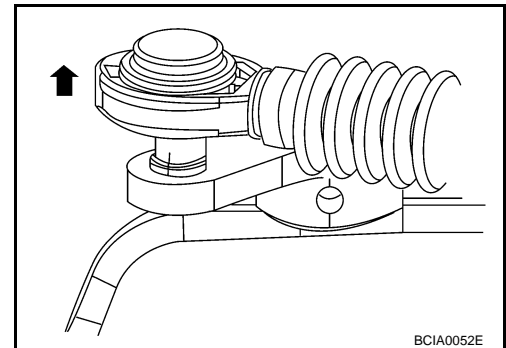

# CONTROL LINKAGE

[RS6F94R]

## < SERVICE INFORMATION >

4. Remove select cable from select lever as shown.

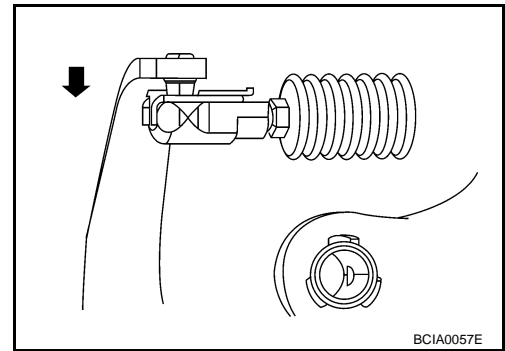

5. Shift control lever to neutral position.
6. Remove control lever knob.
7. Remove center console assembly. Refer to [IP-11, "Removal and Installation"](#).
8. Remove control device assembly nuts.
9. Remove exhaust front tube, center muffler and heat shield. Refer to [EX-3, "Removal and Installation"](#).
10. Remove cable support bracket.
11. Remove select cable and shift cable from cable bracket.
12. Remove control device assembly from the vehicle.

## INSTALLATION

Installation is in the reverse order of removal.

### NOTE:

Tapping work for tapping bolt is not applied to new clutch housing. Do not perform tapping by other than screwing tapping bolt because tapping is formed by screwing tapping bolt into clutch housing.

- Securely install each cable to shift lever and select lever.
- Be careful about the installation direction, and screw control lever knob onto control lever.

←: Front

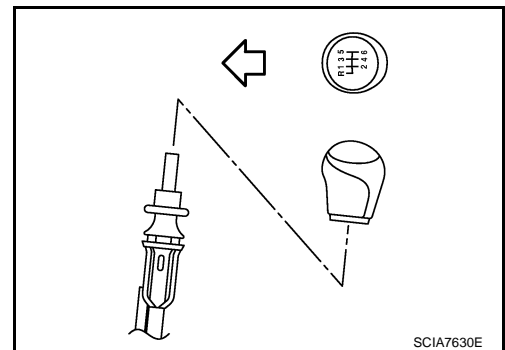

- When control lever is selected to 1st-2nd side and 5th-6th side, confirm control lever returns to neutral position smoothly.
- When control lever is shifted to each position, make sure there is no binding or disconnection in each boot.

# AIR BREATHER HOSE

[RS6F94R]

< SERVICE INFORMATION >

## AIR BREATHER HOSE

### Removal and Installation

INFOID:000000001850861

### COMPONENTS

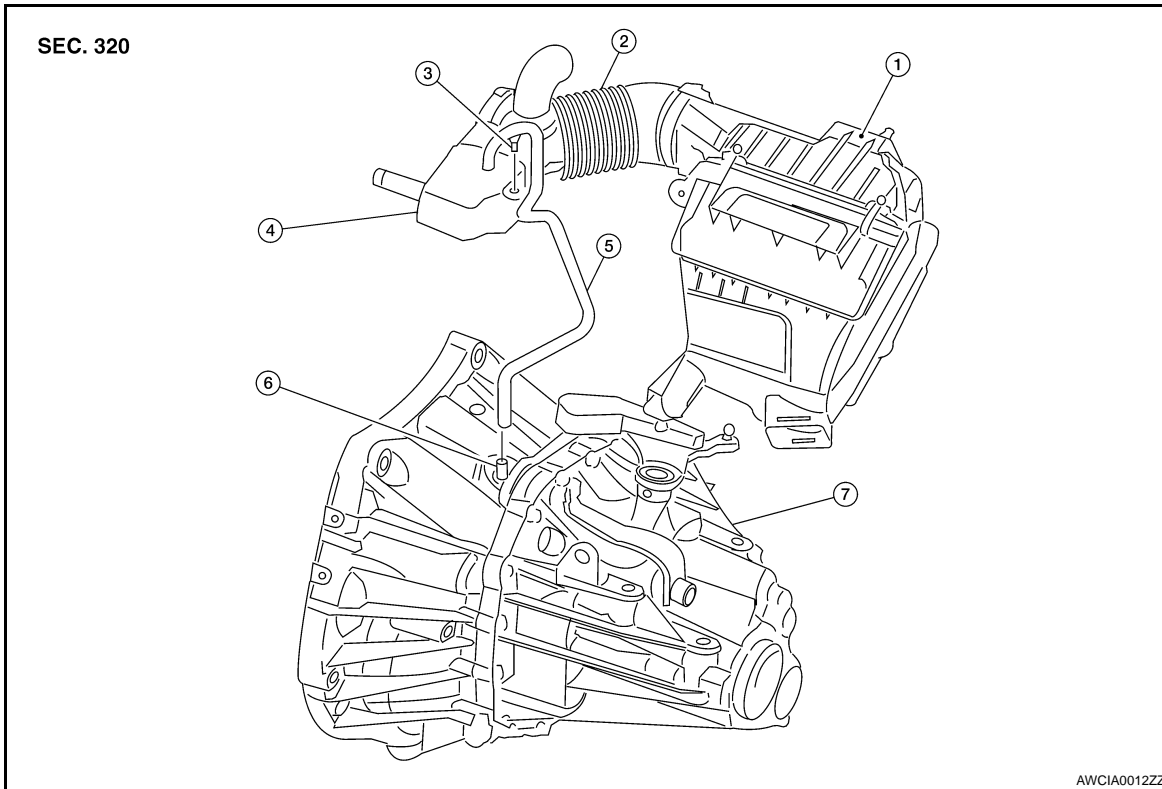

- |                       |                      |                      |
|-----------------------|----------------------|----------------------|
| 1. Air cleaner case   | 2. Air duct          | 3. Clip              |
| 4. Resonator          | 5. Air breather hose | 6. Two way connector |
| 7. Transaxle assembly |                      |                      |

### REMOVAL

1. Disconnect air breather hose clips and disconnect air breather hose from resonator.
2. Remove air breather hose.

**CAUTION:**

**When removing air breather hose, be sure to hold two way connector securely.**

### INSTALLATION

Installation is in the reverse order of removal.

- When installing air breather hose on two way connector, aim paint mark face toward the vehicle front.
- When installing air breather hose on two way connector, push it until it hits transaxle case.
- When installing air breather hose to resonator, make sure that clips are fully inserted.

**CAUTION:**

**Make sure air breather hose is not collapsed or blocked due to folding or bending when installed.**



# TRANSAXLE ASSEMBLY

< SERVICE INFORMATION >

[RS6F94R]

## TRANSAXLE ASSEMBLY

### Component

INFOID:000000001850862

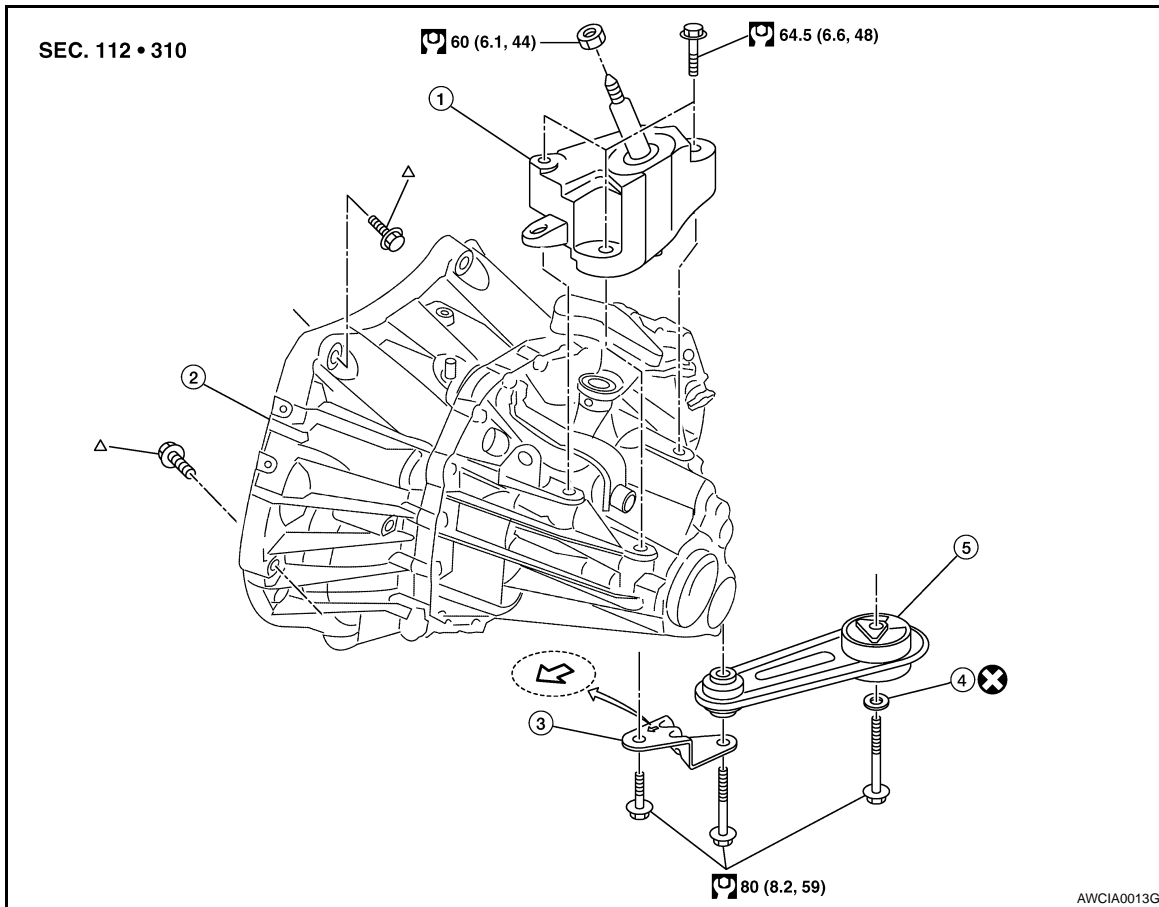

- |   |                       |                              |
|---|-----------------------|------------------------------|
| 1. LH engine mount bracket (transaxle side) | 2. Transaxle assembly | 3. Rear engine mount bracket |
| 4. Washer                                   | 5. Rear torque rod    | ⇐: Front                     |

Δ: Refer to [MT-17, "Removal and Installation"](#).

### Removal and Installation

INFOID:000000001850863

#### CAUTION:

If transaxle assembly is removed from the vehicle, always replace CSC (Concentric Slave Cylinder). Inserted CSC returns to the original position when removing transaxle assembly. Dust on clutch disc sliding parts may damage CSC seal, and may cause clutch fluid leakage.

#### REMOVAL

1. Drain gear oil. Refer to [MT-11, "Changing M/T Oil"](#).
2. Drain clutch fluid and remove clutch tube from CSC. Refer to [CL-12, "Removal and Installation"](#).

#### CAUTION:

**Do not depress clutch pedal during removal procedure.**

3. Remove engine and transaxle assembly. Refer to [EM-99, "Removal and Installation"](#).
4. Remove starter motor. Refer to [SC-21, "Removal and Installation MR20DE"](#).
5. Remove transaxle assembly to engine bolts.
6. Separate transaxle assembly from engine.

#### INSTALLATION

Installation is in the reverse order of removal.

- If transaxle is removed from the vehicle, always replace CSC. Refer to [CL-11, "Removal and Installation"](#).

# TRANSAXLE ASSEMBLY

[RS6F94R]

## < SERVICE INFORMATION >

- When installing the transaxle assembly to the engine, install the bolts as shown.

**CAUTION:**

**When installing transaxle assembly, be careful not to bring transaxle input shaft into contact with clutch cover.**

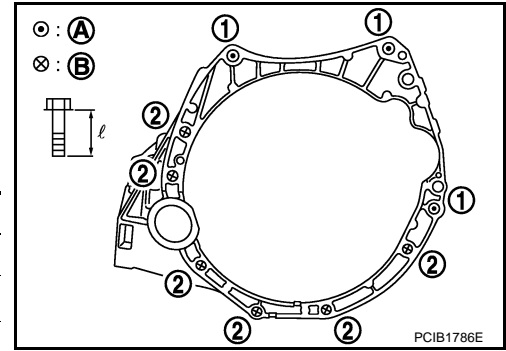

Bolt No.	1	2
Quantity	3	6
Bolt length "ℓ" mm (in)	60 (2.36)	50 (1.97)
Tightening torque N·m (kg·m, ft·lb)	62.0 (6.3, 46)	

A: M/T to engine

B: Engine to M/T

- Bleed the air from the clutch hydraulic system. Refer to [CL-8, "Air Bleeding Procedure"](#).
- After installation, check oil level, and check for leaks and loose mechanisms. Refer to [MT-11, "Checking M/T Oil"](#).

## Disassembly and Assembly

INFOID:000000001850864

## COMPONENTS

Case and Housing Components

# TRANSAXLE ASSEMBLY

< SERVICE INFORMATION >

[RS6F94R]

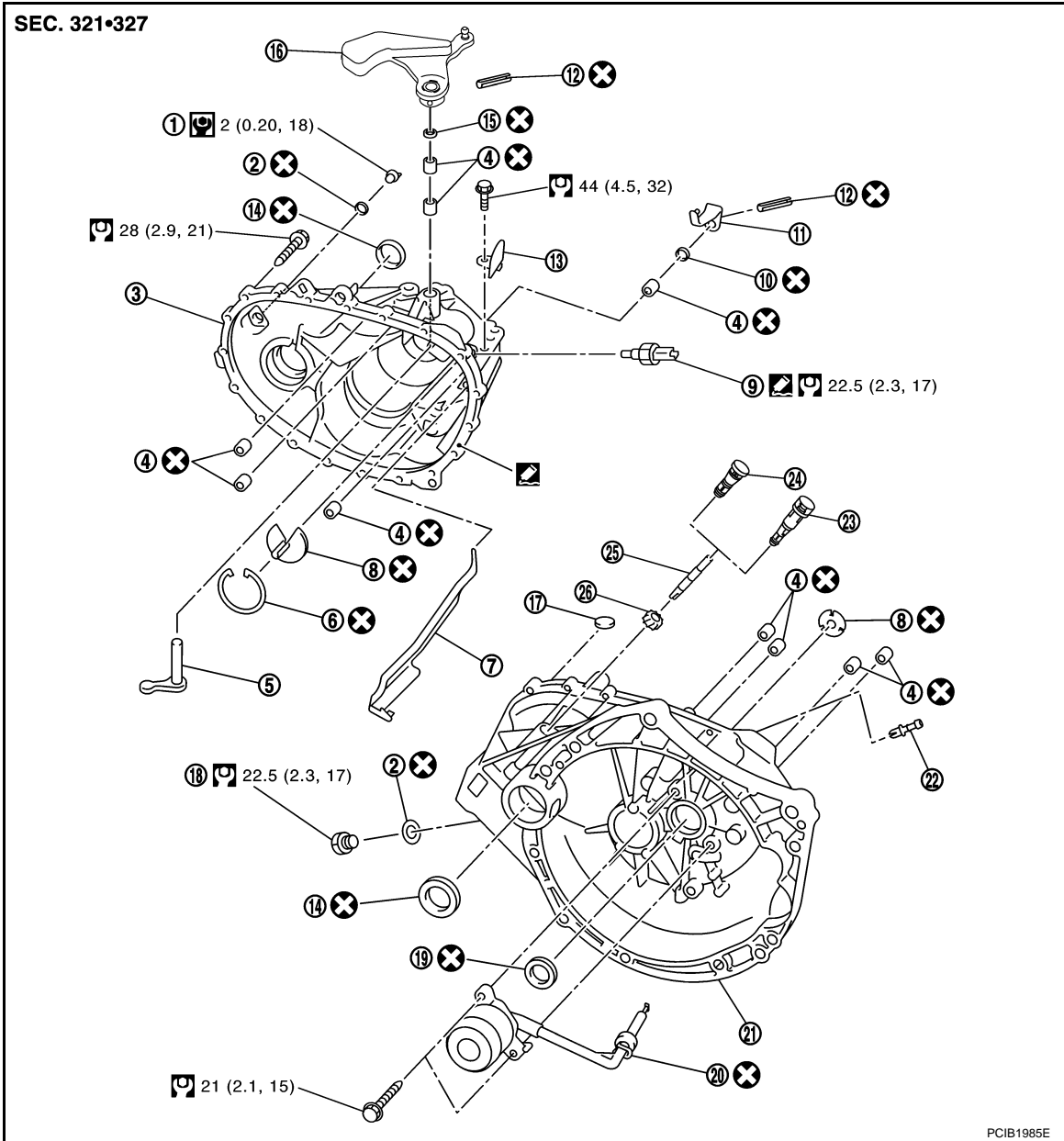

- |                          |                                       |                            |
|--------------------------|---------------------------------------|----------------------------|
| 1. Filler plug           | 2. Gasket                             | 3. Transaxle case          |
| 4. Bushing               | 5. Shift finger                       | 6. Snap ring               |
| 7. Oil gutter            | 8. Oil channel                        | 9. Position switch         |
| 10. Shift lever oil seal | 11. Shift lever                       | 12. Retaining pin          |
| 13. Bracket              | 14. Differential side oil seal        | 15. Select lever oil seal  |
| 16. Select lever         | 17. Magnet                            | 18. Drain plug             |
| 19. Input shaft oil seal | 20. CSC (Concentric Slave Cylinder)   | 21. Clutch housing         |
| 22. Two way connector    | 23. Speed sensor (Without ABS models) | 24. Plug (With ABS models) |
| 25. Pinion shaft         | 26. Pinion gear                       |                            |

 Apply Genuine Silicone RTV or the equivalent. Refer to [GI-42, "Recommended Chemical Product and Sealant"](#).

Gear Components

A  
B  
MT  
D  
E  
F  
G  
H  
I  
J  
K  
L  
M  
N  
O  
P

# TRANSAXLE ASSEMBLY

< SERVICE INFORMATION >

[RS6F94R]

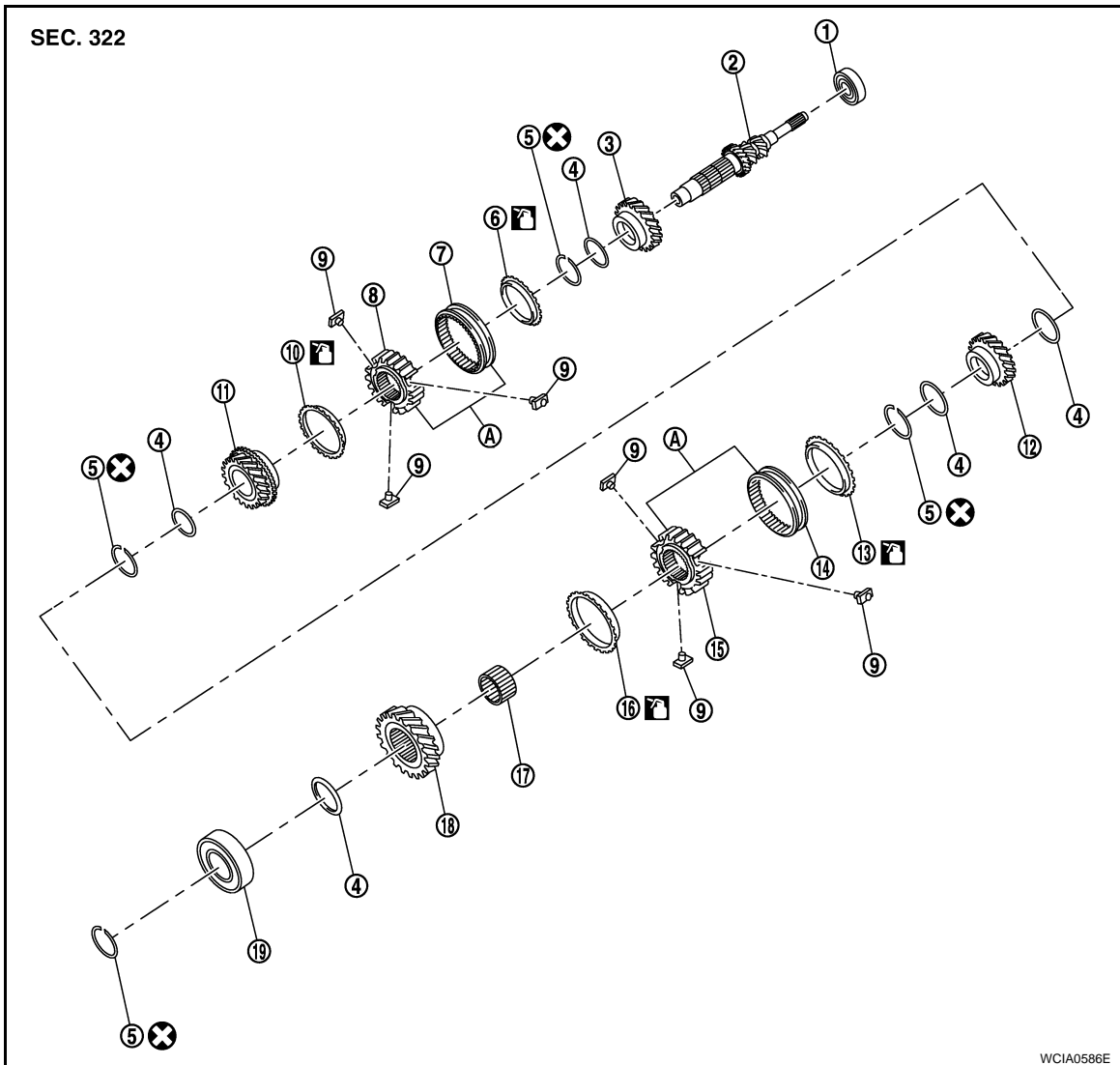

- |                              |                               |                              |
|------------------------------|-------------------------------|------------------------------|
| 1. Input shaft front bearing | 2. Input shaft                | 3. 3rd input gear            |
| 4. Washer                    | 5. Snap ring                  | 6. 3rd baulk ring            |
| 7. 3rd-4th coupling sleeve   | 8. 3rd-4th synchronizer hub   | 9. Insert key                |
| 10. 4th baulk ring           | 11. 4th input gear            | 12. 5th input gear           |
| 13. 5th baulk ring           | 14. 5th-6th coupling sleeve   | 15. 5th-6th synchronizer hub |
| 16. 6th baulk ring           | 17. Needle bearing            | 18. 6th input gear           |
| 19. Input shaft rear bearing | A. Replace the parts as a set | Apply gear oil               |

# TRANSAXLE ASSEMBLY

< SERVICE INFORMATION >

[RS6F94R]

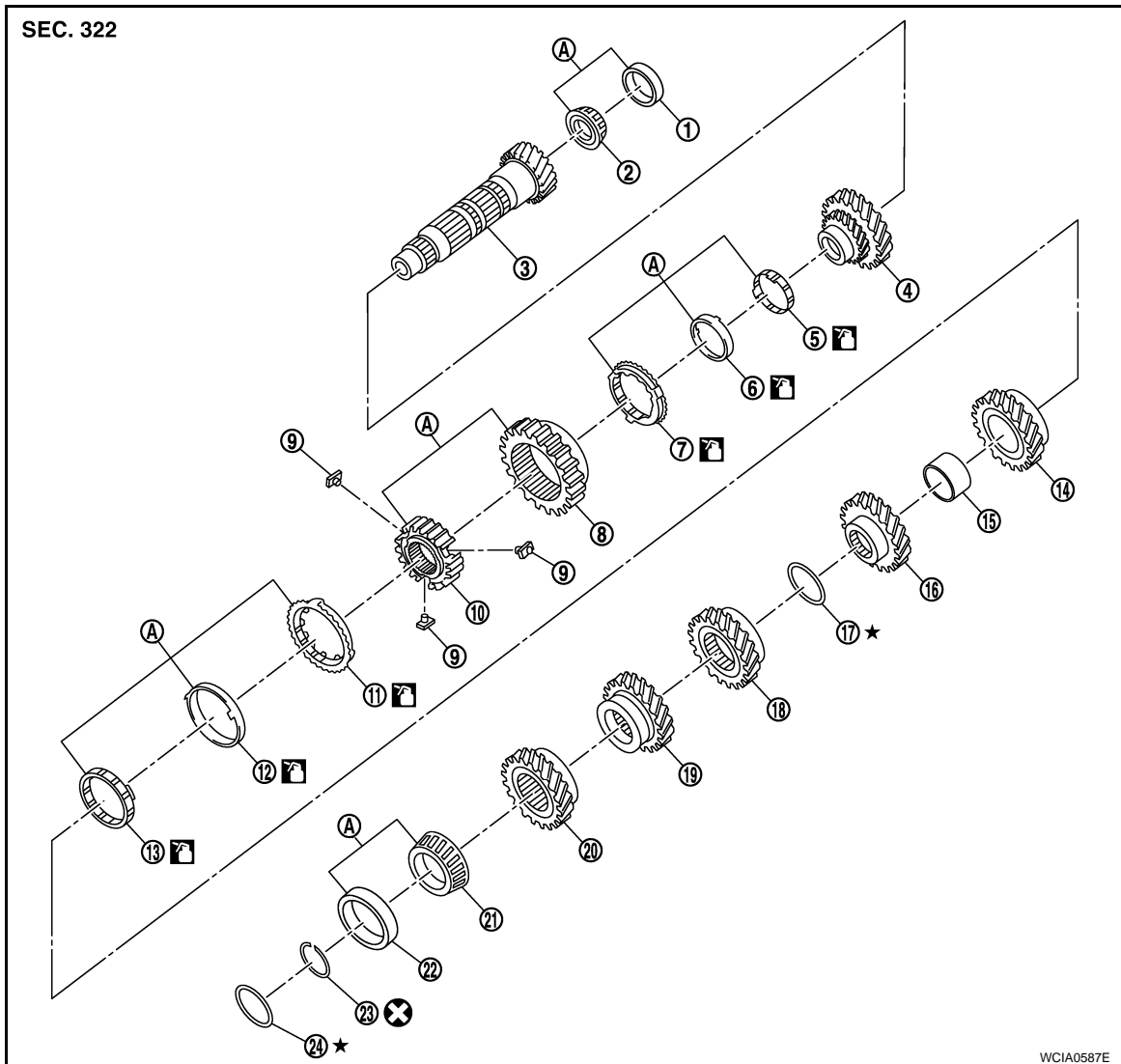

- |                                       |                                       |                                       |
|---------------------------------------|---------------------------------------|---------------------------------------|
| 1. Mainshaft front bearing outer race | 2. Mainshaft front bearing inner race | 3. Mainshaft                          |
| 4. 1st main gear                      | 5. 1st inner baulk ring               | 6. 1st synchronizer cone              |
| 7. 1st outer baulk ring               | 8. 1st-2nd coupling sleeve            | 9. Insert key                         |
| 10. 1st-2nd synchronizer hub          | 11. 2nd outer baulk ring              | 12. 2nd synchronizer cone             |
| 13. 2nd inner baulk ring              | 14. 2nd main gear                     | 15. Bushing                           |
| 16. 3rd main gear                     | 17. Intermediate adjusting shim       | 18. 4th main gear                     |
| 19. 5th main gear                     | 20. 6th main gear                     | 21. Mainshaft rear bearing inner race |
| 22. Mainshaft rear bearing outer race | 23. Snap ring                         | 24. Bearing preloading shim           |
| A. Replace the parts as a set         | Apply gear oil                        |                                       |

A

B

MT

D

E

F

G

H

I

J

K

L

M

N

O

P

# TRANSAXLE ASSEMBLY

< SERVICE INFORMATION >

[RS6F94R]

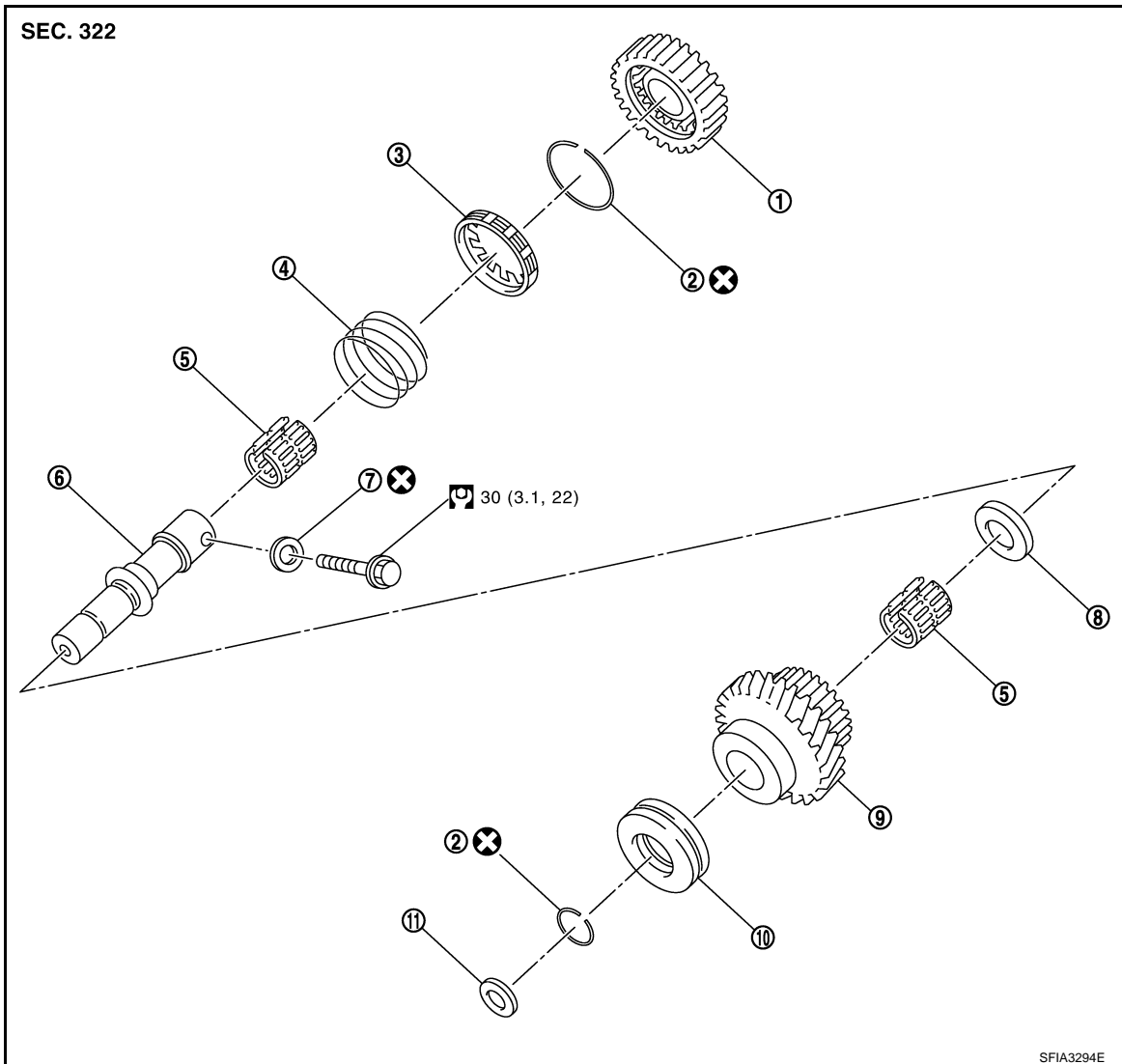

- |                        |                   |                        |
|------------------------|-------------------|------------------------|
| 1. Reverse output gear | 2. Snap ring      | 3. Reverse bulk ring   |
| 4. Return spring       | 5. Needle bearing | 6. Reverse idler shaft |
| 7. Seal washer         | 8. Washer         | 9. Reverse input gear  |
| 10. Lock washer        | 11. Spring washer |                        |

Shift Control Components

# TRANSAXLE ASSEMBLY

< SERVICE INFORMATION >

[RS6F94R]

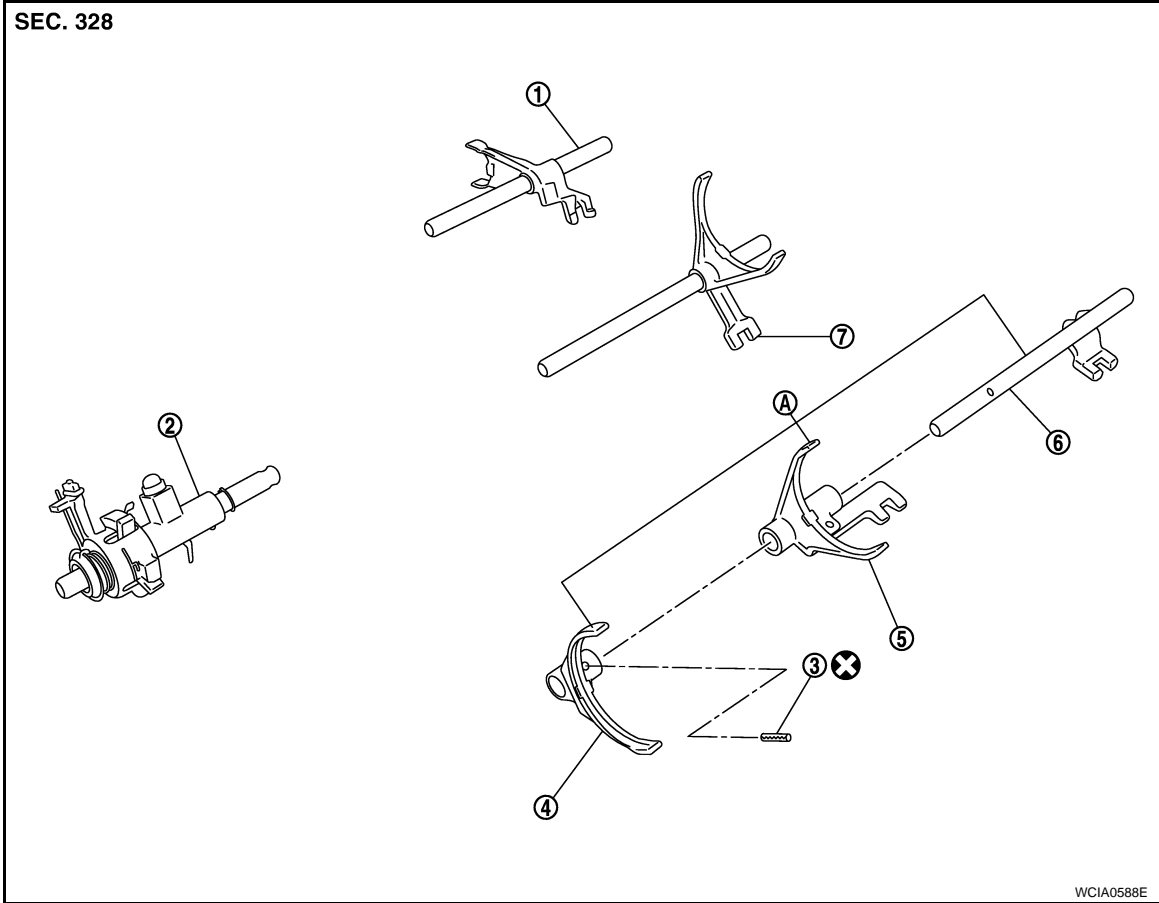

- |                       |                               |                                 |
|-----------------------|-------------------------------|---------------------------------|
| 1. Reverse fork rod   | 2. Selector                   | 3. Retaining pin                |
| 4. 5th-6th shift fork | 5. 3rd-4th shift fork         | 6. 3rd-4th and 5th-6th fork rod |
| 7. 1st-2nd fork rod   | A. Replace the parts as a set |                                 |

Final Drive Components

A  
B  
MT  
D  
E  
F  
G  
H  
I  
J  
K  
L  
M  
N  
O  
P

# TRANSAXLE ASSEMBLY

< SERVICE INFORMATION >

[RS6F94R]

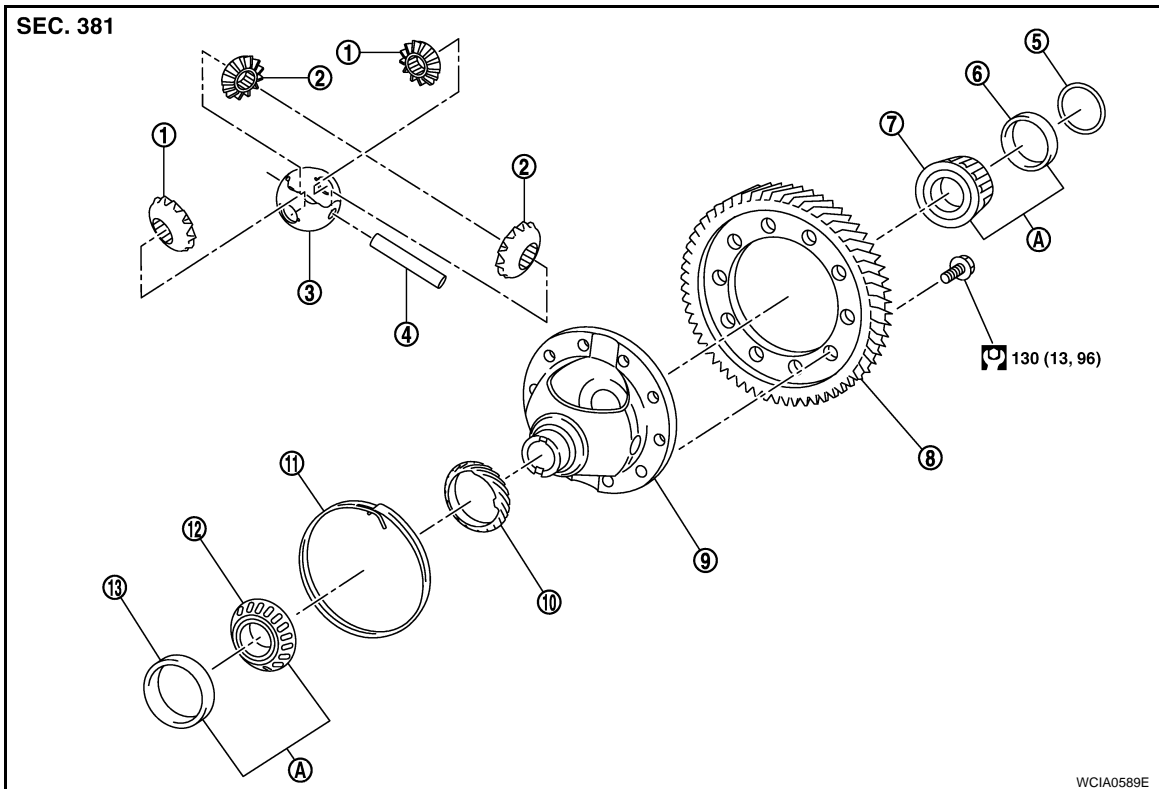

- |  |                               |  |
|--|-------------------------------|--|
| 1. Side gear   | 2. Pinion mate gear           | 3. Thrust washer   |
| 4. Pinion mate shaft   | 5. shim                       | 6. Differential side bearing outer race (transaxle case side)  |
| 7. Differential side bearing inner race (transaxle case side)  | 8. Final gear                 | 9. Differential case   |
| 10. Speedometer drive gear                                     | 11. Lock ring                 | 12. Differential side bearing inner race (clutch housing side) |
| 13. Differential side bearing outer race (clutch housing side) | A. Replace the parts as a set |  |

## DISASSEMBLY

1. Remove drain plug and gasket from clutch housing using the socket, and drain oil.
2. Remove filler plug and gasket from transaxle case.
3. Remove CSC from clutch housing.
4. Remove retaining pin from shift lever (1) using a suitable tool.
5. Remove shift lever (1).
6. Remove bracket (2) and position switch (3) from transaxle case.

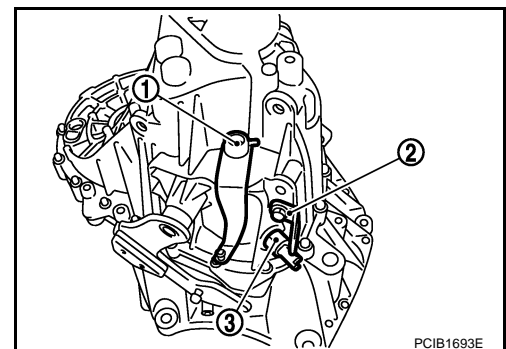



# TRANSAXLE ASSEMBLY

[RS6F94R]

## < SERVICE INFORMATION >

7. Remove bolts.

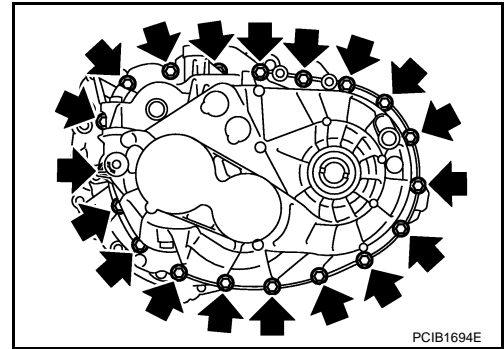

8. Remove reverse idler shaft bolt (←) and seal washer.

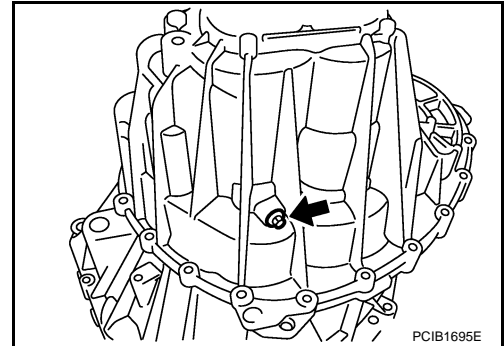

9. Remove transaxle case (1) upward while rotating select lever (2).

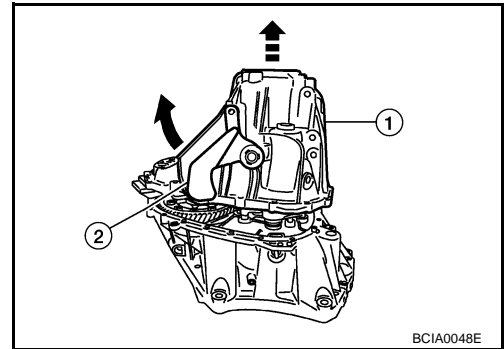

10. Remove spring (1) of selector from return bushing (2).

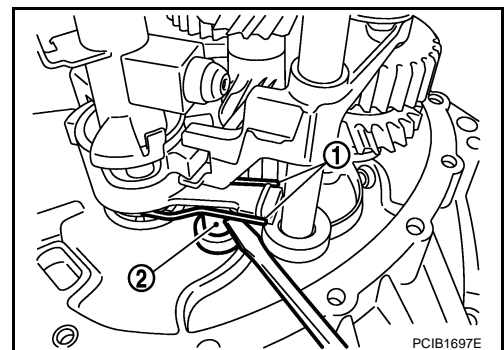

11. Move 1st-2nd fork rod (1), 3rd-4th and 5th-6th fork rod (2), and reverse fork rod (3) to neutral position.

12. Remove selector (4) from clutch housing.

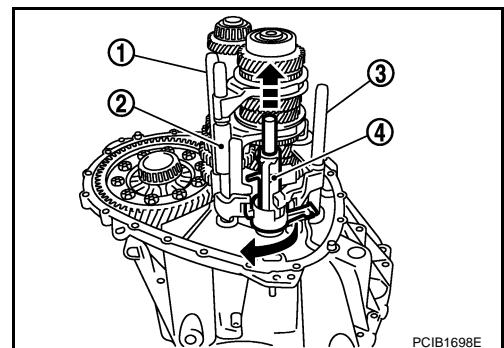

A

B

MT

D

E

F

G

H

I

J

K

L

M

N

O

P

# TRANSAXLE ASSEMBLY

[RS6F94R]

< SERVICE INFORMATION >

13. Remove retaining pin from 5th-6th shift fork using a suitable tool.

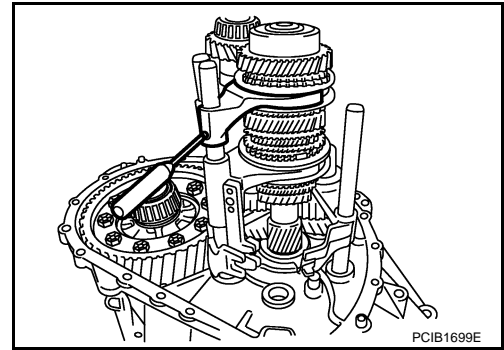

14. Remove 3rd-4th and 5th-6th fork rod assembly according to the following.

- a. Lift the fork rod (1) up.
- b. Remove 3rd-4th and 5th-6th fork rod assembly from clutch housing.

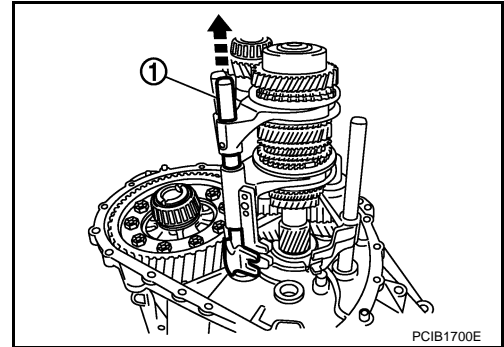

15. Remove reverse gear assembly (1) according to the following.

- a. Lift the input shaft assembly (2) and mainshaft assembly (3) up.
  - b. Remove reverse gear assembly (1) and reverse fork rod (4) from clutch housing.
16. Remove spring washer located under the reverse idler shaft.

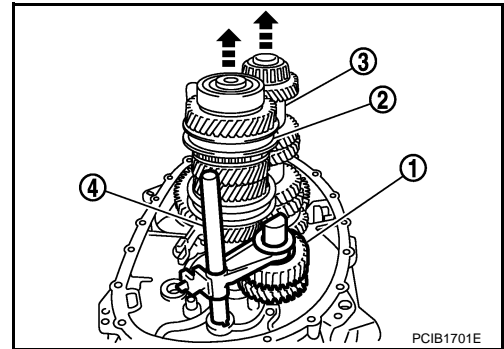

17. Remove input shaft assembly (1), mainshaft assembly (2), and 1st-2nd fork rod (3) from clutch housing.

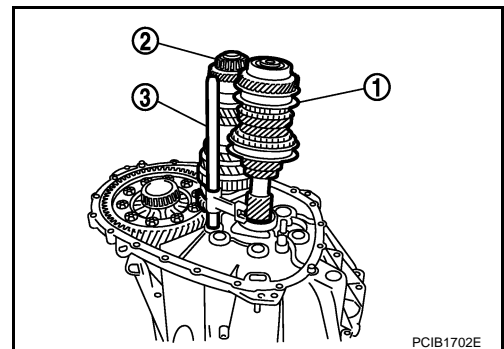

18. Remove final drive assembly (1) from clutch housing.

19. Remove magnet from clutch housing.

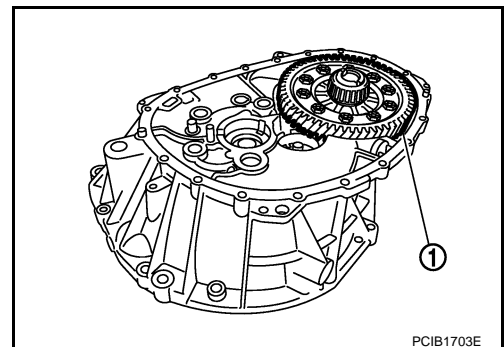

# TRANSAXLE ASSEMBLY

[RS6F94R]

< SERVICE INFORMATION >

20. Remove differential side oil seals (1) from clutch housing and transaxle case using a suitable tool.

**CAUTION:**

**Be careful not to damage clutch housing and transaxle case.**

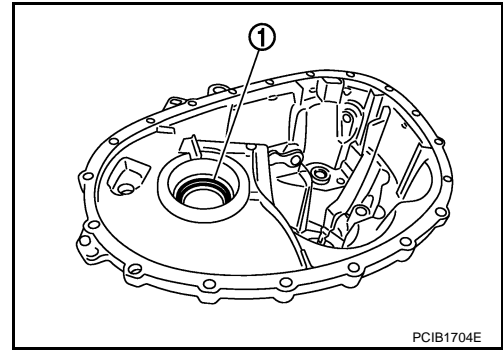

21. Remove differential side bearing outer race (1) from clutch housing using a suitable tool.

**CAUTION:**

**Be careful not to damage clutch housing.**

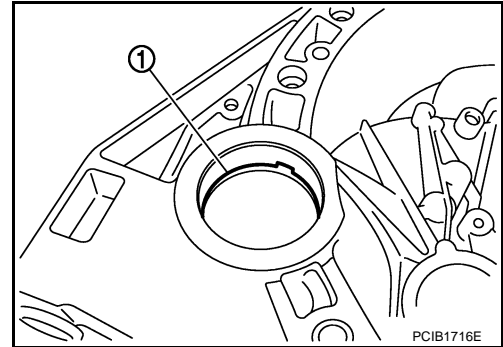

22. Remove differential side bearing outer race (1) and shim (2) from transaxle case using a brass bar as shown.

**CAUTION:**

**Be careful not to damage transaxle case.**

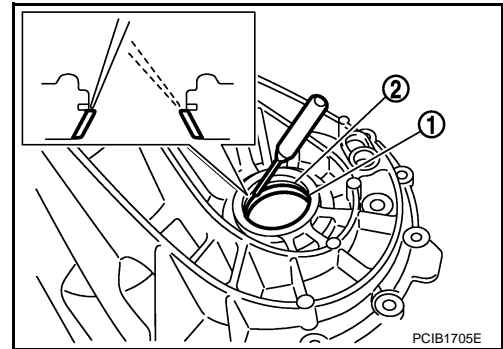

23. Remove retaining pin from select lever (1) using a suitable tool.

24. Remove select lever.

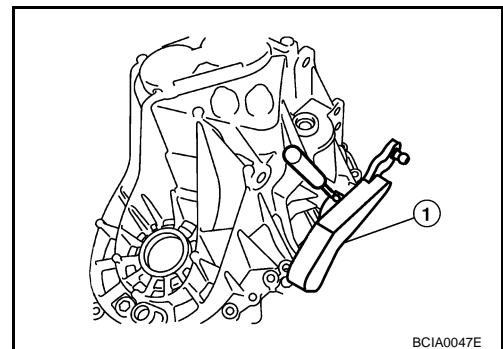

25. Remove shift finger (1) from transaxle case.

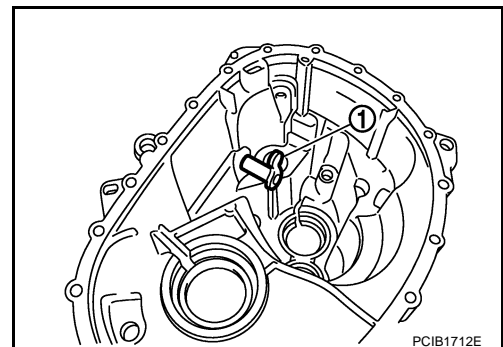

A

B

MT

D

E

F

G

H

I

J

K

L

M

N

O

P

# TRANSAXLE ASSEMBLY

[RS6F94R]

## < SERVICE INFORMATION >

26. Remove select lever oil seal and bushings from transaxle case using a suitable tool.

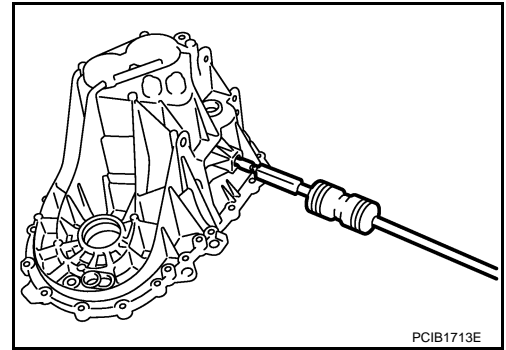

27. Remove oil gutter (1) from transaxle case.

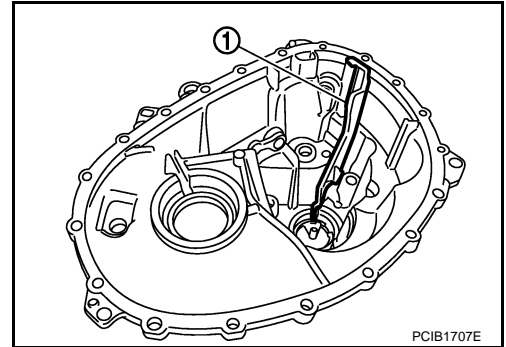

28. Remove shift lever oil seal (1) from transaxle case.

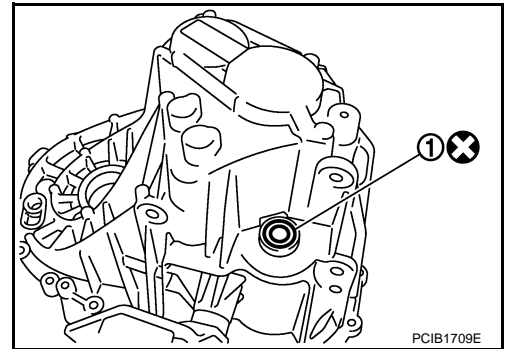

29. Remove bushings (1) from transaxle case using a suitable tool.

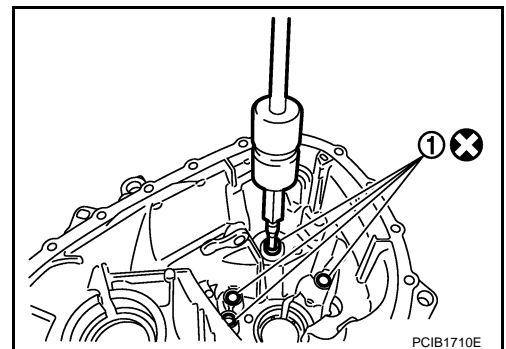

30. Remove mainshaft rear bearing outer race and bearing preloading shim from transaxle case using a suitable tool.

**CAUTION:**

**Be careful not to damage transaxle case.**

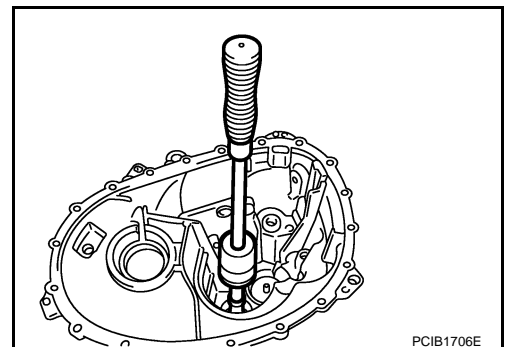

# TRANSAXLE ASSEMBLY

[RS6F94R]

< SERVICE INFORMATION >

31. Remove snap ring (1) and oil channel (2) from transaxle case.

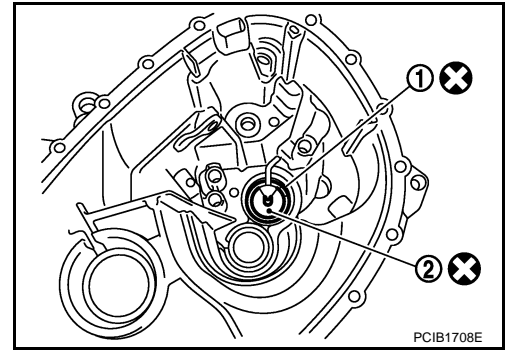

32. Remove input shaft oil seal (1) from clutch housing using a suitable tool.

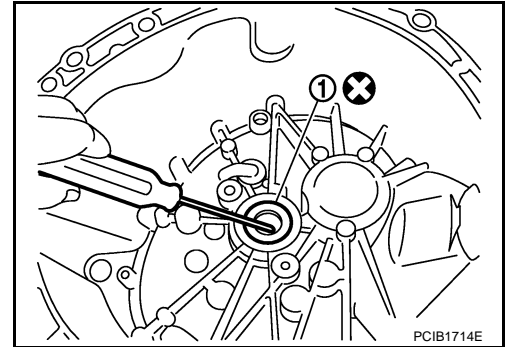

33. Remove mainshaft front bearing outer race (1) and oil channel (2) from clutch housing using Tool (A) and suitable tool (B).

**Tool number**    **A: KV381054S0 (J-34286)**

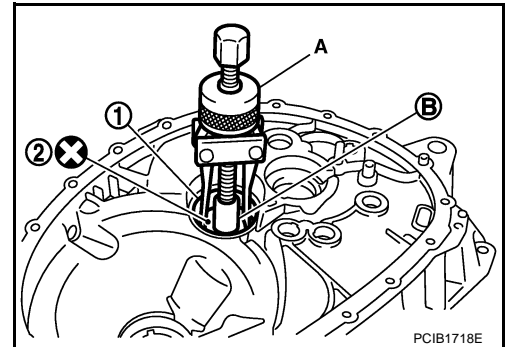

34. Remove busings (1) from clutch housing using a suitable tool.

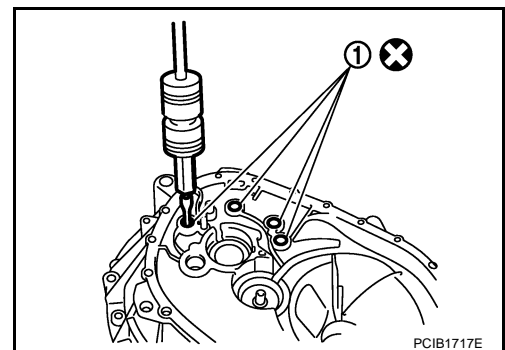

35. Remove two way connector (1) from clutch housing.

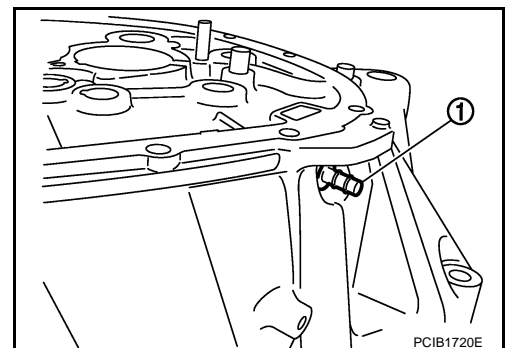

A  
B  
MT  
D  
E  
F  
G  
H  
I  
J  
K  
L  
M  
N  
O  
P

# TRANSAXLE ASSEMBLY

< SERVICE INFORMATION >

[RS6F94R]

36. Remove pinion gear (1) and pinion shaft (2) from clutch housing.

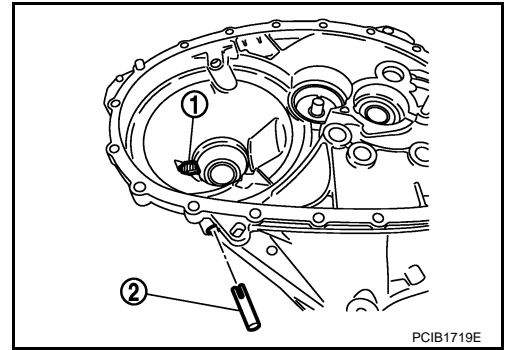

## ASSEMBLY

1. Install pinion gear (1) and pinion shaft (2) into clutch housing.

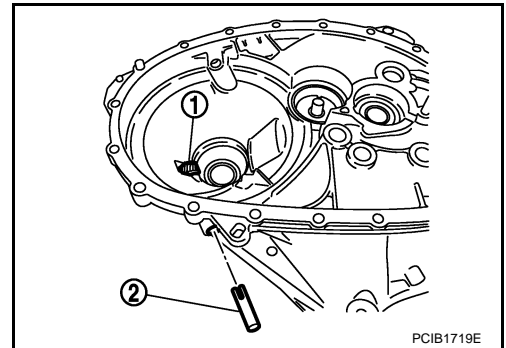

2. Install two way connector (1) into clutch housing.

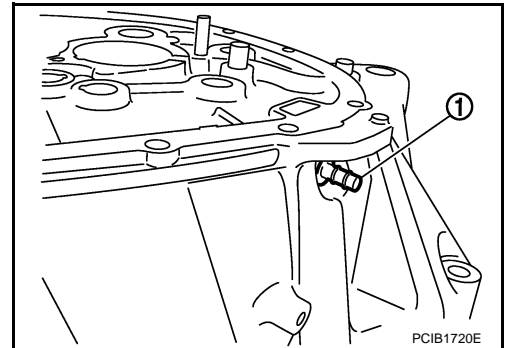

3. Install bushings (1) until they are flush with end face of clutch housing using a suitable tool (A).

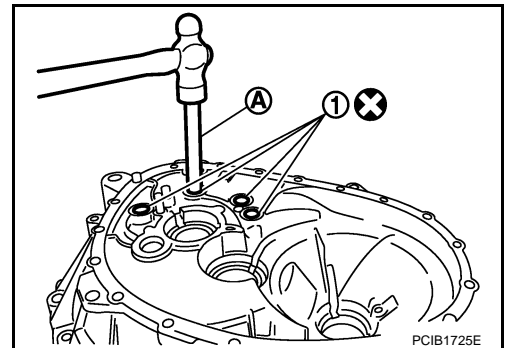

# TRANSAXLE ASSEMBLY

[RS6F94R]

## < SERVICE INFORMATION >

4. Install oil channel and mainshaft front bearing outer race into clutch housing using Tool (A).

**Tool number** A: KV38100200 ( — )

**CAUTION:**

**Do not reuse oil channel.**

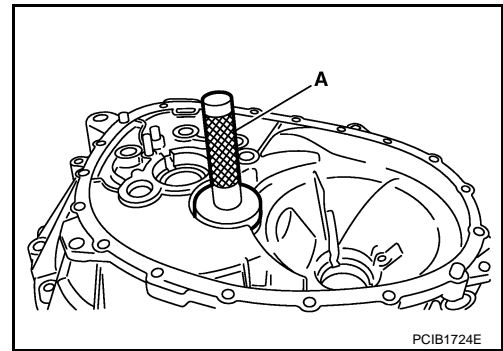

5. Install input shaft oil seal (1) into clutch housing using Tool (A).

**Tool number** A: ST33220000 ( — )

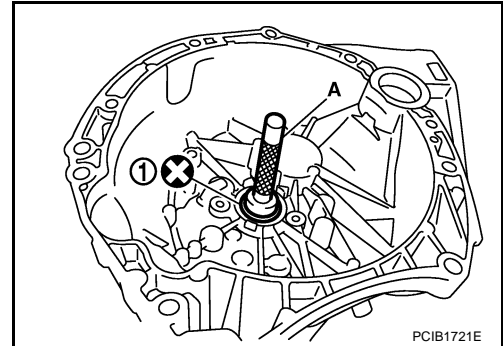

6. Install snap ring (1) and oil channel (2) onto transaxle case.

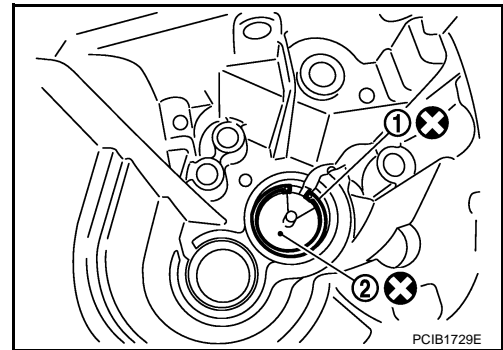

7. Install bearing preloading shim and mainshaft rear bearing outer race into transaxle case using Tool (A).

**Tool number** A: KV38100200 ( — )

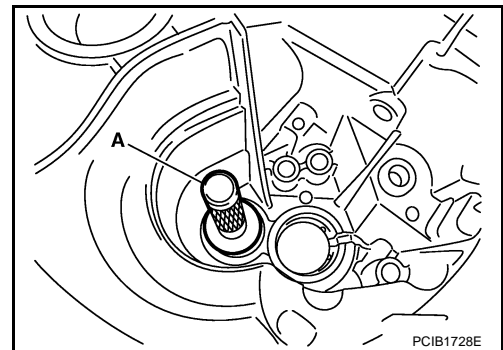

8. Install bushings (1) into transaxle case using a suitable tool (A).

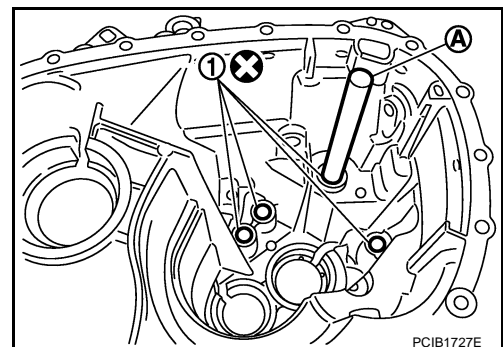

A  
B  
MT  
D  
E  
F  
G  
H  
I  
J  
K  
L  
M  
N  
O  
P

# TRANSAXLE ASSEMBLY

[RS6F94R]

## < SERVICE INFORMATION >

9. Install oil gutter (1) onto transaxle case.

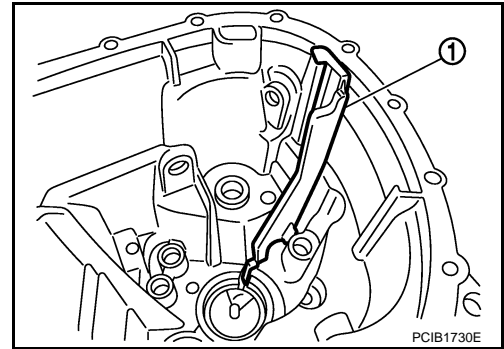

10. Install shift lever oil seal (1) into transaxle case using a suitable tool (A).

**CAUTION:**

**Do not reuse shift lever oil seal.**

11. Install select lever oil seal and bushings into transaxle case using a suitable tool.

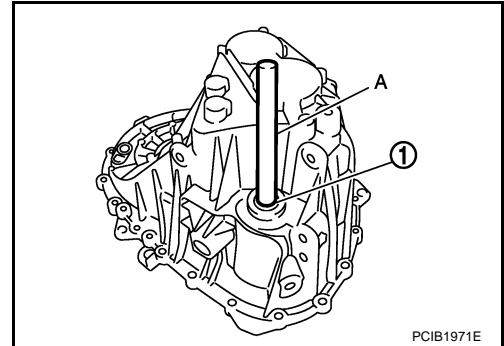

12. Install shift finger (1) into transaxle case.

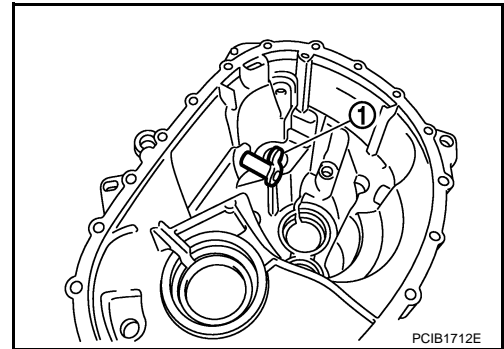

13. Install select lever (1) and then install retaining pin.

**CAUTION:**

**Do not reuse retaining pin.**

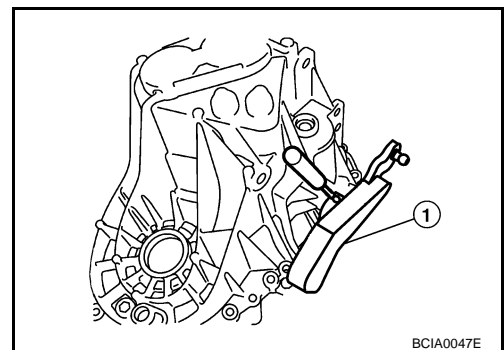

14. Install shim and differential side bearing outer race (transaxle case side) into transaxle case using Tool (A).

**Tool number**     **A: ST33400001 (J-26082)**

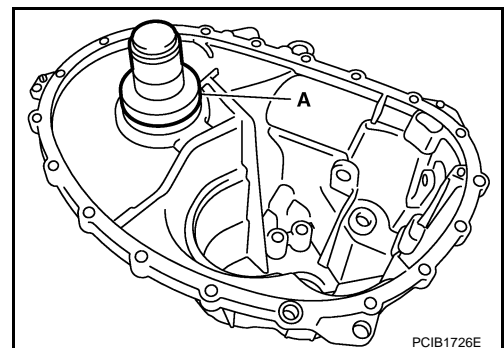



# TRANSAXLE ASSEMBLY

[RS6F94R]

## < SERVICE INFORMATION >

15. Install differential side bearing outer race (clutch housing side) into clutch housing using Tool (A).

**Tool number** A: KV38100200 ( — )

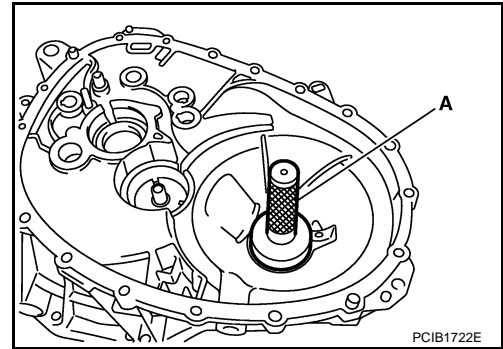

16. Install differential side oil seals (1) into clutch housing and transaxle case using Tool (A).

**Tool number** A: KV38100300 (J-25523)

17. Install magnet onto clutch housing.  
18. Install final drive assembly into clutch housing.

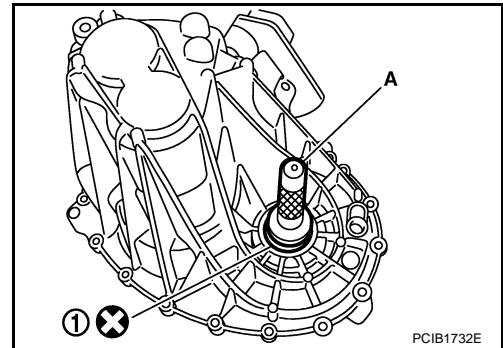

19. Install input shaft assembly (1), mainshaft assembly (2) and 1st-2nd fork rod assembly (3) into clutch housing.  
20. Install spring washer located under the reverse idler shaft.

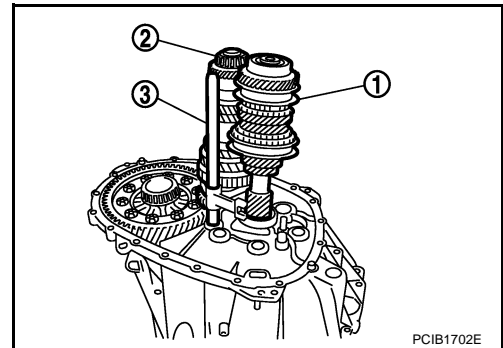

21. Install reverse gear assembly (1) according to the following.  
a. Lift up the input shaft assembly (2) and mainshaft assembly (3).  
b. Install reverse gear assembly (1) and reverse fork rod (4) to clutch housing.

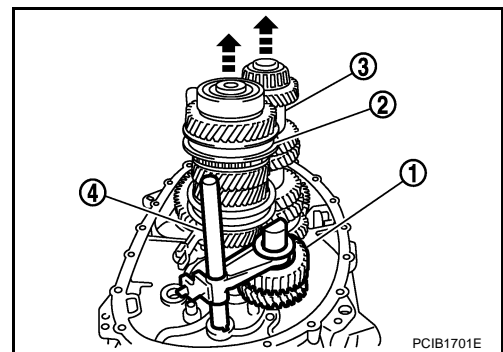

22. While lifting up fork rod (1), install 3rd-4th and 5th-6th fork rod assembly to clutch housing.

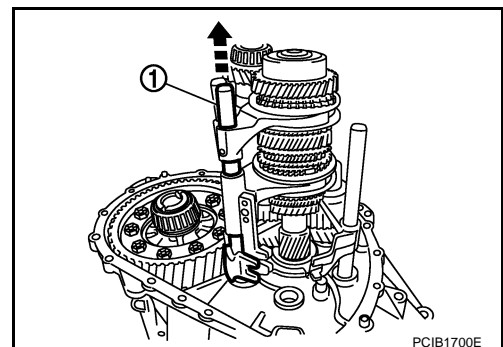

A  
B  
MT  
D  
E  
F  
G  
H  
I  
J  
K  
L  
M  
N  
O  
P

# TRANSAXLE ASSEMBLY

[RS6F94R]

## < SERVICE INFORMATION >

23. Install retaining pin into 5th-6th shift fork using a suitable tool.

**CAUTION:**

**Do not reuse retaining pin.**

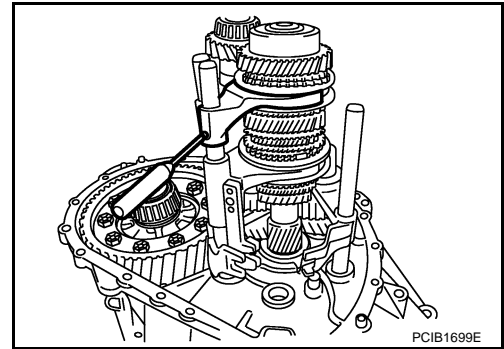

24. Move 1st-2nd fork rod (1), 3rd-4th and 5th-6th fork rod assembly (2), and reverse fork rod (3) to neutral position.

25. Install selector (4) into clutch housing.

26. Install spring of selector into return bushing.

27. Apply recommended sealant onto the mating surface of transaxle case.

- Use Genuine Silicone RTV or equivalent. Refer to [GI-42, "Recommended Chemical Product and Sealant"](#).

**CAUTION:**

- Remove old sealant adhering to the mating surfaces. Also remove any moisture, oil, or foreign material adhering to both mating surfaces.
- Check for damage on the mating surface.
- Apply a continuous bead of liquid gasket to the mating surface.

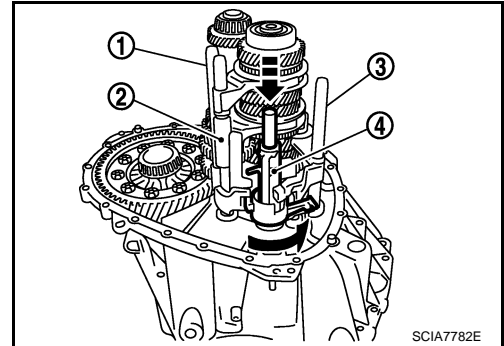

28. Engage shift finger and selector by moving select lever (1). Install transaxle case to clutch housing.

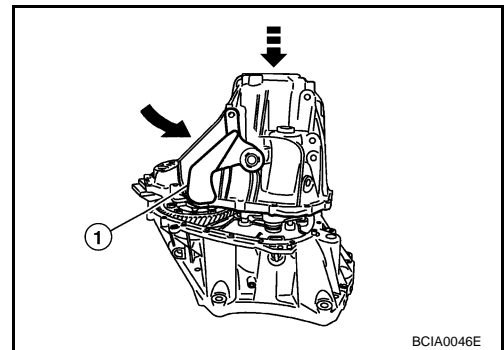

29. Install seal washer and reverse idler shaft bolt (←), and then tighten bolt to specification.

**CAUTION:**

**Do not reuse seal washer.**

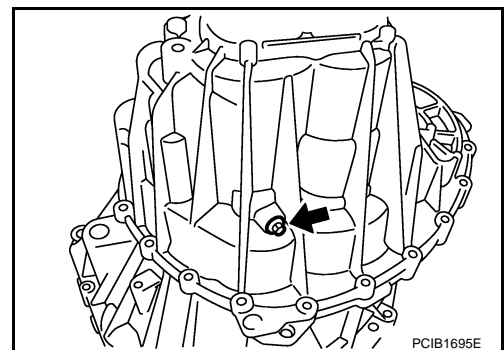

# TRANSAXLE ASSEMBLY

[RS6F94R]

< SERVICE INFORMATION >

30. Tighten bolts to specification.

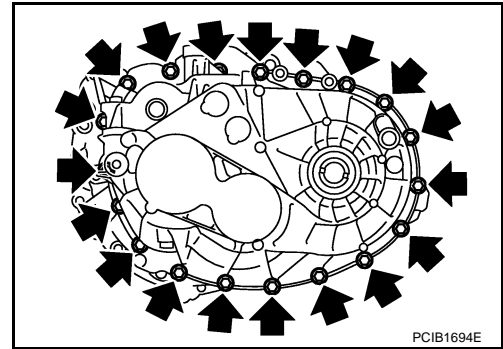

31. Apply sealant to the threads of position switch (1). Then install it into transaxle case and tighten to specification.

- Use Genuine Silicone RTV or equivalent. Refer to [GI-42, "Recommended Chemical Product and Sealant"](#).

32. Install bracket (2), and tighten bolt to specification.

33. Install shift lever (3), and then install retaining pin using a suitable tool.

**CAUTION:**

**Do not reuse retaining pin.**

34. Install CSC onto clutch housing.

35. Install a new gasket onto drain plug, and then install it into clutch housing using the socket. Tighten drain plug to specification.

36. Install a new gasket onto filler plug, and then install it into transaxle case. Tighten filler plug to specification.

**CAUTION:**

- Do not reuse gasket.
- After oil is filled, tighten filler plug to specification.

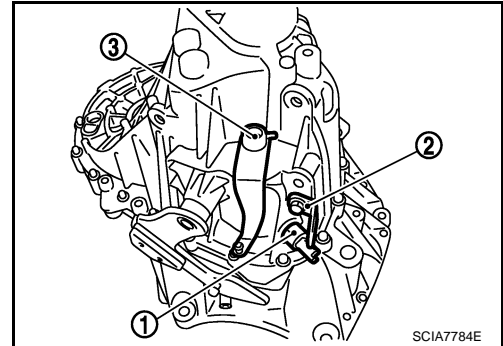

A  
B  
MT  
D  
E  
F  
G  
H  
I  
J  
K  
L  
M  
N  
O  
P

## INPUT SHAFT AND GEARS

### Disassembly and Assembly

INFOID:000000001850865

#### GENERAL PRECAUTIONS

- Do not reuse snap ring.
- Position input shaft on the vise with back plate and remove gears and snap rings.
- For installation and removal of snap ring, position snap ring pliers and flat pliers at both sides of snap ring. Stretch snap ring, and move it with flat pliers.
- Disassemble gear components putting matching marks on the parts that do not affect any functions.

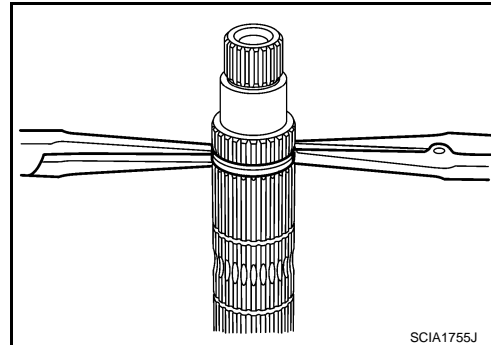

#### DISASSEMBLY

1. Remove snap ring (1).

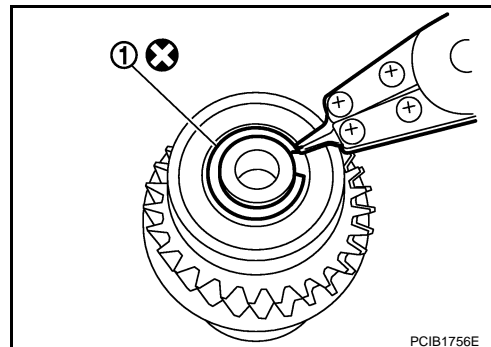

2. Install the suitable tools (A) onto input shaft rear bearing (1), and remove input shaft rear bearing (1) from input shaft.

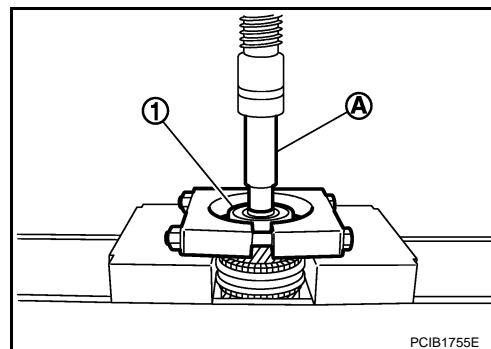

3. Remove washer (1), 6th input gear (2) and 5th-6th synchronizer assembly (3).
4. Remove needle bearing.

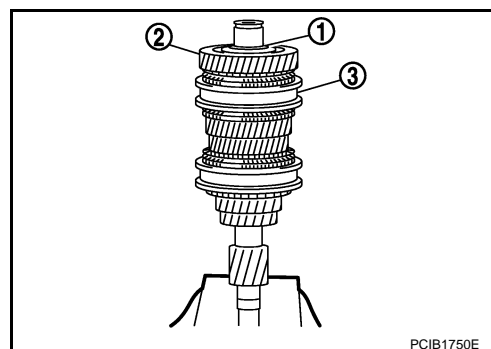

# INPUT SHAFT AND GEARS

[RS6F94R]

## < SERVICE INFORMATION >

5. Remove snap ring (1), washer and 5th input gear (2).
6. Remove washer.

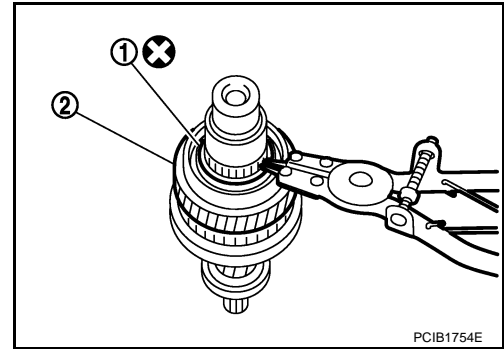

7. Remove snap ring (1), washer, 4th input gear (2) and 3rd-4th synchronizer assembly (3).

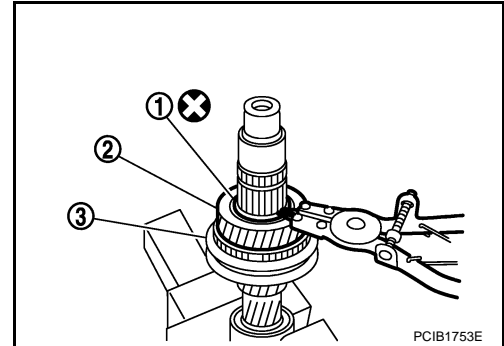

8. Remove snap ring (1), washer and 3rd input gear (2).

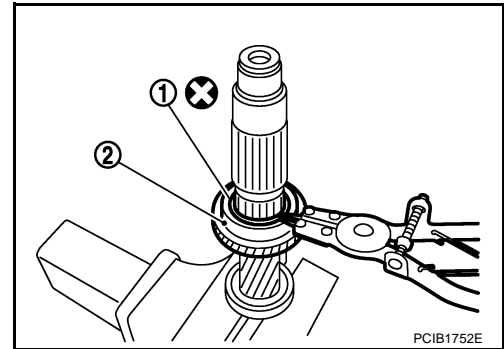

9. Remove input shaft front bearing (1) from input shaft using a suitable tool.

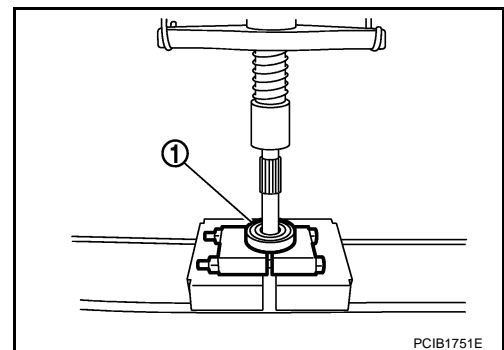

## INSPECTION AFTER DISASSEMBLY

Input Shaft and Gears

A  
B  
MT  
D  
E  
F  
G  
H  
I  
J  
K  
L  
M  
N  
O  
P

# INPUT SHAFT AND GEARS

[RS6F94R]

## < SERVICE INFORMATION >

Check items below. If necessary, replace them with new ones.

- Damage, peeling, dent, uneven wear, bending, and other non-standard conditions of the shaft.
- Excessive wear, damage, peeling, and other non-standard conditions of the gears.

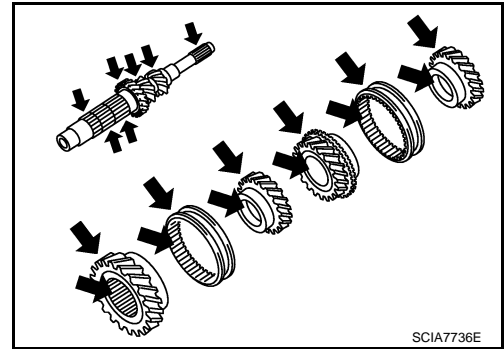

### Synchronizer

Check items below. If necessary, replace them with new ones.

- Damage and excessive wear of contact surfaces of coupling sleeve, synchronizer hub and insert key.
- Coupling sleeve and synchronizer hub must move smoothly.

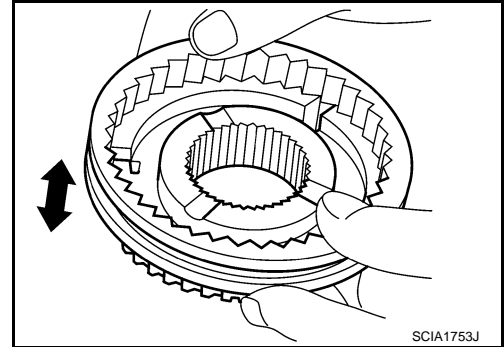

- If any crack, damage, or excessive wear is found on cam face of baulk ring or working face of insert, replace it.

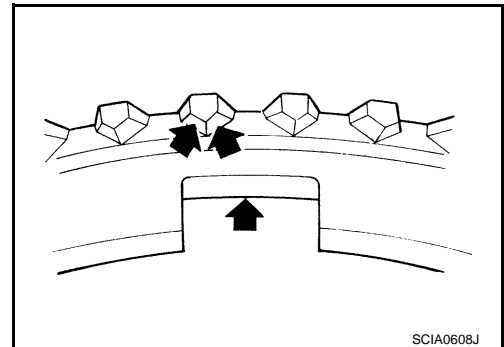

### Bearing

Check items below. If necessary, replace them with new ones.

- Damage and rough rotation of bearing

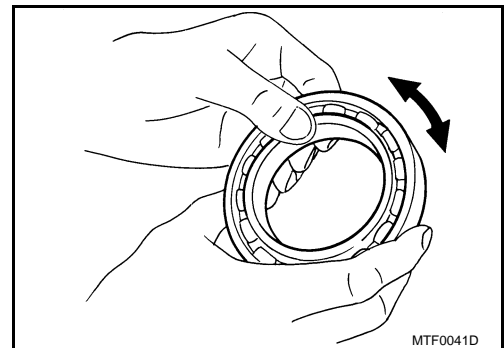

## ASSEMBLY

Note the following. Assembly is in the reverse order of disassembly. Refer to [MT-18, "Disassembly and Assembly"](#).

# INPUT SHAFT AND GEARS

[RS6F94R]

## < SERVICE INFORMATION >

- Press-fit the input shaft front bearing (1) onto the input shaft using a suitable tool (A).

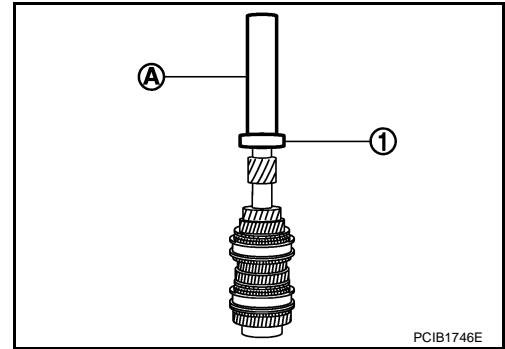

- Press-fit the input shaft rear bearing (1) onto the input shaft using a suitable tool (A), and Tool (B).

Tool number B: ST36720030 ( — )

### CAUTION:

- Do not reuse snap ring.
- Make sure that snap ring is securely installed in the groove.

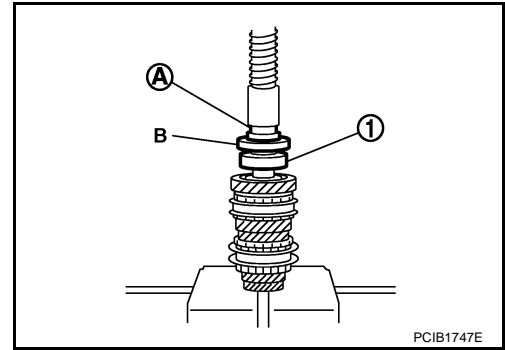

- Be careful with the orientation of 3rd-4th synchronizer hub.  
A: 3rd input gear side  
B: 4th input gear side

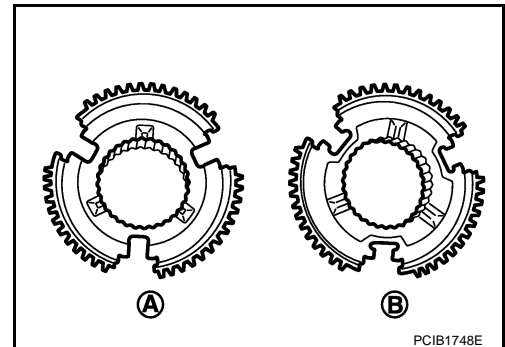

- Be careful with the orientation of 5th-6th synchronizer hub.  
A: 5th input gear side  
B: 6th input gear side

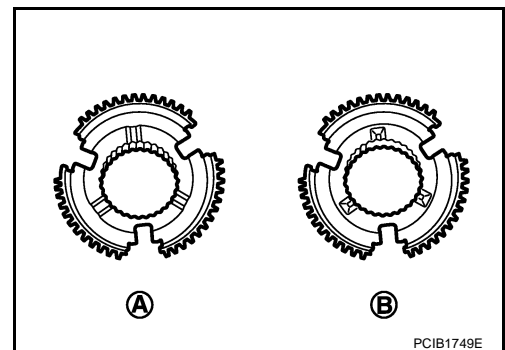

A  
B  
MT  
D  
E  
F  
G  
H  
I  
J  
K  
L  
M  
N  
O  
P

## MAINSHAFT AND GEARS

### Disassembly and Assembly

INFOID:000000001850866

#### GENERAL PRECAUTIONS

- Do not reuse snap rings.
- Position mainshaft on the vise with back plate and remove gears and snap rings.
- For installation and removal of snap ring, position snap ring pliers and flat pliers at both sides of snap ring. Stretch snap ring, and move it with flat pliers.
- Disassemble gear components putting matching marks on the parts that do not affect any functions.

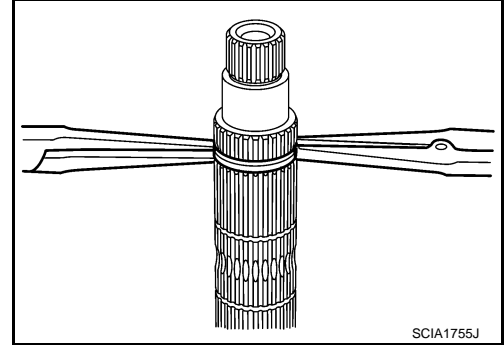

#### DISASSEMBLY

1. Remove snap ring (1).

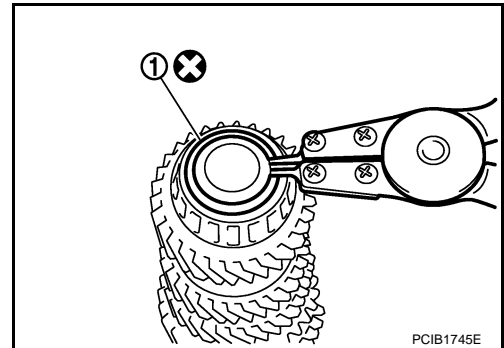

2. Install Tool (A) and suitable tool onto 6th main gear (1), and remove mainshaft rear bearing inner race (2) and 6th main gear (1) from mainshaft.

**Tool number**    **A: ST33052000 ( — )**

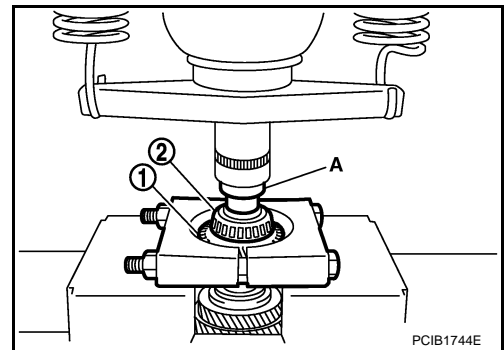

3. Install Tool (A) and suitable tool onto 4th main gear (1), and remove 5th main gear (2), and 4th main gear (1) from mainshaft.

**Tool number**    **A: ST33052000 ( — )**

4. Remove intermediate adjusting shim.

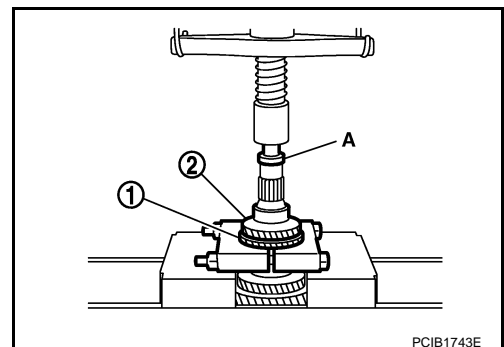



# MAINSHAFT AND GEARS

[RS6F94R]

## < SERVICE INFORMATION >

5. Install Tool (A) and suitable tool onto 1st main gear (1), and remove 1st main gear (1), 1st-2nd synchronizer assembly (2), 2nd main gear (3), bushing, and 3rd main gear (4) from mainshaft.

**Tool number**    **A: ST33052000 ( — )**

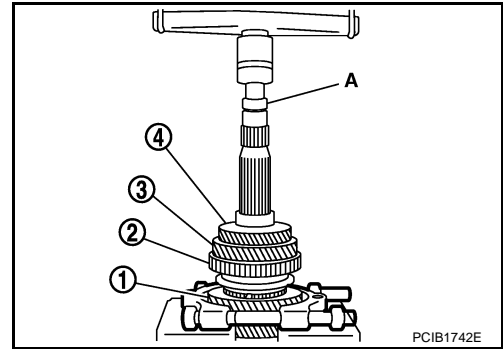

6. Install Tool (A) and suitable tool onto mainshaft front bearing inner race (1), and remove mainshaft front bearing inner race (1) from mainshaft.

**Tool number**    **A: ST33052000 ( — )**

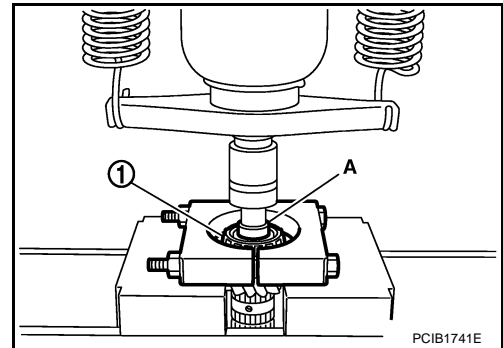

## INSPECTION AFTER DISASSEMBLY

### Mainshaft and Gears

Check items below. If necessary, replace them with new ones.

- Damage, peeling, dent, uneven wear, bending, and other non-standard conditions of the shaft.
- Excessive wear, damage, peeling, and other non-standard conditions of the gears.

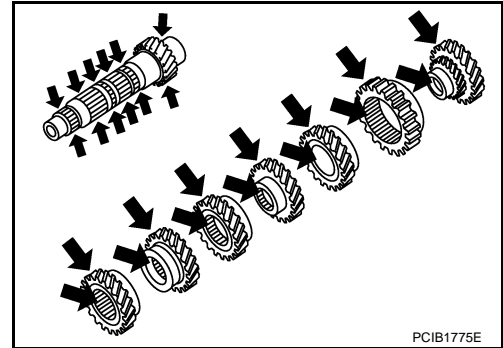

### Synchronizer

Check items below. If necessary, replace them with new ones.

- Damage and excessive wear of contact surfaces of coupling sleeve, synchronizer hub, insert key.
- Coupling sleeve and synchronizer hub must move smoothly.

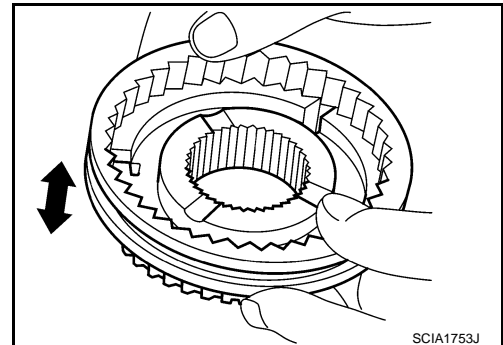

A  
B  
MT  
D  
E  
F  
G  
H  
I  
J  
K  
L  
M  
N  
O  
P

# MAINSHAFT AND GEARS

[RS6F94R]

## < SERVICE INFORMATION >

- If any crack, damage, or excessive wear is found on cam face of baulk ring or working face of insert, replace it.

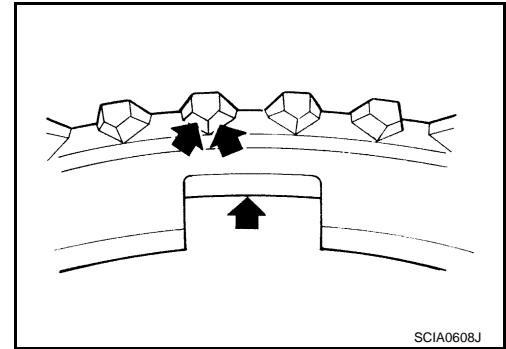

## Bearing

Check items below. If necessary, replace them with new ones.

### CAUTION:

**When replacing tapered roller bearing, replace outer and inner races as a set.**

- Damage and rough rotation of bearing

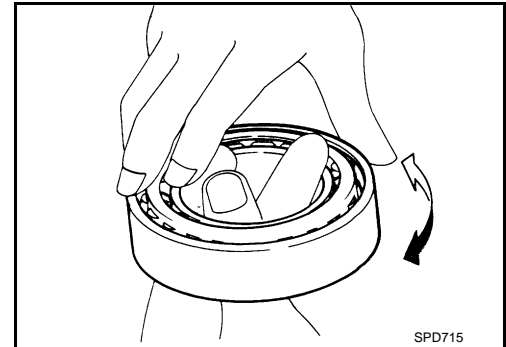

### CAUTION:

**Bearing preloading shim:** after the intermediate adjusting shim and/or the 6th main gear, 5th main gear, and 4th main gear have been replaced, it is necessary to modify the bearing preload setting by changing the bearing preload shim.

- Replacing the intermediate adjusting shim.
  - Increase the size of the bearing preload shim, if the replaced intermediate adjusting shim is thinner than the shim used before.
  - Decrease the size of the bearing preload shim, if the replaced intermediate adjusting shim is thicker than the shim used before.
- Replacing the 6th main gear, 5th main gear, and 4th main gear.
  - Measure the thickness of the main gear used before and the new main gear.
  - Increase the thickness of the bearing preload shim, if the difference is smaller than 0.025 mm (0.0010 in).
  - Decrease the thickness of the bearing preload shim, if the difference is greater than 0.025 mm (0.0010 in).

## ASSEMBLY

1. Press-fit the mainshaft front bearing inner race (1) onto the mainshaft using Tool (A).

**Tool number**    **A: ST36720030 ( — )**

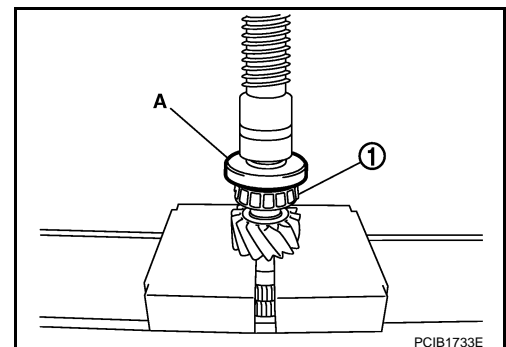

# MAINSHAFT AND GEARS

[RS6F94R]

< SERVICE INFORMATION >

- Install 1st main gear (1), and 1st-2nd synchronizer assembly (2) onto the mainshaft.
- Press-fit the bushing (3) onto the mainshaft using Tool (A).

**Tool number**    **A: KV32102700 ( — )**

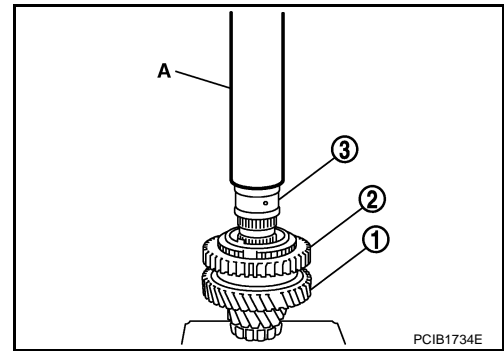

- Press-fit 3rd main gear (1) onto the mainshaft with Tool (A) after installing the 2nd main gear (2) and the 3rd main gear (1) onto the mainshaft.

**Tool number**    **A: KV32102700 ( — )**

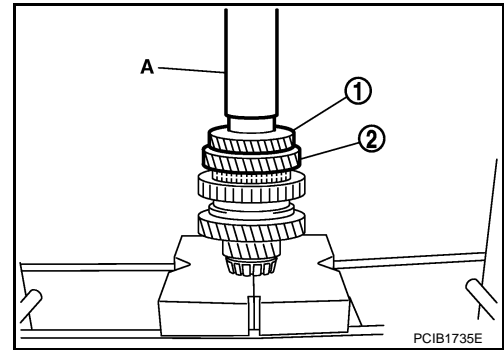

- Select the thickness of the intermediate adjusting shim (1) needed by measuring the distance "L" between the base of the mainshaft (2) and the top of the 3rd main gear (3). Refer to the following table to determine the thickness of the adjusting shim.

Unit: mm (in)

Distance "L"	Adjusting shim thickness
147.690 – 147.666 (5.8146 – 5.8136)	1.500 (0.0591)
147.665 – 147.641 (5.8136 – 5.8126)	1.525 (0.0600)
147.640 – 147.616 (5.8126 – 5.8116)	1.550 (0.0610)
147.615 – 147.591 (5.8116 – 5.8107)	1.575 (0.0620)
147.590 – 147.566 (5.8106 – 5.8097)	1.600 (0.0630)
147.565 – 147.541 (5.8096 – 5.8087)	1.625 (0.0640)
147.540 – 147.516 (5.8086 – 5.8077)	1.650 (0.0650)
147.515 – 147.491 (5.8077 – 5.8067)	1.675 (0.0659)
147.490 – 147.466 (5.8067 – 5.8057)	1.700 (0.0669)
147.465 – 147.441 (5.8057 – 5.8048)	1.725 (0.0679)
147.440 – 147.416 (5.8047 – 5.8038)	1.750 (0.0689)
147.415 – 147.391 (5.8037 – 5.8028)	1.775 (0.0699)

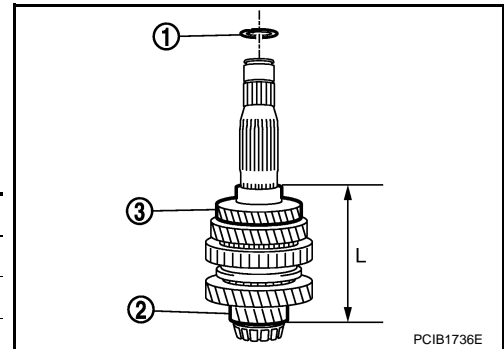

- Install selected intermediate adjusting shim.
- Press-fit the 4th main gear (1) onto the mainshaft using Tool (A).

**Tool number**    **A: KV32102700 ( — )**

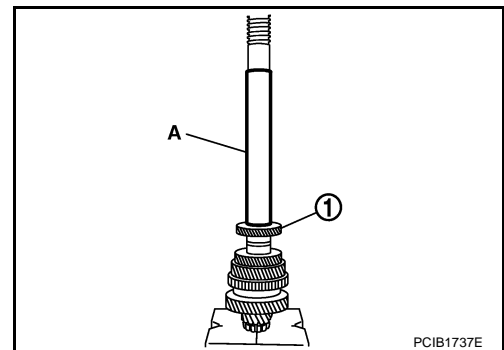

A  
B  
MT  
D  
E  
F  
G  
H  
I  
J  
K  
L  
M  
N  
O  
P

# MAINSHAFT AND GEARS

< SERVICE INFORMATION >

[RS6F94R]

8. Press-fit the 5th main gear (1) onto the mainshaft using Tool (A).

**Tool number**    **A: KV32102700 ( — )**

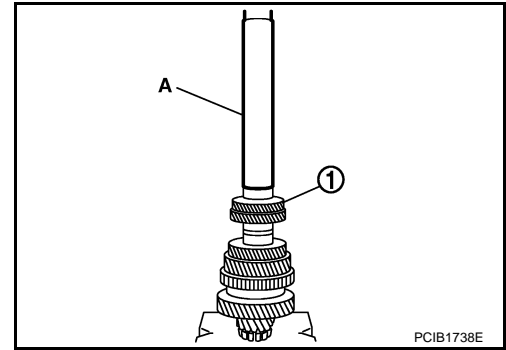

9. Press-fit the 6th main gear (1) onto the mainshaft using Tool (A).

**Tool number**    **A: KV32102700 ( — )**

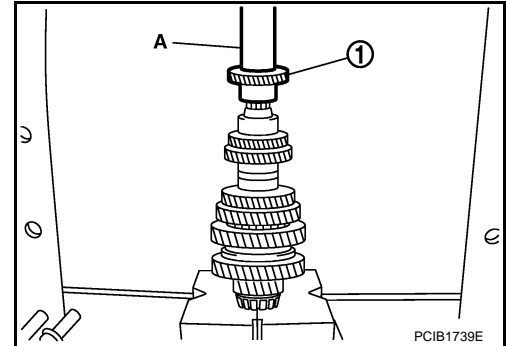

10. Press-fit the mainshaft rear bearing inner race (1) onto the mainshaft using Tool (A).

**Tool number**    **A: ST30901000 (J-26010-01)**

11. Install snap ring onto mainshaft.

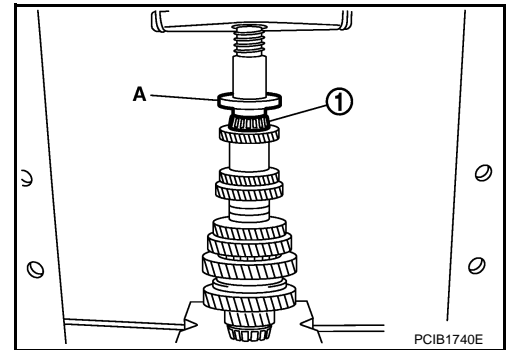

# REVERSE IDLER SHAFT AND GEARS

< SERVICE INFORMATION >

[RS6F94R]

## REVERSE IDLER SHAFT AND GEARS

### Disassembly and Assembly

INFOID:000000001850867

#### DISASSEMBLY

1. Remove reverse output gear (1).

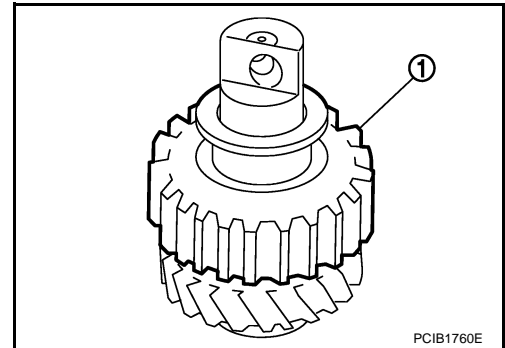

2. Remove snap ring (1).

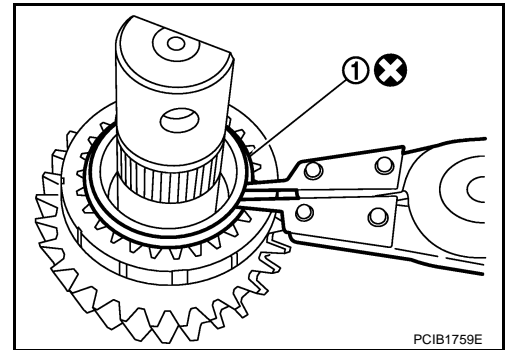

3. Remove reverse baulk ring (1) and return spring (2).

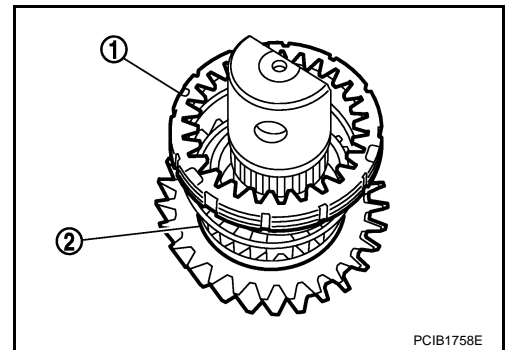

4. Remove snap ring (1), lock washer (2), reverse input gear (3) and washer.

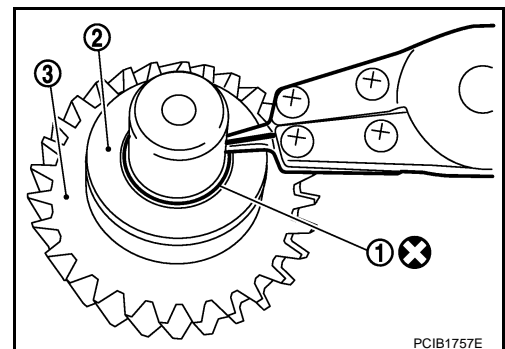

A  
B  
MT  
D  
E  
F  
G  
H  
I  
J  
K  
L  
M  
N  
O  
P

## REVERSE IDLER SHAFT AND GEARS

[RS6F94R]

### < SERVICE INFORMATION >

5. Remove needle bearings (1) from reverse idler shaft.
6. Remove washer from reverse idler shaft.

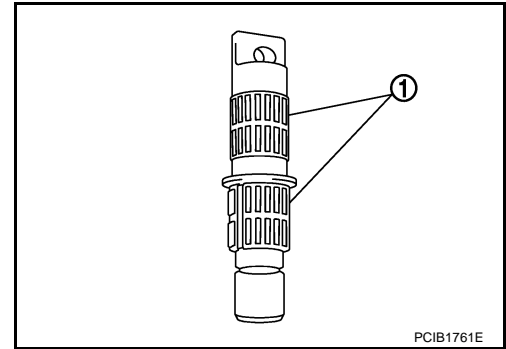

### ASSEMBLY

Assembly is in the reverse order of disassembly. Refer to [MT-18, "Disassembly and Assembly"](#).

#### **CAUTION:**

- Do not reuse snap ring.
- Make sure that snap ring is securely installed in the groove.

## FINAL DRIVE

### Disassembly and Assembly

INFOID:000000001850868

#### DISASSEMBLY

1. Remove differential side bearing inner race (clutch housing side) (1) using Tool (A) and a suitable tool.

**Tool number    A: ST33061000 (J-8107-2)**

2. Remove speedometer drive gear.

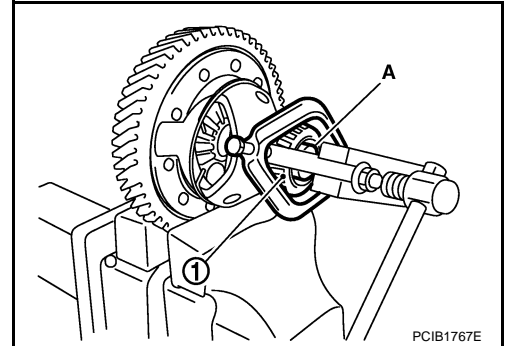

3. Remove final gear bolts (1), and then separate the final gear (2) from differential case.

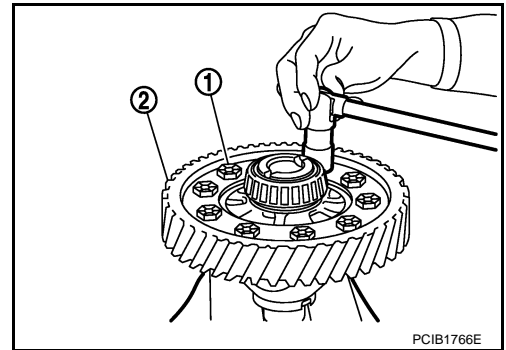

4. Remove differential side bearing inner race (transaxle case side) (1) using a suitable tool (A).

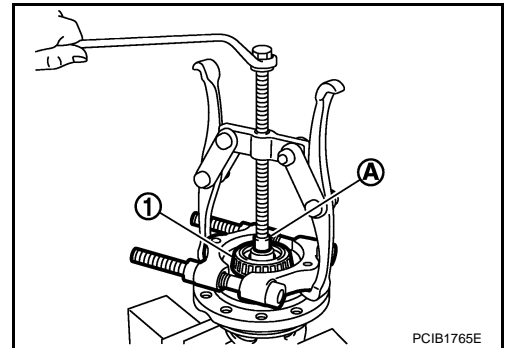

5. Remove lock ring (1) from differential case.
6. Remove pinion mate shaft, pinion mate gears, side gears and thrust washer from differential case.

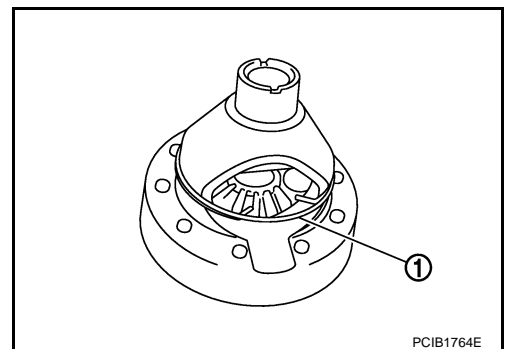

#### INSPECTION AFTER DISASSEMBLY

Gear, Washer, Shaft and Case

A  
B  
MT  
D  
E  
F  
G  
H  
I  
J  
K  
L  
M  
N  
O  
P

# FINAL DRIVE

## < SERVICE INFORMATION >

[RS6F94R]

- Check side gears, thrust washer, pinion mate shaft, pinion mate gears, lock ring and differential case. If necessary, replace with a new one.

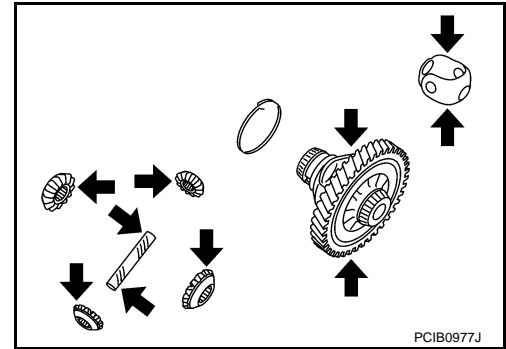

### Bearing

- Check for bearing damage and rough rotation. If necessary, replace with a new one.

#### **CAUTION:**

**When replacing tapered roller bearing, replace outer and inner races as a set.**

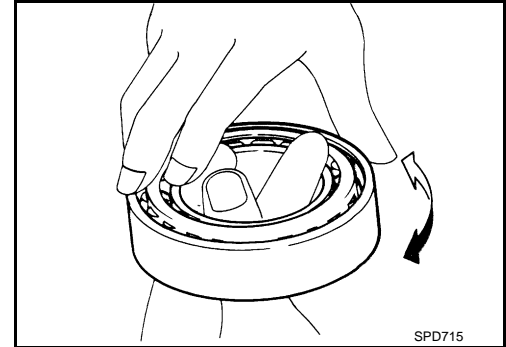

### ASSEMBLY

1. Install pinion mate shaft, pinion mate gears, side gears and thrust washer into differential case.
2. Install lock ring (1) onto differential case.  
**CAUTION:**  
**Make sure that lock ring is securely installed in the groove.**
3. Install final gear into differential case, and tighten final gear bolts to specification. Refer to [MT-18. "Disassembly and Assembly"](#).
4. Install speedometer drive gear onto differential case.

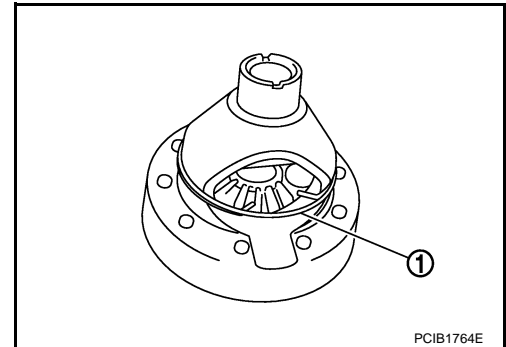

5. Press-fit the differential side bearing inner race (clutch housing side) onto the differential case using a suitable tool (A).

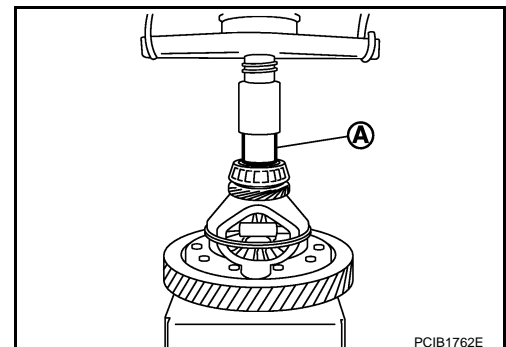



# FINAL DRIVE

[RS6F94R]

## < SERVICE INFORMATION >

6. Press-fit the differential side bearing inner race (transaxle case side) onto the differential case using a suitable tool (A).

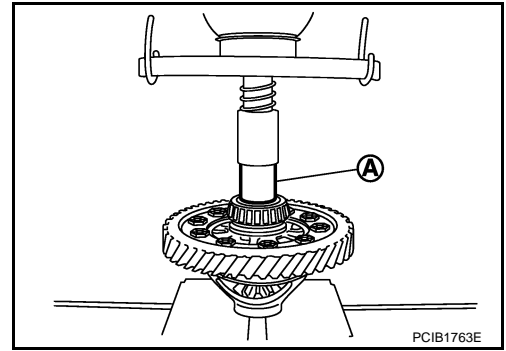

A

B

MT

D

E

F

G

H

I

J

K

L

M

N

O

P

## SHIFT CONTROL

### Inspection

INFOID:000000001850869

- Check contact surface and sliding surface of fork rod and shift fork for wear, damage, and bend. Replace if necessary.

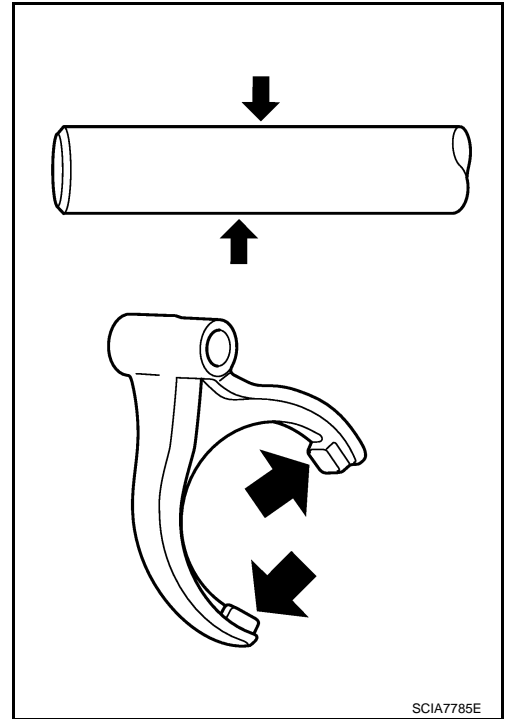

# SERVICE DATA AND SPECIFICATIONS (SDS)

< SERVICE INFORMATION >

[RS6F94R]

## SERVICE DATA AND SPECIFICATIONS (SDS)

### General Specification

INFOID:000000001850870

Engine type		MR20DE	
Transaxle model		RS6F94R	
Number of speeds		6	
Synchromesh type		Warner	
Shift pattern		<p style="text-align: center;">PCIB1769E</p>	
Gear ratio	1st	3.727	
	2nd	2.105	
	3rd	1.519	
	4th	1.171	
	5th	0.914	
	6th	0.767	
	Reverse	3.687	
	Final gear	3.933	
Number of teeth	Input gear	1st	11
		2nd	19
		3rd	27
		4th	35
		5th	35
		6th	43
		Reverse	11
		Main gear	1st
	2nd		40
	3rd		41
	4th		41
	5th		32
	6th		33
	Reverse		42
	Reverse idler gear		Input/Output
	Final gear	Final gear/Pinion	59/15
Side gear/Pinion mate gear		13/10	
Oil capacity	$\ell$ (US pt, Imp pt)	Approx. 2.0 (4-1/4, 3-1/2)	
Remarks	Reverse synchronizer	Installed	
	Triple-cone synchronizer	1st and 2nd	

A  
B  
MT  
D  
E  
F  
G  
H  
I  
J  
K  
L  
M  
N  
O  
P

## SERVICE INFORMATION

### PRECAUTIONS

#### Precaution for Supplemental Restraint System (SRS) "AIR BAG" and "SEAT BELT PRE-TENSIONER"

INFOID:000000001850871

The Supplemental Restraint System such as "AIR BAG" and "SEAT BELT PRE-TENSIONER", used along with a front seat belt, helps to reduce the risk or severity of injury to the driver and front passenger for certain types of collision. This system includes seat belt switch inputs and dual stage front air bag modules. The SRS system uses the seat belt switches to determine the front air bag deployment, and may only deploy one front air bag, depending on the severity of a collision and whether the front occupants are belted or unbelted. Information necessary to service the system safely is included in the SRS and SB section of this Service Manual.

**WARNING:**

- To avoid rendering the SRS inoperative, which could increase the risk of personal injury or death in the event of a collision which would result in air bag inflation, all maintenance must be performed by an authorized NISSAN/INFINITI dealer.
- Improper maintenance, including incorrect removal and installation of the SRS, can lead to personal injury caused by unintentional activation of the system. For removal of Spiral Cable and Air Bag Module, see the SRS section.
- Do not use electrical test equipment on any circuit related to the SRS unless instructed to in this Service Manual. SRS wiring harnesses can be identified by yellow and/or orange harnesses or harness connectors.

#### Service Notice or Precaution

INFOID:000000001850872

- Do not reuse transaxle oil, once it has been drained.
- Check oil level or replace oil with vehicle on level surface.
- During removal or installation, keep inside of transaxle clear of dust or dirt.
- Check for the correct installation status prior to removal or disassembly. If matching marks are required, be certain they do not interfere with the function of the parts they are applied.
- In principle, tighten bolts or nuts gradually in several steps working diagonally from inside to outside. If tightening sequence is specified, use it.
- Be careful not to damage sliding surfaces and mating surfaces.

# PREPARATION

< SERVICE INFORMATION >

[RS6F52A]

## PREPARATION

### Special Service Tool

INFOID:000000001850873

The actual shapes of Kent-Moore tools may differ from those of special service tools illustrated here.

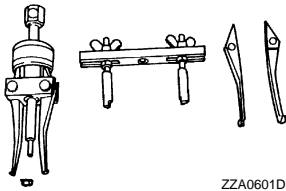
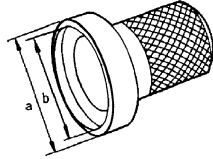
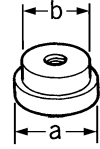
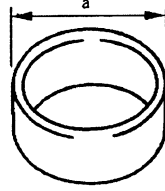
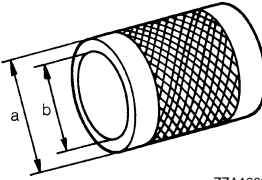
Tool number (Kent-Moore No.) Tool name		Description
KV381054S0 (J-34286) Puller	 <p style="text-align: center;">ZZA0601D</p>	<ul style="list-style-type: none"> <li>Removing differential side bearing outer race (clutch housing side)</li> <li>Removing differential side bearing outer race (transaxle case side)</li> <li>Removing mainshaft front bearing</li> </ul>
ST33400001 (J-26082) Drift	 <p style="text-align: center;">ZZA0814D</p>	Installing differential side oil seal (clutch housing side) <b>a: 60 mm (2.36 in) dia.</b> <b>b: 47 mm (1.85 in) dia.</b>
ST35321000 ( — ) Drift	 <p style="text-align: center;">ZZA1000D</p>	<ul style="list-style-type: none"> <li>Installing input shaft oil seal</li> <li>Installing reverse main gear</li> <li>Installing 1st main gear bushing</li> <li>Installing 1st-2nd synchronizer hub assembly</li> <li>Installing 2nd main gear bushing</li> <li>Installing 3rd main gear</li> </ul> <b>a: 49 mm (1.93 in) dia.</b> <b>b: 41 mm (1.61 in) dia.</b>
KV40105320 ( — ) Drift	 <p style="text-align: center;">ZZA0898D</p>	Installing differential side bearing outer race (clutch housing side) <b>a: 88 mm (3.46 in) dia.</b>
ST33200000 (J-26082) Drift	 <p style="text-align: center;">ZZA1002D</p>	<ul style="list-style-type: none"> <li>Installing mainshaft front bearing</li> <li>Installing 6th input gear bushing</li> <li>Installing 4th main gear</li> <li>Installing 5th main gear</li> <li>Installing 6th main gear</li> </ul> <b>a: 60 mm (2.36 in) dia.</b> <b>b: 44.5 mm (1.752 in) dia.</b>

A  
B  
MT  
D  
E  
F  
G  
H  
I  
J  
K  
L  
M  
N  
O  
P

# PREPARATION

< SERVICE INFORMATION >

[RS6F52A]

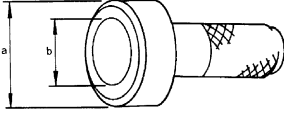
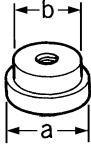
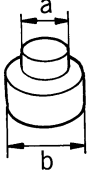
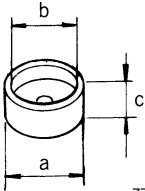
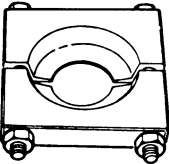
Tool number (Kent-Moore No.) Tool name		Description
ST30720000 (J-25405) Drift	 <p style="text-align: center; font-size: small;">ZZA0811D</p>	<ul style="list-style-type: none"> <li>• Installing differential side oil seal (transaxle case side)</li> <li>• Installing differential side bearing outer race (clutch housing side)</li> <li>• Installing differential side bearing outer race (transaxle case side)</li> <li>• Installing mainshaft rear bearing</li> <li>• Installing differential side bearing (clutch housing side)</li> <li>• Installing differential side bearing (transaxle case side)</li> </ul> <p><b>a: 77 mm (3.03 in) dia.</b> <b>b: 55.5 mm (2.185 in) dia.</b></p>
ST33061000 (J-8107-2) Drift	 <p style="text-align: center; font-size: small;">ZZA1000D</p>	<ul style="list-style-type: none"> <li>• Installing bore plug</li> <li>• Removing differential side bearing (transaxle case side)</li> <li>• Removing differential side bearing (clutch housing side)</li> </ul> <p><b>a: 38 mm (1.50 in) dia.</b> <b>b: 28.5 mm (1.122 in) dia.</b></p>
ST33052000 ( — ) Drift	 <p style="text-align: center; font-size: small;">ZZA1023D</p>	<ul style="list-style-type: none"> <li>• Removing input shaft rear bearing</li> <li>• Removing 6th input gear, 6th input gear bushing, 5th-6th synchronizer hub assembly, and 5th input gear</li> <li>• Removing 5th input gear bushing, 4th input gear, 4th input gear bushing, 3rd-4th synchronizer hub assembly, and 3rd input gear</li> <li>• Installing input shaft front bearing</li> <li>• Removing mainshaft rear bearing</li> <li>• Removing 6th main gear</li> <li>• Removing 4th main gear and 5th main gear</li> </ul> <p><b>a: 22 mm (0.87 in) dia.</b> <b>b: 28 mm (1.10 in) dia.</b></p>
KV40105020 ( — ) Drift	 <p style="text-align: center; font-size: small;">ZZA1133D</p>	Removing 3rd main gear, 2nd main gear, 2nd main gear bushing, 1st-2nd synchronizer hub assembly, 1st main gear, 1st main gear bushing, and reverse main gear <p><b>a: 39.7 mm (1.563 in) dia.</b> <b>b: 35 mm (1.38 in) dia.</b> <b>c: 15 mm (0.59 in)</b></p>
ST30031000 (J-22912-01) Puller	 <p style="text-align: center; font-size: small;">ZZA0537D</p>	Measuring wear of inner baulk ring

# PREPARATION

< SERVICE INFORMATION >

[RS6F52A]

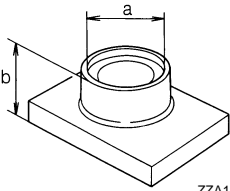
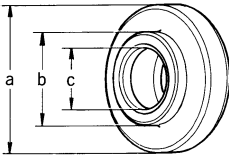
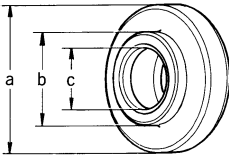
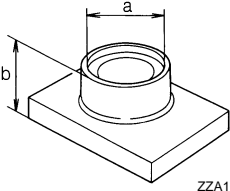
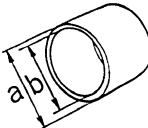
Tool number (Kent-Moore No.) Tool name	Description
KV40105710 ( — ) Press stand  ZZA1058D	<ul style="list-style-type: none"> <li>• Installing 3rd-4th synchronizer hub assembly</li> <li>• Installing 4th input gear bushing</li> <li>• Installing 5th input gear bushing</li> <li>• Installing 5th-6th synchronizer hub assembly</li> <li>• Installing 2nd main gear bushing</li> <li>• Installing 3rd main gear</li> </ul> <b>a: 46 mm (1.81 in) dia.</b> <b>b: 41 mm (1.61 in)</b>
ST30901000 (J-26010-01) Drift  ZZA0978D	<ul style="list-style-type: none"> <li>• Installing input shaft rear bearing</li> <li>• Installing 4th main gear</li> <li>• Installing 5th main gear</li> <li>• Installing 6th main gear</li> <li>• Installing mainshaft rear bearing</li> </ul> <b>a: 79 mm (3.11 in) dia.</b> <b>b: 45 mm (1.77 in) dia.</b> <b>c: 35.2 mm (1.386 in) dia.</b>
ST30032000 (J-26010-01) Drift  ZZA0978D	Installing input shaft front bearing <b>a: 80 mm (3.15 in) dia.</b> <b>b: 38 mm (1.50 in) dia.</b> <b>c: 31 mm (1.22 in) dia.</b>
ST38220000 ( — ) Press stand  ZZA1058D	<ul style="list-style-type: none"> <li>• Installing reverse main gear</li> <li>• Installing 1st main gear bushing</li> <li>• Installing 1st-2nd synchronizer hub assembly</li> </ul> <b>a: 63 mm (2.48 in) dia.</b> <b>b: 65 mm (2.56 in)</b>
KV40101630 (J-35870) Drift  ZZA1003D	Installing reverse main gear <b>a: 68 mm (2.68 in) dia.</b> <b>b: 60 mm (2.36 in) dia.</b>

A  
B  
MT  
D  
E  
F  
G  
H  
I  
J  
K  
L  
M  
N  
O  
P

# PREPARATION

< SERVICE INFORMATION >

[RS6F52A]

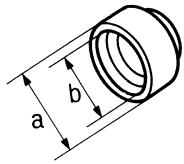
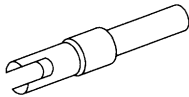
Tool number (Kent-Moore No.) Tool name	Description
KV38102510 ( — ) Drift	 <p style="text-align: right; margin-right: 50px;">ZZA0838D</p> <ul style="list-style-type: none"> <li>Installing 1st main gear bushing</li> <li>Installing 1st-2nd synchronizer hub assembly</li> <li>Installing differential side bearing (transaxle case side)</li> <li>Installing differential side bearing (clutch housing side)</li> </ul> <p><b>a: 71 mm (2.80 in) dia.</b>  <b>b: 65 mm (2.56 in) dia.</b></p>
(J-39713) Preload adapter	 <p style="text-align: right; margin-right: 50px;">NT087</p> <p>Measuring end play of side gear</p>

## Commercial Service Tool

INFOID:000000001850874

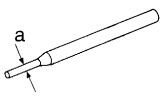
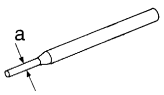
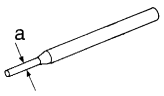
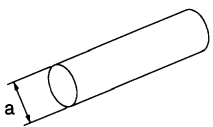
Tool name	Description
Pin punch	 <p style="text-align: right; margin-right: 50px;">NT410</p> <p>Removing and installing retaining pin  <b>a: 4.5 mm (0.177 in) dia.</b></p>
Pin punch	 <p style="text-align: right; margin-right: 50px;">NT410</p> <p>Removing and installing retaining pin of selector lever  <b>a: 5.5 mm (0.217 in) dia.</b></p>
Pin punch	 <p style="text-align: right; margin-right: 50px;">NT410</p> <p>Removing and installing retaining pin of each shifter lever  <b>a: 7.5 mm (0.295 in) dia.</b></p>
Drift	 <p style="text-align: right; margin-right: 50px;">S-NT063</p> <p>Installing striking rod oil seal and shifter lever oil seal  <b>a: 24.5 mm (0.965 in) dia.</b></p>



# PREPARATION

< SERVICE INFORMATION >

[RS6F52A]

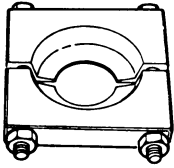
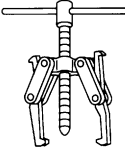
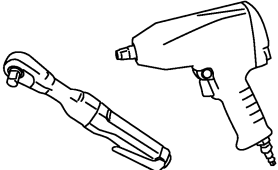
Tool name		Description
Puller  <div style="text-align: center;">   <small>ZZA0537D</small> </div>		Removing each bearing, gear, and bushing
Puller  <div style="text-align: center;">   <small>NT077</small> </div>		Removing each bearing, gear, and bushing
Power tool  <div style="text-align: center;">   <small>PBIC0190E</small> </div>		Loosening bolts and nuts

A  
B  
**MT**  
D  
E  
F  
G  
H  
I  
J  
K  
L  
M  
N  
O  
P

# NOISE, VIBRATION AND HARSHNESS (NVH) TROUBLESHOOTING

< SERVICE INFORMATION >

[RS6F52A]

## NOISE, VIBRATION AND HARSHNESS (NVH) TROUBLESHOOTING

### NVH Troubleshooting Chart

INFOID:000000001850875

Use the chart below to help you find the cause of the symptom. The numbers indicate the order of the inspection. If necessary, repair or replace these parts.

Reference page	<u>MT-61</u>			<u>MT-68</u>		<u>MT-64</u>		<u>MT-68</u>		<u>MT-68</u>		
SUSPECTED PARTS (Possible cause)	OIL (Oil level is low.)	OIL (Wrong oil.)	OIL (Oil level is high.)	GASKET (Damaged)	OIL SEAL (Worn or damaged)	SHIFT CONTROL LINKAGE (Worn)	STRIKING ROD ASSEMBLY (Worn or damaged)	SHIFT FORK (Worn)	GEAR (Worn or damaged)	BEARING (Worn or damaged)	BAULK RING (Worn or damaged)	INSERT SPRING (Damaged)
Symptoms	Noise	1	2						3	3		
	Oil leakage		3	1	2	2						
	Hard to shift or will not shift		1	1		2					3	3
	Jumps out of gear						1	2	3	3		

# DESCRIPTION

< SERVICE INFORMATION >

[RS6F52A]

## DESCRIPTION

### Cross-Sectional View

INFOID:000000001850876

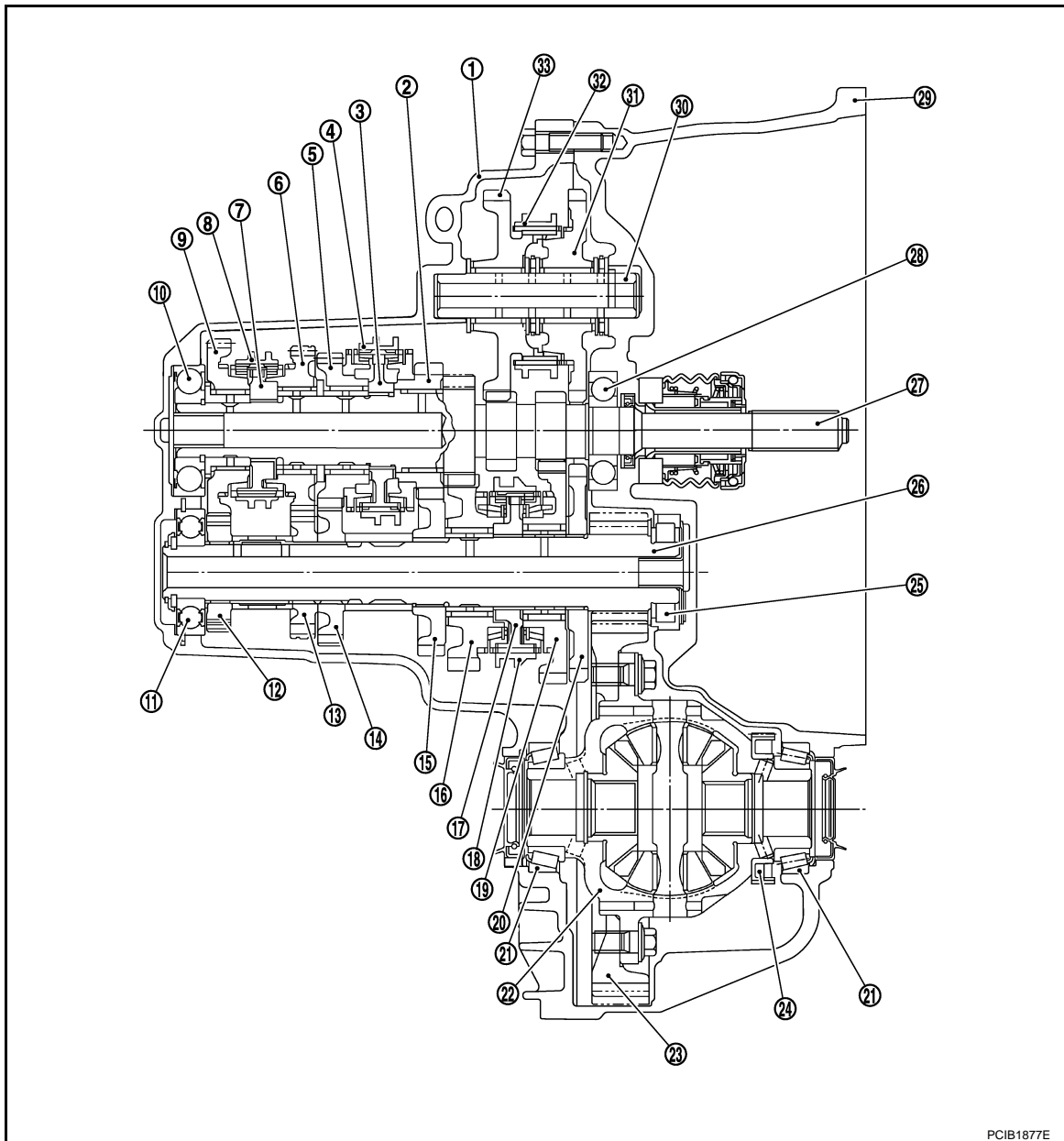

PCIB1877E

- |                                |                              |                               |
|--------------------------------|------------------------------|-------------------------------|
| 1. Transaxle case              | 2. 3rd input gear            | 3. 3rd-4th synchronizer hub   |
| 4. 3rd-4th coupling sleeve     | 5. 4th input gear            | 6. 5th input gear             |
| 7. 5th-6th synchronizer hub    | 8. 5th-6th coupling sleeve   | 9. 6th input gear             |
| 10. Input shaft rear bearing   | 11. Mainshaft rear bearing   | 12. 6th main gear             |
| 13. 5th main gear              | 14. 4th main gear            | 15. 3rd main gear             |
| 16. 2nd main gear              | 17. 1st-2nd synchronizer hub | 18. 1st-2nd coupling sleeve   |
| 19. 1st main gear              | 20. Reverse main gear        | 21. Differential side bearing |
| 22. Differential case assembly | 23. Final gear               | 24. Speedometer drive gear    |
| 25. Mainshaft front bearing    | 26. Mainshaft                | 27. Input shaft               |
| 28. Input shaft front bearing  | 29. Clutch housing           | 30. Reverse idler shaft       |
| 31. Reverse idler gear (front) | 32. Reverse coupling sleeve  | 33. Reverse idler gear (rear) |

### DOUBLE-CONE SYNCHRONIZER

MT-59

A

B

MT

D

E

F

G

H

I

J

K

L

M

N

O

P

# DESCRIPTION

< SERVICE INFORMATION >

[RS6F52A]

Double-cone synchronizer is adopted for 3rd gear to reduce operating force of the control lever.

## TRIPLE-CONE SYNCHRONIZER

Triple-cone synchronizer are adopted for 1st and 2nd gears to reduce operating force of the control lever.

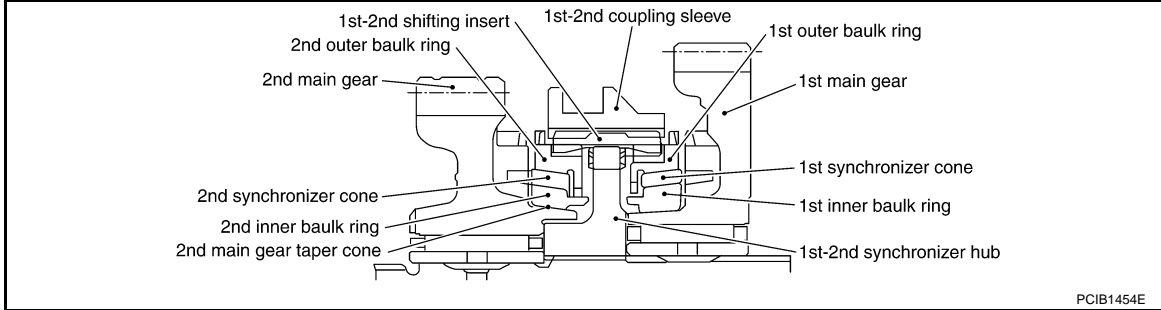

## REVERSE GEAR NOISE PREVENTION FUNCTION (SYNCHRONIZING METHOD)

Reverse gear can be matched smoothly in a structure by setting synchronizer hub (1) of reverse idler gear (rear), reverse coupling sleeve (2), reverse baulk ring (3), and reverse insert spring (4) to reverse idler gears, and letting reverse gear be synchronized.

- 5 : Reverse idler gear (rear)
- 6 : Reverse idler gear (front)

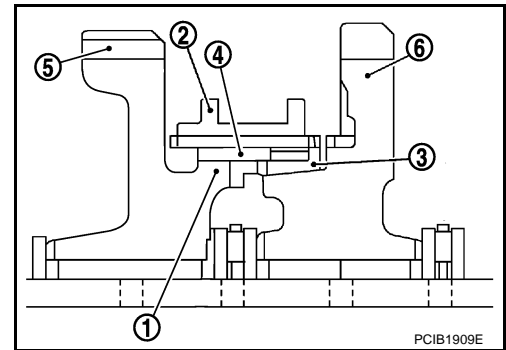

M/T OIL

Changing M/T Oil

INFOID:000000001850877

DRAINING

1. Start engine and let it run to warm up transaxle.
2. Stop engine. Remove transaxle drain plug and drain oil.
3. Set a gasket on drain plug and install it to transaxle. Tighten drain plug to the specified torque. Refer to [MT-68, "Disassembly and Assembly"](#).  
**CAUTION:**  
**Do not reuse gasket.**

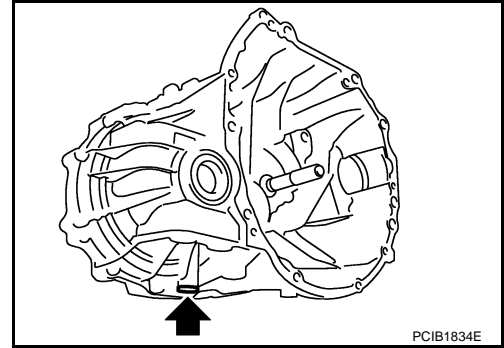

FILLING

1. Remove plug (with ABS models) (1) or speedometer pinion gear (without ABS models) (1). Fill the transaxle with new oil and check the oil level "L" using suitable gauge (A) as shown.

**Oil grade and capacity** : Refer to [MA-13, "QR25DE"](#).

**Oil level "L"** : 61.0 - 67.0 mm (2.402 - 2.638 in)

2. Set an O-ring on plug (with ABS models) (1) or speedometer pinion gear (without ABS models) (1) and then install it to transaxle. Tighten to the specified torque. Refer to [MT-68, "Disassembly and Assembly"](#).

**CAUTION:**  
**Do not reuse O-ring.**

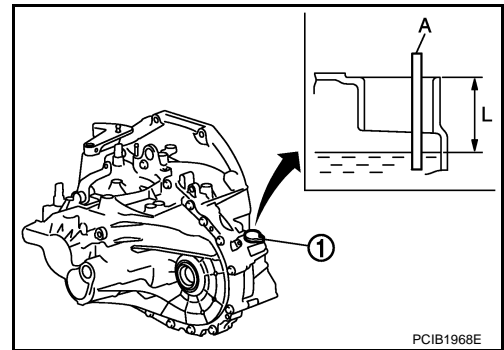

Checking M/T Oil

INFOID:000000001850878

OIL LEAKAGE AND OIL LEVEL

1. Make sure that oil is not leaking from transaxle or around it.
2. Remove plug (with ABS models) (1) or speedometer pinion gear (without ABS models) (1).
3. Check the oil level "L" using suitable gauge (A) as shown.

**Oil level "L"** : 61.0 - 67.0 mm (2.402 - 2.638 in)

**CAUTION:**  
**Do not start engine while checking oil level.**

4. Set an O-ring on plug (with ABS models) (1) or speedometer pinion gear (without ABS models) (1) and then install it to transaxle. Tighten to the specified torque. Refer to [MT-68, "Disassembly and Assembly"](#).

**CAUTION:**  
**Do not reuse O-ring.**

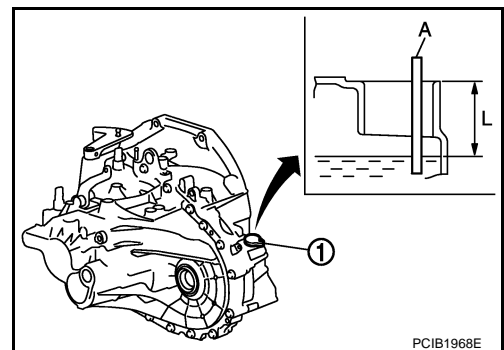

A  
B  
C  
D  
E  
F  
G  
H  
I  
J  
K  
L  
M  
N  
O  
P

# SIDE OIL SEAL

< SERVICE INFORMATION >

[RS6F52A]

## SIDE OIL SEAL

### Removal and Installation

INFOID:000000001850879

#### REMOVAL

1. Remove front drive shafts from transaxle assembly. Refer to [FAX-8, "Removal and Installation \(Left Side\)"](#) and [FAX-10, "Removal and Installation \(Right Side\)"](#).

2. Remove differential side oil seal (1) using a suitable tool.

**CAUTION:**

**Do not damage transaxle case and clutch housing.**

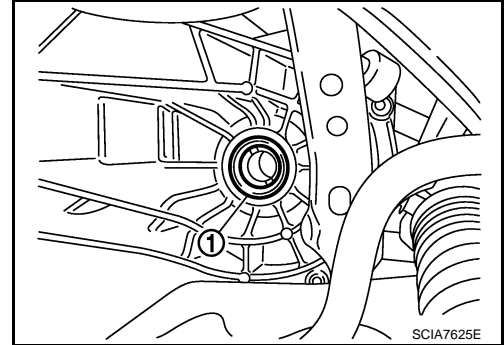

#### INSTALLATION

Installation is in the reverse order of removal.

- Install differential side oil seal to clutch housing and transaxle case to the specified dimension "A" using Tools.

**Dimension "A"** : -0.5 - 0.5 mm (-0.020 - 0.020 in)

**Tool numbers** : ST30720000 (J-25405)

: ST33400001 (J-26082)

**CAUTION:**

**Do not reuse oil seal.**

- Check oil level after installation. Refer to [MT-61, "Checking M/T Oil"](#).

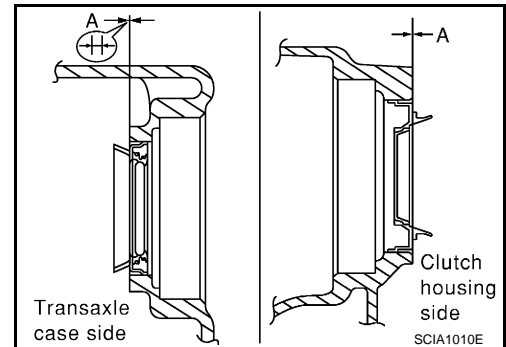

# POSITION SWITCH

[RS6F52A]

< SERVICE INFORMATION >

## POSITION SWITCH

### Checking

INFOID:000000001850880

#### NOTE:

For removal and installation of the switches, refer to [MT-68. "Disassembly and Assembly"](#).

#### BACK-UP LAMP SWITCH

- Check continuity.

Gear position	Continuity
Reverse	Yes
Except reverse	No

1 : Park/Neutral position (PNP) switch

2 : Back-up lamp switch

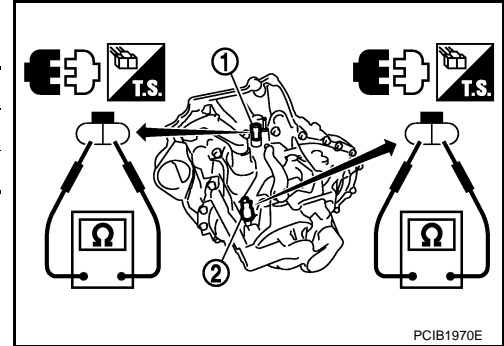

#### PARK/NEUTRAL POSITION (PNP) SWITCH

- Check continuity.

Gear position	Continuity
Neutral	Yes
Except neutral	No

A  
B  
MT  
D  
E  
F  
G  
H  
I  
J  
K  
L  
M  
N  
O  
P

# CONTROL LINKAGE

< SERVICE INFORMATION >

[RS6F52A]

## CONTROL LINKAGE

### Component of Control Device and Cable

INFOID:000000001850881

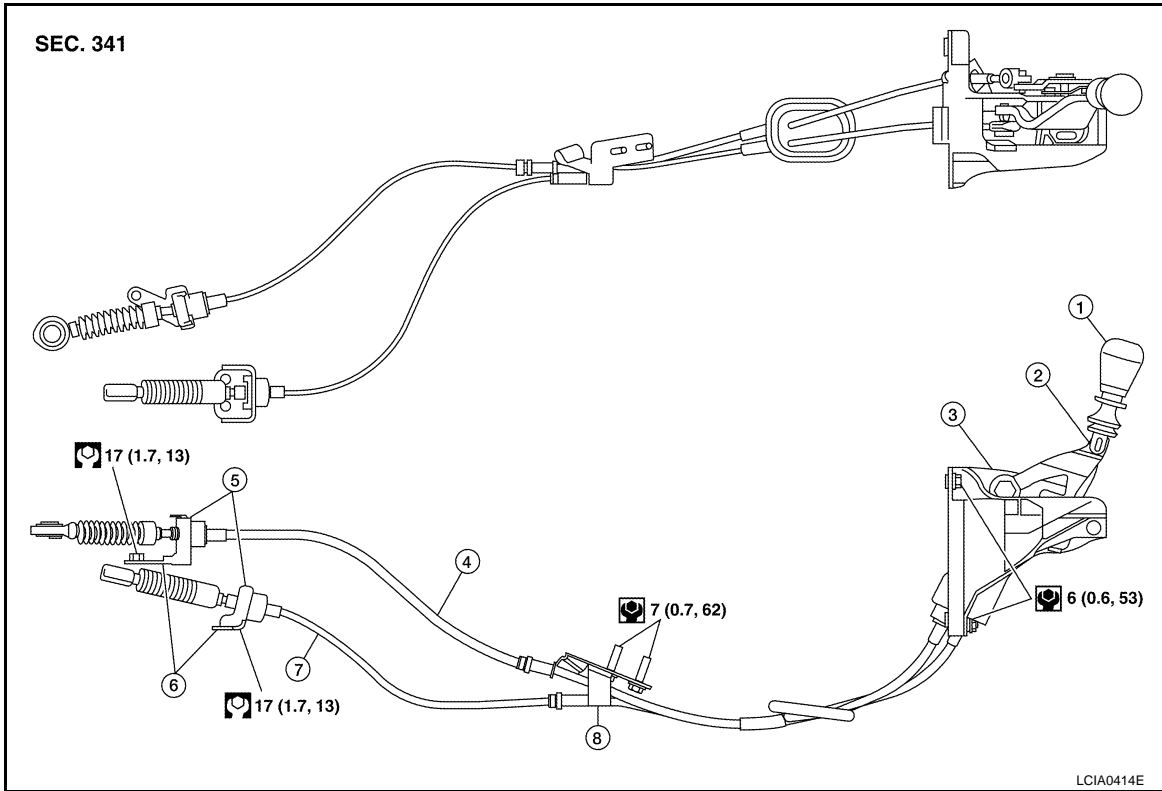

- |                       |                          |                            |
|-----------------------|--------------------------|----------------------------|
| 1. Control lever knob | 2. Control lever         | 3. Control device assembly |
| 4. Select cable       | 5. Lock plate            | 6. Cable bracket           |
| 7. Shift cable        | 8. Cable support bracket |                            |

### Removal and Installation

INFOID:000000001850882

#### REMOVAL

1. Remove battery. Refer to [SC-7, "Removal and Installation QR25DE"](#).
2. Remove air cleaner and air duct. Refer to [EM-127, "Removal and Installation"](#).
3. Remove shift cable from shifter lever as shown.

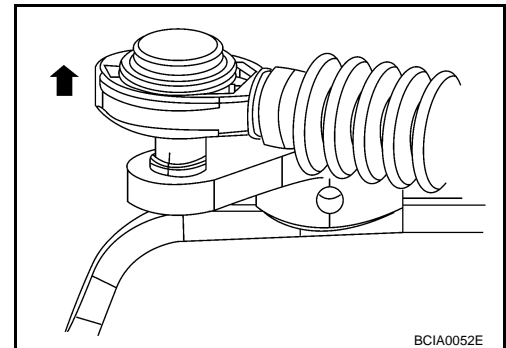



# CONTROL LINKAGE

[RS6F52A]

## < SERVICE INFORMATION >

4. Remove select cable from selector lever A as shown.

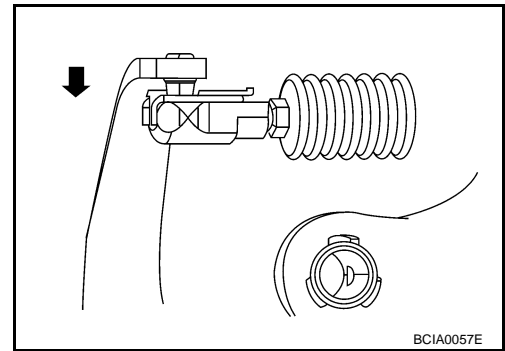

5. Shift control lever to neutral position.
6. Remove control lever knob.
7. Remove center console assembly. Refer to [IP-11, "Removal and Installation"](#).
8. Remove control device assembly nuts.
9. Remove exhaust front tube, center muffler and heat shield. Refer to [EX-6, "Removal and Installation"](#).
10. Remove cable support bracket.
11. Remove select cable and shift cable from cable bracket.
12. Remove control device assembly from the vehicle.

## INSTALLATION

Installation is in the reverse order of removal.

- Securely install each cable to shifter lever and selector lever.
- Be careful about the installation direction, and screw control lever knob onto control lever.

⇐: Front

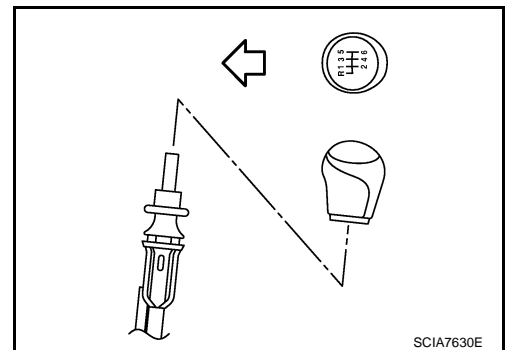

- When control lever is selected to 1st-2nd side and 5th-6th side, confirm control lever returns to neutral position smoothly.
- When control lever is shifted to each position, make sure there is no binding or disconnection in each boot.

# AIR BREATHER HOSE

< SERVICE INFORMATION >

[RS6F52A]

## AIR BREATHER HOSE

### Removal and Installation

INFOID:000000001850883

Refer to the figure for air breather hose removal and installation information.

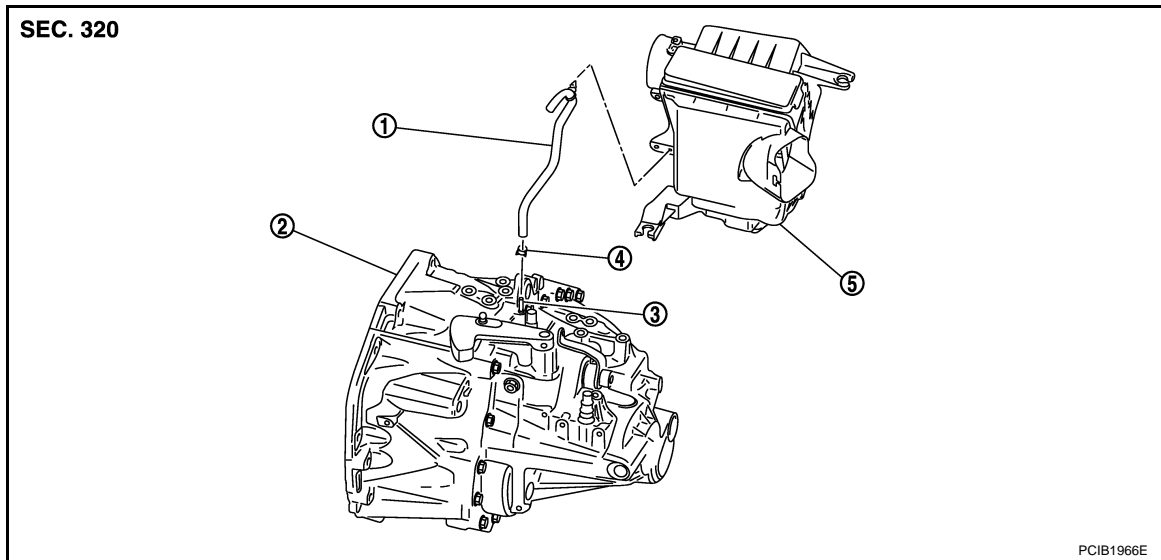

- |                      |                       |                      |
|----------------------|-----------------------|----------------------|
| 1. Air breather hose | 2. Transaxle assembly | 3. Air breather tube |
| 4. Clamp             | 5. Air cleaner case   |                      |

#### **CAUTION:**

- Make sure there are no pinched or restricted areas on the air breather hose caused by bending or winding when installing it.
- Be sure to insert air breather hose into air breather tube until hose end reaches the tube's base.
- Set air breather hose with painted mark facing forward.
- Install air breather hose to air cleaner case by fully inserting the clip.

# TRANSAXLE ASSEMBLY

< SERVICE INFORMATION >

[RS6F52A]

## TRANSAXLE ASSEMBLY

### Component

INFOID:000000001850884

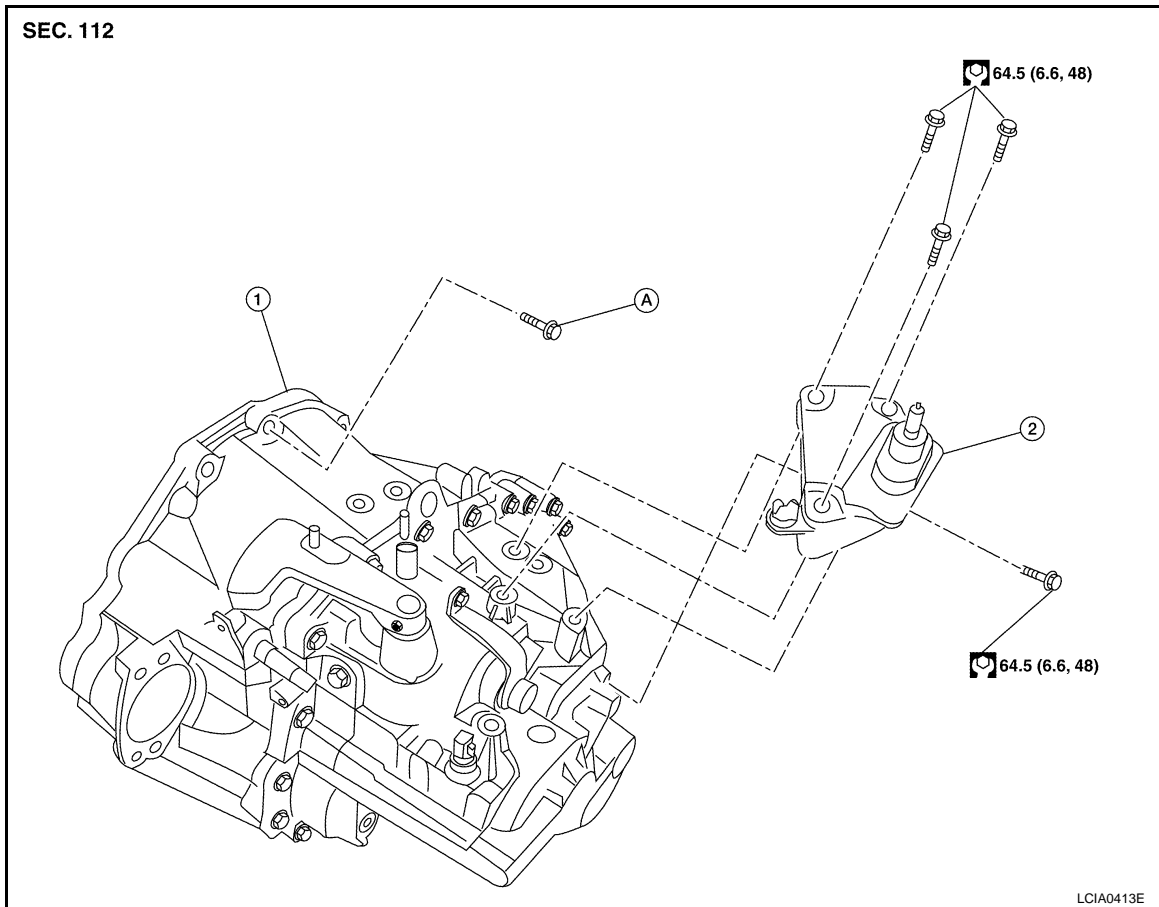

1. Transaxle assembly
2. LH engine mount bracket
- A. Refer to [MT-67, "Removal and Installation"](#).

### Removal and Installation

INFOID:000000001850885

#### CAUTION:

If transaxle assembly is removed from the vehicle, always replace CSC (Concentric Slave Cylinder). Inserted CSC returns to the original position when removing transaxle assembly. Dust on clutch disc sliding parts may damage CSC seal, and may cause clutch fluid leakage.

#### REMOVAL

1. Drain gear oil. Refer to [MT-61, "Changing M/T Oil"](#).
2. Drain clutch fluid and remove clutch tube from CSC. Refer to [CL-12, "Removal and Installation"](#).

#### CAUTION:

Never depress clutch pedal during removal procedure.

3. Remove engine and transaxle assembly. Refer to [EM-177, "Removal and Installation"](#).
4. Remove starter motor. Refer to [SC-21, "Removal and Installation QR25DE"](#).
5. Remove transaxle assembly to engine bolts.
6. Separate transaxle assembly from engine.

#### INSTALLATION

Installation is in the reverse order of removal.

- If transaxle assembly is removed from the vehicle, always replace CSC. Refer to [CL-11, "Removal and Installation"](#).

# TRANSAXLE ASSEMBLY

[RS6F52A]

## < SERVICE INFORMATION >

- When installing the transaxle assembly to the engine, use the specified tightening torque in the numerical sequence shown:

- : Transaxle to engine
- X : Engine to transaxle

**CAUTION:**

**When installing transaxle assembly, never allow the transaxle input shaft to make contact with the clutch cover.**

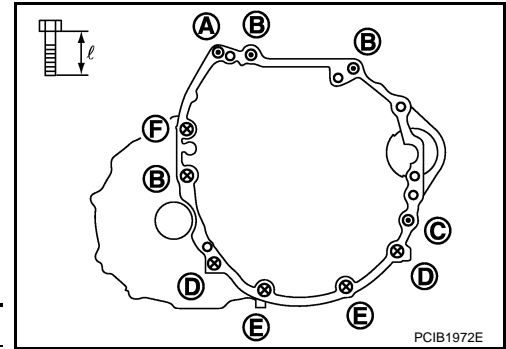

Bolt symbol	A	B	C	D	E	F
Quantity	1	3	1	2	2	1
Bolt length "ℓ" mm (in)	45 (1.77)		80 (3.15)	45 (1.77)	35 (1.38)	45 (1.77)
Tightening torque N·m (kg·m, ft·lb)	35.3 (3.6, 26)		74.5 (7.6, 55)		42.6 (4.3, 31)	
					48.0 (4.9, 35)	

- Bleed the air from the clutch hydraulic system. Refer to [CL-8. "Air Bleeding Procedure"](#).
- After installation, check oil level and check for leaks and loose mechanisms. Refer to [MT-61. "Checking M/T Oil"](#).

## Disassembly and Assembly

INFOID:000000001850886

### COMPONENTS

#### Case and Housing Components

# TRANSAXLE ASSEMBLY

< SERVICE INFORMATION >

[RS6F52A]

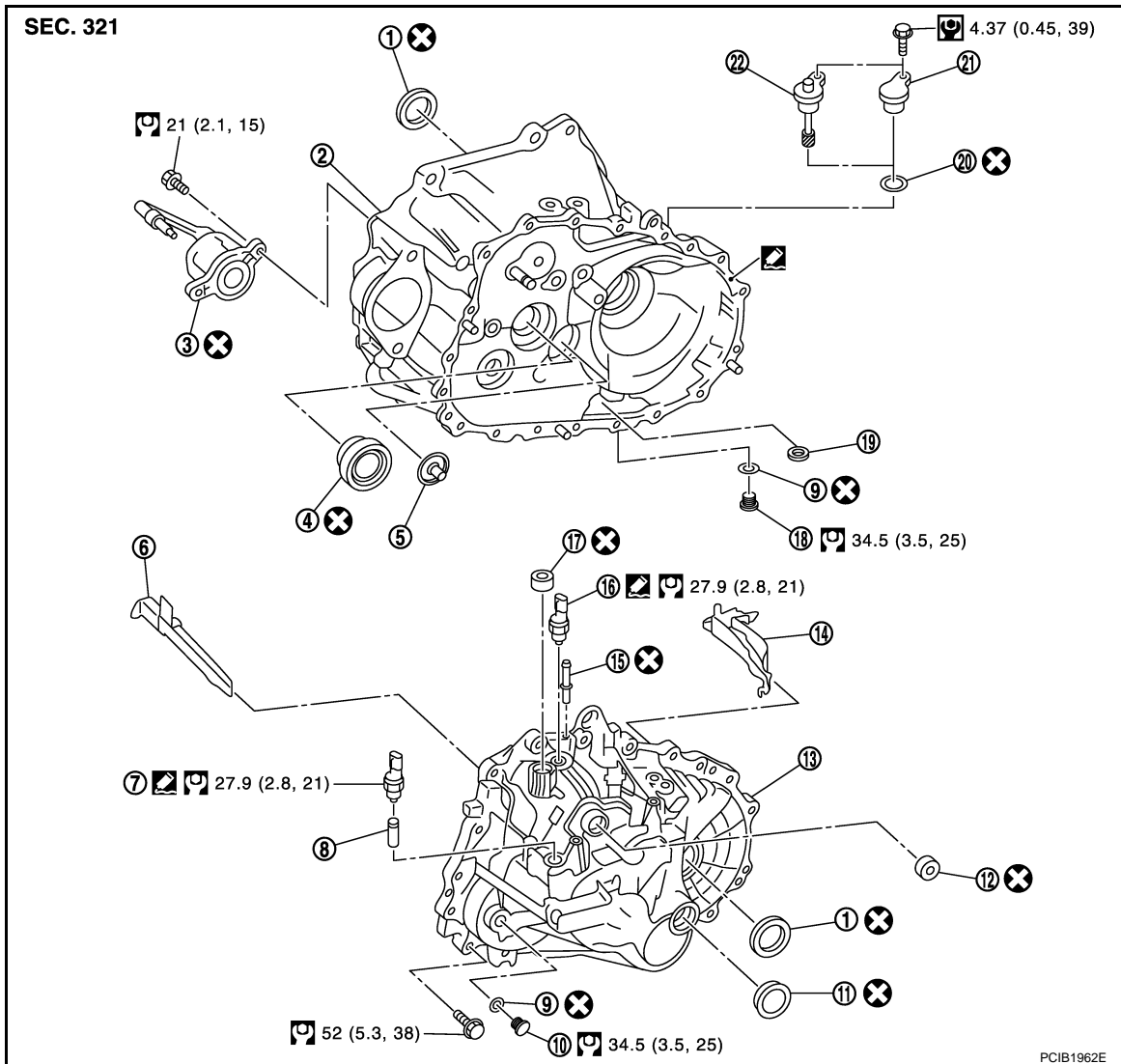

- |  |                            |                                    |
|--|----------------------------|------------------------------------|
| 1. Differential side oil seal                    | 2. Clutch housing          | 3. CSC (Concentric Slave Cylinder) |
| 4. Input shaft oil seal                          | 5. Oil channel             | 6. Oil gutter A                    |
| 7. Back-up lamp switch                           | 8. Plunger                 | 9. Gasket                          |
| 10. Plug   | 11. Bore plug              | 12. Striking rod oil seal          |
| 13. Transaxle case                               | 14. Oil gutter B           | 15. Air breather tube              |
| 16. Park/Neutral position (PNP) switch           | 17. Shifter lever oil seal | 18. Drain plug                     |
| 19. Magnet                                       | 20. O-ring                 | 21. Plug (With ABS models)         |
| 22. Speedometer pinion gear (Without ABS models) |                            |                                    |

: Apply Genuine Silicone RTV or an equivalent. Refer to [GI-42, "Recommended Chemical Product and Sealant"](#).

Gear Components

A  
B  
MT  
D  
E  
F  
G  
H  
I  
J  
K  
L  
M  
N  
O  
P

# TRANSAXLE ASSEMBLY

< SERVICE INFORMATION >

[RS6F52A]

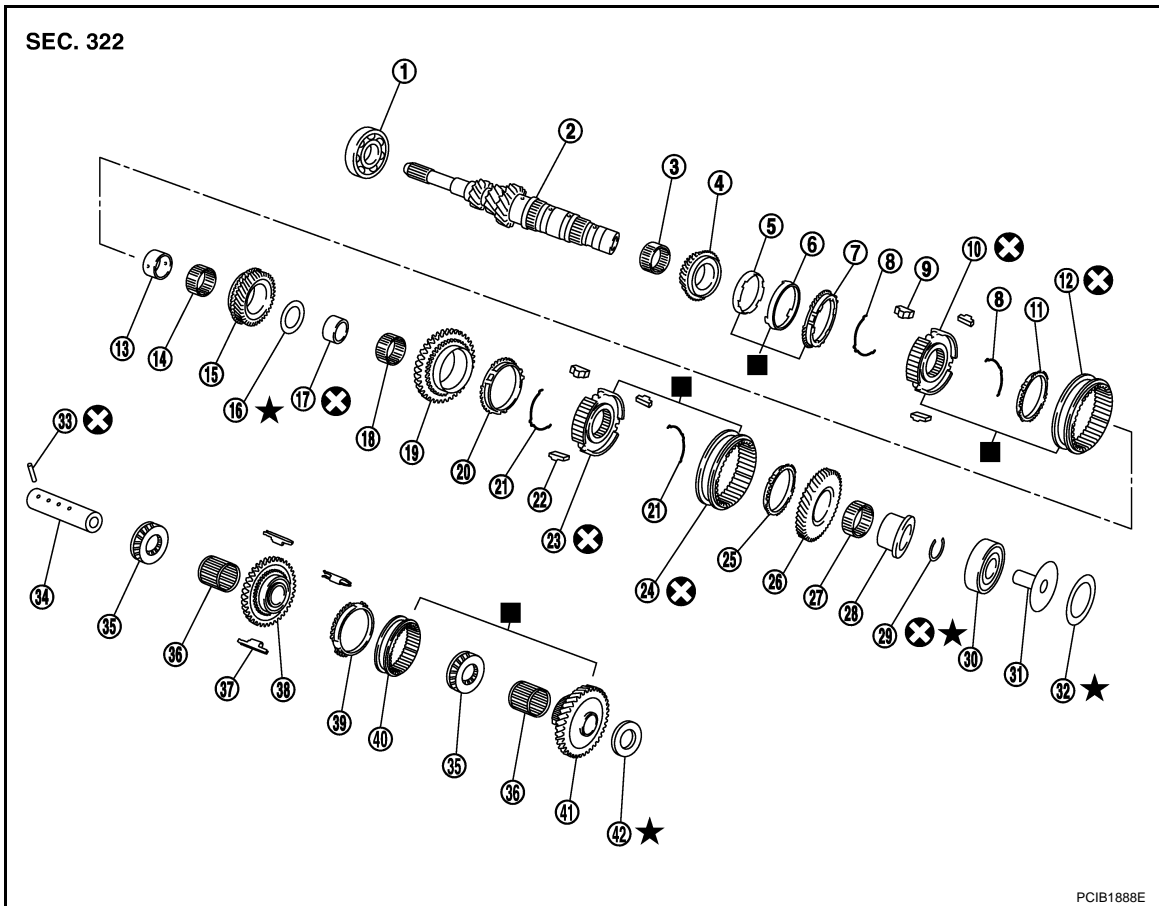

- |                              |   |                                       |
|------------------------------|---|---------------------------------------|
| 1. Input shaft front bearing | 2. Input shaft                              | 3. 3rd needle bearing                 |
| 4. 3rd input gear            | 5. 3rd inner baulk ring                     | 6. 3rd synchronizer cone              |
| 7. 3rd outer baulk ring      | 8. 3rd-4th spread spring                    | 9. 3rd-4th shifting insert            |
| 10. 3rd-4th synchronizer hub | 11. 4th baulk ring                          | 12. 3rd-4th coupling sleeve           |
| 13. 4th input gear bushing   | 14. 4th needle bearing                      | 15. 4th input gear                    |
| 16. Thrust washer            | 17. 5th input gear bushing                  | 18. 5th needle bearing                |
| 19. 5th input gear           | 20. 5th baulk ring                          | 21. 5th-6th spread spring             |
| 22. 5th-6th shifting insert  | 23. 5th-6th synchronizer hub                | 24. 5th-6th coupling sleeve           |
| 25. 6th baulk ring           | 26. 6th input gear                          | 27. 6th needle bearing                |
| 28. 6th input gear bushing   | 29. Snap ring                               | 30. Input shaft rear bearing          |
| 31. Oil channel              | 32. Input shaft rear bearing adjusting shim | 33. Retaining pin                     |
| 34. Reverse idler shaft      | 35. Thrust needle bearing                   | 36. Reverse idler gear needle bearing |
| 37. Reverse insert spring    | 38. Reverse idler gear (front)              | 39. Reverse baulk ring                |
| 40. Reverse coupling sleeve  | 41. Reverse idler gear (rear)               | 42. Reverse idler gear adjusting shim |

■: Replace the parts as a set.

Refer to [GI-8. "Component"](#) for symbols not described.

- Apply gear oil to gears, shafts, synchronizers, and bearings during assembly.

# TRANSAXLE ASSEMBLY

< SERVICE INFORMATION >

[RS6F52A]

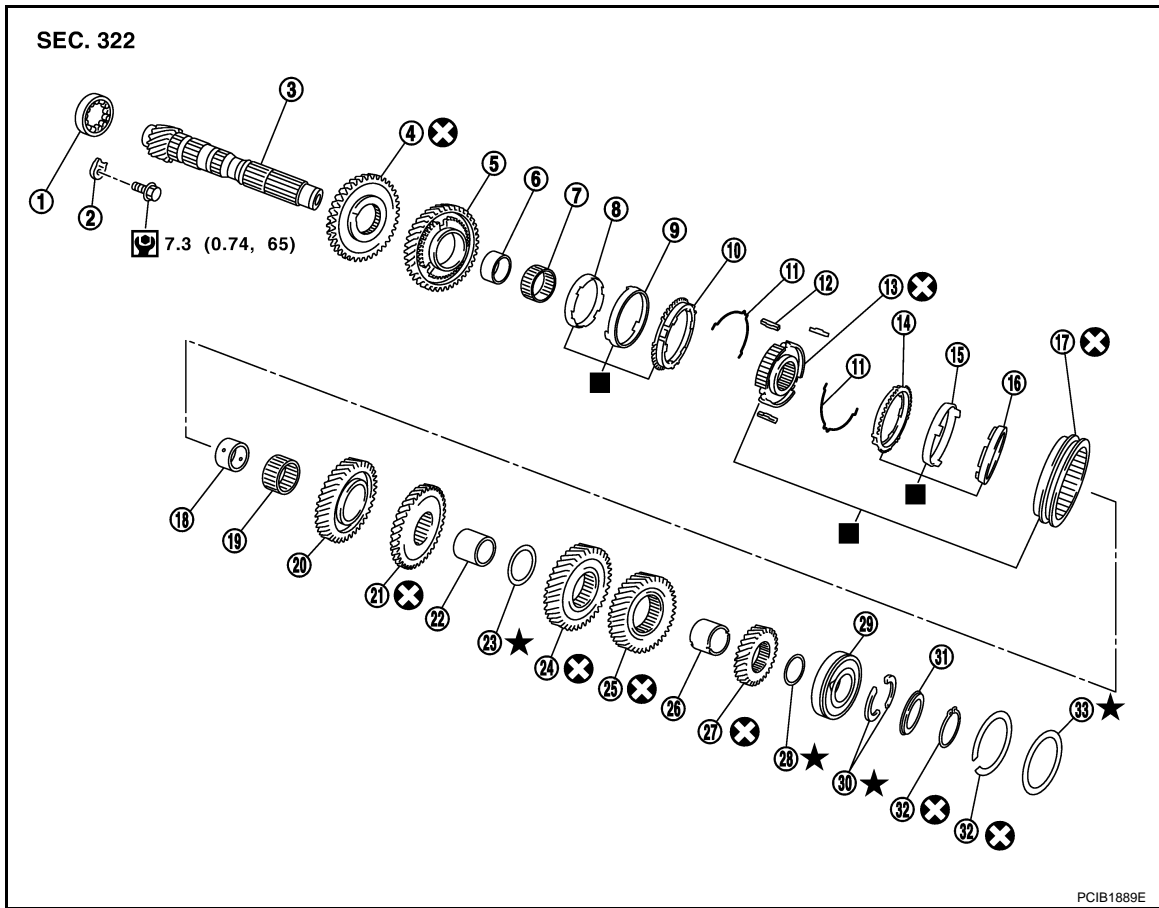

- |                                  |                                  |   |
|----------------------------------|----------------------------------|---|
| 1. Mainshaft front bearing       | 2. Mainshaft bearing retainer    | 3. Mainshaft                              |
| 4. Reverse main gear             | 5. 1st main gear                 | 6. 1st main gear bushing                  |
| 7. 1st needle bearing            | 8. 1st inner baulk ring          | 9. 1st synchronizer cone                  |
| 10. 1st outer baulk ring         | 11. 1st-2nd spread spring        | 12. 1st-2nd shifting insert               |
| 13. 1st-2nd synchronizer hub     | 14. 2nd outer baulk ring         | 15. 2nd synchronizer cone                 |
| 16. 2nd inner baulk ring         | 17. 1st-2nd coupling sleeve      | 18. 2nd main gear bushing                 |
| 19. 2nd needle bearing           | 20. 2nd main gear                | 21. 3rd main gear                         |
| 22. 3rd-4th mainshaft spacer     | 23. 4th main gear adjusting shim | 24. 4th main gear                         |
| 25. 5th main gear                | 26. 5th-6th mainshaft spacer     | 27. 6th main gear                         |
| 28. 6th main gear adjusting shim | 29. Mainshaft rear bearing       | 30. Mainshaft C-ring                      |
| 31. C-ring holder                | 32. Snap ring                    | 33. Mainshaft rear bearing adjusting shim |

■: Replace the parts as a set.

Refer to [GI-8, "Component"](#) for symbols not described.

- Apply gear oil to gears, shafts, synchronizers, and bearings during assembly.

Shift Control Components

A  
B  
MT  
D  
E  
F  
G  
H  
I  
J  
K  
L  
M  
N  
O  
P

# TRANSAXLE ASSEMBLY

< SERVICE INFORMATION >

[RS6F52A]

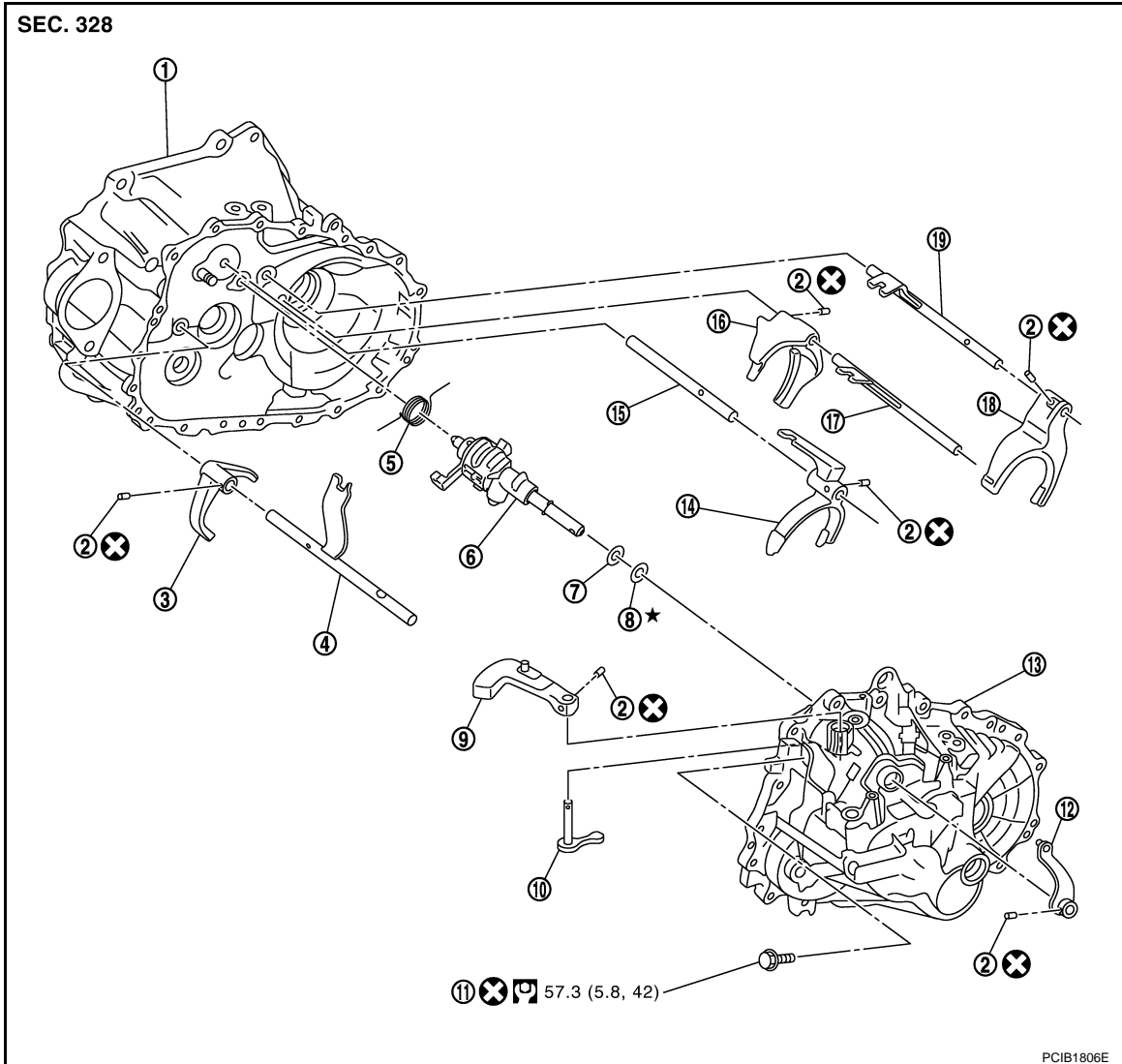

- |                        |                                |                          |
|------------------------|--------------------------------|--------------------------|
| 1. Clutch housing      | 2. Retaining pin               | 3. Reverse shift fork    |
| 4. Reverse fork rod    | 5. Return spring               | 6. Striking rod assembly |
| 7. Striking rod shim   | 8. Striking rod adjusting shim | 9. Shifter lever A       |
| 10. Shifter lever B    | 11. Guide bolt                 | 12. Selector lever       |
| 13. Transaxle case     | 14. 3rd-4th shift fork         | 15. 3rd-4th fork rod     |
| 16. 1st-2nd shift fork | 17. 1st-2nd fork rod           | 18. 5th-6th shift fork   |
| 19. 5th-6th fork rod   |                                |                          |

Refer to [GI-8, "Component"](#) for symbols not described.

Final Drive Components



# TRANSAXLE ASSEMBLY

< SERVICE INFORMATION >

[RS6F52A]

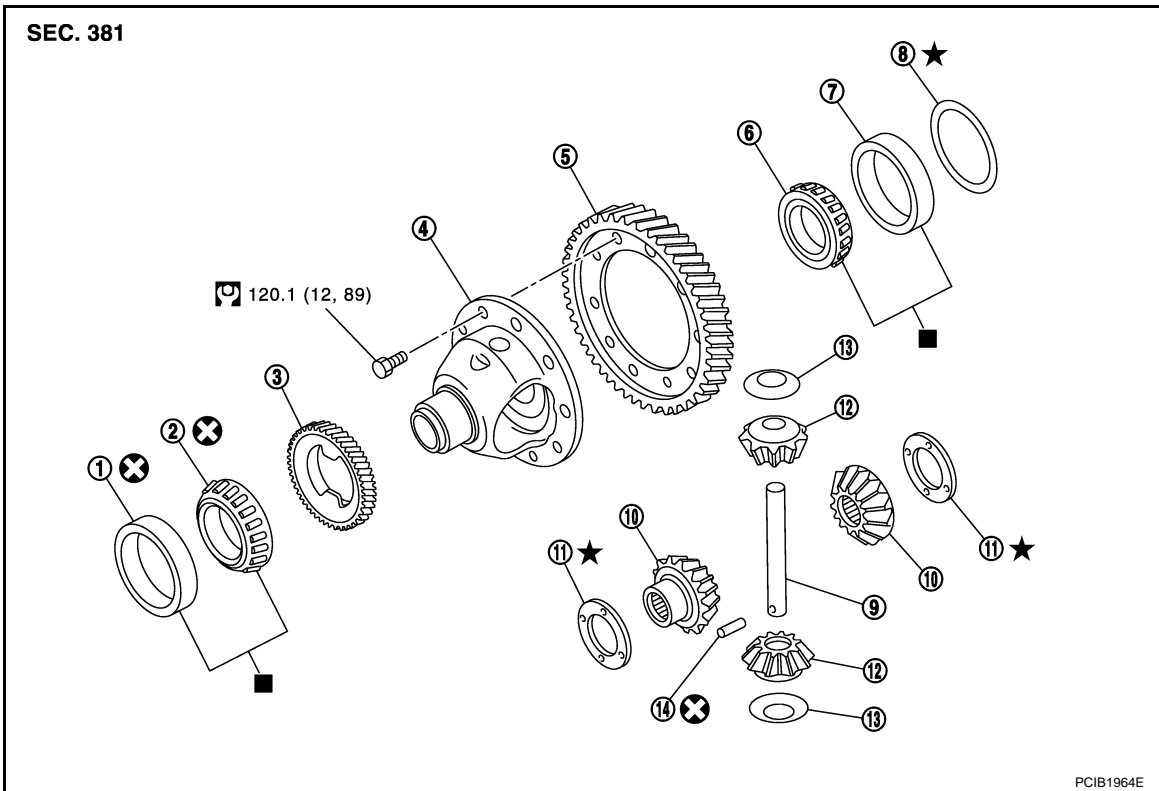

- |   |  |  |
|---|--|--|
| 1. Differential side bearing outer race (clutch housing side) | 2. Differential side bearing (clutch housing side) | 3. Speedometer drive gear                          |
| 4. Differential case  | 5. Final gear                                      | 6. Differential side bearing (transaxle case side) |
| 7. Differential side bearing outer race (transaxle case side) | 8. Differential side bearing adjusting shim        | 9. Pinion mate shaft                               |
| 10. Side gear   | 11. Side gear thrust washer                        | 12. Pinion mate gear                               |
| 13. Pinion mate thrust washer                                 | 14. Retaining pin                                  |  |

■: Replace the parts as a set.

Refer to [GI-8, "Component"](#) for symbols not described.

## DISASSEMBLY

1. Remove drain plug and gasket from clutch housing.

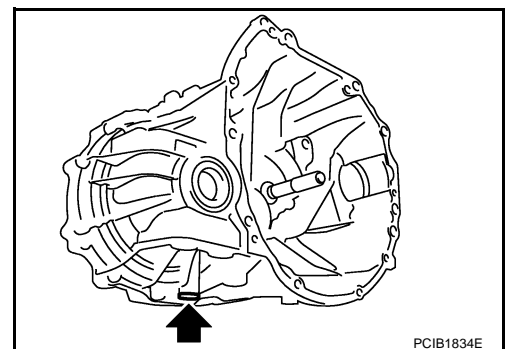

A  
B  
MT  
D  
E  
F  
G  
H  
I  
J  
K  
L  
M  
N  
O  
P

# TRANSAXLE ASSEMBLY

[RS6F52A]

## < SERVICE INFORMATION >

2. Remove plug bolt and then plug (with ABS models) or speedometer pinion gear (without ABS models) and O-ring from clutch housing.

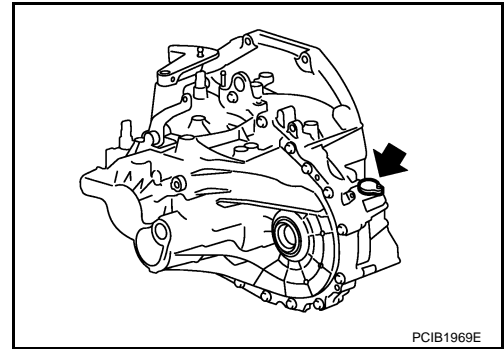

3. Remove plug and gasket from transaxle case.

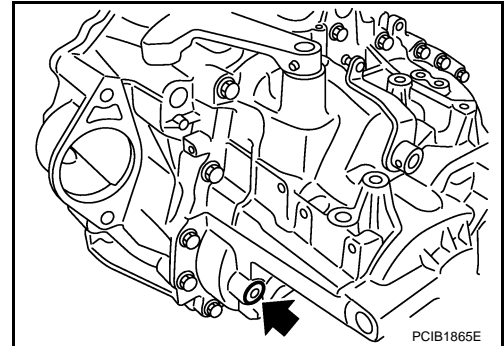

4. Remove park/neutral position (PNP) switch (1) from transaxle case.

5. Remove back-up lamp switch (2) and plunger from transaxle case.

**CAUTION:**

**Do not lose plunger.**

6. Remove air breather tube (3) from transaxle case.

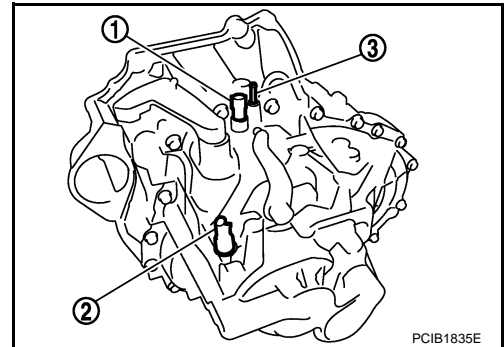

7. Remove guide bolt from transaxle case.

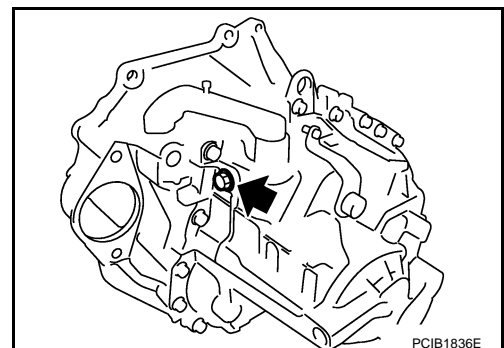

8. Remove retaining pin using suitable tool and then remove selector lever from transaxle case.

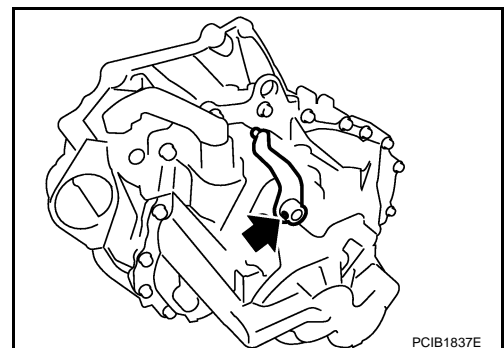

# TRANSAXLE ASSEMBLY

[RS6F52A]

< SERVICE INFORMATION >

9. Remove transaxle case bolts.

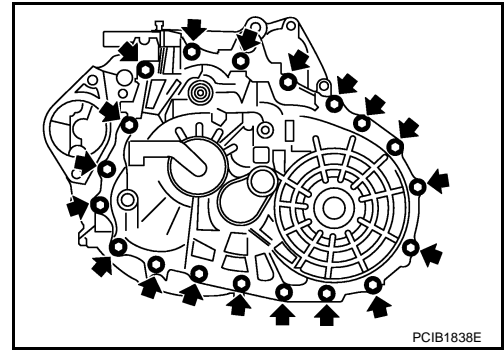

10. Remove bore plug from transaxle case using suitable tool.

**CAUTION:**

- Do not damage transaxle case.
- Access bore plug from cutout (A) of transaxle case when removing.

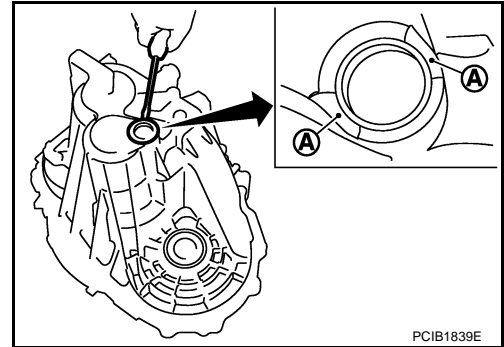

11. Remove transaxle case following the procedures below.

a. Expand snap ring at mainshaft rear bearing accessing from the bore plug hole. Then pull up transaxle case from clutch housing until snap ring comes off.

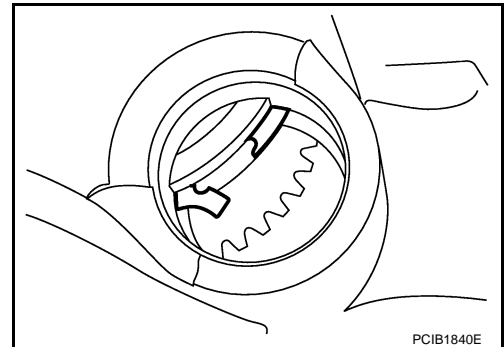

b. With shifter lever A (1) held in the position shown, remove transaxle case from clutch housing.

**CAUTION:**

**Do not drop adjusting shims.**

**NOTE:**

Make sure to hold shifter lever A in the position shown. Otherwise transaxle case cannot be removed from clutch housing.

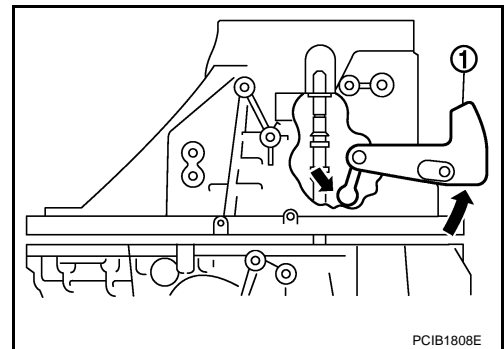

A  
B  
MT  
D  
E  
F  
G  
H  
I  
J  
K  
L  
M  
N  
O  
P

# TRANSAXLE ASSEMBLY

[RS6F52A]

## < SERVICE INFORMATION >

12. Remove oil gutter A (1) and oil gutter B (2) from transaxle case.

A : Tab of oil gutter

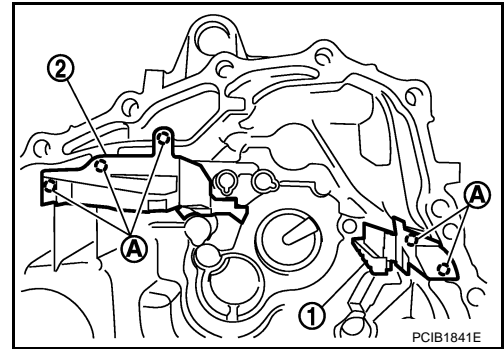

13. Remove snap ring from transaxle case.

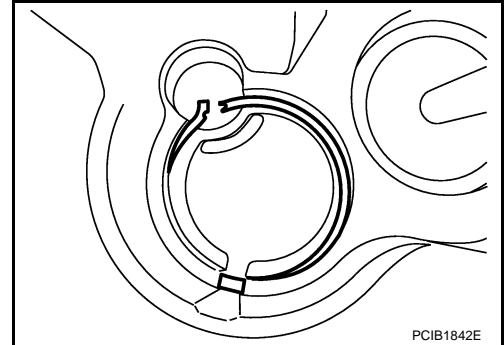

14. Remove retaining pin using suitable tool and then remove shifter lever A and shifter lever B from transaxle case.

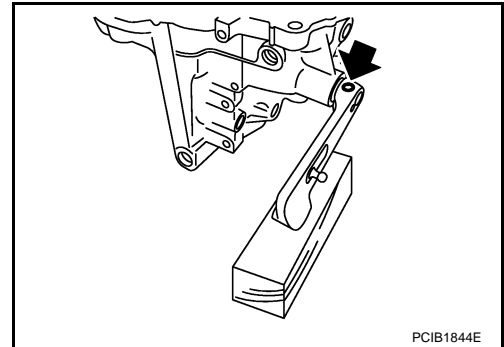

15. Remove differential side bearing outer race (transaxle case side) from transaxle case using Tool. Then remove differential side bearing adjusting shim from transaxle case.

**CAUTION:**

**Do not damage transaxle case or differential side bearing outer race.**

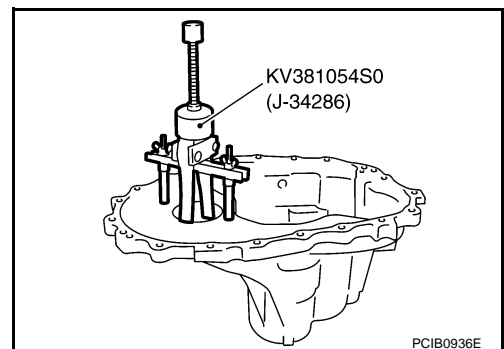

16. Remove differential side oil seal from transaxle case using suitable tool.

**CAUTION:**

**Do not damage transaxle case.**

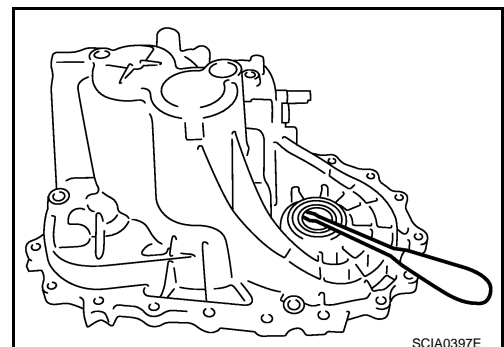

# TRANSAXLE ASSEMBLY

[RS6F52A]

< SERVICE INFORMATION >

17. Remove shifter lever oil seal (1) and striking rod oil seal (2) from transaxle case.

**CAUTION:**

**Do not damage transaxle case.**

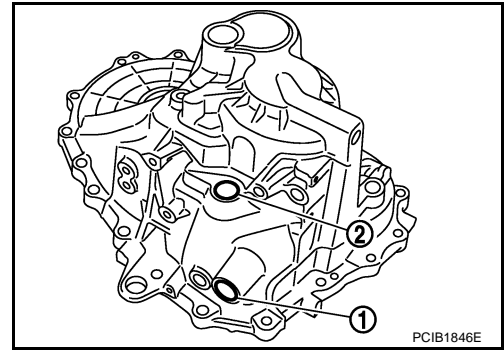

18. Remove striking rod shim (1), striking rod adjusting shim (2), mainshaft rear bearing adjusting shim (3), input shaft rear bearing adjusting shim (4), and reverse idler gear adjusting shim (5).

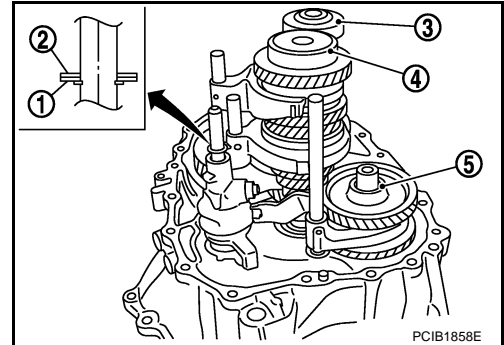

19. Remove retaining pin of reverse shift fork (1) using suitable tool.

2 : Reverse fork rod

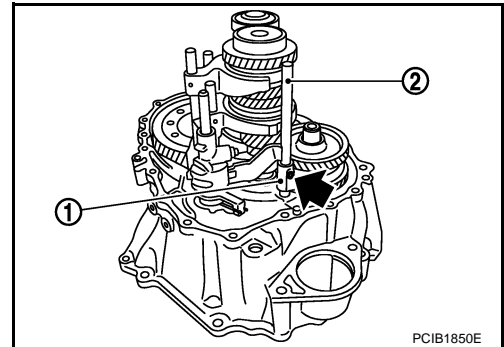

20. Rotate striking lever of striking rod assembly as shown. Then rotate reverse fork rod to a position where bracket of reverse fork rod does not interfere with striking lever of striking rod assembly.

21. Pull out reverse shift fork and reverse fork rod.

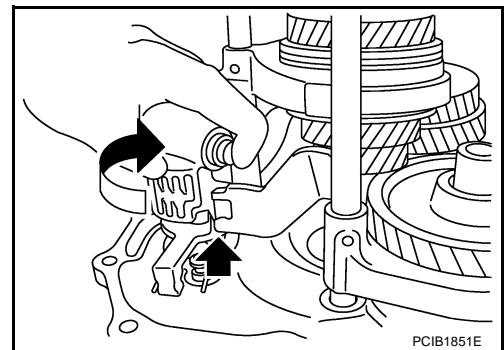

22. Remove retaining pin of 5th-6th shift fork (1) using suitable tool.

2 : 5th-6th fork rod

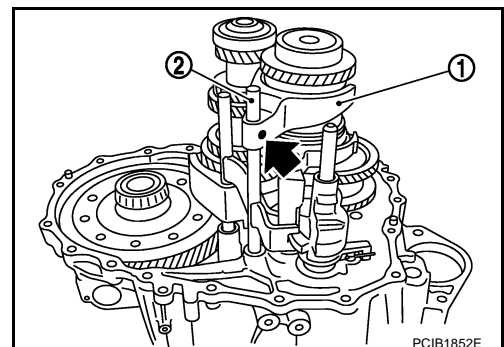

A  
B  
MT  
D  
E  
F  
G  
H  
I  
J  
K  
L  
M  
N  
O  
P

# TRANSAXLE ASSEMBLY

[RS6F52A]

< SERVICE INFORMATION >

23. Remove retaining pin of 3rd-4th shift fork (1) using a suitable tool.

24. Pull out 3rd-4th fork rod (2).

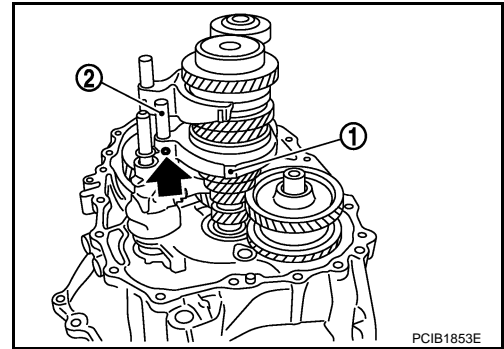

25. Pull out 5th-6th shift fork (1) and 5th-6th fork rod (2).

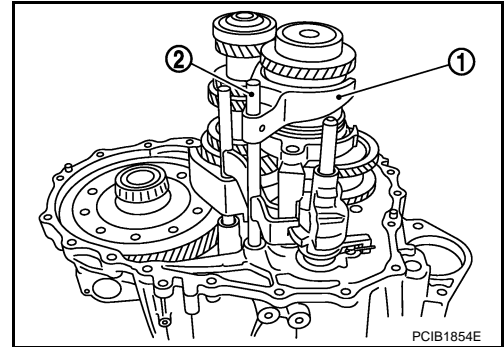

26. Pull out 3rd-4th shift fork (1).

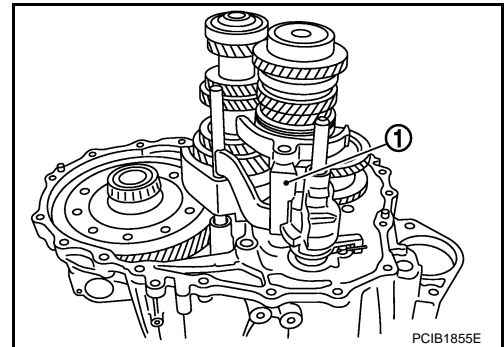

27. Remove retaining pin of 1st-2nd shift fork (1) using suitable tool.

28. Pull out 1st-2nd shift fork and 1st-2nd fork rod (2).

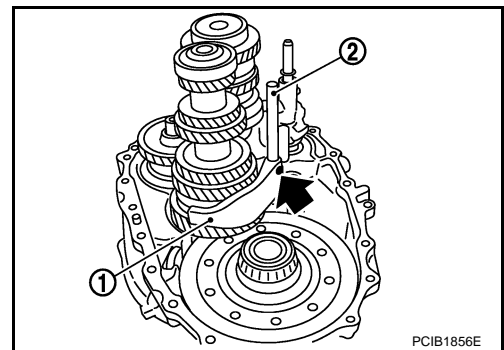

29. Remove striking rod assembly (1).

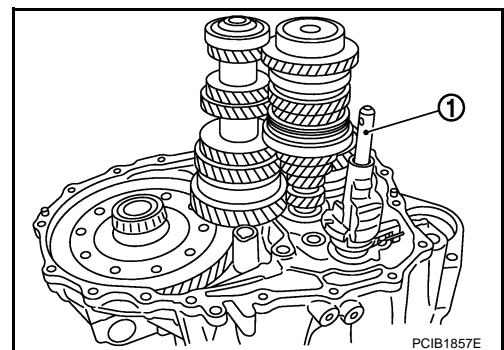

# TRANSAXLE ASSEMBLY

[RS6F52A]

## < SERVICE INFORMATION >

30. Remove gear components from clutch housing in the following procedure.

- a. Remove a set of input shaft assembly, mainshaft assembly, and reverse idler gear assembly by tapping the tip of input shaft from the back of the clutch housing with a plastic hammer.

**CAUTION:**

**Always withdraw mainshaft straight out. Failure to do so can damage resin oil channel on clutch housing side.**

- b. Remove final drive assembly.

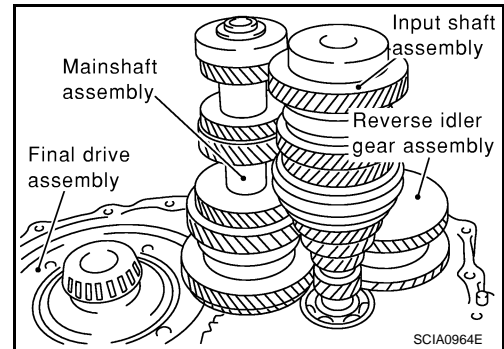

31. Remove magnet from clutch housing.

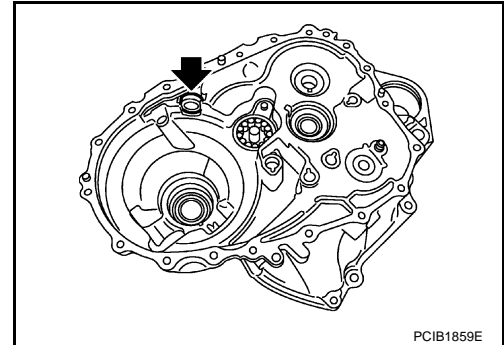

32. Remove mainshaft bearing retainer and then mainshaft front bearing from clutch housing using the puller.

**CAUTION:**

**Do not damage clutch housing, mainshaft front bearing, or oil channel.**

33. Remove oil channel from clutch housing.

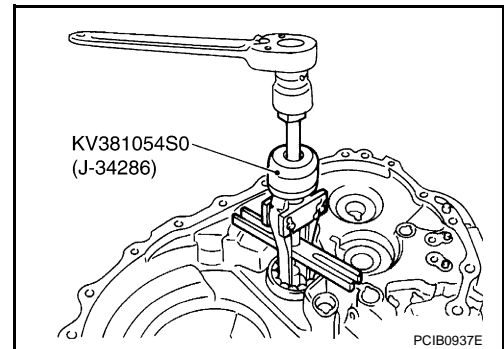

34. Remove differential side bearing outer race (clutch housing side) from clutch housing using the puller.

**CAUTION:**

**Do not damage clutch housing or differential side bearing outer race.**

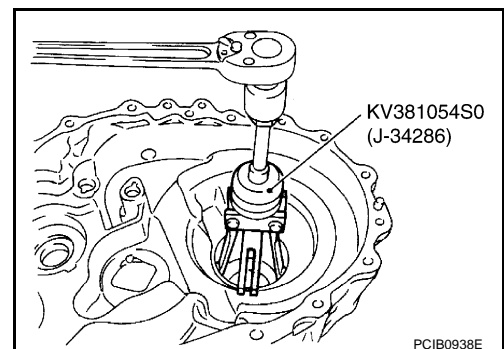

35. Remove input shaft oil seal from clutch housing.

**CAUTION:**

**Do not damage clutch housing.**

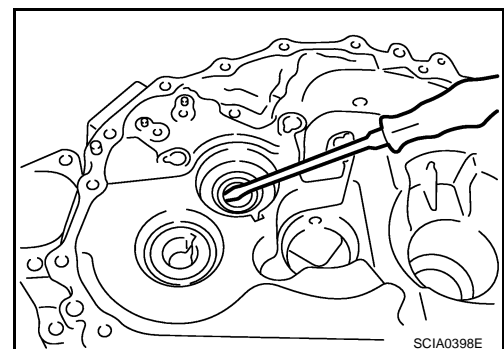

A  
B  
MT  
D  
E  
F  
G  
H  
I  
J  
K  
L  
M  
N  
O  
P

# TRANSAXLE ASSEMBLY

< SERVICE INFORMATION >

[RS6F52A]

36. Remove differential side oil seal from clutch housing.

**CAUTION:**

Do not damage clutch housing.

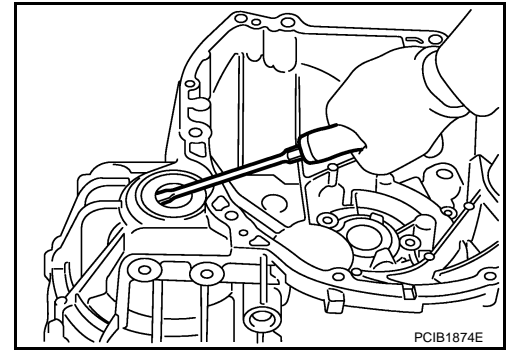

## ASSEMBLY

1. Install differential side oil seal (1) to clutch housing using Tool (A).

Dimension "H" : -0.5 - 0.5 mm (-0.020 - 0.020 in)

Tool number : ST33400001 (J-26082)

**CAUTION:**

- Do not reuse differential side oil seal.
- When installing, do not incline differential side oil seal.
- Do not damage clutch housing.

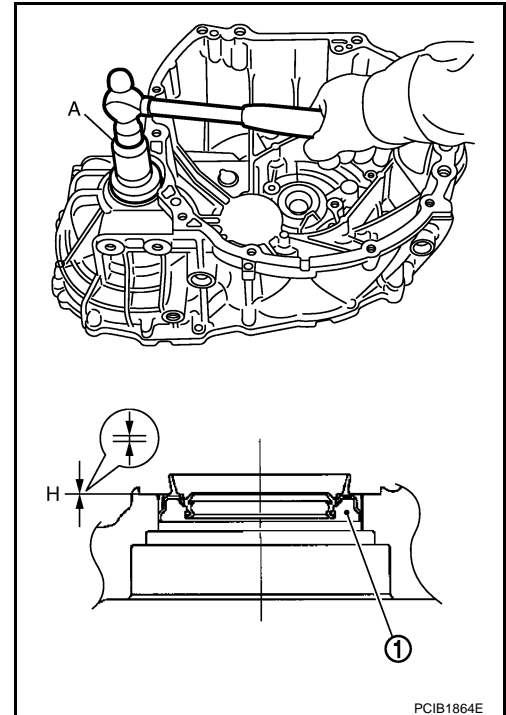

2. Install input shaft oil seal (1) to clutch housing using Tool (A).

Dimension "H" : 1.1 - 2.1 mm (0.043 - 0.083 in)

Tool number : ST35321000 ( — )

**CAUTION:**

- Do not reuse input shaft oil seal.
- When installing, do not incline input shaft oil seal.
- Do not damage clutch housing.

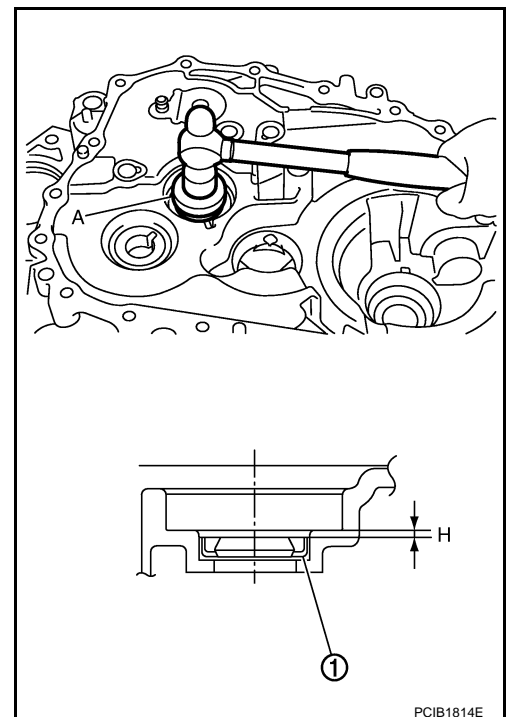



# TRANSAXLE ASSEMBLY

< SERVICE INFORMATION >

[RS6F52A]

3. Install differential side bearing outer race (clutch housing side) to clutch housing using Tools.

**CAUTION:**

Replace differential side bearing and differential side bearing outer race as a set.

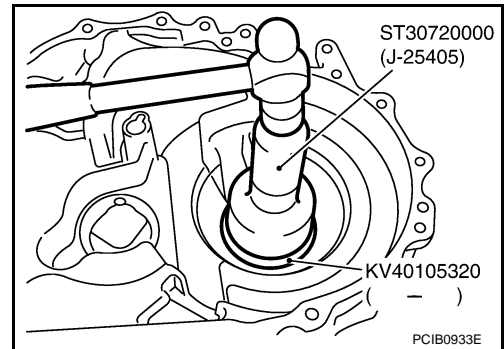

4. Install oil channel (1) on mainshaft side.

**CAUTION:**

When installing oil channel, fit the rib (A) of oil channel into the processed area of the spot facing (B).

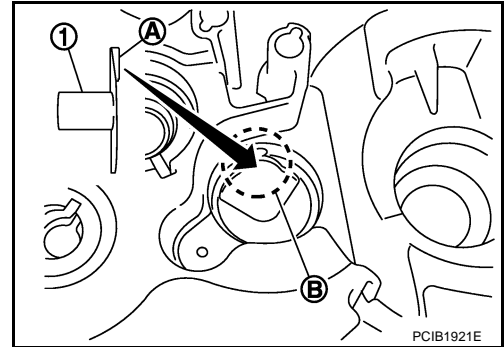

5. Install mainshaft front bearing to clutch housing using Tool.

**CAUTION:**

Be careful with the orientation of mainshaft front bearing.

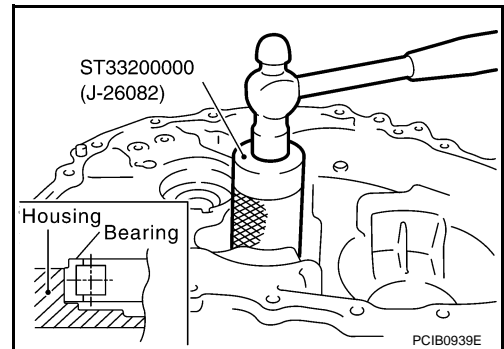

6. Install mainshaft bearing retainer (1) to clutch housing and tighten bolt to the specified torque.

- 2 : Mainshaft front bearing  
3 : Oil channel

**CAUTION:**

Install with punched surface facing up.

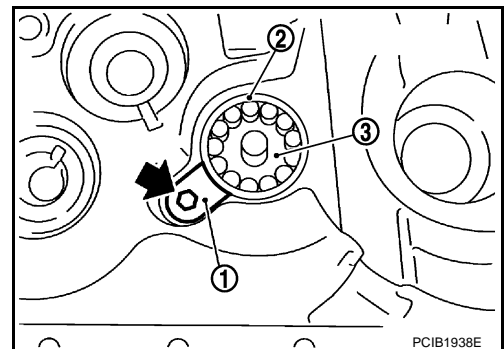

7. Install magnet to clutch housing.

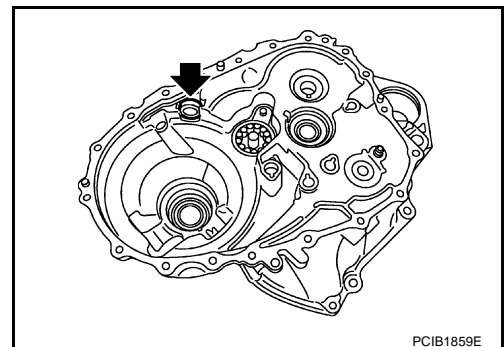

A  
B  
MT  
D  
E  
F  
G  
H  
I  
J  
K  
L  
M  
N  
O  
P

# TRANSAXLE ASSEMBLY

< SERVICE INFORMATION >

[RS6F52A]

8. Install final drive assembly into clutch housing.

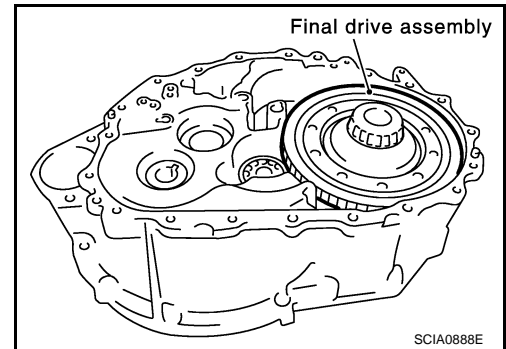

9. Install input shaft assembly, mainshaft assembly, and reverse idler gear assembly into clutch housing.

**CAUTION:**

- Wrap a tape, etc. to the spline of input shaft so as not to damage the input shaft oil seal.
- Be careful with the orientation of reverse idler shaft.

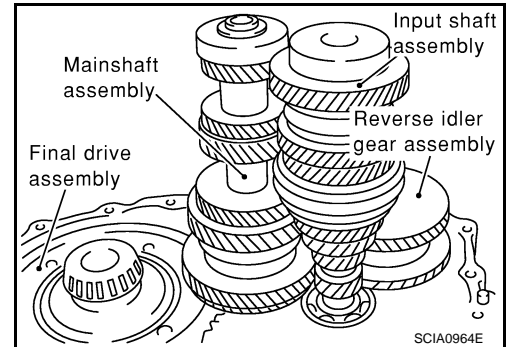

10. Install striking rod assembly (1) into clutch housing.

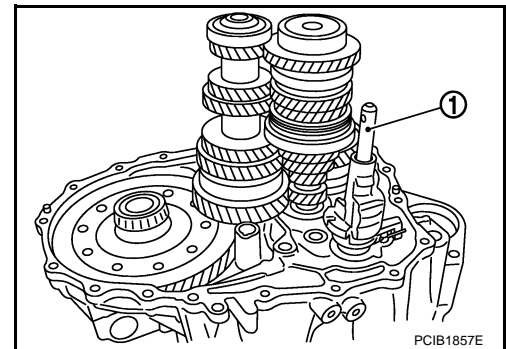

**CAUTION:**

- Check that return spring is securely seated in the groove on return pin.

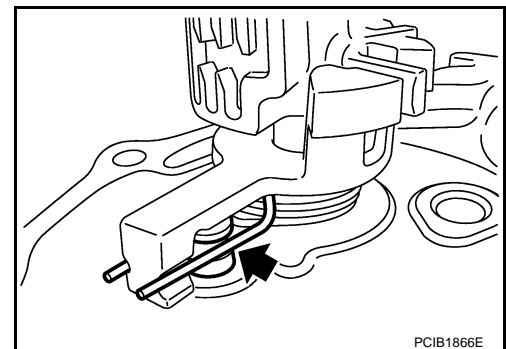

# TRANSAXLE ASSEMBLY

[RS6F52A]

## < SERVICE INFORMATION >

11. Install 1st-2nd shift fork (1) and 1st-2nd fork rod (2) and then install retaining pin to 1st-2nd shift fork.

**CAUTION:**

- Do not reuse retaining pin.
- Be careful with the orientation of 1st-2nd shift fork and 1st-2nd fork rod.
- Assemble retaining pin from the direction shown by the arrow until it becomes flush with the end surface of 1st-2nd shift fork.

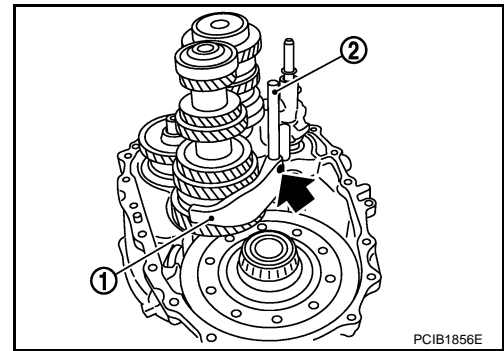

12. Install 3rd-4th shift fork (1) to 3rd-4th coupling sleeve.

**CAUTION:**

- Be careful with the orientation of 3rd-4th shift fork.

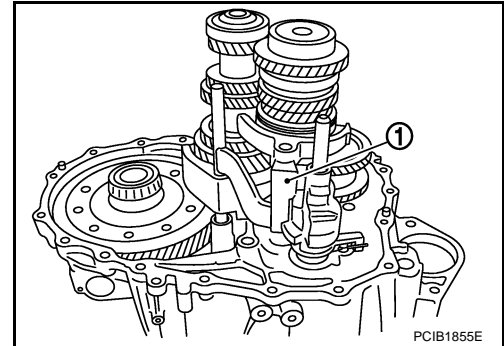

13. Install 5th-6th shift fork (1) and 5th-6th fork rod (2) and then install retaining pin to 5th-6th shift fork.

**CAUTION:**

- Do not reuse retaining pin.
- Be careful with the orientation of 5th-6th shift fork and 5th-6th fork rod.
- Assemble retaining pin from the direction shown by the arrow until it becomes flush with the end surface of 5th-6th shift fork.

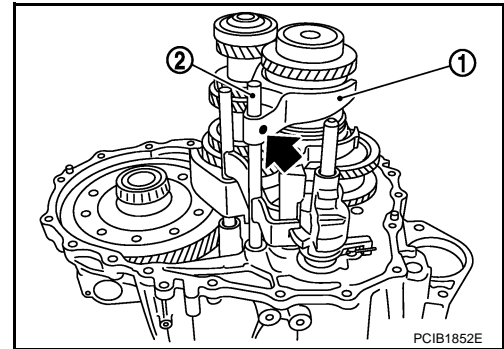

14. Install 3rd-4th fork rod (2) and then install retaining pin to 3rd-4th shift fork (1).

**CAUTION:**

- Do not reuse retaining pin.
- Be careful with the orientation of 3rd-4th fork rod.
- Assemble retaining pin from the direction shown by the arrow until it becomes flush with the end surface of 3rd-4th shift fork.

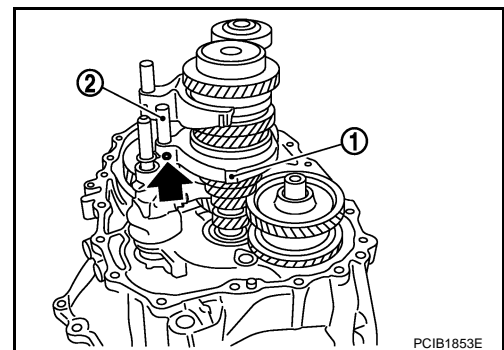

15. Install reverse shift fork (1) and reverse fork rod (2).

**CAUTION:**

- Be careful with the orientation of reverse shift fork and reverse fork rod.

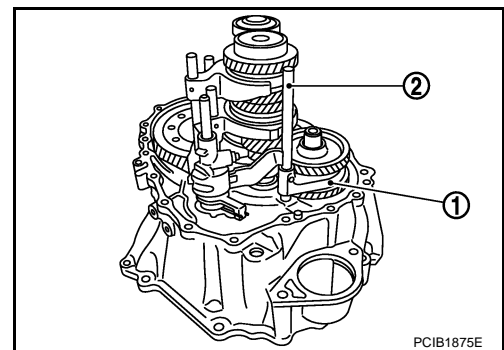

A  
B  
MT  
D  
E  
F  
G  
H  
I  
J  
K  
L  
M  
N  
O  
P

# TRANSAXLE ASSEMBLY

[RS6F52A]

## < SERVICE INFORMATION >

16. Rotate striking lever of striking rod assembly as shown. Then rotate reverse fork rod to a position where bracket of reverse fork rod does not interfere with striking lever of striking rod assembly.

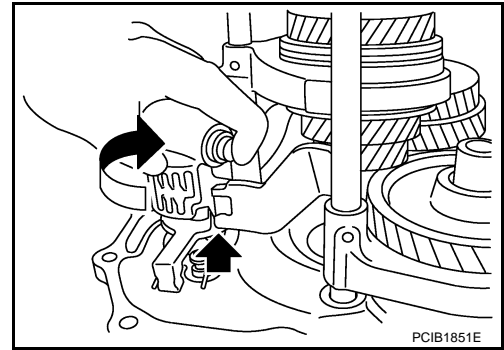

17. Install retaining pin to reverse shift fork (1).

2 : Reverse fork rod

**CAUTION:**

- Do not reuse retaining pin.
- Assemble retaining pin from the direction shown by the arrow until it becomes flush with the end surface of reverse shift fork.

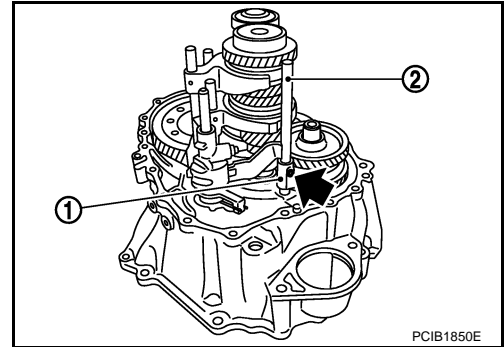

18. Install selected differential side bearing adjusting shim(s) and differential side bearing outer race (transaxle case side).
19. Install selected reverse idler gear adjusting shim onto reverse idler gear assembly.
20. Install selected input shaft rear bearing adjusting shim onto input shaft.
21. Install selected striking rod adjusting shim and striking rod shim onto striking rod assembly.
22. Install shifter lever oil seal (1) and striking rod oil seal (2) to transaxle case using suitable tool.

**Dimension "H" : 0 - 1.0 mm (0 - 0.039 in)**

**CAUTION:**

- Do not reuse shifter lever oil seal or striking rod oil seal.
- When installing, do not incline shifter lever oil seal or striking rod oil seal.
- Do not damage transaxle case.

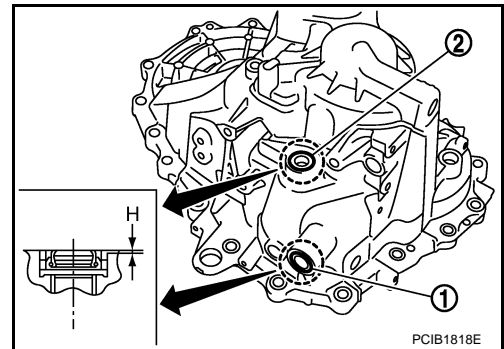

# TRANSAXLE ASSEMBLY

[RS6F52A]

## < SERVICE INFORMATION >

23. Install differential side oil seal (1) to transaxle case using Tool (A).

Dimension "H" : -0.5 - 0.5 mm (-0.020 - 0.020 in)

Tool number : ST30720000 (J-25405)

**CAUTION:**

- Do not reuse differential side oil seal.
- When installing, do not incline differential side oil seal.
- Do not damage transaxle case.

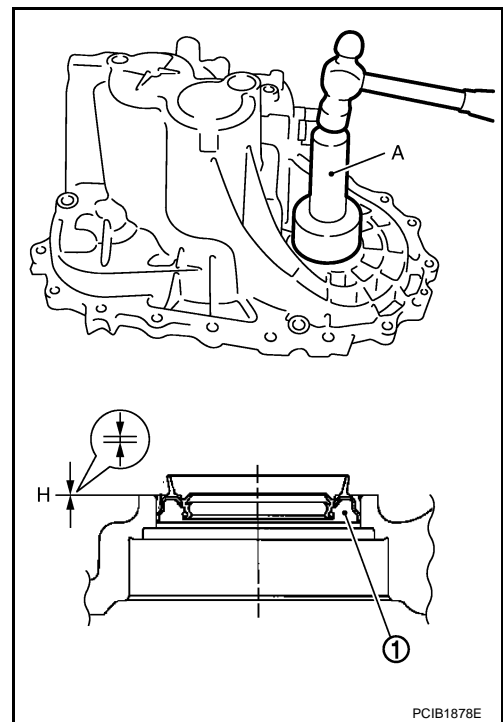

PCIB1878E

24. Install shifter lever B (1) and shifter lever A (2) to transaxle case.

**CAUTION:**

Be careful with the orientation of shifter lever B and shifter lever A.

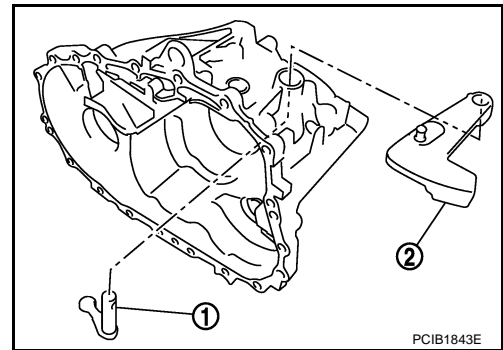

PCIB1843E

25. Install retaining pin to shifter lever A.

**CAUTION:**

- Do not reuse retaining pin.
- Assemble retaining pin from the direction shown by the arrow until it becomes flush with the end surface of shifter lever A.

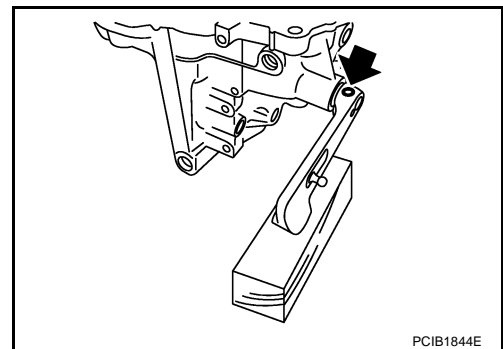

PCIB1844E

26. Install transaxle case following the procedures below.

- a. Install selected mainshaft rear bearing adjusting shim into transaxle case.

A  
B  
MT  
D  
E  
F  
G  
H  
I  
J  
K  
L  
M  
N  
O  
P

# TRANSAXLE ASSEMBLY

[RS6F52A]

## < SERVICE INFORMATION >

- b. Install oil gutter A (1) and oil gutter B (2) to transaxle case.

**CAUTION:**

Insert the tab (A) of oil gutter A and oil gutter B into transaxle case.

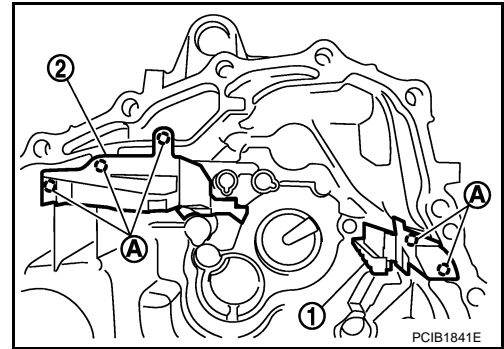

- c. Temporarily install snap ring of mainshaft rear bearing into transaxle case.

**CAUTION:**

Do not reuse snap ring.

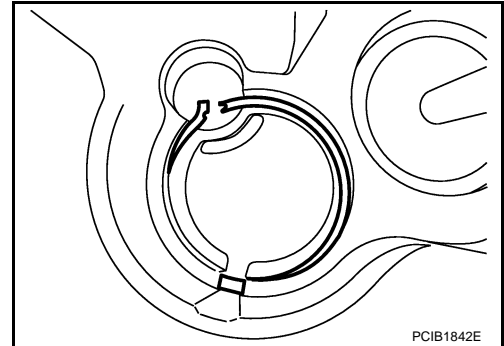

- d. Apply recommended sealant to mating surface of clutch housing as shown.

- Use Genuine Silicone RTV or an equivalent. Refer to [GI-42, "Recommended Chemical Product and Sealant"](#).

**CAUTION:**

- Remove old sealant adhering to the mounting surfaces. Also remove any moisture, oil, or foreign material adhering to both mounting surfaces.
- Apply sealant so as not to break the bead.
- The width of sealant bead is 1 - 2 mm (0.04 - 0.08 in).
- The height of sealant bead is 0.4 - 1 mm (0.016 - 0.04 in).
- The overlap length of both ends of sealant bead is 3 - 5 mm (0.12 - 0.20 in).

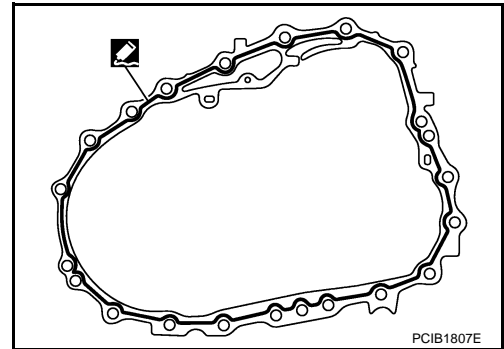

- e. With shifter lever A (1) held in the position shown, temporarily assemble transaxle case to clutch housing.

**CAUTION:**

Do not damage striking rod oil seal.

**NOTE:**

Make sure to hold shifter lever A in the position shown. Otherwise transaxle case cannot be installed to clutch housing.

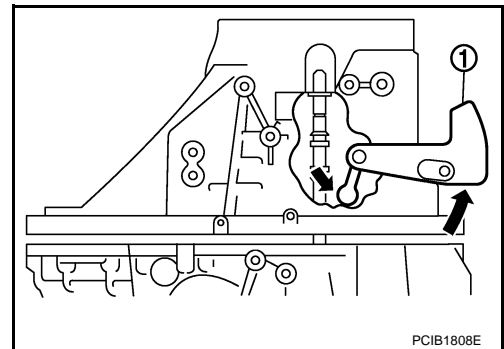

# TRANSAXLE ASSEMBLY

[RS6F52A]

## < SERVICE INFORMATION >

- f. While rotating shifter lever A (1) in the direction of the arrow shown, assemble transaxle case to clutch housing.

2 : shifter lever B

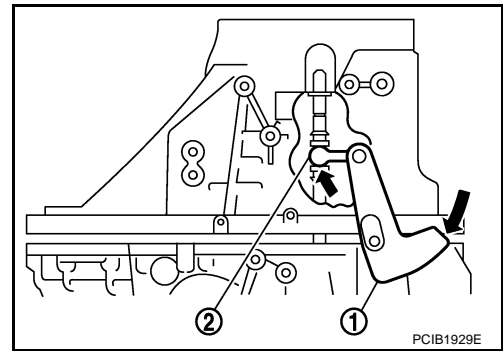

- g. Accessing from the bore plug hole, expand snap ring at mainshaft rear bearing so that the ring catches the periphery of mainshaft rear bearing.  
h. Temporarily tighten transaxle case bolts.

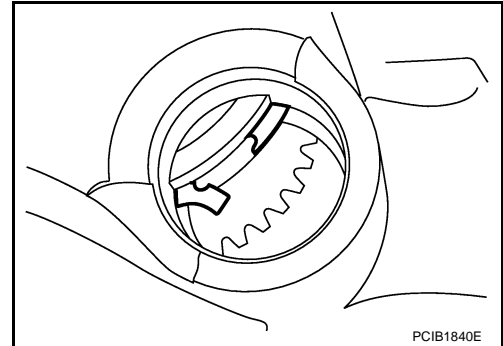

- i. Shift the shifter lever A (1) to 2nd gear position.

### NOTE:

- The 2nd gear position is attained when shifter lever A is in the position shown.

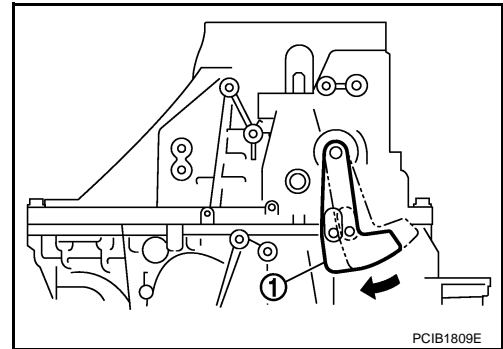

- When transaxle is shifted to the 2nd gear position, mainshaft assembly is lifted.

- j. Seat snap ring in the groove on mainshaft rear bearing. If snap ring is not seated in the groove on mainshaft rear bearing, remove transaxle case and repeat the procedure from step d.

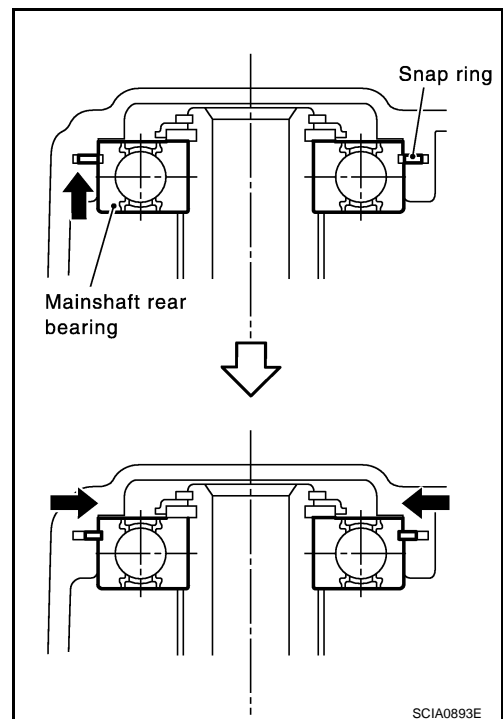

A  
B  
MT  
D  
E  
F  
G  
H  
I  
J  
K  
L  
M  
N  
O  
P

# TRANSAXLE ASSEMBLY

[RS6F52A]

## < SERVICE INFORMATION >

k. Tighten transaxle case bolts to the specified torque.

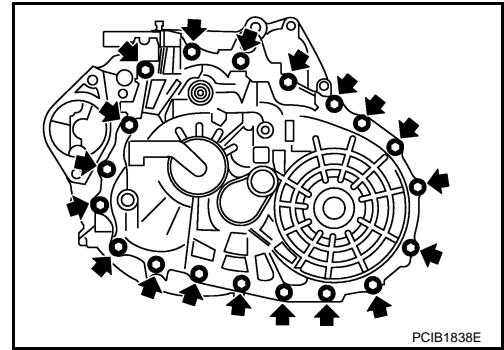

l. Shift the shifter lever A (1) to neutral position.

**NOTE:**

The neutral position is attained when shifter lever A is in the position shown.

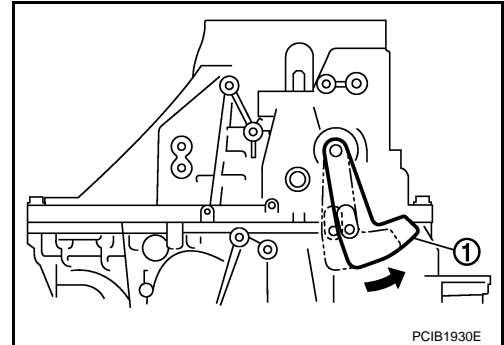

27. Install bore plug to transaxle case using Tool.

**CAUTION:**

**Do not reuse bore plug.**

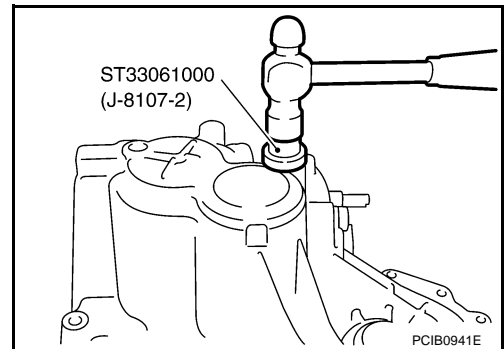

28. Install selector lever to transaxle case and then install retaining pin to selector lever.

**CAUTION:**

- Do not reuse retaining pin.
- Assemble retaining pin from the direction shown by the arrow until it becomes flush with the end surface of selector lever.

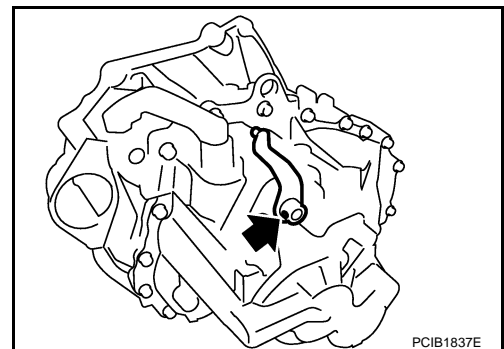

29. Install guide bolt following the procedures below.

a. Shift the shifter lever A and selector lever to neutral position.



# TRANSAXLE ASSEMBLY

[RS6F52A]

## < SERVICE INFORMATION >

- b. Visually confirm from the guide bolt mounting hole (C) that the lever is securely set to neutral position (A). If it is not in the neutral position, repeat the procedure from step a.

1 : Guide bolt

**CAUTION:**

The guide groove (D) of striking rod assembly will be damaged when assembling guide bolt with the lever is in except neutral position (B).

- c. Check continuity between terminals of park/neutral position (PNP) switch to confirm it in the neutral position. If it is not in the neutral position, remove park/neutral position (PNP) switch and repeat the procedure from step a. Refer to [MT-63, "Checking"](#).

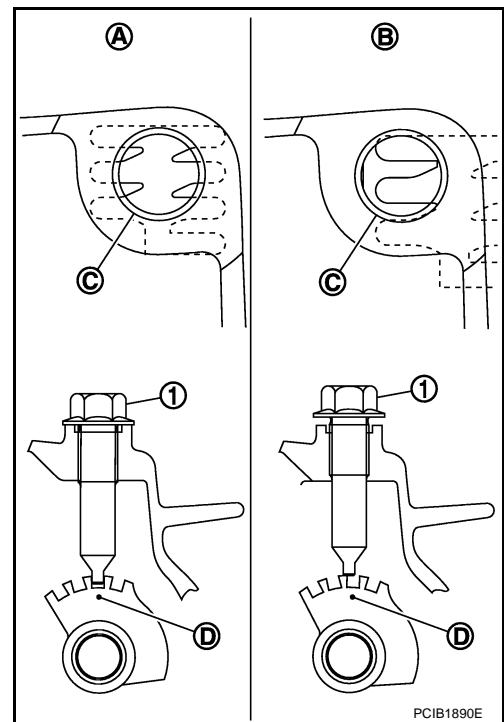

- d. Install guide bolt to transaxle case and then tighten guide bolt to the specified torque.

**CAUTION:**

Do not reuse guide bolt.

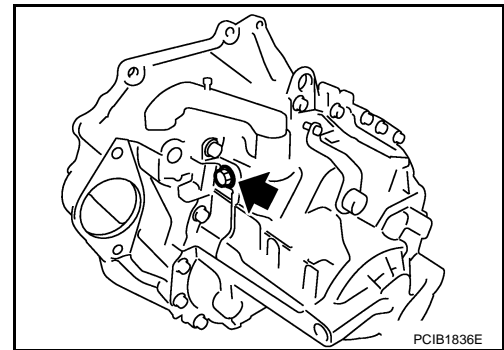

30. Apply recommended sealant to threads of park/neutral position (PNP) switch (1). Then install it to transaxle case and tighten to the specified torque.

• Use Genuine Silicone RTV or an equivalent. Refer to [GI-42, "Recommended Chemical Product and Sealant"](#).

**CAUTION:**

Remove old sealant and oil adhering to threads.

31. Install plunger to transaxle case.

32. Apply recommended sealant to threads of back-up lamp switch (2). Then install it to transaxle case and tighten to the specified torque.

• Use Genuine Silicone RTV or an equivalent. Refer to [GI-42, "Recommended Chemical Product and Sealant"](#).

**CAUTION:**

Remove old sealant and oil adhering to threads.

33. Install air breather tube (3) to transaxle case.

**CAUTION:**

• Do not reuse air breather tube.

• Assemble air breather tube until its collar element contacts with transaxle case.

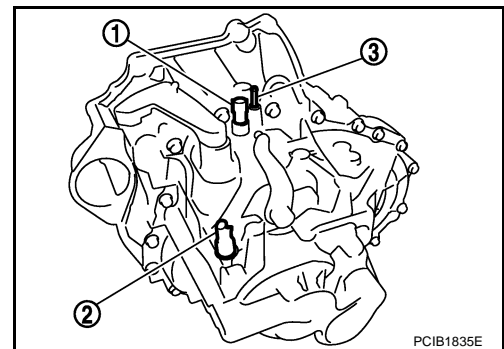

# TRANSAXLE ASSEMBLY

[RS6F52A]

## < SERVICE INFORMATION >

34. Install gasket onto plug and then install them into transaxle case. Tighten plug to the specified torque.

**CAUTION:**

**Do not reuse gasket.**

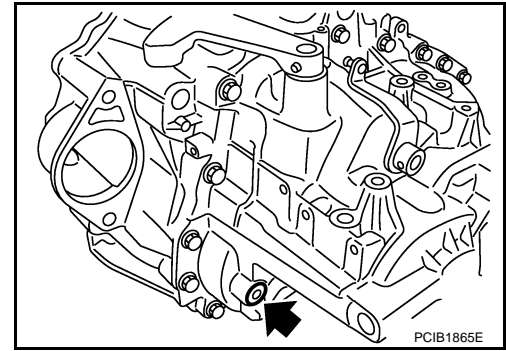

35. Install gasket onto drain plug and then install them into clutch housing. Tighten drain plug to the specified torque.

**CAUTION:**

**Do not reuse gasket.**

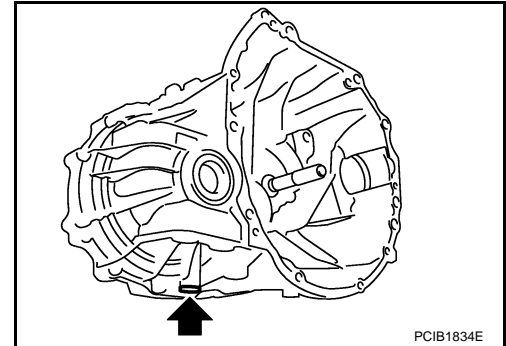

36. Install O-ring onto plug (with ABS models) or speedometer pinion gear (without ABS models) and then install it into clutch housing. Tighten bolt to the specified torque.

**CAUTION:**

- Do not reuse O-ring.
- After oil is filled, tighten bolt to specified torque.

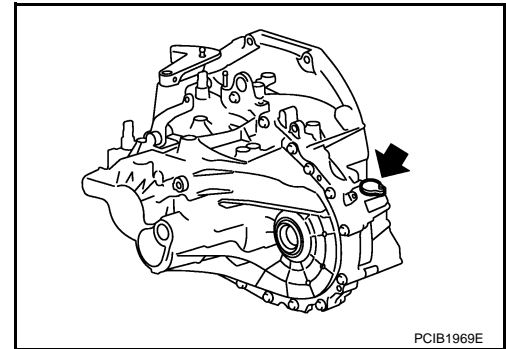

## ADJUSTMENT

### Differential Side Bearing Preload

- When adjusting differential side bearing preload, select adjusting shim for differential side bearing. To select adjusting shim, measure clearance "L" between transaxle case and differential side bearing outer race. Refer to [MT-126, "Available Shims"](#).

**CAUTION:**

**Up to 2 adjusting shims can be selected.**

- Calculate dimension "L" (thickness of adjusting shim) using the following procedure to satisfy specification of preload for differential side bearing.

**Preload** : Refer to [MT-126, "Available Shims"](#).

**Dimension "L"** = (L1 - L2) + Preload

**L** : Thickness of adjusting shim

**L1** : Distance between transaxle case end face and mounting face of adjusting shim

**L2** : Distance between differential side bearing outer race and clutch housing end face

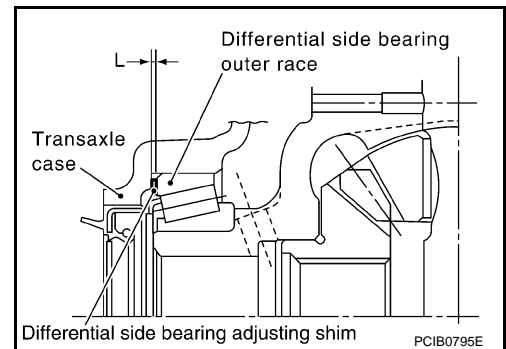

# TRANSAXLE ASSEMBLY

[RS6F52A]

## < SERVICE INFORMATION >

- Using a depth micrometer and straightedge, measure dimension "L1" between transaxle case end face and mounting face of adjusting shim.
- Install differential side bearing outer race onto differential side bearing on final gear side. Holding lightly differential side bearing outer race horizontally by hand, rotate final gear five times or more (for smooth movement of bearing roller).

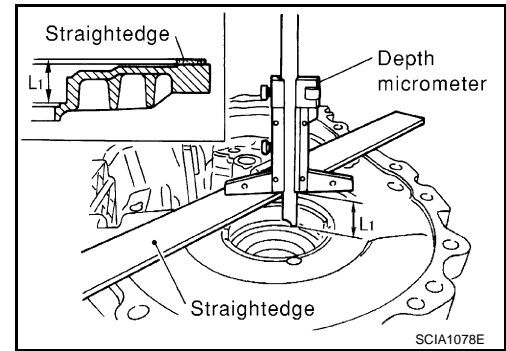

- Using a depth micrometer and straightedge as shown, measure dimension "L2" between differential side bearing outer race and clutch housing end face.

**CAUTION:**

"L2": Measure at 4 point by approximately 90 degrees and use the average value.

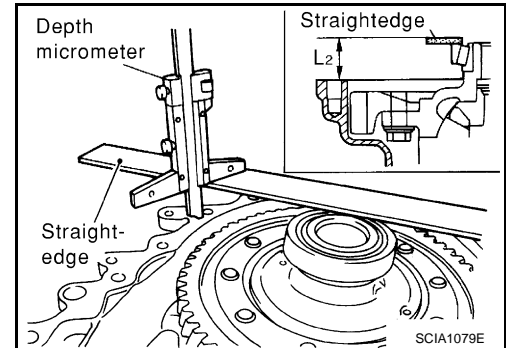

- Install selected differential side bearing adjusting shim and then install differential side bearing outer race (transaxle case side) using the Tool.

**CAUTION:**

Replace differential side bearing and differential side bearing outer race as a set.

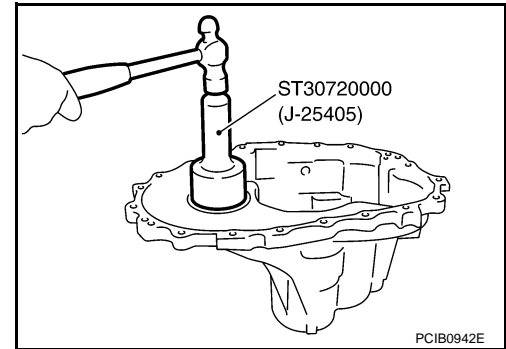

### Reverse Idler Gear End Play

- When adjusting reverse idler gear end play, select adjusting shim for reverse idler gear. To select adjusting shim (1), measure clearance between transaxle case (2) and reverse idler gear (rear) (3). Refer to [MT-125, "Available Adjusting Shims"](#).

**CAUTION:**

Only 1 adjusting shim can be selected.

- Calculate dimension "Q" (thickness of adjusting shim) using the following procedure to satisfy specification of end play for reverse idler gear.

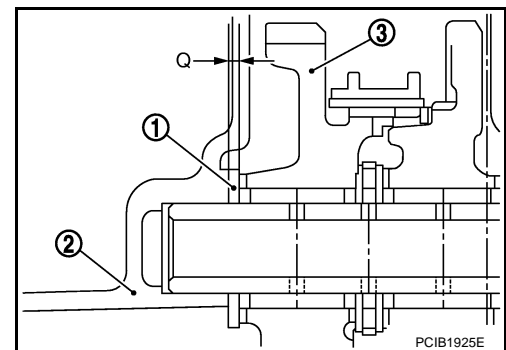

**End play** : Refer to [MT-125, "Available Adjusting Shims"](#).

**Dimension "Q"** = (Q1 - Q2) - End play

**Q** : Thickness of adjusting shim

**Q1** : Distance between transaxle case end face and mounting face of adjusting shim

**Q2** : Distance between clutch housing end face and end face of reverse idler gear (rear)

# TRANSAXLE ASSEMBLY

[RS6F52A]

## < SERVICE INFORMATION >

- Using a depth micrometer and straightedge, measure dimension "Q1" between transaxle case end face and mounting face of adjusting shim.

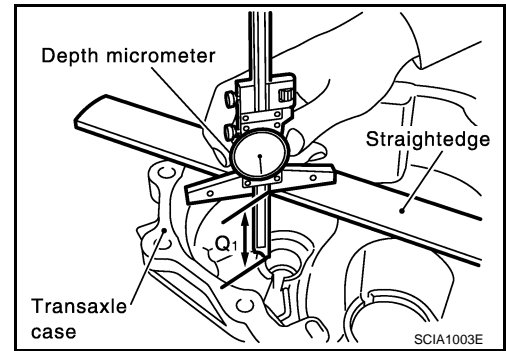

- Using a depth micrometer and straightedge as shown, measure dimension "Q2" between clutch housing (1) end face and end face of reverse idler gear (rear) (2).

**CAUTION:**

**"Q2": Measure at 4 point by approximately 90 degrees and use the average value.**

- Install selected reverse idler gear adjusting shim onto reverse idler gear (rear).

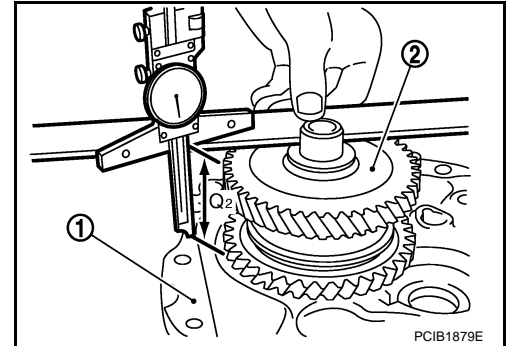

### Input Shaft End Play

- When adjusting input shaft end play, select adjusting shim for input shaft rear bearing. To select adjusting shim, measure clearance between transaxle case and input shaft rear bearing. Refer to [MT-125, "Available Adjusting Shims"](#).

**CAUTION:**

**Only 1 adjusting shim can be selected.**

- Calculate dimension "O" (thickness of adjusting shim) using the following procedure to satisfy specification of end play for input shaft rear bearing.

**End play** : Refer to [MT-125, "Available Adjusting Shims"](#).

**Dimension "O" = (O1 - O2) - End play**

**O** : Thickness of adjusting shim

**O1** : Distance between transaxle case end face and mounting face of adjusting shim

**O2** : Distance between clutch housing end face and end face of input shaft rear bearing

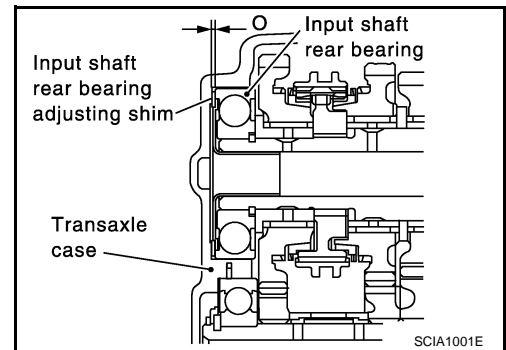

- Using a depth micrometer and straightedge, measure dimension "O1" between transaxle case end face and mounting face of adjusting shim.

**CAUTION:**

**"O1": Measure at 4 point by approximately 90 degrees and use the average value.**

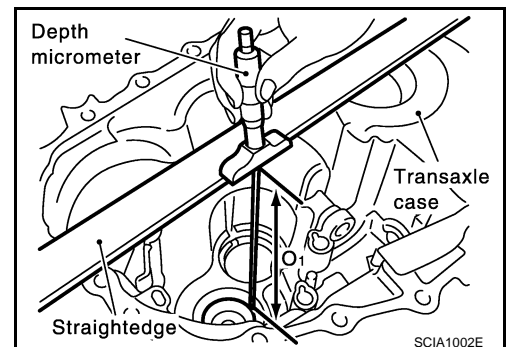

# TRANSAXLE ASSEMBLY

[RS6F52A]

## < SERVICE INFORMATION >

- Using a depth micrometer and straightedge as shown, measure dimension "O<sub>2</sub>" between clutch housing end face and end face of input shaft rear bearing.

**CAUTION:**

**"O<sub>2</sub>": Measure at 4 point by approximately 90 degrees and use the average value.**

- Install selected input shaft rear bearing adjusting shim onto input shaft.

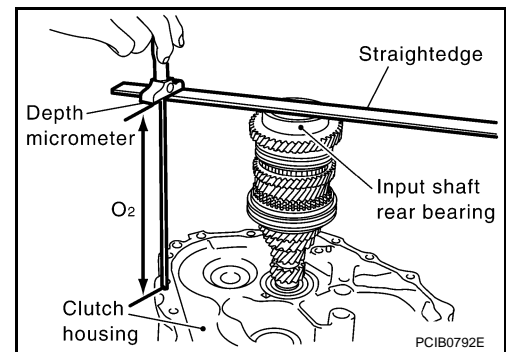

### Striking rod End Play

- When adjusting striking rod end play, select adjusting shim (1) for striking rod (2). To select adjusting shim, measure clearance between transaxle case (3) and striking rod shim (4). Refer to [MT-125, "Available Adjusting Shims"](#).

**CAUTION:**

**Only 1 adjusting shim can be selected.**

- Calculate dimension "R" (thickness of adjusting shim) using the following procedure to satisfy specification of end play for striking rod.

**End play** : Refer to [MT-125, "Available Adjusting Shims"](#).

**Dimension "R" = (R<sub>1</sub> - R<sub>2</sub>) - End play**

**R** : Thickness of adjusting shim

**R<sub>1</sub>** : Distance between transaxle case end face and mounting face of adjusting shim

**R<sub>2</sub>** : Distance between clutch housing end face and end face of striking rod shim

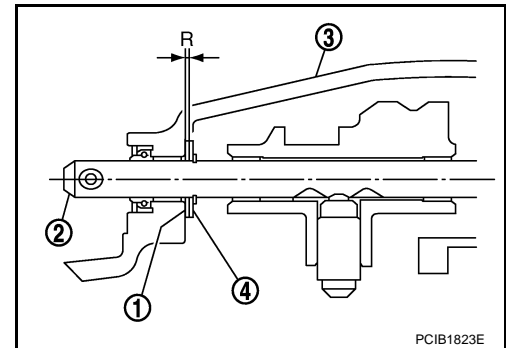

- Using a depth micrometer (A) and straightedge (B), measure dimension "R<sub>1</sub>" between transaxle case (1) end face and mounting face of adjusting shim.

**CAUTION:**

**"R<sub>1</sub>": Measure at 4 point by approximately 90 degrees and use the average value.**

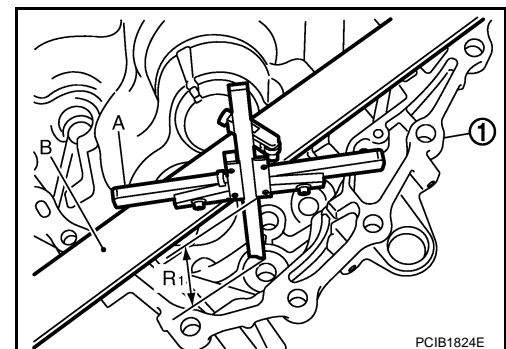

- Using a depth micrometer (A) and straightedge (B) as shown, measure dimension "R<sub>2</sub>" between clutch housing (1) end face and end face of striking rod shim (2).

**CAUTION:**

**"R<sub>2</sub>": Measure at 4 point by approximately 90 degrees and use the average value.**

**When measuring, be careful for the inclination of striking rod assembly and striking rod shim.**

- Install selected striking rod adjusting shim onto striking rod assembly.

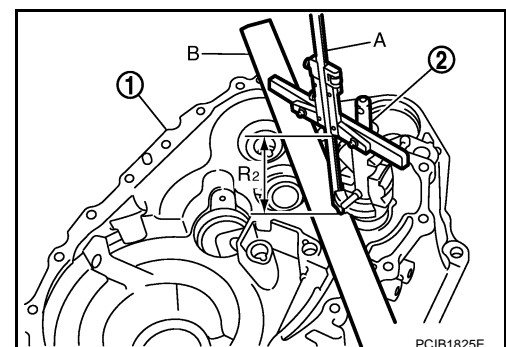

### Mainshaft End Play

# TRANSAXLE ASSEMBLY

[RS6F52A]

## < SERVICE INFORMATION >

- When adjusting mainshaft end play, select adjusting shim (1) for mainshaft rear bearing (2). To select adjusting shim, measure clearance "M" between transaxle case (3) and dummy adjusting shim (4) on mainshaft rear bearing. Refer to [MT-125, "Available Adjusting Shims"](#).

5 : Snap ring

6 : Mainshaft

### CAUTION:

**Only 1 adjusting shim can be selected.**

- Calculate dimension "P" (thickness of adjusting shim) using the following procedure to satisfy specification of end play for mainshaft rear bearing.

**End play** : Refer to [MT-125, "Available Adjusting Shims"](#).

**Dimension "P"** = (M + N) - End play

**P** : Thickness of adjusting shim

**M** : Distance between dummy adjusting shim on mainshaft rear bearing end face and transaxle case end face

**N\*** : Thickness of dummy adjusting shim

\*: Refer to the latest parts information to use a dummy adjusting shim of which part number is the thinnest in thickness. Refer to [MT-125, "Available Adjusting Shims"](#).

- Install transaxle case following the procedures below.
  - Temporarily install snap ring of mainshaft rear bearing into transaxle case.

### CAUTION:

**Do not reuse snap ring.**

- Install dummy adjusting shim (1) to mainshaft assembly.

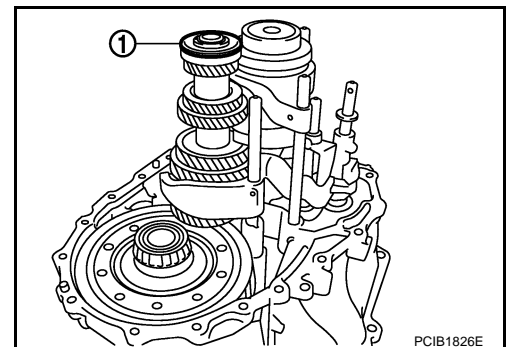
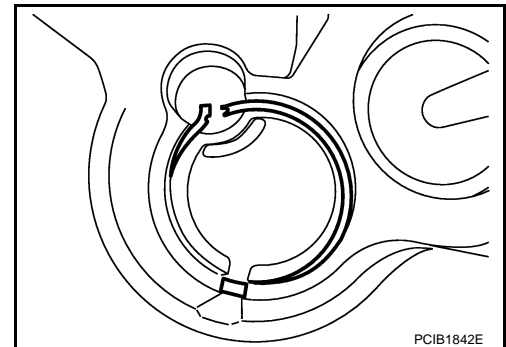
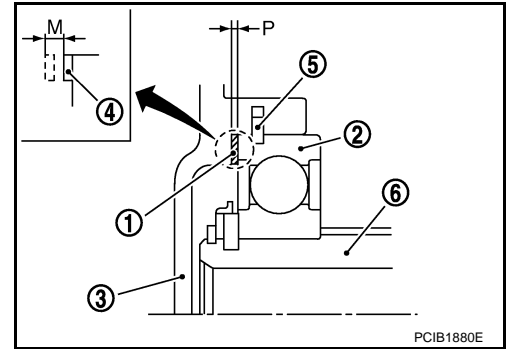

# TRANSAXLE ASSEMBLY

[RS6F52A]

## < SERVICE INFORMATION >

- c. With shifter lever A (1) held in the position shown, temporarily assemble transaxle case to clutch housing.

**CAUTION:**

**Do not damage striking rod oil seal.**

**NOTE:**

Make sure to hold shifter lever A in the position shown. Otherwise transaxle case cannot be installed to clutch housing.

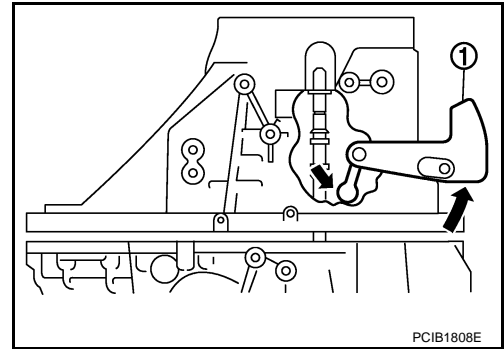

- d. While rotating shifter lever A (1) in the direction of the arrow shown, assemble transaxle case to clutch housing.

2 : shifter lever B

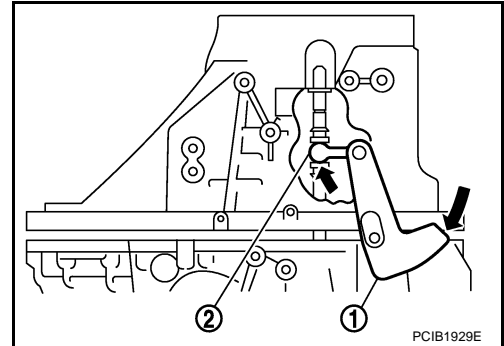

- e. Accessing from the bore plug hole, expand snap ring at mainshaft rear bearing so that the ring catches the periphery of mainshaft rear bearing.

- f. Temporarily tighten transaxle case bolts.

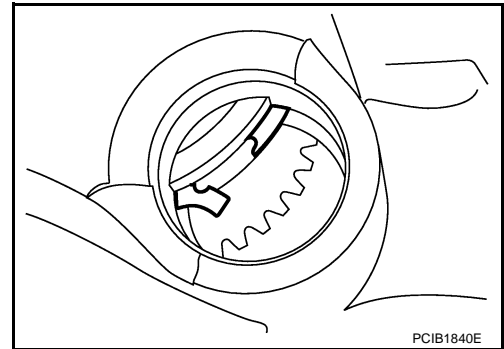

2. Shift the shifter lever A to 2nd gear position.

**NOTE:**

- The 2nd gear position is attained when shifter lever A (1) is in the position shown.

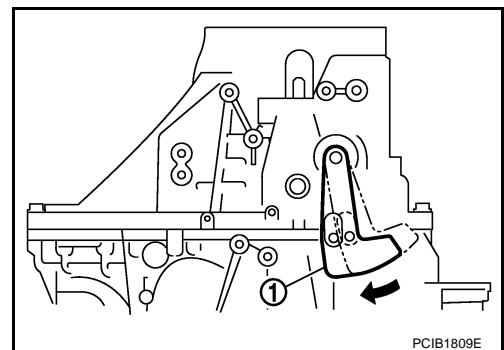

- When transaxle is shifted to the 2nd gear position, mainshaft assembly (1) is lifted.

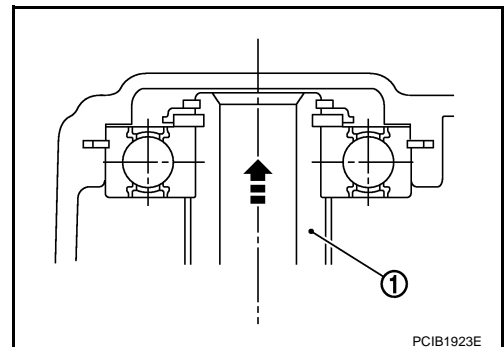

A  
B  
MT  
D  
E  
F  
G  
H  
I  
J  
K  
L  
M  
N  
O  
P

# TRANSAXLE ASSEMBLY

[RS6F52A]

## < SERVICE INFORMATION >

3. Seat snap ring in the groove on mainshaft rear bearing. If snap ring is not seated in the groove on mainshaft rear bearing, remove transaxle case and repeat the procedure 1 from step c.
4. Shift the shifter lever A to 1st gear position, and then shift it to 2nd gear position. Repeat 3 times.

**NOTE:**

- The mainshaft rear bearing position will be stabilized by shifting between 1st gear position and 2nd gear position alternately.
- The 1st gear position is attained when shifter lever A (1) is in the position shown.

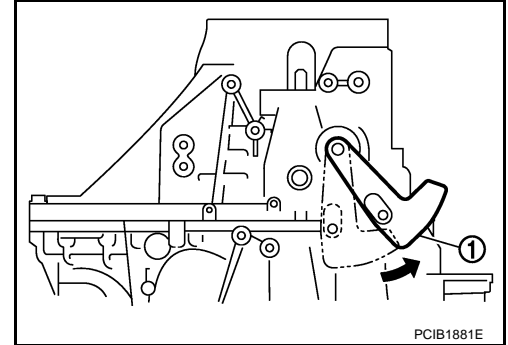

- When transaxle is shifted to the 1st gear position, mainshaft assembly (1) is declined.

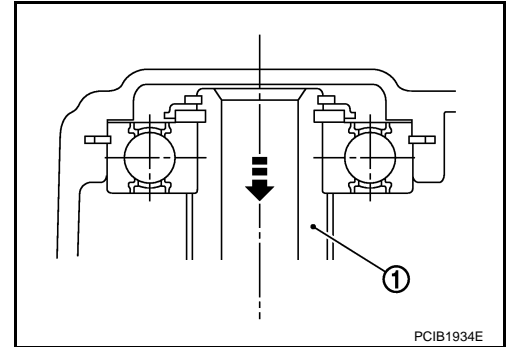

5. Set the dial indicator (A) to dummy adjusting shim (1) through the bore plug mounting hole.

- 2 : Mainshaft rear bearing
- 3 : Snap ring

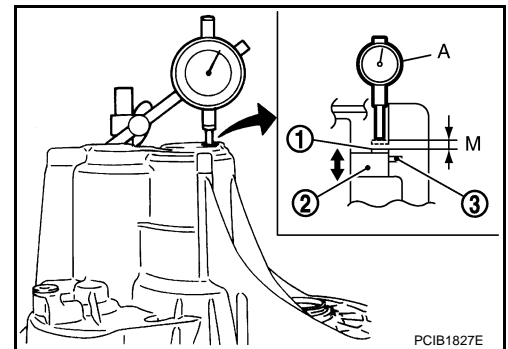



# TRANSAXLE ASSEMBLY

[RS6F52A]

## < SERVICE INFORMATION >

- Shift the shifter lever A (1) to 2nd gear position (A), and then rotate it in the direction of the arrow (C) shown until it stops. Using this position as the reference point, measure the amount of movement when shifting shifter lever A to 1st gear position (B) and rotating it in the direction of the arrow (D) shown until it stops. This measurement is the "M" dimension.
- When measurement "M" is 0 - 0.06 mm (0 - 0.0024 in), adjustment terminates, and the dummy adjusting shim becomes regular adjusting shim. Select adjusting shim from the computed expressions when measurement "M" is over 0.06 mm (0.0024 in).

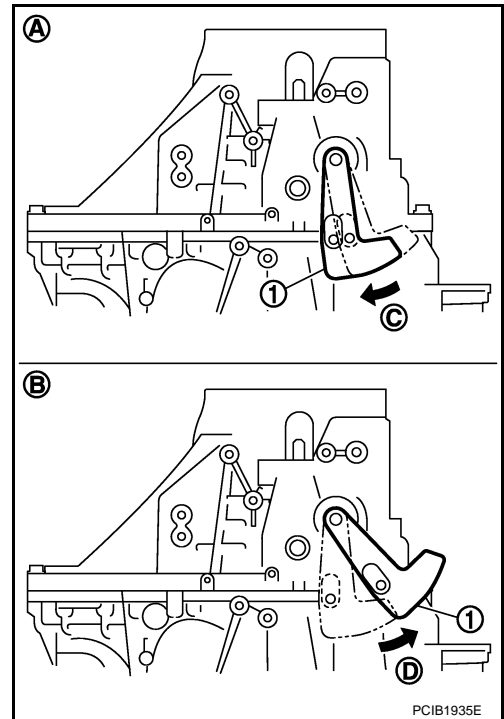

A  
B  
MT  
D  
E  
F  
G  
H  
I  
J  
K  
L  
M  
N  
O  
P

## INPUT SHAFT AND GEARS

### Disassembly and Assembly

INFOID:000000001850887

#### DISASSEMBLY

1. Before disassembling, measure end play for 3rd, 4th, 5th, and 6th input gears.

**End play standard value**

**: Refer to [MT-123, "Gear End Play"](#).**

2. Remove oil channel.

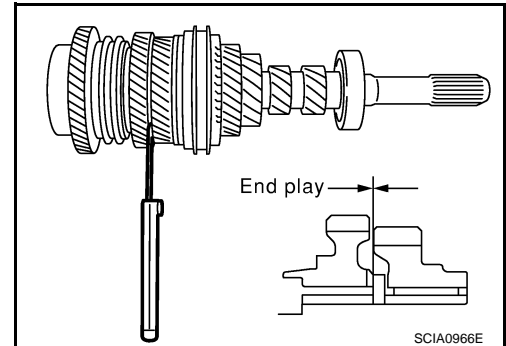

3. Press out input shaft rear bearing using Tool and a puller.
4. Remove snap ring.

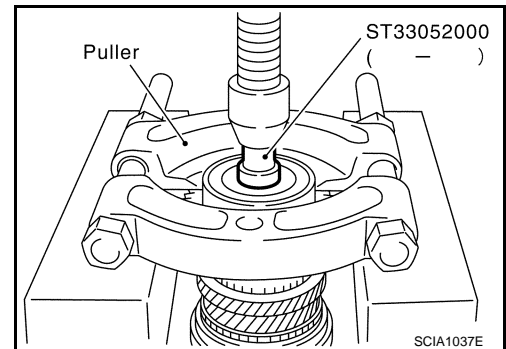

5. Press out 6th input gear, 6th needle bearing, 6th input gear bushing, 5th-6th synchronizer hub assembly, and 5th input gear using Tool (A) and a puller (B).

**Tool number      A: ST33052000 ( — )**

6. Remove 5th needle bearing.

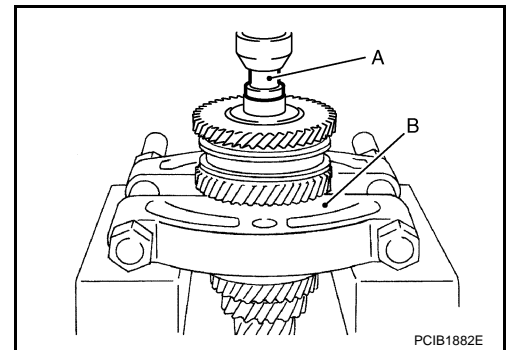

7. Press out 5th input gear bushing, thrust washer, 4th input gear, 4th needle bearing, 4th input gear bushing, 3rd-4th synchronizer hub assembly, and 3rd input gear using Tool and a puller.

8. Remove 3rd needle bearing.

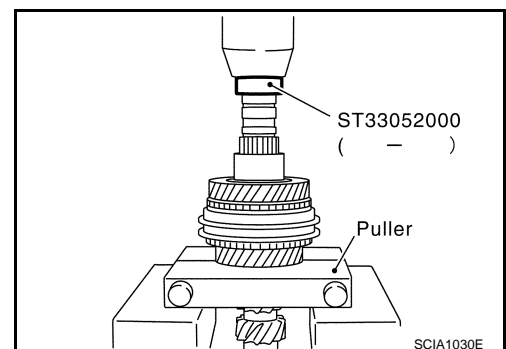

# INPUT SHAFT AND GEARS

[RS6F52A]

## < SERVICE INFORMATION >

9. Press out input shaft front bearing using a puller.

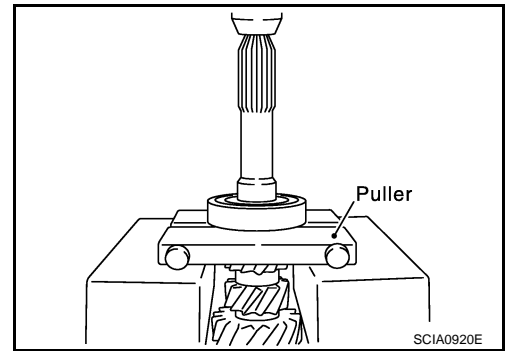

## INSPECTION AFTER DISASSEMBLY

### Input Shaft and Gears

Check items below. If necessary, replace them with new ones.

- Damage, peeling, dent, uneven wear, bending, etc. of shaft
- Excessive wear, damage, peeling, etc. of gears

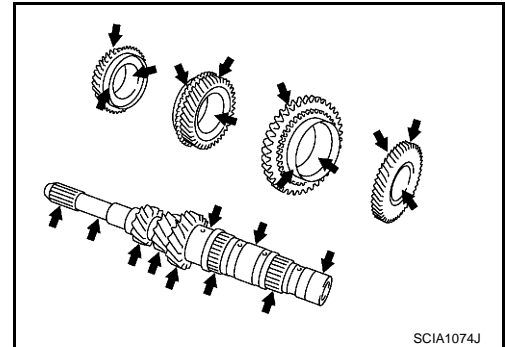

### Synchronizer

Check items below. If necessary, replace them with new ones.

- Damage and excessive wear of contact surfaces of coupling sleeve, synchronizer hub and shifting insert
- Coupling sleeve and synchronizer hub must move smoothly.

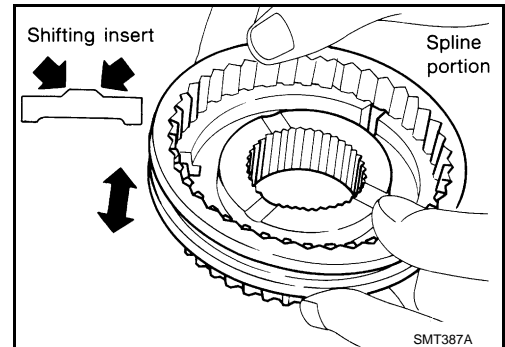

- If any crack, damage, or excessive wear is found on cam face of baulk ring or working face of insert, replace it.

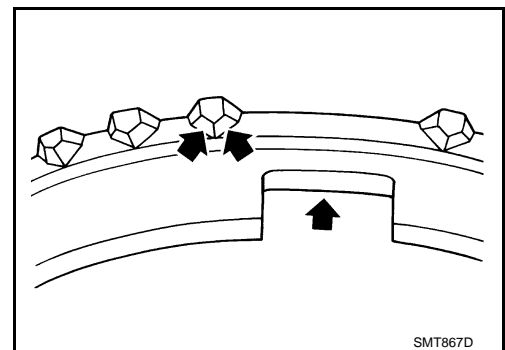

## BAULK RING CLEARANCE

- Single-cone synchronizer (4th, 5th, and 6th)

A  
B  
MT  
D  
E  
F  
G  
H  
I  
J  
K  
L  
M  
N  
O  
P

# INPUT SHAFT AND GEARS

[RS6F52A]

## < SERVICE INFORMATION >

Push baulk ring on the cone and measure the clearance between baulk ring and cone. If measurement is below limit, replace it with a new one.

### Clearance

**Standard value** : Refer to [MT-123, "Baulk Ring Clearance"](#).

**Limit value** : Refer to [MT-123, "Baulk Ring Clearance"](#).

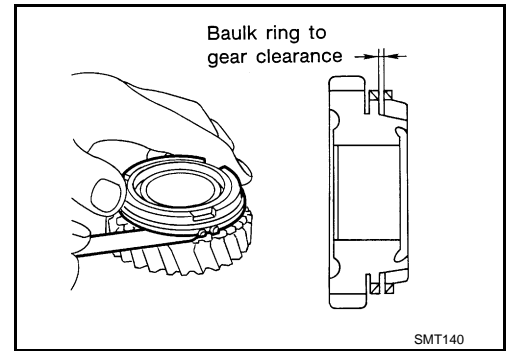

### • Double-cone synchronizer (3rd)

Check the clearance between outer baulk ring, synchronizer cone, and inner baulk ring as follows.

#### CAUTION:

The clearances "A" and "B" are controlled with outer baulk ring, synchronizer cone, and inner baulk ring as a set. Replace them as a set if the clearances are outside the limit value.

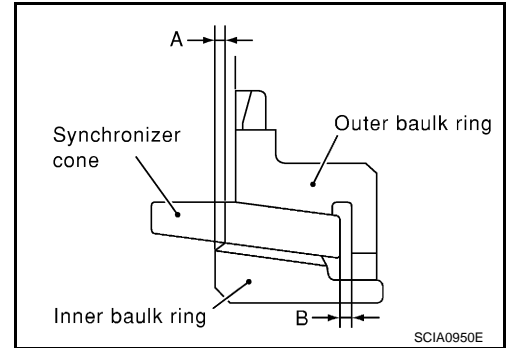

1. Measure the clearance "A" at 2 points or more diagonally opposite using a dial indicator. And then calculate mean value.

### Clearance "A"

**Standard value** : Refer to [MT-123, "Baulk Ring Clearance"](#).

**Limit value** : Refer to [MT-123, "Baulk Ring Clearance"](#).

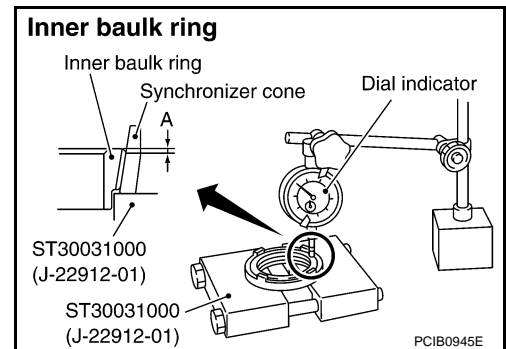

2. Measure the clearance "B" at 2 points or more diagonally opposite using a feeler gauge. And then calculate mean value.

### Clearance "B"

**Standard value** : Refer to [MT-123, "Baulk Ring Clearance"](#).

**Limit value** : Refer to [MT-123, "Baulk Ring Clearance"](#).

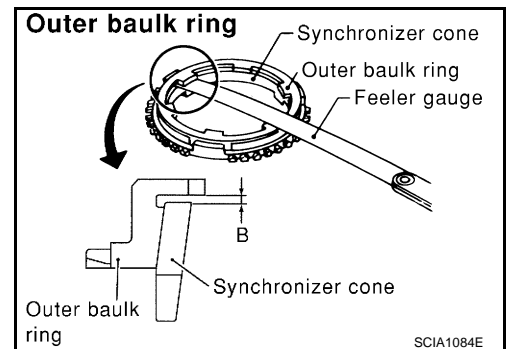

Bearing

# INPUT SHAFT AND GEARS

[RS6F52A]

## < SERVICE INFORMATION >

Check items below. If necessary, replace them with new ones.

- Damage and rough rotation of bearing

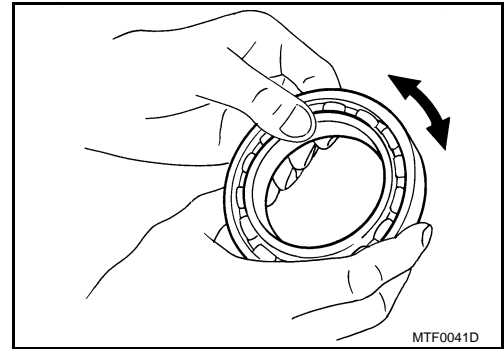

A

B

MT

D

## ASSEMBLY

1. Install 3rd needle bearing to input shaft.
2. Install 3rd input gear, 3rd inner baulk ring, 3rd synchronizer cone, and 3rd outer baulk ring to input shaft.  
**CAUTION:**  
**Replace 3rd inner baulk ring, 3rd synchronizer cone, and 3rd outer baulk ring as a set.**
3. Install 3rd-4th spread springs, 3rd-4th shifting inserts, and 3rd-4th synchronizer hub onto 3rd-4th coupling sleeve.

E

F

### **CAUTION:**

- Be careful with orientation of 3rd-4th synchronizer hub.
- Never reuse 3rd-4th synchronizer hub and 3rd-4th coupling sleeve.
- Replace 3rd-4th synchronizer hub and 3rd-4th coupling sleeve as a set.

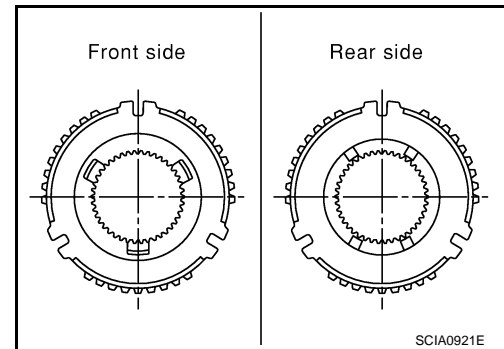

G

H

I

J

- Be careful with orientation of 3rd-4th coupling sleeve.

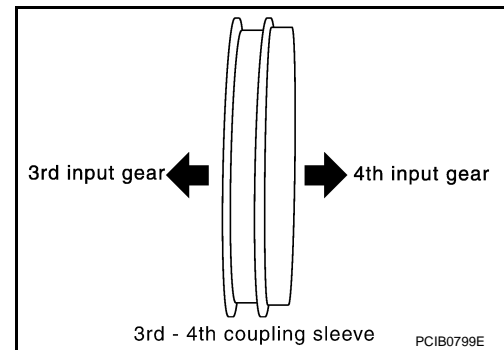

K

L

M

- Be sure not to hook center projection of 2 spread springs on same shifting insert.

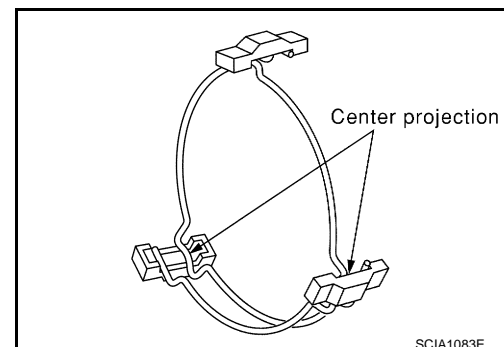

N

O

P

# INPUT SHAFT AND GEARS

[RS6F52A]

< SERVICE INFORMATION >

4. Press in 3rd-4th synchronizer hub assembly using Tool  
**CAUTION:**  
Align grooves of 3rd-4th shifting insert and 3rd outer baulk ring.

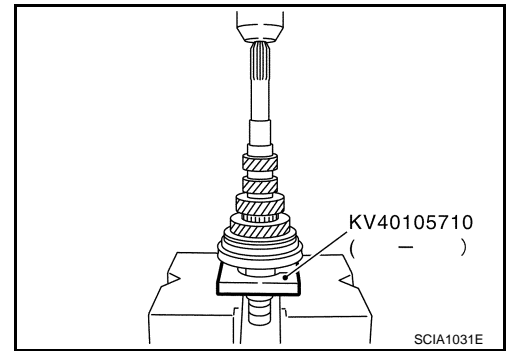

5. Press in 4th input gear bushing using Tool.
6. Install 4th baulk ring.
7. Install 4th needle bearing and 4th input gear to input shaft.

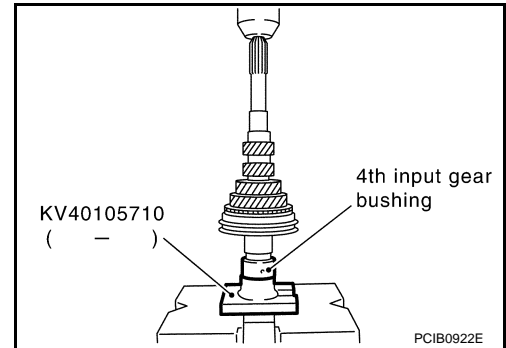

8. Select thrust washer so that dimension "C2" satisfies the standard value below. Then install thrust washer onto input shaft. Refer to [MT-124, "Available Thrust Washer"](#).

**Standard value for dimension "C2"**

**: Refer to [MT-124, "Available Thrust Washer"](#).**

**CAUTION:**

**Only one thrust washer can be selected.**

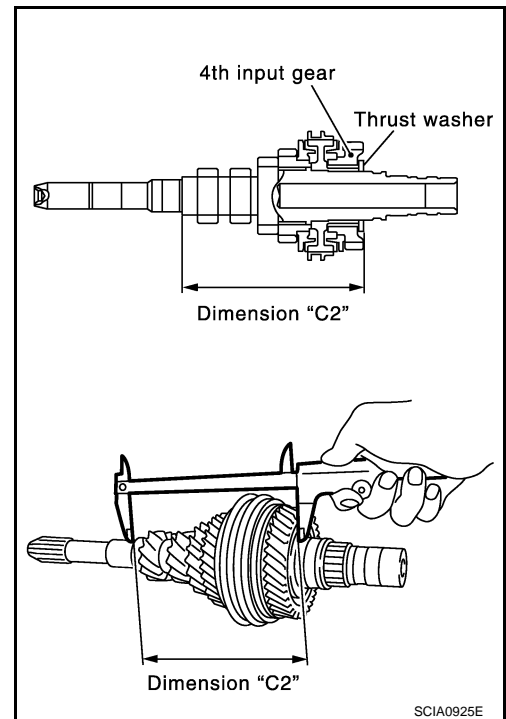

9. Press in 5th input gear bushing using Tool.  
**CAUTION:**  
Never reuse 5th input gear bushing.
10. Install 5th needle bearing and 5th input gear to input shaft.
11. Install 5th baulk ring.

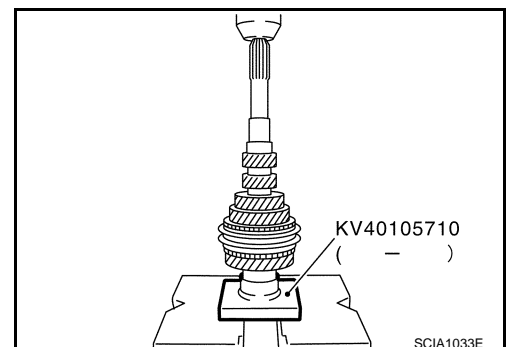

# INPUT SHAFT AND GEARS

[RS6F52A]

< SERVICE INFORMATION >

12. Install 5th-6th synchronizer hub, 5th-6th spread springs, and 5th-6th shifting inserts onto 5th-6th coupling sleeve.

**CAUTION:**

- Be careful with orientation of 5th-6th synchronizer hub.

A : Front side

B : Rear side

- Never reuse 5th-6th synchronizer hub and 5th-6th coupling sleeve.
- Replace 5th-6th synchronizer hub and 5th-6th coupling sleeve as a set.

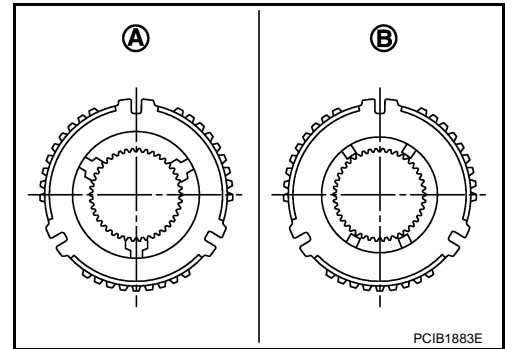

- Be careful with orientation of 5th-6th coupling sleeve.

A : 5th input gear side

B : 6th input gear side

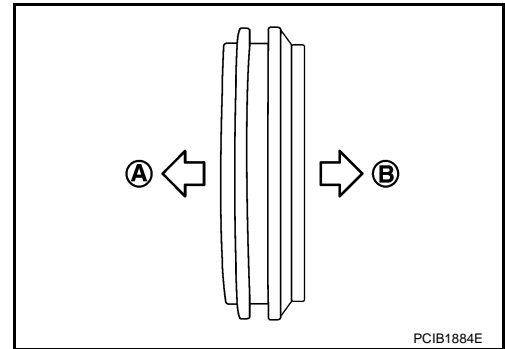

- Be sure not to hook center projection of 2 spread springs on same shifting insert.

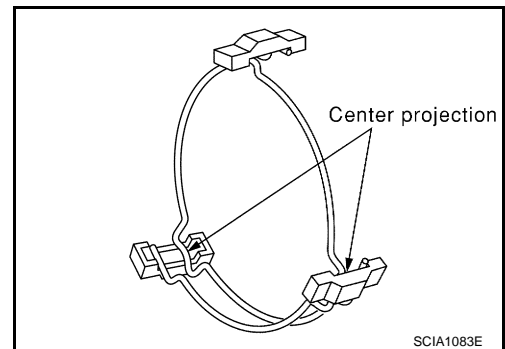

13. Press in 5th-6th synchronizer hub assembly using Tool.

**CAUTION:**

- Align grooves of 5th-6th shifting insert and 5th baulk ring.

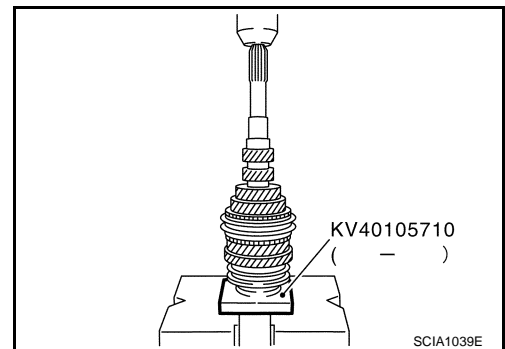

A  
B  
MT  
D  
E  
F  
G  
H  
I  
J  
K  
L  
M  
N  
O  
P

# INPUT SHAFT AND GEARS

[RS6F52A]

## < SERVICE INFORMATION >

14. Install 6th needle bearing, 6th input gear, 6th baulk ring onto 6th input gear bushing and then press in 6th input gear bushing onto input shaft using Tool.

**Tool number** : ST33200000 (J-26082 )

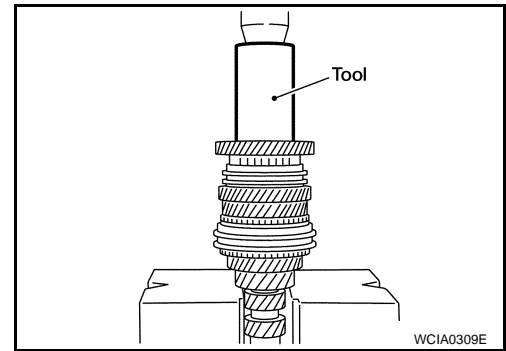

15. Install snap ring onto input shaft and make sure that end play (gap between snap ring and groove) of 6th input gear bushing satisfies the standard value.

**End play standard value**

:Refer to [MT-123, "Available Snap Rings"](#).

- If measurement is outside the standard range, select snap ring. Refer to [MT-123, "Available Snap Rings"](#).

**CAUTION:**

**Never reuse snap ring.**

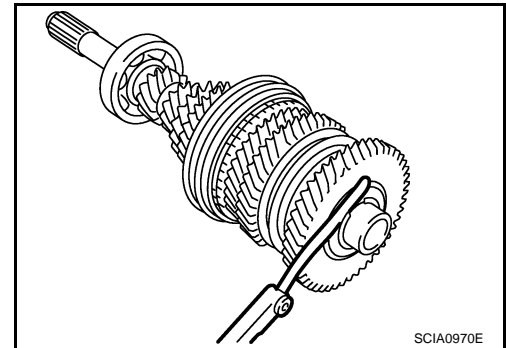

16. Press in input shaft rear bearing using Tool.

**Tool number** : ST30901000 (J-26010-01)

**CAUTION:**

**Install input shaft rear bearing with its brown surface facing the 6th input gear side.**

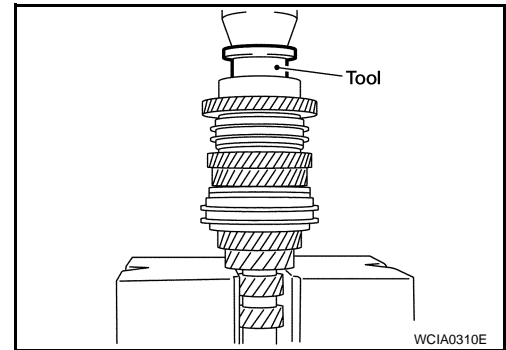

17. Press in input shaft front bearing Tools (A), (B).

**Tool number** A: ST33052000 ( — )

B: ST30032000 (J-26010-01)

18. Install oil channel onto input shaft.

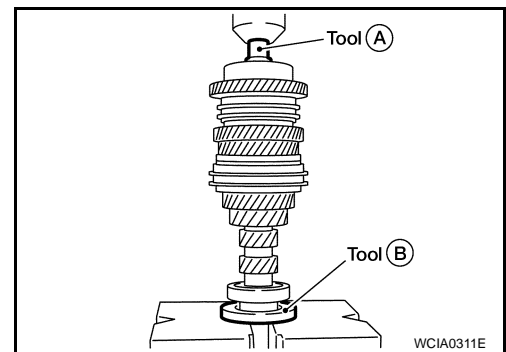

19. Check end play of 3rd, 4th, 5th, and 6th input gears.

**End play standard value**

: Refer to [MT-123, "Gear End Play"](#).

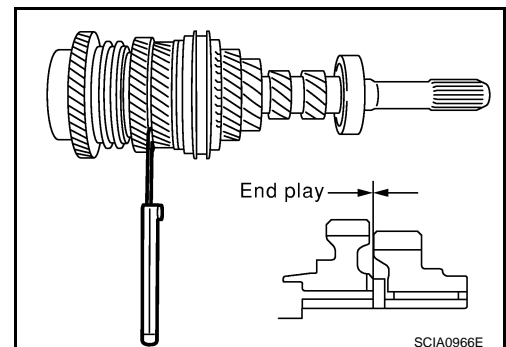



## MAINSHAFT AND GEARS

### Disassembly and Assembly

INFOID:000000001850888

#### DISASSEMBLY

1. Before disassembling, measure the end play of 1st and 2nd main gears.

**End play standard value**

: Refer to [MT-123, "Gear End Play"](#).

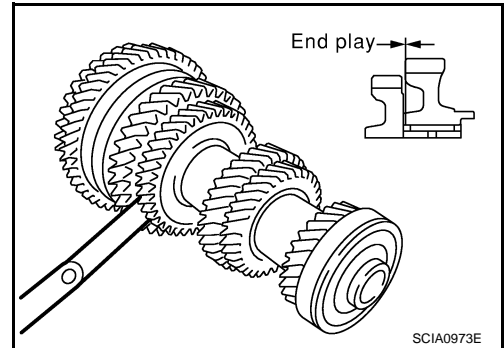

2. Remove snap ring.
3. Remove C-ring holder and then remove mainshaft C-rings.

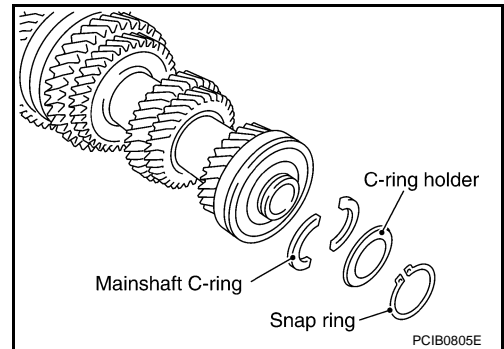

4. Press out mainshaft rear bearing, 6th main gear adjusting shim, and 6th main gear using Tool and a puller.
5. Remove 5th-6th mainshaft spacer.

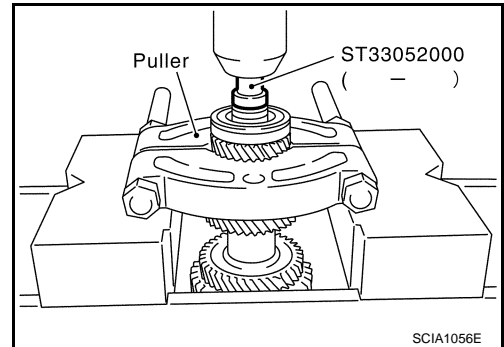

6. Press out 4th main gear and 5th main gear using Tool and a puller.
7. Remove 4th main gear adjusting shim.
8. Remove 3rd-4th mainshaft spacer.

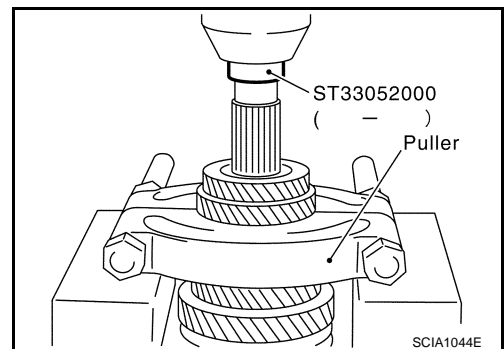

A  
B  
MT  
D  
E  
F  
G  
H  
I  
J  
K  
L  
M  
N  
O  
P

# MAINSHAFT AND GEARS

[RS6F52A]

## < SERVICE INFORMATION >

9. Press out 3rd main gear and 2nd main gear using Tool (A) and a puller (B).

**Tool number**      **A: KV40105020 ( — )**

10. Remove 2nd needle bearing.

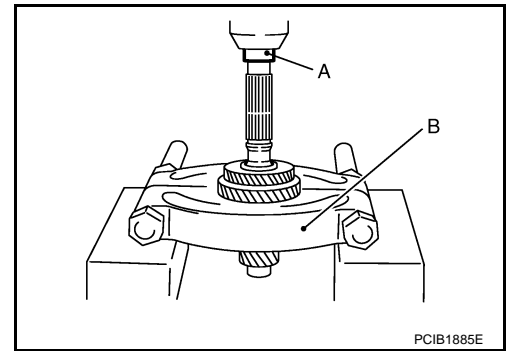

11. Press out 2nd main gear bushing, 1st-2nd synchronizer hub assembly, 1st main gear, 1st needle bearing, 1st main gear bushing, and reverse main gear using Tool (A).

**Tool number**      **A: KV40105020 ( — )**

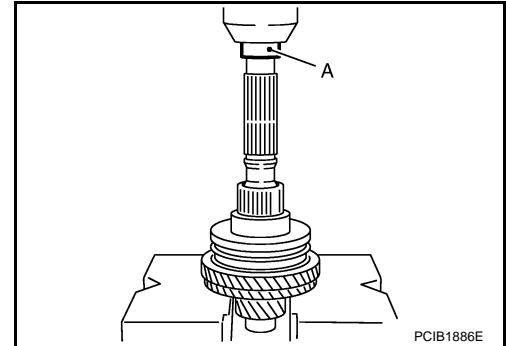

## INSPECTION AFTER DISASSEMBLY

### Mainshaft and Gears

Check items below. If necessary, replace them with new ones.

- Damage, peeling, dent, uneven wear, bending, and other non-standard conditions of the shaft.
- Excessive wear, damage, peeling, and other non-standard conditions of the gears.

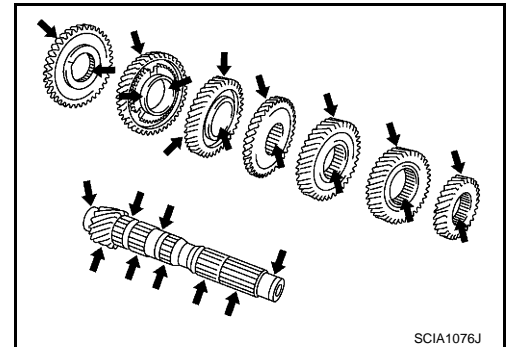

### Synchronizer

Check items below. If necessary, replace them with new ones.

- Damage and unusual wear on contact surfaces of coupling sleeve, synchronizer hub and shifting insert.
- Coupling sleeve and synchronizer hub must move smoothly.

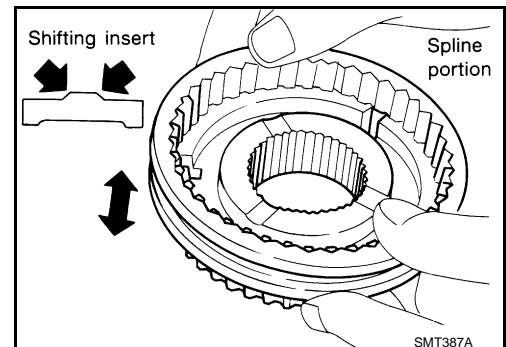

# MAINSHAFT AND GEARS

[RS6F52A]

## < SERVICE INFORMATION >

- If any crack, damage, or excessive wear is found on cam face of baulk ring or working face of insert, replace it.

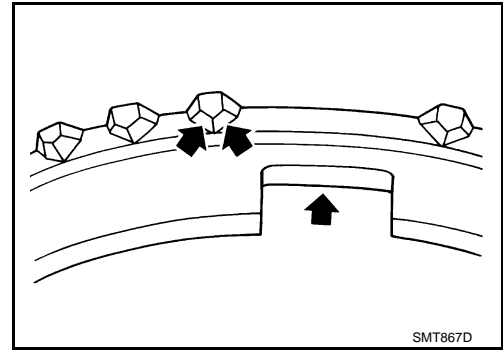

## BAULK RING CLEARANCE

### Triple-cone synchronizer (1st and 2nd)

- Check the clearance between outer baulk ring, synchronizer cone, and inner baulk ring as follows.

#### CAUTION:

The clearances "A", "B", and "C" are controlled with outer baulk ring, synchronizer cone, and inner baulk ring as a set. Replace them as a set if the clearances are outside the limit value.

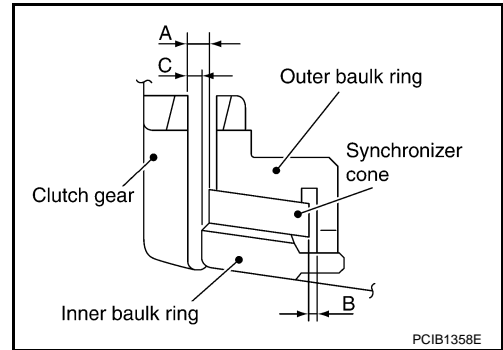

1. Measure the clearance "A" at 2 points or more diagonally opposite using a feeler gauge when pressing baulk ring toward clutch gear taper cone. And then calculate mean value.

#### Clearance "A"

Standard value : Refer to [MT-123, "Baulk Ring Clearance"](#).

Limit value : Refer to [MT-123, "Baulk Ring Clearance"](#).

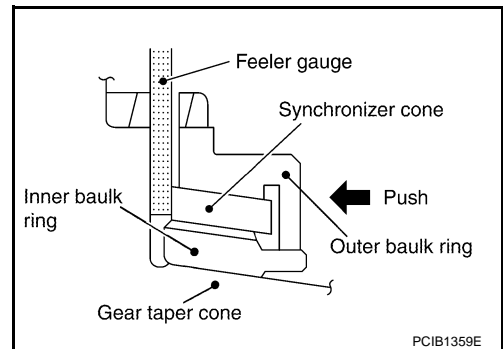

2. Measure the clearance "B" at 2 points or more diagonally opposite using a feeler gauge. And then calculate mean value.

#### Clearance "B"

Standard value : Refer to [MT-123, "Baulk Ring Clearance"](#).

Limit value : Refer to [MT-123, "Baulk Ring Clearance"](#).

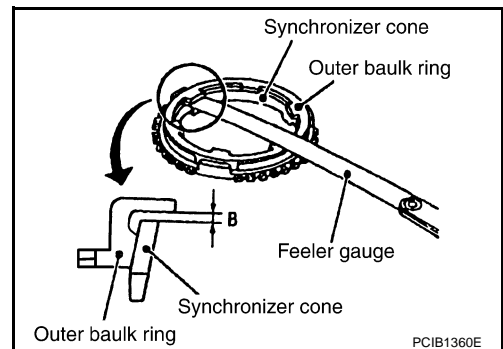

# MAINSHAFT AND GEARS

[RS6F52A]

## < SERVICE INFORMATION >

3. Measure the clearance "C" at 2 points or more diagonally opposite using a feeler gauge when pressing baulk ring toward clutch gear taper cone. And then calculate mean value.

### Clearance "C"

**Standard value** : Refer to [MT-123, "Baulk Ring Clearance"](#).

**Limit value** : Refer to [MT-123, "Baulk Ring Clearance"](#).

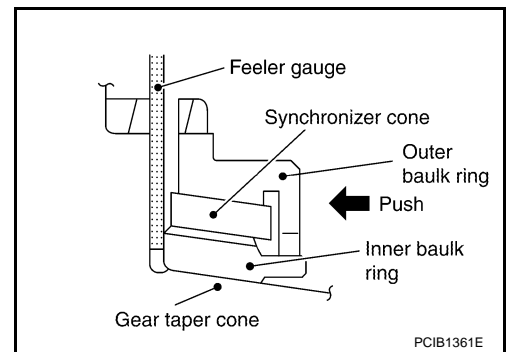

### Bearing

Check items below. If necessary, replace them with new ones.

- Damage and rough rotation of bearing

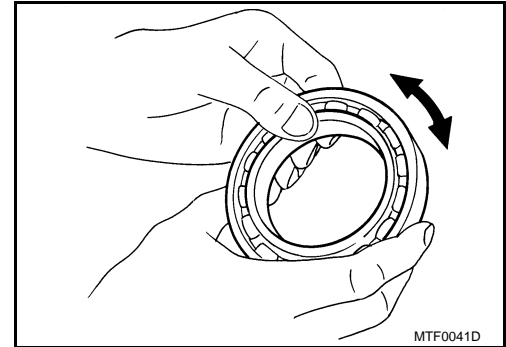

## ASSEMBLY

1. Press in reverse main gear using Tools.

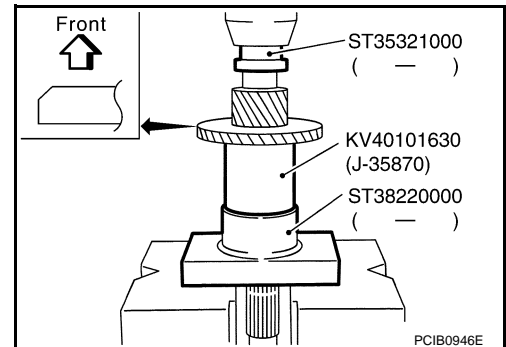

### CAUTION:

- Be careful with orientation of reverse main gear.
- Do not reuse reverse main gear.

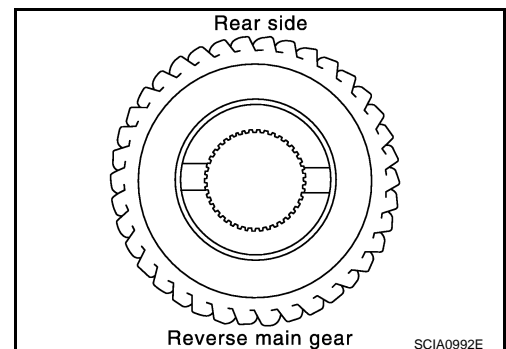

# MAINSHAFT AND GEARS

[RS6F52A]

## < SERVICE INFORMATION >

2. Press in 1st main gear bushing using Tools.
3. Install 1st needle bearing and then 1st main gear.

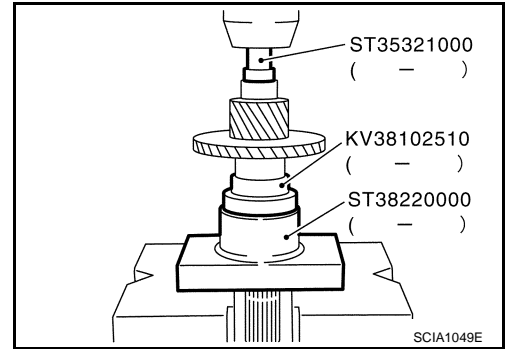

4. Install 1st-2nd spread springs, 1st-2nd shifting inserts, and 1st-2nd synchronizer hub onto 1st-2nd coupling sleeve.

**CAUTION:**

- Be careful with orientation of 1st-2nd synchronizer hub.
- Do not reuse 1st-2nd synchronizer hub and 1st-2nd coupling sleeve.
- Replace 1st-2nd synchronizer hub and 1st-2nd coupling sleeve as a set.

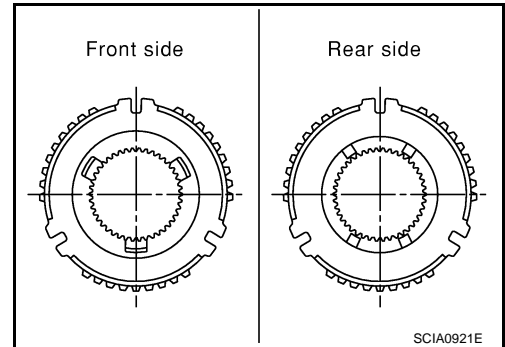

- Be careful with orientation of 1st-2nd coupling sleeve.

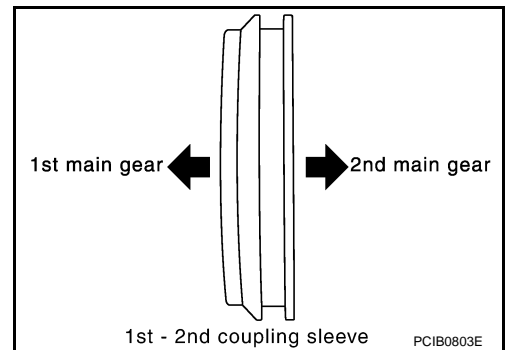

- Be sure not to hook center projection of 2 spread springs on same 1st-2nd shifting insert.

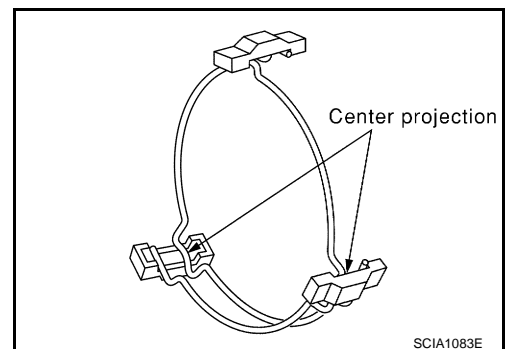

A  
B  
MT  
D  
E  
F  
G  
H  
I  
J  
K  
L  
M  
N  
O  
P

# MAINSHAFT AND GEARS

[RS6F52A]

< SERVICE INFORMATION >

- Install 1st inner baulk ring, 1st synchronizer cone, and 1st outer baulk ring onto mainshaft and then press in 1st-2nd synchronizer hub assembly onto mainshaft using Tools.

**CAUTION:**

- Outer baulk ring, synchronizer cone, and inner baulk ring on 2nd gear-side must have been removed.
- Be careful with orientation of coupling sleeve.
- Replace 1st inner baulk ring, 1st synchronizer cone, and 1st outer baulk ring as a set.

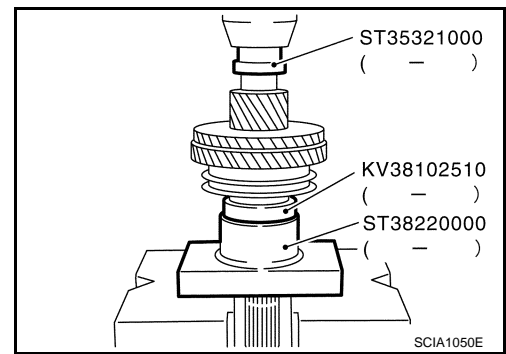

- Press in 2nd main gear bushing using Tools.
- Install 2nd outer baulk ring, 2nd synchronizer cone, and 2nd inner baulk ring.

**CAUTION:**

- Replace 2nd outer baulk ring, 2nd synchronizer cone, and 2nd inner baulk ring as a set.

- Install 2nd needle bearing and 2nd main gear.

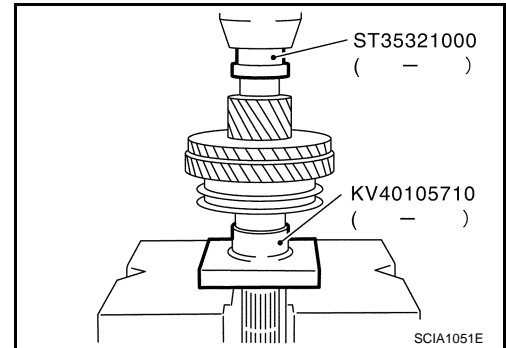

- Press in 3rd main gear using Tools.

**CAUTION:**

- Be careful with orientation of 3rd main gear.
- Do not reuse 3rd main gear.

- Install 3rd-4th mainshaft spacer.

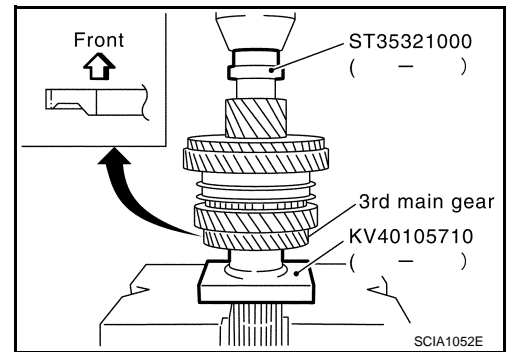

- Select 4th main gear adjusting shim so that dimension "C1" satisfies the standard value below and install 4th main gear adjusting shim onto mainshaft. Refer to [MT-125, "Available Adjusting Shims"](#).

**Standard value for dimension "C1"**

**: Refer to [MT-125, "Available Adjusting Shims"](#).**

**CAUTION:**

**Only one adjusting shim can be selected.**

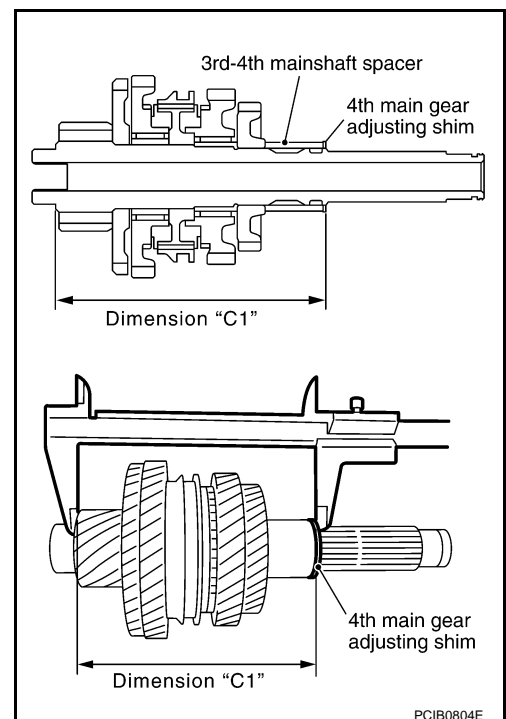

# MAINSHAFT AND GEARS

[RS6F52A]

< SERVICE INFORMATION >

12. Press in 4th main gear using Tools.

**CAUTION:**

- Be careful with orientation of 4th main gear.
- Do not reuse 4th main gear.

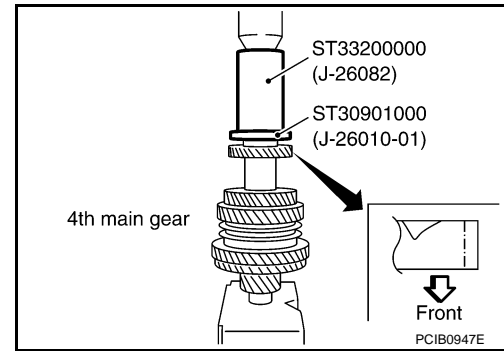

13. Press in 5th main gear using Tools.

**CAUTION:**

- Be careful with orientation of 5th main gear.
- Do not reuse 5th main gear.

14. Install 5th-6th mainshaft spacer.

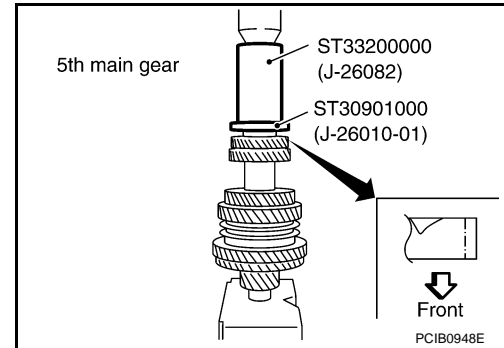

15. Press in 6th main gear using Tools (A), (B).

- Tool number**      **A: ST33200000 (J-26082)**  
                              **B: ST30901000 (J-26010-01)**

**CAUTION:**

**Do not reuse 6th main gear.**

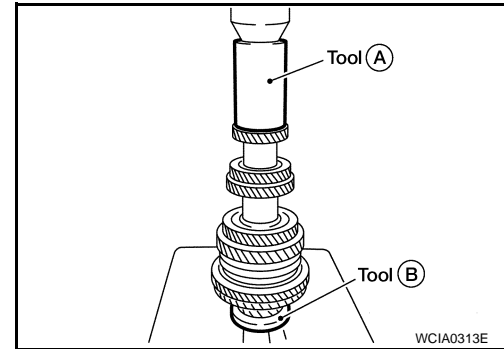

16. Select 6th main gear adjusting shim and then install it onto mainshaft.

- Calculate thickness "S" of 6th main gear adjusting shim following the procedure below so that end play dimension between 6th main gear and mainshaft rear bearing becomes the dimension shown below. Refer to [MT-125. "Available Adjusting Shims"](#).

**End play** :Refer to [MT-125. "Available Adjusting Shims"](#).

**Dimension "S" = (S1 - S2) - End play**

**S** : Thickness of adjusting shim

**S1** : Dimension from mainshaft standard face to mainshaft rear bearing press-fit end face

**S2** : Dimension from mainshaft standard face to 6th main gear end face

**CAUTION:**

**Only one adjusting shim can be selected.**

- Measure dimension "S1" and "S2" using a height gauge (A) and pick tester (B).
- Install selected 6th main gear adjusting shim to mainshaft.

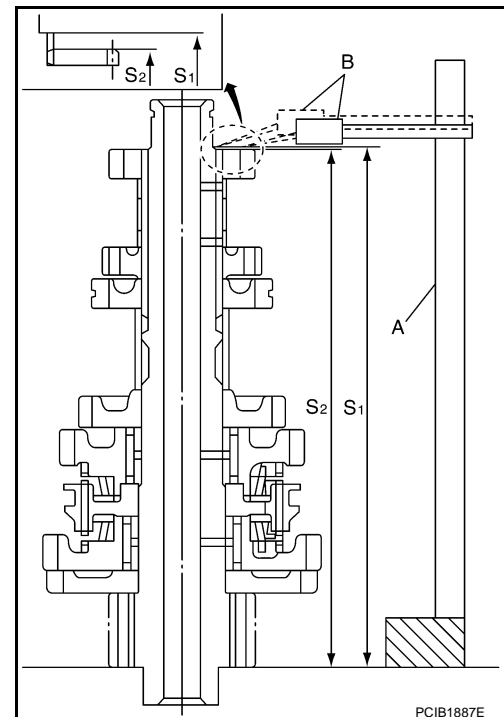

A  
B  
MT  
D  
E  
F  
G  
H  
I  
J  
K  
L  
M  
N  
O  
P

# MAINSHAFT AND GEARS

[RS6F52A]

< SERVICE INFORMATION >

17. Press in mainshaft rear bearing using Tools (A), (B).

**Tool number**      **A: ST30720000 (J-25405)**  
                             **B: ST30901000 (J-26010-01)**

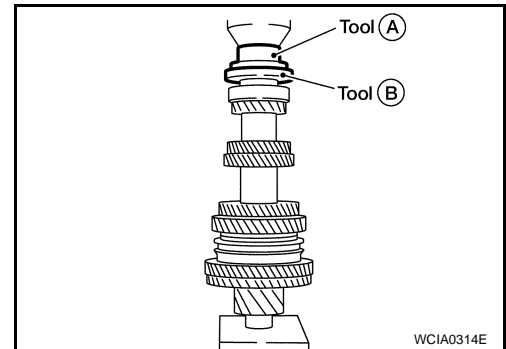

18. Install mainshaft C-rings onto mainshaft and check that end play of mainshaft rear bearing satisfies the standard value.

**End play standard value**

**: Refer to [MT-124, "Available C-Rings"](#).**

- If measurement is outside the standard range, reselect mainshaft C-rings. Refer to [MT-124, "Available C-Rings"](#).

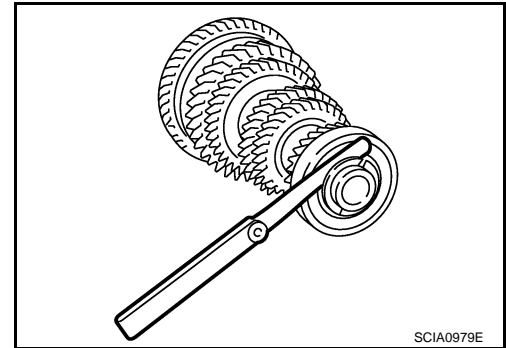

19. Install C-ring holder and then install snap ring.

**CAUTION:**

**Do not reuse snap ring.**

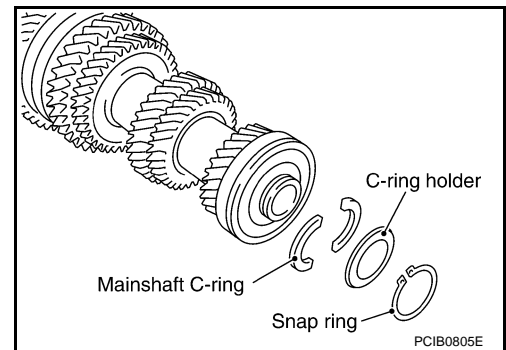

20. Check end play of 1st and 2nd main gears.

**End play standard value**

**: Refer to [MT-123, "Gear End Play"](#).**

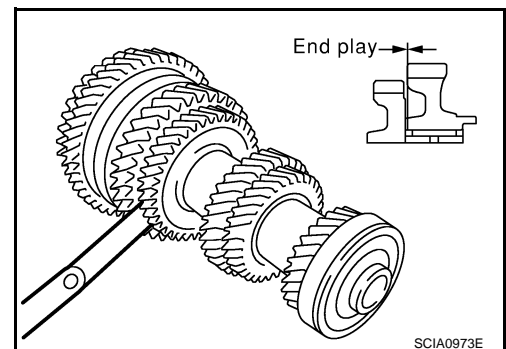



# REVERSE IDLER SHAFT AND GEARS

< SERVICE INFORMATION >

[RS6F52A]

## REVERSE IDLER SHAFT AND GEARS

### Disassembly and Assembly

INFOID:000000001850889

#### DISASSEMBLY

1. Remove reverse idler gear (rear), reverse coupling sleeve, and reverse insert springs simultaneously.
2. Remove reverse idler gear needle bearing.
3. Remove thrust needle bearing.
4. Remove reverse baulk ring.
5. Remove reverse idler gear (front).
6. Remove reverse idler gear needle bearing.
7. Remove thrust needle bearing.
8. Remove retaining pin from reverse idler shaft.

#### INSPECTION AFTER DISASSEMBLY

##### Reverse Idler Shaft and Gears

Check items below. If necessary, replace them with new ones.

- Damage, peeling, dent, uneven wear, bending, and other non-standard conditions of the shaft.
- Excessive wear, damage, peeling, and other non-standard conditions of the gears.

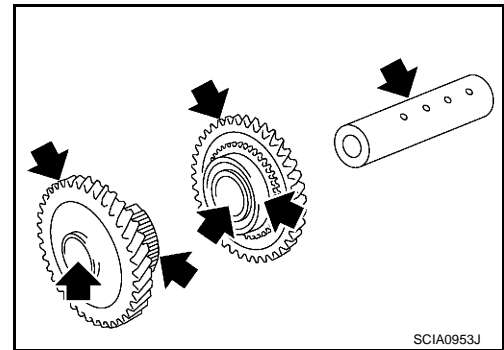

##### Synchronizer

Check items below. If necessary, replace them with new ones.

- Damage and unusual wear on contact surfaces of coupling sleeve, synchronizer hub of reverse idler gear (rear), and insert spring.
- Coupling sleeve and synchronizer hub of reverse idler gear (rear) must move smoothly.

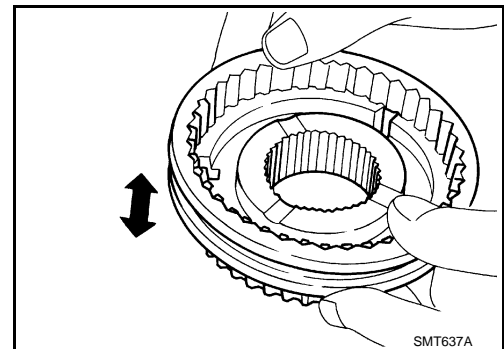

- If any crack, damage, or excessive wear is found on cam face of baulk ring or working face of insert, replace it.

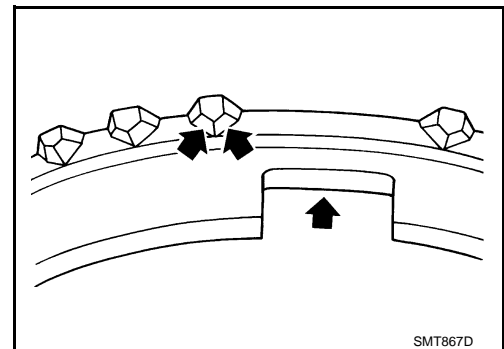

#### BAULK RING CLEARANCE

A  
B  
MT  
D  
E  
F  
G  
H  
I  
J  
K  
L  
M  
N  
O  
P

# REVERSE IDLER SHAFT AND GEARS

[RS6F52A]

## < SERVICE INFORMATION >

- Push baulk ring on the cone and measure the clearance between baulk ring and cone. If the measurement is below limit, replace it with a new one.

### Clearance

**Standard value** : Refer to [MT-123, "Baulk Ring Clearance"](#).

**Limit value** : Refer to [MT-123, "Baulk Ring Clearance"](#).

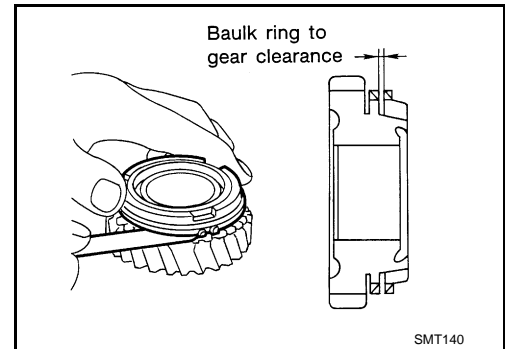

### Bearing

Check items below. If necessary, replace them with new ones.

- Damage and rough rotation of bearing.

## ASSEMBLY

Note the following, and assemble in the reverse order of disassembly.

### CAUTION:

- **Be careful with orientation of reverse insert spring.**

⇐ : Front

- **Never reuse retaining pin.**

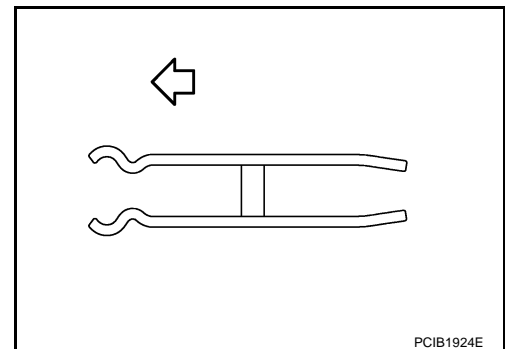

## FINAL DRIVE

### Disassembly and Assembly

INFOID:000000001850890

#### PRE-INSPECTION

- Check the clearance between side gear and differential case as follows.
1. Clean final drive assembly sufficiently to prevent side gear thrust washer, differential case, side gear, and other parts from sticking by gear oil.
  2. Put differential case vertically so that side gear to be measured faces upward.
  3. Place Tool and a dial indicator onto side gear.

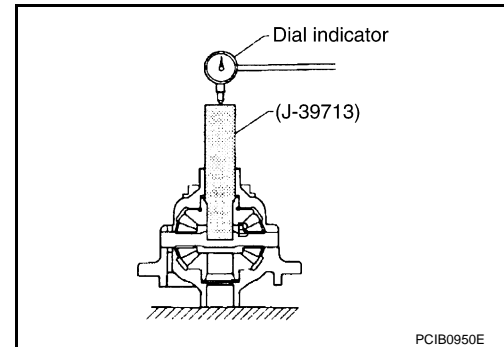

4. Move side gear up and down, and measure the clearance.

**Allowable Clearance between side gear and differential case with thrust washer**

: Refer to [MT-124, "Available Thrust Washer"](#).

**CAUTION:**

**There should be no resistance and gears should rotate freely.**

5. If not within specification, adjust the clearance by changing side gear thrust washer thickness.
6. Turn differential case upside down and measure the clearance between side gear and differential case on the other side in the same way.

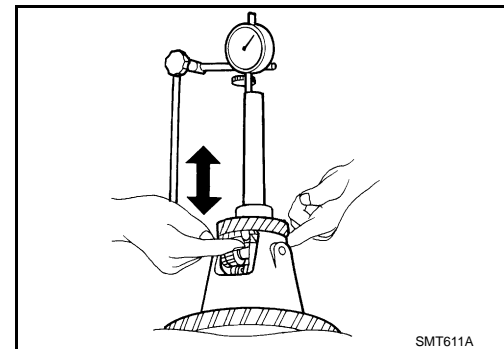

#### DISASSEMBLY

1. Remove final gear bolts and then separate the final gear from differential case.
2. Remove differential side bearing (clutch housing side) using Tool and pullers (B).

**Tool number     A: ST33061000 (J-8107-2)**

**CAUTION:**

**Hook a puller on the cage of differential side bearing.**

3. Remove speedometer drive gear.

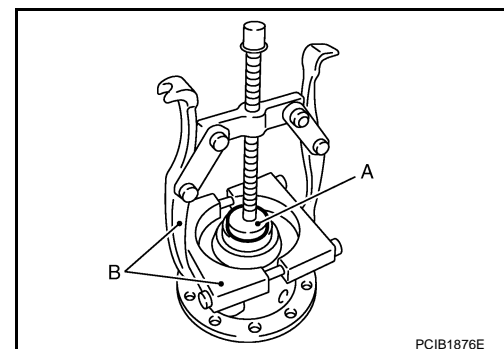

# FINAL DRIVE

[RS6F52A]

## < SERVICE INFORMATION >

4. Remove differential side bearing (transaxle case side) using Tool and puller.

**CAUTION:**

Hook a puller on the inner race of differential side bearing.

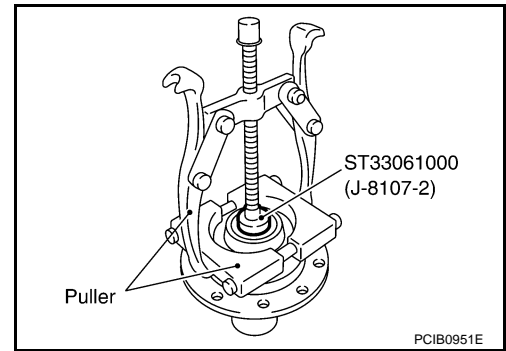

5. Remove retaining pin from differential case using suitable tool and then remove pinion mate shaft.
6. Rotate pinion mate gears and remove pinion mate gears, pinion mate thrust washers, side gears, and side gear thrust washers from differential case.

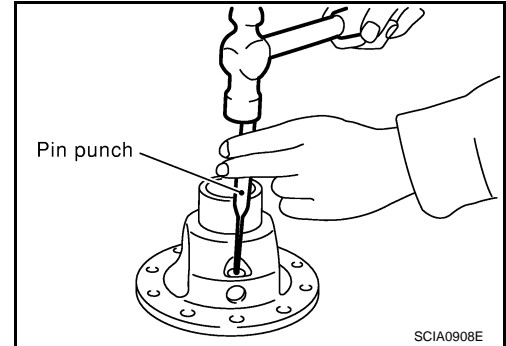

## INSPECTION AFTER DISASSEMBLY

### Gear, Washer, Shaft and Case

- Check side gears, side gear thrust washers, pinion mate shaft, pinion mate gears, pinion mate thrust washers and differential case. If necessary, replace with a new one.

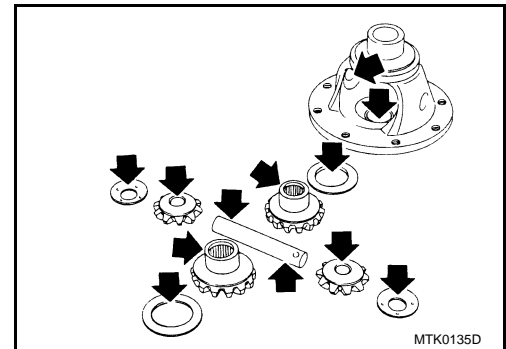

### Bearing

- Check for bearings damage and rough rotation. If necessary, replace with a new one.

**CAUTION:**

When replacing tapered roller bearing, replace outer and inner races as a set.

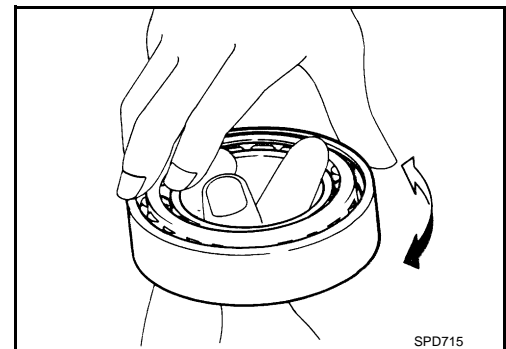

## ASSEMBLY

1. Apply gear oil to sliding area of differential case, each gear, and thrust washer.

# FINAL DRIVE

[RS6F52A]

## < SERVICE INFORMATION >

2. Install side gear thrust washers and side gears into differential case.
3. While rotating pinion mate thrust washers and pinion mate gears, aligning them diagonally, install them into differential case.

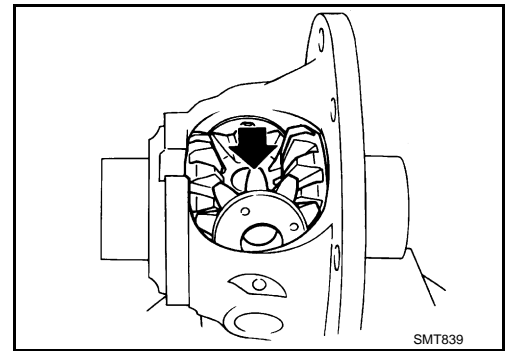

4. Insert pinion mate shaft into differential case.  
**CAUTION:**  
**Be sure not to damage pinion mate thrust washers.**

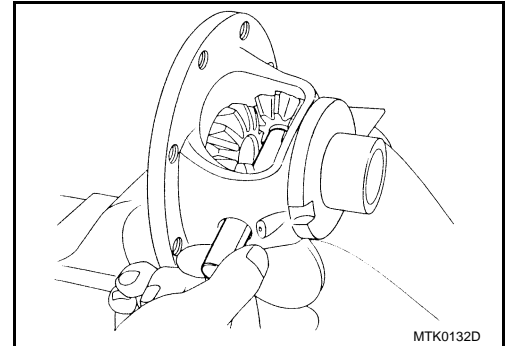

5. Measure end play of side gears following the procedure below. Then select side gear thrust washer.
  - a. Put differential case vertically so that its side gear to be measured faces upward.
  - b. Place the preload adapter and a dial indicator onto side gears.

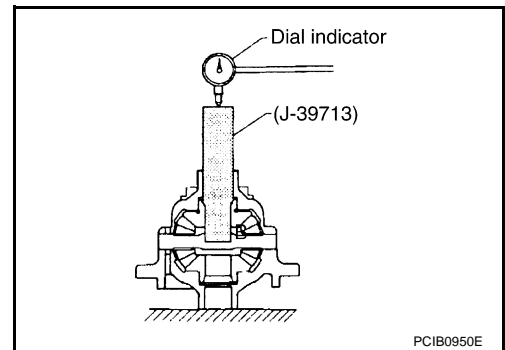

- c. Move side gears up and down to measure the clearance and select thrust washer so that it satisfies the standard value. Refer to [MT-124, "Available Thrust Washer"](#).

**Allowable Clearance between side gear and differential case with thrust washer**

**: Refer to [MT-124, "Available Thrust Washer"](#).**

### **CAUTION:**

- There should be no resistance and gears should rotate freely.
- Place differential case upside down. Measure the end play for opposite side-gears likewise securely.
- Only one thrust washer can be selected.

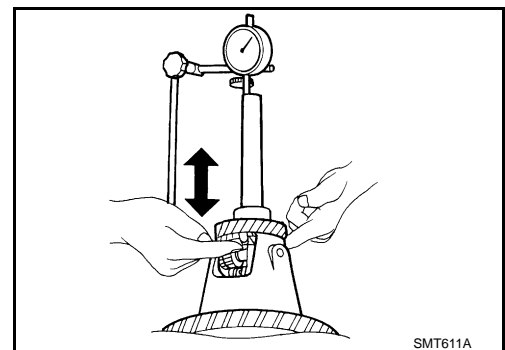

A  
B  
MT  
D  
E  
F  
G  
H  
I  
J  
K  
L  
M  
N  
O  
P

# FINAL DRIVE

[RS6F52A]

## < SERVICE INFORMATION >

6. Install retaining pin into pinion mate shaft using suitable tool.

**CAUTION:**  
Never reuse retaining pin.

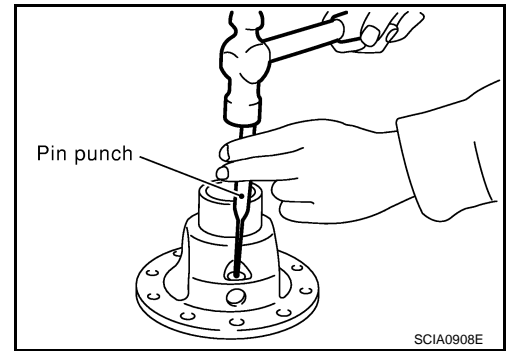

7. Press in differential side bearing (transaxle case side) to differential case using Tools.

**CAUTION:**  
Replace differential side bearing and differential side bearing outer race as a set.

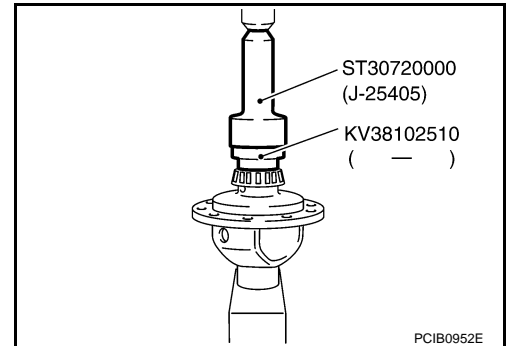

8. Align and install speedometer drive gear onto differential case.

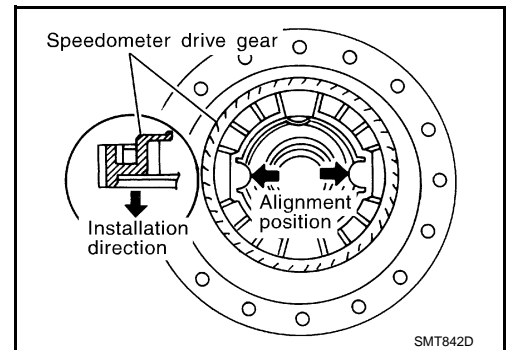

9. Press in differential side bearing (clutch housing side) to differential case using Tools (A), (B).

**Tool number**      **A: ST30720000 (J-25405)**  
                             **B: KV38102510 ( — )**

**CAUTION:**

- Never reuse differential side bearing and differential side bearing outer race.
- Replace differential side bearing and differential side bearing outer race as a set.

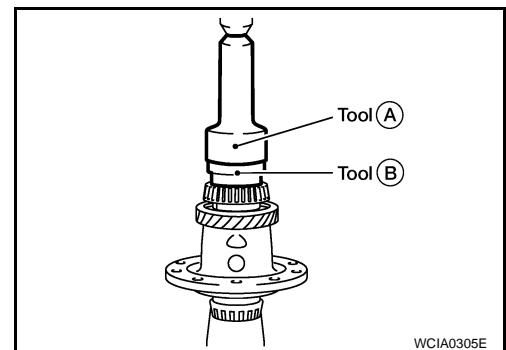

10. Install final gear into differential case and tighten final gear bolts to the specified torque. Refer to [MT-68. "Disassembly and Assembly"](#).

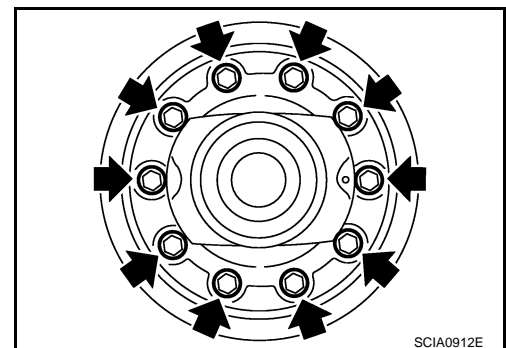

## SHIFT CONTROL

### Disassembly and Assembly

INFOID:000000001850891

#### DISASSEMBLY

1. Remove return spring to striking rod assembly.

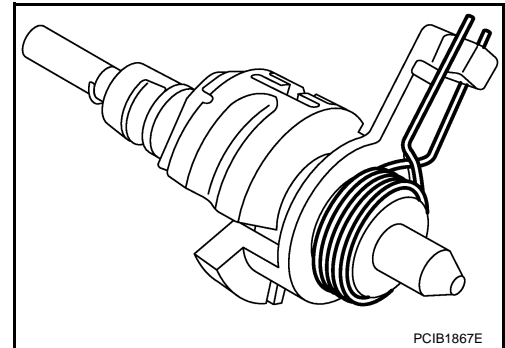

#### INSPECTION AFTER DISASSEMBLY

##### Striking Rod Assembly and Return Spring

- Check contact surfaces and sliding area for wear, damage, bending, etc. If necessary, replace parts.

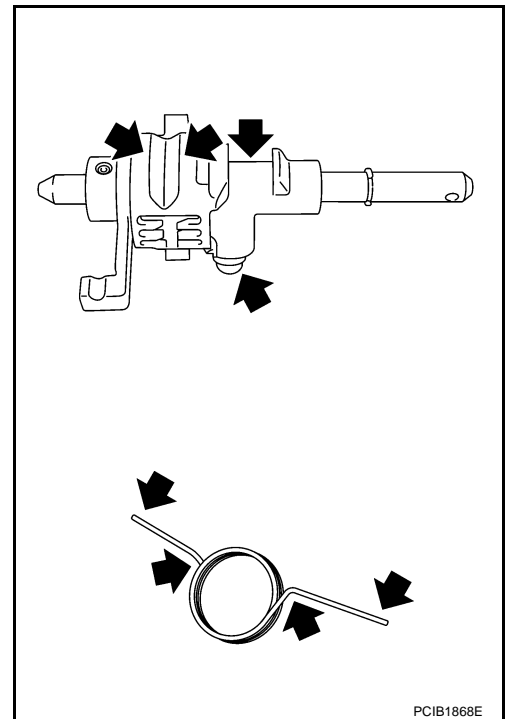

##### Fork Rod and Shift Fork

A  
B  
MT  
D  
E  
F  
G  
H  
I  
J  
K  
L  
M  
N  
O  
P

# SHIFT CONTROL

[RS6F52A]

## < SERVICE INFORMATION >

- Check contact surfaces and sliding area for wear, damage, bending, etc. If necessary, replace parts.

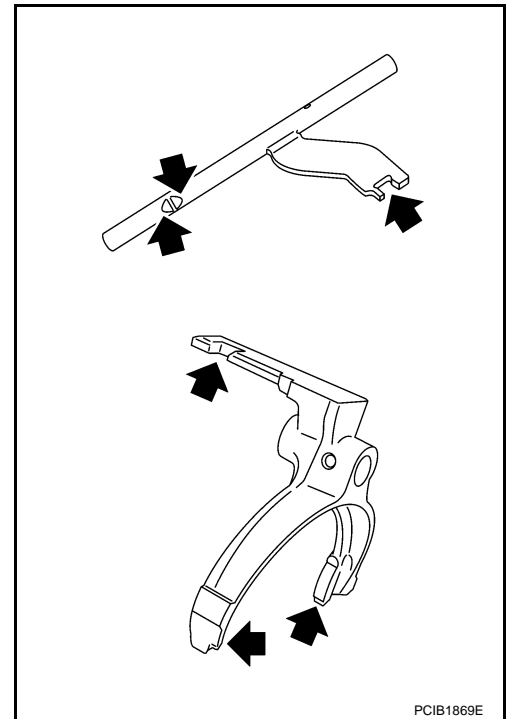

- Check if the width of shift fork hook (sliding area with coupling sleeve) is within allowable specification below.

Item	One-side wear specification	Sliding width of new part
1st-2nd	0.2 mm (0.008 in)	7.80 - 7.93 mm (0.3071 - 0.3122 in)
3rd-4th	0.2 mm (0.008 in)	7.80 - 7.93 mm (0.3071 - 0.3122 in)
5th-6th	0.2 mm (0.008 in)	6.10 - 6.23 mm (0.2402 - 0.2453 in)
Reverse	0.2 mm (0.008 in)	12.80 - 12.93 mm (0.5039 - 0.5091 in)

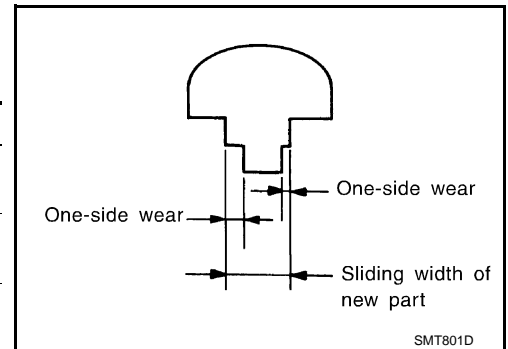

## ASSEMBLY

1. Temporarily install return spring to striking rod assembly.

**CAUTION:**

**Be careful with the orientation of return spring.**

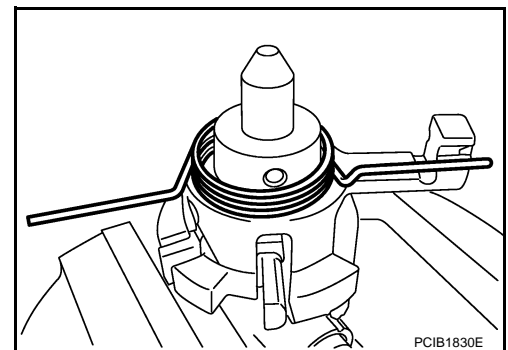



# SHIFT CONTROL

[RS6F52A]

## < SERVICE INFORMATION >

2. Attach one end of the return spring to striking interlock of striking rod assembly while holding return spring.

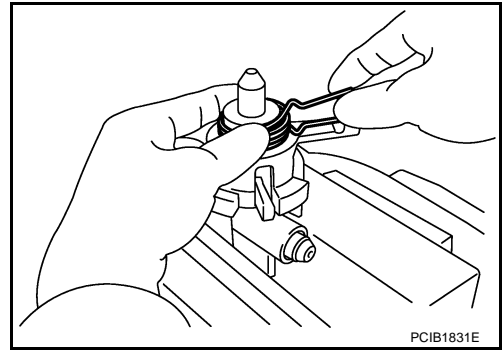

### CAUTION:

- When installing, check that return spring is securely seated in the groove of striking interlock of striking rod assembly.

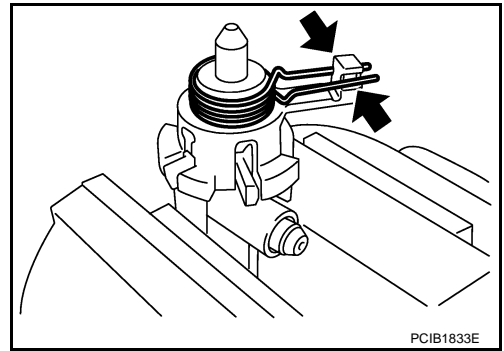

A  
B  
MT  
D  
E  
F  
G  
H  
I  
J  
K  
L  
M  
N  
O  
P

# SERVICE DATA AND SPECIFICATIONS (SDS)

< SERVICE INFORMATION >

[RS6F52A]

## SERVICE DATA AND SPECIFICATIONS (SDS)

### General Specification

INFOID:000000001850892

#### TRANSAXLE

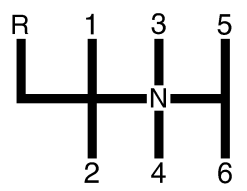
Engine type		QR25DE	
Transaxle model		RS6F52A	
Model code number		ET80D	
Number of speed		6	
Synchromesh type		Warner	
Shift pattern		 <p style="text-align: right; font-size: small;">PCIB1769E</p>	
Gear ratio	1st	3.153	
	2nd	1.950	
	3rd	1.392	
	4th	1.055	
	5th	0.809	
	6th	0.630	
	Reverse	3.002	
Number of teeth	Input gear	1st	13
		2nd	20
		3rd	28
		4th	36
		5th	42
		6th	46
		Reverse	13
	Main gear	1st	41
		2nd	39
		3rd	39
		4th	38
		5th	34
		6th	29
		Reverse	38
	Reverse idler gear	Front	37
Rear		38	
Oil level	mm (in)	61.0 - 67.0 (2.402 - 2.638)	
Oil capacity (Reference)	ℓ (US pt, Imp pt)	1.7 (3-5/8, 3)	
Remarks	Reverse synchronizer	Installed	
	Double-cone synchronizer	3rd	
	Triple-cone synchronizer	1st and 2nd	

#### FINAL GEAR

# SERVICE DATA AND SPECIFICATIONS (SDS)

< SERVICE INFORMATION >

[RS6F52A]

Engine type	QR25DE	
Transaxle model	RS6F52A	
Model code number	ET80D	
Final gear ratio	4.428	
Number of teeth	Final gear/Pinion	62/14
	Side gear/Pinion mate gear	14/10

## Gear End Play

INFOID:000000001850893

Unit: mm (in)

Gear	Standard value
1st main gear	0.20 - 0.30 (0.0079 - 0.0118)
2nd main gear	0.06 - 0.16 (0.0024 - 0.0063)
3rd input gear	0.18 - 0.31 (0.0071 - 0.0122)
4th input gear	0.20 - 0.30 (0.0079 - 0.0118)
5th input gear	0.06 - 0.16 (0.0024 - 0.0063)
6th input gear	0.06 - 0.16 (0.0024 - 0.0063)

## Baulk Ring Clearance

INFOID:000000001850894

Unit: mm (in)

Measurement point	Standard value	Limit value	
3rd (Double-cone synchronizer)	Clearance between synchronizer cone and inner baulk ring end face "A"	0.6 - 0.8 (0.024 - 0.031)	0.2 (0.008)
	Clearance between outer baulk ring pawl and synchronizer cone "B"	0.6 - 1.1 (0.024 - 0.043)	0.2 (0.008)
1st and 2nd (Triple-cone synchronizer)	Clearance between synchronizer cone and clutch gear end face "A"	0.6 - 1.2 (0.024 - 0.047)	0.3 (0.012)
	Clearance between outer baulk ring pawl and synchronizer cone "B"	0.6 - 1.1 (0.024 - 0.043)	0.2 (0.008)
	Clearance between inner baulk ring and clutch gear end face "C"	0.7 - 1.1 (0.028 - 0.043)	0.3 (0.012)
4th		0.9 - 1.45 (0.035 - 0.057)	0.7 (0.028)
5th		0.95 - 1.4 (0.037 - 0.055)	0.7 (0.028)
6th		0.95 - 1.4 (0.037 - 0.055)	0.7 (0.028)
Reverse		0.95 - 1.4 (0.037 - 0.055)	0.7 (0.028)

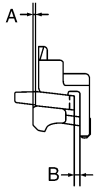

PCIB0249E

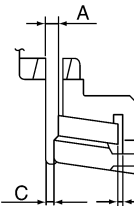

PCIB0835J

## Available Snap Rings

INFOID:000000001850895

## 6TH INPUT GEAR BUSHING

# SERVICE DATA AND SPECIFICATIONS (SDS)

< SERVICE INFORMATION >

[RS6F52A]

End play standard value		0 - 0.1 mm (0 - 0.004 in)	
Thickness mm (in)	Part number*	Thickness mm (in)	Part number*
1.76 (0.0693)	32204 8H511	2.01 (0.0791)	32204 8H516
1.81 (0.0713)	32204 8H512	2.06 (0.0811)	32204 8H517
1.86 (0.0732)	32204 8H513	2.11 (0.0831)	32204 8H518
1.91 (0.0752)	32204 8H514	2.16 (0.0850)	32204 8H519
1.96 (0.0772)	32204 8H515	2.21 (0.0870)	32204 8H520

\*: Always check with the Parts Department for the latest parts information.

## Available C-Rings

INFOID:000000001850896

### MAINSHAFT C-RING

End play standard value		0 - 0.06 mm (0 - 0.0024 in)	
Thickness mm (in)	Part number*	Thickness mm (in)	Part number*
2.535 (0.0998)	32348 8H800	2.835 (0.1116)	32348 8H810
2.565 (0.1010)	32348 8H801	2.865 (0.1128)	32348 8H811
2.595 (0.1022)	32348 8H802	2.895 (0.1140)	32348 8H812
2.625 (0.1033)	32348 8H803	2.925 (0.1152)	32348 8H813
2.655 (0.1045)	32348 8H804	2.955 (0.1163)	32348 8H814
2.685 (0.1057)	32348 8H805	2.985 (0.1175)	32348 8H815
2.715 (0.1069)	32348 8H806	3.015 (0.1187)	32348 8H816
2.745 (0.1081)	32348 8H807	3.045 (0.1199)	32348 8H817
2.775 (0.1093)	32348 8H808	3.075 (0.1211)	32348 8H818
2.805 (0.1104)	32348 8H809		

\*: Always check with the Parts Department for the latest parts information.

## Available Thrust Washer

INFOID:000000001850897

### INPUT SHAFT THRUST WASHER

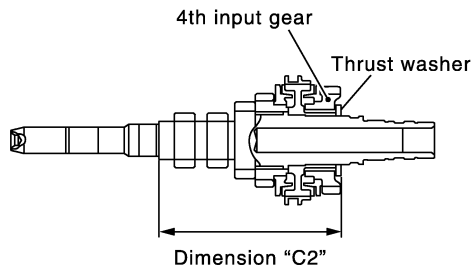

SCIA1008E

Standard value for dimension "C2"		154.7 - 154.8 mm (6.091 - 6.094 in)	
Thickness mm (in)	Part number*	Thickness mm (in)	Part number*
3.84 (0.1512)	32347 8H500	4.02 (0.1583)	32347 8H503
3.90 (0.1535)	32347 8H501	4.08 (0.1606)	32347 8H504
3.96 (0.1559)	32347 8H502	4.14 (0.1630)	32347 8H505

\*: Always check with the Parts Department for the latest parts information.

### DIFFERENTIAL SIDE GEAR THRUST WASHER

Allowable Clearance between side gear and differential case with thrust washer	0.1 - 0.2 mm (0.004 - 0.008 in)

# SERVICE DATA AND SPECIFICATIONS (SDS)

< SERVICE INFORMATION >

[RS6F52A]

Thickness mm (in)	Part number*
0.75 (0.0295)	38424 81X00
0.80 (0.0315)	38424 81X01
0.85 (0.0335)	38424 81X02
0.90 (0.0354)	38424 81X03
0.95 (0.0374)	38424 81X04

\*: Always check with the Parts Department for the latest parts information.

## Available Adjusting Shims

INFOID:000000001850898

### 4TH MAIN GEAR ADJUSTING SHIM

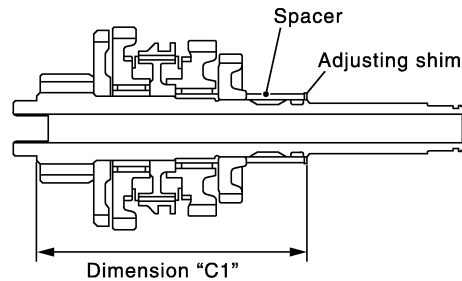

SCIA1009E

Standard value for dimension "C1"		173.85 - 173.95 mm (6.844 - 6.848 in)	
Thickness mm (in)	Part number*	Thickness mm (in)	Part number*
0.52 (0.0205)	32238 8H500	0.84 (0.0331)	32238 8H504
0.60 (0.0236)	32238 8H501	0.92 (0.0362)	32238 8H505
0.68 (0.0268)	32238 8H502	1.00 (0.0394)	32238 8H506
0.76 (0.0299)	32238 8H503	1.08 (0.0425)	32238 8H507

\*: Always check with the Parts Department for the latest parts information.

### INPUT SHAFT REAR BEARING ADJUSTING SHIM

End play standard value			0 - 0.06 mm (0 - 0.0024 in)		
Thickness mm (in)	Part number*	Thickness mm (in)	Part number*	Thickness mm (in)	Part number*
0.40 (0.0157)	32225 8H500	0.88 (0.0346)	32225 8H512	1.36 (0.0535)	32225 8H524
0.44 (0.0173)	32225 8H501	0.92 (0.0362)	32225 8H513	1.40 (0.0551)	32225 8H560
0.48 (0.0189)	32225 8H502	0.96 (0.0378)	32225 8H514	1.44 (0.0567)	32225 8H561
0.52 (0.0205)	32225 8H503	1.00 (0.0394)	32225 8H515	1.48 (0.0583)	32225 8H562
0.56 (0.0220)	32225 8H504	1.04 (0.0409)	32225 8H516	1.52 (0.0598)	32225 8H563
0.60 (0.0236)	32225 8H505	1.08 (0.0425)	32225 8H517	1.56 (0.0614)	32225 8H564
0.64 (0.0252)	32225 8H506	1.12 (0.0441)	32225 8H518	1.60 (0.0630)	32225 8H565
0.68 (0.0268)	32225 8H507	1.16 (0.0457)	32225 8H519	1.64 (0.0646)	32225 8H566
0.72 (0.0283)	32225 8H508	1.20 (0.0472)	32225 8H520		
0.76 (0.0299)	32225 8H509	1.24 (0.0488)	32225 8H521		
0.80 (0.0315)	32225 8H510	1.28 (0.0504)	32225 8H522		
0.84 (0.0331)	32225 8H511	1.32 (0.0520)	32225 8H523		

\*: Always check with the Parts Department for the latest parts information.

### MAINSHAFT REAR BEARING ADJUSTING SHIM

# SERVICE DATA AND SPECIFICATIONS (SDS)

< SERVICE INFORMATION >

[RS6F52A]

End play standard value		0 - 0.06 mm (0 - 0.0024 in)	
Thickness mm (in)	Part number*	Thickness mm (in)	Part number*
0.44 (0.0173)	32238 8H510	0.80 (0.0315)	32238 8H519
0.48 (0.0189)	32238 8H511	0.84 (0.0331)	32238 8H520
0.52 (0.0205)	32238 8H512	0.88 (0.0346)	32238 8H521
0.56 (0.0220)	32238 8H513	0.92 (0.0362)	32238 8H522
0.60 (0.0236)	32238 8H514	0.96 (0.0378)	32238 8H523
0.64 (0.0252)	32238 8H515	1.00 (0.0394)	32238 8H524
0.68 (0.0268)	32238 8H516	1.04 (0.0409)	32238 8H560
0.72 (0.0283)	32238 8H517	1.08 (0.0425)	32238 8H561
0.76 (0.0299)	32238 8H518		

\*: Always check with the Parts Department for the latest parts information.

## REVERSE IDLER GEAR ADJUSTING SHIM

End play standard value		0.04 - 0.10 mm (0.0016 - 0.0039 in)	
Thickness mm (in)	Part number*	Thickness mm (in)	Part number*
1.76 (0.0693)	32237 8H800	2.24 (0.0882)	32237 8H812
1.80 (0.0709)	32237 8H801	2.28 (0.0898)	32237 8H813
1.84 (0.0724)	32237 8H802	2.32 (0.0913)	32237 8H814
1.88 (0.0740)	32237 8H803	2.36 (0.0929)	32237 8H815
1.92 (0.0756)	32237 8H804	2.40 (0.0945)	32237 8H816
1.96 (0.0772)	32237 8H805	2.44 (0.0961)	32237 8H817
2.00 (0.0787)	32237 8H806	2.48 (0.0976)	32237 8H818
2.04 (0.0803)	32237 8H807	2.52 (0.0992)	32237 8H819
2.08 (0.0819)	32237 8H808	2.56 (0.1008)	32237 8H820
2.12 (0.0835)	32237 8H809	2.60 (0.1024)	32237 8H821
2.16 (0.0850)	32237 8H810	2.64 (0.1039)	32237 8H822
2.20 (0.0866)	32237 8H811		

\*: Always check with the Parts Department for the latest parts information.

## 6TH MAIN GEAR ADJUSTING SHIM

End play standard value		0 - 0.1 mm (0 - 0.004 in)	
Thickness mm (in)	Part number*	Thickness mm (in)	Part number*
0.88 (0.0346)	32237 8H560	1.20 (0.0472)	32237 8H564
0.96 (0.0378)	32237 8H561	1.28 (0.0504)	32237 8H565
1.04 (0.0409)	32237 8H562	1.36 (0.0535)	32237 8H566
1.12 (0.0441)	32237 8H563		

\*: Always check with the Parts Department for the latest parts information.

## STRIKING ROD ADJUSTING SHIM

End play standard value		0.05 - 0.152 mm (0.0020 - 0.0060 in)	
Thickness mm (in)	Part number*	Thickness mm (in)	Part number*
1.12 (0.0441)	33761 JA60A	1.52 (0.0598)	33761 JA65A
1.20 (0.0472)	33761 JA61A	1.60 (0.0630)	33761 JA66A
1.28 (0.0504)	33761 JA62A	1.68 (0.0661)	33761 JA67A
1.36 (0.0535)	33761 JA63A	1.76 (0.0693)	33761 JA68A
1.44 (0.0567)	33761 JA64A	1.84 (0.0724)	33761 JA69A

\*: Always check with the Parts Department for the latest parts information.

## Available Shims

INFOID:000000001850899

### — Differential Side Bearing Preload and Adjusting Shim

#### BEARING PRELOAD

Differential side bearing preload: L*	0.15 - 0.21 mm (0.0059 - 0.0083 in)
---------------------------------------	-------------------------------------

# SERVICE DATA AND SPECIFICATIONS (SDS)

[RS6F52A]

## < SERVICE INFORMATION >

\*: Install shims which are "deflection of differential case" + "L" in thickness.

### DIFFERENTIAL SIDE BEARING ADJUSTING SHIM(S)

Thickness mm (in)	Part number*	Thickness mm (in)	Part number*
0.48 (0.0189)	31438 80X00	0.72 (0.0283)	31438 80X06
0.52 (0.0205)	31438 80X01	0.76 (0.0299)	31438 80X07
0.56 (0.0220)	31438 80X02	0.80 (0.0315)	31438 80X08
0.60 (0.0236)	31438 80X03	0.84 (0.0331)	31438 80X09
0.64 (0.0252)	31438 80X04	0.88 (0.0346)	31438 80X10
0.68 (0.0268)	31438 80X05	0.92 (0.0362)	31438 80X11

\*: Always check with the Parts Department for the latest parts information.

A

B

MT

D

E

F

G

H

I

J

K

L

M

N

O

P

## SERVICE INFORMATION

### PRECAUTIONS

#### Precaution for Supplemental Restraint System (SRS) "AIR BAG" and "SEAT BELT PRE-TENSIONER"

INFOID:000000001850900

The Supplemental Restraint System such as "AIR BAG" and "SEAT BELT PRE-TENSIONER", used along with a front seat belt, helps to reduce the risk or severity of injury to the driver and front passenger for certain types of collision. This system includes seat belt switch inputs and dual stage front air bag modules. The SRS system uses the seat belt switches to determine the front air bag deployment, and may only deploy one front air bag, depending on the severity of a collision and whether the front occupants are belted or unbelted. Information necessary to service the system safely is included in the SRS and SB section of this Service Manual.

**WARNING:**

- To avoid rendering the SRS inoperative, which could increase the risk of personal injury or death in the event of a collision which would result in air bag inflation, all maintenance must be performed by an authorized NISSAN/INFINITI dealer.
- Improper maintenance, including incorrect removal and installation of the SRS, can lead to personal injury caused by unintentional activation of the system. For removal of Spiral Cable and Air Bag Module, see the SRS section.
- Do not use electrical test equipment on any circuit related to the SRS unless instructed to in this Service Manual. SRS wiring harnesses can be identified by yellow and/or orange harnesses or harness connectors.

#### Service Notice or Precaution

INFOID:000000001850901

- Do not reuse transaxle oil, once it has been drained.
- Check oil level or replace oil with vehicle on level surface.
- During removal or installation, keep inside of transaxle clear of dust or dirt.
- Check for the correct installation status prior to removal or disassembly. If matching marks are required, be certain they do not interfere with the function of the parts they are applied.
- In principle, tighten bolts or nuts gradually in several steps working diagonally from inside to outside. If tightening sequence is specified, use it.
- Be careful not to damage sliding surfaces and mating surfaces.



# PREPARATION

< SERVICE INFORMATION >

[RS6F52H]

## PREPARATION

### Special Service Tool

INFOID:000000001850902

The actual shapes of Kent-Moore tools may differ from those of special service tools illustrated here.

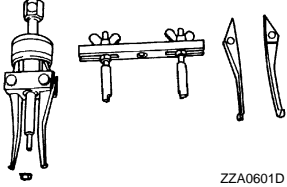
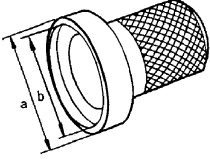
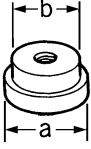
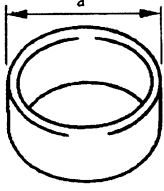
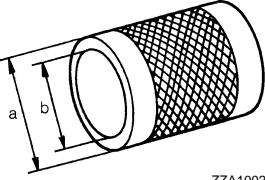
Tool number (Kent-Moore No.) Tool name	Description
KV381054S0 (J-34286) Puller   ZZA0601D	<ul style="list-style-type: none"> <li>• Removing differential side bearing outer race (clutch housing side)</li> <li>• Removing differential side bearing outer race (transaxle case side)</li> <li>• Removing mainshaft front bearing</li> </ul>
ST33400001 (J-26082) Drift   ZZA0814D	Installing differential side oil seal (clutch housing side) <b>a: 60 mm (2.36 in) dia.</b> <b>b: 47 mm (1.85 in) dia.</b>
ST35321000 ( — ) Drift   ZZA1000D	<ul style="list-style-type: none"> <li>• Installing input shaft oil seal</li> <li>• Installing reverse main gear</li> <li>• Installing 1st main gear bushing</li> <li>• Installing 1st-2nd synchronizer hub assembly</li> <li>• Installing 2nd main gear bushing</li> <li>• Installing 3rd main gear</li> </ul> <b>a: 49 mm (1.93 in) dia.</b> <b>b: 41 mm (1.61 in) dia.</b>
KV40105320 ( — ) Drift   ZZA0898D	Installing differential side bearing outer race (clutch housing side) <b>a: 88 mm (3.46 in) dia.</b>
ST33200000 (J-26082) Drift   ZZA1002D	<ul style="list-style-type: none"> <li>• Installing mainshaft front bearing</li> <li>• Installing 6th input gear bushing</li> <li>• Installing 4th main gear</li> <li>• Installing 5th main gear</li> <li>• Installing 6th main gear</li> </ul> <b>a: 60 mm (2.36 in) dia.</b> <b>b: 44.5 mm (1.752 in) dia.</b>

A  
B  
MT  
D  
E  
F  
G  
H  
I  
J  
K  
L  
M  
N  
O  
P

# PREPARATION

< SERVICE INFORMATION >

[RS6F52H]

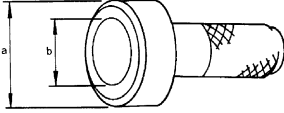
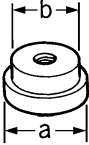
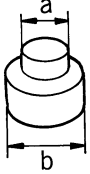
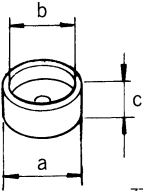
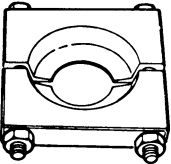
Tool number (Kent-Moore No.) Tool name		Description
ST30720000 (J-25405) Drift	 <p style="text-align: center; font-size: small;">ZZA0811D</p>	<ul style="list-style-type: none"> <li>• Installing differential side oil seal (transaxle case side)</li> <li>• Installing differential side bearing outer race (clutch housing side)</li> <li>• Installing differential side bearing outer race (transaxle case side)</li> <li>• Installing mainshaft rear bearing</li> <li>• Installing differential side bearing (clutch housing side)</li> <li>• Installing differential side bearing (transaxle case side)</li> </ul> <p><b>a: 77 mm (3.03 in) dia.</b> <b>b: 55.5 mm (2.185 in) dia.</b></p>
ST33061000 (J-8107-2) Drift	 <p style="text-align: center; font-size: small;">ZZA1000D</p>	<ul style="list-style-type: none"> <li>• Installing bore plug</li> <li>• Removing differential side bearing (transaxle case side)</li> <li>• Removing differential side bearing (clutch housing side)</li> </ul> <p><b>a: 38 mm (1.50 in) dia.</b> <b>b: 28.5 mm (1.122 in) dia.</b></p>
ST33052000 ( — ) Drift	 <p style="text-align: center; font-size: small;">ZZA1023D</p>	<ul style="list-style-type: none"> <li>• Removing input shaft rear bearing</li> <li>• Removing 6th input gear, 6th input gear bushing, 5th-6th synchronizer hub assembly, and 5th input gear</li> <li>• Removing 5th input gear bushing, 4th input gear, 4th input gear bushing, 3rd-4th synchronizer hub assembly, and 3rd input gear</li> <li>• Installing input shaft front bearing</li> <li>• Removing mainshaft rear bearing</li> <li>• Removing 6th main gear</li> <li>• Removing 4th main gear and 5th main gear</li> </ul> <p><b>a: 22 mm (0.87 in) dia.</b> <b>b: 28 mm (1.10 in) dia.</b></p>
KV40105020 ( — ) Drift	 <p style="text-align: center; font-size: small;">ZZA1133D</p>	Removing 3rd main gear, 2nd main gear, 2nd main gear bushing, 1st-2nd synchronizer hub assembly, 1st main gear, 1st main gear bushing, and reverse main gear <p><b>a: 39.7 mm (1.563 in) dia.</b> <b>b: 35 mm (1.38 in) dia.</b> <b>c: 15 mm (0.59 in)</b></p>
ST30031000 (J-22912-01) Puller	 <p style="text-align: center; font-size: small;">ZZA0537D</p>	Measuring wear of inner baulk ring

# PREPARATION

< SERVICE INFORMATION >

[RS6F52H]

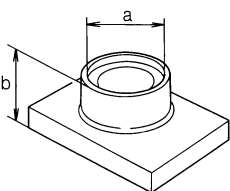
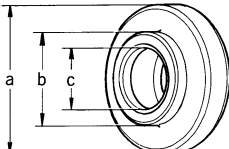
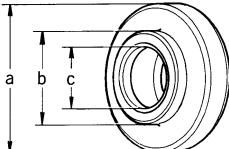
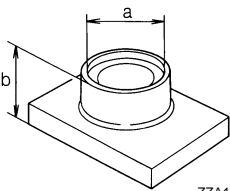
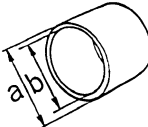
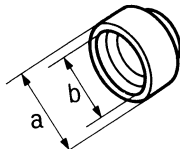
Tool number (Kent-Moore No.) Tool name	Description	
KV40105710 ( — ) Press stand  ZZA1058D	<ul style="list-style-type: none"> <li>• Installing 3rd-4th synchronizer hub assembly</li> <li>• Installing 4th input gear bushing</li> <li>• Installing 5th input gear bushing</li> <li>• Installing 5th-6th synchronizer hub assembly</li> <li>• Installing 2nd main gear bushing</li> <li>• Installing 3rd main gear</li> </ul> <b>a: 46 mm (1.81 in) dia.</b> <b>b: 41 mm (1.61 in)</b>	A B MT D
ST30901000 (J-26010-01) Drift  ZZA0978D	<ul style="list-style-type: none"> <li>• Installing input shaft rear bearing</li> <li>• Installing 4th main gear</li> <li>• Installing 5th main gear</li> <li>• Installing 6th main gear</li> <li>• Installing mainshaft rear bearing</li> </ul> <b>a: 79 mm (3.11 in) dia.</b> <b>b: 45 mm (1.77 in) dia.</b> <b>c: 35.2 mm (1.386 in) dia.</b>	E F
ST30032000 (J-26010-01) Drift  ZZA0978D	Installing input shaft front bearing <b>a: 80 mm (3.15 in) dia.</b> <b>b: 38 mm (1.50 in) dia.</b> <b>c: 31 mm (1.22 in) dia.</b>	G H
ST38220000 ( — ) Press stand  ZZA1058D	<ul style="list-style-type: none"> <li>• Installing reverse main gear</li> <li>• Installing 1st main gear bushing</li> <li>• Installing 1st-2nd synchronizer hub assembly</li> </ul> <b>a: 63 mm (2.48 in) dia.</b> <b>b: 65 mm (2.56 in)</b>	I J K
KV40101630 (J-35870) Drift  ZZA1003D	Installing reverse main gear <b>a: 68 mm (2.68 in) dia.</b> <b>b: 60 mm (2.36 in) dia.</b>	L M
KV38102510 ( — ) Drift  ZZA0838D	<ul style="list-style-type: none"> <li>• Installing 1st main gear bushing</li> <li>• Installing 1st-2nd synchronizer hub assembly</li> <li>• Installing differential side bearing (transaxle case side)</li> <li>• Installing differential side bearing (clutch housing side)</li> </ul> <b>a: 71 mm (2.80 in) dia.</b> <b>b: 65 mm (2.56 in) dia.</b>	N O P

# PREPARATION

< SERVICE INFORMATION >

[RS6F52H]

## Commercial Service Tool

INFOID:000000001850903

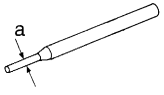
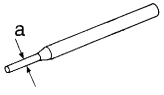
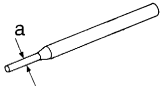
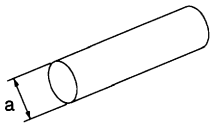
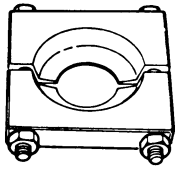
Tool name	Description
<p>Pin punch</p>  <p style="text-align: right;">NT410</p>	<p>Removing and installing retaining pin  <b>a: 4.5 mm (0.177 in) dia.</b></p>
<p>Pin punch</p>  <p style="text-align: right;">NT410</p>	<p>Removing and installing retaining pin of selector lever  <b>a: 5.5 mm (0.217 in) dia.</b></p>
<p>Pin punch</p>  <p style="text-align: right;">NT410</p>	<p>Removing and installing retaining pin of each shifter lever  <b>a: 7.5 mm (0.295 in) dia.</b></p>
<p>Drift</p>  <p style="text-align: right;">S-NT063</p>	<p>Installing striking rod oil seal and shifter lever oil seal  <b>a: 24.5 mm (0.965 in) dia.</b></p>
<p>Puller</p>  <p style="text-align: right;">ZZA0537D</p>	<p>Removing each bearing, gear, and bushing</p>

# PREPARATION

< SERVICE INFORMATION >

[RS6F52H]

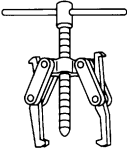
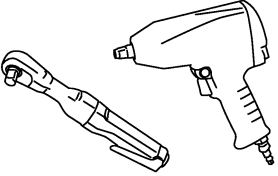
Tool name	Description
<p>Puller</p> <div style="text-align: center;">  <p>NT077</p> </div>	<p>Removing each bearing, gear, and bushing</p>
<p>Power tool</p> <div style="text-align: center;">  <p>PBIC0190E</p> </div>	<p>Loosening bolts and nuts</p>

A  
B  
**MT**  
D  
E  
F  
G  
H  
I  
J  
K  
L  
M  
N  
O  
P

# NOISE, VIBRATION AND HARSHNESS (NVH) TROUBLESHOOTING

< SERVICE INFORMATION >

[RS6F52H]

## NOISE, VIBRATION AND HARSHNESS (NVH) TROUBLESHOOTING

### NVH Troubleshooting Chart

INFOID:000000001850904

Use the chart below to help you find the cause of the symptom. The numbers indicate the order of the inspection. If necessary, repair or replace these parts.

Reference page		<a href="#">MT-13Z</a>			<a href="#">MT-144</a>		<a href="#">MT-140</a>		<a href="#">MT-144</a>		<a href="#">MT-144</a>		
SUSPECTED PARTS (Possible cause)		OIL (Oil level is low.)	OIL (Wrong oil.)	OIL (Oil level is high.)	GASKET (Damaged)	OIL SEAL (Worn or damaged)	SHIFT CONTROL LINKAGE (Worn)	STRIKING ROD ASSEMBLY (Worn or damaged)	SHIFT FORK (Worn)	GEAR (Worn or damaged)	BEARING (Worn or damaged)	BAULK RING (Worn or damaged)	INSERT SPRING (Damaged)
Symptoms	Noise	1	2							3	3		
	Oil leakage		3	1	2	2							
	Hard to shift or will not shift		1	1			2					3	3
	Jumps out of gear						1	2	3	3			

# DESCRIPTION

< SERVICE INFORMATION >

[RS6F52H]

## DESCRIPTION

### Cross-Sectional View

INFOID:000000001850905

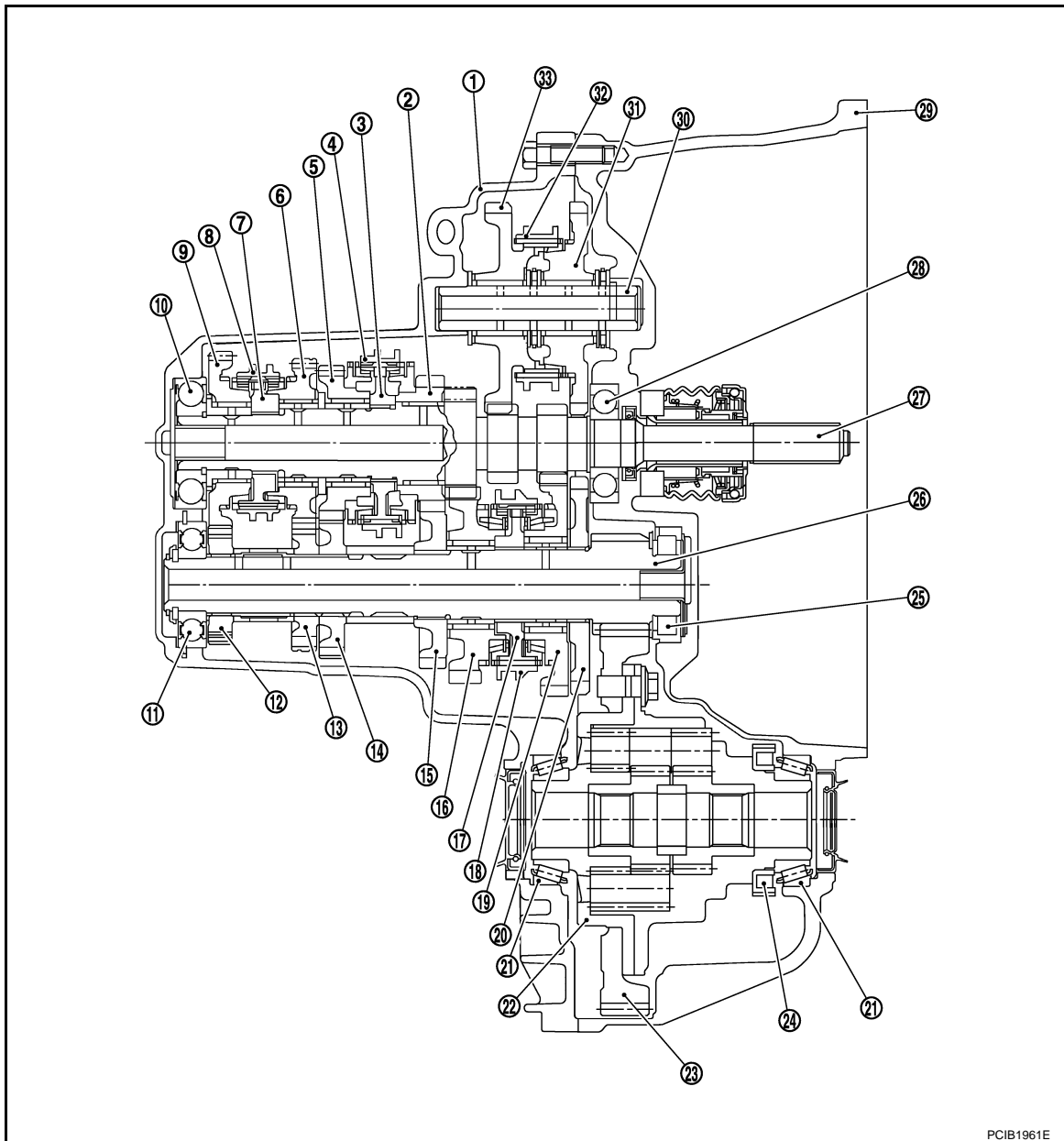

PCIB1961E

- |                                |                              |                               |
|--------------------------------|------------------------------|-------------------------------|
| 1. Transaxle case              | 2. 3rd input gear            | 3. 3rd-4th synchronizer hub   |
| 4. 3rd-4th coupling sleeve     | 5. 4th input gear            | 6. 5th input gear             |
| 7. 5th-6th synchronizer hub    | 8. 5th-6th coupling sleeve   | 9. 6th input gear             |
| 10. Input shaft rear bearing   | 11. Mainshaft rear bearing   | 12. 6th main gear             |
| 13. 5th main gear              | 14. 4th main gear            | 15. 3rd main gear             |
| 16. 2nd main gear              | 17. 1st-2nd synchronizer hub | 18. 1st-2nd coupling sleeve   |
| 19. 1st main gear              | 20. Reverse main gear        | 21. Differential side bearing |
| 22. Differential case assembly | 23. Final gear               | 24. Speedometer drive gear    |
| 25. Mainshaft front bearing    | 26. Mainshaft                | 27. Input shaft               |
| 28. Input shaft front bearing  | 29. Clutch housing           | 30. Reverse idler shaft       |
| 31. Reverse idler gear (front) | 32. Reverse coupling sleeve  | 33. Reverse idler gear (rear) |

### DOUBLE-CONE SYNCHRONIZER

**MT-135**

A

B

MT

D

E

F

G

H

I

J

K

L

M

N

O

P

# DESCRIPTION

< SERVICE INFORMATION >

[RS6F52H]

Double-cone synchronizer is adopted for 3rd gear to reduce operating force of the control lever.

## TRIPLE-CONE SYNCHRONIZER

Triple-cone synchronizer are adopted for 1st and 2nd gears to reduce operating force of the control lever.

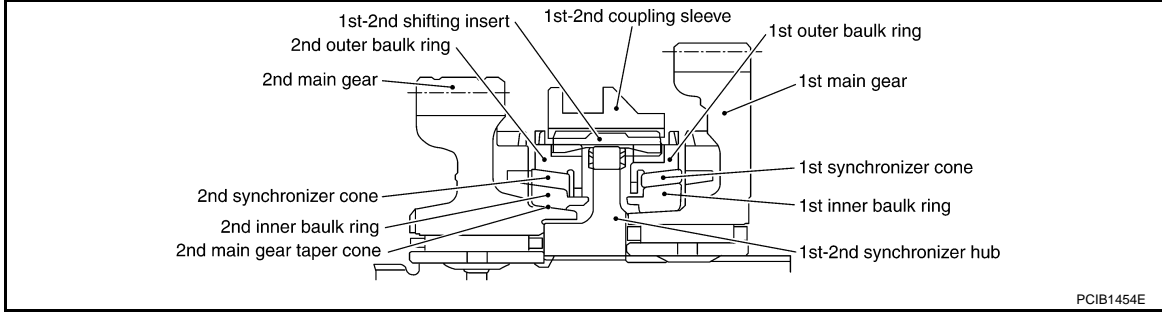

## REVERSE GEAR NOISE PREVENTION FUNCTION (SYNCHRONIZING METHOD)

Reverse gear can be matched smoothly in a structure by setting synchronizer hub (1) of reverse idler gear (rear), reverse coupling sleeve (2), reverse baulk ring (3), and reverse insert spring (4) to reverse idler gears, and letting reverse gear be synchronized.

- 5 : Reverse idler gear (rear)
- 6 : Reverse idler gear (front)

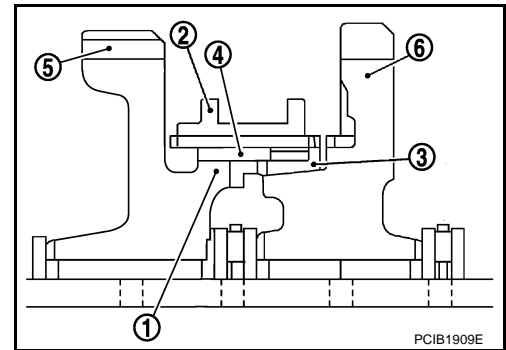



## M/T OIL

## Changing M/T Oil

INFOID:000000001850906

## DRAINING

1. Start engine and let it run to warm up transaxle.
2. Stop engine. Remove transaxle drain plug and drain oil.
3. Set a gasket on drain plug and install it to transaxle. Tighten drain plug to the specified torque. Refer to [MT-144, "Disassembly and Assembly"](#).

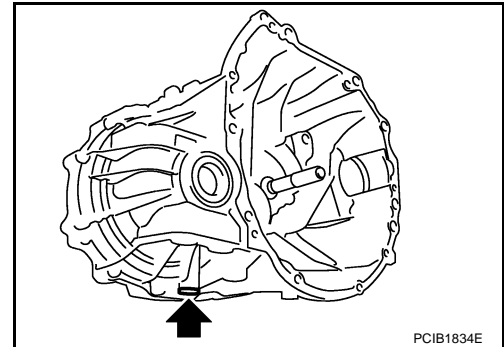
**CAUTION:****Do not reuse gasket.**

## FILLING

1. Remove plug (with ABS models) (1) or speedometer pinion gear (without ABS models) (1). Fill the transaxle with new oil and check the oil level "L" using suitable gauge (A) as shown.

**Oil grade and capacity** : Refer to [MA-13, "QR25DE"](#).

**Oil level "L"** : 61.0 - 67.0 mm (2.402 - 2.638 in)

2. Set an O-ring on plug (with ABS models) (1) or speedometer pinion gear (without ABS models) (1) and then install it to transaxle. Tighten to the specified torque. Refer to [MT-144, "Disassembly and Assembly"](#).

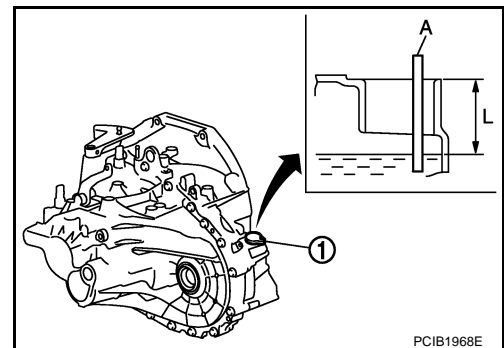
**CAUTION:****Do not reuse O-ring.**

## Checking M/T Oil

INFOID:000000001850907

## OIL LEAKAGE AND OIL LEVEL

1. Make sure that oil is not leaking from transaxle or around it.
2. Remove plug (with ABS models) (1) or speedometer pinion gear (without ABS models) (1).
3. Check the oil level "L" using suitable gauge (A) as shown.

**Oil level "L"** : 61.0 - 67.0 mm (2.402 - 2.638 in)

**CAUTION:****Do not start engine while checking oil level.**

4. Set an O-ring on plug (with ABS models) (1) or speedometer pinion gear (without ABS models) (1) and then install it to transaxle. Tighten to the specified torque. Refer to [MT-144, "Disassembly and Assembly"](#).

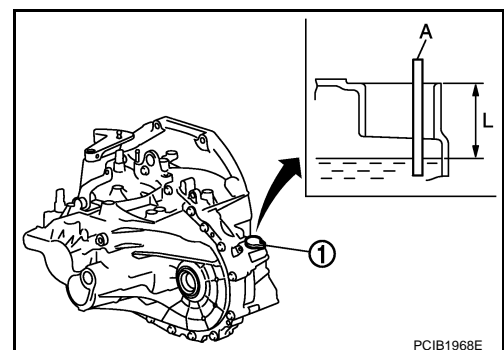
**CAUTION:****Do not reuse O-ring.**

## SIDE OIL SEAL

### Removal and Installation

INFOID:000000001850908

#### REMOVAL

1. Remove front drive shafts from transaxle assembly. Refer to [FAX-8, "Removal and Installation \(Left Side\)"](#) and [FAX-10, "Removal and Installation \(Right Side\)"](#).
2. Remove differential side oil seal (1) using a suitable tool.  
**CAUTION:**  
**Do not damage transaxle case and clutch housing.**

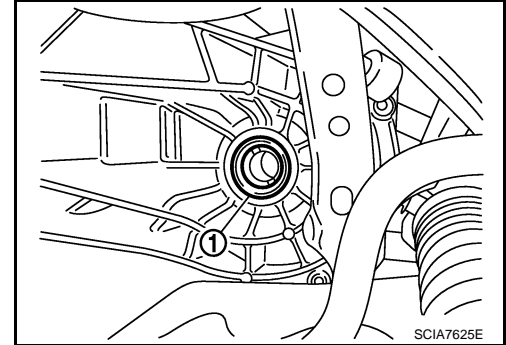

#### INSTALLATION

Installation is in the reverse order of removal.

- Install differential side oil seal to clutch housing and transaxle case to the specified dimension "A" using Tools.

**Dimension "A"** : -0.5 - 0.5 mm (-0.020 - 0.020 in)

**Tool numbers** : ST30720000 (J-25405)  
 : ST33400001 (J-26082)

**CAUTION:**

**Do not reuse oil seal.**

- Check oil level after installation. Refer to [MT-137, "Checking M/T Oil"](#).

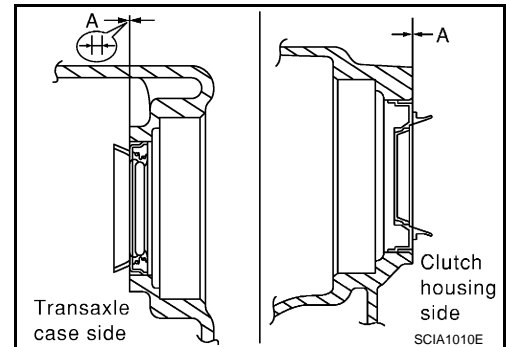

# POSITION SWITCH

[RS6F52H]

< SERVICE INFORMATION >

## POSITION SWITCH

### Checking

INFOID:000000001850909

#### NOTE:

For removal and installation of the switches, refer to [MT-144. "Disassembly and Assembly"](#).

#### BACK-UP LAMP SWITCH

- Check continuity.

Gear position	Continuity
Reverse	Yes
Except reverse	No

- 1 : Park/Neutral position (PNP) switch
- 2 : Back-up lamp switch

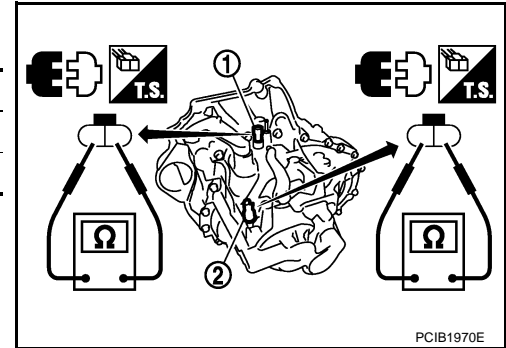

#### PARK/NEUTRAL POSITION (PNP) SWITCH

- Check continuity.

Gear position	Continuity
Neutral	Yes
Except neutral	No

A  
B  
MT  
D  
E  
F  
G  
H  
I  
J  
K  
L  
M  
N  
O  
P

# CONTROL LINKAGE

< SERVICE INFORMATION >

[RS6F52H]

## CONTROL LINKAGE

### Component of Control Device and Cable

INFOID:000000001850910

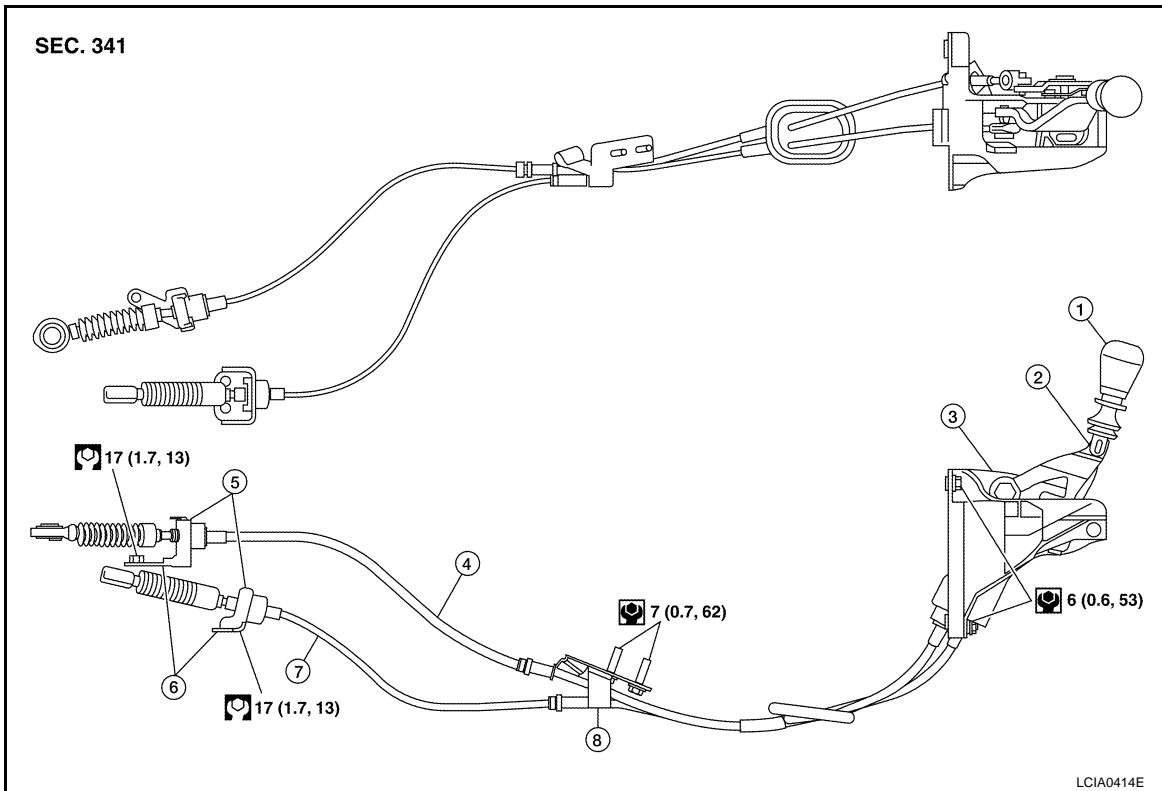

- |                       |                          |                            |
|-----------------------|--------------------------|----------------------------|
| 1. Control lever knob | 2. Control lever         | 3. Control device assembly |
| 4. Select cable       | 5. Lock plate            | 6. Cable bracket           |
| 7. Shift cable        | 8. Cable support bracket |                            |

### Removal and Installation

INFOID:000000001850911

#### REMOVAL

1. Remove battery. Refer to [SC-7, "Removal and Installation QR25DE"](#).
2. Remove air cleaner and air duct. Refer to [EM-127, "Removal and Installation"](#).
3. Remove shift cable from shifter lever as shown.

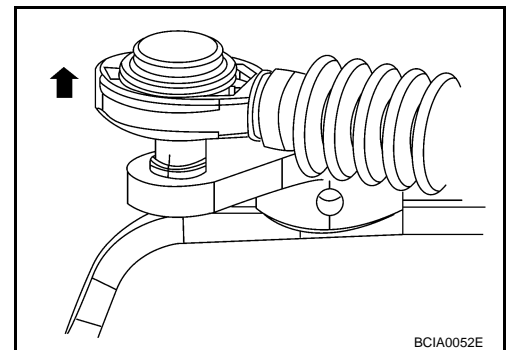

# CONTROL LINKAGE

[RS6F52H]

## < SERVICE INFORMATION >

4. Remove select cable from selector lever A as shown.

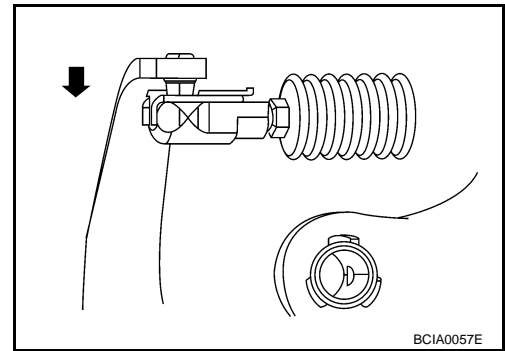

5. Shift control lever to neutral position.
6. Remove control lever knob.
7. Remove center console assembly. Refer to [IP-11, "Removal and Installation"](#).
8. Remove control device assembly nuts.
9. Remove exhaust front tube, center muffler and heat shield. Refer to [EX-6, "Removal and Installation"](#).
10. Remove cable support bracket.
11. Remove select cable and shift cable from cable bracket.
12. Remove control device assembly from the vehicle.

## INSTALLATION

Installation is in the reverse order of removal.

- Securely install each cable to shifter lever and selector lever.
- Be careful about the installation direction, and screw control lever knob onto control lever.

⇐: Front

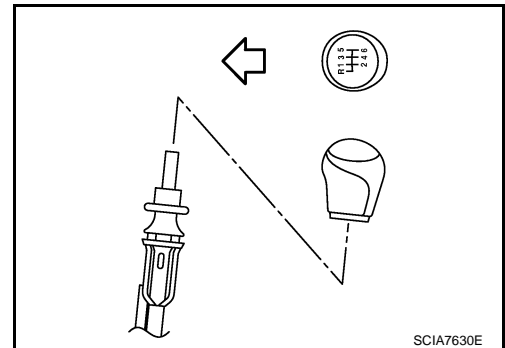

- When control lever is selected to 1st-2nd side and 5th-6th side, confirm control lever returns to neutral position smoothly.
- When control lever is shifted to each position, make sure there is no binding or disconnection in each boot.

# AIR BREATHER HOSE

< SERVICE INFORMATION >

[RS6F52H]

## AIR BREATHER HOSE

### Removal and Installation

INFOID:000000001850912

Refer to the figure for air breather hose removal and installation information.

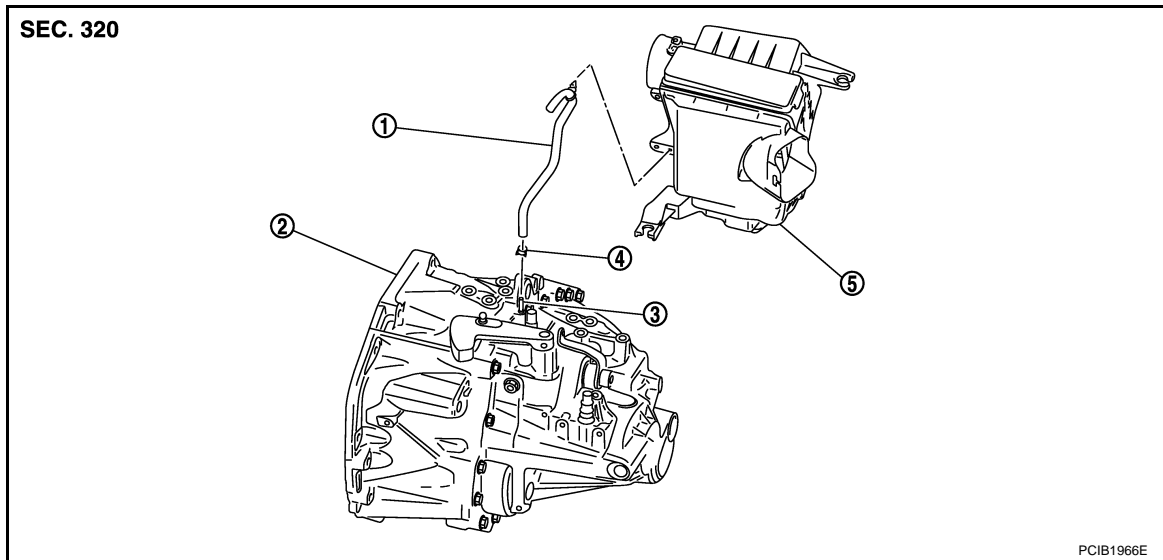

- |                      |                       |                      |
|----------------------|-----------------------|----------------------|
| 1. Air breather hose | 2. Transaxle assembly | 3. Air breather tube |
| 4. Clamp             | 5. Air cleaner case   |                      |

#### **CAUTION:**

- Make sure there are no pinched or restricted areas on the air breather hose caused by bending or winding when installing it.
- Be sure to insert air breather hose into air breather tube until hose end reaches the tube's base.
- Set air breather hose with painted mark facing forward.
- Install air breather hose to air cleaner case by fully inserting the clip.

## TRANSAXLE ASSEMBLY

### Component

INFOID:000000001850913

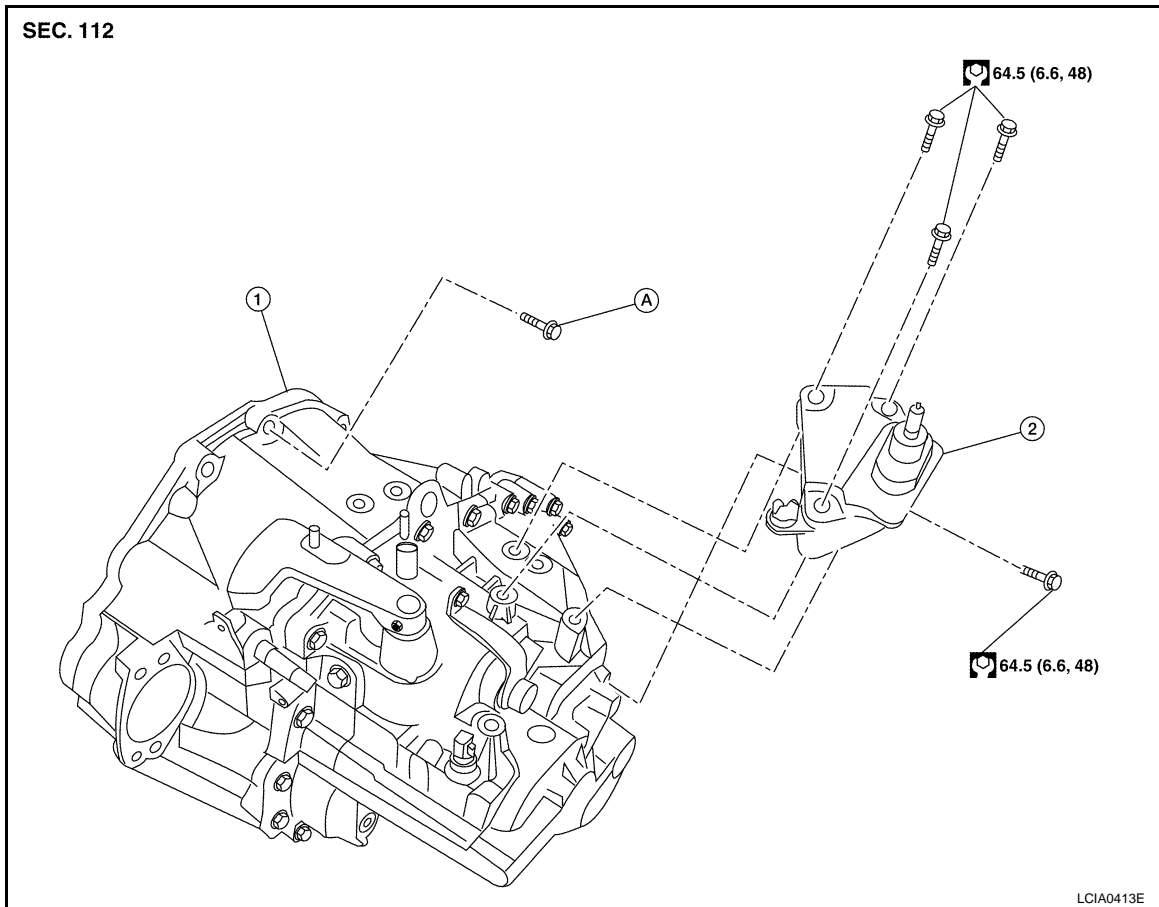

1. Transaxle assembly
2. LH engine mount bracket
- A. Refer to [MT-143, "Removal and Installation"](#).

### Removal and Installation

INFOID:000000001850914

#### CAUTION:

If transaxle assembly is removed from the vehicle, always replace CSC (Concentric Slave Cylinder). Inserted CSC returns to the original position when removing transaxle assembly. Dust on clutch disc sliding parts may damage CSC seal, and may cause clutch fluid leakage.

#### REMOVAL

1. Drain gear oil. Refer to [MT-137, "Changing M/T Oil"](#).
2. Drain clutch fluid and remove clutch tube from CSC. Refer to [CL-12, "Removal and Installation"](#).

#### CAUTION:

**Do not depress clutch pedal during removal procedure.**

3. Remove engine and transaxle assembly. Refer to [EM-177, "Removal and Installation"](#).
4. Remove starter motor. Refer to [SC-21, "Removal and Installation QR25DE"](#).
5. Remove transaxle assembly to engine bolts.
6. Separate transaxle assembly from engine.

#### INSTALLATION

Installation is in the reverse order of removal.

- If transaxle assembly is removed from the vehicle, always replace CSC. Refer to [CL-11, "Removal and Installation"](#).

# TRANSAXLE ASSEMBLY

[RS6F52H]

## < SERVICE INFORMATION >

- When installing the transaxle assembly to the engine, use the specified tightening torque in the numerical sequence shown:

- : Transaxle to engine
- X : Engine to transaxle

### CAUTION:

When installing transaxle assembly, do not allow the transaxle input shaft to make contact with the clutch cover.

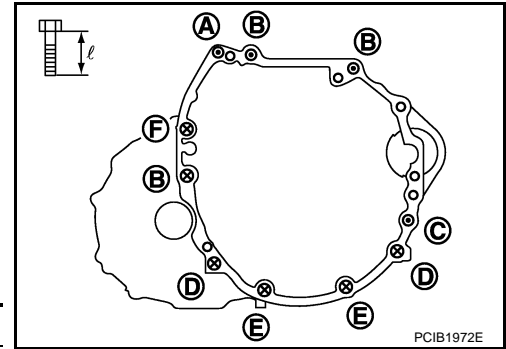

Bolt symbol	A	B	C	D	E	F
Quantity	1	3	1	2	2	1
Bolt length "ℓ" mm (in)	45 (1.77)		80 (3.15)	45 (1.77)	35 (1.38)	45 (1.77)
Tightening torque N·m (kg·m, ft·lb)	35.3 (3.6, 26)		74.5 (7.6, 55)	42.6 (4.3, 31)		48.0 (4.9, 35)

- Bleed the air from the clutch hydraulic system. Refer to [CL-8. "Air Bleeding Procedure"](#).
- After installation, check oil level and check for leaks and loose mechanisms. Refer to [MT-137. "Checking M/T Oil"](#).

## Disassembly and Assembly

INFOID:000000001850915

### COMPONENTS

#### Case and Housing Components



# TRANSAXLE ASSEMBLY

< SERVICE INFORMATION >

[RS6F52H]

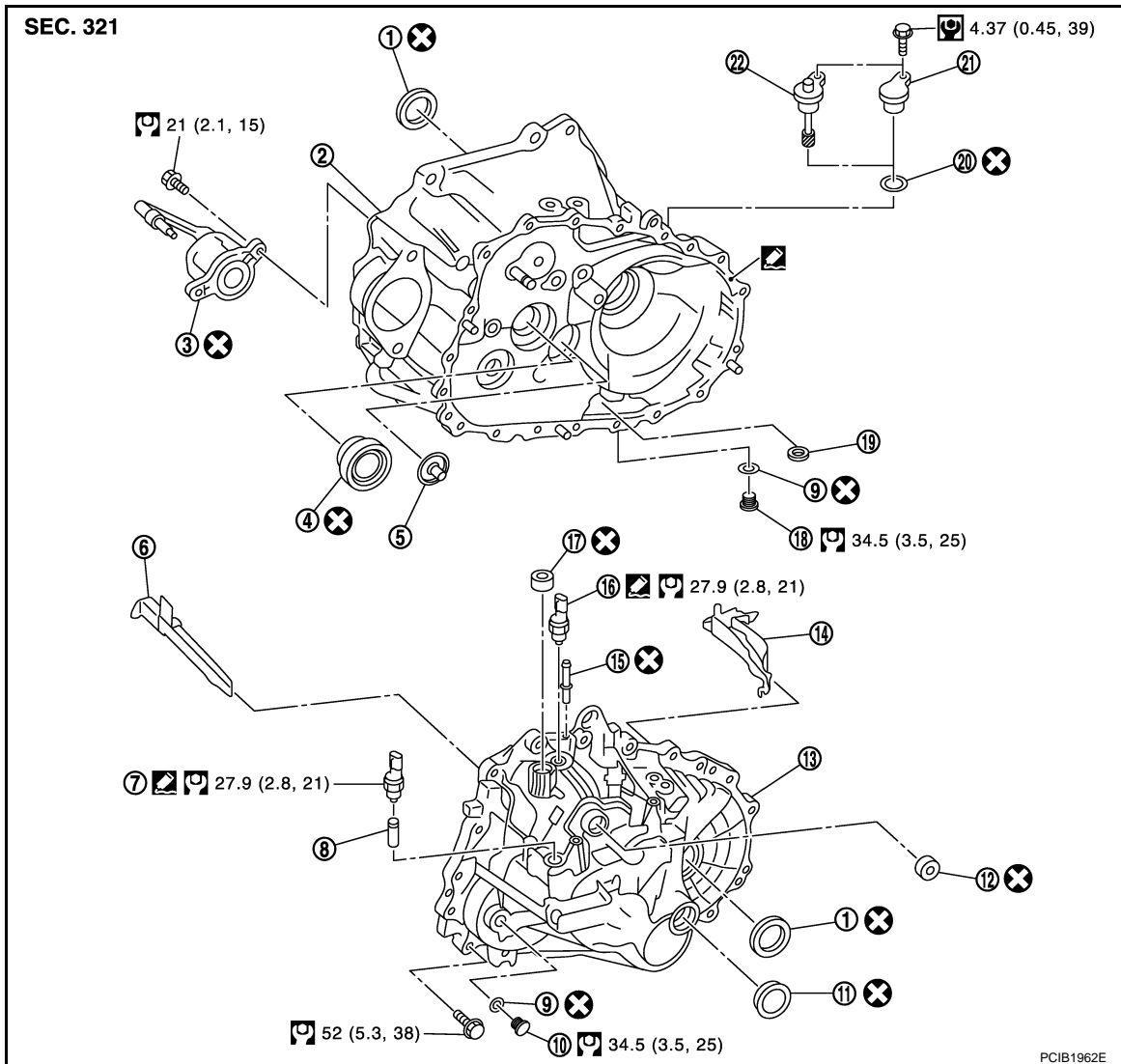

- |  |                            |                                    |
|--|----------------------------|------------------------------------|
| 1. Differential side oil seal                    | 2. Clutch housing          | 3. CSC (Concentric Slave Cylinder) |
| 4. Input shaft oil seal                          | 5. Oil channel             | 6. Oil gutter A                    |
| 7. Back-up lamp switch                           | 8. Plunger                 | 9. Gasket                          |
| 10. Plug   | 11. Bore plug              | 12. Striking rod oil seal          |
| 13. Transaxle case                               | 14. Oil gutter B           | 15. Air breather tube              |
| 16. Park/Neutral position (PNP) switch           | 17. Shifter lever oil seal | 18. Drain plug                     |
| 19. Magnet                                       | 20. O-ring                 | 21. Plug (With ABS models)         |
| 22. Speedometer pinion gear (Without ABS models) |                            |                                    |

: Apply Genuine Silicone RTV or an equivalent. Refer to [GI-42, "Recommended Chemical Product and Sealant"](#).

Gear Components

# TRANSAXLE ASSEMBLY

< SERVICE INFORMATION >

[RS6F52H]

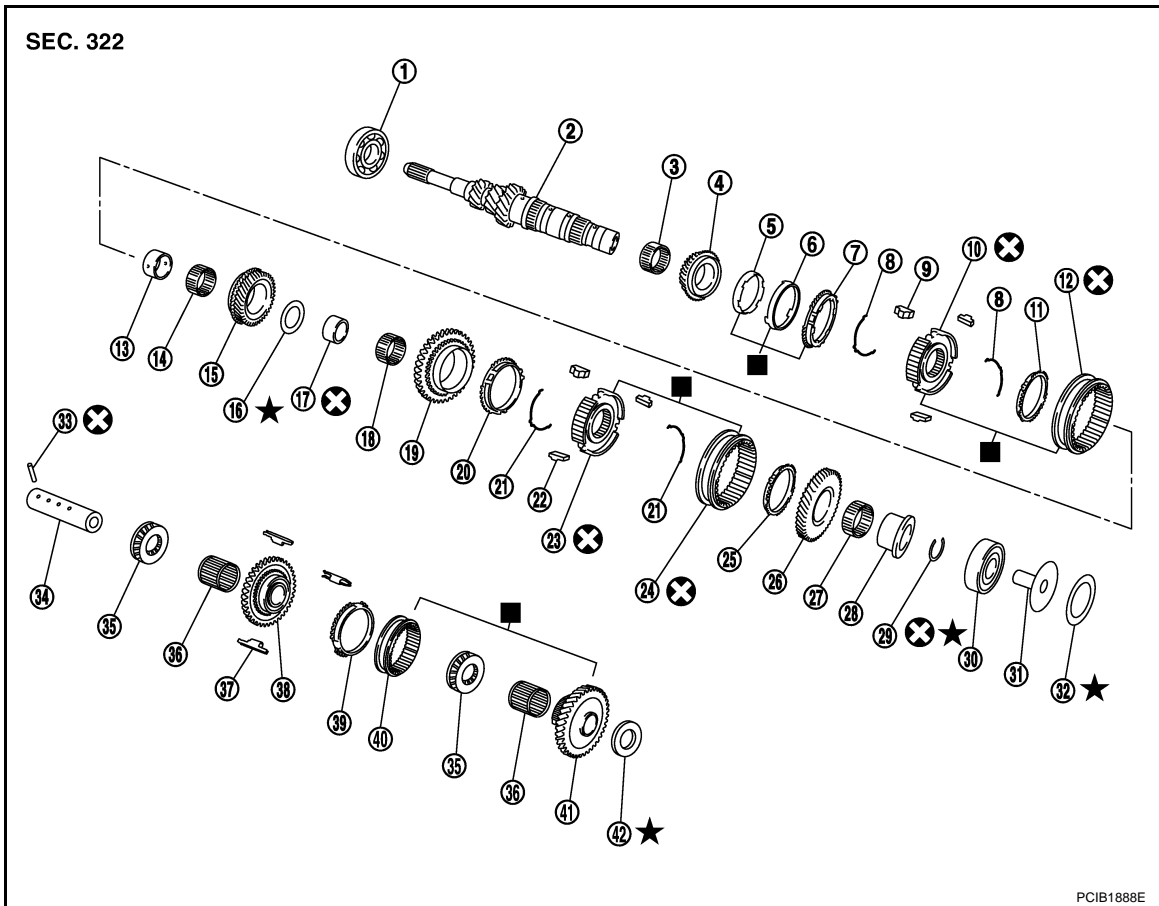

- |                              |   |                                       |
|------------------------------|---|---------------------------------------|
| 1. Input shaft front bearing | 2. Input shaft                              | 3. 3rd needle bearing                 |
| 4. 3rd input gear            | 5. 3rd inner baulk ring                     | 6. 3rd synchronizer cone              |
| 7. 3rd outer baulk ring      | 8. 3rd-4th spread spring                    | 9. 3rd-4th shifting insert            |
| 10. 3rd-4th synchronizer hub | 11. 4th baulk ring                          | 12. 3rd-4th coupling sleeve           |
| 13. 4th input gear bushing   | 14. 4th needle bearing                      | 15. 4th input gear                    |
| 16. Thrust washer            | 17. 5th input gear bushing                  | 18. 5th needle bearing                |
| 19. 5th input gear           | 20. 5th baulk ring                          | 21. 5th-6th spread spring             |
| 22. 5th-6th shifting insert  | 23. 5th-6th synchronizer hub                | 24. 5th-6th coupling sleeve           |
| 25. 6th baulk ring           | 26. 6th input gear                          | 27. 6th needle bearing                |
| 28. 6th input gear bushing   | 29. Snap ring                               | 30. Input shaft rear bearing          |
| 31. Oil channel              | 32. Input shaft rear bearing adjusting shim | 33. Retaining pin                     |
| 34. Reverse idler shaft      | 35. Thrust needle bearing                   | 36. Reverse idler gear needle bearing |
| 37. Reverse insert spring    | 38. Reverse idler gear (front)              | 39. Reverse baulk ring                |
| 40. Reverse coupling sleeve  | 41. Reverse idler gear (rear)               | 42. Reverse idler gear adjusting shim |

■: Replace the parts as a set.

Refer to [GI-8. "Component"](#) for symbols not described.

- Apply gear oil to gears, shafts, synchronizers, and bearings when assembly.

# TRANSAXLE ASSEMBLY

< SERVICE INFORMATION >

[RS6F52H]

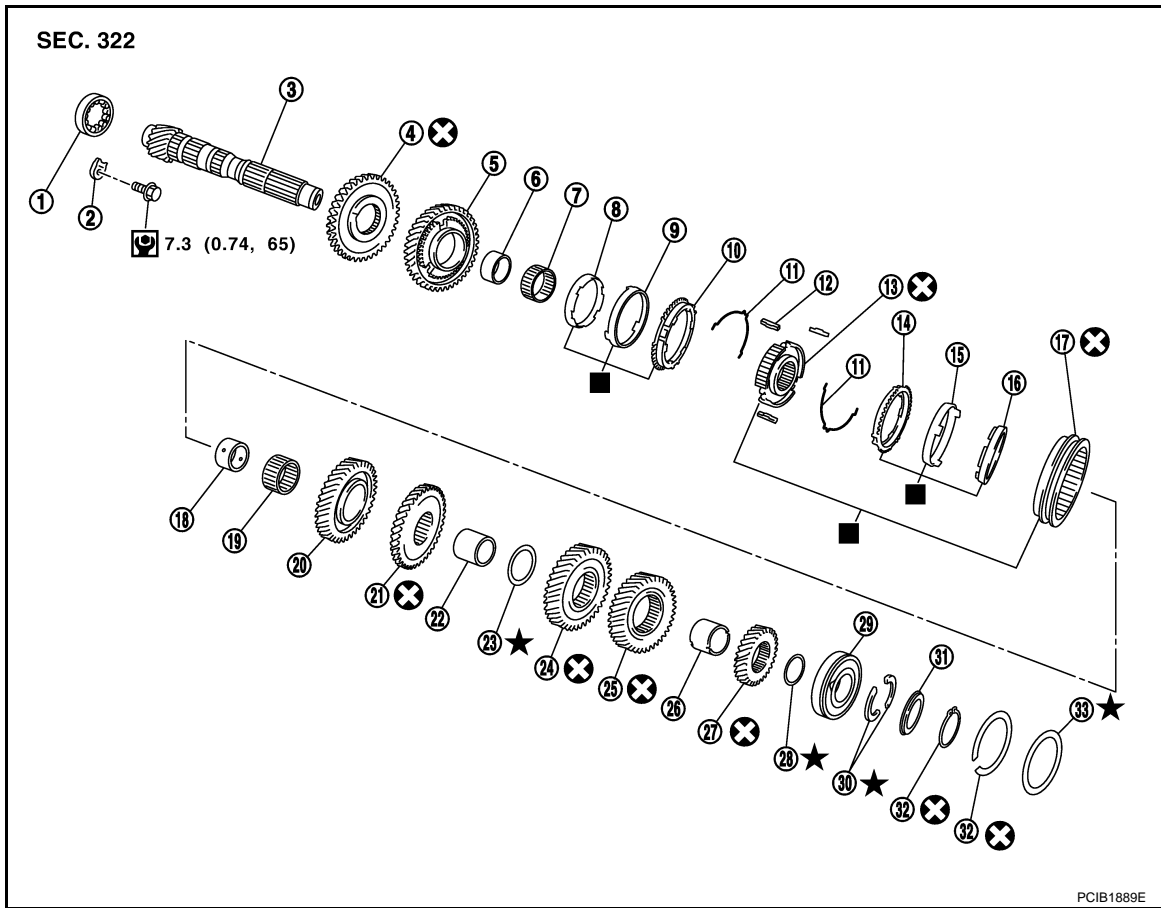

- |                                  |                                  |   |
|----------------------------------|----------------------------------|---|
| 1. Mainshaft front bearing       | 2. Mainshaft bearing retainer    | 3. Mainshaft                              |
| 4. Reverse main gear             | 5. 1st main gear                 | 6. 1st main gear bushing                  |
| 7. 1st needle bearing            | 8. 1st inner baulk ring          | 9. 1st synchronizer cone                  |
| 10. 1st outer baulk ring         | 11. 1st-2nd spread spring        | 12. 1st-2nd shifting insert               |
| 13. 1st-2nd synchronizer hub     | 14. 2nd outer baulk ring         | 15. 2nd synchronizer cone                 |
| 16. 2nd inner baulk ring         | 17. 1st-2nd coupling sleeve      | 18. 2nd main gear bushing                 |
| 19. 2nd needle bearing           | 20. 2nd main gear                | 21. 3rd main gear                         |
| 22. 3rd-4th mainshaft spacer     | 23. 4th main gear adjusting shim | 24. 4th main gear                         |
| 25. 5th main gear                | 26. 5th-6th mainshaft spacer     | 27. 6th main gear                         |
| 28. 6th main gear adjusting shim | 29. Mainshaft rear bearing       | 30. Mainshaft C-ring                      |
| 31. C-ring holder                | 32. Snap ring                    | 33. Mainshaft rear bearing adjusting shim |

■: Replace the parts as a set.

Refer to [GI-8, "Component"](#) for symbols not described.

- Apply gear oil to gears, shafts, synchronizers, and bearings when assembly.

Shift Control Components

A  
B  
MT  
D  
E  
F  
G  
H  
I  
J  
K  
L  
M  
N  
O  
P

# TRANSAXLE ASSEMBLY

< SERVICE INFORMATION >

[RS6F52H]

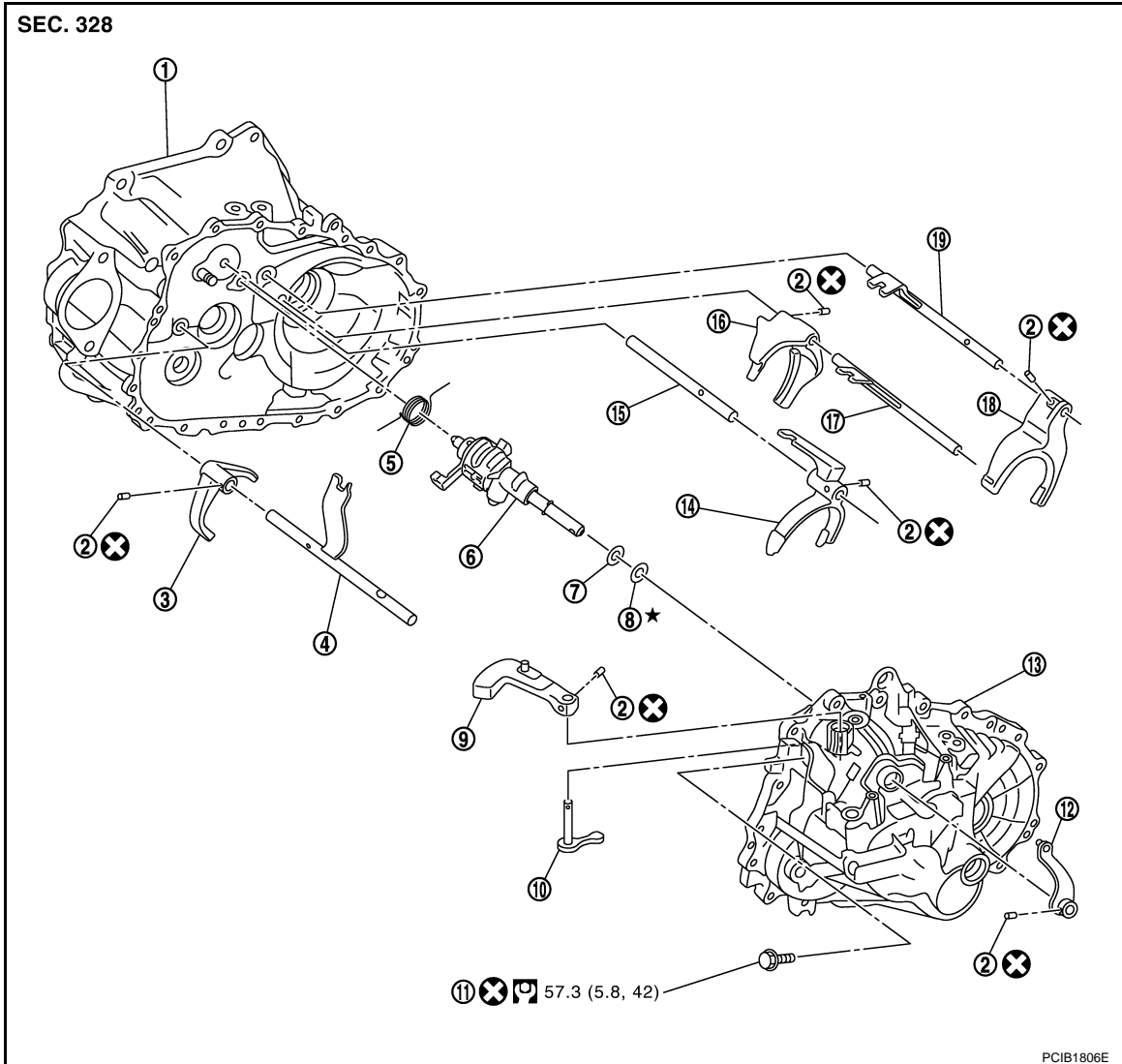

- |                        |                                |                          |
|------------------------|--------------------------------|--------------------------|
| 1. Clutch housing      | 2. Retaining pin               | 3. Reverse shift fork    |
| 4. Reverse fork rod    | 5. Return spring               | 6. Striking rod assembly |
| 7. Striking rod shim   | 8. Striking rod adjusting shim | 9. Shifter lever A       |
| 10. Shifter lever B    | 11. Guide bolt                 | 12. Selector lever       |
| 13. Transaxle case     | 14. 3rd-4th shift fork         | 15. 3rd-4th fork rod     |
| 16. 1st-2nd shift fork | 17. 1st-2nd fork rod           | 18. 5th-6th shift fork   |
| 19. 5th-6th fork rod   |                                |                          |

Refer to [GI-8. "Component"](#) for symbols not described.

Final Drive Components

# TRANSAXLE ASSEMBLY

< SERVICE INFORMATION >

[RS6F52H]

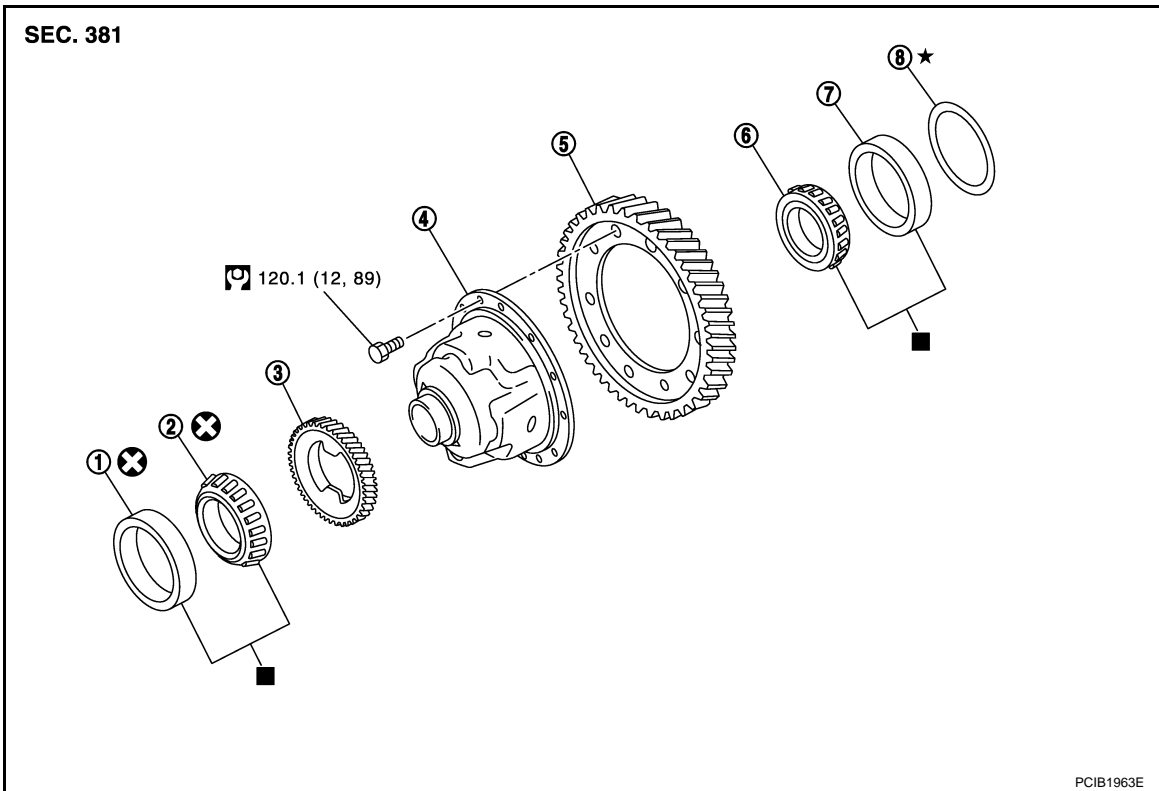

- |   |  |  |
|---|--|--|
| 1. Differential side bearing outer race (clutch housing side) | 2. Differential side bearing (clutch housing side) | 3. Speedometer drive gear                          |
| 4. Differential case assembly                                 | 5. Final gear                                      | 6. Differential side bearing (transaxle case side) |
| 7. Differential side bearing outer race (transaxle case side) | 8. Differential side bearing adjusting shim        |  |

■: Replace the parts as a set.

Refer to [GI-8. "Component"](#) for symbols not described.

## DISASSEMBLY

1. Remove drain plug and gasket from clutch housing.

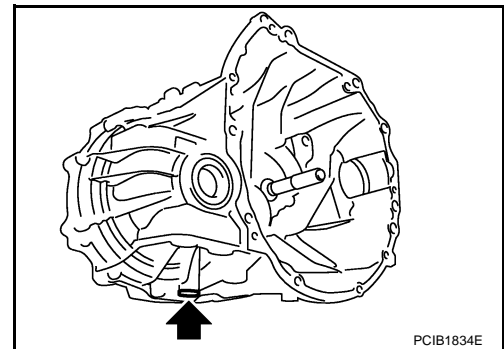

A  
B  
MT  
D  
E  
F  
G  
H  
I  
J  
K  
L  
M  
N  
O  
P

# TRANSAXLE ASSEMBLY

[RS6F52H]

## < SERVICE INFORMATION >

2. Remove plug bolt and then plug (with ABS models) or speedometer pinion gear (without ABS models) and O-ring from clutch housing.

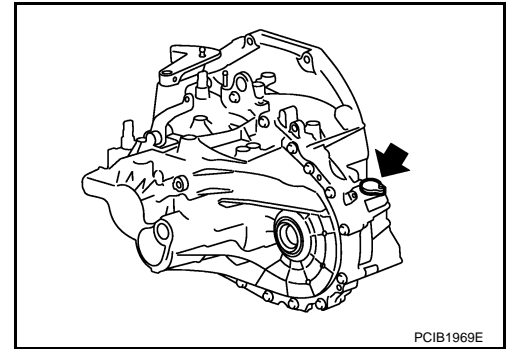

3. Remove plug and gasket from transaxle case.

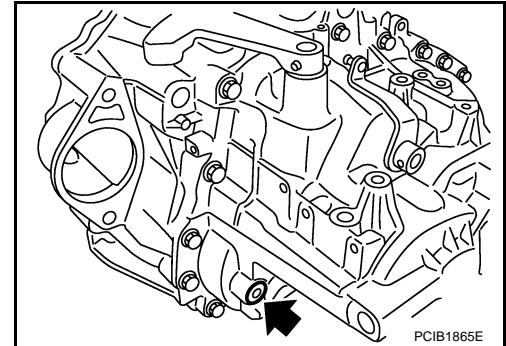

4. Remove park/neutral position (PNP) switch (1) from transaxle case.
5. Remove back-up lamp switch (2) and plunger from transaxle case.

**CAUTION:**

**Do not lose plunger.**

6. Remove air breather tube (3) from transaxle case.

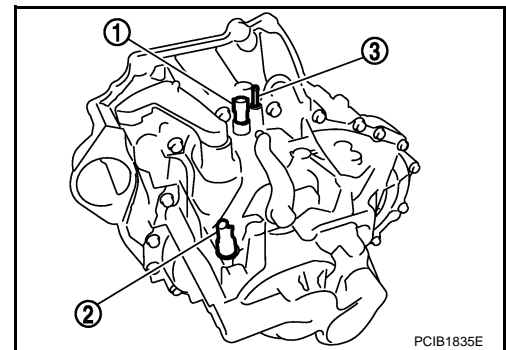

7. Remove guide bolt from transaxle case.

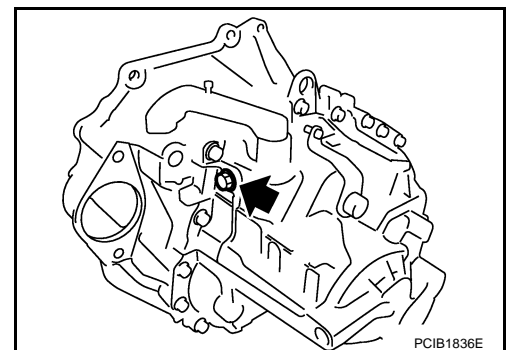

8. Remove retaining pin using suitable tool and then remove selector lever from transaxle case.

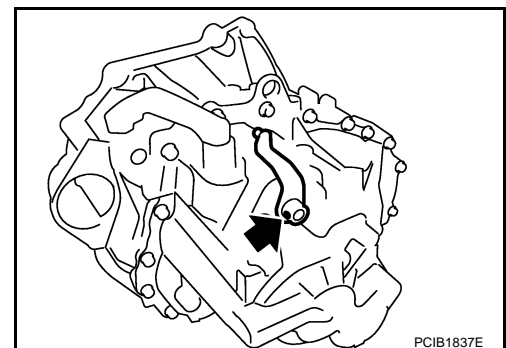

# TRANSAXLE ASSEMBLY

[RS6F52H]

< SERVICE INFORMATION >

9. Remove transaxle case bolts.

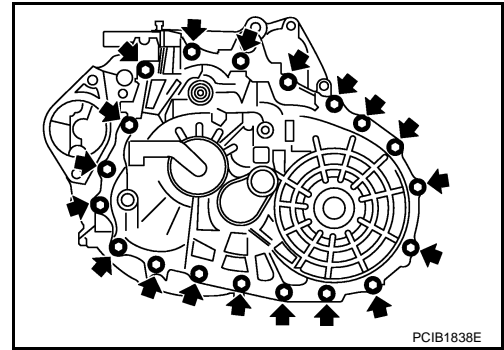

10. Remove bore plug from transaxle case using suitable tool.

**CAUTION:**

- Do not damage transaxle case.
- Access bore plug from cutout (A) of transaxle case when removing.

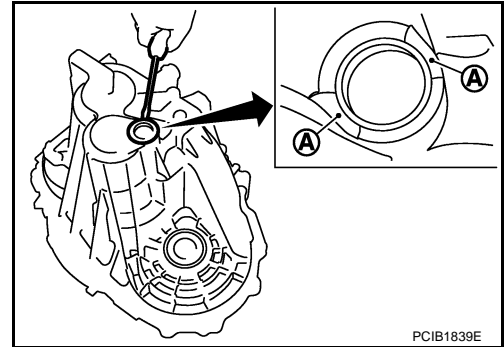

11. Remove transaxle case following the procedures below.

a. Expand snap ring at mainshaft rear bearing accessing from the bore plug hole. Then pull up transaxle case from clutch housing until snap ring comes off.

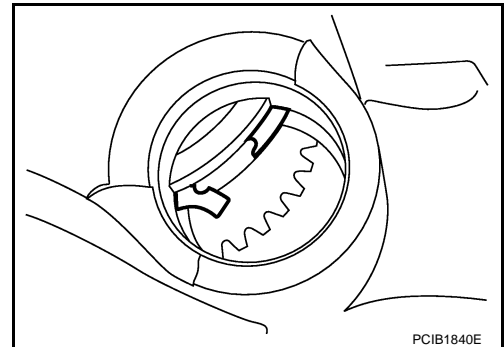

b. With shifter lever A (1) held in the position shown, remove transaxle case from clutch housing.

**CAUTION:**

**Do not drop adjusting shims.**

**NOTE:**

Make sure to hold shifter lever A in the position shown. Otherwise transaxle case cannot be removed from clutch housing.

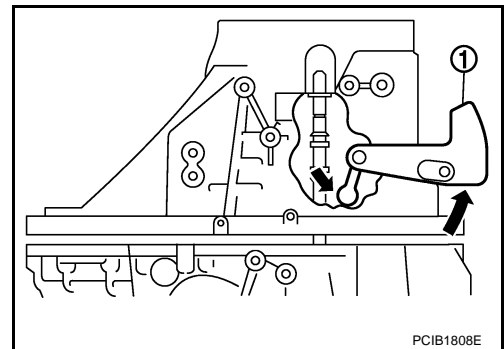

A  
B  
MT  
D  
E  
F  
G  
H  
I  
J  
K  
L  
M  
N  
O  
P

# TRANSAXLE ASSEMBLY

[RS6F52H]

## < SERVICE INFORMATION >

12. Remove oil gutter A (1) and oil gutter B (2) from transaxle case.

A : Tab of oil gutter

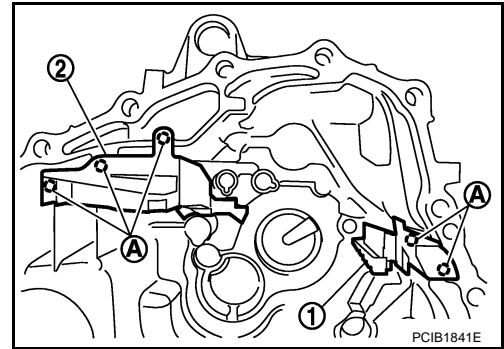

13. Remove snap ring from transaxle case.

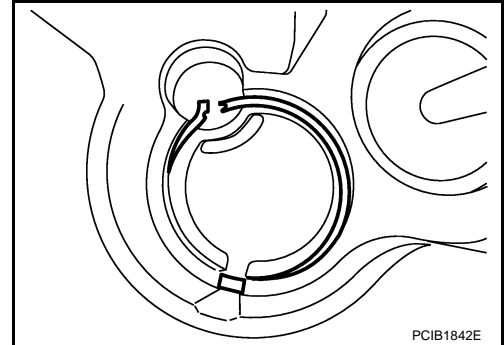

14. Remove retaining pin using suitable tool and then remove shifter lever A and shifter lever B from transaxle case.

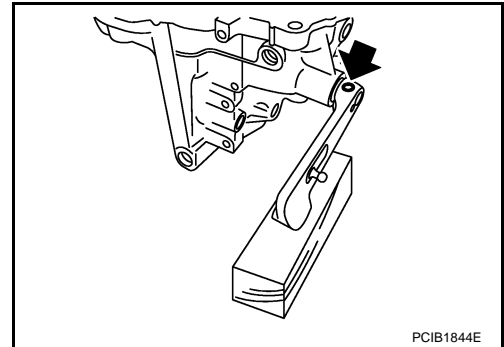

15. Remove differential side bearing outer race (transaxle case side) from transaxle case using Tool. Then remove differential side bearing adjusting shim from transaxle case.

**CAUTION:**

**Do not damage transaxle case or differential side bearing outer race.**

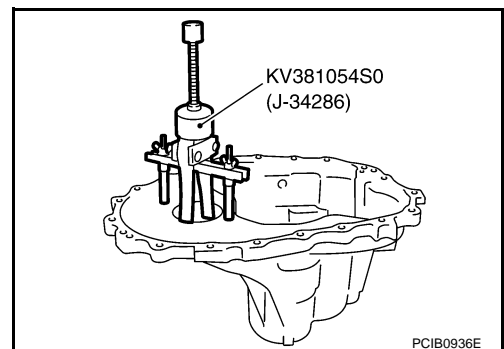

16. Remove differential side oil seal from transaxle case using suitable tool.

**CAUTION:**

**Do not damage transaxle case.**

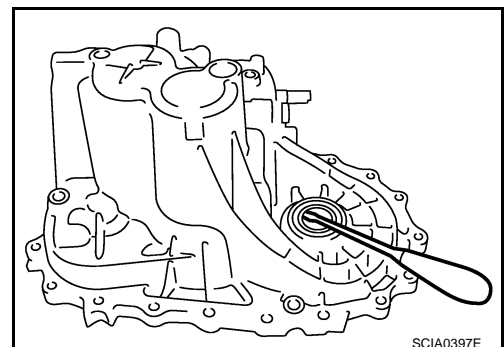



# TRANSAXLE ASSEMBLY

[RS6F52H]

## < SERVICE INFORMATION >

17. Remove shifter lever oil seal (1) and striking rod oil seal (2) from transaxle case.

**CAUTION:**

**Do not damage transaxle case.**

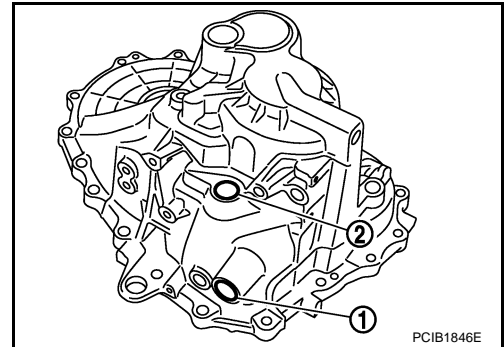

18. Remove striking rod shim (1), striking rod adjusting shim (2), mainshaft rear bearing adjusting shim (3), input shaft rear bearing adjusting shim (4), and reverse idler gear adjusting shim (5).

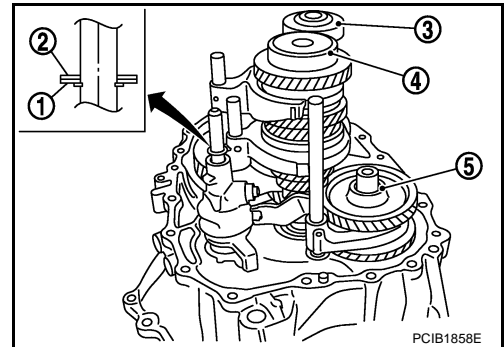

19. Remove retaining pin of reverse shift fork (1) using suitable tool.

2 : Reverse fork rod

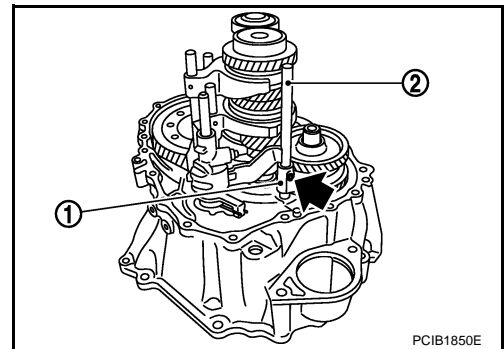

20. Rotate striking lever of striking rod assembly as shown. Then rotate reverse fork rod to a position where bracket of reverse fork rod does not interfere with striking lever of striking rod assembly.

21. Pull out reverse shift fork and reverse fork rod.

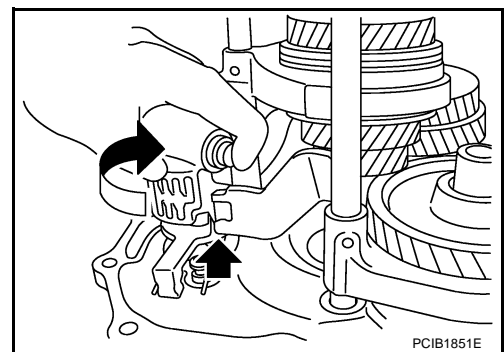

22. Remove retaining pin of 5th-6th shift fork (1) using suitable tool.

2 : 5th-6th fork rod

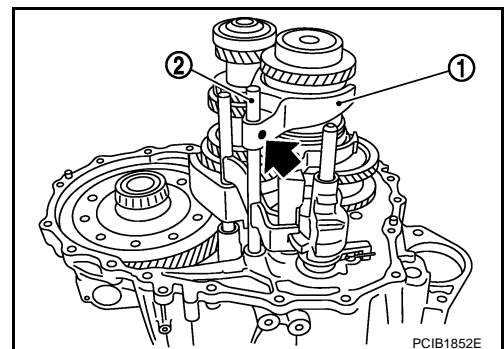

A  
B  
MT  
D  
E  
F  
G  
H  
I  
J  
K  
L  
M  
N  
O  
P

# TRANSAXLE ASSEMBLY

[RS6F52H]

< SERVICE INFORMATION >

23. Remove retaining pin of 3rd-4th shift fork (1) using suitable tool.

24. Pull out 3rd-4th fork rod (2).

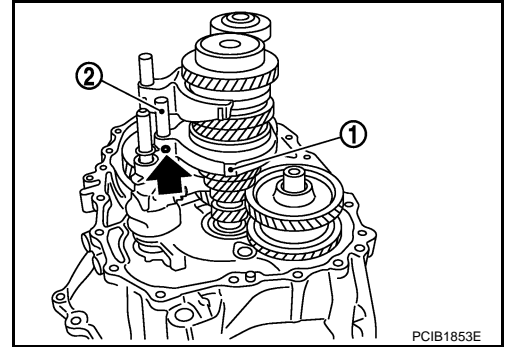

25. Pull out 5th-6th shift fork (1) and 5th-6th fork rod (2).

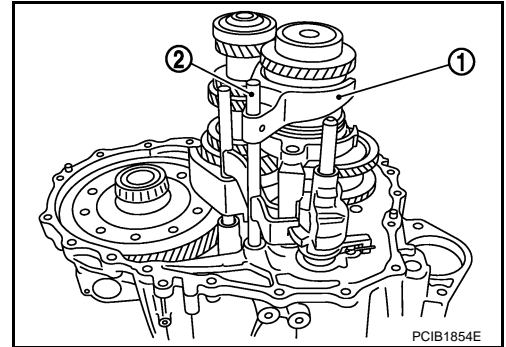

26. Pull out 3rd-4th shift fork (1).

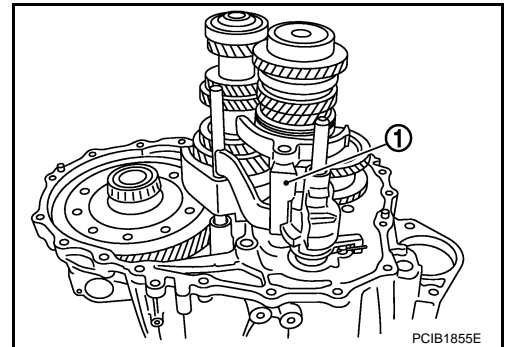

27. Remove retaining pin of 1st-2nd shift fork (1) using suitable tool.

28. Pull out 1st-2nd shift fork and 1st-2nd fork rod (2).

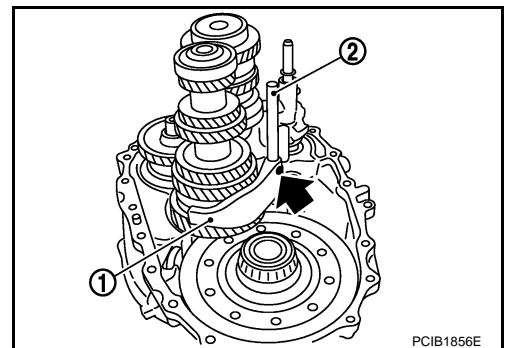

29. Remove striking rod assembly (1).

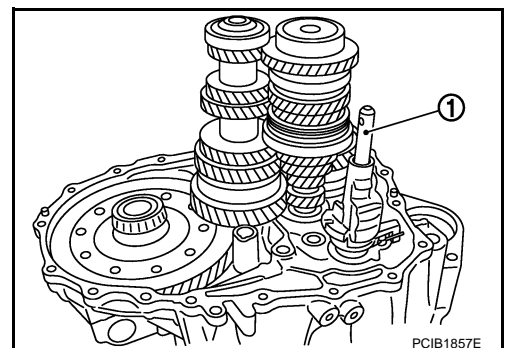

# TRANSAXLE ASSEMBLY

[RS6F52H]

## < SERVICE INFORMATION >

30. Remove gear components from clutch housing in the following procedure.

- a. Remove a set of input shaft assembly, mainshaft assembly, and reverse idler gear assembly by tapping the tip of input shaft from the back of the clutch housing with a plastic hammer.

**CAUTION:**

**Always withdraw mainshaft straight out. Failure to do so can damage resin oil channel on clutch housing side.**

- b. Remove final drive assembly.

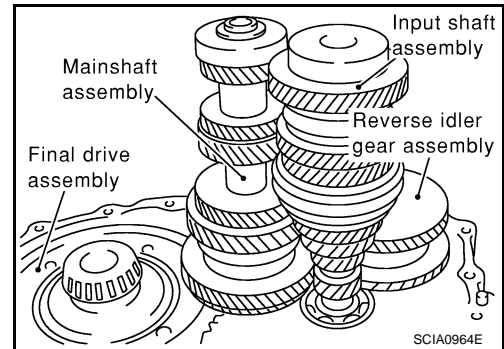

31. Remove magnet from clutch housing.

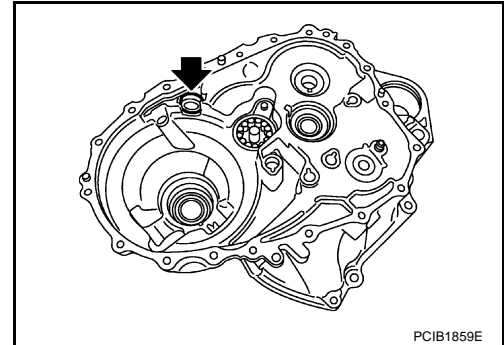

32. Remove mainshaft bearing retainer and then mainshaft front bearing from clutch housing using the puller.

**CAUTION:**

**Do not damage clutch housing, mainshaft front bearing, or oil channel.**

33. Remove oil channel from clutch housing.

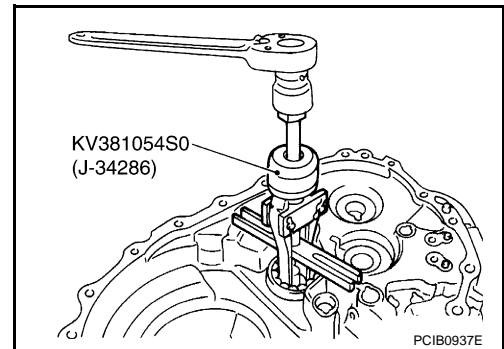

34. Remove differential side bearing outer race (clutch housing side) from clutch housing using the puller.

**CAUTION:**

**Do not damage clutch housing or differential side bearing outer race.**

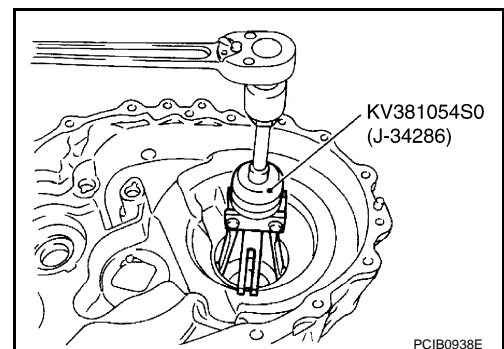

35. Remove input shaft oil seal from clutch housing.

**CAUTION:**

**Do not damage clutch housing.**

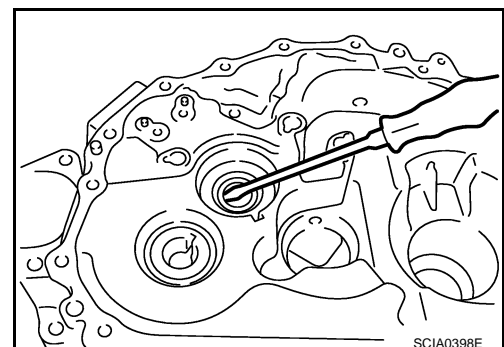

A  
B  
MT  
D  
E  
F  
G  
H  
I  
J  
K  
L  
M  
N  
O  
P

# TRANSAXLE ASSEMBLY

< SERVICE INFORMATION >

[RS6F52H]

36. Remove differential side oil seal from clutch housing.

**CAUTION:**

Do not damage clutch housing.

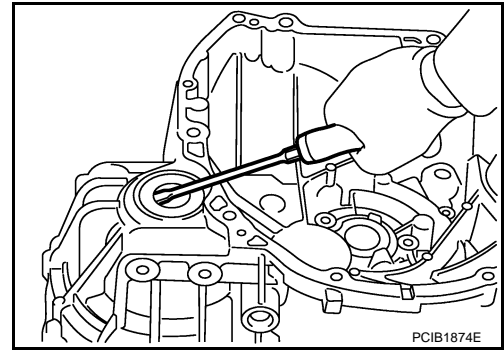

## ASSEMBLY

1. Install differential side oil seal (1) to clutch housing using Tool (A).

Dimension "H" : -0.5 - 0.5 mm (-0.020 - 0.020 in)

Tool number : ST33400001 (J-26082)

**CAUTION:**

- Do not reuse differential side oil seal.
- When installing, do not incline differential side oil seal.
- Do not damage clutch housing.

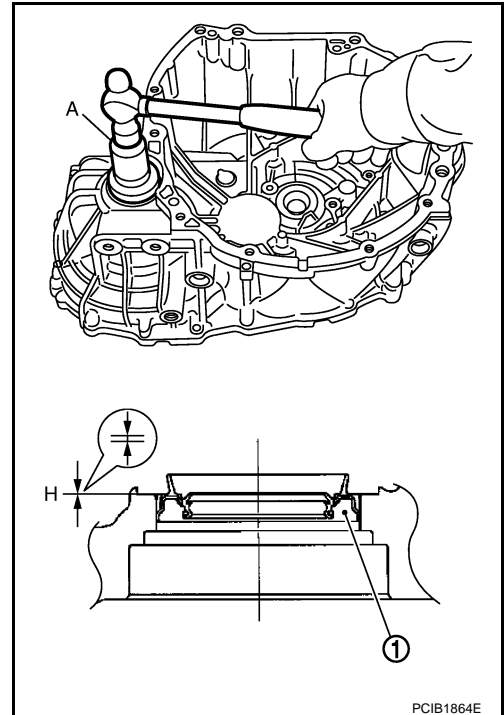

2. Install input shaft oil seal (1) to clutch housing using Tool (A).

Dimension "H" : 1.1 - 2.1 mm (0.043 - 0.083 in)

Tool number : ST35321000 ( — )

**CAUTION:**

- Do not reuse input shaft oil seal.
- When installing, do not incline input shaft oil seal.
- Do not damage clutch housing.

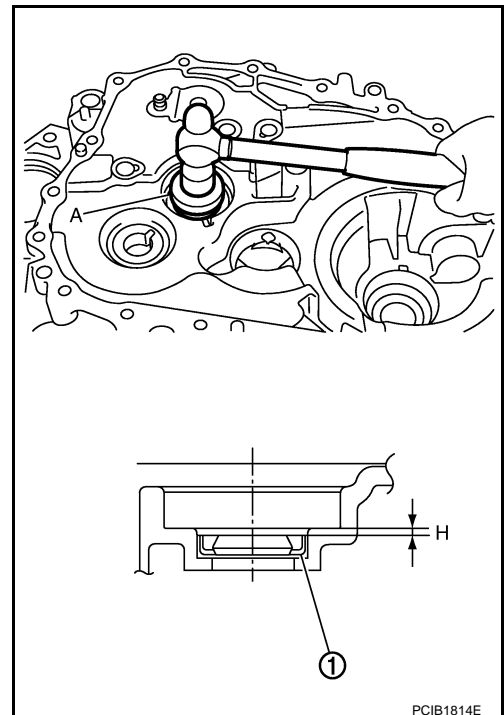

# TRANSAXLE ASSEMBLY

[RS6F52H]

< SERVICE INFORMATION >

3. Install differential side bearing outer race (clutch housing side) to clutch housing using Tools.

**CAUTION:**

Replace differential side bearing and differential side bearing outer race as a set.

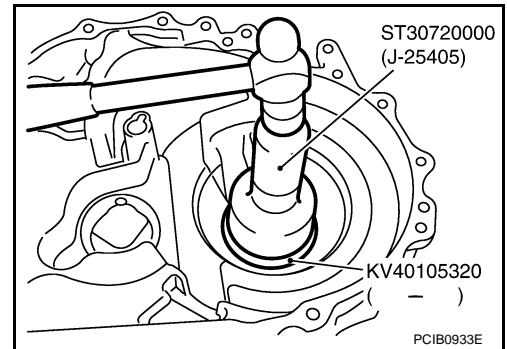

4. Install oil channel (1) on mainshaft side.

**CAUTION:**

When installing oil channel, fit the rib (A) of oil channel into the processed area of the spot facing (B).

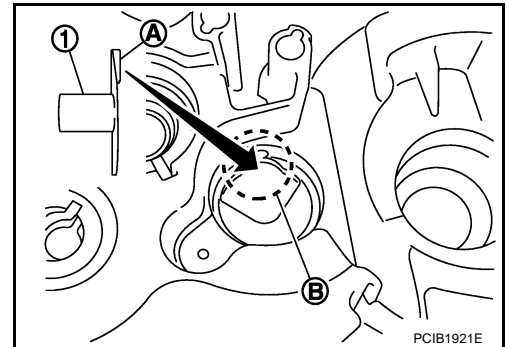

5. Install mainshaft front bearing to clutch housing using Tool.

**CAUTION:**

Be careful with the orientation of mainshaft front bearing.

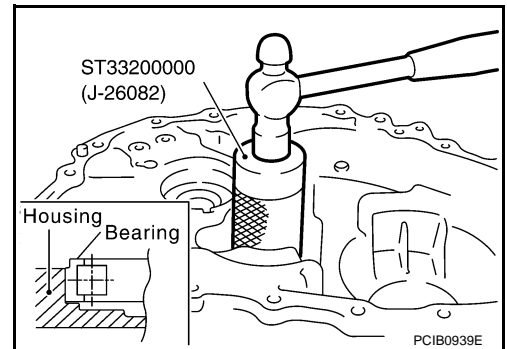

6. Install mainshaft bearing retainer (1) to clutch housing and tighten bolt to the specified torque.

- 2 : Mainshaft front bearing
- 3 : Oil channel

**CAUTION:**

Install with punched surface facing up.

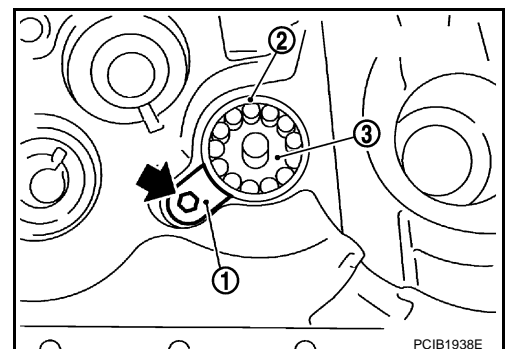

7. Install magnet to clutch housing.

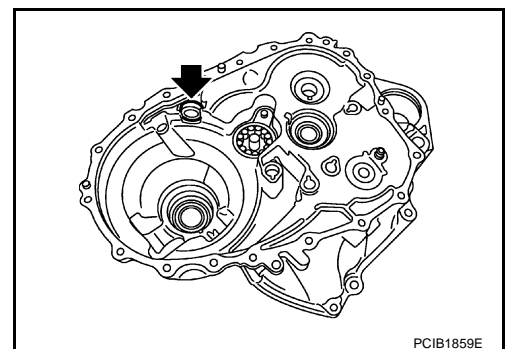

A  
B  
MT  
D  
E  
F  
G  
H  
I  
J  
K  
L  
M  
N  
O  
P

# TRANSAXLE ASSEMBLY

< SERVICE INFORMATION >

[RS6F52H]

8. Install final drive assembly into clutch housing.

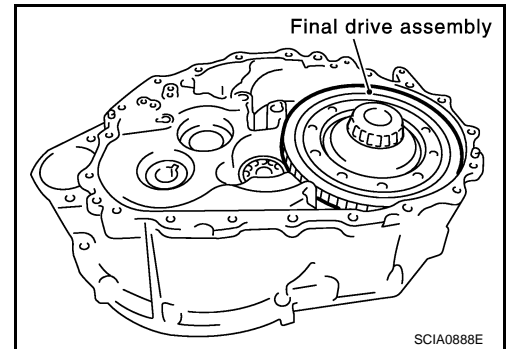

9. Install input shaft assembly, mainshaft assembly, and reverse idler gear assembly into clutch housing.

**CAUTION:**

- Wrap a tape, etc. to the spline of input shaft so as not to damage the input shaft oil seal.
- Be careful with the orientation of reverse idler shaft.

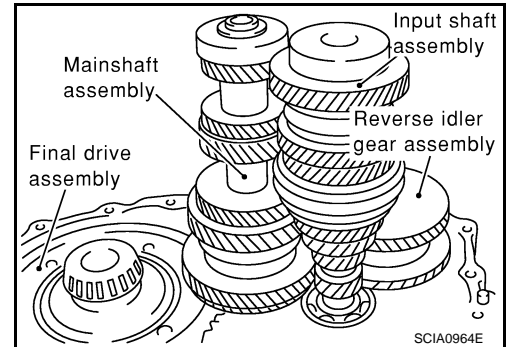

10. Install striking rod assembly (1) into clutch housing.

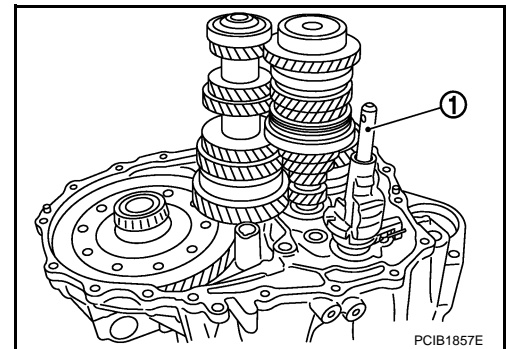

**CAUTION:**

- Check that return spring is securely seated in the groove on return pin.

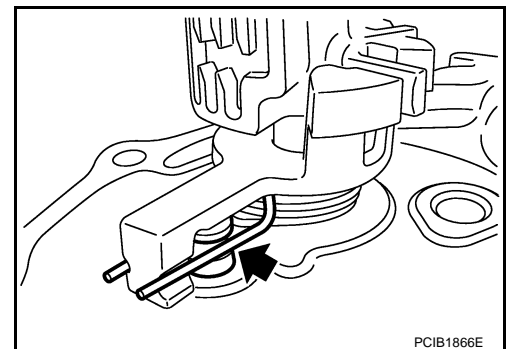

# TRANSAXLE ASSEMBLY

[RS6F52H]

## < SERVICE INFORMATION >

11. Install 1st-2nd shift fork (1) and 1st-2nd fork rod (2) and then install retaining pin to 1st-2nd shift fork.

**CAUTION:**

- Do not reuse retaining pin.
- Be careful with the orientation of 1st-2nd shift fork and 1st-2nd fork rod.
- Assemble retaining pin from the direction shown by the arrow until it becomes flush with the end surface of 1st-2nd shift fork.

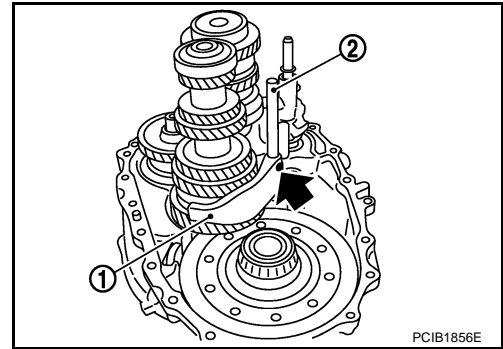

12. Install 3rd-4th shift fork (1) to 3rd-4th coupling sleeve.

**CAUTION:**

- Be careful with the orientation of 3rd-4th shift fork.

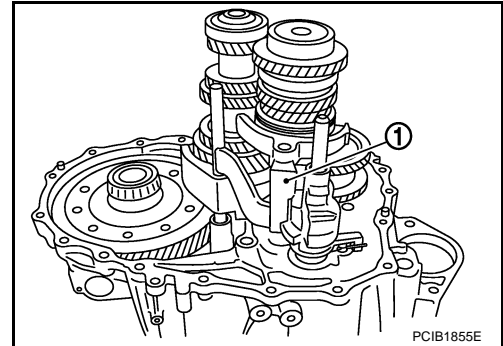

13. Install 5th-6th shift fork (1) and 5th-6th fork rod (2) and then install retaining pin to 5th-6th shift fork.

**CAUTION:**

- Do not reuse retaining pin.
- Be careful with the orientation of 5th-6th shift fork and 5th-6th fork rod.
- Assemble retaining pin from the direction shown by the arrow until it becomes flush with the end surface of 5th-6th shift fork.

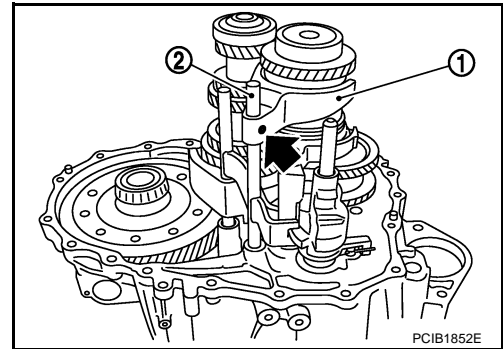

14. Install 3rd-4th fork rod (2) and then install retaining pin to 3rd-4th shift fork (1).

**CAUTION:**

- Do not reuse retaining pin.
- Be careful with the orientation of 3rd-4th fork rod.
- Assemble retaining pin from the direction shown by the arrow until it becomes flush with the end surface of 3rd-4th shift fork.

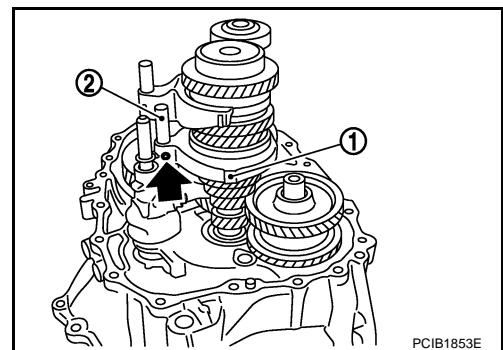

15. Install reverse shift fork (1) and reverse fork rod (2).

**CAUTION:**

- Be careful with the orientation of reverse shift fork and reverse fork rod.

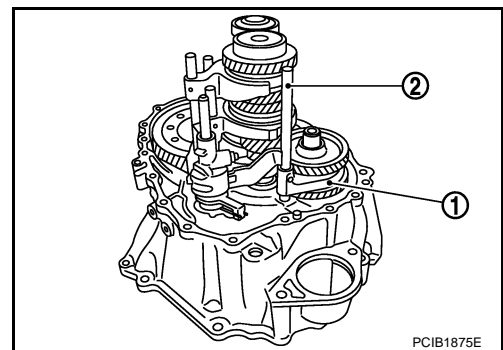

A  
B  
MT  
D  
E  
F  
G  
H  
I  
J  
K  
L  
M  
N  
O  
P

# TRANSAXLE ASSEMBLY

[RS6F52H]

## < SERVICE INFORMATION >

16. Rotate striking lever of striking rod assembly as shown. Then rotate reverse fork rod to a position where bracket of reverse fork rod does not interfere with striking lever of striking rod assembly.

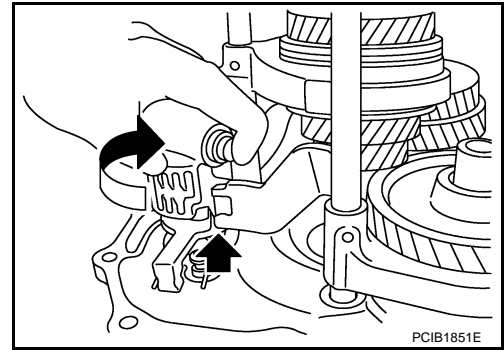

17. Install retaining pin to reverse shift fork (1).

2 : Reverse fork rod

**CAUTION:**

- Do not reuse retaining pin.
- Assemble retaining pin from the direction shown by the arrow until it becomes flush with the end surface of reverse shift fork.

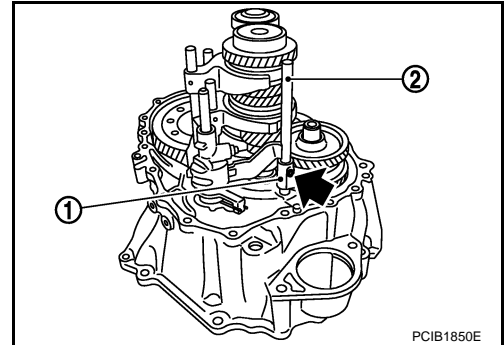

18. Install selected differential side bearing adjusting shim(s) and differential side bearing outer race (transaxle case side).
19. Install selected reverse idler gear adjusting shim onto reverse idler gear assembly.
20. Install selected input shaft rear bearing adjusting shim onto input shaft.
21. Install selected striking rod adjusting shim and striking rod shim onto striking rod assembly.
22. Install shifter lever oil seal (1) and striking rod oil seal (2) to transaxle case using suitable tool.

**Dimension "H" : 0 - 1.0 mm (0 - 0.039 in)**

**CAUTION:**

- Do not reuse shifter lever oil seal or striking rod oil seal.
- When installing, do not incline shifter lever oil seal and striking rod oil seal.
- Do not damage transaxle case.

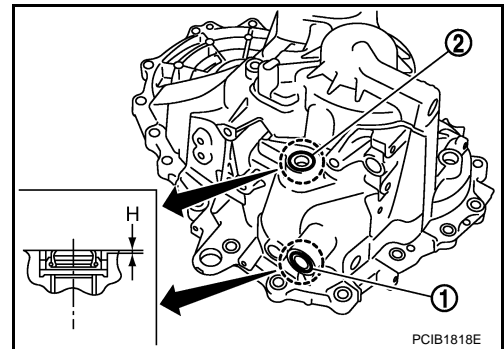



# TRANSAXLE ASSEMBLY

[RS6F52H]

## < SERVICE INFORMATION >

23. Install differential side oil seal (1) to transaxle case using Tool (A).

Dimension "H" : -0.5 - 0.5 mm (-0.020 - 0.020 in)

Tool number : ST30720000 (J-25405)

**CAUTION:**

- Do not reuse differential side oil seal.
- When installing, do not incline differential side oil seal.
- Do not damage transaxle case.

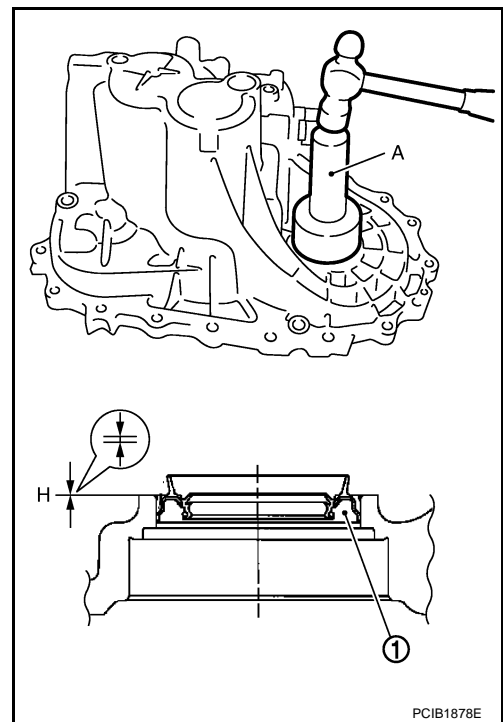

24. Install shifter lever B (1) and shifter lever A (2) to transaxle case.

**CAUTION:**

Be careful with the orientation of shifter lever B and shifter lever A.

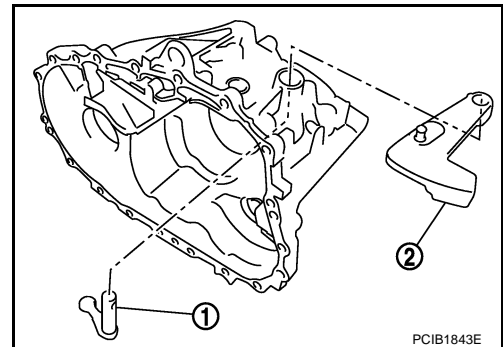

25. Install retaining pin to shifter lever A.

**CAUTION:**

- Do not reuse retaining pin.
- Assemble retaining pin from the direction shown by the arrow until it becomes flush with the end surface of shifter lever A.

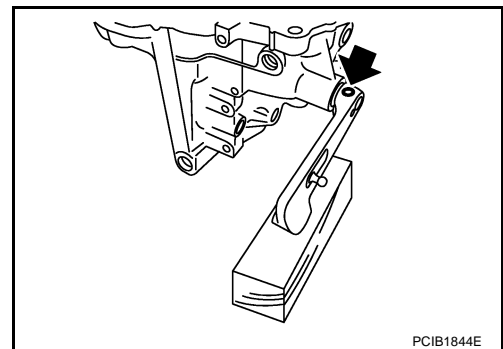

26. Install transaxle case following the procedures below.

- a. Install selected mainshaft rear bearing adjusting shim into transaxle case.

# TRANSAXLE ASSEMBLY

[RS6F52H]

## < SERVICE INFORMATION >

- b. Install oil gutter A (1) and oil gutter B (2) to transaxle case.

**CAUTION:**

Insert the tab (A) of oil gutter A and oil gutter B into transaxle case.

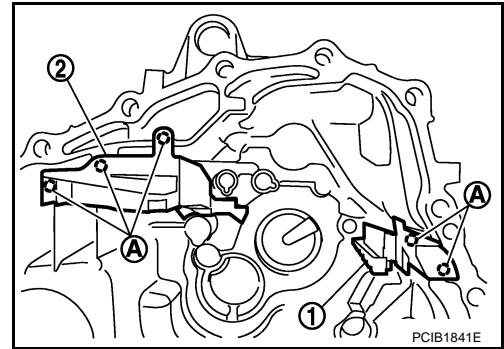

- c. Temporarily install snap ring of mainshaft rear bearing into transaxle case.

**CAUTION:**

Do not reuse snap ring.

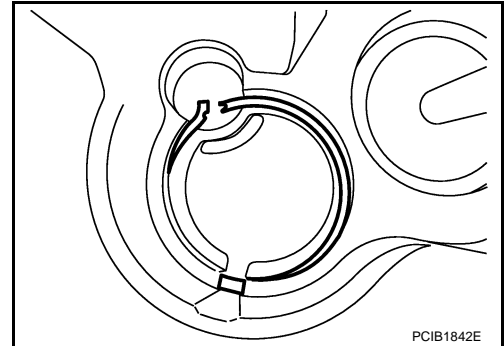

- d. Apply recommended sealant to mating surface of clutch housing as shown.

• Use Genuine Silicone RTV or an equivalent. Refer to [GI-42, "Recommended Chemical Product and Sealant"](#).

**CAUTION:**

- Remove old sealant adhering to the mounting surfaces. Also remove any moisture, oil, or foreign material adhering to both mounting surfaces.
- Apply sealant so as not to break the bead.
- The width of sealant bead is 1 - 2 mm (0.04 - 0.08 in).
- The height of sealant bead is 0.4 - 1 mm (0.016 - 0.04 in).
- The overlap length of both ends of sealant bead is 3 - 5 mm (0.12 - 0.20 in).

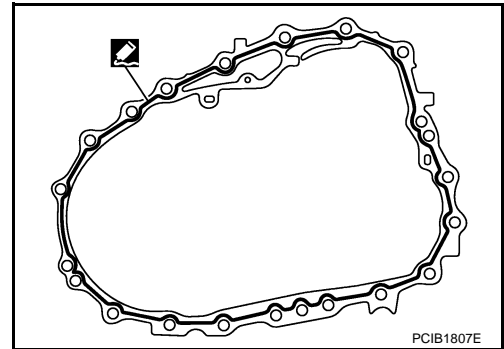

- e. With shifter lever A (1) held in the position shown, temporarily assemble transaxle case to clutch housing.

**CAUTION:**

Do not damage striking rod oil seal.

**NOTE:**

Make sure to hold shifter lever A in the position shown. Otherwise transaxle case cannot be installed to clutch housing.

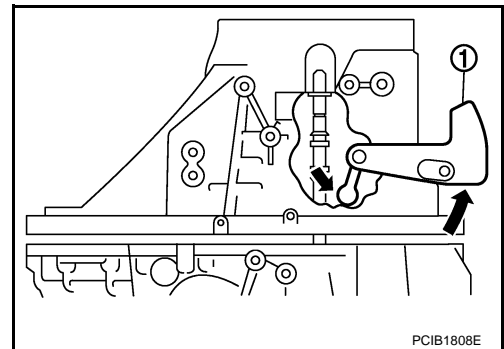

# TRANSAXLE ASSEMBLY

[RS6F52H]

## < SERVICE INFORMATION >

- f. While rotating shifter lever A (1) in the direction of the arrow shown, assemble transaxle case to clutch housing.

2 : shifter lever B

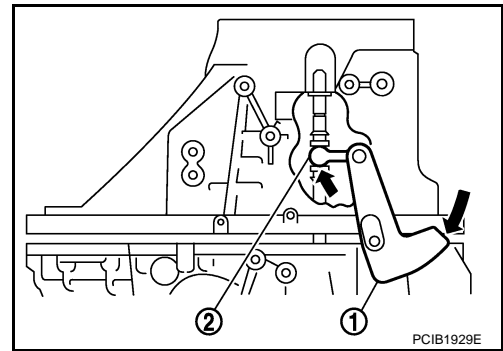

- g. Accessing from the bore plug hole, expand snap ring at mainshaft rear bearing so that the ring catches the periphery of mainshaft rear bearing.
- h. Temporarily tighten transaxle case bolts.

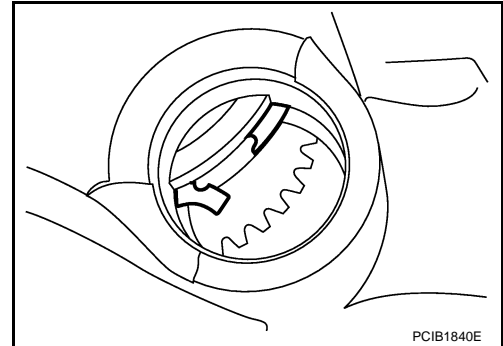

- i. Shift the shifter lever A (1) to 2nd gear position.

**NOTE:**

- The 2nd gear position is attained when shifter lever A is in the position shown.

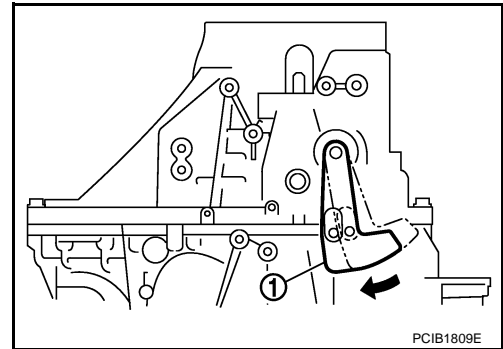

- When transaxle is shifted to the 2nd gear position, mainshaft assembly is lifted.

- j. Seat snap ring in the groove on mainshaft rear bearing. If snap ring is not seated in the groove on mainshaft rear bearing, remove transaxle case and repeat the procedure from step d.

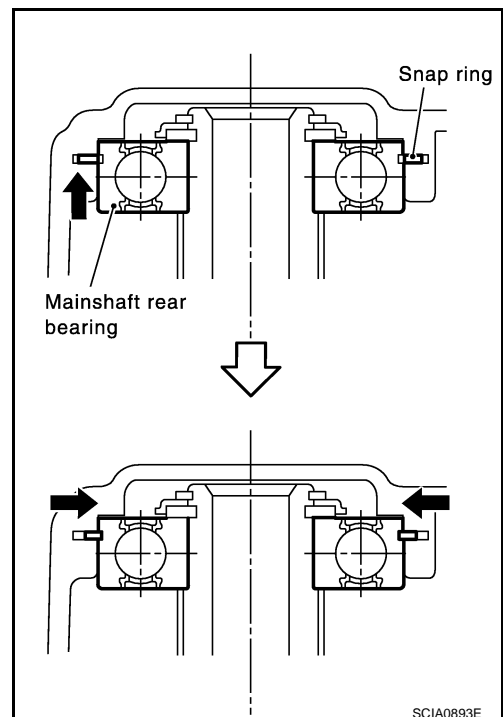

A  
B  
MT  
D  
E  
F  
G  
H  
I  
J  
K  
L  
M  
N  
O  
P

# TRANSAXLE ASSEMBLY

[RS6F52H]

## < SERVICE INFORMATION >

k. Tighten transaxle case bolts to the specified torque.

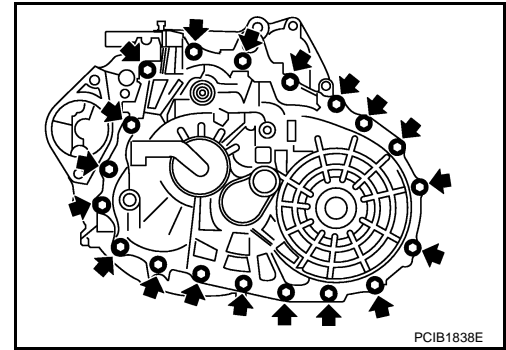

l. Shift the shifter lever A (1) to neutral position.

**NOTE:**

The neutral position is attained when shifter lever A is in the position shown.

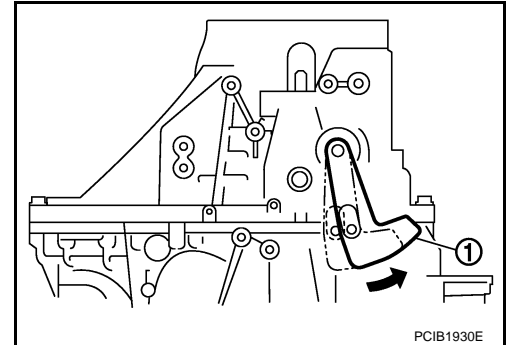

27. Install bore plug to transaxle case using Tool.

**CAUTION:**

**Do not reuse bore plug.**

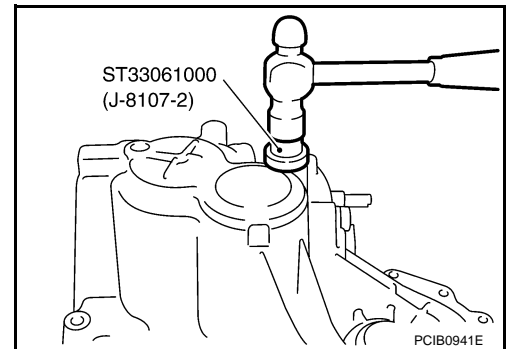

28. Install selector lever to transaxle case and then install retaining pin to selector lever.

**CAUTION:**

- Do not reuse retaining pin.
- Assemble retaining pin from the direction shown by the arrow until it becomes flush with the end surface of selector lever.

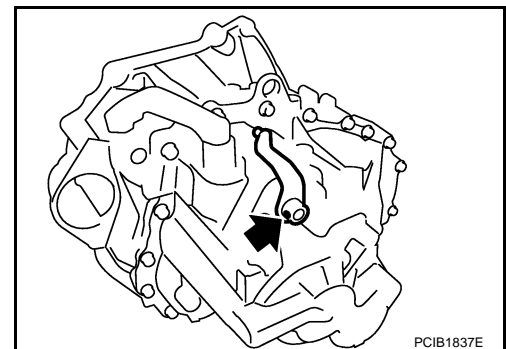

29. Install guide bolt following the procedures below.

a. Shift the shifter lever A and selector lever to neutral position.

# TRANSAXLE ASSEMBLY

[RS6F52H]

## < SERVICE INFORMATION >

- b. Visually confirm from the guide bolt mounting hole (C) that the lever is securely set to neutral position (A). If it is not in the neutral position, repeat the procedure from step a.

1 : Guide bolt

**CAUTION:**

The guide groove (D) of striking rod assembly will be damaged when assembling guide bolt with the lever is in except neutral position (B).

- c. Check continuity between terminals of park/neutral position (PNP) switch to confirm it in the neutral position. If it is not in the neutral position, remove park/neutral position (PNP) switch and repeat the procedure from step a. Refer to [MT-139, "Checking"](#).

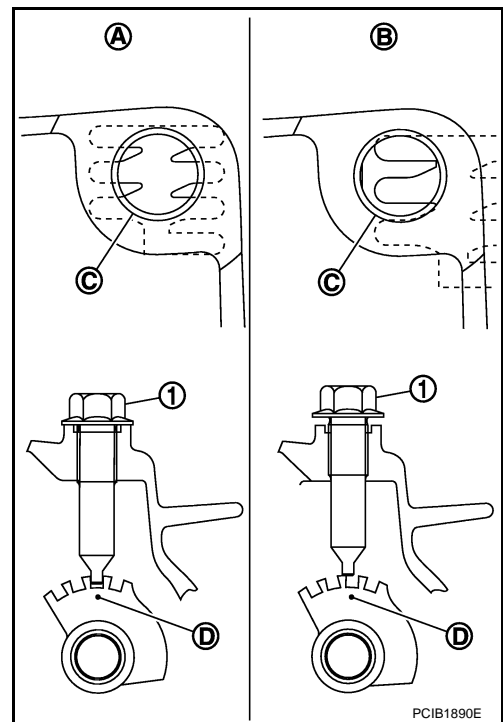

- d. Install guide bolt to transaxle case and then tighten guide bolt to the specified torque.

**CAUTION:**

Do not reuse guide bolt.

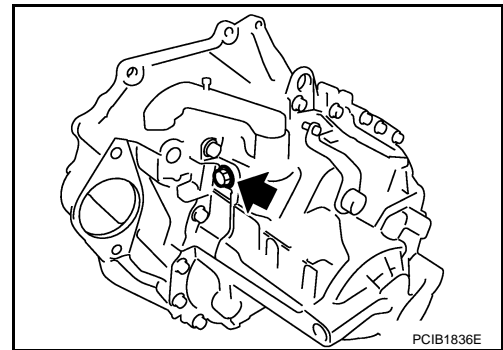

30. Apply recommended sealant to threads of park/neutral position (PNP) switch (1). Then install it to transaxle case and tighten to the specified torque.

• Use Genuine Silicone RTV or an equivalent. Refer to [GI-42, "Recommended Chemical Product and Sealant"](#).

**CAUTION:**

Remove old sealant and oil adhering to threads.

31. Install plunger to transaxle case.

32. Apply recommended sealant to threads of back-up lamp switch (2). Then install it to transaxle case and tighten to the specified torque.

• Use Genuine Silicone RTV or an equivalent. Refer to [GI-42, "Recommended Chemical Product and Sealant"](#).

**CAUTION:**

Remove old sealant and oil adhering to threads.

33. Install air breather tube (3) to transaxle case.

**CAUTION:**

• Do not reuse air breather tube.

• Assemble air breather tube until its collar element contacts with transaxle case.

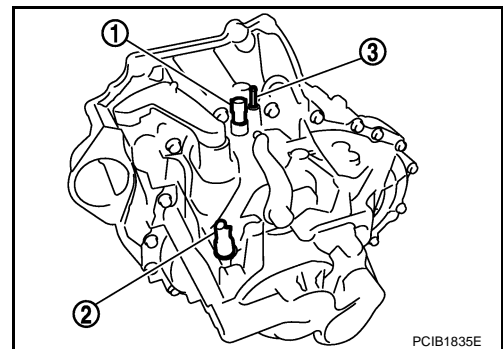

# TRANSAXLE ASSEMBLY

[RS6F52H]

## < SERVICE INFORMATION >

34. Install gasket onto plug and then install them into transaxle case. Tighten plug to the specified torque.

**CAUTION:**  
Do not reuse gasket.

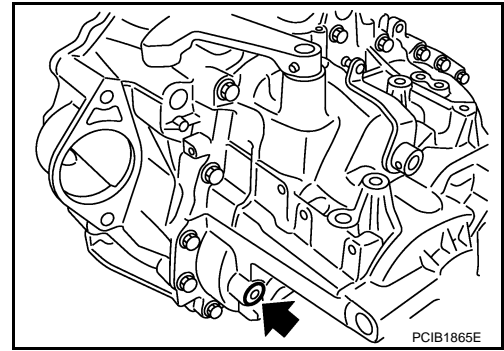

35. Install gasket onto drain plug and then install them into clutch housing. Tighten drain plug to the specified torque.

**CAUTION:**  
Do not reuse gasket.

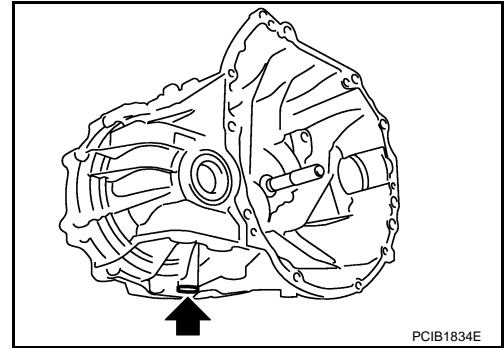

36. Install O-ring onto plug (with ABS models) or speedometer pinion gear (without ABS models) and then install it into clutch housing. Tighten bolt to the specified torque.

**CAUTION:**

- Do not reuse O-ring.
- After oil is filled, tighten bolt to specified torque.

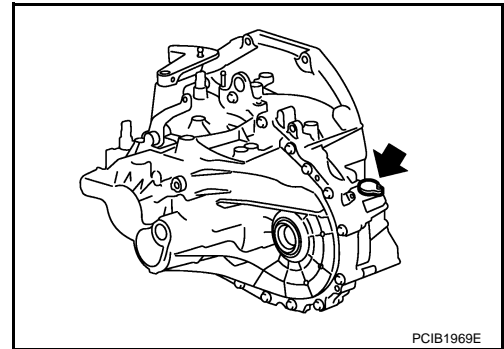

## ADJUSTMENT

### Differential Side Bearing Preload

- When adjusting differential side bearing preload, select adjusting shim for differential side bearing. To select adjusting shim, measure clearance "L" between transaxle case and differential side bearing outer race. Refer to [MT-200, "Available Shims"](#).

**CAUTION:**  
Up to 2 adjusting shims can be selected.

- Calculate dimension "L" (thickness of adjusting shim) using the following procedure to satisfy specification of preload for differential side bearing.

**Preload** : Refer to [MT-200, "Available Shims"](#).

**Dimension "L" = (L1 - L2) + Preload**

**L** : Thickness of adjusting shim

**L1** : Distance between transaxle case end face and mounting face of adjusting shim

**L2** : Distance between differential side bearing outer race and clutch housing end face

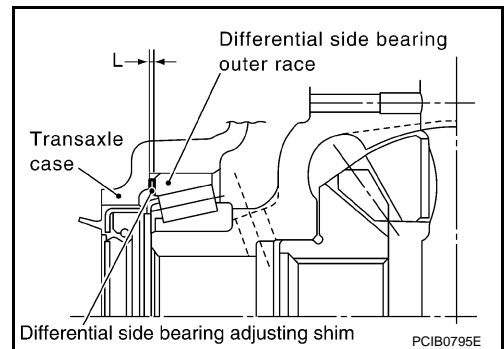

# TRANSAXLE ASSEMBLY

[RS6F52H]

## < SERVICE INFORMATION >

- Using a depth micrometer and straightedge, measure dimension "L1" between transaxle case end face and mounting face of adjusting shim.
- Install differential side bearing outer race onto differential side bearing on final gear side. Holding lightly differential side bearing outer race horizontally by hand, rotate final gear five times or more (for smooth movement of bearing roller).

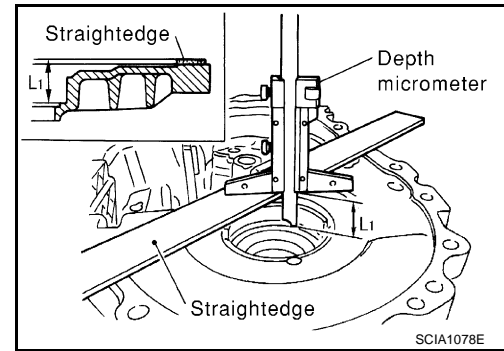

- Using a depth micrometer and straightedge as shown, measure dimension "L2" between differential side bearing outer race and clutch housing end face.

**CAUTION:**

"L2": Measure at 4 point by approximately 90 degrees and use the average value.

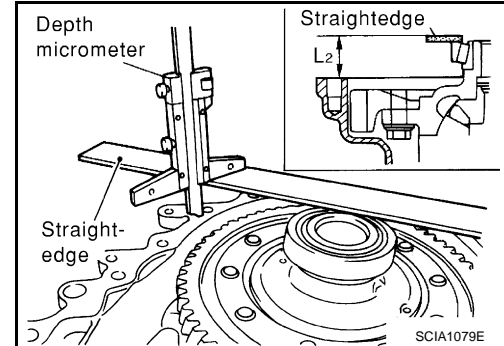

- Install selected differential side bearing adjusting shim and then install differential side bearing outer race (transaxle case side) using Tool.

**CAUTION:**

Replace differential side bearing and differential side bearing outer race as a set.

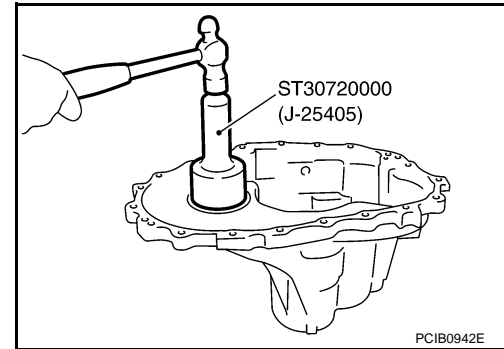

### Reverse Idler Gear End Play

- When adjusting reverse idler gear end play, select adjusting shim for reverse idler gear. To select adjusting shim (1), measure clearance between transaxle case (2) and reverse idler gear (rear) (3). Refer to [MT-199](#). "Available Adjusting Shims".

**CAUTION:**

Only 1 adjusting shim can be selected.

- Calculate dimension "Q" (thickness of adjusting shim) using the following procedure to satisfy specification of end play for reverse idler gear.

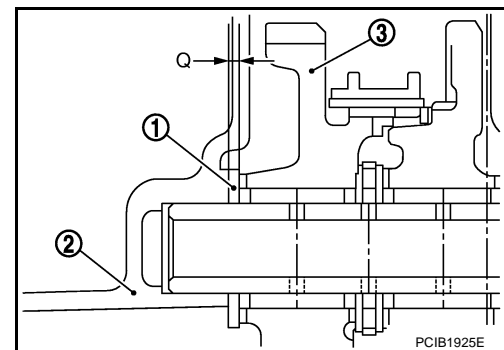

**End play** : Refer to [MT-199](#), "Available Adjusting Shims".

**Dimension "Q"** = (Q1 - Q2) - End play

**Q** : Thickness of adjusting shim

**Q1** : Distance between transaxle case end face and mounting face of adjusting shim

**Q2** : Distance between clutch housing end face and end face of reverse idler gear (rear)

# TRANSAXLE ASSEMBLY

[RS6F52H]

## < SERVICE INFORMATION >

- Using a depth micrometer and straightedge, measure dimension "Q1" between transaxle case end face and mounting face of adjusting shim.

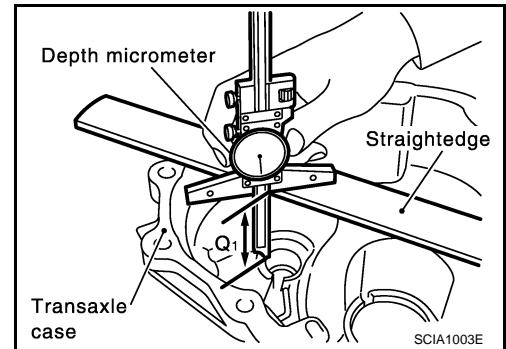

- Using a depth micrometer and straightedge as shown, measure dimension "Q2" between clutch housing (1) end face and end face of reverse idler gear (rear) (2).

**CAUTION:**

**"Q2": Measure at 4 point by approximately 90 degrees and use the average value.**

- Install selected reverse idler gear adjusting shim onto reverse idler gear (rear).

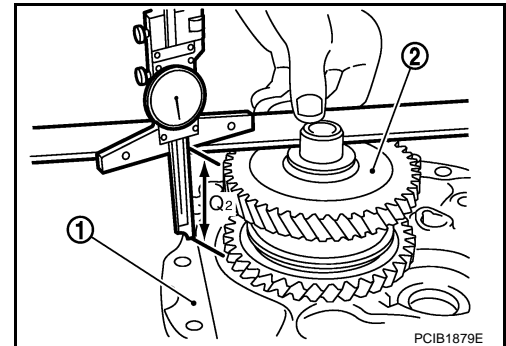

### Input Shaft End Play

- When adjusting input shaft end play, select adjusting shim for input shaft rear bearing. To select adjusting shim, measure clearance between transaxle case and input shaft rear bearing. Refer to [MT-199, "Available Adjusting Shims"](#).

**CAUTION:**

**Only 1 adjusting shim can be selected.**

- Calculate dimension "O" (thickness of adjusting shim) using the following procedure to satisfy specification of end play for input shaft rear bearing.

**End play : Refer to [MT-199, "Available Adjusting Shims"](#).**

**Dimension "O" = (O1 - O2) - End play**

**O : Thickness of adjusting shim**

**O1 : Distance between transaxle case end face and mounting face of adjusting shim**

**O2 : Distance between clutch housing end face and end face of input shaft rear bearing**

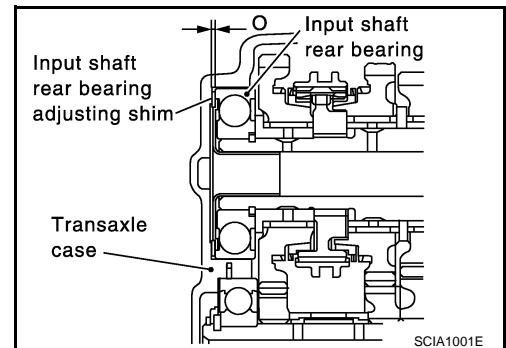

- Using a depth micrometer and straightedge, measure dimension "O1" between transaxle case end face and mounting face of adjusting shim.

**CAUTION:**

**"O1": Measure at 4 point by approximately 90 degrees and use the average value.**

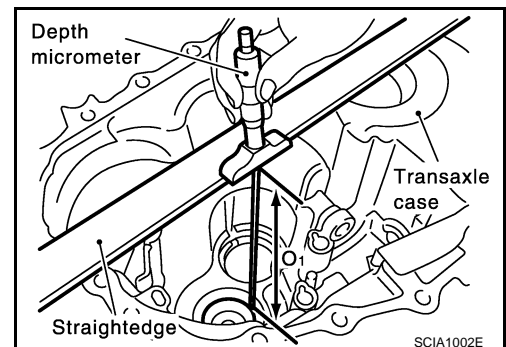



# TRANSAXLE ASSEMBLY

[RS6F52H]

## < SERVICE INFORMATION >

- Using a depth micrometer and straightedge as shown, measure dimension "O<sub>2</sub>" between clutch housing end face and end face of input shaft rear bearing.

**CAUTION:**

**"O<sub>2</sub>": Measure at 4 point by approximately 90 degrees and use the average value.**

- Install selected input shaft rear bearing adjusting shim onto input shaft.

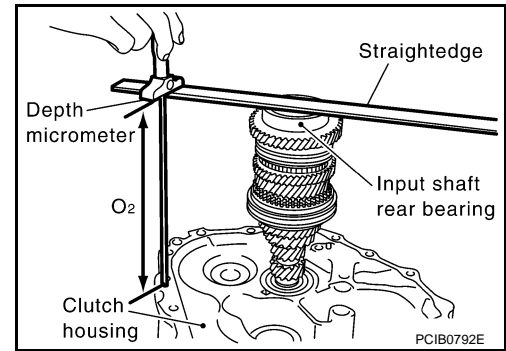

### Striking rod End Play

- When adjusting striking rod end play, select adjusting shim (1) for striking rod (2). To select adjusting shim, measure clearance between transaxle case (3) and striking rod shim (4). Refer to [MT-199, "Available Adjusting Shims"](#).

**CAUTION:**

**Only 1 adjusting shim can be selected.**

- Calculate dimension "R" (thickness of adjusting shim) using the following procedure to satisfy specification of end play for striking rod.

**End play** : Refer to [MT-199, "Available Adjusting Shims"](#).

**Dimension "R" = (R<sub>1</sub> - R<sub>2</sub>) - End play**

**R** : Thickness of adjusting shim

**R<sub>1</sub>** : Distance between transaxle case end face and mounting face of adjusting shim

**R<sub>2</sub>** : Distance between clutch housing end face and end face of striking rod shim

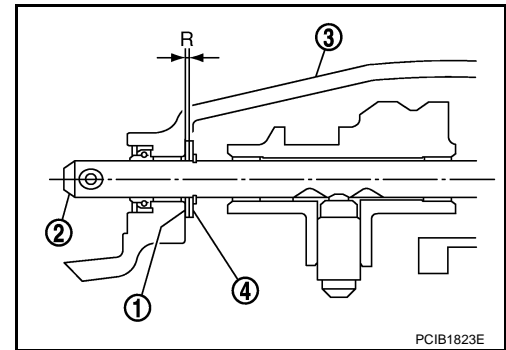

- Using a depth micrometer (A) and straightedge (B), measure dimension "R<sub>1</sub>" between transaxle case (1) end face and mounting face of adjusting shim.

**CAUTION:**

**"R<sub>1</sub>": Measure at 4 point by approximately 90 degrees and use the average value.**

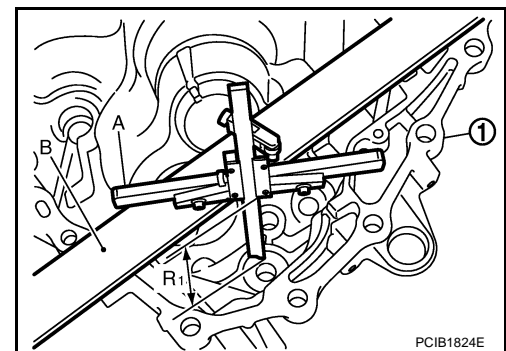

- Using a depth micrometer (A) and straightedge (B) as shown, measure dimension "R<sub>2</sub>" between clutch housing (1) end face and end face of striking rod shim (2).

**CAUTION:**

**"R<sub>2</sub>": Measure at 4 point by approximately 90 degrees and use the average value.**

**When measuring, be careful for the inclination of striking rod assembly and striking rod shim.**

- Install selected striking rod adjusting shim onto striking rod assembly.

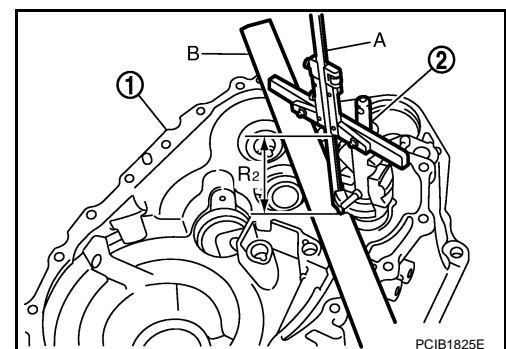

### Mainshaft End Play

# TRANSAXLE ASSEMBLY

[RS6F52H]

## < SERVICE INFORMATION >

- When adjusting mainshaft end play, select adjusting shim (1) for mainshaft rear bearing (2). To select adjusting shim, measure clearance "M" between transaxle case (3) and dummy adjusting shim (4) on mainshaft rear bearing. Refer to [MT-199, "Available Adjusting Shims"](#).

5 : Snap ring

6 : Mainshaft

### CAUTION:

**Only 1 adjusting shim can be selected.**

- Calculate dimension "P" (thickness of adjusting shim) using the following procedure to satisfy specification of end play for mainshaft rear bearing.

**End play** : Refer to [MT-199, "Available Adjusting Shims"](#).

**Dimension "P"** = (M + N) - End play

**P** : Thickness of adjusting shim

**M** : Distance between dummy adjusting shim on mainshaft rear bearing end face and transaxle case end face

**N\*** : Thickness of dummy adjusting shim

\*: Refer to the latest parts information to use a dummy adjusting shim of which part number is the thinnest in thickness. Refer to [MT-199, "Available Adjusting Shims"](#).

- Install transaxle case following the procedures below.
  - Temporarily install snap ring of mainshaft rear bearing into transaxle case.

### CAUTION:

**Do not reuse snap ring.**

- Install dummy adjusting shim (1) to mainshaft assembly.

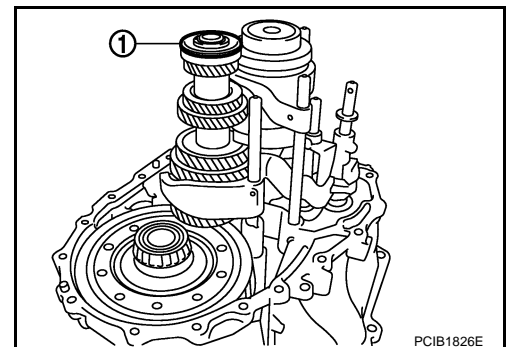
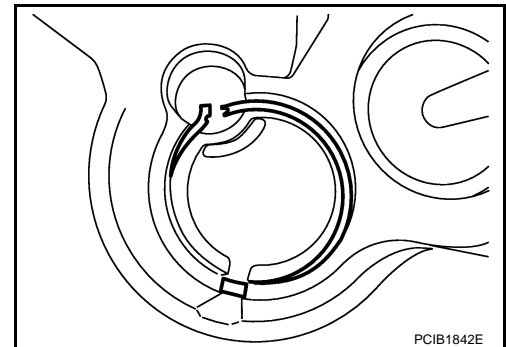
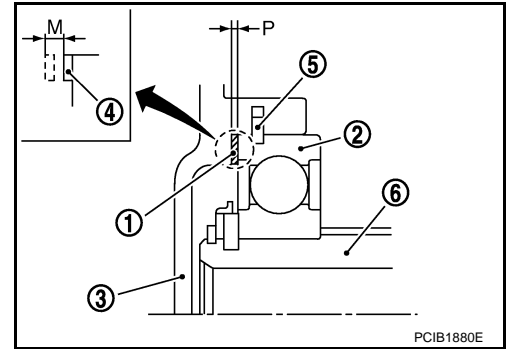

# TRANSAXLE ASSEMBLY

[RS6F52H]

## < SERVICE INFORMATION >

- c. With shifter lever A (1) held in the position shown, temporarily assemble transaxle case to clutch housing.

**CAUTION:**

**Do not damage striking rod oil seal.**

**NOTE:**

Make sure to hold shifter lever A in the position shown. Otherwise transaxle case cannot be installed to clutch housing.

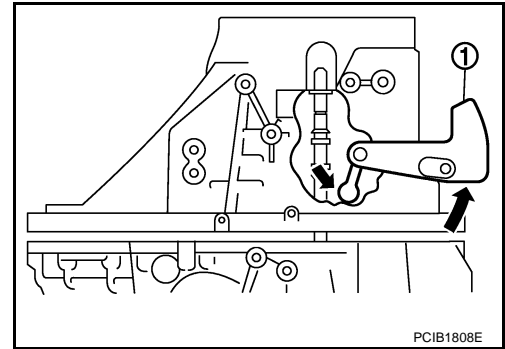

- d. While rotating shifter lever A (1) in the direction of the arrow shown, assemble transaxle case to clutch housing.

2 : shifter lever B

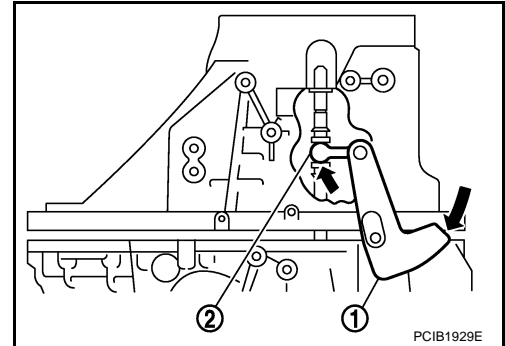

- e. Accessing from the bore plug hole, expand snap ring at mainshaft rear bearing so that the ring catches the periphery of mainshaft rear bearing.

- f. Temporarily tighten transaxle case bolts.

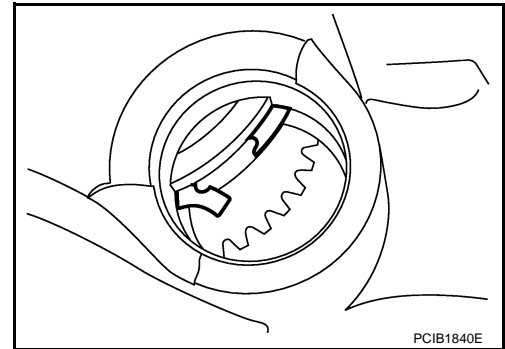

2. Shift the shifter lever A to 2nd gear position.

**NOTE:**

- The 2nd gear position is attained when shifter lever A (1) is in the position shown.

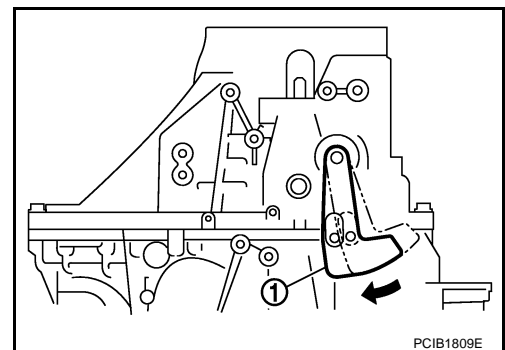

- When transaxle is shifted to the 2nd gear position, mainshaft assembly (1) is lifted.

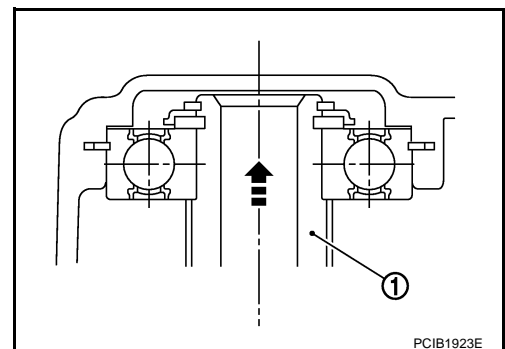

A  
B  
MT  
D  
E  
F  
G  
H  
I  
J  
K  
L  
M  
N  
O  
P

# TRANSAXLE ASSEMBLY

[RS6F52H]

## < SERVICE INFORMATION >

3. Seat snap ring in the groove on mainshaft rear bearing. If snap ring is not seated in the groove on mainshaft rear bearing, remove transaxle case and repeat the procedure 1 from step c.
4. Shift the shifter lever A to 1st gear position, and then shift it to 2nd gear position. Repeat 3 times.

**NOTE:**

- The mainshaft rear bearing position will be stabilized by shifting between 1st gear position and 2nd gear position alternately.
- The 1st gear position is attained when shifter lever A (1) is in the position shown.

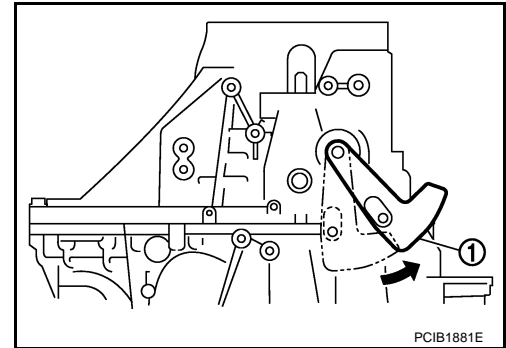

- When transaxle is shifted to the 1st gear position, mainshaft assembly (1) is declined.

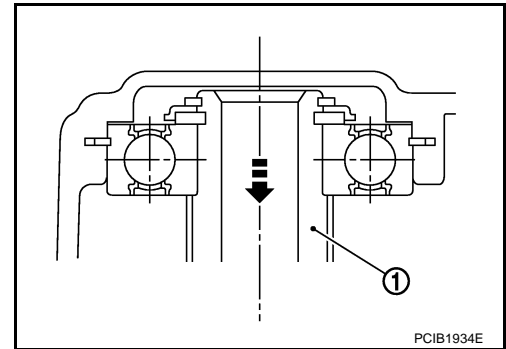

5. Set the dial indicator (A) to dummy adjusting shim (1) through the bore plug mounting hole.

- 2 : Mainshaft rear bearing
- 3 : Snap ring

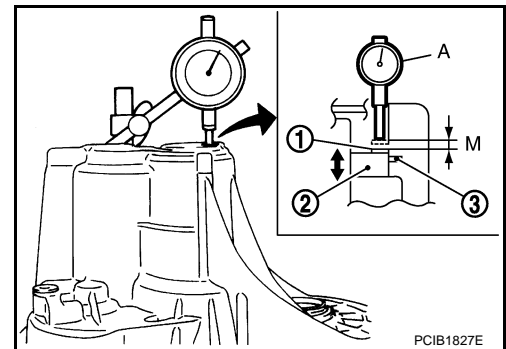

# TRANSAXLE ASSEMBLY

[RS6F52H]

## < SERVICE INFORMATION >

- Shift the shifter lever A (1) to 2nd gear position (A), and then rotate it in the direction of the arrow (C) shown until it stops. Using this position as the reference point, measure the amount of movement when shifting shifter lever A to 1st gear position (B) and rotating it in the direction of the arrow (D) shown until it stops. This measurement is the "M" dimension.
- When measurement "M" is 0 - 0.06 mm (0 - 0.0024 in), adjustment terminates, and the dummy adjusting shim becomes regular adjusting shim. Select adjusting shim from the computed expressions when measurement "M" is over 0.06 mm (0.0024 in).

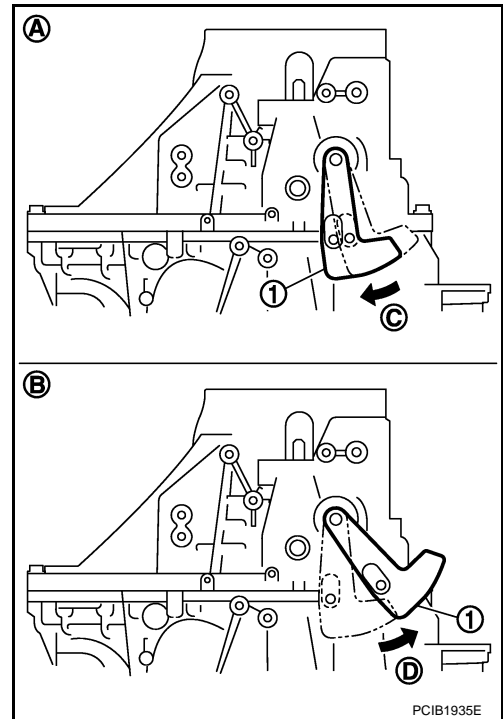

A  
B  
MT  
D  
E  
F  
G  
H  
I  
J  
K  
L  
M  
N  
O  
P

## INPUT SHAFT AND GEARS

### Disassembly and Assembly

INFOID:000000001850916

#### DISASSEMBLY

1. Before disassembling, measure end play for 3rd, 4th, 5th, and 6th input gears.

**End play standard value**

**: Refer to [MT-197, "Gear End Play"](#).**

2. Remove oil channel.

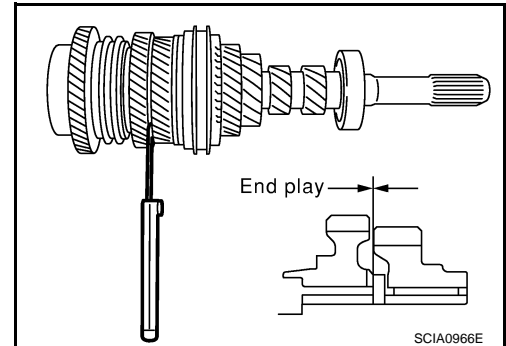

3. Press out input shaft rear bearing using Tool and a puller.
4. Remove snap ring.

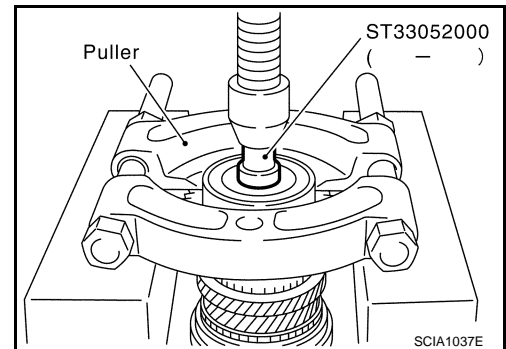

5. Press out 6th input gear, 6th needle bearing, 6th input gear bushing, 5th-6th synchronizer hub assembly, and 5th input gear using Tool (A) and a puller (B).

**Tool number     A: ST33052000 ( — )**

6. Remove 5th needle bearing.

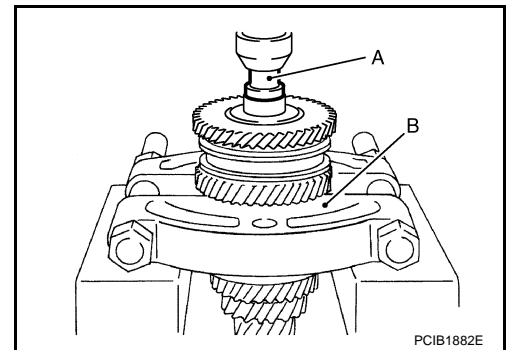

7. Press out 5th input gear bushing, thrust washer, 4th input gear, 4th needle bearing, 4th input gear bushing, 3rd-4th synchronizer hub assembly, and 3rd input gear using Tool and a puller.

8. Remove 3rd needle bearing.

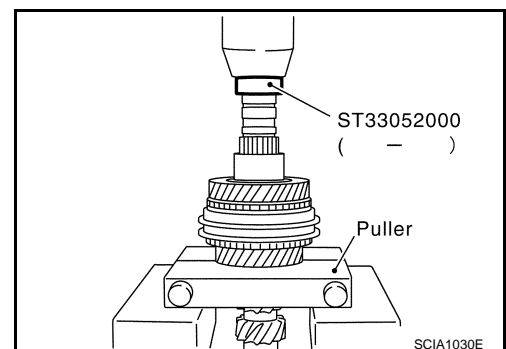

# INPUT SHAFT AND GEARS

[RS6F52H]

## < SERVICE INFORMATION >

9. Press out input shaft front bearing using a puller.

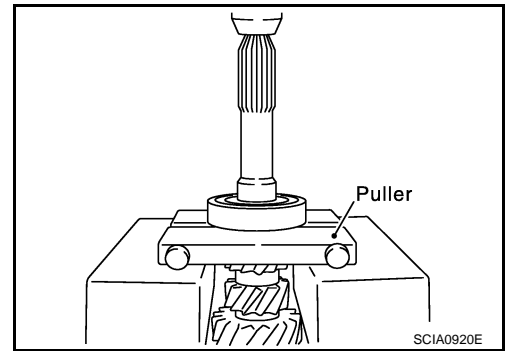

## INSPECTION AFTER DISASSEMBLY

### Input Shaft and Gears

Check items below. If necessary, replace them with new ones.

- Damage, peeling, dent, uneven wear, bending, etc. of shaft
- Excessive wear, damage, peeling, etc. of gears

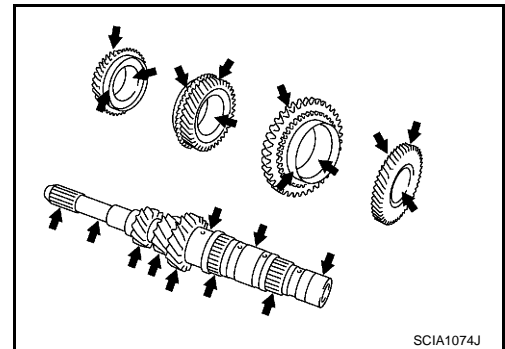

### Synchronizer

Check items below. If necessary, replace them with new ones.

- Damage and excessive wear of contact surfaces of coupling sleeve, synchronizer hub and shifting insert
- Coupling sleeve and synchronizer hub must move smoothly.

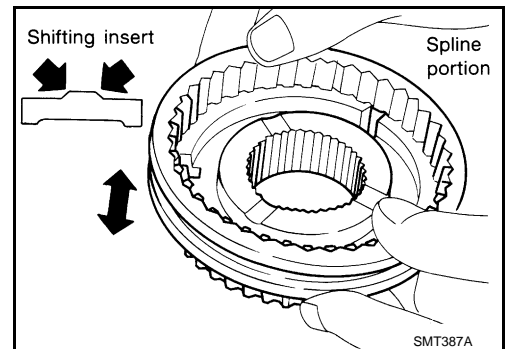

- If any crack, damage, or excessive wear is found on cam face of baulk ring or working face of insert, replace it.

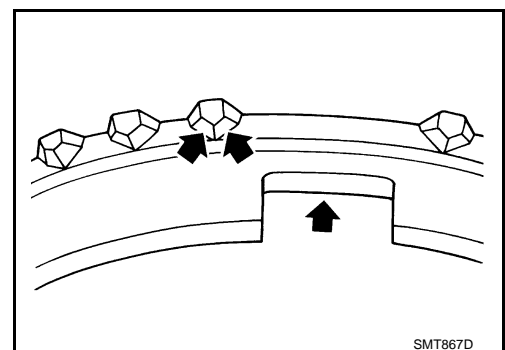

## BAULK RING CLEARANCE

- Single-cone synchronizer (4th, 5th, and 6th)

A  
B  
MT  
D  
E  
F  
G  
H  
I  
J  
K  
L  
M  
N  
O  
P

# INPUT SHAFT AND GEARS

[RS6F52H]

## < SERVICE INFORMATION >

Push baulk ring on the cone and measure the clearance between baulk ring and cone. If measurement is below limit, replace it with a new one.

### Clearance

**Standard value** : Refer to [MT-197, "Baulk Ring Clearance"](#).

**Limit value** : Refer to [MT-197, "Baulk Ring Clearance"](#).

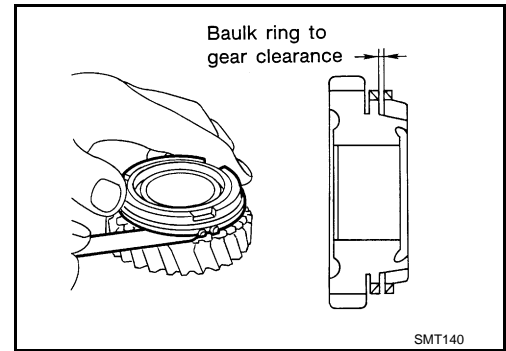

### • Double-cone synchronizer (3rd)

Check the clearance between outer baulk ring, synchronizer cone, and inner baulk ring as follows.

#### CAUTION:

The clearances "A" and "B" are controlled with outer baulk ring, synchronizer cone, and inner baulk ring as a set. Replace them as a set if the clearances are outside the limit value.

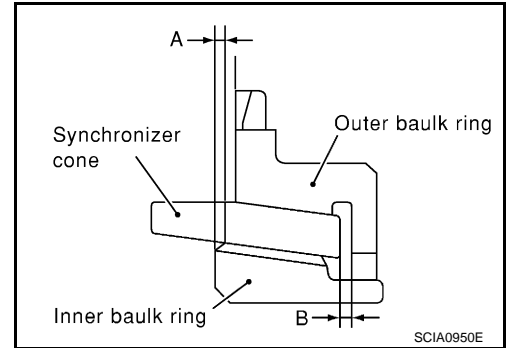

1. Measure the clearance "A" at 2 points or more diagonally opposite using a dial indicator. And then calculate mean value.

### Clearance "A"

**Standard value** : Refer to [MT-197, "Baulk Ring Clearance"](#).

**Limit value** : Refer to [MT-197, "Baulk Ring Clearance"](#).

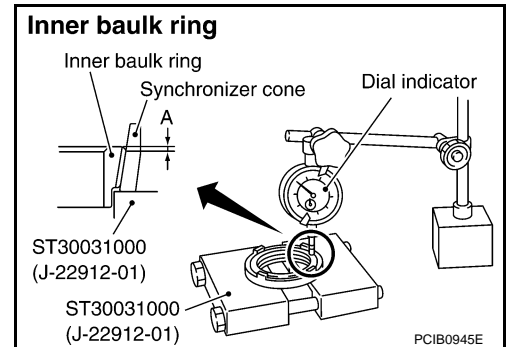

2. Measure the clearance "B" at 2 points or more diagonally opposite using a feeler gauge. And then calculate mean value.

### Clearance "B"

**Standard value** : Refer to [MT-197, "Baulk Ring Clearance"](#).

**Limit value** : Refer to [MT-197, "Baulk Ring Clearance"](#).

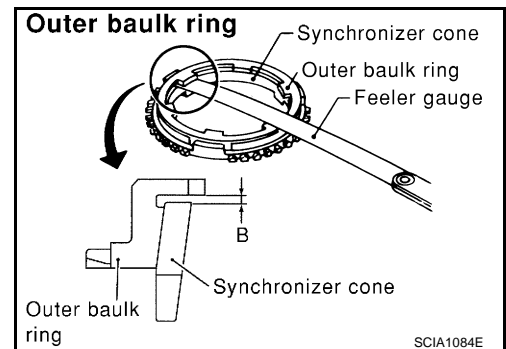

Bearing



# INPUT SHAFT AND GEARS

[RS6F52H]

## < SERVICE INFORMATION >

Check items below. If necessary, replace them with new ones.

- Damage and rough rotation of bearing

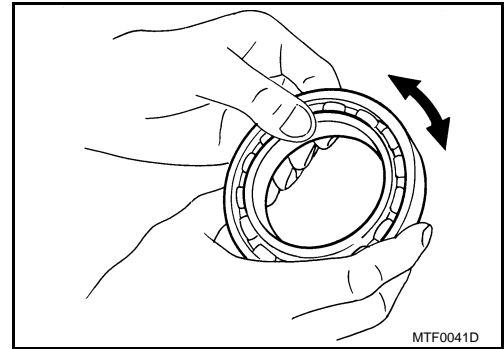

A

B

MT

D

## ASSEMBLY

1. Install 3rd needle bearing to input shaft.
2. Install 3rd input gear, 3rd inner baulk ring, 3rd synchronizer cone, and 3rd outer baulk ring to input shaft.  
**CAUTION:**  
**Replace 3rd inner baulk ring, 3rd synchronizer cone, and 3rd outer baulk ring as a set.**
3. Install 3rd-4th spread springs, 3rd-4th shifting inserts, and 3rd-4th synchronizer hub onto 3rd-4th coupling sleeve.

E

F

### **CAUTION:**

- Be careful with orientation of 3rd-4th synchronizer hub.
- Do not reuse 3rd-4th synchronizer hub and 3rd-4th coupling sleeve.
- Replace 3rd-4th synchronizer hub and 3rd-4th coupling sleeve as a set.

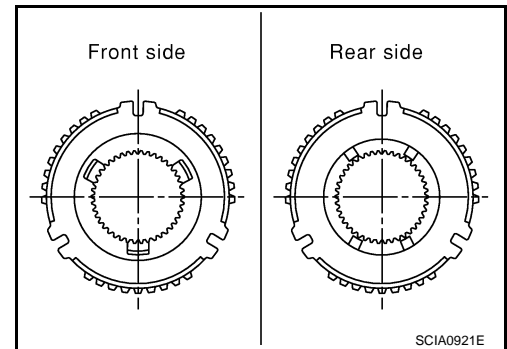

G

H

I

J

- Be careful with orientation of 3rd-4th coupling sleeve.

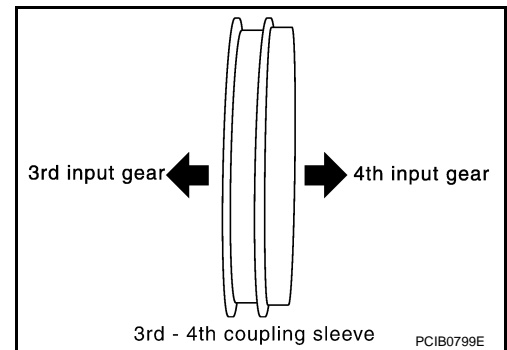

K

L

M

- Be sure not to hook center projection of 2 spread springs on same shifting insert.

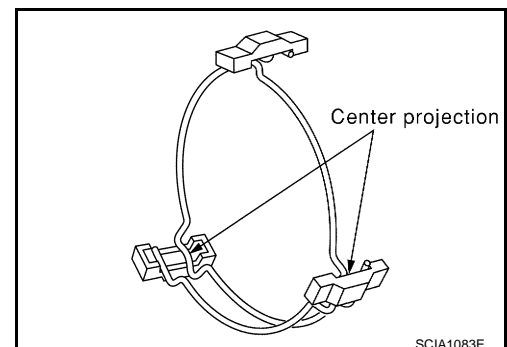

N

O

P

# INPUT SHAFT AND GEARS

[RS6F52H]

< SERVICE INFORMATION >

4. Press in 3rd-4th synchronizer hub assembly using Tool.

**CAUTION:**

Align grooves of 3rd-4th shifting insert and 3rd outer baulk ring.

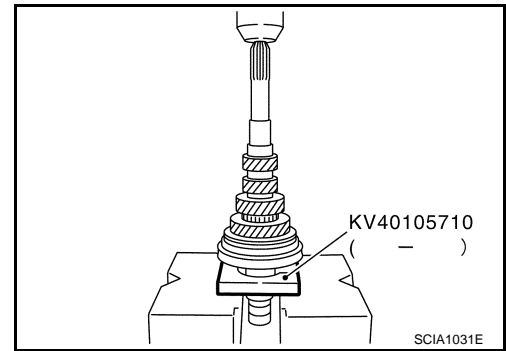

5. Press in 4th input gear bushing using Tool.  
6. Install 4th baulk ring.  
7. Install 4th needle bearing and 4th input gear to input shaft.

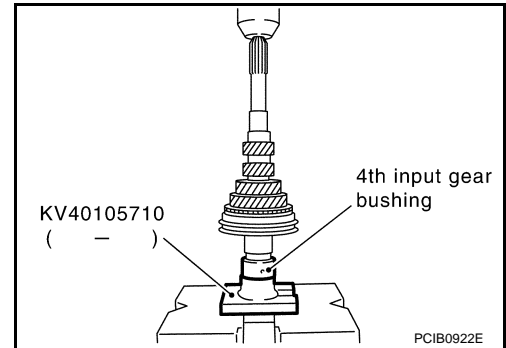

8. Select thrust washer so that dimension "C2" satisfies the standard value below. Then install thrust washer onto input shaft. Refer to [MT-198, "Available Thrust Washer"](#).

**Standard value for dimension "C2"**

**: Refer to [MT-198, "Available Thrust Washer"](#).**

**CAUTION:**

**Only one thrust washer can be selected.**

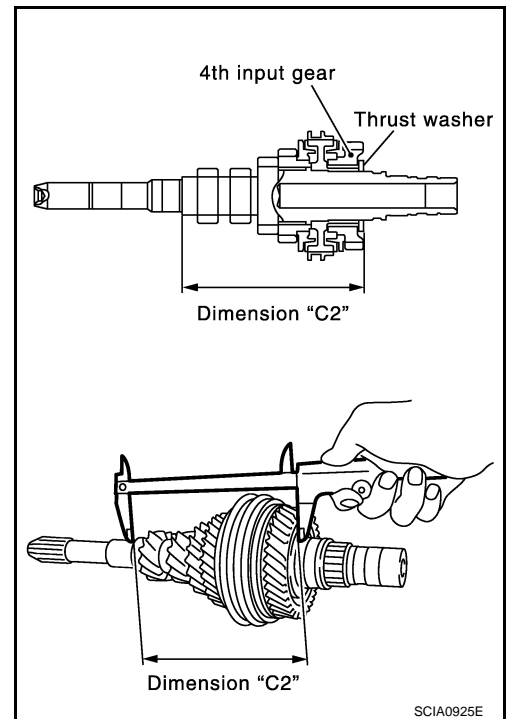

9. Press in 5th input gear bushing using Tool.  
**CAUTION:**  
**Do not reuse 5th input gear bushing.**  
10. Install 5th needle bearing and 5th input gear to input shaft.  
11. Install 5th baulk ring.

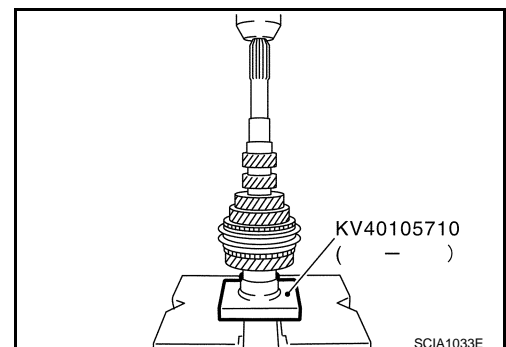

# INPUT SHAFT AND GEARS

[RS6F52H]

## < SERVICE INFORMATION >

12. Install 5th-6th synchronizer hub, 5th-6th spread springs, and 5th-6th shifting inserts onto 5th-6th coupling sleeve.

**CAUTION:**

- Be careful with orientation of 5th-6th synchronizer hub.

A : Front side

B : Rear side

- Do not reuse 5th-6th synchronizer hub and 5th-6th coupling sleeve.
- Replace 5th-6th synchronizer hub and 5th-6th coupling sleeve as a set.

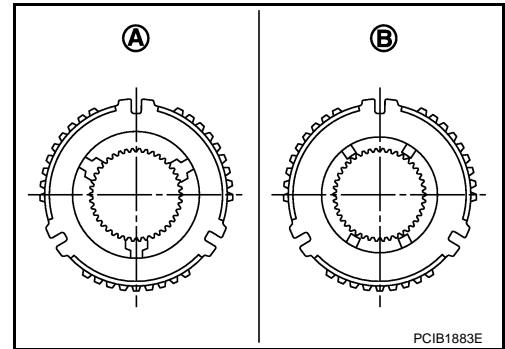

- Be careful with orientation of 5th-6th coupling sleeve.

A : 5th input gear side

B : 6th input gear side

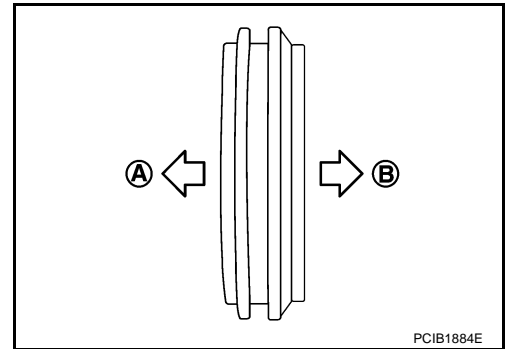

- Be sure not to hook center projection of 2 spread springs on same shifting insert.

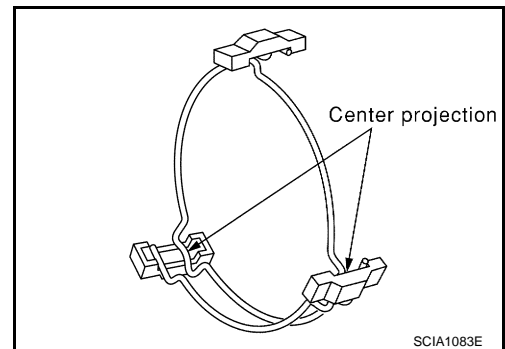

13. Press in 5th-6th synchronizer hub assembly using Tool.

**CAUTION:**

- Align grooves of 5th-6th shifting insert and 5th baulk ring.

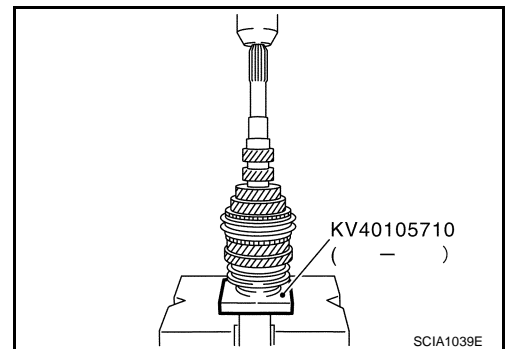

A  
B  
MT  
D  
E  
F  
G  
H  
I  
J  
K  
L  
M  
N  
O  
P

# INPUT SHAFT AND GEARS

[RS6F52H]

## < SERVICE INFORMATION >

14. Install 6th needle bearing, 6th input gear, 6th baulk ring onto 6th input gear bushing and then press in 6th input gear bushing onto input shaft using Tool.

**Tool number**      **A: ST33200000 (J-26082)**

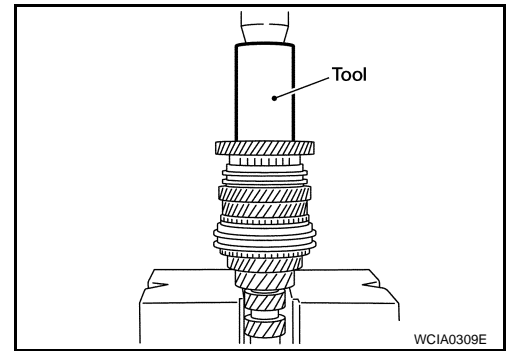

15. Install snap ring onto input shaft and make sure that end play (gap between snap ring and groove) of 6th input gear bushing satisfies the standard value.

**End play standard value**

**:Refer to [MT-197, "Available Snap Rings"](#).**

- If measurement is outside the standard range, select snap ring. Refer to [MT-197, "Available Snap Rings"](#).

**CAUTION:**

**Do not reuse snap ring.**

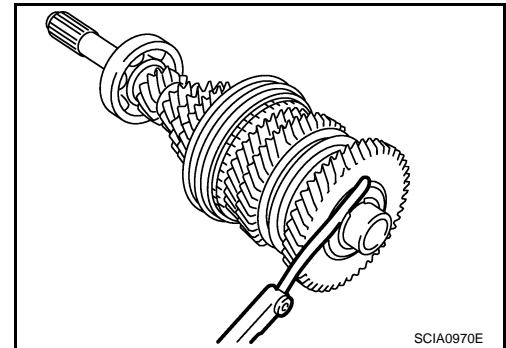

16. Press in input shaft rear bearing using Tool.

**Tool number**      **A: ST30901000 (J-26010-01)**

**CAUTION:**

**Install input shaft rear bearing with its brown surface facing the 6th input gear side.**

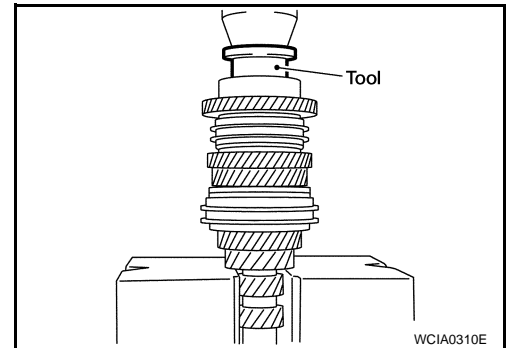

17. Press in input shaft front bearing using Tools.

**Tool number**      **A: ST33052000 ( — )**

**B: ST30032000 (J-26010-01)**

18. Install oil channel onto input shaft.

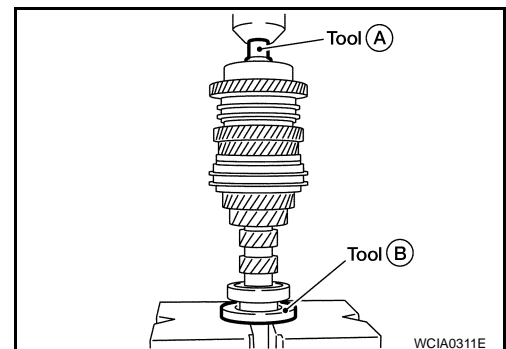

19. Check end play of 3rd, 4th, 5th, and 6th input gears.

**End play standard value**

**: Refer to [MT-197, "Gear End Play"](#).**

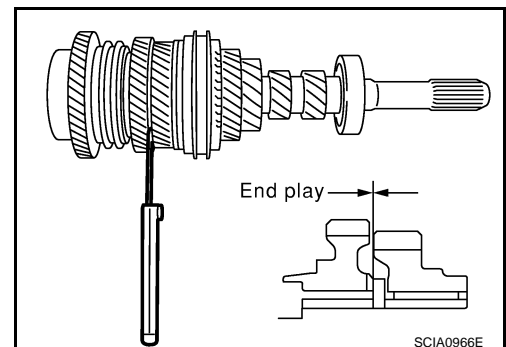

## MAINSHAFT AND GEARS

### Disassembly and Assembly

INFOID:000000001850917

#### DISASSEMBLY

1. Before disassembling, measure the end play of 1st and 2nd main gears.

**End play standard value**

: Refer to [MT-197, "Gear End Play"](#).

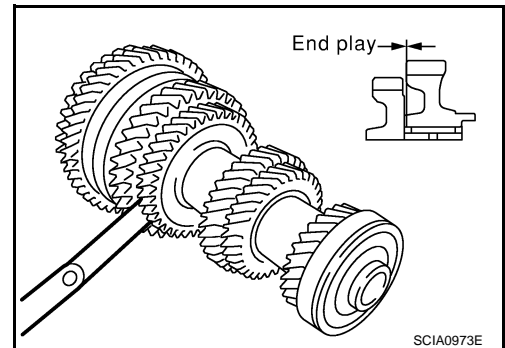

2. Remove snap ring.
3. Remove C-ring holder and then remove mainshaft C-rings.

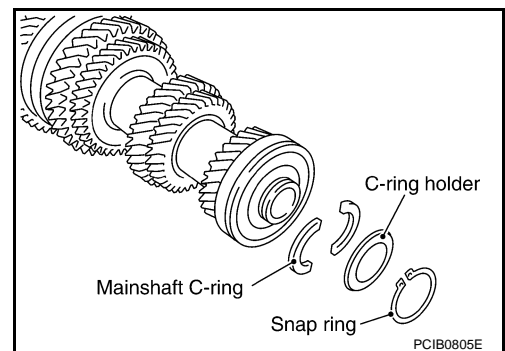

4. Press out mainshaft rear bearing, 6th main gear adjusting shim, and 6th main gear using Tool and a puller.
5. Remove 5th-6th mainshaft spacer.

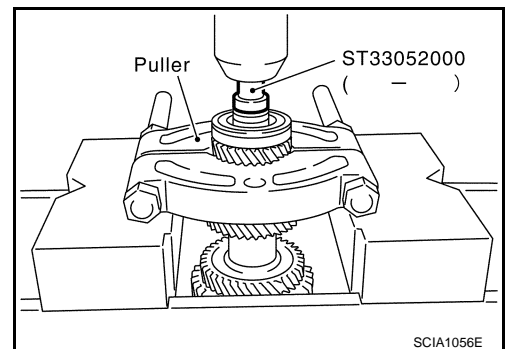

6. Press out 4th main gear and 5th main gear using Tool and a puller.
7. Remove 4th main gear adjusting shim.
8. Remove 3rd-4th mainshaft spacer.

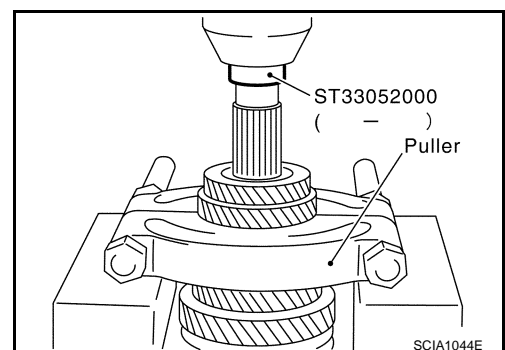

A  
B  
MT  
D  
E  
F  
G  
H  
I  
J  
K  
L  
M  
N  
O  
P

# MAINSHAFT AND GEARS

[RS6F52H]

## < SERVICE INFORMATION >

9. Press out 3rd main gear and 2nd main gear using Tool (A) and a puller (B).

**Tool number**      **A: KV40105020 ( — )**

10. Remove 2nd needle bearing.

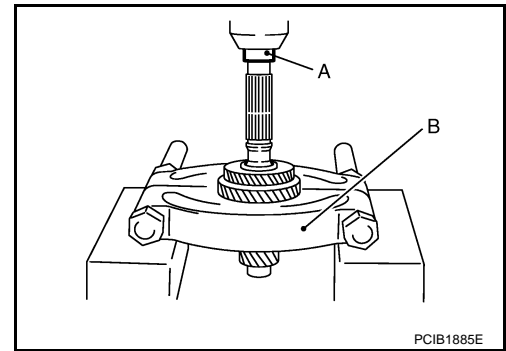

11. Press out 2nd main gear bushing, 1st-2nd synchronizer hub assembly, 1st main gear, 1st needle bearing, 1st main gear bushing, and reverse main gear using Tool (A).

**Tool number**      **A: KV40105020 ( — )**

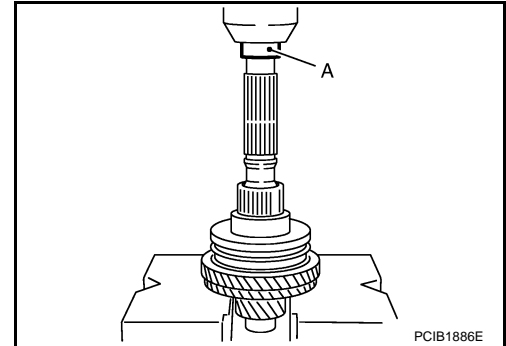

## INSPECTION AFTER DISASSEMBLY

### Mainshaft and Gears

Check items below. If necessary, replace them with new ones.

- Damage, peeling, dent, uneven wear, bending, and other non-standard conditions of the shaft.
- Excessive wear, damage, peeling, and other non-standard conditions of the gears.

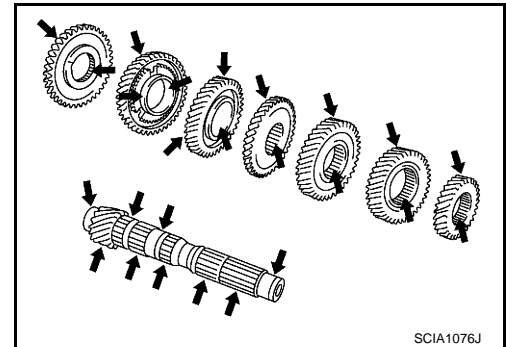

### Synchronizer

Check items below. If necessary, replace them with new ones.

- Damage and unusual wear on contact surfaces of coupling sleeve, synchronizer hub and shifting insert.
- Coupling sleeve and synchronizer hub must move smoothly.

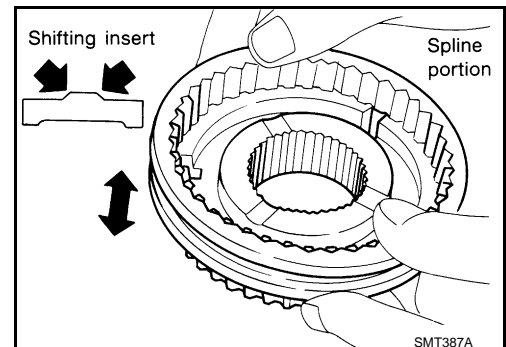

# MAINSHAFT AND GEARS

[RS6F52H]

## < SERVICE INFORMATION >

- If any crack, damage, or excessive wear is found on cam face of baulk ring or working face of insert, replace it.

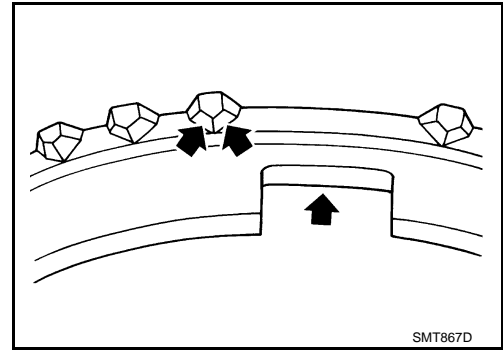

## BAULK RING CLEARANCE

### Triple-cone synchronizer (1st and 2nd)

- Check the clearance between outer baulk ring, synchronizer cone, and inner baulk ring as follows.

#### CAUTION:

The clearances "A", "B", and "C" are controlled with outer baulk ring, synchronizer cone, and inner baulk ring as a set. Replace them as a set if the clearances are outside the limit value.

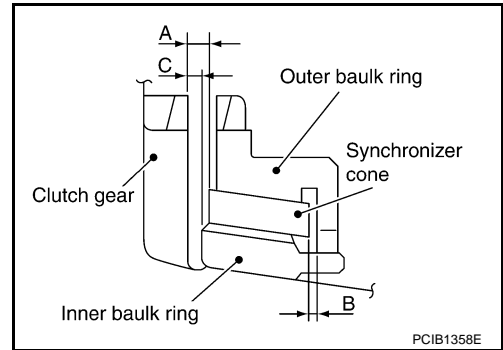

1. Measure the clearance "A" at 2 points or more diagonally opposite using a feeler gauge when pressing baulk ring toward clutch gear taper cone. And then calculate mean value.

#### Clearance "A"

Standard value : Refer to [MT-197, "Baulk Ring Clearance"](#).

Limit value : Refer to [MT-197, "Baulk Ring Clearance"](#).

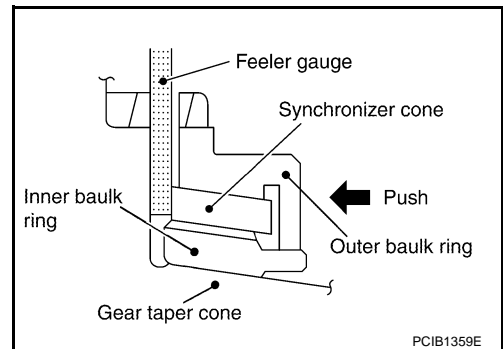

2. Measure the clearance "B" at 2 points or more diagonally opposite using a feeler gauge. And then calculate mean value.

#### Clearance "B"

Standard value : Refer to [MT-197, "Baulk Ring Clearance"](#).

Limit value : Refer to [MT-197, "Baulk Ring Clearance"](#).

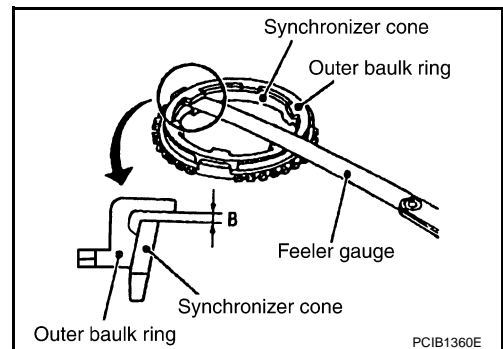

# MAINSHAFT AND GEARS

[RS6F52H]

## < SERVICE INFORMATION >

3. Measure the clearance "C" at 2 points or more diagonally opposite using a feeler gauge when pressing baulk ring toward clutch gear taper cone. And then calculate mean value.

### Clearance "C"

**Standard value** : Refer to [MT-197, "Baulk Ring Clearance"](#).

**Limit value** : Refer to [MT-197, "Baulk Ring Clearance"](#).

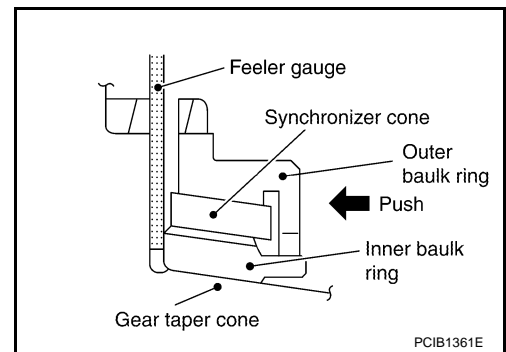

### Bearing

Check items below. If necessary, replace them with new ones.

- Damage and rough rotation of bearing

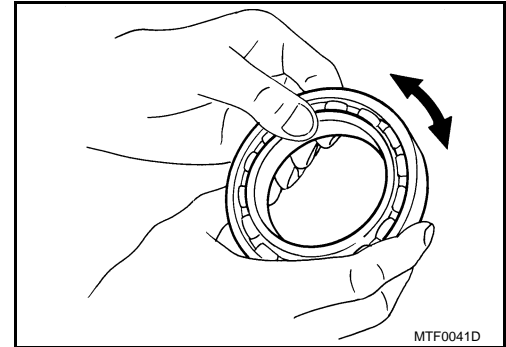

## ASSEMBLY

1. Press in reverse main gear using Tools.

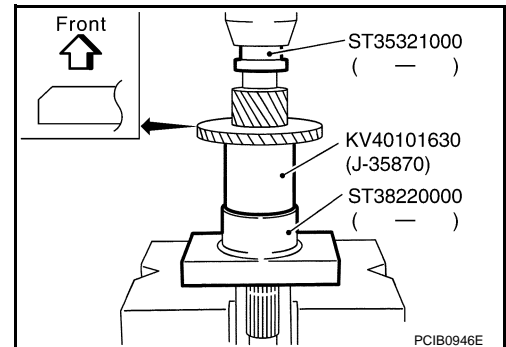

### CAUTION:

- Be careful with orientation of reverse main gear.
- Do not reuse reverse main gear.

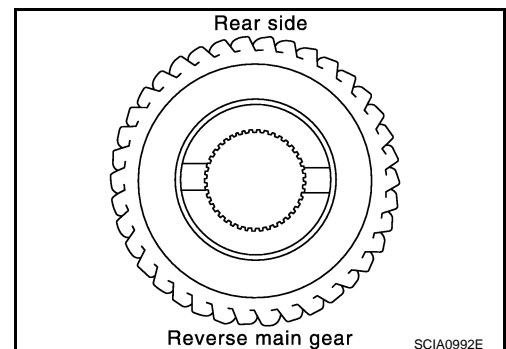



# MAINSHAFT AND GEARS

[RS6F52H]

## < SERVICE INFORMATION >

2. Press in 1st main gear bushing using Tools.
3. Install 1st needle bearing and then 1st main gear.

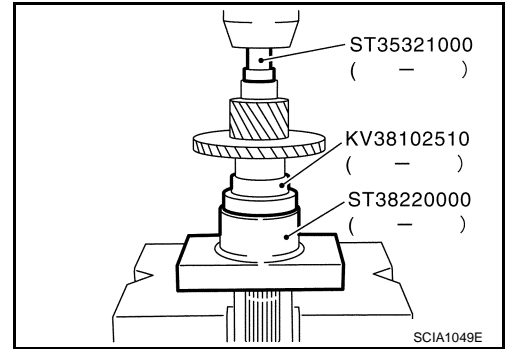

4. Install 1st-2nd spread springs, 1st-2nd shifting inserts, and 1st-2nd synchronizer hub onto 1st-2nd coupling sleeve.

**CAUTION:**

- Be careful with orientation of 1st-2nd synchronizer hub.
- Do not reuse 1st-2nd synchronizer hub and 1st-2nd coupling sleeve.
- Replace 1st-2nd synchronizer hub and 1st-2nd coupling sleeve as a set.

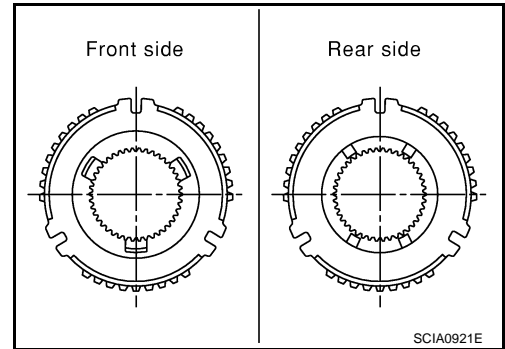

- Be careful with orientation of 1st-2nd coupling sleeve.

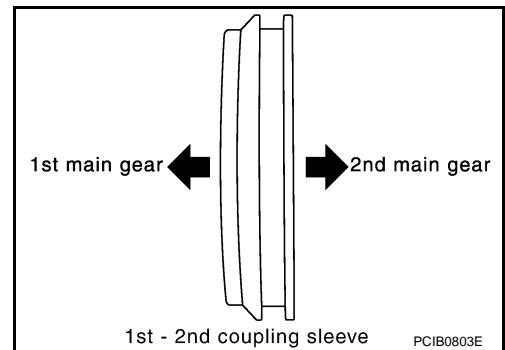

- Be sure not to hook center projection of 2 spread springs on same 1st-2nd shifting insert.

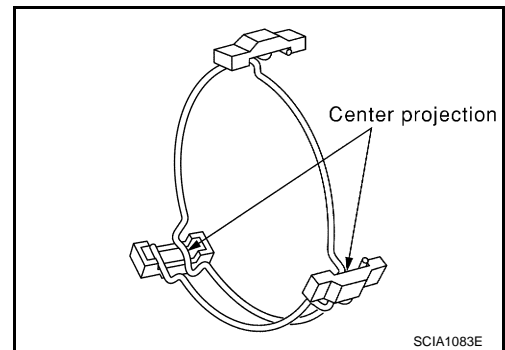

A  
B  
MT  
D  
E  
F  
G  
H  
I  
J  
K  
L  
M  
N  
O  
P

# MAINSHAFT AND GEARS

[RS6F52H]

< SERVICE INFORMATION >

5. Install 1st inner baulk ring, 1st synchronizer cone, and 1st outer baulk ring onto mainshaft and then press in 1st-2nd synchronizer hub assembly onto mainshaft using Tools.

**CAUTION:**

- Outer baulk ring, synchronizer cone, and inner baulk ring on 2nd gear-side must have been removed.
- Be careful with orientation of coupling sleeve.
- Replace 1st inner baulk ring, 1st synchronizer cone, and 1st outer baulk ring as a set.

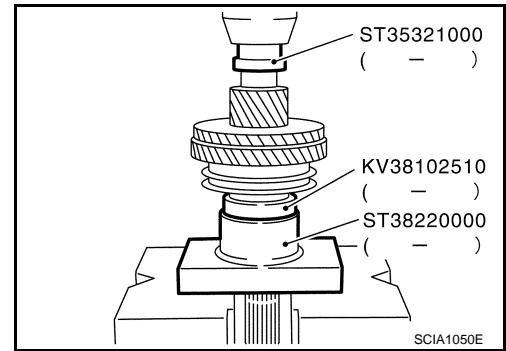

6. Press in 2nd main gear bushing using Tools.
7. Install 2nd outer baulk ring, 2nd synchronizer cone, and 2nd inner baulk ring.

**CAUTION:**

- Replace 2nd outer baulk ring, 2nd synchronizer cone, and 2nd inner baulk ring as a set.

8. Install 2nd needle bearing and 2nd main gear.

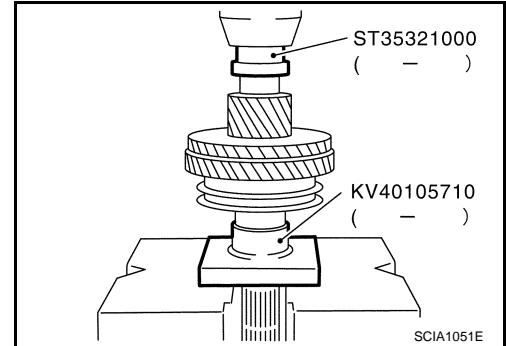

9. Press in 3rd main gear using Tools.

**CAUTION:**

- Be careful with orientation of 3rd main gear.
- Do not reuse 3rd main gear.

10. Install 3rd-4th mainshaft spacer.

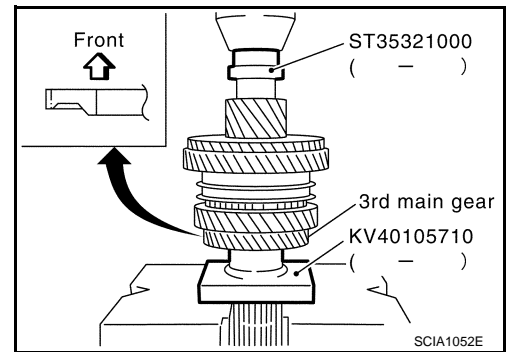

11. Select 4th main gear adjusting shim so that dimension "C1" satisfies the standard value below and install 4th main gear adjusting shim onto mainshaft. Refer to [MT-199, "Available Adjusting Shims"](#).

**Standard value for dimension "C1"**

**: Refer to [MT-199, "Available Adjusting Shims"](#).**

**CAUTION:**

**Only one adjusting shim can be selected.**

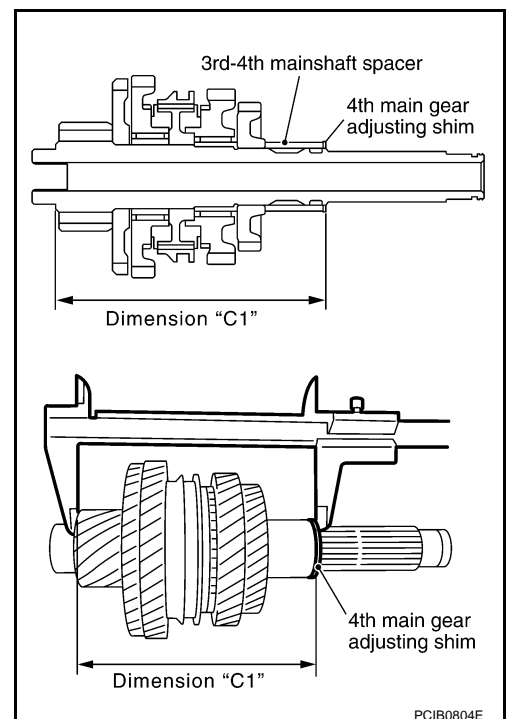

# MAINSHAFT AND GEARS

[RS6F52H]

< SERVICE INFORMATION >

12. Press in 4th main gear using Tools.

**CAUTION:**

- Be careful with orientation of 4th main gear.
- Do not reuse 4th main gear.

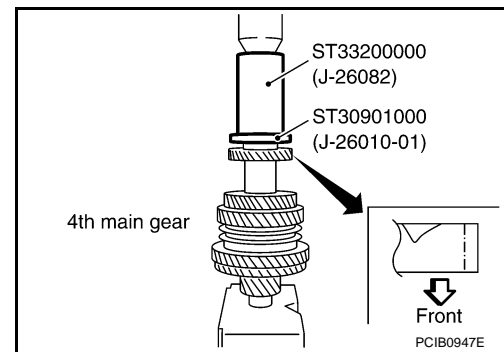

13. Press in 5th main gear using Tools.

**CAUTION:**

- Be careful with orientation of 5th main gear.
- Do not reuse 5th main gear.

14. Install 5th-6th mainshaft spacer.

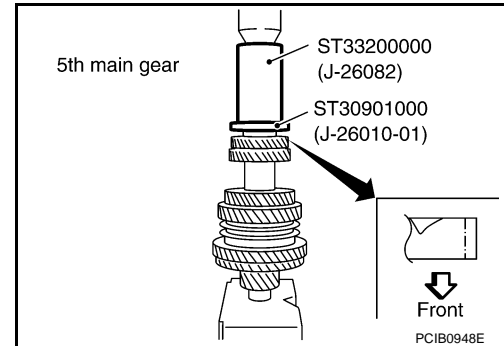

15. Press in 6th main gear using Tools (A), (B).

- Tool number**
- A:** ST33200000 (J-26082)
  - B:** ST30901000 (J-26010-01)

**CAUTION:**

Do not reuse 6th main gear.

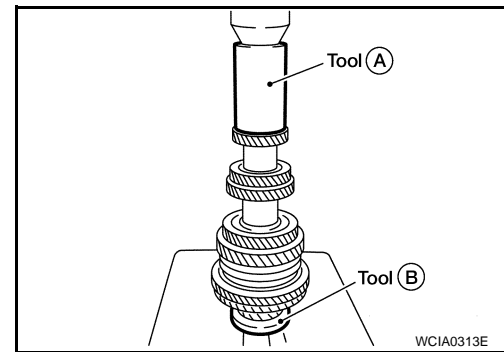

16. Select 6th main gear adjusting shim and then install it onto mainshaft.

- Calculate thickness "S" of 6th main gear adjusting shim following the procedure below so that end play dimension between 6th main gear and mainshaft rear bearing becomes the dimension shown below. Refer to [MT-199, "Available Adjusting Shims"](#).

**End play** :Refer to [MT-199, "Available Adjusting Shims"](#).

**Dimension "S"** = (S<sub>1</sub> - S<sub>2</sub>) - End play

**S** : Thickness of adjusting shim

**S<sub>1</sub>** : Dimension from mainshaft standard face to mainshaft rear bearing press-fit end face

**S<sub>2</sub>** : Dimension from mainshaft standard face to 6th main gear end face

**CAUTION:**

Only one adjusting shim can be selected.

- Measure dimension "S<sub>1</sub>" and "S<sub>2</sub>" using a height gauge (A) and pick tester (B).
- Install selected 6th main gear adjusting shim to mainshaft.

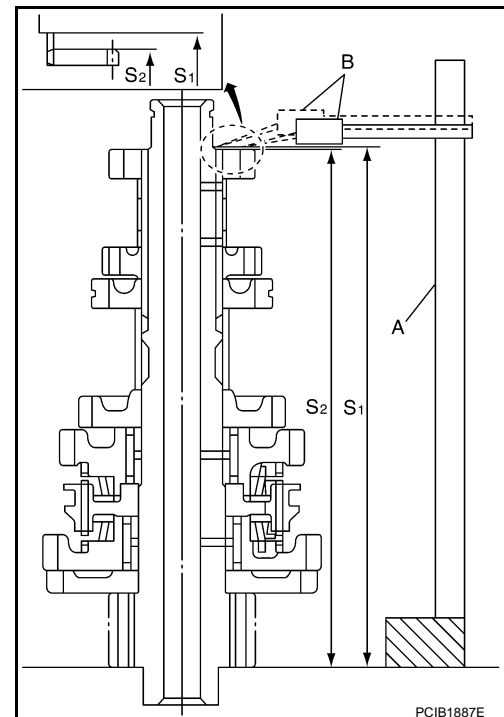

# MAINSHAFT AND GEARS

< SERVICE INFORMATION >

[RS6F52H]

17. Press in mainshaft rear bearing using Tools.

**Tool number**      **A: ST30720000 (J-25405)**  
                             **B: ST30901000 (J-26010-01)**

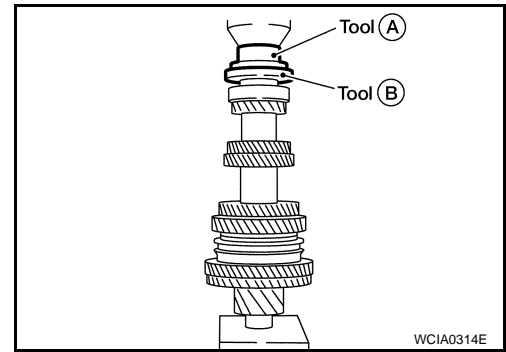

18. Install mainshaft C-rings onto mainshaft and check that end play of mainshaft rear bearing satisfies the standard value.

**End play standard value**  
: Refer to [MT-198, "Available C-Rings"](#).

- If measurement is outside the standard range, reselect mainshaft C-rings. Refer to [MT-198, "Available C-Rings"](#).

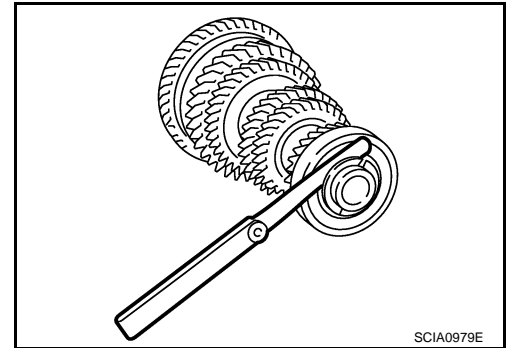

19. Install C-ring holder and then install snap ring.

**CAUTION:**  
**Do not reuse snap ring.**

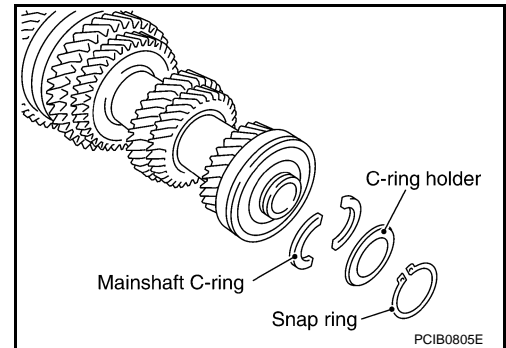

20. Check end play of 1st and 2nd main gears.

**End play standard value**  
: Refer to [MT-197, "Gear End Play"](#).

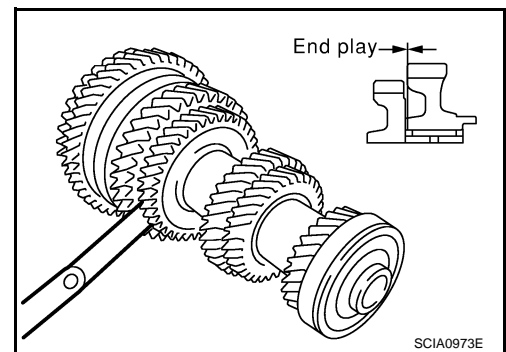

# REVERSE IDLER SHAFT AND GEARS

< SERVICE INFORMATION >

[RS6F52H]

## REVERSE IDLER SHAFT AND GEARS

### Disassembly and Assembly

INFOID:000000001850918

#### DISASSEMBLY

1. Remove reverse idler gear (rear), reverse coupling sleeve, and reverse insert springs simultaneously.
2. Remove reverse idler gear needle bearing.
3. Remove thrust needle bearing.
4. Remove reverse baulk ring.
5. Remove reverse idler gear (front).
6. Remove reverse idler gear needle bearing.
7. Remove thrust needle bearing.
8. Remove retaining pin from reverse idler shaft.

#### INSPECTION AFTER DISASSEMBLY

##### Reverse Idler Shaft and Gears

Check items below. If necessary, replace them with new ones.

- Damage, peeling, dent, uneven wear, bending, and other non-standard conditions of the shaft.
- Excessive wear, damage, peeling, and other non-standard conditions of the gears.

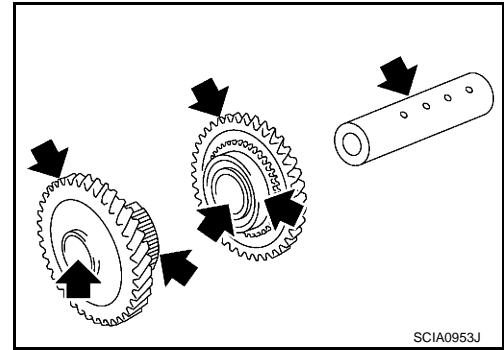

##### Synchronizer

Check items below. If necessary, replace them with new ones.

- Damage and unusual wear on contact surfaces of coupling sleeve, synchronizer hub of reverse idler gear (rear), and insert spring.
- Coupling sleeve and synchronizer hub of reverse idler gear (rear) must move smoothly.

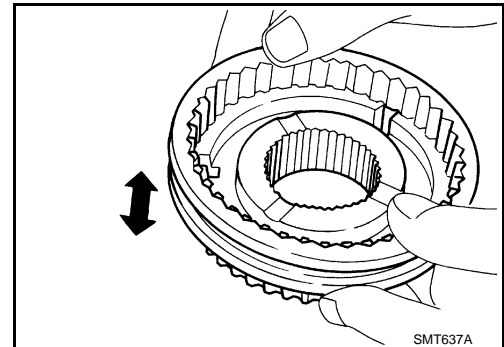

- If any crack, damage, or excessive wear is found on cam face of baulk ring or working face of insert, replace it.

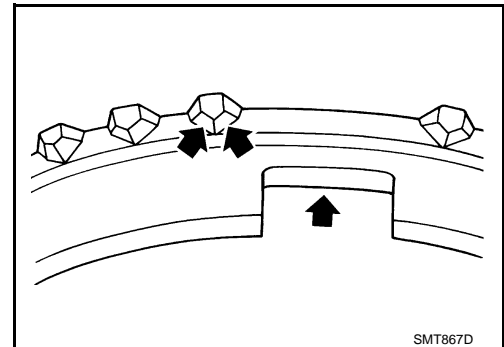

#### BAULK RING CLEARANCE

A  
B  
MT  
D  
E  
F  
G  
H  
I  
J  
K  
L  
M  
N  
O  
P

# REVERSE IDLER SHAFT AND GEARS

[RS6F52H]

## < SERVICE INFORMATION >

- Push baulk ring on the cone and measure the clearance between baulk ring and cone. If the measurement is below limit, replace it with a new one.

### Clearance

**Standard value** : Refer to [MT-197, "Baulk Ring Clearance"](#).

**Limit value** : Refer to [MT-197, "Baulk Ring Clearance"](#).

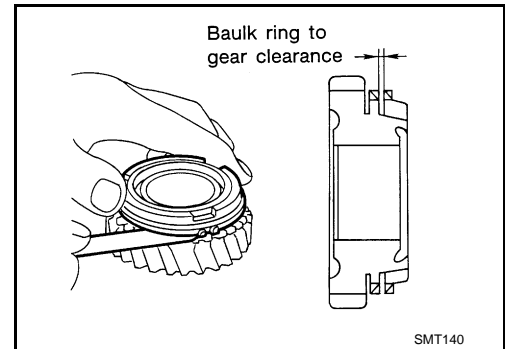

### Bearing

Check items below. If necessary, replace them with new ones.

- Damage and rough rotation of bearing.

## ASSEMBLY

Note the following, and assemble in the reverse order of disassembly.

### CAUTION:

- **Do not reuse retaining pin.**
- **Be careful with orientation of reverse insert spring.**

← : Front

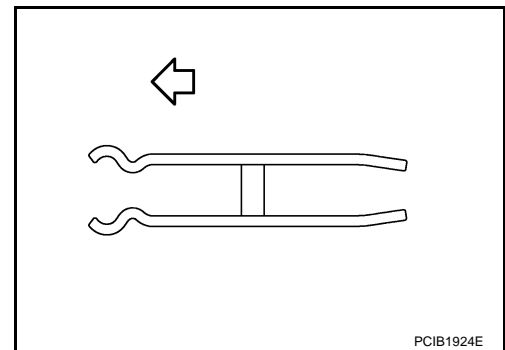

## FINAL DRIVE

### Disassembly and Assembly

INFOID:000000001850919

#### DISASSEMBLY

1. Remove final gear bolts and then separate the final gear from differential case.
2. Remove differential side bearing (clutch housing side) using Tool and pullers (B).

Tool number    A: ST33061000 (J-8107-2)

**CAUTION:**

**Hook a puller on the cage of differential side bearing.**

3. Remove speedometer drive gear.

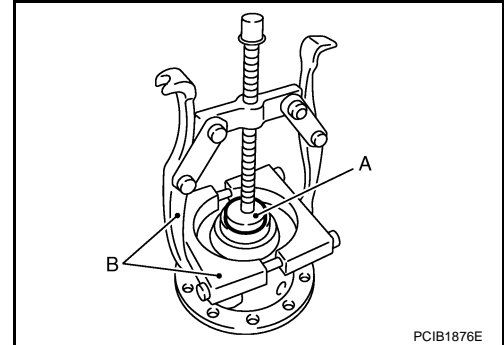

4. Remove differential side bearing (transaxle case side) using Tool and puller.

**CAUTION:**

**Hook a puller on the inner race of differential side bearing.**

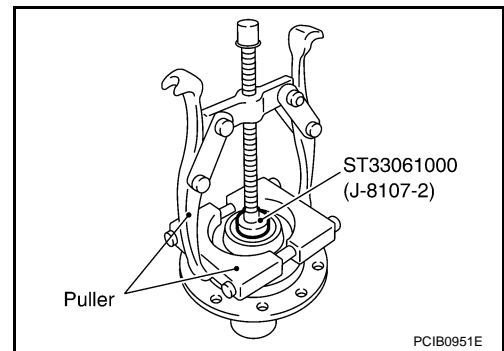

#### INSPECTION AFTER DISASSEMBLY

##### Bearing

- Check for bearings damage and rough rotation. If necessary, replace with a new one.

**CAUTION:**

**When replacing tapered roller bearing, replace outer and inner races as a set.**

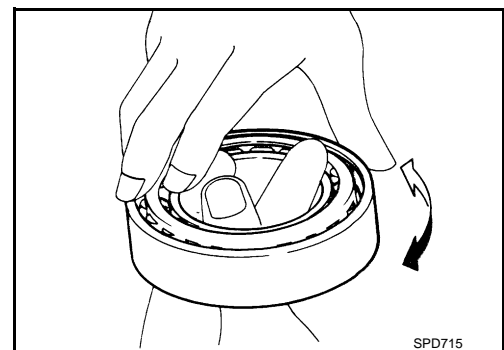

#### ASSEMBLY

1. Press in differential side bearing (transaxle case side) to differential case using Tools.

**CAUTION:**

**Replace differential side bearing and differential side bearing outer race as a set.**

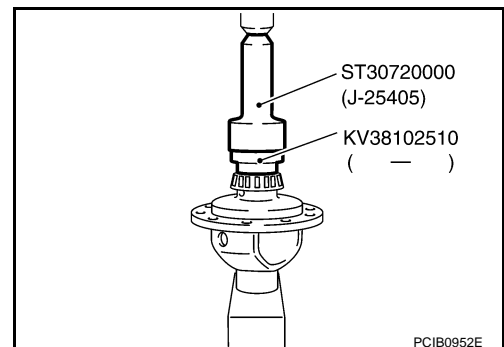

A  
B  
MT  
D  
E  
F  
G  
H  
I  
J  
K  
L  
M  
N  
O  
P

# FINAL DRIVE

[RS6F52H]

## < SERVICE INFORMATION >

- Align and install speedometer drive gear onto differential case.

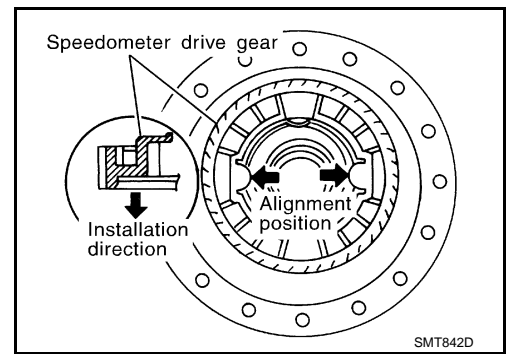

- Press in differential side bearing (clutch housing side) to differential case using Tools.

**Tool number**     **A: ST30720000 (J-25405)**

**B: KV38102510 ( — )**

### **CAUTION:**

- Do not reuse differential side bearing and differential side bearing outer race.
- Replace differential side bearing and differential side bearing outer race as a set.

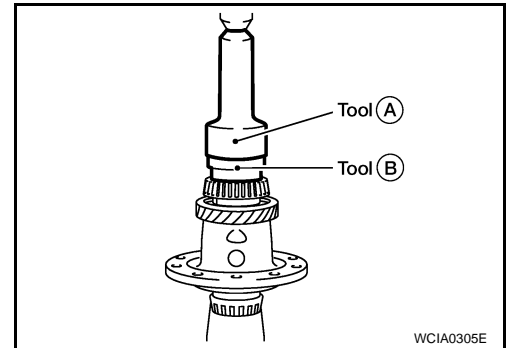

- Install final gear into differential case and tighten final gear bolts to the specified torque. Refer to [MT-144, "Disassembly and Assembly"](#).

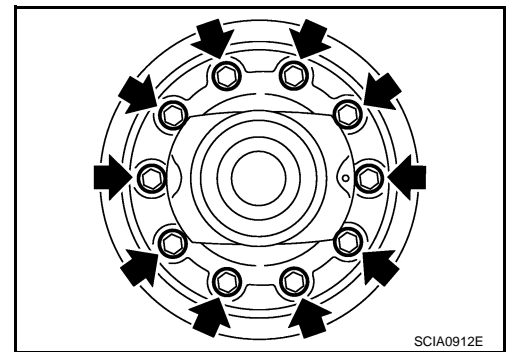



< SERVICE INFORMATION >

## SHIFT CONTROL

### Disassembly and Assembly

INFOID:000000001850920

#### DISASSEMBLY

1. Remove return spring to striking rod assembly.

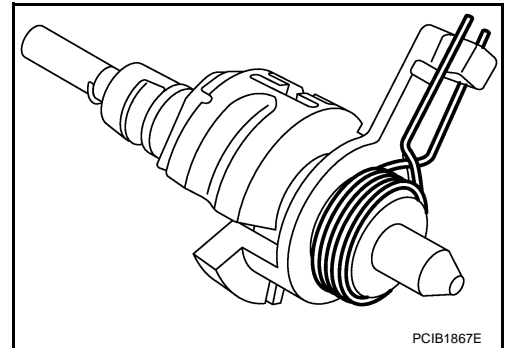

#### INSPECTION AFTER DISASSEMBLY

##### Striking Rod Assembly and Return Spring

- Check contact surfaces and sliding area for wear, damage, bending, etc. If necessary, replace parts.

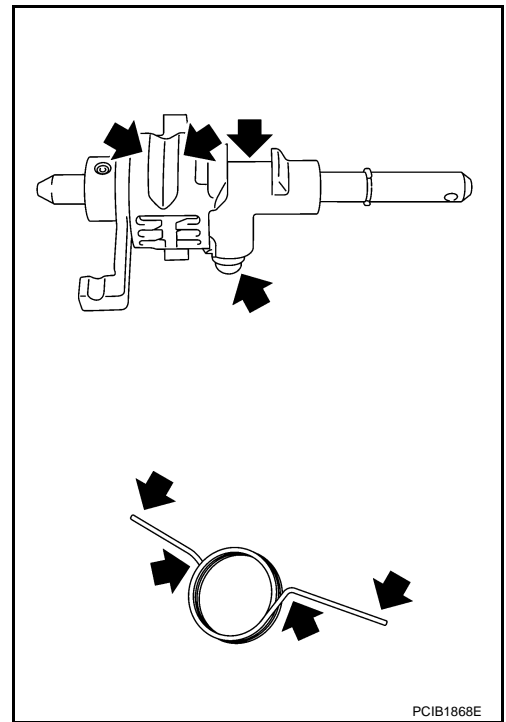

Fork Rod and Shift Fork

A  
B  
MT  
D  
E  
F  
G  
H  
I  
J  
K  
L  
M  
N  
O  
P

# SHIFT CONTROL

[RS6F52H]

## < SERVICE INFORMATION >

- Check contact surfaces and sliding area for wear, damage, bending, etc. If necessary, replace parts.

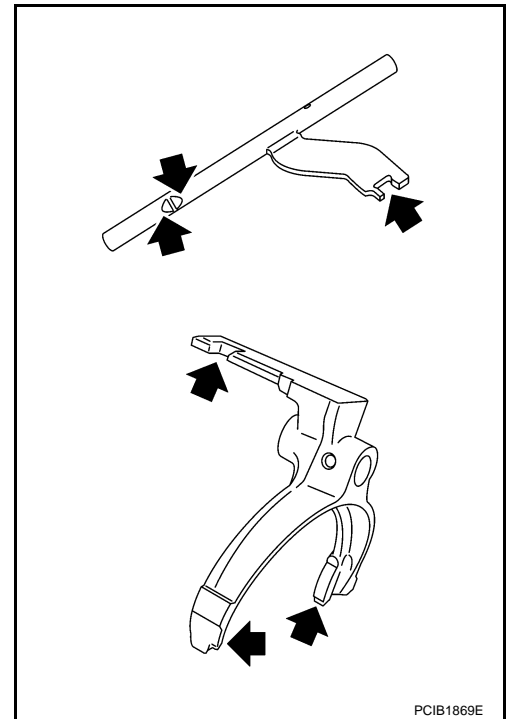

PCIB1869E

- Check if the width of shift fork hook (sliding area with coupling sleeve) is within allowable specification below.

Item	One-side wear specification	Sliding width of new part
1st-2nd	0.2 mm (0.008 in)	7.80 - 7.93 mm (0.3071 - 0.3122 in)
3rd-4th	0.2 mm (0.008 in)	7.80 - 7.93 mm (0.3071 - 0.3122 in)
5th-6th	0.2 mm (0.008 in)	6.10 - 6.23 mm (0.2402 - 0.2453 in)
Reverse	0.2 mm (0.008 in)	12.80 - 12.93 mm (0.5039 - 0.5091 in)

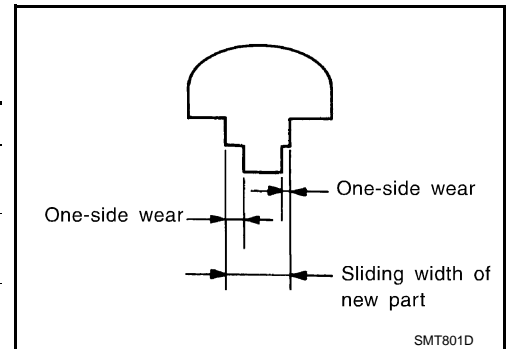

SMT801D

## ASSEMBLY

1. Temporarily install return spring to striking rod assembly.

**CAUTION:**

**Be careful with the orientation of return spring.**

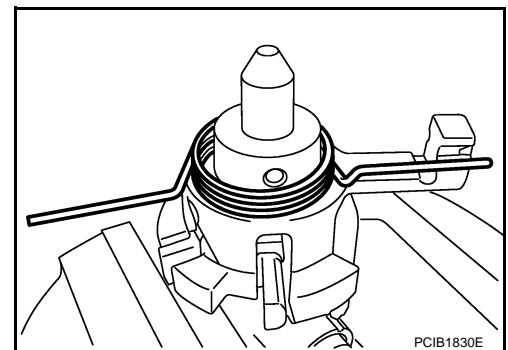

PCIB1830E

# SHIFT CONTROL

[RS6F52H]

## < SERVICE INFORMATION >

2. Attach one end of the return spring to striking interlock of striking rod assembly while holding return spring.

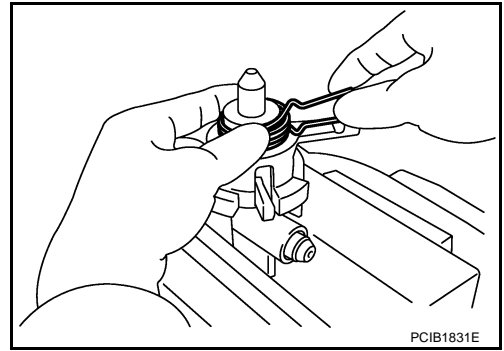

### CAUTION:

- When installing, check that return spring is securely seated in the groove of striking interlock of striking rod assembly.

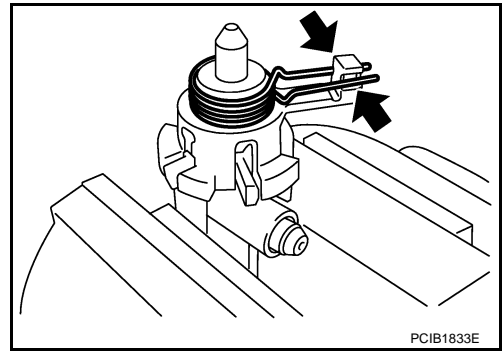

A  
B  
MT  
D  
E  
F  
G  
H  
I  
J  
K  
L  
M  
N  
O  
P

# SERVICE DATA AND SPECIFICATIONS (SDS)

< SERVICE INFORMATION >

[RS6F52H]

## SERVICE DATA AND SPECIFICATIONS (SDS)

### General Specification

INFOID:000000001850921

#### TRANSAXLE

Engine type		QR25DE	
Transaxle model		RS6F52H	
Model code number		ET85D	
Number of speed		6	
Synchromesh type		Warner	
Shift pattern		<p style="text-align: right; font-size: small;">PCIB1769E</p>	
Gear ratio	1st	3.153	
	2nd	1.950	
	3rd	1.392	
	4th	1.055	
	5th	0.809	
	6th	0.630	
	Reverse	3.002	
Number of teeth	Input gear	1st	13
		2nd	20
		3rd	28
		4th	36
		5th	42
		6th	46
		Reverse	13
	Main gear	1st	41
		2nd	39
		3rd	39
		4th	38
		5th	34
		6th	29
		Reverse	38
Reverse idler gear	Front	37	
	Rear	38	
Oil level	mm (in)	61.0 - 67.0 (2.402 - 2.638)	
Oil capacity (Reference)	ℓ (US pt, Imp pt)	1.7 (3-5/8, 3)	
Remarks	Reverse synchronizer	Installed	
	Double-cone synchronizer	3rd	
	Triple-cone synchronizer	1st and 2nd	

#### FINAL GEAR

# SERVICE DATA AND SPECIFICATIONS (SDS)

< SERVICE INFORMATION >

[RS6F52H]

Engine type	QR25DE	
Transaxle model	RS6F52H	
Model code number	ET85D	
Final gear ratio	4.428	
Number of teeth	Final gear/Pinion	62/14
	Side gear/Pinion mate gear	—

## Gear End Play

INFOID:000000001850922

Unit: mm (in)

Gear	Standard value
1st main gear	0.20 - 0.30 (0.0079 - 0.0118)
2nd main gear	0.06 - 0.16 (0.0024 - 0.0063)
3rd input gear	0.18 - 0.31 (0.0071 - 0.0122)
4th input gear	0.20 - 0.30 (0.0079 - 0.0118)
5th input gear	0.06 - 0.16 (0.0024 - 0.0063)
6th input gear	0.06 - 0.16 (0.0024 - 0.0063)

## Baulk Ring Clearance

INFOID:000000001850923

Unit: mm (in)

Measurement point	Standard value	Limit value	
3rd (Double-cone synchronizer)	Clearance between synchronizer cone and inner baulk ring end face "A"	0.6 - 0.8 (0.024 - 0.031)	0.2 (0.008)
	Clearance between outer baulk ring pawl and synchronizer cone "B"	0.6 - 1.1 (0.024 - 0.043)	0.2 (0.008)
1st and 2nd (Triple-cone synchronizer)	Clearance between synchronizer cone and clutch gear end face "A"	0.6 - 1.2 (0.024 - 0.047)	0.3 (0.012)
	Clearance between outer baulk ring pawl and synchronizer cone "B"	0.6 - 1.1 (0.024 - 0.043)	0.2 (0.008)
	Clearance between inner baulk ring and clutch gear end face "C"	0.7 - 1.1 (0.028 - 0.043)	0.3 (0.012)
4th		0.9 - 1.45 (0.035 - 0.057)	0.7 (0.028)
5th		0.95 - 1.4 (0.037 - 0.055)	0.7 (0.028)
6th		0.95 - 1.4 (0.037 - 0.055)	0.7 (0.028)
Reverse		0.95 - 1.4 (0.037 - 0.055)	0.7 (0.028)

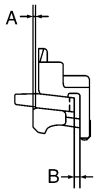

PCIB0249E

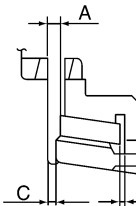

PCIB0835J

## Available Snap Rings

INFOID:000000001850924

## 6TH INPUT GEAR BUSHING

# SERVICE DATA AND SPECIFICATIONS (SDS)

< SERVICE INFORMATION >

[RS6F52H]

End play standard value		0 - 0.1 mm (0 - 0.004 in)	
Thickness mm (in)	Part number*	Thickness mm (in)	Part number*
1.76 (0.0693)	32204 8H511	2.01 (0.0791)	32204 8H516
1.81 (0.0713)	32204 8H512	2.06 (0.0811)	32204 8H517
1.86 (0.0732)	32204 8H513	2.11 (0.0831)	32204 8H518
1.91 (0.0752)	32204 8H514	2.16 (0.0850)	32204 8H519
1.96 (0.0772)	32204 8H515	2.21 (0.0870)	32204 8H520

\*: Always check with the Parts Department for the latest parts information.

## Available C-Rings

INFOID:000000001850925

### MAINSHAFT C-RING

End play standard value		0 - 0.06 mm (0 - 0.0024 in)	
Thickness mm (in)	Part number*	Thickness mm (in)	Part number*
2.535 (0.0998)	32348 8H800	2.835 (0.1116)	32348 8H810
2.565 (0.1010)	32348 8H801	2.865 (0.1128)	32348 8H811
2.595 (0.1022)	32348 8H802	2.895 (0.1140)	32348 8H812
2.625 (0.1033)	32348 8H803	2.925 (0.1152)	32348 8H813
2.655 (0.1045)	32348 8H804	2.955 (0.1163)	32348 8H814
2.685 (0.1057)	32348 8H805	2.985 (0.1175)	32348 8H815
2.715 (0.1069)	32348 8H806	3.015 (0.1187)	32348 8H816
2.745 (0.1081)	32348 8H807	3.045 (0.1199)	32348 8H817
2.775 (0.1093)	32348 8H808	3.075 (0.1211)	32348 8H818
2.805 (0.1104)	32348 8H809		

\*: Always check with the Parts Department for the latest parts information.

## Available Thrust Washer

INFOID:000000001850926

### INPUT SHAFT THRUST WASHER

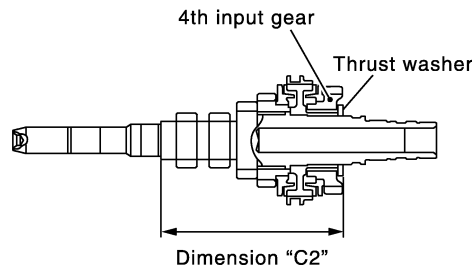

SCIA1008E

Standard value for dimension "C2"		154.7 - 154.8 mm (6.091 - 6.094 in)	
Thickness mm (in)	Part number*	Thickness mm (in)	Part number*
3.84 (0.1512)	32347 8H500	4.02 (0.1583)	32347 8H503
3.90 (0.1535)	32347 8H501	4.08 (0.1606)	32347 8H504
3.96 (0.1559)	32347 8H502	4.14 (0.1630)	32347 8H505

\*: Always check with the Parts Department for the latest parts information.

### DIFFERENTIAL SIDE GEAR THRUST WASHER

Allowable Clearance between side gear and differential case with thrust washer	0.1 - 0.2 mm (0.004 - 0.008 in)

# SERVICE DATA AND SPECIFICATIONS (SDS)

< SERVICE INFORMATION >

[RS6F52H]

Thickness mm (in)	Part number*
0.75 (0.0295)	38424 81X00
0.80 (0.0315)	38424 81X01
0.85 (0.0335)	38424 81X02
0.90 (0.0354)	38424 81X03
0.95 (0.0374)	38424 81X04

\*: Always check with the Parts Department for the latest parts information.

## Available Adjusting Shims

INFOID:000000001850927

### 4TH MAIN GEAR ADJUSTING SHIM

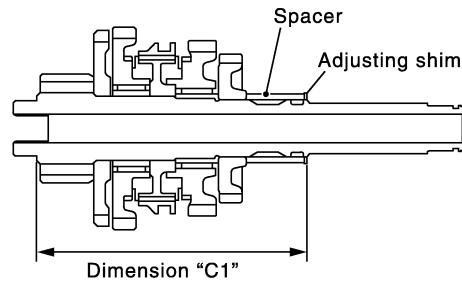

SCIA1009E

Standard value for dimension "C1"		173.85 - 173.95 mm (6.844 - 6.848 in)	
Thickness mm (in)	Part number*	Thickness mm (in)	Part number*
0.52 (0.0205)	32238 8H500	0.84 (0.0331)	32238 8H504
0.60 (0.0236)	32238 8H501	0.92 (0.0362)	32238 8H505
0.68 (0.0268)	32238 8H502	1.00 (0.0394)	32238 8H506
0.76 (0.0299)	32238 8H503	1.08 (0.0425)	32238 8H507

\*: Always check with the Parts Department for the latest parts information.

### INPUT SHAFT REAR BEARING ADJUSTING SHIM

End play standard value			0 - 0.06 mm (0 - 0.0024 in)		
Thickness mm (in)	Part number*	Thickness mm (in)	Part number*	Thickness mm (in)	Part number*
0.40 (0.0157)	32225 8H500	0.88 (0.0346)	32225 8H512	1.36 (0.0535)	32225 8H524
0.44 (0.0173)	32225 8H501	0.92 (0.0362)	32225 8H513	1.40 (0.0551)	32225 8H560
0.48 (0.0189)	32225 8H502	0.96 (0.0378)	32225 8H514	1.44 (0.0567)	32225 8H561
0.52 (0.0205)	32225 8H503	1.00 (0.0394)	32225 8H515	1.48 (0.0583)	32225 8H562
0.56 (0.0220)	32225 8H504	1.04 (0.0409)	32225 8H516	1.52 (0.0598)	32225 8H563
0.60 (0.0236)	32225 8H505	1.08 (0.0425)	32225 8H517	1.56 (0.0614)	32225 8H564
0.64 (0.0252)	32225 8H506	1.12 (0.0441)	32225 8H518	1.60 (0.0630)	32225 8H565
0.68 (0.0268)	32225 8H507	1.16 (0.0457)	32225 8H519	1.64 (0.0646)	32225 8H566
0.72 (0.0283)	32225 8H508	1.20 (0.0472)	32225 8H520		
0.76 (0.0299)	32225 8H509	1.24 (0.0488)	32225 8H521		
0.80 (0.0315)	32225 8H510	1.28 (0.0504)	32225 8H522		
0.84 (0.0331)	32225 8H511	1.32 (0.0520)	32225 8H523		

\*: Always check with the Parts Department for the latest parts information.

### MAINSHAFT REAR BEARING ADJUSTING SHIM

# SERVICE DATA AND SPECIFICATIONS (SDS)

< SERVICE INFORMATION >

[RS6F52H]

End play standard value		0 - 0.06 mm (0 - 0.0024 in)	
Thickness mm (in)	Part number*	Thickness mm (in)	Part number*
0.44 (0.0173)	32238 8H510	0.80 (0.0315)	32238 8H519
0.48 (0.0189)	32238 8H511	0.84 (0.0331)	32238 8H520
0.52 (0.0205)	32238 8H512	0.88 (0.0346)	32238 8H521
0.56 (0.0220)	32238 8H513	0.92 (0.0362)	32238 8H522
0.60 (0.0236)	32238 8H514	0.96 (0.0378)	32238 8H523
0.64 (0.0252)	32238 8H515	1.00 (0.0394)	32238 8H524
0.68 (0.0268)	32238 8H516	1.04 (0.0409)	32238 8H560
0.72 (0.0283)	32238 8H517	1.08 (0.0425)	32238 8H561
0.76 (0.0299)	32238 8H518		

\*: Always check with the Parts Department for the latest parts information.

## REVERSE IDLER GEAR ADJUSTING SHIM

End play standard value		0.04 - 0.10 mm (0.0016 - 0.0039 in)	
Thickness mm (in)	Part number*	Thickness mm (in)	Part number*
1.76 (0.0693)	32237 8H800	2.24 (0.0882)	32237 8H812
1.80 (0.0709)	32237 8H801	2.28 (0.0898)	32237 8H813
1.84 (0.0724)	32237 8H802	2.32 (0.0913)	32237 8H814
1.88 (0.0740)	32237 8H803	2.36 (0.0929)	32237 8H815
1.92 (0.0756)	32237 8H804	2.40 (0.0945)	32237 8H816
1.96 (0.0772)	32237 8H805	2.44 (0.0961)	32237 8H817
2.00 (0.0787)	32237 8H806	2.48 (0.0976)	32237 8H818
2.04 (0.0803)	32237 8H807	2.52 (0.0992)	32237 8H819
2.08 (0.0819)	32237 8H808	2.56 (0.1008)	32237 8H820
2.12 (0.0835)	32237 8H809	2.60 (0.1024)	32237 8H821
2.16 (0.0850)	32237 8H810	2.64 (0.1039)	32237 8H822
2.20 (0.0866)	32237 8H811		

\*: Always check with the Parts Department for the latest parts information.

## 6TH MAIN GEAR ADJUSTING SHIM

End play standard value		0 - 0.1 mm (0 - 0.004 in)	
Thickness mm (in)	Part number*	Thickness mm (in)	Part number*
0.88 (0.0346)	32237 8H560	1.20 (0.0472)	32237 8H564
0.96 (0.0378)	32237 8H561	1.28 (0.0504)	32237 8H565
1.04 (0.0409)	32237 8H562	1.36 (0.0535)	32237 8H566
1.12 (0.0441)	32237 8H563		

\*: Always check with the Parts Department for the latest parts information.

## STRIKING ROD ADJUSTING SHIM

End play standard value		0.05 - 0.152 mm (0.0020 - 0.0060 in)	
Thickness mm (in)	Part number*	Thickness mm (in)	Part number*
1.12 (0.0441)	33761 JA60A	1.52 (0.0598)	33761 JA65A
1.20 (0.0472)	33761 JA61A	1.60 (0.0630)	33761 JA66A
1.28 (0.0504)	33761 JA62A	1.68 (0.0661)	33761 JA67A
1.36 (0.0535)	33761 JA63A	1.76 (0.0693)	33761 JA68A
1.44 (0.0567)	33761 JA64A	1.84 (0.0724)	33761 JA69A

\*: Always check with the Parts Department for the latest parts information.

## Available Shims

INFOID:000000001850928

### — Differential Side Bearing Preload and Adjusting Shim

#### BEARING PRELOAD

Differential side bearing preload: L*	0.15 - 0.21 mm (0.0059 - 0.0083 in)
---------------------------------------	-------------------------------------



# SERVICE DATA AND SPECIFICATIONS (SDS)

[RS6F52H]

## < SERVICE INFORMATION >

\*: Install shims which are "deflection of differential case" + "L" in thickness.

### DIFFERENTIAL SIDE BEARING ADJUSTING SHIM(S)

Thickness mm (in)	Part number*	Thickness mm (in)	Part number*
0.48 (0.0189)	31438 80X00	0.72 (0.0283)	31438 80X06
0.52 (0.0205)	31438 80X01	0.76 (0.0299)	31438 80X07
0.56 (0.0220)	31438 80X02	0.80 (0.0315)	31438 80X08
0.60 (0.0236)	31438 80X03	0.84 (0.0331)	31438 80X09
0.64 (0.0252)	31438 80X04	0.88 (0.0346)	31438 80X10
0.68 (0.0268)	31438 80X05	0.92 (0.0362)	31438 80X11

\*: Always check with the Parts Department for the latest parts information.

A  
B  
MT  
D  
E  
F  
G  
H  
I  
J  
K  
L  
M  
N  
O  
P