

A
B
C
D
E
F
G
H
I
K
L
M

SECTION MTC

MANUAL AIR CONDITIONER

CONTENTS

PRECAUTIONS 4	System Construction 24
Precautions for Supplemental Restraint System (SRS) "AIR BAG" and "SEAT BELT PRE-TENSIONER" 4	OPERATION 24
Precautions for Working with HFC-134a (R-134a).... 4	TRANSMISSION DATA AND TRANSMISSION ORDER 25
Contaminated Refrigerant 4	AIR MIX DOOR CONTROL 25
General Refrigerant Precautions 5	BLOWER SPEED CONTROL 26
Precautions for Leak Detection Dye 5	INTAKE DOOR CONTROL 26
A/C Identification Label 5	MODE DOOR CONTROL 26
Precautions for Refrigerant Connection 5	MAGNET CLUTCH CONTROL 26
FEATURES OF NEW TYPE REFRIGERANT CONNECTION 6	Overview of Control system 26
O-RING AND REFRIGERANT CONNECTION 7	Control Operation 27
Precautions for Servicing Compressor 11	AIR CONDITIONER (A/C) SWITCH 28
Precautions for Service Equipment 11	TEMPERATURE DIAL (POTENTIO TEMPERATURE CONTROL) 28
RECOVERY/RECYCLING EQUIPMENT 11	BLOWER CONTROL DIAL/OFF SWITCH 28
ELECTRONIC LEAK DETECTOR 11	RECIRCULATION () SWITCH 28
VACUUM PUMP 12	DEFROSTER SWITCH 28
MANIFOLD GAUGE SET 12	MODE DIAL 28
SERVICE HOSES 12	REAR WINDOW DEFOGGER SWITCH 28
SERVICE COUPLERS 13	Discharge Air Flow 29
REFRIGERANT WEIGHT SCALE 13	System Description 30
CHARGING CYLINDER 13	SWITCHES AND THEIR CONTROL FUNCTION.. 30
PREPARATION 14	CAN Communication System Description 30
Special Service Tools 14	TROUBLE DIAGNOSIS 31
HFC-134a (R-134a) Service Tools and Equipment.. 14	How to Perform Trouble Diagnoses for Quick and Accurate Repair 31
Commercial Service Tools 17	WORK FLOW 31
REFRIGERATION SYSTEM 18	SYMPTOM TABLE 31
Refrigerant Cycle 18	Component Parts and Harness Connector Location.. 32
REFRIGERANT FLOW 18	ENGINE COMPARTMENT - QR25DE 32
Refrigerant System Protection 18	ENGINE COMPARTMENT - MR20DE 33
REFRIGERANT PRESSURE SENSOR 18	PASSENGER COMPARTMENT 34
PRESSURE RELIEF VALVE 18	Circuit Diagram 35
Component Layout 19	Wiring Diagram — HEATER — 36
OIL 21	Wiring Diagram — A/C,M — 38
Maintenance of Oil Quantity in Compressor 21	Front Air Control Terminals and Reference Values.. 41
OIL 21	INSPECTION OF FRONT AIR CONTROL 41
CHECKING AND ADJUSTING 21	FRONT AIR CONTROL HARNESS CONNECTOR TERMINAL LAYOUT 41
AIR CONDITIONER CONTROL 24	TERMINAL AND REFERENCE VALUES FOR
Overview Air Conditioner LAN Control System 24	

FRONT AIR CONTROL	41	IN-CABIN MICROFILTER	79
Operational Check	43	Removal and Installation	79
CHECKING BLOWER	43	FUNCTION	79
CHECKING DISCHARGE AIR	43	REPLACEMENT TIMING	79
CHECKING RECIRCULATION	43	REPLACEMENT PROCEDURES	79
CHECKING TEMPERATURE DECREASE	43	HEATER & COOLING UNIT ASSEMBLY	81
CHECKING TEMPERATURE INCREASE	43	Removal and Installation	81
CHECKING A/C SWITCH (IF EQUIPPED)	43	REMOVAL	81
Power Supply and Ground Circuit for Front Air Control	44	INSTALLATION	82
INSPECTION FLOW	44	HEATER CORE	83
COMPONENT DESCRIPTION	45	Removal and Installation	83
DIAGNOSTIC PROCEDURE	45	REMOVAL	83
LAN System Circuit	47	INSTALLATION	83
DIAGNOSTIC PROCEDURE	47	INTAKE DOOR MOTOR	84
Mode Door Motor Circuit	50	Removal and Installation	84
INSPECTION FLOW	50	REMOVAL	84
SYSTEM DESCRIPTION	51	INSTALLATION	84
COMPONENT DESCRIPTION	51	MODE DOOR MOTOR	85
DIAGNOSTIC PROCEDURE	51	Removal and Installation	85
Air Mix Door Motor Circuit	52	REMOVAL	85
INSPECTION FLOW	52	INSTALLATION	85
SYSTEM DESCRIPTION	53	AIR MIX DOOR MOTOR	86
COMPONENT DESCRIPTION	53	Removal and Installation	86
DIAGNOSTIC PROCEDURE	53	REMOVAL	86
Intake Door Motor Circuit	54	INSTALLATION	86
INSPECTION FLOW	54	FAN CONTROL AMPLIFIER	87
SYSTEM DESCRIPTION	55	Removal and Installation	87
COMPONENT DESCRIPTION	55	REMOVAL	87
DIAGNOSTIC PROCEDURE	55	INSTALLATION	87
Blower Motor Circuit	56	DUCTS AND GRILLES	88
INSPECTION FLOW	56	Removal and Installation	88
SYSTEM DESCRIPTION	57	CENTER VENTILATOR GRILLE RH, LH	89
COMPONENT DESCRIPTION	57	UPPER DEFROSTER GRILLE	89
DIAGNOSTIC PROCEDURE	58	SIDE VENTILATOR GRILLE RH, LH	90
COMPONENT INSPECTION	61	SIDE DEFROSTER GRILLE RH, LH	90
Magnet Clutch Circuit	62	SIDE VENTILATOR DUCT RH, LH	90
INSPECTION FLOW	62	DEFROSTER NOZZLE	90
SYSTEM DESCRIPTION	63	SIDE DEFROSTER DUCT RH, LH	90
DIAGNOSTIC PROCEDURE	63	FRONT FOOT DUCT RH	90
Insufficient Cooling	66	FRONT FOOT DUCT LH	90
INSPECTION FLOW	66	REAR FLOOR CONNECTOR DUCT	90
PERFORMANCE TEST ANALYSIS	68	REAR FLOOR DUCT RH	91
PERFORMANCE CHART	70	REAR FLOOR DUCT LH	91
TROUBLE DIAGNOSIS FOR ABNORMAL PRESSURE	70	REFRIGERANT LINES	92
Insufficient Heating	74	HFC-134a (R-134a) Service Procedure	92
INSPECTION FLOW	74	SETTING OF SERVICE TOOLS AND EQUIPMENT	92
Noise	76	Components	94
INSPECTION FLOW	76	Removal and Installation for Compressor - MR20DE	97
CONTROL UNIT	77	REMOVAL	97
Removal and Installation	77	INSTALLATION	97
FRONT AIR CONTROL	77	Removal and Installation for Compressor — QR25DE	98
FRONT BLOWER MOTOR	78	REMOVAL	98
Removal and Installation	78	INSTALLATION	98
REMOVAL	78	Removal and Installation for Compressor Clutch - MR20DE	99
INSTALLATION	78	REMOVAL	99

INSPECTION AFTER REMOVAL	100	INSTALLATION	105	
INSTALLATION	100	Removal and Installation for Condenser	105	A
INSPECTION AFTER INSTALLATION	101	REMOVAL	105	
BREAK-IN OPERATION	101	INSTALLATION	106	
Removal and Installation for Compressor Clutch -		Removal and Installation for Evaporator	106	B
QR25DE	101	REMOVAL	106	
REMOVAL	101	INSTALLATION	107	
INSPECTION AFTER REMOVAL	102	Removal and Installation for Expansion Valve	107	C
INSTALLATION	103	REMOVAL	107	
INSPECTION AFTER INSTALLATION	104	INSTALLATION	107	
BREAK-IN OPERATION	104	Checking for Refrigerant Leaks	107	
Removal and Installation for Low-pressure Flexible		Checking System for Leaks Using the Fluorescent		D
Hose and Muffler Pipe	104	Leak Detector	108	
REMOVAL	104	Dye Injection	108	
INSTALLATION	104	Electronic Refrigerant Leak Detector	108	E
Removal and Installation for High-pressure Flexible		PRECAUTIONS FOR HANDLING THE LEAK		
Hose	104	DETECTOR	108	
REMOVAL	104	CHECKING PROCEDURE	109	F
INSTALLATION	105	SERVICE DATA AND SPECIFICATIONS (SDS)	111	
Removal and Installation for High-pressure Pipe ..	105	Service Data and Specifications (SDS)	111	
REMOVAL	105	COMPRESSOR	111	G
INSTALLATION	105	OIL	111	
Removal and Installation for Refrigerant Pressure		REFRIGERANT	111	
Sensor	105	ENGINE IDLING SPEED	111	H
REMOVAL	105	BELT TENSION	111	

MTC

K

L

M

PRECAUTIONS

PRECAUTIONS

PF0:00001

Precautions for Supplemental Restraint System (SRS) “AIR BAG” and “SEAT BELT PRE-TENSIONER”

EJS00504

The Supplemental Restraint System such as “AIR BAG” and “SEAT BELT PRE-TENSIONER”, used along with a front seat belt, helps to reduce the risk or severity of injury to the driver and front passenger for certain types of collision. This system includes seat belt switch inputs and dual stage front air bag modules. The SRS system uses the seat belt switches to determine the front air bag deployment, and may only deploy one front air bag, depending on the severity of a collision and whether the front occupants are belted or unbelted. Information necessary to service the system safely is included in the SRS and SB section of this Service Manual.

WARNING:

- To avoid rendering the SRS inoperative, which could increase the risk of personal injury or death in the event of a collision which would result in air bag inflation, all maintenance must be performed by an authorized NISSAN/INFINITI dealer.
- Improper maintenance, including incorrect removal and installation of the SRS, can lead to personal injury caused by unintentional activation of the system. For removal of Spiral Cable and Air Bag Module, see the SRS section.
- Do not use electrical test equipment on any circuit related to the SRS unless instructed to in this Service Manual. SRS wiring harnesses can be identified by yellow and/or orange harnesses or harness connectors.

Precautions for Working with HFC-134a (R-134a)

EJS00505

WARNING:

- CFC-12 (R-12) refrigerant and HFC-134a (R-134a) refrigerant are not compatible. If the refrigerants are mixed compressor failure is likely to occur. Refer to [MTC-4, "Contaminated Refrigerant"](#) . To determine the purity of HFC-134a (R-134a) in the vehicle and recovery tank, use Refrigerant Recovery/Recycling Recharging equipment and Refrigerant Identifier.
- Use only specified oil for the HFC-134a (R-134a) A/C system and HFC-134a (R-134a) components. If oil other than that specified is used, compressor failure is likely to occur.
- The specified HFC-134a (R-134a) oil rapidly absorbs moisture from the atmosphere. The following handling precautions must be observed:
 - When removing refrigerant components from a vehicle, immediately cap (seal) the component to minimize the entry of moisture from the atmosphere.
 - When installing refrigerant components to a vehicle, do not remove the caps (unseal) until just before connecting the components. Connect all refrigerant loop components as quickly as possible to minimize the entry of moisture into system.
 - Only use the specified oil from a sealed container. Immediately reseal containers of oil. Without proper sealing, oil will become moisture saturated and should not be used.
 - Avoid breathing A/C refrigerant and oil vapor or mist. Exposure may irritate eyes, nose and throat. Remove HFC-134a (R-134a) from the A/C system using certified service equipment meeting requirements of SAE J2210 [HFC-134a (R-134a) recycling equipment], or J2209 [HFC-134a (R-134a) recycling equipment], If accidental system discharge occurs, ventilate work area before resuming service. Additional health and safety information may be obtained from refrigerant and oil manufacturers.
 - Do not allow A/C oil to come in contact with styrofoam parts. Damage may result.

Contaminated Refrigerant

EJS00506

If a refrigerant other than pure HFC-134a (R-134a) is identified in a vehicle, your options are:

- Explain to the customer that environmental regulations prohibit the release of contaminated refrigerant into the atmosphere.
- Explain that recovery of the contaminated refrigerant could damage your service equipment and refrigerant supply.
- Suggest the customer return the vehicle to the location of previous service where the contamination may have occurred.
- If you choose to perform the repair, recover the refrigerant using only **dedicated equipment and containers**. **Do not recover contaminated refrigerant into your existing service equipment**. If your facility

PRECAUTIONS

does not have dedicated recovery equipment, you may contact a local refrigerant product retailer for available service. This refrigerant must be disposed of in accordance with all federal and local regulations. In addition, replacement of all refrigerant system components on the vehicle is recommended.

- If the vehicle is within the warranty period, the air conditioner warranty is void. Please contact NISSAN Customer Affairs for further assistance.

General Refrigerant Precautions

EJS00507

WARNING:

- Do not release refrigerant into the air. Use approved recovery/recycling equipment to capture the refrigerant every time an air conditioning system is discharged.
- Always wear eye and hand protection (goggles and gloves) when working with any refrigerant or air conditioning system.
- Do not store or heat refrigerant containers above 52°C (125°F).
- Do not heat a refrigerant container with an open flame; if container warming is required, place the bottom of the container in a warm pail of water.
- Do not intentionally drop, puncture, or incinerate refrigerant containers.
- Keep refrigerant away from open flames: poisonous gas will be produced if refrigerant burns.
- Refrigerant will displace oxygen, therefore be certain to work in well ventilated areas to prevent suffocation.
- Do not pressure test or leak test HFC-134a (R-134a) service equipment and/or vehicle air conditioning systems with compressed air during repair. Some mixtures of air and HFC-134a (R-134a) have been shown to be combustible at elevated pressures. These mixtures, if ignited, may cause injury or property damage. Additional health and safety information may be obtained from refrigerant manufacturers.

Precautions for Leak Detection Dye

EJS00508

- The A/C system contains a fluorescent leak detection dye used for locating refrigerant leaks. An ultraviolet (UV) lamp is required to illuminate the dye when inspecting for leaks.
- Always wear fluorescence enhancing UV safety goggles to protect your eyes and enhance the visibility of the fluorescent dye.
- A compressor shaft seal should not be repaired because of dye seepage. The compressor shaft seal should only be repaired after confirming the leak with an electronic refrigerant leak detector (J-41995).
- Always remove any dye from the leak area after repairs are complete to avoid a misdiagnosis during a future service.
- Do not allow dye to come into contact with painted body panels or interior components. If dye is spilled, clean immediately with the approved dye cleaner. Fluorescent dye left on a surface for an extended period of time **cannot be removed**.
- Do not spray the fluorescent dye cleaning agent on hot surfaces (engine exhaust manifold, etc.).
- Do not use more than one refrigerant dye bottle (1/4 ounce / 7.4 cc) per A/C system.
- Leak detection dyes for HFC-134a (R-134a) and CFC-12 (R-12) A/C systems are different. Do not use HFC-134a (R-134a) leak detection dye in CFC-12 (R-12) A/C systems or CFC-12 (R-12) leak detection dye in HFC-134a (R-134a) A/C systems or A/C system damage may result.
- The fluorescent properties of the dye will remain for over three (3) years unless a compressor failure occurs.

A/C Identification Label

EJS00509

Vehicles with factory installed fluorescent dye have this green identification label on the underside of hood.

Precautions for Refrigerant Connection

EJS0050A

A new type refrigerant connection has been introduced to all refrigerant lines except the following locations.

- Expansion valve to cooling unit
- Evaporator pipes to evaporator (inside cooling unit)
- Refrigerant pressure sensor

PRECAUTIONS

FEATURES OF NEW TYPE REFRIGERANT CONNECTION

- The O-ring has been relocated. It has also been provided with a groove for proper installation. This eliminates the chance of the O-ring being caught in, or damaged by, the mating part. The sealing direction of the O-ring is now set vertically in relation to the contacting surface of the mating part to improve sealing characteristics.
- The reaction force of the O-ring will not occur in the direction that causes the joint to pull out, thereby facilitating piping connections.

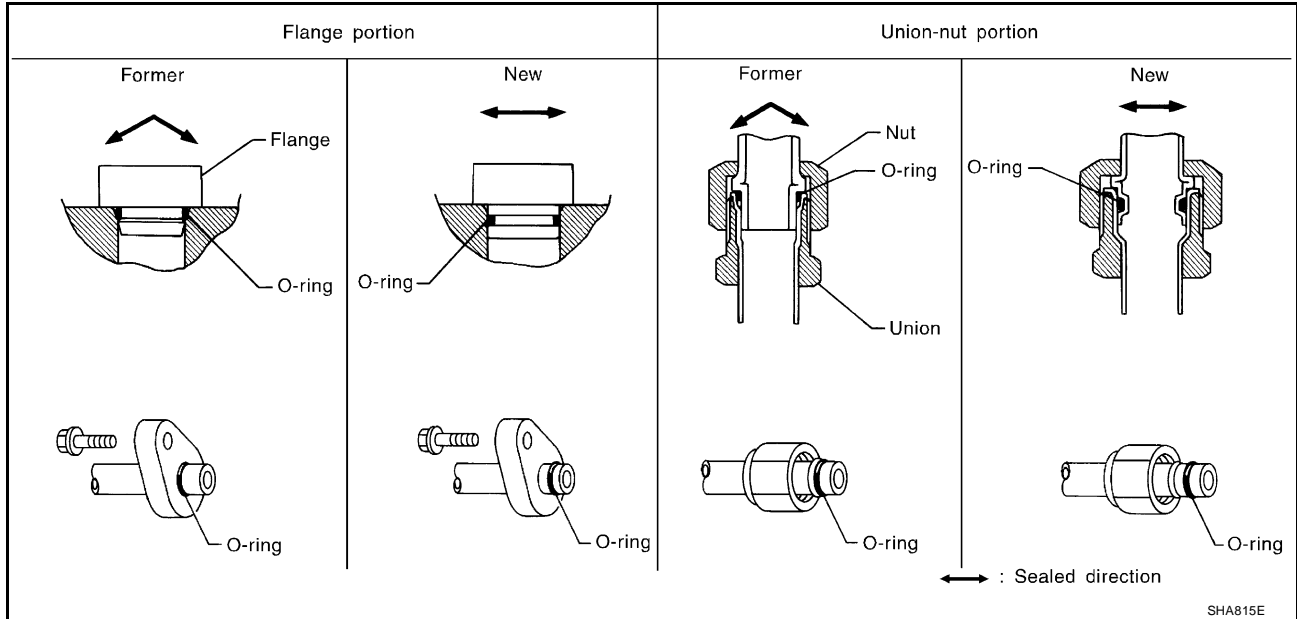

PRECAUTIONS

O-RING AND REFRIGERANT CONNECTION

MR20DE

SEC. 214 • 271 • 274 • 276

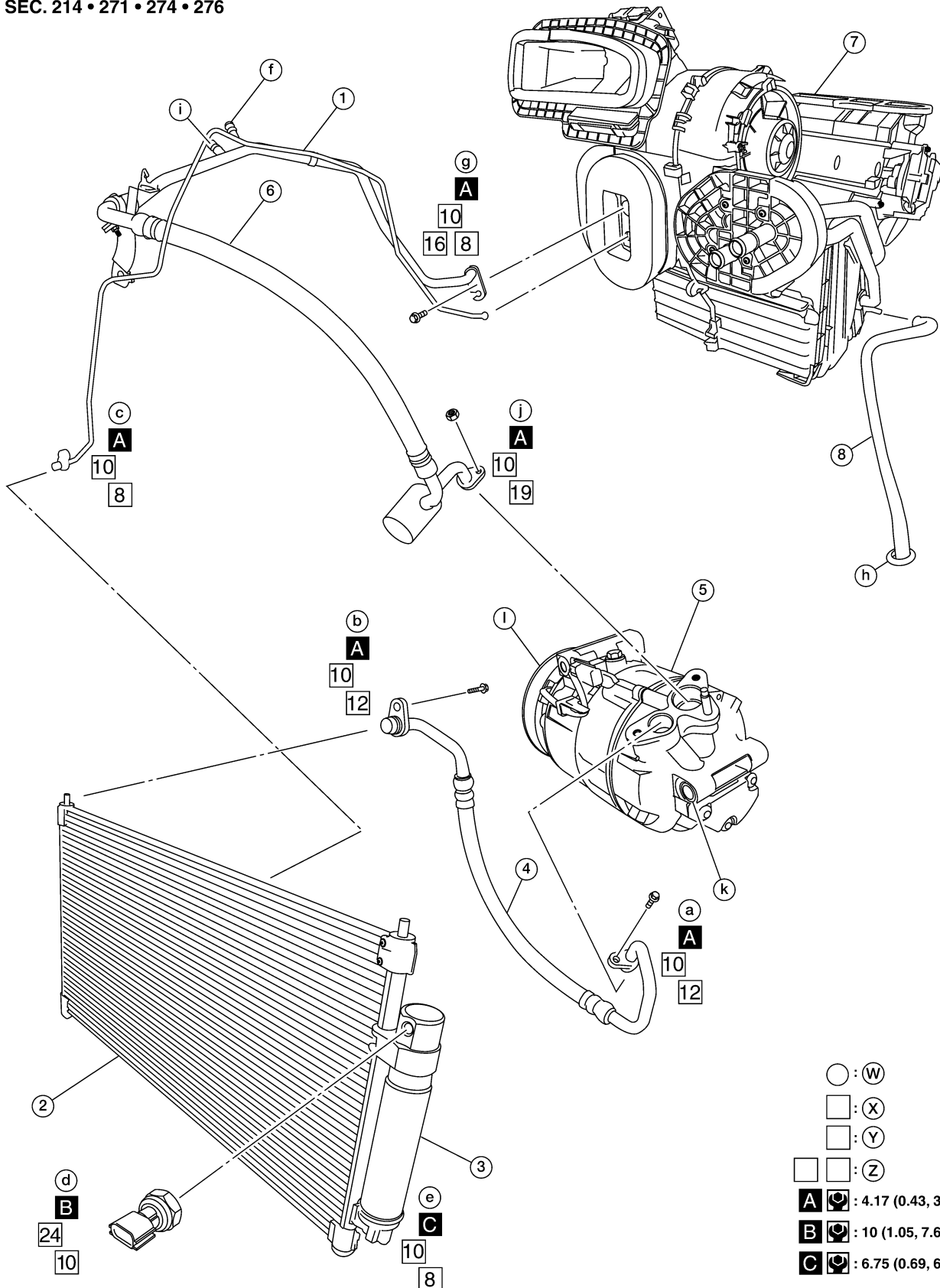

- : (W)
- : (X)
- : (Y)
- : (Z)
- A** : 4.17 (0.43, 37)
- B** : 10 (1.05, 7.6)
- C** : 6.75 (0.69, 60)

A
B
C
D
E
F
G
H
I
K
L
M

MTC

PRECAUTIONS

- | | | |
|-------------------------------------|----------------|------------------------------------|
| 1. High-pressure pipe | 2. Condenser | 3. Liquid tank |
| 4. High-pressure flexible hose | 5. Compressor | 6. Low-pressure flexible hose |
| 7. Heater and cooling unit assembly | 8. Drain hose | W. Refrigerant leak checking order |
| X. Tightening torque (A-C) | Y. Wrench size | Z. O-ring size |

PRECAUTIONS

QR25DE

SEC. 214 • 271 • 274 • 276

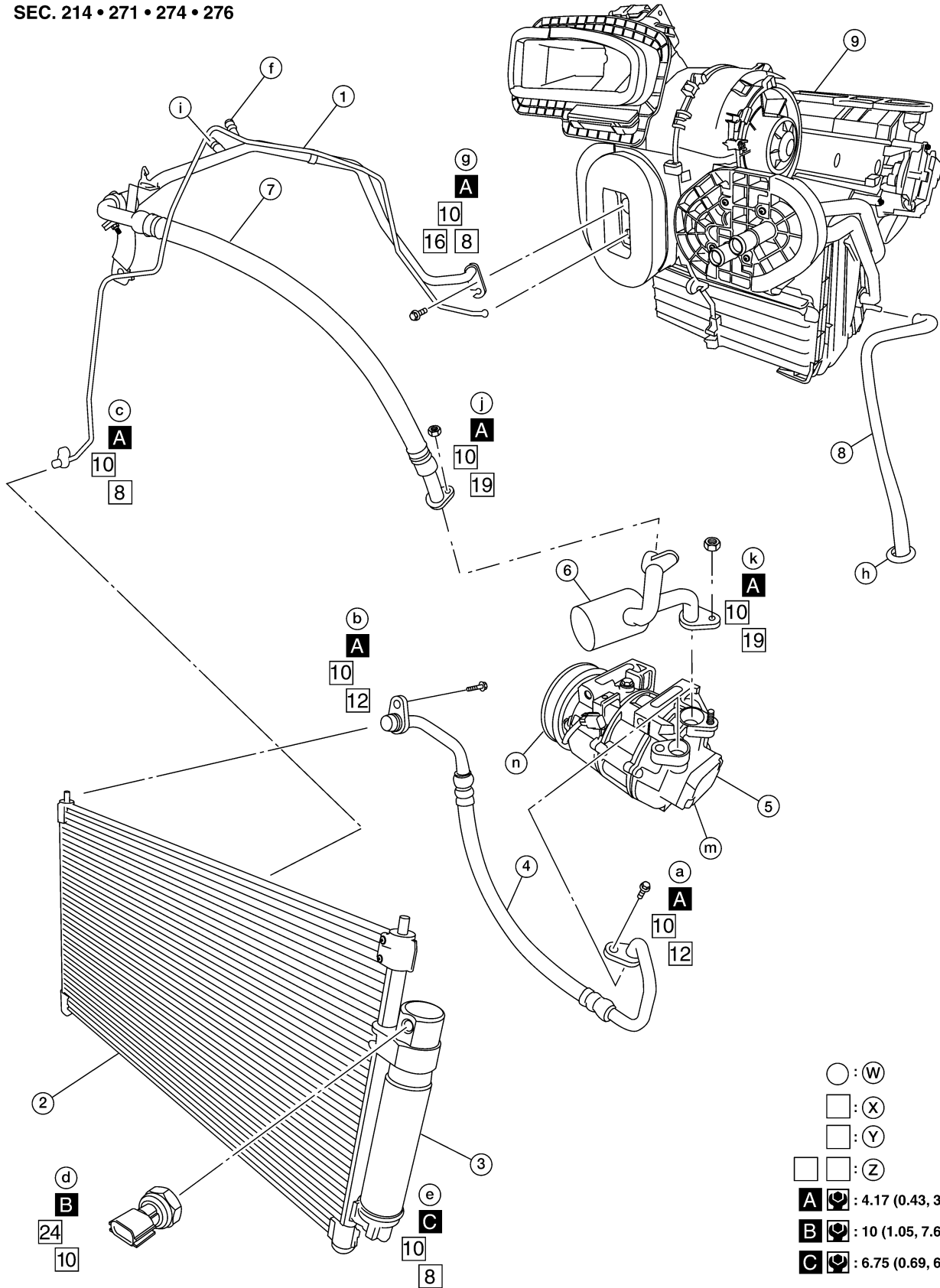

- | | | |
|--------------------------------|---------------|-----------------|
| 1. High-pressure pipe | 2. Condenser | 3. Liquid tank |
| 4. High-pressure flexible hose | 5. Compressor | 6. Muffler pipe |

- : (W)
 □ : (X)
 □ : (Y)
 □ : (Z)
A : 4.17 (0.43, 37)
B : 10 (1.05, 7.6)
C : 6.75 (0.69, 60)

WJIA2304E

PRECAUTIONS

- | | | |
|------------------------------------|----------------------------|-------------------------------------|
| 7. Low-pressure flexible hose | 8. Drain hose | 9. Heater and cooling unit assembly |
| W. Refrigerant leak checking order | X. Tightening torque (A-C) | Y. Wrench size |
| Z. O-ring size | | |

CAUTION:

The new and former refrigerant connections use different O-ring configurations. Do not confuse O-rings since they are not interchangeable. If a wrong O-ring is installed, refrigerant will leak at, or around, the connection.

O-Ring Part Numbers and Specifications

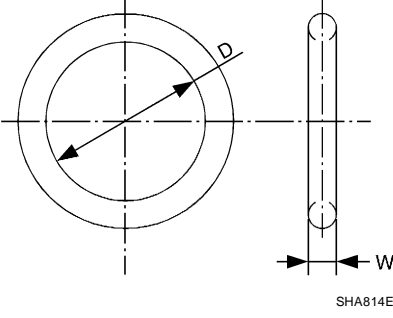
	Conne- ction type	O-ring size	Part number*	D mm (in)	W mm (in)
	New	8	92471 N8210	6.8 (0.268)	1.85 (0.0728)
Former	10	J2476 89956	9.25 (0.3642)	1.78 (0.0701)	
New	12	92472 N8210	10.9 (0.429)	2.43 (0.0957)	
Former		92475 71L00	11.0 (0.433)	2.4 (0.094)	
New	16	92473 N8210	13.6 (0.535)	2.43 (0.0957)	
Former		92475 72L00	14.3 (0.563)	2.3 (0.091)	
New	19	92474 N8210	16.5 (0.650)	2.43 (0.0957)	
Former		92477 N8200	17.12 (0.6740)	1.78 (0.0701)	
New	24	92195 AH300	21.8 (0.858)	2.4 (0.094)	

*: Always check with the Parts Department for the latest parts information.

WARNING:

Make sure all refrigerant is discharged into the recycling equipment and the pressure in the system is less than atmospheric pressure. Then gradually loosen the discharge side hose fitting and remove it.

CAUTION:

When replacing or cleaning refrigerant cycle components, observe the following.

- When the compressor is removed, store it in the same position as it is when mounted on the car. Failure to do so will cause oil to enter the low pressure chamber.
- When connecting tubes, always use a torque wrench and a back-up wrench.
- After disconnecting tubes, immediately plug all openings to prevent entry of dirt and moisture.
- When installing an air conditioner in the vehicle, connect the pipes as the final stage of the operation. Do not remove the seal caps of pipes and other components until just before required for connection.
- Allow components stored in cool areas to warm to working area temperature before removing seal caps. This prevents condensation from forming inside A/C components.
- Thoroughly remove moisture from the refrigeration system before charging the refrigerant.
- Always replace used O-rings.
- When connecting tube, apply oil to circle of the O-rings shown in illustration. Be careful not to apply oil to threaded portion.
Oil name: NISSAN A/C System Oil Type S or equivalent
- O-ring must be closely attached to grooved portion of tube.
- When replacing the O-ring, be careful not to damage O-ring and tube.
- Connect tube until you hear it click, then tighten the nut or bolt by hand until snug. Make sure that the O-ring is installed to tube correctly.

PRECAUTIONS

- After connecting line, conduct leak test and make sure that there is no leakage from connections. When the gas leaking point is found, disconnect that line and replace the O-ring. Then tighten connections of seal seat to the specified torque.

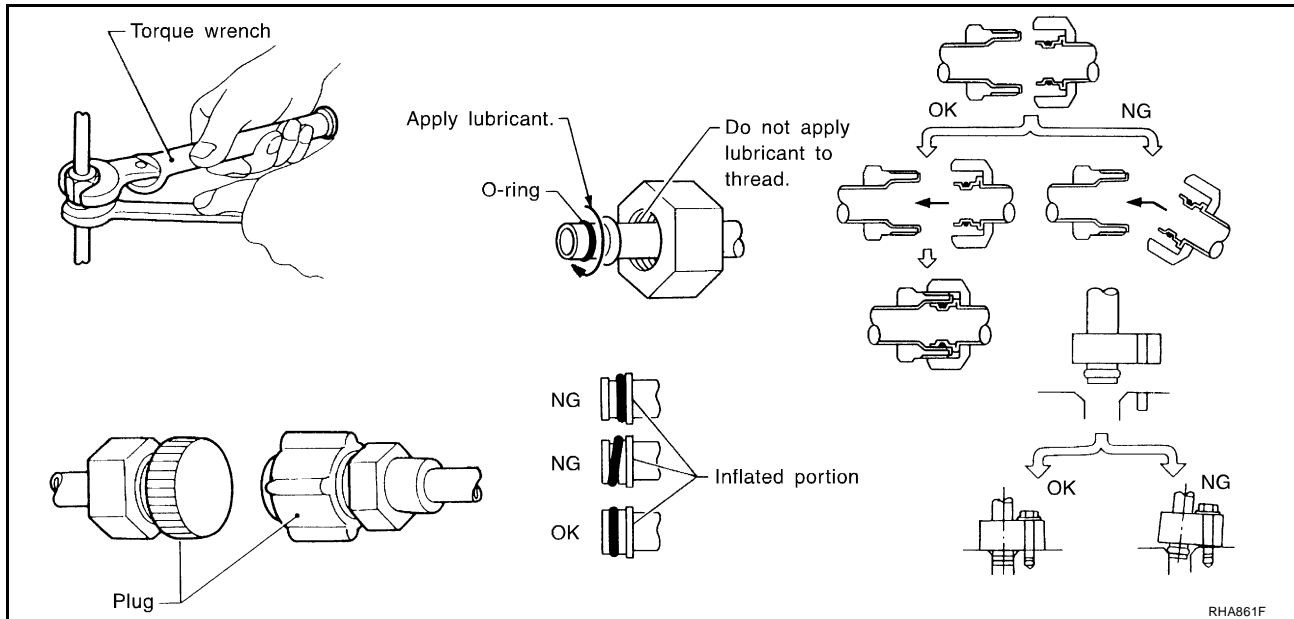

Precautions for Servicing Compressor

EJS0050B

- Plug all openings to prevent moisture and foreign matter from entering.
- When the compressor is removed, store it in the same position as it is when mounted on the car.
- When replacing or repairing compressor, follow "Maintenance of Oil Quantity in Compressor" exactly. Refer to [MTC-21, "Maintenance of Oil Quantity in Compressor"](#).
- Keep friction surfaces between clutch and pulley clean. If the surface is contaminated, with oil, wipe it off by using a clean waste cloth moistened with thinner.
- After compressor service operation, turn the compressor shaft by hand more than 5 turns in both directions. This will equally distribute oil inside the compressor. After the compressor is installed, let the engine idle and operate the compressor for 1 hour.
- After replacing the compressor magnet clutch, apply voltage to the new one and check for normal operation. [Gap between clutch disc and pulley is 0.3 - 0.6 mm (0.012 - 0.024 in)]

Precautions for Service Equipment RECOVERY/RECYCLING EQUIPMENT

EJS0050C

Follow the manufacturer's instructions for machine operation and machine maintenance. Never introduce any refrigerant other than that specified into the machine.

ELECTRONIC LEAK DETECTOR

Follow the manufacturer's instructions for tester operation and tester maintenance.

PRECAUTIONS

VACUUM PUMP

The oil contained inside the vacuum pump is not compatible with the specified oil for HFC-134a (R-134a) A/C systems. The vent side of the vacuum pump is exposed to atmospheric pressure so the vacuum pump oil may migrate out of the pump into the service hose. This is possible when the pump is switched off after evacuation (vacuuming) and hose is connected to it.

To prevent this migration, use a manual valve situated near the hose-to-pump connection, as follows.

- Usually vacuum pumps have a manual isolator valve as part of the pump. Close this valve to isolate the service hose from the pump.
- For pumps without an isolator, use a hose equipped with a manual shut-off valve near the pump end. Close the valve to isolate the hose from the pump.
- If the hose has an automatic shut off valve, disconnect the hose from the pump: as long as the hose is connected, the valve is open and lubricating oil may migrate.

Some one-way valves open when vacuum is applied and close under a no vacuum condition. Such valves may restrict the pump's ability to pull a deep vacuum and are not recommended.

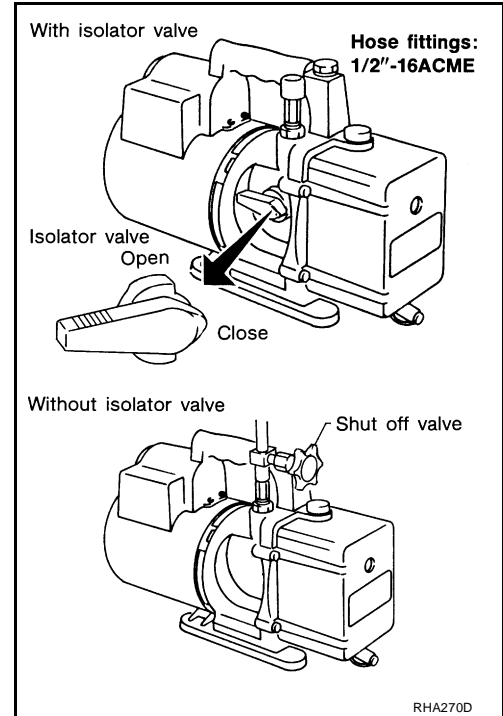

MANIFOLD GAUGE SET

Be certain that the gauge face indicates R-134a or 134a. Make sure the gauge set has 1/2"-16 ACME threaded connections for service hoses. Confirm the set has been used only with refrigerant HFC-134a (R-134a) along with specified oil.

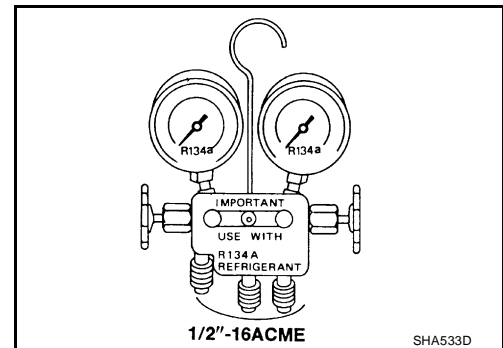

SERVICE HOSES

Be certain that the service hoses display the markings described (colored hose with black stripe). All hoses must include positive shut-off devices (either manual or automatic) near the end of the hoses opposite the manifold gauge.

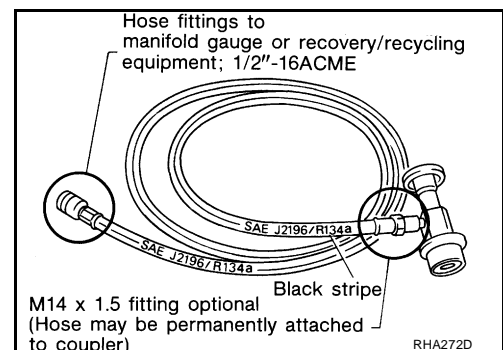

PRECAUTIONS

SERVICE COUPLERS

Never attempt to connect HFC-134a (R-134a) service couplers to a CFC-12 (R-12) A/C system. The HFC-134a (R-134a) couplers will not properly connect to the CFC-12 (R-12) system. However, if an improper connection is attempted, discharging and contamination may occur.

Shut-off valve rotation	A/C service valve
Clockwise	Open
Counterclockwise	Close

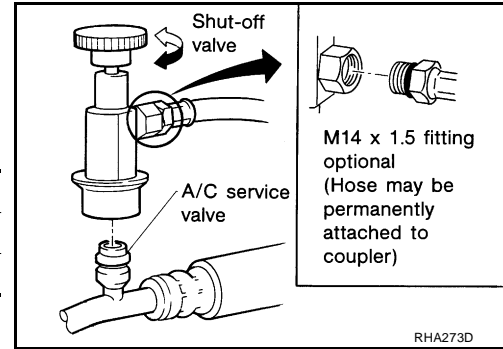

REFRIGERANT WEIGHT SCALE

Verify that no refrigerant other than HFC134a (R-134a) and specified oils have been used with the scale. If the scale controls refrigerant flow electronically, the hose fitting must be 1/2"-16 ACME.

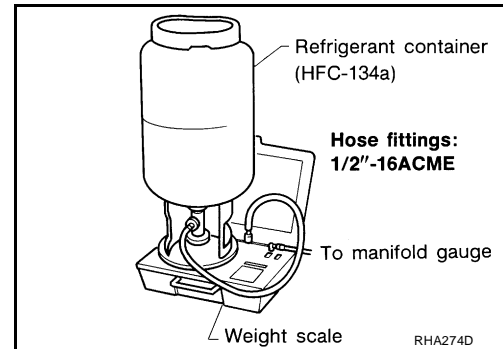

CHARGING CYLINDER

Using a charging cylinder is not recommended. Refrigerant may be vented into air from cylinder's top valve when filling the cylinder with refrigerant. Also, the accuracy of the cylinder is generally less than that of an electronic scale or of quality recycle/recharge equipment.

A
B
C
D
E
F
G
H
I
K
L
M

MTC

PREPARATION

PREPARATION

PFP:00002

Special Service Tools

EJS0050D

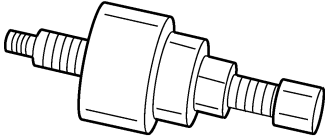
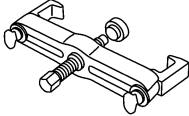

The actual shapes of Kent-Moore tools may differ from those of special service tools illustrated here.

Tool number (Kent-Moore No.) Tool name	Description
— (J-38873-A) Drive plate installer	Installing pulley and drive plate  WJIA0367E
KV99233130 (J-29884) Pulley puller	Removing pulley  LHA172



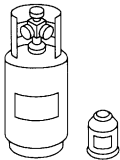

HFC-134a (R-134a) Service Tools and Equipment

EJS0050E

Never mix HFC-134a refrigerant and/or its specified oil with CFC-12 (R-12) refrigerant and/or its oil. Separate and non-interchangeable service equipment must be used for handling each type of refrigerant/oil. Refrigerant container fittings, service hose fittings and service equipment fittings (equipment which handles refrigerant and/or oil) are different between CFC-12 (R-12) and HFC-134a (R-134a). This is to avoid mixed use of the refrigerants/oil. Adapters that convert one size fitting to another must never be used: refrigerant/oil contamination will occur and compressor failure will result.

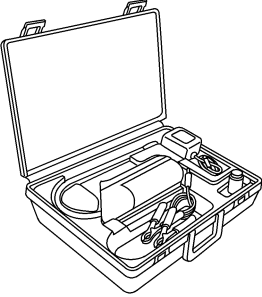
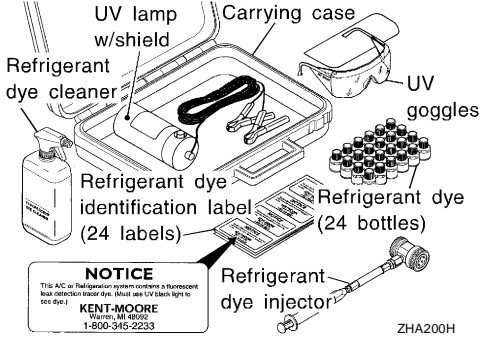
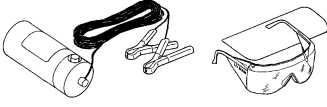
Tool number (Kent-Moore No.) Tool name	Description
— (—) Refrigerant HFC-134a (R-134a)	Container color: Light blue Container marking: HFC-134a (R-134a) Fitting size: Thread size ● large container 1/2 in -16 ACME  S-NT196
— (—) Genuine NISSAN A/C System Oil Type S	Type: Poly alkaline glycol oil (PAG), type S Application: HFC-134a (R-134a) swash plate compressors (NISSAN only) Lubricity: 40 m ℓ (1.4 US fl oz, 1.4 Imp fl oz)  S-NT197
K991J0130 (ACR2005-NI) ACR A/C Service Center	Refrigerant recovery, recycling and re-charging  WJIA0293E

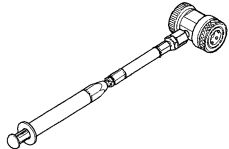
PREPARATION

Tool number (Kent-Moore No.) Tool name	Description
<p>— (J-41995) Electronic refrigerant leak detector</p>	<p>Power supply: DC 12V (Battery terminal)</p> <div style="text-align: center;">  <p>AHA281A</p> </div>
<p>— (J-43926) Refrigerant dye leak detection kit Kit includes: (J-42220) UV lamp and UV safety goggles (J-41459) Refrigerant dye injector (J-41447) qty. 24 HFC-134a (R-134a) refrigerant dye (J-43872) Refrigerant dye cleaner</p>	<p>Power supply: DC 12V (Battery terminal)</p> <div style="text-align: center;">  <p>ZHA200H</p> </div>
<p>— (J-42220) Fluorescent dye leak detector</p>	<p>Power supply: DC 12V (Battery terminal) For checking refrigerant leak when fluorescent dye is installed in A/C system. Includes: UV lamp and UV safety goggles</p> <div style="text-align: center;">  <p>SHA438F</p> </div>
<p>— (J-41447) HFC-134a (R-134a) Fluorescent leak detection dye (Box of 24, 1/4 ounce bottles)</p>	<p>Application: For HFC-134a (R-134a) PAG oil Container: 1/4 ounce (7.4cc) bottle (Includes self-adhesive dye identification labels for affixing to vehicle after charging system with dye.)</p> <div style="text-align: center;">  <p>Refrigerant dye (24 bottles)</p> <p>SHA439F</p> </div>
<p>— (J-41459) HFC-134a (R-134a) Dye injector Use with J-41447, 1/4 ounce bottle</p>	<p>For injecting 1/4 ounce of fluorescent leak detection dye into A/C system.</p> <div style="text-align: center;">  <p>SHA440F</p> </div>
<p>— (J-43872) Refrigerant dye cleaner</p>	<p>For cleaning dye spills.</p> <div style="text-align: center;">  <p>SHA441F</p> </div>

A
B
C
D
E
F
G
H
I
MTC
K
L
M

PREPARATION

Tool number (Kent-Moore No.) Tool name	Description
— (J-39183-C) Manifold gauge set (with hoses and couplers)	Identification: <ul style="list-style-type: none"> ● The gauge face indicates R-134a. Fitting size: Thread size ● 1/2 in -16 ACME
Service hoses <ul style="list-style-type: none"> ● (J-39500-72B) High side hose ● (J-39500-72R) Low side hose ● (J-39500-72Y) Utility hose 	Hose color: <ul style="list-style-type: none"> ● Low side hose: Blue with black stripe ● High side hose: Red with black stripe ● Utility hose: Yellow with black stripe or green with black stripe Hose fitting to gauge: <ul style="list-style-type: none"> ● 1/2 in -16 ACME
Service couplers <ul style="list-style-type: none"> ● (J-39500-20A) High side coupler ● (J-39500-24A) Low side coupler 	Hose fitting to service hose: <ul style="list-style-type: none"> ● M14 x 1.5 fitting is optional or permanently attached.
— (J-39649) Vacuum pump (Including the isolator valve)	Capacity: <ul style="list-style-type: none"> ● Air displacement: 4 CFM ● Micron rating: 20 microns ● Oil capacity: 482 g (17 oz) Fitting size: Thread size ● 1/2 in -16 ACME

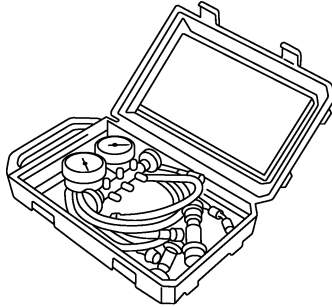

RJIA0196E

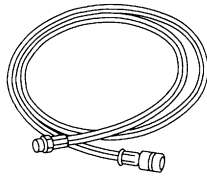

S-NT201

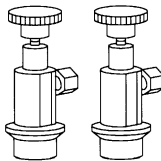

S-NT202

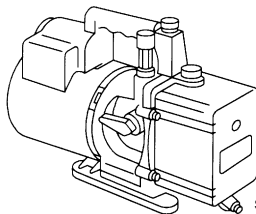

S-NT203

PREPARATION

Commercial Service Tools

EJS0050F

Tool number Tool name	Description	A
J-41810-NI Refrigerant identifier equipment HFC 134a (R-134a)	Checking refrigerant purity and system contamination	B
Power tool	Removing bolts and nuts	C
Universal spanner wrench	Holding compressor clutch for removal and installation	D
J-44614 Clutch disc holding tool	Holding clutch disc for removal and installation	E

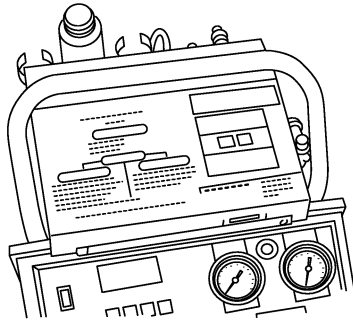

RJIA0197E

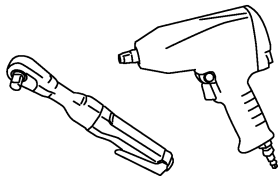

PBIC0190E

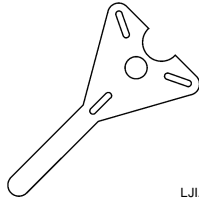

LJIA0202E

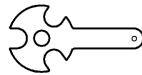

WHA230

A

B

C

D

E

F

G

H

I

MTC

K

L

M

REFRIGERATION SYSTEM

PFP:KA990

REFRIGERATION SYSTEM

Refrigerant Cycle REFRIGERANT FLOW

EJS0050G

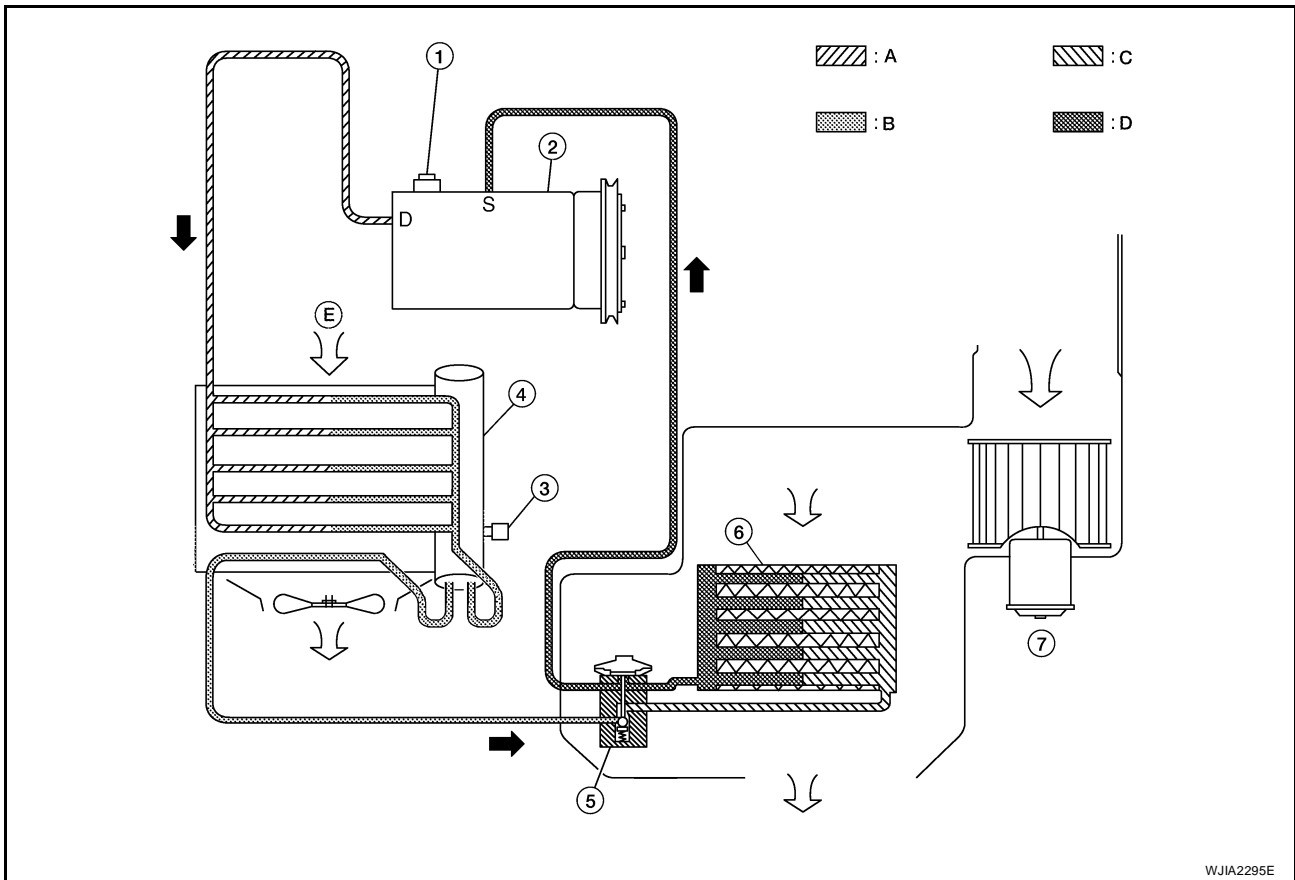

- | | | |
|---------------------------------|----------------------|--------------------------------|
| 1. Pressure relief valve | 2. Compressor | 3. Refrigerant pressure sensor |
| 4. Condenser (with liquid tank) | 5. Expansion valve | 6. Evaporator |
| 7. Front blower motor | A. High-pressure gas | B. High-pressure liquid |
| C. Low-pressure liquid | D. Low-pressure gas | E. Outside air |

The refrigerant flows in the standard pattern, that is, through the compressor, the condenser with liquid tank, through the evaporator, and back to the compressor. The refrigerant evaporation through the evaporator coil is controlled by an externally equalized expansion valve, located inside the evaporator case.

Refrigerant System Protection REFRIGERANT PRESSURE SENSOR

EJS0050H

The refrigerant system is protected against excessively high or low pressures by the refrigerant pressure sensor, located on the liquid tank. If the system pressure rises above or falls below the specifications, the refrigerant pressure sensor detects the pressure inside the refrigerant line and sends the voltage signal to the ECM. The ECM then signals the BCM (via CAN communication lines) to cease supplying power to the A/C relay which disengages and stops the compressor. This occurs when pressure on the high pressure side (as detected by refrigerant pressure sensor) is over approximately 2,746 kPa (28 kg/cm², 398 psi), or below approximately 120 kPa (1.22 kg/cm², 17.4 psi).

PRESSURE RELIEF VALVE

The refrigerant system is also protected by a pressure relief valve, located in the rear head of the compressor. When the refrigerant pressure in the system increases to an abnormal level [more than 3,600 kPa (36.7 kg/cm², 522 psi)], the release port on the pressure relief valve automatically opens and releases refrigerant into the atmosphere.

REFRIGERATION SYSTEM

Component Layout

EJS00501

SEC. 270 • 271 • 272 • 273

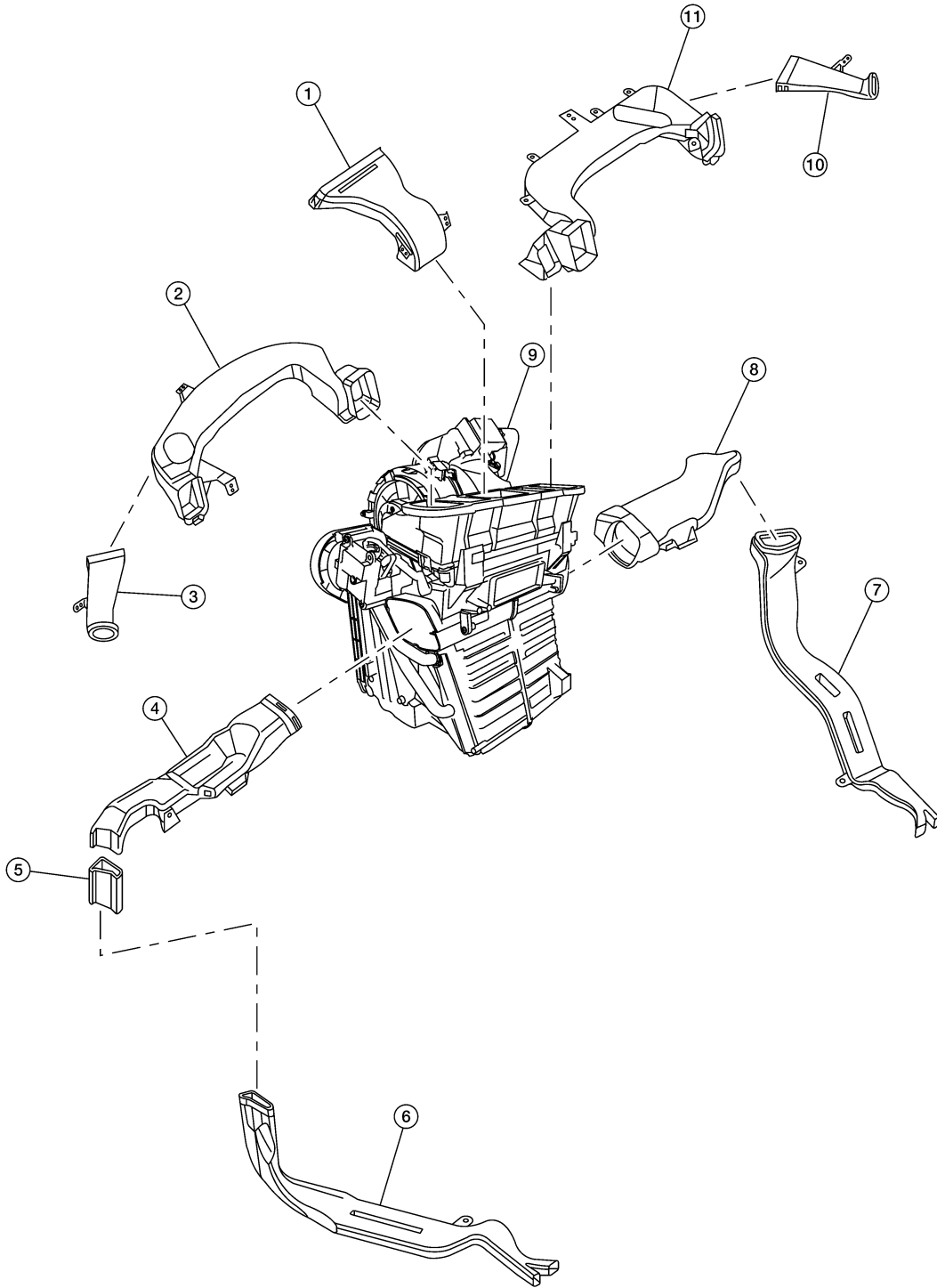

A
B
C
D
E
F
G
H
I
MTC
K
L
M

BJIA0023E

REFRIGERATION SYSTEM

- | | | |
|---------------------------------------|--|---------------------------------------|
| 1. Defroster nozzle | 2. Side ventilator duct (LH) | 3. Side defroster duct (LH) |
| 4. Front foot duct (LH) | 5. Rear floor connector duct (Canada only) | 6. Rear floor duct (LH) (Canada only) |
| 7. Rear floor duct (RH) (Canada only) | 8. Front foot duct (RH) | 9. Heater and cooling unit assembly |
| 10. Side defroster duct (RH) | 11. Side ventilator duct (RH) | |

OIL

PF:KLG00

OIL

Maintenance of Oil Quantity in Compressor

EJS0050J

The oil in the compressor circulates through the system with the refrigerant. Add oil to compressor when replacing any component or after a large refrigerant leakage has occurred. It is important to maintain the specified amount.

If oil quantity is not maintained properly, the following malfunctions may result:

- Lack of oil: May lead to a seized compressor
- Excessive oil: Inadequate cooling (thermal exchange interference)

OIL

- Oil type: NISSAN A/C System Oil Type S or equivalent

CHECKING AND ADJUSTING

CAUTION:

If excessive oil leakage is noted, do not perform the oil return operation.

Start the engine and set the following conditions:

Test Condition

- Engine speed: Idling to 1,200 rpm
- A/C switch: On
- Blower fan speed: Max. position
- Temp. control: Optional [Set so that intake air temperature is 25° to 30° C (77° to 86°F).]
- Intake position: Recirculation ()
- Perform oil return operation for about ten minutes

Adjust the oil quantity according to the following table.

Oil Adjusting Procedure for Components Replacement Except Compressor

After replacing any of the following major components, add the correct amount of oil to the system.

Amount of Oil to be Added

Part replaced	Oil to be added to system	Remarks
	Amount of oil m ℓ (US fl oz, Imp fl oz)	
Evaporator	75 (2.5, 2.6)	—
Condenser	75 (2.5, 2.6)	—
Liquid tank	5 (0.2, 0.2)	Add if compressor is not replaced.
In case of refrigerant leak	30 (1.0, 1.1)	Large leak
	—	Small leak *1

*1: If refrigerant leak is small, no addition of oil is needed.

OIL

Oil Adjustment Procedure for Compressor Replacement

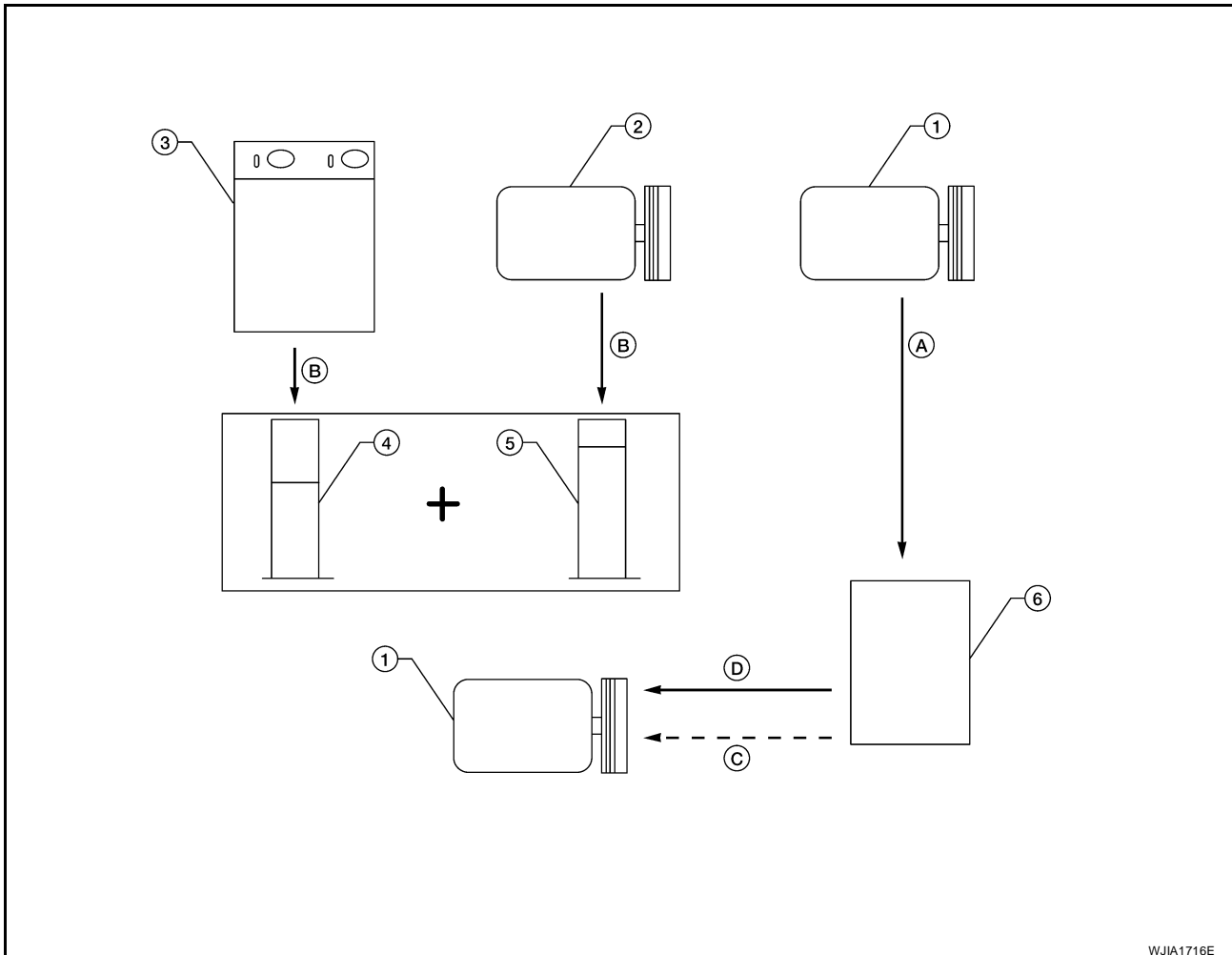

WJJA1716E

- | | | |
|---|-----------------------------------|---|
| 1. New compressor | 2. Old compressor | 3. Recovery/recycling equipment |
| 4. Measuring cup X | 5. Measuring cup Y | 6. New oil |
| A. Drain oil from the new compressor into clean container | B. Record amount of oil recovered | C. Add an additional 5 mℓ (0.2 US fl oz, 0.2 Imp fl oz) of new oil when replacing liquid tank |
| D. Install new oil equal to recorded amounts in measuring cups X plus Y | | |

1. Before connecting recovery/recycling equipment to vehicle, check recovery/recycling equipment gauges. No refrigerant pressure should be displayed. If NG, recover refrigerant from equipment lines.
2. Connect recovery/recycling equipment to vehicle. Confirm refrigerant purity in supply tank using recovery/recycling equipment and refrigerant identifier. If NG, refer to [MTC-4, "Contaminated Refrigerant"](#).
3. Confirm refrigerant purity in vehicle A/C system using recovery/recycling equipment and refrigerant identifier. If NG, refer to [MTC-4, "Contaminated Refrigerant"](#).
4. Discharge refrigerant into the refrigerant recovery/recycling equipment. Measure oil discharged into the recovery/recycling equipment.
5. Drain the oil from the "old" (removed) compressor into a graduated container and recover the amount of oil drained.
6. Drain the oil from the "new" compressor into a separate, clean container.
7. Measure an amount of new oil installed equal to amount drained from "old" compressor. Add this oil to "new" compressor through the suction port opening.
8. Measure an amount of new oil equal to the amount recovered during discharging. Add this oil to "new" compressor through the suction port opening.
9. If the liquid tank also needs to be replaced, add an additional 5 mℓ (0.2 US fl oz, 0.2 Imp fl oz) of oil at this time.

OIL

CAUTION:

Do not add this 5 mℓ (0.2 US fl oz, 0.2 Imp fl oz) of oil if only replacing the compressor and not the liquid tank.

A

B

C

D

E

F

G

H

I

MTC

K

L

M

AIR CONDITIONER CONTROL

AIR CONDITIONER CONTROL

PFP:27500

Overview Air Conditioner LAN Control System

EJS0050K

The LAN (local area network) system consists of front air control, air mix door motor, intake door motor, and mode door motor.

A configuration of these components is shown in the diagram below.

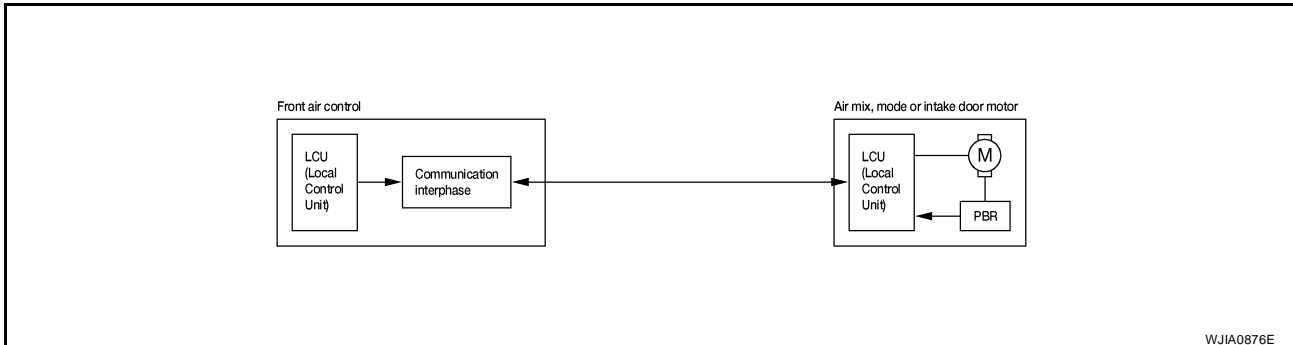

System Construction

EJS0050L

A small network is constructed between the front air control, air mix door motor, intake door motor, and mode door motor. The front air control and motors are connected by data transmission lines and motor power supply lines. The LAN network is built through the ground circuits of the two motors.

Addresses, motor opening angle signals, motor stop signals and error checking messages are all transmitted through the data transmission lines connecting the front air control and each motor.

The following functions are contained in LCUs built into the air mix door motor, intake door motor, and the mode door motor.

- Address
- Motor opening angle signals
- Data transmission
- Motor stop and drive decision
- Opening angle sensor (PBR function)
- Comparison
- Decision (front air control indicated value and motor opening angle comparison)

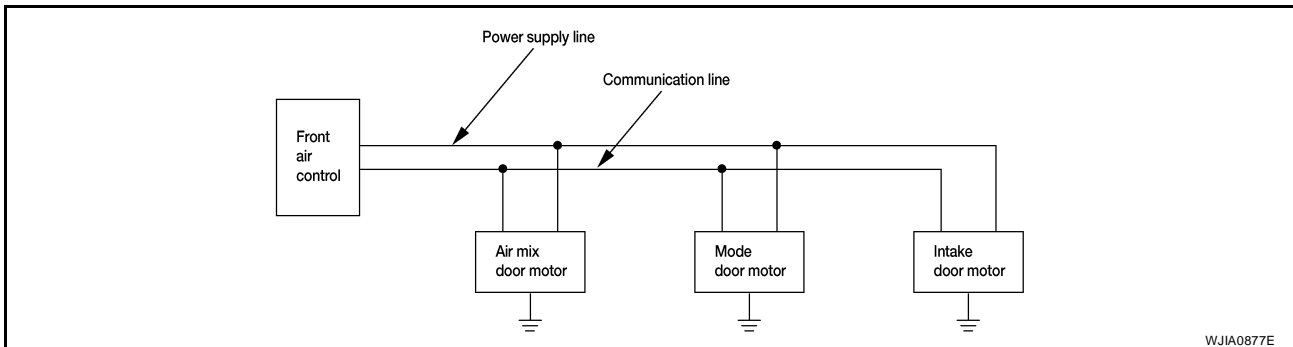

OPERATION

The front air control receives signals from its various dials and switches. The front air control then sends air mix door, mode door and intake door opening angle data to the air mix door motor LCU, mode door motor LCU and intake door motor LCU.

The air mix door motor, mode door motor and intake door motor read their respective signals according to the address signal. Opening angle indication signals received from the front air control and each of the motor position sensors are compared by the LCUs in each motor with the existing decision and opening angles. Subse-

AIR CONDITIONER CONTROL

quently, HOT/COLD, DEFROST/VENT or FRESH/RECIRCULATION operation is selected. The new selection data is returned to the front air control.

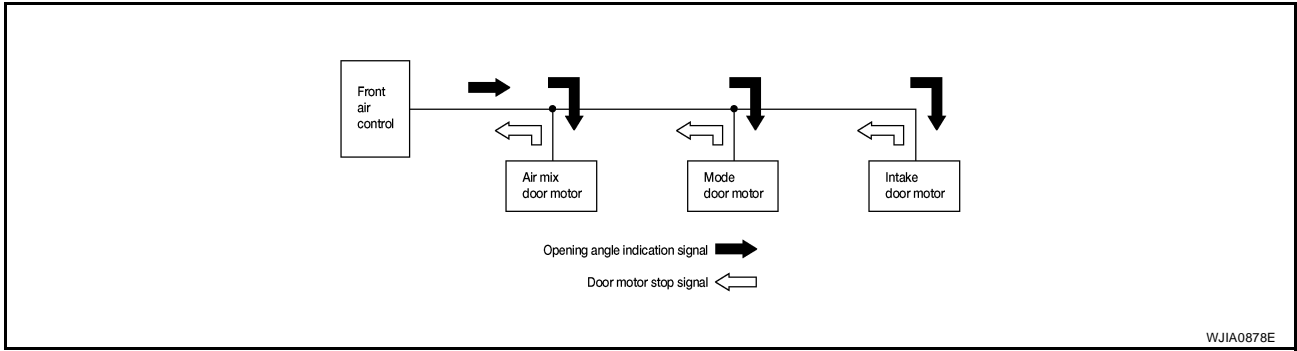

TRANSMISSION DATA AND TRANSMISSION ORDER

Front air control data is transmitted consecutively to each of the door motors following the form shown in figure below.

Start: Initial compulsory signal sent to each of the door motors.

Address: Data sent from the front air control is selected according to data-based decisions made by the air mix door motor, mode door motor and intake door motor.

If the addresses are identical, the opening angle data and error check signals are received by the door motor LCUs. The LCUs then make the appropriate error decision. If the opening angle data is normal, door control begins.

If an error exists, the received data is rejected and corrected data received. Finally, door control is based upon the corrected opening angle data.

Opening angle: Data that shows the indicated door opening angle of each door motor.

Error check: Procedure by which sent and received data is checked for errors. Error data is then compiled. The error check prevents corrupted data from being used by the air mix door motor, mode door motor and intake door motor. Error data can be related to the following problems.

- Abnormal electrical frequency
- Poor electrical connections
- Interference from other signal transmission lines
- Signal level fluctuation

Stop signal: At the end of each transmission, a stop operation, in-operation, or internal problem message is delivered to the front air control. This completes one data transmission and control cycle.

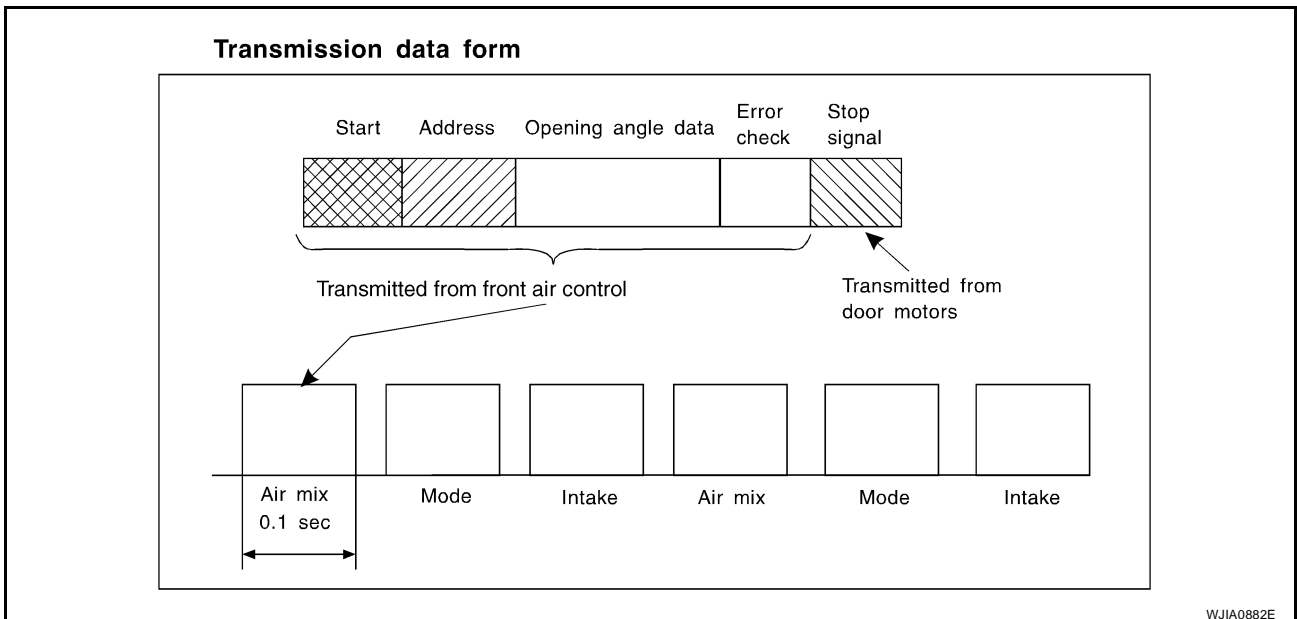

AIR MIX DOOR CONTROL

The air mix door is controlled by the front air control based on input from the temperature dial setting.

AIR CONDITIONER CONTROL

BLOWER SPEED CONTROL

Blower speed is controlled by the front air control based on the position of the blower control dial. With the blower control dial set to any position except OFF, the blower will begin to operate.

INTAKE DOOR CONTROL

The intake door is controlled by the front air control based on input from the recirculation switch setting, and the MAX A/C switch setting.

MODE DOOR CONTROL

The mode door is controlled by the front air control based on input from the mode dial setting.

MAGNET CLUTCH CONTROL

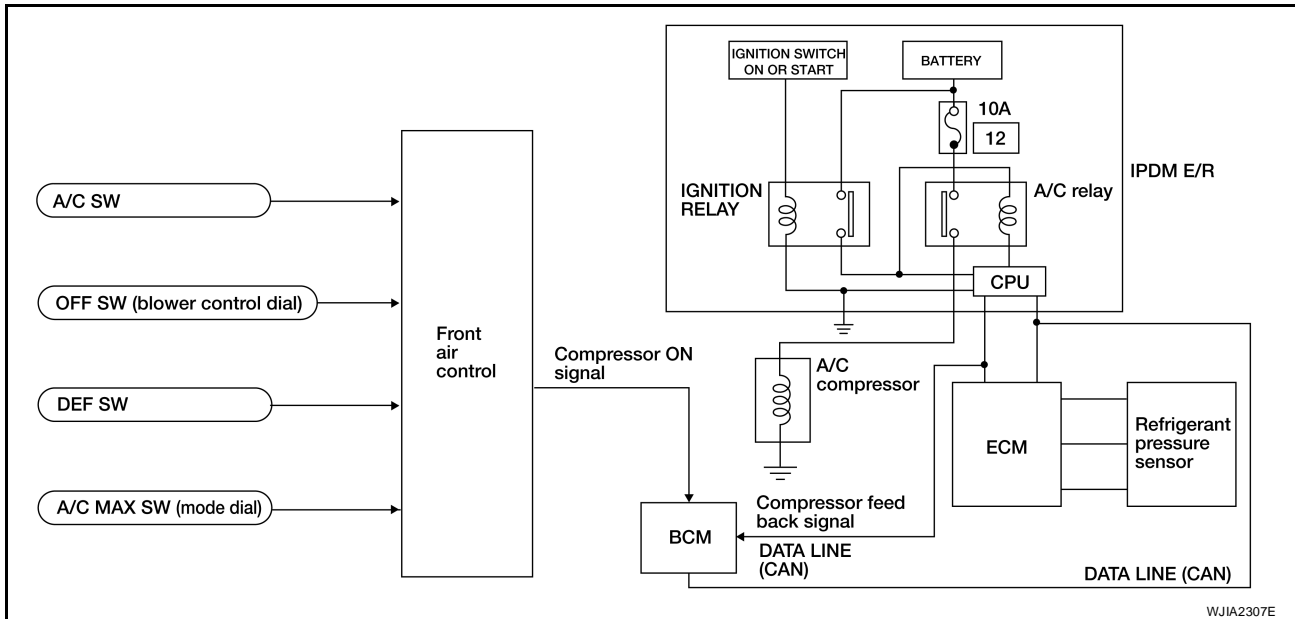

The ECM controls compressor operation using input signals from the throttle position sensor and front air control.

Overview of Control system

EJS0050M

The control system consists of an input sensor, switches, the front air control and outputs.

AIR CONDITIONER CONTROL

The relationship of these components is shown in the diagram below:

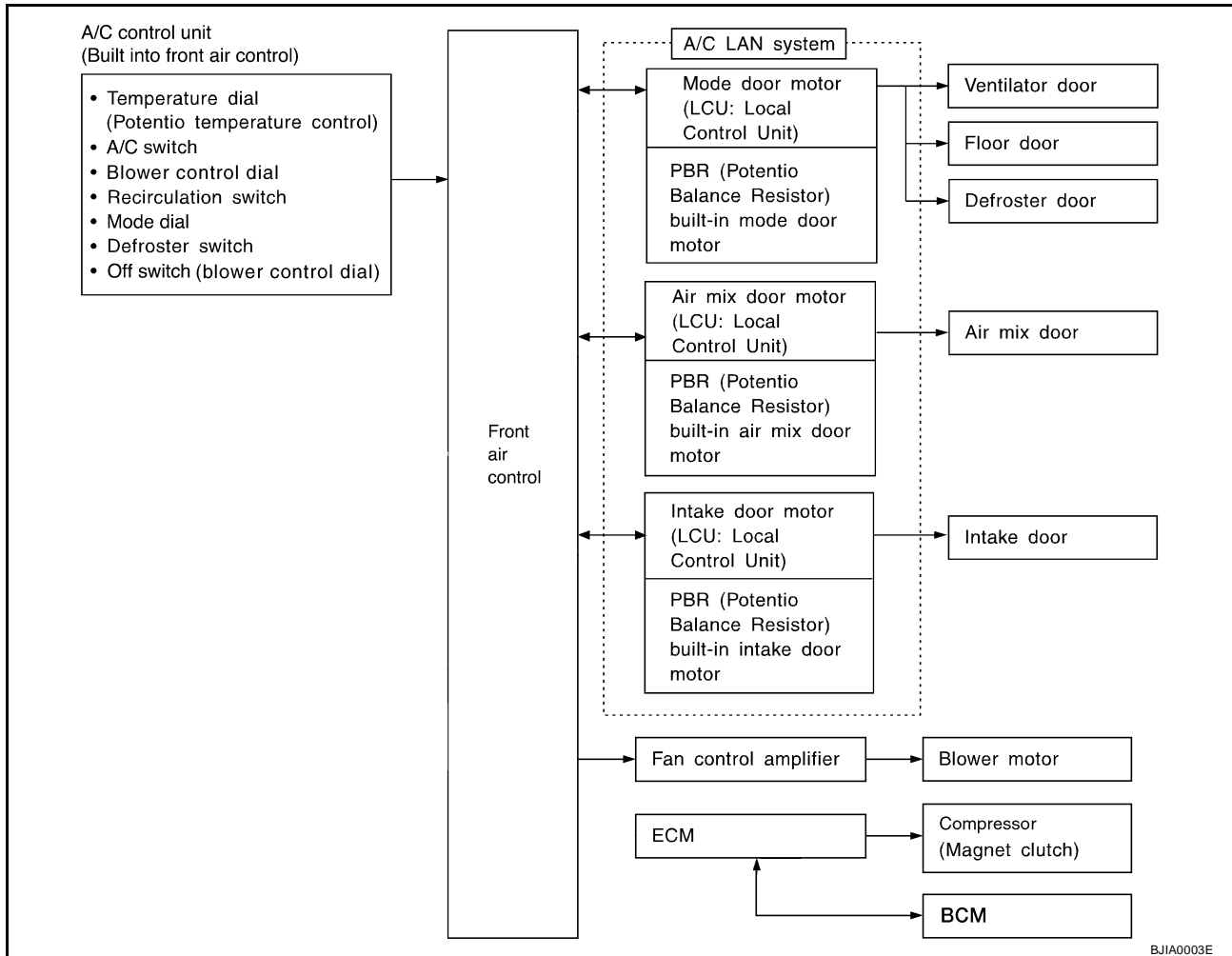

Control Operation

EJS0050N

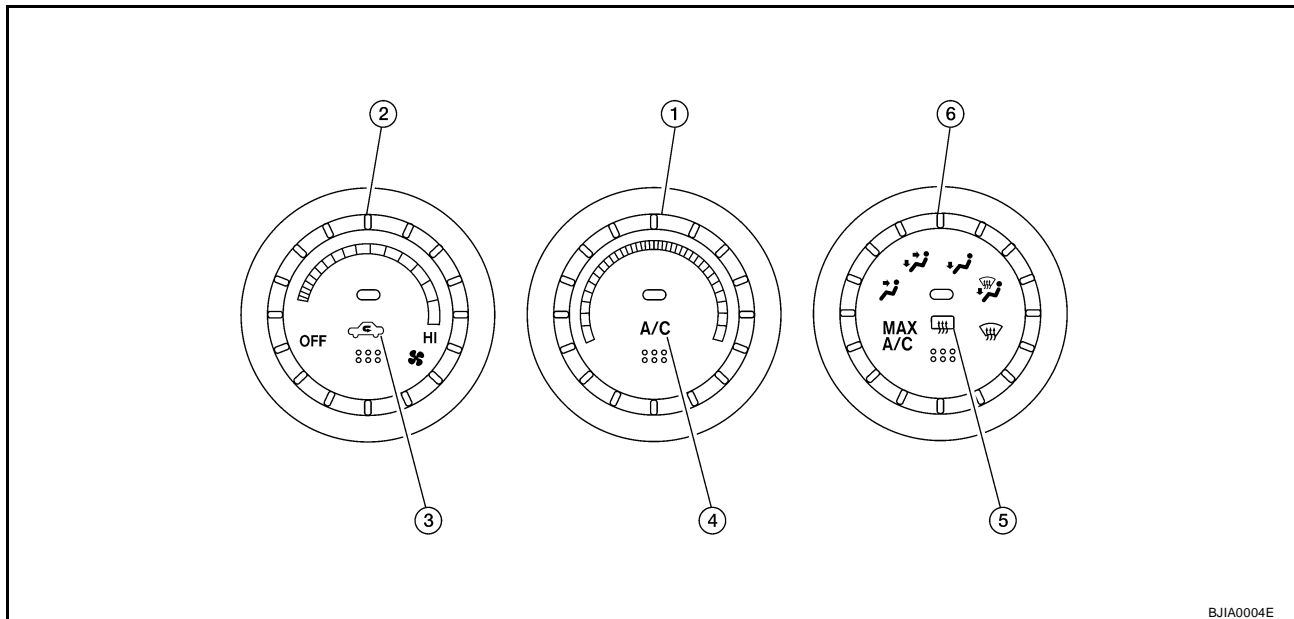

A
B
C
D
E
F
G
H
I
MTC

K
L
M

AIR CONDITIONER CONTROL

AIR CONDITIONER (A/C) SWITCH

The air conditioner switch controls the A/C system. When the switch is pressed with the blower ON, the compressor will turn ON. The indicator lamp will also illuminate.

The air conditioner cooling function operates only when the engine is running.

TEMPERATURE DIAL (POTENTIO TEMPERATURE CONTROL)

Increases or decreases the set temperature.

BLOWER CONTROL DIAL/OFF SWITCH

Manually controls the blower speed.

In the off position, the compressor and blower are OFF, the intake door is set to the chosen position, and the air mode doors are set to the chosen position.

RECIRCULATION () SWITCH

OFF position: Outside air is drawn into the passenger compartment.

ON position: Interior air is recirculated inside the vehicle.

DEFROSTER SWITCH

Positions the air mode doors to the defrost position. Also positions the intake doors to the outside air position. The compressor remains ON until the ignition is turned OFF or if the customer turns the mode to a non-defrost mode and turns the A/C button to OFF.

MODE DIAL

Controls the air discharge through control of mode door, also controls MAX A/C function.

REAR WINDOW DEFOGGER SWITCH

This switch turns the rear window defogger ON and OFF.

AIR CONDITIONER CONTROL

Discharge Air Flow

EJS00500

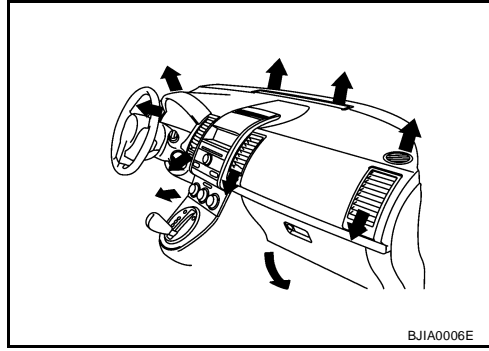

Mode door position	Air outlet/distribution		
	Vent	Foot	Defroster
	100%	—	—
	60%	40%	—
	10%	60%	30%
	11%	50%	39%
	15%	—	85%

Airflow always present at driver and passenger side demisters

A
B
C
D
E
F
G
H
I

MTC

K
L
M

AIR CONDITIONER CONTROL

EJS0050P

System Description SWITCHES AND THEIR CONTROL FUNCTION

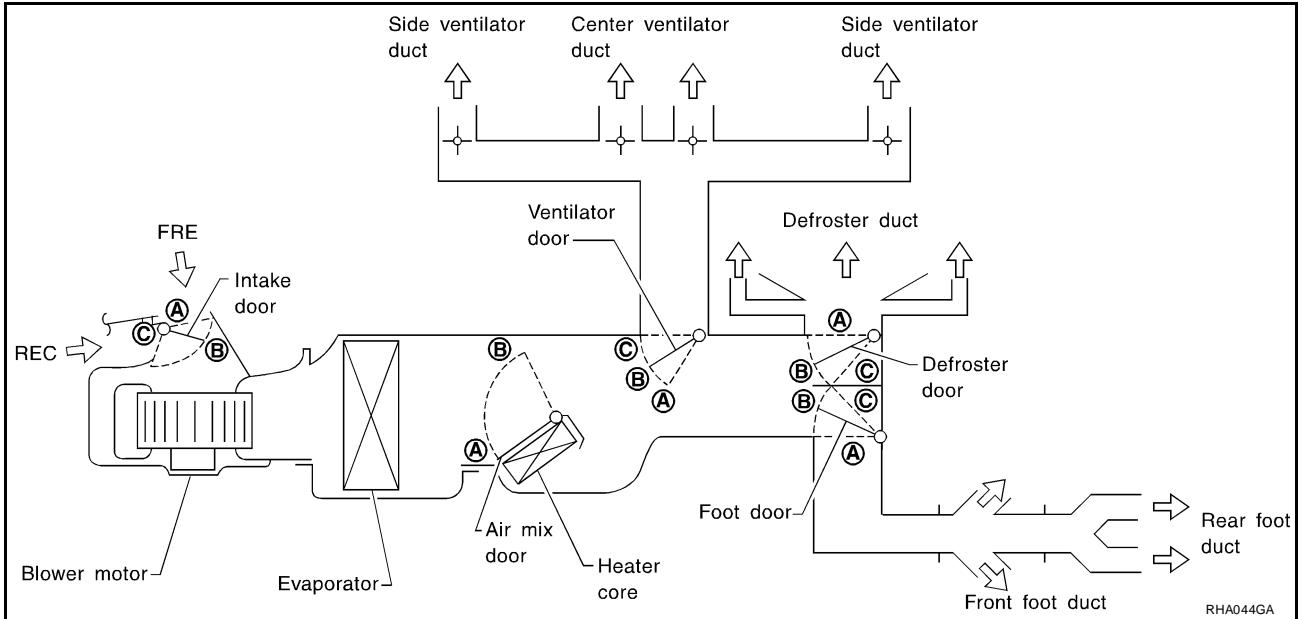

RHA044GA

Position or switch	MODE DIAL						REC SW		Temperature DIAL		
	VENT	B/L	FOOT	D/F	DEF	MAX A/C	ON	OFF			
Door									COLD	—	HOT
Ventilator door	A	B	C*	C*	C*	A	—	—	—		
Foot door	A	B	C	B	A	A	—	—	—		
Defroster door	A	A	B	B	C	A	—	—	—		
Air mix door	—						—	—	A	—	B
Intake door	—				C	A	A	C	—		

* Side outboard vents have bypass airflow

WJIA2294E

CAN Communication System Description

EJS0050Q

Refer to [LAN-4, "SYSTEM DESCRIPTION"](#).

TROUBLE DIAGNOSIS

TROUBLE DIAGNOSIS

PFP:00004

How to Perform Trouble Diagnoses for Quick and Accurate Repair WORK FLOW

EJS0050R

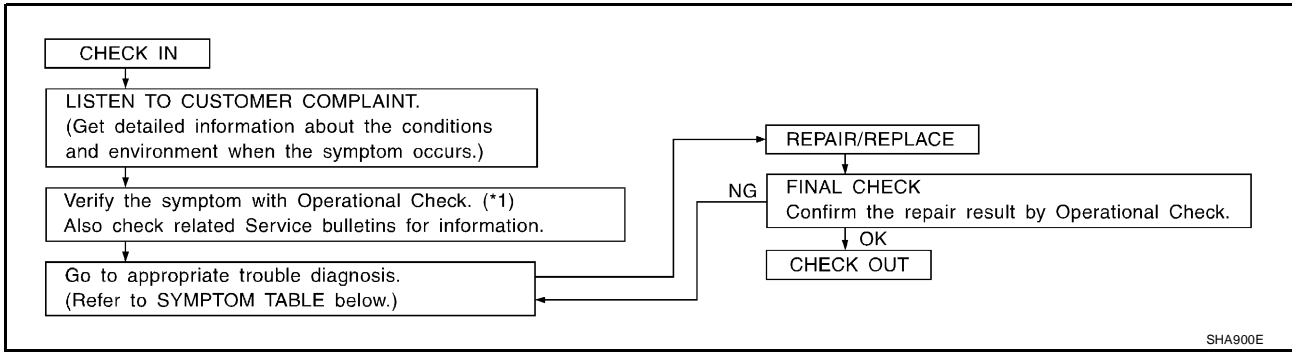

SHA900E

*1: [MTC-43, "Operational Check"](#)

SYMPTOM TABLE

Symptom		Reference Page
● A/C system does not come on.	● Go to Trouble Diagnosis Procedure for A/C system.	MTC-44
● Air outlet does not change.	● Go to Trouble Diagnosis Procedure for Mode Door Motor. (LAN)	MTC-50
● Mode door motor does not operate normally.		
● Discharge air temperature does not change.	● Go to Trouble Diagnosis Procedure for Air Mix Door Motor. (LAN)	MTC-52
● Air mix door motor does not operate normally.		
● Intake door does not change.	● Go to Trouble Diagnosis Procedure for Intake Door Motor. (LAN)	MTC-54
● Intake door motor does not operate normally.		
● Blower motor operation is malfunctioning.	● Go to Trouble Diagnosis Procedure for Blower Motor.	MTC-56
● Magnet clutch does not engage.	● Go to Trouble Diagnosis Procedure for Magnet Clutch.	MTC-62
● Insufficient cooling.	● Go to Trouble Diagnosis Procedure for Insufficient Cooling.	MTC-66
● Insufficient heating.	● Go to Trouble Diagnosis Procedure for Insufficient Heating.	MTC-74
● Noise.	● Go to Trouble Diagnosis Procedure for Noise.	MTC-76

TROUBLE DIAGNOSIS

Component Parts and Harness Connector Location ENGINE COMPARTMENT - QR25DE

EJS0050S

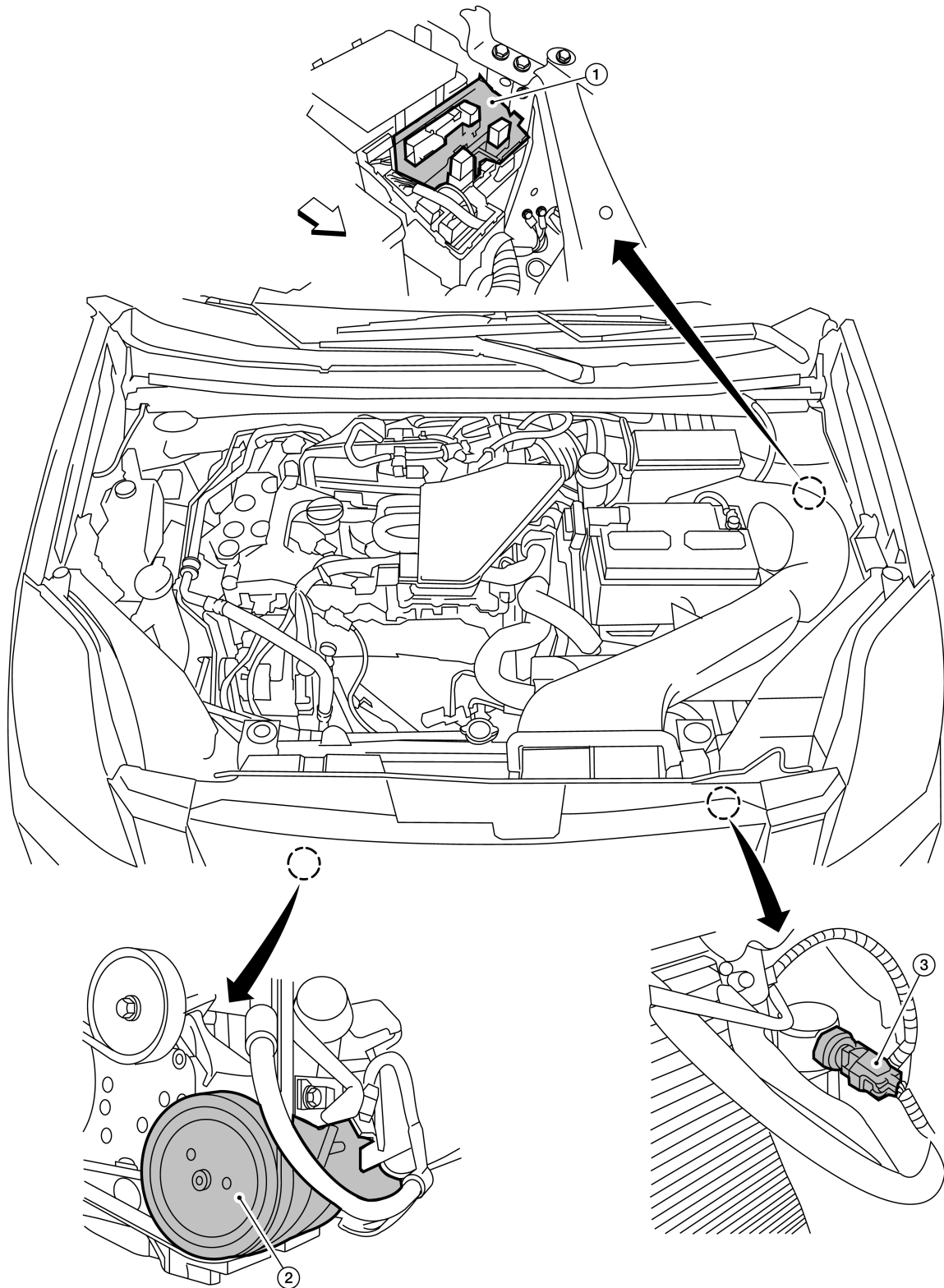

1. A/C relay (internal to the IPDM E/R) 2. A/C Compressor F3

3. Refrigerant pressure sensor E35
(view with grille removed)

WJIA2303E

TROUBLE DIAGNOSIS

ENGINE COMPARTMENT - MR20DE

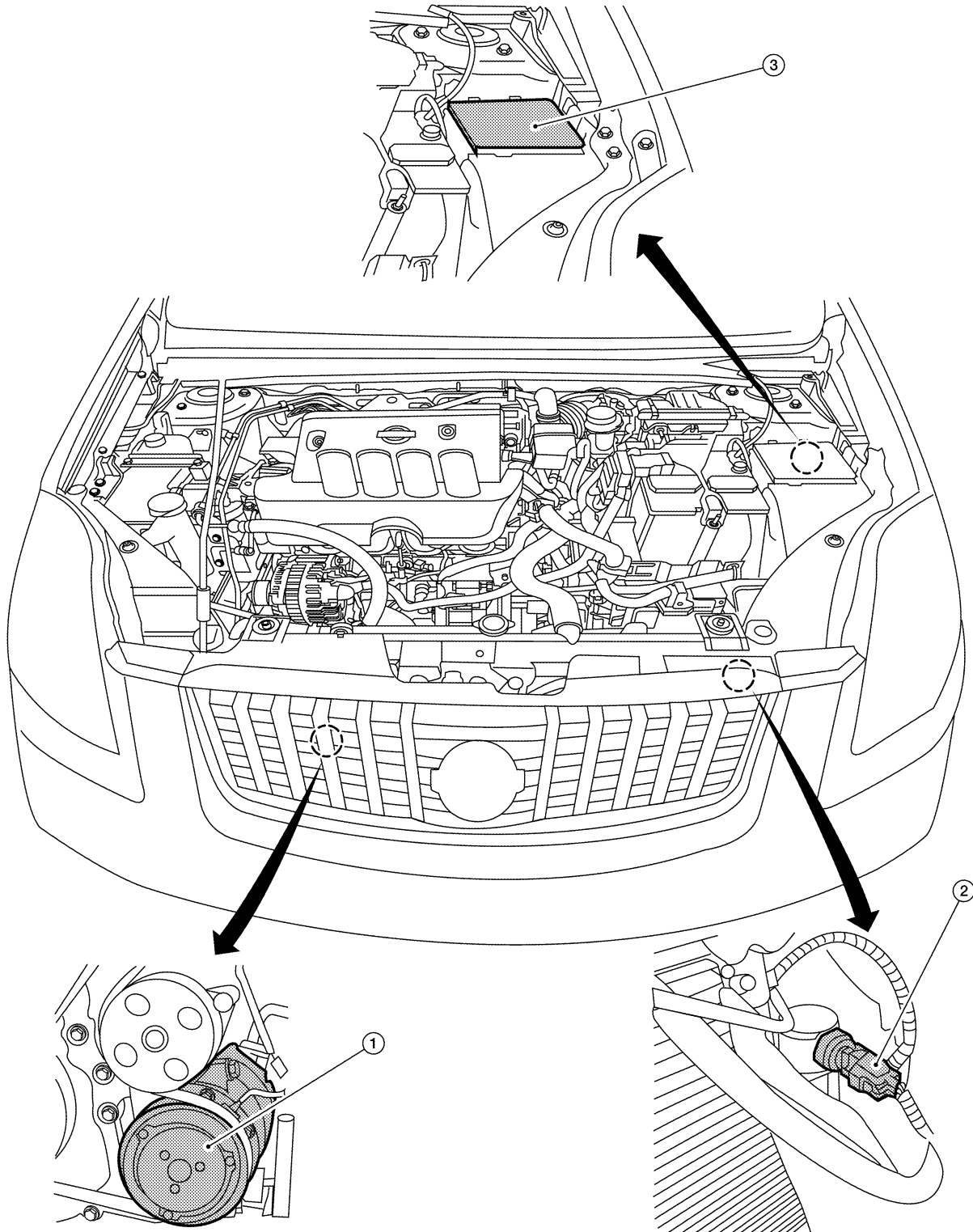

1. A/C Compressor F3

2. Refrigerant pressure sensor E35
(view with grille removed)

3. A/C relay (internal to the IPDM E/R)

BJIA001E

TROUBLE DIAGNOSIS

PASSENGER COMPARTMENT

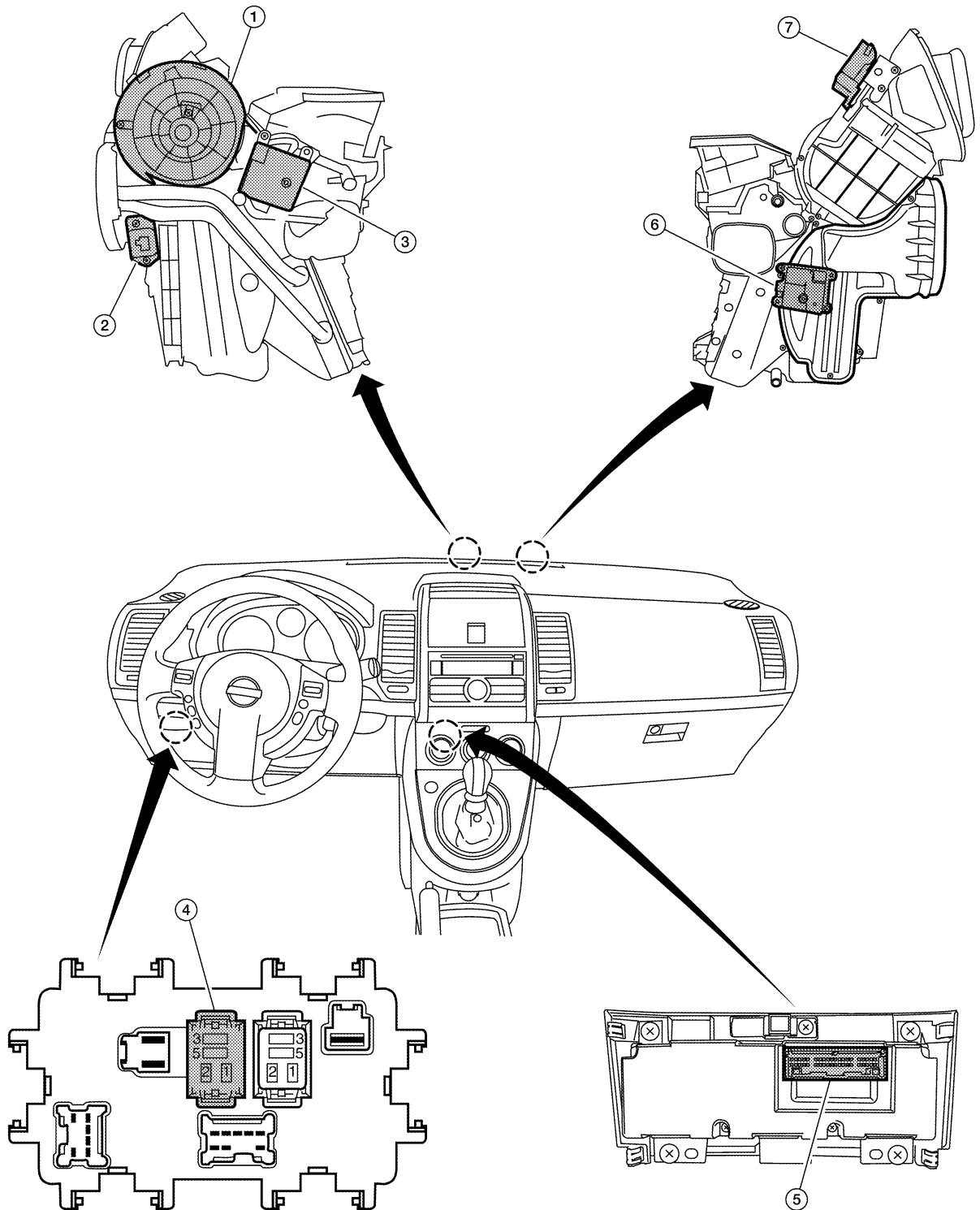

BJIA0012E

- | | | |
|--------------------------------|--------------------------|---------------------------|
| 1. Front blower motor M62 | 2. Fan control amp. M52 | 3. Mode door motor M51 |
| 4. Front blower motor relay J1 | 5. Front air control M33 | 6. Air mix door motor M34 |
| 7. Intake door motor M48 | | |

TROUBLE DIAGNOSIS

Circuit Diagram

EJS0050T

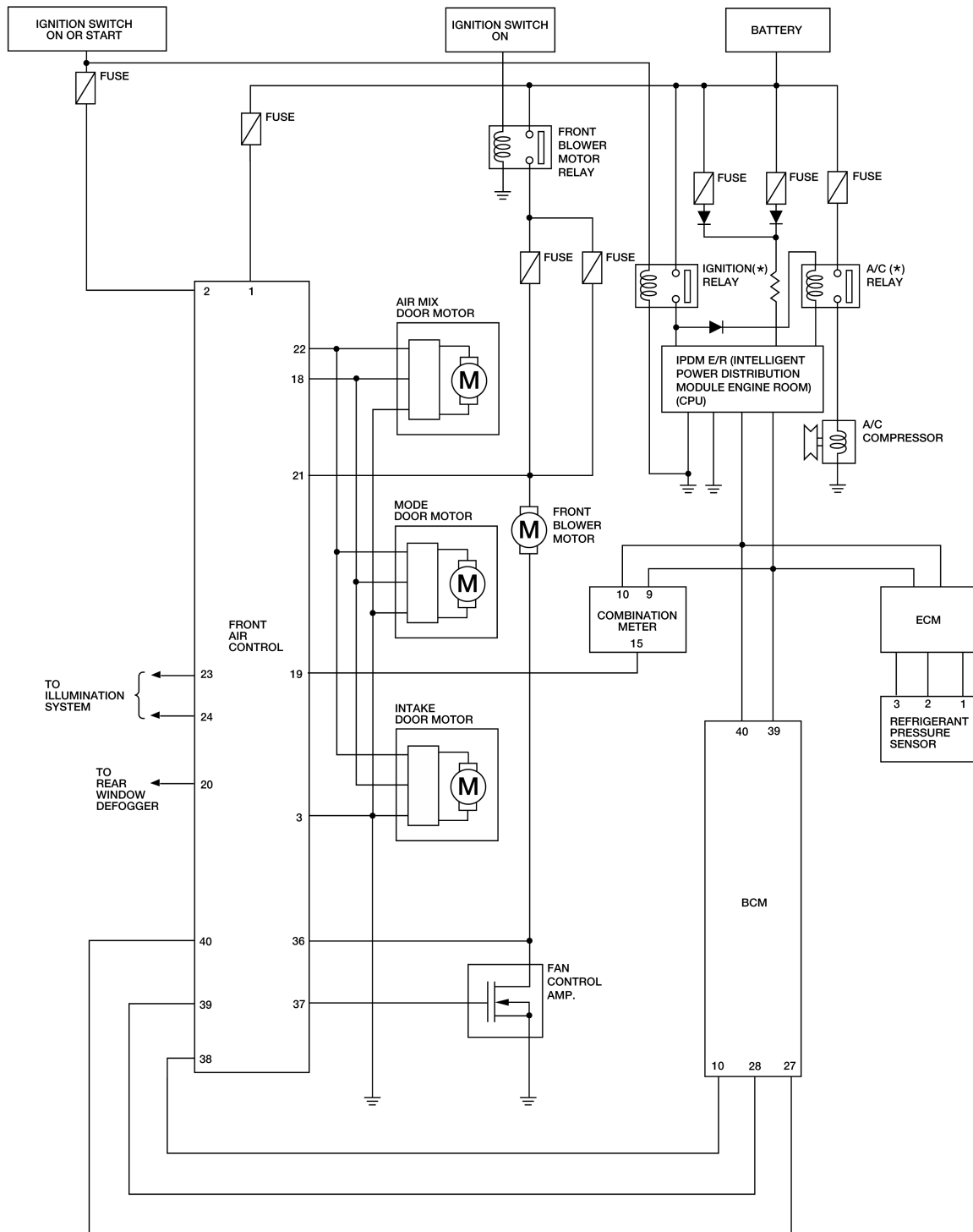

* : THIS RELAY IS BUILT INTO THE IPDM E/R (INTELLIGENT POWER DISTRIBUTION MODULE ENGINE ROOM)

WJWA0490E

A
B
C
D
E
F
G
H
I
J
K
L
M

MTC

TROUBLE DIAGNOSIS

Wiring Diagram — HEATER —

EJS0050U

MTC-HEATER-01

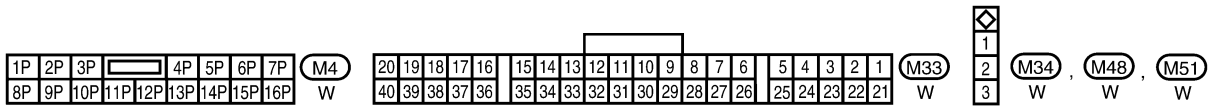
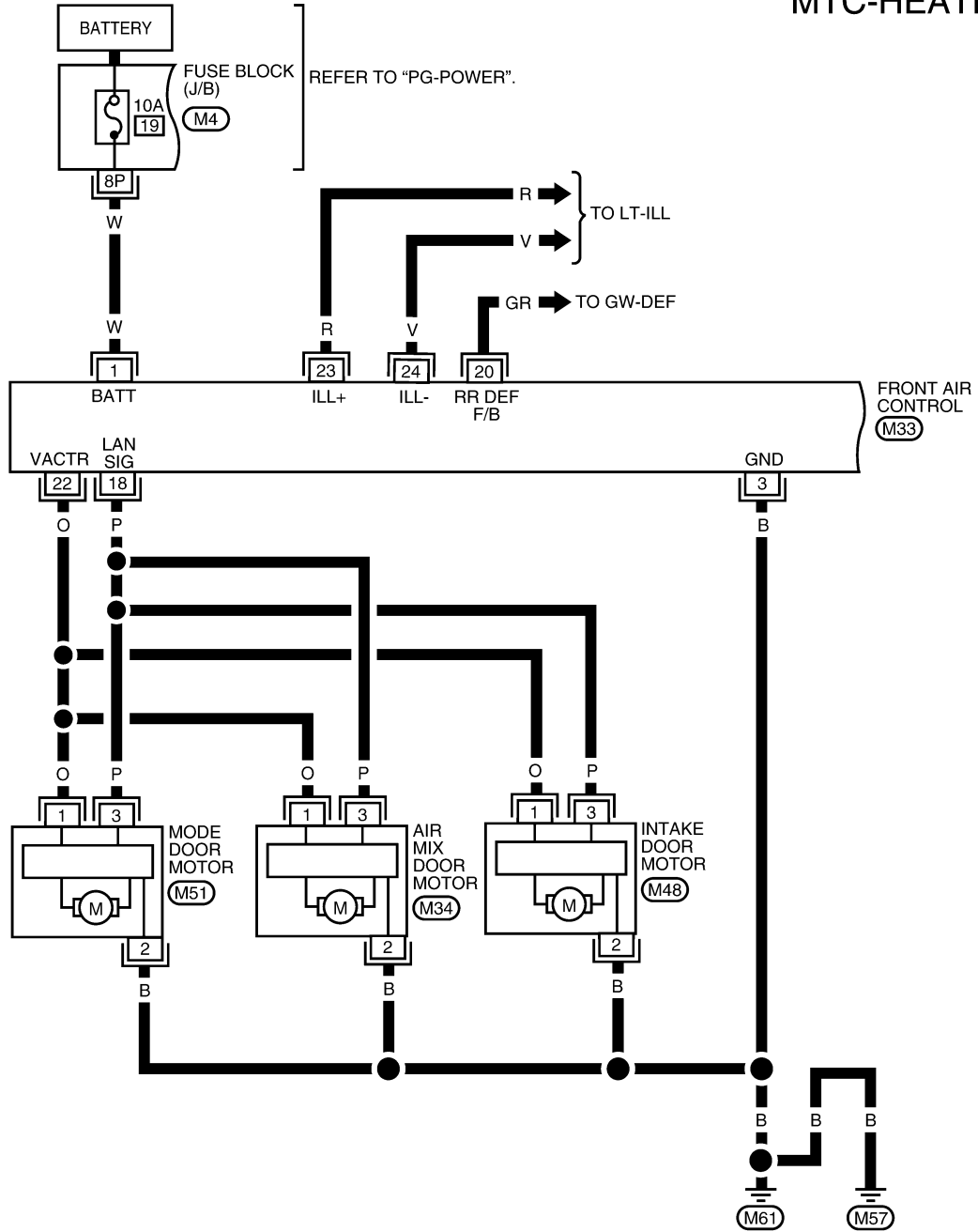

WJWA0468E

TROUBLE DIAGNOSIS

MTC-HEATER-02

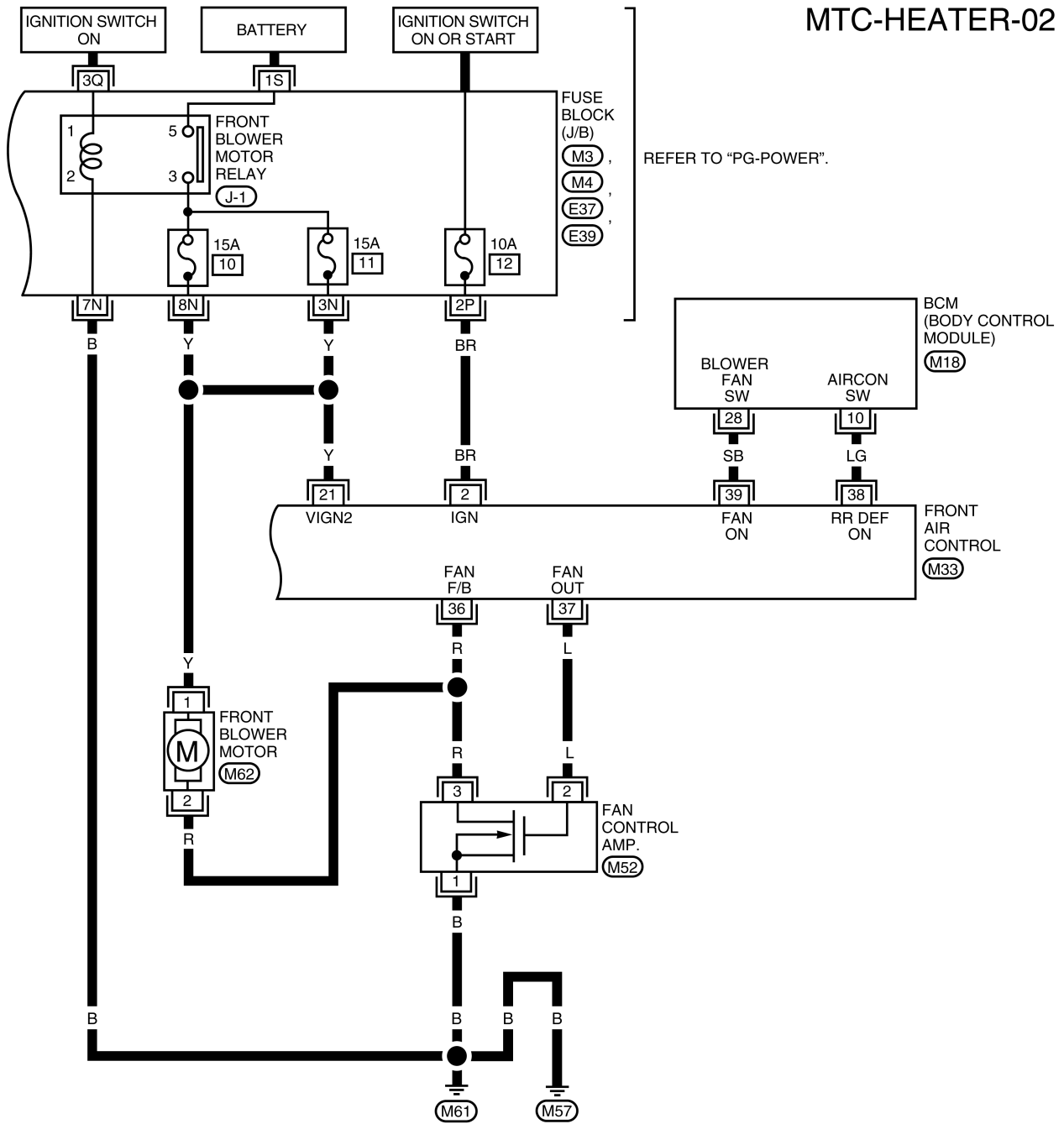

A
B
C
D
E
F
G
H
I
MTC
K
L
M

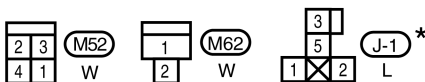
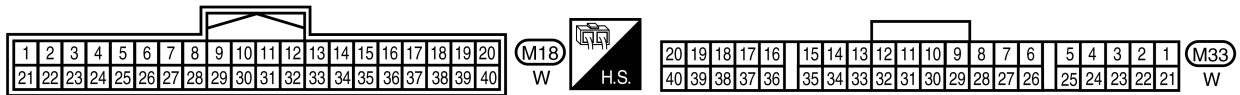
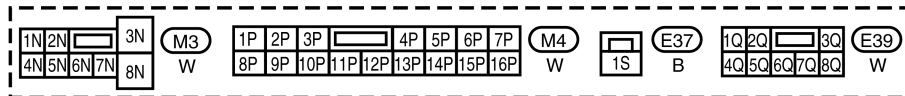

*: THIS CONNECTOR IS NOT SHOWN IN "HARNESS LAYOUT" OF PG SECTION.

WJWA0501E

TROUBLE DIAGNOSIS

Wiring Diagram — A/C,M —

EJS0050V

MTC-A/C,M-01

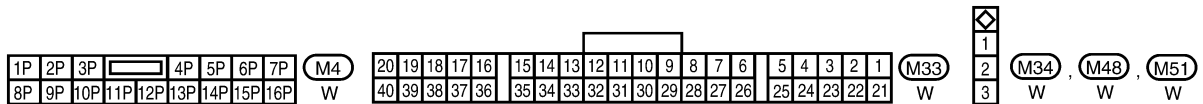
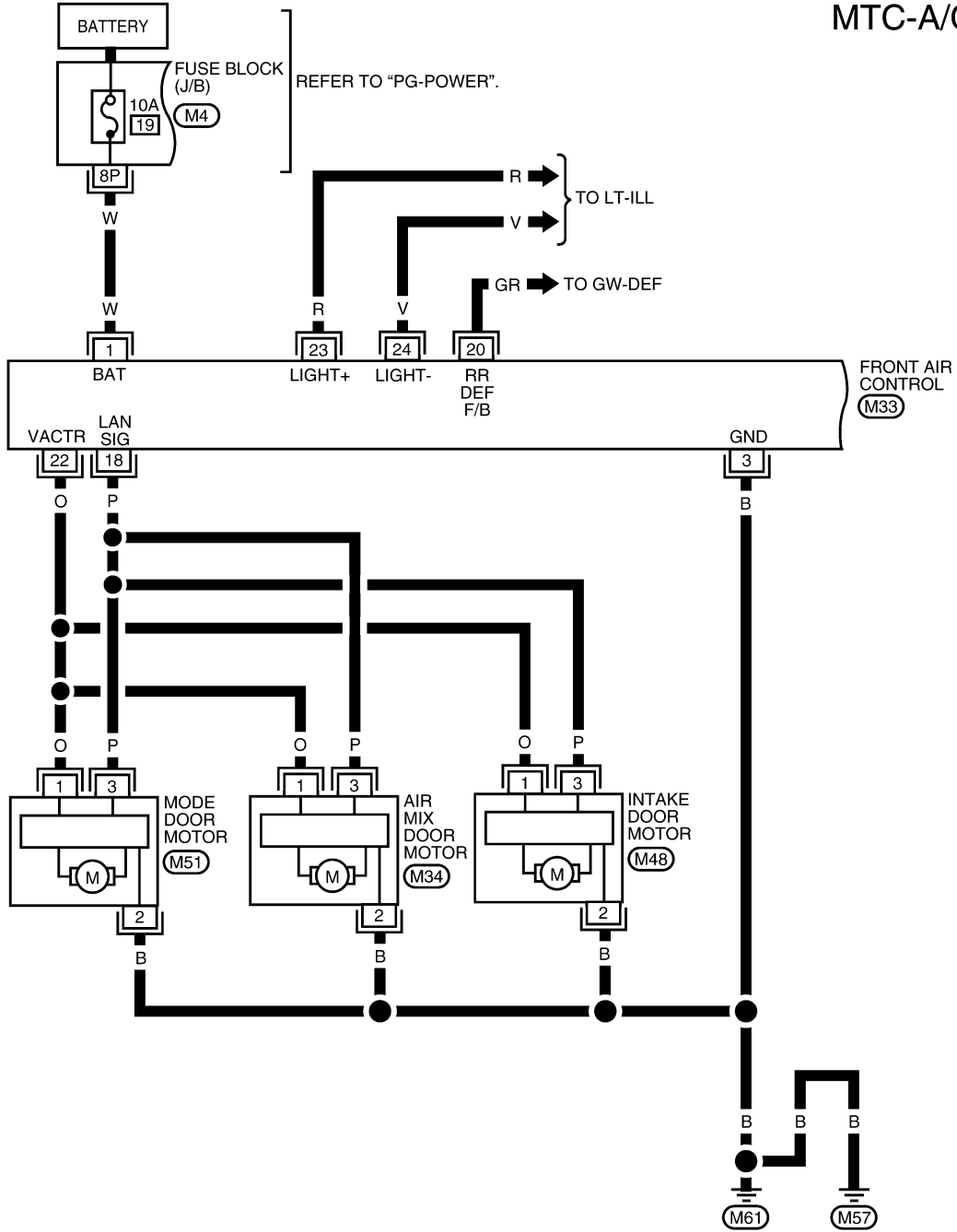

WJWA0470E

TROUBLE DIAGNOSIS

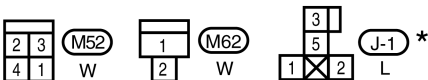
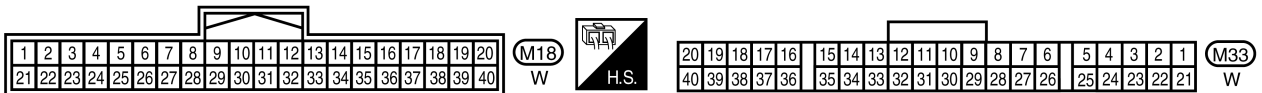
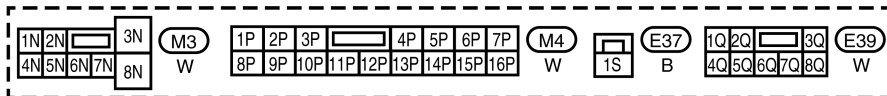
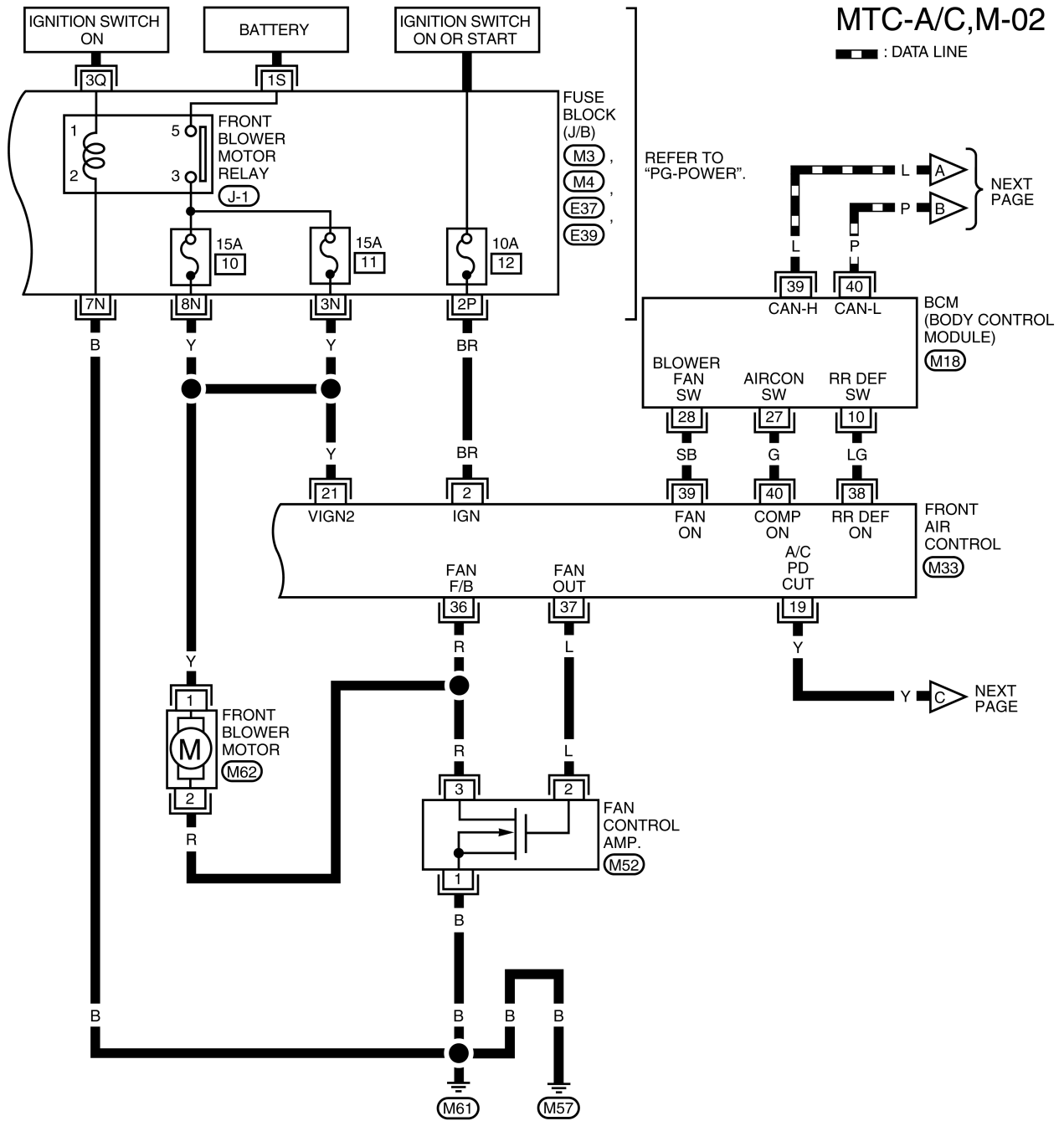

*: THIS CONNECTOR IS NOT SHOWN IN "HARNESS LAYOUT" OF PG SECTION.

WJWA0502E

TROUBLE DIAGNOSIS

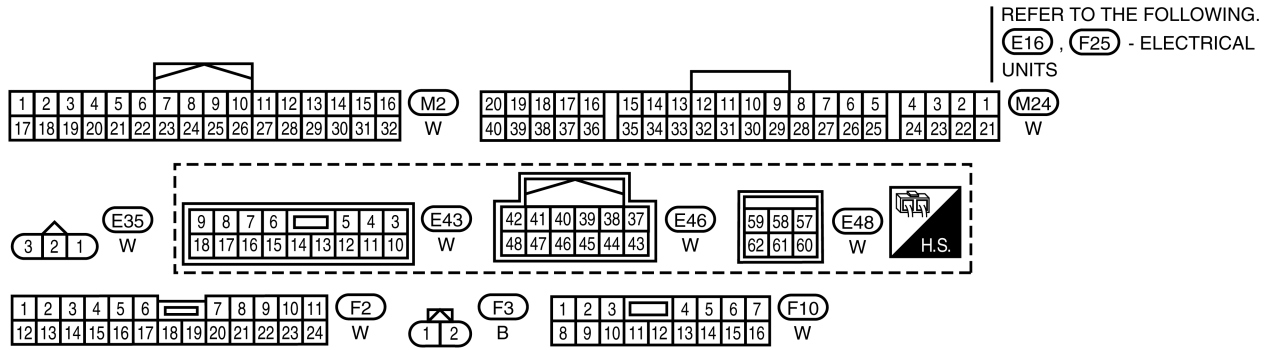
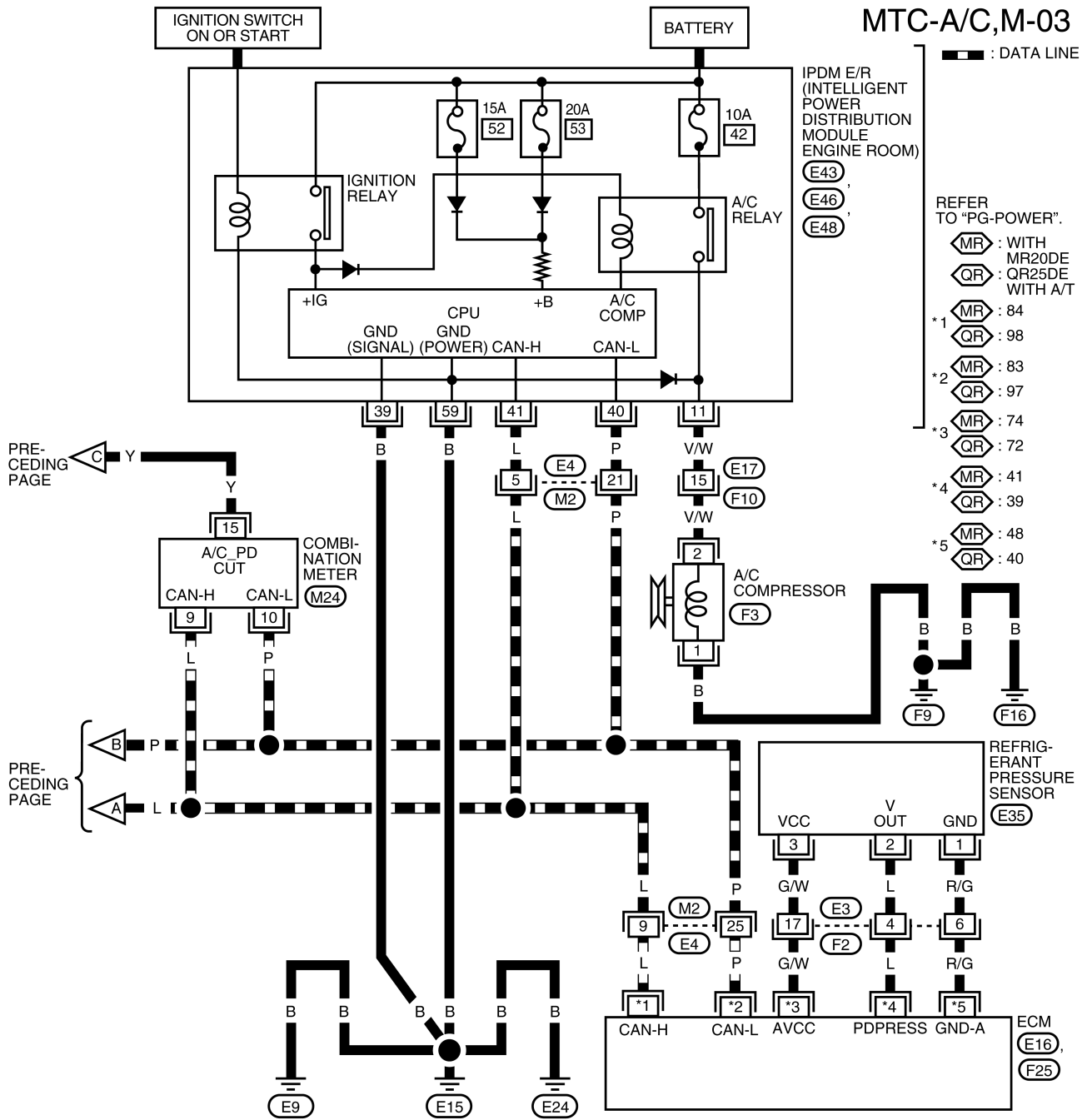

TROUBLE DIAGNOSIS

Front Air Control Terminals and Reference Values INSPECTION OF FRONT AIR CONTROL

EJS0050W

- Measure voltage between each terminal and body ground by following Terminals and Reference Value for front air control.

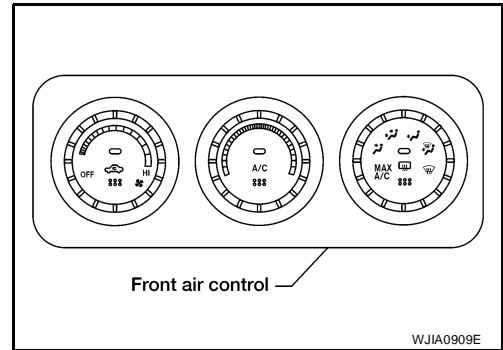

FRONT AIR CONTROL HARNESS CONNECTOR TERMINAL LAYOUT

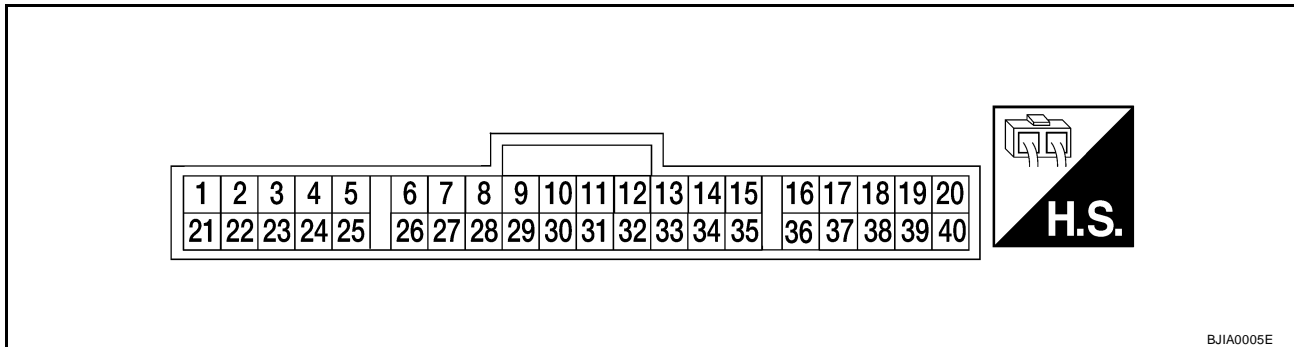

TERMINAL AND REFERENCE VALUES FOR FRONT AIR CONTROL

Terminal No.	Wire color	Item	Ignition switch	Condition	Voltage (V) (Approx.)	
1	W	Power supply for BAT	—	—	12	
2	BR	Power supply for IGN		—	12	
3	B	Ground			0	
18	P	A/C LAN signal (with A/C)		—	5.5	
19	Y	A/C PD Cut (with A/C)		—	5	
20	GR	Sensor ground		—	0	
21	Y	Power supply for IGN		—	12	
22	O	Power supply for mode door motor, intake door motor, and air mix door motor		—	12	
23	R	Light (+)		Lighting switch	OFF	0
24	V	Light (-)			1st position	12
36	R	Blower motor feed back		Fan speed	—	0
37	L	Fan control AMP. control signal	Low		7 - 10	
			Any speed except high		2.5 - 3	
38	L/G	Rear defrost ON signal		Defroster switch	High	9- 10
					ON	0
39	S/B	Fan ON signal		Fan	OFF	5
					ON	0
					5	

A
B
C
D
E
F
G
H
I

MTC

K
L
M

TROUBLE DIAGNOSIS

Terminal No.	Wire color	Item	Ignition switch	Condition		Voltage (V) (Approx.)
40	G	Compressor ON signal (with A/C)		Compressor	ON	0
					OFF	5

TROUBLE DIAGNOSIS

EJS0050X

Operational Check

The purpose of the operational check is to confirm that the system operates properly.

Conditions : Engine running at normal operating temperature

CHECKING BLOWER

1. Turn blower control dial clockwise, blower should operate on low speed.
2. Continue turning blower control dial clockwise, and continue checking blower speeds until all speeds are checked.
3. Leave blower on Maximum speed.



If NG, go to [MTC-56, "Blower Motor Circuit"](#) .

If OK, continue the check.

CHECKING DISCHARGE AIR

1. Turn mode door control dial to each position.
2. Confirm that discharge air comes out according to the air distribution table. Refer to [MTC-29, "Discharge Air Flow"](#) .

NOTE:



Confirm that the compressor clutch is engaged (audio or visual inspection) and intake door is in the fresh () position when the DEF  is selected.

Intake door position is checked in the next step.

If NG, go to [MTC-50, "Mode Door Motor Circuit"](#) , [MTC-85, "MODE DOOR MOTOR"](#) .

If OK, continue the check.

CHECKING RECIRCULATION

1. Press REC  switch.
Recirculation indicator should illuminate.
2. Press REC  switch a second time.
Recirculation indicator should turn off.
3. Listen for intake door position change (you should hear blower sound change slightly).

If NG, go to [MTC-54, "Intake Door Motor Circuit"](#) .

If OK, continue with the check.

CHECKING TEMPERATURE DECREASE

1. Turn temperature control dial counterclockwise to full cold position.
2. Check for cold air at discharge air outlets.

If NG, go to [MTC-66, "Insufficient Cooling"](#) .

If OK, continue the check.

CHECKING TEMPERATURE INCREASE

1. Turn temperature control dial clockwise to full hot position.
2. Check for hot air at discharge air outlets.

If NG, go to [MTC-74, "Insufficient Heating"](#) .

If OK, continue the check.

CHECKING A/C SWITCH (IF EQUIPPED)

1. Turn blower control dial to the desired position and push the air conditioner switch (if equipped) to turn ON the air conditioner.
2. Confirm that the A/C indicator lamp illuminates and that the compressor clutch engages (audio or visual inspection).

If NG, go to [MTC-44, "Power Supply and Ground Circuit for Front Air Control"](#) , then if necessary, [MTC-62, "Magnet Clutch Circuit"](#) .

If all operational checks are OK (symptom can not be duplicated), go to [GI-27, "How to Perform Efficient Diagnosis for an Electrical Incident"](#) and perform tests as outlined to simulate driving condition environment. If symptom appears, refer to [MTC-31, "SYMPTOM TABLE"](#) and perform applicable trouble diagnosis procedures.

A
B
C
D
E
F
G
H
I
K
L
M

MTC

TROUBLE DIAGNOSIS

EJS0050Y

Power Supply and Ground Circuit for Front Air Control

SYMPTOM:

- Heater and A/C system (if equipped) does not come on.

INSPECTION FLOW

1. CONFIRM SYMPTOM BY PERFORMING OPERATIONAL CHECK

1. Turn blower control dial to any speed.
2. Turn mode dial to vent () position, and press A/C switch (if equipped).
3. Confirm that the compressor clutch engages (sound or visual inspection).

Can a symptom be duplicated?

- YES >> GO TO 3.
NO >> GO TO 2.

2. PERFORM COMPLETE OPERATIONAL CHECK

Perform a complete operational check and check for any symptoms. Refer to [MTC-43, "Operational Check"](#) .

Can a symptom be duplicated?

- YES >> Refer to [MTC-31, "SYMPTOM TABLE"](#) .
NO >> System OK.

3. CHECK FOR SERVICE BULLETINS

Check for any service bulletins.

>> GO TO 4.

4. CHECK POWER AND GROUND CIRCUIT

Check main power supply and ground circuit. Refer to [MTC-44, "Power Supply and Ground Circuit for Front Air Control"](#) .

OK or NG

- OK >> System OK.
NO >> Replace front air control. Refer to [MTC-77, "FRONT AIR CONTROL"](#) .

TROUBLE DIAGNOSIS

COMPONENT DESCRIPTION

FRONT AIR CONTROL

The front air control has a built-in microcomputer which processes information sent from the temperature control dial, and various switches needed for air conditioner operation. The air mix door motor, mode door motor, intake door motor, blower motor and compressor are then controlled.

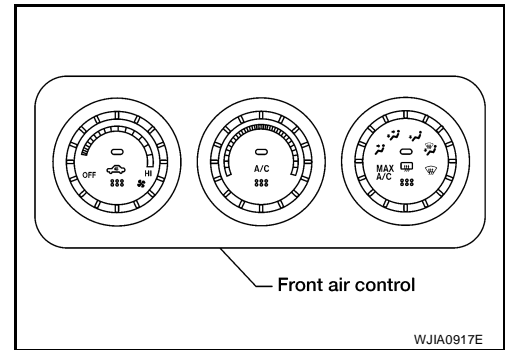

POTENTIAL TEMPERATURE CONTROL (PTC)

The PTC is built into the front air control.

DIAGNOSTIC PROCEDURE

SYMPTOM:

- Heater and A/C system (if equipped) does not come on.

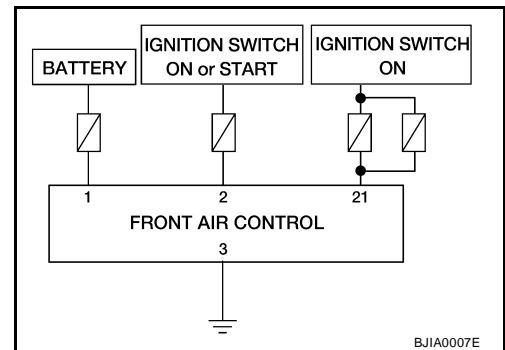

1. CHECK POWER SUPPLY CIRCUIT FOR FRONT AIR CONTROL

1. Disconnect front air control connector M33.
2. Turn ignition switch ON.
3. Check voltage between front air control connector M33 terminals 1, 2, and 21, and ground.

Terminals		Voltage (V) (Approx.)
(+)	(-)	
Connector - Terminal	Body ground	12V
M33-1		
M33-2		
M33-21		

OK or NG

OK >> GO TO 2.

NG >> Check the following.

- 10A fuse [Nos. 12 and 19, located in the fuse block (J/B)] and 15A fuses [Nos. 10 and 11, located in the fuse block (J/B)].
- If fuses are OK, check for open circuit in wiring harness. Repair or replace as necessary.
- If fuses are NG, replace fuse and check wiring harness for short circuit. Repair or replace as necessary.

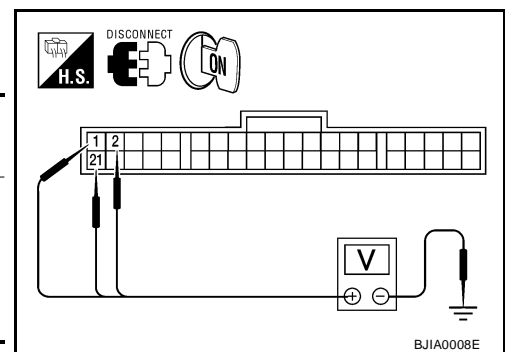

TROUBLE DIAGNOSIS

2. CHECK BODY GROUND CIRCUIT FOR FRONT AIR CONTROL

1. Turn ignition switch OFF.
2. Check continuity between front air control connector M33 terminal 3 and ground.

Terminal		Continuity
(+)	(-)	
Connector - Terminal	Body ground	Yes
M33-3		

OK or NG

- OK >> ● Replace front air control. Refer to [MTC-77, "FRONT AIR CONTROL"](#) .
- Inspection End.
- NG >> Repair or replace harness.

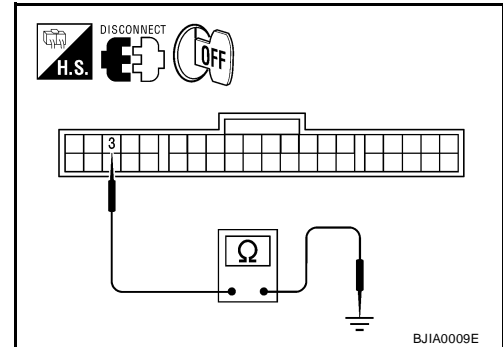

TROUBLE DIAGNOSIS

EJS0050Z

LAN System Circuit

SYMPTOM: Mode door motor, intake door motor and/or air mix door motor do not operate normally.

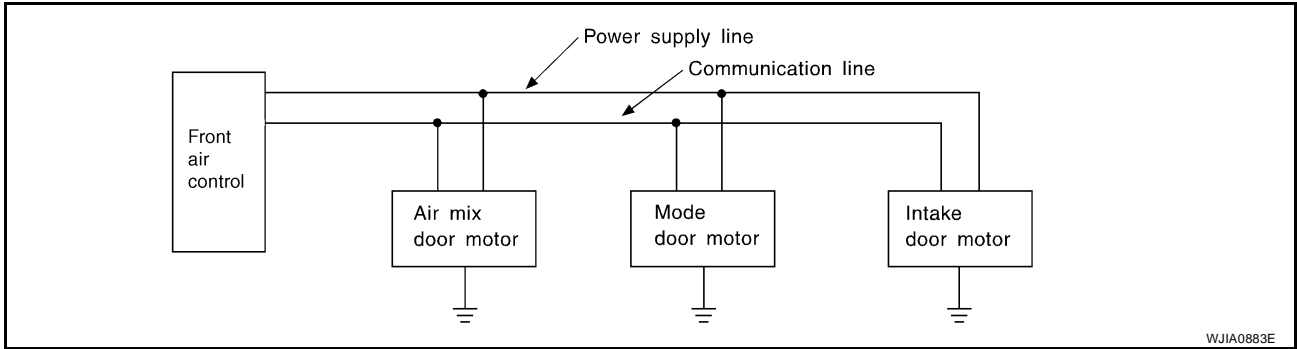

DIAGNOSTIC PROCEDURE

1. CHECK POWER SUPPLY FOR DOOR MOTORS

1. Turn ignition switch ON.
2. Check voltage between front air control connector M33 terminal 22 and ground.

Terminals		Voltage (V) (Approx.)
(+)	(-)	
Connector		
M33-22	Body ground	12V

OK or NG

OK >> GO TO 2.

NG >> Replace front air control. Refer to [MTC-77, "FRONT AIR CONTROL"](#).

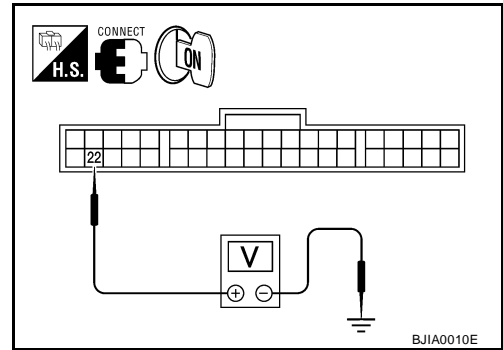

2. CHECK SIGNAL FOR DOOR MOTORS

Check voltage between front air control connector M33 terminal 18 and ground.

Terminals		Voltage (V) (Approx.)
(+)	(-)	
Connector		
M33-18	Ground	5.5V

OK or NG

OK >> GO TO 3.

NG >> Replace front air control. Refer to [MTC-77, "FRONT AIR CONTROL"](#).

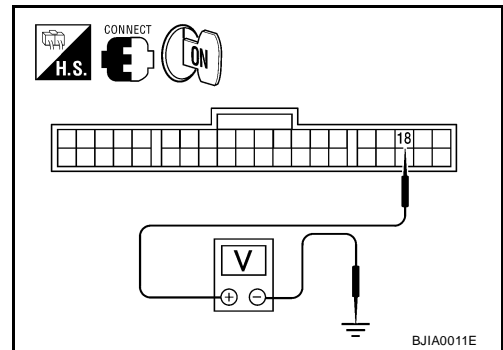

TROUBLE DIAGNOSIS

3. CHECK POWER SUPPLY FOR MOTOR

Check voltage between mode door motor connector M51 terminal 1 and ground, between air mix door motor connector M34 terminal 1 and ground, and between intake door motor connector M48 terminal 1 and ground.

Door motors	Terminals		Voltage (V) (Approx.)
	(+)	(-)	
	Connector		
Mode	M51-1	Body ground	12V
Air mix	M34-1		
Intake	M48-1		

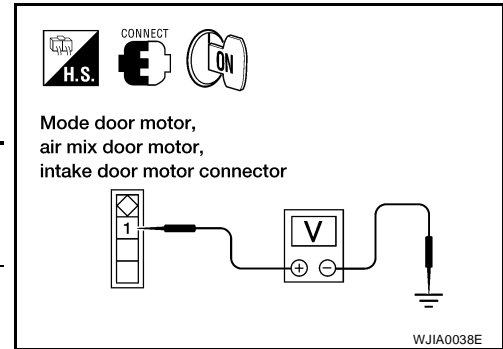

OK or NG

- OK >> GO TO 4.
- NG >> Replace harness or connector.

4. CHECK SIGNAL FOR MOTOR

Check voltage between mode door motor connector M51 terminal 3 and ground, between air mix door motor connector M34 terminal 3 and ground, and between intake door motor connector M48 terminal 3 and ground.

Door motors	Terminals		Voltage (V) (Approx.)
	(+)	(-)	
	Connectors		
Mode	M51-3	Body ground	5.5V
Air mix	M34-3		
Intake	M48-3		

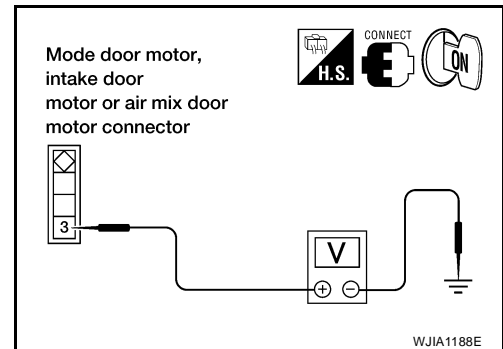

OK or NG

- OK >> GO TO 5.
- NG >> Replace harness or connector.

5. CHECK MOTOR GROUND CIRCUIT

1. Turn ignition switch OFF.
2. Disconnect door motor connectors.
3. Check continuity between mode door motor connector M51 terminal 2 and ground, between air mix door motor connector M34 terminal 2 and ground, and between intake door motor connector M48 terminal 2 and ground.

Door motors	Terminals		Continuity
	(+)	(-)	
	Connector		
Mode	M51-2	Body ground	Yes
Air mix	M34-2		
Intake	M48-2		

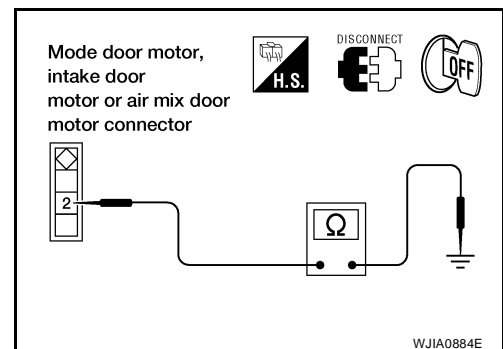

OK or NG

- OK >> GO TO 6.
- NG >> Replace harness or connector.

TROUBLE DIAGNOSIS

6. CHECK MOTOR OPERATION

Disconnect and reconnect the motor connectors and confirm the motor operation.

OK or NG

- OK >> (Returns to normal operation.)
- Motor connector contacts dirty or damaged
- NG >> (Does not operate normally.)
- GO TO 7.

7. CHECK MODE DOOR MOTOR AND AIR MIX DOOR MOTOR OPERATION

1. Disconnect the intake door motor connector.
2. Reconnect the mode door motor connector and air mix door motor connector, confirm the mode door motor and air mix door motor operation.

OK or NG

- OK >> (Mode door motor and air mix door motor operate normally.)
- Replace the intake door motor. Refer to [MTC-84, "Removal and Installation"](#) .
- NG >> (Mode door motor and air mix door motor do not operate normally.)
- GO TO 8.

8. CHECK AIR MIX DOOR MOTOR AND INTAKE DOOR MOTOR OPERATION

1. Disconnect mode door motor connector.
2. Reconnect the intake door motor connector, confirm the air mix door motor and intake door motor operation.

OK or NG

- OK >> (Air mix door motor and intake door motor operate normally.)
- Replace mode door motor. Refer to [MTC-85, "Removal and Installation"](#) .
- NG >> (Air mix door motor and intake door motor do not operate normally.)
- GO TO 9.

9. CHECK INTAKE DOOR MOTOR AND MODE DOOR MOTOR OPERATION

1. Disconnect air mix door motor connector.
2. Reconnect mode door motor connector, confirm the intake door motor and mode door motor operation.

OK or NG

- OK >> (Intake door motor and mode door motor operate normally.)
- Replace air mix door motor. Refer to [MTC-86, "AIR MIX DOOR MOTOR"](#) .
- NG >> (Intake door motor and mode door motor do not operate normally.)
- Replace front air control. Refer to [MTC-77, "FRONT AIR CONTROL"](#) .

TROUBLE DIAGNOSIS

EJS005P0

Mode Door Motor Circuit

SYMPTOM:

- Air outlet does not change.
- Mode door motor does not operate normally.

INSPECTION FLOW

1. CONFIRM SYMPTOM BY PERFORMING OPERATIONAL CHECK - DISCHARGE AIR

1. Turn mode dial to all five positions.
2. Confirm that discharge air comes out according to the air distribution table. Refer to [MTC-29, "Discharge Air Flow"](#).

Can a symptom be duplicated?

- YES >> GO TO 3.
NO >> GO TO 2.

2. PERFORM COMPLETE OPERATIONAL CHECK

Perform a complete operational check and check for any symptoms. Refer to [MTC-43, "Operational Check"](#).

Can a symptom be duplicated?

- YES >> Refer to [MTC-31, "SYMPTOM TABLE"](#).
NO >> System OK.

3. CHECK FOR SERVICE BULLETINS

Check for any service bulletins.

>> GO TO 4.

4. CHECK MODE DOOR OPERATION

Check and verify mode door mechanism for smooth operation in each mode.

OK or NG

- OK >> GO TO 5.
NG >> Repair as necessary.

5. CHECK LAN SYSTEM CIRCUIT

Perform diagnostic procedure for the LAN system. Refer to [MTC-47, "LAN System Circuit"](#).

OK or NG

- OK >> If the symptom still exists, perform a complete operational check. Refer to [MTC-43, "Operational Check"](#). If no other symptom exists replace front air control. Refer to [MTC-77, "Removal and Installation"](#).
NG >> Repair as necessary.

TROUBLE DIAGNOSIS

SYSTEM DESCRIPTION

Component Parts

Mode door control system components are:

- Front air control
- Mode door motor (LCU)

System Operation

The front air control receives signals from its various dials and switches. The front air control then sends air mix door, mode door and intake door motor opening angle data to the air mix door motor LCU, mode door motor LCU and intake door motor LCU.

The mode door motor reads their respective signals according to the address signal. Opening angle indication signals received from the front air control and each of the motor position sensors are compared by the LCU's in each motor with the existing decision and opening angles. Subsequently, HOT/COLD or DEFROST/VENT or FRESH/RECIRCULATION operation is selected. The new selection data is returned to the front air control.

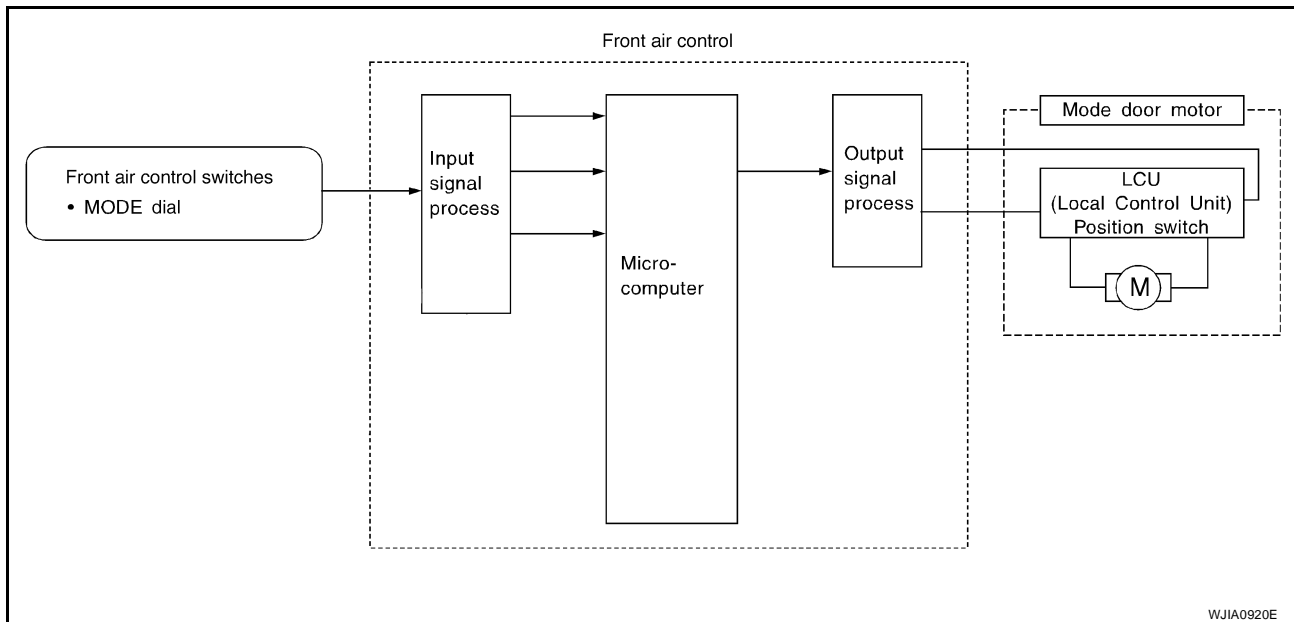

COMPONENT DESCRIPTION

Mode Door Motor

The mode door motor (1) is attached to the heater and cooling unit assembly. It rotates so that air is discharged from the outlet set by the front air control. Motor rotation is conveyed to a link which activates the mode door.

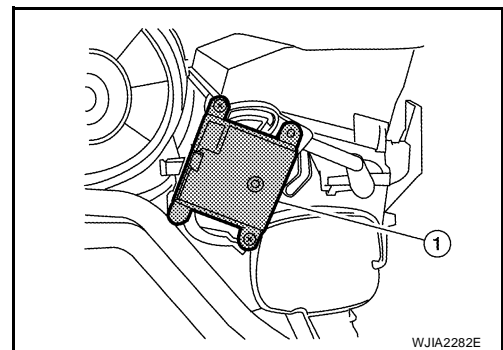

DIAGNOSTIC PROCEDURE

SYMPTOM: Mode door motor and/or air mix door motor does not operate normally.

Perform diagnostic procedure for LAN system circuit. Refer to [MTC-47, "LAN System Circuit"](#).

A
B
C
D
E
F
G
H
I

MTC

K
L
M

TROUBLE DIAGNOSIS

EJS005P1

Air Mix Door Motor Circuit

SYMPTOM:

- Discharge air temperature does not change.
- Air mix door motor does not operate.

INSPECTION FLOW

1. CONFIRM SYMPTOM BY PERFORMING OPERATIONAL CHECK - TEMPERATURE INCREASE

1. Turn the temperature control dial clockwise.
2. Check for hot air at discharge air outlets.

>> GO TO 2.

2. CONFIRM SYMPTOM BY PERFORMING OPERATIONAL CHECK - TEMPERATURE DECREASE

1. Turn the temperature control dial counterclockwise.
2. Check for cold air at discharge air outlets.

Can a symptom be duplicated?

YES >> GO TO 4.

NO >> GO TO 3.

3. PERFORM COMPLETE OPERATIONAL CHECK

Perform a complete operational check and check for any symptoms. Refer to [MTC-43, "Operational Check"](#) .

Can a symptom be duplicated?

YES >> Refer to [MTC-31, "SYMPTOM TABLE"](#) .

NO >> System OK.

4. CHECK FOR SERVICE BULLETINS

Check for any service bulletins.

>> GO TO 5.

5. CHECK AIR MIX DOOR OPERATION

Check and verify air mix door mechanism for smooth operation in each mode.

OK or NG

OK >> GO TO 6.

NG >> Repair as necessary.

6. CHECK LAN SYSTEM CIRCUIT

Perform diagnostic procedure for the LAN system. Refer to [MTC-47, "LAN System Circuit"](#) .

OK or NG

OK >> If the symptom still exists, perform a complete operational check. Refer to [MTC-43, "Operational Check"](#) . If no other symptom exists replace front air control. Refer to [MTC-77, "Removal and Installation"](#) .

NG >> Repair as necessary.

TROUBLE DIAGNOSIS

SYSTEM DESCRIPTION

Component Parts

Air mix door control system components are:

- Front air control
- Air mix door motor (LCU)

System Operation

The front air control receives signals from its various dials and switches. The front air control then sends air mix door, mode door and intake door motor opening angle data to the air mix door motor LCU, mode door motor LCU and intake door motor LCU.

The air mix door motor, mode door motor and intake door motor read their respective signals according to the address signal. Opening angle indication signals received from the front air control and each of the motor position sensors are compared by the LCUs in each motor with the existing decision and opening angles. Subsequently, HOT/COLD or DEFROST/VENT or FRESH/RECIRCULATION operation is selected. The new selection data is returned to the front air control.

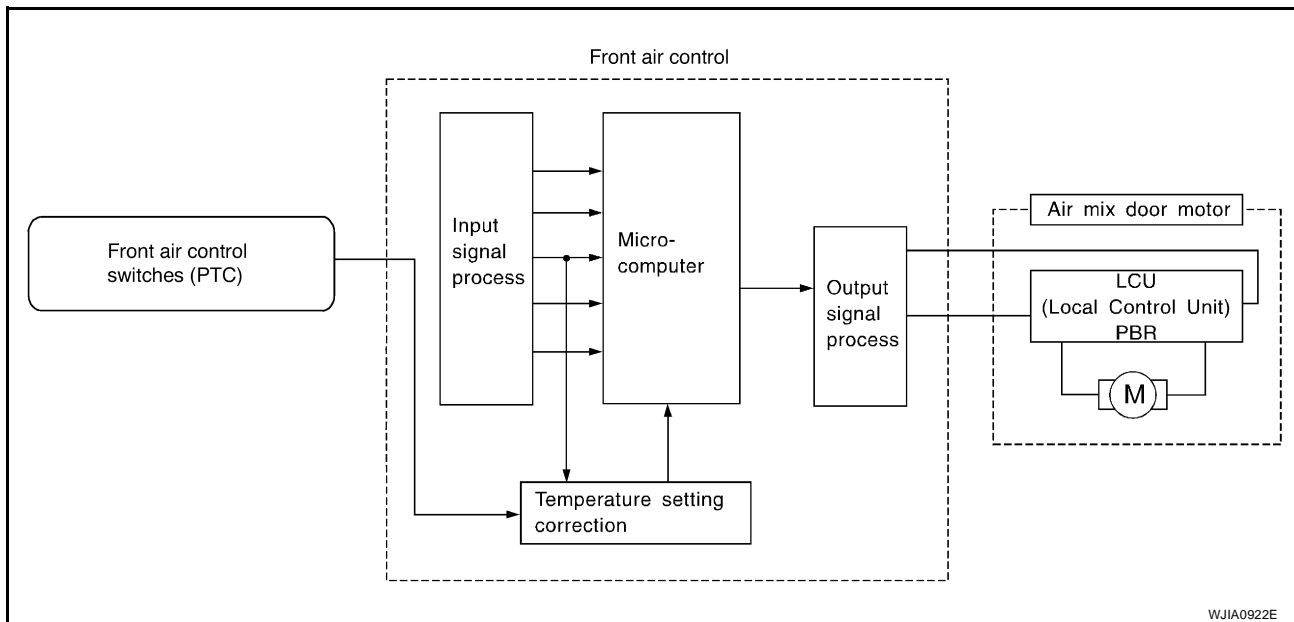

COMPONENT DESCRIPTION

Air Mix Door Motor

The air mix door motor (1) is attached to the heater and cooling unit assembly. It rotates so that the air mix door is opened or closed to a position set by the front air control. Motor rotation is then conveyed through a shaft and the air mix door position is then fed back to the front air control by PBR built-in air mix door motor.

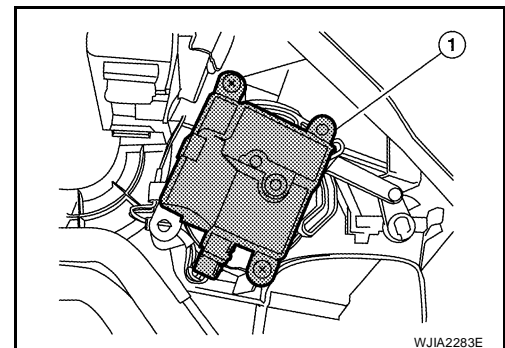

DIAGNOSTIC PROCEDURE

SYMPTOM: Discharge air temperature does not change.

Perform diagnostic procedure for LAN system circuit. Refer to [MTC-47, "LAN System Circuit"](#).

TROUBLE DIAGNOSIS

EJS005P2



Intake Door Motor Circuit

SYMPTOM:

- Intake door does not change.
- Intake door motor does not operate normally.

INSPECTION FLOW

1. CONFIRM SYMPTOM BY PERFORMING OPERATIONAL CHECK - REC ()

1. Press REC () switch. Recirculation indicator should illuminate.
2. Press REC () switch again. The REC () indicator should go out.
3. Listen for intake door position change (blower sound should change slightly).

Can a symptom be duplicated?

- YES >> GO TO 3.
NO >> GO TO 2.

2. PERFORM COMPLETE OPERATIONAL CHECK

Perform a complete operational check and check for any symptoms. Refer to [MTC-43, "Operational Check"](#) .

Can a symptom be duplicated?

- YES >> Refer to [MTC-31, "SYMPTOM TABLE"](#) .
NO >> System OK.

3. CHECK FOR SERVICE BULLETINS

Check for any service bulletins.

>> GO TO 4.

4. CHECK INTAKE DOOR OPERATION

Check and verify intake door mechanism for smooth operation in each mode.

OK or NG

- OK >> GO TO 5.
NG >> Repair as necessary.

5. CHECK LAN SYSTEM CIRCUIT

Perform diagnostic procedure for the LAN system. Refer to [MTC-47, "LAN System Circuit"](#) .

OK or NG

- OK >> If the symptom still exists, perform a complete operational check. Refer to [MTC-43, "Operational Check"](#) . If no other symptom exists replace front air control. Refer to [MTC-77, "Removal and Installation"](#) .
NG >> Repair as necessary.

TROUBLE DIAGNOSIS

SYSTEM DESCRIPTION

Component Parts

Intake door control system components are:

- Front air control
- Intake door motor

System Operation

The intake door control determines intake door position based on the position of the recirculation switch. When the front air control is set to DEFROST, or OFF, the front air control sets the intake door at the fresh position.

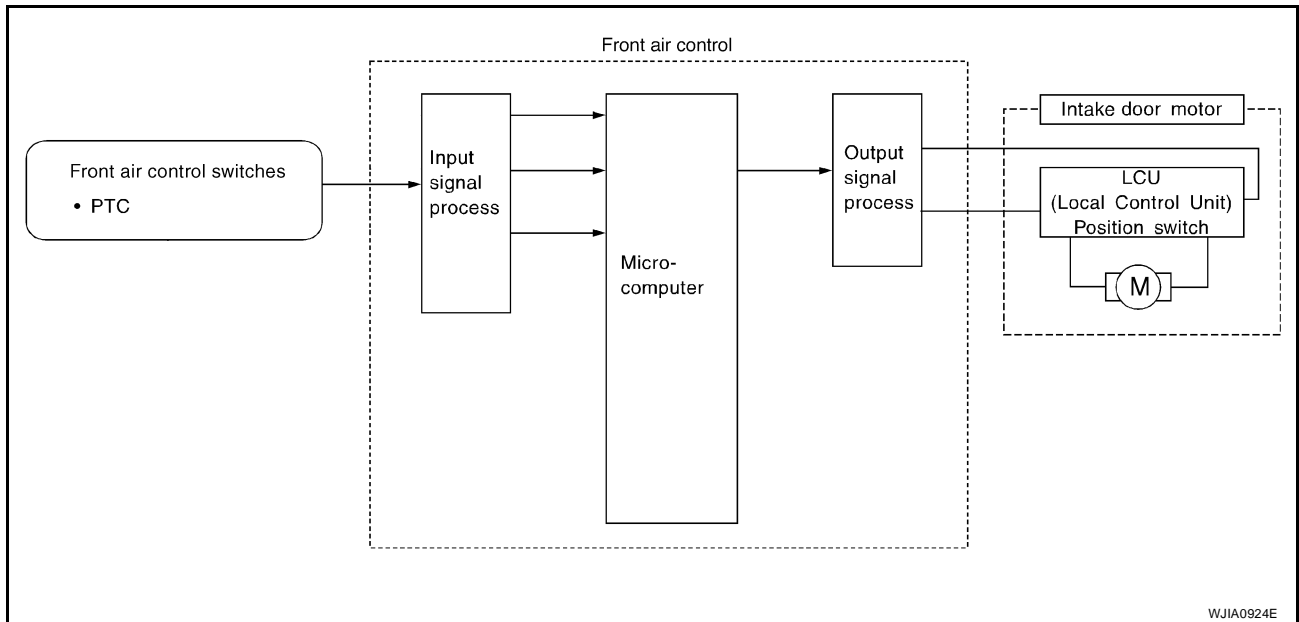

COMPONENT DESCRIPTION

Intake door motor

The intake door motor (1) is attached to the intake unit. It rotates so that air is drawn from inlets set by the front air control. Motor rotation is conveyed to a lever which activates the intake door. Door position is then fed back to the front air control by PBR built-in air mix door motor.

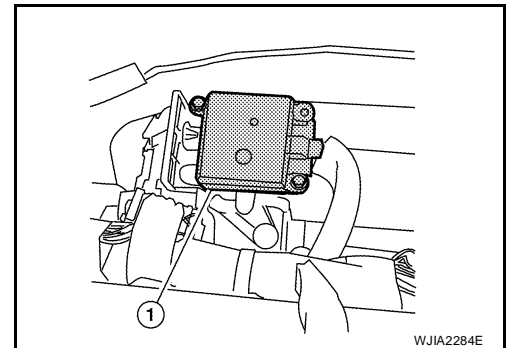

DIAGNOSTIC PROCEDURE

SYMPTOM: Intake door motor does not operate normally.

Perform diagnostic procedure for LAN system circuit. Refer to [MTC-47, "LAN System Circuit"](#).

A
B
C
D
E
F
G
H
I

MTC

K
L
M

TROUBLE DIAGNOSIS

EJS005P3

Blower Motor Circuit

SYMPTOM:

- Blower motor operation is malfunctioning.

INSPECTION FLOW

1. CONFIRM SYMPTOM BY PERFORMING OPERATIONAL CHECK - FRONT BLOWER

1. Turn blower control dial clockwise one detent. Blower should operate on low speed.
2. Continue checking blower speed until all speeds are checked.
3. Leave blower on HI speed.

Can the symptom be duplicated?

- YES >> GO TO 3.
NO >> GO TO 2.

2. PERFORM COMPLETE OPERATIONAL CHECK

Perform a complete operational check and check for any symptoms. Refer to [MTC-43, "Operational Check"](#) .

Can a symptom be duplicated?

- YES >> Refer to [MTC-31, "SYMPTOM TABLE"](#) .
NO >> System OK.

3. CHECK FOR SERVICE BULLETINS

Check for any service bulletins.

>> GO TO 4.

4. CHECK BLOWER MOTOR CIRCUIT

Perform diagnostic procedure for the blower motor circuit. Refer to [MTC-58, "DIAGNOSTIC PROCEDURE"](#) .

OK or NG

- OK >> If the symptom still exists, perform a complete operational check and check for other symptoms. Refer to [MTC-43, "Operational Check"](#) . and check for other symptoms. Refer to [MTC-31, "SYMPTOM TABLE"](#) . If no other symptom exists replace front air control. Refer to [MTC-77, "Removal and Installation"](#) .
- NG >> Repair as necessary.

TROUBLE DIAGNOSIS

SYSTEM DESCRIPTION

Component Parts

Fan speed control system components are:

- Front air control
- LAN system (PBR built-in mode door motor, air mix door motor and intake door motor)
- Blower motor
- Fan control amplifier

System Operation

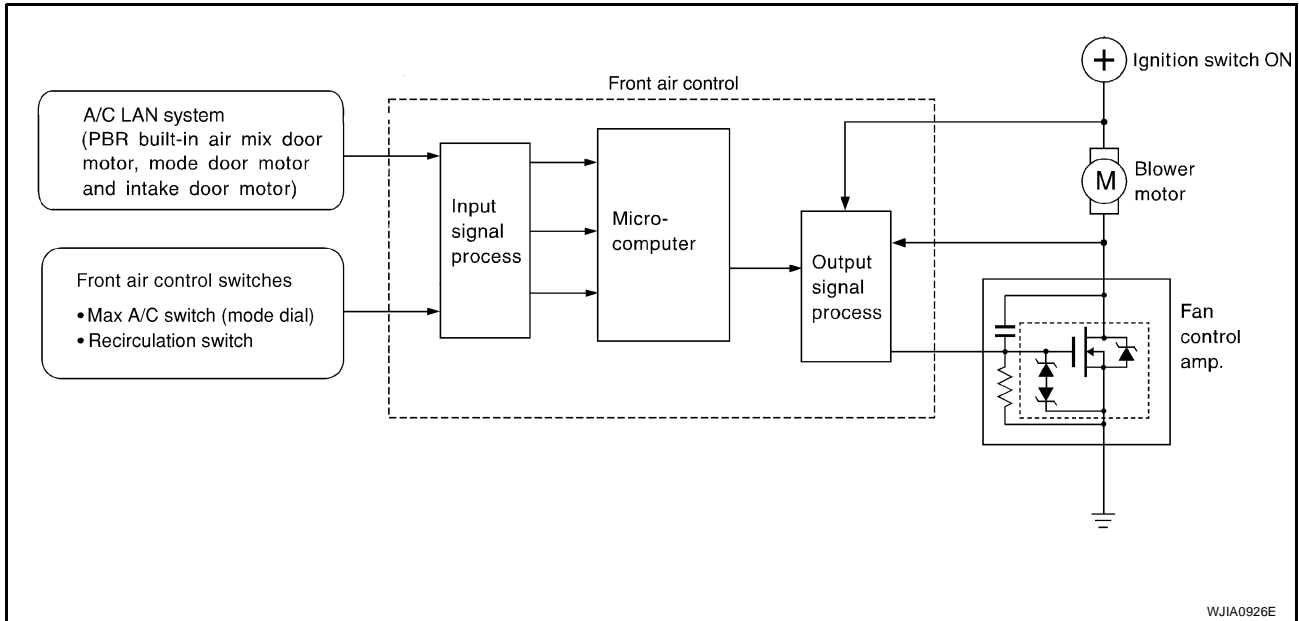

COMPONENT DESCRIPTION

Fan Control Amplifier

The fan control amplifier (1) is located on the cooling unit. The fan control amp. receives a gate voltage from the front air control to smoothly maintain the blower fan motor voltage in the 5 to the 12V range (approx.).

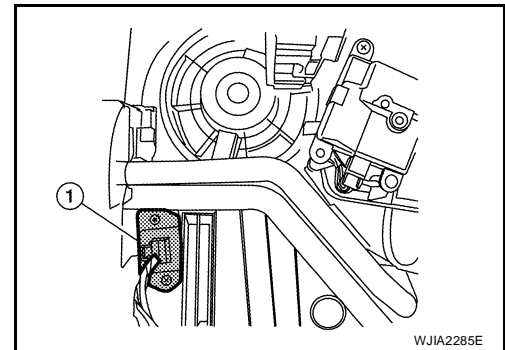

A
B
C
D
E
F
G
H
I

MTC

K
L
M

TROUBLE DIAGNOSIS

DIAGNOSTIC PROCEDURE

SYMPTOM: Blower motor is malfunctioning.

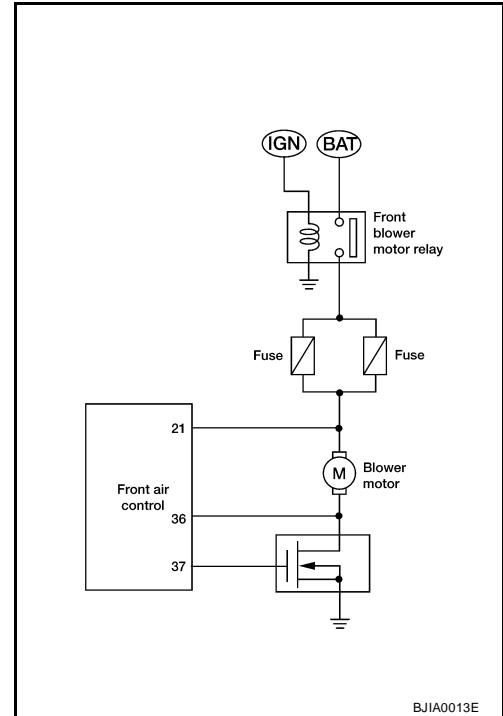

BJIA0013E

1. CHECK POWER SUPPLY FOR FAN CONTROL AMP.

1. Disconnect fan control amp. connector.
2. Turn ignition switch ON.
3. Check voltage between fan control amp. harness connector M52 terminal 3 and ground.

Terminal		Voltage (V) (Approx.)
(+)	(-)	
Connector - Terminal		
M52-3	Body ground	12V

OK or NG

- OK >> GO TO 2.
NG >> GO TO 7.

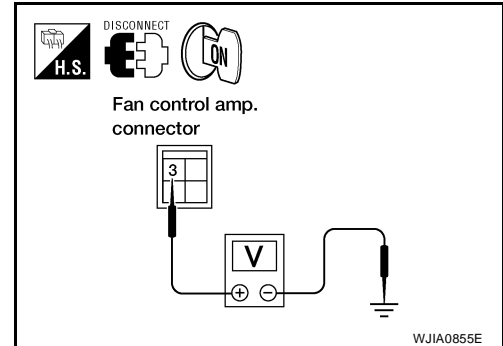

WJIA0855E

2. CHECK FAN FEEDBACK CIRCUIT

1. Disconnect front air control connector.
2. Check voltage between front air control harness connector M33 terminal 36 and ground.

Terminal		Voltage (V) (Approx.)
(+)	(-)	
Connector - Terminal		
M33-18	Body ground	12V

OK or NG

- OK >> GO TO 3.
NG >> Check for open circuit in wiring harness. Repair or replace as necessary.

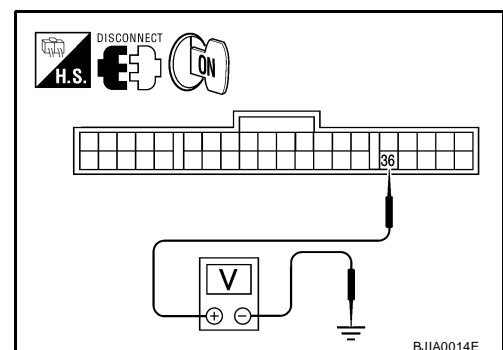

BJIA0014E

TROUBLE DIAGNOSIS

3. CHECK BODY GROUND CIRCUIT FOR FAN CONTROL AMP.

1. Turn ignition switch OFF.
2. Check continuity between fan control amp. harness connector M52 terminal 1 and ground.

Terminal		Continuity
Connector - Terminal	Body ground	Yes
M52-1		

OK or NG

- OK >> Reconnect fan control amp. harness connector and GO TO 4.
- NG >> Repair harness or connector.

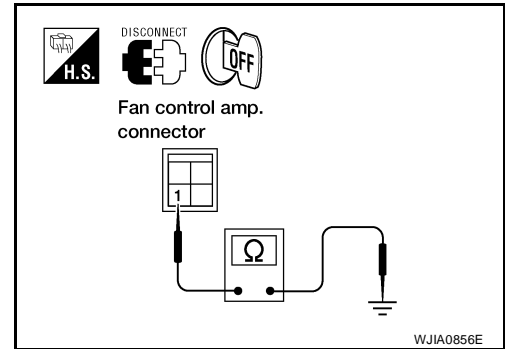

4. CHECK VOLTAGE FOR FAN CONTROL AMP.

1. Turn ignition switch ON.
2. Turn blower control dial to any position except OFF or AUTO.
3. Check voltage between fan control amp. harness connector M52 terminal 2 and ground.

Terminal		Voltage (V) (Approx.)
(+)	(-)	
Connector - Terminal	Body ground	12V
M52-2		

OK or NG

- OK >> 1. Replace fan control amp. Refer to [MTC-87, "Removal and Installation"](#).
2. Confirm that blower motor operation is normal.
- NG >> GO TO 5.

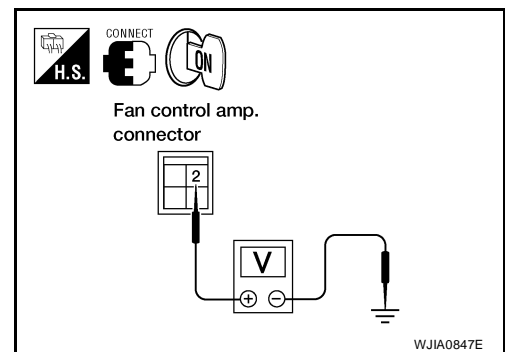

5. CHECK FAN CONTROL AMP. CIRCUIT BETWEEN FAN CONTROL AMP. AND FRONT AIR CONTROL

1. Turn ignition switch OFF.
2. Disconnect front air control and fan control amp. harness connectors.
3. Check continuity between fan control amp. harness connector M52 (A) terminal 2 and front air control harness connector M33 (B) terminal 37.

Terminals		Continuity
Connector - Terminal	Connector - Terminal	Yes
M52-2	M33-37	

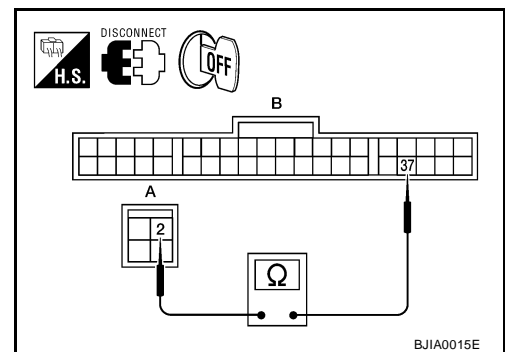

If OK, check harness for short.

OK or NG

- OK >> GO TO 6.
- NG >> Repair harness or connector.

TROUBLE DIAGNOSIS

6. CHECK POWER SUPPLY FOR FRONT AIR CONTROL

1. Turn ignition switch ON.
2. Check voltage between front air control harness connector M33 terminal 1 and ground.

Terminal		Voltage (V) (Approx.)
(+)	(-)	
Connector - Terminal	Body ground	12V
M33-1		

OK or NG

- OK >> 1. Replace front air control. Refer to [MTC-77, "FRONT AIR CONTROL"](#) .
2. Confirm that blower motor operation is normal.
- NG >> ● Check for open circuit in wiring harness.
Repair or replace as necessary.
- If OK, replace fuse and check wiring harness for short circuit.
Repair or replace an necessary.

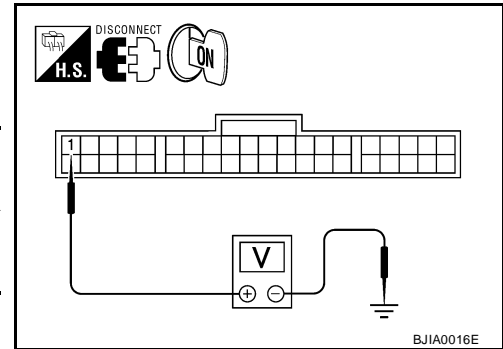

7. CHECK POWER SUPPLY FOR BLOWER MOTOR

1. Turn ignition OFF.
2. Disconnect blower motor harness connector.
3. Turn ignition switch ON.
4. Check voltage between blower motor harness connector M62 terminal 1 and ground.

Terminal		Voltage (V) (Approx.)
(+)	(-)	
Connector - Terminal	Body ground	12V
M62-1		

OK or NG

- OK >> GO TO 8.
- NG >> Check power supply circuit and 15A fuses [Nos. 10 and 11, located in the fuse block (J/B)].
- Check blower motor relay. Refer to [PG-13, "IGNITION POWER SUPPLY — IGNITION SWITCH IN ON"](#) .
Repair or replace as necessary.
- If OK, check for open circuit in wiring harness.
Repair or replace as necessary.
- If OK, replace fuse and check wiring harness for short circuit.
Repair or replace as necessary.

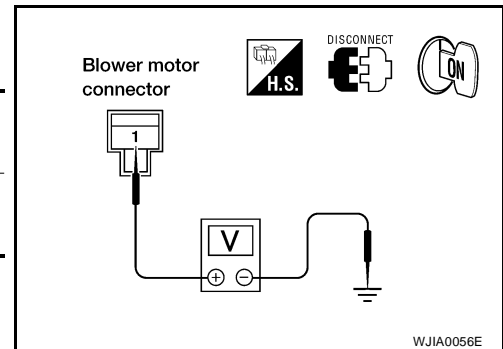

TROUBLE DIAGNOSIS

8. CHECK CIRCUIT CONTINUITY BETWEEN BLOWER MOTOR AND FAN CONTROL AMP.

1. Turn ignition switch OFF.
2. Disconnect front air control connector.
3. Check continuity between blower motor harness connector M62 terminal 2 and fan control amp. harness connector M52 terminal 3.

Terminals		Continuity
Connector - Terminal	Connector - Terminal	
M62-2	M52-3	Yes

OK or NG

- OK >> Check blower motor. Refer to [MTC-78, "FRONT BLOWER MOTOR"](#) .
1. If NG, replace blower motor. Refer to [MTC-78, "FRONT BLOWER MOTOR"](#) .
 2. Confirm that blower motor operation is normal.
- NG >> Repair harness or connector.

COMPONENT INSPECTION

Blower Motor

Confirm smooth rotation of the blower motor (1).

- Ensure that there are no foreign particles inside the intake unit.

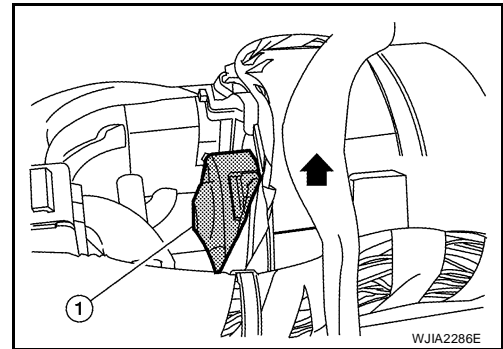
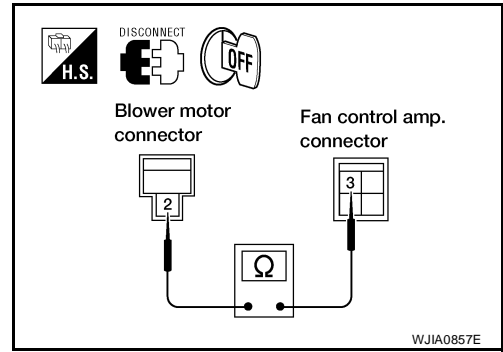

A
B
C
D
E
F
G
H
I
MTC
K
L
M

TROUBLE DIAGNOSIS

EJS005P4

Magnet Clutch Circuit

SYMPTOM: Magnet clutch does not engage.

INSPECTION FLOW

1. CONFIRM SYMPTOM BY PERFORMING OPERATIONAL CHECK - MAGNET CLUTCH

1. Turn ignition switch ON.
2. Turn blower control dial to the desired position.
3. Press the A/C switch. A/C indicator will turn on.
4. Confirm that the compressor clutch engages (sound or visual inspection).

Can the symptom be duplicated?

- YES >> GO TO 3.
NO >> GO TO 2.

2. CHECK FOR ANY SYMPTOMS

Perform a complete operational check for any symptoms. Refer to [MTC-43, "Operational Check"](#) .

Does another symptom exist?

- YES >> Refer to [MTC-31, "SYMPTOM TABLE"](#) .
NO >> System OK.

3. CHECK FOR SERVICE BULLETINS

Check for any service bulletins.

>> GO TO 4.

4. CHECK COMPRESSOR BELT TENSION

Check compressor belt tension. Refer to [EM-15, "Checking Drive Belts"](#) .

OK or NG

- OK >> GO TO 5.
NG >> Adjust or replace A/C compressor belt.

5. CHECK REFRIGERANT PRESSURE

Check refrigerant pressure with manifold gauge connected. Refer to [MTC-70, "Test Reading"](#) .

OK or NG

- OK >> GO TO 6.
NG >> Perform trouble diagnosis for unusual pressure. Refer to [MTC-70, "TROUBLE DIAGNOSIS FOR ABNORMAL PRESSURE"](#) .

6. CHECK MAGNET CLUTCH CIRCUIT

Perform diagnostic procedure for the magnetic clutch. Refer to [MTC-63, "DIAGNOSTIC PROCEDURE"](#) .

OK or NG

- OK >> If the symptom still exists, perform a complete operational check. Refer to [MTC-43, "Operational Check"](#) . If other symptoms exist, refer to [MTC-31, "SYMPTOM TABLE"](#) .
NG >> Repair as necessary.

TROUBLE DIAGNOSIS

SYSTEM DESCRIPTION

Front air control controls compressor operation by a signal from ECM.

DIAGNOSTIC PROCEDURE

SYMPTOM: Magnet clutch does not engage when A/C switch is ON.

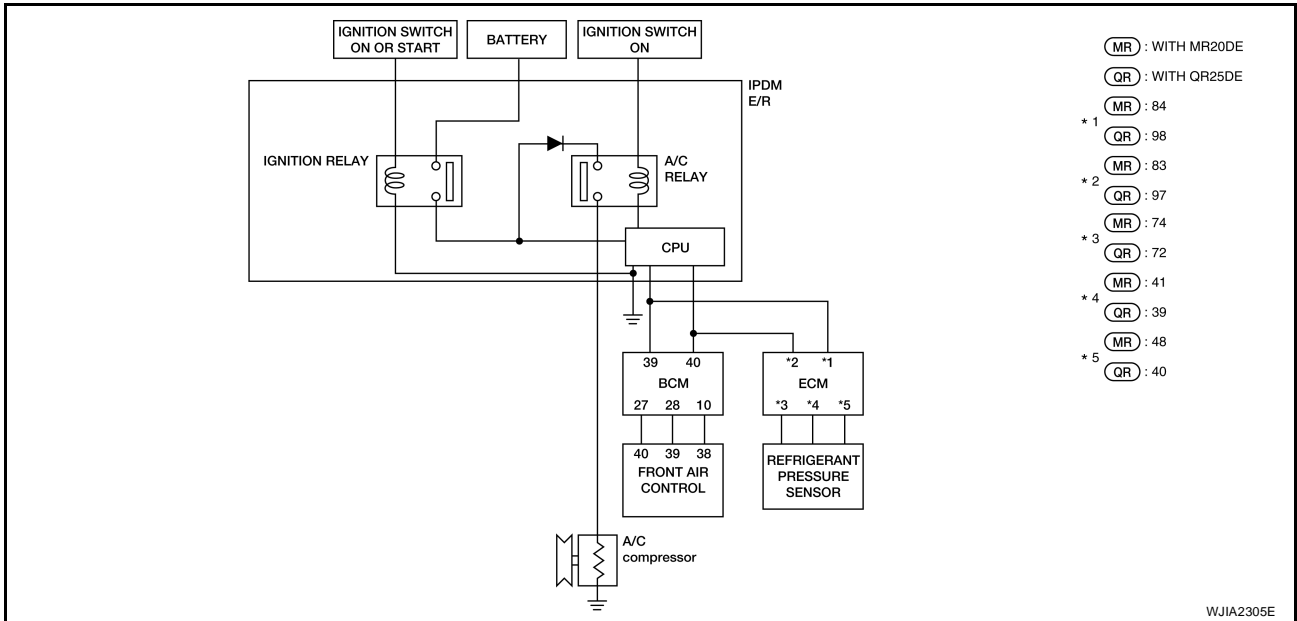

1. CHECK CIRCUIT CONTINUITY BETWEEN A/C RELAY IN IPDM E/R AND COMPRESSOR

1. Disconnect IPDM E/R connector E43 and compressor connector.
2. Check continuity between A/C compressor harness connector F3 terminal 2 and IPDM E/R harness connector E43 terminal 11.

Terminals		Continuity
Connector - Terminal	Connector - Terminal	Yes
F3 (A) - 2	E43 (B) - 11	

If OK, check harness for short to ground.

OK or NG

- OK >> GO TO 2.
- NG >> Repair harness or connector.

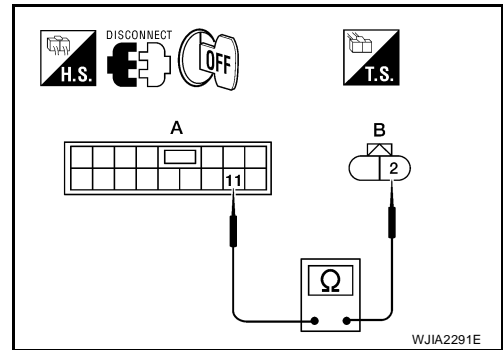

TROUBLE DIAGNOSIS

2. CHECK POWER SUPPLY FOR COMPRESSOR

1. Reconnect IPDM E/R harness connectors.
2. Start engine and press A/C switch.
3. Check voltage between A/C compressor harness connector F3 terminal 2 and ground.

Terminal		Voltage (V) (Approx.)
(+)	(-)	
Connector - Terminal	Body ground	12V
F3-2		

OK or NG

OK >> Check magnet clutch coil.

1. If NG, replace magnet clutch. Refer to [MTC-99, "Removal and Installation for Compressor Clutch - MR20DE"](#) .
2. If OK, check A/C compressor mounting points for looseness or corrosion and repair as necessary.

NG >> GO TO 3.

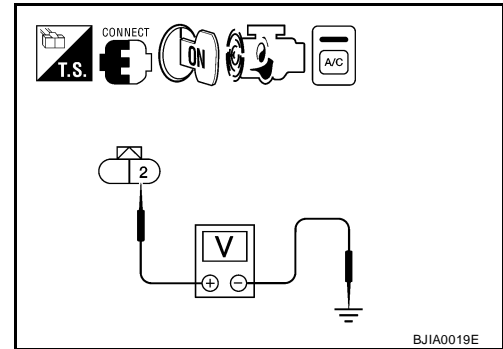

3. CHECK FUSE IN IPDM E/R

Check 10A fuse [No. 42 located at the IPDM E/R].

OK or NG

OK >> GO TO 4.

NG >> Replace fuse and check IPDM E/R for short circuit. Replace if necessary.

4. CHECK CONTINUITY BETWEEN BCM AND FRONT AIR CONTROL

1. Disconnect BCM connector M18 and front air control connector M33.
2. Check continuity between BCM harness connector M18 (A) terminals 27, 28 and front air control connector M33 (B) terminals 40, 39.

Terminals		Continuity
Connector - Terminal	Connector - Terminal	
M18 (A) - 27	M33 (B) - 40	Yes
M18 (A) - 28	M33 (B) - 39	

OK or NG

OK >> GO TO 5.

NG >> Repair harness or connector.

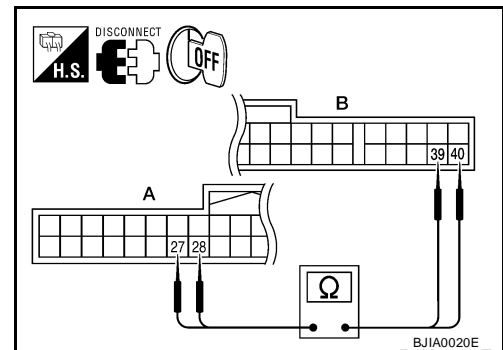

TROUBLE DIAGNOSIS

5. CHECK REFRIGERANT PRESSURE SENSOR INPUT SIGNAL

Check voltage between ECM harness connector F25 terminal 41 [*1(with MR20DE)], 39 [*2 with QR25DE]] and ground.

Terminal		Voltage (V) (Approx.)
(+)	(-)	
Connector - Terminal	Body ground	12V
F25 - 41 with MR20DE F25 - 39 with QR25DE		

OK or NG

- OK >> GO TO 6.
- NG >> 1. Repair harness or connector.
- 2. Confirm that magnet clutch operation is normal.

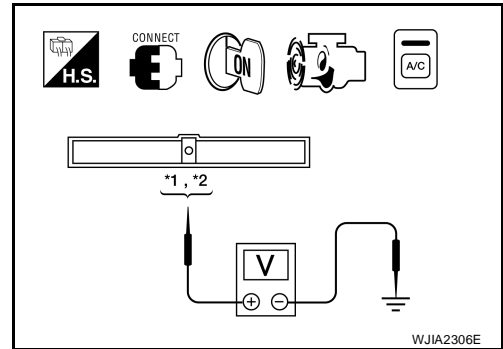

6. CHECK REFRIGERANT PRESSURE SENSOR

Refer to [EC-553, "REFRIGERANT PRESSURE SENSOR"](#) .

OK or NG

- OK >> GO TO 7.
- NG >> Replace refrigerant pressure sensor. Refer to [MTC-105, "Removal and Installation for Refrigerant Pressure Sensor"](#) .

7. CHECK COMPRESSOR ON SIGNAL

Check voltage between front air control connector M33 terminal 40 and ground, with A/C compressor ON and with A/C compressor OFF.

Terminal		Voltage (V) (Approx.)
(+)	(-)	
Connector - Terminal	Body ground	A/C Compressor ON: 0V A/C Compressor OFF: 5V
M33 - 40		

OK or NG

- OK >> GO TO 8.
- NG >>
 - When A/C compressor is ON and voltage is not approx. 0V, Replace front air control. Refer to [MTC-77, "FRONT AIR CONTROL"](#) .
 - When A/C compressor is OFF and voltage is not approx. 5V, BCM is malfunctioning.

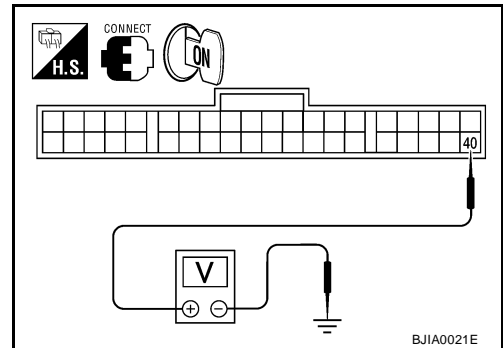

8. CHECK CAN COMMUNICATION CIRCUITS

Check CAN communication circuits between BCM to ECM and between ECM to IPDM E/R. Refer to [LAN-7, "TROUBLE DIAGNOSIS"](#) .

OK or NG

- OK >> ECM malfunctioning.
- NG >> Repair or replace component based on the result of diagnosis.

A
B
C
D
E
F
G
H
I
MTC
K
L
M

TROUBLE DIAGNOSIS

EJS005P5

Insufficient Cooling

SYMPTOM: Insufficient cooling

INSPECTION FLOW

1. CONFIRM SYMPTOM BY PERFORMING OPERATIONAL CHECK - TEMPERATURE DECREASE

1. Turn temperature control dial counterclockwise to maximum cold position.
2. Check for cold air at discharge air outlets.

Can the symptom be duplicated?

- YES >> GO TO 3.
NO >> GO TO 2.

2. CHECK FOR ANY SYMPTOMS

Perform a complete operational check for any symptoms. Refer to [MTC-43, "Operational Check"](#) .

Does another symptom exist?

- YES >> Refer to [MTC-31, "SYMPTOM TABLE"](#) .
NO >> System OK.

3. CHECK FOR SERVICE BULLETINS

Check for any service bulletins.

>> GO TO 4.

4. CHECK COMPRESSOR DRIVE BELT TENSION

Check compressor belt tension. Refer to [EM-15, "Checking Drive Belts"](#) .

OK or NG

- OK >> GO TO 5.
NG >> Adjust or replace compressor belt. Refer to [EM-15, "Removal and Installation"](#) .

5. CHECK AIR MIX DOOR OPERATION

Check and verify air mix door mechanism for smooth operation in each mode.

Does air mix door operate correctly?

- YES >> GO TO 6.
NO >> Repair or replace as necessary.

6. CHECK COOLING FAN MOTOR OPERATION

Check and verify cooling fan motor for smooth operation. Refer to [EC-420, "System Description"](#) .

Does cooling fan motor operate correctly?

- YES >> GO TO 7.
NO >> Check cooling fan motor. Refer to [EC-420, "DTC P1217 ENGINE OVER TEMPERATURE"](#) .

7. CHECK RECOVERY/RECYCLING EQUIPMENT BEFORE USAGE

Check recovery/recycling equipment before connecting to vehicle. Verify there is no pressure in the recovery/recycling equipment by checking the gauges. If pressure exists, recover refrigerant from equipment lines.

>> GO TO 8.

TROUBLE DIAGNOSIS

8. CHECK REFRIGERANT PURITY

1. Connect recovery/recycling equipment to vehicle.
2. Confirm refrigerant purity in supply tank using recovery/recycling and refrigerant identifier.

OK or NG

OK >> GO TO 9.

NG >> Check contaminated refrigerant. Refer to [MTC-4, "Contaminated Refrigerant"](#) .

9. CHECK FOR REFRIGERANT PRESSURE

Check refrigerant pressure with manifold gauge connected. Refer to [MTC-70, "Test Reading"](#) .

OK or NG

OK >> Perform performance test diagnoses. Refer to [MTC-68, "PERFORMANCE TEST ANALYSIS"](#) .

NG >> GO TO 10.

10. CHECK FOR EVAPORATOR FREEZE UP

Start engine and run A/C. Check for evaporator freeze up.

Does evaporator freeze up?

YES >> Perform performance test diagnoses. Refer to [MTC-68, "PERFORMANCE TEST ANALYSIS"](#) .

NO >> GO TO 11.

11. CHECK AIR DUCTS

Check ducts for air leaks.

OK or NG

OK >> If the symptom still exists, perform a complete operational check. Refer to [MTC-43, "Operational Check"](#) . If other symptoms exist, refer to [MTC-31, "SYMPTOM TABLE"](#) .

NG >> Repair air leaks.

A

B

C

D

E

F

G

H

I

MTC

K

L

M

TROUBLE DIAGNOSIS

PERFORMANCE TEST ANALYSIS

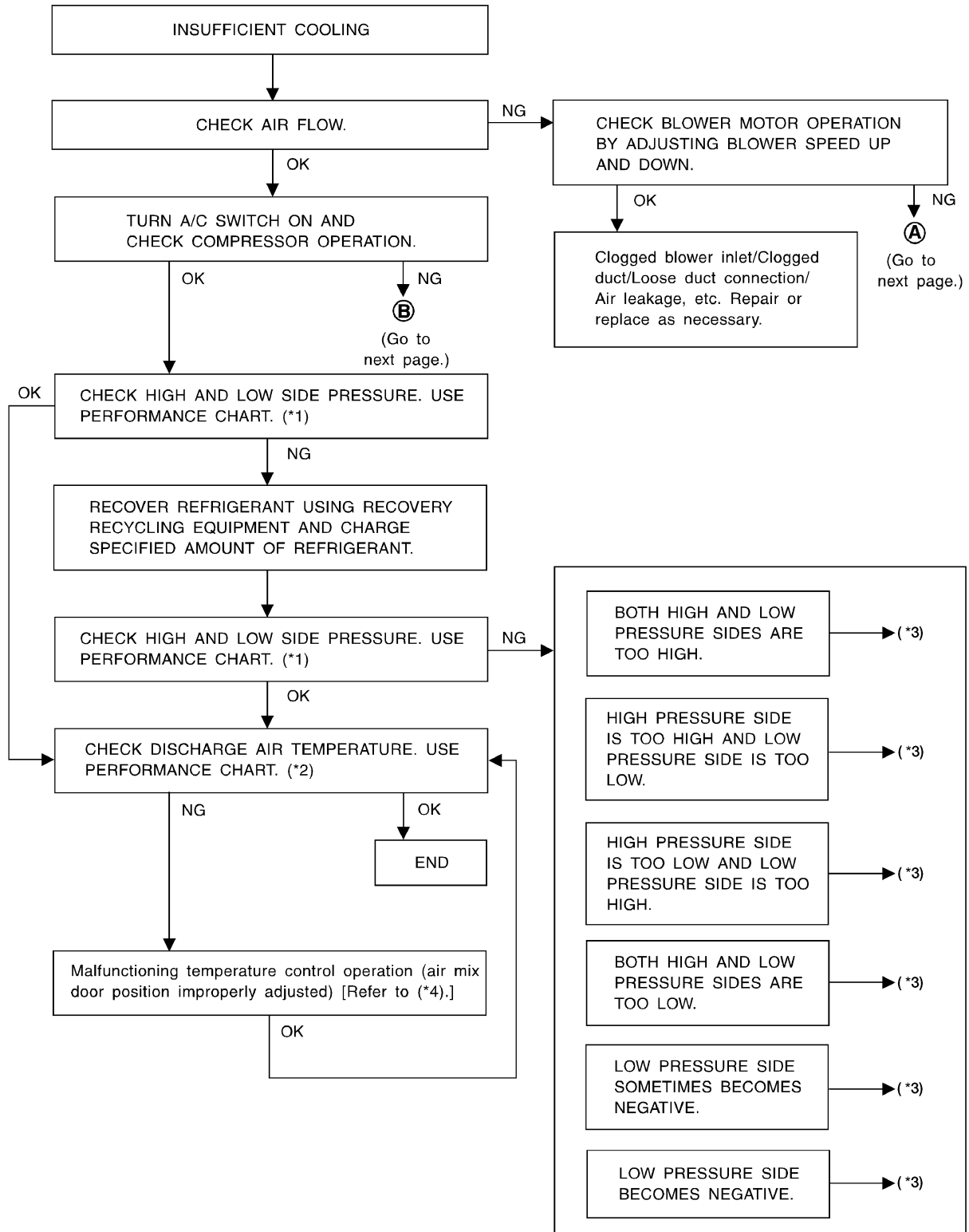

WJIA0198E

*1 [MTC-70, "PERFORMANCE CHART"](#) *2 [MTC-70, "Test Reading"](#)

*3 [MTC-70, "TROUBLE DIAGNOSIS FOR ABNORMAL PRESSURE"](#)

*4 [MTC-52, "Air Mix Door Motor Circuit"](#)

TROUBLE DIAGNOSIS

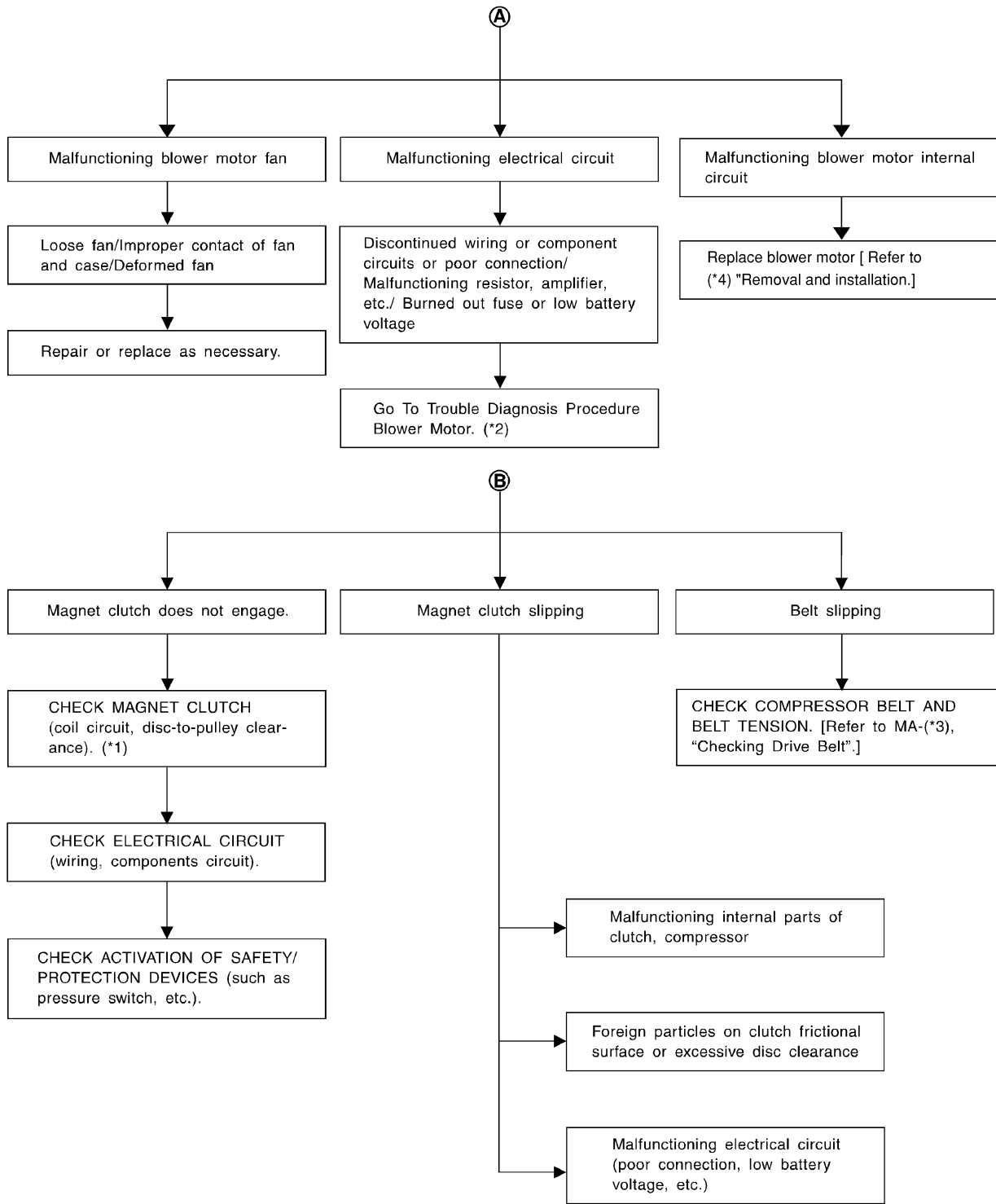

A
B
C
D
E
F
G
H
I
MTC
K
L
M

*1 [MTC-100, "INSTALLATION"](#)

*2 [MTC-78, "FRONT BLOWER MOTOR"](#)

*3 [EM-15, "Checking Drive Belts"](#)

*4 [MTC-78, "Removal and Installation"](#)



WJIA0749E

TROUBLE DIAGNOSIS

PERFORMANCE CHART

Test Condition

Testing must be performed as follows:

Vehicle location	Indoors or in the shade (in a well-ventilated place)
Doors	Closed
Door windows	Open
Hood	Open
TEMP.	Max. COLD
Mode switch	 (Ventilation) set
Intake switch	 (Recirculation) set
 (fan) speed	Max. speed set
Engine speed	Idle speed

Operate the air conditioning system for 10 minutes before taking measurements.

Test Reading

Recirculating-to-discharge Air Temperature Table

Inside air (Recirculating air) at blower assembly inlet		Discharge air temperature at center ventilator °C (°F)
Relative humidity %	Air temperature °C (°F)	
50 - 60	25 (77)	10.0 - 12.3 (50 - 54)
	30 (86)	13.2 - 15.3 (56 - 60)
	35 (95)	17.2 - 21.0 (63 - 70)
60 - 70	25 (77)	12.3 - 14.9 (54 - 59)
	30 (86)	15.3 - 19.3 (60 - 67)
	35 (95)	21.0 - 24.4 (70 - 76)

Ambient Air Temperature-to-operating Pressure Table

Ambient air		High-pressure (Discharge side) kPa (kg/cm ² , psi)	Low-pressure (Suction side) kPa (kg/cm ² , psi)
Relative humidity %	Air temperature °C (°F)		
50 - 70	30 (86)	1,220 - 1,500 (12.44 - 15.30, 176.9 - 217.5)	240 - 295 (2.45 - 3.01, 34.8 - 42.8)
	35 (95)	1,360 - 1,690 (13.87 - 17.24, 197.2 - 245.1)	275 - 335 (2.81 - 3.42, 39.9 - 48.6)
	40 (104)	1,500 - 1,830 (12.44 - 18.67, 176.9 - 265.4)	310 - 375 (3.16 - 3.83, 45.0 - 54.4)

TROUBLE DIAGNOSIS FOR ABNORMAL PRESSURE

Whenever system's high and/or low side pressure is abnormal, diagnose using a manifold gauge. The marker above the gauge scale in the following tables indicates the standard (normal) pressure range. Since the standard (normal) pressure differs from vehicle to vehicle, refer to Ambient Air Temperature-to-operating Pressure Table above.

TROUBLE DIAGNOSIS

Both High- and Low-pressure Sides are Too High

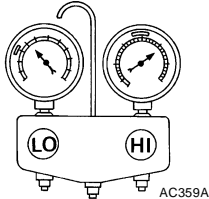
Gauge indication	Refrigerant cycle	Probable cause	Corrective action
<p>Both high and low-pressure sides are too high.</p> 	Pressure is reduced soon after water is splashed on condenser.	Excessive refrigerant charge in refrigeration cycle	Reduce refrigerant until specified pressure is obtained.
	Air suction by cooling fan is insufficient.	Insufficient condenser cooling performance ↓ 1. Condenser fins are clogged. 2. Improper fan rotation of cooling fan	<ul style="list-style-type: none"> Clean condenser. Check and repair cooling fan as necessary.
	<ul style="list-style-type: none"> Low-pressure pipe is not cold. When compressor is stopped high-pressure value quickly drops by approximately 196 kPa (2 kg/cm², 28 psi). It then decreases gradually thereafter. 	Poor heat exchange in condenser (After compressor operation stops, high pressure decreases too slowly.) ↓ Air in refrigeration cycle	Evacuate and recharge system.
	Engine tends to overheat.	Engine cooling systems malfunction.	Check and repair each engine cooling system.
	<ul style="list-style-type: none"> An area of the low-pressure pipe is colder than areas near the evaporator outlet. Plates are sometimes covered with frost. 	<ul style="list-style-type: none"> Excessive liquid refrigerant on low-pressure side Excessive refrigerant discharge flow Expansion valve is open a little compared with the specification. ↓ 1. Improper thermal valve installation 2. Improper expansion valve adjustment	Replace expansion valve.

High-pressure Side is Too High and Low-pressure Side is Too Low

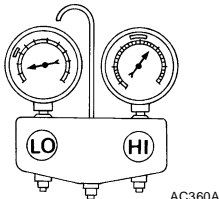
Gauge indication	Refrigerant cycle	Probable cause	Corrective action
<p>High-pressure side is too high and low-pressure side is too low.</p> 	Upper side of condenser and high-pressure side are hot, however, liquid tank is not so hot.	High-pressure tube or parts located between compressor and condenser are clogged or crushed.	<ul style="list-style-type: none"> Check and repair or replace malfunctioning parts. Check oil for contamination.

High-pressure Side is Too Low and Low-pressure Side is Too High

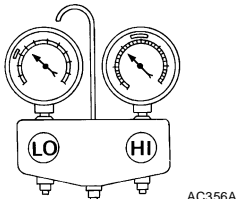
Gauge indication	Refrigerant cycle	Probable cause	Corrective action
<p>High-pressure side is too low and low-pressure side is too high.</p> 	High and low-pressure sides become equal soon after compressor operation stops.	Compressor pressure operation is improper. ↓ Damaged inside compressor pickings	Replace compressor.
	No temperature difference between high and low-pressure sides	Compressor pressure operation is improper. ↓ Damaged inside compressor pickings.	Replace compressor.

TROUBLE DIAGNOSIS

Both High- and Low-pressure Sides are Too Low

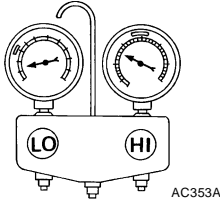
Gauge indication	Refrigerant cycle	Probable cause	Corrective action
<p>Both high- and low-pressure sides are too low.</p> 	<ul style="list-style-type: none"> There is a big temperature difference between liquid tank outlet and inlet. Outlet temperature is extremely low. Liquid tank inlet and expansion valve are frosted. 	Liquid tank inside is slightly clogged.	<ul style="list-style-type: none"> Replace desiccant assembly. Check oil for contamination.
	<ul style="list-style-type: none"> Temperature of expansion valve inlet is extremely low as compared with areas near liquid tank. Expansion valve inlet may be frosted. Temperature difference occurs somewhere in high-pressure side 	High-pressure pipe located between receiver drier and expansion valve is clogged.	<ul style="list-style-type: none"> Check and repair malfunctioning parts. Check oil for contamination.
	Expansion valve and liquid tank are warm or only cool when touched.	Low refrigerant charge ↓ Leaking fittings or components	Check refrigerant for leaks. Refer to Checking Refrigerant Leaks, MTC-107, "Checking for Refrigerant Leaks" and MTC-108, "Electronic Refrigerant Leak Detector" .
	There is a big temperature difference between expansion valve inlet and outlet while the valve itself is frosted.	Expansion valve closes a little compared with the specification. ↓ 1. Improper expansion valve adjustment 2. Malfunctioning thermal valve 3. Outlet and inlet may be clogged.	<ul style="list-style-type: none"> Remove foreign particles by using compressed air. Check oil for contamination.
	An area of the low-pressure pipe is colder than areas near the evaporator outlet.	Low-pressure pipe is clogged or crushed.	<ul style="list-style-type: none"> Check and repair malfunctioning parts. Check oil for contamination.
	Air flow volume is not enough or is too low.	Evaporator is frozen.	<ul style="list-style-type: none"> Check thermo control amp. and intake sensor operation. Replace compressor.

Low-pressure Side Sometimes Becomes Negative

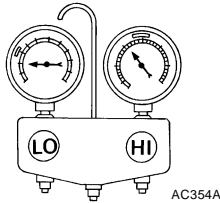
Gauge indication	Refrigerant cycle	Probable cause	Corrective action
<p>Low-pressure side sometimes becomes negative.</p> 	<ul style="list-style-type: none"> Air conditioning system does not function and does not cyclically cool the compartment air. The system constantly functions for a certain period of time after compressor is stopped and restarted. 	Refrigerant does not discharge cyclically. ↓ Moisture is frozen at expansion valve outlet and inlet. ↓ Water is mixed with refrigerant.	<ul style="list-style-type: none"> Drain water from refrigerant or replace refrigerant. Replace desiccant assembly.

TROUBLE DIAGNOSIS

Low-pressure Side Becomes Negative

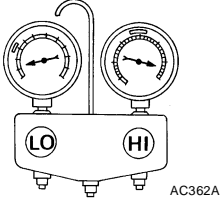
Gauge indication	Refrigerant cycle	Probable cause	Corrective action
<p>Low-pressure side becomes negative.</p> 	<p>Liquid tank or front/rear side of expansion valve's pipe is frosted or dewed.</p>	<p>High-pressure side is closed and refrigerant does not flow. ↓ Expansion valve or liquid tank is frosted.</p>	<p>Leave the system at rest until no frost is present. Start it again to check whether or not the problem is caused by water or foreign particles.</p> <ul style="list-style-type: none"> ● If water is the cause, initially cooling is okay. Then the water freezes causing a blockage. Drain water from refrigerant or replace refrigerant. ● If due to foreign particles, remove expansion valve and remove the particles with dry and compressed air (not shop air). ● If either of the above methods cannot correct the problem, replace expansion valve. ● Replace desiccant assembly. ● Check oil for contamination.

A
B
C
D
E
F
G
H
I

MTC

K
L
M

TROUBLE DIAGNOSIS

EJS005P6

Insufficient Heating

SYMPTOM: Insufficient heating

INSPECTION FLOW

1. CONFIRM SYMPTOM BY PERFORMING OPERATIONAL CHECK - TEMPERATURE DECREASE

1. Turn temperature control dial clockwise to maximum heat position.
2. Check for hot air at discharge air outlets.

Can the symptom be duplicated?

- YES >> GO TO 3.
NO >> GO TO 2.

2. CHECK FOR ANY SYMPTOMS

Perform a complete operational check for any symptoms. Refer to [MTC-43, "Operational Check"](#) .

Does another symptom exist?

- YES >> Refer to [MTC-31, "SYMPTOM TABLE"](#) .
NO >> System OK.

3. CHECK FOR SERVICE BULLETINS

Check for any service bulletins.

>> GO TO 4.

4. CHECK COOLANT SYSTEM

1. Check engine coolant level. Refer to [CO-10, "ENGINE COOLANT"](#) .
2. Check hoses for leaks or kinks.
3. Check radiator cap. Refer to [CO-14, "Checking Radiator Cap"](#) .

OK or NG

- OK >> GO TO 5.
NG >> Repair/replace as necessary.

5. CHECK AIR MIX DOOR OPERATION

Check and verify air mix door mechanism for smooth operation in each mode.

OK or NG

- OK >> GO TO 6.
NG >> Adjust or replace air mix door.

6. CHECK AIR DUCTS

Check ducts for air leaks.

OK or NG

- OK >> GO TO 7.
NG >> Repair air leaks.

7. CHECK HEATER HOSE TEMPERATURES

1. Start engine and warm it up to normal operating temperature.
2. Touch both the inlet and outlet heater hoses.

Is the inlet hose hot and the outlet hose warm?

- YES >> GO TO 8.
NO >> Both hoses warm: GO TO 9.

TROUBLE DIAGNOSIS

8. CHECK THERMOSTAT

Check thermostat for smooth operation.

OK or NG

OK >> System OK.

NG >> Repair or replace as necessary. Retest.

9. CHECK HEATER HOSES

Check heater hoses for proper installation.

OK or NG

OK >> GO TO 10.

NG >> Repair /replace as necessary. Retest GO TO 7.

10. BACK FLUSH HEATER CORE

1. Back flush heater core.
2. Drain the water from the system.
3. Refill system with new engine coolant. Refer to [CO-10, "Changing Engine Coolant"](#) .
4. Start engine and warm it up to normal operating temperature.
5. Touch both the inlet and outlet heater hoses.

Is the inlet hose hot and the outlet hose warm?

YES >> System OK.

NO >> Replace heater core and refill engine coolant. Refer to [MTC-83, "HEATER CORE"](#) .

A

B

C

D

E

F

G

H

I

MTC

K

L

M

TROUBLE DIAGNOSIS

EJS005P7

Noise

SYMPTOM: Noise

INSPECTION FLOW

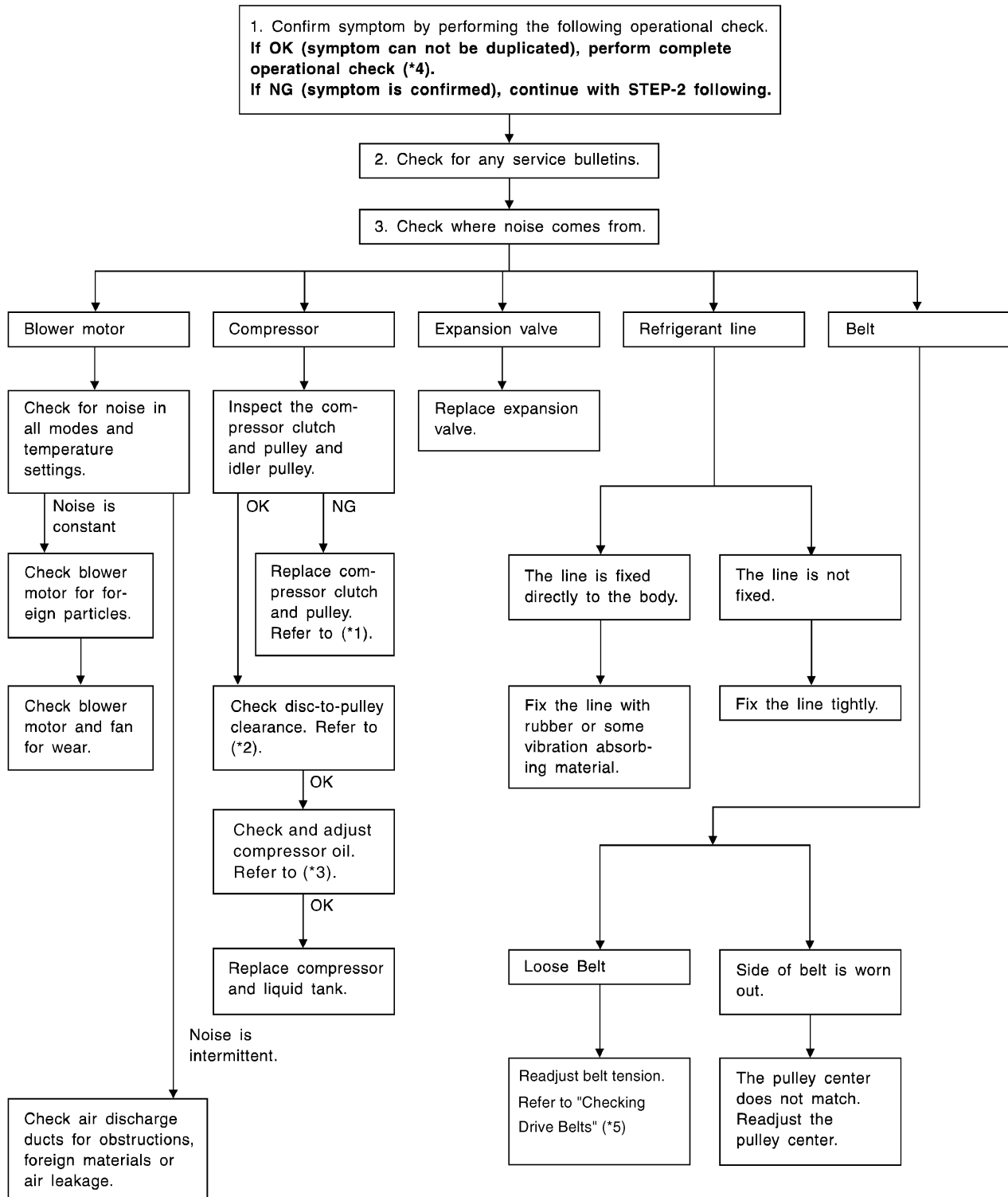

*1 [MTC-99, "Removal and Installation for Compressor Clutch - MR20DE"](#)

*2 [MTC-101, "INSPECTION AFTER INSTALLATION"](#)

*3 [MTC-21, "OIL"](#)

*4 [MTC-43, "Operational Check"](#)

*5 [EM-15, "Checking Drive Belts"](#)

WJIA1972E

CONTROL UNIT

CONTROL UNIT

PFP:27500

Removal and Installation FRONT AIR CONTROL

EJS005P9

Removal

1. Remove controller finisher. Refer to [IP-11, "INSTRUMENT PANEL ASSEMBLY"](#).
2. Remove the five screws (A) and remove the front air control (1).

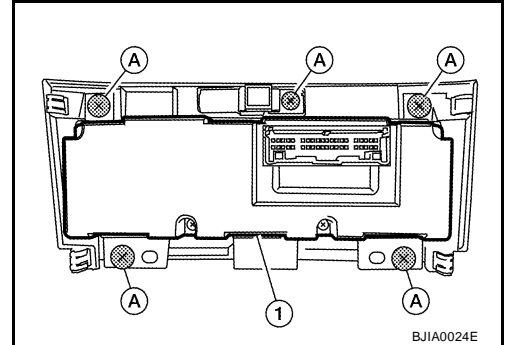

Installation

Installation is in the reverse order of removal.

A
B
C
D
E
F
G
H
I
K
L
M

MTC

FRONT BLOWER MOTOR

PF2:27226

EJS005PA

FRONT BLOWER MOTOR

Removal and Installation

REMOVAL

1. Remove the instrument panel. Refer to [IP-11, "INSTRUMENT PANEL ASSEMBLY"](#) .
2. Remove the BCM. Refer to [BCS-21, "Removal and Installation of BCM"](#) .
3. Disconnect the front blower motor connector (2).
4. Remove the one screw (A) from the front blower motor (1).
5. Turn the front blower motor (1) counterclockwise and remove it.
 - ← : Front

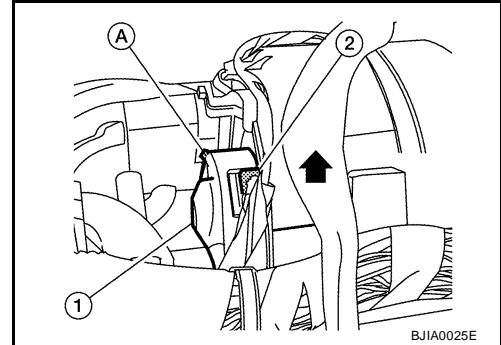

INSTALLATION

Installation is in the reverse order of removal.

IN-CABIN MICROFILTER

IN-CABIN MICROFILTER

PF2:27277

Removal and Installation FUNCTION

EJS005PB

Air inside passenger compartment is kept clean at either recirculation or fresh mode by installing in-cabin microfilter into heater and cooling unit assembly.

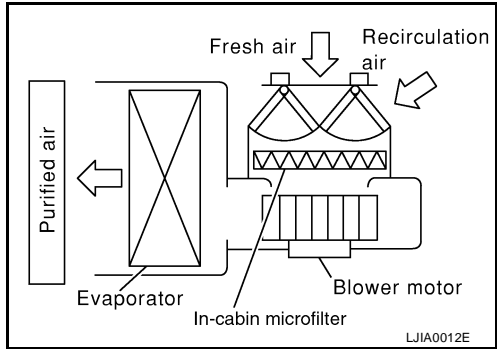

REPLACEMENT TIMING

Replace the in-cabin microfilter as recommended. Refer to [MA-8, "Schedule 1"](#) and [MA-11, "Schedule 2"](#).

REPLACEMENT PROCEDURES

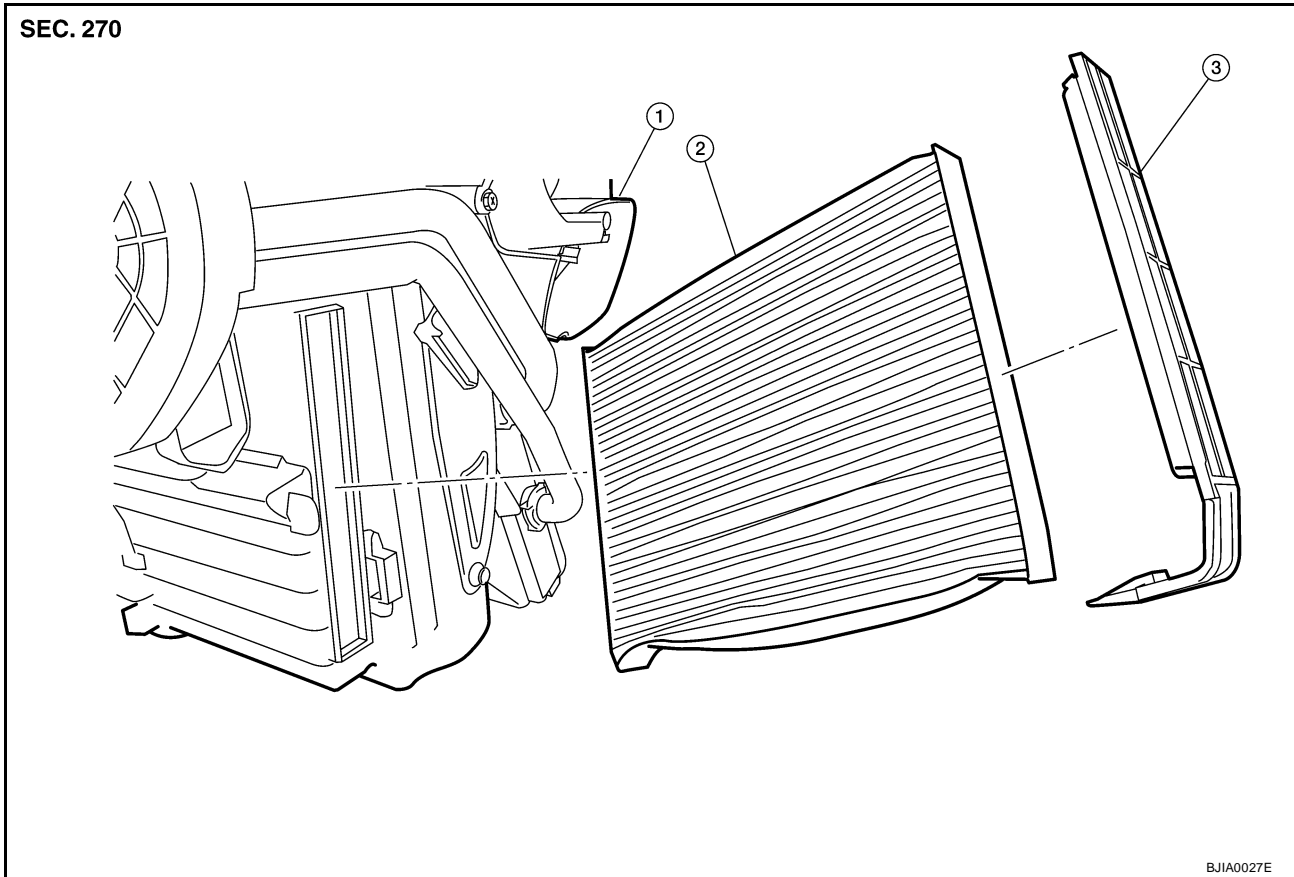

1. Heater and cooling unit assembly
2. In-cabin microfilter
3. Filter cover

A
B
C
D
E
F
G
H
I
MTC
K
L
M

IN-CABIN MICROFILTER

1. Remove the filter cover.
 - a. Release the filter cover tab (A) the pull the bottom of the filter cover out tilting it at an angle
 - b. Pull down the filter cover to disengage the hook at the top and remove the filter cover.

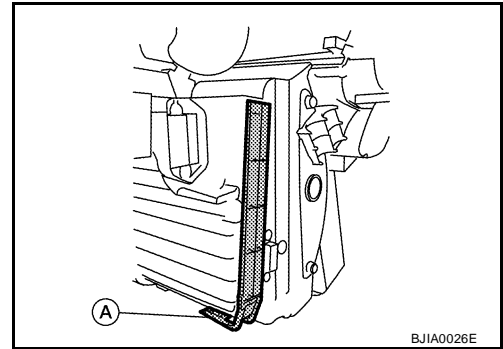

2. Remove the in-cabin microfilter.
3. Install the new in-cabin microfilter.

CAUTION:

- Insert the new filter with the “UP” arrow in the correct orientation.
- Insert the new filter with the “UP” arrow side of the filter facing the front of the vehicle.

4. Install the filter cover.
 - a. Insert the hook at the top of the filter cover into the heater and cooling unit case.
 - b. Swing the filter cover into the heater and cooling unit case until the filter cover tab (A) snaps securely on the heater and cooling unit case.

CAUTION:

Check the filter cover to make sure it is securely fastened to the heater and cooling unit case.

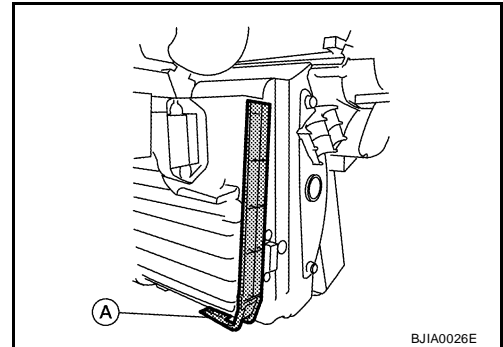

HEATER & COOLING UNIT ASSEMBLY

PFP:27110

HEATER & COOLING UNIT ASSEMBLY

Removal and Installation

EJS005PC

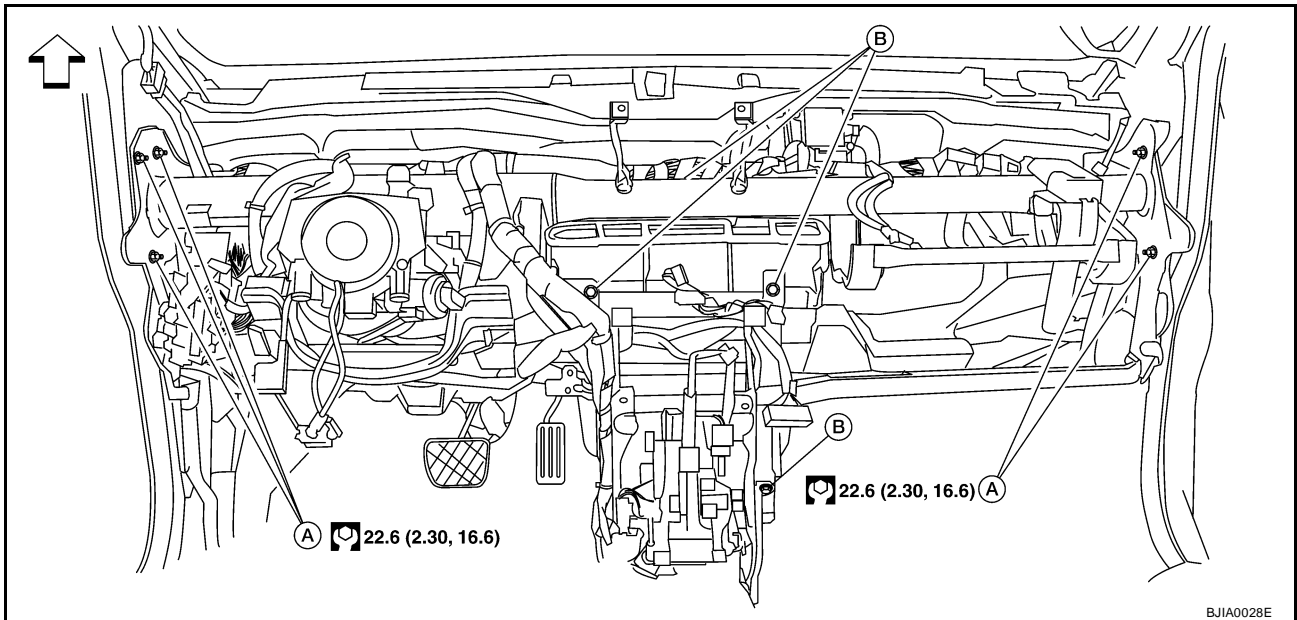

A. Steering member bolts

B. Heater and cooling unit assembly bolts

REMOVAL

1. Discharge the refrigerant from the A/C system. Refer to [MTC-92, "HFC-134a \(R-134a\) Service Procedure"](#).
2. Partially drain the engine coolant from the cooling system. Refer to [MA-17, "Changing Engine Coolant"](#).
3. Reposition the lower dash insulator out of the way.
4. Disconnect the heater hoses from the heater core pipes.

CAUTION:

Cap or wrap the joint of the pipe with suitable material such as vinyl tape to avoid entry of contaminants.

5. Disconnect the refrigerant lines from the evaporator. Refer to [MTC-94, "Components"](#).

CAUTION:

Cap or wrap the joint of the pipe with suitable material such as vinyl tape to avoid entry of contaminants.

6. Remove the steering column. Refer to [PS-9, "STEERING COLUMN"](#).
7. Remove the instrument panel assembly. Refer to [IP-11, "INSTRUMENT PANEL ASSEMBLY"](#).
8. Remove the lower steering member stays.
9. Disconnect the following components.
 - Shift lock cable
 - Steering harness clips
 - SMJ
 - Fuse box
 - Door harness
 - Front pillar harness
 - CVT shift cable (if equipped)
 - M/T shift cable (if equipped)
 - A/C drain hose
 - Air bag module control unit
10. Disconnect the evaporator drain hose.
11. Remove the steering member bolt caps.
12. Support both front doors with a suitable jack.

A
B
C
D
E
F
G
H
I
K
L
M

MTC

HEATER & COOLING UNIT ASSEMBLY

13. Remove both front door upper hinge bolts. Refer to [BL-144, "DOOR"](#) .
14. Remove the steering member bolts.
15. Temporarily install the front door upper hinge bolts.
16. Remove the heater and cooling unit and the steering member from the vehicle as one unit.

CAUTION:

Be careful not to damage the interior and seat trim when removing the heater and cooling unit assembly and steering member from the vehicle.

17. Disconnect the following components to separate the heater and cooling unit assembly from the steering member.
 - Front blower motor
 - Fan control amplifier
 - air mix door motor
 - Mode door motor
 - Intake door motor
18. Remove the heater and cooling unit assembly from the steering member.

INSTALLATION

Installation is in the reverse order of removal.

- Fill the radiator with the specified water and coolant mixture. Refer to [MA-17, "Changing Engine Coolant"](#) .
- Recharge the A/C system. Refer to [MTC-92, "HFC-134a \(R-134a\) Service Procedure"](#) .
- Check and adjust the front door alignment as necessary. Refer to [BL-144, "Fitting Adjustment"](#) .

HEATER CORE

HEATER CORE

PFP:27140

Removal and Installation

EJS005PD

1. Remove the heater and cooling unit assembly. Refer to [MTC-81, "Removal and Installation"](#).
2. Remove the heater core pipe support screws (A) and then remove it.

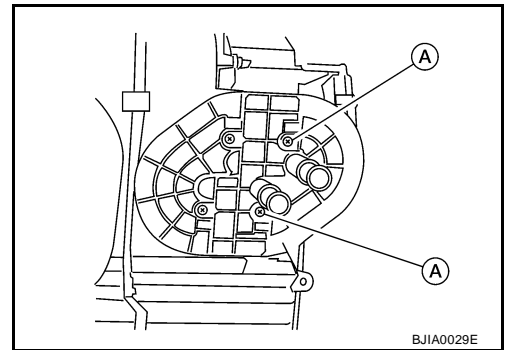

3. Remove the heater core (1) from the heater and cooling unit assembly (2).

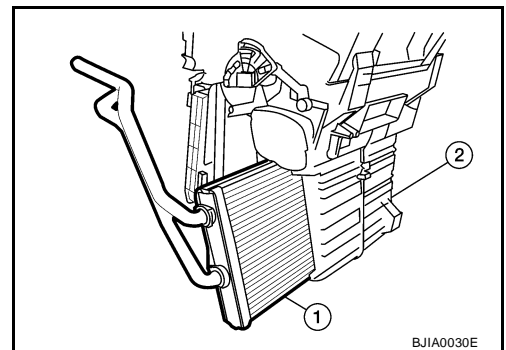

INSTALLATION

Installation is in the reverse order of removal.

A
B
C
D
E
F
G
H
I

MTC

K
L
M

INTAKE DOOR MOTOR

INTAKE DOOR MOTOR

PF2:27730

Removal and Installation

EJS005PE

REMOVAL

1. Remove the instrument panel assembly. Refer to [IP-11, "INSTRUMENT PANEL ASSEMBLY"](#) .
2. Disconnect the intake door motor connector (B).
3. Remove the screws (A) and then the intake door motor (1) from the heater and cooling unit assembly.

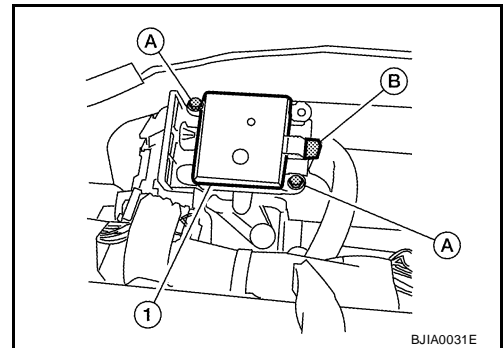

INSTALLATION

Installation is in the reverse order of removal.

MODE DOOR MOTOR

MODE DOOR MOTOR

PF2:27731

Removal and Installation

EJS005PF

1. Remove the instrument lower cover (LH). Refer to [IP-11, "INSTRUMENT PANEL ASSEMBLY"](#) .
2. Disconnect the mode door motor connector.
3. Remove the two mode door motor screws (A) and then remove the mode door motor (1).

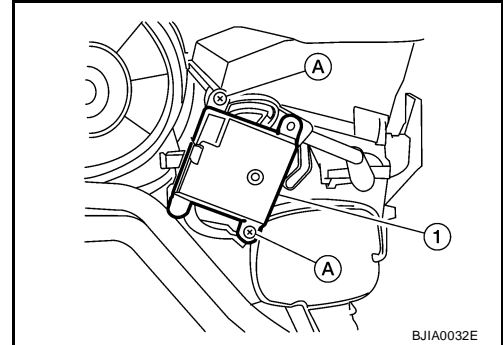

INSTALLATION

Installation is in the reverse order of removal.

A
B
C
D
E
F
G
H
I

MTC

K
L
M

AIR MIX DOOR MOTOR

AIR MIX DOOR MOTOR

PF2:27732

Removal and Installation

EJS005PG

REMOVAL

1. Remove the glove box lower finisher. Refer to [IP-10, "Component Parts"](#).
2. Disconnect the air mix door motor connector (B).
3. Remove the two air mix door motor screws (A) and then remove the air mix door motor (1).

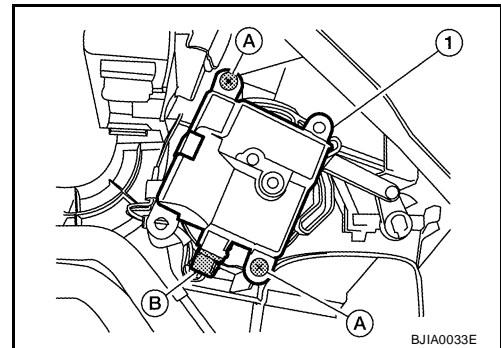

INSTALLATION

Installation is in the reverse order of removal.

FAN CONTROL AMPLIFIER

PFP:27761

FAN CONTROL AMPLIFIER

Removal and Installation

EJS005PH

1. Remove the instrument lower finisher. Refer to [IP-11, "INSTRUMENT PANEL ASSEMBLY"](#) .
2. Remove the front foot duct (LH). Refer to [MTC-88, "DUCTS AND GRILLES"](#) .
3. Remove the accelerator pedal. Refer to [ACC-3, "ACCELERATOR CONTROL SYSTEM"](#) .
4. Disconnect the fan control amplifier connector (B).
5. Remove the two screws (A) from the fan control amplifier (1) and then remove the fan control amplifier (1).

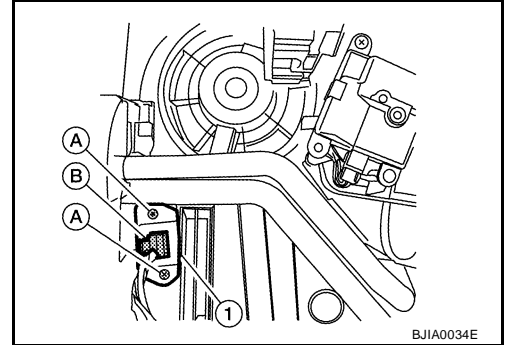

INSTALLATION

Installation is in the reverse order of removal.

A
B
C
D
E
F
G
H
I
K
L
M

MTC

DUCTS AND GRILLES

DUCTS AND GRILLES Removal and Installation

PFP:27860

EJS005PI

Ducts

SEC. 270 • 271 • 272 • 273

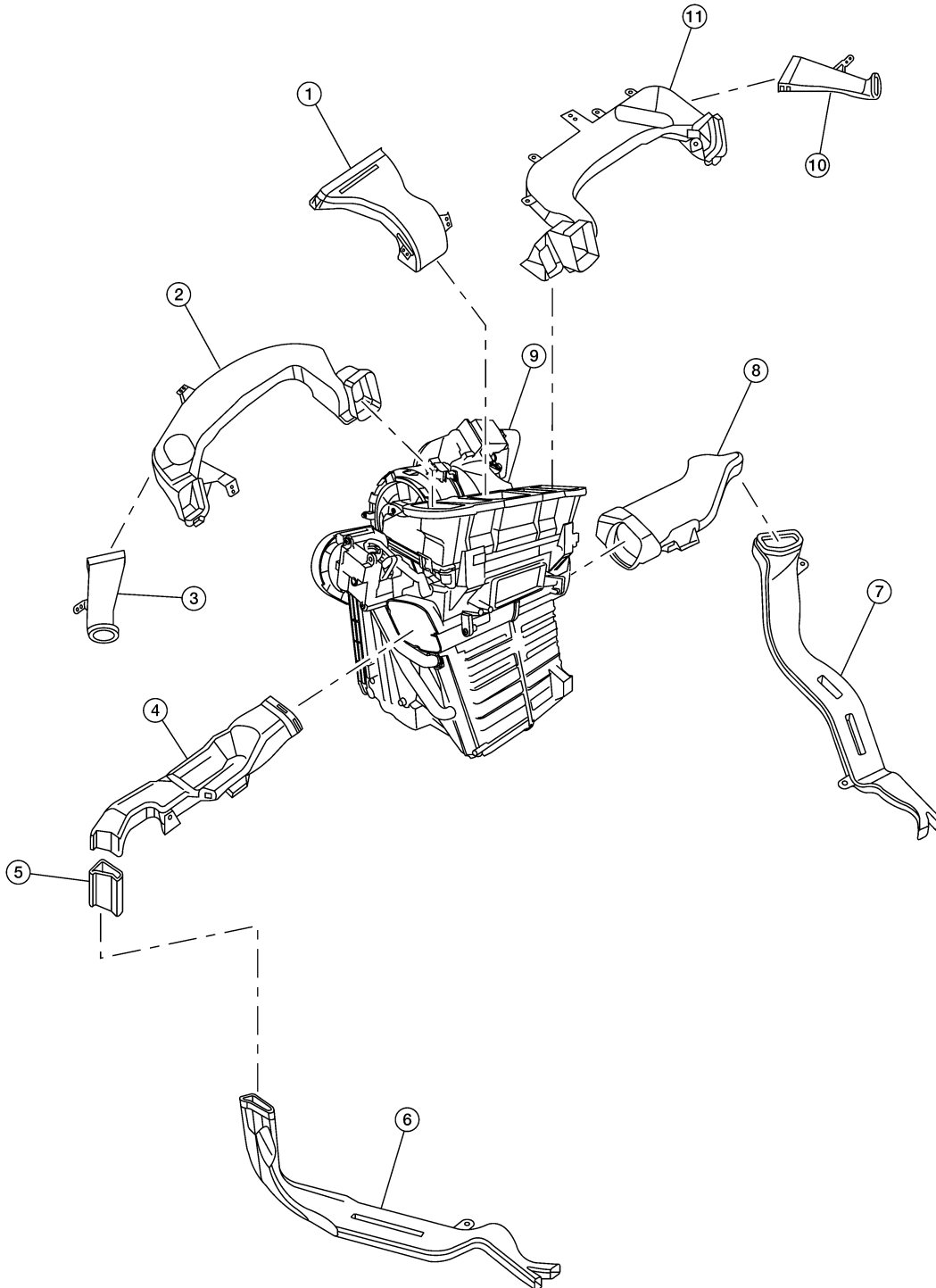

DUCTS AND GRILLES

- | | | |
|---------------------------------------|--|---------------------------------------|
| 1. Defroster nozzle | 2. Side ventilator duct (LH) | 3. Side defroster duct (LH) |
| 4. Front foot duct (LH) | 5. Rear floor connector duct (Canada only) | 6. Rear floor duct (LH) (Canada only) |
| 7. Rear floor duct (RH) (Canada only) | 8. Front foot duct (RH) | 9. Heater and cooling unit assembly |
| 10. Side defroster duct (RH) | 11. Side ventilator duct (RH) | |

Grilles

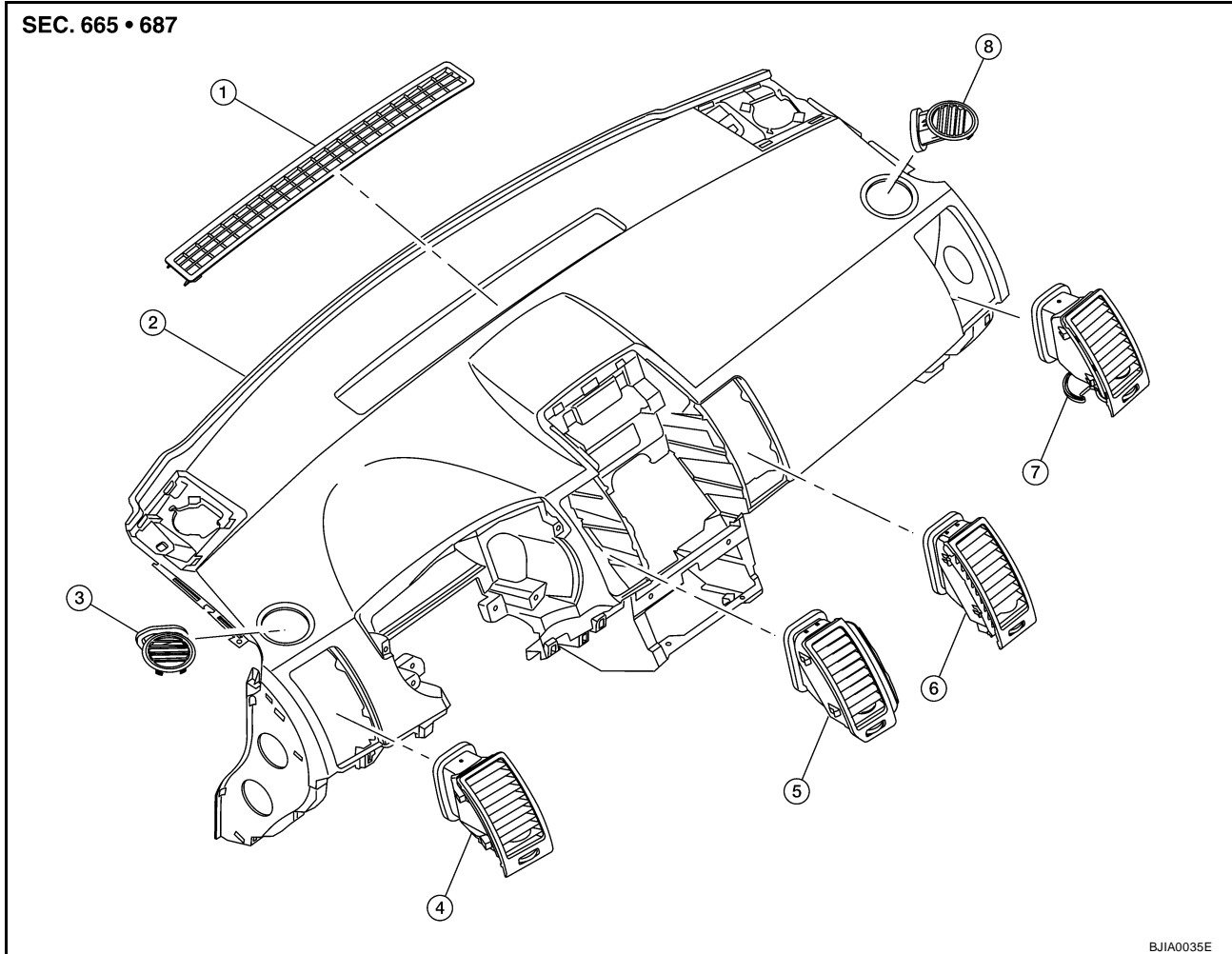

- | | | |
|--------------------------------|----------------------------------|----------------------------------|
| 1. Upper defroster grille | 2. Instrument panel assembly | 3. Side defroster grille (LH) |
| 4. Side ventilator grille (LH) | 5. Center ventilator grille (LH) | 6. Center ventilator grille (RH) |
| 7. Side ventilator grille (RH) | 8. Side defroster grille (RH) | |

CENTER VENTILATOR GRILLE RH, LH

Removal

Release the tabs using a suitable tool and then remove the center ventilator grille.

Installation

Installation is in the reverse order of removal.

UPPER DEFROSTER GRILLE

Removal

1. Pry from the rear (farthest from windshield) edge to release the tabs using a suitable tool.
2. Pry from the front (closest to windshield) edge to release the tabs using a suitable tool.
3. Remove the upper defroster grille.

Installation

Installation is in the reverse order of removal.

DUCTS AND GRILLES

SIDE VENTILATOR GRILLE RH, LH

Removal

Release the tabs using a suitable tool and then remove the side ventilator grille.

Installation

Installation is in the reverse order of removal.

SIDE DEFROSTER GRILLE RH, LH

Removal

Release the tabs using a suitable tool and then remove the side defroster grille.

Installation

Installation is in the reverse order of removal.

SIDE VENTILATOR DUCT RH, LH

Removal

1. Remove the instrument panel assembly. Refer to [IP-11, "INSTRUMENT PANEL ASSEMBLY"](#) .
2. Remove the defroster nozzle.
3. Remove the side ventilator duct.

Installation

Installation is in the reverse order of removal.

DEFROSTER NOZZLE

Removal

1. Remove the instrument panel assembly. Refer to [IP-11, "INSTRUMENT PANEL ASSEMBLY"](#) .
2. Remove the defroster nozzle.

Installation

Installation is in the reverse order of removal.

SIDE DEFROSTER DUCT RH, LH

Removal

1. Remove the instrument panel assembly. Refer to [IP-11, "INSTRUMENT PANEL ASSEMBLY"](#) .
2. Remove the defroster nozzle.
3. Remove the side defroster duct.

Installation

Installation is in the reverse order of removal.

FRONT FOOT DUCT RH

Removal

1. Remove the glove box lower finisher. Refer to [IP-10, "Component Parts"](#) .
2. Remove the front foot duct.

Installation

Installation is in the reverse order of removal.

FRONT FOOT DUCT LH

Removal

1. Remove the instrument lower finisher. Refer to [IP-17, "INSTRUMENT LOWER FINISHER"](#) .
2. Remove the front foot duct.

Installation

Installation is in the reverse order of removal.

REAR FLOOR CONNECTOR DUCT

Removal

1. Push up to disengage the rear floor connector duct from the rear floor duct (LH).

DUCTS AND GRILLES

2. Remove the rear floor connector duct.

Installation

Installation is in the reverse order of removal.

REAR FLOOR DUCT RH

Removal

1. Remove the floor carpet from the front floor area and remove the front floor spacer. Refer to [EI-37, "FLOOR TRIM"](#).
2. Remove the rear floor duct bolt.
3. Remove the rear floor duct.

Installation

Installation is in the reverse order of removal.

REAR FLOOR DUCT LH

Removal

1. Remove the floor carpet from the front floor area and remove the front floor spacer. Refer to [EI-37, "FLOOR TRIM"](#).
2. Remove the rear floor connector duct.
3. Remove the rear floor duct bolt.
4. Remove the rear floor duct.

Installation

Installation is in the reverse order of removal.

A

B

C

D

E

F

G

H

I

MTC

K

L

M

REFRIGERANT LINES

PF9:92600

EJS005PJ

REFRIGERANT LINES

HFC-134a (R-134a) Service Procedure SETTING OF SERVICE TOOLS AND EQUIPMENT

Discharging Refrigerant

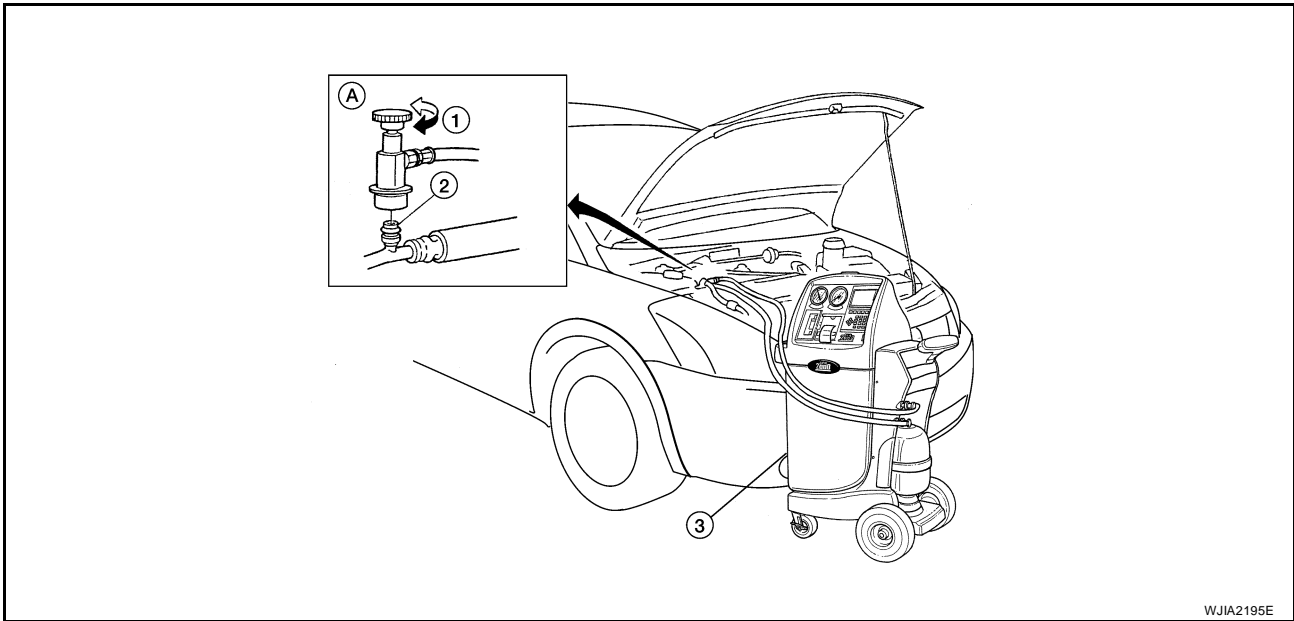

WJIA2195E

1. Shut-off valve
 2. A/C service valve
 3. Recovery/recycling equipment
- A. Preferred (best) method

WARNING:

Avoid breathing the A/C refrigerant and oil vapor or mist. Exposure may irritate eyes, nose, and throat. Remove the HFC-134a (R-134a) from the A/C system using certified service equipment meeting the requirements of SAE J2210 HFC-134a (R-134a) recycling equipment or J2201 HFC-134a (R-134a) recovery equipment. If an accidental system discharge occurs, ventilate the work area before resuming service. Additional health and safety information may be obtained from the refrigerant and oil manufacturers.

Evacuating System and Charging Refrigerant

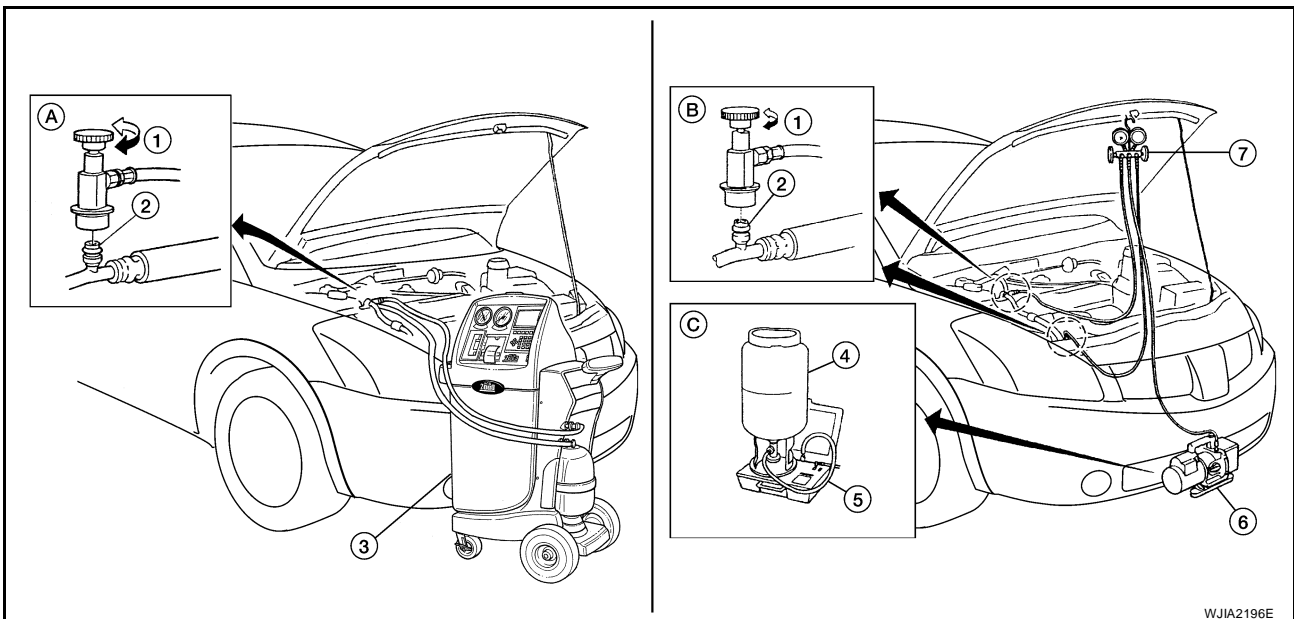

WJIA2196E

1. Shut-off valve
2. A/C service valve
3. Recovery/recycling equipment
4. Refrigerant container (HFC-134a)
5. Weight scale (J-39650)
6. Evacuating vacuum pump (J-39699)

REFRIGERANT LINES

7. Manifold gauge set (J-39183) A. Preferred (best) method B. Alternative method
 C. For charging

Discharging, Evacuating, and Recharging the A/C System

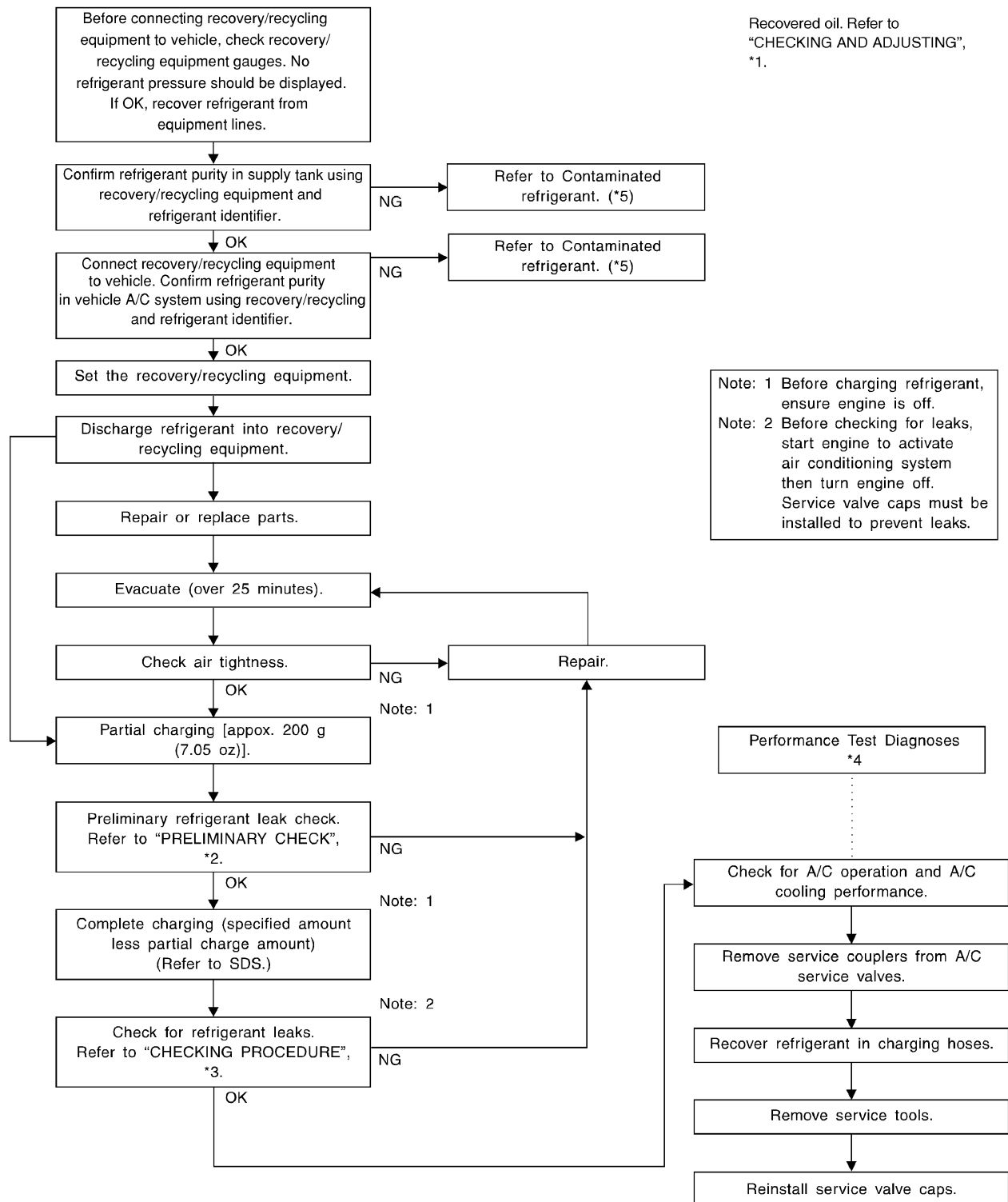

*1 [MTC-21, "CHECKING AND ADJUSTING"](#)

*2 [MTC-107, "Checking for Refrigerant Leaks"](#)

*3 [MTC-107, "Checking for Refrigerant Leaks"](#)

*4 [MTC-68, "PERFORMANCE TEST ANALYSIS"](#)

*5 [MTC-4, "Contaminated Refrigerant"](#)

WJIA1923E

REFRIGERANT LINES

Components

EJS005PK

MR20DE

SEC. 214 • 271 • 274 • 276

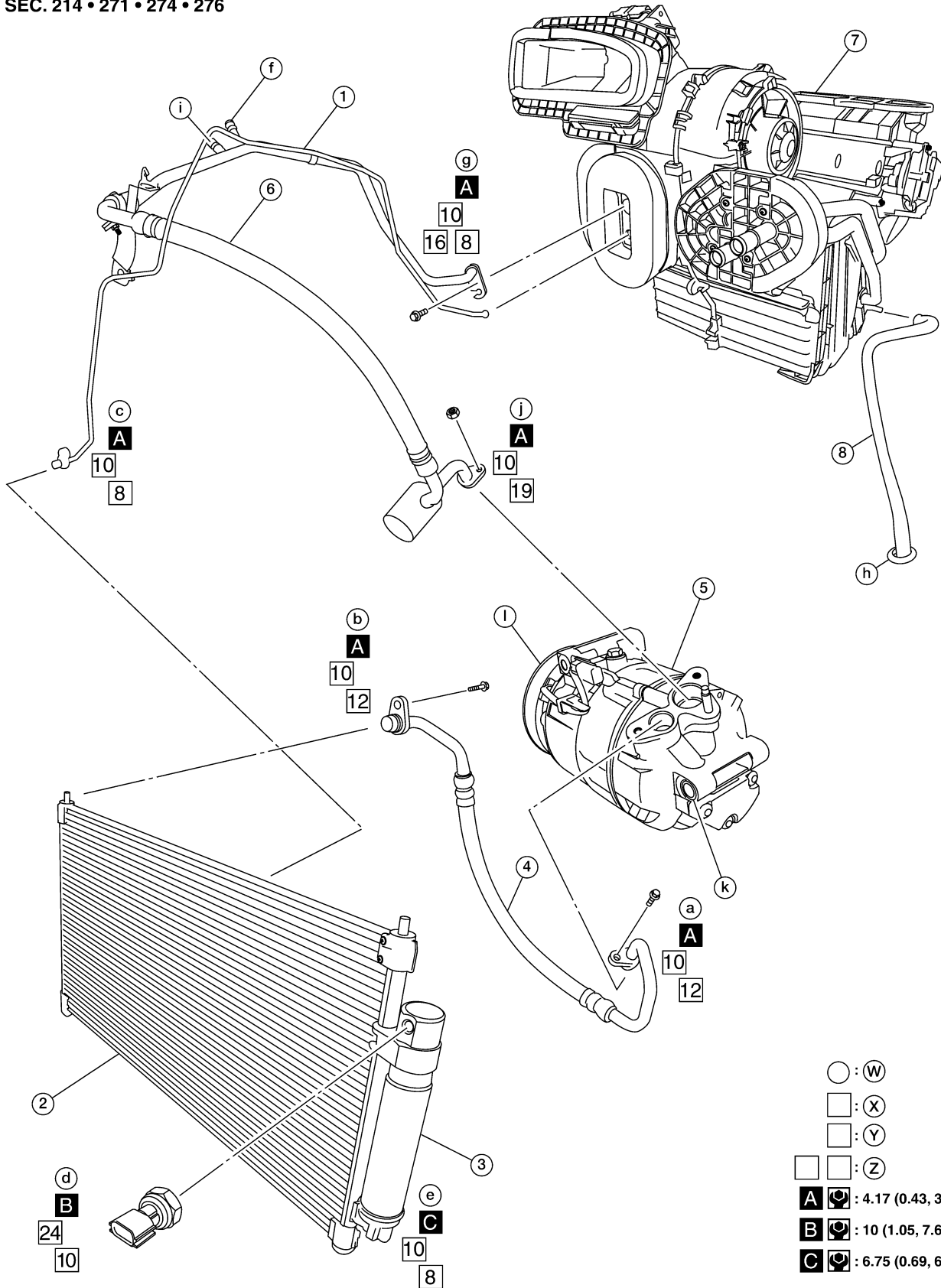

BJIA0022E

REFRIGERANT LINES

- | | | |
|-------------------------------------|----------------|------------------------------------|
| 1. High-pressure pipe | 2. Condenser | 3. Liquid tank |
| 4. High-pressure flexible hose | 5. Compressor | 6. Low-pressure flexible hose |
| 7. Heater and cooling unit assembly | 8. Drain hose | W. Refrigerant leak checking order |
| X. Tightening torque (A-C) | Y. Wrench size | Z. O-ring size |

A

B

C

D

E

F

G

H

I

MTC

K

L

M

REFRIGERANT LINES

QR25DE

SEC. 214 • 271 • 274 • 276

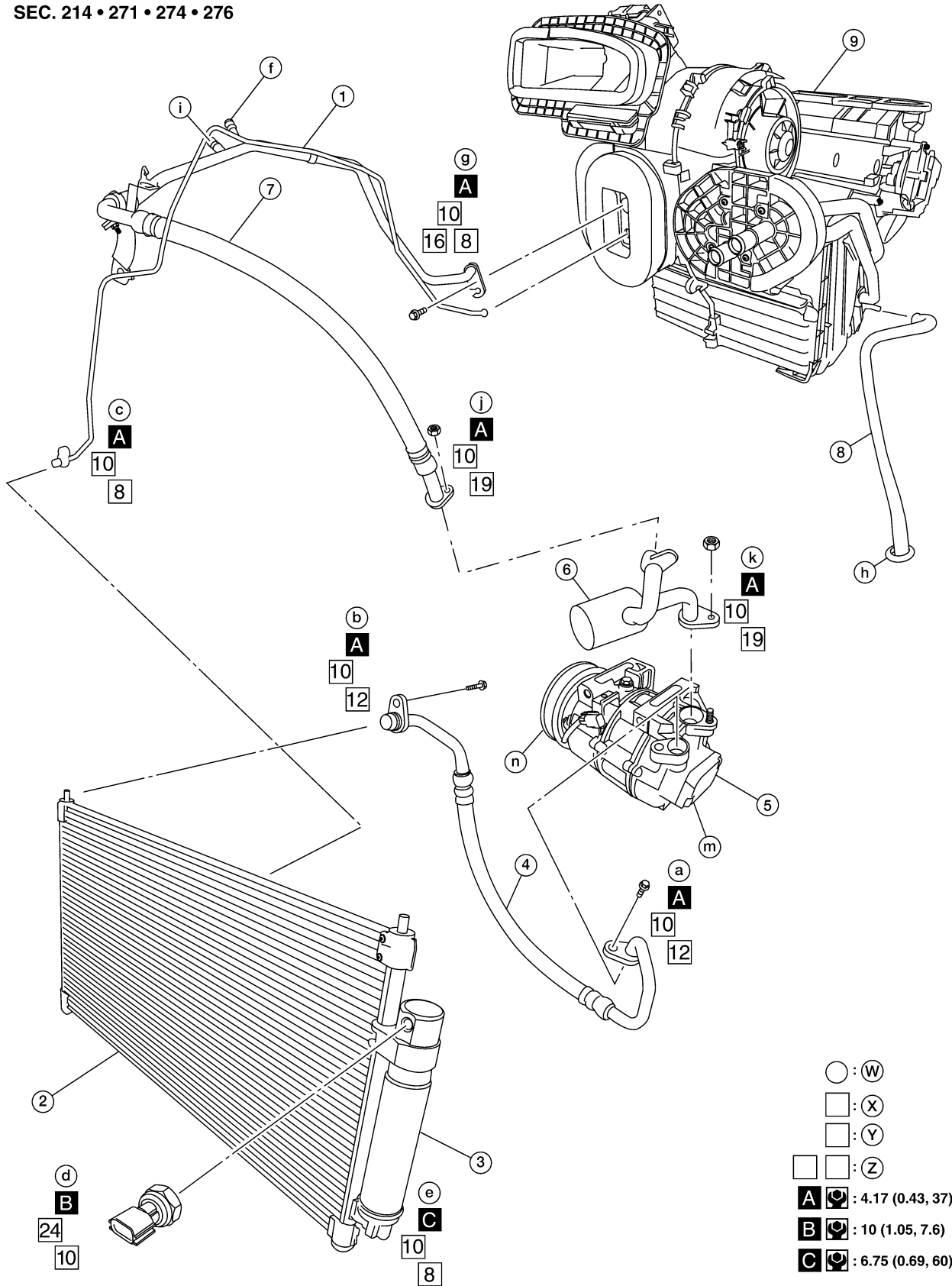

- 1. High-pressure pipe
- 4. High-pressure flexible hose

- 2. Condenser
- 5. Compressor

- 3. Liquid tank
- 6. Muffler pipe

WJIA2304E

REFRIGERANT LINES

- | | | |
|------------------------------------|----------------------------|-------------------------------------|
| 7. Low-pressure flexible hose | 8. Drain hose | 9. Heater and cooling unit assembly |
| W. Refrigerant leak checking order | X. Tightening torque (A-C) | Y. Wrench size |
| Z. O-ring size | | |

NOTE:

Refer to [MTC-5, "Precautions for Refrigerant Connection"](#).

Removal and Installation for Compressor - MR20DE

EJS005PL

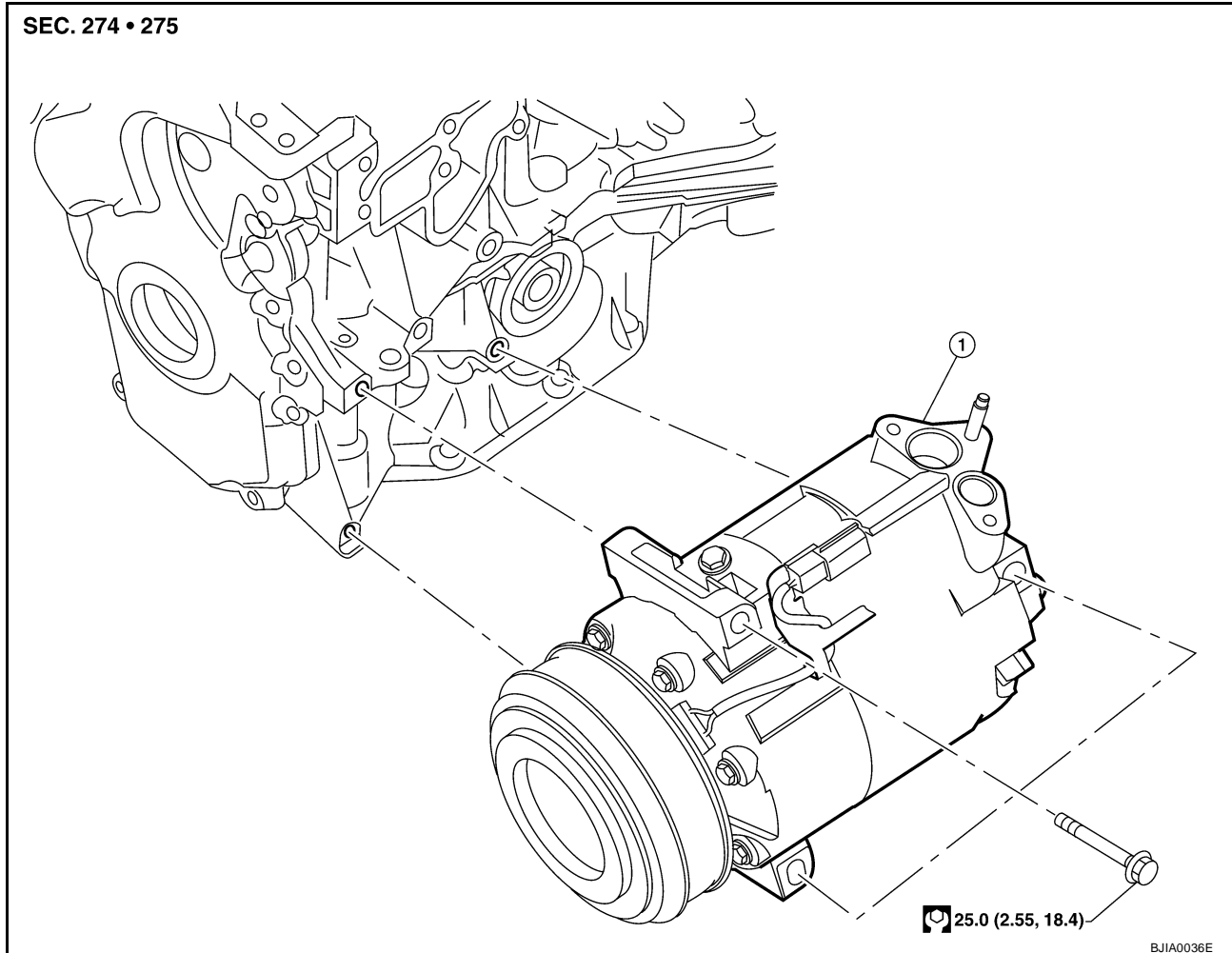

1. Compressor

REMOVAL

1. Discharge the refrigerant. Refer to [MTC-92, "HFC-134a \(R-134a\) Service Procedure"](#).
2. Remove the drive belt. Refer to [EM-15, "DRIVE BELTS"](#).
3. Disconnect the compressor connector.
4. Disconnect the high-pressure flexible hose and low-pressure flexible hose.

CAUTION:

Cap or wrap the joint of the hose with a suitable material such as vinyl tape to avoid the entry of any contaminants.

5. Remove the compressor bolts using power tool, then remove the compressor.

INSTALLATION

Installation is in the reverse order of removal.

CAUTION:

- Replace the O-ring of the low-pressure flexible hose and high-pressure flexible hose with new ones, then apply A/C oil to them for installation.

REFRIGERANT LINES

- After charging the A/C refrigerant, check for leaks. Refer to [MTC-107, "Checking for Refrigerant Leaks"](#) .

Removal and Installation for Compressor — QR25DE

EJS005Y3

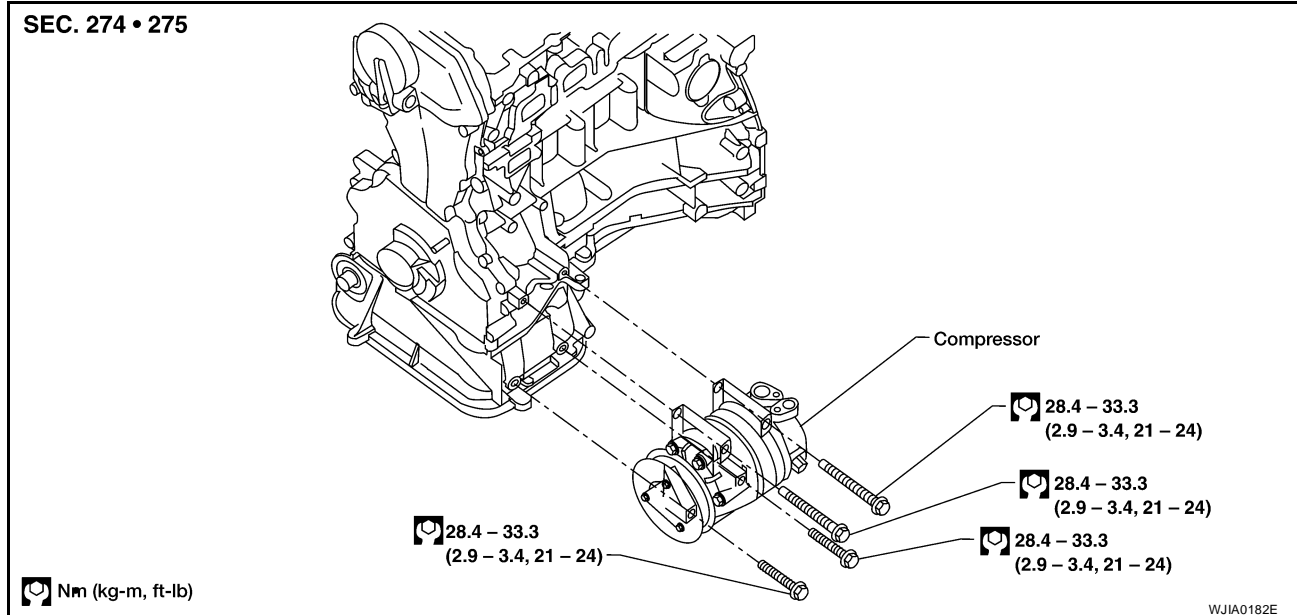

REMOVAL

1. Discharge the refrigerant. Refer to [MTC-92, "HFC-134a \(R-134a\) Service Procedure"](#) .
2. Partially drain the engine cooling system. Refer to [CO-34, "Changing Engine Coolant"](#) .
3. Disconnect the battery negative terminal.
4. Remove the front RH wheel and tire.
5. Remove the engine undercover.
6. Remove the front air duct. Refer to [EM-130, "Removal and Installation"](#) .
7. Disconnect the upper radiator hose from the radiator.
8. Disconnect the coolant reservoir hose from the radiator.
9. Remove the electric cooling fan assembly. Refer to [CO-39, "Removal and Installation"](#) .
10. Remove the drive belt. Refer to [EM-127, "Removal and Installation"](#) .
11. Disconnect the compressor connector.
12. Disconnect the high-pressure flexible hose and low-pressure flexible hose.

CAUTION:

Cap or wrap the joint of the hose with a suitable material such as vinyl tape to avoid the entry of any contaminants.

13. Remove the muffler pipe from the compressor.

CAUTION:

Cap or wrap the joint of the hose with a suitable material such as vinyl tape to avoid the entry of any contaminants.

14. Remove the compressor bolts using power tool, then remove the compressor.

INSTALLATION

Installation is in the reverse order of removal.

CAUTION:

- Replace the O-ring of the low-pressure flexible hose, muffler pipe and high-pressure flexible hose with new ones, then apply A/C oil to them for installation.
- After charging the A/C refrigerant, check for leaks. Refer to [MTC-107, "Checking for Refrigerant Leaks"](#) .

High and low-pressure flexible hose and muffler pipe nuts and bolt : Refer to [MTC-94, "Components"](#) .

REFRIGERANT LINES

Removal and Installation for Compressor Clutch - MR20DE

EJS005PN

REMOVAL

1. Remove the compressor. Refer to [MTC-97, "Removal and Installation for Compressor - MR20DE"](#).
2. Remove the center bolt by holding the clutch disc steady using a suitable tool (A).
3. Remove the clutch disc.

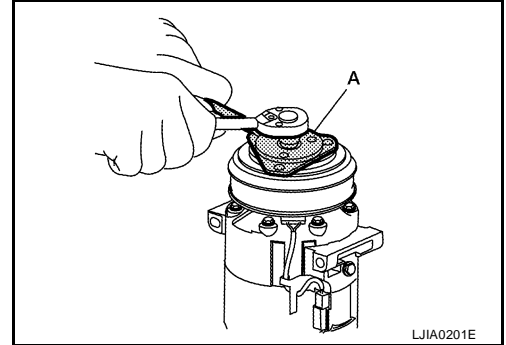

4. Remove the snap ring using external snap ring pliers.

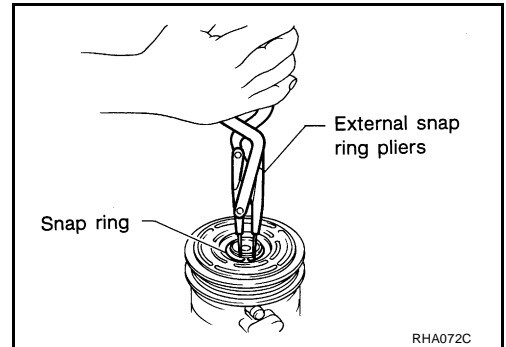

5. Remove the pulley assembly using Tool.
 - Use a pulley puller with a small adapter. Position the small adapter on the end of the compressor shaft and the center of the puller on the small adapter as shown.

Tool number : KV99233130 (J-29884)

CAUTION:

To prevent deformation of the pulley groove, the puller claws should be hooked under (not into) the pulley groove.

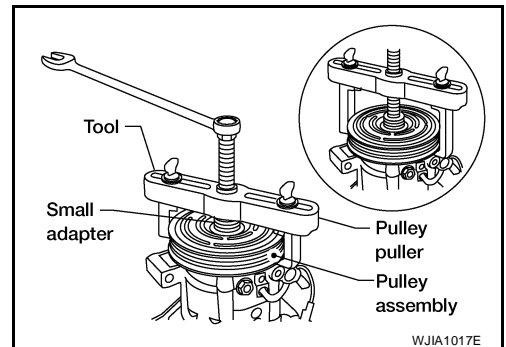

6. Remove the snap ring using external snap ring pliers.
7. Remove the magnet coil harness clip using a screwdriver.

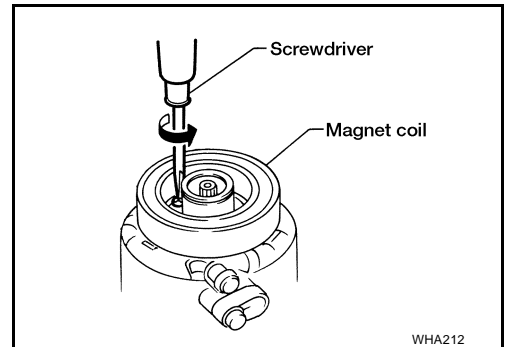

A
B
C
D
E
F
G
H
I
K
L
M

MTC

REFRIGERANT LINES

8. Remove the three magnet coil screws (B) and remove the magnet coil (5).
 - Shim (1)
 - Snap ring (2)
 - Clutch disc (3)
 - Pulley (4)
 - Center bolt (A)

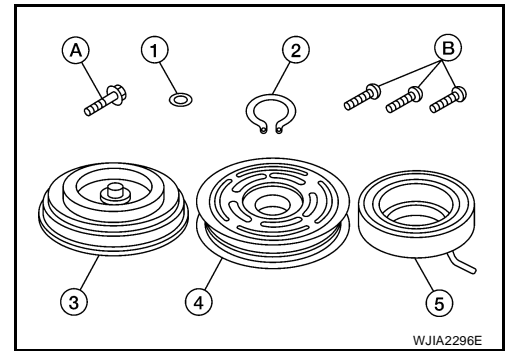

INSPECTION AFTER REMOVAL

Clutch Disc

If the contact surface shows signs of damage due to excessive heat, replace clutch disc and pulley.

Pulley

Check the appearance of the pulley assembly. If the contact surface of the pulley shows signs of excessive grooving, replace the clutch disc and pulley. The contact surfaces of the pulley assembly should be cleaned with a suitable solvent before installation.

Coil

Check the magnet coil for a loose connection or cracked insulation.

INSTALLATION

1. Install the magnet coil.

CAUTION:

Be sure to align the magnet coil pin with the hole in the compressor front head.

2. Install the magnet coil harness clip using a screwdriver.

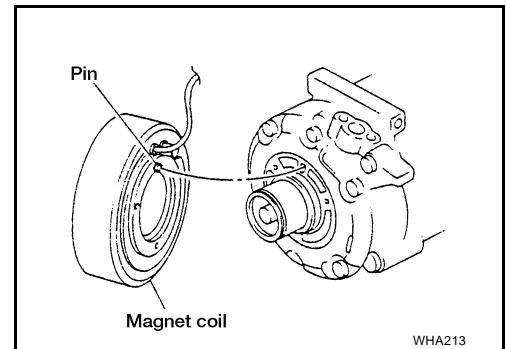

3. Install the pulley assembly using Tool and a wrench, and then install the snap ring using snap ring pliers.

Tool number : — (J-38873-A)

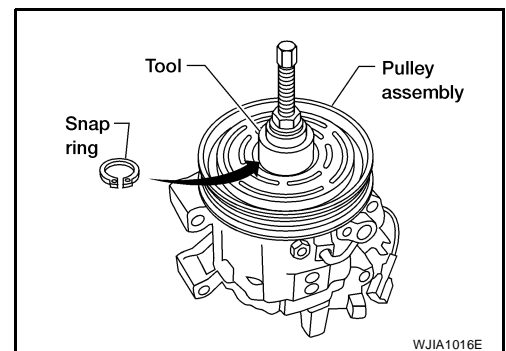

4. Install the clutch disc (1) on the drive shaft, together with the original shim(s) (2) using a suitable tool (A). Press the clutch disc down using Tool.

Tool number : — (J-38873-A)

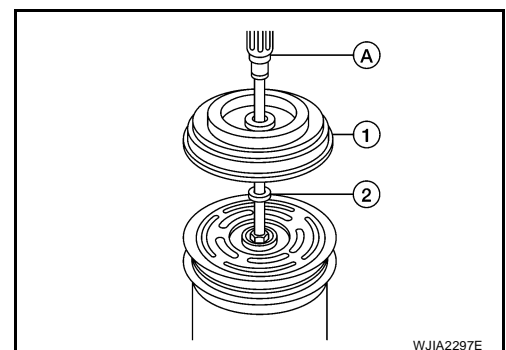

REFRIGERANT LINES

5. Install the center bolt using suitable tool (A).

Center bolt : 12 N-m (1.2 kg-m, 9 ft-lb).

- After tightening the center bolt to specification, check that the pulley rotates smoothly.

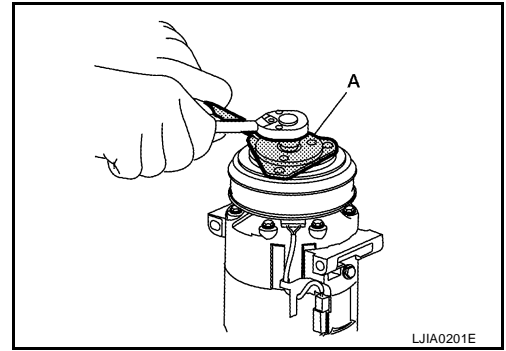

INSPECTION AFTER INSTALLATION

Check the clearance (B) all the way around between the clutch disc (1) and pulley (2) using a suitable tool (A) as shown.

**Clutch disc-to-pulley clearance (B) : 0.3 - 0.6 mm
(0.012 - 0.024 in)**

If the specified clearance (B) is not obtained, replace the adjusting shim(s) and recheck the clearance (B) as shown.

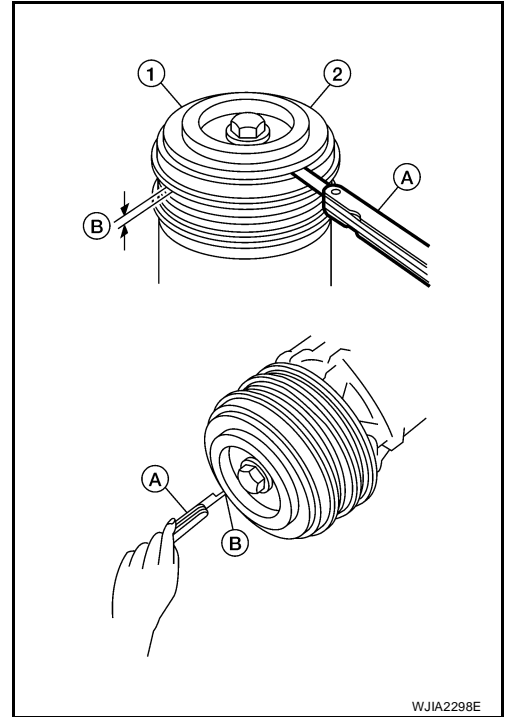

BREAK-IN OPERATION

When replacing compressor clutch assembly, always conduct the break-in operation. This is done by engaging and disengaging the clutch about 30 times. Break-in operation raises the level of transmitted torque.

Removal and Installation for Compressor Clutch - QR25DE

EJS005Y4

REMOVAL

1. Remove the compressor. Refer to [MTC-98, "Removal and Installation for Compressor — QR25DE"](#).
2. Remove the center bolt by holding the clutch disc steady using Tool.

Tool number : (J-44614)

3. Remove the clutch disc.

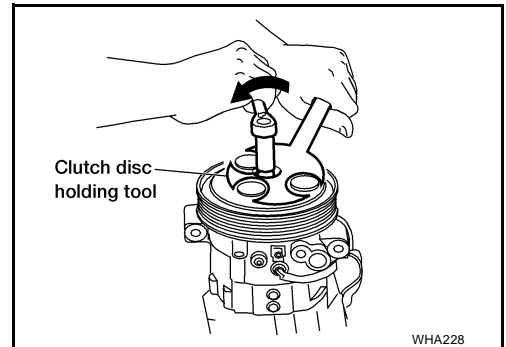

A
B
C
D
E
F
G
H
I
MTC
K
L
M

REFRIGERANT LINES

4. Remove the snap ring using external snap ring pliers.

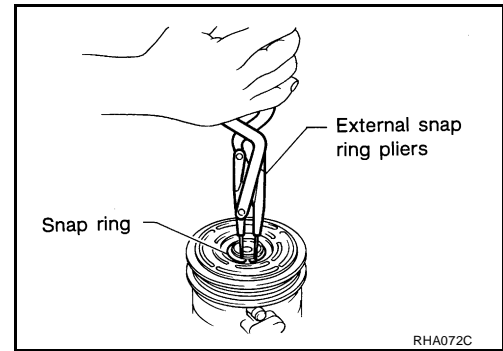

5. Remove the pulley assembly using Tool.
- Use a pulley puller with a small adapter. Position the small adapter on the end of the compressor shaft and the center of the puller on the small adapter as shown.

Tool number : KV99233130 (J-29884)

CAUTION:

To prevent deformation of the pulley groove, the puller claws should be hooked under (not into) the pulley groove.

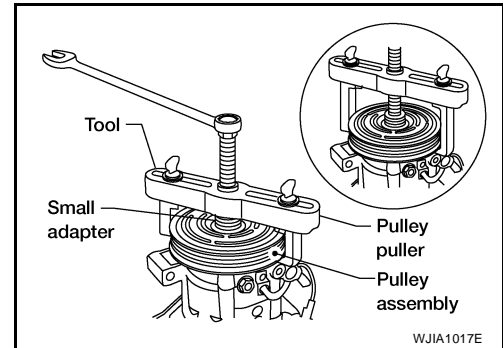

6. Remove the snap ring using external snap ring pliers.
7. Remove the magnet coil harness clip using a screwdriver.

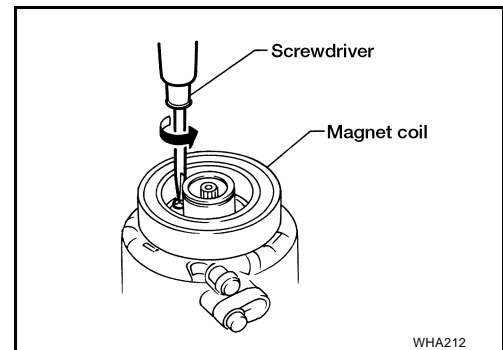

8. Remove the three magnet coil screws and remove the magnet coil.

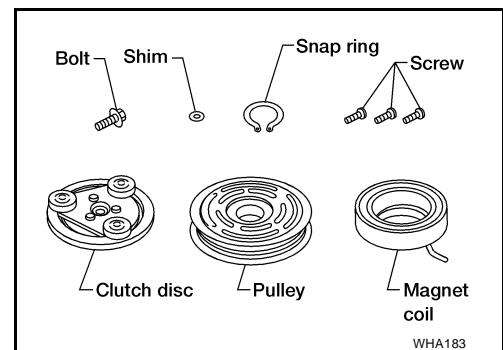

INSPECTION AFTER REMOVAL

Clutch Disc

If the contact surface shows signs of damage due to excessive heat, replace clutch disc and pulley.

Pulley

Check the appearance of the pulley assembly. If the contact surface of the pulley shows signs of excessive grooving, replace the clutch disc and pulley. The contact surfaces of the pulley assembly should be cleaned with a suitable solvent before installation.

Coil

Check the magnet coil for a loose connection or cracked insulation.

REFRIGERANT LINES

INSTALLATION

1. Install the magnet coil.

CAUTION:

Be sure to align the magnet coil pin with the hole in the compressor front head.

2. Install the magnet coil harness clip using a screwdriver.

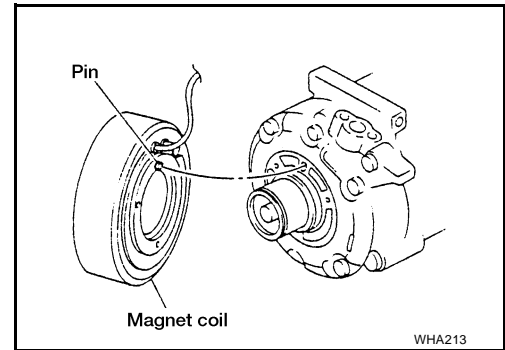

3. Install the pulley assembly using Tool and a wrench, and then install the snap ring using snap ring pliers.

Tool number : — (J-38873-A)

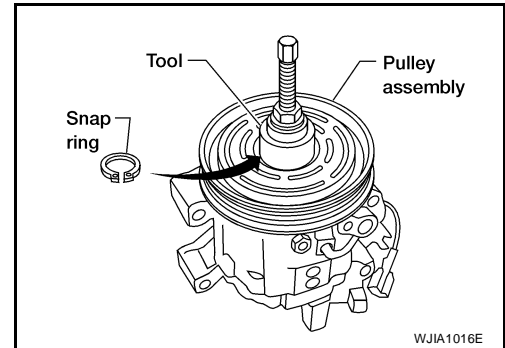

4. Install the clutch disc on the drive shaft, together with the original shim(s). Press the clutch disc down using the drive plate installer.

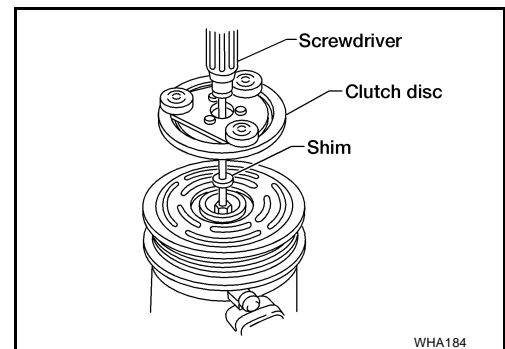

5. Install the center bolt using Tool.

Center bolt : 12 N-m (1.2 kg-m, 9 ft-lb).

Tool number : (J-44614)

- After tightening the center bolt to specification, check that the pulley rotates smoothly.

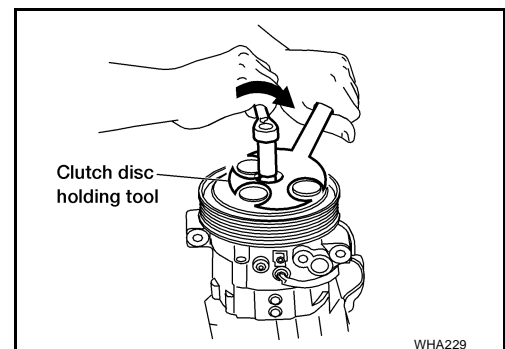

A
B
C
D
E
F
G
H
I
MTC
K
L
M

REFRIGERANT LINES

INSPECTION AFTER INSTALLATION

Check the clearance all the way around the clutch disc as shown.

**Clutch disc-to-pulley clearance : 0.3 - 0.6 mm
(0.012 - 0.024 in)**

If the specified clearance is not obtained, replace the adjusting spacer and recheck the clearance.

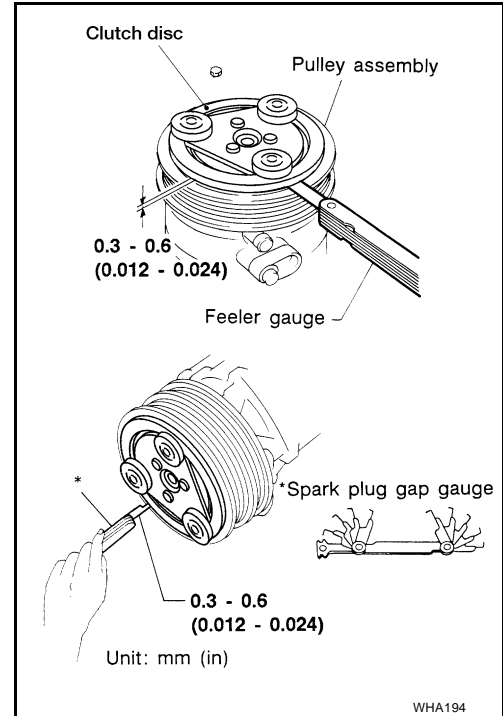

BREAK-IN OPERATION

When replacing compressor clutch assembly, always conduct the break-in operation. This is done by engaging and disengaging the clutch about 30 times. Break-in operation raises the level of transmitted torque.

Removal and Installation for Low-pressure Flexible Hose and Muffler Pipe

EJS005PO

NOTE:

The QR25DE models are equipped with a two piece low-pressure flexible hose and muffler pipe. The MR20DE models are a one piece low-pressure flexible hose and muffler assembly.

REMOVAL

1. Discharge the refrigerant. Refer to [MTC-92, "HFC-134a \(R-134a\) Service Procedure"](#).
2. Reposition the lower dash insulator.
3. Remove the low-pressure flexible hose (with muffler on MR20DE) and muffler pipe (QR25DE). Refer to [MTC-94, "Components"](#).

CAUTION:

Cap or wrap the joint of the hose with a suitable material such as vinyl tape to avoid the entry of contaminants.

4. Separate the low-pressure flexible hose and muffler pipe as necessary (QR25DE only). Refer to [MTC-94, "Components"](#).

CAUTION:

Cap or wrap the joint of the hose with a suitable material such as vinyl tape to avoid the entry of contaminants.

INSTALLATION

Installation is in the reverse order of removal.

CAUTION:

- Replace the O-rings on the low-pressure flexible hose and muffler pipe with new ones, then apply A/C oil to them for installation.
- After recharging the refrigerant, check for leaks. Refer to [MTC-107, "Checking for Refrigerant Leaks"](#).

Removal and Installation for High-pressure Flexible Hose

EJS005PP

REMOVAL

1. Discharge the refrigerant. Refer to [MTC-92, "HFC-134a \(R-134a\) Service Procedure"](#).

REFRIGERANT LINES

2. Remove the high-pressure flexible hose. Refer to [MTC-94, "Components"](#) .

CAUTION:

Cap or wrap the joint of the hose with a suitable material such as vinyl tape to avoid the entry of contaminants.

INSTALLATION

Installation is in the reverse order of removal.

CAUTION:

- Replace the O-ring of the high-pressure flexible hose with a new one, then apply A/C oil to it for installation.
- After charging the refrigerant, check for leaks. Refer to [MTC-107, "Checking for Refrigerant Leaks"](#)

Removal and Installation for High-pressure Pipe

EJS005PQ

REMOVAL

1. Discharge the refrigerant. Refer to [MTC-92, "HFC-134a \(R-134a\) Service Procedure"](#) .
2. Reposition the lower dash insulator.
3. Disconnect the low-pressure flexible hose bracket to reposition it out of the way.
4. Remove the high-pressure pipe. Refer to [MTC-94, "Components"](#) .

CAUTION:

Cap or wrap the joint of the pipe with suitable material such as vinyl tape to avoid the entry of air.

INSTALLATION

Installation is in the reverse order of removal.

CAUTION:

- Replace the O-ring of the high-pressure pipe with a new one, then apply compressor oil to it when installing it.
- After charging the refrigerant, check for leaks. Refer to [MTC-107, "Checking for Refrigerant Leaks"](#)

Removal and Installation for Refrigerant Pressure Sensor

EJS005PR

REMOVAL

1. Discharge the refrigerant. Refer to [MTC-92, "HFC-134a \(R-134a\) Service Procedure"](#) .
2. Remove the front grille. Refer to [EI-18, "FRONT GRILLE"](#) .
3. Reposition the LH air guide out of the way.
4. Disconnect the refrigerant pressure sensor connector (1) and remove the refrigerant pressure sensor (2) from the liquid tank (3).

CAUTION:

Do not damage the condenser fins.

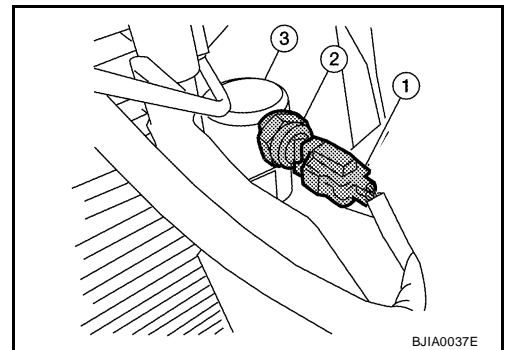

INSTALLATION

Installation is in the reverse order of removal.

CAUTION:

Replace the O-ring of the refrigerant pressure sensor with a new one, then apply compressor oil to it when installing it.

Removal and Installation for Condenser

EJS005PS

REMOVAL

1. Discharge the refrigerant. Refer to [MTC-92, "HFC-134a \(R-134a\) Service Procedure"](#) .
2. Remove the radiator. Refer to [CO-13, "RADIATOR"](#) .

A
B
C
D
E
F
G
H
I
K
L
M

MTC

REFRIGERANT LINES

CAUTION:

Be careful not to damage the core surface of the condenser and the radiator.

3. Disconnect the high-pressure flexible hose and the high-pressure pipe from the condenser.

CAUTION:

Cap or wrap the joint of the pipe and hose with suitable material such as vinyl tape to avoid the entry of contaminants.

4. Disconnect the refrigerant pressure sensor connector.
5. Remove the condenser bracket bolts.
6. Remove the condenser.

INSTALLATION

Installation is in the reverse order of removal.

CAUTION:

- Replace the O-rings of the high-pressure pipe, refrigerant pressure sensor, and high-pressure flexible hose with new ones, then apply A/C oil to them after installing them.
- When charging refrigerant, check for leaks. Refer to [MTC-107, "Checking for Refrigerant Leaks"](#).

Removal and Installation for Evaporator

EJS005PT

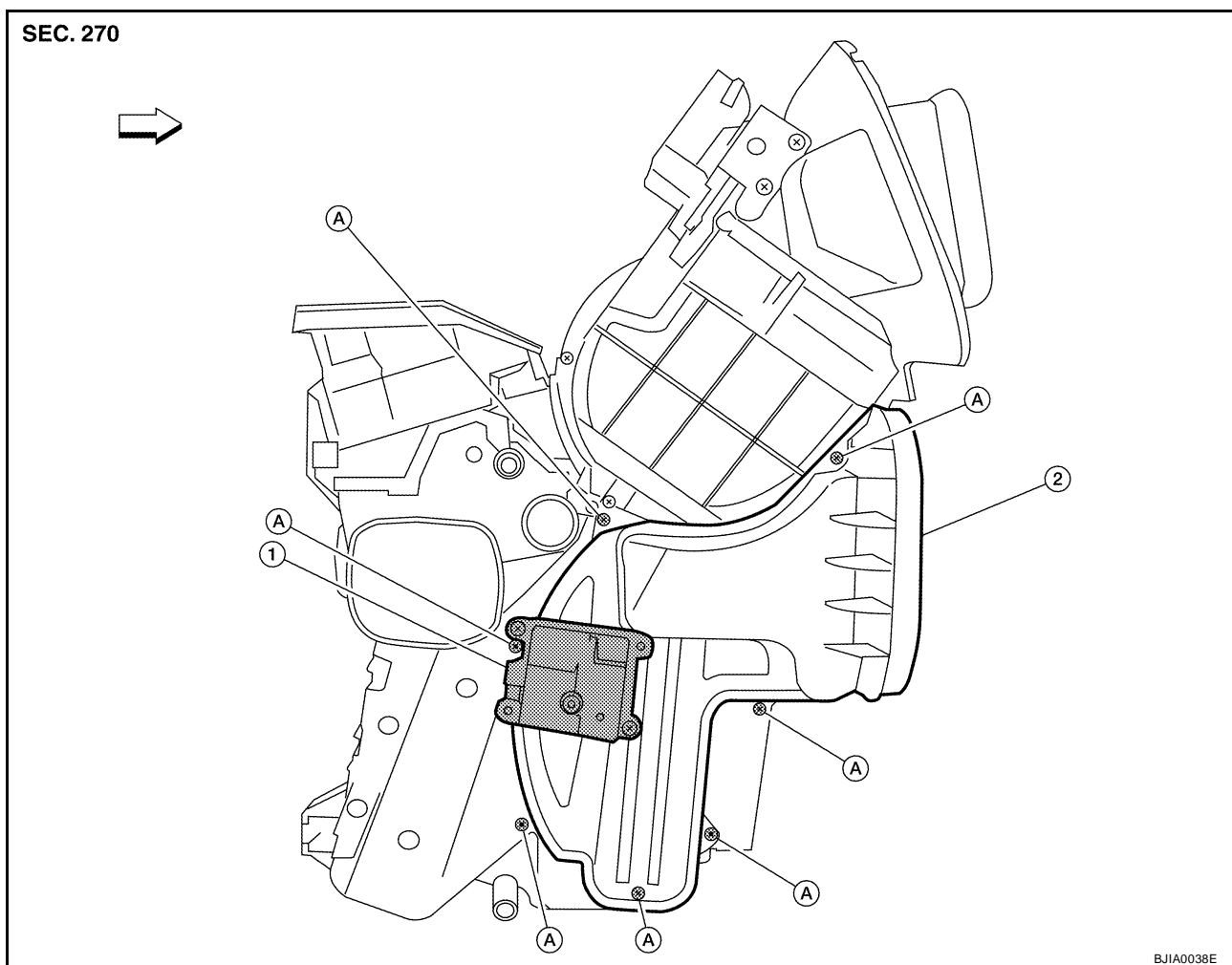

1. Air mix door motor

2. Evaporator cover

A. Screws

← Front

REMOVAL

1. Remove the expansion valve. Refer to [MTC-107, "Removal and Installation for Expansion Valve"](#).
2. Remove the instrument lower cover RH. Refer to [IP-10, "Component Parts"](#).
3. Remove the glove box. Refer to [IP-15, "GLOVE BOX ASSEMBLY"](#).

REFRIGERANT LINES

4. Remove the evaporator cover (1).
5. Remove the evaporator (2).

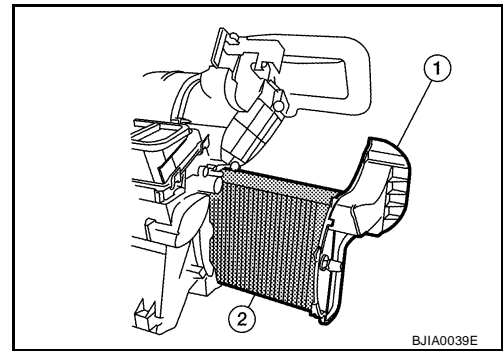

INSTALLATION

Installation is in the reverse order of removal.

CAUTION:

- Replace the O-rings with new ones, then apply compressor oil to them when installing them.

Removal and Installation for Expansion Valve

EJS005PU

REMOVAL

1. Evacuate and recover the A/C system refrigerant. Refer to [MTC-92, "HFC-134a \(R-134a\) Service Procedure"](#).
2. Reposition the lower dash insulator out of the way.
3. Disconnect the low-pressure flexible hose and the high-pressure pipe from the expansion valve.

CAUTION:

Cap or wrap the joint of the pipe and hose with suitable material such as vinyl tape to avoid the entry of contaminants.

4. Remove the expansion valve bolts (A) and then remove the expansion valve (1).

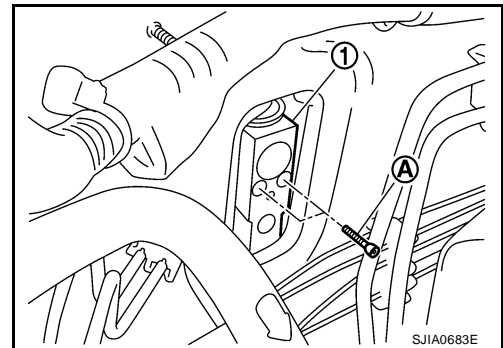

INSTALLATION

Installation is in the reverse order of removal.

Expansion valve bolts : 3.9 N-m (0.40 kg-m, 35 in-lb)

CAUTION:

- Replace the O-rings with new ones, then apply compressor oil to them when installing them.

Checking for Refrigerant Leaks

EJS005PV

Perform a visual inspection of all refrigeration parts, fittings, hoses and components for signs of A/C oil leakage, damage and corrosion. A/C oil leakage may indicate an area of refrigerant leakage. Allow extra inspection time in these areas when using either an electronic refrigerant leak detector or fluorescent dye leak detector.

If dye is observed, confirm the leak with an electronic refrigerant leak detector. It is possible a prior leak was repaired and not properly cleaned.

When searching for leaks, do not stop when one leak is found but continue to check for additional leaks at all system components and connections.

When searching for refrigerant leaks using an electronic leak detector, move the probe along the suspected leak area at 25 - 50 mm (1 - 2 in) per second and no further than 6 mm (1/4 in) from the component.

CAUTION:

Moving the electronic leak detector probe slower and closer to the suspected leak area will improve the chances of finding a leak.

REFRIGERANT LINES

Checking System for Leaks Using the Fluorescent Leak Detector

EJS005PW

1. Check A/C system for leaks using the UV lamp and safety goggles (J-42220) in a low sunlight area (area without windows preferable). Illuminate all components, fittings and lines. The dye will appear as a bright green/yellow area at the point of leakage. Fluorescent dye observed at the evaporator drain opening indicates an evaporator core assembly (tubes, core or expansion valve) leak.
2. If the suspected area is difficult to see, use an adjustable mirror or wipe the area with a clean shop rag or cloth, with the UV lamp for dye residue.
3. After the leak is repaired, remove any residual dye using refrigerant dye cleaner (J-43872) to prevent future misdiagnosis.
4. Perform a system performance check and verify the leak repair with an approved electronic refrigerant leak detector.

NOTE:

Other gases in the work area or substances on the A/C components, for example, anti-freeze, windshield washer fluid, solvents and oils, may falsely trigger the leak detector. Make sure the surfaces to be checked are clean.

Clean with a dry cloth or blow off with shop air.

Do not allow the sensor tip of the detector to contact with any substance. This can also cause false readings and may damage the detector.

Dye Injection

EJS005PX

NOTE:

This procedure is only necessary when recharging the A/C system or when the compressor has seized and has been replaced.

1. Check the A/C system static (at rest) pressure. Pressure must be at least 345 kPa (3.52 kg/cm², 50 psi).
2. Pour one bottle (1/4 ounce / 7.4 cc) of the A/C refrigerant dye into the injector tool (J-41459).

CAUTION:

If repairing the A/C system or replacing a component, pour the dye directly into the open system connection and proceed with the service procedures.

3. Connect the injector tool to the A/C LOW PRESSURE side service valve.
4. Start the engine and switch the A/C ON and fan ON.
5. While the A/C is operating (compressor running), inject one bottle (1/4 ounce / 7.4 cc) of fluorescent dye through the low-pressure service valve using dye injector tool (J-41459), refer to the manufacturer's operating instructions.
6. With the engine still running, disconnect the injector tool from the low-pressure service valve.
7. Operate the A/C system for a minimum of 20 minutes to mix the dye with the system oil. Depending on the leak size, operating conditions and location of the leak, it may take from a few minutes to a few days for the dye to penetrate the leak and become visible.

Electronic Refrigerant Leak Detector

EJS005PY

PRECAUTIONS FOR HANDLING THE LEAK DETECTOR

When performing a refrigerant leak check, use a electronic refrigerant leak detector (J-41995) or equivalent. Ensure that the instrument is calibrated and set properly per the manufacturer's operating instructions.

The leak detector is a delicate device. In order to use the leak detector properly, read the manufacturer's operating instructions and perform any specified maintenance.

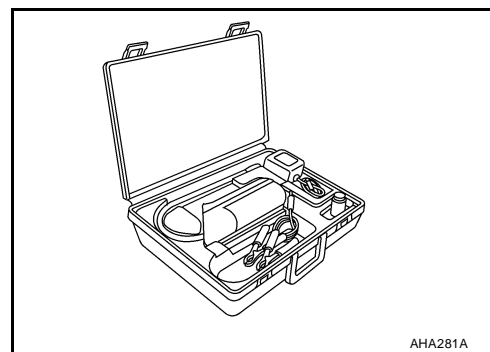

REFRIGERANT LINES

1. Position the leak detector probe approximately 5 mm (3/16 in) away from the point to be checked.

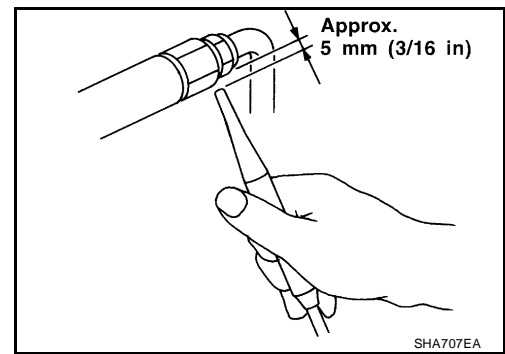

2. When testing, circle each fitting completely with the leak detector probe.

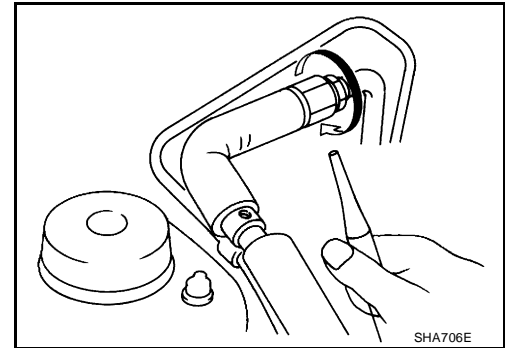

3. Move the leak detector probe along the component at approximately 25 to 50 mm (1 to 2 in)/sec.

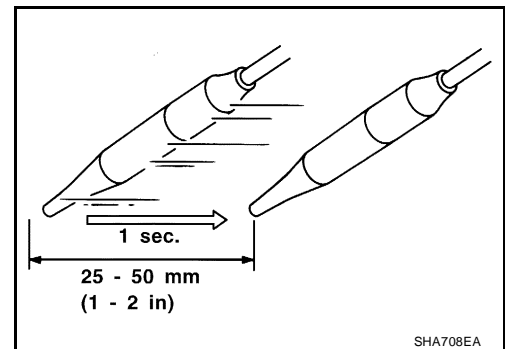

CHECKING PROCEDURE

NOTE:

To prevent inaccurate or false readings, make sure there is no refrigerant vapor, shop chemicals, or cigarette smoke in the vicinity of the vehicle. Perform the leak test in a calm area (low air/wind movement) so that the leaking refrigerant is not dispersed.

1. Turn engine OFF.
2. Connect a suitable A/C manifold gauge set to the A/C service ports.
3. Check if the A/C refrigerant pressure is at least 345 kPa (3.52 kg/cm², 50 psi) above 16°C (61°F). If less than specification, recover/evacuate and recharge the system with the specified amount of refrigerant.

NOTE:

At temperatures below 16°C (61°F), leaks may not be detected since the system may not reach 345 kPa (3.52 kg/cm², 50 psi) pressure.

4. Conduct the leak test from the high side (compressor discharge to evaporator inlet) to the low side (evaporator drain hose to the compressor shaft seal). Refer to [MTC-94, "Components"](#). Clean the component to be checked and move the leak detector probe completely around the connection/component.

Perform a leak check for the following areas:

- Compressor
- High and low-pressure hose fittings, relief valve and shaft seal.
- Liquid tank
- Refrigerant pressure sensor

A
B
C
D
E
F
G
H
I
MTC
K
L
M

REFRIGERANT LINES

- Service valves
 - Check that all the service valve caps are secure on the service valves (to prevent leaks).
 - After removing A/C manifold gauge set from service valves, wipe any residue from the valves to prevent any false readings by the leak detector.
 - Evaporator
 - With engine OFF, turn blower fan on “High” for at least 15 seconds to dissipate any refrigerant trace around the evaporator. Wait a minimum of 10 minutes accumulation time (refer to the manufacturer's recommended procedure for actual wait time) before inserting the leak detector probe into the drain hose.
 - Keep the probe inserted for at least 10 seconds. Use caution not to contaminate the probe tip with water or dirt that may be in the drain hose.
5. If a leak detector detects a leak, verify at least once by blowing compressed air into area of suspected leak, then repeat check as outlined above.
 6. Do not stop when one leak is found. Continue to check for additional leaks at all system components. If no leaks are found, perform steps 7 - 10.
 7. Start engine.
 8. Set the front air control as follows;
 - a. A/C switch: ON
 - b. Mode: Vent
 - c. Intake position: Recirculation
 - d. Temperature: MAX cold
 - e. Blower fan speed: High
 9. Run engine at 1,500 rpm for at least 2 minutes.

10. Turn engine off and perform leak check again following steps 4 through 6 above.

Refrigerant leaks should be checked immediately after stopping the engine. Begin with the leak detector at the compressor. The pressure on the high pressure side will gradually drop after refrigerant circulation stops and pressure on the low pressure side will gradually rise, as shown in the graph. Some leaks are more easily detected when pressure is high.

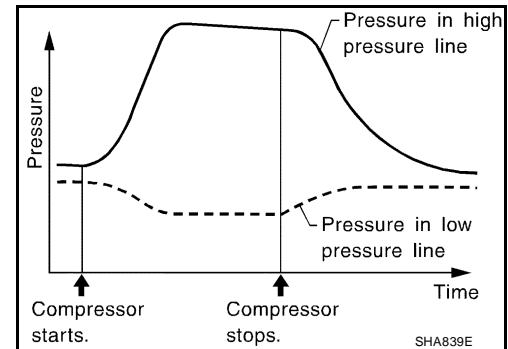

11. Before connecting the recovery/recycling equipment to the A/C system, check the recovery/recycling equipment gauges. No refrigerant pressure should be displayed. If pressure is displayed, recover the refrigerant from the equipment lines and then check the refrigerant purity.
12. Confirm the refrigerant purity in the supply tank using the recovery/recycling equipment and the refrigerant identifier equipment.
13. Confirm the refrigerant purity in the A/C system using the recovery/recycling equipment and the refrigerant identifier equipment.
14. Discharge the A/C system using approved refrigerant recovery/recycling equipment. Repair the leaking fitting or component as necessary.
15. Evacuate and recharge the A/C system and perform the leak test to confirm there are no refrigerant leaks.
16. Conduct the A/C performance test to ensure that the system works properly. Refer to [MTC-68, "PERFORMANCE TEST ANALYSIS"](#).

SERVICE DATA AND SPECIFICATIONS (SDS)

SERVICE DATA AND SPECIFICATIONS (SDS)

PFP:00030

Service Data and Specifications (SDS) COMPRESSOR

EJS005PZ

Model	Valeo
Type	DCS-171C
Displacement	171 cm ³ (10.43 in ³) / revolution
Cylinder bore × stroke	32 mm (1.260 in) x 30.5 mm (1.201 in)
Direction of rotation	Clockwise (viewed from drive end)
Drive belt	Poly V 6-grooves

OIL

Name	Genuine NISSAN A/C System Oil Type S	
Capacity	Total in system	150 mℓ (5.03 US fl oz, 5.3 Imp fl oz)
	Compressor (service part) charging amount	Refer to MTC-22, "Oil Adjustment Procedure for Compressor Replacement" .

REFRIGERANT

Type	HFC-134a (R-134a)
Capacity	0.50 ± 0.05 kg (1.10 ± 0.11 lb)

ENGINE IDLING SPEED

Refer to [EC-75, "Idle Speed and Ignition Timing Check"](#) .

BELT TENSION

Refer to [EM-15, "Tension Adjustment"](#) .

A

B

C

D

E

F

G

H

I

MTC

K

L

M

SERVICE DATA AND SPECIFICATIONS (SDS)
