

SECTION MA
MAINTENANCE

A
B
C

CONTENTS

<p>PRECAUTIONS 3</p> <p>Precautions for Supplemental Restraint System (SRS) "AIR BAG" and "SEAT BELT PRE-TENSIONER" 3</p> <p>PREPARATION 4</p> <p>Special Service Tools 4</p> <p>Commercial Service Tools 4</p> <p>GENERAL MAINTENANCE 6</p> <p>Explanation of General Maintenance 6</p> <p>General Maintenance 6</p> <p>PERIODIC MAINTENANCE 8</p> <p>Introduction of Periodic Maintenance 8</p> <p>Schedule 1 8</p> <p style="padding-left: 20px;">EMISSION CONTROL SYSTEM MAINTENANCE 8</p> <p style="padding-left: 20px;">CHASSIS AND BODY MAINTENANCE 10</p> <p>Schedule 2 11</p> <p style="padding-left: 20px;">EMISSION CONTROL SYSTEM MAINTENANCE 11</p> <p style="padding-left: 20px;">CHASSIS AND BODY MAINTENANCE 12</p> <p>RECOMMENDED FLUIDS AND LUBRICANTS 14</p> <p>MR20DE 14</p> <p>QR25DE 14</p> <p>SAE Viscosity Number 16</p> <p style="padding-left: 20px;">GASOLINE ENGINE OIL 16</p> <p style="padding-left: 20px;">Anti-freeze Coolant Mixture Ratio 16</p> <p>ENGINE MAINTENANCE (MR20DE) 17</p> <p>Drive Belts 17</p> <p>Checking Drive Belts 17</p> <p>Tension Adjustment 17</p> <p>Changing Engine Coolant 17</p> <p style="padding-left: 20px;">DRAINING ENGINE COOLANT 17</p> <p style="padding-left: 20px;">REFILLING ENGINE COOLANT 18</p> <p style="padding-left: 20px;">FLUSHING COOLING SYSTEM 19</p> <p>Inspection 19</p> <p style="padding-left: 20px;">LEVEL CHECK 19</p> <p style="padding-left: 20px;">CHECKING COOLING SYSTEM FOR LEAKS... 19</p> <p>Checking Fuel Lines 20</p> <p>Changing Air Cleaner Filter 20</p>	<p>REMOVAL 20</p> <p>INSPECTION AFTER REMOVAL 20</p> <p>INSTALLATION 20</p> <p>Engine Oil Level 20</p> <p>INSPECTION 20</p> <p>ENGINE OIL APPEARANCE 20</p> <p>ENGINE OIL LEAKAGE 21</p> <p>OIL PRESSURE CHECK 21</p> <p>Changing Engine Oil 22</p> <p>Engine Oil Filter 23</p> <p style="padding-left: 20px;">REMOVAL 23</p> <p style="padding-left: 20px;">INSTALLATION 23</p> <p style="padding-left: 20px;">INSPECTION AFTER INSTALLATION 23</p> <p>Changing Spark Plugs 23</p> <p style="padding-left: 20px;">INSPECTION AFTER REMOVAL 24</p> <p style="padding-left: 20px;">INSTALLATION 24</p> <p>Checking EVAP Vapor Lines 25</p> <p>ENGINE MAINTENANCE (QR25DE ENGINE) 26</p> <p>Checking Drive Belts 26</p> <p>Tension Adjustment 26</p> <p>Changing Engine Coolant 26</p> <p style="padding-left: 20px;">DRAINING ENGINE COOLANT 26</p> <p style="padding-left: 20px;">REFILLING ENGINE COOLANT 27</p> <p style="padding-left: 20px;">FLUSHING COOLING SYSTEM 28</p> <p>Checking Fuel Lines 28</p> <p>Changing Air Cleaner Filter 28</p> <p style="padding-left: 20px;">CHANGING THE AIR CLEANER ELEMENT 29</p> <p>Engine Oil 29</p> <p style="padding-left: 20px;">OIL LEVEL 29</p> <p style="padding-left: 20px;">ENGINE OIL APPEARANCE 29</p> <p style="padding-left: 20px;">OIL LEAKAGE 29</p> <p>Changing Engine Oil 29</p> <p>Changing Oil Filter 30</p> <p style="padding-left: 20px;">REMOVAL 30</p> <p style="padding-left: 20px;">INSTALLATION 30</p> <p>Changing Spark Plugs 31</p> <p style="padding-left: 20px;">REMOVAL 31</p> <p style="padding-left: 20px;">INSPECTION AFTER REMOVAL 32</p>
---	---

D
E
F
G
H
I
J
K

MA

M

INSTALLATION	32	OIL LEAKAGE AND OIL LEVEL	37
Checking EVAP Vapor Lines	32	Balancing Wheels	37
CHASSIS AND BODY MAINTENANCE	33	REMOVAL	37
Changing In-cabin Microfilter	33	WHEEL BALANCE ADJUSTMENT	38
Checking Exhaust System	34	Rotation	39
Checking CVT Fluid	34	Checking Brake Fluid Level and Leaks	39
FLUID LEVEL CHECK	34	Checking Brake Lines and Cables	40
FLUID CONDITION CHECK	35	Changing Brake Fluid	40
Changing CVT Fluid	35	Checking Disc Brake	41
Checking Clutch Fluid Level and Leaks	36	ROTOR	41
Checking Clutch System	36	CALIPER	41
Changing M/T Oil - RS6F94R	36	PAD	41
DRAINING	36	WHEEL CYLINDER	41
FILLING	36	LINING	42
Checking M/T Oil - RS6F94R	36	Axle and Suspension Parts	42
OIL LEAKAGE AND OIL LEVEL	36	Drive Shaft	42
Changing M/T Oil - RS6F52A and RS6F52H	37	Lubricating Locks, Hinges and Hood Latch	43
DRAINING	37	Checking Seat Belts, Buckles, Retractors, Anchors	
FILLING	37	and Adjusters	43
Checking M/T Oil - RS6F52A and RS6F52H	37		

PRECAUTIONS

PRECAUTIONS

PFP:00001

Precautions for Supplemental Restraint System (SRS) “AIR BAG” and “SEAT BELT PRE-TENSIONER”

ELS002A1

The Supplemental Restraint System such as “AIR BAG” and “SEAT BELT PRE-TENSIONER”, used along with a front seat belt, helps to reduce the risk or severity of injury to the driver and front passenger for certain types of collision. Information necessary to service the system safely is included in the SRS and SB section of this Service Manual.

WARNING:

- To avoid rendering the SRS inoperative, which could increase the risk of personal injury or death in the event of a collision which would result in air bag inflation, all maintenance must be performed by an authorized NISSAN/INFINITI dealer.
- Improper maintenance, including incorrect removal and installation of the SRS, can lead to personal injury caused by unintentional activation of the system. For removal of Spiral Cable and Air Bag Module, see the SRS section.
- Do not use electrical test equipment on any circuit related to the SRS unless instructed to in this Service Manual. SRS wiring harnesses can be identified by yellow and/or orange harnesses or harness connectors.

A
B
C
D
E
F
G
H
I
J
K
MA
M

MA

PREPARATION

PREPARATION

PF0:00002

Special Service Tools

ELS002A2

The actual shapes of Kent-Moore tools may differ from those of special service tools illustrated here.

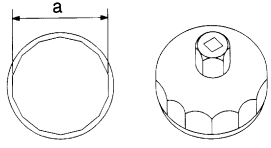
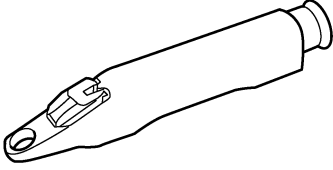
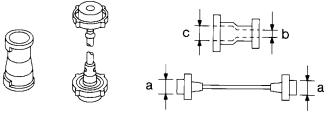
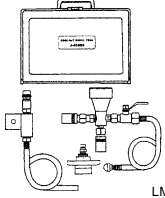
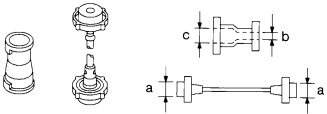
Tool number (Kent-Moore No.) Tool name	Description
KV10115801 (J-38956) Oil filter wrench <div style="text-align: center;">  <p>S-NT375</p> </div>	Removing and installing oil filter a: 64.3 mm (2.531 in)
KV991J0010 (J-23688) Engine coolant refractometer <div style="text-align: center;">  <p>WBIA0539E</p> </div>	Checking concentration of ethylene glycol in engine coolant
EG17650301 (J-33984-A) Radiator cap tester adapter <div style="text-align: center;">  <p>S-NT564</p> </div>	Adapting radiator cap tester to radiator cap and radiator filler neck a: 28 (1.10) dia. b: 31.4 (1.236) dia. c: 41.3 (1.626) dia. Unit: mm (in)
KV991J0070 (J-45695) Coolant Refill Tool <div style="text-align: center;">  <p>LMA053</p> </div>	Refilling engine cooling system
EG17650301 (J-33984-A) Radiator cap tester adapter <div style="text-align: center;">  <p>S-NT564</p> </div>	Adapting radiator cap tester to radiator cap and radiator filler neck a: 28 (1.10) dia. b: 31.4 (1.236) dia. c: 41.3 (1.626) dia. Unit: mm (in)

Commercial Service Tools

ELS002A3

PREPARATION

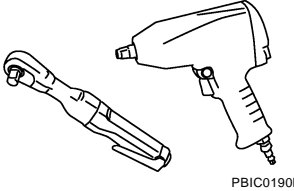
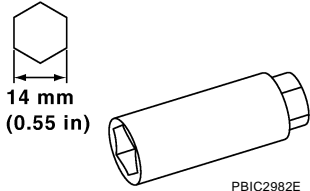
(Kent-Moore No.) Tool name	Description
Power tool  <p style="text-align: right; margin-right: 50px;">PBIC0190E</p>	Loosening bolts and nuts
Spark plug wrench  <p style="text-align: center; margin-right: 50px;">14 mm (0.55 in)</p> <p style="text-align: right; margin-right: 50px;">PBIC2982E</p>	Removing and installing spark plug

A
B
C
D
E
F
G
H
I
J
K
M

MA

GENERAL MAINTENANCE

GENERAL MAINTENANCE

PFP:00000

Explanation of General Maintenance

ELS002A4

General Maintenance

ELS002A5

General maintenance includes those items which should be checked during the normal day-to-day operation of the vehicle. They are essential if the vehicle is to continue operating properly. The owners can perform checks and inspections themselves or they can have their NISSAN dealers do them.

OUTSIDE THE VEHICLE

The maintenance items listed here should be performed from time to time, unless otherwise specified.

Item		Reference page
Tires	Check the pressure including the spare, at least once a month and always prior to a long distance trip. Adjust to the specified pressure if necessary. Check carefully for damage, cuts or excessive wear.	WT-29, "Tire"
Wheel nuts	When checking the tires, make sure no nuts are missing, and check for any loose nuts. Tighten if necessary.	WT-8, "Rotation"
Windshield	Clean the windshield on a regular basis. Check the windshield at least every six months for cracks or other damage. Repair as necessary.	—
Tire rotation	Tires should be rotated every 12,000 km (7,500 miles).	WT-8, "Rotation"
Component parts of tire pressure monitoring system (TPMS)	Replace grommet seal, valve core and cap of the transmitter in TPMS every tire replacement when reaching wear limit of tire.	WT-27, "Transmitter (Pressure Sensor)"
Wheel alignment and balance	If the vehicle pulls to either side while driving on a straight and level road, or if you detect uneven or abnormal tire wear, there may be a need for wheel alignment. If the steering wheel or seat vibrates at normal highway speeds, wheel balancing may be needed.	FSU-19, "Wheel Alignment (Unladen*)" and MA-37, "Balancing Wheels"
Windshield wiper blades	Check for cracks or wear if they do not wipe properly.	—
Doors and engine hood	Check that all doors and the engine hood operate smoothly as well as the trunk lid and back hatch. Also make sure that all latches lock securely. Lubricate if necessary. Make sure that the secondary latch keeps the hood from opening when the primary latch is released. When driving in areas using road salt or other corrosive materials, check lubrication frequently.	MA-43, "Lubricating Locks, Hinges and Hood Latch"
Lamps	Make sure that the headlamps, stop lamps, tail lamps, turn signal lamps, and other lamps are all operating properly and installed securely. Also check headlamp aim. Clean the headlamps on a regular basis.	—

INSIDE THE VEHICLE

The maintenance items listed here should be checked on a regular basis, such as when performing periodic maintenance, cleaning the vehicle, etc.

Item		Reference page
Warning lamps and buzzers/chimes	Make sure that all warning lamps and buzzers/chimes are operating properly.	—
Windshield wiper and washer	Check that the wipers and washer operate properly and that the wipers do not streak.	—
Windshield defroster	Check that the air comes out of the defroster outlets properly and in sufficient quantity when operating the heater or air conditioning.	—
Steering wheel	Check that it has the specified play. Be sure to check for changes in the steering condition, such as excessive play, hard steering or strange noises. Free play: Less than 35 mm (1.38 in)	—
Seats	Check seat position controls such as seat adjusters, seat back recliner, etc. to make sure they operate smoothly and that all latches lock securely in every position. Check that the head restraints move up and down smoothly and that the locks (if equipped) hold securely in all latched positions. Check that the latches lock securely for folding-down rear seat backs.	—

GENERAL MAINTENANCE

Item		Reference page
Seat belts	Check that all parts of the seat belt system (e.g. buckles, anchors, adjusters and retractors) operate properly and smoothly and are installed securely. Check the belt webbing for cuts, fraying, wear or damage.	SB-8, "Seat Belt Inspection"
Accelerator pedal	Check the pedal for smooth operation and make sure the pedal does not catch or require uneven effort. Keep the floor mats away from the pedal.	—
Clutch pedal	Make sure the pedal operates smoothly and check that it has the proper free play.	MA-36
Brakes	Check that the brake does not pull the vehicle to one side when applied.	—
Brake pedal and booster	Check the pedal for smooth operation and make sure it has the proper distance under it when depressed fully. Check the brake booster function. Be sure to keep floor mats away from the pedal.	MA-39 and MA-40
Parking brake	Check that the lever has the proper travel and make sure that the vehicle is held securely on a fairly steep hill when only the parking brake is applied.	PB-4
CVT P (Park) position mechanism	On a fairly steep hill check that the vehicle is held securely with the selector lever in the "P" position without applying any brakes.	—

UNDER THE HOOD AND VEHICLE

The maintenance items listed here should be checked periodically (e.g. each time you check the engine oil or refuel).

Item		Reference page
Windshield washer fluid	Check that there is adequate fluid in the tank.	—
Engine coolant level	Check the coolant level when the engine is cold.	MA-19
A/C condenser, radiator and hoses	Check the front of the condenser and radiator and clean off any dirt, insects, leaves, etc., that may have accumulated. Make sure the radiator hoses have no cracks, deformation, deterioration or loose connections.	—
Brake and clutch fluid levels	Make sure that the brake and clutch fluid levels are between the "MAX" and "MIN" lines on the reservoirs.	MA-39 and MA-36
Battery	Check the fluid level in each cell. It should be between the "MAX" and "MIN" lines. Vehicles operated in high temperatures or under severe conditions require frequent checks of the battery fluid level.	—
Engine drive belts	Make sure that no belt is frayed, worn, cracked or oily.	MA-17
Engine oil level	Check the level on the dipstick after parking the vehicle on a level spot and turning off the engine.	MA-22
Automatic transaxle fluid level	Check the level on the dipstick after putting the selector lever in "P" with the engine idling.	MA-34
Exhaust system	Make sure there are no loose supports, cracks or holes. If the sound of the exhaust seems unusual or there is a smell of exhaust fumes, immediately locate the trouble and correct it.	MA-34
Underbody	The underbody is frequently exposed to corrosive substances such as those used on icy roads or to control dust. It is very important to remove these substances, otherwise rust will form on the floor pan, frame, fuel lines and around the exhaust system. At the end of winter, the underbody should be thoroughly flushed with plain water, being careful to clean those areas where mud and dirt can easily accumulate.	—
Fluid leaks	Check under the vehicle for fuel, oil, water or other fluid leaks after the vehicle has been parked for a while. Water dripping from the air conditioner after use is normal. If you should notice any leaks or gasoline fumes are evident, check for the cause and correct it immediately.	—

PERIODIC MAINTENANCE

PERIODIC MAINTENANCE

PFP:00026

Introduction of Periodic Maintenance

ELS002A6

Two different maintenance schedules are provided, and should be used, depending upon the conditions in which the vehicle is mainly operated. **After 60,000 miles (96,000 km) or 48 months, continue the periodic maintenance at the same mileage/time intervals.**

Schedule 1	Follow Periodic Maintenance Schedule 1 if your driving habits frequently includes one or more of the following driving conditions: <ul style="list-style-type: none"> ● Repeated short trips of less than 5 miles (8 km). ● Repeated short trips of less than 10 miles (16 km) with outside temperatures remaining below freezing. ● Operating in hot weather in stop-and-go “rush hour” traffic. ● Extensive idling and/or low speed driving for long distances, such as police, taxi or door-to-door delivery use. ● Driving in dusty conditions. ● Driving on rough, muddy, or salt spread roads. ● Towing a trailer, using a camper or a car-top carrier. 	Emission Control System Maintenance	MA-8
		Chassis and Body Maintenance	MA-10
Schedule 2	Follow Periodic Maintenance Schedule 2 if none of the driving conditions shown in Schedule 1 apply to your driving habits.	Emission Control System Maintenance	MA-11
		Chassis and Body Maintenance	MA-12

Schedule 1

EMISSION CONTROL SYSTEM MAINTENANCE

ELS002A7

Abbreviations: R = Replace. I = Inspect. Correct or replace if necessary. []: At the mileage intervals only

MAINTENANCE OPERATION		MAINTENANCE INTERVAL								Reference Section - Page or - Content Title
Perform at number of miles, kilometers or months, whichever comes first.	Miles x 1,000 (km x 1,000) Months	3.75 (6) 3	7.5 (12) 6	11.25 (18) 9	15 (24) 12	18.75 (30) 15	22.5 (36) 18	26.25 (42) 21	30 (48) 24	
Drive belt	NOTE (1)									MA-17 (MR) MA-26 (QR)
Air cleaner filter	NOTE (2)								R	MA-20 (MR) MA-28 (QR)
EVAP vapor lines									I*	MA-25 (MR) MA-32 (QR)
Fuel lines									I*	MA-20 (MR) MA-28 (QR)
Fuel filter	NOTE (3)									—
Engine coolant	NOTE (4)									MA-17 (MR) MA-26 (QR)
Engine oil		R	R	R	R	R	R	R	R	MA-22 (MR) MA-29 (QR)

PERIODIC MAINTENANCE

MAINTENANCE OPERATION		MAINTENANCE INTERVAL								Reference Section - Page or - Content Title
Perform at number of miles, kilometers or months, whichever comes first.	Miles x 1,000 (km x 1,000) Months	3.75 (6) 3	7.5 (12) 6	11.25 (18) 9	15 (24) 12	18.75 (30) 15	22.5 (36) 18	26.25 (42) 21	30 (48) 24	
Engine oil filter (Use genuine oil filter or equivalent)		R	R	R	R	R	R	R	R	MA-23 (MR) MA-30 (QR)
Spark plugs (Platinum-tipped type)		Replace every 105,000 miles (169,000 km)								MA-23 (MR) MA-31 (QR)
Intake and exhaust valve clearance	NOTE (5)									EM-108 (MR) EM-209 (QR)

Abbreviations: R = Replace. I = Inspect. Correct or replace if necessary. []: At the mileage intervals only

MAINTENANCE OPERATION		MAINTENANCE INTERVAL								Reference Section - Page or - Content Title
Perform at number of miles, kilometers or months, whichever comes first.	Miles x 1,000 (km x 1,000) Months	33.75 (54) 27	37.5 (60) 30	41.25 (66) 33	45 (72) 36	48.75 (78) 39	52.5 (84) 42	56.25 (90) 45	60 (96) 48	
Drive belt	NOTE (1)								I*	MA-17 (MR) MA-26 (QR)
Air cleaner filter	NOTE (2)								R	MA-20 (MR) MA-28 (QR)
EVAP vapor lines									I*	MA-25 (MR) MA-32 (QR)
Fuel lines									I*	MA-20 (MR) MA-28 (QR)
Fuel filter	NOTE (3)									—
Engine coolant	NOTE (4)								R*	MA-17 (MR) MA-26 (QR)
Engine oil		R	R	R	R	R	R	R	R	MA-22 (MR) MA-29 (QR)
Engine oil filter (Use genuine oil filter or equivalent)		R	R	R	R	R	R	R	R	MA-23 (MR) MA-30 (QR)

PERIODIC MAINTENANCE

MAINTENANCE OPERATION		MAINTENANCE INTERVAL								Reference Section - Page or - Content Title
Perform at number of miles, kilometers or months, whichever comes first.	Miles x 1,000 (km x 1,000) Months	33.75 (54) 27	37.5 (60) 30	41.25 (66) 33	45 (72) 36	48.75 (78) 39	52.5 (84) 42	56.25 (90) 45	60 (96) 48	
Spark plugs (Platinum-tipped type)		Replace every 105,000 miles (169,000 km)								MA-23 (MR) MA-31 (QR)
Intake and exhaust valve clearance	NOTE (5)									EM-108 (MR) EM-209 (QR)

- (1) After 60,000 miles (96,000 km) or 48 months, inspect every 15,000 miles (24,000 km) or 12 months. Replace the drive belts if found damaged or if the auto belt tensioner reading reaches the maximum limit.
- (2) If operating mainly in dusty conditions, more frequent maintenance may be required.
- (3) Maintenance-free item. For service procedures, go to the FL section.
- (4) After 60,000 miles (96,000 km) or 48 months, replace every 30,000 miles (48,000 km) or 24 months.
- (5) If valve noise increases, inspect valve clearance.

* Maintenance items and intervals with "*" are recommended by NISSAN for reliable vehicle operation. The owner need not perform such maintenance in order to maintain the emission warranty or manufacturer recall liability. Other maintenance items and intervals are required.

CHASSIS AND BODY MAINTENANCE

Abbreviations: R = Replace. I = Inspect. Correct or replace if necessary. L = Lubricate.

MAINTENANCE OPERATION		MAINTENANCE INTERVAL								Reference Section - Page or - Content Title
Perform at number of miles, kilometers or months, whichever comes first.	Miles x 1,000 (km x 1,000) Months	3.75 (6) 3	7.5 (12) 6	11.25 (18) 9	15 (24) 12	18.75 (30) 15	22.5 (36) 18	26.25 (42) 21	30 (48) 24	
Brake lines & cables					I				I	MA-40
Brake pads, rotors, drums & linings			I		I		I		I	MA-41
Manual transaxle oil	NOTE (1)				I				I	MA-36 (RS6F94R) MA-37 (RS6F52A and RS6F52H)
CVT fluid	NOTE (2)				I				I	MA-34
Steering gear & linkage, axle & suspension parts			I		I		I		I	MA-42 , MA-42
Tire rotation	NOTE (3)									MA-39
Front drive shaft boots			I		I		I		I	MA-42
Exhaust system			I		I		I		I	MA-34
In-cabin microfilter					R				R	MA-33

PERIODIC MAINTENANCE

Abbreviations: R = Replace. I = Inspect. Correct or replace if necessary. L = Lubricate.

MAINTENANCE OPERATION		MAINTENANCE INTERVAL								Reference Section - Page or - Content Title
Perform at number of miles, kilometers or months, whichever comes first.	Miles x 1,000 (km x 1,000) Months	33.75 (54) 27	37.5 (60) 30	41.25 (66) 33	45 (72) 36	48.75 (78) 39	52.5 (84) 42	56.25 (90) 45	60 (96) 48	
Brake lines & cables					I				I	MA-40
Brake pads, rotors, drums & linings			I		I		I		I	MA-41
Manual transaxle oil	NOTE (1)				I				I	MA-36 (RS6F94R) MA-37 (RS6F52A and RS6F52H)
CVT fluid	NOTE (2)				I					MA-34
Steering gear & linkage, axle & suspension parts			I		I		I		I	MA-42 , MA-42
Tire rotation	NOTE (3)									MA-39
Front drive shaft boots			I		I		I		I	MA-42
Exhaust system			I		I		I		I	MA-34
In-cabin microfilter					R				R	MA-33

(1) If towing a trailer, using a camper or a car-top carrier, or driving on rough or muddy roads, change (not just inspect) oil at every 30,000 miles (48,000 km) or 24 months.

(2) If towing a trailer, using a camper or a car-top carrier, or driving on rough or muddy roads, inspect CVT fluid deterioration with CONSULT-III every 60,000 miles (96,000 km), then change CVT fluid NS-2 if necessary. (Refer to CVT section). If CONSULT-III is not available, change (not just inspect) CVT fluid NS-2 every 60,000 miles (96,000 km). **Using transmission fluid other than Genuine NISSAN CVT Fluid NS-2 will damage the CVT, which is not covered by the NISSAN new vehicle limited warranty.**

(3) Refer to "Tire rotation" under the "GENERAL MAINTENANCE" heading earlier in this section.

Schedule 2 EMISSION CONTROL SYSTEM MAINTENANCE

ELS002A8

Abbreviations: R = Replace. I = Inspect. Correct or replace if necessary. []: At the mileage intervals only

MAINTENANCE OPERATION		MAINTENANCE INTERVAL								Reference Section - Page or - Content Title
Perform at number of miles, kilometers or months, whichever comes first.	Miles x 1,000 (km x 1,000) Months	7.5 (12) 6	15 (24) 12	22.5 (36) 18	30 (48) 24	37.5 (60) 30	45 (72) 36	52.5 (84) 42	60 (96) 48	
Drive belt	NOTE (1)								I*	MA-17 (MR) MA-26 (QR)
Air cleaner filter					[R]				[R]	MA-20 (MR) MA-28 (QR)
EVAP vapor lines					I*				I*	MA-25 (MR) MA-32 (QR)
Fuel lines					I*				I*	MA-20 (MR) MA-28 (QR)
Fuel filter	NOTE (2)									—

PERIODIC MAINTENANCE

MAINTENANCE OPERATION		MAINTENANCE INTERVAL								Reference Section - Page or - Content Title	
Perform at number of miles, kilometers or months, whichever comes first.	Miles x 1,000 (km x 1,000) Months	7.5 (12) 6	15 (24) 12	22.5 (36) 18	30 (48) 24	37.5 (60) 30	45 (72) 36	52.5 (84) 42	60 (96) 48		
Engine coolant	NOTE (3)									R*	MA-17 (MR) MA-26 (QR)
Engine oil		R	R	R	R	R	R	R	R	R	MA-22 (MR) MA-29 (QR)
Engine oil filter (Use genuine oil filter or equivalent.)		R	R	R	R	R	R	R	R	R	MA-23 (MR) MA-30 (QR)
Spark plugs (Platinum-tipped type)		Replace every 105,000 miles (169,000 km)									MA-23 (MR) MA-31 (QR)
Intake and exhaust valve clearance)	NOTE (4)										EM-108 (MR) EM-209 (QR)

(1) After 60,000 miles (96,000 km) or 48 months, inspect every 15,000 miles (24,000 km) or 12 months. Replace the drive belt if found damaged or if the auto belt tensioner reading reaches the maximum limit.

(2) Maintenance-free item.

(3) After 60,000 miles (96,000 km) or 48 months, replace every 30,000 miles (48,000 km) or 24 months.

(4) If valve noise increases, inspect valve clearance.

Maintenance items and intervals with “*” are recommended by NISSAN for reliable vehicle operation. The owner need not perform such maintenance in order to maintain the emission warranty or manufacturer recall liability. Other maintenance items and intervals are required.

CHASSIS AND BODY MAINTENANCE

Abbreviations: R = Replace. I = Inspect. Correct or replace if necessary. L = Lubricate.

MAINTENANCE OPERATION		MAINTENANCE INTERVAL								Reference Section - Page or - Content Title
Perform at number of miles, kilometers or months, whichever comes first.	Miles x 1,000 (km x 1,000) Months	7.5 (12) 6	15 (24) 12	22.5 (36) 18	30 (48) 24	37.5 (60) 30	45 (72) 36	52.5 (84) 42	60 (96) 48	
Brake lines & cables			I		I		I		I	MA-40
Brake pads, rotors, drums & linings			I		I		I		I	MA-41
Manual transaxle oil			I		I		I		I	MA-36 (RS6F94R) MA-37 (RS6F52A and RS6F52H)
CVT fluid	NOTE (1)		I		I		I		I	MA-34
Steering gear & linkage, axle & suspension parts					I				I	MA-42 , MA-42
Tire rotation	NOTE (2)									MA-39
Front drive shaft boots			I		I		I		I	MA-42
Exhaust system					I				I	MA-34
In-cabin microfilter			R		R		R		R	MA-33

(1) Using transmission fluid other than Genuine NISSAN CVT Fluid NS-2 will damage the CVT, which is not covered by the NISSAN new vehicle limited warranty.

PERIODIC MAINTENANCE

(2) Refer to "Tire rotation" under the "GENERAL MAINTENANCE" heading earlier in this section.

A

B

C

D

E

F

G

H

I

J

K

MA

M

RECOMMENDED FLUIDS AND LUBRICANTS

RECOMMENDED FLUIDS AND LUBRICANTS

PF0:0000

MR20DE

ELS002A9

Description		Capacity (Approximate)			Recommended Fluids/Lubricants
		Liter	US measure	Imp measure	
Fuel		55.0	14 1/2 gal	12 1/8 gal	Unleaded gasoline with an octane rating of at least 87 AKI (RON 91)
Engine oil Drain and refill	With oil filter change	3.8	4 qt	3 3/8 qt	● API Certification Mark *1
	Without oil filter change	3.6	3 7/8 qt	3 1/8 qt	
Dry engine (engine overhaul)		4.4	4 5/8 qt	3 7/8 qt	
Cooling system (with reservoir at max level)		7.0	1 7/8 gal	1 1/2 gal	Genuine NISSAN Long Life Anti-freeze Coolant or equivalent
Manual transaxle fluid (MTF)		2.0	4 1/4 pt	3 1/2 pt	ELF XT4447 M+ 75W-80 or API GL-4, Viscosity SAE 75W-80
CVT fluid		8.3	8 3/4 qt	7 1/4 qt	Genuine NISSAN CVT Fluid NS-2 *2
Brake and clutch fluid		—	—	—	Genuine NISSAN Super Heavy Duty Brake Fluid*3 or equivalent DOT 3 (US FMVSS No. 116)
Multi-purpose grease		—	—	—	NLGI No. 2 (Lithium soap base)
Windshield washer fluid		3.5	3 3/4 qt	3 1/8 qt	Genuine NISSAN Windshield Washer Concentrate Cleaner & Anti-Freeze or equivalent
Air conditioning system refrigerant		0.50 ± 0.05 kg	1.10 ± 0.11 lb	1.10 ± 0.11 lb	HFC-134a (R-134a) *4
Air conditioning system oil		120 mℓ	5.03 fl oz	5.3 fl oz	NISSAN A/C System Lubricant Type S or equivalent *4

*1: For further details, see "SAE Viscosity Number".

*2: **Using transaxle fluid other than Genuine NISSAN CVT Fluid NS-2 will damage the CVT, which is not covered by the NISSAN new vehicle limited warranty.**

*3: Available in mainland U.S.A. through your NISSAN dealer.

*4: For further details, see "Air conditioner specification label".

QR25DE

ELS002DP

Description		Capacity (Approximate)			Recommended Fluids/Lubricants
		Liter	US measure	Imp measure	
Fuel		55.0	14 1/2 gal	12 1/8 gal	Unleaded gasoline with an octane rating of at least 87 AKI (RON 91)
Engine oil Drain and refill	With oil filter change	4.9	5 1/8 qt	4 3/8 qt	● API Certification Mark *1
	Without oil filter change	4.6	4 7/8 qt	4 qt	
Dry engine (engine overhaul)		5.0	5 1/4 qt	4 3/8 qt	
Cooling system (with reservoir at max level)		7.6	2 gal	1 5/8 gal	Genuine NISSAN Long Life Anti-freeze / Coolant or equivalent
Manual transaxle fluid (MTF)		2.0	4 1/4 pt	3 1/2 pt	ELF XT4447 M+ 75W-80 or API GL-4, Viscosity SAE 75W-80
CVT fluid		8.3	8 3/4 qt	7 1/4 qt	Genuine NISSAN CVT Fluid NS-2 *2
Brake and clutch fluids		—	—	—	Genuine NISSAN Super Heavy Duty Brake Fluid or equivalent, DOT 3 (US FMVSS No. 116) *3
Multi-purpose grease		—	—	—	NLGI No. 2 (Lithium soap base)

RECOMMENDED FLUIDS AND LUBRICANTS

Description	Capacity (Approximate)			Recommended Fluids/Lubricants
	Liter	US measure	Imp measure	
Windshield washer fluid	3.5	3 3/4 qt	3 1/8 qt	Genuine NISSAN Windshield Washer Concentrate Cleaner & Anti-freeze or equivalent
Air conditioning system refrigerant	0.50 ± 0.05 kg	1.10 ± 0.11 lb	1.10 ± 0.11 lb	HFC-134a (R-134a) *4
Air conditioning system oil	120 m ℓ	5.03 fl oz	5.3 fl oz	NISSAN A/C System Lubricant Type S or equivalent *4

*1: For further details, see "SAE Viscosity Number".

*2: **Using transaxle fluid other than Genuine NISSAN CVT Fluid NS-2 will damage the CVT, which is not covered by the NISSAN new vehicle limited warranty.**

*3: Available in mainland U.S.A. through your NISSAN dealer.

*4: For further details, see "Air conditioner specification label".

A
B
C
D
E
F
G
H
I
J
K
M

MA

RECOMMENDED FLUIDS AND LUBRICANTS

SAE Viscosity Number GASOLINE ENGINE OIL

ELS002AA

SAE 5W-30 viscosity oil is recommended for all temperatures.

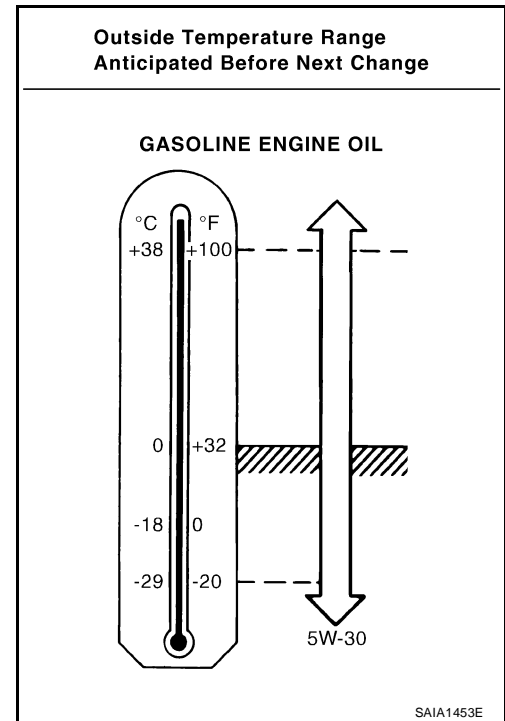

Anti-freeze Coolant Mixture Ratio

ELS002AB

The engine cooling system is filled at the factory with a high-quality, long life, year-round, anti-freeze coolant solution. The anti-freeze solution contains rust and corrosion inhibitors. Therefore, additional cooling system additives are not necessary.

Maximum outside temperature		Genuine NISSAN Anti-freeze Coolant or equivalent	Demineralized water or distilled water
°C	°F		
-35	-30	50%	50%

CAUTION:

- When adding or replacing coolant, be sure to use only a Genuine NISSAN Long Life Anti-Freeze coolant or equivalent with the proper mixture ratio.
- The use of other types of coolant solutions may damage the engine cooling system.

ENGINE MAINTENANCE (MR20DE)

PFP:00100

Drive Belts

ELS002CF

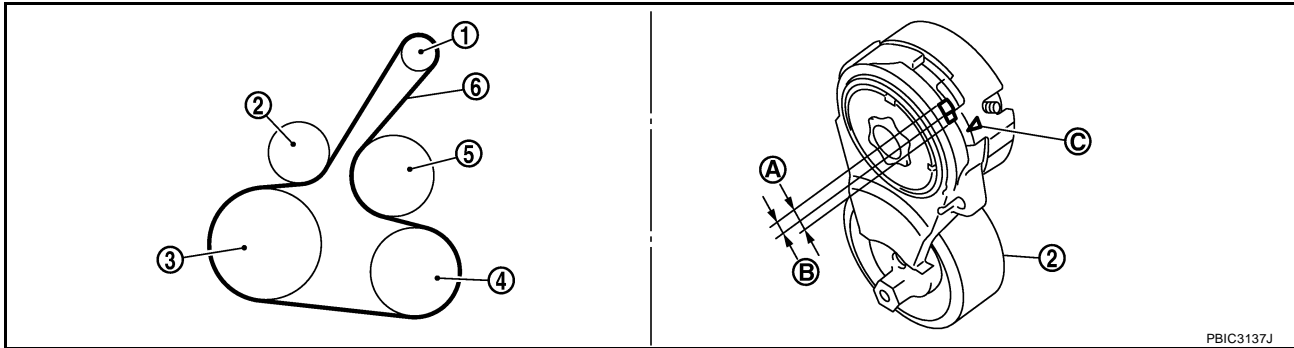

- | | | |
|--|---|----------------------|
| 1. Alternator | 2. Drive belt auto-tensioner | 3. Crankshaft pulley |
| 4. A/C compressor (models with A/C)
Idler pulley (models without A/C) | 5. Water pump | 6. Drive belt |
| A. Possible use range | B. Range when new drive belt is installed | C. Indicator |

Checking Drive Belts

ELS002CG

WARNING:

Be sure to perform this step when the engine is stopped.

- Make sure that the indicator (notch on fixed side) of drive belt auto-tensioner is within the possible use range (A).

NOTE:

- Check the drive belt auto-tensioner indication when the engine is cold.
- When new drive belt is installed, the indicator (notch on fixed side) should be within the range (B) in the figure.
- Visually check entire drive belt for wear, damage or cracks.
- If the indicator (notch on fixed side) is out of the possible use range or belt is damaged, replace drive belt.

Tension Adjustment

ELS002CH

Belt tension is not necessary, as it is automatically adjusted by drive belt auto-tensioner.

Changing Engine Coolant

ELS002CI

WARNING:

- To avoid being scalded, do not change engine coolant when engine is hot.
- Wrap a thick cloth around radiator cap and carefully remove the cap. First, turn the cap a quarter of a turn to release built-up pressure. Then turn the cap all the way.
- Be careful not to allow engine coolant to contact drive belt.

DRAINING ENGINE COOLANT

1. Open radiator drain plug (1) at the bottom of radiator, and then remove radiator cap.

- ⇐ Vehicle front

When draining all of engine coolant in the system, open water drain plug on cylinder block. Refer to [EM-75, "DISASSEMBLY"](#).

CAUTION:

- Perform this step when engine is cold.
- Do not spill engine coolant on drive belt.

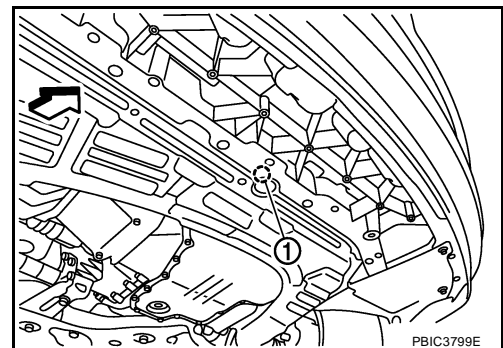

2. Remove reservoir tank as necessary, and drain engine coolant and clean reservoir tank before installing. Refer to [CO-13, "RADIATOR"](#).
3. Check drained engine coolant for contaminants such as rust, corrosion or discoloration.

ENGINE MAINTENANCE (MR20DE)

If contaminated, flush the engine cooling system. Refer to [CO-12, "FLUSHING COOLING SYSTEM"](#) .

REFILLING ENGINE COOLANT

1. Install the radiator drain plug. Install the reservoir tank and cylinder block drain plug, if removed for a total system drain or for engine removal or repair.

- **The radiator must be completely empty of coolant and water.**
- **Apply sealant to the threads of the cylinder block drain plugs. Use Genuine High Performance Thread Sealant or equivalent. Refer to [GI-44, "RECOMMENDED CHEMICAL PRODUCTS AND SEALANTS"](#) .**

Radiator drain plug : Refer to [CO-13, "Removal and Installation"](#) .

Cylinder block drain plug : Refer to [EM-181, "Removal and Installation"](#) .

2. If disconnected, reattach the upper radiator hose at the engine side.
3. Set the vehicle heater controls to the full HOT and heater ON position. Turn the vehicle ignition ON with the engine OFF as necessary to activate the heater mode.
4. Install the Tool by installing the radiator cap adapter onto the radiator neck opening. Then attach the gauge body assembly with the refill tube and the venturi assembly to the radiator cap adapter.

Tool number : KV991J0070 (J-45695)

5. Insert the refill hose into the coolant mixture container that is placed at floor level. Make sure the ball valve is in the closed position.

- **Use Genuine NISSAN Long Life Anti-freeze coolant or equivalent, mixed 50/50 with distilled water or demineralized water.**

Refer to [MA-16, "Anti-freeze Coolant Mixture Ratio"](#).

Engine coolant capacity (with reservoir tank) : Refer to [MA-14, "RECOMMENDED FLUIDS AND LUBRICANTS"](#) .

6. Install an air hose to the venturi assembly, the air pressure must be within specification.

Compressed air supply pressure : 5.7 - 8.5 kPa (5.6 - 8.4 kg/cm², 80 - 120 psi)

CAUTION:

The compressed air supply must be equipped with an air dryer.

7. The vacuum gauge will begin to rise and there will be an audible hissing noise. During this process open the ball valve on the refill hose slightly. Coolant will be visible rising in the refill hose. Once the refill hose is full of coolant, close the ball valve. This will purge any air trapped in the refill hose.

8. Continue to draw the vacuum until the gauge reaches 28 inches of vacuum. The gauge may not reach 28 inches in high altitude locations, refer to the vacuum specifications based on the altitude above sea level.

Altitude above sea level	Vacuum gauge reading
0 - 100 m (328 ft)	: 28 inches of vacuum
300 m (984 ft)	: 27 inches of vacuum
500 m (1,641 ft)	: 26 inches of vacuum
1,000 m (3,281 ft)	: 24 - 25 inches of vacuum

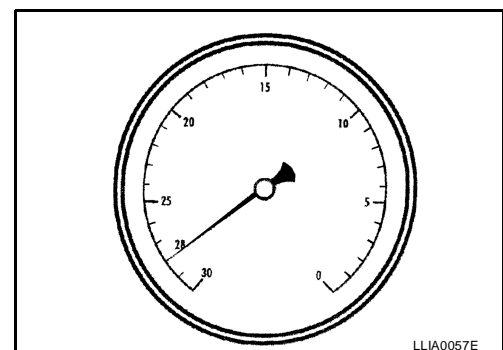
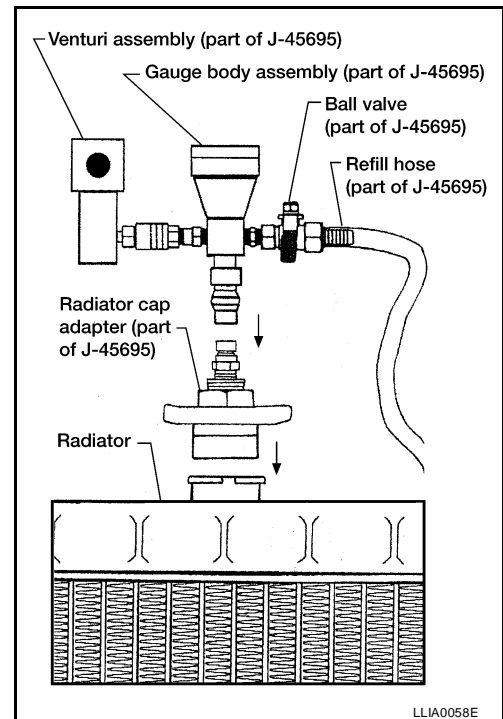

9. When the vacuum gauge has reached the specified amount, disconnect the air hose and wait 20 seconds to see if the system loses any vacuum. If the vacuum level drops, perform any necessary repairs to the system and repeat steps 6 - 8 to bring the vacuum to the specified amount. Recheck for any leaks.

ENGINE MAINTENANCE (MR20DE)

- Place the coolant container (with the refill hose inserted) at the same level as the top of the radiator. Then open the ball valve on the refill hose so the coolant will be drawn up to fill the cooling system. The cooling system is full when the vacuum gauge reads zero.

CAUTION:

Do not allow the coolant container to get too low when filling, to avoid air from being drawn into the cooling system.

- Remove the Tool from the radiator neck opening.
- Fill the cooling system reservoir tank to the specified level and install the radiator cap. Run the engine to warm up the cooling system and top up the system as necessary.

FLUSHING COOLING SYSTEM

- Install reservoir tank if removed. Refer to [CO-13, "RADIATOR"](#) .
- Install radiator drain plug.
 - If water drain plug on cylinder block is removed, close and tighten it. Refer to [EM-78, "ASSEMBLY"](#) .

CAUTION:

Be sure to clean radiator drain plug and install with new O-ring. Refer to [CO-13, "Components"](#) .

- Fill radiator and reservoir tank with water and reinstall radiator cap.
- Run engine and warm it up to normal operating temperature.
- Rev engine two or three times under no-load.
- Stop engine and wait until it cools down.
- Drain water from the cooling system. Refer to [CO-10, "DRAINING ENGINE COOLANT"](#) .
- Repeat steps 1 through 7 until clear water begins to drain from radiator.

Inspection LEVEL CHECK

ELS002CJ

- Check if the reservoir tank engine coolant level is within the "MIN" to "MAX" range when engine is cool.
- Adjust the engine coolant level as necessary.

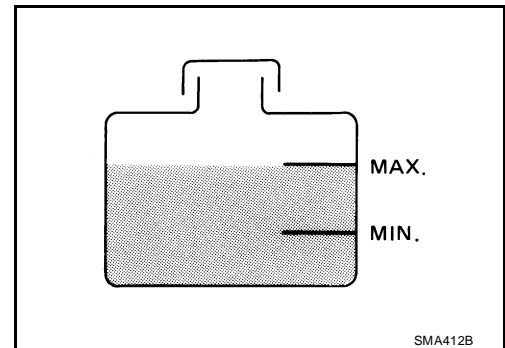

CHECKING COOLING SYSTEM FOR LEAKS

To check for leaks, apply pressure to the cooling system using Tool.

Tool number : EG17650301 (J-33984-A)

Testing pressure : 157 kPa (1.6 kg/cm² , 23 psi)

WARNING:

Never remove the radiator cap when the engine is hot. Serious burns could occur from high pressure coolant escaping from the radiator.

CAUTION:

Higher pressure than specified may cause radiator damage.

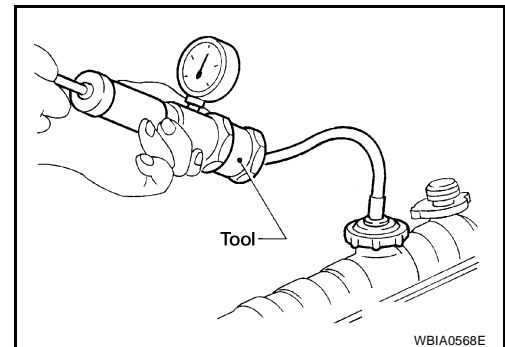

ENGINE MAINTENANCE (MR20DE)

Checking Fuel Lines

ELS002CK

Inspect fuel lines, fuel filler cap and fuel tank for improper attachment, leaks, cracks, damage, loose connections, chafing or deterioration.

If necessary, repair or replace damaged parts.

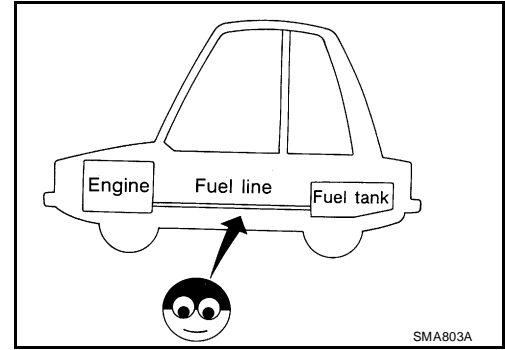

Changing Air Cleaner Filter REMOVAL

ELS002CL

1. Unclip the tabs (A) of both ends of the air cleaner cover (1).

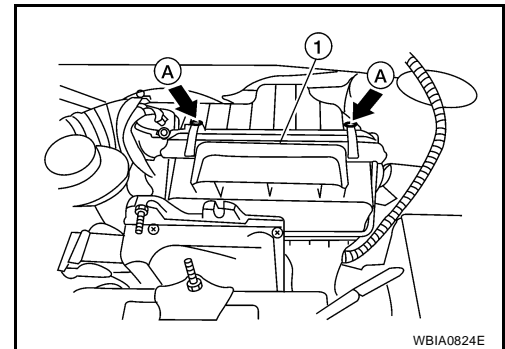

2. Remove the air cleaner filter and holder assembly from the air cleaner case.
3. Remove the air cleaner filter from the holder.

INSPECTION AFTER REMOVAL

It is necessary to replace it at the recommended intervals, more often under dusty driving conditions. Refer to [MA-8, "PERIODIC MAINTENANCE"](#) .

INSTALLATION

Installation is in the reverse order of removal.

Engine Oil Level INSPECTION

ELS002CY

NOTE:

Before starting engine, park vehicle on a level surface and check the engine oil level. If engine is already started, stop it and allow 10 minutes before checking.

1. Pull out oil level gauge and wipe it clean.
2. Insert oil level gauge and make sure the engine oil level is within the range (A) as shown.
3. If it is out of range, adjust it.

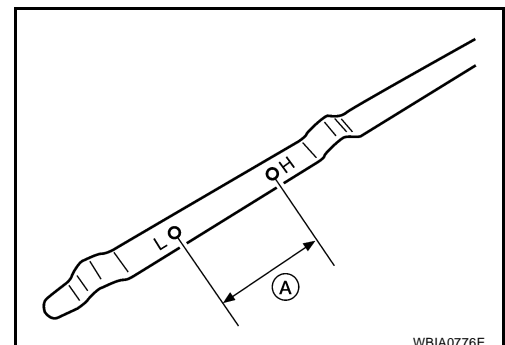

ENGINE OIL APPEARANCE

- Check engine oil for white turbidity or heavy contamination.

ENGINE MAINTENANCE (MR20DE)

- If engine oil becomes turbid and white, it is highly probable that it is contaminated with engine coolant. Repair or replace damaged parts.

ENGINE OIL LEAKAGE

Check for engine oil leakage around the following areas:

- Oil pan (upper and lower)
- Oil pan drain plug
- Oil pressure switch
- Oil filter
- Intake valve timing control solenoid valve
- Front cover
- Mating surface between cylinder block and cylinder head
- Mating surface between cylinder head and rocker cover
- Crankshaft oil seals (front and rear)
- Oil filter (for intake valve timing control)

OIL PRESSURE CHECK

WARNING:

- Be careful not to burn yourself, as engine oil may be hot.
- For engine oil pressure check the transaxle should be in “Park position” (CVT models) or “Neutral position” (M/T models), and apply the parking brake securely.

1. Disconnect harness connector at oil pressure switch (1), and remove oil pressure switch using a suitable tool.

- Oil pan (lower) (2)
- ← Front

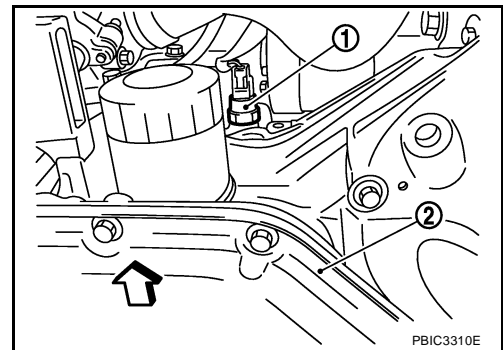

2. Install oil pressure gauge and hose.

Tool number : ST25051001 (J-25695-1)
: ST25052000 (J-25695-2)

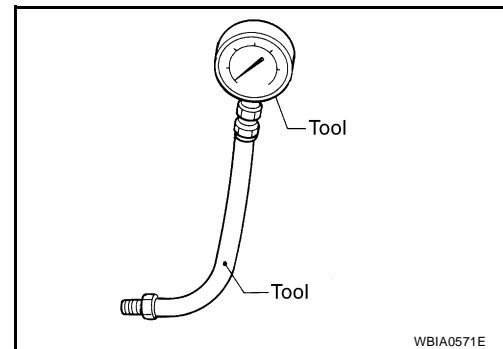

3. Check engine oil level. Refer to [MA-20, "Engine Oil Level"](#) .
4. Start engine and warm it up to normal operating temperature.
5. Check oil pressure with engine running under no-load.

NOTE:

When engine oil temperature is low, engine oil pressure becomes high.

ENGINE MAINTENANCE (MR20DE)

Engine oil pressure [Engine oil temperature at 80°C (176°F)]

Engine speed rpm	Approximate discharge pressure kPa (bar, kg/cm ² , psi)
Idle speed	More than 60 (0.60, 0.61, 9)
2,000	More than 200 (2.0, 2.0, 29)

If difference is extreme, check oil passage and oil pump for oil leaks.

6. After the inspections, install oil pressure switch as follows:
 - a. Remove old liquid gasket adhering to oil pressure switch and engine.
 - b. Apply liquid gasket and tighten oil pressure switch to specification.
Use Genuine Silicone RTV Sealant or equivalent. Refer to [GI-44, "Recommended Chemical Products and Sealants"](#).

Oil pressure switch : 14.7 N·m (1.5 kg·m, 11 ft·lb)

- c. Check engine oil level. Refer to [MA-20, "Engine Oil Level"](#).
- d. After warming up engine, make sure there are no engine leaks of oil with running engine.

Changing Engine Oil

ELS002CM

WARNING:

- **Be careful not to burn yourself, as engine oil may be hot.**
 - **Prolonged and repeated contact with used engine oil may cause skin cancer; try to avoid direct skin contact with used engine oil. If skin contact is made, wash thoroughly with soap or hand cleaner as soon as possible.**
1. Warm up engine, park vehicle on a level surface and check for engine oil leakage from engine components. Refer to [MA-21, "ENGINE OIL LEAKAGE"](#).

2. Stop engine and wait for 10 minutes.
3. Loosen oil filler cap (1) and then remove drain plug (2).

- Oil filter (3)
- ← Vehicle front

4. Drain engine oil.
5. Install drain plug (2) with new washer. Refer to [EM-26, "OIL PAN"](#).

CAUTION:

Be sure to clean drain plug (2) and install with new washer.

6. Refill with new engine oil. Refer to [MA-14, "RECOMMENDED FLUIDS AND LUBRICANTS"](#).

CAUTION:

- **The refill capacity depends on the engine oil temperature and drain time. Use these specifications for reference only.**
- **Always use oil level gauge to determine the proper amount of engine oil in the engine.**

7. Warm up engine and check area around drain plug (2) and oil filter (3) for engine oil leakage.
8. Stop engine and wait for 10 minutes.
9. Check the engine oil level. Refer to [MA-20, "Engine Oil Level"](#).

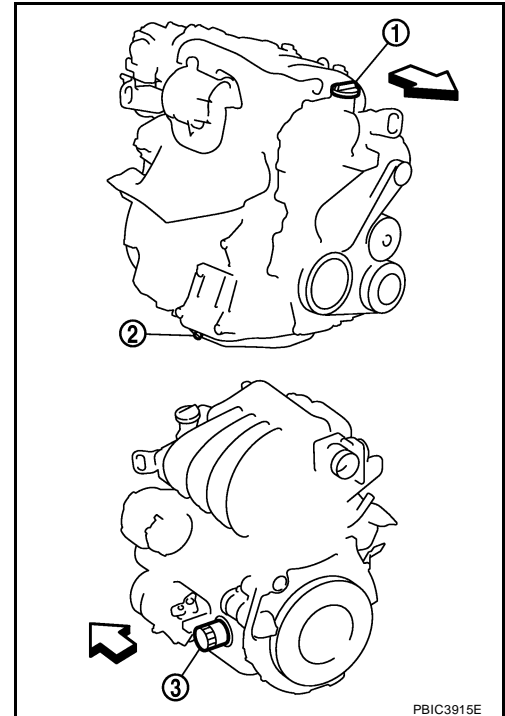

PBIC3915E

ENGINE MAINTENANCE (MR20DE)

ELS002CN

Engine Oil Filter REMOVAL

1. Remove oil filter using Tool (A).

Tool number : KV10115801 (J-38956)

- ← Front

CAUTION:

- Oil filter is provided with relief valve. Use Genuine NISSAN Oil Filter or equivalent.
- Be careful not to get burned when engine and engine oil may be hot.
- When removing, prepare a shop cloth to absorb any engine oil leakage or spillage.
- Do not allow engine oil to adhere to drive belt.
- Completely wipe off any engine oil that adheres to engine and vehicle.

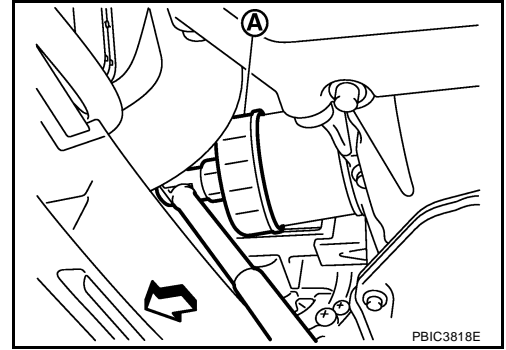

INSTALLATION

1. Remove foreign materials adhering to the oil filter installation surface.
2. Apply new engine oil to the oil seal contact surface of new oil filter.

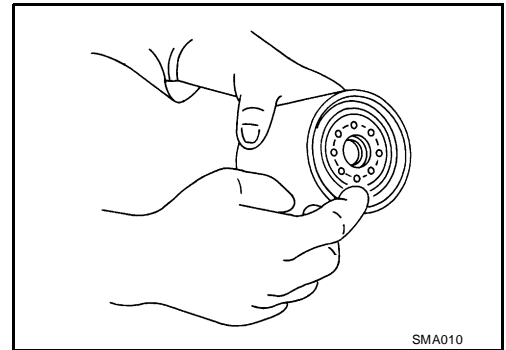

3. Screw oil filter manually until it touches the installation surface, then tighten it by 2/3 turn. Or tighten to specification.

Oil filter: : 17.7 N·m (1.8 kg·m, 13 ft·lb)

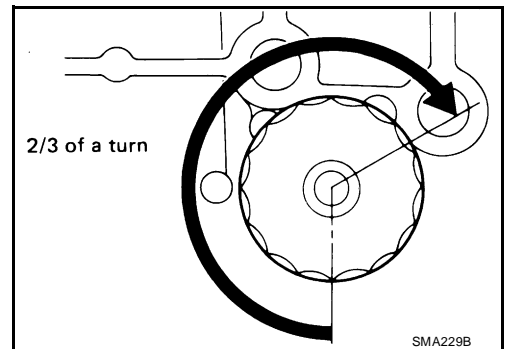

INSPECTION AFTER INSTALLATION

1. Check the engine oil level. Refer to [MA-20, "Engine Oil Level"](#) .
2. Start engine, and make sure there is no leaks of engine oil.
3. Stop engine and wait for 10 minutes.
4. Check the engine oil level and adjust engine oil. Refer to [MA-20, "Engine Oil Level"](#) .

Changing Spark Plugs

ELS002CO

1. Remove intake manifold. Refer to [EM-20, "INTAKE MANIFOLD"](#) .
2. Remove ignition coil. Refer to [EM-32, "Removal and Installation"](#)

CAUTION:

- Handle ignition coil carefully and avoid impacts.
- Never disassemble.

ENGINE MAINTENANCE (MR20DE)

- Remove spark plug using suitable tool.

CAUTION:
Never drop or shock it.

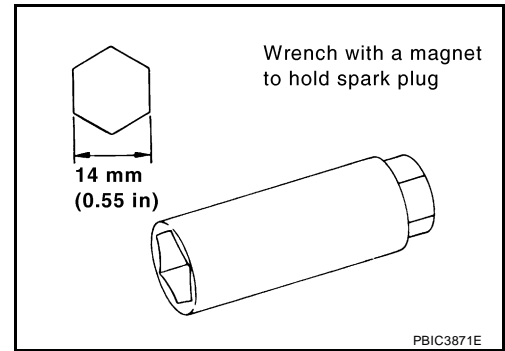

INSPECTION AFTER REMOVAL

CAUTION:

- Never drop or shock spark plug.
- Checking and adjusting spark plug gap is not required between change intervals.

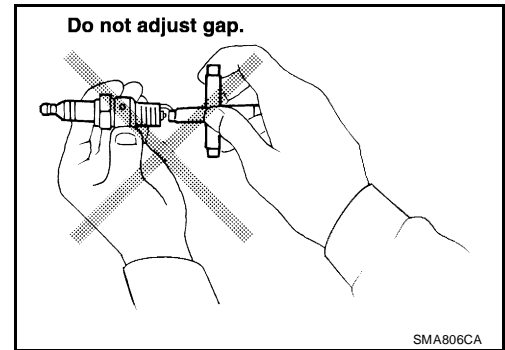

- If spark plug tip is covered with carbon, a spark plug cleaner may be used.

Cleaner air pressure : Less than 588 kPa (5.88 bar, 6 kg/cm² , 85 psi)

Cleaning time : Less than 20 seconds

- Never use wire brush for cleaning spark plug.

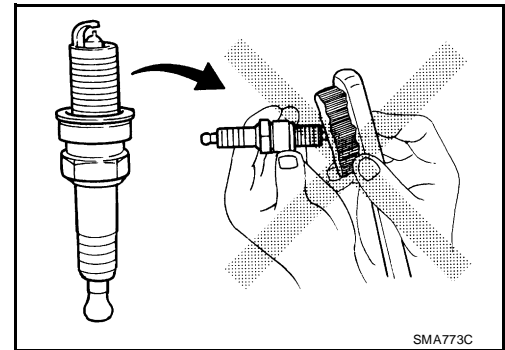

INSTALLATION

- Install rocker cover gasket to rocker cover.
- Install rocker cover.
 - Tighten bolts in two steps separately in numerical order as shown.

1st step : 1.96 N·m (0.20 kg·m, 17 in·lb)

2nd step : 8.33 N·m (0.85 kg·m, 73 in·lb)

- ↔ Engine front

CAUTION:
Check if rocker cover gasket is not dropped from the installation groove of rocker cover.

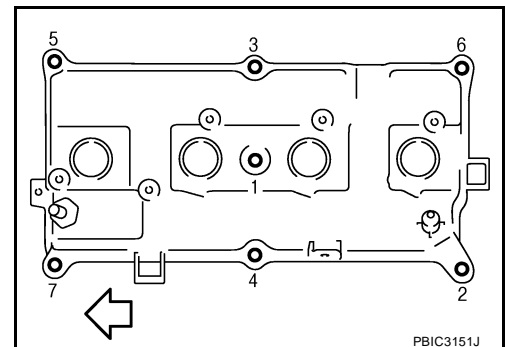

ENGINE MAINTENANCE (MR20DE)

3. Install spark plug using suitable tool.

Plug type : Platinum tipped
Make : NGK
Part number : PLZKAR6A-11
Gap (nominal) : 1.1 mm (0.043 in)

CAUTION:
Never drop or shock it.

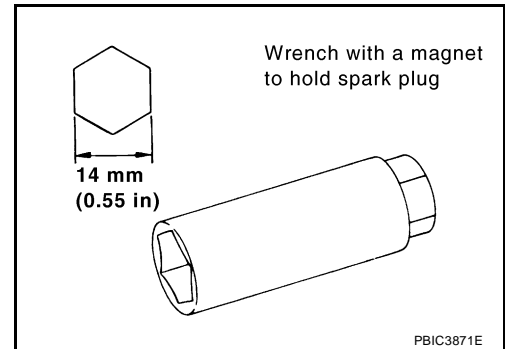

4. Install ignition coil.

CAUTION:
● Handle it carefully and avoid impacts.
● Never disassemble.

5. Install intake manifold. Refer to [EM-20, "INTAKE MANIFOLD"](#) .

Checking EVAP Vapor Lines

ELS002CP

1. Visually inspect EVAP vapor lines for improper attachment and for cracks, damage, loose connections, chafing and deterioration.
2. Inspect fuel tank filler cap vacuum relief valve for clogging, sticking, etc.
Refer to [EC-35, "EVAPORATIVE EMISSION SYSTEM"](#) .

A
B
C
D
E
F
G
H
I
J
K
MA
M

ENGINE MAINTENANCE (QR25DE ENGINE)

PF1:10001

Checking Drive Belts

ELS002CQ

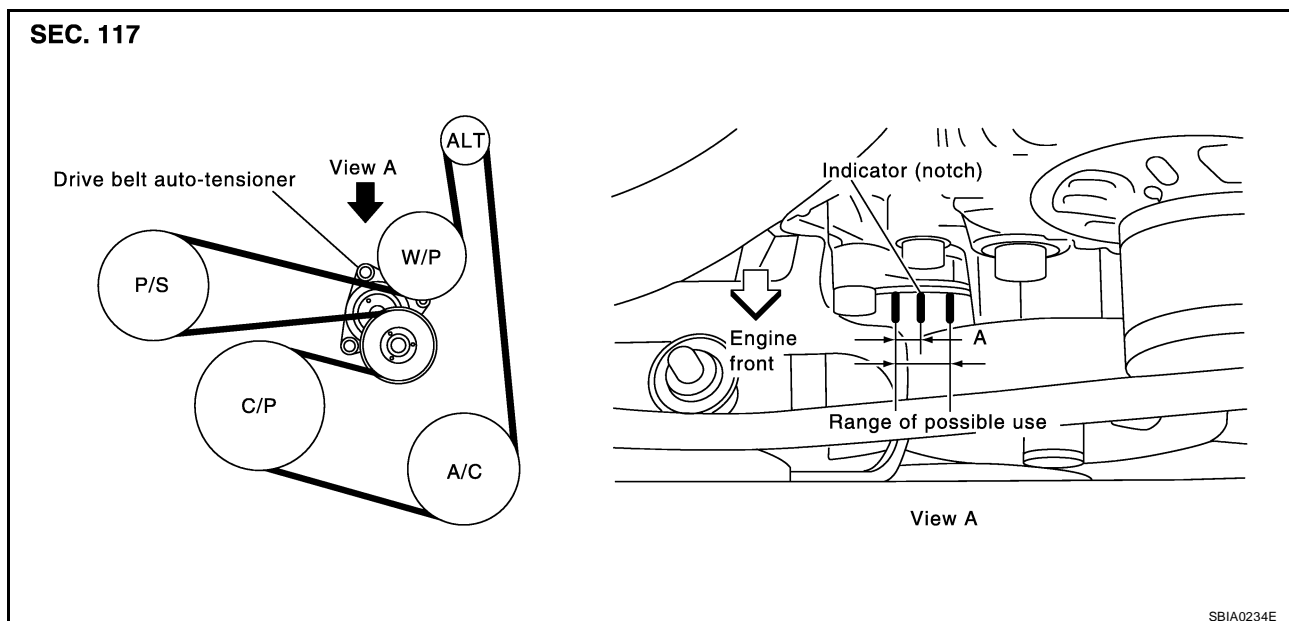

SBIA0234E

WARNING:

Inspect the drive belt only when the engine is stopped.

NOTE:

On vehicles not equipped with A/C, there is an idler pulley in the position for the drive belt routing.

- Make sure that the stamp mark of drive belt auto-tensioner is within the usable range.

NOTE:

- Check the drive belt auto-tensioner indicator (notch) when the engine is cold.
- When the new drive belt is installed, the range should be "A" as shown.
- Visually check entire belt for wear, damage or cracks.
- If the indicator is out of allowable use range or belt is damaged, replace the belt.

Tension Adjustment

ELS002CR

- Belt tension is not manually adjustable, it is automatically adjusted by the drive belt auto-tensioner.

Changing Engine Coolant

ELS002CS

WARNING:

- To avoid being scalded, never change the coolant when the engine is hot.
- Wrap a thick cloth around cap and carefully remove the cap. First, turn the cap a quarter of a turn to release built-up pressure. Then push down and turn the cap all the way to remove.

DRAINING ENGINE COOLANT

1. Remove the engine undercover using power tool.
2. Open the radiator drain plug at the bottom of the radiator, and remove the radiator filler cap. This is the only step required when partially draining the cooling system (radiator only).
 - Do not to allow the coolant to contact the drive belts.
3. Follow this step for heater core removal/replacement only. Disconnect the upper heater hose at the engine side and apply moderate air pressure [103.46 kPa (15 psi, 1.055 kg/cm²) maximum air pressure] into the hose for 30 seconds to blow the excess coolant out of the heater core.
4. When draining all of the coolant in the system, remove the reservoir tank and drain the coolant, then clean the reservoir tank before installation.

ENGINE MAINTENANCE (QR25DE ENGINE)

- When draining all of the coolant in the system for engine removal or repair, open the drain plug on the cylinder block.

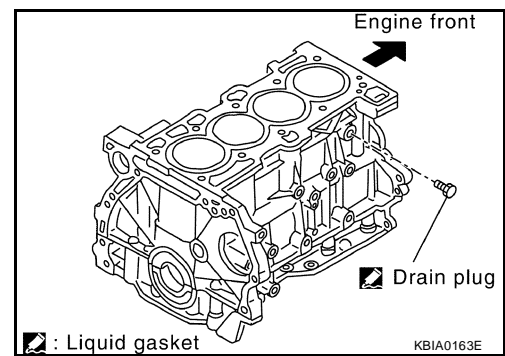

- Check the drained coolant for contaminants such as rust, corrosion or discoloration. If the coolant is contaminated, flush the engine cooling system. Refer to [CO-36, "FLUSHING COOLING SYSTEM"](#).

REFILLING ENGINE COOLANT

- Install the radiator drain plug. Install the reservoir tank and cylinder block drain plug, if removed for a total system drain or for engine removal or repair.
 - The radiator must be completely empty of coolant and water.
 - Apply sealant to the threads of the cylinder block drain plugs. Use Genuine High Performance Thread Sealant or equivalent. Refer to [GI-44, "RECOMMENDED CHEMICAL PRODUCTS AND SEALANTS"](#).

Radiator drain plug : Refer to [CO-37, "Removal and Installation"](#).

Cylinder block drain plug : Refer to [MA-26, "DRAINING ENGINE COOLANT"](#).

- If disconnected, reattach the upper radiator hose at the engine side.
- Set the vehicle heater controls to the full HOT and heater ON position. Turn the vehicle ignition ON with the engine OFF as necessary to activate the heater mode.
- Install the Tool by installing the radiator cap adapter onto the radiator neck opening. Then attach the gauge body assembly with the refill tube and the venturi assembly to the radiator cap adapter.

Tool number : KV991J0070 (J-45695)

- Insert the refill hose into the coolant mixture container that is placed at floor level. Make sure the ball valve is in the closed position.

- Use Genuine NISSAN Long Life Anti-freeze coolant or equivalent, mixed 50/50 with distilled water or demineralized water. Refer to [MA-16, "Anti-freeze Coolant Mixture Ratio"](#).

Engine coolant capacity (with reservoir tank) : Refer to [MA-14, "RECOMMENDED FLUIDS AND LUBRICANTS"](#).

- Install an air hose to the venturi assembly, the air pressure must be within specification.

Compressed air supply pressure : 5.7 - 8.5 kPa (5.6 - 8.4 kg/cm²), 80 - 120 psi

CAUTION:

The compressed air supply must be equipped with an air dryer.

- The vacuum gauge will begin to rise and there will be an audible hissing noise. During this process open the ball valve on the refill hose slightly. Coolant will be visible rising in the refill hose. Once the refill hose is full of coolant, close the ball valve. This will purge any air trapped in the refill hose.

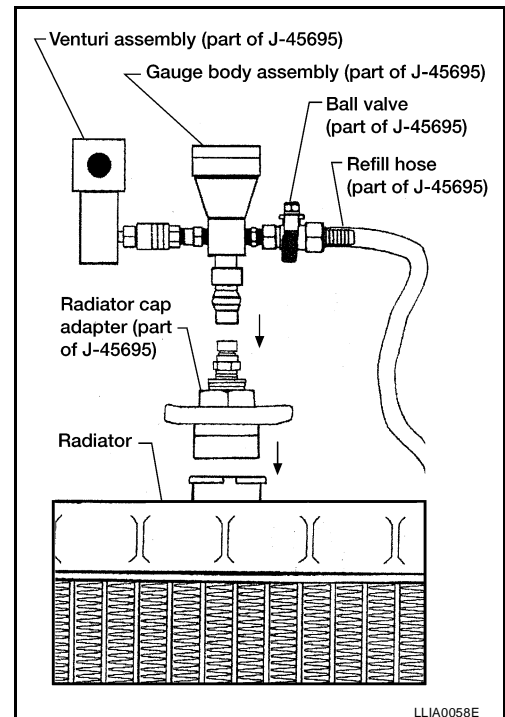

ENGINE MAINTENANCE (QR25DE ENGINE)

8. Continue to draw the vacuum until the gauge reaches 28 inches of vacuum. The gauge may not reach 28 inches in high altitude locations, refer to the vacuum specifications based on the altitude above sea level.

Altitude above sea level	Vacuum gauge reading
0 - 100 m (328 ft)	: 28 inches of vacuum
300 m (984 ft)	: 27 inches of vacuum
500 m (1,641 ft)	: 26 inches of vacuum
1,000 m (3,281 ft)	: 24 - 25 inches of vacuum

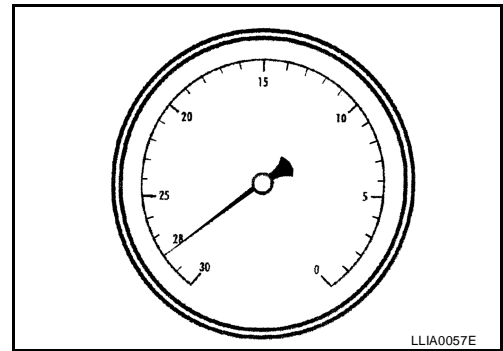

9. When the vacuum gauge has reached the specified amount, disconnect the air hose and wait 20 seconds to see if the system loses any vacuum. If the vacuum level drops, perform any necessary repairs to the system and repeat steps 6 - 8 to bring the vacuum to the specified amount. Recheck for any leaks.
10. Place the coolant container (with the refill hose inserted) at the same level as the top of the radiator. Then open the ball valve on the refill hose so the coolant will be drawn up to fill the cooling system. The cooling system is full when the vacuum gauge reads zero.

CAUTION:

Do not allow the coolant container to get too low when filling, to avoid air from being drawn into the cooling system.

11. Remove the Tool from the radiator neck opening.
12. Fill the cooling system reservoir tank to the specified level and install the radiator cap. Run the engine to warm up the cooling system and top up the system as necessary.

FLUSHING COOLING SYSTEM

1. Fill the radiator from the filler cap above the radiator upper hose and reservoir tank, with water and reinstall the filler cap above the radiator upper hose.
2. Run the engine until it reaches normal operating temperature.
3. Press the engine accelerator two or three times under no-load.
4. Stop the engine and wait until it cools down.
5. Drain the water.
6. Repeat steps 1 through 5 until clear water begins to drain from the radiator.

Checking Fuel Lines

Inspect the fuel lines and fuel tank for improperly attached hoses, leaks, cracks, damage, loose connections, chafing, or deterioration. If necessary, repair or replace any damaged parts.

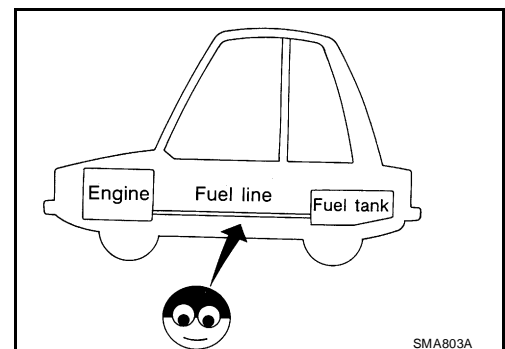

Changing Air Cleaner Filter

ELS002CA

ENGINE MAINTENANCE (QR25DE ENGINE)

CHANGING THE AIR CLEANER ELEMENT

1. Depress the air cleaner case lid side clips and remove.
2. Remove the air cleaner element.
3. Install a new air cleaner element.
4. Installation is in the reverse order of removal.

Engine Oil OIL LEVEL

ELS002CZ

- Before starting the engine, check the oil level. If the engine is already started, stop it and allow 10 minutes before checking.
- Check that the oil level is within the range on the dipstick.
- If it is out of range, add oil as necessary. Refer to [GI-44, "RECOMMENDED CHEMICAL PRODUCTS AND SEALANTS"](#).

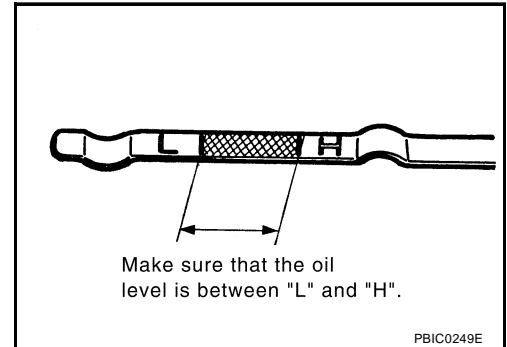

ENGINE OIL APPEARANCE

- Check engine oil for white milky or excessive contamination.
- If engine oil becomes milky, it is highly probable that it is contaminated with engine coolant. Repair or replace damaged parts.

OIL LEAKAGE

Check for oil leakage around the following areas:

- Oil pan
- Oil pan drain plug
- Oil pressure sensor
- Oil filter
- IVTC cover
- Front cover
- Mating surface between cylinder block and cylinder head
- Mating surface between cylinder head and rocker cover
- Crankshaft oil seal

Changing Engine Oil

ELS002D0

WARNING:

- **Be careful not to burn yourself, as the engine oil may be hot.**
 - **Prolonged and repeated contact with used engine oil may cause skin cancer: try to avoid direct skin contact with used oil. If skin contact is made, wash thoroughly with soap or hand cleaner as soon as possible.**
1. Position the vehicle so it is level on the hoist.
 2. Warm up the engine, and check for oil leaks from the engine.
 3. Stop engine and wait for 10 minutes.
 4. Remove the oil pan drain plug and oil filler cap.
 5. Drain the engine oil.
 6. Install the oil pan drain plug with a new washer and refill the engine with new engine oil.

Oil specification and capacity : Refer to [GI-44, "RECOMMENDED CHEMICAL PRODUCTS AND SEALANTS"](#).

Oil pan drain plug : 34.3 N-m (3.5 kg-m, 25 ft-lb)

ENGINE MAINTENANCE (QR25DE ENGINE)

Oil Capacity (Approximate)

Drain and refill	With oil filter change	4.3 ℓ (4 1/2 US qt, 3 3/4 Imp qt)
	Without oil filter change	4.0 ℓ (4 1/4 US qt, 3 1/2 Imp qt)
Dry engine (engine overhaul)		4.6 ℓ (4 7/8 US qt, 4 Imp qt)

CAUTION:

- Be sure to clean the drain plug and install using a new washer.
- The refill capacity depends on the oil temperature and drain time. Use these specifications for reference only.
- Always use the dipstick to determine when the proper amount of oil is in the engine.

7. Warm up the engine and check the area around the drain plug and oil filter for oil leakage.
8. Stop the engine and wait for 10 minutes.
9. Check the oil level using the dipstick.

CAUTION:

Do not overfill the engine oil.

Changing Oil Filter REMOVAL

ELS002D1

1. Remove the oil filter using Tool.

Tool number : KV10115801 (J-38956)

CAUTION:

- Be careful not to get burned when the engine and engine oil are hot.
- When removing, prepare a shop cloth to absorb any oil leakage or spillage.
- Do not allow engine oil to adhere to the drive belts.
- Completely wipe off any oil that adheres to the engine and the vehicle.
- The oil filter has a built in pressure relief valve. Use a genuine NISSAN oil filter or equivalent

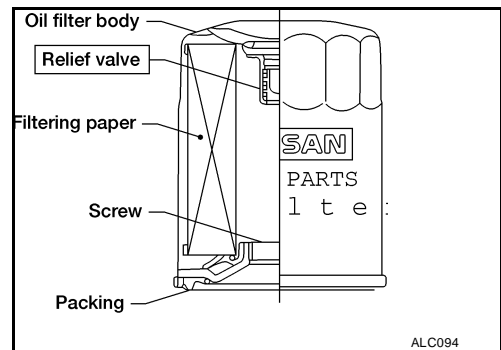
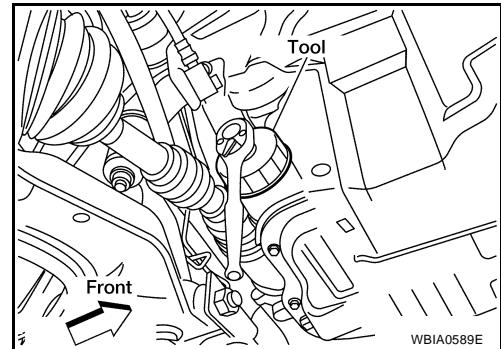

INSTALLATION

1. Clean off any foreign materials adhering to the oil filter installation surface.
2. Apply engine oil to the oil seal surface of the new oil filter.

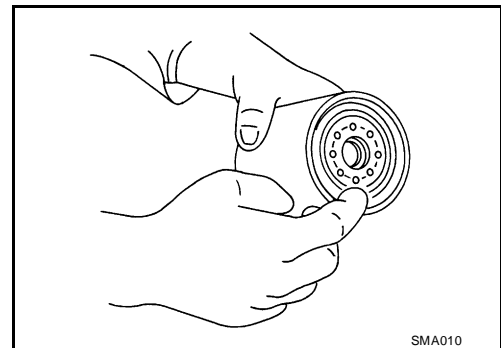

ENGINE MAINTENANCE (QR25DE ENGINE)

3. Screw the new oil filter manually until it touches the installation surface, then tighten it by 2/3 turn. Or tighten to specification below.

Oil filter : 17.6 N-m (1.8 kg-m, 13 ft-lb)

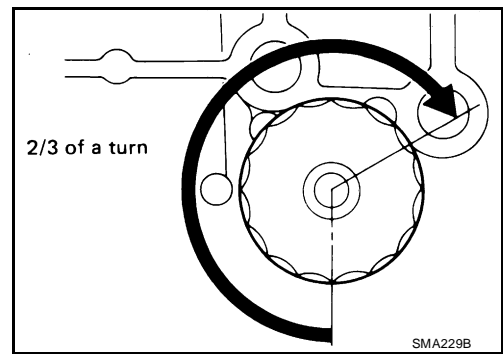

4. Check oil level and add engine oil as necessary. Refer to [LU-15, "ENGINE OIL"](#) .
5. After warming up the engine, check for oil leaks.

Changing Spark Plugs

ELS002CV

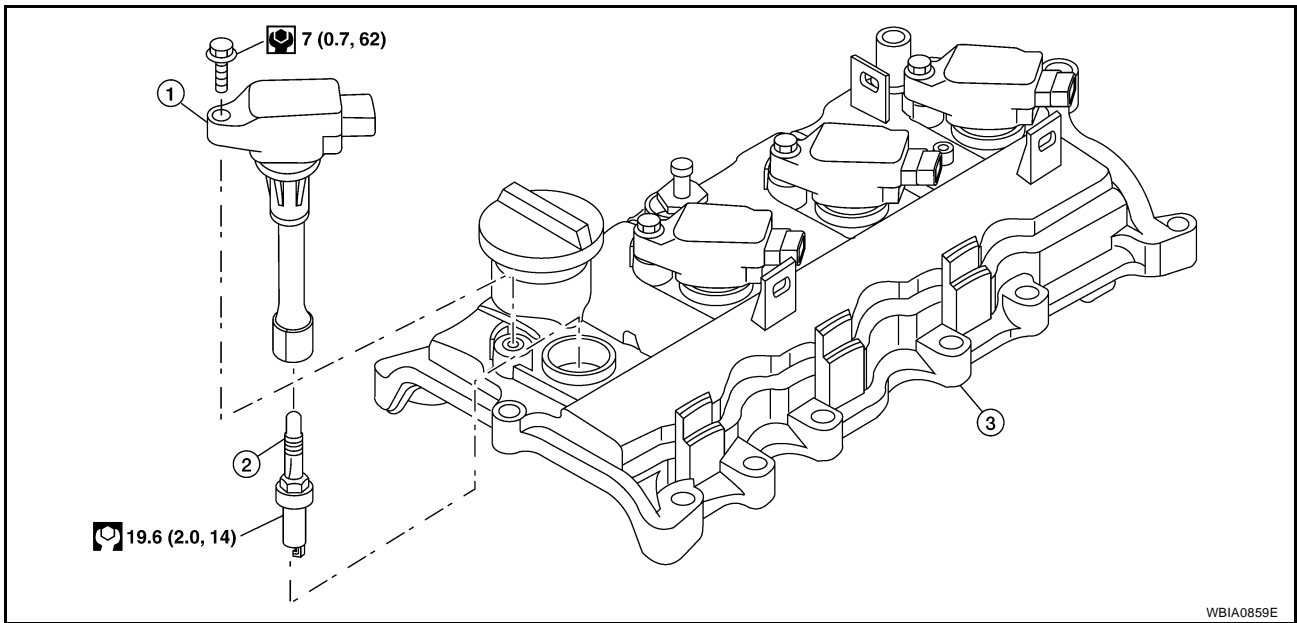

1. Ignition coil

2. Spark plug

3. Rocker cover

REMOVAL

1. Remove the ignition coil. Refer to [EM-141, "Removal and Installation"](#) .
2. Remove the spark plug with a suitable spark plug wrench.

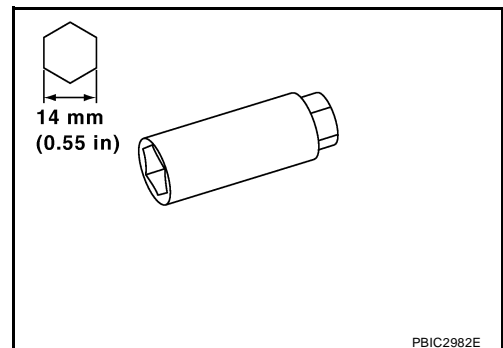

A
B
C
D
E
F
G
H
I
J
K
MA
M

ENGINE MAINTENANCE (QR25DE ENGINE)

INSPECTION AFTER REMOVAL

- Do not use a wire brush for cleaning the spark plugs. Replace as necessary.

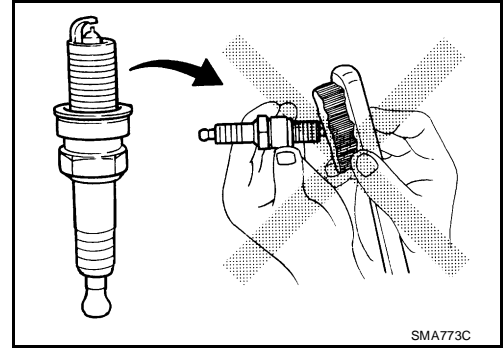

- If plug is covered with carbon, a spark plug cleaner may be used.

Cleaner air pressure : less than 588 kPa (6 kg/cm² , 85 psi)

Cleaning time : less than 20 seconds

- Checking and adjusting plug gap is not required between change intervals. If the gap is out of specification, replace the spark plug.

Gap (nominal) : 1.1 mm (0.043 in)

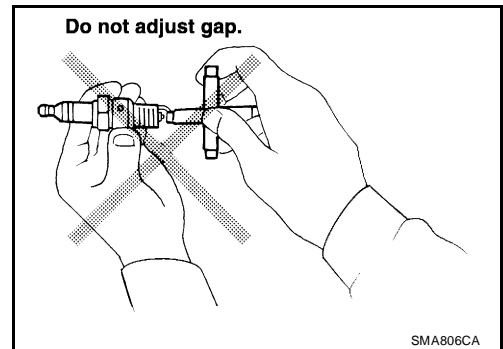

INSTALLATION

Installation is in the reverse order of removal.

Spark Plug Types

Temperature range	NGK
Standard type	DILKAR6A-11
Gap (nominal)	1.1 mm (0.043 in)

Checking EVAP Vapor Lines

ELS002CE

- Visually inspect EVAP vapor lines for improper attachment and for cracks, damage, loose connections, chafing and deterioration.
- Inspect fuel tank filler cap vacuum relief valve for clogging and sticking.

Changing In-cabin Microfilter

ELS002AN

SEC. 270

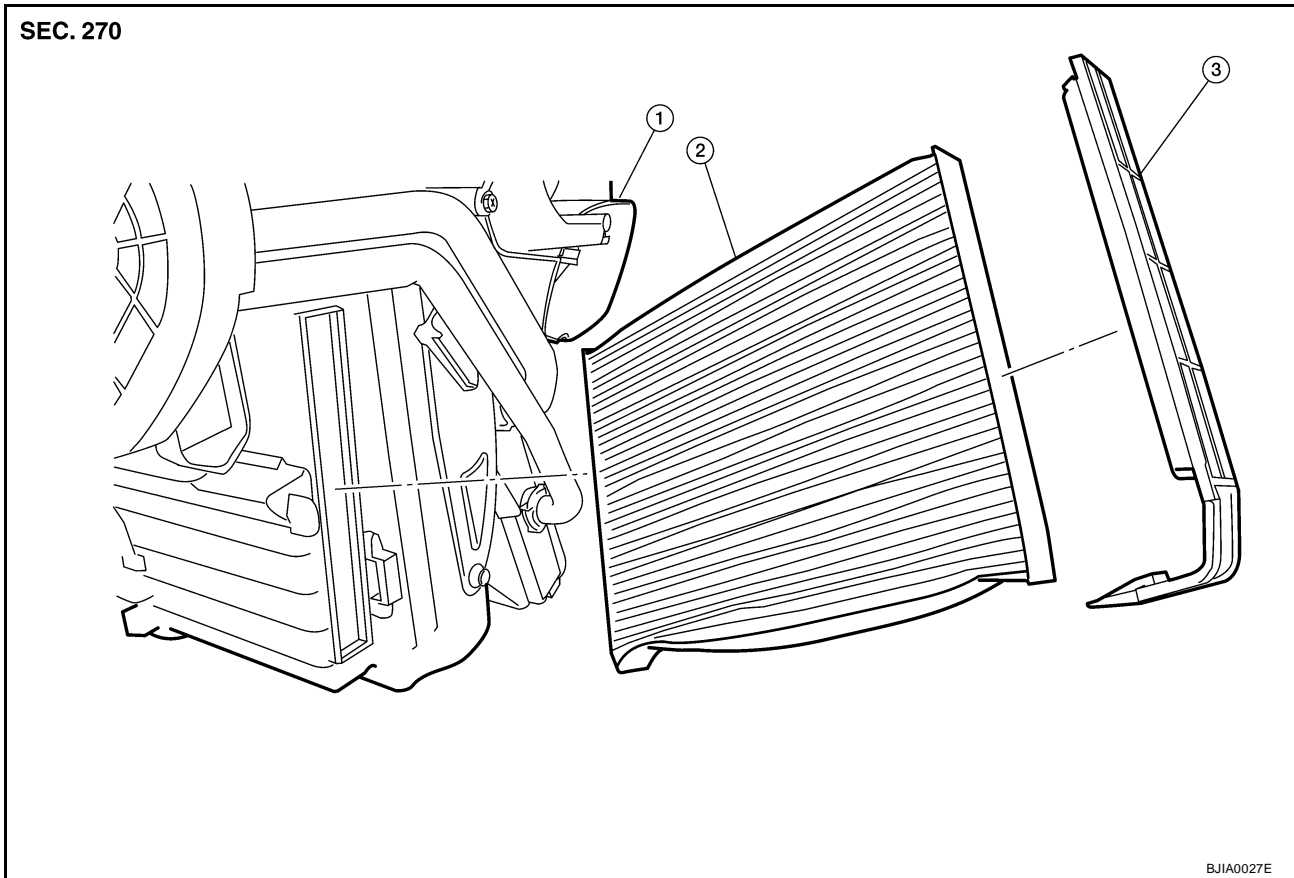

1. Heater and cooling unit assembly 2. In-cabin microfilter 3. Filter cover

1. Remove the filter cover.
 - a. Release the filter cover tab (A) the pull the bottom of the filter cover out tilting it at an angle
 - b. Pull down the filter cover to disengage the hook at the top and remove the filter cover.

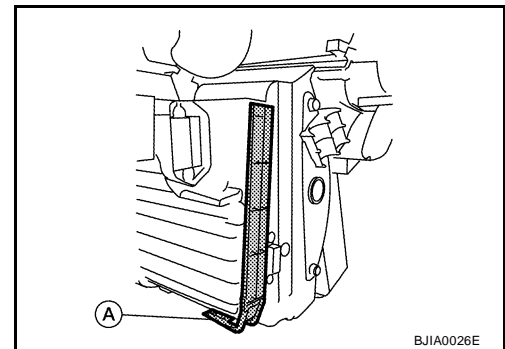

2. Remove the in-cabin microfilter.
3. Install the new in-cabin microfilter.

CAUTION:

- Insert the new filter with the “UP” arrow in the correct orientation.
- Insert the new filter with the “UP” arrow side of the filter facing the front of the vehicle.

4. Install the filter cover.
 - a. Insert the hook at the top of the filter cover into the heater and cooling unit case.

A
B
C
D
E
F
G
H
I
J
K
MA
M

CHASSIS AND BODY MAINTENANCE

- b. Swing the filter cover into the heater and cooling unit case until the filter cover tab (A) snaps securely on the heater and cooling unit case.

CAUTION:

Check the filter cover to make sure it is securely fastened to the heater and cooling unit case.

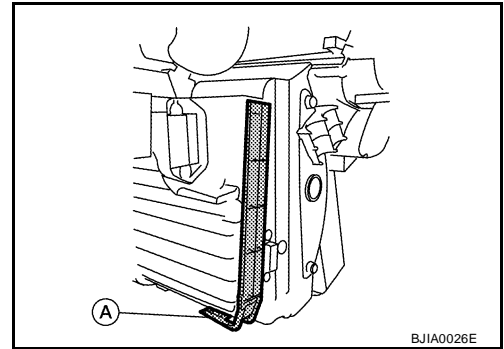

Checking Exhaust System

ELS002A0

Check the exhaust pipes, muffler, and exhaust mounts for improper attachment, leaks, cracks, damage, chafing, or deterioration.

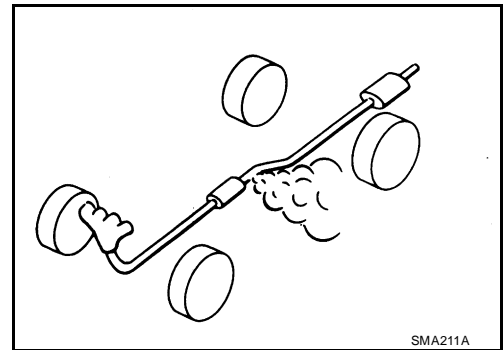

Checking CVT Fluid FLUID LEVEL CHECK

ELS002AP

Fluid level should be checked with the fluid warmed up to 50 to 80°C (122 to 176°F).

1. Check for fluid leakage.
2. With the engine warmed up, drive the vehicle to warm up the CVT fluid. When ambient temperature is 20°C (68°F), it takes about 10 minutes for the CVT fluid to warm up to 50 to 80°C (122 to 176°F).
3. Park the vehicle on a level surface and set the parking brake.
4. With engine at idle, while depressing brake pedal, move the selector lever throughout the entire shift range and return it to the "P" position.

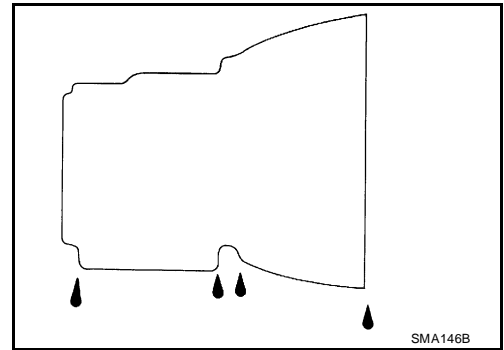

5. Press the tab on the CVT fluid level gauge to release the lock and pull out the CVT fluid level gauge from the CVT fluid charging pipe.

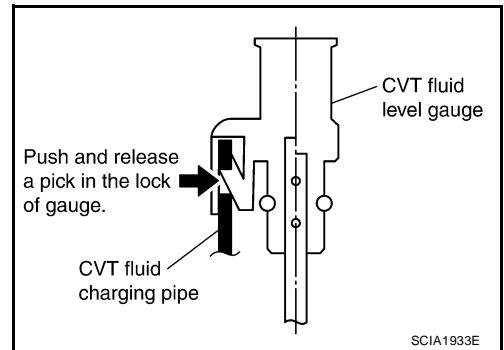

CHASSIS AND BODY MAINTENANCE

- Wipe fluid off the CVT fluid level gauge. Then rotate the CVT fluid level gauge 180° and re-insert it into the CVT charging pipe as far as it will go.

CAUTION:

Always use lint free paper towels to wipe fluid off the CVT fluid level gauge.

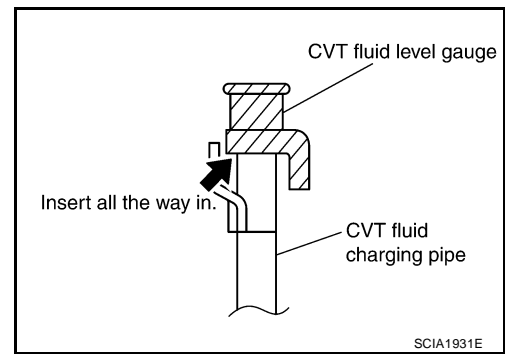

- Remove the CVT fluid level gauge and check that the fluid level is within the specified range as shown. If the fluid level is at or below the low side of the range, add the necessary specified NISSAN CVT fluid through the CVT charging pipe.

Fluid grade: Refer to [MA-14, "MR20DE"](#) .

CAUTION:

- Only use specified NISSAN CVT fluid.
- Do not overfill the CVT.

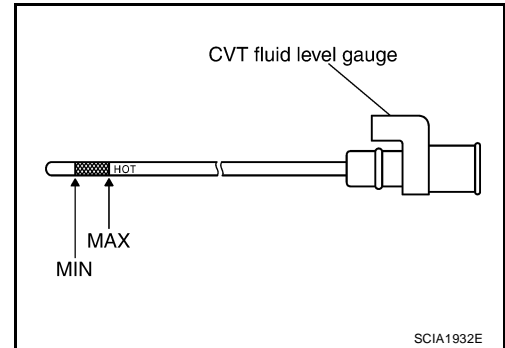

- Install the CVT fluid level gauge to the CVT fluid charging pipe until it locks.

CAUTION:

When CVT fluid level gauge is installed into the CVT fluid charging pipe, make sure that the CVT fluid level gauge is securely locked in place.

FLUID CONDITION CHECK

Fluid status	Conceivable cause	Required operation
Varnished (viscous varnish state)	Clutch, brake scorched	Replace the CVT fluid and check the CVT main unit and the vehicle for malfunctions (wire harness, cooler pipes, etc.)
Milky white or cloudy	Water in the fluid	Replace the CVT fluid and check for places where water is getting in.
Large amount of metal powder mixed in fluid	Unusual wear of sliding parts within CVT	Replace the CVT fluid and check for improper operation of the CVT.

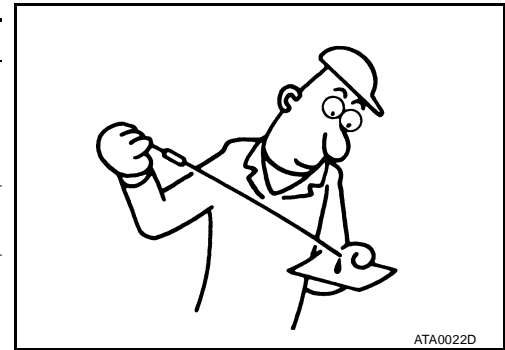

Changing CVT Fluid

- Remove drain plug, and drain CVT fluid from oil pan.
- Install drain plug with new gasket to oil pan and tighten to the specified torque.

Drain plug: Refer to [CVT-204, "COMPONENTS"](#) .

CAUTION:

Do not reuse drain plug gasket.

- Fill CVT fluid from CVT fluid charging pipe to the specified level.

Fluid grade and capacity: Refer to [MA-14, "MR20DE"](#) .

CAUTION:

- Use only Genuine NISSAN CVT Fluid NS-2. Do not mix with other fluid.
- Using CVT fluid other than Genuine NISSAN CVT Fluid NS-2 will deteriorate in driveability and CVT durability, and may damage the CVT, which is not covered by the warranty.
- When filling CVT fluid, take care not to scatter fluid on heat generating parts such as exhaust.
- Sufficiently shake the container of CVT fluid before using.

CHASSIS AND BODY MAINTENANCE

4. With the engine warmed up, drive the vehicle in an urban area. When ambient temperature is 20°C (68°F), it takes about 10 minutes for the CVT fluid to warm up to 50 to 80°C (122 to 176°F).
5. Check CVT fluid level and condition. Refer to [CVT-15, "Checking CVT Fluid"](#) .
6. Repeat steps 1 through 5 if CVT fluid is contaminated.

CAUTION:

Delete CVT fluid deterioration date with CONSULT-III after changing CVT fluid.

Checking Clutch Fluid Level and Leaks

ELS002D3

If fluid level is extremely low, check clutch system for leaks.

Checking Clutch System

ELS002D4

Check fluid lines and operating cylinder for improper attachment, cracks, damage, loose connections, chafing and deterioration.

Changing M/T Oil - RS6F94R DRAINING

ELS002D5

1. Start engine and let it run to warm up transaxle.
2. Stop engine. Remove drain plug (1) and drain oil.
3. Install a new gasket onto drain plug (1) and install it into transaxle. Tighten drain plug to specification. Refer to [MT-19, "Case and Housing Components"](#) .

CAUTION:

Do not reuse gasket.

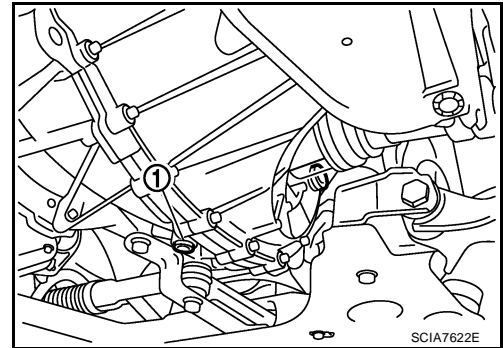

FILLING

1. Remove filler plug (1). Fill with new oil until oil level reaches the specified limit at filler plug hole as shown.

Oil grade and capacity

: Refer to [MA-14, "MR20DE"](#) .

2. After refilling oil, check oil level. Install a new gasket on filler plug (1), then install it into transaxle. Tighten filler plug to specification. Refer to [MT-19, "Case and Housing Components"](#) .

CAUTION:

Do not reuse gasket.

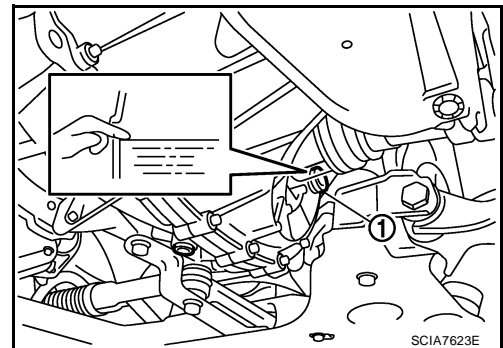

Checking M/T Oil - RS6F94R OIL LEAKAGE AND OIL LEVEL

ELS002D6

1. Make sure that oil is not leaking from transaxle or around it.
2. Remove filler plug (1) and check oil level at filler plug hole as shown.

CAUTION:

Do not start engine while checking oil level.

3. Install a new gasket onto filler plug (1) and install it into transaxle. Tighten filler plug to specification. Refer to [MT-19, "Case and Housing Components"](#) .

CAUTION:

Do not reuse gasket.

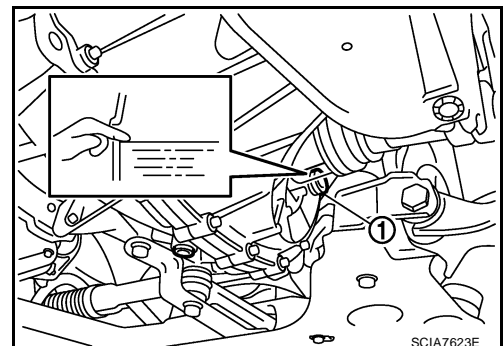

Changing M/T Oil - RS6F52A and RS6F52H

ELS002D7

DRAINING

1. Start engine and let it run to warm up transaxle.
2. Stop engine. Remove drain plug and drain oil.
3. Set a gasket on drain plug and install it to transaxle. Tighten drain plug to the specified torque. Refer to [MT-68, "Case and Housing Components"](#) .

CAUTION:

Never reuse gasket.

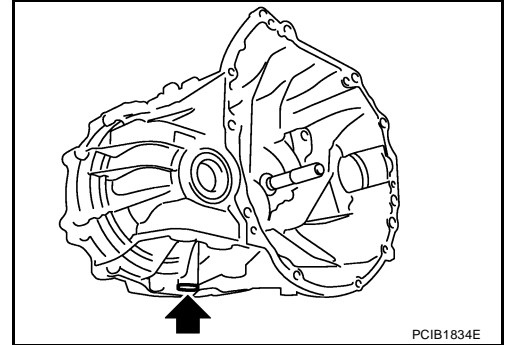

FILLING

1. Remove plug (with ABS models) (1) or speedometer pinion gear (without ABS models) (1). Fill with new oil to transaxle.

A : Suitable gauge

Oil grade and viscosity : Refer to [MA-14, "MR20DE"](#) .

Oil capacity (reference) : Refer to [MT-123, "General Specifications"](#) .

2. After refilling oil, check oil level.
3. Set a O-ring on plug (with ABS models) (1) or speedometer pinion gear (without ABS models) (1) and then install it to transaxle. Tighten mounting bolt to the specified torque. Refer to [MT-68, "Case and Housing Components"](#) .

CAUTION:

Never reuse O-ring.

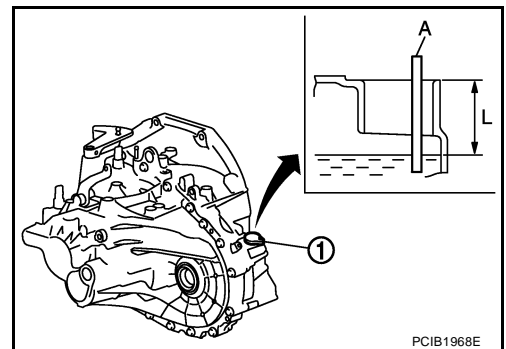

Checking M/T Oil - RS6F52A and RS6F52H

ELS002D8

OIL LEAKAGE AND OIL LEVEL

1. Make sure that oil is not leaking from transaxle or around it.
2. Remove plug (with ABS models) (1) or speedometer pinion gear (without ABS models) (1).
3. Measure oil level using a suitable gauge (A) as shown in the figure, and then check if it is within the specifications.

Oil level "L" : Refer to [MT-123, "General Specifications"](#) .

CAUTION:

Never start engine while checking oil level.

4. Set a O-ring on plug (with ABS models) (1) or speedometer pinion gear (without ABS models) (1) and then install it to transaxle. Tighten mounting bolt to the specified torque. Refer to [MT-68, "Case and Housing Components"](#) .

CAUTION:

Never reuse O-ring.

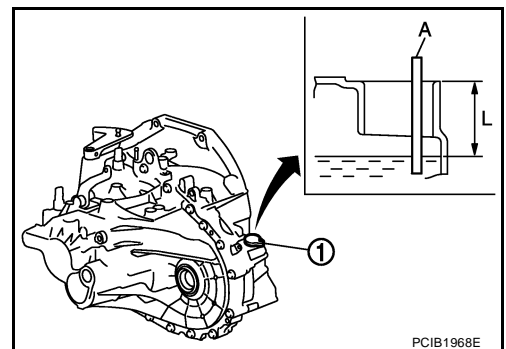

Balancing Wheels

ELS002D9

REMOVAL

1. Remove inner and outer balance weights from the wheel.

CAUTION:

Be careful not to scratch the wheel during removal procedures.

2. Using releasing agent, remove double-faced adhesive tape from the wheel.

CHASSIS AND BODY MAINTENANCE

CAUTION:

- Be careful not to scratch the wheel during removal.
- After removing double-faced adhesive tape, wipe clean traces of releasing agent from the wheel.

WHEEL BALANCE ADJUSTMENT

NOTE:

If a tire balance machine has adhesion balance weight mode settings and drive-in weight mode setting, select and adjust a drive-in weight mode suitable for wheels.

1. Set wheel on wheel balancer using the center hole as a guide. Start the tire balance machine.
2. When inner and outer unbalance values are shown on the wheel balancer indicator, multiply outer unbalance value by 1.6 to determine balance weight that should be used. Select the outer balance weight with a value closest to the calculated value and install it to the designated outer position of, or at the designated angle in relation to the road wheel.

CAUTION:

- Do not install the inner balance weight before installing the outer balance weight.
- Before installing the balance weight, be sure to clean the mating surface of the wheel.

Indicated unbalance value $\times 5/3 =$ balance weight to be installed

Calculation example:

23 g (0.81 oz.) $\times 5/3 = 38.33$ g (1.35 oz.) = 40 g (1.41 oz.) balance weight (closer to calculated balance weight value)

Note that balance weight value must be closer to the calculated balance weight value.

Example:

37.4 g = 35 g (1.23 oz.)

37.5 g = 40 g (1.41 oz.)

- a. Install balance weight in the position shown.
- b. When installing balance weight to wheels, set it into the grooved area on the inner wall of the wheel as shown so that the balance weight center is aligned with the wheel balancer indication position (angle).

CAUTION:

- Always use genuine Nissan adhesion balance weights.
- Balance weights are not reusable; always replace with new ones.
- Do not install more than three sheets of balance weight.

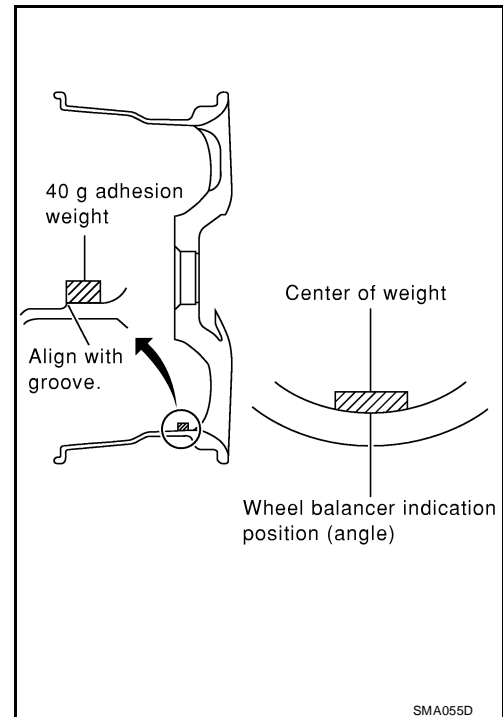
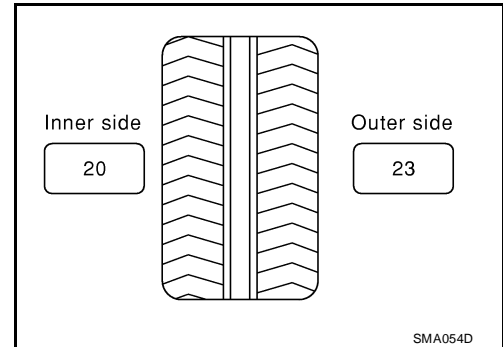

CHASSIS AND BODY MAINTENANCE

- c. If calculated balance weight value exceeds 50 g (1.76 oz.), install two balance weight sheets in line with each other as shown.

CAUTION:

Do not install one balance weight sheet on top of another.

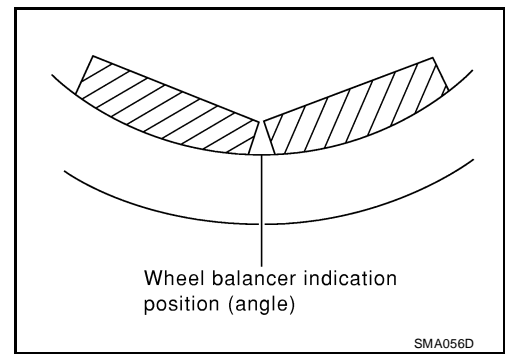

3. Start wheel balancer again.
 4. Install drive-in balance weight on inner side of road wheel in the wheel balancer indication position (angle).

CAUTION:

Do not install more than two balance weights.

5. Start wheel balancer. Make sure that inner and outer residual unbalance values are 5 g (0.18 oz.) each or below.
 ● If either residual unbalance value exceeds 5 g (0.18 oz.), repeat installation procedures.

Wheel Balance (Maximum Allowable Unbalance)

Maximum allowable unbalance	Dynamic (At rim flange)	5 g (0.18 oz.) (one side)
	Static	10 g (0.35 oz.)

Rotation

ELS002DA

- Follow the maintenance schedule for tire rotation service intervals. Refer to [MA-8, "PERIODIC MAINTENANCE"](#) .
- ⇐: Front
- Do not include the T-type spare tire when rotating tires.
- Tighten wheel nuts to specification.

CAUTION:

- **When installing wheels, tighten them diagonally by dividing the work two to three times in order to prevent the wheels from developing any distortion.**
- **Be careful not to tighten wheel nut at torque exceeding the specification to prevent damage of disc rotor.**

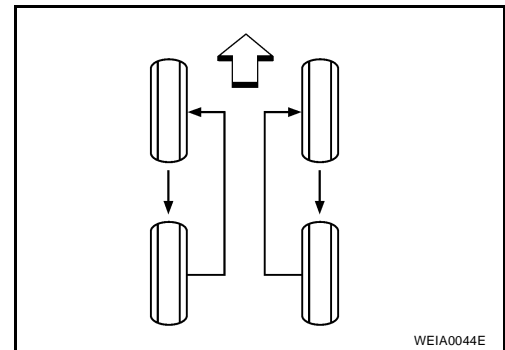

Wheel nut : 108 N·m (11 kg·m, 80 ft·lb)

- After rotating the tires, adjust the tire pressure. Refer to [WT-29, "Tire"](#) .

Checking Brake Fluid Level and Leaks

ELS002DB

- Make sure the fluid level in the reservoir tank is within the standard (between MAX and MIN lines).
- Visually check around the reservoir tank for fluid leakage.
- If fluid level is excessively low, check brake system for fluid leakage.
- Release parking brake lever and see if brake warning lamp goes off. If not, check brake system for fluid leakage.

CHASSIS AND BODY MAINTENANCE

Checking Brake Lines and Cables

ELS002DC

- Check brake fluid lines and parking brake cables for improper attachment, leaks, chafing, abrasions, deterioration, etc.

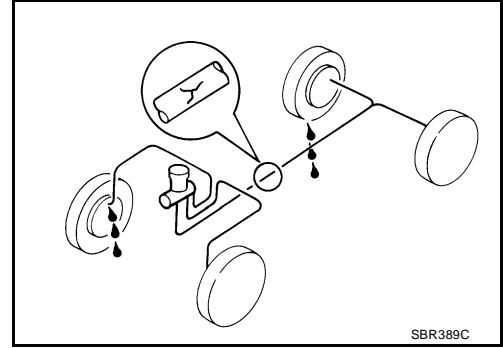

Changing Brake Fluid

ELS002DD

CAUTION:

- Refill using recommended brake fluid. Refer to [MA-14, "RECOMMENDED FLUIDS AND LUBRICANTS"](#) .
 - Never reuse drained brake fluid.
 - Be careful not to splash brake fluid on painted areas; it may cause paint damage. If brake fluid is splashed on painted areas, immediately wipe them with cloth and wash it away with water.
 - Before working, disconnect connectors of ABS actuator and electric unit (control unit) or battery cable from the negative terminal.
1. Connect a vinyl tube to bleed valve.
 2. Depress the brake pedal, loosen the bleed valve, and gradually remove the brake fluid.

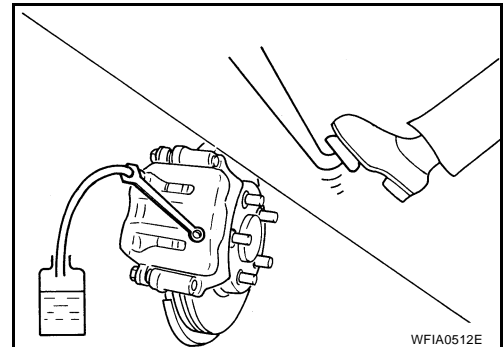

3. Clean inside of reservoir tank, and refill with new brake fluid.
 4. Loosen bleed valve, depress brake pedal slowly to full stroke and then release it. Repeat the procedure every 2 or 3 seconds until the new brake fluid comes out, then close the bleed valve while depressing the brake pedal. Repeat the same procedure for each wheel.
5. Bleed air. Refer to [BR-10, "Bleeding Brake System"](#) .

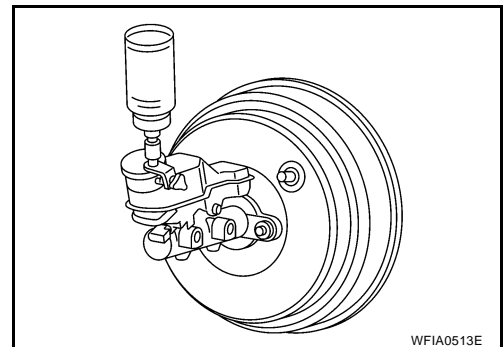

CHASSIS AND BODY MAINTENANCE

Checking Disc Brake

ROTOR

Check the rotor condition and thickness. Resurface or replace the rotor as necessary. Refer to [BR-42, "Front Disc Brake"](#) .

ELS002DE

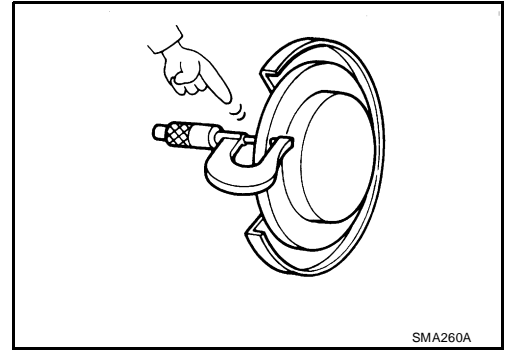

SMA260A

CALIPER

Check the caliper for leakage.

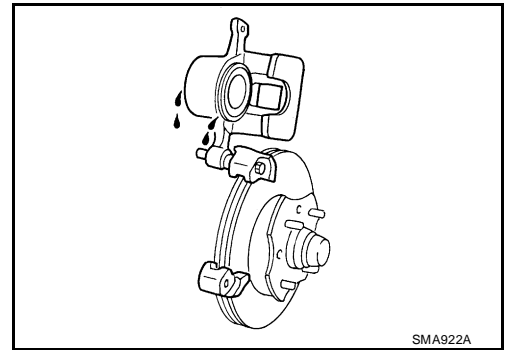

SMA922A

PAD

Check the brake pads for wear or damage. Refer to [BR-23, "PAD WEAR INSPECTION"](#) .

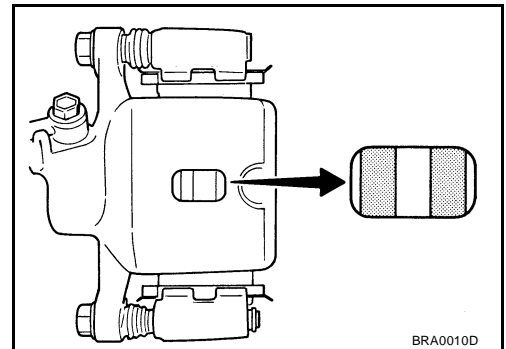

BRA0010D

WHEEL CYLINDER

Check for leakage.

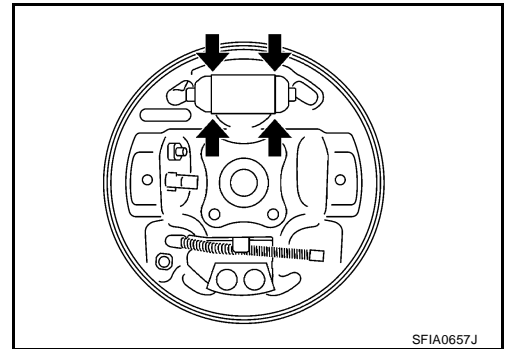

SFIA0657J

A
B
C
D
E
F
G
H
I
J
K
MA
M

CHASSIS AND BODY MAINTENANCE

LINING

Check for lining thickness (A). Refer to [BR-40, "Disassembly and Assembly of Wheel Cylinder"](#) .

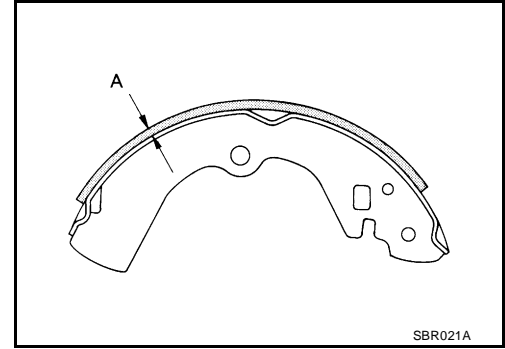

Axle and Suspension Parts

Check front and rear axle and suspension parts for excessive play, cracks, wear or other damage.

- Shake each wheel to check for excessive play.
- Check wheel bearings for smooth operation.
- Check axle and suspension nuts and bolts for looseness.
- Check strut (shock absorber) for oil leakage or other damage.
- Check suspension ball joint for grease leakage and ball joint dust cover for cracks or other damage.

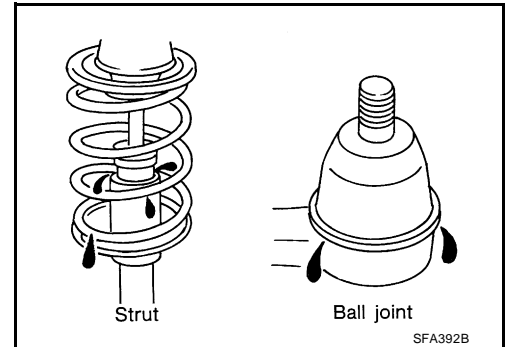
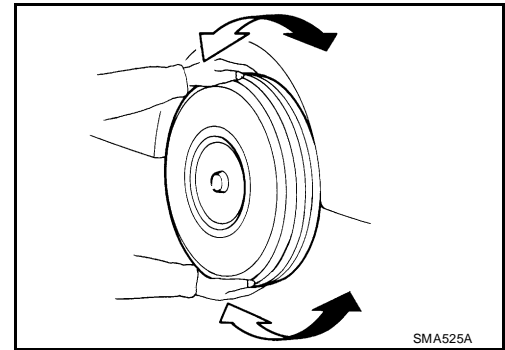

Drive Shaft

Check boot and drive shaft for cracks, wear, damage and grease leakage.

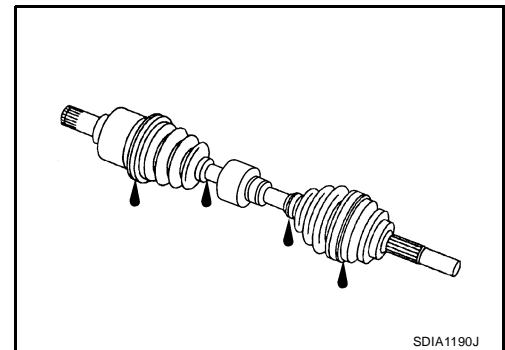

Lubricating Locks, Hinges and Hood Latch

ELS002DH

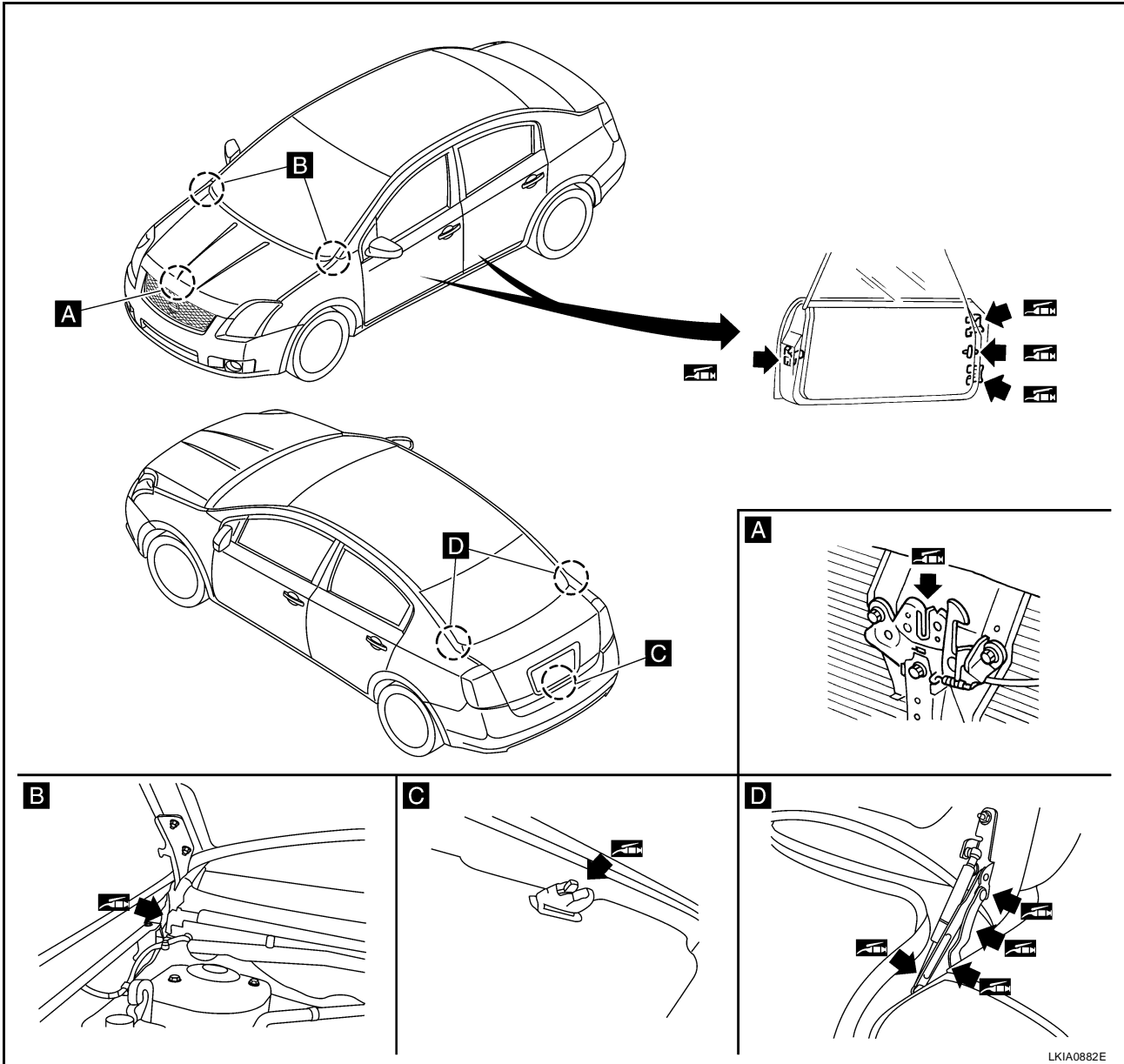

LKIA0882E

Checking Seat Belts, Buckles, Retractors, Anchors and Adjusters

ELS002DI

Check the seat belt buckles, webbing, retractors, anchors and adjusters. Replace any seat belt assembly as necessary. Refer to [SB-8, "Seat Belt Inspection"](#) .

- Check the seat belt anchors for loose bolts, damage, or excessive wear.
- Check the seat belt webbing for any damage, cuts, fraying, or excessive wear.
- Check the retractor for smooth operation.
- Check the function of the buckles by inserting the seat belt tongue and checking for proper engagement of the buckle and press the button on the buckle to check for proper release of the seat belt tongue.

CAUTION:

- **After any collision, inspect all seat belt assemblies, including retractors and other attached components, such as the guide rail set. NISSAN recommends replacing all seat belt assemblies in use during a collision, unless they are not damaged and are inspected to confirm they are operating properly after a minor collision. Also inspect all seat belt assemblies that are not in use during a collision, and replace any components if damaged or not operating properly. The seat belt pre-tensioner should be replaced even if the seat belts are not in use during a frontal collision where the driver and passenger air bags have been deployed.**

A
B
C
D
E
F
G
H
I
J
K
MA

CHASSIS AND BODY MAINTENANCE

- If any component of the seat belt assembly is suspected of being damaged or not operating properly, do not repair the component. Replace the components as an assembly.
- If the seat belt webbing is cut, frayed, or damaged then replace the seat belt assembly.
- Never lubricate the seat belt buckle or tongue.
- When replacing any seat belt assembly always use a Genuine NISSAN seat belt assembly.