

A  
LU

# SECTION LU

## ENGINE LUBRICATION SYSTEM

C

### CONTENTS

D  
E

<b>MR20DE</b>			
<b>PRECAUTIONS</b> .....	<b>2</b>		
Precautions for Supplemental Restraint System (SRS) "AIR BAG" and "SEAT BELT PRE-TENSIONER" .....	2		
<b>PREPARATION</b> .....	<b>3</b>		
Special Service Tools .....	3		
Commercial Service Tools .....	3		
<b>LUBRICATION SYSTEM</b> .....	<b>4</b>		
Lubrication Circuit .....	4		
<b>ENGINE OIL</b> .....	<b>5</b>		
Inspection .....	5		
ENGINE OIL LEVEL .....	5		
ENGINE OIL APPEARANCE .....	5		
ENGINE OIL LEAKAGE .....	5		
OIL PRESSURE CHECK .....	5		
Changing Engine Oil .....	6		
<b>OIL FILTER</b> .....	<b>8</b>		
Removal and Installation .....	8		
REMOVAL .....	8		
INSTALLATION .....	8		
INSPECTION AFTER INSTALLATION .....	8		
<b>SERVICE DATA AND SPECIFICATIONS (SDS)</b> .....	<b>9</b>		
Standard and Limit .....	9		
OIL PRESSURE .....	9		
OIL CAPACITY .....	9		
<b>QR25DE</b>			
<b>PRECAUTIONS</b> .....	<b>10</b>		
Precautions for Supplemental Restraint System			
		(SRS) "AIR BAG" and "SEAT BELT PRE-TENSIONER" .....	10
		<b>PREPARATION</b> .....	<b>11</b>
		Special Service Tools .....	11
		Commercial Service Tools .....	11
		<b>LUBRICATION SYSTEM</b> .....	<b>13</b>
		Lubrication Circuit .....	13
		System Drawing .....	14
		<b>ENGINE OIL</b> .....	<b>15</b>
		Inspection .....	15
		OIL LEVEL .....	15
		ENGINE OIL APPEARANCE .....	15
		OIL LEAKAGE .....	15
		OIL PRESSURE CHECK .....	15
		Changing Engine Oil .....	16
		<b>OIL FILTER</b> .....	<b>17</b>
		Removal and Installation .....	17
		REMOVAL .....	17
		INSTALLATION .....	17
		<b>OIL PUMP</b> .....	<b>18</b>
		Removal and Installation .....	18
		Disassembly and Assembly .....	18
		DISASSEMBLY .....	18
		INSPECTION AFTER DISASSEMBLY .....	18
		ASSEMBLY .....	20
		<b>SERVICE DATA AND SPECIFICATIONS (SDS)</b> .....	<b>21</b>
		Oil Pressure .....	21
		Oil Pump .....	21
		Regulator Valve .....	21
		Oil Capacity .....	21

F  
G  
H  
I  
J  
K  
L  
M

## PRECAUTIONS

PF0:00001

### Precautions for Supplemental Restraint System (SRS) “AIR BAG” and “SEAT BELT PRE-TENSIONER”

EBS00ZB7

The Supplemental Restraint System such as “AIR BAG” and “SEAT BELT PRE-TENSIONER”, used along with a front seat belt, helps to reduce the risk or severity of injury to the driver and front passenger for certain types of collision. This system includes seat belt switch inputs and dual stage front air bag modules. The SRS system uses the seat belt switches to determine the front air bag deployment, and may only deploy one front air bag, depending on the severity of a collision and whether the front occupants are belted or unbelted. Information necessary to service the system safely is included in the SRS and SB section of this Service Manual.

#### **WARNING:**

- **To avoid rendering the SRS inoperative, which could increase the risk of personal injury or death in the event of a collision which would result in air bag inflation, all maintenance must be performed by an authorized NISSAN/INFINITI dealer.**
- **Improper maintenance, including incorrect removal and installation of the SRS, can lead to personal injury caused by unintentional activation of the system. For removal of Spiral Cable and Air Bag Module, see the SRS section.**
- **Do not use electrical test equipment on any circuit related to the SRS unless instructed to in this Service Manual. SRS wiring harnesses can be identified by yellow and/or orange harnesses or harness connectors.**

# PREPARATION

[MR20DE]

PF0:00002

EBS00ZB0

## PREPARATION

### Special Service Tools

The actual shapes of Kent-Moore tools may differ from those of special service tools illustrated here.

Tool number (Kent-Moore No.) Tool name	Description
ST25051001 (J-25695-1) Oil pressure gauge	Measuring oil pressure <b>Maximum measuring range: 2,452 kPa (25 kg/cm<sup>2</sup> , 356 psi)</b>
ST25052000 (J-25695-2) Hose	Adapting oil pressure gauge to oil pan (upper)
KV10115801 (J-38956) Oil filter wrench	Removing oil filter <b>a: 64.3 mm (2.531 in)</b>



NT050

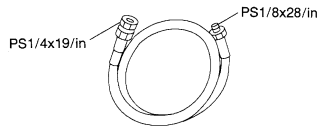

S-NT559

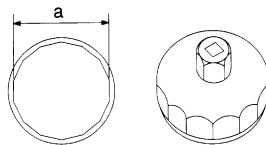

S-NT375

### Commercial Service Tools

EBS00ZB1

Tool name	Description
Power tool	Loosening nuts and bolts
Deep socket	Removing and installing oil pressure sensor <b>a: 26 mm (1.02 in)</b>

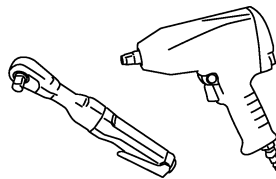

PBIC0190E

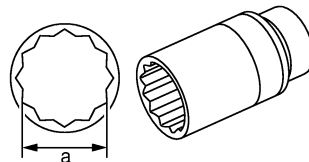

PBIC2072E

# LUBRICATION SYSTEM

[MR20DE]

PF15010

EBS00ZB2

## LUBRICATION SYSTEM

### Lubrication Circuit

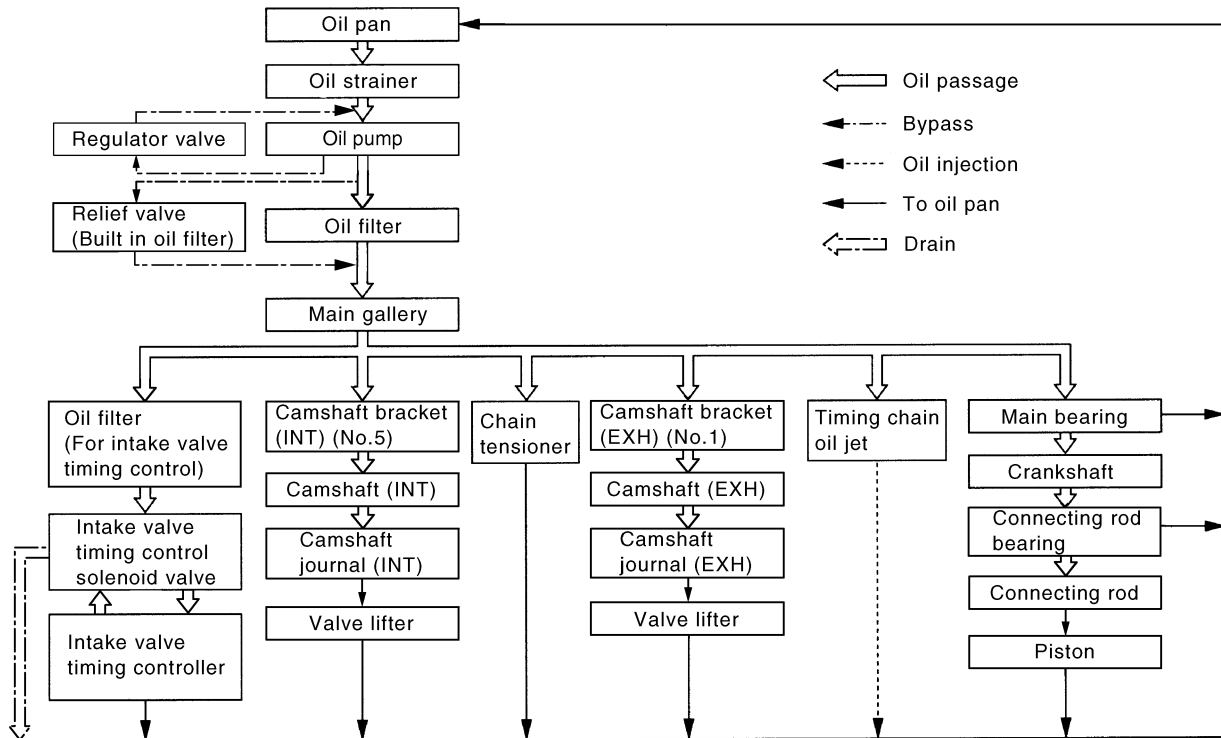
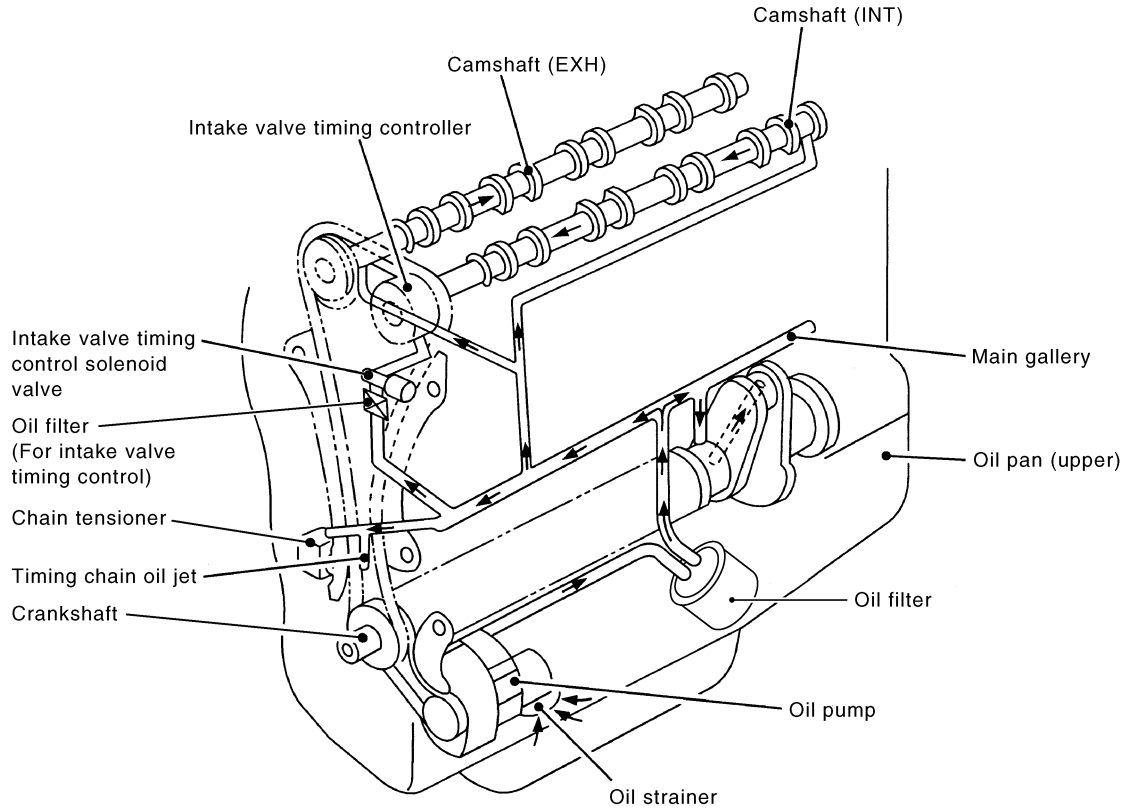

PBIC4575E

## ENGINE OIL

### Inspection ENGINE OIL LEVEL

**NOTE:**

Before starting engine, park vehicle on a level surface and check the engine oil level. If engine is already started, stop it and allow 10 minutes before checking.

1. Pull out oil level gauge and wipe it clean.
2. Insert oil level gauge and make sure the engine oil level is within the range (A) as shown.
3. If it is out of range, adjust it.

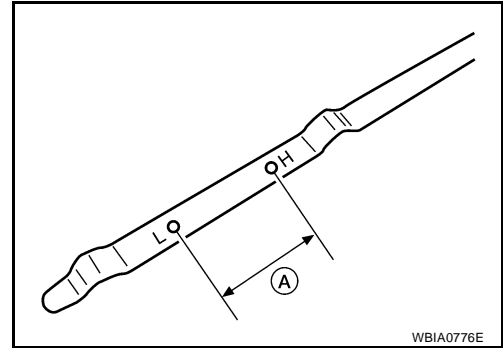

### ENGINE OIL APPEARANCE

- Check engine oil for white turbidity or heavy contamination.
- If engine oil becomes turbid and white, it is highly probable that it is contaminated with engine coolant. Repair or replace damaged parts.

### ENGINE OIL LEAKAGE

Check for engine oil leakage around the following areas:

- Oil pan (upper and lower)
- Oil pan drain plug
- Oil pressure switch
- Oil filter
- Intake valve timing control solenoid valve
- Front cover
- Mating surface between cylinder block and cylinder head
- Mating surface between cylinder head and rocker cover
- Crankshaft oil seals (front and rear)
- Oil filter (for intake valve timing control)

### OIL PRESSURE CHECK

**WARNING:**

- Be careful not to burn yourself, as engine oil may be hot.
- For engine oil pressure check the transaxle should be in “Park position” (CVT models) or “Neutral position” (M/T models), and apply the parking brake securely.

1. Disconnect harness connector at oil pressure switch (1), and remove oil pressure switch using a suitable tool.
  - Oil pan (lower) (2)
  - ← Front

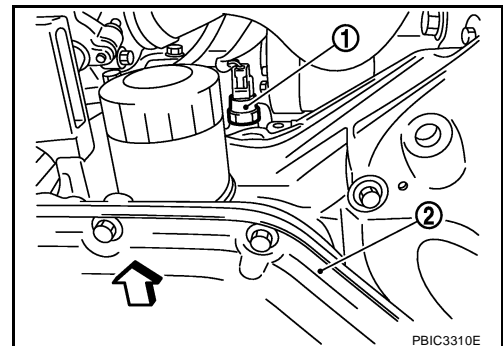

# ENGINE OIL

[MR20DE]

2. Install oil pressure gauge and hose.

**Tool number** : ST25051001 (J-25695-1)  
: ST25052000 (J-25695-2)

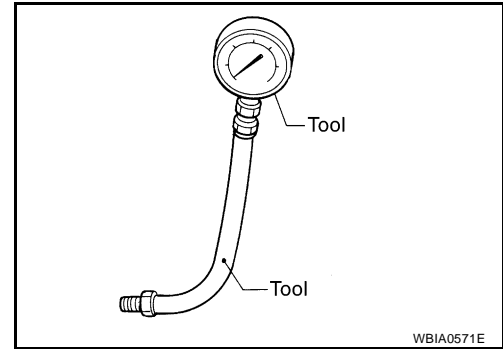

3. Check engine oil level. Refer to [LU-5, "ENGINE OIL LEVEL"](#).
4. Start engine and warm it up to normal operating temperature.
5. Check oil pressure with engine running under no-load.

**NOTE:**

When engine oil temperature is low, engine oil pressure becomes high.

**Engine oil pressure [Engine oil temperature at 80°C (176°F)]**

Engine speed rpm	Approximate discharge pressure kPa (bar, kg/cm <sup>2</sup> , psi)
Idle speed	More than 60 (0.60, 0.61, 9)
2,000	More than 200 (2.0, 2.0, 29)

**If difference is extreme, check oil passage and oil pump for oil leaks.**

6. After the inspections, install oil pressure switch as follows:
  - a. Remove old liquid gasket adhering to oil pressure switch and engine.
  - b. Apply liquid gasket and tighten oil pressure switch to specification.  
**Use Genuine Silicone RTV Sealant or equivalent.** Refer to [GI-44, "Recommended Chemical Products and Sealants"](#).

**Oil pressure switch** : 14.7 N·m (1.5 kg·m, 11 ft·lb)

- c. Check engine oil level. Refer to [LU-5, "ENGINE OIL LEVEL"](#).
- d. After warming up engine, make sure there are no engine leaks of oil with running engine.

## Changing Engine Oil

EBS00ZB4

**WARNING:**

- **Be careful not to burn yourself, as engine oil may be hot.**
  - **Prolonged and repeated contact with used engine oil may cause skin cancer; try to avoid direct skin contact with used engine oil. If skin contact is made, wash thoroughly with soap or hand cleaner as soon as possible.**
1. Warm up engine, park vehicle on a level surface and check for engine oil leakage from engine components. Refer to [LU-5, "ENGINE OIL LEAKAGE"](#).
  2. Stop engine and wait for 10 minutes.

# ENGINE OIL

[MR20DE]

3. Loosen oil filler cap (1) and then remove drain plug (2).
  - Oil filter (3)
  - ← Engine front
4. Drain engine oil.
5. Install drain plug (2) with new washer. Refer to [EM-26, "Components"](#).

**Drain plug torque : 34.3 N·m (3.5 kg-m, 25 ft-lb)**

**CAUTION:**

**Be sure to clean drain plug (2) and install with new washer.**

6. Refill with new engine oil.  
Refer to [MA-14, "RECOMMENDED FLUIDS AND LUBRICANTS"](#).

**CAUTION:**

- **The refill capacity depends on the engine oil temperature and drain time. Use these specifications for reference only.**

- **Always use oil level gauge to determine the proper amount of engine oil in the engine.**

7. Warm up engine and check area around drain plug (2) and oil filter (3) for engine oil leakage.
8. Stop engine and wait for 10 minutes.
9. Check the engine oil level. Refer to [LU-5, "ENGINE OIL LEVEL"](#).

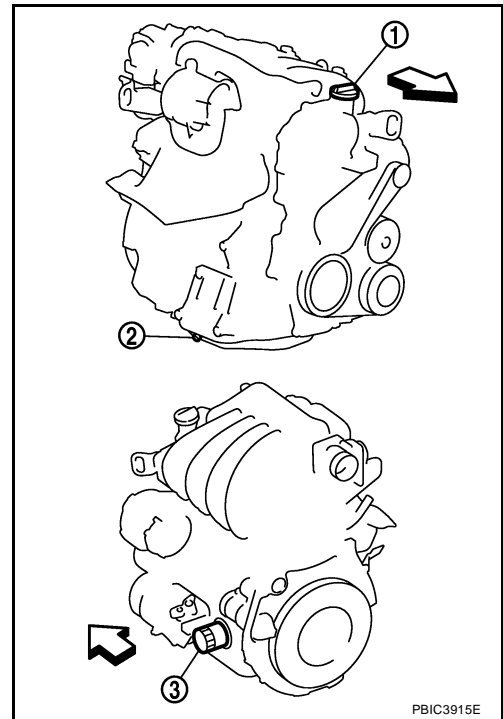

A

LU

C

D

E

F

G

H

I

J

K

L

M

## OIL FILTER

Removal and Installation  
REMOVAL

1. Remove oil filter using Tool (A).

**Tool number** : KV10115801 (J-38956)

- ⇐ Front

**CAUTION:**

- Oil filter is provided with relief valve. Use Genuine NISSAN Oil Filter or equivalent.
- Be careful not to get burned when engine and engine oil may be hot.
- When removing, prepare a shop cloth to absorb any engine oil leakage or spillage.
- Do not allow engine oil to adhere to drive belt.
- Completely wipe off any engine oil that adheres to engine and vehicle.

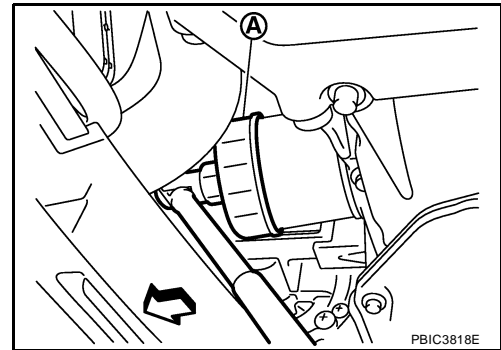

## INSTALLATION

1. Remove foreign materials adhering to the oil filter installation surface.
2. Apply new engine oil to the oil seal contact surface of new oil filter.

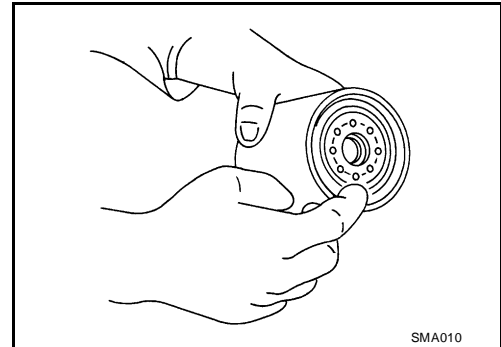

3. Screw oil filter manually until it touches the installation surface, then tighten it by 2/3 turn. Or tighten to specification.

**Oil filter:** : 17.7 N·m (1.8 kg·m, 13 ft·lb)

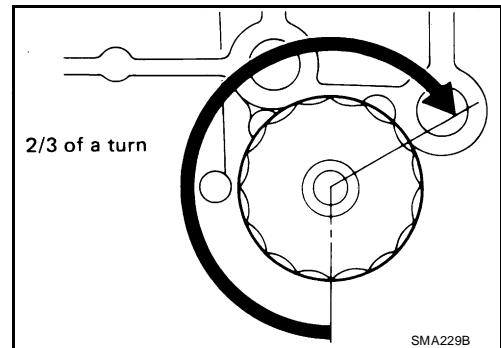

## INSPECTION AFTER INSTALLATION

1. Check the engine oil level. Refer to [LU-5, "ENGINE OIL"](#).
2. Start engine, and make sure there is no leaks of engine oil.
3. Stop engine and wait for 10 minutes.
4. Check the engine oil level and adjust engine oil. Refer to [LU-5, "ENGINE OIL"](#).



# SERVICE DATA AND SPECIFICATIONS (SDS)

[MR20DE]

## SERVICE DATA AND SPECIFICATIONS (SDS)

PFP:00030

### Standard and Limit OIL PRESSURE

EBS00ZB6

Engine speed rpm	Approximate discharge pressure kPa (bar, kg/cm <sup>2</sup> , psi)
Idle speed 2,000	60 (0.60, 0.61, 9) 200 (2.0, 2.0, 29)

### OIL CAPACITY

Unit: ℓ (US qt, Imp qt)

Drain and refill	With oil filter change	Approximately 3.8 (4, 3 3/8)
	Without oil filter change	Approximately 3.6 (3 7/8, 3 1/8)
Dry engine (engine overhaul)		Approximately 4.4 (4 5/8, 3 7/8)

A

LU

C

D

E

F

G

H

I

J

K

L

M

## PRECAUTIONS

PF0:00001

### Precautions for Supplemental Restraint System (SRS) “AIR BAG” and “SEAT BELT PRE-TENSIONER”

EBS00Z7D

The Supplemental Restraint System such as “AIR BAG” and “SEAT BELT PRE-TENSIONER”, used along with a front seat belt, helps to reduce the risk or severity of injury to the driver and front passenger for certain types of collision. This system includes seat belt switch inputs and dual stage front air bag modules. The SRS system uses the seat belt switches to determine the front air bag deployment, and may only deploy one front air bag, depending on the severity of a collision and whether the front occupants are belted or unbelted. Information necessary to service the system safely is included in the SRS and SB section of this Service Manual.

#### **WARNING:**

- To avoid rendering the SRS inoperative, which could increase the risk of personal injury or death in the event of a collision which would result in air bag inflation, all maintenance must be performed by an authorized NISSAN/INFINITI dealer.
- Improper maintenance, including incorrect removal and installation of the SRS, can lead to personal injury caused by unintentional activation of the system. For removal of Spiral Cable and Air Bag Module, see the SRS section.
- Do not use electrical test equipment on any circuit related to the SRS unless instructed to in this Service Manual. SRS wiring harnesses can be identified by yellow and/or orange harnesses or harness connectors.

# PREPARATION

[QR25DE]

PF0:00002

EBS00Z7F

## PREPARATION

### Special Service Tools

The actual shape of the Kent-Moore tools may differ from those tools illustrated here.

Tool number (Kent Moore No.) Tool name	Description
ST25051001 (J-25695-1) Oil pressure gauge	Measuring oil pressure <b>Maximum measuring range:</b> <b>2,452 kPa (25 kg/cm<sup>2</sup> , 356 psi)</b>
ST25052000 (J-25695-2) Hose	Adapting oil pressure gauge to cylinder block
KV10115801 (J-38956) Oil filter wrench	Removing and installing oil filter
KV10111100 (J-37228) Seal cutter	Removing steel oil pan and rear timing chain case
WS39930000 (—) Tube presser	Pressing the tube of liquid gasket

### Commercial Service Tools

EBS00Z7G

# PREPARATION

[QR25DE]

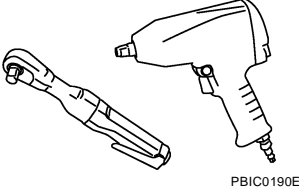
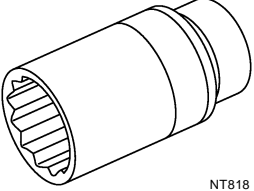
Tool name	Description
<p data-bbox="164 197 272 222">Power tool</p>  <p data-bbox="852 401 922 426">PBIC0190E</p>	<p data-bbox="1013 197 1268 222">Loosening bolts and nuts</p>
<p data-bbox="164 432 289 457">Deep socket</p>  <p data-bbox="852 632 898 657">NT818</p>	<p data-bbox="1013 432 1455 489">Removing and installing oil pressure sensor Deep socket 26 mm, 3/8 drive</p>

### LUBRICATION SYSTEM

PFP:15010

### Lubrication Circuit

EBS00Z7H

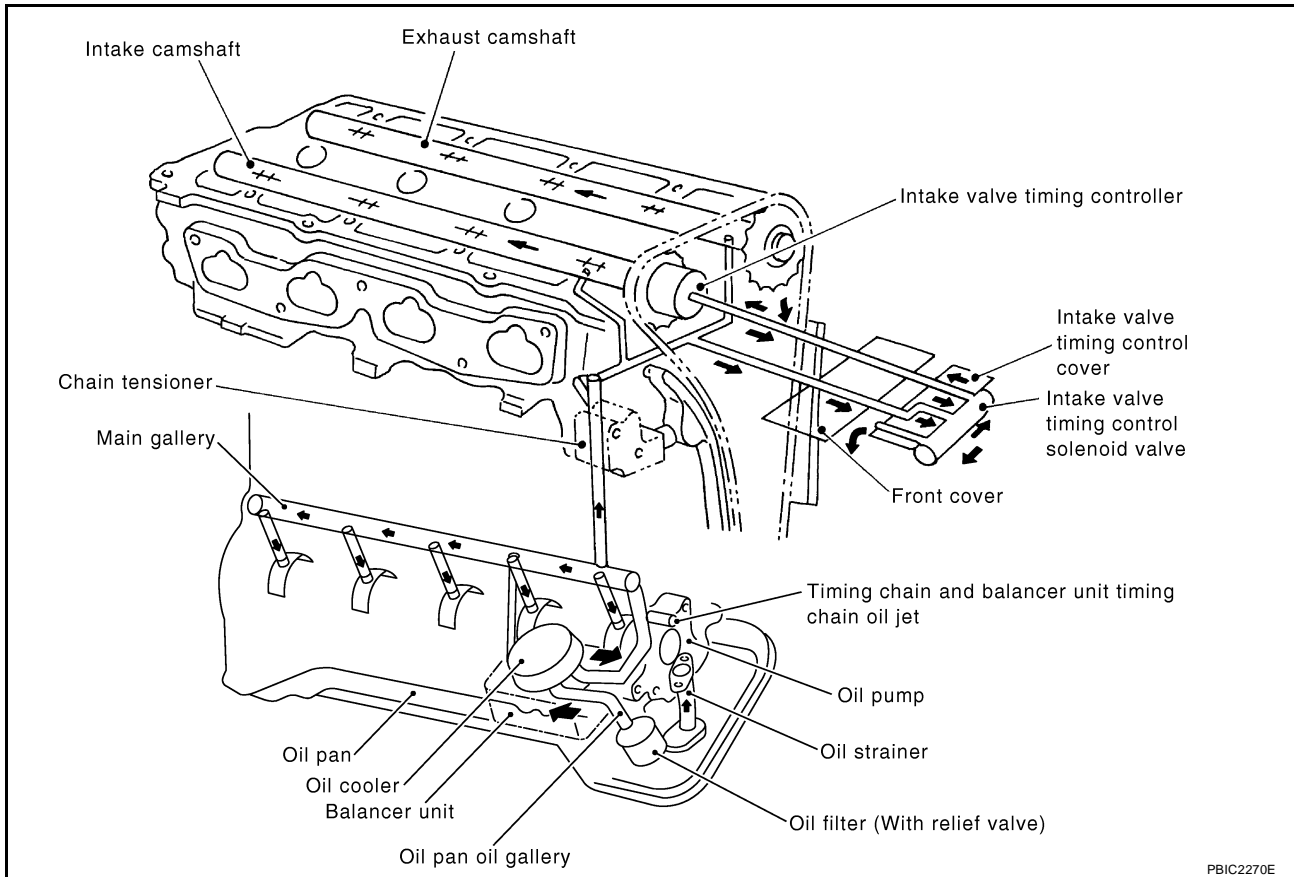

PBIC2270E

A

LU

C

D

E

F

G

H

I

J

K

L

M

# LUBRICATION SYSTEM

[QR25DE]

## System Drawing

EBS00Z71

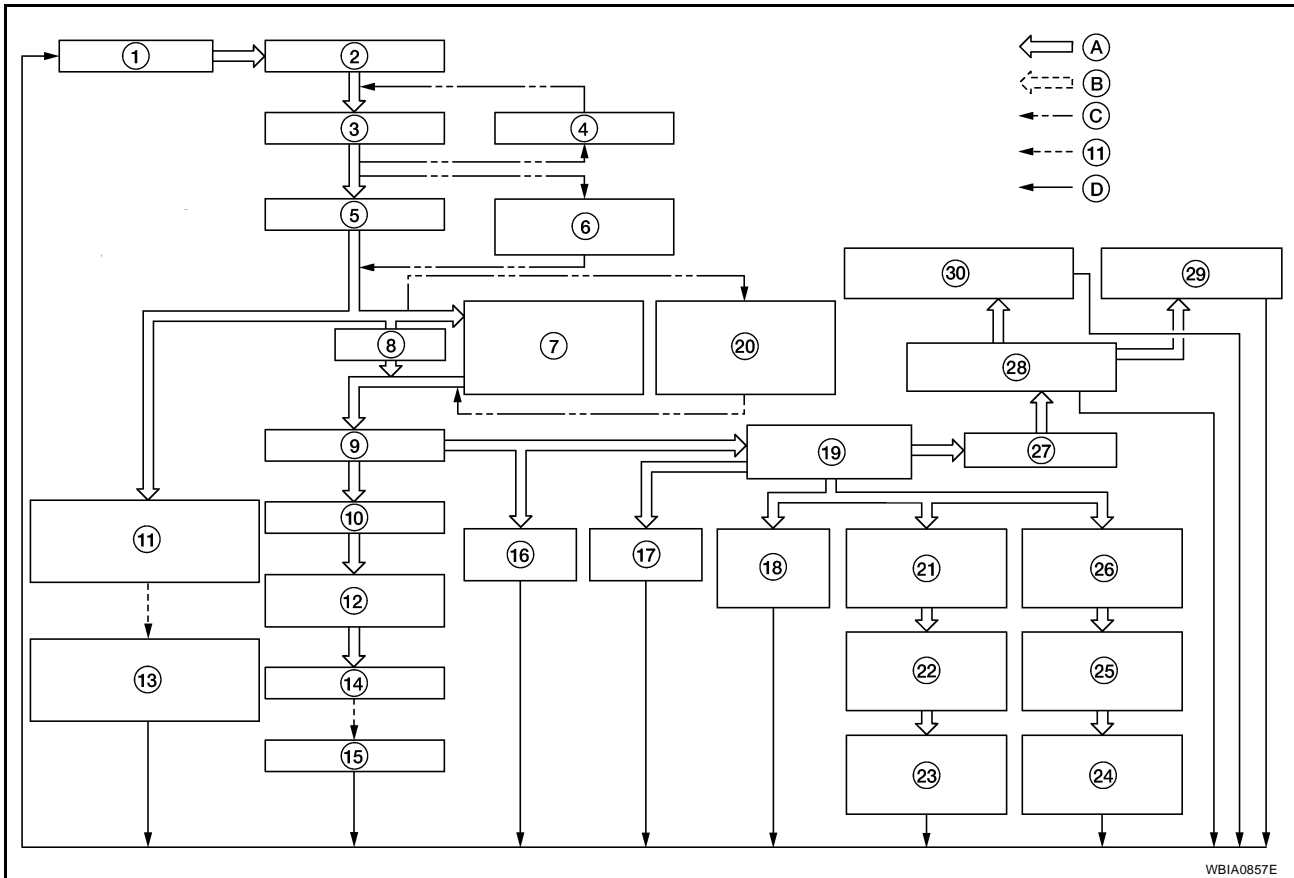

WBIA0857E

- |   |   |  |
|---|---|--|
| 1. Oil pan                                      | 2. Oil strainer   | 3. Oil pump                                    |
| 4. Regulator valve                              | 5. Oil filter   | 6. Relief valve (Built in oil filter)          |
| 7. Oil cooler                                   | 8. Bypass   | 9. Connecting rod bearing                      |
| 10. Main bearing                                | 11. Timing chain and balancer unit timing chain oil jet | 12. Connecting rod bearing                     |
| 13. Timing chain and balancer unit timing chain | 14. Connecting Rod                                      | 15. Piston                                     |
| 16. Balancer unit                               | 17. Chain tensioner                                     | 18. Camshaft bracket (No.1)                    |
| 19. Cylinder head oil gallery                   | 20. Relief valve  | 21. Intake camshaft bracket (No.2)             |
| 22. Intake camshaft oil passage                 | 23. Intake camshaft journal                             | 24. Exhaust camshaft journal                   |
| 25. Exhaust camshaft oil passage                | 26. Exhaust camshaft bracket (No.2)                     | 27. Front cover                                |
| 28. Intake valve timing control cover           | 29. Intake valve timing controller                      | 30. Intake valve timing control solenoid valve |
| A. Oil passage                                  | B. Return oil passage                                   | C. Bypass                                      |
| D. To oil pan                                   |   |  |

## ENGINE OIL

### Inspection OIL LEVEL

- Before starting the engine, check the oil level. If the engine is already started, stop it and allow 10 minutes before checking.
- Check that the oil level is within the range on the dipstick.
- If it is out of range, add oil as necessary. Refer to [GI-44, "Recommended Chemical Products and Sealants"](#) .

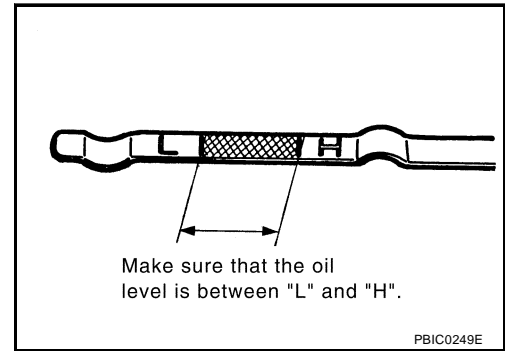

### ENGINE OIL APPEARANCE

- Check engine oil for white milky or excessive contamination.
- If engine oil becomes milky, it is highly probable that it is contaminated with engine coolant. Repair or replace damaged parts.

### OIL LEAKAGE

Check for oil leakage around the following areas:

- Oil pan
- Oil pan drain plug
- Oil pressure sensor
- Oil filter
- IVTC cover
- Front cover
- Mating surface between cylinder block and cylinder head
- Mating surface between cylinder head and rocker cover
- Crankshaft oil seal

### OIL PRESSURE CHECK

#### WARNING:

- **Be careful not to burn yourself, as engine oil may be hot.**
- **For M/T models, put the gearshift lever in the Neutral "N" position. For CVT models, put the selector lever in the Park "P" position.**

1. Check engine oil level. Refer to [LU-15, "OIL LEVEL"](#) .
2. Remove undercover using power tool.
3. Disconnect oil pressure sensor harness connector at oil pressure sensor, and remove oil pressure sensor.

#### CAUTION:

**Do not drop or shock oil pressure sensor.**

4. Start engine and warm it up to normal operating temperature.
5. Check oil pressure with engine running under no-load, using Tool

**Tool numbers** : ST25051001 (J-25695-1)  
: ST25052000 (J-25695-2)

#### NOTE:

When engine oil temperature is low, engine oil pressure becomes high.

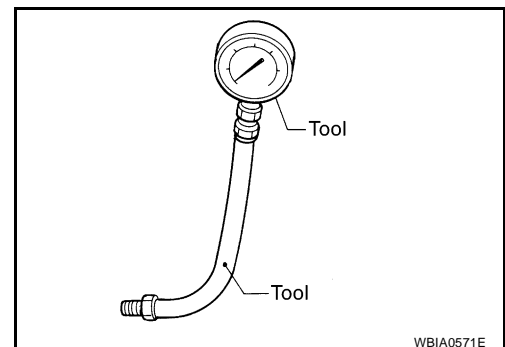

# ENGINE OIL

[QR25DE]

## Engine oil pressure [Oil temperature 80 °C (176 °F)]

Engine speed (rpm)	Idle speed	2,000	6,000
Engine pressure kPa (kg/cm <sup>2</sup> , psi)	Approx. 98 (1.0, 14) or more	Approx. 294 (3.0, 43) or more	Approx. 392 (4.0, 57) or more

**If difference is extreme, check oil passage and oil pump for oil leaks.**

6. After the inspections, install oil pressure sensor as follows:
  - a. Remove old liquid gasket adhering to oil pressure sensor and engine.
  - b. Apply liquid gasket and tighten oil pressure sensor to the specification.  
**Use Genuine RTV Silicone Sealant or equivalent. Refer to [GI-44, "Recommended Chemical Products and Sealants"](#).**

**Oil pressure sensor torque : 14.7 N·m (1.5 kg·m, 11 ft·lb)**

- c. After warming up engine, make sure there is no leakage of engine oil with running engine.

## Changing Engine Oil

EBS00Z7K

### WARNING:

- **Be careful not to burn yourself, as the engine oil may be hot.**
  - **Prolonged and repeated contact with used engine oil may cause skin cancer: try to avoid direct skin contact with used oil. If skin contact is made, wash thoroughly with soap or hand cleaner as soon as possible.**
1. Position the vehicle so it is level on the hoist.
  2. Warm up the engine, and check for oil leaks from the engine.
  3. Stop engine and wait for 10 minutes.
  4. Remove the oil pan drain plug and oil filler cap.
  5. Drain the engine oil.
  6. Install the oil pan drain plug with a new washer and refill the engine with new engine oil.

**Oil specification and capacity : Refer to [GI-44, "Recommended Chemical Products and Sealants"](#).**

**Oil pan drain plug : 34.3 N·m (3.5 kg·m, 25 ft·lb)**

### Oil Capacity (Approximate)

Drain and refill	With oil filter change	4.3 ℓ (4 1/2 US qt, 3 3/4 Imp qt)
	Without oil filter change	4.0 ℓ (4 1/4 US qt, 3 1/2 Imp qt)
Dry engine (engine overhaul)		4.6 ℓ (4 7/8 US qt, 4 Imp qt)

### CAUTION:

- **Be sure to clean the drain plug and install using a new washer.**
  - **The refill capacity depends on the oil temperature and drain time. Use these specifications for reference only.**
  - **Always use the dipstick to determine when the proper amount of oil is in the engine.**
7. Warm up the engine and check the area around the drain plug and oil filter for oil leakage.
  8. Stop the engine and wait for 10 minutes.
  9. Check the oil level using the dipstick.

### CAUTION:

**Do not overfill the engine oil.**



## OIL FILTER

### Removal and Installation

#### REMOVAL

1. Remove the oil filter using Tool.

**Tool number** : KV10115801 (J-38956)

**CAUTION:**

- Be careful not to get burned when the engine and engine oil are hot.
- When removing, prepare a shop cloth to absorb any oil leakage or spillage.
- Do not allow engine oil to adhere to the drive belts.
- Completely wipe off any oil that adheres to the engine and the vehicle.
  
- The oil filter has a built in pressure relief valve. Use a genuine NISSAN oil filter or equivalent

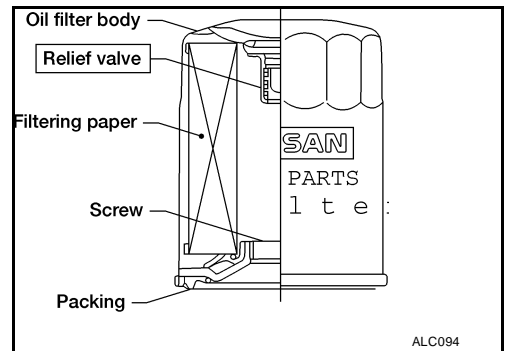
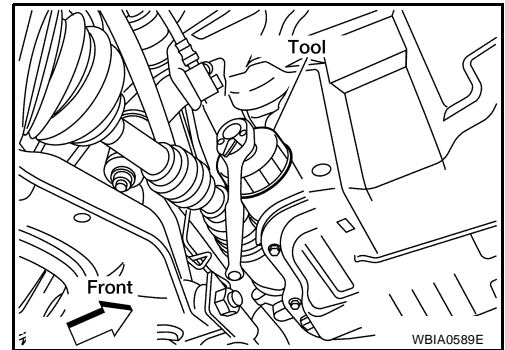

#### INSTALLATION

1. Clean off any foreign materials adhering to the oil filter installation surface.
2. Apply engine oil to the oil seal surface of the new oil filter.

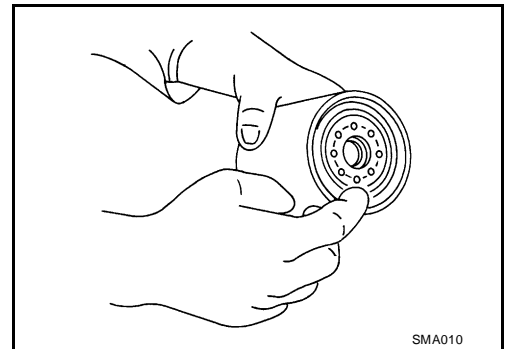

3. Screw the new oil filter manually until it touches the installation surface, then tighten it by 2/3 turn. Or tighten to specification below.

**Oil filter** : 17.6 N·m (1.8 kg·m, 13 ft·lb)

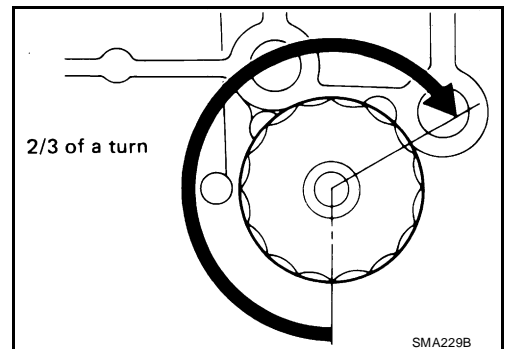

4. Check oil level and add engine oil as necessary. Refer to [LU-15, "ENGINE OIL"](#).
5. After warming up the engine, check for oil leaks.

A  
C  
D  
E  
F  
G  
H  
I  
J  
K  
L  
M

LU

## OIL PUMP

### Removal and Installation

- Remove the front cover. Refer to [EM-161, "REMOVAL"](#).

### Disassembly and Assembly

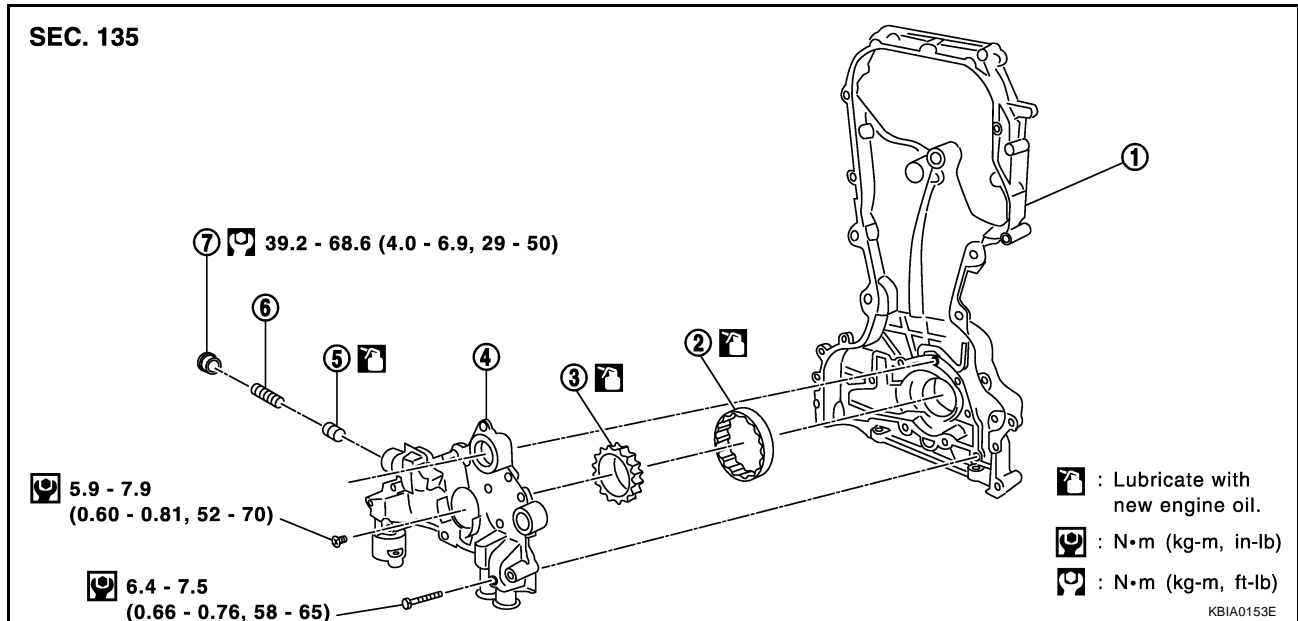

- |                   |                    |                |
|-------------------|--------------------|----------------|
| 1. Front cover    | 2. Outer rotor     | 3. Inner rotor |
| 4. Oil pump cover | 5. Regulator valve | 6. Spring      |
| 7. Regulator plug |                    |                |

### CAUTION:

Before installation, apply new engine oil to the parts as instructed in the figure above.

### DISASSEMBLY

- Remove the oil pump cover.
- Remove inner rotor and outer rotor from front cover.
- After removing regulator plug, remove regulator spring and regulator valve.

### INSPECTION AFTER DISASSEMBLY

Measure the clearance of the oil pump parts.

- Measure clearance with feeler gauge.
- Clearance between outer rotor and oil pump body (position 1).  
**Standard : 0.114 - 0.179 mm (0.0045 - 0.0070 in)**
- Tip clearance between inner rotor and outer rotor (position 2).  
**Standard : Below 0.220 mm (0.0087 in)**

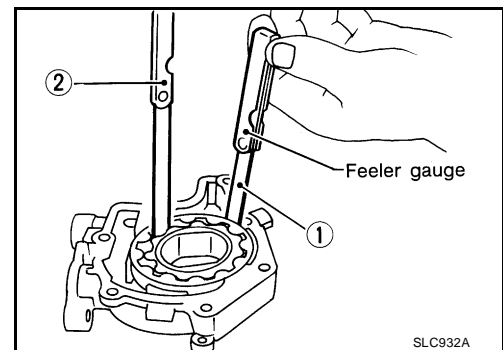

# OIL PUMP

[QR25DE]

- Measure clearance with feeler gauge and straightedge.
- Side clearance between inner rotor and oil pump body (position 3).

**Standard : 0.030 - 0.070 mm (0.0012 - 0.0028 in)**

- Side clearance between outer rotor and oil pump body (position 4).

**Standard : 0.060 - 0.110 mm (0.0024 - 0.0043 in)**

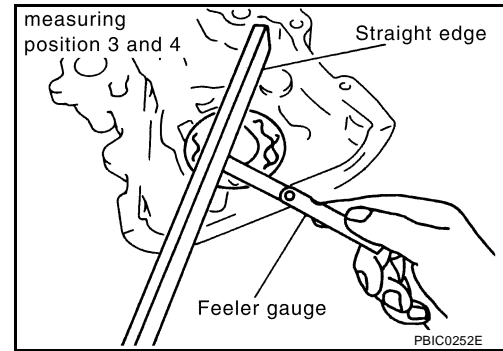

- Calculate the clearance between inner rotor and oil pump body as follows:

1. Measure the outer diameter of protruded portion of inner rotor (Position 5).

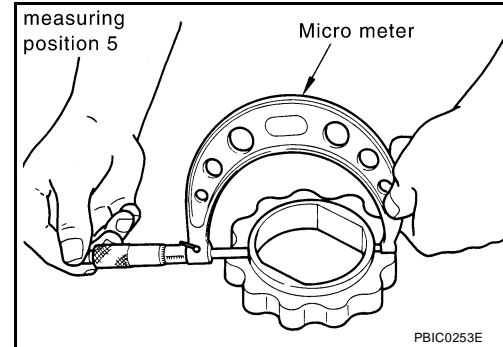

2. Measure the inner diameter of oil pump body with inside micrometer (Position 6).

(Clearance) = (Inner diameter of oil pump body) – (Outer diameter of inner rotor).

**Standard : 0.035 - 0.070 mm (0.0014 - 0.0028 in)**

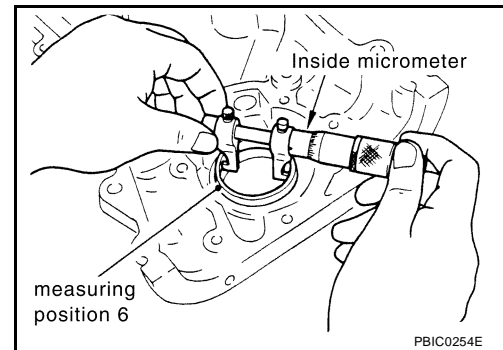

- Regulator valve clearance:  
(Clearance) = D1 (Valve hole diameter) – D2 (Outer diameter of valve)

**Standard : 0.040 - 0.097 mm (0.0016 - 0.0038 in)**

**CAUTION:**

**Coat regulator valve with engine oil.  
Check that it falls smoothly into the valve hole by its own weight.**

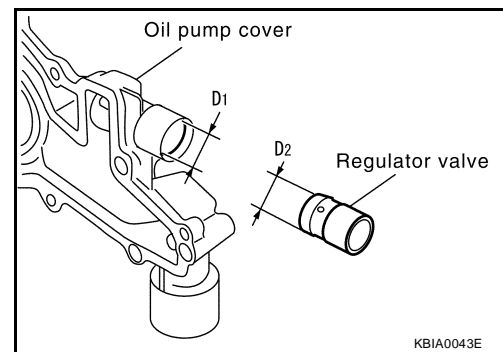

# OIL PUMP

[QR25DE]

## ASSEMBLY

- Assembly is in the reverse order of disassembly.
- Install the inner rotor and outer rotor with the punched marks on the oil pump cover side.

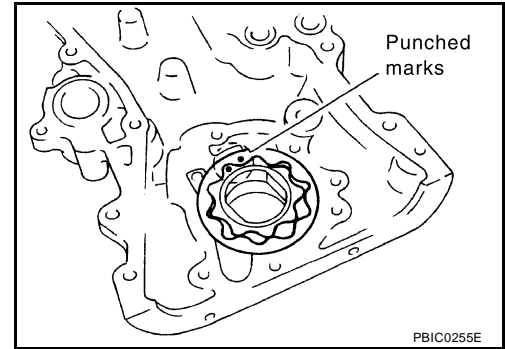

# SERVICE DATA AND SPECIFICATIONS (SDS)

[QR25DE]

## SERVICE DATA AND SPECIFICATIONS (SDS)

PF0:00030

### Oil Pressure

EBS00Z70

Engine speed rpm	Approximate discharge pressure kPa (kg/cm <sup>2</sup> , psi)
Idle speed	More than 98 (1.0, 14)
2,000	294 (3.0, 43)
6,000	392 (4.0, 57)

### Oil Pump

EBS00Z7P

Unit: mm (in)

Body to outer rotor radial clearance	0.114 - 0.179 (0.0045 - 0.0070)
Inner rotor to outer rotor tip clearance	Below 0.220 (0.0087)
Body to inner rotor axial clearance	0.030 - 0.070 (0.0012 - 0.0028)
Body to outer rotor axial clearance	0.060 - 0.110 (0.0024 - 0.0043)
Inner rotor to oil pump body clearance	0.035 - 0.070 (0.0014 - 0.0028)

### Regulator Valve

EBS00Z7Q

Unit: mm (in)

Regulator valve to oil pump cover clearance	0.040 - 0.097 (0.0016 - 0.0038)
---	---------------------------------

### Oil Capacity

EBS00Z7R

Unit: ℓ (US qt, Imp qt)

Drain and refill	With oil filter change	Approximately 4.3 (4 1/2, 3 3/4)
	Without oil filter change	Approximately 4.0 (4 1/4, 3 1/2)
Dry engine (engine overhaul)		Approximately 4.6 (4 7/8, 4)

