

LT
SECTION
LIGHTING SYSTEM

A
B
C

CONTENTS

<p>PRECAUTIONS 4</p> <p> Precautions for Supplemental Restraint System (SRS) "AIR BAG" and "SEAT BELT PRE-TENSIONER" 4</p> <p>HEADLAMP (FOR USA) 5</p> <p> Component Parts and Harness Connector Location... 5</p> <p> System Description 5</p> <p> OUTLINE 5</p> <p> HEADLAMP OPERATION 6</p> <p> COMBINATION SWITCH READING FUNCTION... 6</p> <p> CAN COMMUNICATION SYSTEM DESCRIPTION 6</p> <p> Schematic 7</p> <p> Wiring Diagram 8</p> <p> Terminals and Reference Values for BCM 12</p> <p> Terminals and Reference Values for IPDM E/R 12</p> <p> How to Perform Trouble Diagnoses 12</p> <p> Preliminary Check 12</p> <p> CHECK POWER SUPPLY AND GROUND CIRCUIT FOR BCM 12</p> <p> CHECK POWER SUPPLY AND GROUND CIRCUIT FOR IPDM E/R 12</p> <p> CONSULT-III Function (BCM) 12</p> <p> WORK SUPPORT 12</p> <p> DATA MONITOR 12</p> <p> ACTIVE TEST 13</p> <p> SELF-DIAGNOSTIC RESULTS 13</p> <p> CONSULT-III Function (IPDM E/R) 13</p> <p> DATA MONITOR 14</p> <p> ACTIVE TEST 14</p> <p> Headlamp High Beam Does Not Illuminate (Both Sides) 14</p> <p> Headlamp High Beam Does Not Illuminate (One Side) 17</p> <p> High Beam Indicator Lamp Does Not Illuminate ... 18</p> <p> Headlamp Low Beam Does Not Illuminate (Both Sides) 18</p> <p> Headlamp Low Beam Does Not Illuminate (One Side) 21</p> <p> Headlamps Do Not Turn OFF 22</p>	<p> Aiming Adjustment 23</p> <p> PREPARATION BEFORE ADJUSTING 23</p> <p> LOW BEAM AND HIGH BEAM 23</p> <p> ADJUSTMENT USING AN ADJUSTMENT SCREEN (LIGHT/DARK BORDERLINE) 24</p> <p> Bulb Replacement 25</p> <p> HEADLAMP (HIGH/LOW) 25</p> <p> HEADLAMP (HIGH/LOW) SE-R 25</p> <p> PARKING (CLEARANCE) LAMP 25</p> <p> FRONT TURN SIGNAL LAMP 25</p> <p> FRONT TURN SIGNAL LAMP 25</p> <p> Removal and Installation 25</p> <p> REMOVAL 25</p> <p> INSTALLATION 25</p> <p> Disassembly and Assembly 26</p> <p> DISASSEMBLY 26</p> <p> ASSEMBLY 26</p> <p>HEADLAMP (FOR CANADA) - DAYTIME LIGHT SYSTEM - 27</p> <p> Component Parts and Harness Connector Location.. 27</p> <p> System Description 27</p> <p> OUTLINE 27</p> <p> HEADLAMP OPERATION 28</p> <p> COMBINATION SWITCH READING FUNCTION.. 29</p> <p> CAN Communication System Description 29</p> <p> Schematic 30</p> <p> Wiring Diagram — DTRL — 31</p> <p> Terminals and Reference Values for BCM 35</p> <p> Terminals and Reference Values for IPDM E/R 35</p> <p> How to Perform Trouble Diagnoses 35</p> <p> Preliminary Check 35</p> <p> CHECK BCM CONFIGURATION 35</p> <p> CHECK POWER SUPPLY AND GROUND CIRCUIT FOR BCM 35</p> <p> CHECK POWER SUPPLY AND GROUND CIRCUIT FOR IPDM E/R 35</p> <p> CONSULT-III Function (BCM) 35</p> <p> CONSULT-III Function (IPDM E/R) 35</p> <p> Daytime Light Control Does Not Operate Properly (High Beam Headlamps Operate Properly) 35</p>
---	--

D
E
F
G
H
I
J
LT

L
M

Aiming Adjustment	37	LIGHTING AND TURN SIGNAL SWITCH	62
Bulb Replacement	37	Removal and Installation	62
Removal and Installation	37	REMOVAL	62
Disassembly and Assembly	37	INSTALLATION	62
FRONT FOG LAMP	38	HAZARD SWITCH	63
Component Parts and Harness Connector Location..	38	Removal and Installation	63
System Description	38	REMOVAL	63
OUTLINE	38	INSTALLATION	63
FOG LAMP OPERATION	38	COMBINATION SWITCH	64
COMBINATION SWITCH READING FUNCTION..	39	Wiring Diagram — COMBSW —	64
CAN Communication System Description	39	Combination Switch Reading Function	65
Wiring Diagram — F/FOG —	40	Terminals and Reference Values for BCM	65
Terminals and Reference Values for BCM	42	CONSULT-III Function (BCM)	65
Terminals and Reference Values for IPDM E/R	42	Combination Switch Inspection	65
How to Proceed With Trouble Diagnosis	42	Removal and Installation	67
Preliminary Check	42	STOP LAMP	68
CHECK POWER SUPPLY AND GROUND CIR-		Wiring Diagram — STOP/L —	68
CUIT FOR BCM	42	Bulb Replacement of High-Mounted Stop Lamp	69
CHECK POWER SUPPLY AND GROUND CIR-		Bulb Replacement of Rear Combination Lamp for	
CUIT FOR IPDM E/R	42	Stop Lamp	69
CONSULT-III Function (BCM)	42	Removal and Installation of High-Mounted Stop	
CONSULT-III Function (IPDM E/R)	42	Lamp, All Except SE-R	69
Front Fog lamps Do Not Illuminate (Both Sides) ...	42	REMOVAL	69
Front Fog Lamp Does Not Illuminate (One Side) ...	45	INSTALLATION	69
Aiming Adjustment	46	Removal and Installation of High-Mounted Stop	
Bulb Replacement	46	Lamp, SE-R	69
Removal and Installation, All Except SE-R	46	REMOVAL	69
REMOVAL	46	INSTALLATION	69
INSTALLATION	47	Removal and Installation of Rear Combination	
Removal and Installation, SE-R	47	Lamp for Stop Lamp	69
REMOVAL	47	BACK-UP LAMP	70
INSTALLATION	47	Wiring Diagram — BACK/L —	70
TURN SIGNAL AND HAZARD WARNING LAMPS..	48	Bulb Replacement	71
Component Parts and Harness Connector Location..	48	Removal and Installation	71
System Description	48	PARKING, LICENSE PLATE AND TAIL LAMPS	72
TURN SIGNAL OPERATION	48	Component Parts and Harness Connector Location..	72
HAZARD LAMP OPERATION	49	System Description	72
REMOTE KEYLESS ENTRY SYSTEM OPERA-		OPERATION BY LIGHTING SWITCH	72
TION	50	COMBINATION SWITCH READING FUNCTION..	73
COMBINATION SWITCH READING FUNCTION..	50	EXTERIOR LAMP BATTERY SAVER CONTROL..	73
CAN Communication System Description	50	CAN Communication System Description	73
Schematic	51	Schematic	74
Wiring Diagram — TURN —	52	Wiring Diagram — TAIL/L —	75
Terminals and Reference Values for BCM	56	Terminals and Reference Values for BCM	78
How to Proceed With Trouble Diagnosis	56	Terminals and Reference Values for IPDM E/R	78
Preliminary Check	56	How to Proceed With Trouble Diagnosis	78
CHECK POWER SUPPLY AND GROUND CIR-		Preliminary Check	78
CUIT FOR BCM	56	CHECK POWER SUPPLY AND GROUND CIR-	
CONSULT-III Function (BCM)	56	CUIT FOR BCM	78
Turn Signals Do Not Operate	56	CHECK POWER SUPPLY AND GROUND CIR-	
Front Turn Signal Lamp Does Not Operate	56	CUIT FOR IPDM E/R	78
Rear Turn Signal Lamp Does Not Operate	57	CONSULT-III Function (BCM)	78
Hazard Warning Lamp Does Not Operate But Turn		CONSULT-III Function (IPDM E/R)	78
Signal Lamp Operates	59	Parking, License Plate and Tail Lamps Do Not Illu-	
Turn Signal Indicator Lamp Does Not Operate	60	minate	78
Bulb Replacement of Front Turn Signal Lamp	61	Parking, License Plate and Tail Lamps Do Not Illu-	
Bulb Replacement of Rear Turn Signal Lamp	61	minate	78
Removal and Installation of Front Turn Signal Lamp..	61	Parking, License Plate and Tail Lamps Do Not Illu-	
Removal and Installation of Rear Turn Signal Lamp..	61	minate	78

Parking, License Plate and Tail Lamps Do Not Turn OFF (After Approx. 10 Minutes)	84	Schematic	93	
Bulb Replacement	85	Wiring Diagram — INT/L —	94	A
PARKING LAMP	85	Terminals and Reference Values for BCM	98	
LICENSE PLATE LAMP	85	How to Proceed With Trouble Diagnosis	98	
TAIL LAMP	85	Preliminary Check	98	B
Removal and Installation	85	CHECK POWER SUPPLY AND GROUND CIR- CUIT FOR BCM	98	
PARKING LAMP	85	CONSULT-III Function (BCM)	98	C
LICENSE PLATE LAMP	85	WORK SUPPORT	98	
TAIL LAMP	85	DATA MONITOR	98	
REAR COMBINATION LAMP	86	ACTIVE TEST	99	
Components	86	Interior Room Lamp Control Does Not Operate	99	D
Bulb Replacement	86	Bulb Replacement	100	
Removal and Installation	86	ROOM LAMP	100	
REMOVAL	86	Removal and Installation	101	E
INSTALLATION	87	ROOM LAMP	101	
Disassembly and Assembly	87	ILLUMINATION	102	
DISASSEMBLY	87	System Description	102	F
ASSEMBLY	87	ILLUMINATION OPERATION BY LIGHTING		
INTERIOR LAMP	88	SWITCH	102	
Map lamp	88	CAN Communication System Description	103	G
BULB REPLACEMENT	88	Schematic	104	
REMOVAL AND INSTALLATION	88	Wiring Diagram — ILL —	105	
Luggage Compartment Lamp	88	Bulb Replacement	110	
BULB REPLACEMENT	88	GLOVE BOX LAMP	110	H
REMOVAL AND INSTALLATION	88	MOOD LAMP	110	
INTERIOR ROOM LAMP	89	Removal and Installation	110	
Component Parts and Harness Connector Location..	89	MOOD LAMP	110	I
System Description	89	BULB SPECIFICATIONS	111	
POWER SUPPLY AND GROUND	89	Headlamp	111	
SWITCH OPERATION	90	Exterior Lamp	111	J
INTERIOR ROOM LAMP TIMER OPERATION..	91	Interior Lamp/Illumination	111	
INTERIOR LAMP BATTERY SAVER CONTROL..	92			

LT

L

M

PRECAUTIONS

PRECAUTIONS

PF0:00011

Precautions for Supplemental Restraint System (SRS) “AIR BAG” and “SEAT BELT PRE-TENSIONER”

EKS00JMA

The Supplemental Restraint System such as “AIR BAG” and “SEAT BELT PRE-TENSIONER”, used along with a front seat belt, helps to reduce the risk or severity of injury to the driver and front passenger for certain types of collision. This system includes seat belt switch inputs and dual stage front air bag modules. The SRS system uses the seat belt switches to determine the front air bag deployment, and may only deploy one front air bag, depending on the severity of a collision and whether the front occupants are belted or unbelted. Information necessary to service the system safely is included in the SRS and SB section of this Service Manual.

WARNING:

- **To avoid rendering the SRS inoperative, which could increase the risk of personal injury or death in the event of a collision which would result in air bag inflation, all maintenance must be performed by an authorized NISSAN/INFINITI dealer.**
- **Improper maintenance, including incorrect removal and installation of the SRS, can lead to personal injury caused by unintentional activation of the system. For removal of Spiral Cable and Air Bag Module, see the SRS section.**
- **Do not use electrical test equipment on any circuit related to the SRS unless instructed to in this Service Manual. SRS wiring harnesses can be identified by yellow and/or orange harnesses or harness connectors.**

HEADLAMP (FOR USA)

HEADLAMP (FOR USA)

PFP:26010

Component Parts and Harness Connector Location

EKS00JMB

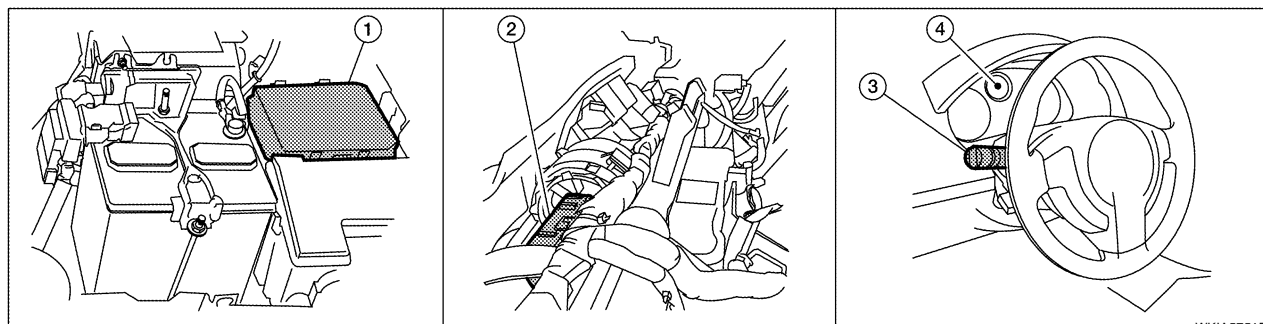

1. IPDM E/R E46, E47 and E48
2. BCM M18 and M20 (view with instrument panel removed)
3. Combination switch (lighting switch) M28
4. Combination meter M24

System Description

EKS00JMC

Headlamp operation is controlled by the BCM (body control module) based on inputs from the combination switch (lighting switch). When the lighting switch is placed in the 2ND position, the BCM receives an input signal requesting the headlamps (and tail lamps) illuminate. The BCM sends a signal, via the CAN communication lines, to the IPDM E/R (intelligent power distribution module engine room) requesting the headlamps be turned ON. The CPU (central processing unit) located in the IPDM E/R controls ground for the headlamp high and headlamp low relay coils. These relays direct power to the respective headlamps, which then illuminate.

OUTLINE

Power is supplied at all times

- to headlamp high relay RH and LH (located in IPDM E/R),
- to headlamp low relay (located in IPDM E/R),
- to ignition relay (located in IPDM E/R),
- through 15A fuse (No. 52, located in IPDM E/R) and
- through 20A fuse (No. 53, located in IPDM E/R)
- to CPU located in IPDM E/R,
- through 50A fusible link (letter j , located in fuse and fusible link block)
- to BCM terminal 70,
- through 10A fuse [No. 21, located in fuse block (J/B)]
- to BCM terminal 57, and
- through 10A fuse [No. 19, located in fuse block (J/B)]
- to combination meter terminal 1.

With the ignition switch in the ON or START position, power is supplied

- to the ignition relay (located in IPDM E/R),
- through 10A fuse [No. 12, located in fuse block (J/B)]
- to BCM terminal 38,
- through 10A fuse [No. 14, located in fuse block (J/B)]
- to combination meter terminal 2.

With the ignition switch in the ACC or ON position, power is supplied

- through 10A fuse [No. 6, located in fuse block (J/B)]
- to BCM terminal 11.

Ground is supplied

- to BCM terminal 67
- to combination meter terminals 3 and 21
- through grounds M57 and M61, and

HEADLAMP (FOR USA)

- to IPDM E/R terminals 39 and 59
- through grounds E9, E15 (all models) and E24 (with MR20DE).

HEADLAMP OPERATION

Low Beam Operation

With the lighting switch in 2ND position, the BCM receives an input signal requesting the headlamps to illuminate. The BCM then sends a signal, via the CAN communication lines, to the IPDM E/R requesting the low beam headlamps be turned ON. The CPU located in the IPDM E/R controls ground to the headlamp low relay coil, which when energized, directs power

- through 15A fuse (No. 41, located in IPDM E/R)
- through IPDM E/R terminal 54
- to headlamp RH terminal 3, and
- through 15A fuse (No. 40, located in IPDM E/R)
- through IPDM E/R terminal 52
- to headlamp LH terminal 3.

Ground is supplied

- to headlamp RH and LH terminals 5
- through grounds E9, E15 (all models) and E24 (with MR20DE).

With power and ground supplied, low beam headlamps illuminate.

High Beam Operation/Flash-to-Pass Operation

With the lighting switch in 2ND position and high beam switch in the HIGH position, the BCM receives an input signal requesting the headlamp high beams to illuminate. The flash to pass feature can be used any time and also sends a signal to the BCM. This input signal is then communicated to the IPDM E/R and the combination meter via the CAN communication lines. The CPU located in the IPDM E/R controls the headlamp high relays (LH and RH), which when energized, directs power

- through 10A fuse (No. 34, located in IPDM E/R)
- through IPDM E/R terminal 56
- to headlamp RH terminal 6, and
- through 10A fuse (No. 35, located in IPDM E/R)
- through IPDM E/R terminal 55
- to headlamp LH terminal 6.

Ground is supplied

- to headlamp RH and LH terminal 5
- through grounds E9, E15 (all models) and E24 (with MR20DE).

With power and ground supplied, the high beam headlamps illuminate.

The BCM sends a signal, via the CAN communication lines, to the combination meter requesting the high beam indicator lamp be turned ON.

COMBINATION SWITCH READING FUNCTION

Refer to [LT-65, "Combination Switch Reading Function"](#) .

CAN COMMUNICATION SYSTEM DESCRIPTION

Refer to [LAN-4, "SYSTEM DESCRIPTION"](#) .

EKS00JMD

HEADLAMP (FOR USA)

Schematic

EKS00JME

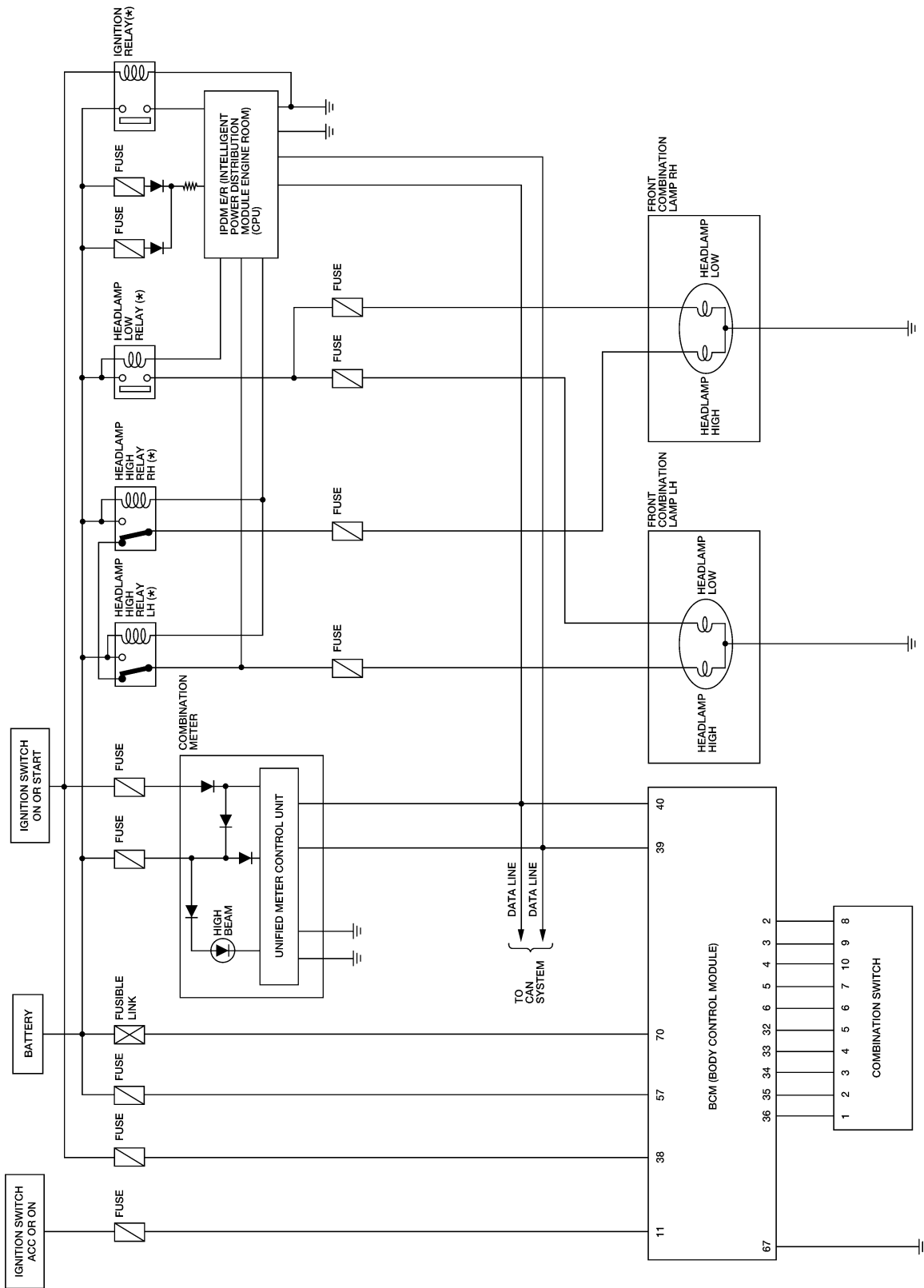

* : THIS RELAY IS BUILT INTO THE IPDM E/R (INTELLIGENT POWER DISTRIBUTION MODULE ENGINE ROOM)

A
B
C
D
E
F
G
H
I
J
LT
L
M

HEADLAMP (FOR USA)

EKS00JMF

Wiring Diagram

LT-H/LAMP-01

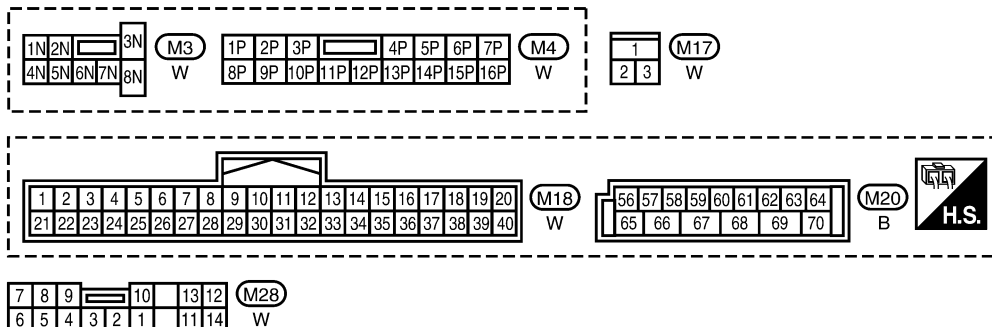
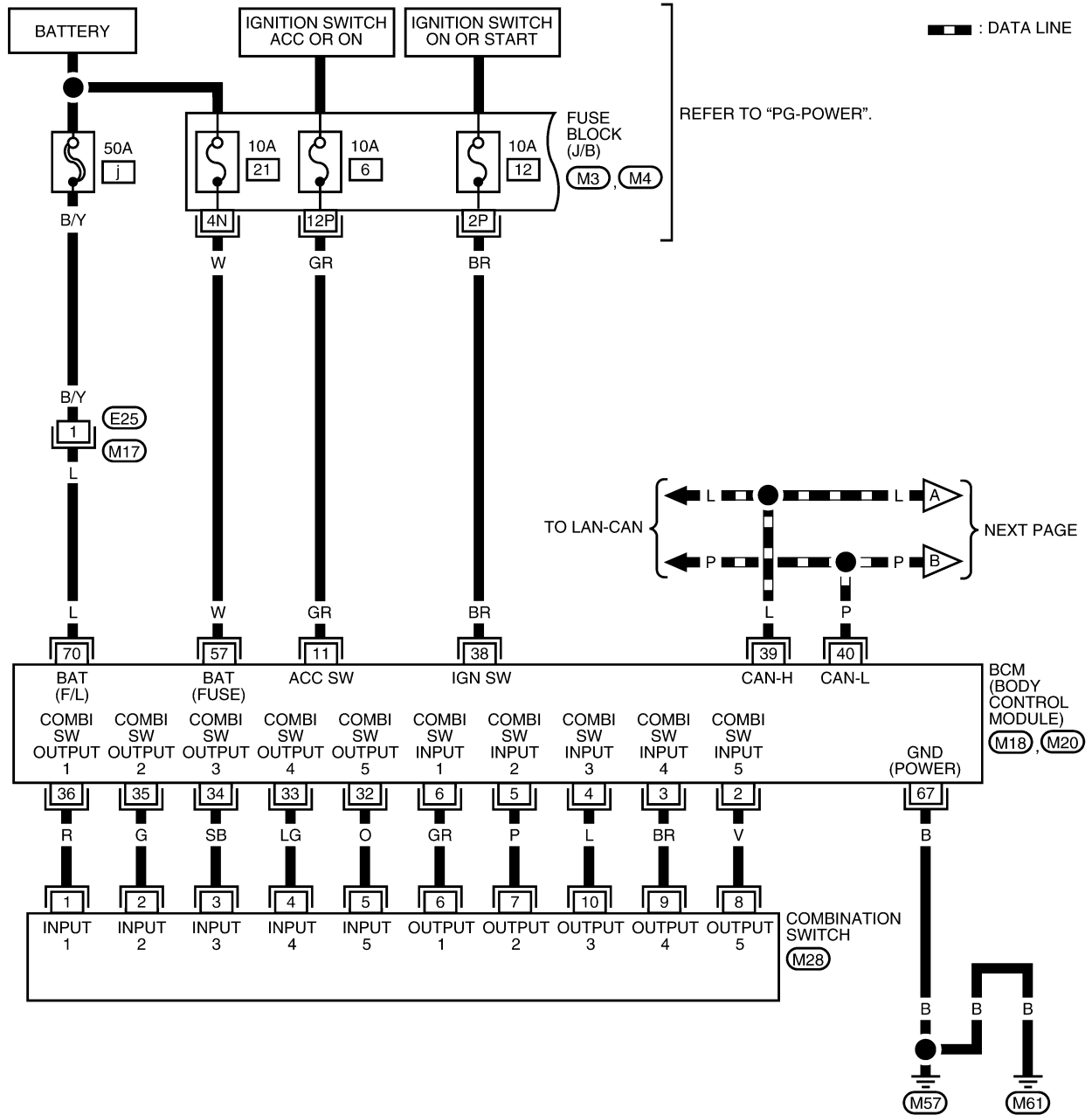

BKWA0780E

HEADLAMP (FOR USA)

LT-H/LAMP-04

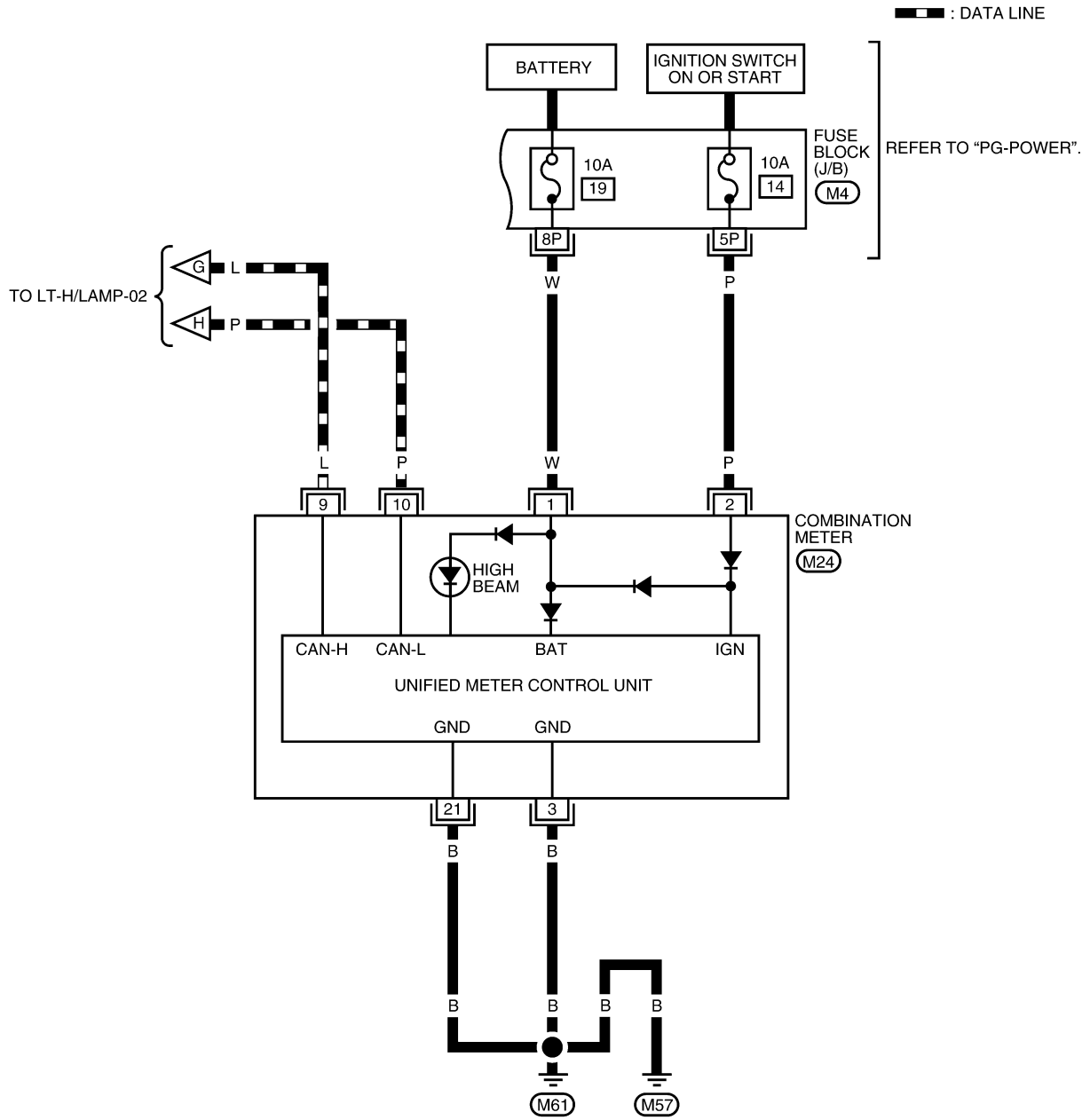

1P	2P	3P	4P	5P	6P	7P	M4	20	19	18	17	16	15	14	13	12	11	10	9	8	7	6	5	4	3	2	1	M24		
8P	9P	10P	11P	12P	13P	14P	15P	16P	W	40	39	38	37	36	35	34	33	32	31	30	29	28	27	26	25	24	23	22	21	W

BKWA0783E

HEADLAMP (FOR USA)

Terminals and Reference Values for BCM

EKS00JMG

Refer to [BCS-13, "Terminals and Reference Values for BCM"](#) .

Terminals and Reference Values for IPDM E/R

EKS00JMH

Refer to [PG-26, "Terminals and Reference Values for IPDM E/R"](#) .

How to Perform Trouble Diagnoses

EKS00JMI

1. Confirm the symptom or customer complaint.
2. Understand operation, description and function description. Refer to [LT-5, "System Description"](#) .
3. Perform the Preliminary Check. Refer to [LT-12, "Preliminary Check"](#) .
4. Check symptom and repair or replace the cause of the malfunction.
5. Do the headlamps operate normally? If YES, GO TO 6. If NO, GO TO 4.
6. Inspection end.

Preliminary Check

EKS00JMJ

CHECK POWER SUPPLY AND GROUND CIRCUIT FOR BCM

Refer to [BCS-16, "BCM Power Supply and Ground Circuit Check"](#) .

CHECK POWER SUPPLY AND GROUND CIRCUIT FOR IPDM E/R

Refer to [PG-29, "IPDM E/R Power/Ground Circuit Inspection"](#) .

CONSULT-III Function (BCM)

EKS00JMK

CONSULT-III can display each diagnostic item using the diagnostic test modes shown following.

BCM diagnostic test item	Diagnostic mode	Description
Inspection by part	WORK SUPPORT	Supports inspections and adjustments. Commands are transmitted to the BCM for setting the status suitable for required operation, input/output signals are received from the BCM and received data is displayed.
	DATA MONITOR	Displays BCM input/output data in real time.
	ACTIVE TEST	Operation of electrical loads can be checked by sending drive signal to them.
	SELF-DIAG RESULTS	Displays BCM self-diagnosis results.
	CAN DIAG SUPPORT MNTR	The result of transmit/receive diagnosis of CAN communication can be read.
	ECU PART NUMBER	BCM part number can be read.
	CONFIGURATION	Performs BCM configuration read/write functions.

WORK SUPPORT

Display Item List

Item	Description	CONSULT-III	Factory setting
BATTERY SAVER SET	Exterior lamp battery saver control mode can be changed in this mode. Selects exterior lamp battery saver control mode between ON/OFF.	ON	×
		OFF	—

DATA MONITOR

Display Item List

Monitor item	Contents
IGN ON SW "ON/OFF"	Displays "IGN position (ON)/OFF, ACC position (OFF)" judged from the ignition switch signal.
ACC ON SW "ON/OFF"	Displays "ACC (ON)/OFF, Ignition OFF (OFF)" status judged from ignition switch signal.
HI BEAM SW "ON/OFF"	Displays status (high beam switch: ON/Others: OFF) of high beam switch judged from lighting switch signal.
HEAD LAMP SW 1 "ON/OFF"	Displays status (headlamp switch 1: ON/Others: OFF) of headlamp switch 2 judged from lighting switch signal.
HEAD LAMP SW 2 "ON/OFF"	Displays status (headlamp switch 2: ON/Others: OFF) of headlamp switch 2 judged from lighting switch signal.

HEADLAMP (FOR USA)

Monitor item	Contents
LIGHT SW 1ST "ON/OFF"	Displays status (lighting switch 1st position: ON/Others: OFF) of lighting switch judged from lighting switch signal.
PASSING SW "ON/OFF"	Displays status (flash-to-pass switch: ON/Others: OFF) of flash-to-pass switch judged from lighting switch signal.
FR FOG SW "ON/OFF"	Displays status (front fog lamp switch: ON/Others: OFF) of front fog lamp switch judged from lighting switch signal.
DOOR SW - DR "ON/OFF"	Displays status of the front door LH as judged from the front door switch LH signal. (Door is open: ON/Door is closed: OFF)
DOOR SW - AS "ON/OFF"	Displays status of the front door RH as judged from the front door switch RH signal. (Door is open: ON/Door is closed: OFF)
DOOR SW - RR "ON/OFF"	Displays status of the rear door as judged from the rear door switch (RH) signal. (Door is open: ON/Door is closed: OFF)
DOOR SW - RL "ON/OFF"	Displays status of the rear door as judged from the rear door switch (LH) signal. (Door is open: ON/Door is closed: OFF)
TURN SIGNAL R "ON/OFF"	Displays status (Turn right: ON/Others: OFF) as judged from lighting switch signal.
TURN SIGNAL L "ON/OFF"	Displays status (Turn left: ON/Others: OFF) as judged from lighting switch signal.
ENGINE RUN ^{Note 1} "ON/OFF"	Displays status (Engine running: ON/Others: OFF) as judged from engine status signal.
PKB SW ^{Note 1} "ON/OFF"	Displays status (Parking brake switch: ON/Others: OFF) as judged from parking brake switch signal.

Note 1: Vehicles without daytime light system may display this item, but cannot monitor it.

ACTIVE TEST

Display Item List

Test item	Description
TAIL LAMP	Allows tail lamp relay to operate by switching ON-OFF.
HEAD LAMP	Allows headlamp relay (HI, LO) to operate by switching ON-OFF.
FR FOG LAMP	Allows fog lamp relay to operate by switching ON-OFF.

SELF-DIAGNOSTIC RESULTS

Display Item List

Monitored item	CONSULT-III display	Description
CAN communication	CAN communication [U1000]	Malfunction is detected in CAN communication.
CAN communication system	CAN communication system 1 to 6 [U1000]	Malfunction is detected in CAN system.

CONSULT-III Function (IPDM E/R)

EKS00JML

CONSULT-III can display each diagnostic item using the diagnostic test modes shown following.

IPDM E/R diagnostic Mode	Description
SELF-DIAG RESULTS	Displays IPDM E/R self-diagnosis results.
DATA MONITOR	Displays IPDM E/R input/output data in real time.
CAN DIAG SUPPORT MNTR	The result of transmit/receive diagnosis of CAN communication can be read.
ACTIVE TEST	Operation of electrical loads can be checked by sending drive signal to them.

HEADLAMP (FOR USA)

DATA MONITOR

All Signals, Main Signals, Selection from Menu

Item name	CONSULT-III screen display	Display or unit	Monitor item selection			Description
			ALL SIGNALS	MAIN SIGNALS	SELECTION FROM MENU	
Parking, license plate and tail lamps request	TAIL&CLR REQ	ON/OFF	×	×	×	Signal status input from BCM
Headlamp low beam request	HL LO REQ	ON/OFF	×	×	×	Signal status input from BCM
Headlamp high beam request	HL HI REQ	ON/OFF	×	×	×	Signal status input from BCM
Front fog lamps request	FR FOG REQ	ON/OFF	×	×	×	Signal status input from BCM
Daytime light request	DTRL REQ	ON/OFF	x	x	x	Signal status input from BCM

NOTE:

Perform monitoring of IPDM E/R data with the ignition switch ON. When the ignition switch is at ACC, the display may not be correct.

ACTIVE TEST

Test item	CONSULT-III screen display	Description
Tail lamp relay output	TAIL LAMP	Allows tail lamp relay to operate by switching operation ON-OFF at your option.
Headlamp relay (HI, LO) output	LAMPS	Allows headlamp relay (HI, LO) to operate by switching operation (OFF, HI, LO) at your option (Head lamp high beam repeats ON-OFF every 1 second).
Front fog lamp relay (FOG) output		Allows fog lamp relay (FOG) to operate by switching operation ON-OFF at your option.

Headlamp High Beam Does Not Illuminate (Both Sides)

EKS00JMM

1. CHECK COMBINATION SWITCH INPUT SIGNAL

 With CONSULT-III

1. Select "BCM" on CONSULT-III. Select "HEAD LAMP" on "SELECT TEST ITEM" screen.
2. Select "DATA MONITOR". Make sure that "HI BEAM SW" turns ON-OFF linked with operation of lighting switch.

When lighting switch is high : HI BEAM SW ON position

 Without CONSULT-III

Refer to [LT-65, "Combination Switch Inspection"](#) .

OK or NG

OK >> GO TO 2.

NG >> Check combination switch (lighting switch). Refer to [LT-65, "Combination Switch Inspection"](#) .

HEADLAMP (FOR USA)

2. HEADLAMP ACTIVE TEST

④ With CONSULT-III

1. Select "IPDM E/R" on CONSULT-III. Select "ACTIVE TEST".
2. Select "LAMPS" on "SELECT TEST ITEM" screen.
3. Touch "HI" screen.
4. Make sure headlamp high beam operates.

**Headlamp high beam should operate
(Headlamp high beam repeats ON-OFF every 2 seconds).**

⊗ Without CONSULT-III

1. Start auto active test. Refer to [PG-22, "Auto Active Test"](#) .
2. Make sure headlamp high beam operates.

Headlamp high beam should operate.

OK or NG

- OK >> GO TO 3.
NG >> GO TO 4.

3. CHECK IPDM E/R

1. Select "IPDM E/R" on CONSULT-III. Select "DATA MONITOR".
2. Make sure "HL HI REQ" turns ON when lighting switch is in high position.

**When lighting switch is high : HL HI REQ ON
position**

OK or NG

- OK >> Replace IPDM E/R. Refer to [PG-30, "Removal and Installation of IPDM E/R"](#) .
NG >> Replace BCM. Refer to [BCS-21, "Removal and Installation of BCM"](#) .

4. HEADLAMP HIGH BEAM FUSE INSPECTION

Inspect 10A fuse [No. 34 (RH) and No. 35 (LH), located in the IPDM E/R].

OK or NG

- OK >> GO TO 5.
NG >> Repair harness.

5. BULB INSPECTION

Inspect inoperative headlamp bulbs.

OK or NG

- OK >> GO TO 6.
NG >> Replace headlamp bulb. Refer to [LT-25, "HEADLAMP \(HIGH/LOW\)"](#) .

A
B
C
D
E
F
G
H
I
J
LT
L
M

HEADLAMP (FOR USA)

6. CHECK HEADLAMP INPUT SIGNAL

④ With CONSULT-III

1. Turn ignition switch OFF.
2. Disconnect headlamp connector.
3. Turn ignition switch ON.
4. Select "IPDM E/R" on CONSULT-III. Select "ACTIVE TEST".
5. Select "LAMPS" on "SELECT TEST ITEM" screen.
6. Touch "HI" screen.
7. When headlamp high beam is operating, check voltage between headlamp harness connector and ground (Headlamp high beam repeats ON-OFF every 2 seconds).

Terminal			(-)	Voltage
(+)		Terminal		
Headlamp connector				
RH	E20	6	Ground	Battery voltage
LH	E21			

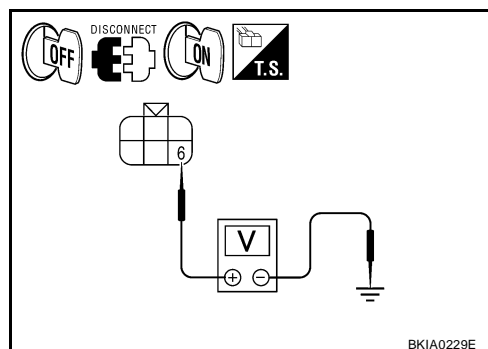

⊗ Without CONSULT-III

1. Turn ignition switch OFF.
2. Disconnect headlamp connector.
3. Turn ignition switch ON.
4. Start auto active test. Refer to [PG-22, "Auto Active Test"](#) .
5. When headlamp high beam is operating, check voltage between headlamp harness connector and ground.

Terminal			(-)	Voltage
(+)		Terminal		
Headlamp connector				
RH	E20	6	Ground	Battery voltage
LH	E21			

OK or NG

- OK >> GO TO 7.
 NG >> GO TO 8.

7. CHECK HEADLAMP GROUND CIRCUIT

1. Turn ignition switch OFF.
2. Check continuity between headlamp harness connector and ground.

Headlamp connector		Terminal	Ground	Continuity
RH	E20	5		Ground
LH	E21			

OK or NG

- OK >> Check front combination lamp connector for damage or poor connection. Repair as necessary.
 NG >> Repair harness.

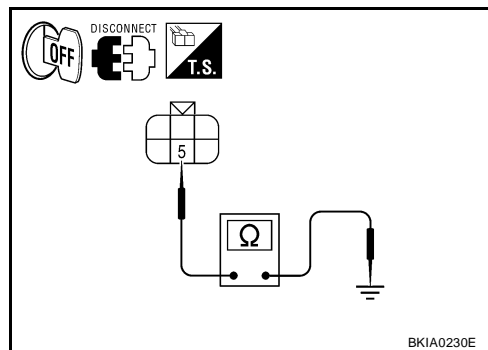

HEADLAMP (FOR USA)

8. CHECK HEADLAMP CIRCUIT

1. Turn ignition switch OFF.
2. Disconnect IPDM E/R connector.
3. Check continuity between IPDM E/R harness connector (A) and headlamp harness connector (B).

Circuit	A		B		Continuity
	Connector	Terminal	Connector	Terminal	
RH	E47	56	E20	6	Yes
LH		55	E21		

OK or NG

OK >> Replace IPDM E/R. Refer to [PG-30, "Removal and Installation of IPDM E/R"](#) .

NG >> Repair harness or connector.

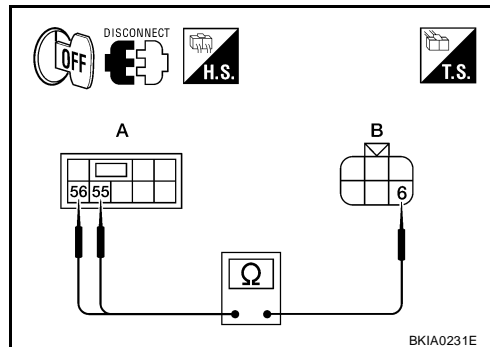

Headlamp High Beam Does Not Illuminate (One Side)

EKS00JMN

1. HEADLAMP HIGH BEAM FUSE INSPECTION

Inspect 10A fuse [No. 34 (RH) or No. 35 (LH) located in IPDM E/R].

OK or NG

OK >> GO TO 2.

NG >> Repair harness.

2. CHECK BULB

Check headlamp bulb which does not illuminate.

OK or NG

OK >> GO TO 3.

NG >> Replace bulb. Refer to [LT-25, "HEADLAMP \(HIGH/LOW\)"](#) .

3. CHECK HEADLAMP INPUT SIGNAL

1. Turn ignition switch OFF.
2. Disconnect headlamp connector.
3. Lighting switch is turned to HIGH position.
4. Check voltage between headlamp harness connector and ground.

Terminal (+)			Terminal (-)	Voltage
Headlamp connector	Terminal			
RH	E20	6	Ground	Battery voltage
LH	E21			

OK or NG

OK >> GO TO 4.

NG >> GO TO 5.

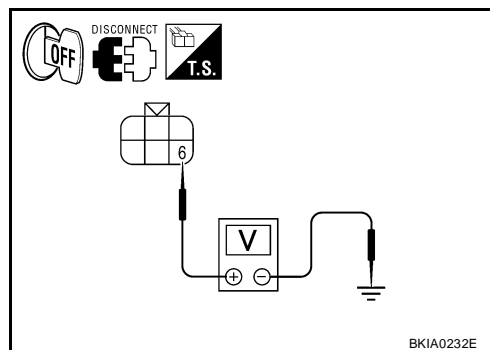

HEADLAMP (FOR USA)

4. CHECK HEADLAMP GROUND CIRCUIT

1. Turn ignition switch OFF.
2. Check continuity between headlamp harness connector and ground.

Headlamp connector		Terminal	Ground	Continuity
RH	E20	5		Ground
LH	E21			

OK or NG

- OK >> Check condition of headlamp harness connector.
 NG >> Repair harness or connector.

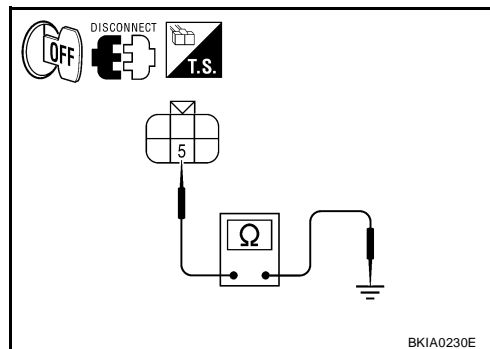

5. CHECK HEADLAMP CIRCUIT

1. Turn ignition switch OFF.
2. Disconnect IPDM E/R connector.
3. Check continuity between IPDM E/R harness connector (A) and headlamp harness connector (B).

Circuit	A		B		Continuity
	Connector	Terminal	Connector	Terminal	
RH	E47	56	E20	6	Yes
LH		55	E21		

OK or NG

- OK >> Replace IPDM E/R. Refer to [PG-30, "Removal and Installation of IPDM E/R"](#) .
 NG >> Repair harness or connector.

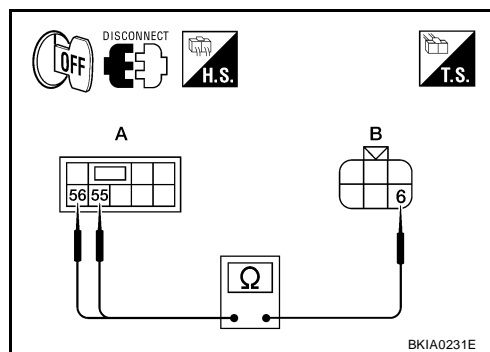

High Beam Indicator Lamp Does Not Illuminate

EKS00JMO

1. BULB INSPECTION

Inspect CAN communication system. Refer to [LAN-23, "TROUBLE DIAGNOSIS"](#) .

OK or NG

- OK >> Replace combination meter. Refer to [DI-24, "Removal and Installation"](#) .
 NG >> Repair as necessary.

Headlamp Low Beam Does Not Illuminate (Both Sides)

EKS00JMP

1. CHECK COMBINATION SWITCH INPUT SIGNAL

Ⓟ With CONSULT-III

1. Select "BCM" on CONSULT-III. Select "HEAD LAMP".
2. Select "DATA MONITOR". Make sure that "HEAD LAMP SW 1" and "HEAD LAMP SW 2" turns ON-OFF linked with operation of lighting switch.

When lighting switch is 2ND position : HEAD LAMP SW 1 ON
: HEAD LAMP SW 2 ON

ⓧ Without CONSULT-III

Refer to [LT-65, "Combination Switch Inspection"](#) .

OK or NG

- OK >> GO TO 2.
 NG >> Check combination switch (lighting switch). Refer to [LT-65, "Combination Switch Inspection"](#) .

HEADLAMP (FOR USA)

2. CHECK HEADLAMP ACTIVE TEST

With CONSULT-III

1. Select "IPDM E/R" on CONSULT-III. Select "ACTIVE TEST".
2. Select "LAMPS" on "SELECT TEST ITEM" screen.
3. Touch "LO" screen.
4. Make sure headlamp low beam operates.

Headlamp low beam should operate.

Without CONSULT-III

1. Start auto active test. Refer to [PG-22, "Auto Active Test"](#) .
2. Make sure headlamp low beam operates.

Headlamp low beam should operate.

OK or NG

- OK >> GO TO 3.
NG >> GO TO 4.

3. CHECK IPDM E/R

1. Select "IPDM E/R" on CONSULT-III. Select "DATA MONITOR".
2. Make sure "HL LO REQ" turns ON when lighting switch is in 2ND position.

When lighting switch is 2ND : HL LO REQ ON position

OK or NG

- OK >> Replace IPDM E/R. Refer to [PG-30, "Removal and Installation of IPDM E/R"](#) .
NG >> Replace BCM. Refer to [BCS-21, "Removal and Installation of BCM"](#) .

4. HEADLAMP LOW BEAM FUSE INSPECTION

Inspect 15A fuse [No. 40 (LH) and No. 41 (RH) located in IPDM E/R].

OK or NG

- OK >> GO TO 5.
NG >> Repair harness.

5. BULB INSPECTION

Inspect inoperative headlamp bulbs.

OK or NG

- OK >> GO TO 6.
NG >> Replace headlamp bulb. Refer to [LT-25, "HEADLAMP \(HIGH/LOW\)"](#) .

A
B
C
D
E
F
G
H
I
J
LT
L
M

HEADLAMP (FOR USA)

6. CHECK HEADLAMP INPUT SIGNAL

④ With CONSULT-III

1. Turn ignition switch OFF.
2. Disconnect headlamp connector.
3. Turn ignition switch ON.
4. Select "IPDM E/R" on CONSULT-III. Select "ACTIVE TEST".
5. Select "LAMPS" on "SELECT TEST ITEM" screen.
6. Touch "LO" screen.
7. When headlamp low beam is operating, check voltage between headlamp harness connector and ground.

Terminal		Terminal	(-)	Voltage
(+)				
Headlamp connector	Terminal	3	Ground	Battery voltage
RH	E20			
LH	E21			

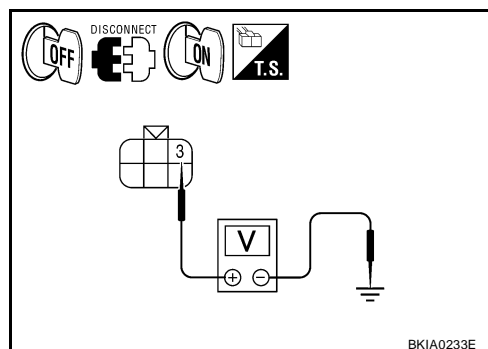

⊗ Without CONSULT-III

1. Turn ignition switch OFF.
2. Disconnect headlamp connector.
3. Turn ignition switch ON.
4. Start auto active test. Refer to [PG-22, "Auto Active Test"](#).
5. When headlamp low beam is operating, check voltage between headlamp harness connector and ground.

Terminal		Terminal	(-)	Voltage
(+)				
Headlamp connector	Terminal	3	Ground	Battery voltage
RH	E20			
LH	E21			

OK or NG

- OK >> GO TO 7.
 NG >> GO TO 8.

7. CHECK HEADLAMP GROUND CIRCUIT

1. Turn ignition switch OFF.
2. Check continuity between headlamp harness connector (B) and ground.

Headlamp connector		Terminal	Ground	Continuity
RH	E20	5		Ground
LH	E21			

OK or NG

- OK >> Check front combination lamp connector for damage or poor connection. Repair as necessary.
 NG >> Repair harness.

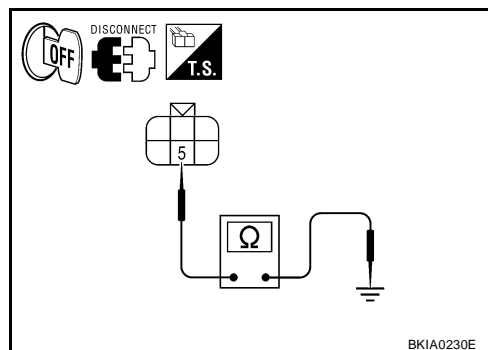

HEADLAMP (FOR USA)

8. CHECK HEADLAMP CIRCUIT

1. Turn ignition switch OFF.
2. Disconnect IPDM E/R connector.
3. Check continuity between IPDM E/R harness connector (A) and headlamp harness connector (B).

Circuit	A		B		Continuity
	Connector	Terminal	Connector	Terminal	
RH	E47	54	E20	3	Yes
LH		52	E21		

OK or NG

OK >> Replace IPDM E/R. Refer to [PG-30, "Removal and Installation of IPDM E/R"](#) .

NG >> Repair harness or connector.

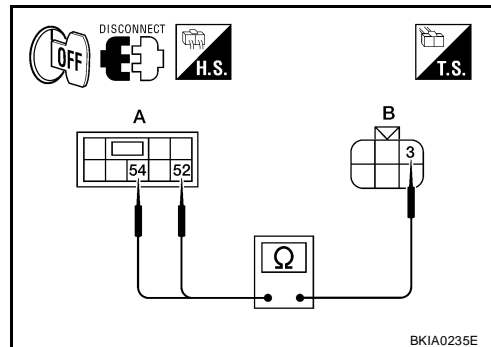

Headlamp Low Beam Does Not Illuminate (One Side)

EKS00JMQ

1. HEADLAMP LOW BEAM FUSE INSPECTION

Inspect 15A fuse [No. 40 (LH) and No. 41 (RH) located in IPDM E/R].

OK or NG

OK >> GO TO 2.

NG >> Repair harness.

2. CHECK BULB

Check bulb of headlamp which does not illuminate.

OK or NG

OK >> GO TO 3.

NG >> Replace bulb. Refer to [LT-25, "HEADLAMP \(HIGH/LOW\)"](#) .

3. CHECK HEADLAMP INPUT SIGNAL

1. Turn ignition switch OFF.
2. Disconnect headlamp connector.
3. Lighting switch is turned to 2ND position.
4. Check voltage between headlamp harness connector and ground.

Terminal (+)			Terminal (-)	Voltage
Headlamp connector	Terminal			
RH	E20	3	Ground	Battery voltage
LH	E21			

OK or NG

OK >> GO TO 4.

NG >> GO TO 5.

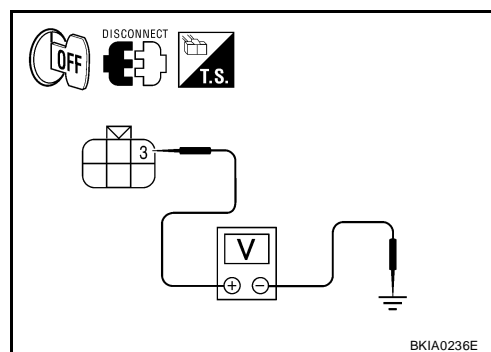

HEADLAMP (FOR USA)

4. CHECK HEADLAMP GROUND CIRCUIT

1. Turn ignition switch OFF.
2. Check continuity between headlamp harness connector and ground.

Headlamp connector		Terminal	Ground	Continuity
RH	E20	5		Yes
LH	E21			

OK or NG

- OK >> Check condition of headlamp harness connector.
 NG >> Repair harness or connector.

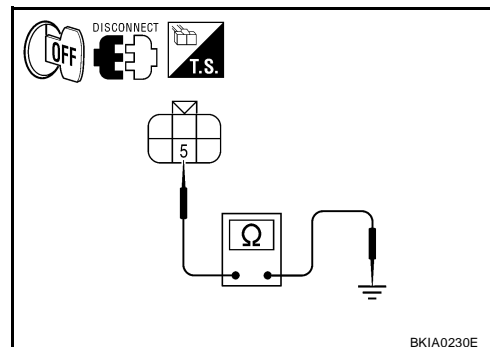

5. CHECK HEADLAMP CIRCUIT

1. Turn ignition switch OFF.
2. Disconnect IPDM E/R connector.
3. Check continuity between IPDM E/R harness connector (A) and headlamp harness connector (B).

Circuit	A		B		Continuity
	Connector	Terminal	Connector	Terminal	
RH	E47	54	E20	3	Yes
LH		52	E21		

OK or NG

- OK >> Replace IPDM E/R. Refer to [PG-30, "Removal and Installation of IPDM E/R"](#) .
 NG >> Repair harness or connector.

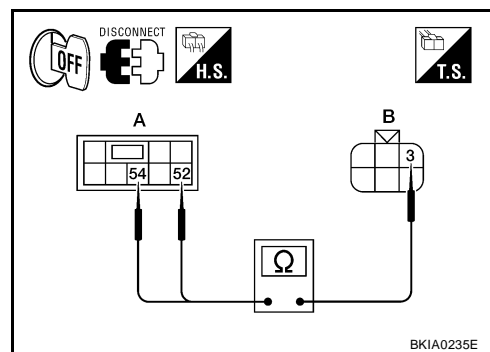

Headlamps Do Not Turn OFF

EKS00JMR

1. CHECK HEADLAMPS TURN OFF

Make sure that lighting switch is OFF. Make sure headlamp turns OFF when ignition switch is turned OFF.

OK or NG

- OK >> GO TO 3.
 NG >> GO TO 2.

2. CHECK COMBINATION SWITCH INPUT SIGNAL

1. Select "BCM" on CONSULT-III. Select "HEAD LAMP" on "SELECT TEST ITEM" screen.
2. Select "DATA MONITOR". Make sure that "HEAD LAMP SW 1" and "HEAD LAMP SW 2" turns ON-OFF linked with operation of lighting switch.

When lighting switch is OFF : HEAD LAMP SW 1 OFF position : HEAD LAMP SW 2 OFF

OK or NG

- OK >> Replace IPDM E/R. Refer to [PG-30, "Removal and Installation of IPDM E/R"](#) .
 NG >> Check combination switch (lighting switch). Refer to [LT-65, "Combination Switch Inspection"](#) .

3. CHECKING CAN COMMUNICATIONS BETWEEN BCM AND IPDM E/R

Select "BCM" on CONSULT-III, and perform self-diagnosis for "BCM".

Display of self-diagnosis results

- NO DTC>> Replace IPDM E/R. Refer to [PG-30, "Removal and Installation of IPDM E/R"](#) .
 CAN COMM CIRCUIT>> Refer to [LAN-23, "TROUBLE DIAGNOSIS"](#) .

HEADLAMP (FOR USA)

Aiming Adjustment

EKS00JMS

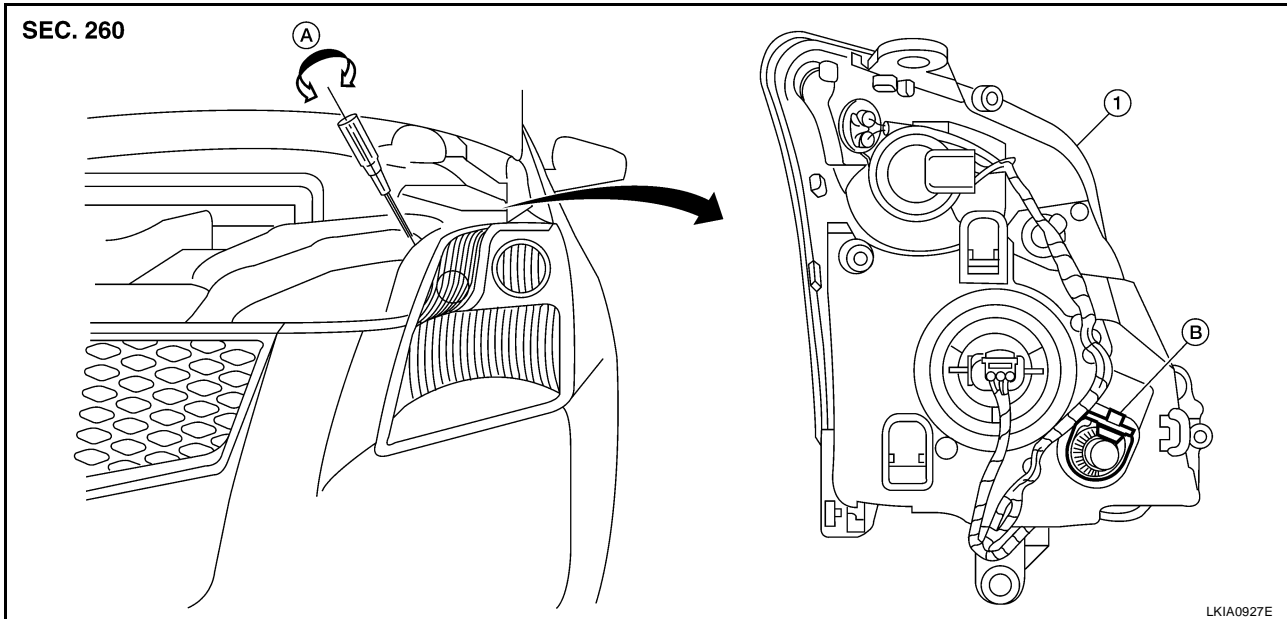

1. Headlamp

A. Inner and outer adjustment

B. Adjusting screw

PREPARATION BEFORE ADJUSTING

Before performing aiming adjustment, check the following.

1. Keep all tires inflated to correct pressures.
2. Place vehicle on level surface.
3. Set that there is no-load in vehicle other than the driver (or equivalent weight placed in driver's position).
Coolant, engine oil filled up to correct level and full fuel tank, spare tire, jack and tools are in place.

LOW BEAM AND HIGH BEAM

1. Turn headlamp low beam ON.
2. Use adjusting screw to perform aiming adjustment.

A

B

C

D

E

F

G

H

I

J

LT

L

M

HEADLAMP (FOR USA)

ADJUSTMENT USING AN ADJUSTMENT SCREEN (LIGHT/DARK BORDERLINE)

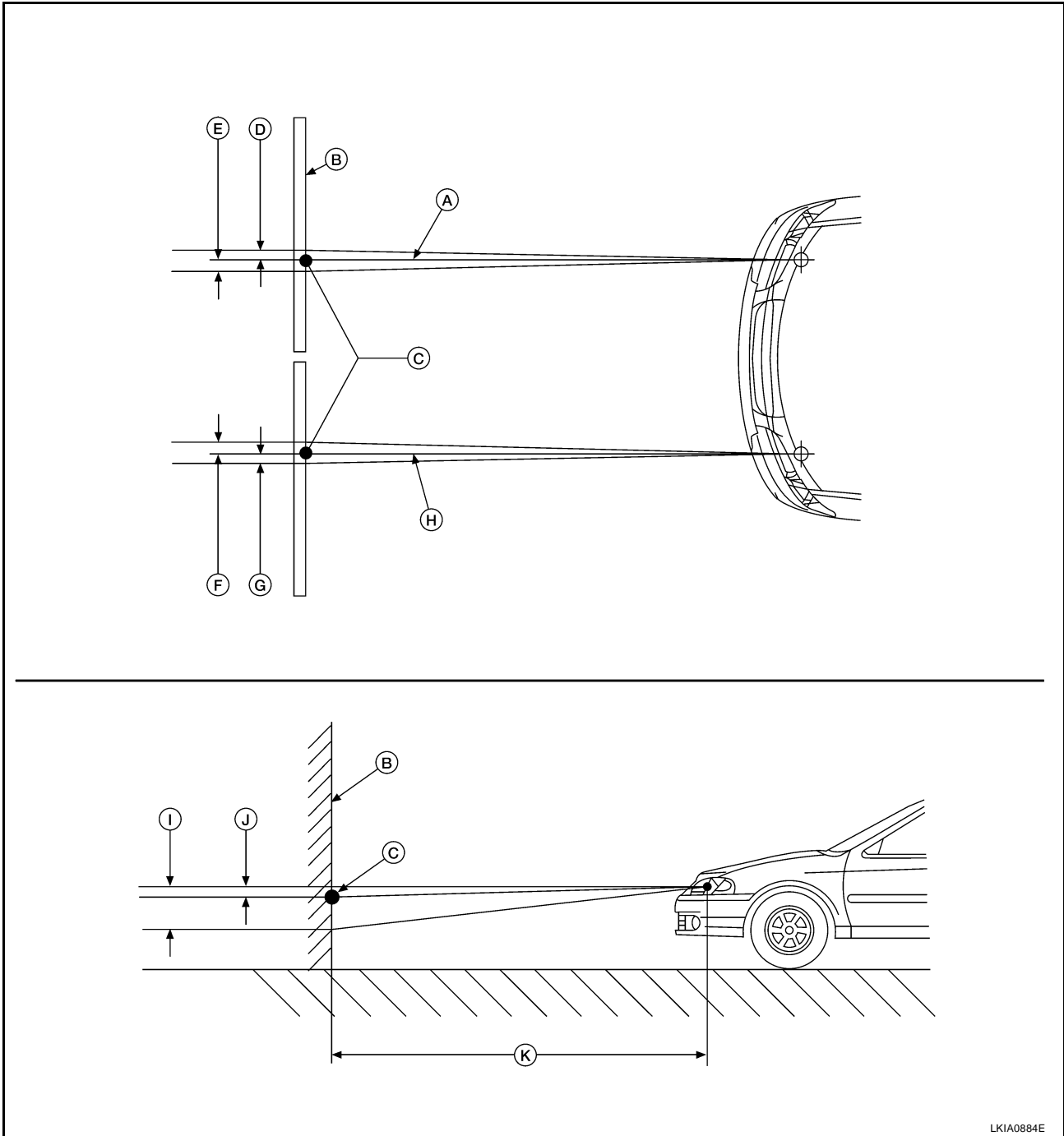

LKIA0884E

A.	Headlamp beam (RH)	B.	Vertical center line of headlamp	C.	Horizontal/Vertical center point of headlamp
D.	66.5 mm (2.6 in)	E.	66.5 mm (2.6 in)	F.	66.5 mm (2.6 in)
G.	66.5 mm (2.6 in)	H.	Headlamp beam (LH)	I.	53.2 mm (2.1 in)
J.	13.3 mm (0.5 in)	K.	7.62 m (25 ft)		

- Aim each headlamp individually and ensure other headlamp beam pattern is blocked from screen.
 - For horizontal headlamp aiming, adjust headlamp until beam pattern is at horizontal center point.
 - For vertical headlamp aiming, adjust headlamp until beam pattern is positioned per specified dimensions.

HEADLAMP (FOR USA)

EKS00JMT

Bulb Replacement HEADLAMP (HIGH/LOW)

1. Turn lighting switch OFF.
2. Turn the headlamp (high/low) bulb socket counterclockwise and remove.
3. Remove the headlamp (high/low) bulb.
4. Installation is in the reverse order of removal.

HEADLAMP (HIGH/LOW) SE-R

1. Turn lighting switch OFF.
2. Remove the resonator. Refer to [EM-18, "AIR CLEANER AND AIR DUCT"](#) .
3. Turn the headlamp (high/low) bulb socket counterclockwise and remove.
4. Remove the headlamp (high/low) bulb.
5. Installation is in the reverse order of removal.

PARKING (CLEARANCE) LAMP

1. Turn lighting switch OFF.
2. Turn the parking (clearance) lamp socket counterclockwise and remove.
3. Remove the parking (clearance) lamp bulb.
4. Installation is in the reverse order of removal.

FRONT TURN SIGNAL LAMP

1. Turn lighting switch OFF.
2. Turn the front turn signal lamp socket counterclockwise and remove.
3. Remove the front turn signal lamp bulb.
4. Installation is in the reverse order of removal.

FRONT SIDE MARKER LAMP

1. Turn lighting switch OFF.
2. Turn the front side marker lamp socket counterclockwise and remove.
3. Remove the front side marker lamp bulb.
4. Installation is in the reverse order of removal.

Removal and Installation REMOVAL

EKS00JMU

1. Disconnect the negative battery terminal.
2. Remove front bumper fascia. Refer to [EI-14, "FRONT BUMPER"](#) .
3. Remove the headlamp bolts (A).
4. Pull the headlamp (1) toward the vehicle front, detach the harness clip, disconnect connector, and remove the headlamp.

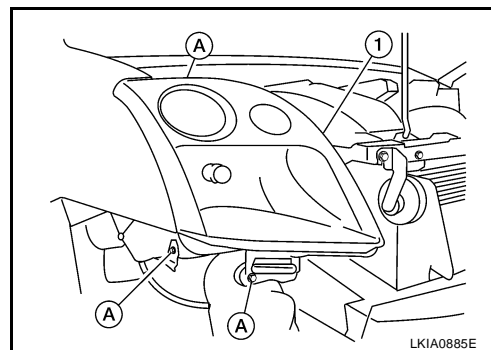

INSTALLATION

Installation is in the reverse order of removal.

- After installation, perform aiming adjustment. Refer to [LT-23, "Aiming Adjustment"](#) .

HEADLAMP (FOR USA)

Disassembly and Assembly

EKS00JMV

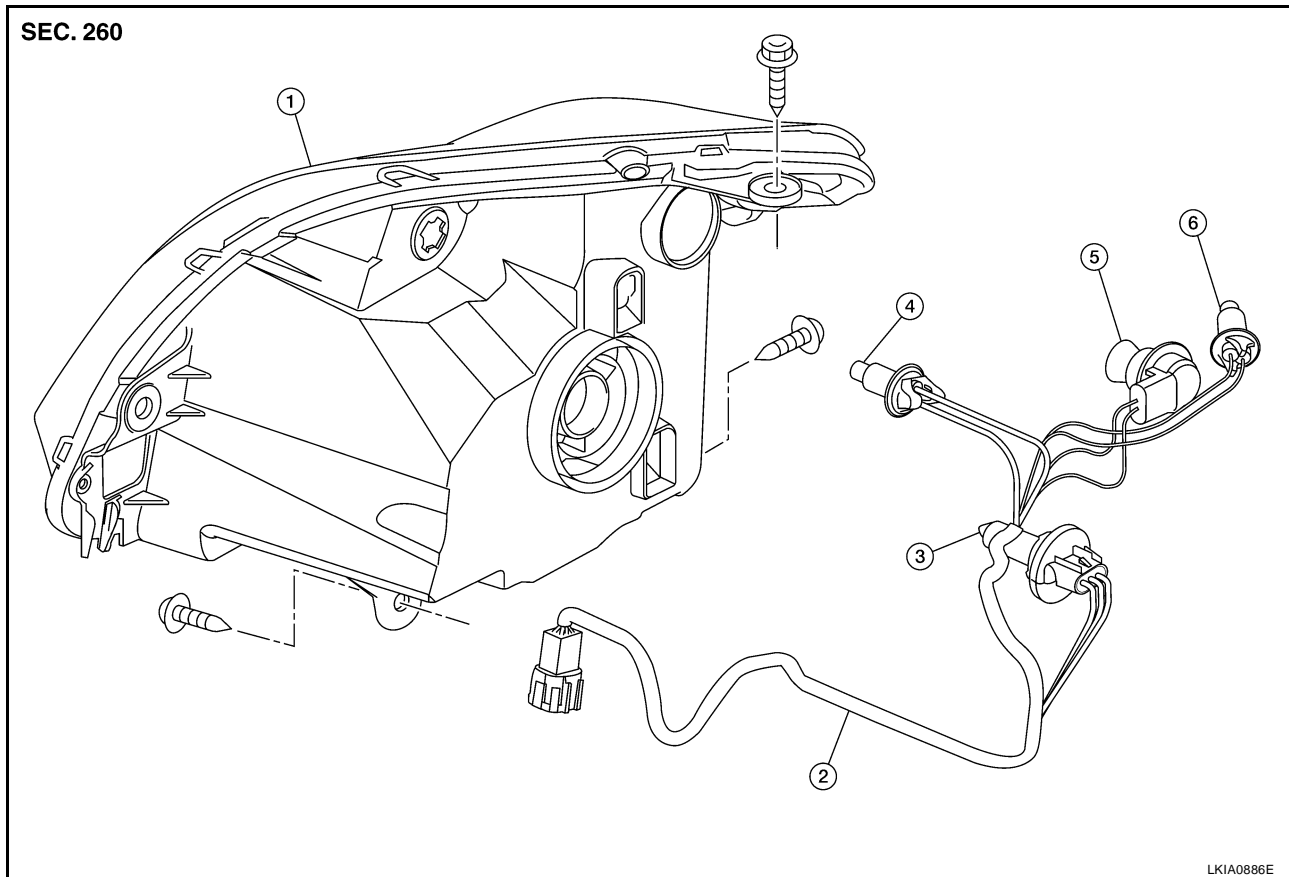

- | | | |
|---|---------------------------------------|-----------------------------------|
| 1. Headlamp housing assembly | 2. Headlamp housing assembly harness | 3. Halogen bulb (high/low) socket |
| 4. Parking (clearance) lamp bulb socket | 5. Front turn signal lamp bulb socket | 6. Side marker lamp bulb socket |

DISASSEMBLY

1. Turn the halogen (high/low) bulb socket counterclockwise and remove.
2. Turn the parking (clearance) lamp bulb socket counterclockwise and remove.
3. Turn the front turn signal lamp bulb socket counterclockwise and remove.
4. Turn side marker lamp bulb counterclockwise and remove.
5. Detach the headlamp bulb harness from the headlamp assembly.

ASSEMBLY

Assembly is in the reverse order of disassembly.

HEADLAMP (FOR CANADA) - DAYTIME LIGHT SYSTEM -

HEADLAMP (FOR CANADA) - DAYTIME LIGHT SYSTEM -

PFP:26010

Component Parts and Harness Connector Location

EKS00JMW

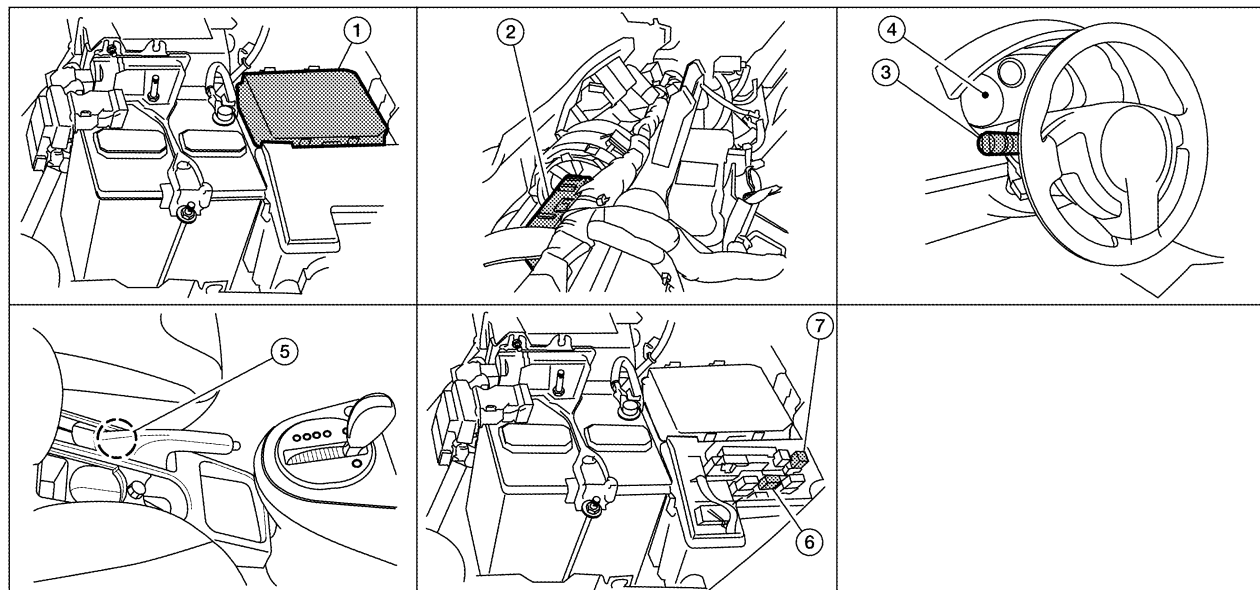

1. IPDM E/R E46, E47 and E48
2. BCM M18 and M20 (view with instrument panel removed)
3. Combination switch (lighting switch) M28
4. Combination meter M24
5. Parking brake switch B24
6. Daytime Light Relay 1
7. Daytime Light Relay 2

WKIA5752E

System Description

EKS00JMX

Headlamp operation is controlled by the BCM (body control module) based on inputs from the combination switch (lighting switch). When the lighting switch is placed in the 2ND position, the BCM receives an input signal requesting the headlamps (and tail lamps) illuminate. The request is then communicated to the IPDM E/R (intelligent power distribution module engine room) via the CAN communication lines. The CPU (central processing unit) located in the IPDM E/R controls ground for the headlamp high and headlamp low relay coils. These relays direct power to the respective headlamps, which then illuminate. When the headlamp switch is OFF or in the 1ST position (parking lamps ON), the parking brake is released and the engine is running, the IPDM E/R de-energizes the headlamp relays and supplies ground to the daytime light relay 1 to actuate the daytime light function.

OUTLINE

Power is supplied at all times

- to headlamp high relay RH and LH (located in IPDM E/R),
- to headlamp low relay (located in IPDM E/R),
- to ignition relay (located in IPDM E/R)
- through 15A fuse (No. 52, located in IPDM E/R) and
- through 20A fuse (No. 53, located in IPDM E/R)
- to CPU located in IPDM E/R,
- through 50A fusible link (letter j , located in fuse and fusible link box)
- to BCM terminal 70,
- through 10A fuse [No. 21, located in fuse block (J/B)]
- to BCM terminal 57,
- through 10A fuse [No. 19, located in fuse block (J/B)]
- to combination meter terminal 1,
- through 10A fuse (No. 27, located in fuse and fusible link box)
- to the daytime light relay 1 terminals 2 and 5.

With the ignition switch in the ON or START position, power is supplied

HEADLAMP (FOR CANADA) - DAYTIME LIGHT SYSTEM -

- to the ignition relay (located in IPDM E/R),
- through 10A fuse [No. 12, located in fuse block (J/B)]
- to BCM terminal 38,
- through 10A fuse [No. 14, located in fuse block (J/B)]
- to combination meter terminal 2.

With the ignition switch in the ACC or ON position, power is supplied

- through 10A fuse [No. 6, located in fuse block (J/B)]
- to BCM terminal 11.

Ground is supplied

- to BCM terminal 67 and
- to combination meter terminals 3 and 21
- through grounds M57 and M61,
- to IPDM E/R terminals 39 and 59
- through grounds E9, E15 (all models) and E24 (with MR20DE).

HEADLAMP OPERATION

Low Beam Operation

With the lighting switch in 2ND position, the BCM receives an input signal requesting the headlamps to illuminate. This input signal is communicated to the IPDM E/R via the CAN communication lines. The CPU located in the IPDM E/R controls the headlamp low relay coil, which when energized, directs power

- through 15A fuse (No. 41, located in IPDM E/R)
- through IPDM E/R terminal 54
- to front combination lamp RH terminal 3,
- through 15A fuse (No. 40, located in IPDM E/R)
- through IPDM E/R terminal 52
- to daytime light relay 2 terminals 1 and 3 (energizing the relay) and
- through daytime light relay 2 terminal 5
- to front combination lamp LH terminal 3.

Ground is supplied

- to front combination lamp RH terminal 5
- through grounds E9, E15 and E24,
- to headlamp LH terminal 5 via
- daytime light relay 1 terminals 3 and 4
- through grounds E9, E15 (all models) and E24 (with MR20DE).

With power and ground supplied, low beam headlamps illuminate.

High Beam/Flash-to-Pass Operation

With the lighting switch in 2ND position and high beam switch in the HIGH position, the BCM receives input signal requesting the headlamp high beams to illuminate. The flash-to-pass feature can be used any time and also sends a signal to the BCM. This input signal is communicated to the IPDM E/R and the combination meter via the CAN communication lines. The CPU located in the IPDM E/R controls the headlamp high relay coil, which when energized, directs power

- through 10A fuse (No. 34, located in IPDM E/R)
- through IPDM E/R terminal 56
- to front combination lamp RH terminal 6, and
- through 10A fuse (No. 35, located in IPDM E/R)
- through IPDM E/R terminal 55
- to front combination lamp LH terminal 6.

Ground is supplied

- to front combination lamp RH terminal 5
- through grounds E9, E15 (all models) and E24 (with MR20DE),

HEADLAMP (FOR CANADA) - DAYTIME LIGHT SYSTEM -

- to front combination lamp LH terminal 5 via
- daytime light relay 1 terminals 3 and 4
- through grounds E9, E15 (all models) and E24 (with MR20DE).

With power and ground supplied, the high beam headlamps illuminate.

The BCM sends a signal to the combination meter requesting the high beam indicator lamp to turn ON.

Daytime Light System Operation

With the lighting switch in the OFF or 1ST position (parking lamps ON), the BCM receives inputs requesting the headlights off. If the parking brake is released and the engine is running, the BCM then sends a signal, via the CAN communication lines, requesting the IPDM E/R to activate the daytime light system. The CPU located in the IPDM E/R controls the daytime light relay 1 coil, which when energized, directs power

- from daytime light relay 1 terminal 3
- to front combination lamp LH terminal 5,
- through front combination lamp LH high beam terminal 6
- to IPDM E/R terminal 55,
- through 10A fuse (No. 35, located in IPDM E/R) and
- through both de-energized headlamp high relays
- to 10A fuse (No. 34, located in IPDM E/R),
- through IPDM E/R terminal 56
- to front combination lamp RH high beam terminal 6.

Ground is supplied

- to front combination lamp RH terminal 5 and
- to daytime light relay 1 terminal 4
- through grounds E9, E15 (all models) and E24 (with MR20DE),
- to daytime light relay 1 terminal 1
- through IPDM E/R terminal 49.

With power and ground supplied, high beam headlamps illuminate at reduced intensity.

COMBINATION SWITCH READING FUNCTION

Refer to [LT-65, "Combination Switch Reading Function"](#) .

CAN Communication System Description

Refer to [LAN-4, "SYSTEM DESCRIPTION"](#) .

A

B

C

D

E

F

G

H

I

J

EKS00JMY

LT

L

M

HEADLAMP (FOR CANADA) - DAYTIME LIGHT SYSTEM -

Schematic

EKS00JMZ

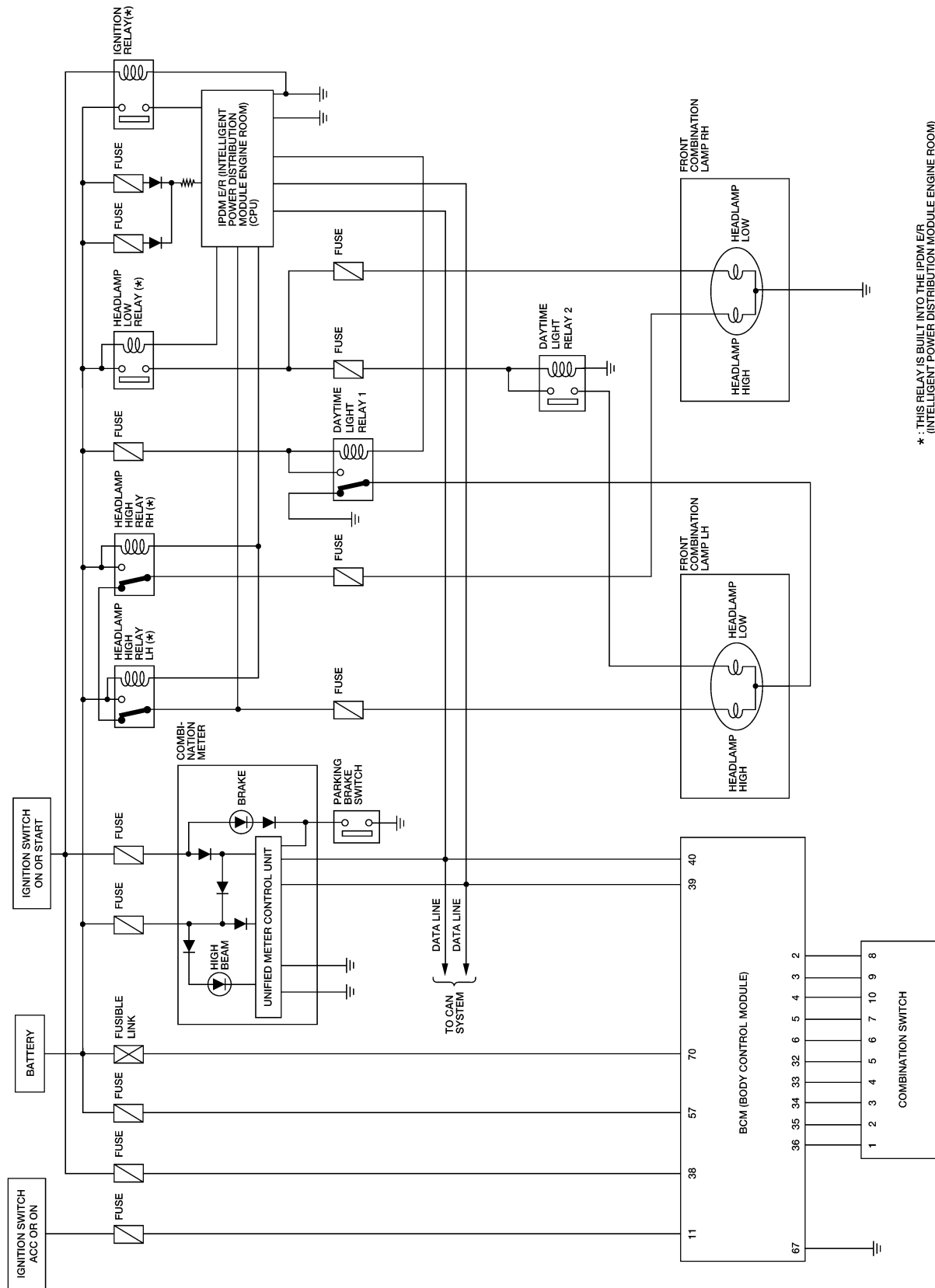

*: THIS RELAY IS BUILT INTO THE IPDM E/R (INTELLIGENT POWER DISTRIBUTION MODULE ENGINE ROOM)

BKWA0784E

HEADLAMP (FOR CANADA) - DAYTIME LIGHT SYSTEM -

Wiring Diagram — DTRL —

EKS00JN0

LT-DTRL-01

DATA LINE

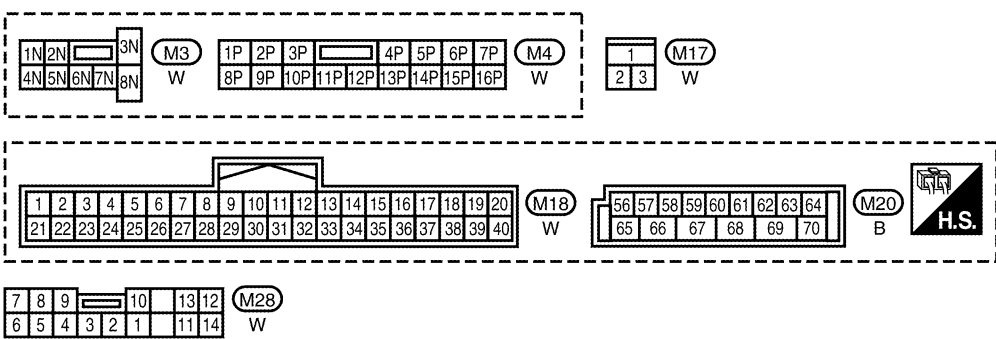
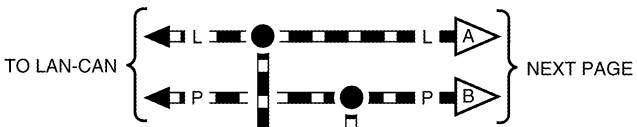
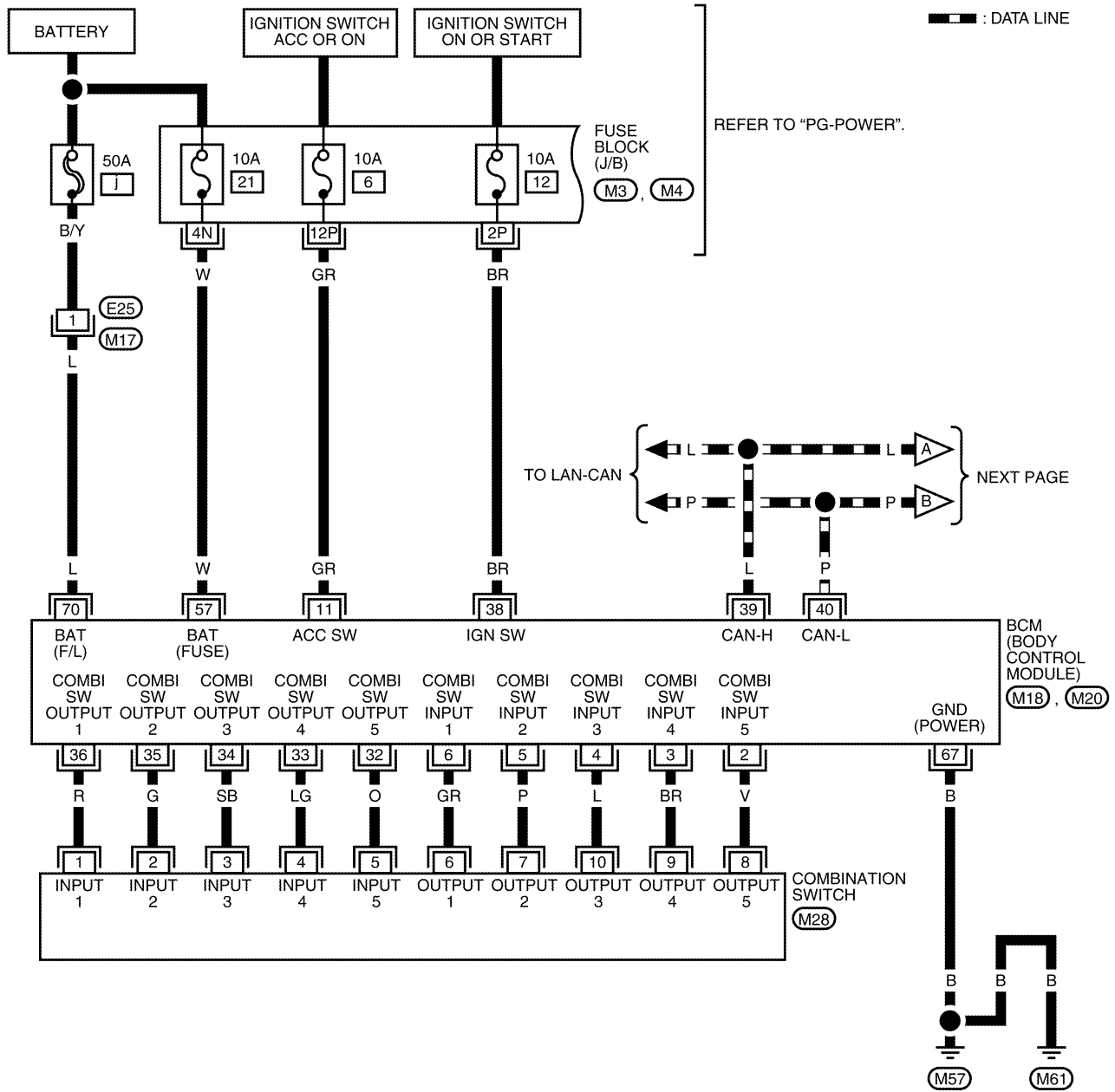

BKWA0785E

HEADLAMP (FOR CANADA) - DAYTIME LIGHT SYSTEM -

LT-DTRL-02

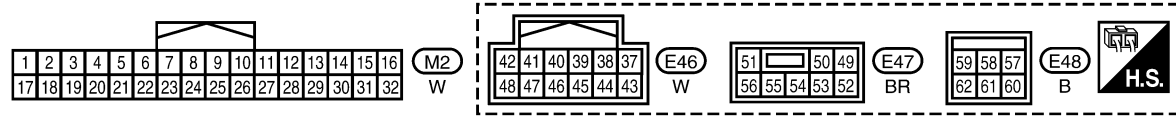
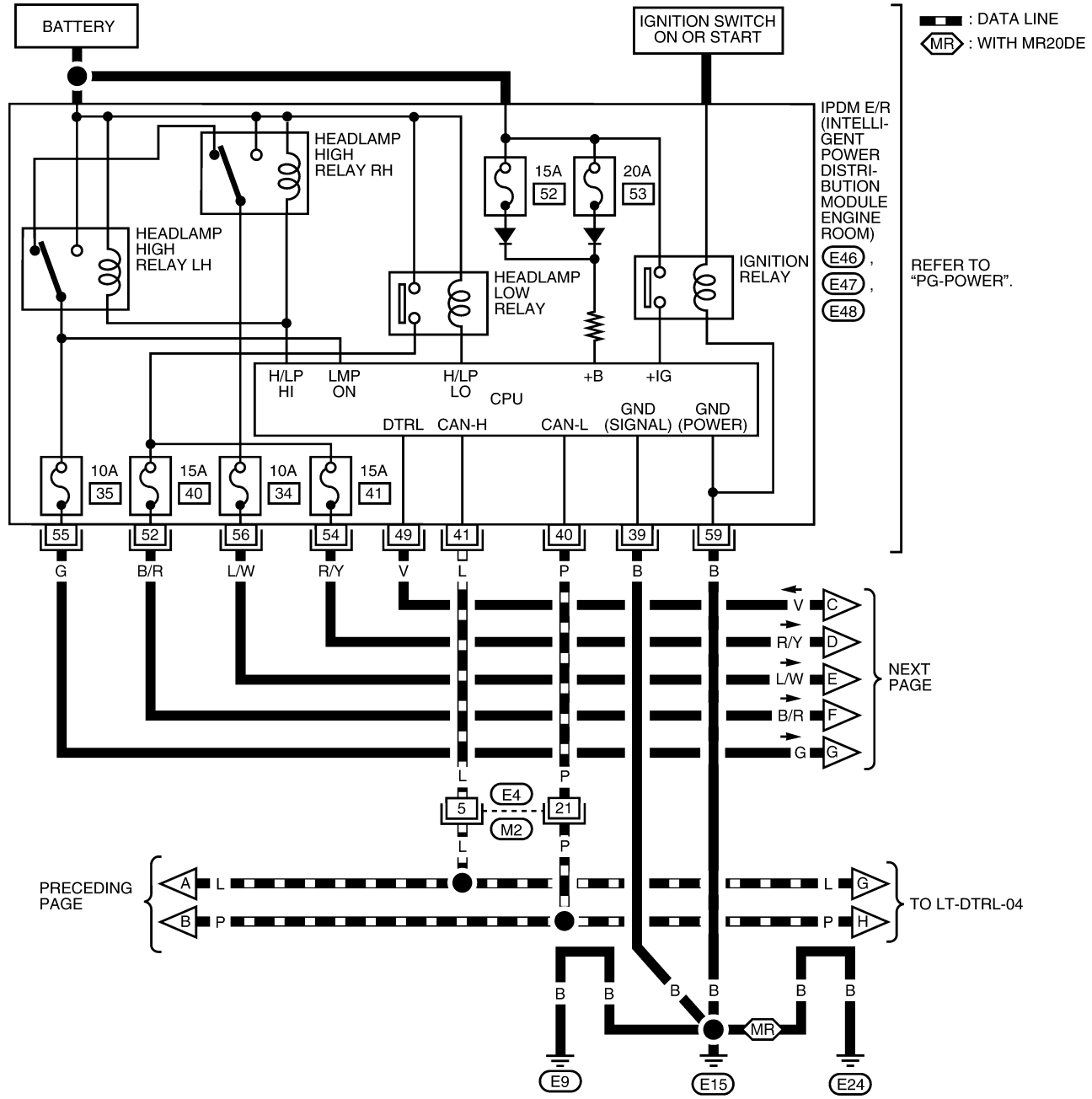

BKWA0834E

HEADLAMP (FOR CANADA) - DAYTIME LIGHT SYSTEM -

LT-DTRL-04

▬ : DATA LINE

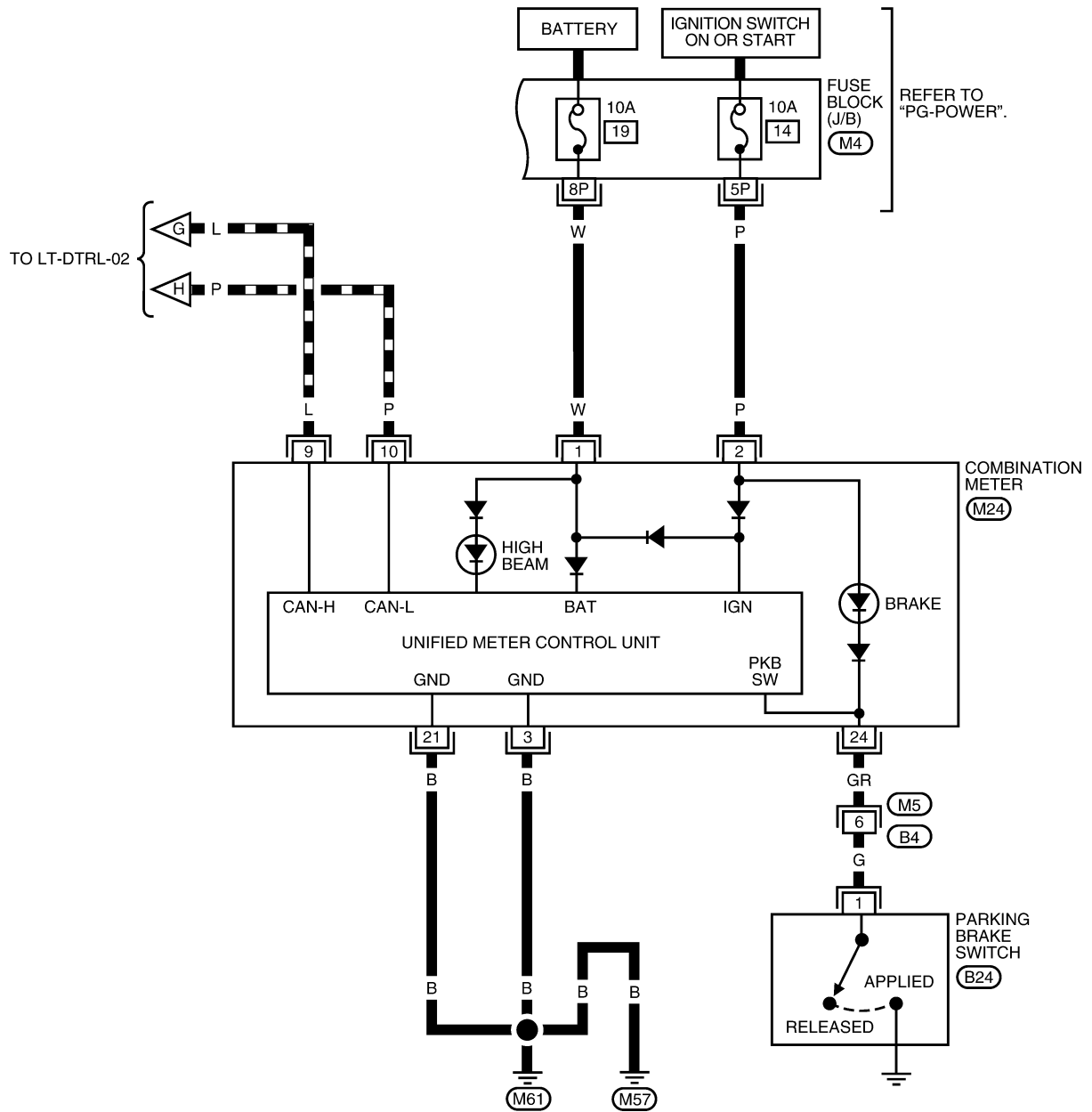

WKWA5862E

HEADLAMP (FOR CANADA) - DAYTIME LIGHT SYSTEM -

Terminals and Reference Values for BCM

EKS00JN1

Refer to [BCS-13, "Terminals and Reference Values for BCM"](#) .

A

Terminals and Reference Values for IPDM E/R

EKS00JN2

Refer to [PG-26, "Terminals and Reference Values for IPDM E/R"](#) .

B

How to Perform Trouble Diagnoses

EKS00JN3

1. Confirm the symptom or customer complaint.
2. Understand operation, description and function description. Refer to [LT-27, "System Description"](#) .
3. Perform the Preliminary Check. Refer to [LT-35, "Preliminary Check"](#) .
4. Check symptom and repair or replace the cause of the malfunction.
5. Does the daytime light system operate normally? If YES, GO TO 6. If NO, GO TO 4.
6. Inspection end.

C

D

E

Preliminary Check

EKS00JN4

CHECK BCM CONFIGURATION

1. CHECK BCM CONFIGURATION

F

Confirm BCM configuration for "DTRL" is set to "WITH". Refer to [BCS-20, "Configuration"](#) .

OK or NG

G

- OK >> Continue preliminary check. Refer to [BCS-16, "BCM Power Supply and Ground Circuit Check"](#) .
- NG >> Change BCM configuration for "DTRL" to "WITH". Refer to [BCS-20, "Configuration"](#) .

H

CHECK POWER SUPPLY AND GROUND CIRCUIT FOR BCM

Refer to [BCS-16, "BCM Power Supply and Ground Circuit Check"](#) .

CHECK POWER SUPPLY AND GROUND CIRCUIT FOR IPDM E/R

Refer to [PG-29, "IPDM E/R Power/Ground Circuit Inspection"](#) .

I

CONSULT-III Function (BCM)

EKS00JN5

Refer to [BCS-18, "CONSULT-III Function \(BCM\)"](#) .

J

CONSULT-III Function (IPDM E/R)

EKS00JN6

Refer to [PG-20, "CONSULT-III Function \(IPDM E/R\)"](#) .

LT

Daytime Light Control Does Not Operate Properly (High Beam Headlamps Operate Properly)

EKS00JN7

L

1. CHECK DAYTIME LIGHT RELAY 1 FUSE

Inspect daytime light relay fuse 10A fuse (No. 27, located in the fuse and fusible link box).

M

OK or NG

- OK >> GO TO 2.
- NG >> Repair harness.

HEADLAMP (FOR CANADA) - DAYTIME LIGHT SYSTEM -

2. CHECK DAYTIME LIGHT RELAY 1 POWER SUPPLY CIRCUIT

1. Turn ignition switch OFF.
2. Remove daytime light relay 1.
3. Check voltage between daytime light relay 1 harness connector E29 terminals 2, 5 and ground.

2, 5 - Ground : Battery voltage should exist.

OK or NG

- OK >> GO TO 3.
NG >> Repair harness or connector.

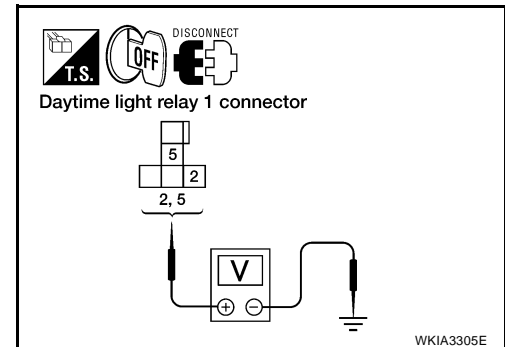

3. CHECK DAYTIME LIGHT RELAY 1

1. Apply battery voltage to daytime light relay 1 terminal 2 and supply ground to terminal 1.
2. Check continuity between terminals 3 and 5.

3 - 5 : Continuity should exist.

OK or NG

- OK >> GO TO 4.
NG >> Replace daytime light relay 1.

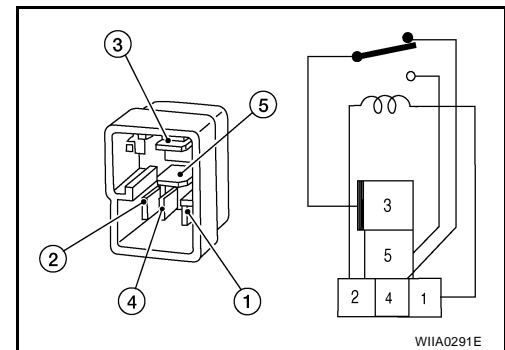

4. CHECK INPUT SIGNAL

1. Connect daytime light relay 1.
2. Start engine and release parking brake. Headlamp switch OFF.
3. Select "IPDM E/R" on CONSULT-III. With DATA MONITOR, make sure "DTRL REQ" turns ON-OFF linked with operation of parking brake switch.

Parking brake ON : DTRL REQ ON
Parking brake OFF : DTRL REQ OFF

OK or NG

- OK >> GO TO 6.
NG >> GO TO 5.

5. CHECKING CAN COMMUNICATIONS

Select "BCM" on CONSULT-III and perform self-diagnosis for BCM.

Displayed self-diagnosis results

- NO DTC>>Replace BCM. Refer to [BCS-21, "Removal and Installation of BCM"](#) .
CAN COMM CIRCUIT>> Check BCM CAN communication system. Refer to [LAN-23, "TROUBLE DIAGNOSIS"](#) .

HEADLAMP (FOR CANADA) - DAYTIME LIGHT SYSTEM -

6. CHECK DAYTIME LIGHT RELAY 1 CONTROL CIRCUIT

1. Turn ignition switch OFF.
2. Disconnect daytime light relay 1 connector E29.
3. Disconnect IPDM E/R connector E47.
4. Check continuity between IPDM E/R connector E47 (A) terminal 49 and daytime light relay 1 connector E29 (B) terminal 1.

A		B		Continuity
Connector	Terminal	Connector	Terminal	
E47	49	E29	1	Yes

OK or NG

- OK >> Replace the IPDM E/R. Refer to [PG-30, "Removal and Installation of IPDM E/R"](#) .
- NG >> Repair harness or connector.

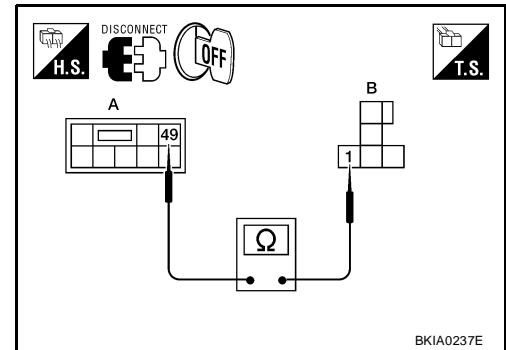

Aiming Adjustment

The headlamp for Canada is the same as the headlamp for USA. Refer to [LT-37, "Aiming Adjustment"](#) .

Bulb Replacement

The headlamp for Canada is the same as the headlamp for USA. Refer to [LT-25, "Bulb Replacement"](#) .

Removal and Installation

The headlamp for Canada is the same as the headlamp for USA. Refer to [LT-25, "Removal and Installation"](#) .

Disassembly and Assembly

The headlamp for Canada is the same as the headlamp for USA. Refer to [LT-26, "Disassembly and Assembly"](#) .

FRONT FOG LAMP

FRONT FOG LAMP

PF2:26150

Component Parts and Harness Connector Location

EKS00JNC

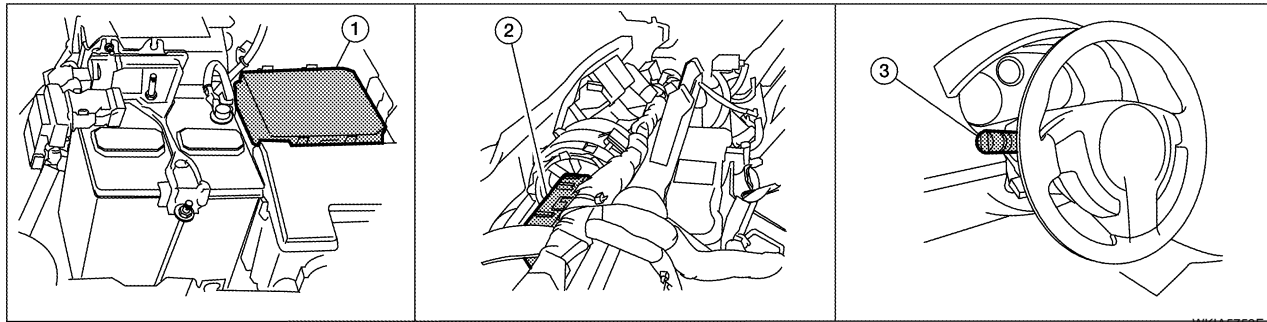

1. IPDM E/R E46, E47 and E48

2. BCM M18 and M20 (viewed with instrument panel removed)

3. Combination switch (lighting switch) M28

System Description

EKS00JND

The front fog lamps are controlled by lighting switch inputs to the BCM (body control module). The lighting switch must be in the 1ST or 2ND position with the high beams OFF before the BCM will request the IPDM E/R (intelligent power distribution module engine room) to turn the front fog lamps on. The BCM requests the front fog lamps over the CAN communication lines to the IPDM E/R. The CPU (central processing unit) of the IPDM E/R controls the front fog lamp relay coil ground. When energized, the relay directs power to the front fog lamps.

OUTLINE

Power is supplied at all times

- to front fog lamp relay (located in IPDM E/R),
- to ignition relay (located in IPDM E/R),
- through 15A fuse (No. 52, located in IPDM E/R) and
- through 20A fuse (No. 53, located in IPDM E/R)
- to CPU located in IPDM E/R,
- through 50A fusible link (letter j , located in the fuse and fusible link box)
- to BCM terminal 70,
- through 10A fuse [No. 21, located in fuse block (J/B)]
- to BCM terminal 57.

With the ignition switch in the ON or START position, power is supplied

- to ignition relay (located in IPDM E/R),
- through 10A fuse [No. 12, located in fuse block (J/B)]
- to BCM terminal 38.

With the ignition switch in the ACC or ON position, power is supplied

- through 10A fuse [No. 6, located in fuse block (J/B)]
- to BCM terminal 11.

Ground is supplied

- to BCM terminal 67
- through grounds M57 and M61,
- to IPDM E/R terminals 39 and 59
- through grounds E9, E15 (all models) and E24 (with MR20DE).

FOG LAMP OPERATION

The front fog lamp switch is built into the lighting switch. The lighting switch must be in 1ST position or 2ND position and front fog lamp switch must be in the ON position for front fog lamp operation. The fog lamp will not operate with the high beam headlamps ON.

FRONT FOG LAMP

When the front fog lamp switch is in the ON position, the BCM sends a request, via the CAN communication lines, to the CPU of the IPDM E/R to ground the coil side of the front fog lamp relay. The front fog lamp relay then directs power

- through 15A fuse (No. 56, located in IPDM E/R)
- through IPDM E/R terminal 50
- to front fog lamp LH terminal 1, and
- through IPDM E/R terminal 51
- to front fog lamp RH terminal 1.

Ground is supplied

- to front fog lamp LH and RH terminal 2,
- through grounds E9, E15 (all models) and E24 (with MR20DE).

With power and ground supplied, front fog lamps illuminate.

COMBINATION SWITCH READING FUNCTION

Refer to [LT-65, "Combination Switch Reading Function"](#) .

CAN Communication System Description

Refer to [LAN-4, "SYSTEM DESCRIPTION"](#) .

A

B

C

D

E

EKS00JNE

F

G

H

I

J

LT

L

M

FRONT FOG LAMP

Wiring Diagram — F/FOG —

EKS00JNF

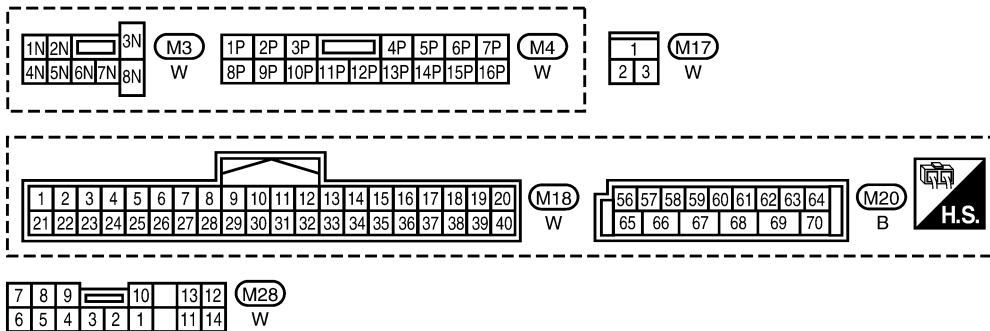
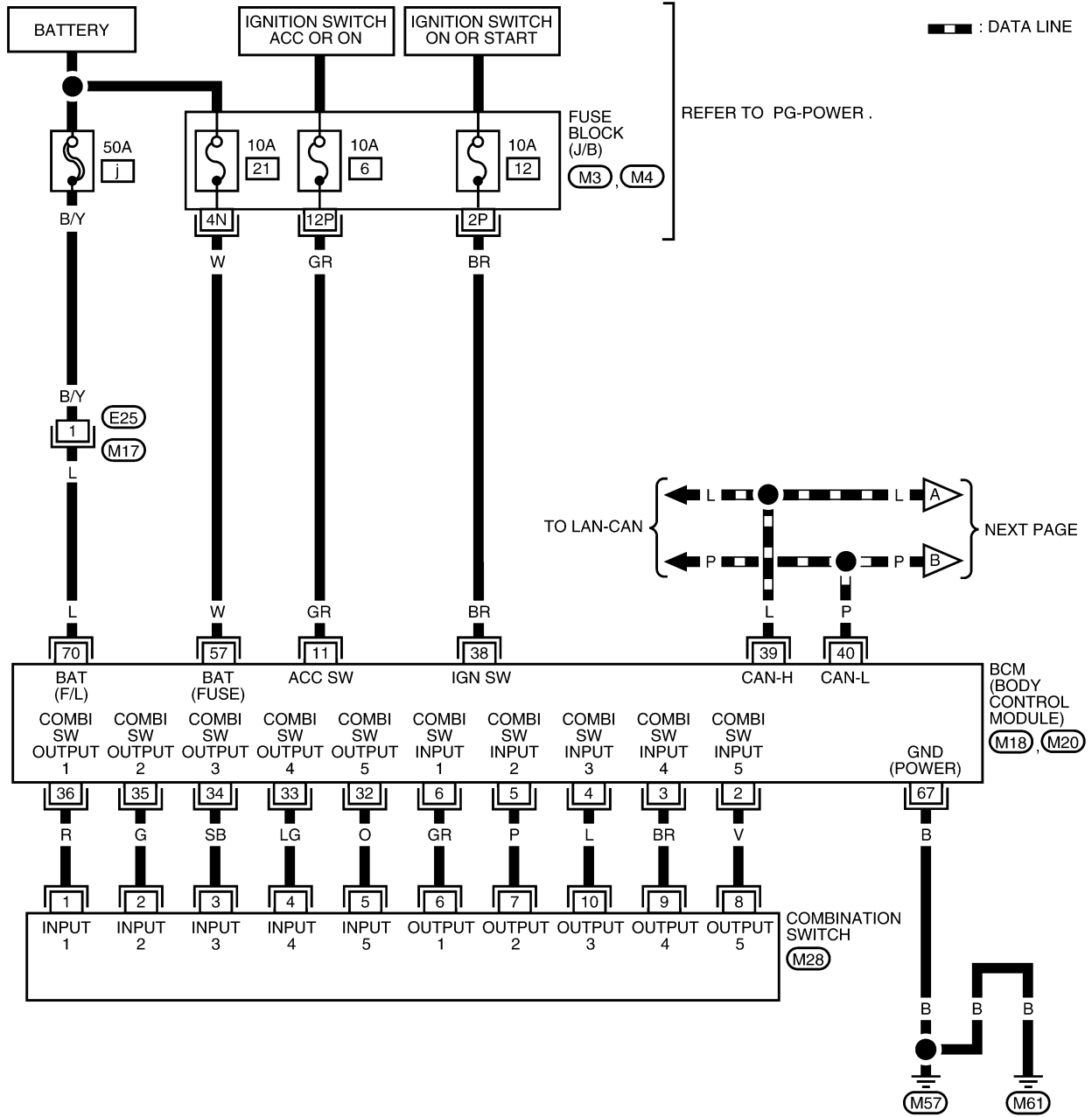

LT-F/FOG-01



BKWA0789E

FRONT FOG LAMP

LT-F/FOG-02

 : DATA LINE
 : WITH MR20DE

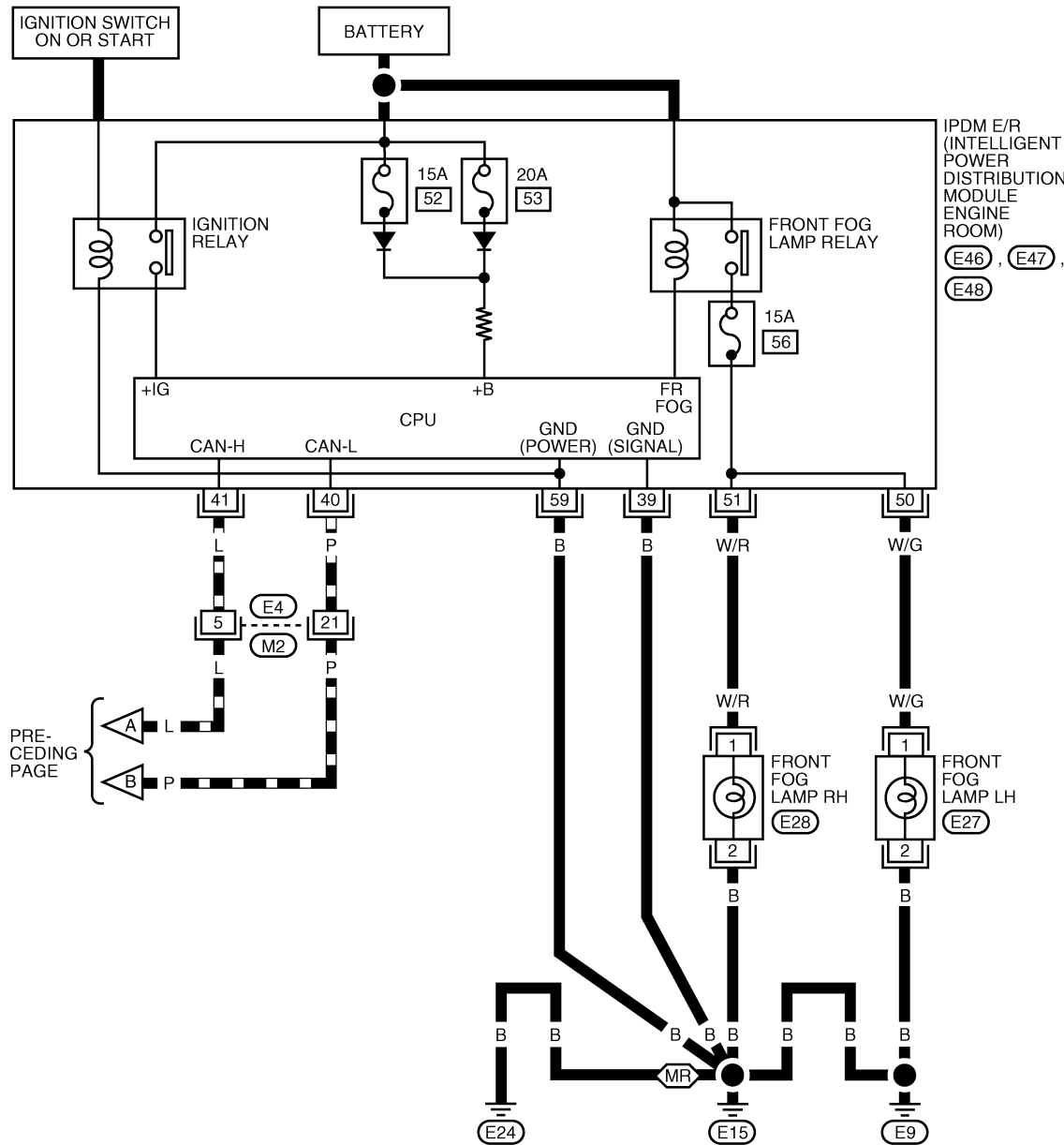

A
B
C
D
E
F
G
H
I
J
LT
L
M

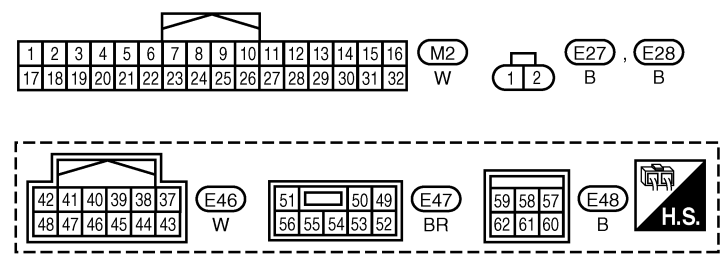

BKWA0836E

FRONT FOG LAMP

Terminals and Reference Values for BCM

EKS00JNG

Refer to [BCS-13, "Terminals and Reference Values for BCM"](#) .

Terminals and Reference Values for IPDM E/R

EKS00JNH

Refer to [PG-26, "Terminals and Reference Values for IPDM E/R"](#) .

How to Proceed With Trouble Diagnosis

EKS00JNI

1. Confirm the symptom or customer complaint.
2. Understand operation description and function description. Refer to [LT-38, "System Description"](#) .
3. Perform the Preliminary Check. Refer to [LT-42, "Preliminary Check"](#) .
4. Check symptom and repair or replace the cause of the malfunction.
5. Do the front fog lamps operate normally? If YES, GO TO 6. If NO, GO TO 4.
6. Inspection end.

Preliminary Check

EKS00JNJ

CHECK POWER SUPPLY AND GROUND CIRCUIT FOR BCM

Refer to [BCS-16, "BCM Power Supply and Ground Circuit Check"](#) .

CHECK POWER SUPPLY AND GROUND CIRCUIT FOR IPDM E/R

Refer to [PG-29, "IPDM E/R Power/Ground Circuit Inspection"](#) .

CONSULT-III Function (BCM)

EKS00JNK

Refer to [BCS-18, "CONSULT-III Function \(BCM\)"](#) .

CONSULT-III Function (IPDM E/R)

EKS00JNL

Refer to [PG-20, "CONSULT-III Function \(IPDM E/R\)"](#) .

Front Fog lamps Do Not Illuminate (Both Sides)

EKS00JNM

1. INSPECT FOG LAMP FUSE

Inspect fog lamp 15A fuse (No. 56, located in IPDM E/R).

OK or NG

- OK >> GO TO 2.
- NG >> Repair harness.

2. CHECK COMBINATION SWITCH INPUT SIGNAL

With CONSULT-III

1. Select "BCM" on CONSULT-III. Select "HEAD LAMP" on "SELECT TEST ITEM" screen.
2. Select "DATA MONITOR". Make sure that "FR FOG SW" turns ON-OFF linked with operation of fog lamp switch.

When fog lamp switch is ON : FR FOG SW ON

Without CONSULT-III

Refer to [LT-65, "Combination Switch Inspection"](#) .

OK or NG

- OK >> GO TO 3.
- NG >> Check combination switch (lighting switch). Refer to [LT-65, "Combination Switch Inspection"](#) .

FRONT FOG LAMP

3. FOG LAMP ACTIVE TEST

With CONSULT-III

1. Select "IPDM E/R" on CONSULT-III. Select "ACTIVE TEST".
2. Select "LAMPS" on "SELECT TEST ITEM" screen.
3. Touch "FOG" screen.
4. Make sure front fog lamp operates.

Front fog lamp should operate.

Without CONSULT-III

1. Start auto active test. Refer to [PG-22, "Auto Active Test"](#) .
2. Make sure front fog lamp operates.

Front fog lamp should operate.

OK or NG

- OK >> GO TO 4.
NG >> GO TO 5.

4. CHECK IPDM E/R

1. Select "IPDM E/R" on CONSULT-III. Select "DATA MONITOR".
2. Make sure "FR FOG REQ" turns ON when front fog lamp switch is in ON position.

When front fog lamp switch is ON : FR FOG REQ ON

OK or NG

- OK >> Replace IPDM E/R. Refer to [PG-30, "Removal and Installation of IPDM E/R"](#) .
NG >> Replace BCM. Refer to [BCS-21, "Removal and Installation of BCM"](#) .

A

B

C

D

E

F

G

H

I

J

LT

L

M

FRONT FOG LAMP

5. CHECK FOG LAMP INPUT SIGNAL

④ With CONSULT-III

1. Turn ignition switch OFF.
2. Disconnect front fog lamp connector.
3. Turn ignition switch ON.
4. Select "IPDM E/R" on CONSULT-III, and select "ACTIVE TEST".
5. Select "LAMPS" on "SELECT TEST ITEM" screen.
6. Touch "FOG" screen.
7. When front fog lamp relay is operating, check voltage between front fog lamp harness connector and ground.

(+)		Terminal	(-)	Voltage
Front fog lamp connector				
RH	E28	1	Ground	Battery voltage
LH	E27			

⊗ Without CONSULT-III

1. Turn ignition switch OFF.
2. Disconnect front fog lamp connector.
3. Turn ignition switch ON.
4. Start auto active test. Refer to [PG-22, "Auto Active Test"](#) .
5. When front fog lamp relay is operating, check voltage between front fog lamp harness connector and ground.

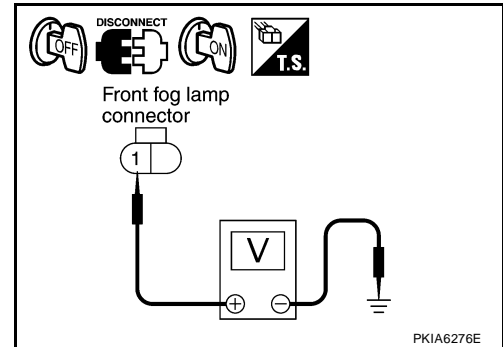

(+)		Terminal	(-)	Voltage
Front fog lamp connector				
RH	E28	1	Ground	Battery voltage
LH	E27			

OK or NG

- OK >> GO TO 7.
 NG >> GO TO 6.

6. CHECK FOG LAMP CIRCUIT

1. Turn ignition switch OFF.
2. Disconnect IPDM E/R connector.
3. Check continuity between IPDM E/R harness connector (A) and front fog lamp harness connector (B).

Circuit	A		B		Continuity
	Connector	Terminal	Connector	Terminal	
RH	E47	51	E28	1	Yes
LH		50	E27		

OK or NG

- OK >> Replace IPDM E/R. Refer to [PG-30, "Removal and Installation of IPDM E/R"](#) .
 NG >> Repair harness or connector.

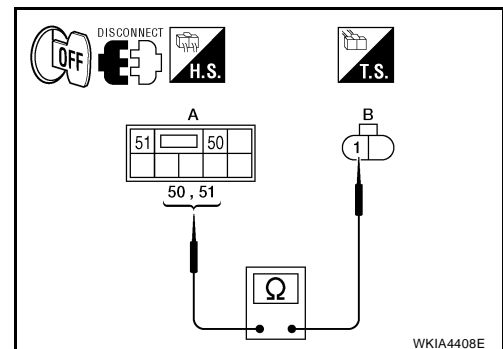

FRONT FOG LAMP

7. CHECK FOG LAMP GROUND

1. Check continuity between front fog lamp harness connector and ground.

Front fog lamp connector		Terminal	Ground	Continuity
RH	E28	2		Ground
LH	E27			

OK or NG

- OK >> Check front fog lamp bulbs.
 NG >> Repair harness or connector.

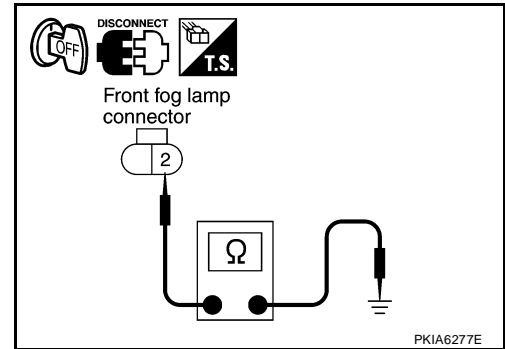

Front Fog Lamp Does Not Illuminate (One Side)

1. CHECK BULB

Check bulb of lamp which does not illuminate.

OK or NG

- OK >> GO TO 2.
 NG >> Replace front fog lamp bulb. Refer to [LT-46, "Bulb Replacement"](#).

2. CHECK FOG LAMP CIRCUIT

1. Turn ignition switch OFF.
2. Disconnect IPDM E/R connector and front fog lamp connector.
3. Check continuity between IPDM E/R harness connector (A) and front fog lamp harness connector (B).

Circuit	A		B		Continuity
	Connector	Terminal	Connector	Terminal	
RH	E47	51	E28	1	Yes
LH		50	E27		

OK or NG

- OK >> GO TO 3.
 NG >> Repair harness or connector.

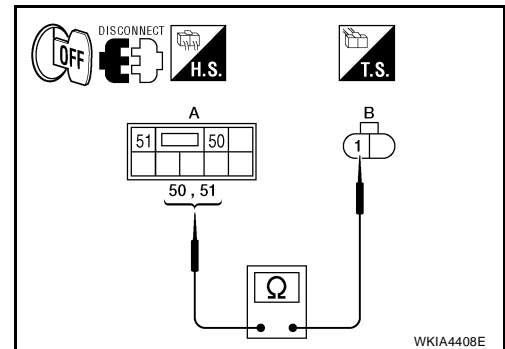

3. CHECK FOG LAMP GROUND

Check continuity between front fog lamp harness connector and ground.

Front fog lamp connector		Terminal	Ground	Continuity
RH	E28	2		Ground
LH	E27			

OK or NG

- OK >> Replace IPDM E/R. Refer to [PG-30, "Removal and Installation of IPDM E/R"](#).
 NG >> Repair harness or connector.

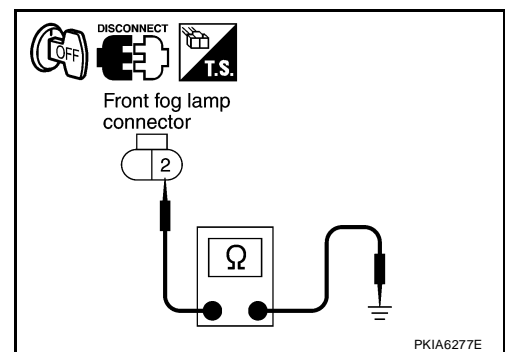

FRONT FOG LAMP

Aiming Adjustment

EKS00JNO

The front fog lamp is a semi-sealed beam type which uses a replaceable halogen bulb. Before performing aiming adjustment, make sure of the following.

- Keep all tires inflated to correct pressure.
- Place vehicle on level surface.
- Set that there is no-load in vehicle other than the driver (or equivalent weight placed in driver's position). Coolant, engine oil filled up to correct level and full fuel tank.

Adjust aiming in the vertical direction by turning the adjusting screw (A).

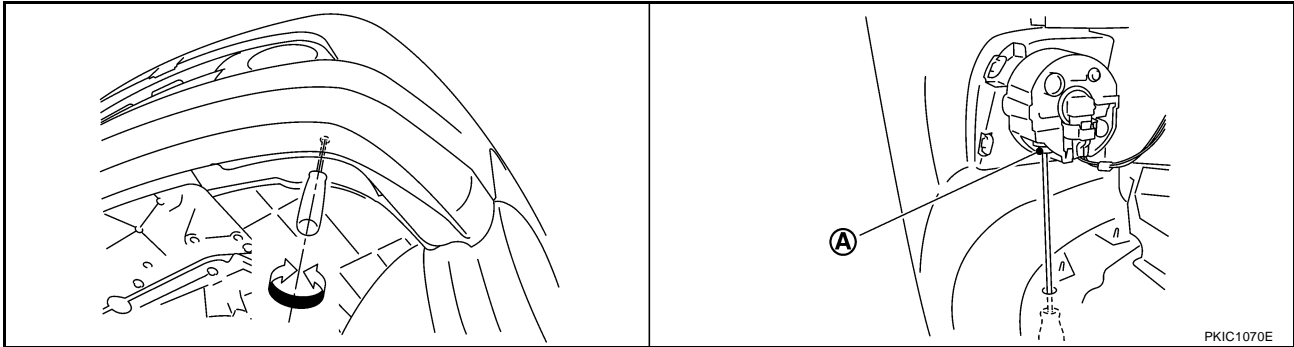

1. Set the distance (D) between the screen and the center of front fog lamp lens as shown.
2. Turn front fog lamps to ON.
3. Adjust front fog lamps using adjusting screw so that the top edge of the high intensity zone (C) is as shown.

Horizontal distance from horizontal/vertical center point of fog lamp on screen to top edge of high intensity zone (A)	100 mm (4 in)
Horizontal/vertical center point of fog lamp	(B)
Foglamp high intensity zone	(C)
Distance from foglamp to screen (D)	7.62 mm (25 ft)

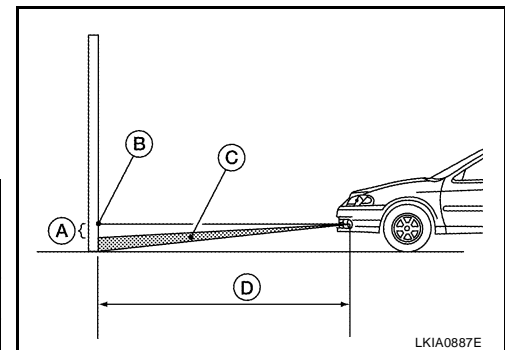

NOTE:

When performing adjustment, if necessary, cover the headlamps and opposite front fog lamp.

Bulb Replacement

EKS00JNP

1. Turn lighting switch OFF.
2. Position back the front fender protector. Refer to [EI-22, "Removal and Installation"](#) .
3. Disconnect front fog lamp connector (1).
4. Turn bulb socket (2) counterclockwise unlock and remove it.
5. Remove bulb from its socket.

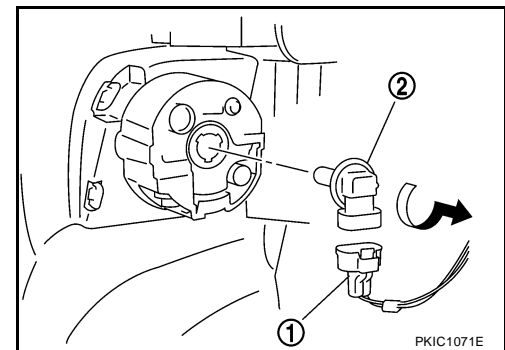

Removal and Installation, All Except SE-R REMOVAL

EKS00JNQ

1. Remove the fender protector. Refer to [EI-21, "FENDER PROTECTOR"](#) .

FRONT FOG LAMP

2. Disconnect the front fog lamp connector (3) from the fog lamp bulb (1).
3. Remove the front fog lamp screws (A) and remove the front fog lamp (2).
 - As necessary, remove the two staples attaching the base of the fog lamp (2) and discard the staples.

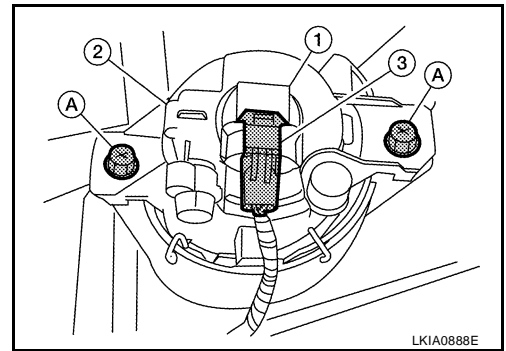

INSTALLATION

Installation is in the reverse order of removal.

Removal and Installation, SE-R REMOVAL

EKS00L4Y

1. Disconnect the front fog lamp connector (1) from the fog lamp bulb (2).
2. Remove the front fog lamp screws (A) and remove the front fog lamp (3).

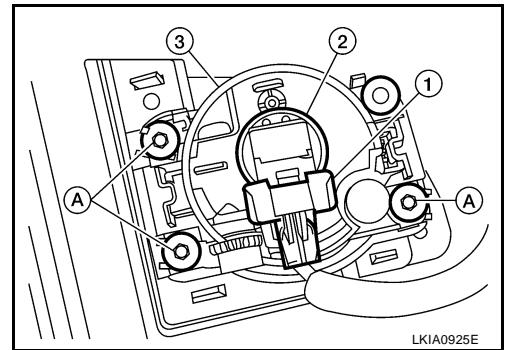

INSTALLATION

Installation is in the reverse order of removal.

A
B
C
D
E
F
G
H
I
J
LT
L
M

TURN SIGNAL AND HAZARD WARNING LAMPS

TURN SIGNAL AND HAZARD WARNING LAMPS

PF2:26120

Component Parts and Harness Connector Location

EKS00JNR

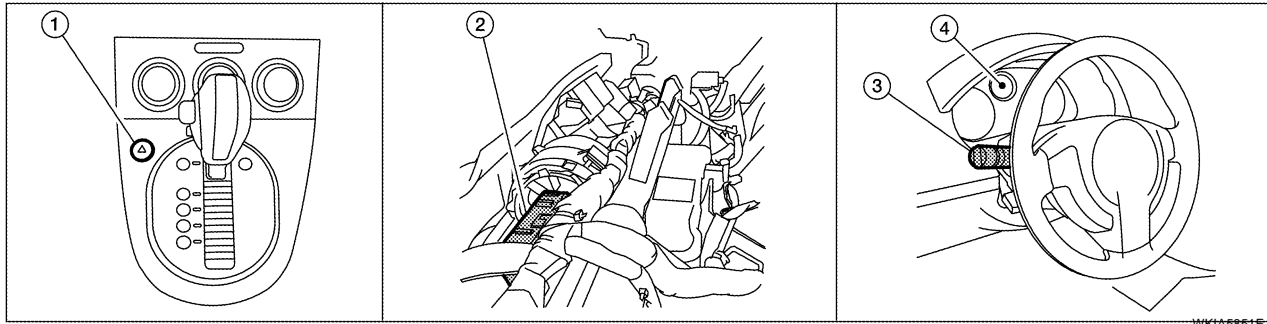

1. Hazard switch M102

2. BCM M18 and M20 (view with instrument panel removed)

3. Combination switch (lighting switch) M28

4. Combination meter M24

System Description

TURN SIGNAL OPERATION

EKS00JNS

Power is supplied at all times

- through 50A fusible link (letter j , located in the fuse and fusible link box)
- to BCM (body control module) terminal 70,
- through 10A fuse [No. 21, located in the fuse block (J/B)]
- to BCM terminal 57,
- through 10A fuse [No. 19, located in the fuse block (J/B)]
- to combination meter terminal 1.

With the ignition switch in the ON or START position, power is supplied

- through 10A fuse [No. 12, located in fuse block (J/B)]
- to BCM terminal 38,
- through 10A fuse [No. 14, located in fuse block (J/B)]
- to combination meter terminal 2.

With the ignition switch in the ACC or ON position, power is supplied

- through 10A fuse [No. 6, located in the fuse block (J/B)]
- to BCM terminal 11.

Ground is supplied

- to BCM terminal 67 and
- to combination meter terminals 3 and 21
- through grounds M57 and M61.

LH Turn Signal Lamp

When the turn signal switch is moved to the left turn position, the BCM receives an input signal requesting left turn signals to flash. The BCM then supplies power

- through BCM terminal 60
- to front combination lamp LH terminal 4 and
- to rear combination lamp LH terminal 6.

Ground is supplied

- to front combination lamp LH terminal 2
- through grounds E9, E15 (all models) and E24 (with MR20DE),
- to rear combination lamp LH terminal 4
- through grounds B7 and B19.

TURN SIGNAL AND HAZARD WARNING LAMPS

The BCM also sends a request, via the CAN communication lines, to the combination meter to flash the left turn signal indicator. The unified meter control unit in the combination meter supplies ground to the left turn signal indicator lamp and activates the audible turn signal indicator.

With power, ground and input supplied, the BCM controls the flashing of the turn signal lamps.

RH Turn Signal Lamp

When turn signal switch is moved to the right turn position, the BCM receives an input signal requesting right turn signals to flash. The BCM then supplies power

- through BCM terminal 61
- to front combination lamp RH terminal 4 and
- to rear combination lamp RH terminal 6.

Ground is supplied

- to front combination lamp RH terminal 2
- through grounds E9, E15 (all models) and E24 (with MR20DE),
- to rear combination lamp RH terminal 4
- through grounds B7 and B19.

The BCM also sends a request, via the CAN communication lines, to the combination meter to flash the right turn signal indicator. The unified meter control unit in the combination meter supplies ground to the right turn signal indicator lamp and activates the audible turn signal indicator.

With power, ground and input supplied, the BCM controls the flashing of the turn signal lamps.

HAZARD LAMP OPERATION

Power is supplied at all times

- through 50A fusible link (letter j , located in fuse, fusible link and relay box)
- to BCM terminal 70,
- through 10A fuse [No. 21, located in fuse block (J/B)]
- to BCM terminal 57,
- through 10A fuse [No. 19, located in fuse block (J/B)]
- to combination meter terminal 1.

Ground is supplied

- to hazard switch terminal 1,
- to BCM terminal 67, and
- to combination meter terminals 3 and 21
- through grounds M57 and M61.

When hazard switch is depressed, ground is supplied

- through hazard switch terminal 2
- to BCM terminal 29.

BCM then supplies power

- to front combination lamp LH terminal 4 and
- to rear combination lamp LH terminal 6
- through BCM terminal 60,
- to front combination lamp RH terminal 4 and
- to rear combination lamp RH terminal 6
- through BCM terminal 61.

Ground is supplied

- to front combination lamp LH and RH terminal 2
- through grounds E9, E15 (all models) and E24 (with MR20DE),
- to rear combination lamp LH and RH terminal 4
- through grounds B7 and B19.

The BCM also supplies input to combination meter across the CAN communication lines. This input is processed by unified meter control unit in combination meter, which in turn supplies ground to the left and right turn signal indicator lamps.

A

B

C

D

E

F

G

H

I

J

LT

L

M

TURN SIGNAL AND HAZARD WARNING LAMPS

With power and input supplied, BCM controls flashing of hazard warning lamps.

REMOTE KEYLESS ENTRY SYSTEM OPERATION

Power is supplied at all times

- through 50A fusible link (letter j , located in fuse, fusible link and relay box)
- to BCM terminal 70,
- through 10A fuse [No. 19, located in fuse block (J/B)]
- to combination meter terminal 1.

Ground is supplied

- to BCM terminal 67 and
- to combination meter terminals 3 and 21
- through grounds M57 and M61.

When the remote keyless entry system is triggered by input from the keyfob, the BCM supplies power

- through BCM terminal 60
- to front combination lamp LH terminal 4 and
- to rear combination lamp LH terminal 6,
- through BCM terminal 61
- to front turn signal lamp RH terminal 4 and
- to rear combination lamp RH terminal 6.

Ground is supplied

- to front combination lamp LH and RH terminal 2
- through grounds E9, E15 (all models) and E24 (with MR20DE),
- to rear combination lamp LH and RH terminal 4
- through grounds B7 and B19.

The BCM also supplies input to combination meter via the CAN communication lines. This input is processed by the unified meter control unit in combination meter, which in turn supplies ground to the left and right turn signal indicator lamps.

With power and ground supplied, BCM controls flashing of hazard warning lamps when keyfob is used to activate remote keyless entry system.

COMBINATION SWITCH READING FUNCTION

Refer to [LT-65, "Combination Switch Reading Function"](#) .

CAN Communication System Description

Refer to [LAN-4, "SYSTEM DESCRIPTION"](#) .

EKS00JNT

TURN SIGNAL AND HAZARD WARNING LAMPS

Schematic

EKS00JNU

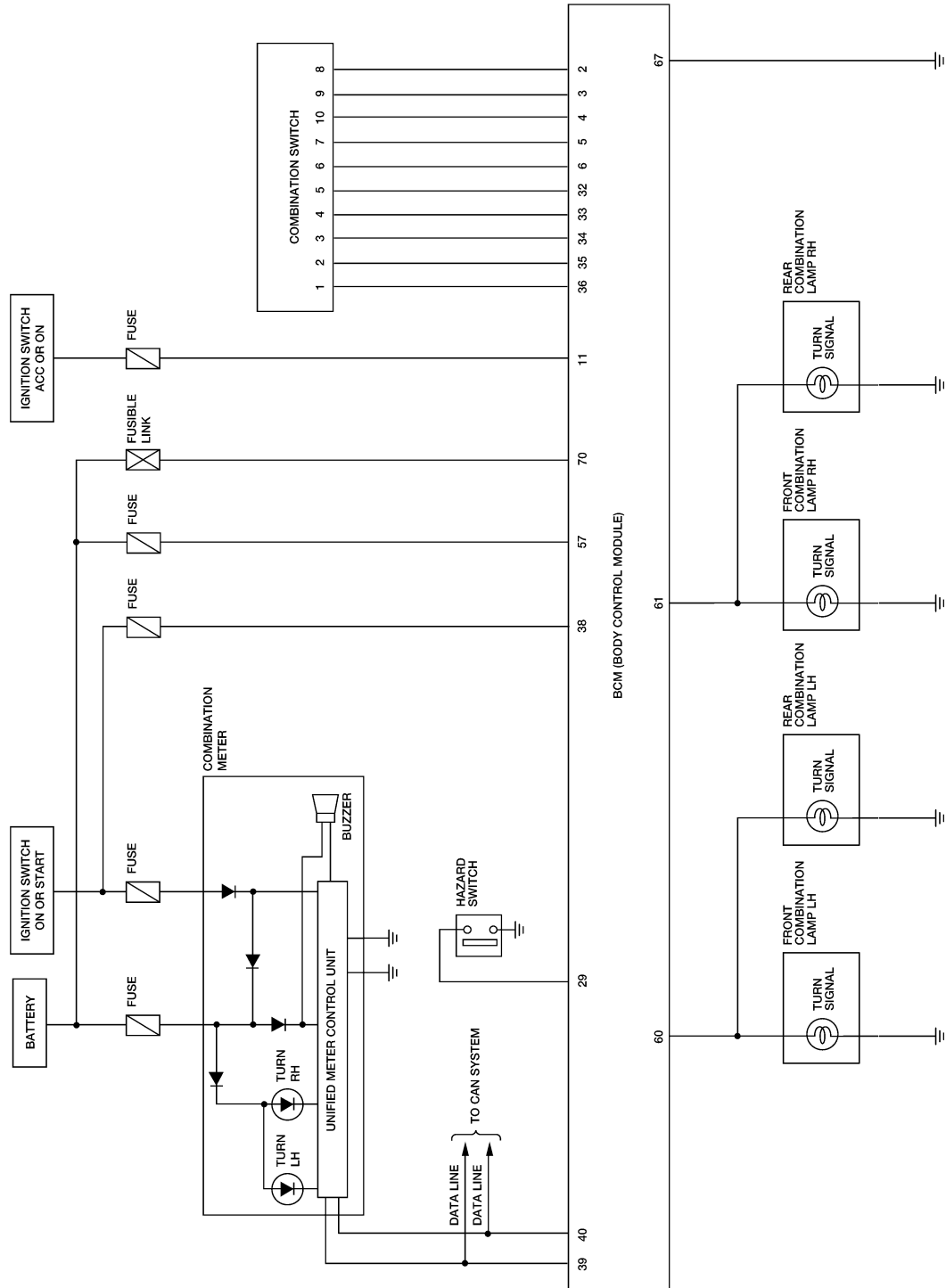

A
B
C
D
E
F
G
H
I
J
LT
L
M

BKWA0791E

TURN SIGNAL AND HAZARD WARNING LAMPS

Wiring Diagram — TURN —

EKS00JNV

LT-TURN-01

▬ : DATA LINE

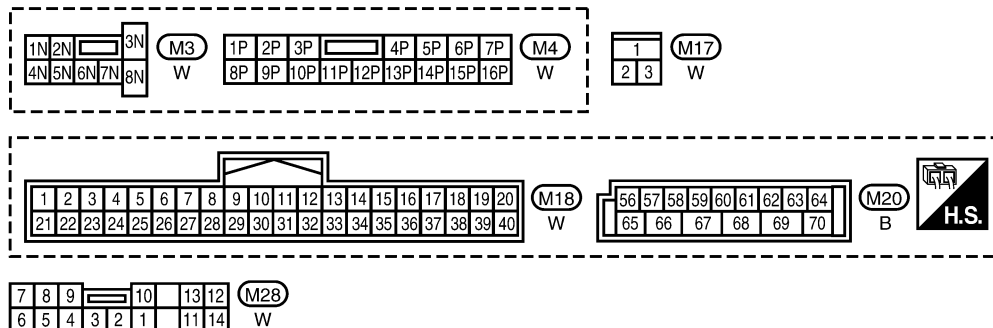
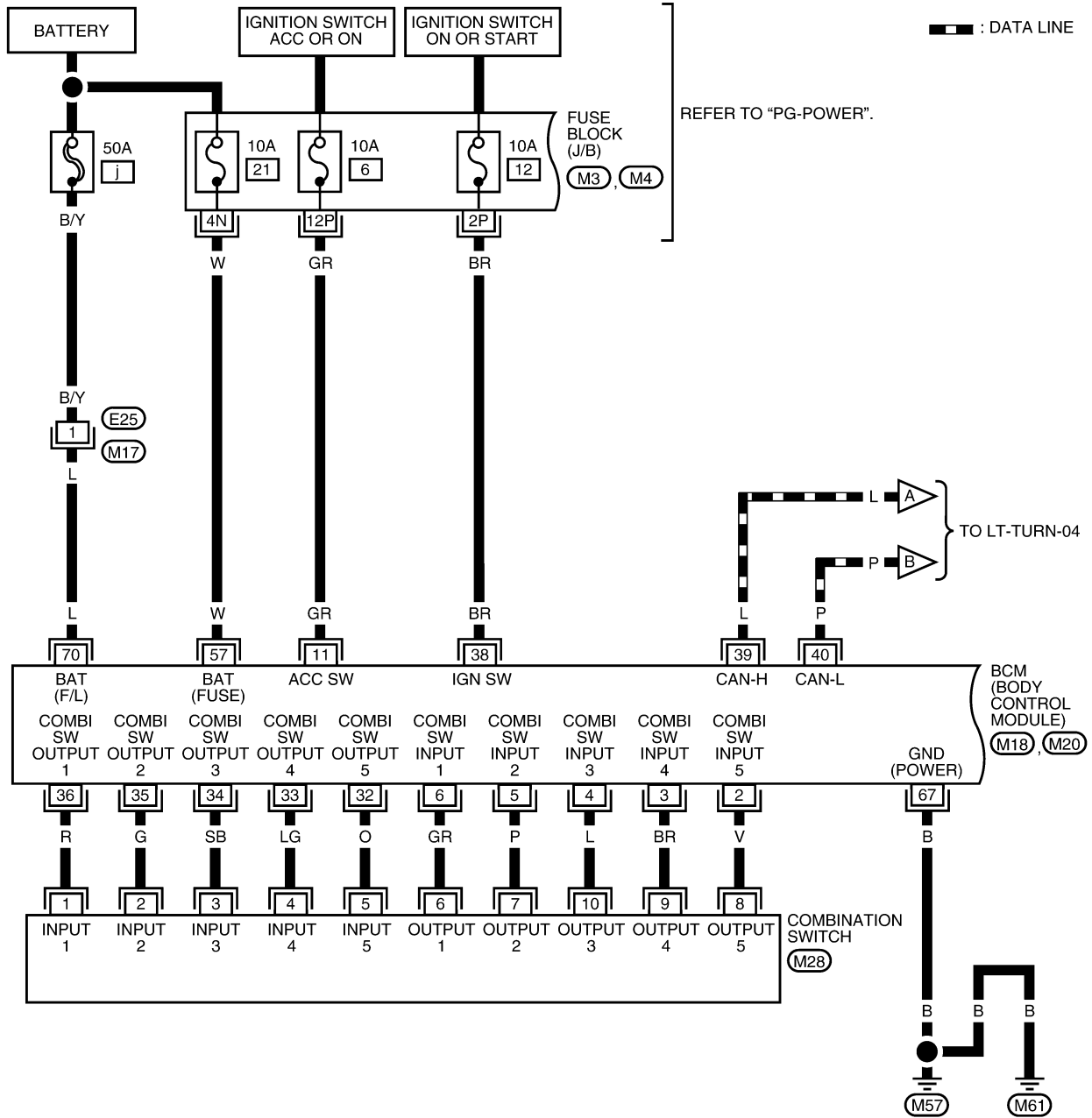

BKWA0792E

TURN SIGNAL AND HAZARD WARNING LAMPS

LT-TURN-02

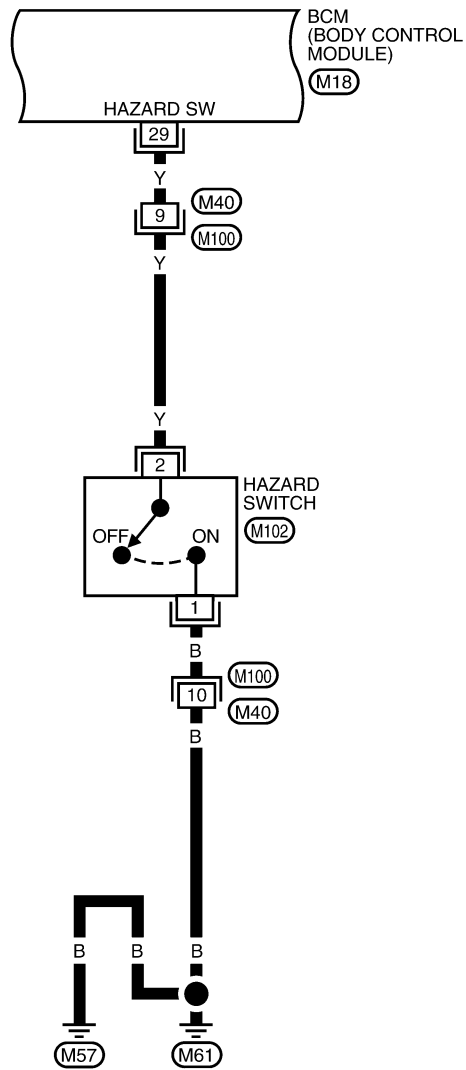

A
B
C
D
E
F
G
H
I
J
LT
L
M

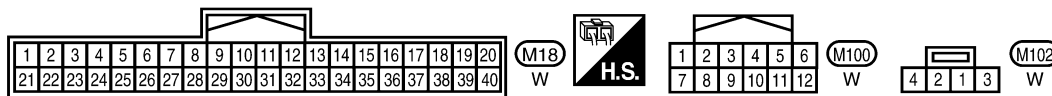

BKWA0793E

TURN SIGNAL AND HAZARD WARNING LAMPS

LT-TURN-03

MR : WITH MR20DE

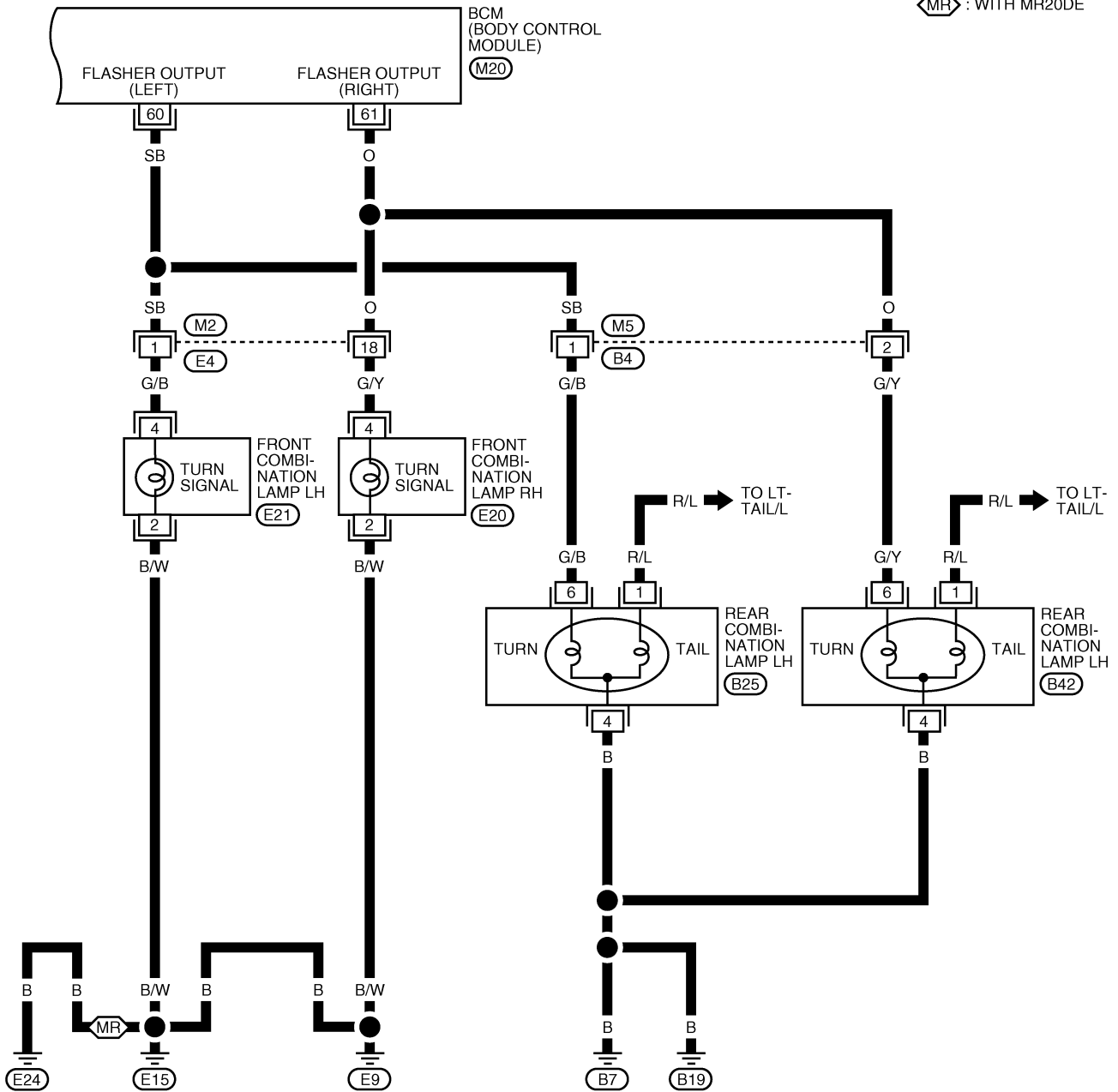

1	2	3	4	5	6	7	8	9	10	11	12	13	14	15	16
17	18	19	20	21	22	23	24	25	26	27	28	29	30	31	32

(M2) W

1	2	3	4	5	6	7		
8	9	10	11	12	13	14	15	16

(M5) GR

56	57	58	59	60	61	62	63	64
65	66	67	68	69	70			

(M20) B



1	2	3
4	5	6

(E20) GR, (E21) GR

2	1		
6	5	4	3

(B25) W, (B42) W

BKWA0837E

TURN SIGNAL AND HAZARD WARNING LAMPS

LT-TURN-04

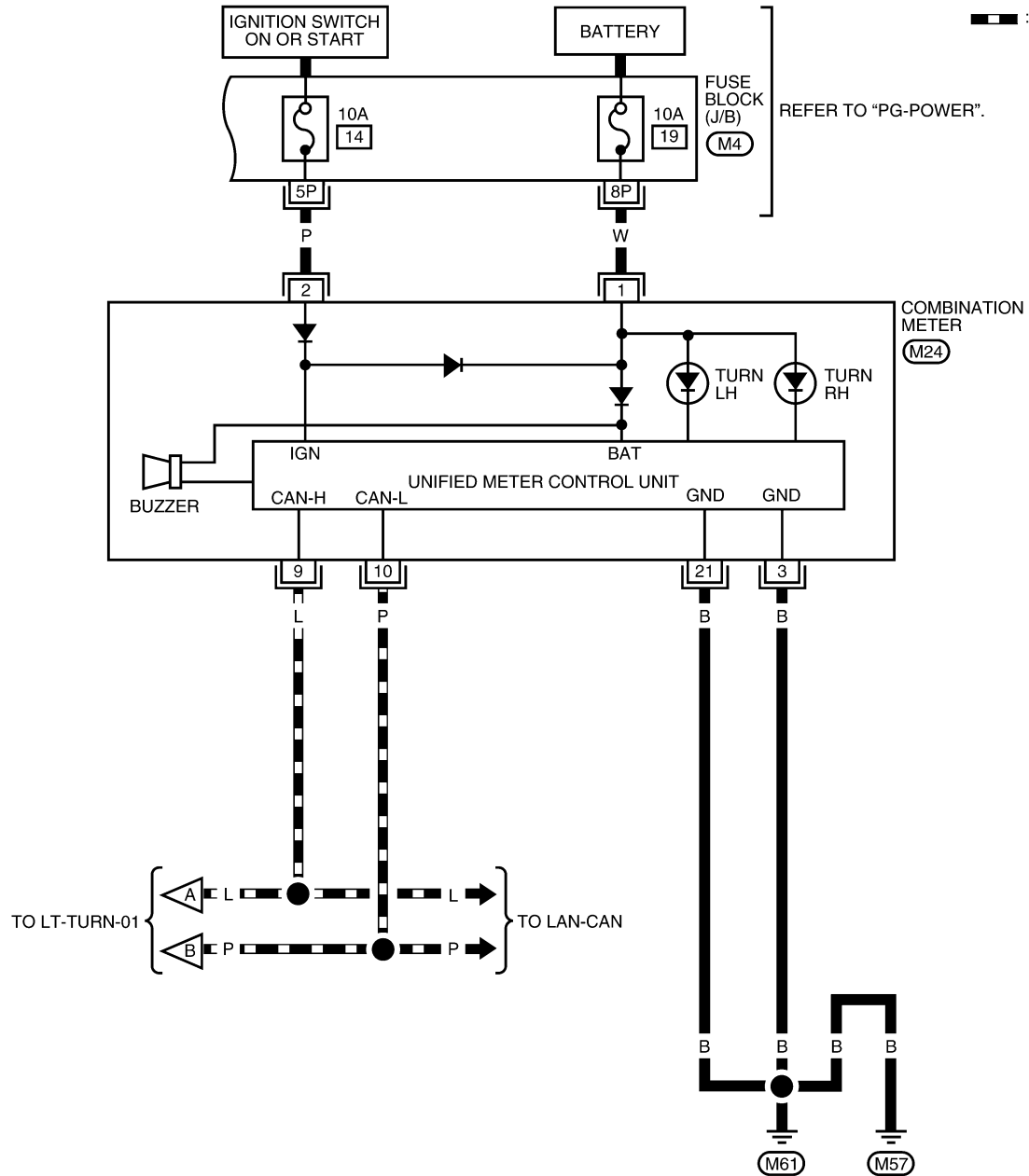

A
B
C
D
E
F
G
H
I
J
LT
L
M

1P	2P	3P	4P	5P	6P	7P	(M4)	20	19	18	17	16	15	14	13	12	11	10	9	8	7	6	5	4	3	2	1	(M24)		
8P	9P	10P	11P	12P	13P	14P	15P	16P	W	40	39	38	37	36	35	34	33	32	31	30	29	28	27	26	25	24	23	22	21	W

BKWA0795E

TURN SIGNAL AND HAZARD WARNING LAMPS

Terminals and Reference Values for BCM

EKS00JNW

Refer to [BCS-13, "Terminals and Reference Values for BCM"](#) .

How to Proceed With Trouble Diagnosis

EKS00JNX

1. Confirm the symptom or customer complaint.
2. Understand operation description and function description. Refer to [LT-48, "System Description"](#) .
3. Perform the preliminary check. Refer to [LT-56, "Preliminary Check"](#) .
4. Check symptom and repair or replace the cause of the malfunction.
5. Do turn signal and hazard warning lamps operate normally? If YES, GO TO 6. If NO, GO TO 4.
6. INSPECTION END

Preliminary Check

EKS00JNY

CHECK POWER SUPPLY AND GROUND CIRCUIT FOR BCM

Refer to [BCS-16, "BCM Power Supply and Ground Circuit Check"](#) .

CONSULT-III Function (BCM)

EKS00JNZ

Refer to [BCS-18, "CONSULT-III Function \(BCM\)"](#) .

Turn Signals Do Not Operate

EKS00JO0

1. CHECK COMBINATION SWITCH INPUT SIGNAL

① With CONSULT-III

1. Select "BCM" on CONSULT-III. Select "FLASHER" on "SELECT TEST ITEM" screen.
2. Select "DATA MONITOR". Make sure that "TURN SIGNAL R" and "TURN SIGNAL L" turn ON-OFF linked with operation of lighting switch.

**When turn signal switch is : TURN SIGNAL R ON
right position**

**When turn signal switch is : TURN SIGNAL L ON
left position**

② Without CONSULT-III

Refer to [LT-65, "Combination Switch Inspection"](#) .

OK or NG

OK >> Replace the BCM. Refer to [BCS-21, "Removal and Installation of BCM"](#) .

NG >> Check combination switch (lighting switch). Refer to [LT-65, "Combination Switch Inspection"](#) .

Front Turn Signal Lamp Does Not Operate

EKS00JO1

1. CHECK BULB

Verify the bulb standard of each turn signal lamp is correct. Refer to [LT-111, "Exterior Lamp"](#) .

OK or NG

OK >> GO TO 2.

NG >> Replace turn signal lamp bulb. Refer to [LT-61, "Bulb Replacement of Front Turn Signal Lamp"](#) .

TURN SIGNAL AND HAZARD WARNING LAMPS

2. CHECK FRONT TURN SIGNAL LAMP CIRCUIT

1. Turn ignition switch OFF.
2. Disconnect BCM connector and front combination lamp LH or RH connector.
3. Check continuity between BCM harness connector M20 (A) terminal 60 and front combination lamp LH harness connector E21 (B) terminal 4.

60 - 4 : Continuity should exist.

4. Check continuity between BCM harness connector M20 (A) terminal 61 and front combination lamp RH harness connector E20 (B) terminal 4.

61 - 4 : Continuity should exist.

OK or NG

OK >> GO TO 3.

NG >> Repair harness or connector.

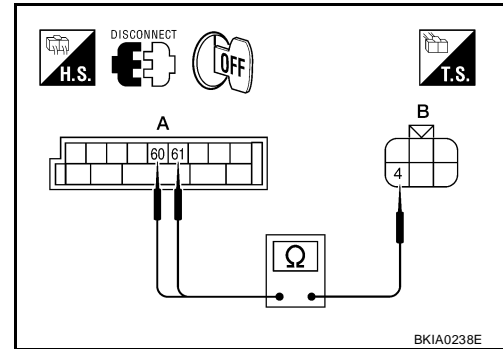

3. CHECK GROUND CIRCUIT

1. Check continuity between front combination lamp LH harness connector E21 terminal 2 and ground.

2 - Ground : Continuity should exist.

2. Check continuity between front combination lamp RH harness connector E20 terminal 2 and ground.

2 - Ground : Continuity should exist.

OK or NG

OK >> Inspect connection at front combination lamp.

NG >> Repair harness.

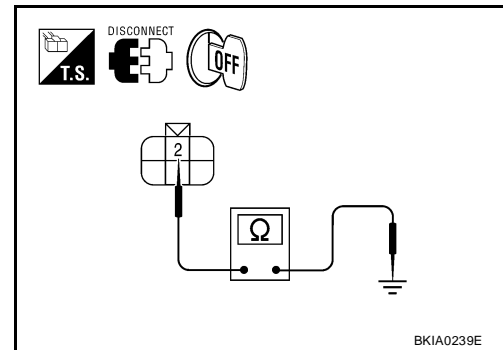

Rear Turn Signal Lamp Does Not Operate

EKS00J02

1. CHECK BULB

Verify the bulb standard of each turn signal lamp is correct. Refer to [LT-111, "Exterior Lamp"](#).

OK or NG

OK >> GO TO 2.

NG >> Replace turn signal lamp bulb. Refer to [LT-61, "Bulb Replacement of Rear Turn Signal Lamp"](#).

TURN SIGNAL AND HAZARD WARNING LAMPS

2. CHECK REAR TURN SIGNAL LAMP CIRCUIT

1. Turn ignition switch OFF.
2. Disconnect BCM connector and rear combination lamp LH or RH connector.
3. Check continuity between BCM harness connector M20 (A) terminal 60 and rear combination lamp LH harness connector B25 (B) terminal 6.

60 - 6 : Continuity should exist.

4. Check continuity between BCM harness connector M20 (A) terminal 61 and rear combination lamp RH harness connector B42 (B) terminal 6.

61 - 6 : Continuity should exist.

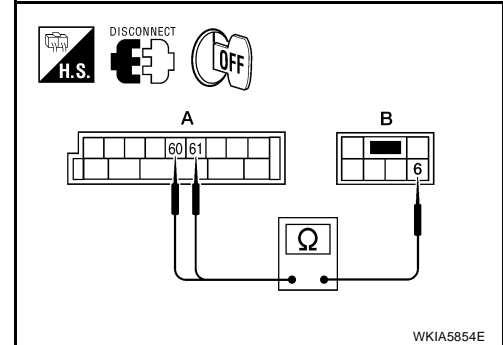

OK or NG

OK >> GO TO 3.

NG >> Repair harness or connector.

3. CHECK GROUND CIRCUIT

1. Check continuity between rear combination lamp LH harness connector B25 terminal 4 and ground.

4 - Ground : Continuity should exist.

2. Check continuity between rear combination lamp RH harness connector B42 terminal 4 and ground.

4 - Ground : Continuity should exist.

OK or NG

OK >> Check rear combination lamp connector for proper connection. Repair as necessary.

NG >> Repair harness or connector.

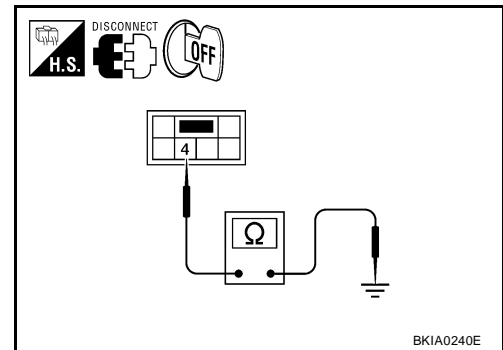

TURN SIGNAL AND HAZARD WARNING LAMPS

EKS00J03

Hazard Warning Lamp Does Not Operate But Turn Signal Lamp Operates

1. CHECK HAZARD SWITCH INPUT SIGNAL

④ With CONSULT-III

1. Select "BCM" on CONSULT-III. Select "FLASHER" on "SELECT TEST ITEM" screen.
2. Select "DATA MONITOR". Make sure that "HAZARD SW" turns ON-OFF linked with operation of hazard switch.

When hazard switch is in ON position : HAZARD SW ON

⊗ Without CONSULT-III

Check voltage between BCM harness connector and ground.

Terminal (+)		Terminal (-)	Condition	Voltage
BCM connector	Terminal			
M18	29	Ground	Hazard switch is ON	0V
			Hazard switch is OFF	Battery voltage

OK or NG

- OK >> Replace BCM. Refer to [BCS-21, "Removal and Installation of BCM"](#).
- NG >> GO TO 2.

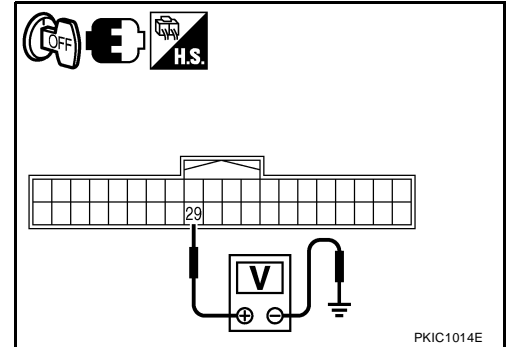

2. CHECK HAZARD SWITCH CIRCUIT

1. Turn ignition switch OFF.
2. Disconnect BCM connector and hazard switch connector.
3. Check continuity between BCM harness connector M18 (A) and hazard switch harness connector M102 (B).

A		B		Continuity
Connector	Terminal	Connector	Terminal	
M18	29	M102	2	Yes

OK or NG

- OK >> GO TO 3.
- NG >> Repair harness or connector.

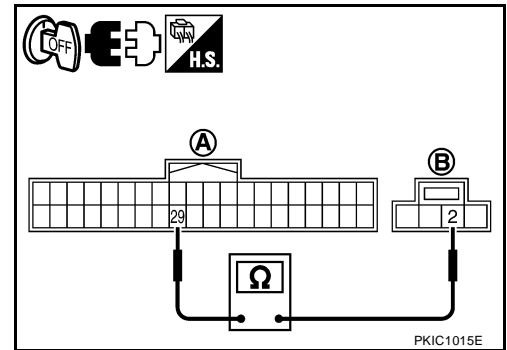

3. CHECK GROUND CIRCUIT

Check continuity between hazard switch harness connector M102 terminal 1 and ground.

1 – Ground : Continuity should exist.

OK or NG

- OK >> GO TO 4.
- NG >> Repair harness or connector.

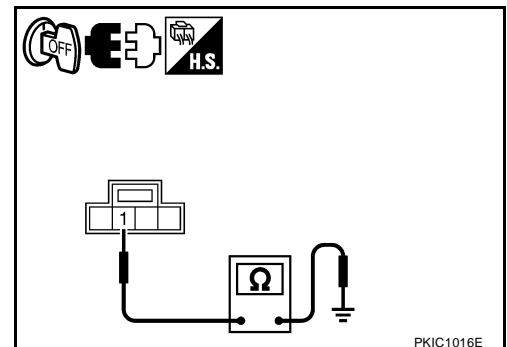

TURN SIGNAL AND HAZARD WARNING LAMPS

4. CHECK HAZARD SWITCH

1. Disconnect hazard switch connector.
2. Check continuity between hazard switch terminals.

Terminal		Condition	Continuity
Hazard switch			
1	2	Hazard switch is ON	Yes
		Hazard switch is OFF	No

OK or NG

OK >> Replace BCM if hazard warning lamps do not operate after setting the connector again. Refer to [BCS-21, "Removal and Installation of BCM"](#) .

NG >> Replace hazard switch. Refer to [LT-63, "Removal and Installation"](#) .

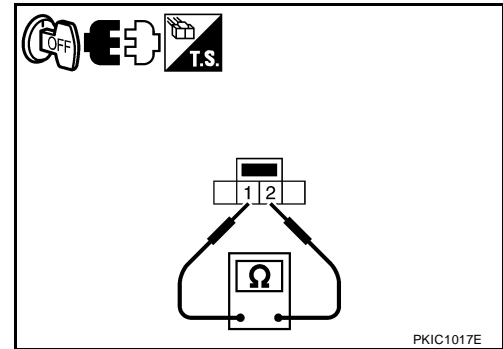

Turn Signal Indicator Lamp Does Not Operate

EKS00J04

1. CHECK CAN COMMUNICATION SYSTEM

Check CAN communication. Refer to [LAN-23, "TROUBLE DIAGNOSIS"](#) .

OK or NG

OK >> Replace combination meter. Refer to [DI-24, "Removal and Installation"](#) .

NG >> Repair as necessary.

TURN SIGNAL AND HAZARD WARNING LAMPS

Bulb Replacement of Front Turn Signal Lamp

EKS00J05

Refer to [LT-61, "Bulb Replacement of Front Turn Signal Lamp"](#) .

A

Bulb Replacement of Rear Turn Signal Lamp

EKS00J06

Refer to [LT-61, "Bulb Replacement of Rear Turn Signal Lamp"](#) .

B

Removal and Installation of Front Turn Signal Lamp

EKS00J07

Refer to [LT-61, "Bulb Replacement of Front Turn Signal Lamp"](#) .

C

Removal and Installation of Rear Turn Signal Lamp

EKS00J08

Refer to [LT-61, "Removal and Installation of Rear Turn Signal Lamp"](#) .

D

E

F

G

H

I

J

LT

L

M

LIGHTING AND TURN SIGNAL SWITCH

LIGHTING AND TURN SIGNAL SWITCH

PF2:25540

Removal and Installation

EKS00J09

REMOVAL

1. Remove steering column cover. Refer to [IP-10, "INSTRUMENT PANEL ASSEMBLY"](#) .
2. While pressing pawls (A) in direction as shown, pull lighting and turn signal switch (1) toward LH door and disconnect from the base.

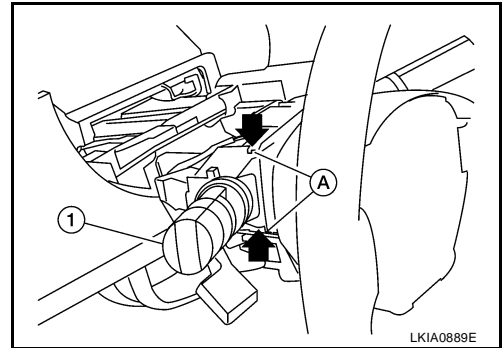

INSTALLATION

Installation is in the reverse order of removal.

HAZARD SWITCH

HAZARD SWITCH

PFP:25290

Removal and Installation

EKS00J0A

REMOVAL

The hazard switch is part of the MT/CVT finisher and replaced as an assembly. Refer to [IP-10, "Component Parts"](#).

INSTALLATION

Installation is in the reverse order of removal.

A

B

C

D

E

F

G

H

I

J

LT

L

M

COMBINATION SWITCH

PF:25567

EKS00JOB

COMBINATION SWITCH

Wiring Diagram — COMBSW —

LT-COMBSW-01

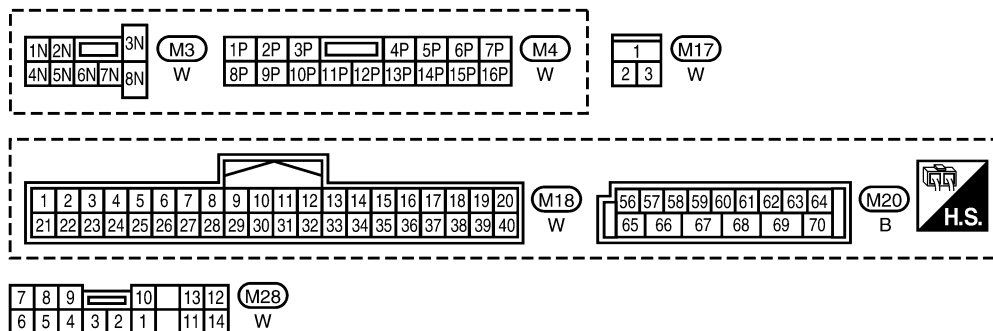
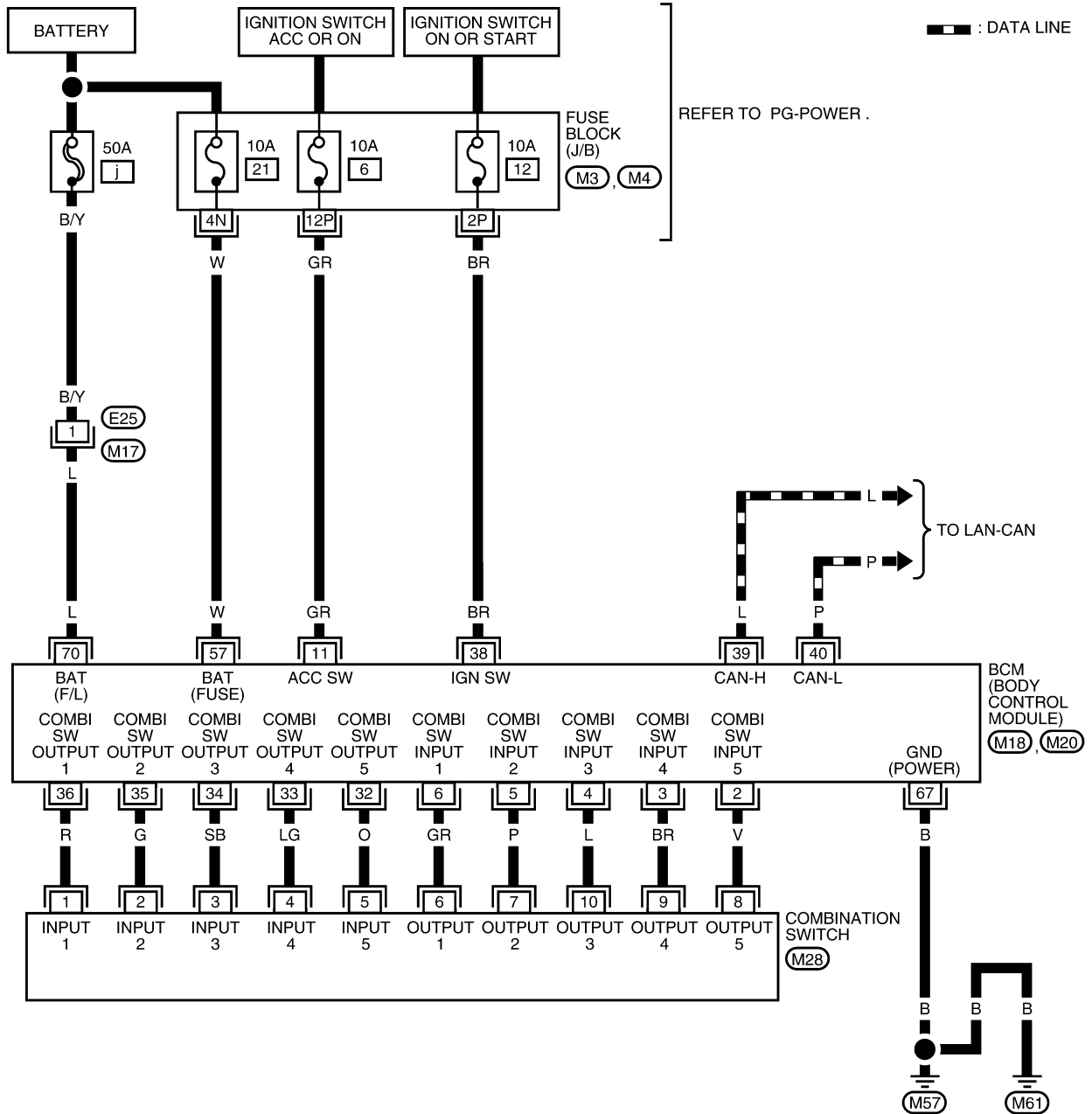

BKWA0796E

COMBINATION SWITCH

Combination Switch Reading Function

EKS00JOC

For details, refer to [LT-65, "Combination Switch Reading Function"](#) .

Terminals and Reference Values for BCM

EKS00JOD

Refer to [BCS-13, "Terminals and Reference Values for BCM"](#) .

CONSULT-III Function (BCM)

EKS00JOE

Refer to [BCS-18, "CONSULT-III Function \(BCM\)"](#) .

Combination Switch Inspection

EKS00JOF

1. SYSTEM CHECK

Referring to table below, check which system malfunctioning switch belongs to.

System 1	System 2	System 3	System 4	System 5
—	FRONT WASHER	FRONT WIPER LO	TURN LH	TURN RH
FRONT WIPER HI	—	FRONT WIPER INT	PASSING	HEAD LAMP 1
INT VOLUME 1	—	—	HEAD LAMP 2	HI BEAM
—	INT VOLUME 3	—	—	LIGHT SW 1ST
INT VOLUME 2	—	—	FRONT FOG	—

>> Check the system to which the switch belongs, and GO TO 2.

2. SYSTEM CHECK

With CONSULT-III

1. Connect CONSULT-III, and select "COMB SW" on BCM "SELECT TEST ITEM" screen.
2. Select "DATA MONITOR".
3. Select "START", and confirm that other switches in the system operate normally.
Example: When turn signal LH is inoperative, confirm that PASSING, HEAD LAMP 2 or FRONT FOG (if equipped) turn ON-OFF normally.

Without CONSULT-III

Operate combination switch, and confirm that other switches in the system operate normally.
Example: When a turn signal switch is inoperative, confirm that FRONT WIPER LO or FRONT WIPER INT turn ON-OFF normally.

Check results

Other switches in the system operate normally.>>Replace lighting switch or wiper switch.

Other switches in the system do not operate normally.>>GO TO 3.

COMBINATION SWITCH

3. HARNESS INSPECTION

1. Turn ignition switch OFF.
2. Disconnect BCM connector and combination switch connector.
3. Check for continuity between BCM harness connector of the suspect system and the corresponding combination switch harness connector.

Suspect system	A		B		Continuity	
	Connector	Terminal	Connector	Terminal		
1	M18	Input 1	6	M28	6	Yes
		Output 1	36		1	
2		Input 2	5		7	
		Output 2	35		2	
3		Input 3	4		10	
		Output 3	34		3	
4		Input 4	3		9	
		Output 4	33		4	
5		Input 5	2		8	
		Output 5	32		5	

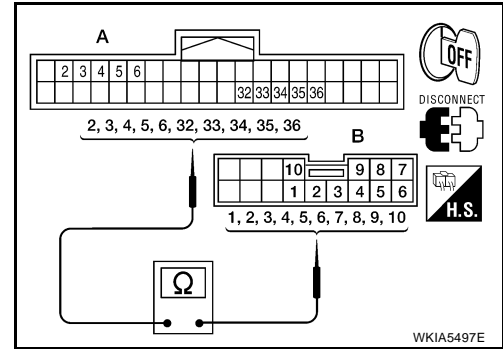

4. Check for continuity between the BCM harness connector in suspect system and ground.

Suspect system	BCM		Continuity		
	Connector	Terminal			
1	M18	Input 1	6	Ground	No
		Output 1	36		
2		Input 2	5		
		Output 2	35		
3		Input 3	4		
		Output 3	34		
4		Input 4	3		
		Output 4	33		
5		Input 5	2		
		Output 5	32		

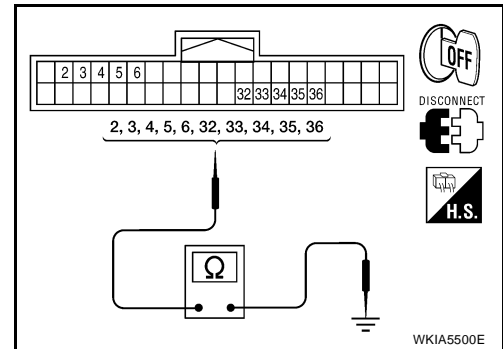

OK or NG

- OK >> GO TO 4.
 NG >> Check harness between BCM and combination switch for open or short circuit.

COMBINATION SWITCH

4. CHECK BCM OUTPUT TERMINAL

1. Connect BCM and combination switch connectors.
2. Turn ignition switch ON.
3. Turn lighting switch and wiper switch to OFF position.
4. Set wiper dial to position 4.
5. Check BCM output terminal voltage waveform of suspect system.

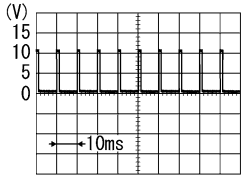
Suspect system	Terminal (+)		Terminal (-)	Reference value
	Combination switch connector	Terminal		
1	M28	1	Ground	 1.2V
2		2		
3		3		
4		4		
5		5		

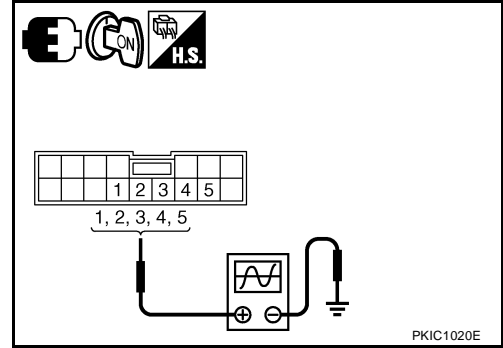

OK or NG

OK >> Open circuit in combination switch, GO TO 5.

NG >> Replace BCM. Refer to [BCS-21, "Removal and Installation of BCM"](#).

5. COMBINATION SWITCH INSPECTION

Referring to table below, perform combination switch inspection.

Procedure									
1	2		3	4		5	6		7
Replace lighting switch	Confirm check results	OK	INSPECTION END	Confirm check results	OK	INSPECTION END	Confirm check results	OK	INSPECTION END
		NG	Replace wiper switch		NG	Replace switch base		NG	Confirm symptom again

>> Inspection end.

Removal and Installation

Refer to [LT-64, "COMBINATION SWITCH"](#).

EKS00JOG

STOP LAMP

PFP:26550

STOP LAMP

Wiring Diagram — STOP/L —

EKS00J0H

LT-STOP/L-01

- ⬡ M : WITH MT
- ⬡ OS : WITHOUT REAR SPOILER
- ⬡ SP : WITH REAR SPOILER
- ⬡ VT : WITH CVT

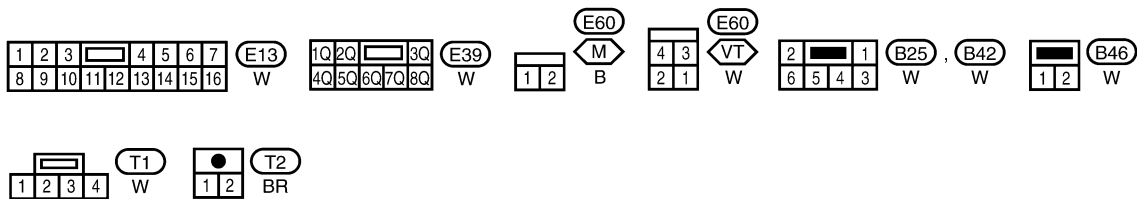
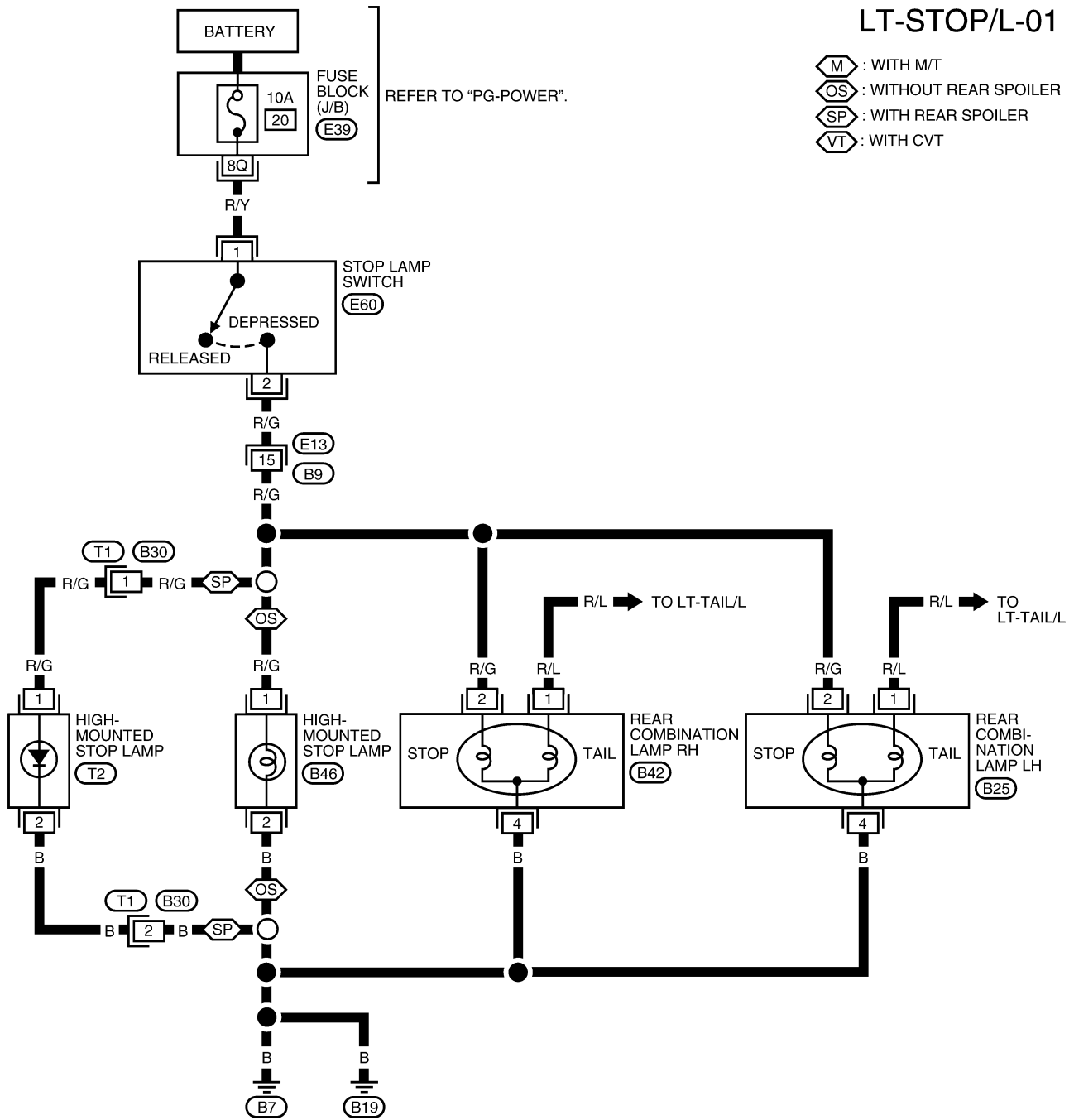

BKWA0838E

STOP LAMP

Bulb Replacement of High-Mounted Stop Lamp

EKS00JOI

Refer to [LT-69, "Bulb Replacement of High-Mounted Stop Lamp"](#) .

Bulb Replacement of Rear Combination Lamp for Stop Lamp

EKS00JOK

Refer to [LT-86, "Bulb Replacement"](#) .

Removal and Installation of High-Mounted Stop Lamp, All Except SE-R

EKS00JOK

1. Unclip to release the rear high-mount stop lamp (1) from the rear parcel shelf finisher (2) and remove the rear high-mount stop lamp (1).
2. Disconnect the rear high-mounted stop lamp connector, turn the bulb socket counterclockwise and remove the high-mounted stop lamp bulb.

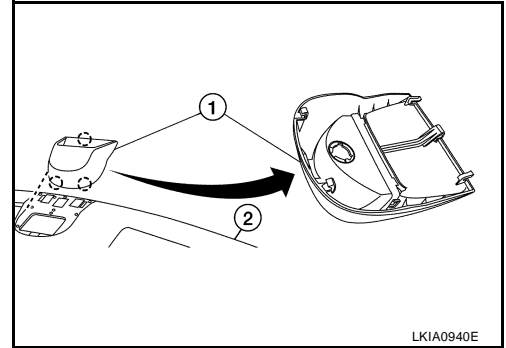

INSTALLATION

Installation is in the reverse order of removal.

Removal and Installation of High-Mounted Stop Lamp, SE-R

EKS00L4Z

1. Remove the trunk lid finisher. Refer to [EI-42, "Removal and Installation"](#) .
2. Remove the led high-mounted stop lamp screws (A), then remove the led high-mounted stop lamp assembly (2).
 - Rear air spoiler (1)

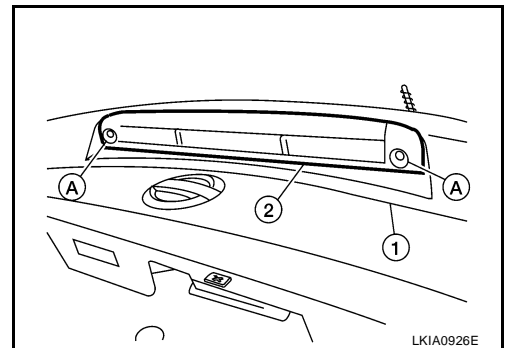

INSTALLATION

Installation is in the reverse order of removal.

Removal and Installation of Rear Combination Lamp for Stop Lamp

EKS00JOL

Refer to [LT-86, "Removal and Installation"](#) .

BACK-UP LAMP

PF2:26550

BACK-UP LAMP

Wiring Diagram — BACK/L —

EKS00J0M

LT-BACK/L-01

⬡M : WITH M/T
⬡VT : WITH CVT

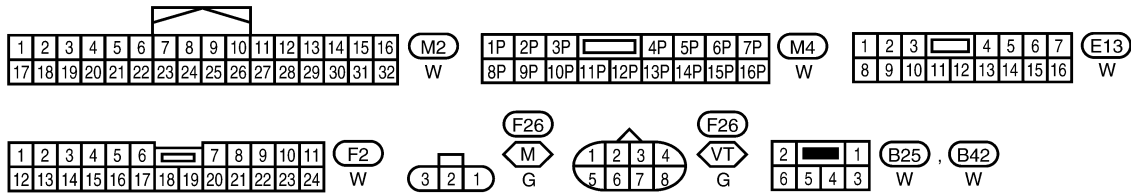
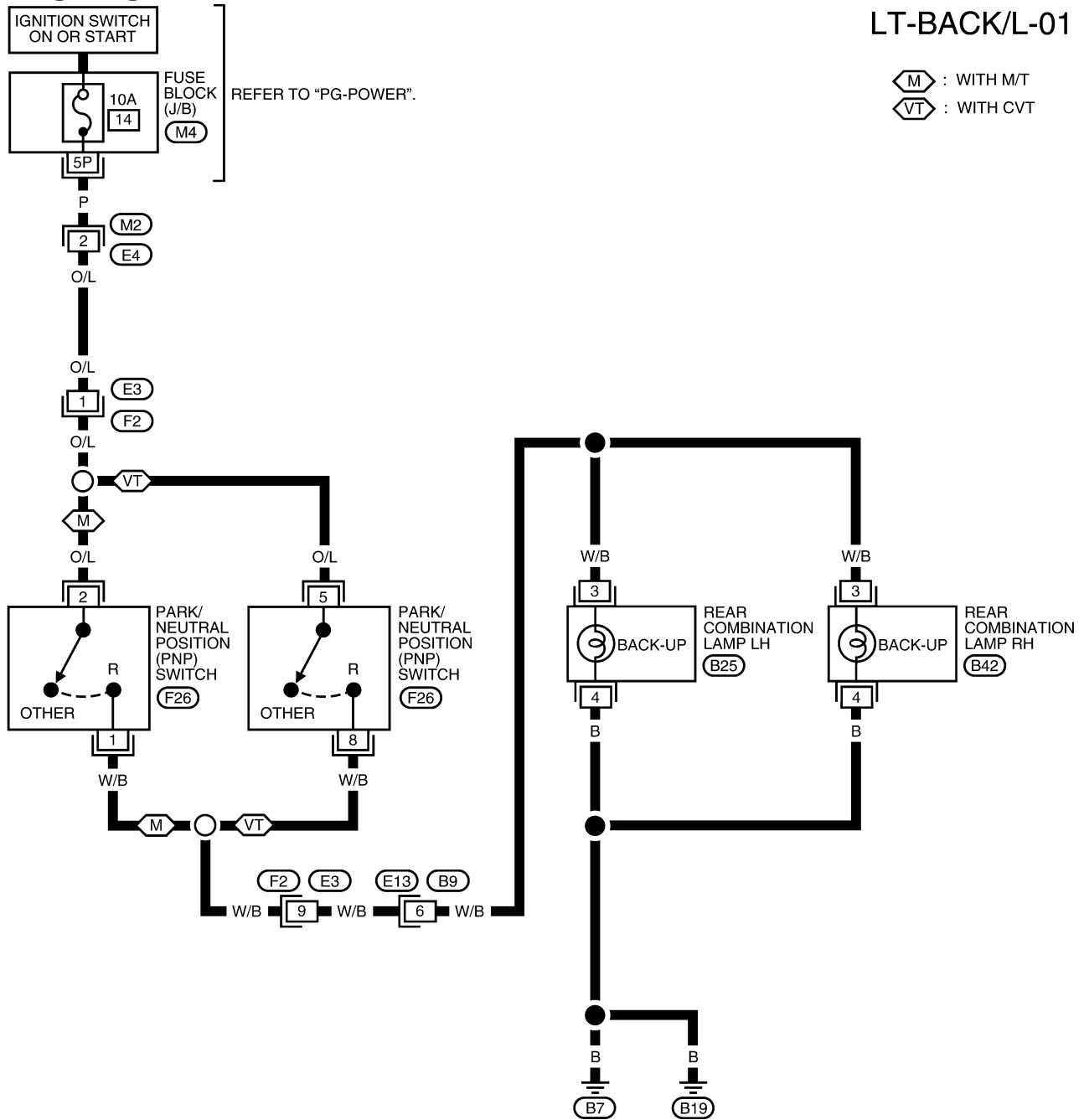

BKWA0798E

BACK-UP LAMP

Bulb Replacement

EKS00J0N

Refer to [LT-71, "Bulb Replacement"](#) .

A

Removal and Installation

EKS00J0O

Refer to [LT-71, "Removal and Installation"](#) .

B

C

D

E

F

G

H

I

J

LT

L

M

PARKING, LICENSE PLATE AND TAIL LAMPS

PF2:26550

Component Parts and Harness Connector Location

EKS00J0P

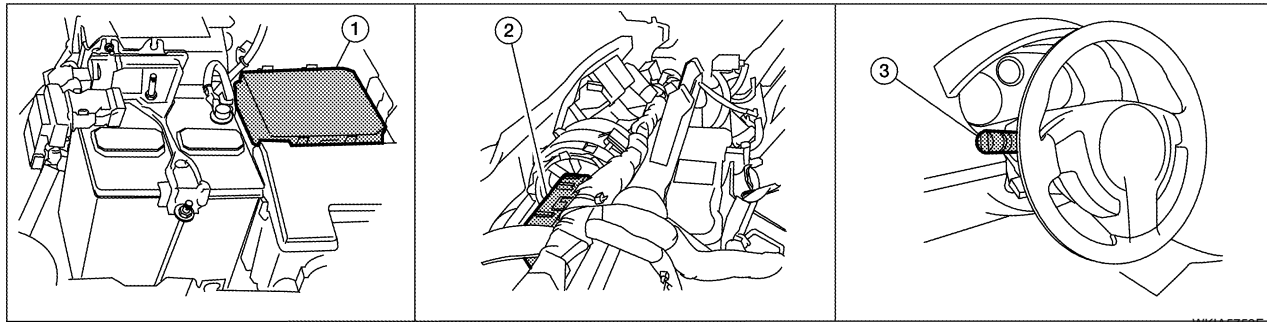

1. IPDM E/R E45, E46 and E48

2. BCM M18 and M20 (view with instrument panel removed)

3. Combination switch (lighting switch) M28

System Description

EKS00J0Q

The control of the parking, license plate and tail lamp operation is dependent upon the position of lighting switch. When the lighting switch is placed in the 1ST position, the BCM (body control module) receives input signal requesting the parking, license plate and tail lamps to illuminate. This input signal is communicated to the IPDM E/R (intelligent power distribution module engine room) via the CAN communication lines. The CPU (central processing unit) located in the IPDM E/R controls the tail lamp relay coil. This relay, when energized, directs power to parking, license plate and tail lamps, which then illuminate. Power is supplied at all times

- to ignition relay located in IPDM E/R,
- to tail lamp relay located in IPDM E/R,
- through 15A fuse (No. 52, located in IPDM E/R) and
- through 20A fuse (No. 53, located in IPDM E/R)
- to the CPU located in the IPDM E/R,
- through 50A fusible link (letter j , located in fuse and fusible link block)
- to BCM terminal 70,
- through 10A fuse [No. 21, located in fuse block (J/B)],
- to BCM terminal 57.

With the ignition switch in the ON or START position, power is supplied

- through 10A fuse [No. 12, located in fuse block (J/B)]
- to BCM terminal 38,
- to ignition relay located in IPDM E/R and
- through the ignition relay
- to the CPU of the IPDM E/R.

With the ignition switch in the ACC or ON position, power is supplied

- through 10A fuse [No. 6, located in fuse block (J/B)]
- to BCM terminal 11.

Ground is supplied

- to BCM terminal 67
- through grounds M57 and M61,
- to IPDM E/R terminals 59 and 39
- through grounds E9, E15 (all models) and E24 (with MR20DE).

OPERATION BY LIGHTING SWITCH

With the lighting switch in the 1ST or 2ND position, the BCM receives an input signal requesting parking, license plate and tail lamps to illuminate. This input signal is communicated to the IPDM E/R via the CAN communication lines. The CPU, located in the IPDM E/R, controls the tail lamp relay coil. When energized, the tail lamp relay directs power

PARKING, LICENSE PLATE AND TAIL LAMPS

- through 10A fuse (No. 37, located in IPDM E/R),
- through IPDM E/R terminal 28
- to front combination lamp LH terminal 1, and
- through IPDM E/R terminal 29
- to front combination lamp RH terminal 1,
- through 10A fuse (No. 36, located in IPDM E/R)
- through IPDM E/R terminal 27
- to rear combination lamp LH and RH terminal 1 and
- to license plate lamp LH and RH terminal 1.

Ground is supplied

- to front combination lamp LH and RH terminal 2
- through grounds E9, E15 (all models) and E24 (with MR20DE),
- to rear combination lamp LH and RH terminal 4 and
- to license plate lamp LH and RH terminal 2
- through grounds B7 and B19.

With power and ground supplied, parking, license plate and tail lamps illuminate.

COMBINATION SWITCH READING FUNCTION

Refer to [LT-65, "Combination Switch Reading Function"](#) .

EXTERIOR LAMP BATTERY SAVER CONTROL

When the combination switch (lighting switch) is in the 1ST (or 2ND) position and the ignition switch is turned from ON or ACC to OFF, the battery saver control feature is activated.

Under this condition, the parking, license and tail lamps remain illuminated for 5 minutes, then the parking, license plate and tail lamps are turned off.

Exterior lamp battery saver control mode can be changed by the function setting of CONSULT-III.

CAN Communication System Description

EKS00J0R

Refer to [LAN-4, "SYSTEM DESCRIPTION"](#) .

A

B

C

D

E

F

G

H

I

J

LT

L

M

PARKING, LICENSE PLATE AND TAIL LAMPS

Schematic

EKS00J0S

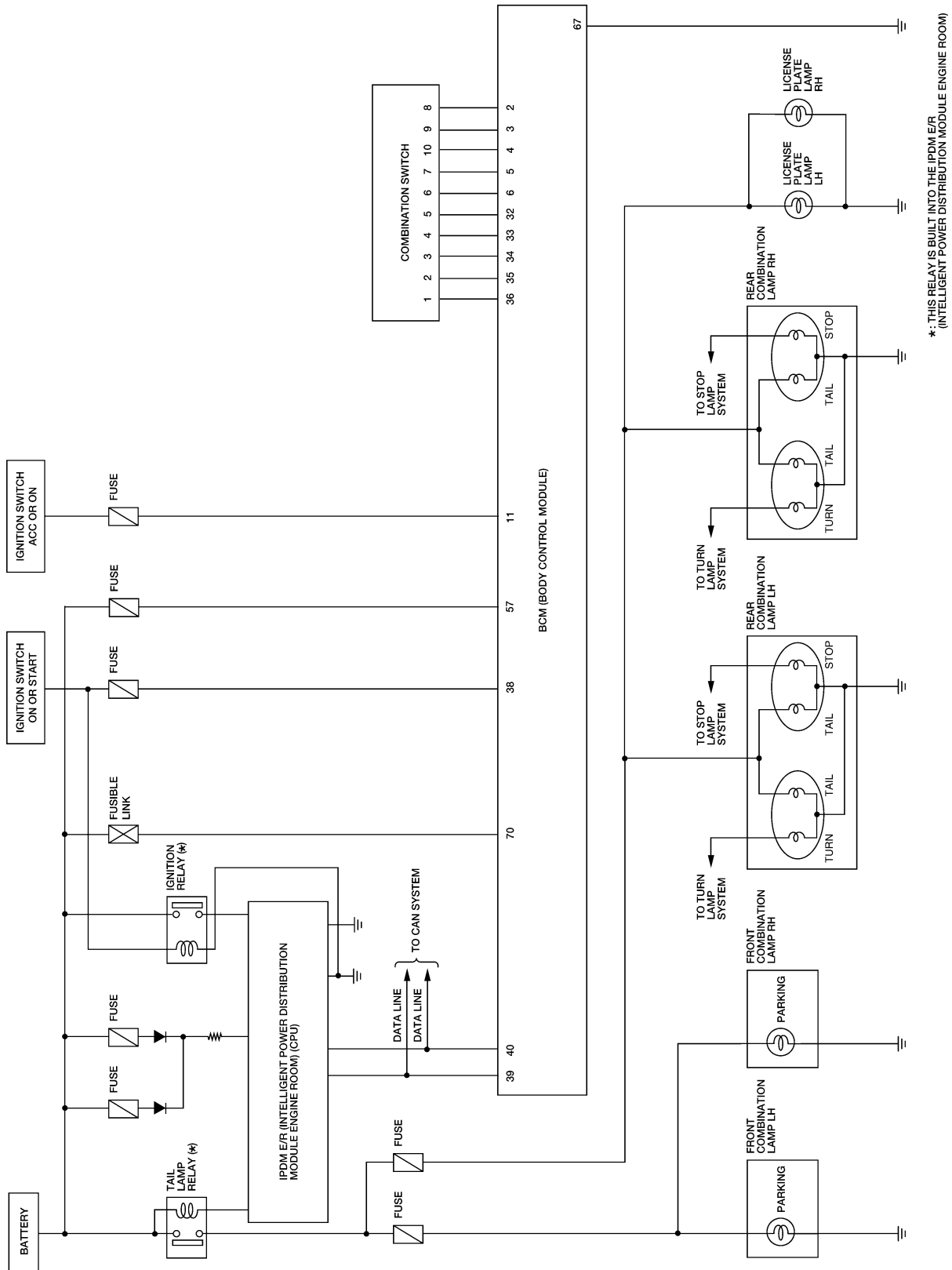

BKWA0799E

PARKING, LICENSE PLATE AND TAIL LAMPS

Wiring Diagram — TAIL/L —

EKS00JOT

LT-TAIL/L-01

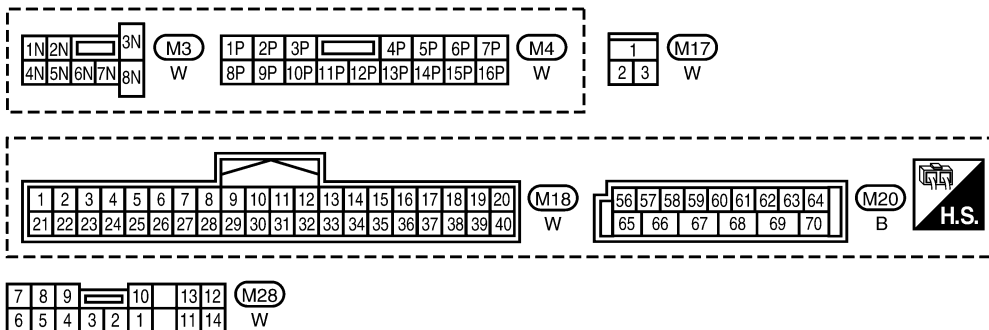
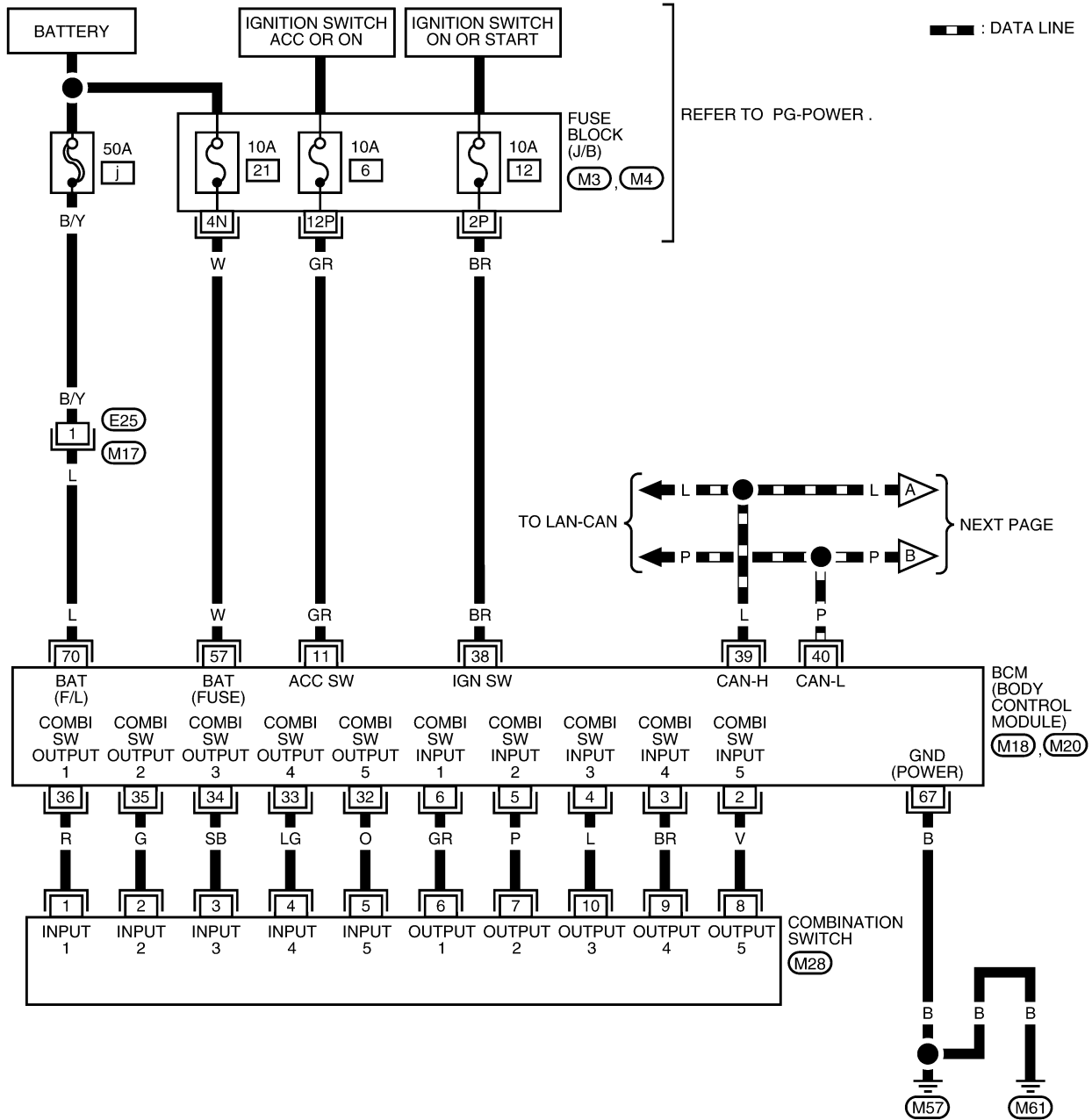

PARKING, LICENSE PLATE AND TAIL LAMPS

LT-TAIL/L-02

▬ : DATA LINE

MR : WITH MR20DE

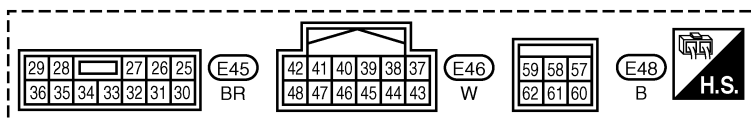
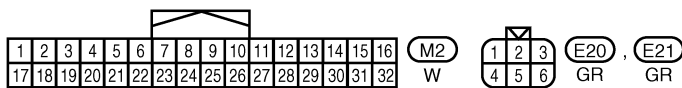
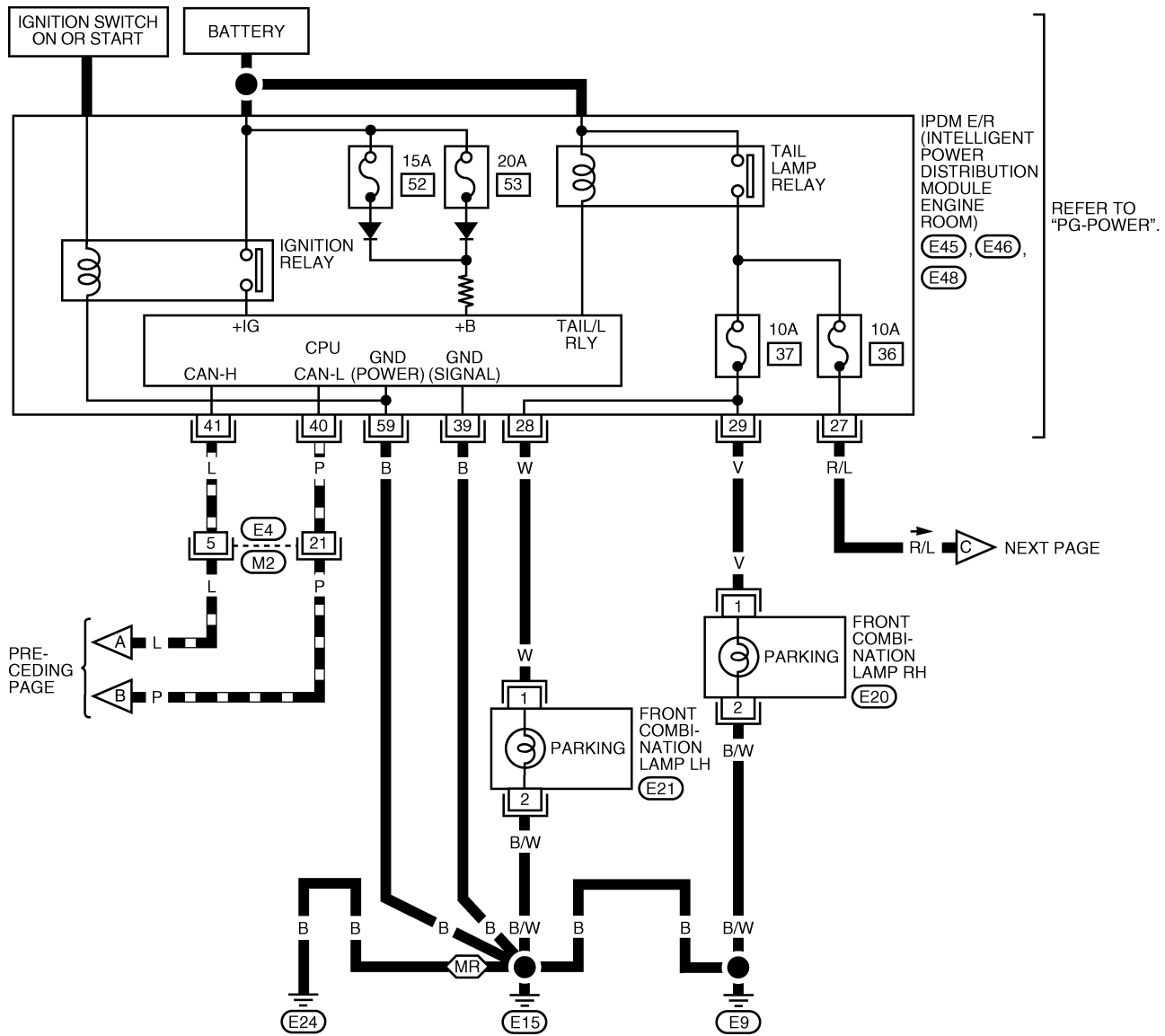

BKWA0839E

PARKING, LICENSE PLATE AND TAIL LAMPS

PRECEDING PAGE ◀ C ▶ R/L

LT-TAIL/L-03

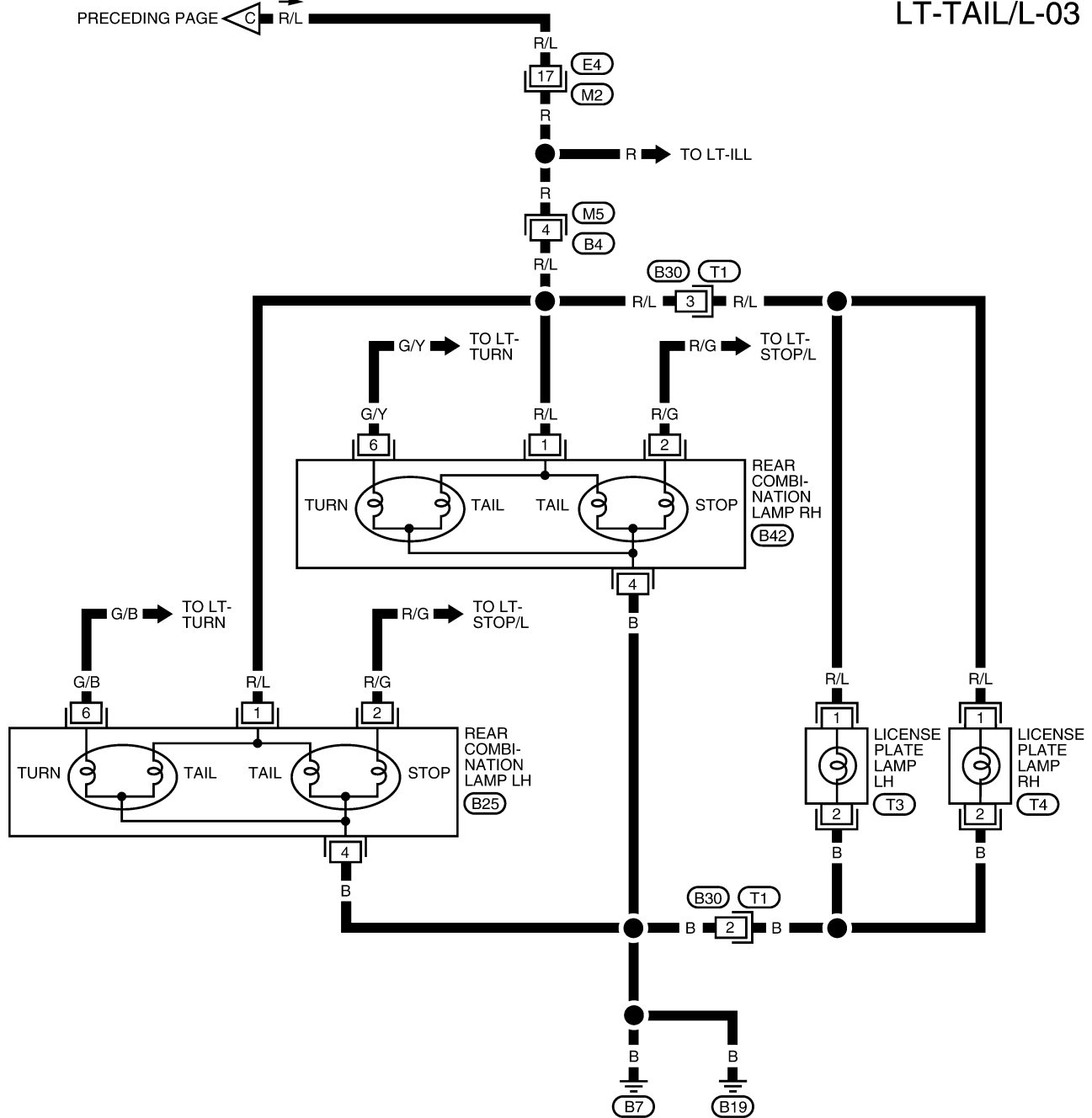

A
B
C
D
E
F
G
H
I
J
LT
L
M

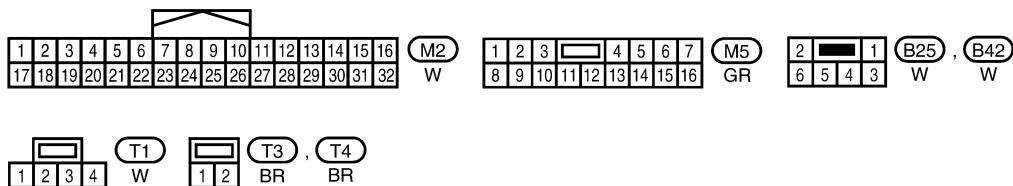

BKWA0802E

PARKING, LICENSE PLATE AND TAIL LAMPS

Terminals and Reference Values for BCM

EKS00J0U

Refer to [BCS-13, "Terminals and Reference Values for BCM"](#) .

Terminals and Reference Values for IPDM E/R

EKS00J0V

Refer to [PG-26, "Terminals and Reference Values for IPDM E/R"](#) .

How to Proceed With Trouble Diagnosis

EKS00J0W

1. Confirm the symptom or customer complaint.
2. Understand operation description and function description. Refer to [LT-72, "System Description"](#) .
3. Perform the preliminary check. Refer to [LT-78, "Preliminary Check"](#) .
4. Check symptom and repair or replace the cause of the malfunction.
5. Do the parking, license plate and tail lamps operate normally? If YES, GO TO 6. If NO, GO TO 4.
6. Inspection End.

Preliminary Check

EKS00J0X

CHECK POWER SUPPLY AND GROUND CIRCUIT FOR BCM

Refer to [BCS-16, "BCM Power Supply and Ground Circuit Check"](#) .

CHECK POWER SUPPLY AND GROUND CIRCUIT FOR IPDM E/R

Refer to [PG-29, "IPDM E/R Power/Ground Circuit Inspection"](#) .

CONSULT-III Function (BCM)

EKS00J0Y

Refer to [BCS-18, "CONSULT-III Function \(BCM\)"](#) .

CONSULT-III Function (IPDM E/R)

EKS00J0Z

Refer to [PG-20, "CONSULT-III Function \(IPDM E/R\)"](#) .

Parking, License Plate and Tail Lamps Do Not Illuminate

EKS00JP0

1. CHECK TAIL LAMP FUSE

Inspect tail lamp 10A fuses (No. 36 and 37, located in IPDM E/R).

OK or NG

- OK >> GO TO 2.
NG >> Repair harness.

2. CHECK COMBINATION SWITCH INPUT SIGNAL

With CONSULT-III

1. Select "BCM" on CONSULT-III. Select "HEAD LAMP" on "SELECT TEST ITEM" screen.
2. Select "DATA MONITOR". Make sure "LIGHT SW 1ST" turns ON-OFF linked with operation of lighting switch.

When lighting switch is 1ST : LIGHT SW 1ST ON position

Without CONSULT-III

Refer to [LT-65, "Combination Switch Inspection"](#) .

OK or NG

- OK >> GO TO 3.
NG >> Check combination switch (lighting switch). Refer to [LT-65, "Combination Switch Inspection"](#) .

PARKING, LICENSE PLATE AND TAIL LAMPS

3. ACTIVE TEST

With CONSULT-III

1. Select "IPDM E/R" on CONSULT-III, and select "ACTIVE TEST".
2. Select "TAIL LAMP" on "SELECT TEST ITEM" screen.
3. Touch "ON" on "ACTIVE TEST" screen.
4. Make sure parking, license plate and tail lamps operate.

Parking, license plate and tail lamps should operate.

Without CONSULT-III

1. Start auto active test. Refer to [PG-22, "Auto Active Test"](#) .
2. Make sure parking, license plate and tail lamps operate.

Parking, license plate and tail lamps should operate.

OK or NG

OK >> GO TO 4.

NG >> Replace the IPDM E/R if the parking, license and tail lamps do not start operating after resetting connector. Refer to [PG-30, "Removal and Installation of IPDM E/R"](#) .

4. CHECK IPDM E/R

1. Select "IPDM E/R" on CONSULT-III, and select "DATA MONITOR".
2. Make sure "TAIL&CLR REQ" turns ON when lighting switch is in 1ST position.

When lighting switch is 1ST : TAIL&CLR REQ ON position

OK or NG

OK >> Replace IPDM E/R. Refer to [PG-30, "Removal and Installation of IPDM E/R"](#) .

NG >> Replace BCM. Refer to [BCS-21, "Removal and Installation of BCM"](#) .

Front Parking Lamps Do Not Illuminate (License Plate and Tail Lamps Operate Normally)

EKS00JP0

1. CHECK FUSE

Inspect parking lamp 10A fuse (No. 37, located in IPDM E/R)

OK or NG

OK >> GO TO 2.

NG >> Repair harness.

PARKING, LICENSE PLATE AND TAIL LAMPS

2. CHECK INPUT SIGNAL

Ⓟ With CONSULT-III

1. Turn ignition switch OFF.
2. Disconnect front combination lamp connectors.
3. Turn ignition switch ON.
4. Select "IPDM E/R" on CONSULT-III, and select "ACTIVE TEST".
5. Select "TAIL LAMP" on "SELECT TEST ITEM" screen.
6. Touch "ON" on "ACTIVE TEST" screen.
7. When tail lamp relay is operating, check voltage between front combination lamp and ground.

Ⓟ Without CONSULT-III

1. Turn ignition switch OFF.
2. Disconnect front combination lamp connectors.
3. Turn ignition switch ON.
4. Start auto active test. Refer to [PG-22, "Auto Active Test"](#) .
5. When tail lamp relay is operating, check voltage between front combination lamp and ground.

Terminal (+)		Terminal (-)	Voltage
Front combination lamp connector	Terminal		
RH	E20	1	Ground
LH	E21		
			Battery voltage

OK or NG

- OK >> GO TO 4.
 NG >> GO TO 3.

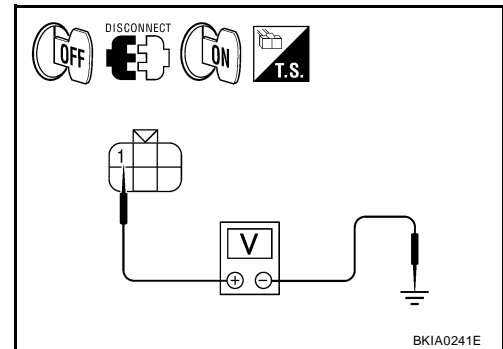

3. CHECK PARKING LAMP CIRCUIT

1. Turn ignition switch OFF.
2. Disconnect IPDM E/R connector.
3. Check continuity between IPDM E/R harness connector (A) and front combination lamp harness connector (B).

A		B		Continuity
Connector	Terminal	Connector	Terminal	
E45	29	RH	E20	Yes
	28	LH	E21	

OK or NG

- OK >> Replace IPDM E/R. Refer to [PG-30, "Removal and Installation of IPDM E/R"](#) .
 NG >> Repair harness or connector.

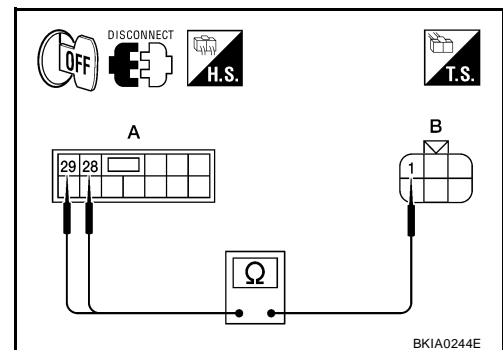

PARKING, LICENSE PLATE AND TAIL LAMPS

4. CHECK PARKING LAMPS GROUND CIRCUIT

Check continuity between front combination lamp harness connector and ground.

Front combination lamp connector		Terminal	Ground	Continuity
RH	E20	2		Yes
LH	E21			

OK or NG

OK >> Check bulbs.

NG >> Repair harness or connector.

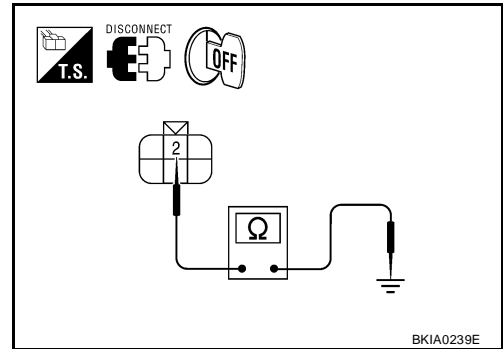

License Plate and Tail Lamps Do Not Illuminate (Front Parking Lamps Operate Normally)

EKS00JP0

1. CHECK FUSE

Inspect tail lamp 10A fuse (No. 36, located in IPDM E/R)

OK or NG

OK >> GO TO 2.

NG >> Repair harness.

A
B
C
D
E
F
G
H
I
J
LT
L
M

PARKING, LICENSE PLATE AND TAIL LAMPS

2. CHECK INPUT SIGNAL

Ⓜ With CONSULT-III

1. Turn ignition switch OFF.
2. Disconnect license plate lamp and rear combination lamp connectors.
3. Turn ignition switch ON.
4. Select "IPDM E/R" on CONSULT-III, and select "ACTIVE TEST".
5. Select "TAIL LAMP" on "SELECT TEST ITEM" screen.
6. Touch "ON" on "ACTIVE TEST" screen.
7. When tail lamp relay is operating, check voltage between license plate lamp and rear combination lamp harness connectors and ground.

Ⓜ Without CONSULT-III

1. Turn ignition switch OFF.
2. Disconnect license plate lamp and rear combination lamp connectors.
3. Turn ignition switch ON.
4. Start auto active test. Refer to [PG-22, "Auto Active Test"](#).
5. When tail lamp relay is operating, check voltage between license plate lamp and rear combination lamp harness connectors and ground.

Terminal		Terminal	(-)	Voltage
(+)				
License plate lamp connector		1	Ground	Battery voltage
RH	T4			
LH	T3			

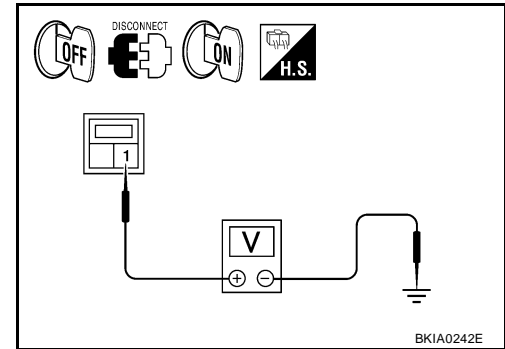

Terminal		Terminal	(-)	Voltage
(+)				
Rear combination lamp connector (Tail lamp)		1	Ground	Battery voltage
RH	B42			
LH	B25			

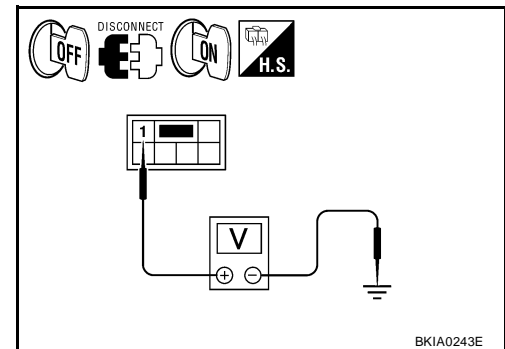

OK or NG

- OK >> GO TO 4.
 NG >> GO TO 3.

PARKING, LICENSE PLATE AND TAIL LAMPS

3. CHECK LICENSE PLATE AND TAIL LAMP CIRCUIT

1. Turn ignition switch OFF.
2. Disconnect IPDM E/R connector.
3. Check continuity between IPDM E/R harness connector (A) and license plate lamp harness connector (B).

A		B		Continuity
Connector	Terminal	Connector	Terminal	
E45	27	RH	T4	Yes
		LH	T3	

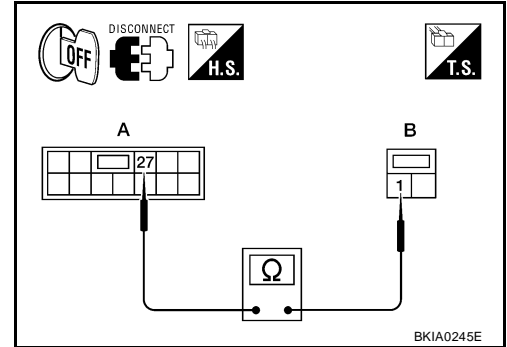

4. Check continuity between IPDM E/R harness connector (A) and rear combination lamp harness connector (B).

A		B		Continuity
Connector	Terminal	Connector	Terminal	
E45	27	RH	B42	Yes
		LH	B25	

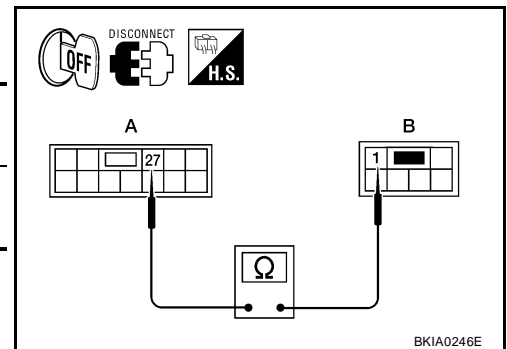

OK or NG

OK >> Replace IPDM E/R. Refer to [PG-30, "Removal and Installation of IPDM E/R"](#).

NG >> Repair harness or connector.

4. CHECK PARKING, LICENSE PLATE AND TAIL LAMPS GROUND CIRCUIT

1. Check continuity between license plate lamp harness connector and ground.

License plate lamp connector		Terminal	Ground	Continuity
RH	T4	2		Yes
LH	T3			

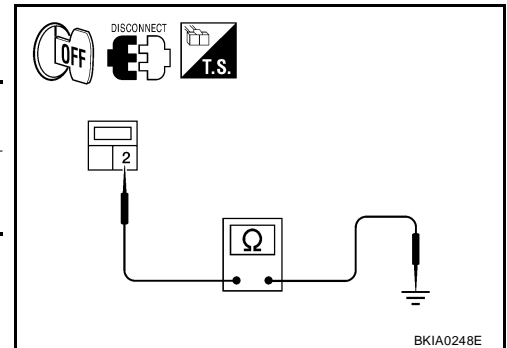

2. Check continuity between rear combination lamp harness connector and ground.

Rear combination lamp connector		Terminal	Ground	Continuity
RH	B42	T4		Yes
LH	B25			

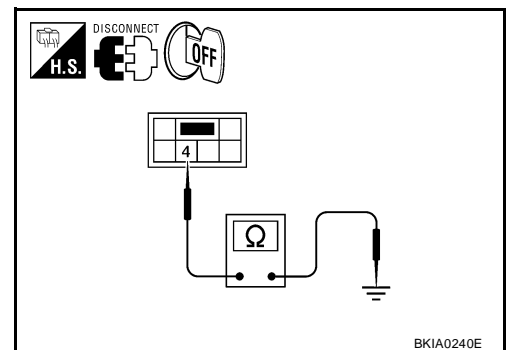

OK or NG

OK >> Check bulbs.

NG >> Repair harness or connector.

PARKING, LICENSE PLATE AND TAIL LAMPS

Parking, License Plate and Tail Lamps Do Not Turn OFF (After Approx. 10 Minutes)

EKS00JP1

- This symptom is related to the ignition relay in IPDM E/R. Refer to [PG-19, "Function of Detecting Ignition Relay Malfunction"](#) .
- Select "BCM" on CONSULT-III. Select "HEAD LAMP" on "SELECT TEST ITEM" screen and select "DATA MONITOR". If "LIGHT SW 1ST" is OFF when lighting switch is OFF, replace IPDM E/R.

PARKING, LICENSE PLATE AND TAIL LAMPS

Bulb Replacement

EKS00JP2

PARKING LAMP

Refer to [LT-85, "Bulb Replacement"](#) .

LICENSE PLATE LAMP

1. Remove the license plate lamp. Refer to [LT-85, "Removal and Installation"](#) .
2. Turn bulb socket counterclockwise and unlock it.
3. Remove bulb from the socket.
4. Installation is in the reverse order of removal.

TAIL LAMP

Refer to [LT-85, "Removal and Installation"](#) .

Removal and Installation

EKS00JP3

PARKING LAMP

Refer to [LT-85, "Removal and Installation"](#) .

LICENSE PLATE LAMP

Removal

1. Remove the license lamp finisher. Refer to [EI-24, "LICENSE LAMP FINISHER"](#) .
2. Remove license plate lamp screw (A) and remove the license plate lamp (1).
3. Disconnect the license plate lamp connector and remove the licence plate lamp.

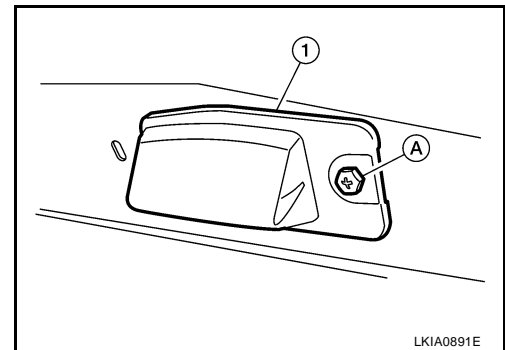

Installation

Installation is in the reverse order of removal.

TAIL LAMP

Refer to [LT-85, "Removal and Installation"](#) .

A

B

C

D

E

F

G

H

I

J

LT

L

M

REAR COMBINATION LAMP

REAR COMBINATION LAMP

PF2:26554

Components

EKS00JP4

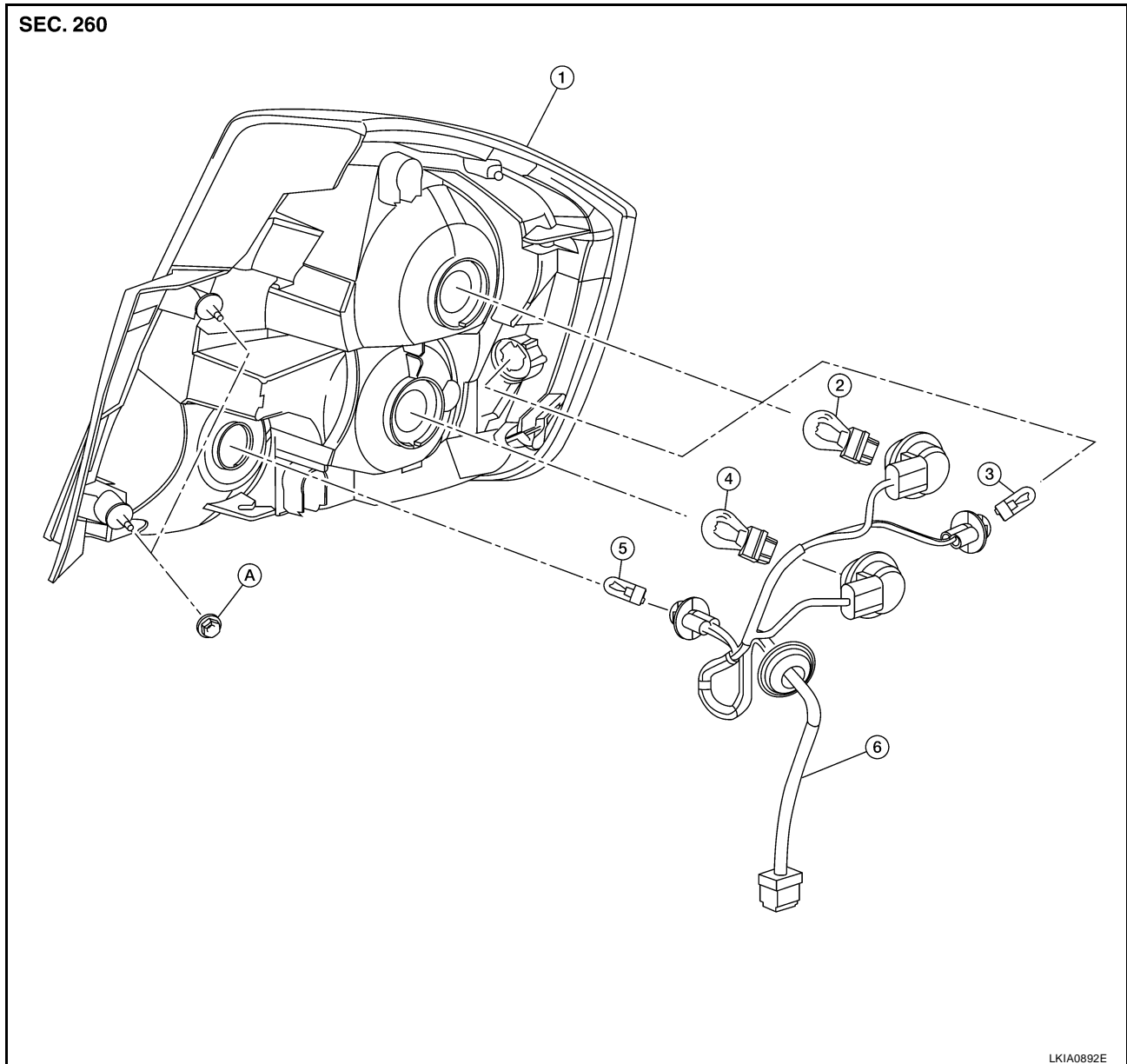

- | | | |
|--|------------------------------|----------------------------------|
| 1. Rear combination lamp housing assembly | 2. Turn signal/run lamp bulb | 3. Rear side marker lamp bulb |
| 4. Run/stop lamp bulb | 5. Back-up lamp bulb | 6. Rear combination lamp harness |
| A. Rear combination lamp housing assembly nuts | | |

Bulb Replacement

EKS00JP5

1. Remove the rear combination lamp. Refer to [LT-86, "Removal and Installation"](#) .
2. Turn bulb socket counterclockwise and unlock it.
3. Remove bulb.
4. Installation is in the reverse order of removal.

Removal and Installation

REMOVAL

EKS00JP6

1. Remove the luggage compartment side finisher. Refer to [EI-42, "TRUNK ROOM TRIM & TRUNK LID FINISHER"](#) .

REAR COMBINATION LAMP

-
2. Detach the harness clips and remove rear combination lamp housing assembly nuts.
 3. Pull the rear combination lamp toward the rear of the vehicle.
 4. Disconnect rear combination lamp connector, and remove rear combination lamp.

A

INSTALLATION

Installation is in the reverse order of removal.

B

Disassembly and Assembly

EKS00JP7

DISASSEMBLY

1. Turn the turn signal/run lamp bulb socket counterclockwise and remove.
2. Turn the rear side marker lamp bulb socket counterclockwise and remove.
3. Turn the rear run/stop lamp bulb socket counterclockwise and remove.
4. Turn the back-up lamp bulb socket counterclockwise and remove.
5. Remove the bulbs from the rear combination lamp harness sockets.

C

D

E

ASSEMBLY

Assembly is in the reverse order of disassembly.

F

G

H

I

J

LT

L

M

INTERIOR LAMP

INTERIOR LAMP

PFP:28491

Map lamp BULB REPLACEMENT

EKS00JP8

1. Remove the map lamp. Refer to [LT-88, "INTERIOR LAMP"](#) .
2. Twist and remove the bulbs (1) from lamp.
3. Installation is in the reverse order of removal.

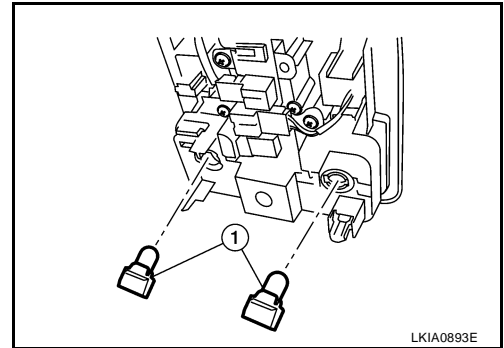

REMOVAL AND INSTALLATION

Removal

1. Remove the map lamp lens.
2. Remove the screw (A) from the map lamp (1).
3. Disconnect map lamp connector and remove map lamp (1).

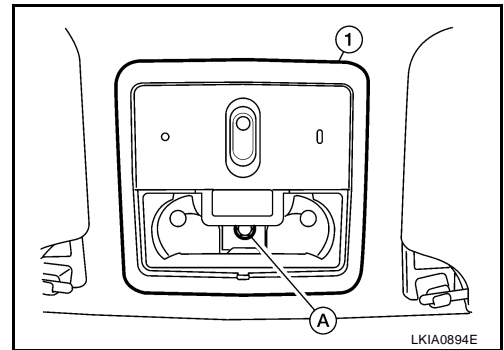

Installation

Installation is in the reverse order of removal.

Luggage Compartment Lamp BULB REPLACEMENT

EKS00JP9

1. Open luggage compartment lamp cover.
2. Remove the bulb.
3. Installation is in the reverse order of removal.

REMOVAL AND INSTALLATION

Removal

1. Open luggage compartment lamp cover.
2. Push the luggage compartment pawl tab (A).
3. Pull the luggage compartment lamp (1) toward the side and down to remove.
4. Disconnect luggage compartment lamp connector.

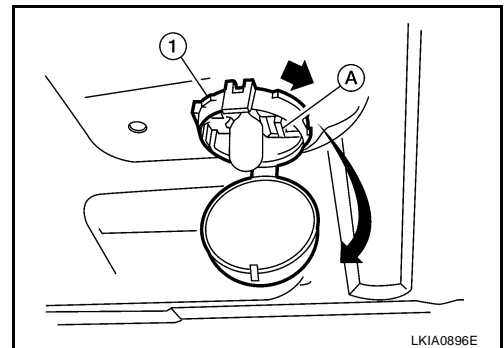

Installation

Installation is in the reverse order of removal.

INTERIOR ROOM LAMP

PFP:26410

EKS00JPA

INTERIOR ROOM LAMP

Component Parts and Harness Connector Location

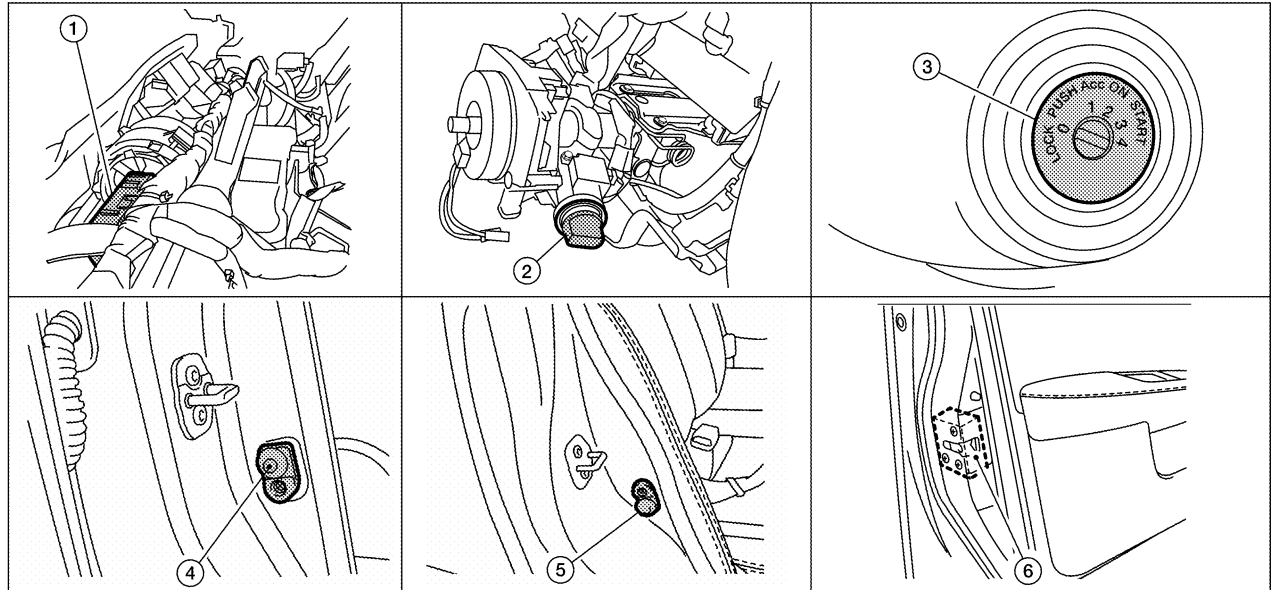

1. BCM M18, M19 and M20 (view with dash panel removed)
2. Key switch and ignition knob switch (with Intelligent Key) M49
3. Key switch (without Intelligent Key) M50
4. Front door switch LH B21 and RH B28
5. Rear door switch LH B26 and RH B41
6. Front door lock assembly LH (key cylinder switch) D9

System Description

EKS00JPB

When room lamp switch is in DOOR position, room lamp ON/OFF is controlled by timer according to signals from switches including key switch, front door switch LH, unlock signal from keyfob, door lock and unlock switch, key cylinder lock and unlock switch, ignition switch.

When room lamp turns ON, there is a gradual brightening over 1 second.

When room lamp turns OFF, there is a gradual dimming over 1 second.

Interior room lamp timer is controlled by BCM (body control module).

Interior room lamp timer control settings can be changed with CONSULT-III.

POWER SUPPLY AND GROUND

Power is supplied at all times (without Intelligent Key system)

- through 10A fuse [No. 19, located in fuse block (J/B)]
- to key switch terminal 2,
- through 10A fuse [No. 21, located in fuse block (J/B)]
- to BCM terminal 57,
- through 50A fusible link (letter j , located in fuse and fusible link box)
- to BCM terminal 70.

Power is supplied at all times (with Intelligent Key system)

- through 10A fuse (No. 9, located in fuse and fusible link box)
- to key switch and ignition knob switch terminals 2 and 4,
- through 10A fuse [No. 21, located in fuse block (J/B)]
- to BCM terminal 57,
- through 50A fusible link (letter j , located in fuse and fusible link box)
- to BCM terminal 70.

When key is inserted in the key switch, power is supplied (without Intelligent Key system)

- through key switch terminal 1
- to BCM terminal 37.

When key is inserted in the key switch and ignition knob switch, power is supplied (with Intelligent Key system)

INTERIOR ROOM LAMP

- through key switch and ignition knob switch terminal 1
- to BCM terminal 37.

When ignition knob switch is pushed, power is supplied (with Intelligent Key system)

- through key switch and ignition knob switch terminal 3
- to Intelligent Key unit terminal 27.

With the ignition switch in the ON or START position, power is supplied

- through 10A fuse [No. 12, located in fuse block (J/B)]
- to BCM terminal 38.

Ground is supplied

- to BCM terminal 67
- through grounds M57 and M61.

When front door LH is opened, ground is supplied

- to BCM terminal 47
- through front door switch LH terminal 2
- through case ground of front door switch LH.

When front door RH is opened, ground is supplied

- to BCM terminal 12
- through front door switch RH terminal 2
- through case ground of front door switch RH.

When rear door LH is opened, ground is supplied

- to BCM terminal 48
- through rear door switch LH terminal 2
- through case ground of rear door switch LH.

When rear door RH is opened, ground is supplied

- to BCM terminal 13
- through rear door switch RH terminal 2
- through case ground of rear door switch RH.

When trunk is opened, ground is supplied

- to BCM terminal 42
- through trunk room lamp switch terminal 1
- through trunk room lamp switch terminal 2
- through grounds B7 and B19.

When front door LH is unlocked by front door key cylinder switch LH, the BCM receives a ground signal

- to BCM terminal 7
- through front door key cylinder switch LH terminal 5
- through front door key cylinder switch LH terminal 4
- through grounds M57 and M61.

When a signal, or combination of signals is received by BCM, ground is supplied

- to interior room lamp terminal 1
- through BCM terminal 63.

With power and ground supplied, the interior room lamp illuminates.

SWITCH OPERATION

Power is supplied

- through BCM terminal 56
- to trunk room lamp terminal 1,
- to vanity mirror lamp LH and RH terminal 1 (with vanity lamps),
- to map lamp terminal 2 (with map lamp) and
- to interior room lamp terminal 2.

INTERIOR ROOM LAMP

When trunk room lamp is ON (trunk is open), ground is supplied

- to trunk room lamp terminal 2
- through BCM terminal 49.

When vanity mirror lamp LH or RH switch is ON (with vanity lamps), ground is supplied

- to vanity mirror lamp LH or RH terminal 2
- through grounds M57 and M61.

When map lamp switch is ON (with map lamp), ground is supplied

- to map lamp terminal 1
- through grounds M57 and M61.

When interior room lamp switch is ON, ground is supplied

- to interior room lamp
- through interior room lamp case ground.

INTERIOR ROOM LAMP TIMER OPERATION

Without Intelligent Key System

When room lamp switch is in DOOR position, and when all conditions below are met, BCM performs timer control (maximum 30 seconds) for room lamp ON/OFF.

In addition, when the interior room lamp turns ON or OFF there is gradual brightening or dimming over 1 second.

Power is supplied

- through 10A fuse [No. 19, located in fuse block (J/B)]
- to key switch terminal 2.

When the key is removed from ignition key cylinder (key switch OFF), power will not be supplied to BCM terminal 37.

When front door lock assembly LH (key cylinder switch) is unlocked, ground is supplied

- to BCM terminal 7
- through front door key cylinder switch LH terminal 5
- through front door key cylinder switch LH terminal 4
- through grounds M57 and M61.

At the time that front door LH is opened, BCM detects that front door LH is unlocked. It determines that interior room lamp timer operation condition is met, and turns the room lamp ON for 30 seconds.

When key is in ignition key cylinder,

Power is supplied

- through key switch terminal 1
- to BCM terminal 37.

When key is removed from key switch (key switch OFF), the power supply to BCM terminal 37 is terminated. BCM detects that key has been removed, determines that interior room lamp timer conditions are met, and turns the room lamp ON for 30 seconds.

When front door LH opens → closes, and the key is not inserted in the key switch (key switch OFF), voltage at BCM terminal 47 changes between 0V (door open) → 12V (door closed). The BCM determines that conditions for room lamp operation are met and turns the room lamp ON for 30 seconds.

Interior room lamp timer control is canceled under the following conditions

- Front door LH is locked (locked front door key cylinder switch LH).
- Front door LH is opened (front door switch LH).
- Ignition switch ON.

With Intelligent Key System

When the room lamp switch is in DOOR position, and when all conditions below are met, BCM performs timer control (maximum 30 second) for room lamp ON/OFF.

In addition, when interior room lamp turns ON or OFF there is gradual brightening or dimming over 1 second.

Power is supplied

- through 10A fuse [No. 9, located in fuse block (J/B)]
- to key switch and ignition knob switch terminals 2 and 4.

A
B
C
D
E
F
G
H
I
J
LT
L
M

INTERIOR ROOM LAMP

When key is removed from ignition key cylinder (key switch OFF), power will not be supplied to BCM terminal 37.

When the ignition knob switch is released, power will not be supplied to Intelligent Key unit terminal 27.

When front door key cylinder switch LH is unlocked, ground is supplied

- to BCM terminal 7
- through front door key cylinder switch LH terminal 5
- through front door key cylinder switch LH terminal 4
- through grounds M57 and M61.

At the time the front door LH is opened, the BCM detects the front door LH is unlocked. It determines that the interior room lamp timer operation conditions are met, and interior room lamp ON for 30 seconds.

When the key is in ignition key cylinder (key switch ON), or ignition knob switch is pushed, power is supplied

- through key switch and ignition knob switch terminal 1
- to BCM terminal 37, or
- through key switch and ignition knob switch terminal 3
- to Intelligent Key unit terminal 27.

When the key is removed from key switch (key switch OFF), power supply to BCM terminal 37 is terminated. When the ignition knob switch is released, power supply to intelligent key unit is terminated. The BCM detects that the key has been removed, determines that interior room lamp timer conditions are met, and turns room lamp ON for 30 seconds.

When the front door LH opens → closes, and key is not inserted in key switch (or ignition knob switch is released), BCM terminal 47 changes between 0V (door open) → 12V (door closed). BCM determines that conditions for room lamp operation are met, and turns room lamp ON for 30 seconds.

Interior room lamp timer control is canceled under the following conditions:

- Front door LH is locked (with keyfob or front door key cylinder switch LH).
- Front door LH is opened (front door switch LH).
- Ignition switch ON.

INTERIOR LAMP BATTERY SAVER CONTROL

If an interior room lamp is left ON, it will not be turned OFF even when door is closed.

BCM turns off interior lamp automatically to save battery 30 minutes after ignition switch is turned off.

After lamps are turned OFF by the battery saver system, the lamps illuminate again when

- front door key cylinder switch LH is locked or unlocked
- door is opened or closed
- key is removed from ignition key cylinder or inserted in ignition key cylinder, or the ignition knob switch is pushed or released (with intelligent key system).

Interior lamp battery saver control time period can be changed by the function setting of CONSULT-III.

INTERIOR ROOM LAMP

EKS00JPC

Schematic

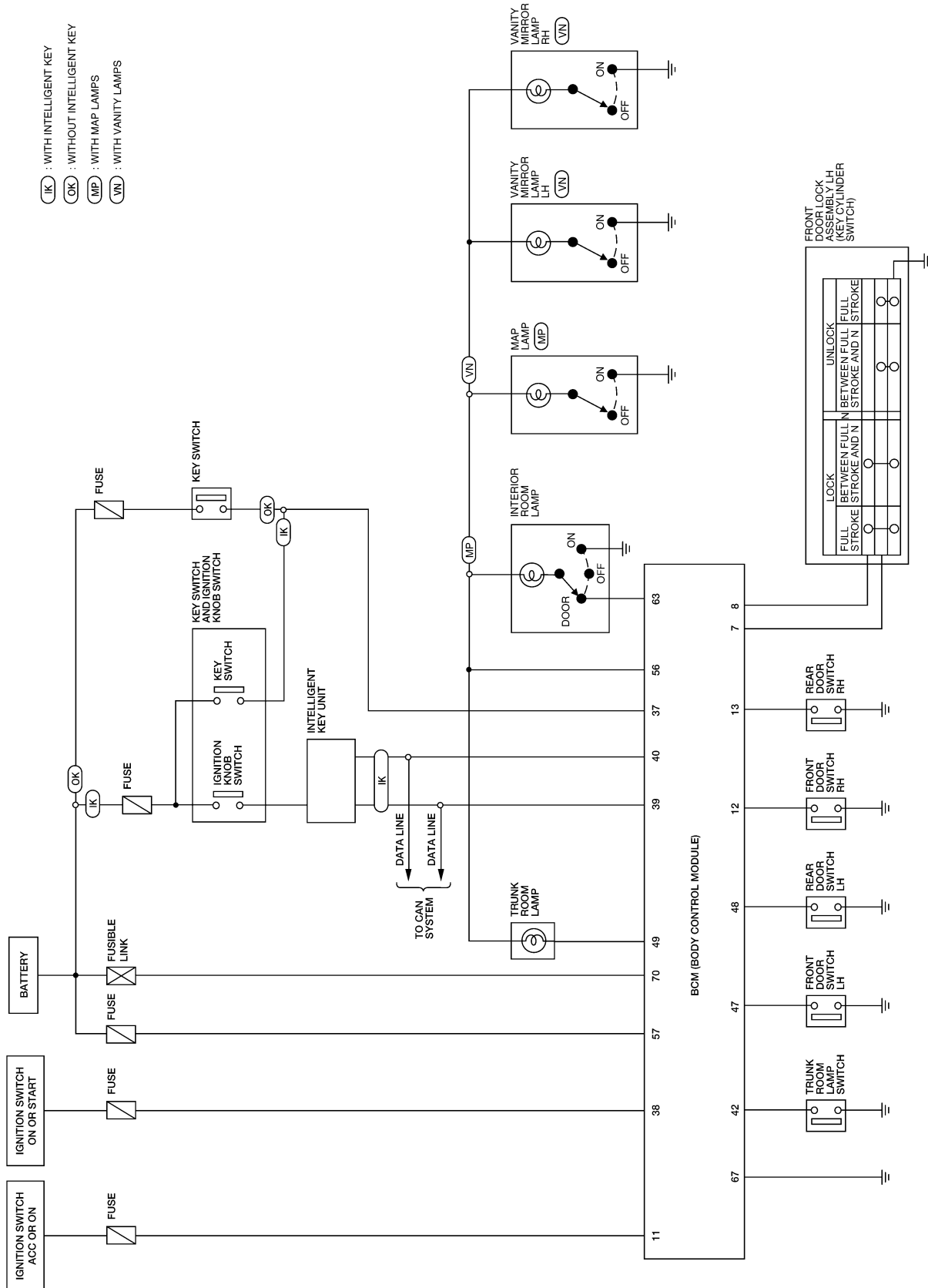

WKWA5863E

A
B
C
D
E
F
G
H
I
J
K
L
M

LT

INTERIOR ROOM LAMP

Wiring Diagram — INT/L —

EKS00JPD

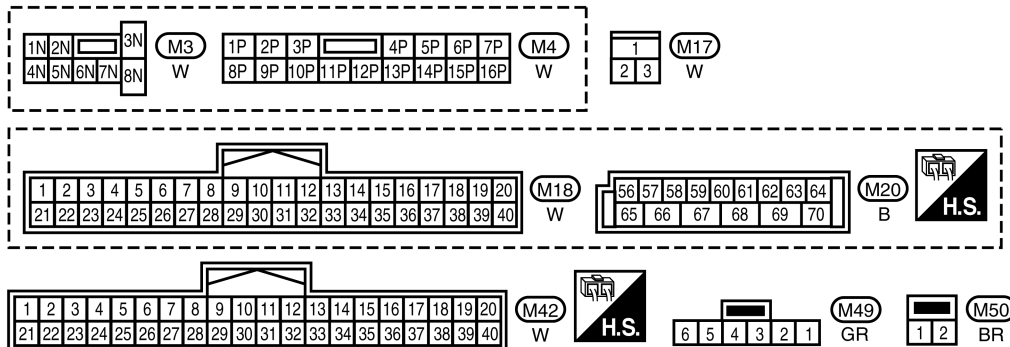
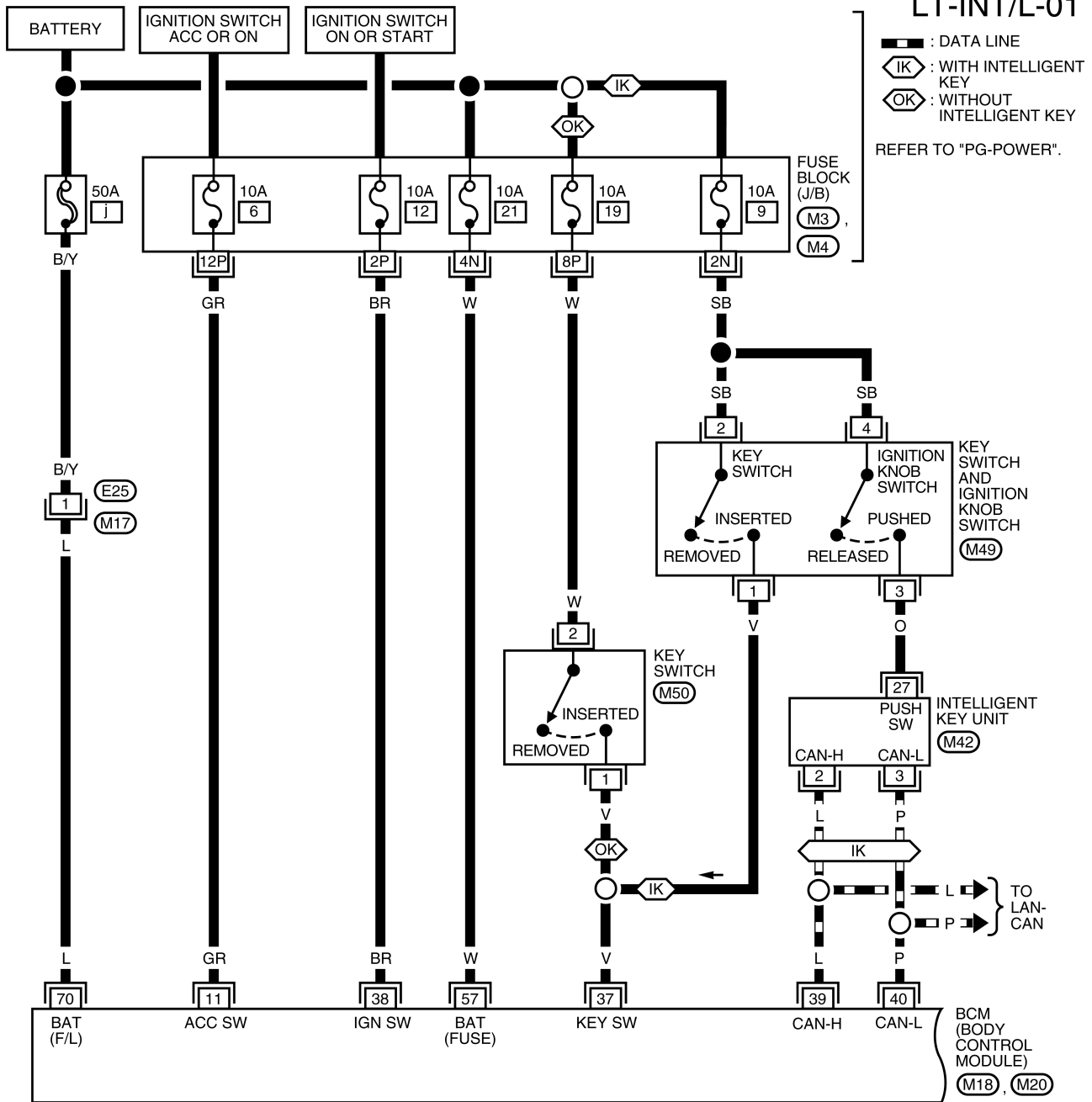

WKWA5864E

INTERIOR ROOM LAMP

LT-INTL/L-02

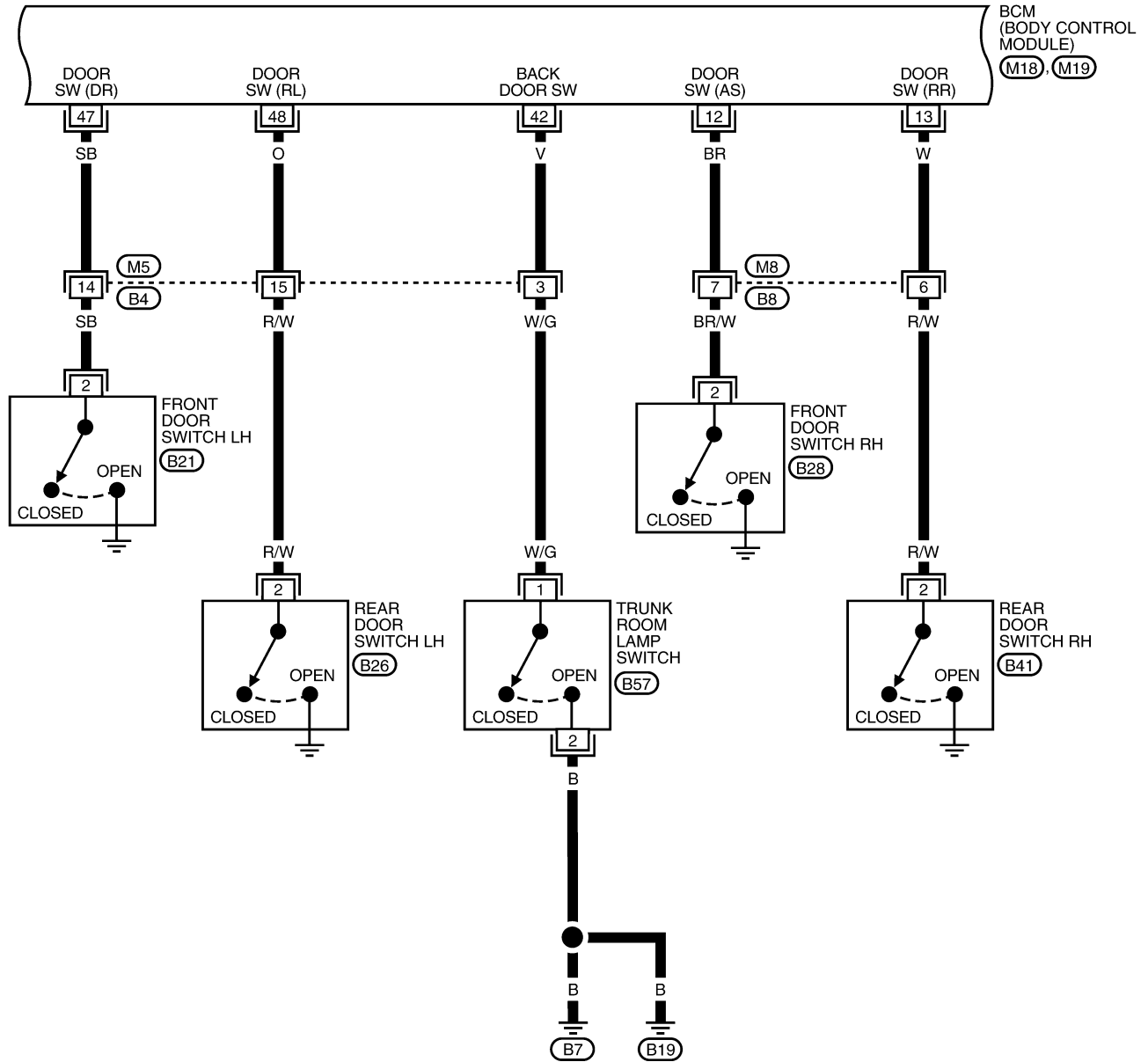

1	2	3	4	5	6	7	(M5)	(M8)		
8	9	10	11	12	13	14	15	16	GR	W

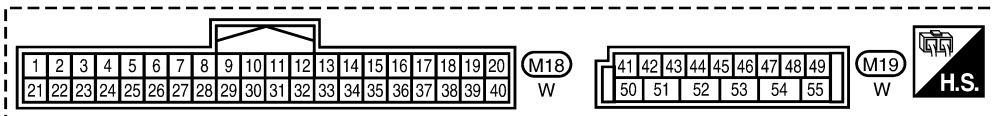

1	(B21)	(B26)	(B28)	(B41)		(B57)
2	W	W	W	W	2 1	W
3						

BKWA0805E

INTERIOR ROOM LAMP

LT-INT/L-03

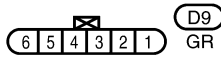
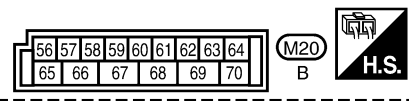
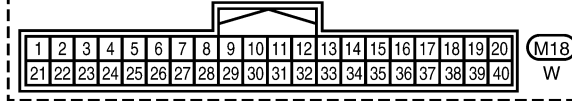
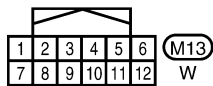
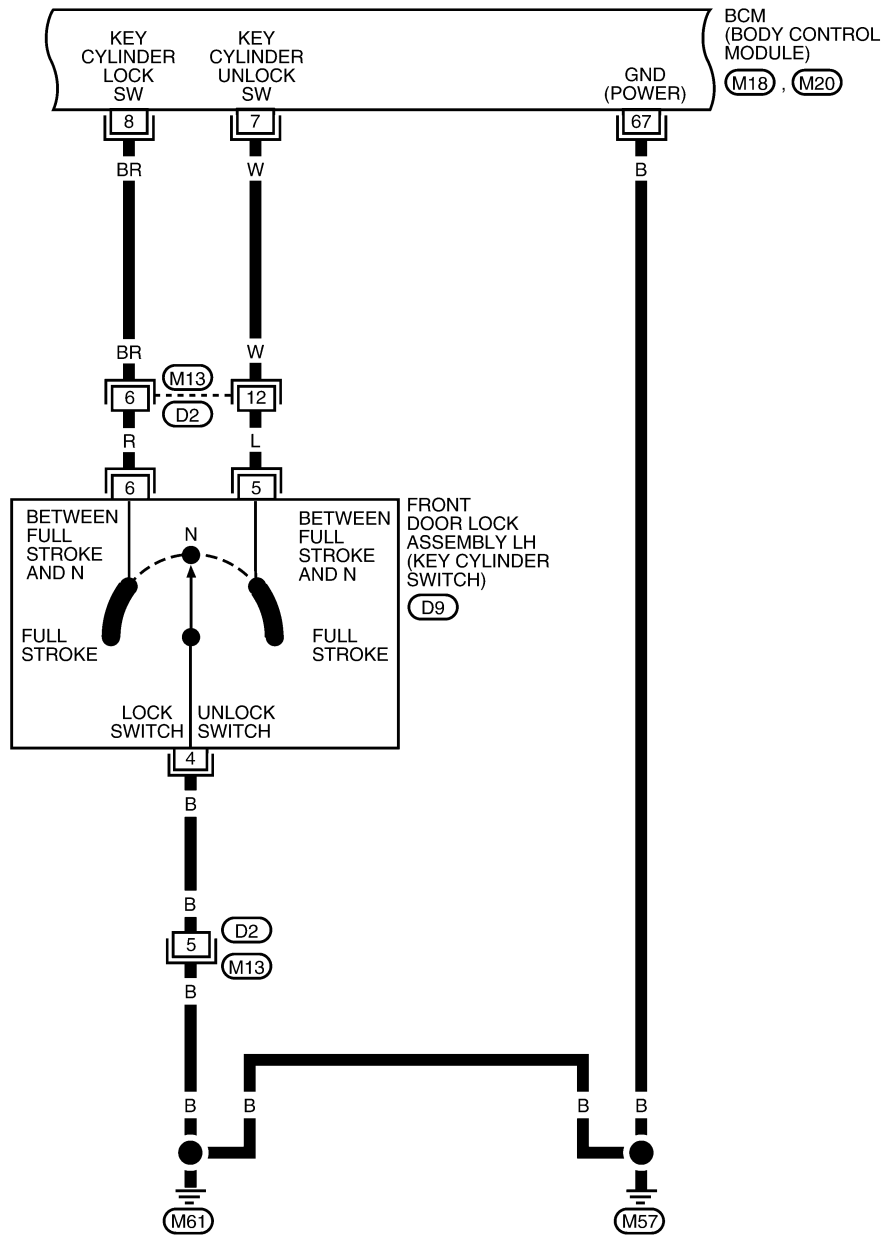

BKWA0806E

INTERIOR ROOM LAMP

LT-INT/L-04

MP : WITH MAP LAMPS
 VN : WITH VANITY LAMPS

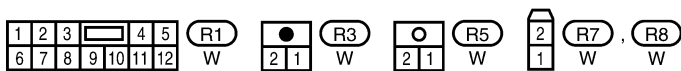
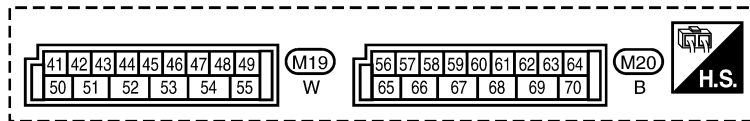
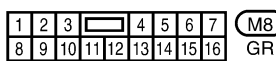
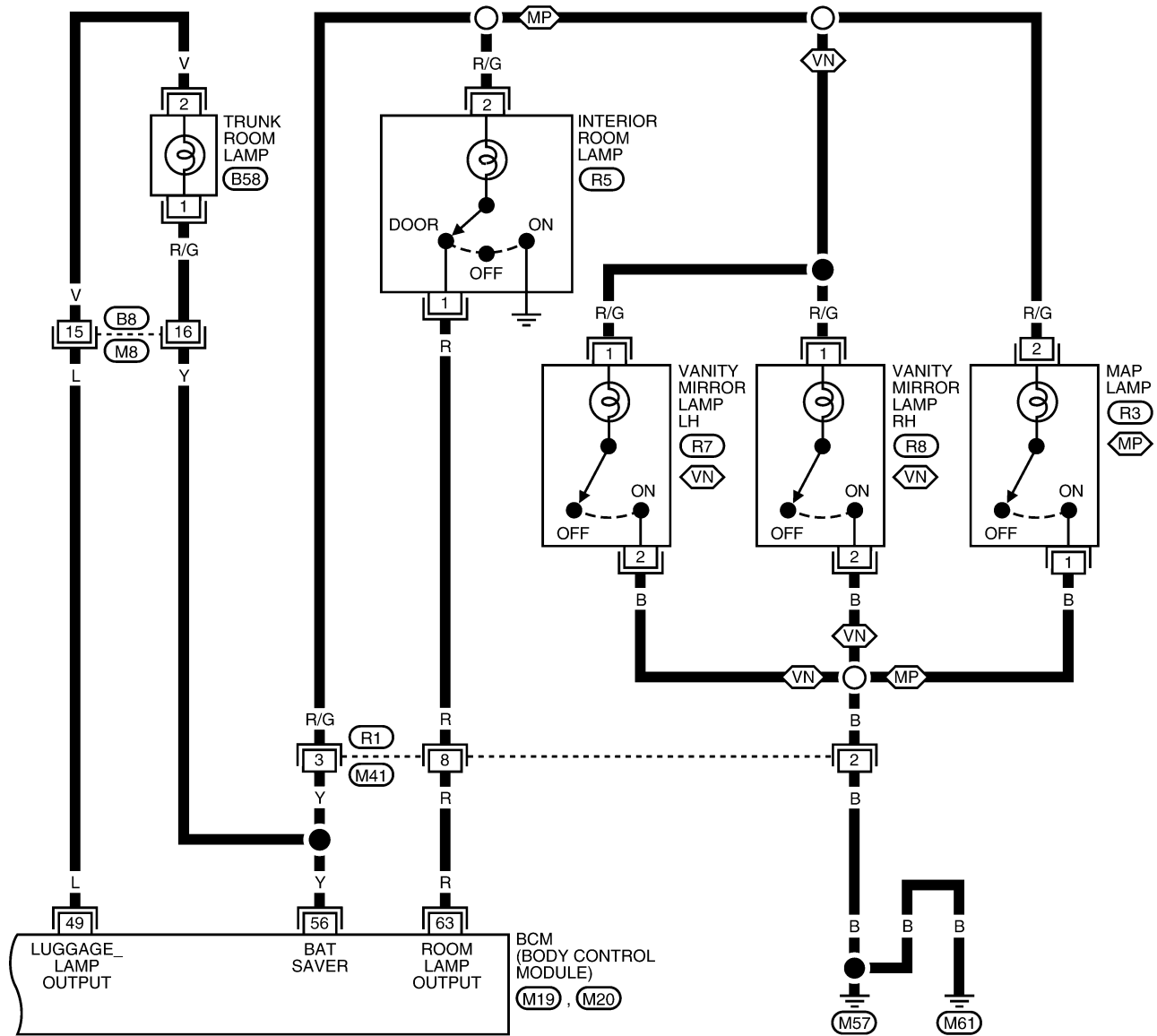

BKWA0807E

INTERIOR ROOM LAMP

Terminals and Reference Values for BCM

EKS00JPE

Refer to [BCS-13, "Terminals and Reference Values for BCM"](#) .

How to Proceed With Trouble Diagnosis

EKS00JPF

1. Confirm the symptom or customer complaint.
2. Understand operation description and function description. Refer to [LT-89, "System Description"](#) .
3. Perform the preliminary check. Refer to [LT-98, "Preliminary Check"](#) .
4. Check symptom and repair or replace the cause of the malfunction.
5. Does the interior room lamp operate normally? If YES, GO TO 6. If NO, GO TO 4.
6. Inspection end.

Preliminary Check

EKS00JPG

CHECK POWER SUPPLY AND GROUND CIRCUIT FOR BCM

Refer to [BCS-16, "BCM Power Supply and Ground Circuit Check"](#) .

CONSULT-III Function (BCM)

EKS00L50

Refer to [BCS-18, "CONSULT-III Function \(BCM\)"](#)

WORK SUPPORT

Display Item List

Item	Description	CONSULT-III
SET I/L D-UNLCK INTCON	The 30 second operating function of the interior room lamps can be selected when the front door LH is released (unlocked).	ON/OFF
ROOM LAMP ON TIME SET	The time in order to escalate illumination can be adjusted when interior room lamps are turned on.	MODE 1 – 7
ROOM LAMP OFF TIME SET	The time in order to diminish illumination can be adjusted when interior room lamps are turned off.	MODE 1 – 7

Reference between "MODE" and "TIME" for "TURN ON/OFF"

MODE	1	2	3	4	5	6	7
Time (sec.)	0.5	1	2	3	4	5	0

DATA MONITOR

Display Item List

Monitor item	Contents
IGN ON SW	"ON/OFF" Displays "IGN position (ON)/OFF, ACC position (OFF)" judged from ignition switch signal.
KEY ON SW	"ON/OFF" Displays "Key inserted (ON)/key removed (OFF)" status judged from key switch signal.
DOOR SW - DR	"ON/OFF" Displays status of front door LH as judged from front door switch LH signal. (Door is open: ON/Door is closed: OFF)
DOOR SW - AS	"ON/OFF" Displays "Door open (ON)/Door closed (OFF)" status, determined from front door switch RH signal.
DOOR SW - RR	"ON/OFF" Displays "Door open (ON)/Door closed (OFF)" status, determined from rear door switch RH signal.
DOOR SW - RL	"ON/OFF" Displays "Door open (ON)/Door closed (OFF)" status, determined from rear door switch LH signal.
BACK DOOR SW	"ON/OFF" Displays "Door open (ON)/Door closed (OFF)" status, determined from rear door switch BACK signal.
KEY CYL LK-SW	"ON/OFF" Displays "Door locked (ON)" status, determined from key cylinder lock switch in front door LH.
KEY CYL UN-SW	"ON/OFF" Displays "door unlocked (OFF)" status, determined from key cylinder lock switch in front door LH.

INTERIOR ROOM LAMP

Monitor item	Contents
CDL LOCK SW "ON/OFF"	Displays "Door locked (ON)/Door unlocked (OFF) status, determined from locking detection switch in the front door LH.
CDL UNLOCK SW "ON/OFF"	Displays "Door unlocked (OFF)" status, determined from locking detection switch in front door RH.
KEYLESS LOCK "ON/OFF"	Displays "Locked (ON)/Other (OFF)" status, determined from lock signal.
KEYLESS UNLOCK "ON/OFF"	Displays "Unlocked (ON)/Other (OFF)" status, determined from unlock signal.

ACTIVE TEST

Display Item List

Test item	Description
INT LAMP	Interior room lamp can be operated by any ON-OFF operations.

Interior Room Lamp Control Does Not Operate

EKS00JPJ

1. CHECK EACH SWITCH

Select "BCM" on CONSULT-III. With "INT LAMP" data monitor, make sure switches listed in display item list turn ON-OFF linked with switch operation. Refer to [LT-98, "Display Item List"](#) for switches and their functions.

OK or NG

OK >> GO TO 2.

NG >> Inspect malfunctioning switch system.

2. ACTIVE TEST

1. Select "BCM" on CONSULT-III. Select "INT LAMP" active test.
2. When room lamp switch is in DOOR position, make sure room lamp operates.

Room lamp should operate.

OK or NG

OK >> Replace BCM. Refer to [BCS-21, "Removal and Installation of BCM"](#).

NG >> GO TO 3.

3. CHECK ROOM LAMP INPUT VOLTAGE

1. Turn ignition switch OFF.
2. Check voltage between interior room lamp harness connector R5 terminal 2 and ground.

2 - Ground : Battery voltage should exist.

OK or NG

OK >> GO TO 4.

NG >> GO TO 5.

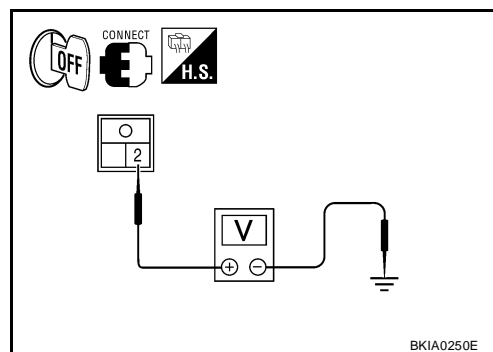

INTERIOR ROOM LAMP

4. CHECK ROOM LAMP

1. Disconnect room lamp connector.
2. Check continuity between room lamp terminals.

Room lamp		Condition	Continuity
Terminal			
1	2	Room lamp switch is in DOOR position	Yes
		Room lamp switch is in OFF position	No

OK or NG

OK >> GO TO 6.

NG >> Check bulb. If OK, replace room lamp. Refer to [LT-101, "ROOM LAMP"](#) .

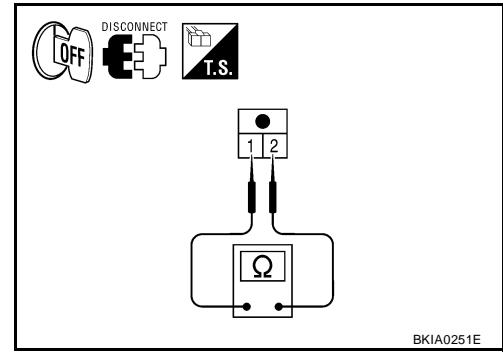

5. CHECK ROOM LAMP CIRCUIT

1. Disconnect BCM and interior room lamp connectors.
2. Check continuity between BCM harness connector M20 (A) terminal 56 and room lamp harness connector R5 (B) terminal 2.

56 - 2 : Continuity should exist.

OK or NG

OK >> GO TO 6.

NG >> Repair harness or connector.

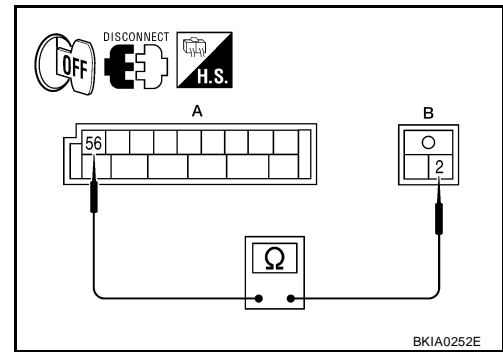

6. CHECK ROOM LAMP CIRCUIT

1. Disconnect BCM connector.
2. Check continuity between BCM harness connector M20 (A) terminal 63 and room lamp harness connector R5 (B) terminal 1.

63 - 1 : Continuity should exist.

OK or NG

OK >> Replace BCM if interior lamp does not work after setting the connector again. Refer to [BCS-21, "Removal and Installation of BCM"](#) .

NG >> Repair harness or connector.

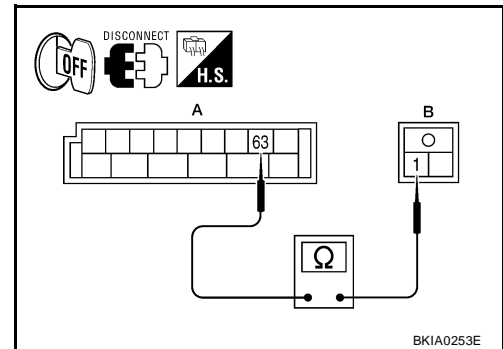

Bulb Replacement ROOM LAMP

1. Remove the interior lamp lens.
2. Push the interior lamp metal tab (B) and remove the bulb.
 - Interior lamp screws (A)
3. Installation is in the reverse order of removal.

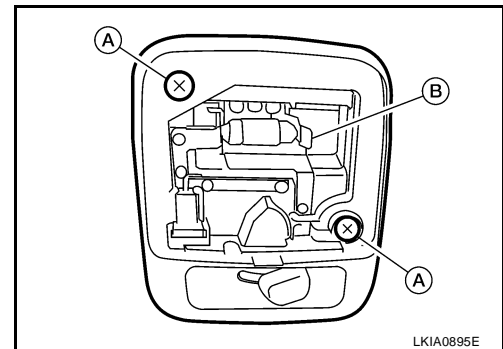

EKS00JPK

INTERIOR ROOM LAMP

EKS00JPL

Removal and Installation ROOM LAMP

Removal

1. Remove the interior lamp lens and remove the interior room lamp screws (A).
 - Metal tab (B)
2. Disconnect the connector and remove the interior room lamp.

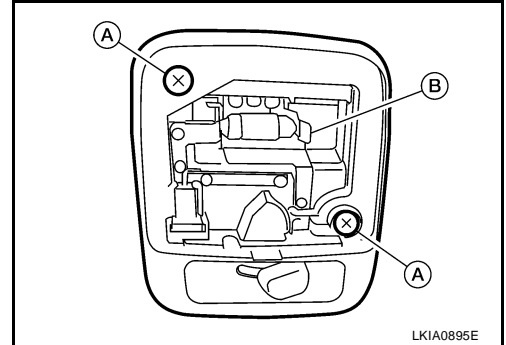

Installation

Installation is in the reverse order of removal.

A
B
C
D
E
F
G
H
I
J
LT
L
M

LT

ILLUMINATION

PFP:27545

System Description

EKS00JPM

The control of the illumination lamps operation is dependent upon the position of the lighting switch. When the lighting switch is placed in the 1ST or 2ND position, the BCM (body control module) receives input signal requesting the illumination lamps to illuminate. This input signal is communicated to IPDM E/R (intelligent power distribution module engine room) across CAN communication lines. CPU (central processing unit) located in the IPDM E/R controls the tail lamp relay coil. This relay, when energized, directs power to the illumination lamps, which then illuminate.

Power is supplied at all times

- to ignition relay, located in IPDM E/R,
- to tail lamp relay, located in IPDM E/R,
- through 15A fuse (No. 52, located in IPDM E/R) and
- through 20A fuse (No. 53, located in IPDM E/R)
- to CPU located in IPDM E/R,
- through 50A fusible link (letter j , located in fuse and fusible link box)
- to BCM terminal 70, and
- through 10A fuse [No. 21, located in fuse block (J/B)]
- to BCM terminal 57,
- through 10A fuse [No. 19, located in fuse block (J/B)]
- to combination meter terminal 1.

With the ignition switch in the ACC or ON position, power is supplied

- through 10A fuse [No. 6, located in fuse block (J/B)]
- to BCM terminal 11.

With the ignition switch in the ON or START position, power is supplied

- to ignition relay, located in IPDM E/R, and
- through 10A fuse [No. 12, located in fuse block (J/B)]
- to BCM terminal 38,
- through 10A fuse [No. 14, located in fuse block (J/B)]
- to combination meter terminal 2.

Ground is supplied

- to BCM terminal 67,
- to combination meter terminals 3, 21 and 22 and
- to glove box lamp terminal 2
- through grounds M57 and M61, and
- to IPDM E/R terminals 39 and 59
- through grounds E9, E15 (all models) and E24 (with MR20DE).

ILLUMINATION OPERATION BY LIGHTING SWITCH

With the lighting switch in the 1ST or 2ND position, BCM receives input signal requesting the illumination lamps to illuminate. This input signal is communicated to IPDM E/R across CAN communication lines. CPU located in the IPDM E/R controls the tail lamp relay coil, which, when energized, directs power

- through 10A fuse (No. 36, located in IPDM E/R)
- through IPDM E/R terminal 27
- to audio unit terminal 9,
- to front air control terminal 23,
- to hazard switch terminal 3
- to manual mode select switch terminal 4
- through resistor 1 terminals 2 and 1
- through combination switch (spiral cable) terminals 34 and 14
- to steering wheel audio control switch (if equipped)

ILLUMINATION

- to ASCD steering switch (if equipped),
- to steering shift switch (if equipped),
- to console lamp LH, CENTER and RH terminal 1,
- to CVT device terminal 1 (with CVT),
- to Bluetooth ON indicator terminal 3 (with Bluetooth)
- to double meter terminal 11 (with double meter) and
- to glove box lamp terminal 1.

A

B

C

Illumination is controlled

- through combination meter terminal 14
- to console lamp LH, CENTER and RH terminal 2 and
- to CVT device terminal 2 (with CVT).

D

The illumination control switch controls illumination intensity by varying ground

- through combination meter terminal 13
- to audio unit terminal 8
- to front air control terminal 24
- to hazard switch terminal 4,
- to manual mode select switch terminal 5
- through combination switch (spiral cable) terminals 21 and 27
- to steering wheel audio control switch (if equipped)
- to ASCD steering switch (if equipped) and
- to steering shift switch (if equipped),
- through combination meter terminal 33 (with double meter)
- to double meter terminal 12.

E

F

G

H

With power and ground supplied, illumination lamps illuminate.

I

CAN Communication System Description

EKS00JPN

Refer to [LAN-4, "SYSTEM DESCRIPTION"](#) .

J

LT

L

M

ILLUMINATION

Schematic

EKS00JPO

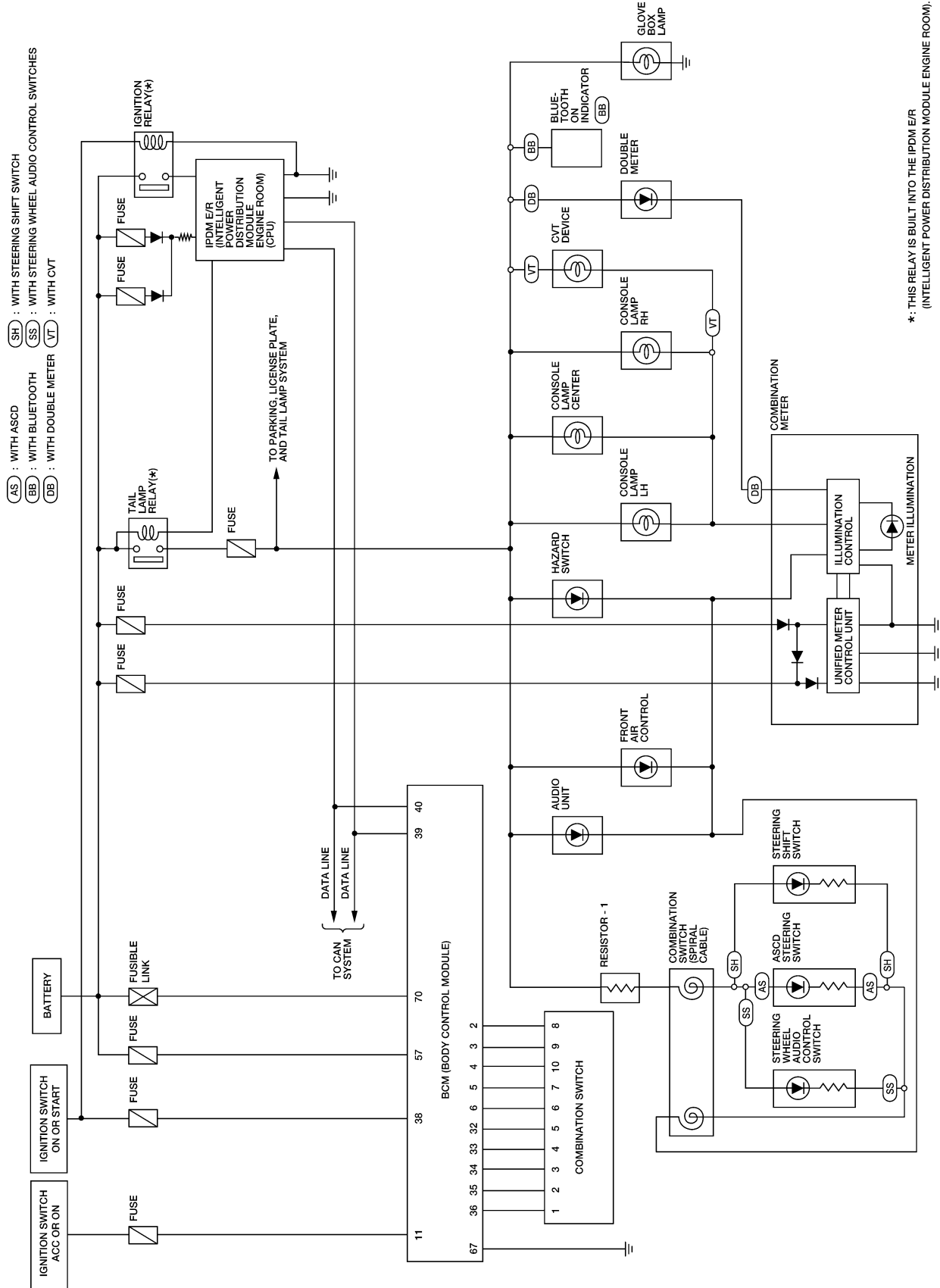

BKWA0840E

ILLUMINATION

Wiring Diagram — ILL —

EKS00JPP

LT-ILL-01

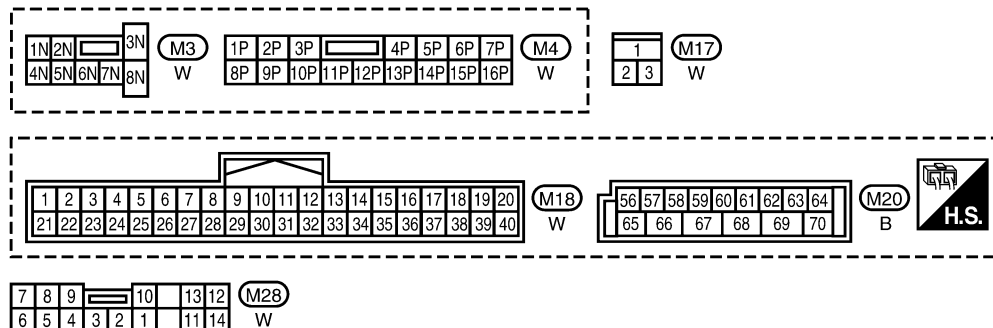
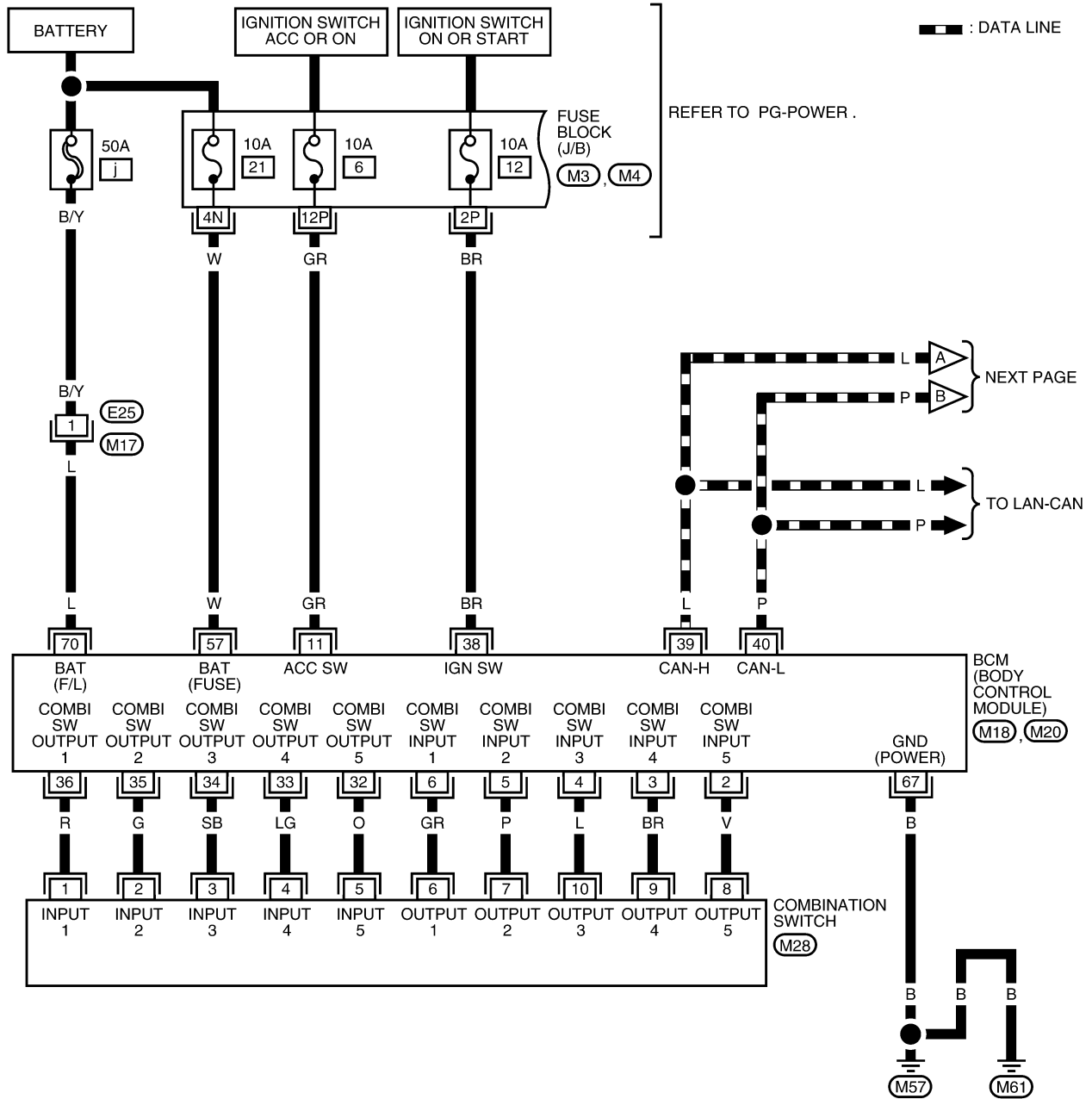

BKWA0809E

ILLUMINATION

LT-ILL-02

▬ : DATA LINE

MR : WITH MR20DE

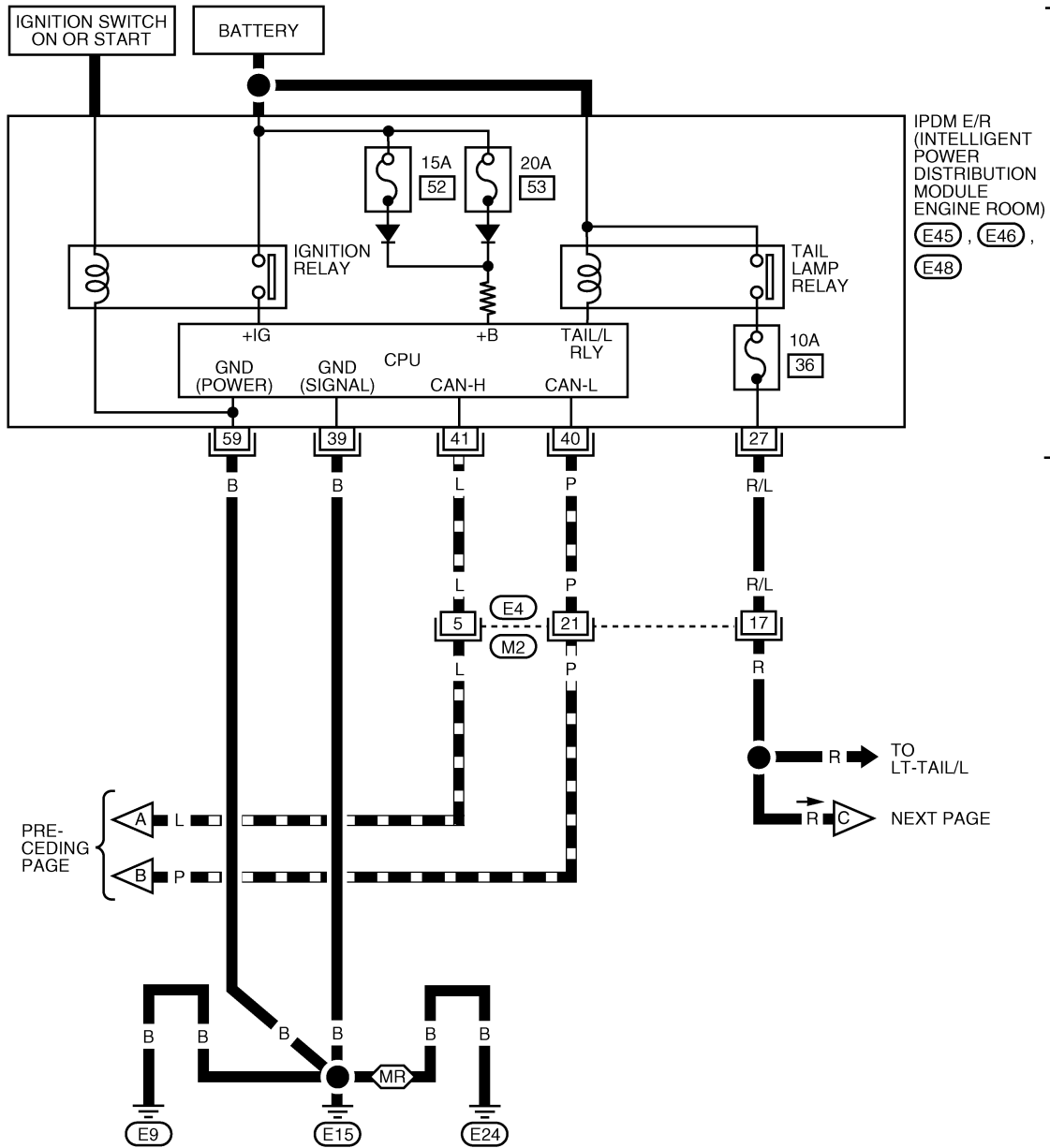

IPDM E/R
(INTELLIGENT
POWER
DISTRIBUTION
MODULE
ENGINE ROOM)
E45, E46,
E48

REFER TO
"PG-POWER".

PRE-
CEDING
PAGE

TO
LT-TAIL/L
NEXT PAGE

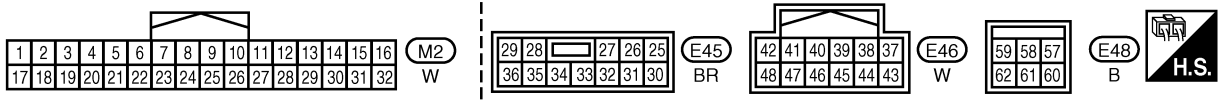

BKWA0841E

ILLUMINATION

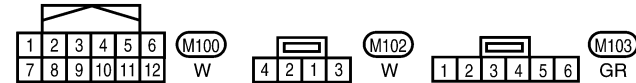
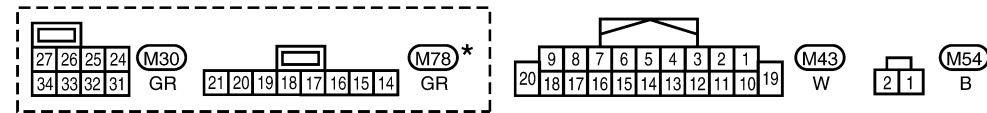
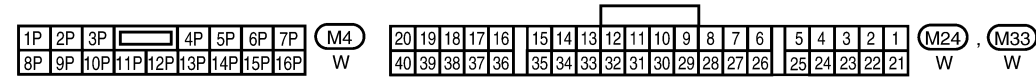
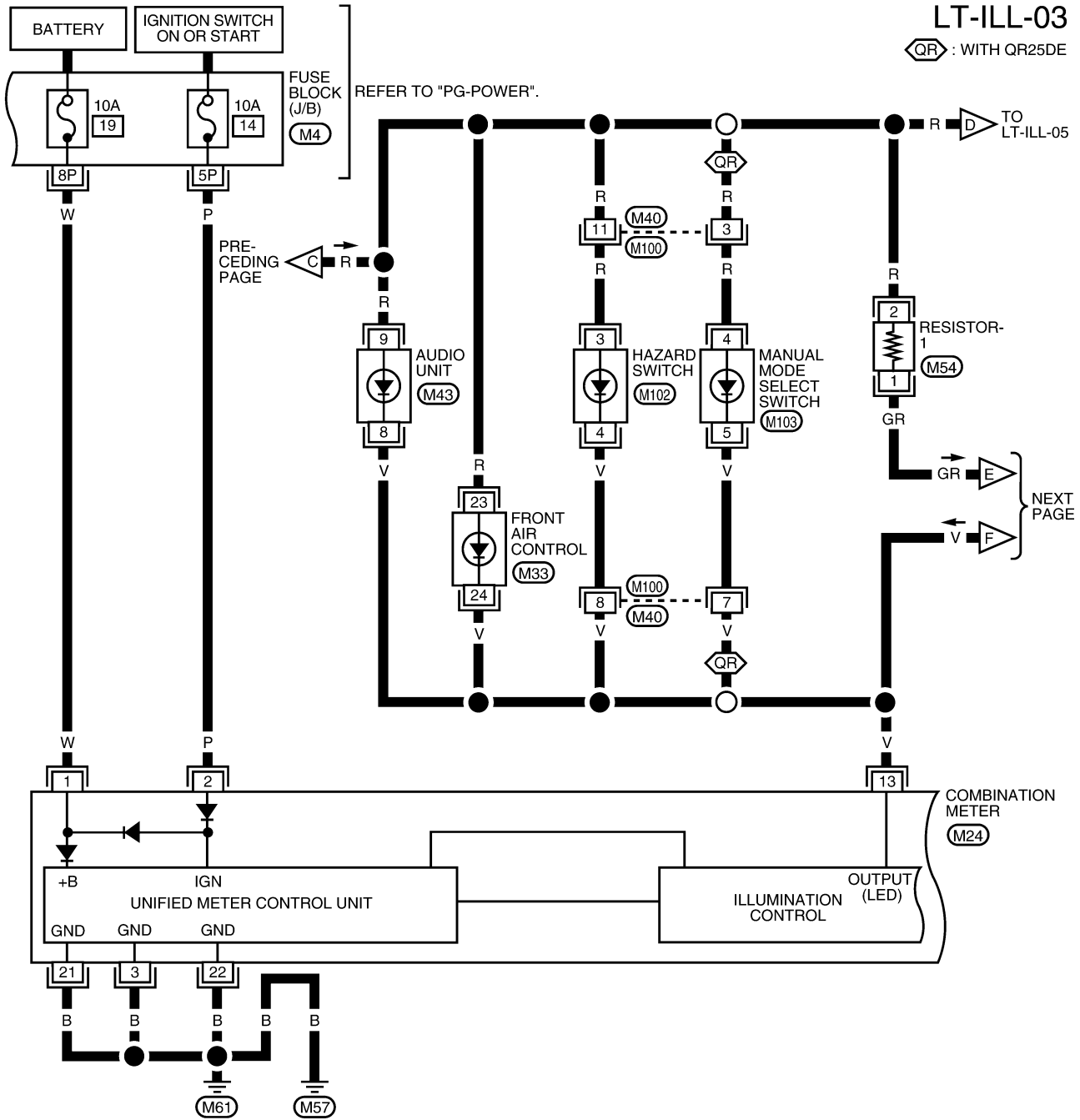

* : THIS CONNECTOR IS NOT SHOWN IN "HARNESS LAYOUT" OF PG SECTION.

BKWA0842E

ILLUMINATION

LT-ILL-04

- ⬡ AS : WITH ASCD
- ⬡ SH : WITH STEERING SHIFT SWITCH
- ⬡ SS : WITH STEERING WHEEL AUDIO CONTROL SWITCHES

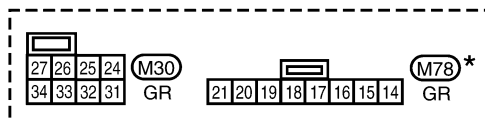
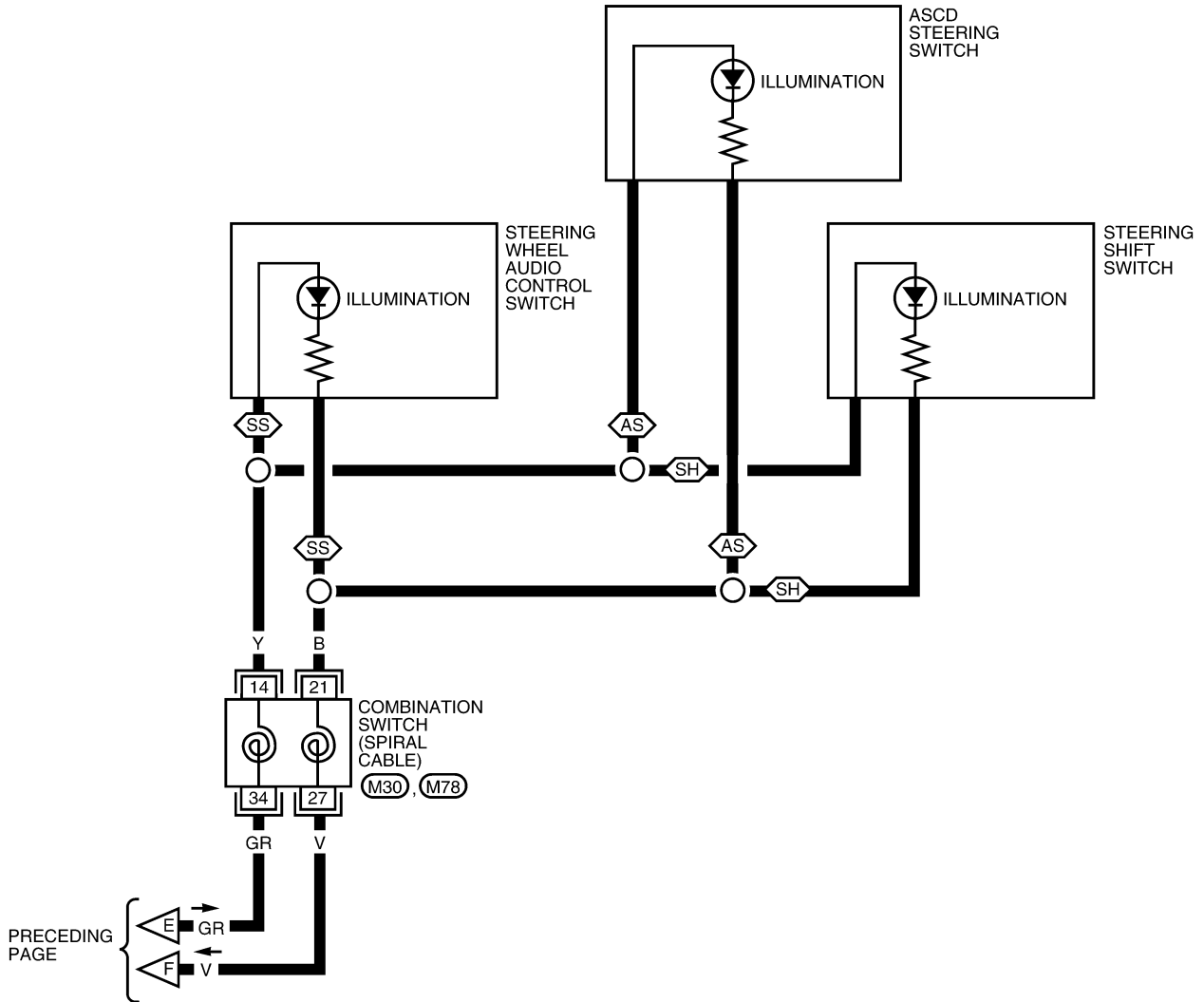



* : THIS CONNECTOR IS NOT SHOWN IN "HARNESS LAYOUT" OF PG SECTION.

BKWA0843E

ILLUMINATION

LT-ILL-05

-  : WITH BLUETOOTH
-  : WITH DOUBLE METER
-  : WITH CVT

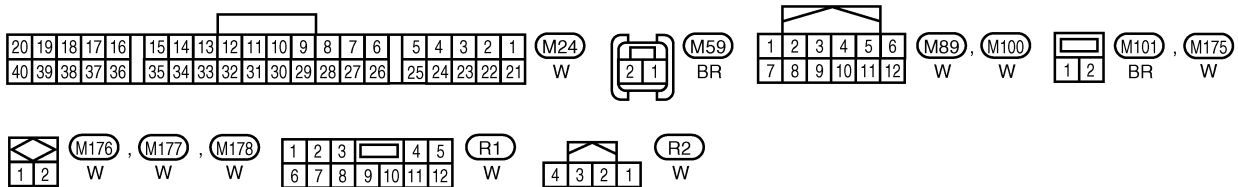
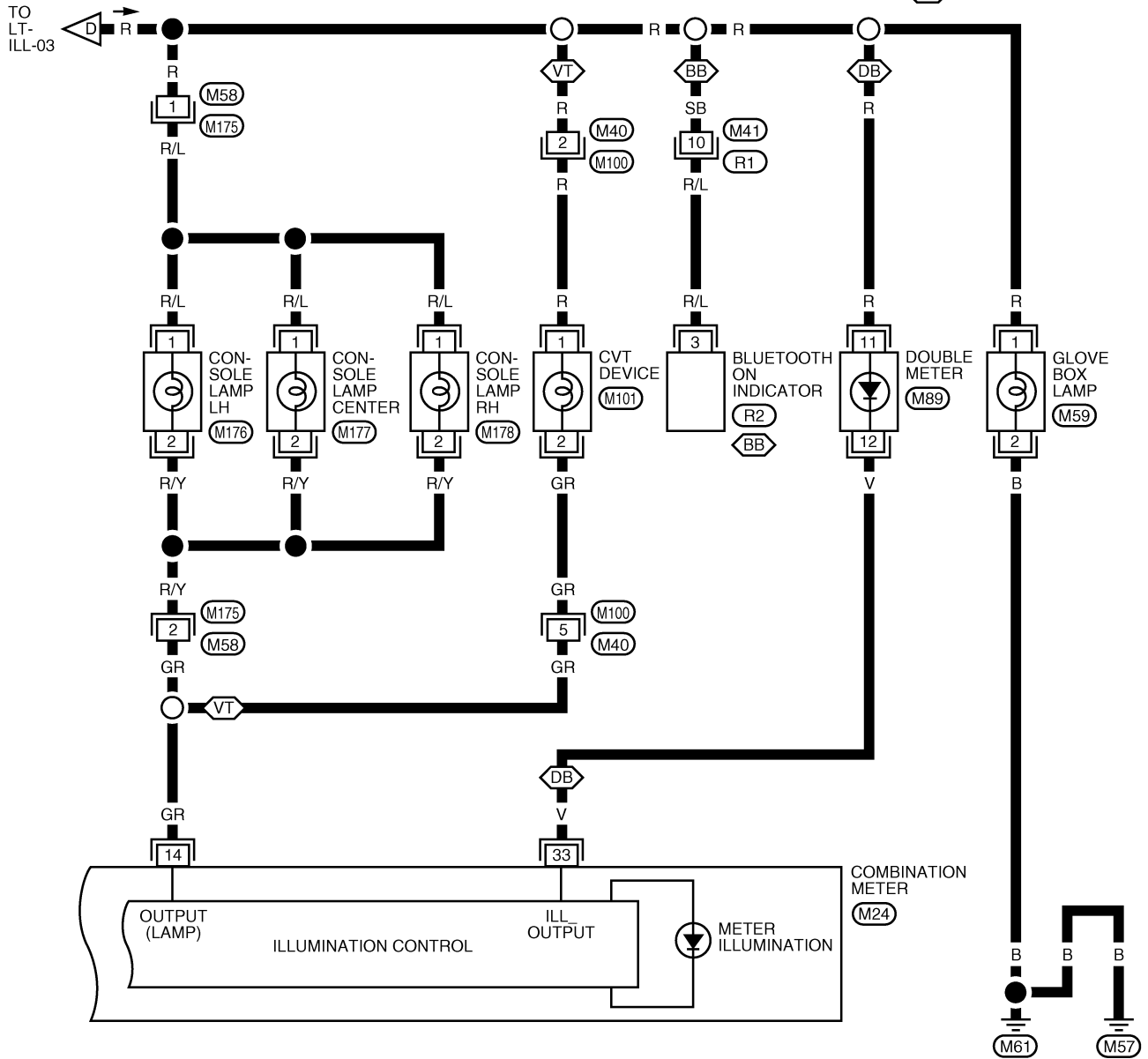

BKWA0844E

ILLUMINATION

Bulb Replacement GLOVE BOX LAMP

EKS00JPO

1. Remove glove box assembly. Refer to [IP-10, "INSTRUMENT PANEL ASSEMBLY"](#) .
2. Turn bulb socket (1) counterclockwise and remove it.
3. Remove the bulb.
4. Installation of the bulb is in the reverse order of removal.

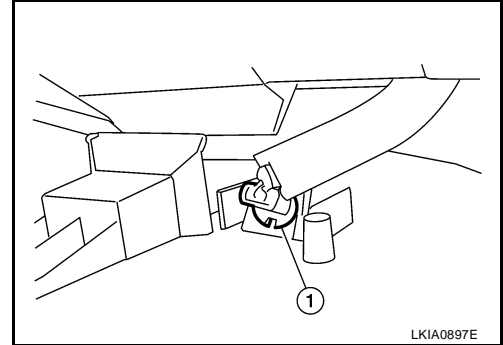

MOOD LAMP

1. Remove the instrument upper cover (center). Refer to [IP-10, "Component Parts"](#) .
2. Twist the mood lamp socket and remove the bulb.
3. Installation of the bulb is in the reverse order of removal.

Removal and Installation

MOOD LAMP

EKS00KYJ

The mood lamp is part of the instrument upper cover (center) and is replaced as an assembly. Refer to [IP-10, "Component Parts"](#) .

BULB SPECIFICATIONS

BULB SPECIFICATIONS

PFP:26297

Headlamp

EKS00JPR

Item	Bulb No.*	Wattage (W)
High/Low (halogen type)	H13	60/55

*: Always check with the Parts Department for the latest parts information.

Exterior Lamp

EKS00JPS

Item	Bulb No.*	Wattage (W)
Front combination lamp	Turn signal lamp	3457 AK
	Parking (clearance) lamp	194
	Side marker lamp	194
Rear combination lamp	Stop / tail lamp	3057K
	Turn signal lamp	3057K
	Back-up lamp	921
	Side marker lamp	194
Front fog lamp	H11	55
License plate lamp	216	5
High-mounted stop lamp (parcel shelf mount)	921	16
High-mounted stop lamp (rear air spoiler mount)	LED	

*: Always check with the Parts Department for the latest parts information.

Interior Lamp/Illumination

EKS00JPT

Item	Wattage (W)*
Glove box lamp	1.4
Map lamp	8
Room lamp	8
Luggage compartment lamp	5

*: Always check with the Parts Department for the latest parts information.

BULB SPECIFICATIONS
