

SECTION **CL**  
CLUTCH

A  
B  
CL

D

E

CONTENTS

<b>PRECAUTIONS</b> .....	<b>2</b>	<b>CSC (CONCENTRIC SLAVE CYLINDER)</b> .....	<b>11</b>	F
Precautions for Supplemental Restraint System (SRS) "AIR BAG" and "SEAT BELT PRE-TENSIONER" .....	2	Removal and Installation .....	11	
Service Notice or Precautions .....	2	REMOVAL .....	11	
<b>PREPARATION</b> .....	<b>3</b>	INSTALLATION .....	11	G
Special Service Tools .....	3	<b>CLUTCH PIPING</b> .....	<b>12</b>	
Commercial Service Tools .....	3	Removal and Installation .....	12	
<b>NOISE, VIBRATION AND HARSHNESS (NVH)</b>		REMOVAL .....	12	H
<b>TROUBLESHOOTING</b> .....	<b>4</b>	INSTALLATION .....	12	
NVH Troubleshooting Chart .....	4	<b>CLUTCH DISC, CLUTCH COVER AND FLYWHEEL..</b>	<b>13</b>	
<b>CLUTCH PEDAL</b> .....	<b>5</b>	Removal and Installation .....	13	I
On-vehicle Inspection and Adjustment .....	5	COMPONENTS .....	13	
Removal and Installation .....	7	REMOVAL .....	13	
COMPONENTS .....	7	INSPECTION AND ADJUSTMENT AFTER		
REMOVAL .....	7	REMOVAL .....	14	J
INSPECTION AFTER REMOVAL .....	7	INSTALLATION .....	15	
INSTALLATION .....	7	<b>SERVICE DATA AND SPECIFICATIONS (SDS)</b> .....	<b>16</b>	
<b>CLUTCH FLUID</b> .....	<b>8</b>	Clutch Control System .....	16	K
Air Bleeding Procedure .....	8	Clutch Pedal .....	16	
<b>CLUTCH MASTER CYLINDER</b> .....	<b>9</b>	Clutch Disc .....	16	L
Removal and Installation .....	9	Clutch Cover .....	16	
REMOVAL .....	9			
INSTALLATION .....	9			M

# PRECAUTIONS

## PRECAUTIONS

PF0:00001

### Precautions for Supplemental Restraint System (SRS) “AIR BAG” and “SEAT BELT PRE-TENSIONER”

ECS001YF

The Supplemental Restraint System such as “AIR BAG” and “SEAT BELT PRE-TENSIONER”, used along with a front seat belt, helps to reduce the risk or severity of injury to the driver and front passenger for certain types of collision. This system includes seat belt switch inputs and dual stage front air bag modules. The SRS system uses the seat belt switches to determine the front air bag deployment, and may only deploy one front air bag, depending on the severity of a collision and whether the front occupants are belted or unbelted. Information necessary to service the system safely is included in the SRS and SB section of this Service Manual.

#### **WARNING:**

- To avoid rendering the SRS inoperative, which could increase the risk of personal injury or death in the event of a collision which would result in air bag inflation, all maintenance must be performed by an authorized NISSAN/INFINITI dealer.
- Improper maintenance, including incorrect removal and installation of the SRS, can lead to personal injury caused by unintentional activation of the system. For removal of Spiral Cable and Air Bag Module, see the SRS section.
- Do not use electrical test equipment on any circuit related to the SRS unless instructed to in this Service Manual. SRS wiring harnesses can be identified by yellow and/or orange harnesses or harness connectors.

### Service Notice or Precautions

ECS001YG

- Use recommended brake fluid when adding fluid to the clutch reservoir tank. Refer to [MA-14, "RECOMMENDED FLUIDS AND LUBRICANTS"](#).
- Never reuse fluid drained from clutch system.
- Be careful not to splash brake fluid on painted areas.
- Use new brake fluid to clean or wash all parts of master cylinder and CSC (Concentric slave cylinder).
- Never use mineral oils such as gasoline or kerosene. It will ruin the rubber parts of the hydraulic system.
- If transaxle assembly is removed from the vehicle, always replace CSC. Return CSC to original position to remove transaxle assembly. Dust on clutch disc sliding parts may damage CSC seal and may cause clutch fluid leakage.
- Do not disassemble clutch master cylinder and CSC.

#### **WARNING:**

After cleaning clutch disc, clean it with a dust collector. Do not use compressed air.

# PREPARATION

## PREPARATION

PF0:00002

### Special Service Tools

ECS001YH

The actual shapes of Kent-Moore tools may differ from those of special service tools illustrated here.

Tool number (Kent-Moore No.) Tool name	Description
ST20050240 ( — ) Diaphragm spring adjusting wrench	Adjusting unevenness of diaphragm spring of clutch cover
KV30101000 ( — ) Clutch aligning bar	Installing clutch cover and clutch disc <b>a: 15.9 mm (0.626 in) dia.</b> <b>b: 19.8 mm (0.780 in) dia.</b>



ZZA0508D

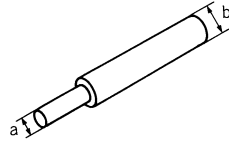

ZZA1178D

### Commercial Service Tools

ECS001YI

Tool name	Description
Power tool	Loosening bolts and nuts

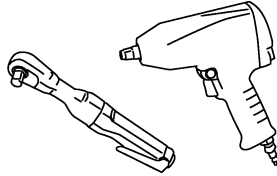

PBIC0190E

A  
B  
CL  
D  
E  
F  
G  
H  
I  
J  
K  
L  
M

# NOISE, VIBRATION AND HARSHNESS (NVH) TROUBLESHOOTING

## NOISE, VIBRATION AND HARSHNESS (NVH) TROUBLESHOOTING

PF0:00003

### NVH Troubleshooting Chart

ECS001YJ

Use the chart below to help you find the cause of the symptom. The numbers indicate the order of the inspection. If necessary, repair or replace these parts.

Reference page		<a href="#">CL-5</a>	<a href="#">CL-8</a>	<a href="#">EM-102</a>	<a href="#">CL-11</a>	<a href="#">CL-13</a>										<a href="#">EM-100</a>	
Symptom		CLUTCH PEDAL (Inspection and adjustment)	CLUTCH LINE (Air in line)	ENGINE MOUNTING (Loose)	CSC (Concentric slave cylinder) (Worn, dirty or damaged)	CLUTCH DISC (Out of true)	CLUTCH DISC (Runout is excessive)	CLUTCH DISC (Lining broken)	CLUTCH DISC (Dirty or burned)	CLUTCH DISC (Oily)	CLUTCH DISC (Worn out)	CLUTCH DISC (Hardened)	CLUTCH DISC (Lack of spline grease)	DIAPHRAGM SPRING (Damaged)	DIAPHRAGM SPRING (Out of tip alignment)	PRESSURE PLATE (Distortion)	FLYWHEEL (Distortion)
Symptom	Clutch grabs/chatters			1			2			2	2	2			2		
	Clutch pedal spongy		1														
	Clutch noisy				1												
	Clutch slips	1								2	2			3		4	5
	Clutch does not disengage	1	2			5	5	5	5	5			5	6	6	7	

# CLUTCH PEDAL

PFP:46540

## CLUTCH PEDAL

ECS001YK

### On-vehicle Inspection and Adjustment

1. Check to see if the master cylinder rod end moves freely. It should not be bound by the clutch pedal.
  - If the rod end does not move freely, remove the rod end and check for deformation or damage on the rod end. Leave the rod end removed for step 2.

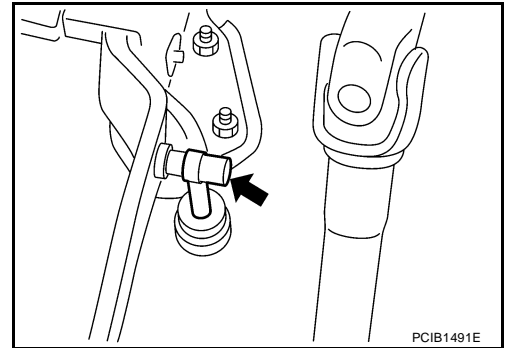

2. Check the clutch pedal stroke for free range of movement.
  - a. With the master cylinder rod end removed, manually move the pedal up and down to determine if it moves freely.
  - b. If any sticking is noted, replace the clutch pedal assembly. Re-verify that the master cylinder rod end moves freely.
3. Inspect the ASCD switch position (if equipped).
  - a. If the rod end does not move freely, check that the ASCD switch is not applying pressure to the clutch pedal causing the rod end to bind. To adjust, disconnect the ASCD switch electrical connector and turn the ASCD switch.
  - b. Connect the ASCD switch electrical connector.
4. Adjust clutch interlock switch (1) position so that clearance between clutch pedal (2) and thread end of clutch interlock switch (1), with clutch pedal fully depressed, is within specification (C).

**Clearance C : 0.74 - 1.96 mm (0.0291 - 0.0772 in)**

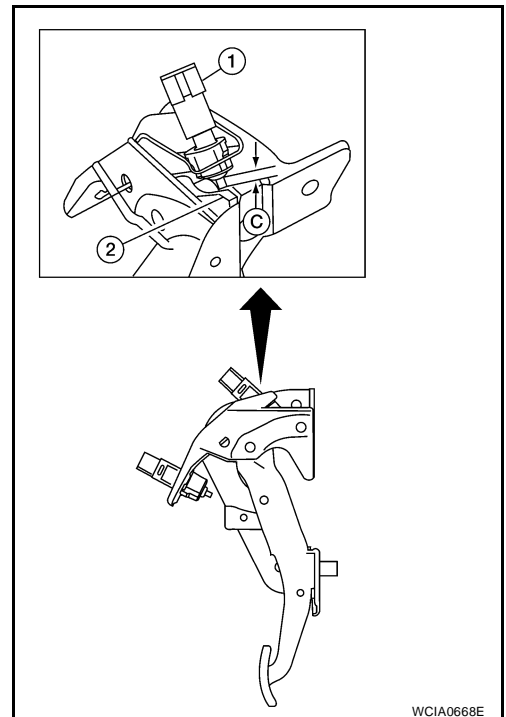

# CLUTCH PEDAL

5. Adjust ASCD clutch switch (1) position so that clearance between clutch pedal (2) and thread end of ASCD clutch switch (1), with clutch pedal fully released, is within specification (A) (if equipped).

**Clearance A : 0.74 - 1.96 mm (0.0291 - 0.0772 in)**

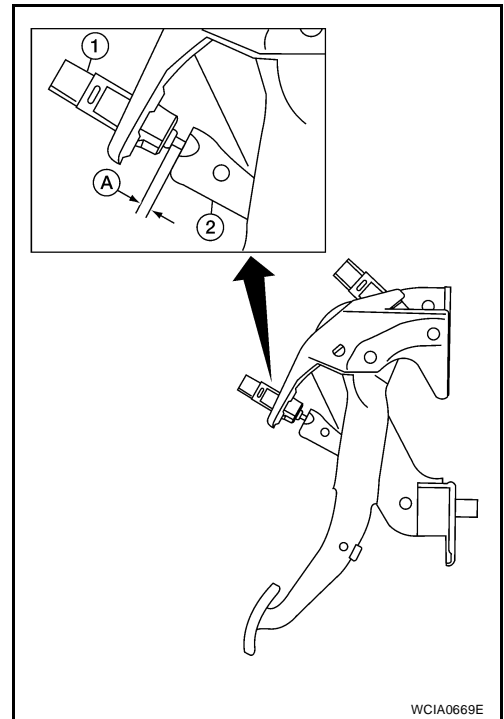

6. Check the clutch hydraulic system components (clutch master cylinder, CSC (Concentric slave cylinder), clutch damper) for sticking or binding.
  - a. If any sticking or binding is noted, repair or replace the related parts as necessary.
  - b. If any hydraulic system repair was necessary, bleed the clutch hydraulic system. Refer to [CL-8, "Air Bleeding Procedure"](#).

**NOTE:**

Do not use a vacuum assist or any other type of power bleeder on this system. Use of a vacuum assist or power bleeder will not purge all of the air from the system.

# CLUTCH PEDAL

ECS001YL

## Removal and Installation COMPONENTS

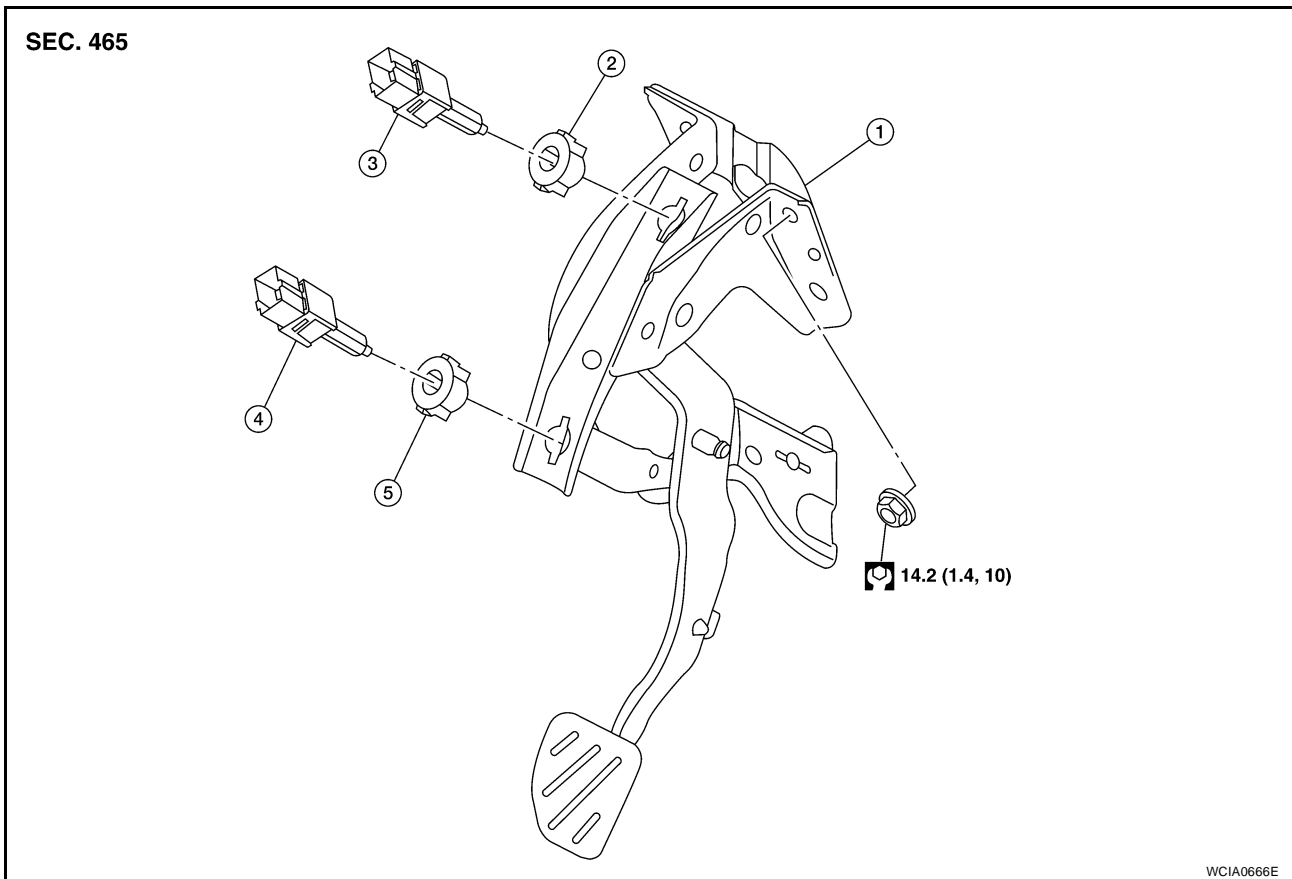

- |                                     |             |                            |
|-------------------------------------|-------------|----------------------------|
| 1. Clutch pedal assembly            | 2. Lock nut | 3. Clutch interlock switch |
| 4. ASCD clutch switch (if equipped) | 5. Lock nut |                            |

### REMOVAL

1. Remove instrument panel lower finisher. Refer to [IP-17, "INSTRUMENT LOWER FINISHER"](#) .
2. Remove front upper floor duct. Refer to [MTC-88, "DUCTS AND GRILLES"](#) .
3. Disconnect ASCD clutch switch harness connector (if equipped).
4. Disconnect master cylinder rod end from clutch pedal lever.
5. Remove clutch pedal assembly nuts, and then remove clutch pedal assembly.
6. Disconnect clutch interlock switch harness connector.

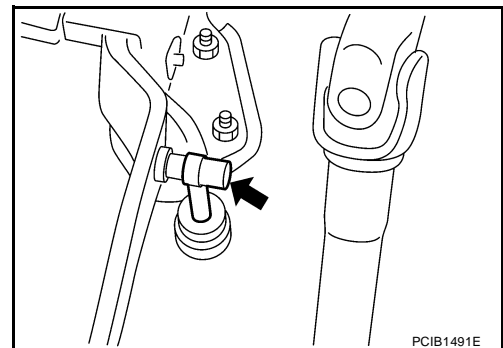

### INSPECTION AFTER REMOVAL

Check clutch pedal for bend, damage or a cracked weld. If bend, damage or a cracked weld is found, replace clutch pedal assembly.

### INSTALLATION

Installation is in the reverse order of removal.

- After installing the clutch switches, adjust the switch positions. Refer to [CL-5, "On-vehicle Inspection and Adjustment"](#) .

# CLUTCH FLUID

## CLUTCH FLUID

PF0:00017

### Air Bleeding Procedure

ECS001YM

#### CAUTION:

- Do not spill clutch fluid onto painted surfaces. If it spills, wipe up immediately and wash the affected area with water.

#### NOTE:

- Do not use a vacuum assist or any other type of power bleeder on this system. Use of a vacuum assist or power bleeder will not purge all the air from the system.
  - Carefully monitor fluid level in reservoir tank during bleeding operation.
1. Fill master cylinder reservoir tank with new clutch fluid.
  2. Connect a transparent vinyl tube and container to the CSC (Concentric slave cylinder) connector air bleed port (1).
  3. Fully depress the clutch pedal several times.

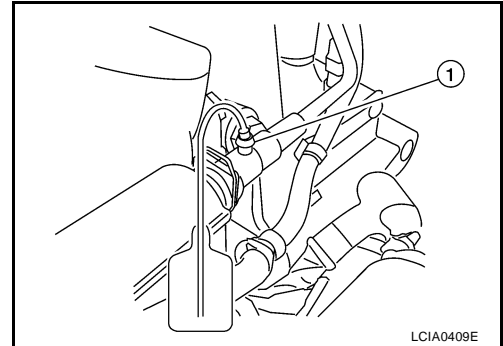

4. With clutch pedal depressed, push the lock pin (1) of the CSC (Concentric slave cylinder) connector (2) as shown.

#### CAUTION:

Hold the lock pin in to prevent the connector from separating.

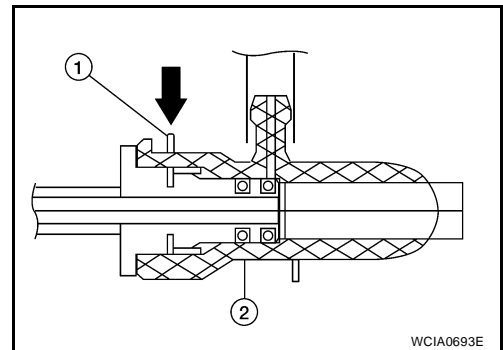

5. Slide the CSC (Concentric slave cylinder) connector (1) as shown to bleed the air.

**Dimension A : 5 mm (0.20 in)**

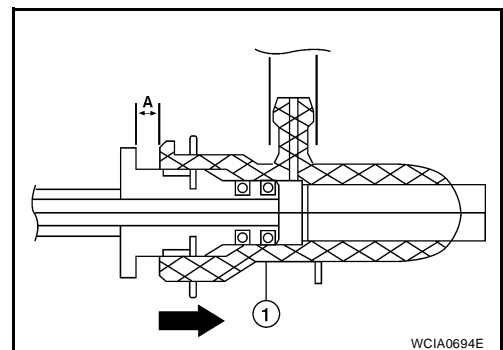

6. Return the CCS (Concentric slave cylinder) connector and lock pin to their original positions.
7. Release clutch pedal and wait for 5 seconds.
8. Repeat steps 2 to 7 until no bubbles are observed in the clutch fluid.



# CLUTCH MASTER CYLINDER

PF3:30610

ECS001YN

## CLUTCH MASTER CYLINDER

### Removal and Installation

#### REMOVAL

1. Remove the battery. Refer to [SC-7, "Removal and Installation MR20DE"](#).
2. Remove the air cleaner and air duct. Refer to [EM-18, "Removal and Installation"](#).
3. Use one of the following methods to remove hose from master cylinder.
  - Drain clutch fluid from reservoir tank and remove hose.
  - Remove hose from master cylinder. Immediately plug hose and reservoir tank to prevent clutch fluid from dripping.

#### CAUTION:

**Do not spill clutch fluid onto painted surfaces. If it spills, wipe up immediately and wash the affected area with water.**

4. Remove master cylinder rod end from clutch pedal assembly.

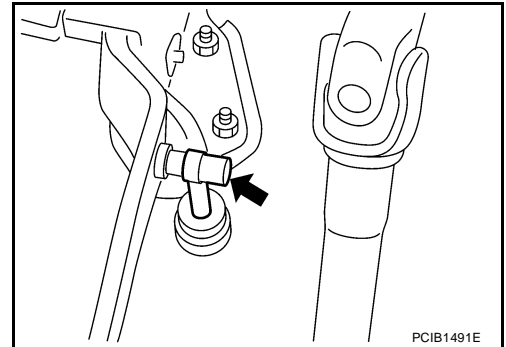

5. Remove lock pin (1) from connector of master cylinder (2) and separate clutch tube (3).

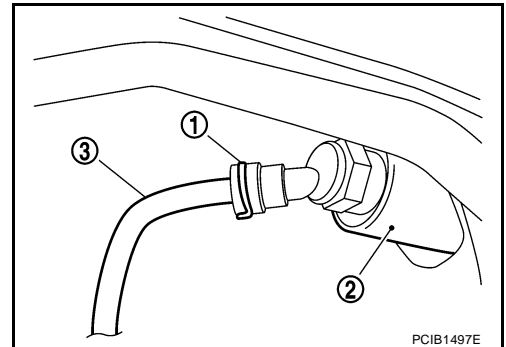

6. Rotate master cylinder clockwise by 45° and remove from the vehicle.

#### INSTALLATION

1. Tilt master cylinder clockwise by 45° and insert it in the mounting hole. Rotate counterclockwise to secure it. At this time, nipple is in the up position.
2. Install master cylinder rod end to clutch pedal.

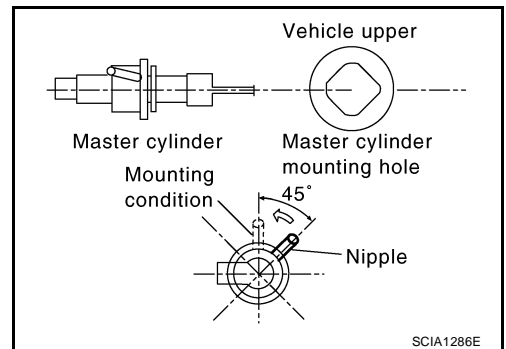

## CLUTCH MASTER CYLINDER

3. Install clutch tube (1) fully into connector of master cylinder (2).
4. Install lock pin (3) fully into connector of master cylinder (2).
5. Fill with new clutch fluid and bleed air from the system. Refer to [CL-8, "Air Bleeding Procedure"](#).
6. After completing this procedure, inspect clutch pedal operation. Refer to [CL-5, "On-vehicle Inspection and Adjustment"](#).
7. Install the air cleaner and air duct. Refer to [EM-18, "Removal and Installation"](#).
8. Install the battery. Refer to [SC-7, "Removal and Installation MR20DE"](#).

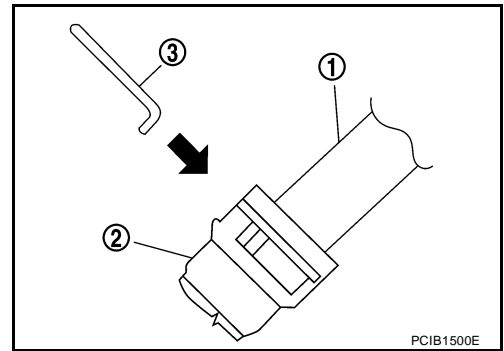

# CSC (CONCENTRIC SLAVE CYLINDER)

## CSC (CONCENTRIC SLAVE CYLINDER)

PF3:30500

### Removal and Installation

ECS001Y0

#### CAUTION:

- If transaxle assembly is removed from the vehicle, always replace CSC (Concentric slave cylinder). Return CSC insert to original position to remove transaxle assembly. Dust on clutch disc sliding parts may damage CSC seal and may cause clutch fluid leakage.
- Do not spill clutch fluid onto painted surfaces. If it spills, wipe up immediately and wash the affected area with water.

#### REMOVAL

1. Remove transaxle assembly. Refer to [MT-17, "Removal and Installation"](#) (MR20DE), [MT-66, "Removal and Installation"](#), [MT-142, "Removal and Installation"](#) (QR25DE).
2. Remove CSC bolts and the CSC from clutch housing.

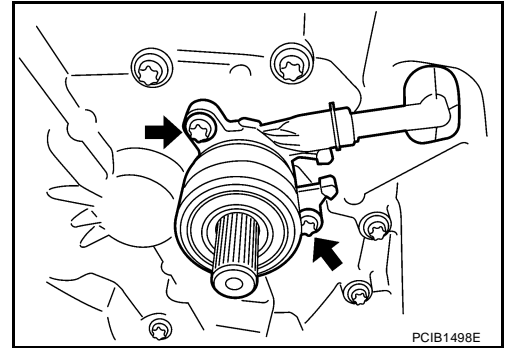

#### INSTALLATION

1. Install CSC to clutch housing and then tighten bolts to specification. Refer to [MT-19, "Case and Housing Components"](#) (MR20DE), [MT-68, "Case and Housing Components"](#), [MT-144, "Case and Housing Components"](#) (QR25DE).

#### CAUTION:

- Do not reuse CSC.
  - Do not insert and operate CSC because piston and stopper of CSC components may fall off.
2. Install transaxle assembly. Refer to [MT-17, "Removal and Installation"](#) (MR20DE), [MT-66, "Removal and Installation"](#), [MT-142, "Removal and Installation"](#) (QR25DE).
  3. Bleed the air from the clutch hydraulic system. Refer to [CL-8, "Air Bleeding Procedure"](#).

# CLUTCH PIPING

PF3:30650

## CLUTCH PIPING

### Removal and Installation

ECS001YP

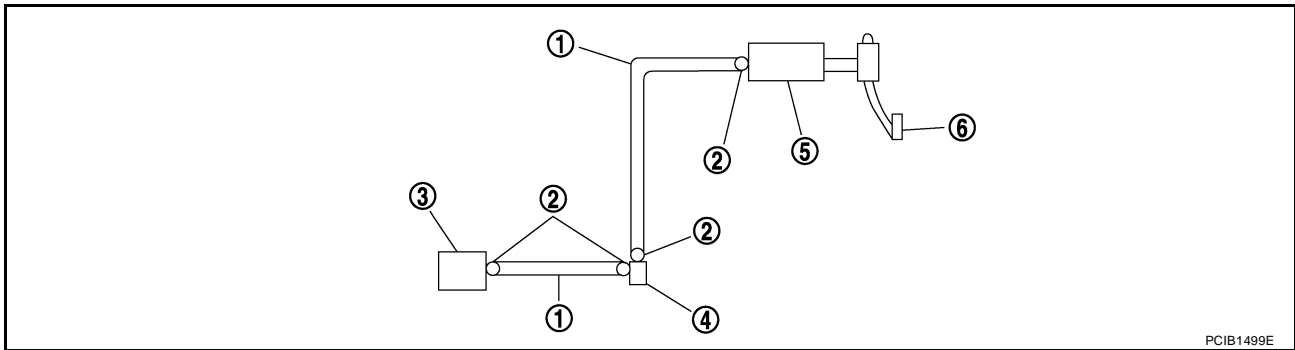

PCIB1499E

- |                  |                           |                 |
|------------------|---------------------------|-----------------|
| 1. Clutch tube   | 2. Clutch tube lock pin   | 3. CSC          |
| 4. Clutch damper | 5. Clutch master cylinder | 6. Clutch pedal |

Carefully observe the following steps during clutch tube removal and installation.

#### CAUTION:

**Do not spill clutch fluid onto painted surfaces. If it spills, wipe up immediately and wash the affected area with water.**

#### REMOVAL

1. Remove the battery. Refer to [SC-7, "Removal and Installation MR20DE"](#) .
2. Remove the air cleaner and air duct. Refer to [EM-18, "Removal and Installation"](#) .
3. Remove clutch tube lock pin from clutch master cylinder, if necessary.
4. Remove clutch tube lock pin at clutch housing, if necessary.
5. Remove clutch tube lock pins (2) from clutch damper (3).
6. Remove clutch tubes (1) from clutch damper (3).
7. Remove clutch damper (3) from bracket (4).

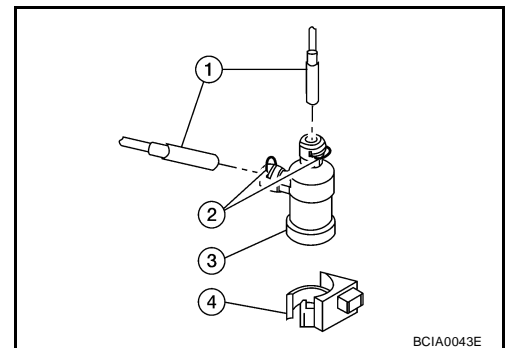

BCIA0043E

#### INSTALLATION

Installation is in the reverse order of removal.

- **Make sure that all tubes are fully installed into connectors.**
- **Make sure that all connector lock pins are fully installed.**
- After installation, bleed the air from the clutch hydraulic system. Refer to [CL-8, "Air Bleeding Procedure"](#) .

# CLUTCH DISC, CLUTCH COVER AND FLYWHEEL

## CLUTCH DISC, CLUTCH COVER AND FLYWHEEL

PF3:30100

### Removal and Installation COMPONENTS

ECS001YQ

#### MR20DE Models

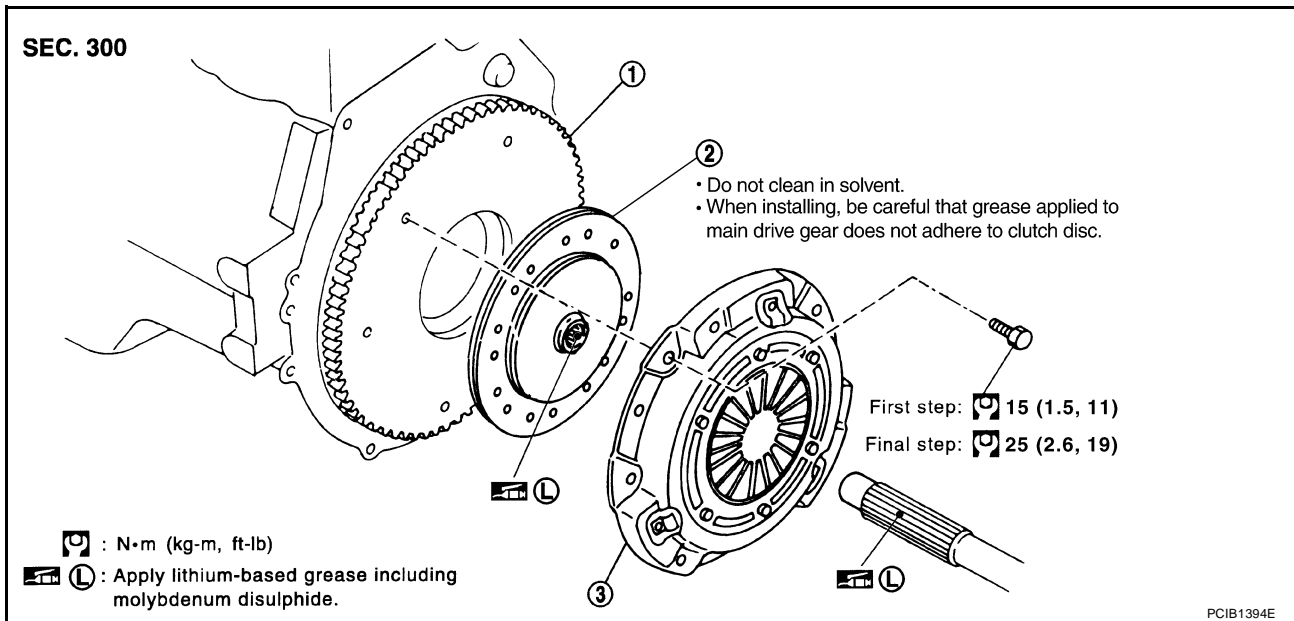

1. Flywheel

2. Clutch disc

3. Clutch cover

#### QR25DE Models

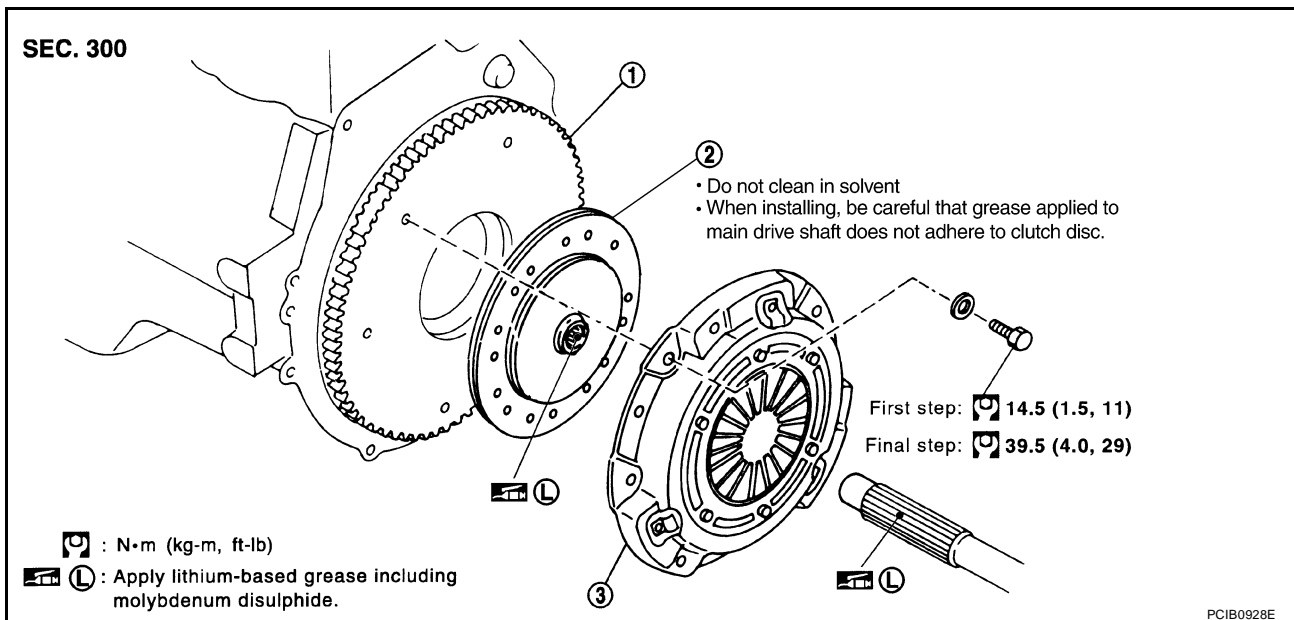

1. Flywheel

2. Clutch disc

3. Clutch cover

#### CAUTION:

- If transaxle assembly is removed from the vehicle, always replace CSC (Concentric slave cylinder). Return CSC insert to original position to remove transaxle assembly. Dust on clutch disc sliding parts may damage CSC seal and may cause clutch fluid leakage.
- Be careful not to apply any grease to the clutch disc facing, pressure plate surface and flywheel surface.

#### REMOVAL

1. Remove transaxle assembly from the vehicle. Refer to [MT-17, "Removal and Installation"](#) (MR20DE), [MT-66, "Removal and Installation"](#), [MT-142, "Removal and Installation"](#) (QR25DE).

# CLUTCH DISC, CLUTCH COVER AND FLYWHEEL

2. Loosen clutch cover bolts evenly. Then remove clutch cover and clutch disc.

## INSPECTION AND ADJUSTMENT AFTER REMOVAL

### Clutch Disc

- Check clutch disc for backlash of spline and runout of facing.

**Maximum facing runout**      **MR20DE : 1.0 mm (0.039 in)**  
                                          **QR25DE : 0.7 mm (0.028 in)**

**Distance of runout check point (from hub center)**      **MR20DE : 215 mm (8.46 in)**  
                                          **QR25DE : 230 mm (9.06 in)**

- Check clutch disc for burns, discoloration or oil or grease leakage. Replace if necessary.
- Measure backlash to clutch disc spline and input shaft spline at the circumference of clutch disc. If outside the specification, replace clutch disc.

**Maximum allowable spline backlash : 1.0 mm (0.039 in)**  
**(at outer edge of disc)**

- Use a suitable tool to measure the depth to clutch disc facing rivet heads. If it exceeds the allowable wear limit, replace clutch disc.

**Wear limit of facing surface to rivet head**      **: 0.3 mm (0.012 in)**

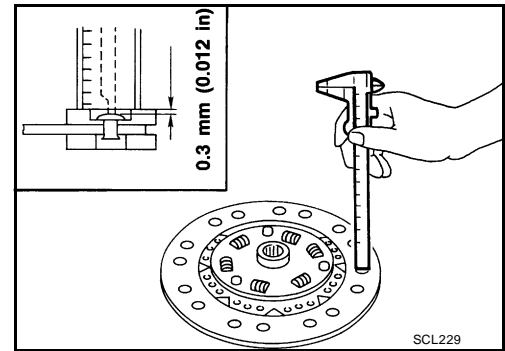
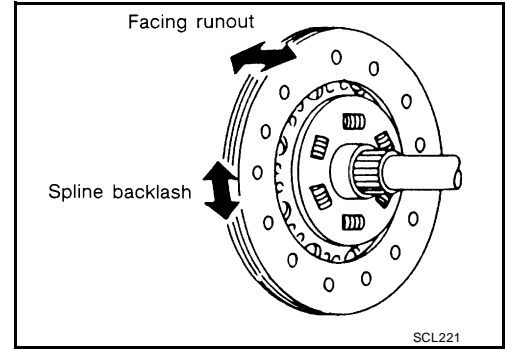

### Clutch Cover

Check clutch cover installed on vehicle for unevenness of diaphragm spring toe height.

**Uneven limit : 0.7 mm (0.028 in) or less**

**Tool number A : ST20050240 ( — )**

- If out of limit, adjust the height using Tool (A).
- Check clutch cover thrust ring for wear or breakage. If wear or breakage is found, replace clutch cover assembly.

#### NOTE:

- Worn thrust ring will generate a beating noise when tapped at the rivet with a suitable tool.
- Broken thrust ring will make a clinking sound when cover is shaken up and down.
- If a trace of burn or discoloration is found on the clutch cover pressure plate to clutch disc contact surface, repair the surface with sandpaper. If surface is damaged or distorted, replace the assembly.

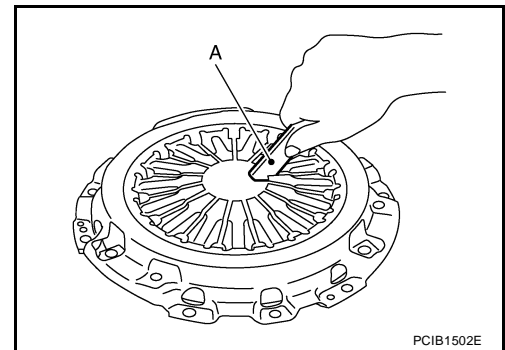

# CLUTCH DISC, CLUTCH COVER AND FLYWHEEL

## Flywheel Runout

- Check contact surface of flywheel for slight burns or discoloration. Repair flywheel with emery paper.
- Check the flywheel runout. Refer to [EM-100, "FLYWHEEL DEFLECTION \(M/T MODELS\)"](#) (MR20DE), [EM-206, "Flywheel Deflection"](#) (QR25DE).

### CAUTION:

Measure flywheel outer face (not on knock pin and clutch cover mounting hole).

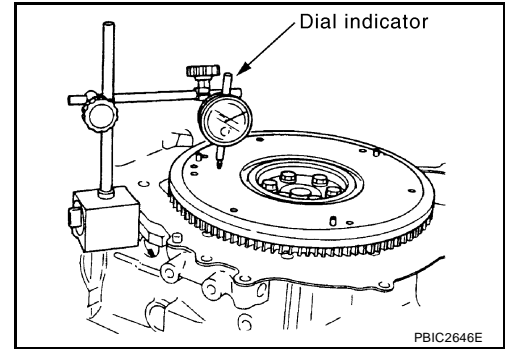

## INSTALLATION

1. Clean clutch disc and input shaft splines to remove grease and dust caused by abrasion.
2. Apply recommended grease to clutch disc and input shaft splines.

### CAUTION:

Be sure to apply grease to the points specified. Otherwise, noise, poor disengagement, or damage to the clutch may result. Excessive grease may cause slip or shudder. If it adheres to CSC seal, it will cause clutch fluid leakage. Wipe off excess grease.

3. Install clutch disc using tool.

**Tool number** : KV30101000 ( — )

4. Install clutch cover. Pre-tighten clutch cover bolts.
5. Tighten clutch cover bolts evenly in two steps in the order shown. Refer to [CL-13, "COMPONENTS"](#).
6. Install transaxle assembly. Refer to [MT-17, "Removal and Installation"](#) (MR20DE), [MT-66, "Removal and Installation"](#), [MT-142, "Removal and Installation"](#) (QR25DE).

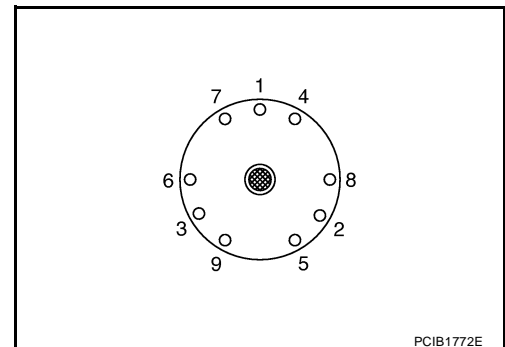

A  
B  
CL  
D  
E  
F  
G  
H  
I  
J  
K  
L  
M

# SERVICE DATA AND SPECIFICATIONS (SDS)

## SERVICE DATA AND SPECIFICATIONS (SDS)

PF:00030

### Clutch Control System

ECS001YR

Type of clutch control	Hydraulic
------------------------	-----------

### Clutch Pedal

ECS001YS

Clearance "A" between clutch pedal and ASCD switch threaded end while clutch pedal is fully released (if equipped).	0.74 - 1.96 mm (0.0291 - 0.0772 in)
Clearance "C" between clutch pedal and clutch interlock switch threaded end while clutch pedal is fully depressed.	0.74 - 1.96 mm (0.0291 - 0.0772 in)

### Clutch Disc

ECS001YT

Engine	MR20DE	QR25DE
Model	225	240
Facing size (outer dia. × inner dia. × thickness)	225 mm × 160 mm × 3.2 mm (8.86 in × 6.30 in × 0.126 in)	240 mm × 160 mm × 3.2 mm (9.45 in × 6.30 in × 0.126 in)
Thickness of disc assembly with load	7.2 - 7.6 mm (0.283 - 0.299 in) with 5,394 N (550 kg, 1,213 lb)	7.15 - 7.65 mm (0.281 - 0.301 in) with 6,370 N (649.7 kg, 1,432 lb)
Runout limit/diameter of the area to be measured	1.0 mm (0.039 in) / 215 mm (8.46 in) dia.	0.7 mm (0.028 in) / 230 mm (9.06 in) dia.
Maximum spline backlash (at outer edge of disc)	1.0 mm (0.039 in)	
Wear limit of facing surface to rivet head	0.3 mm (0.012 in)	

### Clutch Cover

ECS001YU

Engine	MR20DE	QR25DE
Set-load	5,394 N (550 kg, 1,213 lb)	6,370 N (649.7 kg, 1,432 lb)
Diaphragm spring lever height	20 - 22 mm (0.79 - 0.87 in)	28.6 - 30.6 mm (1.126 - 1.205 in)
Uneven limit diaphragm spring toe height	0.7 mm (0.028 in) or less	