

SECTION **PG**

POWER SUPPLY, GROUND & CIRCUIT ELEMENTS

CONTENTS

PRECAUTIONS	2	BODY HARNESS	35	F
Precautions for Supplemental Restraint System (SRS) "AIR BAG" and "SEAT BELT PRE-TENSIONER"	2	ROOM LAMP HARNESS	37	G
POWER SUPPLY ROUTING	3	FRONT DOOR HARNESS	38	H
Schematic	3	REAR DOOR HARNESS	39	I
Wiring Diagram — POWER —	5	Wiring Diagram Codes (Cell Codes)	40	J
BATTERY POWER SUPPLY — IGNITION SW. IN ANY POSITION	5	ELECTRICAL UNITS LOCATION	43	A
ACCESSORY POWER SUPPLY — IGNITION SW. IN "ACC" OR "ON"	8	Electrical Units Location	43	B
IGNITION POWER SUPPLY — IGNITION SW. IN "ON"	9	ENGINE COMPARTMENT	43	C
IGNITION POWER SUPPLY — IGNITION SW. IN "ON" AND/OR "START"	10	PASSENGER COMPARTMENT	44	D
GROUND	13	Fuse	46	E
Ground Distribution	13	Fusible Link	46	F
MAIN HARNESS	13	Circuit Breaker	46	G
ENGINE ROOM HARNESS	15	HARNESS CONNECTOR	47	H
ENGINE CONTROL HARNESS	17	Description	47	I
BODY HARNESS	19	HARNESS CONNECTOR (TAB-LOCKING TYPE)	47	J
REAR WINDOW DEFOGGER GROUND HARNESS	20	HARNESS CONNECTOR (SLIDE-LOCKING TYPE)	48	PG
ROOM HARNESS	21	HARNESS CONNECTOR (DIRECT-CONNECT SRS COMPONENT TYPE)	49	L
HARNESS	22	ELECTRICAL UNITS	50	M
Harness Layout	22	Terminal Arrangement	50	
HOW TO READ HARNESS LAYOUT	22	STANDARDIZED RELAY	51	
OUTLINE	23	Description	51	
MAIN HARNESS	24	NORMAL OPEN, NORMAL CLOSED AND MIXED TYPE RELAYS	51	
ENGINE ROOM HARNESS	26	TYPE OF STANDARDIZED RELAYS	51	
ENGINE CONTROL HARNESS	29	FUSE BLOCK — JUNCTION BOX (J/B)	53	
		Terminal Arrangement	53	
		FUSE AND FUSIBLE LINK BOX	54	
		Terminal Arrangement	54	

PRECAUTIONS

PRECAUTIONS

PF0:00001

Precautions for Supplemental Restraint System (SRS) “AIR BAG” and “SEAT BELT PRE-TENSIONER”

EKS00658

The Supplemental Restraint System such as “AIR BAG” and “SEAT BELT PRE-TENSIONER”, used along with a front seat belt, helps to reduce the risk or severity of injury to the driver and front passenger for certain types of collision. Information necessary to service the system safely is included in the SRS and SB section of this Service Manual.

WARNING:

- To avoid rendering the SRS inoperative, which could increase the risk of personal injury or death in the event of a collision which would result in air bag inflation, all maintenance must be performed by an authorized NISSAN/INFINITI dealer.
- Improper maintenance, including incorrect removal and installation of the SRS, can lead to personal injury caused by unintentional activation of the system. For removal of Spiral Cable and Air Bag Module, see the SRS section.
- Do not use electrical test equipment on any circuit related to the SRS unless instructed to in this Service Manual. SRS wiring harnesses can be identified by yellow and/or orange harnesses or harness connectors.

POWER SUPPLY ROUTING

POWER SUPPLY ROUTING

Schematic

For detailed ground distribution information, refer to [PG-13, "Ground Distribution"](#).

PF2:24110

EKS003AZ

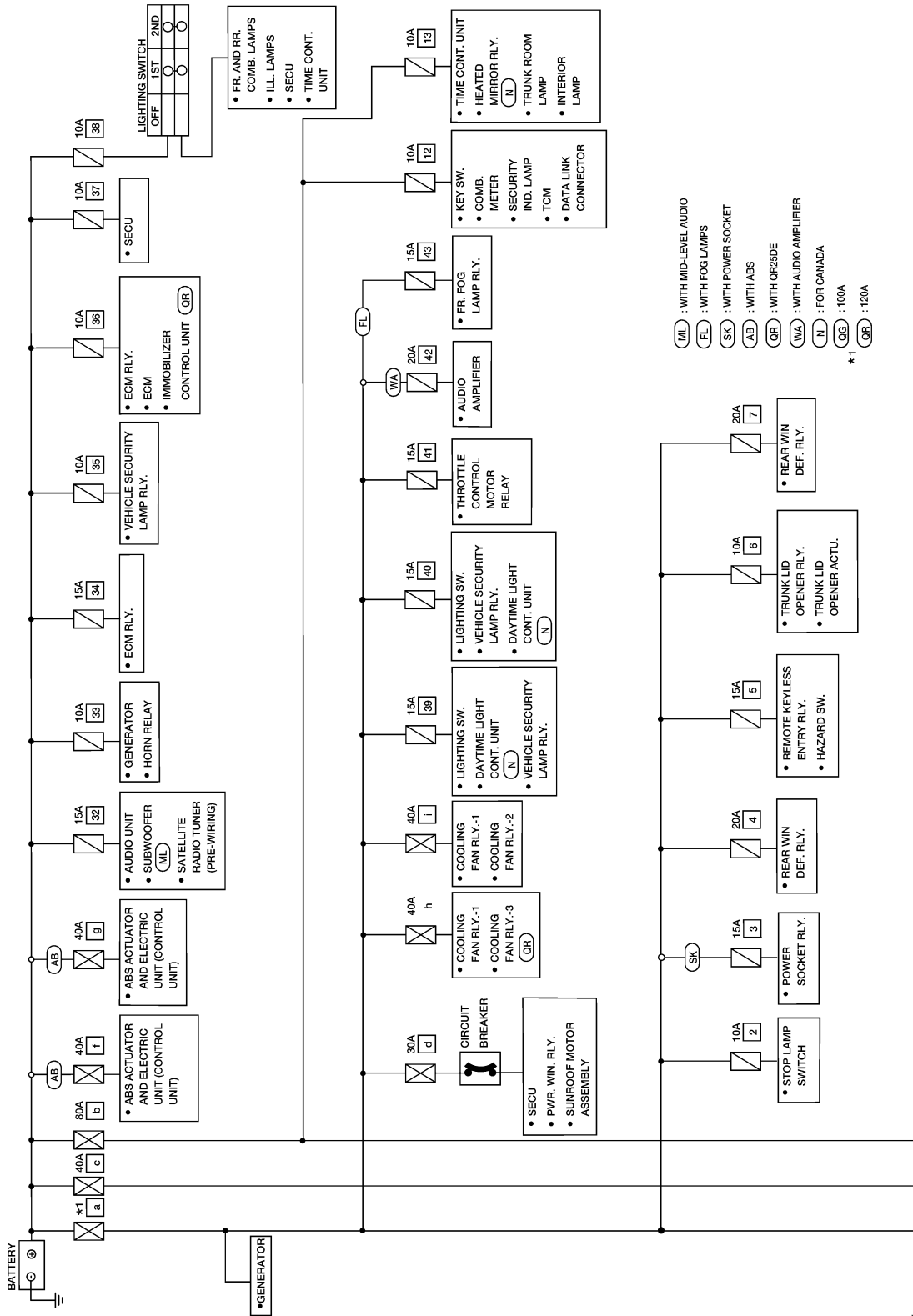

WKWA2088E

A
B
C
D
E
F
G
H
I
J
K
L
M
PG

POWER SUPPLY ROUTING

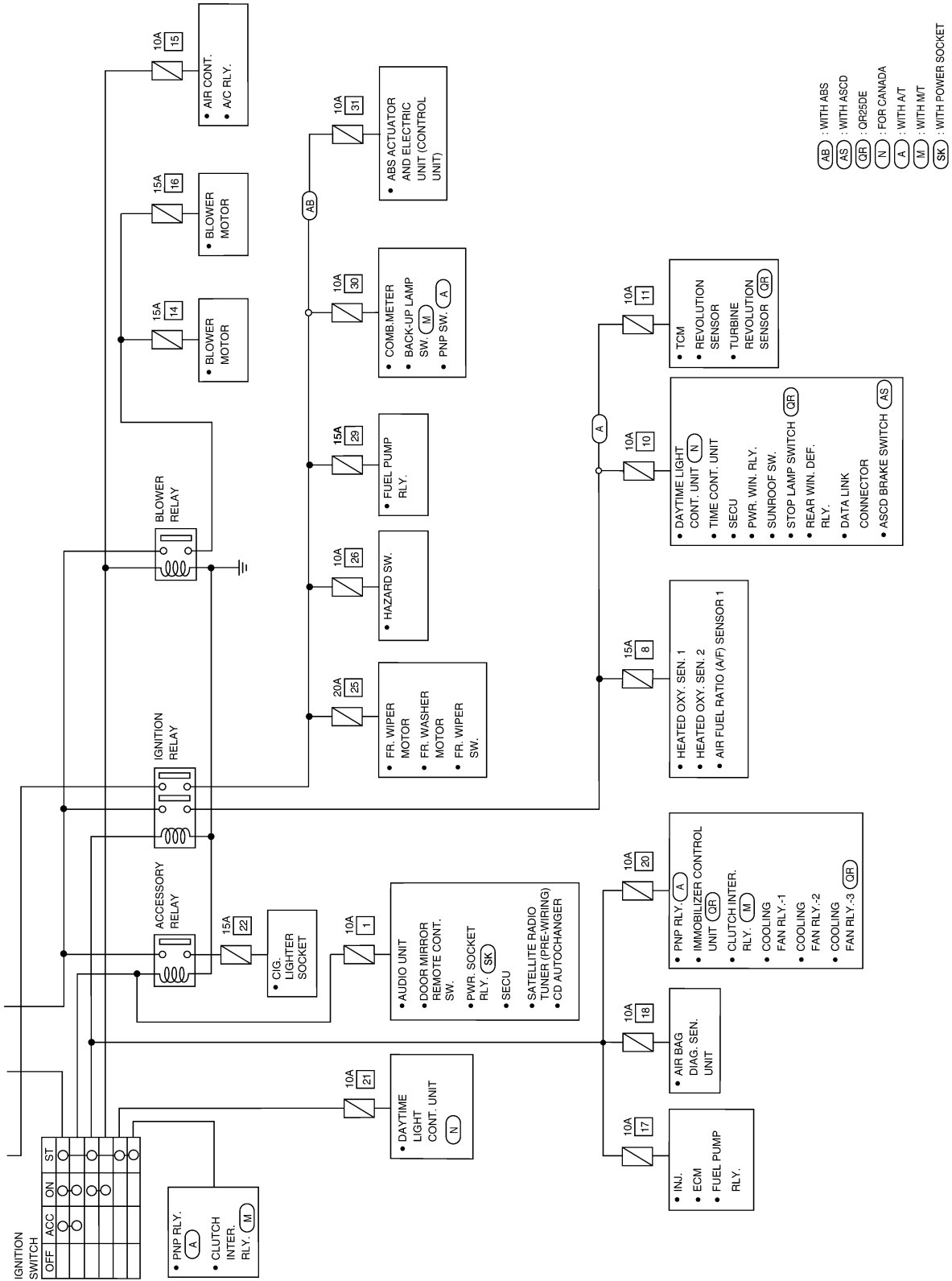

POWER SUPPLY ROUTING

EKS003B0

Wiring Diagram — POWER — BATTERY POWER SUPPLY — IGNITION SW. IN ANY POSITION

PG-POWER-01

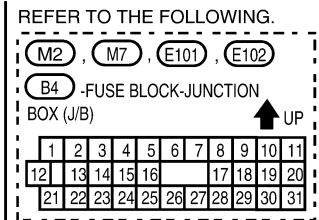
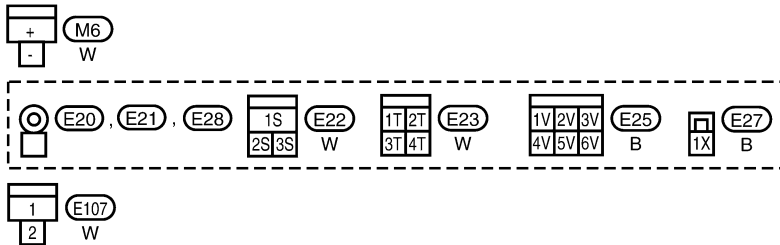
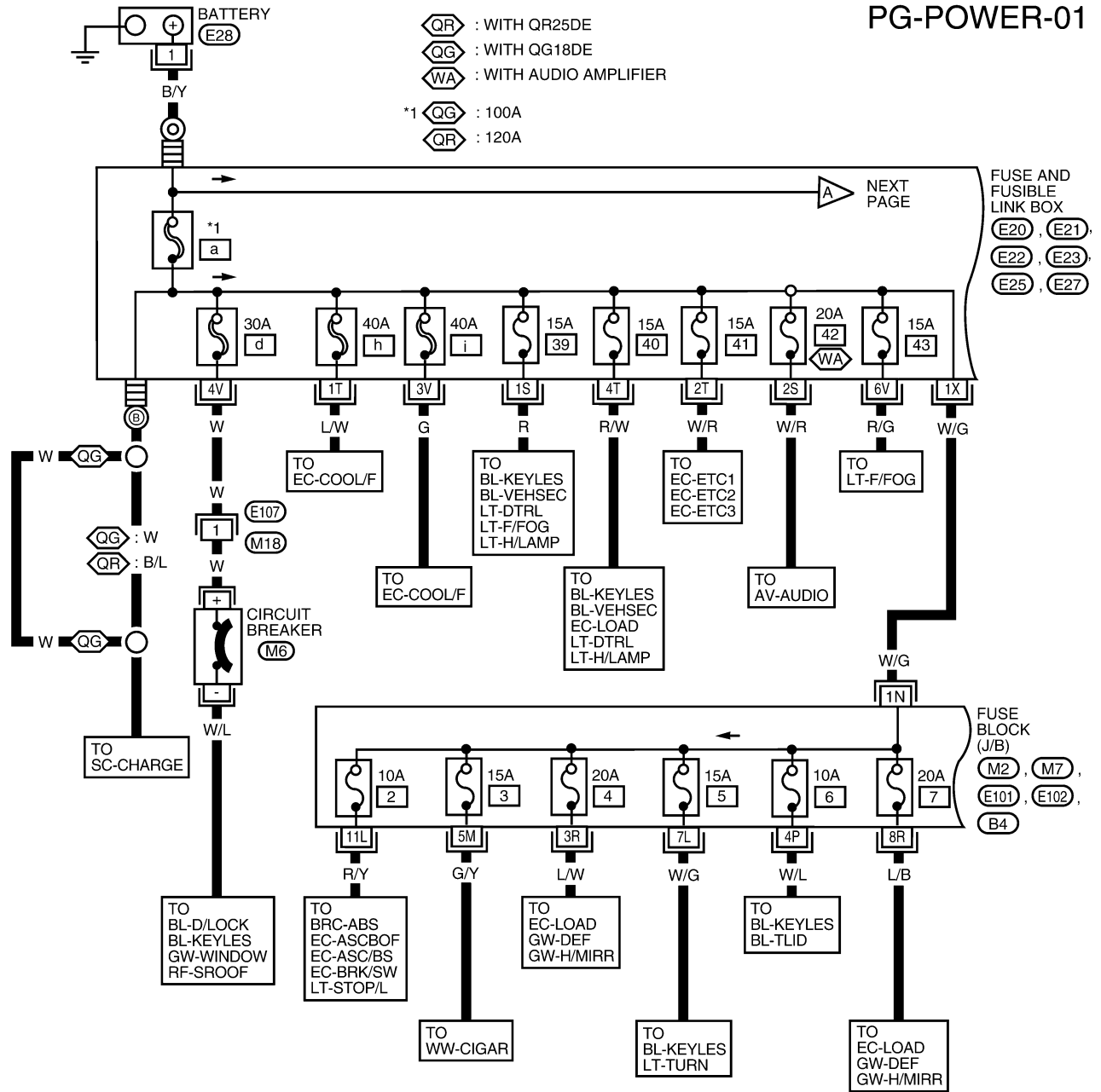

WKWA0491E

POWER SUPPLY ROUTING

PG-POWER-02

⬡AB⬢ : WITH ABS

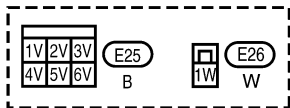
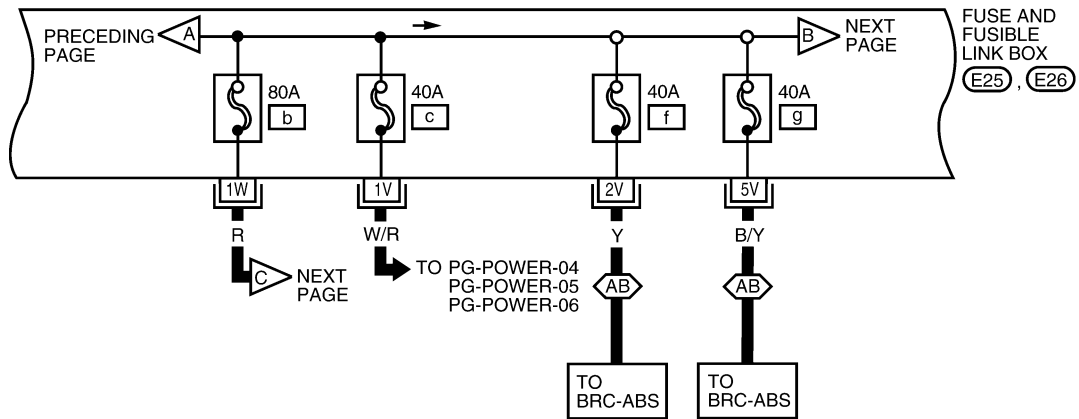

WKWA0057E

POWER SUPPLY ROUTING

PG-POWER-03

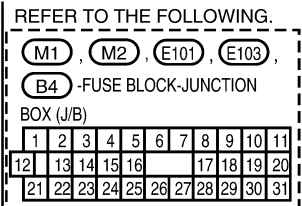
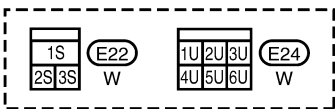
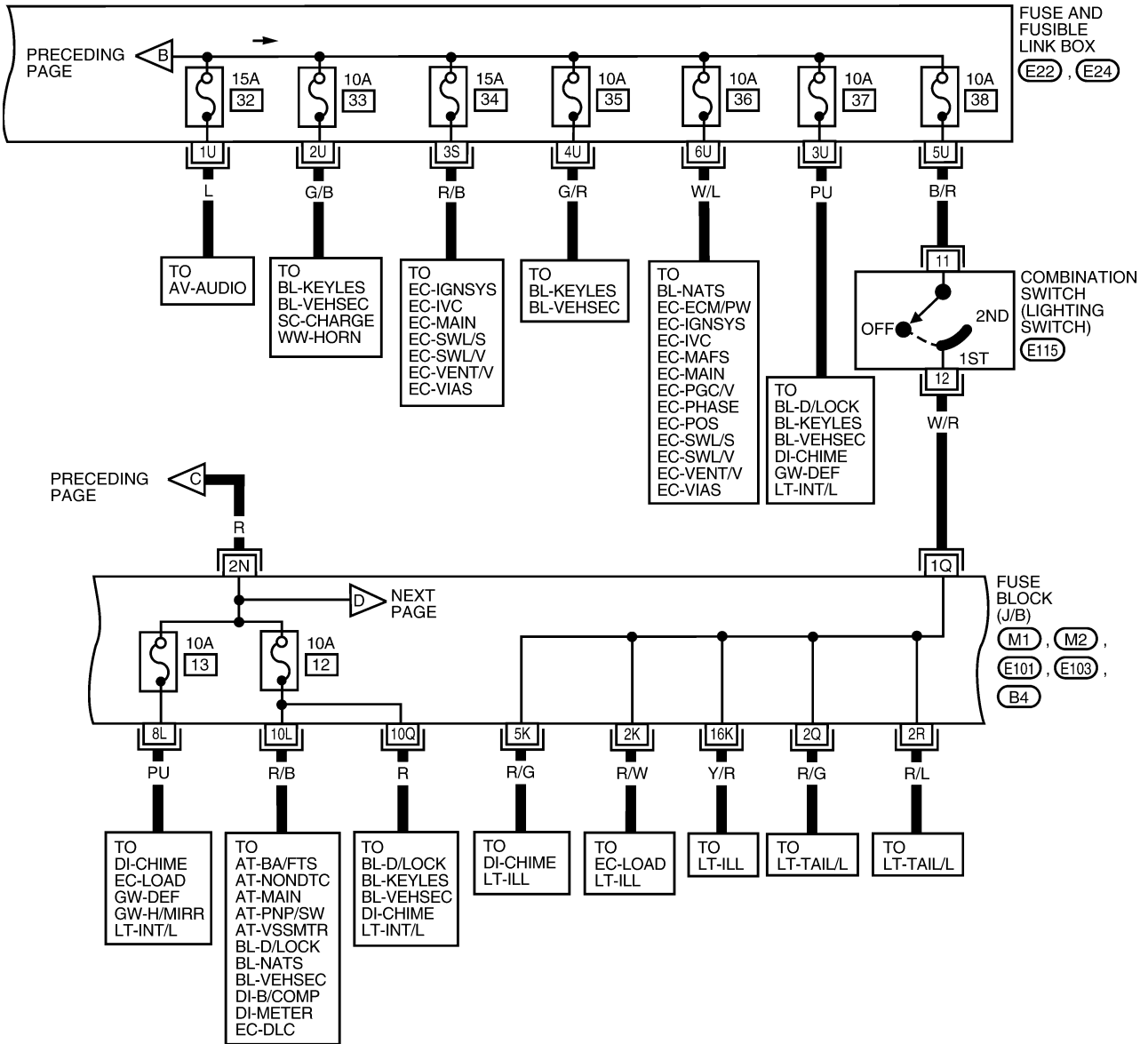

POWER SUPPLY ROUTING

ACCESSORY POWER SUPPLY — IGNITION SW. IN “ACC” OR “ON”

PG-POWER-04

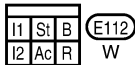
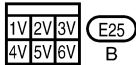
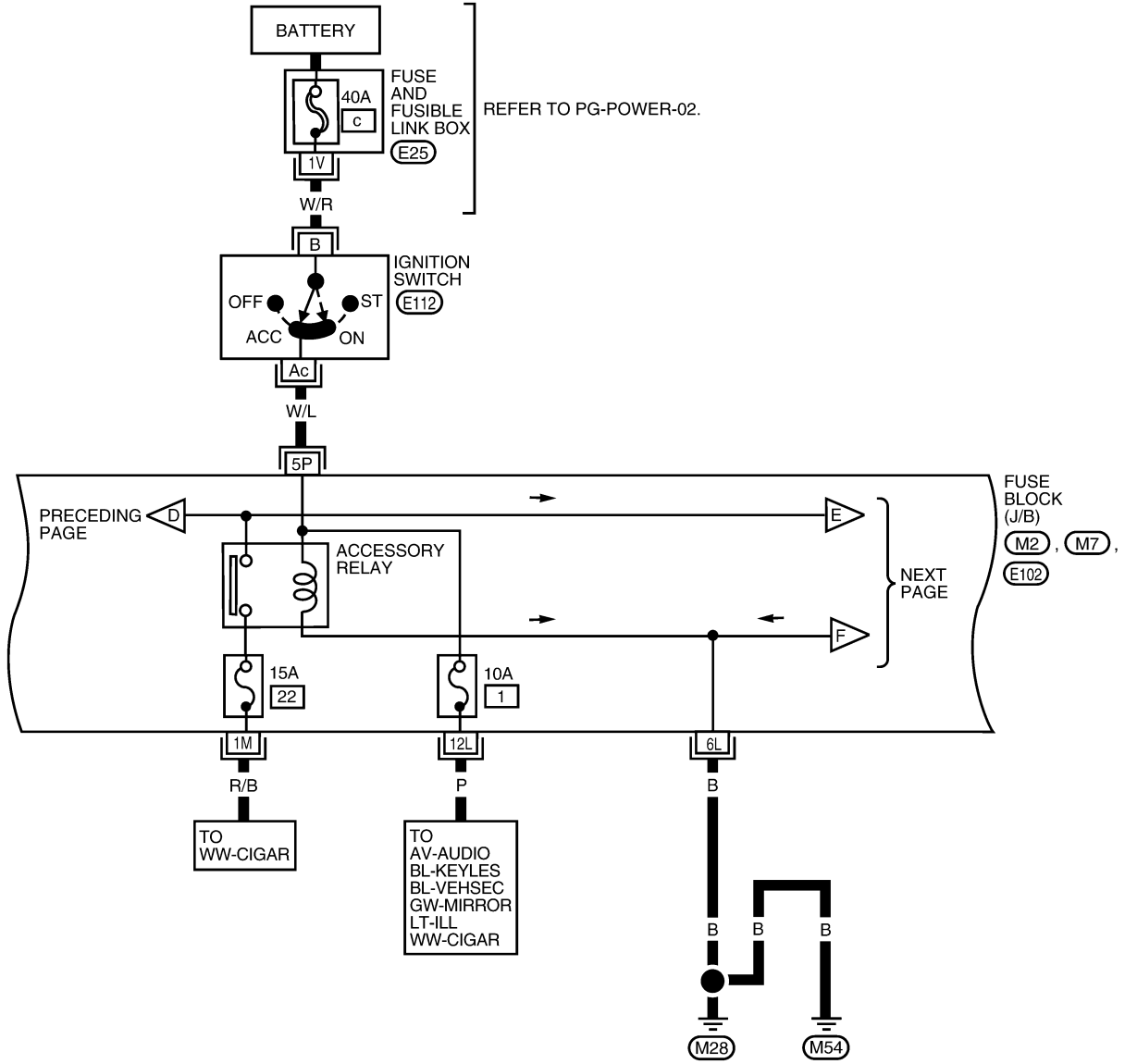

REFER TO THE FOLLOWING.

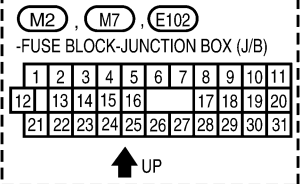

WKWA2091E

POWER SUPPLY ROUTING

IGNITION POWER SUPPLY — IGNITION SW. IN “ON”

PG-POWER-05

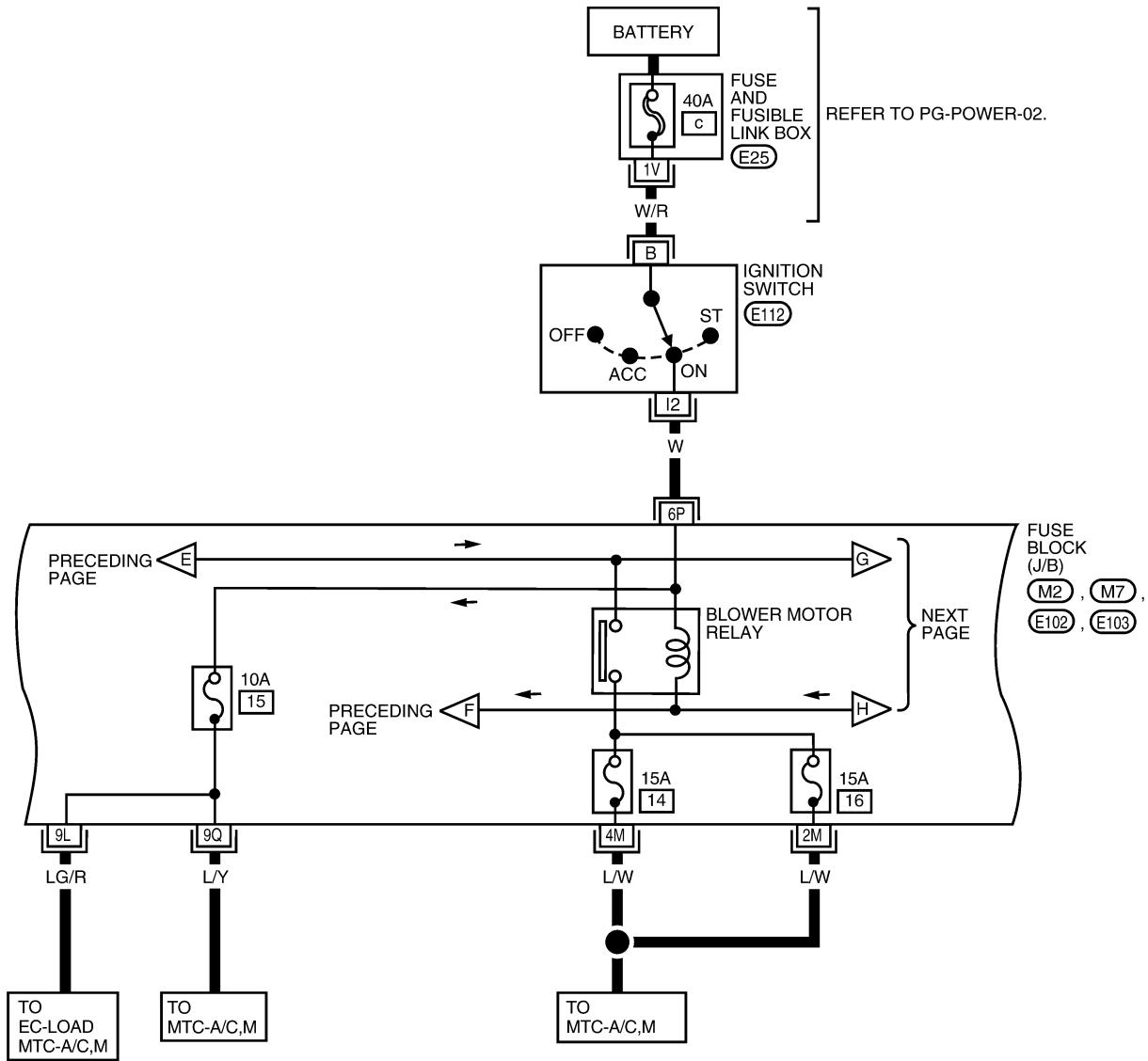

REFER TO THE FOLLOWING.

(M2), (M7), (E102), (E103)

- FUSE BLOCK-JUNCTION BOX (J/B)

1	2	3	4	5	6	7	8	9	10	11
12	13	14	15	16		17	18	19	20	
21	22	23	24	25	26	27	28	29	30	31

↑ UP

WKWA2092E

POWER SUPPLY ROUTING

IGNITION POWER SUPPLY — IGNITION SW. IN “ON” AND/OR “START”

PG-POWER-06

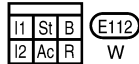
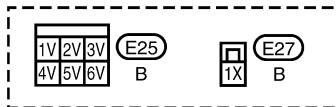
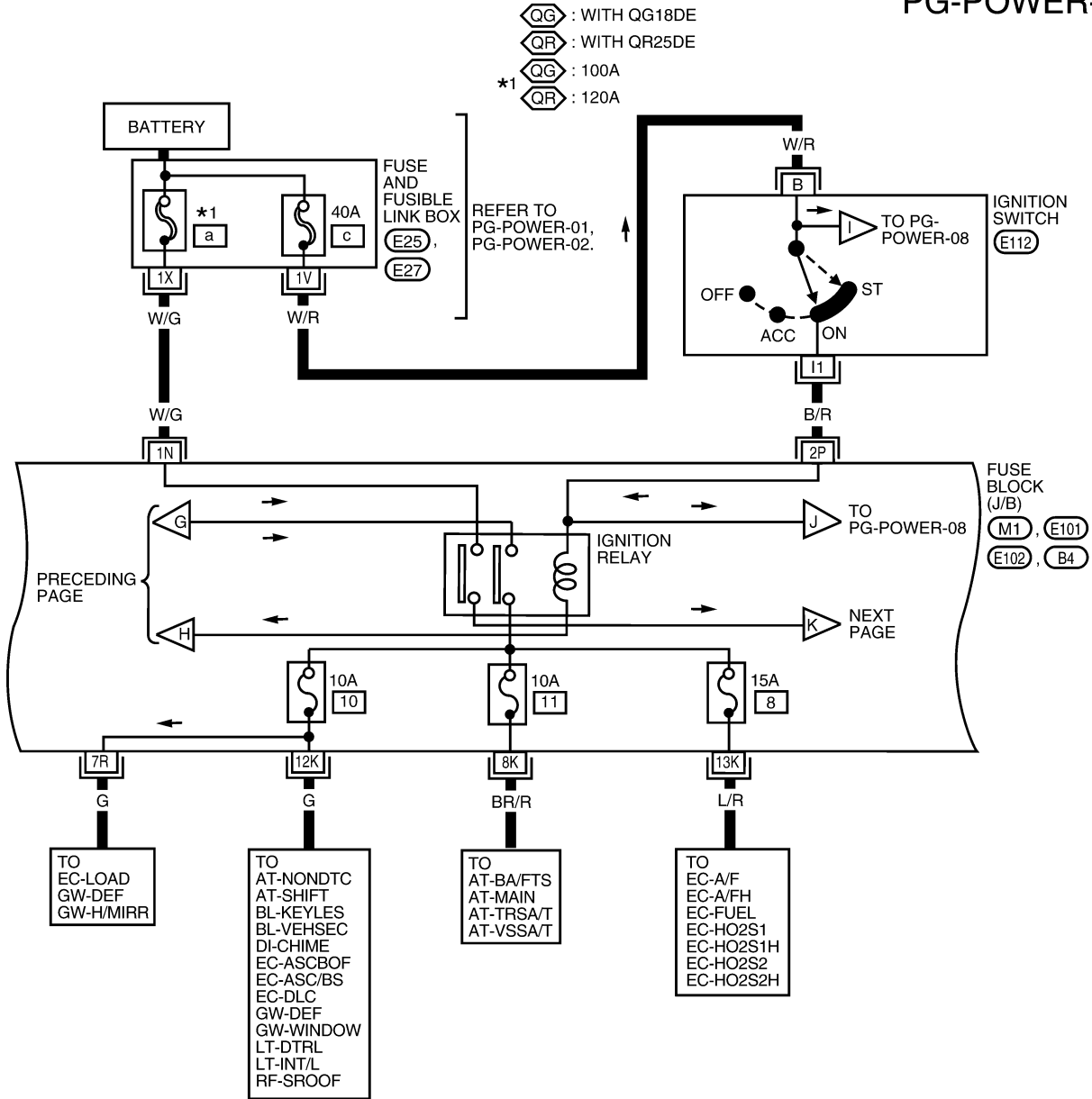

REFER TO THE FOLLOWING.

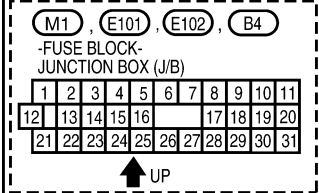

WKWA2093E

POWER SUPPLY ROUTING

PG-POWER-07

 : With ABS

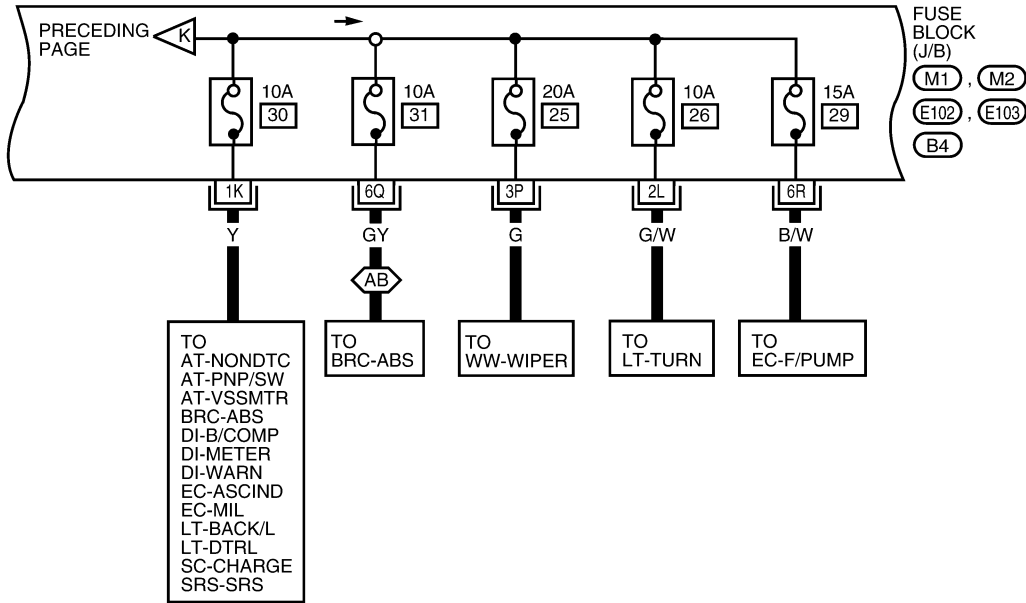

A
B
C
D
E
F
G
H
I
J
PG
L
M

REFER TO THE FOLLOWING.

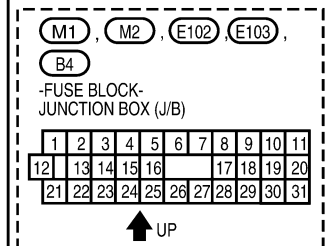

WKWA2094E

POWER SUPPLY ROUTING

PG-POWER-08

QG : WITH QG18DE
QR : WITH QR25DE

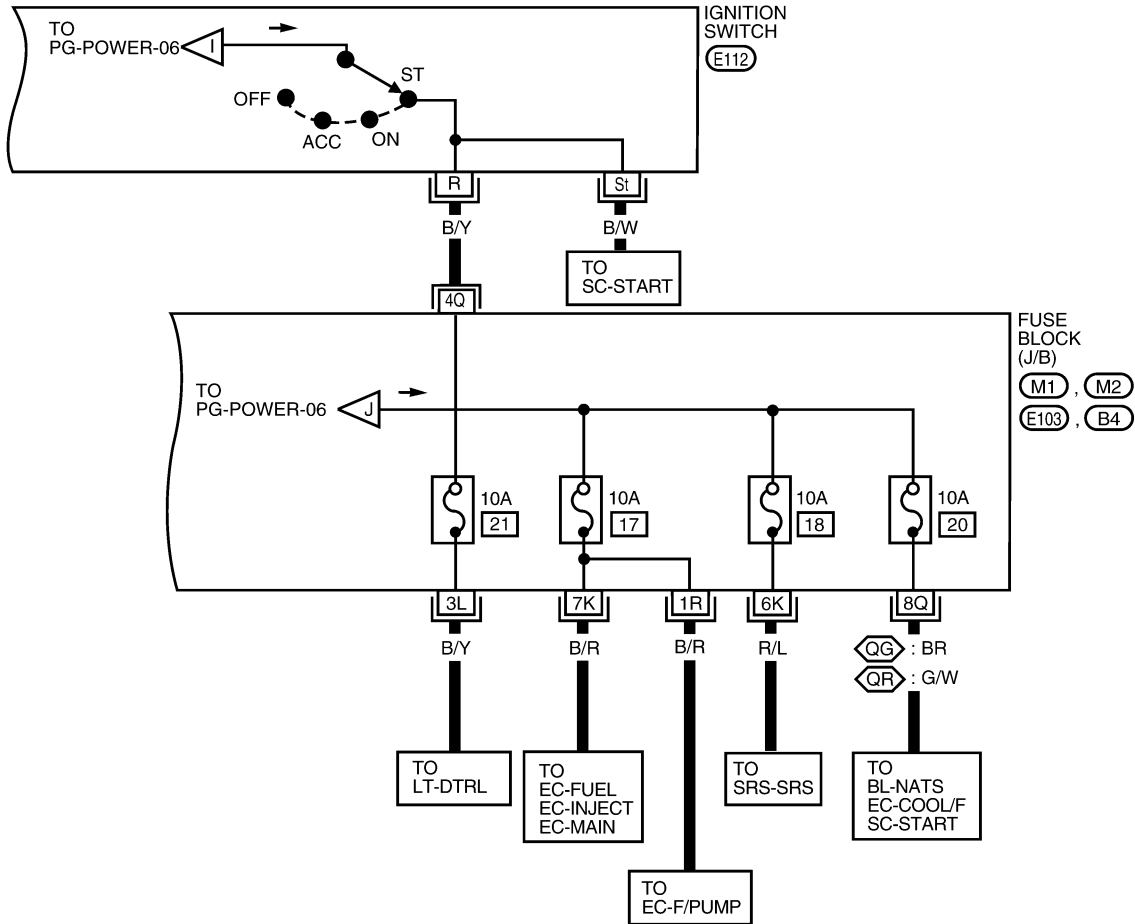

REFER TO THE FOLLOWING.

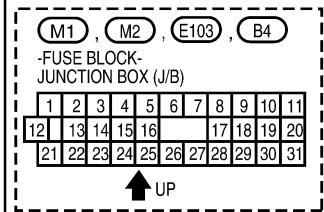

WKWA0496E

GROUND

PF24080

EKS003B1

GROUND Ground Distribution MAIN HARNESS

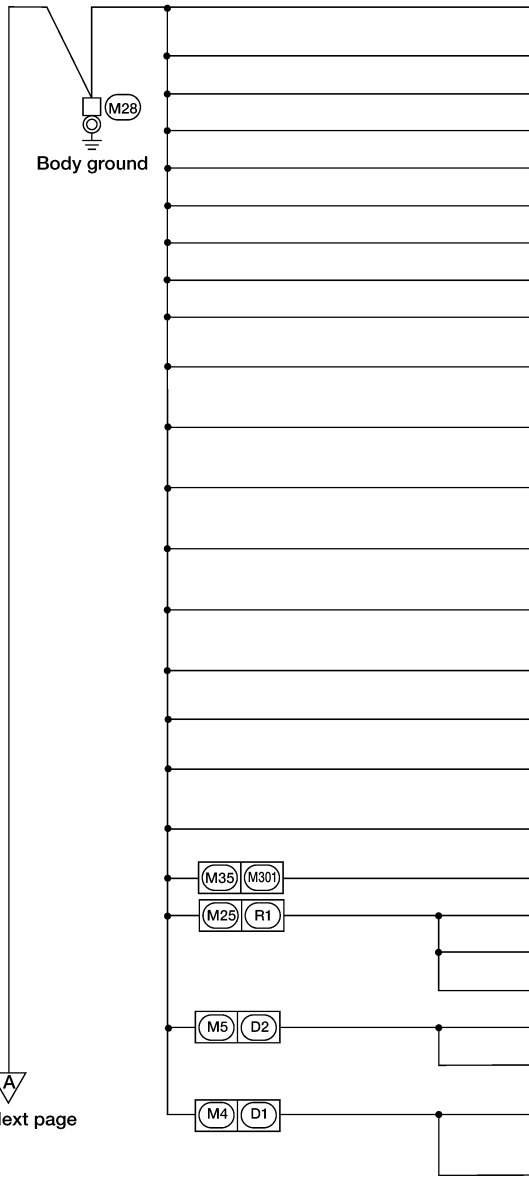
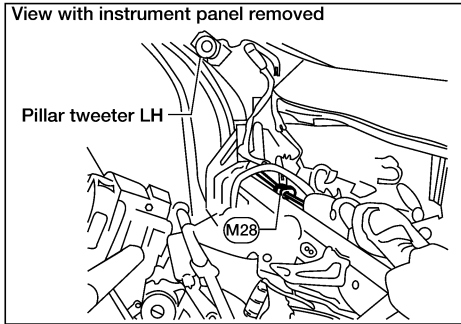

CONNECTOR NUMBER	CONNECT TO
M2	Fuse block (J/B) (Blower motor relay, ignition relay, accessory relay)
M3	Heated mirror relay
M8	Data link connector (Terminal No. 4)
M8	Data link connector (Terminal No. 5)
M9	Power window relay
M10	Trunk lid opener relay
M21	Trunk lid opener switch
M22	Illumination control switch
M23	Door mirror remote control switch
M29	Combination meter (Terminal No.3) (High beam indicator) (With tachometer)
M29	Combination meter (Terminal No.12) (Turn signal indicator lamps) (With tachometer)
M29	Combination meter (Terminal No.14) (High beam indicator) (Without tachometer)
M30	Combination meter (Terminal No. 27) (Without tachometer)
M30	Combination meter (Terminal No. 39) (Turn signal indicator lamps) (Without tachometer)
M30	Combination meter (Terminal No. 48) (QG18DE models with tachometer)
M31	Fan control switch
M38	Smart entrance control unit (With power door locks) (Terminal No. 16)
M40	Time control unit (Without power door locks) (Terminal No. 8)
M302	Power socket
R2	Vanity lamp LH
R3	Map lamp
R7	Vanity lamp RH
D4	Door mirror LH
D8	Front door key cylinder switch LH
D6	Main power window and door lock / unlock switch
D7	Front door lock actuator (door unlock sensor) LH

A
B
C
D
E
F
G
H
I
J
L
M

PG

WKIA0960E

GROUND

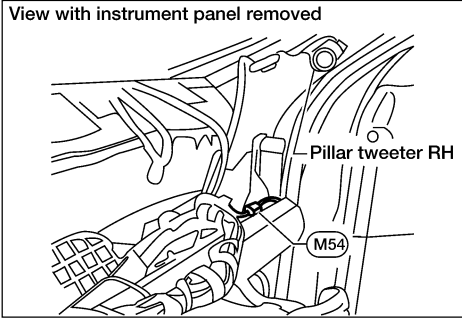

Preceding page

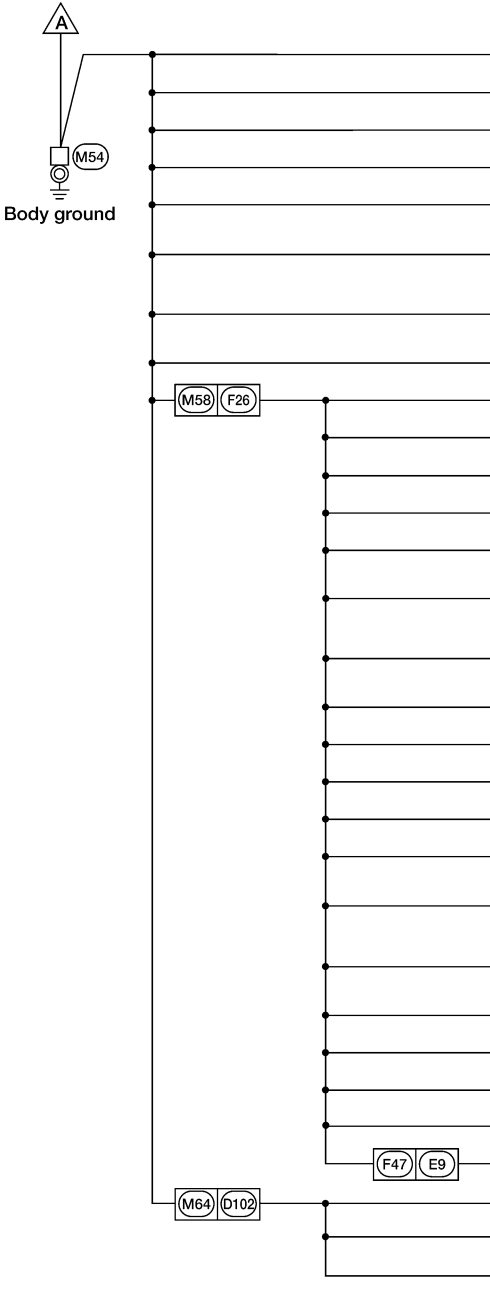

CONNECTOR NUMBER	CONNECT TO
M12	Power socket relay
M32	Air control
M33	Cigarette lighter socket
M34	Air bag diagnosis sensor unit (Terminal No. 2)
M42	Combination flasher unit
M44	A/T device (Terminal No. 2) (Overdrive control switch)
M44	A/T device (Terminal No. 6) (Shift lock)
M49	Intake sensor
F9	Camshaft position sensor (PHASE) (QR25DE)
F11	Crankshaft position sensor (POS) (QR25DE)
F16	Camshaft position sensor (PHASE) (QG18DE)
F18	Knock sensor (Shield wire) (QR25DE)
F31	Knock sensor (Shield wire) (QG18DE)
F50	Electric throttle control actuator (Throttle position sensor) (Shield wire) (QR25DE)
F50	Electric throttle control actuator (Throttle control motor) (Shield wire) (QR25DE)
F52	Crankshaft position sensor (POS) (QG18DE)
F57	TCM (Terminal No. 25) (QG18DE)
F57	TCM (Terminal No. 48) (QG18DE)
F57	TCM (Terminal No. 25) (QR25DE)
F57	TCM (Terminal No. 48) (QR25DE)
F58	Electric throttle control actuator (Throttle control motor) (Shield wire) (QG18DE)
F58	Electric throttle control actuator (Throttle position sensor) (Shield wire) (QG18DE)
F59	ECM (Terminal No. 115)
F59	ECM (Terminal No. 116)
F60	ECM (Terminal No. 1)
F63	Swirl control valve position sensor (Shield wire) (QG18DE SULEV)
E111	Immobilizer control unit (QR25DE)
D104	Door lock / unlock switch RH
D107	Front door lock actuator RH (Door unlock sensor)
D109	Door mirror RH

WKIA3330E

GROUND

ENGINE ROOM HARNESS

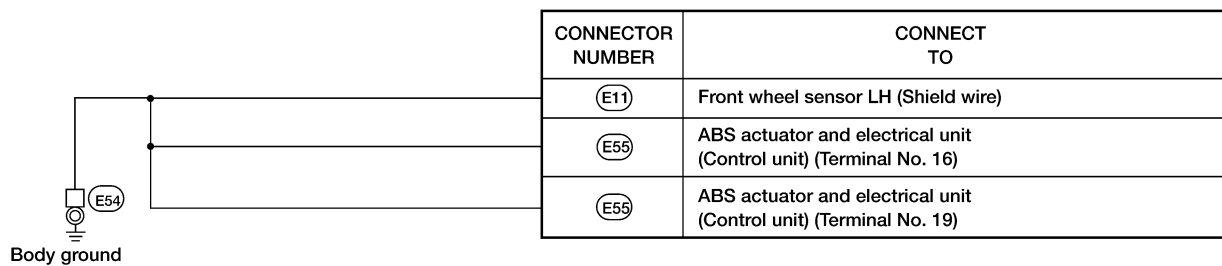
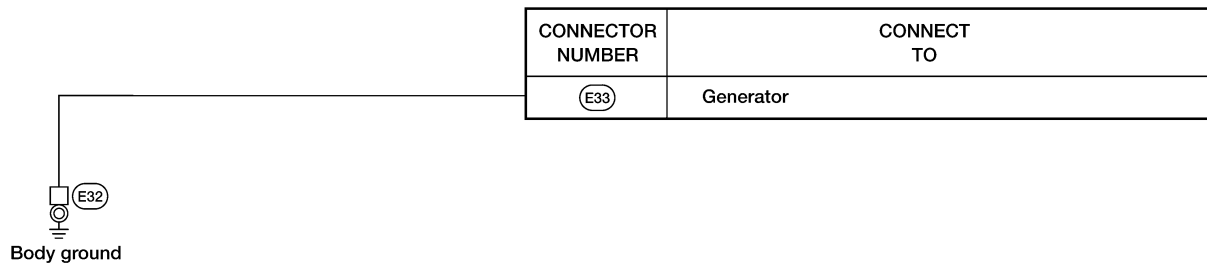
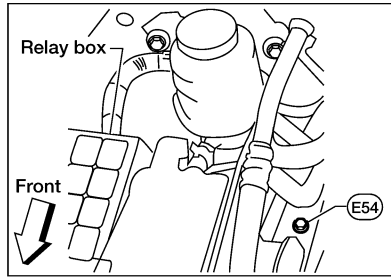
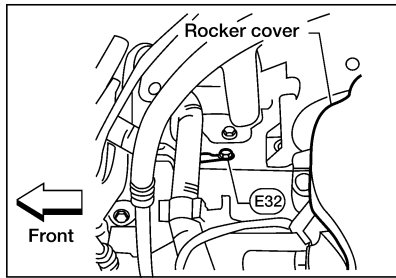

A
B
C
D
E
F
G
H
I
J

PG

L
M

GROUND

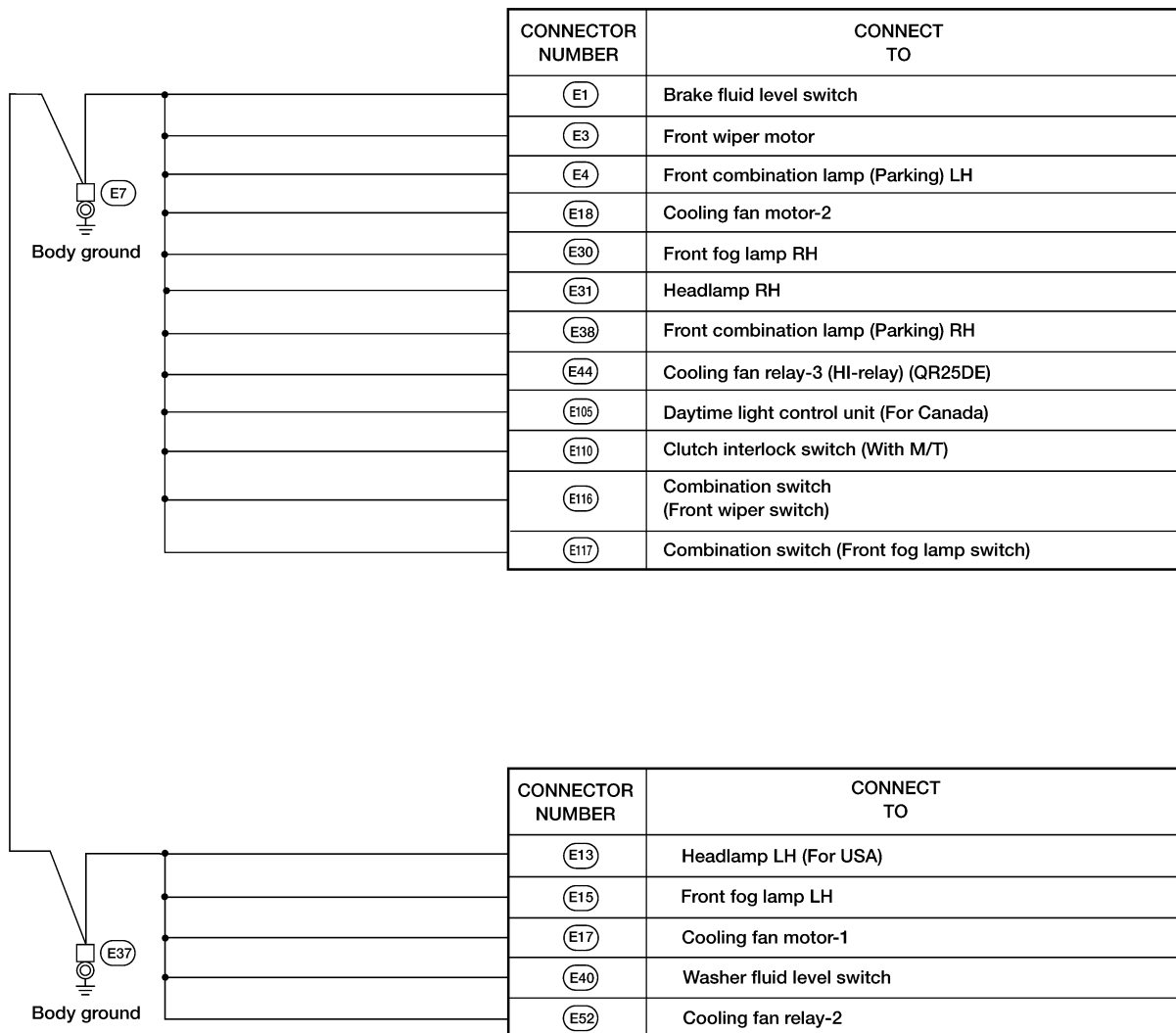
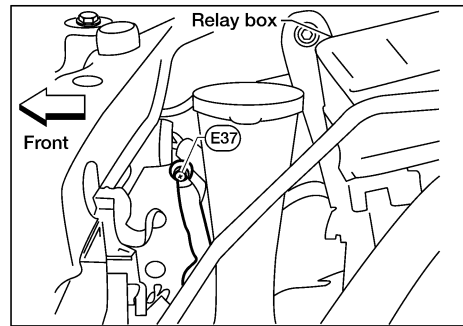
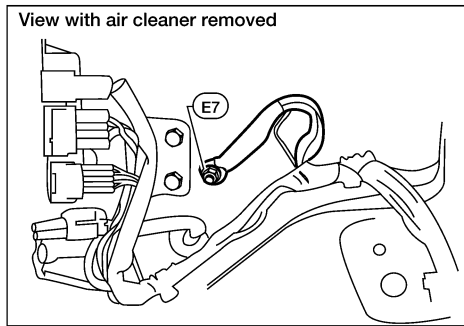

WKIA0962E

GROUND

ENGINE CONTROL HARNESS QG18DE

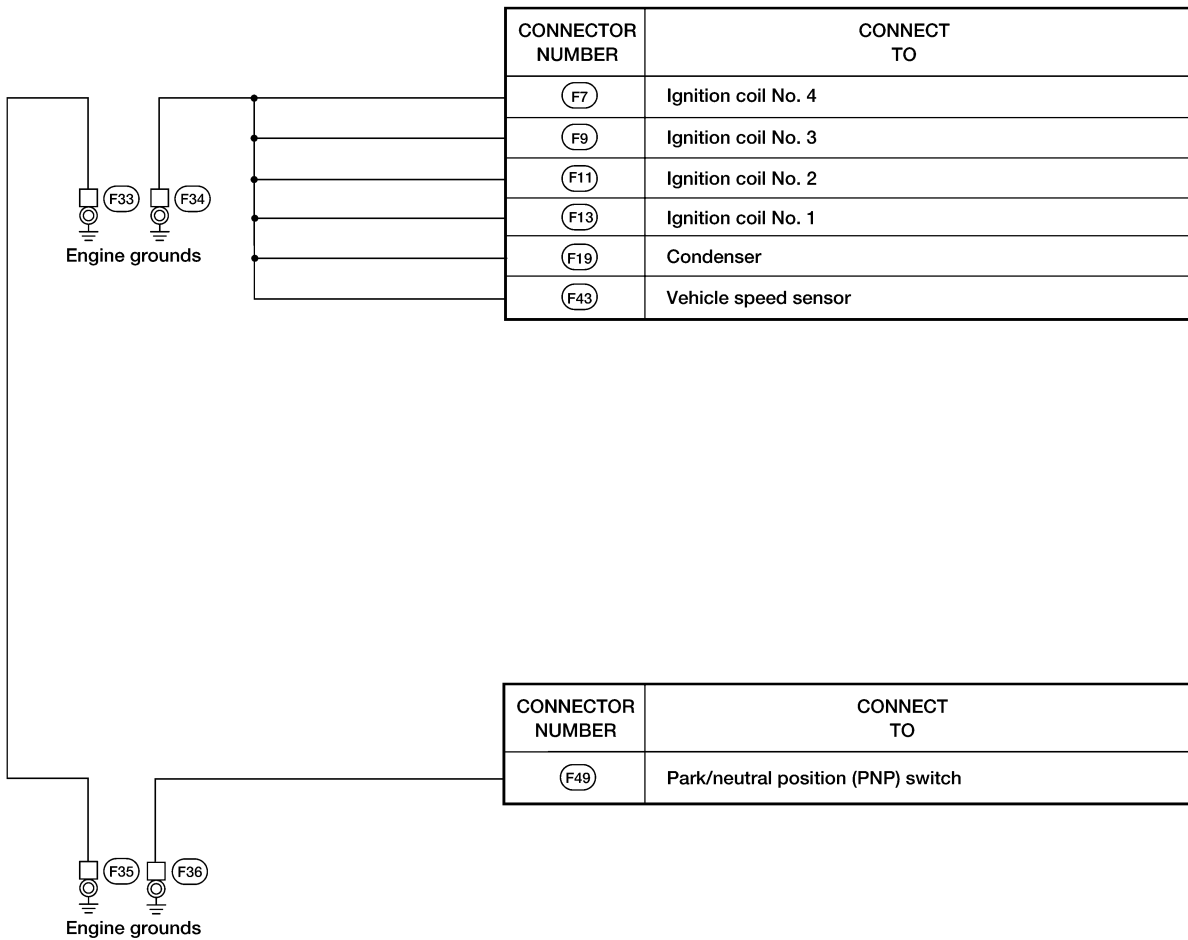
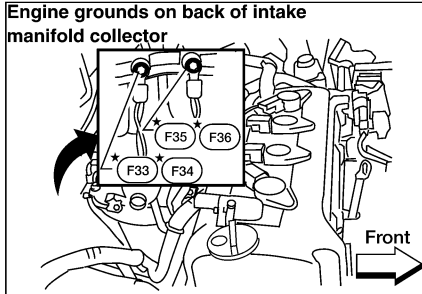

A
B
C
D
E
F
G
H
I
J
PG
L
M

GROUND

QR25DE

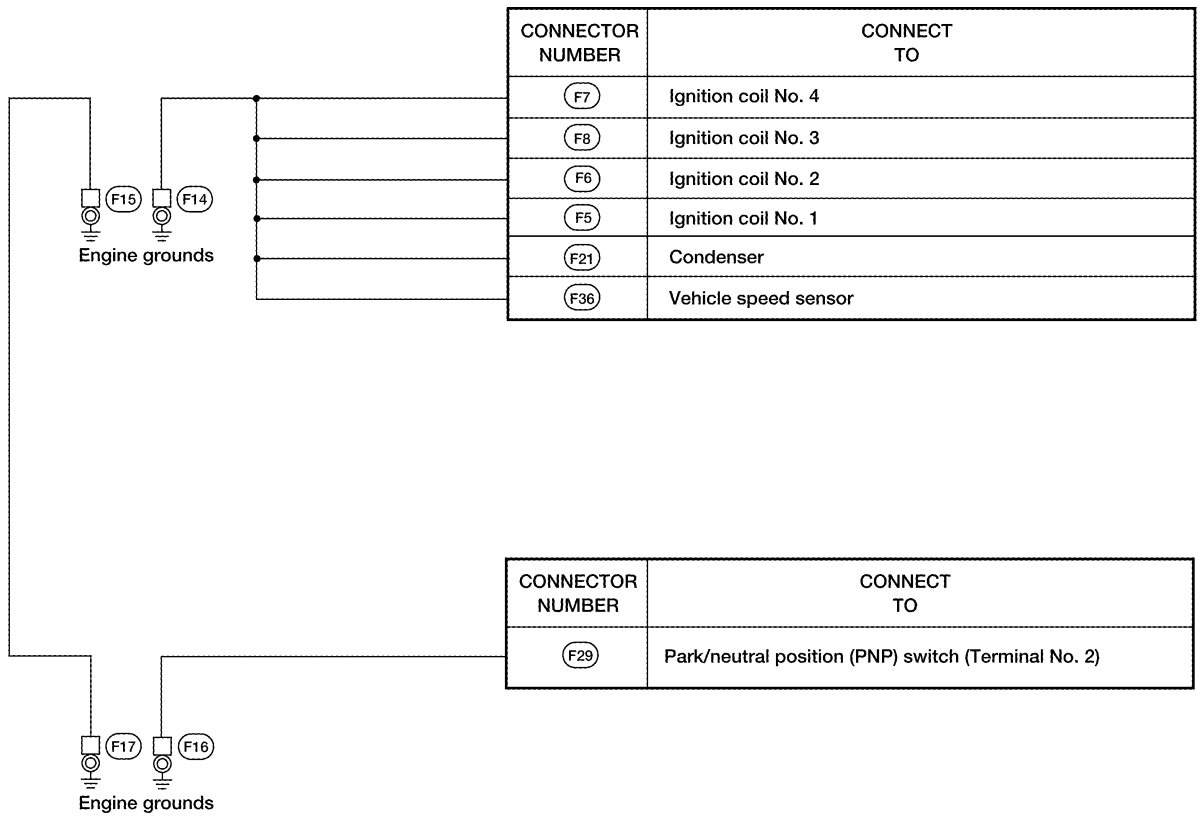
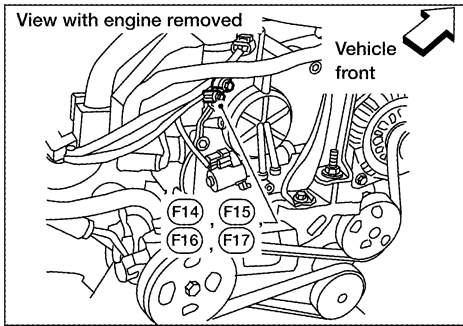

WKIA3331E

GROUND

BODY HARNESS

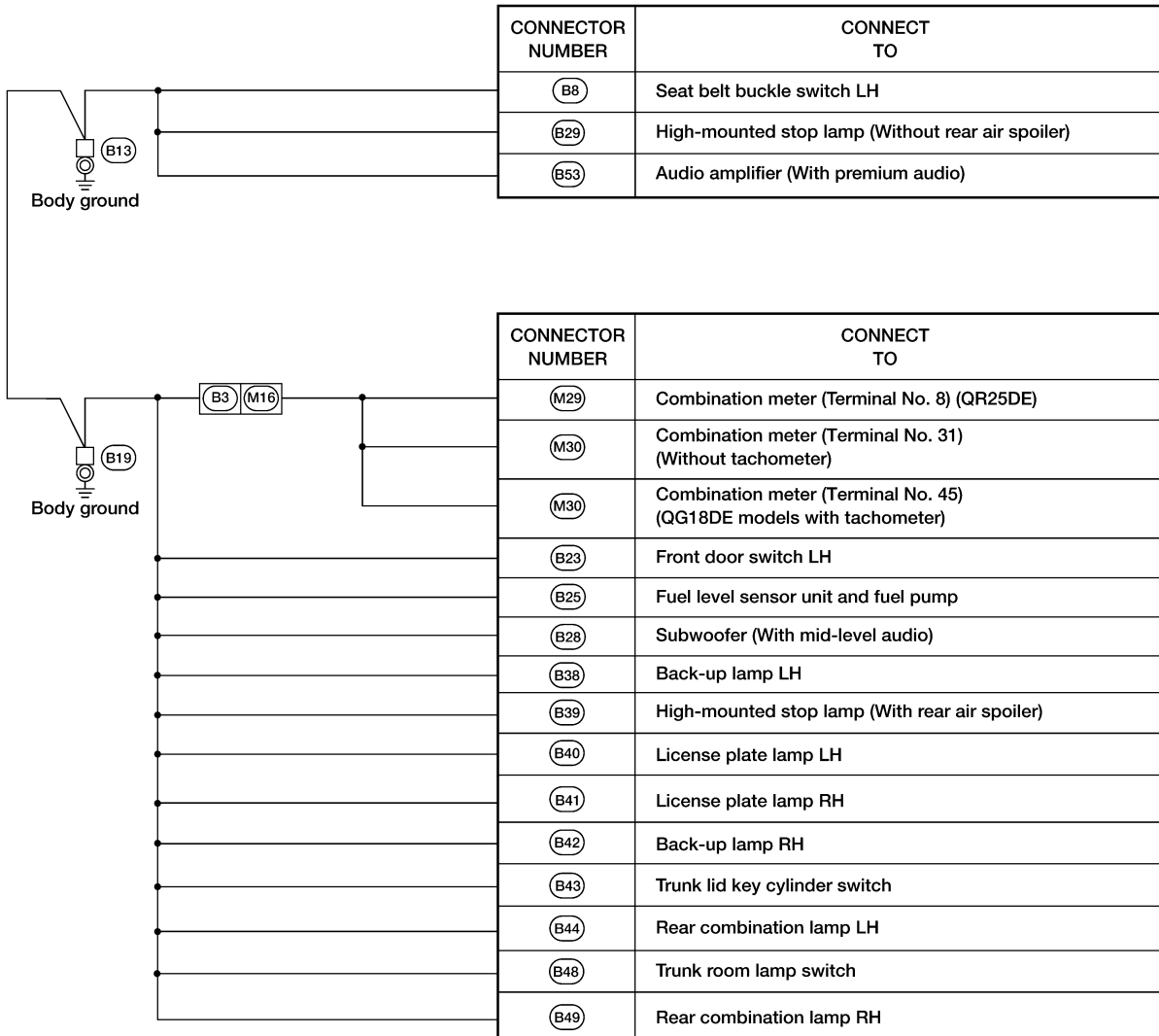
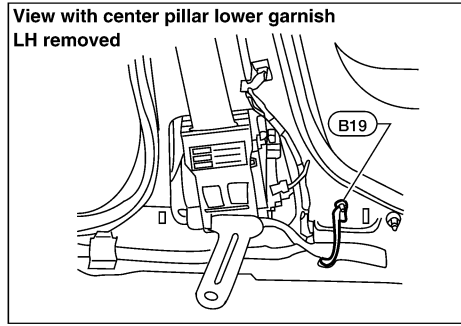
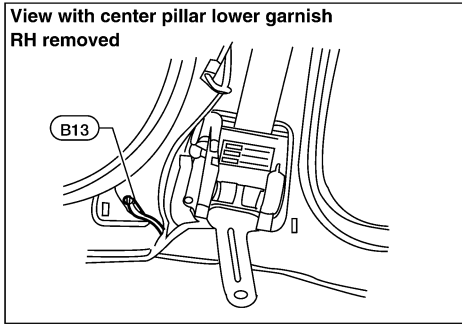

A
B
C
D
E
F
G
H
I
J
L
M

PG

WKIA0964E

GROUND

REAR WINDOW DEFOGGER GROUND HARNESS

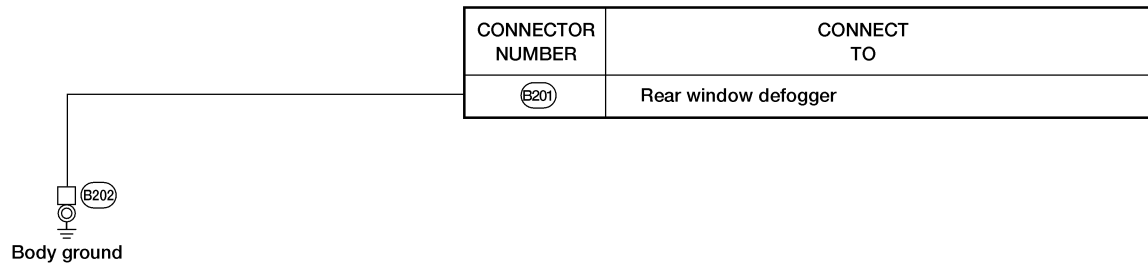
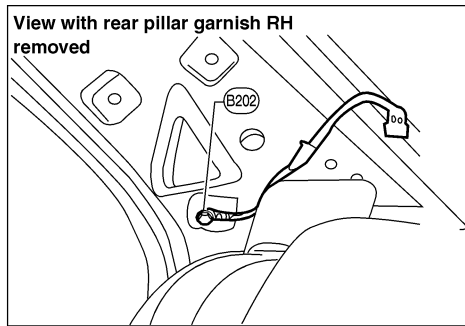

LEL434

GROUND

ROOM HARNESS

A
B
C
D
E
F
G
H
I
J
PG
L
M

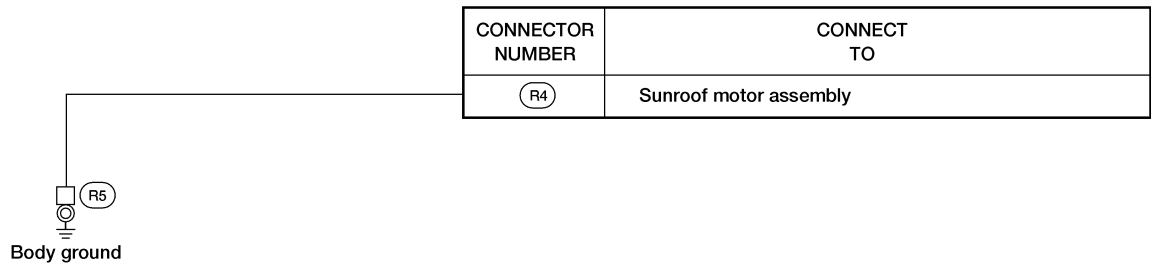
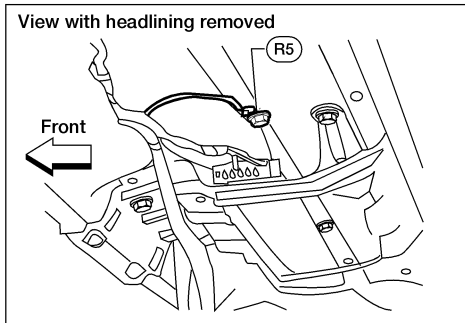

LEL433

HARNESS

Harness Layout

EKS003B2

HOW TO READ HARNESS LAYOUT

The following Harness Layouts use a map style grid to help locate connectors on the drawings:

- Main Harness
- Engine Room Harness
- Engine Control Harness
- Body Harness

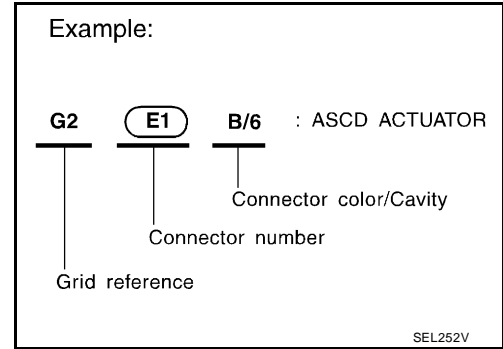













TO USE THE GRID REFERENCE

1. Find the desired connector number on the connector list.
2. Find the grid reference.
3. On the drawing, find the crossing of the grid reference letter column and number row.
4. Find the connector number in the crossing zone.
5. Follow the line (if used) to the connector.

CONNECTOR SYMBOL

Main symbols of connector (in Harness Layout) are indicated in the below.

Connector type	Water proof type		Standard type	
	Male	Female	Male	Female
● Cavity: Less than 4				
● Relay connector				
● Cavity: From 5 to 8				
● Cavity: More than 9				
● Ground terminal etc.	—			

HARNESS

OUTLINE

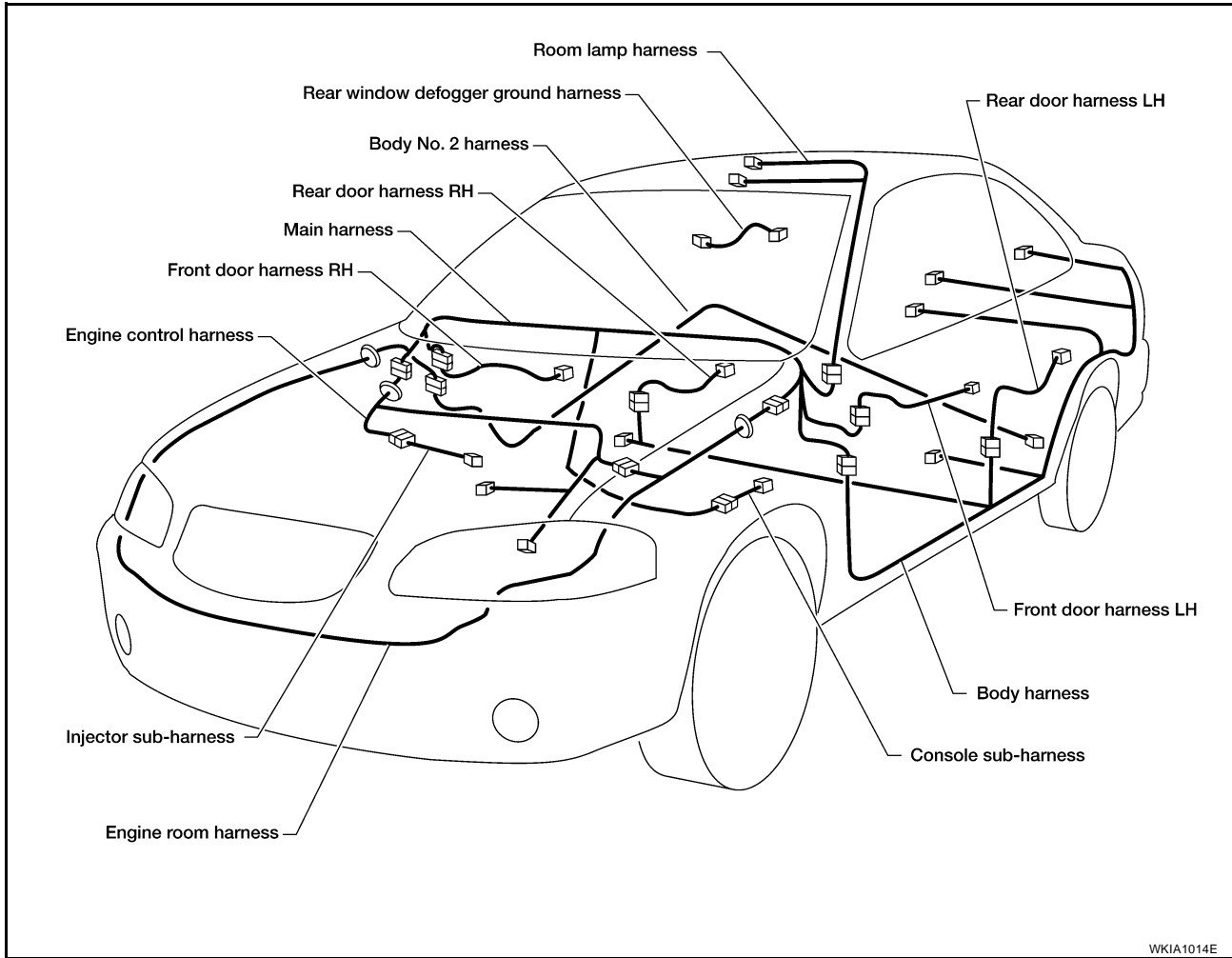

NOTE:

For detailed ground distribution information, refer to [PG-13, "Ground Distribution"](#) .

A
B
C
D
E
F
G
H
I
J

PG

L

M

HARNESS

MAIN HARNESS

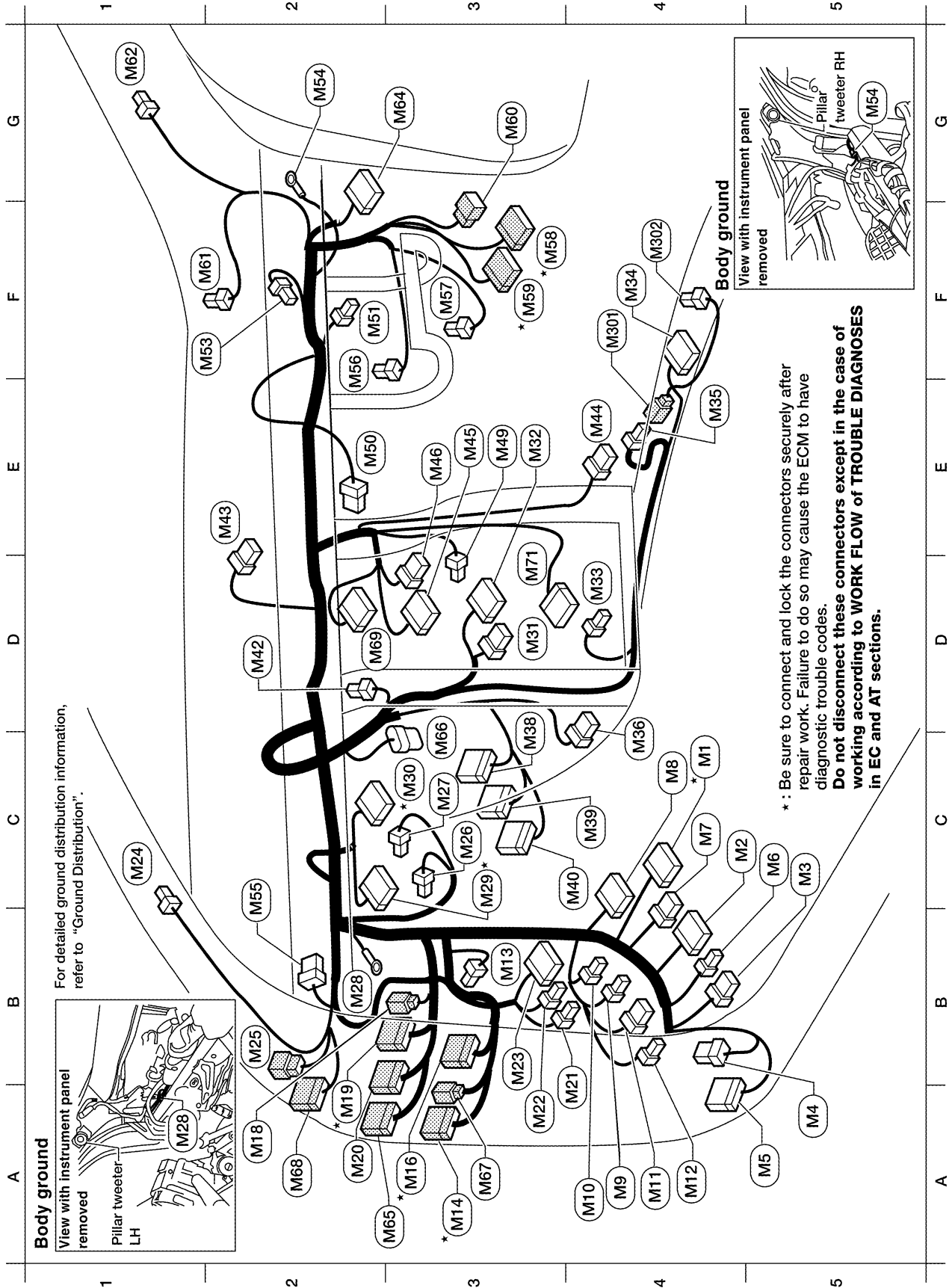

For detailed ground distribution information, refer to "Ground Distribution".

* : Be sure to connect and lock the connectors securely after repair work. Failure to do so may cause the ECM to have diagnostic trouble codes.
Do not disconnect these connectors except in the case of working according to WORK FLOW of TROUBLE DIAGNOSES in EC and AT sections.

Main harness

C4	* (M1) W/16 : Fuse block (J/B)	D3	(M31) W/6 : Fan control switch
C4	(M2) W/12 : Fuse block (J/B)	E3	(M32) W/12 : Air control
C5	(M3) L/4 : Heated mirror relay (for Canada)	D4	(M33) W/3 : Cigarette lighter socket
A5	(M4) W/8 : To (D1)	F4	(M34) Y/20 : Air bag diagnosis sensor unit
A5	(M5) W/16 : To (D2)	E4	(M35) W/2 : To (M30)
C5	(M6) W/2 : Circuit breaker	C4	(M36) Y/7 : Spiral cable
C4	(M7) W/6 : Fuse block (J/B)	C3	(M38) W/18 : Smart entrance control unit (with power door locks)
C4	(M8) W/16 : Data link connector	C4	(M39) B/24 : Smart entrance control unit (with power door locks)
A4	(M9) L/4 : Power window relay	C4	(M40) W/10 : Time control unit (without power door locks)
A4	(M10) L/4 : Trunk lid opener relay	D2	(M42) B/3 : Combination flasher unit
A4	(M11) BR/6 : Remote keyless entry relay	E2	(M43) W/8 : Hazard switch
A4	(M12) L/4 : Power socket relay	E4	(M44) W/8 : A/T device
B3	(M13) L/2 : ASCD clutch switch (M/T with ASCD)	E3	(M45) W/10 : Audio unit
A3	* (M14) BR/16 : To (B1)	E3	(M46) W/6 : Audio unit
A3	* (M16) W/20 : To (B3)	E3	(M48) W/2 : Intake sensor
A2	(M18) W/2 : To (E07)	E2	(M50) B/6 : Intake door motor
A2	* (M19) W/16 : To (E08)	F3	(M51) Y/2 : Front passenger air bag module
A2	(M20) W/10 : To (E09) (QG18DE)	F2	(M53) GY/2 : Diode-2
A2	(M20) W/16 : To (E09) (QR25DE)	G2	(M54) - : Body ground
A4	(M21) B/2 : Trunk lid opener switch	C2	(M55) L/3 : Diode-3
A3	(M22) W/3 : Illumination control switch	F2	(M56) BR/4 : Fan resistor
B3	(M23) W/10 : Door mirror remote control switch	F3	(M57) W/2 : Blower motor
C1	(M24) BR/2 : Door mirror remote control switch	F3	* (M58) W/16 : To (E26)
B2	(M25) W/6 : To (R1)	F3	* (M59) BR/16 : To (F27) (with QG18DE)
C3	(M26) B/2 : Stop lamp switch (With M/T)	F3	* (M59) W/24 : To (F27) (with QR25DE)
C3	(M26) W/4 : Stop lamp switch (With A/T)	G3	(M60) W/6 : To (E28)
C3	(M27) BR/2 : ASCD brake switch	F2	(M61) BR/2 : Security indicator lamp
B2	* (M28) - : Body ground	G1	(M62) BR/2 : Pillar tweeter RH
C3	(M29) W/24 : Combination meter (without tachometer)	G3	(M64) W/16 : To (D10)
C3	* (M29) BR/24 : Combination meter (with tachometer)		
C3	* (M30) BR/20 : Combination meter (without tachometer)		
C3	* (M30) W/24 : Combination meter (with tachometer)		

A2	(M65) W/12 : To (B50)
C3	(M66) B/6 : Accelerator pedal position sensor
A3	(M67) W/2 : To (B51)
A2	(M68) W/24 : To (B55)
D2	(M69) W/12 : Audio unit
D3	(M71) W/16 : CD autochanger

Console Sub-harness

F4	(M80) W/2 : To (M35)
F4	(M82) B/3 : Power socket

(M53) : Diode-2

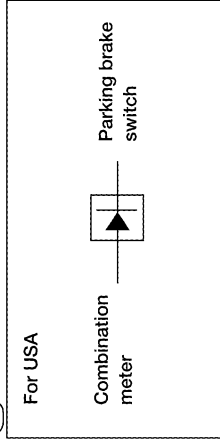

(M55) : Diode-3 (QG18DE Canada models and all QR25DE)

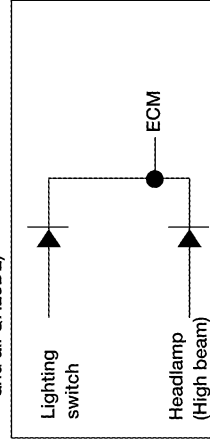

* : Be sure to connect and lock the connectors securely after repair work. Failure to do so may cause the ECM to have diagnostic trouble codes.

Do not disconnect these connectors except in the case of working according to WORK FLOW of TROUBLE DIAGNOSES in EC and AT sections.

WKIA3333E

HARNESS

ENGINE ROOM HARNESS

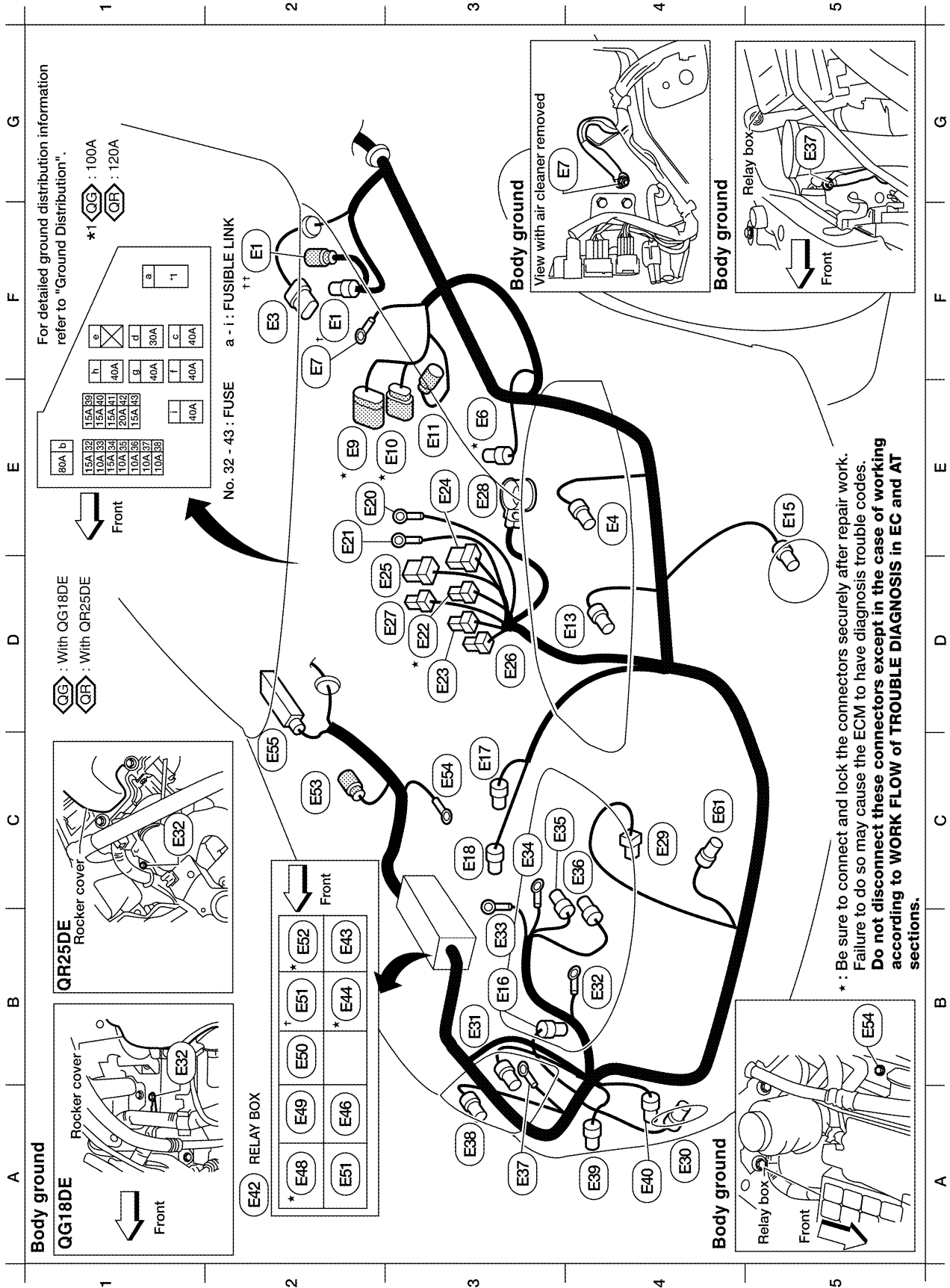

WKIA3334E

F2	[†] (E1) GY/2	: Brake fluid level switch (with QG18DE)
F2	^{††} (E1) GY/2	: Brake fluid level switch (with QR25DE)
F2	(E3) GY/6	: Front wiper motor
E4	(E4) B/3	: Front combination lamp LH
E3	(E6) GY/2	: Dropping resistor
F2	(E7) -	: Body ground
E2	(E9) GY/9	: To (F47)
E3	(E10) G/8	: To (F48)
E3	(E11) BR/2	: Front wheel sensor LH
D4	(E13) G/3	: Headlamp LH
E5	(E19) B/2	: Front fog lamp LH
B3	(E16) B/3	: Refrigerant pressure sensor
C3	(E17) GY/4	: Cooling fan motor 1
C3	(E18) GY/2	: Cooling fan motor 2 (with QG18DE)
C3	(E18) GY/4	: Cooling fan motor 2 (with QR25DE)
E2	(E20) -	: Fuse and fusible link box
E2	(E21) -	: Fuse and fusible link box
D3	(E22) W/3	: Fuse and fusible link box
D3	(E23) W/4	: Fuse and fusible link box
E3	(E24) W/6	: Fuse and fusible link box
D3	(E25) B/6	: Fuse and fusible link box
D3	(E26) W/1	: Fuse and fusible link box
D3	(E27) B/1	: Fuse and fusible link box
E3	(E28) -	: Battery (positive)
C4	(E29) B/1	: Horn
A4	(E30) B/2	: Front fog lamp RH

B3	(E31) G/3	: Headlamp RH
B4	(E32) -	: Body ground
B3	(E33) -	: Generator
C3	(E34) -	: Generator
C3	(E35) GY/2	: Generator
C4	(E36) B/1	: A/C compressor
A3	(E37) -	: Body ground
A3	(E38) B/3	: Front combination lamp RH
A4	(E39) GY/2	: Front washer motor
A4	(E40) BR/2	: Washer fluid level switch
A2	(E42) -	: Relay box
B2	(E43) BR/6	: Vehicle security lamp relay
B2	* (E44) BR/6	: Cooling fan relay-3 (with QR25DE)
A2	(E46) L/4	: Front fog lamp relay
A2	* (E48) BR/6	: Cooling fan relay-1
A2	(E49) W/3	: Horn relay
B2	(E50) L/4	: A/C relay
A2	(E51) L/4	: Clutch interlock relay (M/T)
B2	[†] (E51) L/4	: Park/neutral position (PNP) relay (A/T)
B2	* (E52) BR/6	: Cooling fan relay-2
C2	(E53) GY/2	: Front wheel sensor RH
C3	(E54) -	: Body ground
C2	(E55) B/31	: ABS actuator and electric unit (control unit)
C4	(E61) B/2	: Ambient air temperature sensor

* : Be sure to connect and lock the connectors securely after repair work. Failure to do so may cause the ECM to have diagnostic trouble codes.

Do not disconnect these connectors except in the case of working according to WORK FLOW of TROUBLE DIAGNOSES in EC and AT sections.

HARNESS

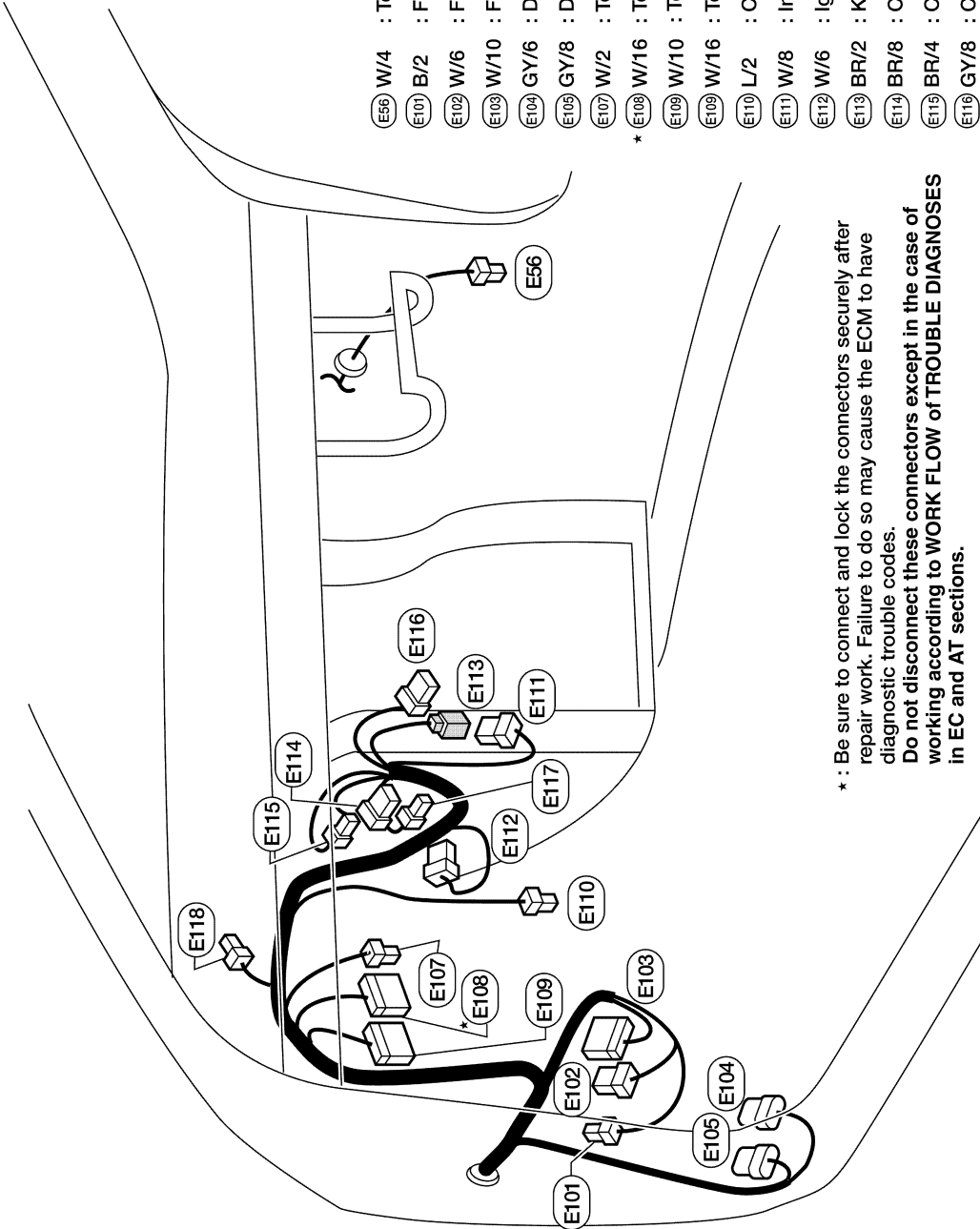

- Ⓔ E56 W/4 : To Ⓔ E100
- Ⓔ E101 B/2 : Fuse block (J/B)
- Ⓔ E102 W/6 : Fuse block (J/B)
- Ⓔ E103 W/10 : Fuse block (J/B)
- Ⓔ E104 GY/6 : Daytime light control unit
- Ⓔ E105 GY/8 : Daytime light control unit
- Ⓔ E107 W/2 : To Ⓔ M18
- Ⓔ E108 W/16 : To Ⓔ M19
- * Ⓔ E109 W/10 : To Ⓔ M20 (QG18DE)
- Ⓔ E109 W/16 : To Ⓔ W20 (QR25DE)
- Ⓔ E110 L/2 : Clutch interlock switch (M/T)
- Ⓔ E111 W/8 : Immobilizer control unit
- Ⓔ E112 W/6 : Ignition switch
- Ⓔ E113 BR/2 : Key switch
- Ⓔ E114 BR/8 : Combination switch (Lighting switch)
- Ⓔ E115 BR/4 : Combination switch (Lighting switch)
- Ⓔ E116 GY/8 : Combination switch (Front wiper switch)
- Ⓔ E117 W/3 : Combination switch (Front fog lamp switch)
- Ⓔ E118 W/2 : Diode-5

* : Be sure to connect and lock the connectors securely after repair work. Failure to do so may cause the ECM to have diagnostic trouble codes.
 Do not disconnect these connectors except in the case of working according to WORK FLOW of TROUBLE DIAGNOSES in EC and AT sections.

Ⓔ E118 : Diode-5

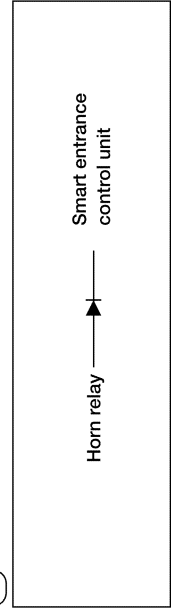

HARNESS

ENGINE CONTROL HARNESS QG18DE (ULEV)

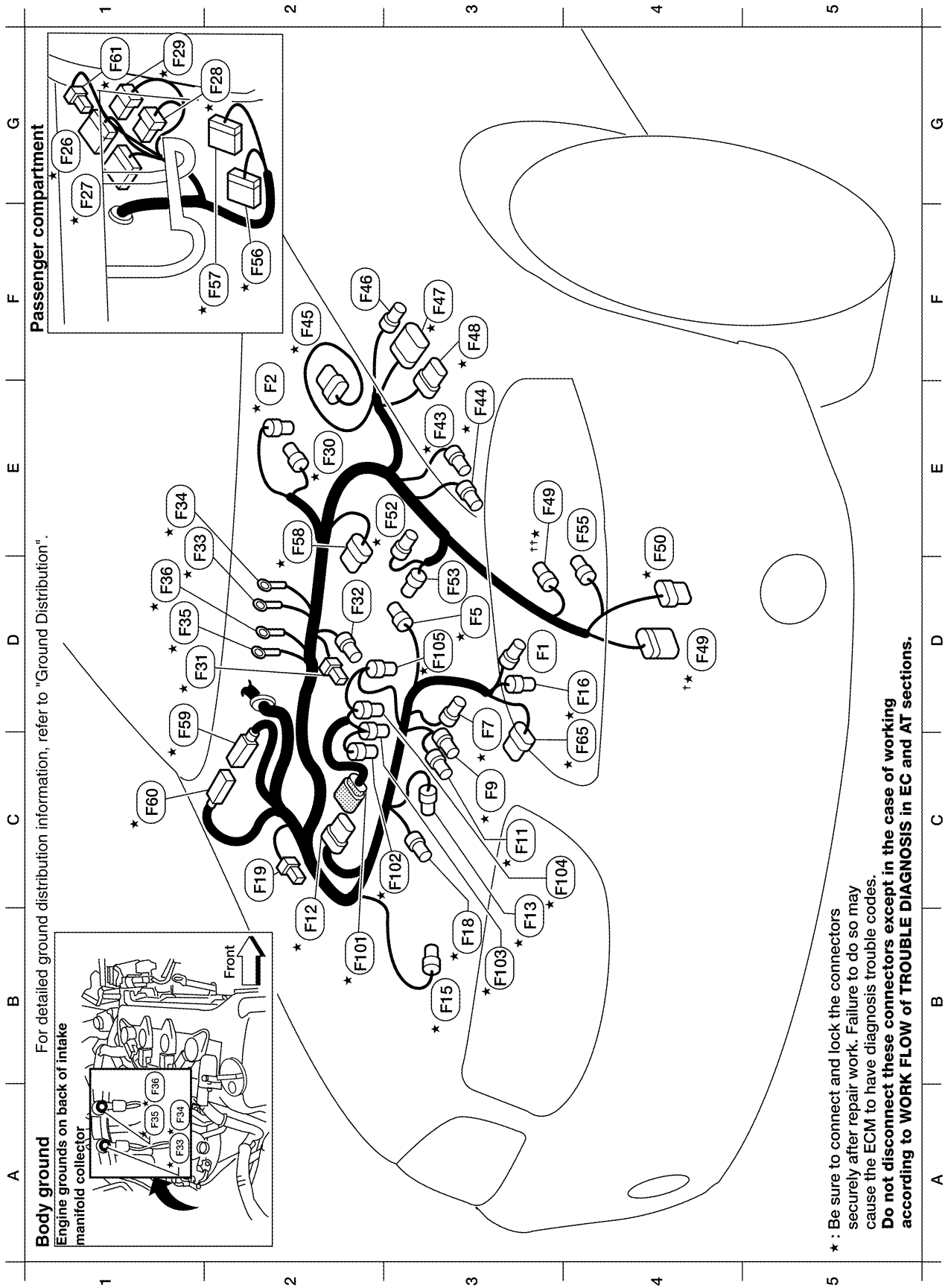

Body ground For detailed ground distribution information, refer to "Ground Distribution".

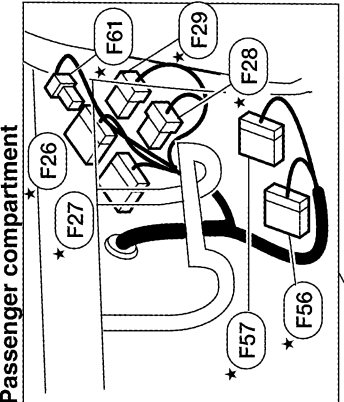
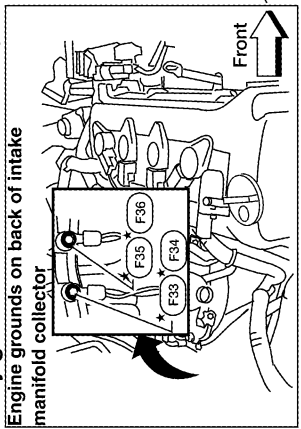

* : Be sure to connect and lock the connectors securely after repair work. Failure to do so may cause the ECM to have diagnosis trouble codes.
Do not disconnect these connectors except in the case of working according to WORK FLOW of TROUBLE DIAGNOSIS in EC and AT sections.

WKIA3336E

Engine control harness

D3	* (F1) G/4	: Heated oxygen sensor 1	F2	* (F46) B/6	: Mass air flow sensor
E2	* (F2) G/4	: Heated oxygen sensor 2	F2	(F46) GY/1	: To (EB)
D3	* (F5) L/2	: EVAP canister purge volume control solenoid valve	F3	* (F47) GY/9	: To (EB)
D3	* (F7) GY/3	: Ignition coil No. 4	F3	* (F48) GY/8	: To (E10)
C3	* (F9) GY/3	: Ignition coil No. 3	E3	** (F49) B/2	: Park/neutral position (PNP) switch (M/T)
C3	* (F11) GY/3	: Ignition coil No. 2	D4	* (F49) B/10	: Park/neutral position (PNP) switch (A/T)
B2	* (F12) GY/6	: To (F10)	D4	* (F50) B/8	: Terminal cord assembly (A/T)
B3	* (F13) GY/3	: Ignition coil No. 1	E3	* (F52) B/3	: Crankshaft position sensor (POS)
B3	* (F15) GY/2	: Engine coolant temperature sensor	D3	(F53) GY/1	: Starter motor
D4	* (F16) B/3	: Camshaft position sensor (PHASE)	E4	(F55) B/2	: Back-up lamp switch (M/T)
B3	* (F18) GY/2	: Intake valve timing control solenoid valve	F2	* (F56) W/24	: TCM (Transmission control module) (A/T)
C2	(F19) W/2	: Condenser	F2	* (F57) GY/24	: TCM (Transmission control module) (A/T)
G1	* (F26) W/16	: To (M58)	E2	* (F58) G/6	: Electric throttle control actuator
F1	* (F27) BR/16	: To (M59)	D1	* (F59) SMJ	: ECM
G2	* (F28) W/6	: To (M60)	C1	* (F60) SMJ	: ECM
G1	* (F29) BR/6	: ECM Relay	G1	* (F61) L/4	: Throttle control motor relay
E2	* (F30) B/3	: Power steering pressure sensor	C4	* (F65) B/6	: Air fuel ratio (A/F) sensor 1
D1	* (F31) B/2	: Knock sensor			
D2	(F32) GY/1	: Oil pressure switch			
E1	* (F33) -	: Engine ground			
E1	* (F34) -	: Engine ground			
D1	* (F35) -	: Engine ground			
D1	* (F36) -	: Engine ground			
E3	* (F43) GY/2	: Vehicle speed sensor			
E3	* (F44) BR/3	: Revolution sensor (A/T)			

Engine control sub-harness	
B2	* (F101) GY/6 : To (F12)
C3	* (F102) GY/2 : Fuel injector No. 1
B3	* (F103) GY/2 : Fuel injector No. 2
C4	* (F104) GY/2 : Fuel injector No. 3
D3	* (F105) GY/2 : Fuel injector No. 4

* : Be sure to connect and lock the connectors securely after repair work. Failure to do so may cause the ECM to have diagnostic trouble codes.
Do not disconnect these connectors except in the case of working according to WORK FLOW of TROUBLE DIAGNOSES in EC and AT sections.

WKIA4288E

HARNESS

QG18DE (SULEV)

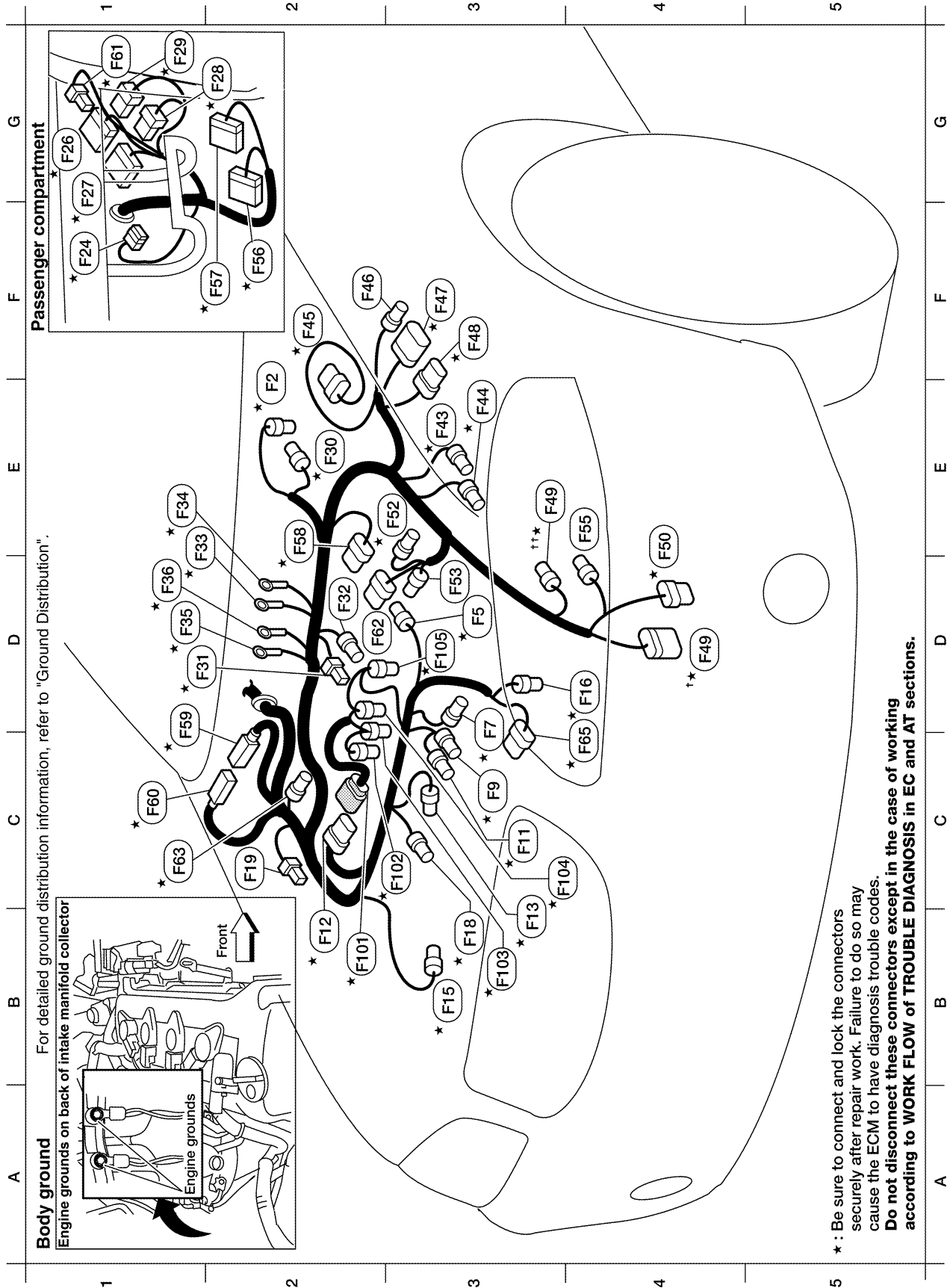

★ : Be sure to connect and lock the connectors securely after repair work. Failure to do so may cause the ECM to have diagnosis trouble codes. Do not disconnect these connectors except in the case of working according to **WORK FLOW of TROUBLE DIAGNOSIS** in EC and AT sections.

WKIA0971E

A B C D E F G H I J K L M N O P Q R S T U V W X Y Z

PG

E2	* (F2) G/4	: Heated oxygen sensor 2	F2	* (F46) B/6	: Mass air flow sensor
D3	* (F5) L/2	: EVAP canister purge volume control solenoid valve	F2	(F46) GY/1	: To (E8)
D3	* (F7) GY/3	: Ignition coil No. 4	F3	* (F47) GY/9	: To (E9)
C3	* (F9) GY/3	: Ignition coil No. 3	F3	* (F48) GY/8	: To (E10)
C3	* (F11) GY/3	: Ignition coil No. 2	E3	** (F49) B/2	: Park/neutral position (PNP) switch (M/T)
B2	* (F12) GY/6	: To (F10)	D4	* (F49) B/10	: Park/neutral position (PNP) switch (A/T)
B3	* (F13) GY/3	: Ignition coil No. 1	D4	* (F50) B/8	: Terminal cord assembly (A/T)
B3	* (F15) GY/2	: Engine coolant temperature sensor	E3	* (F52) B/3	: Crankshaft position sensor (POS)
D4	* (F16) B/3	: Camshaft position sensor (PHASE)	D3	(F53) GY/1	: Starter motor
B3	* (F18) G/2	: Intake valve timing control solenoid valve	E4	(F55) B/2	: Back-up lamp switch (M/T)
C2	(F19) W/2	: Condenser	F2	* (F56) W/24	: TCM (Transmission control module) (A/T)
G1	* (F26) W/16	: To (M58)	F2	* (F57) GY/24	: TCM (Transmission control module) (A/T)
F1	* (F27) BR/16	: To (M59)	E2	(F58) G/6	: Electric throttle control actuator
G2	* (F28) W/6	: To (M60)	D1	* (F59) SMJ	: ECM
G1	* (F29) BR/6	: ECM Relay	C1	* (F60) SMJ	: ECM
E2	* (F30) B/3	: Power steering pressure sensor	G1	* (F61) L/4	: Throttle control motor relay
D1	* (F31) B/2	: Knock sensor	D2	* (F62) GY/6	: Swirl control valve
D2	(F32) GY/1	: Oil pressure switch	C1	* (F63) BR/3	: Swirl control valve position sensor
E1	* (F33) -	: Engine ground	D4	* (F65) B/6	: Air fuel ratio (A/F) sensor 1
E1	* (F34) -	: Engine ground	Engine control sub-harness		
D1	* (F35) -	: Engine ground	B2	* (F101) GY/6	: To (F12)
D1	* (F36) -	: Engine ground	C2	* (F102) GY/2	: Fuel injector No. 1
E3	* (F43) GY/2	: Vehicle speed sensor	B3	* (F103) GY/2	: Fuel injector No. 2
E3	* (F44) BR/3	: Revolution sensor (A/T)	C4	* (F104) GY/2	: Fuel injector No. 3
			D3	* (F105) GY/2	: Fuel injector No. 4

* : Be sure to connect and lock the connectors securely after repair work. Failure to do so may cause the ECM to have diagnostic trouble codes.
Do not disconnect these connectors except in the case of working according to WORK FLOW of TROUBLE DIAGNOSES in EC and AT sections.

WKIA4289E

HARNESS

QR25DE

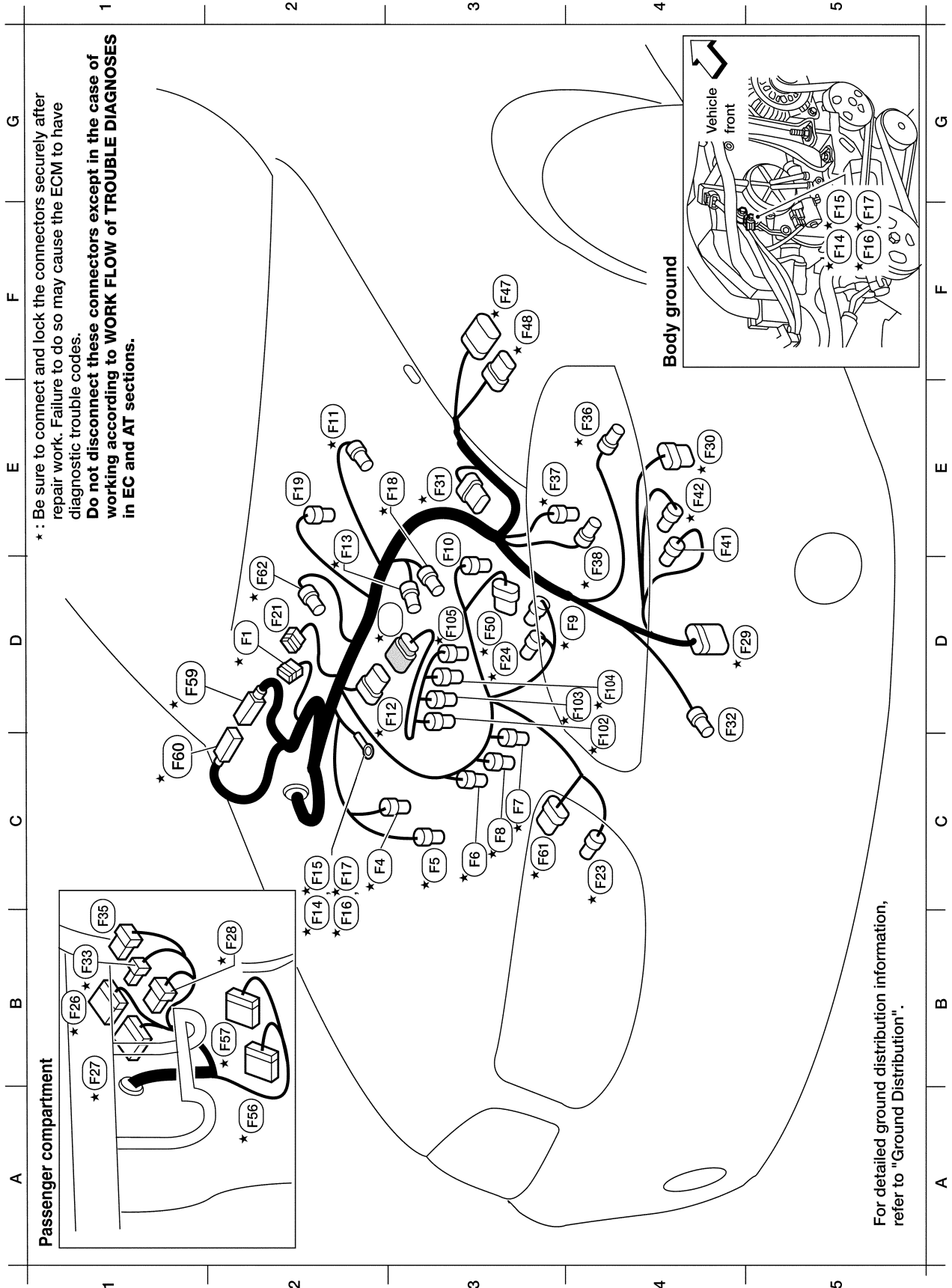

* : Be sure to connect and lock the connectors securely after repair work. Failure to do so may cause the ECM to have diagnostic trouble codes.
Do not disconnect these connectors except in the case of working according to WORK FLOW of TROUBLE DIAGNOSES in EC and AT sections.

Passenger compartment

Body ground

For detailed ground distribution information, refer to "Ground Distribution".

WKIA4602E

HARNESS

D2	*	(F1)	BR/20	: Joint connector -1	E3	*	(F31)	B/6	: Mass air flow sensor
C2	*	(F4)	G/2	: Intake valve timing control solenoid valve	D4	(F32)	GY/1	: Starter motor	
C3	*	(F5)	GY/3	: Ignition coil No. 1	B1	*	(F33)	L/4	: Throttle control motor relay
C3	*	(F6)	GY/3	: Ignition coil No. 2	B1	*	(F35)	BR/6	: ECM relay
C3	*	(F7)	GY/3	: Ignition coil No. 4	E4	*	(F36)	GY/2	: Vehicle speed sensor
C3	*	(F8)	GY/3	: Ignition coil No. 3	E4	*	(F37)	B/3	: Turbine revolution sensor (with A/T)
D4	*	(F9)	B/3	: Camshaft position sensor (PHASE)	D4	*	(F38)	B/3	: Revolution sensor (with A/T)
E3	*	(F10)	L/2	: EVAP canister purge volume control solenoid valve	E4	(F41)	B/2	: Back-up lamp switch (with M/T)	
E2	*	(F11)	B/3	: Crankshaft position sensor	E4	*	(F42)	B/2	: Park/neutral position (PNP) switch (with M/T)
D3	*	(F12)	GY/6	: To (E10)	F3	*	(F47)	GY/9	: To (E9)
E2	*	(F13)	BR/2	: VIAS control solenoid valve	F3	*	(F48)	GY/8	: To (E10)
B2	*	(F14)	-	: Engine ground	D3	*	(F50)	G/6	: Electric throttle control actuator
C2	*	(F15)	-	: Engine ground	A2	*	(F56)	W/24	: TCM (transmission control module) (with A/T)
B2	*	(F16)	-	: Engine ground	B2	*	(F57)	GY/24	: TCM (transmission control module) (with A/T)
C2	*	(F17)	-	: Engine ground	D2	*	(F59)	SMJ	: ECM
E3	*	(F18)	B/2	: Knock sensor	C2	*	(F60)	SMJ	: ECM
E2	*	(F19)	GY/1	: Oil pressure switch	C3	*	(F61)	B/6	: Air fuel ratio (A/F) sensor 1
D2	(F21)	W/2	: Condenser	D2	*	(F62)	B/3	: Power steering pressure sensor	
C4	*	(F23)	G/4	: Heated oxygen sensor 2					
D3	*	(F24)	GY/2	: Engine coolant temperature sensor					
B1	*	(F26)	W/16	: To (M58)					
B1	*	(F27)	W/24	: To (M59)					
B2	*	(F28)	W/6	: To (M60)					
D4	*	(F29)	B/10	: Park/neutral position (PNP) switch (with A/T)					
E4	*	(F30)	B/8	: Terminal cord assembly (with A/T)					

Engine Control Sub-harness

D3	*	(F101)	B/6	: To (F12)
D4	*	(F102)	GY/2	: Fuel injector No. 1
D4	*	(F103)	GY/2	: Fuel injector No. 2
D4	*	(F104)	GY/2	: Fuel injector No. 3
D3	*	(F105)	GY/2	: Fuel injector No. 4

*: Be sure to connect and lock the connectors securely after repair work.
Failure to do so may cause the ECM to have diagnostic trouble codes.
Do not disconnect these connectors except in the case of working according to WORK FLOW of TROUBLE DIAGNOSES in EC and AT sections.

HARNESSES

BODY HARNESS

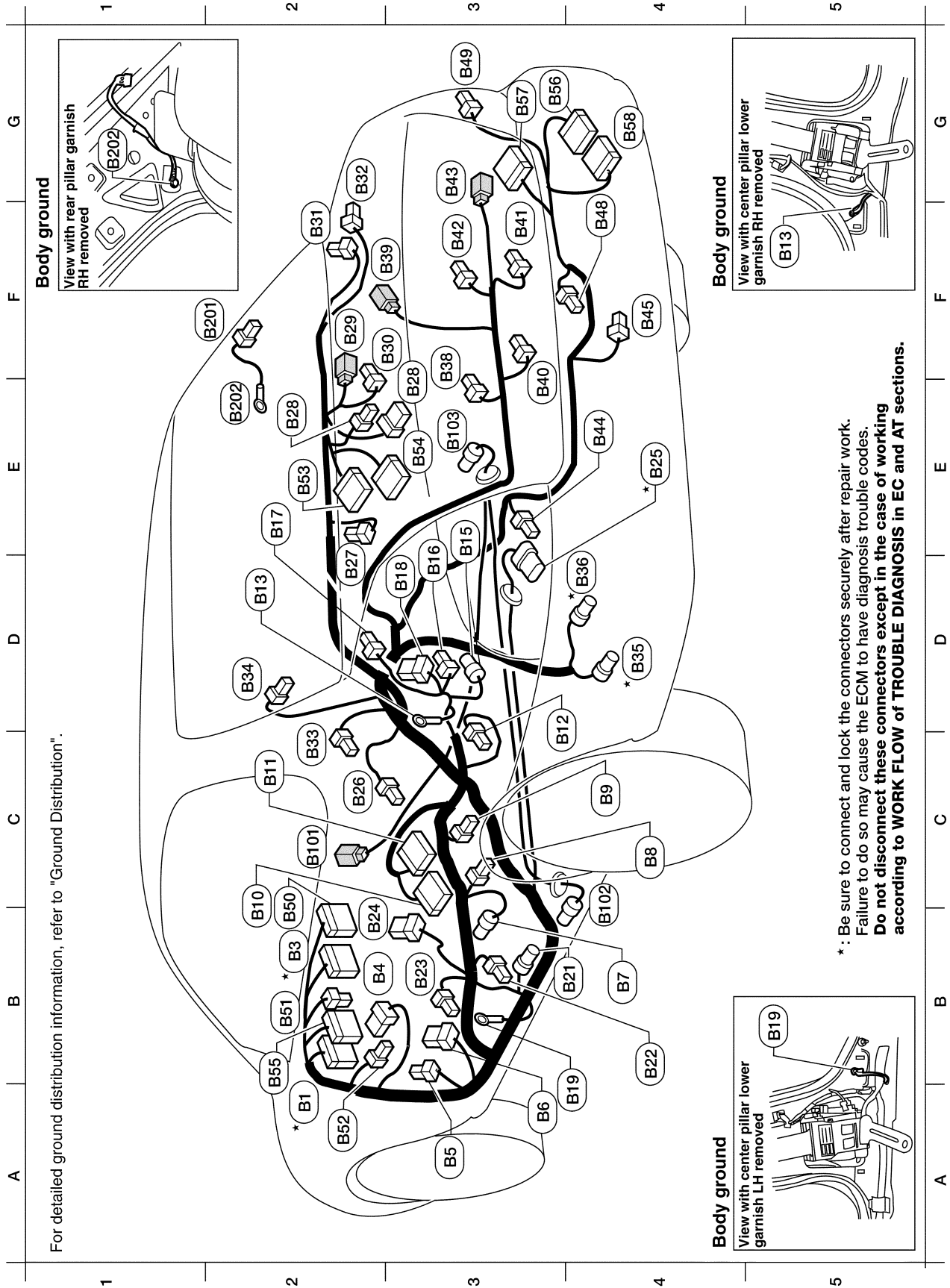

For detailed ground distribution information, refer to "Ground Distribution".

Body ground
View with rear pillar garnish RH removed

Body ground
View with center pillar lower garnish RH removed

Body ground
View with center pillar lower garnish LH removed

*: Be sure to connect and lock the connectors securely after repair work. Failure to do so may cause the ECM to have diagnosis trouble codes. **Do not disconnect these connectors except in the case of working according to WORK FLOW of TROUBLE DIAGNOSIS in EC and AT sections.**

WKIA4599E

Body harness

A2 *	(B1)	BR/16	: To (M14)	G2	(B32)	W/1	: Rear door switch RH
B2 *	(B3)	W/20	: To (M16)	C2	(B33)	W/2	: Diode-4
B2	(B4)	W/8	: Fuse block (J/B)	D2	(B34)	B/1	: Rear window defogger
A3	(B5)	L/4	: Fuel pump relay	D4 *	(B35)	B/2	: EVAP canister vent control valve
A3	(B6)	BR/6	: Rear window defogger relay	D4 *	(B36)	GY/3	: EVAP control system pressure sensor
B4	(B7)	Y/2	: Front LH side air bag module	F3	(B38)	W/2	: Back-up lamp LH
C4	(B8)	W/3	: Seat belt buckle switch LH	F2	(B39)	BR/2	: High-mounted stop lamp (with rear air spoiler)
C4	(B9)	B/1	: Parking brake switch	E3	(B40)	W/2	: License plate lamp LH
C2	(B10)	Y/12	: Air bag diagnosis sensor unit	F3	(B41)	W/2	: License plate lamp RH
C2	(B11)	Y/12	: Air bag diagnosis sensor unit	F3	(B42)	W/2	: Back-up lamp RH
D4	(B12)	Y/2	: Front RH side air bag module	G3	(B43)	W/2	: Trunk lid key cylinder switch (unlock switch) (with vehicle security system)
D2	(B13)	-	: Body ground	E4	(B44)	W/4	: Rear combination lamp LH
E3	(B15)	Y/2	: RH side air bag (satellite) sensor	F4	(B45)	W/4	: Trunk lid opener actuator
E3	(B16)	Y/2	: Front RH seat belt pre-tensioner	F4	(B48)	W/2	: Trunk room lamp switch
E2	(B17)	W/3	: Front door switch RH	G3	(B49)	W/4	: Rear combination lamp RH
D3	(B18)	W/8	: To (D301)	B2	(B50)	W/12	: To (M65)
A4	(B19)	-	: Body ground	B2	(B51)	W/2	: To (M67)
B3	(B21)	Y/2	: LH side air bag (satellite) sensor	A2	(B52)	W/4	: To (D9)
B4	(B22)	Y/2	: Front LH seat belt pre-tensioner	E2	(B53)	W/12	: Audio amplifier (with premium audio system)
B3	(B23)	W/3	: Front door switch LH	E3	(B54)	W/12	: Audio amplifier (with premium audio system)
B2	(B24)	W/8	: To (D201)	B2	(B55)	W/24	: To (M68)
E4 *	(B25)	GY/5	: Fuel level sensor unit and fuel pump	G3	(B56)	W/16	: Satellite radio tuner (pre-wiring type A and B)
C2	(B26)	W/1	: Rear door switch LH	G3	(B57)	W/16	: Satellite radio tuner (pre-wiring type A)
E2	(B27)	BR/2	: Rear speaker LH	G3	(B58)	W/16	: Satellite radio tuner (pre-wiring type B)
E3	(B28)	W/8	: Subwoofer (with mid level audio system)	Body No. 2 harness			
E2	(B28)	W/4	: Subwoofer (with premium audio system)	C2	(E10)	W/4	: To (E56)
F2	(B29)	W/2	: High-mounted stop lamp (without rear air spoiler)	C4	(E102)	BR/2	: Rear wheel sensor LH
F3	(E30)	W/2	: Trunk room lamp	E3	(E103)	GY/2	: Rear wheel sensor RH
F2	(B31)	BR/2	: Rear speaker RH	Rear window defogger ground sub-harness			
				F2	(E201)	B/1	: Rear window defogger
				E2	(E202)	-	: Body ground

* : Be sure to connect and lock the connectors securely after repair work.
Failure to do so may cause the ECM to have diagnostic trouble codes.
Do not disconnect these connectors except in the case of working according to TROUBLE FLOW of TROUBLE DIAGNOSES in EC and AT sections.

WKIA4600E

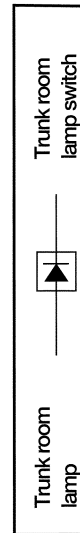

HARNESS

ROOM LAMP HARNESS

- (R1) W/6 : To (M25)
- (R2) W/2 : Vanity lamp LH
- (R3) W/3 : Map lamp
- (R4) B/12 : Sunroof motor assembly
- (R5) - : Body ground
- (R6) W/4 : Sunroof switch
- (R7) W/2 : Vanity lamp RH
- (R8) W/2 : Interior lamp

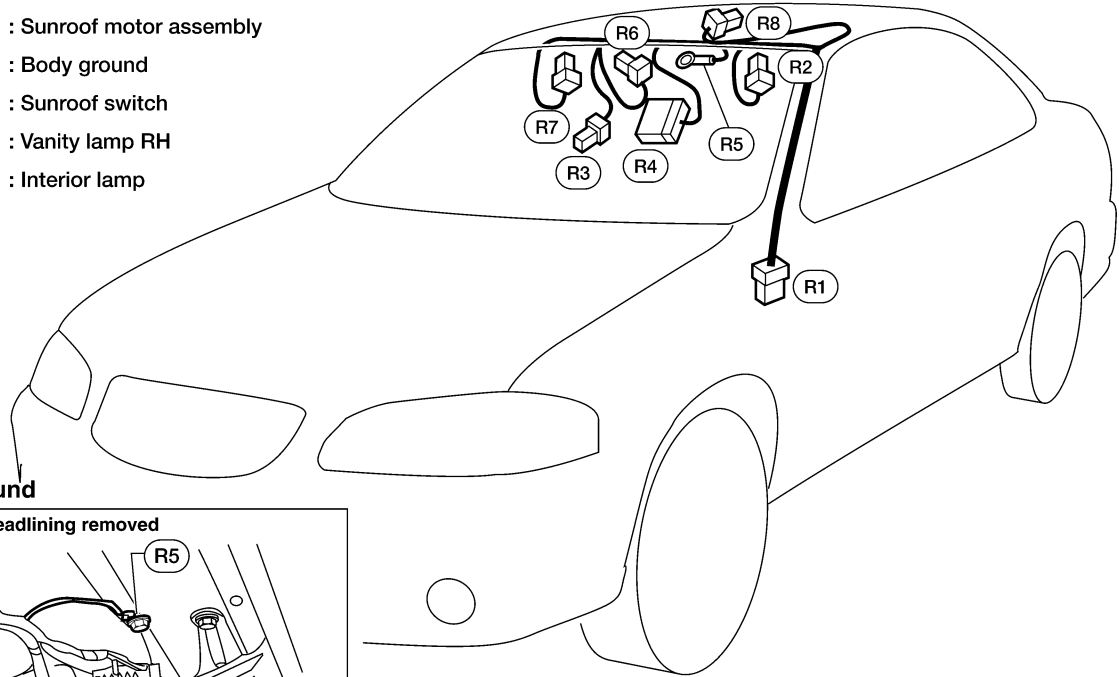

Body ground

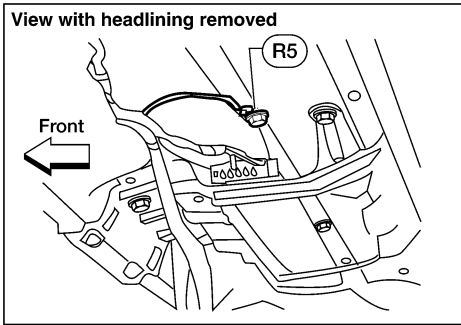

For detailed ground distribution information, refer to "Ground Distribution".

WKIA0380E

A
B
C
D
E
F
G
H
I
J
L
M

PG

HARNESS

FRONT DOOR HARNESS LH SIDE

- ⓁD1 W/8 : To ⓁM4
- ⓁD2 W/16 : To ⓁM5
- ⓁD3 W/2 : Front door speaker LH
- ⓁD4 GY/6 : Door mirror LH
- ⓁD5 B/2 : Front power window motor LH
- ⓁD6 W/16 : Main power window and door lock/unlock switch
- ⓁD7 SB/4 : Front door lock actuator LH
- ⓁD8 BR/3 : Front door key cylinder switch LH
- ⓁD9 W/4 : To ⓁB52

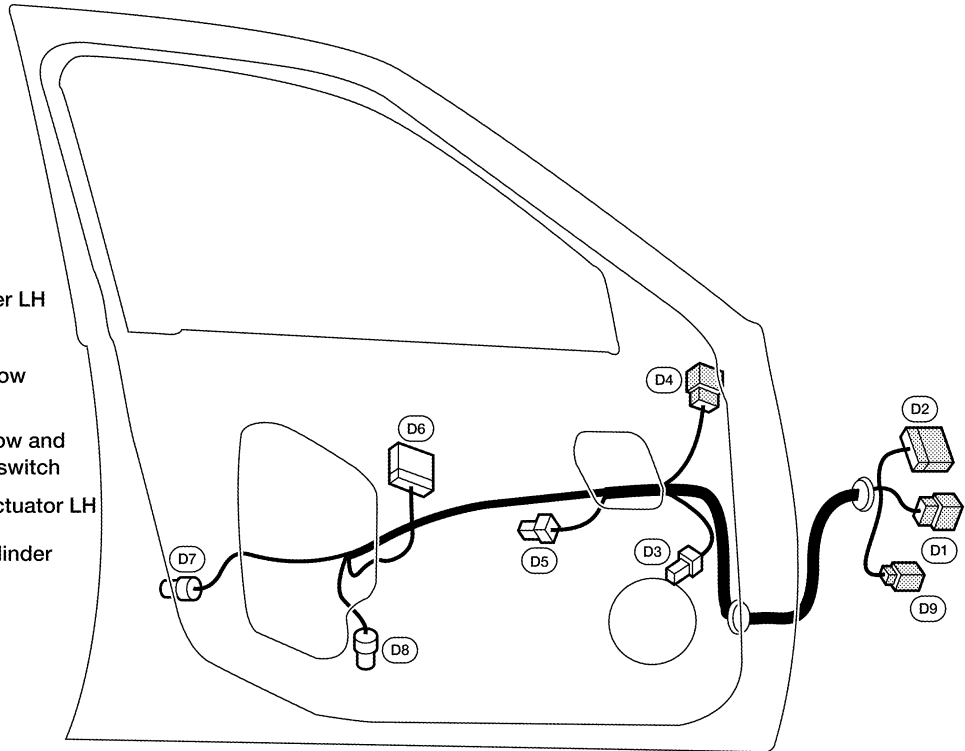

WKIA0977E

RH SIDE

- ⓁD102 W/16: To ⓁM64
- ⓁD103 W/2 : Front door speaker RH
- ⓁD104 GY/6 : Door mirror RH
- ⓁD105 B/2 : Front power window motor RH
- ⓁD106 W/8 : Front power window switch RH
- ⓁD107 GY/8 : Door lock/unlock switch RH
- ⓁD109 SB/4 : Front door lock actuator RH

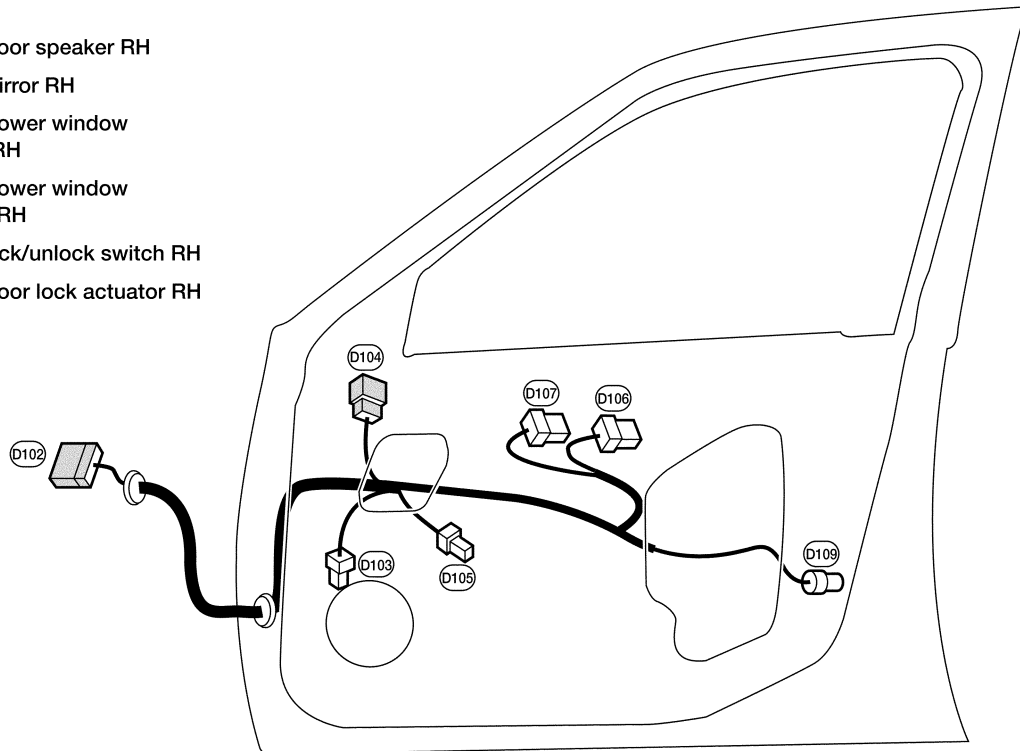

WKIA4603E

HARNESS

REAR DOOR HARNESS LH SIDE

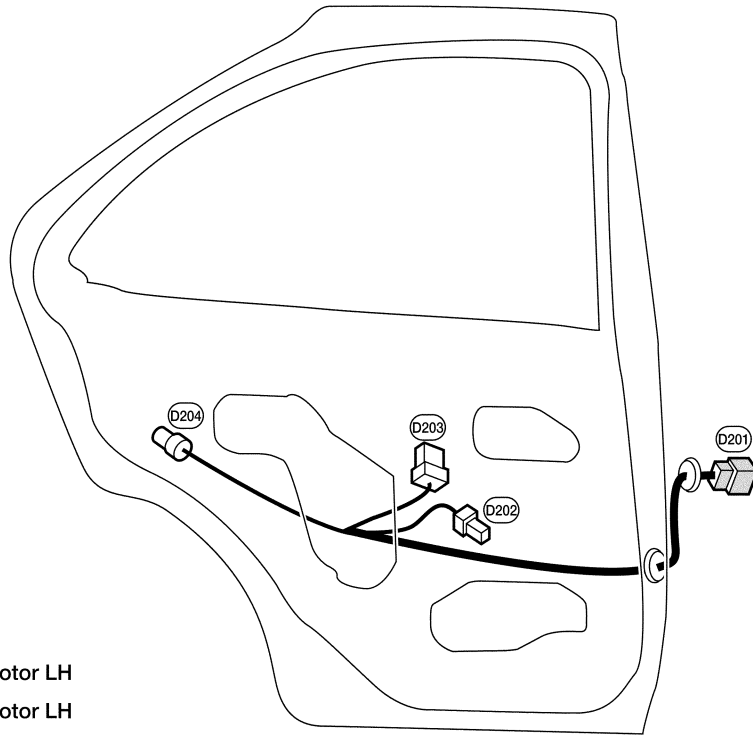

- (D201) W/8 : To (E24)
- (D202) B/2 : Rear power window motor LH
- (D202) GY/2 : Rear power window motor LH
- (D203) W/8 : Rear power window switch LH
- (D204) SB/4 : Rear door lock actuator LH

WKIA4604E

RH SIDE

- (D301) W/8 : To (E18)
- (D302) B/2 : Rear power window motor RH
- (D302) GY/2 : Rear power window motor RH
- (D303) W/8 : Rear power window switch RH
- (D304) SB/4 : Rear door lock actuator RH

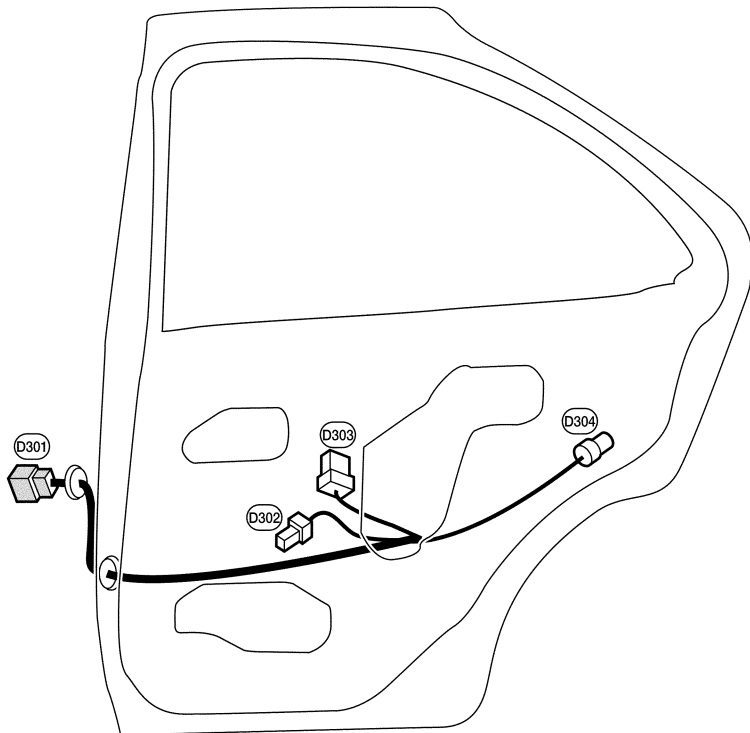

WKIA4605E

A
B
C
D
E
F
G
H
I
J
PG
L
M

HARNESS

Wiring Diagram Codes (Cell Codes)

EKS003B3

Use the chart below to find out what each wiring diagram code stands for.

Refer to the wiring diagram code in the alphabetical index to find the location (page number) of each wiring diagram.

Code	Section	Wiring Diagram Name
1STSIG	AT	A/T 1ST Signal
2NDSIG	AT	A/T 2ND Signal
3RDSIG	AT	A/T 3RD Signal
4THSIG	AT	A/T 4TH Signal
ABS	BRC	Anti-lock Brake System
A/C,M	MTC	Air Conditioner
A/F	EC	Air Fuel Ratio (A/F) Sensor 1
A/FH	EC	Air Fuel Ratio (A/F) Sensor 1 Heater
APPS1	EC	Accelerator Pedal Position Sensor
APPS2	EC	Accelerator Pedal Position Sensor
APPS3	EC	Accelerator Pedal Position Sensor
ASC/BS	EC	ASCD Brake Switch
ASCBOF	EC	ASCD Brake Switch
ASCIND	EC	ASCD Indicator
ASC/SW	EC	ASCD Steering Switch
AUDIO	AV	Audio
B/COMP	DI	Board computer
BACK/L	LT	Back-up Lamp
BA/FTS	AT	A/T Fluid Temperature Sensor and TCM Power Supply
BRK/SW	EC	Brake Switch
CAN	AT	CAN Communication Line
CAN	EC	CAN Communication Line
CAN	LAN	CAN Communication Line
CHARGE	SC	Charging System
CHIME	DI	Warning Chime
CIGAR	WW	Cigarette Lighter
COOL/F	EC	Cooling Fan Control
DEF	GW	Rear Window Defogger
DLC	EC	Data Link Connector
D/LOCK	BL	Power Door Lock
DTRL	LT	Headlamp - With Daytime Light System (For Canada)
ECM/PW	EC	ECM Power Supply For Back-Up
ECTS	EC	Engine Coolant Temperature Sensor
ENGSS	AT	Engine Speed Signal
ETC1	EC	Electric Throttle Control Function
ETC2	EC	Throttle Control Motor Relay
ETC3	EC	Throttle Control Motor
F/FOG	LT	Front Fog Lamp
F/PUMP	EC	Fuel Pump Control
FTS	AT	A/T Fluid Temperature Sensor
FTTS	EC	Fuel Tank Temperature Sensor

HARNESSES

Code	Section	Wiring Diagram Name	
FUEL	EC	Fuel Injection System Function	A
HEATER	MTC	Heater System	
H/LAMP	LT	Headlamp	B
H/MIRR	GW	Heated Mirror	
HO2S1	EC	Heated Oxygen Sensor 1	
HO2S1H	EC	Heated Oxygen Sensor 1 Heater	C
HO2S2	EC	Heated Oxygen Sensor 2	
HO2S2H	EC	Heated Oxygen Sensor 2 Heater	D
HORN	WW	Horn	
IATS	EC	Intake Air Temperature Sensor	
IGNSYS	EC	Ignition Signal	E
ILL	LT	Illumination	
INJECT	EC	Injector	F
INT/L	LT	Interior, Step, Spot, Vanity Mirror and Trunk Room Lamps	
IVC	EC	Intake Valve Timing Control Solenoid Valve	
KEYLES	BL	Remote Keyless Entry System	G
KS	EC	Knock Sensor	
LOAD	EC	Load Signal	H
LPSV	AT	Line Pressure Solenoid Valve	
MAFS	EC	Mass Air Flow Sensor	
MAIN	AT	Main Power Supply and Ground Circuit	I
MAIN	EC	Main Power Supply and Ground Circuit	
METER	DI	Speedometer, Tachometer, Temp., and Fuel Gauges	J
MIL/DL	EC	Malfunction Indicator Lamp and Data Link Connector	
MIRROR	GW	Power Door Mirror	
NATS	BL	NVIS (Nissan Vehicle Immobilizer System — NATS)	PG
NONDTC	AT	Non-detectable Items	
OVRCSV	AT	Overrun Clutch Solenoid Valve	
PGC/V	EC	EVAP Canister Purge Volume Control Solenoid Valve	L
PHASE	EC	Camshaft Position Sensor (PHASE)	
PNP/SW	AT	Park/Neutral Position Switch	M
PNP/SW	EC	Park/Neutral Position Switch	
POS	EC	Crankshaft Position Sensor (POS)	
POWER	PG	Power Supply Routing	
PRE/SE	EC	EVAP Control System Pressure Sensor	
PS/SEN	EC	Power Steering Pressure Sensor	
ROOM/L	LT	Room Lamp	
RP/SEN	EC	Refrigerant Pressure Sensor	
SEN/PW	EC	Sensor Power Supply	
SHIFT	AT	A/T Shift Lock System	
SROOF	RF	Sunroof	
SRS	SRS	Supplemental Restraint System	
SSV/A	AT	Shift Solenoid Valve A	
SSV/B	AT	Shift Solenoid Valve B	

HARNESSES

Code	Section	Wiring Diagram Name
START	SC	Starting System
STOP/L	LT	Stop Lamp
SWL/S	EC	Swirl Control Valve Position Sensor [QG18DE (SULEV)]
SWL/V	EC	Swirl Control Valve [QG18DE (SULEV)]
TAIL/L	LT	Parking, License and Tail Lamps
TCCSIG	AT	A/T TCC Signal (Lock Up)
TCV	AT	Torque Converter Clutch Solenoid Valve
TLID	BL	Trunk Lid Opener
TPS	AT	Throttle Position Sensor
TPS1	EC	Throttle Position Sensor
TPS2	EC	Throttle Position Sensor
TPS3	EC	Throttle Position Sensor
TRSA/T	AT	Turbine Revolution Sensor (QR25DE Model)
TURN	LT	Turn Signal and Hazard Warning Lamps
VIAS	EC	Variable Air Induction Control System (QR25DE Model)
VEHSEC	BL	Vehicle Security System
VENT/V	EC	EVAP Canister Vent Control Valve
VSS	EC	Vehicle Speed Sensor
VSSA/T	AT	Vehicle Speed Sensor A/T (Revolution Sensor)
VSSMTR	AT	Vehicle Speed Sensor MTR
WARN	DI	Warning Lamps
WINDOW	GW	Power Window
WIPER	WW	Front Wiper and Washer

ELECTRICAL UNITS LOCATION

ELECTRICAL UNITS LOCATION

PF25230

Electrical Units Location ENGINE COMPARTMENT

EKS003B4

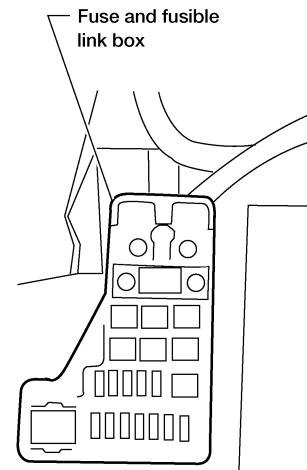
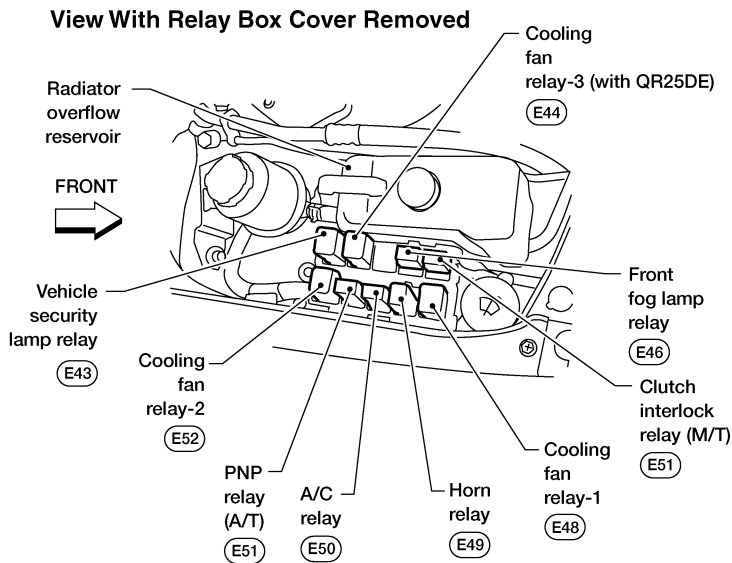
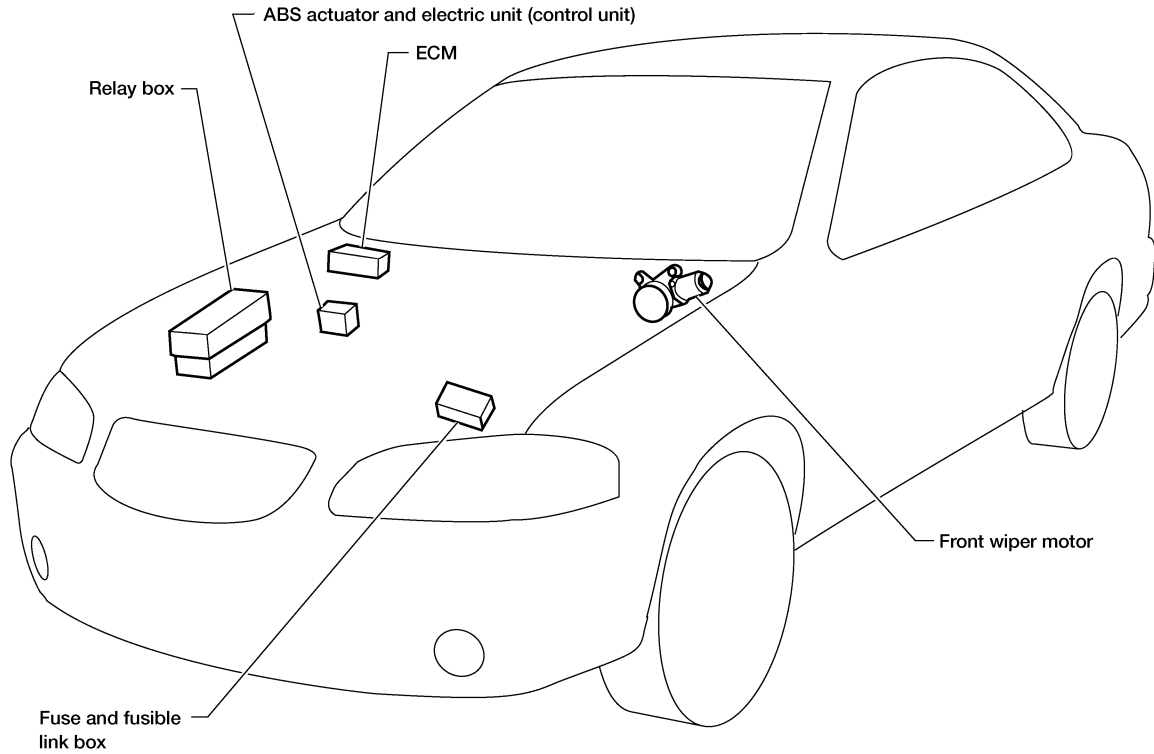

A
B
C
D
E
F
G
H
I
J
PG
L
M

WKIA0980E

ELECTRICAL UNITS LOCATION

PASSENGER COMPARTMENT

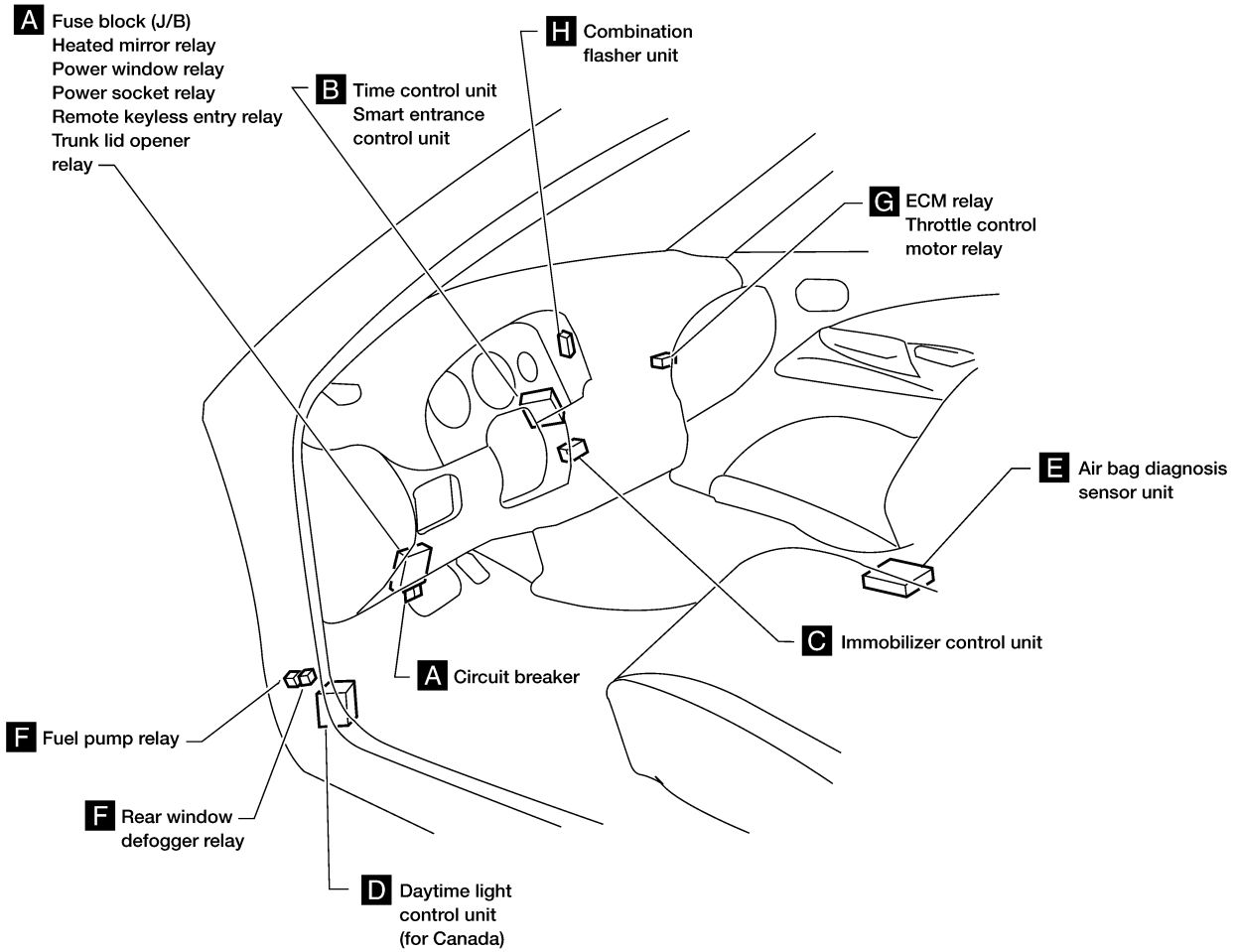

A Instrument panel LH side

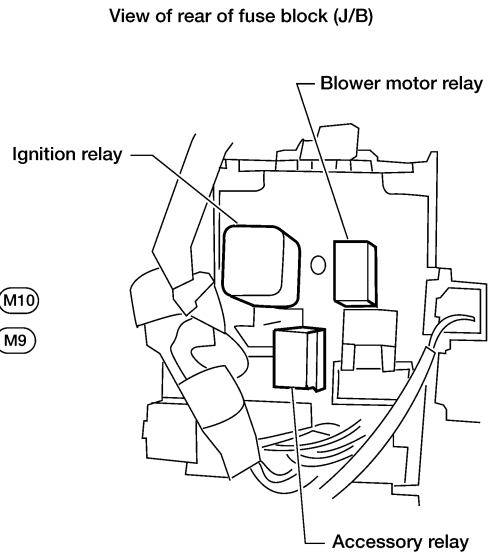
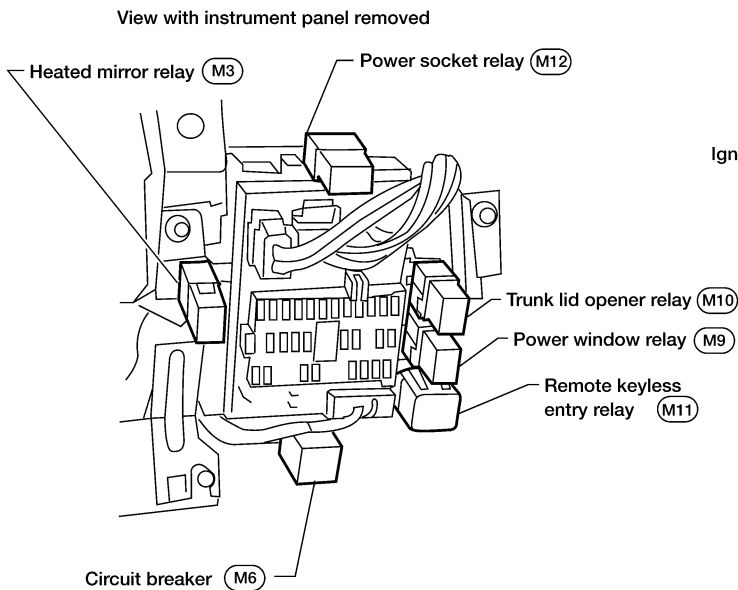

WKIA0249E

ELECTRICAL UNITS LOCATION

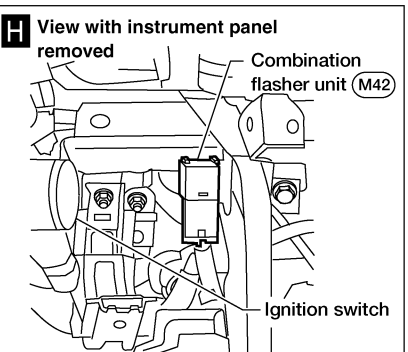
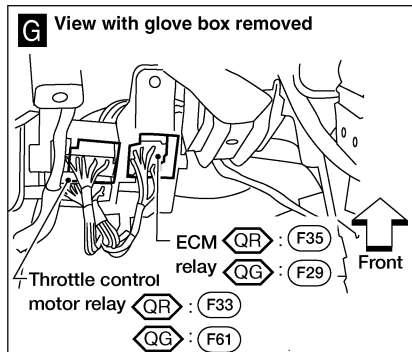
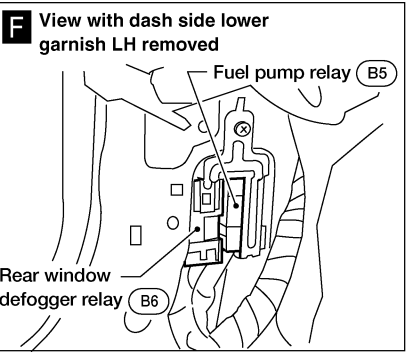
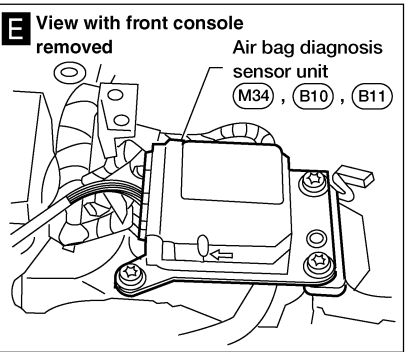
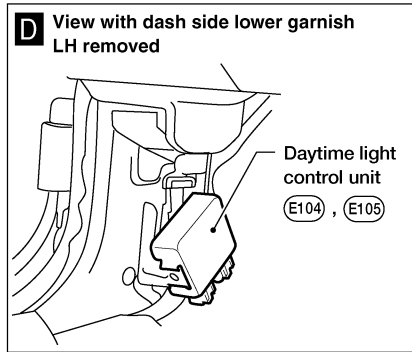
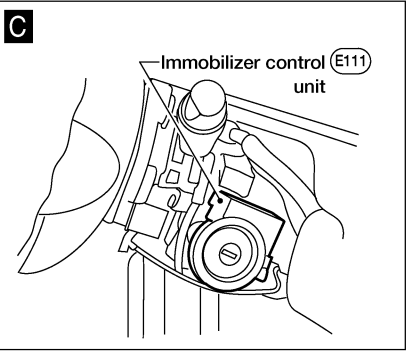
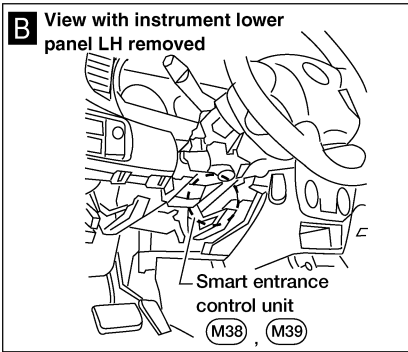
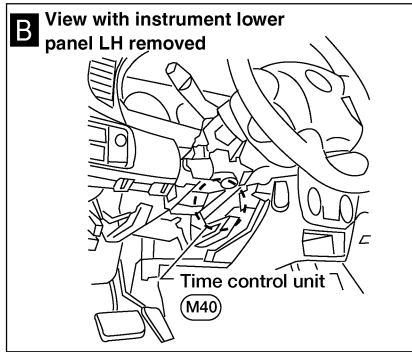

QR : WITH QR25DE
QG : WITH QG18DE

A
B
C
D
E
F
G
H
I
J
L
M

PG

WKIA0981E

ELECTRICAL UNITS LOCATION

Fuse

EKS003B5

- If fuse is blown, be sure to eliminate cause of incident before installing new fuse.
- Use fuse of specified rating. Never use fuse of more than specified rating.
- Do not partially install fuse; always insert it into fuse holder properly.
- Remove fuse for "ELECTRICAL PARTS (BAT)" if vehicle is not used for a long period of time.

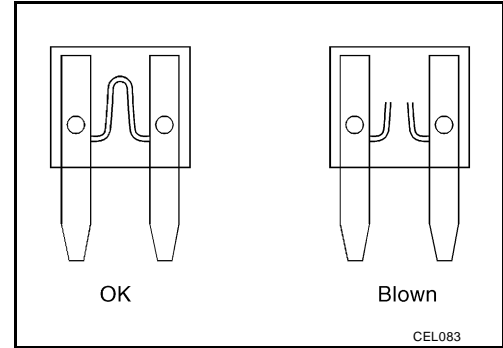

Fusible Link

EKS003B6

A melted fusible link can be detected either by visual inspection or by feeling with finger tip. If its condition is questionable, use circuit tester or test lamp.

CAUTION:

- If fusible link should melt, it is possible that critical circuit (power supply or large current carrying circuit) is shorted. In such a case, carefully check and eliminate cause of incident.
- Never wrap outside of fusible link with vinyl tape. Important: Never let fusible link touch any other wiring harness, vinyl or rubber parts.

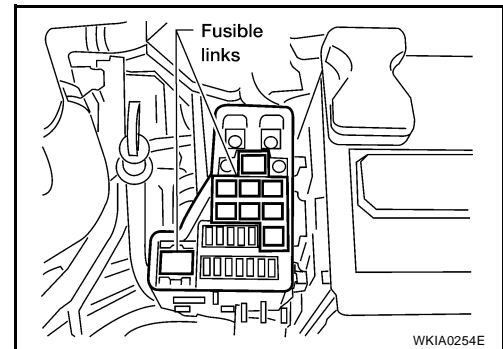

Circuit Breaker

EKS003B7

For example, when current is 30A, the circuit is broken within 8 to 20 seconds.

A circuit breaker is used for the following systems:

- Power door locks
- Power sunroof
- Power windows
- Remote keyless entry system

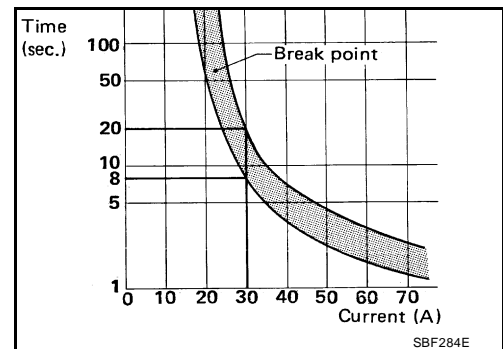

HARNESS CONNECTOR

HARNESS CONNECTOR

PFP:24010

Description

HARNESS CONNECTOR (TAB-LOCKING TYPE)

EKS003B8

- The tab-locking type connectors help prevent accidental looseness or disconnection.
- The tab-locking type connectors are disconnected by pushing or lifting the locking tab(s). Refer to the illustration below.

Refer to the next page for description of the slide-locking type connector.

CAUTION:

Do not pull the harness or wires when disconnecting the connector.

[Example]

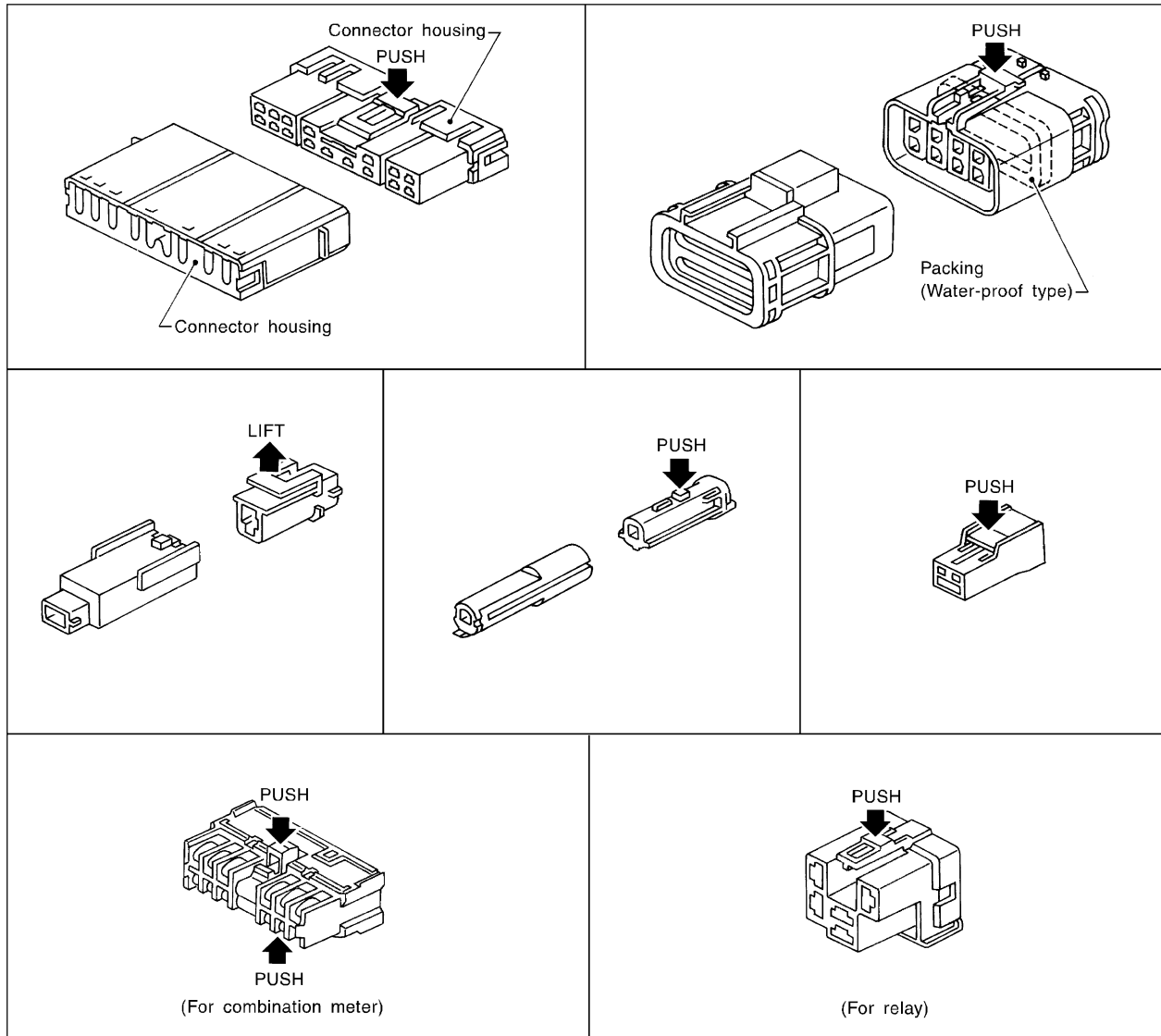

A
B
C
D
E
F
G
H
I
J
L
M

PG

SEL769DA

HARNESS CONNECTOR

HARNESS CONNECTOR (SLIDE-LOCKING TYPE)

- A new style slide-locking type connector is used on certain systems and components, especially those related to OBD.
- The slide-locking type connectors help prevent incomplete locking and accidental looseness or disconnection.
- The slide-locking type connectors are disconnected by pushing or pulling the slider. Refer to the illustration below.

CAUTION:

- Do not pull the harness or wires when disconnecting the connector.
- Be careful not to damage the connector support bracket when disconnecting the connector.

[Example]

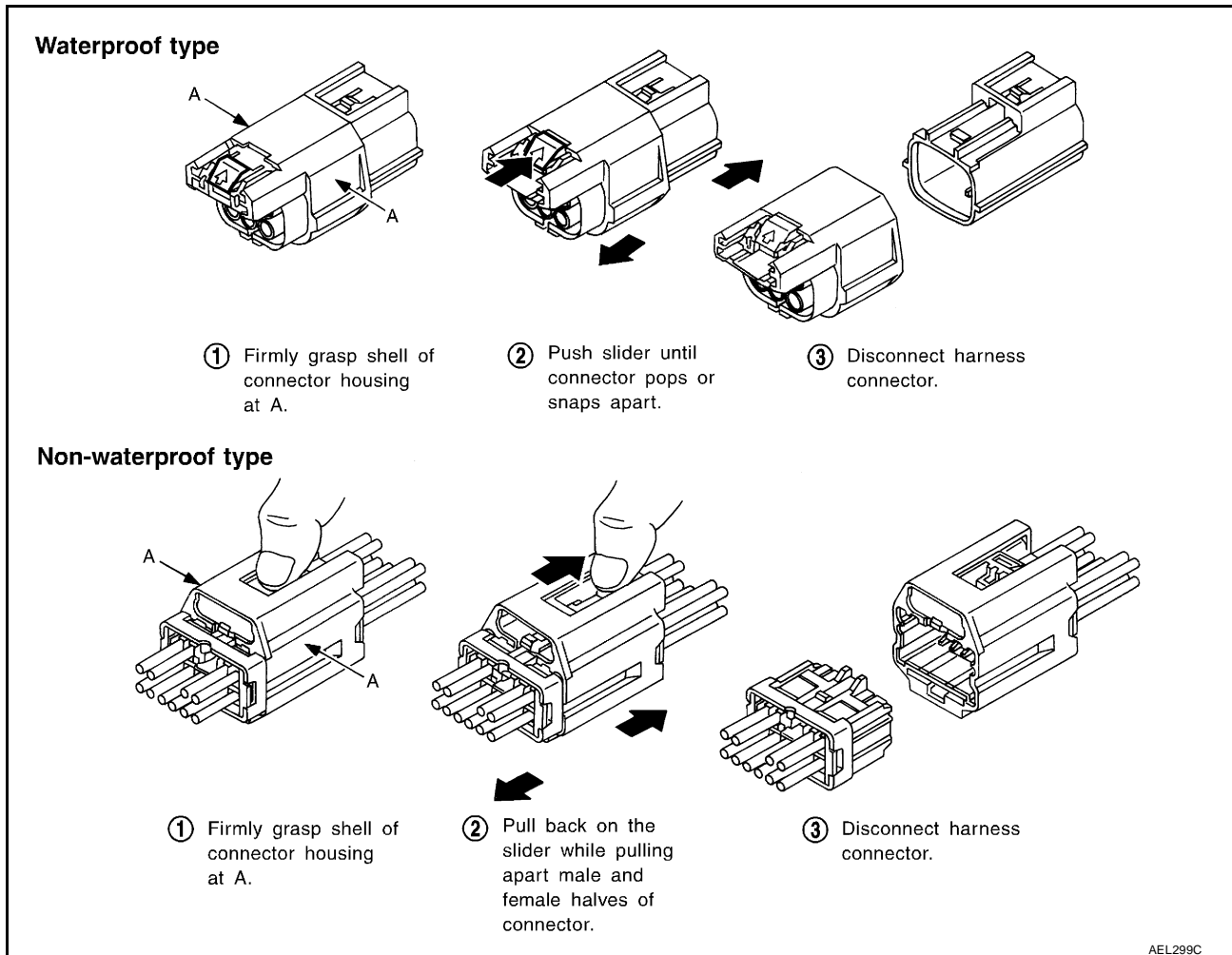

HARNESS CONNECTOR

HARNESS CONNECTOR (DIRECT-CONNECT SRS COMPONENT TYPE)

- SRS direct-connect type harness connectors are used on certain SRS components such as air bag modules and seat belt pre-tensioners.
- Always pull up to release black locking tab prior to removing connector from SRS component.
- Always push down to lock black locking tab after installing connector to SRS component. When locked, the black locking tab is level with the connector housing.

CAUTION:

- **Do not pull the harness or wires when removing connectors from SRS components.**

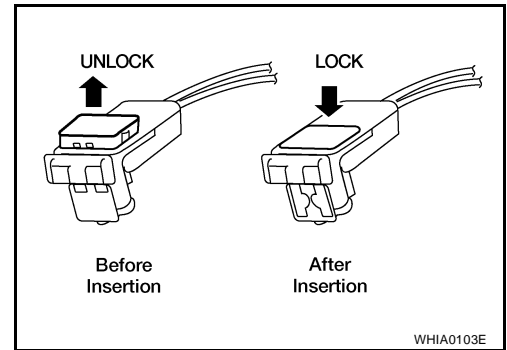

A
B
C
D
E
F
G
H
I
J
L
M

ELECTRICAL UNITS

PF-P:23710

EKS003BA

ELECTRICAL UNITS Terminal Arrangement

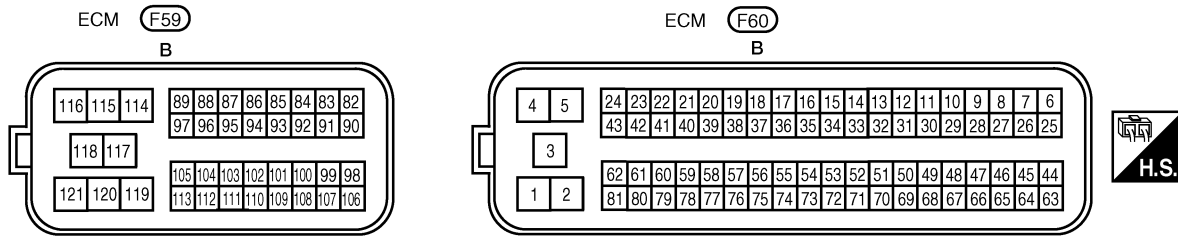

TCM (TRANSMISSION CONTROL MODULE)

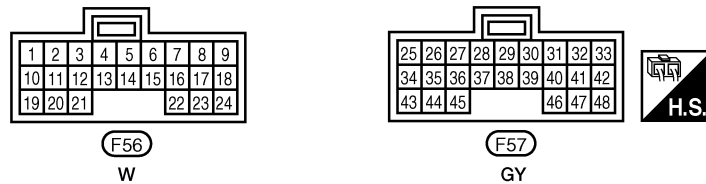

ABS ACTUATOR AND ELECTRIC UNIT
(CONTROL UNIT) (E55)

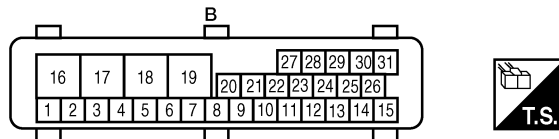

TIME CONTROL UNIT : (OD)

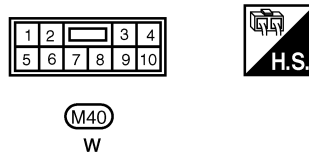

SMART ENTRANCE CONTROL UNIT : (DL)

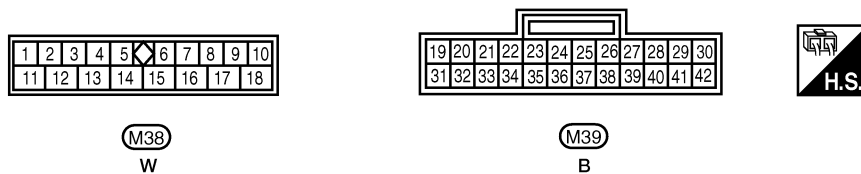

(OD) : WITHOUT POWER DOOR LOCKS
(DL) : WITH POWER DOOR LOCKS

WKIA0983E

STANDARDIZED RELAY

PFP:25230

EKS003BB

STANDARDIZED RELAY

Description

NORMAL OPEN, NORMAL CLOSED AND MIXED TYPE RELAYS

Relays can mainly be divided into three types: normal open, normal closed and mixed type relays.

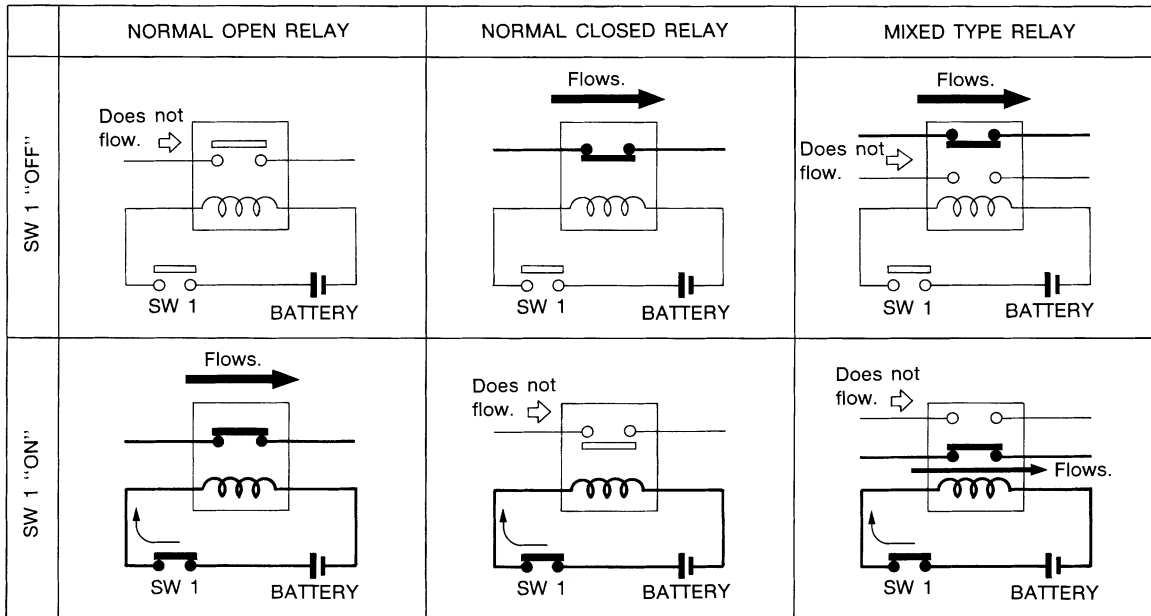

SEL881H

TYPE OF STANDARDIZED RELAYS

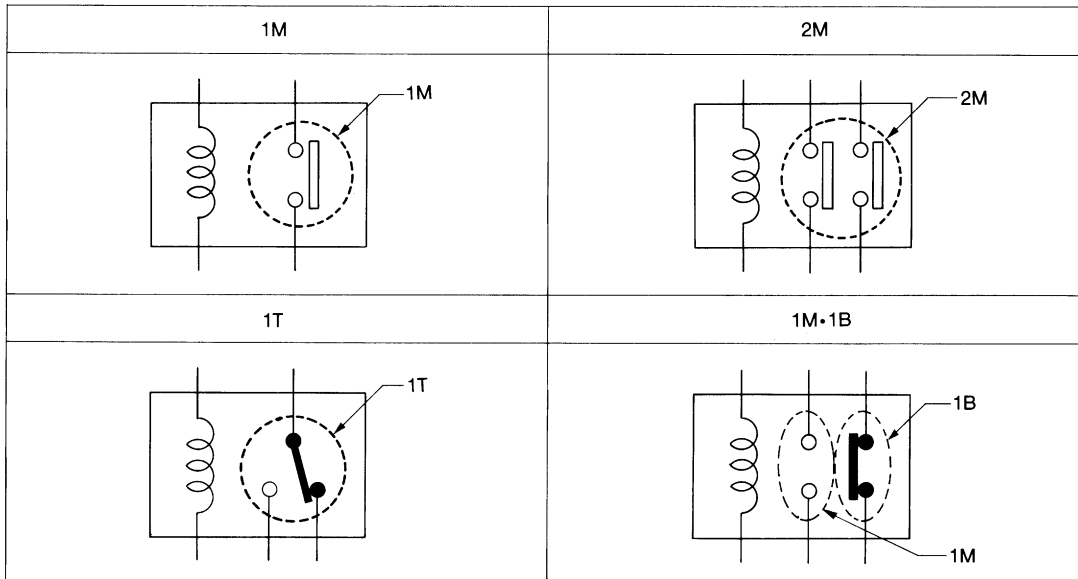

SEL882H

1M	1 Make	2M	2 Make
1T	1 Transfer	1M•1B	1 Make 1 Break

STANDARDIZED RELAY

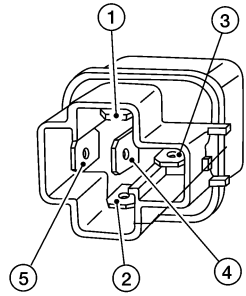
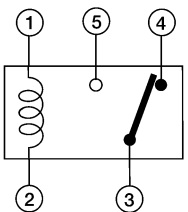
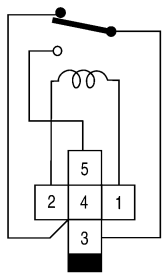
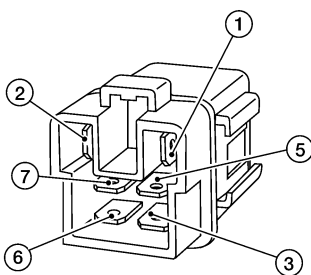
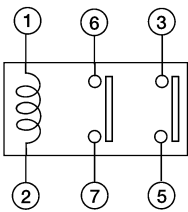
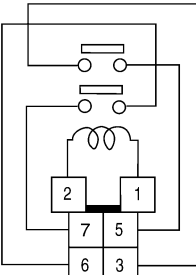
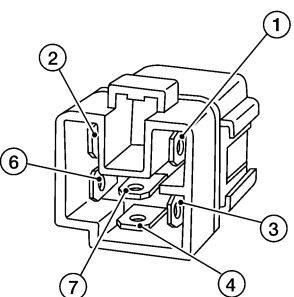
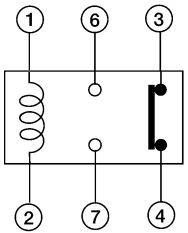
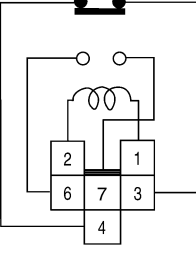
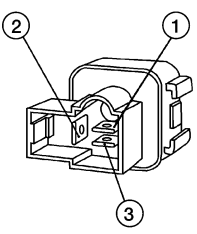
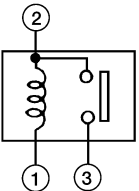
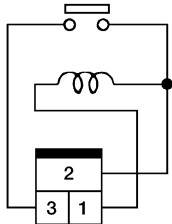
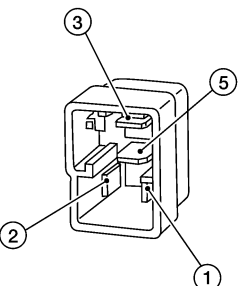
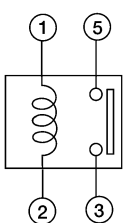
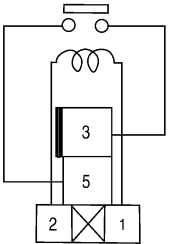
Type	Outer view	Circuit	Connector Symbol and connection	Case color
1T				BLACK
2M				BROWN
1M-1B				GRAY
1M				BLACK
				BLUE

The arrangement of terminal numbers on the actual relays may differ from those shown above.

WKIA0253E

FUSE BLOCK — JUNCTION BOX (J/B)

FUSE BLOCK — JUNCTION BOX (J/B) Terminal Arrangement

PF24350

EKS003BC

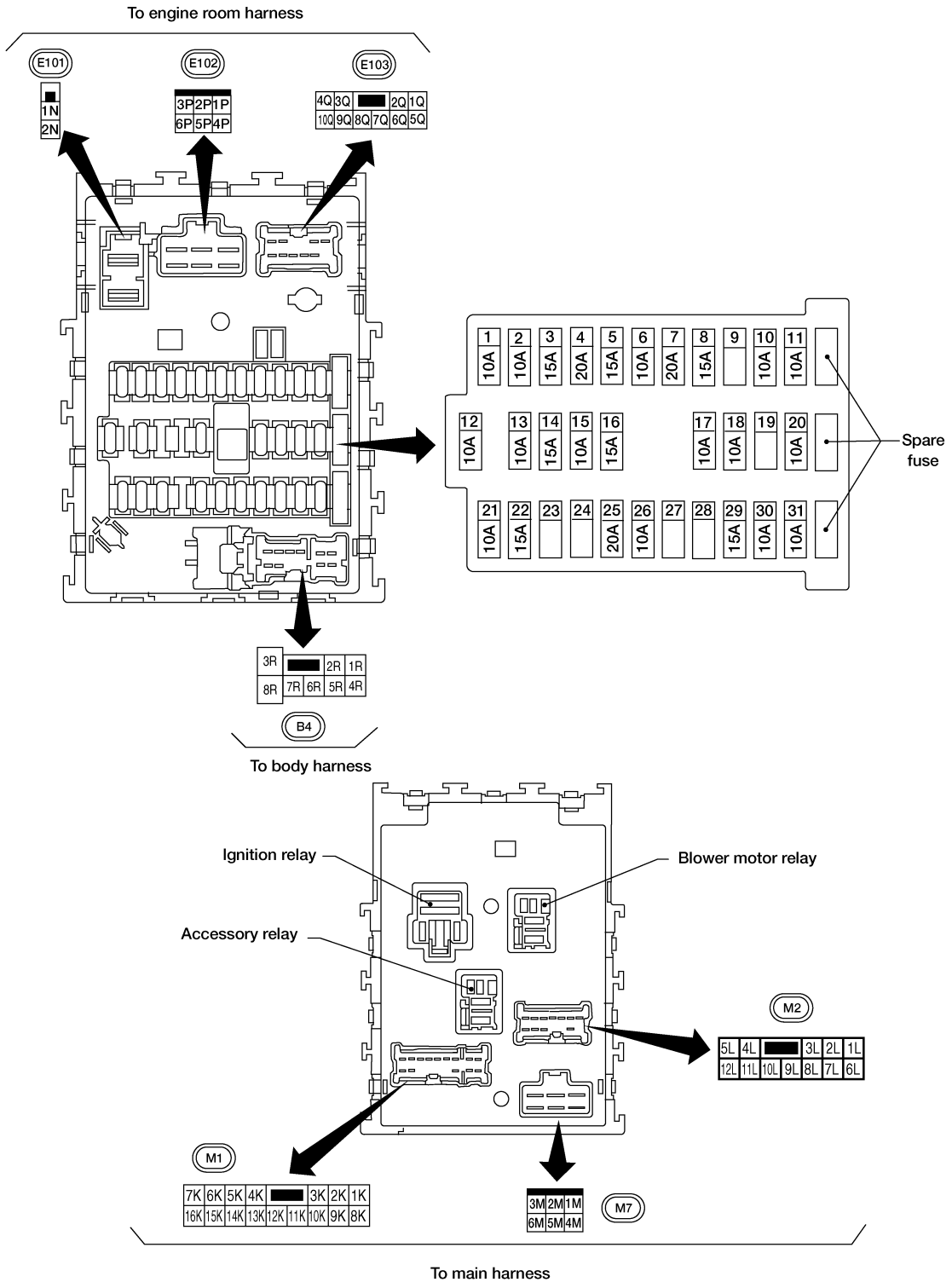

A
B
C
D
E
F
G
H
I
J

PG

L
M

WKIA0984E



FUSE AND FUSIBLE LINK BOX

FUSE AND FUSIBLE LINK BOX

PFP:24381

Terminal Arrangement

EKS003BD

 : With QG18DE
 : With QR25DE

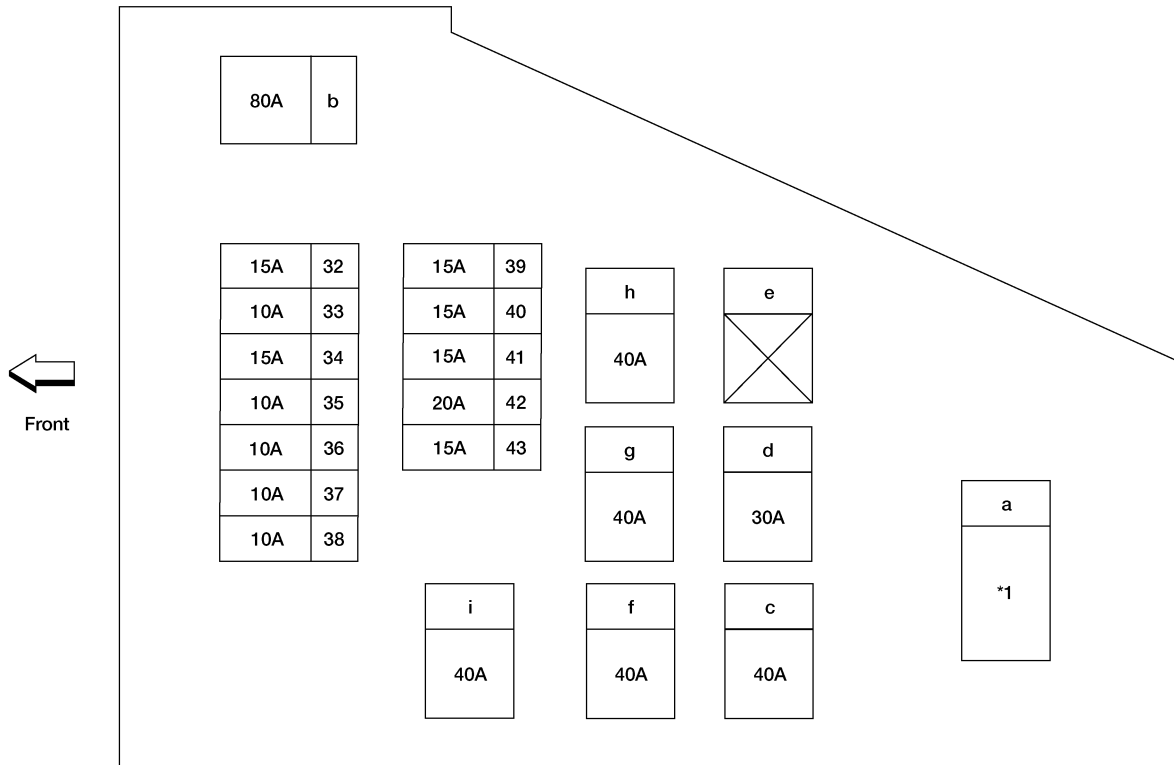

No. 32 - 43 : FUSE

a - i : FUSIBLE LINK

*1  : 100A
 : 120A

WKIA0985E