

**SECTION EI**  
**EXTERIOR & INTERIOR**

A  
B  
C  
D  
E  
F  
G  
H  
EI  
J  
K  
L  
M

**CONTENTS**

<b>PRECAUTIONS</b> .....	<b>2</b>	<b>SEATS</b> .....	<b>7</b>
Precautions for Supplemental Restraint System (SRS) "AIR BAG" and "SEAT BELT PRE-TENSIONER" .....	2	<b>UNDERHOOD</b> .....	7
<b>PREPARATION</b> .....	<b>3</b>	Diagnostic Worksheet .....	8
Special Service Tools .....	3	<b>CLIP AND FASTENER</b> .....	<b>10</b>
Commercial Service Tools .....	3	Description .....	10
<b>SQUEAK AND RATTLE TROUBLE DIAGNOSES</b> .....	<b>4</b>	<b>BODY FRONT END</b> .....	<b>13</b>
Work Flow .....	4	Removal and Installation .....	13
CUSTOMER INTERVIEW .....	4	FRONT BUMPER ASSEMBLY .....	13
DUPLICATE THE NOISE AND TEST DRIVE .....	5	<b>BODY REAR END AND OPENER</b> .....	<b>18</b>
CHECK RELATED SERVICE BULLETINS .....	5	Removal and Installation .....	18
LOCATE THE NOISE AND IDENTIFY THE ROOT CAUSE .....	5	REAR BUMPER ASSEMBLY .....	18
REPAIR THE CAUSE .....	5	<b>WINDSHIELD MOLDING</b> .....	<b>21</b>
CONFIRM THE REPAIR .....	6	Windshield and Rear Window .....	21
Generic Squeak and Rattle Troubleshooting .....	6	<b>EXTERIOR</b> .....	<b>22</b>
INSTRUMENT PANEL .....	6	Removal and Installation .....	22
CENTER CONSOLE .....	6	<b>SIDE AND FLOOR TRIM</b> .....	<b>28</b>
DOORS .....	6	Removal and Installation .....	28
TRUNK .....	7	<b>DOOR FINISHER</b> .....	<b>31</b>
SUNROOF/HEADLINER .....	7	Removal and Installation .....	31
OVERHEAD CONSOLE (FRONT AND REAR).....	7	<b>ROOF TRIM</b> .....	<b>32</b>
		Removal and Installation .....	32
		<b>TRUNK ROOM TRIM</b> .....	<b>33</b>
		Removal and Installation .....	33

# PRECAUTIONS

---

## PRECAUTIONS

PF0:00001

### Precautions for Supplemental Restraint System (SRS) “AIR BAG” and “SEAT BELT PRE-TENSIONER”

EIS001EH

The Supplemental Restraint System such as “AIR BAG” and “SEAT BELT PRE-TENSIONER”, used along with a front seat belt, helps to reduce the risk or severity of injury to the driver and front passenger for certain types of collision. Information necessary to service the system safely is included in the SRS and SB section of this Service Manual.

**WARNING:**

- To avoid rendering the SRS inoperative, which could increase the risk of personal injury or death in the event of a collision which would result in air bag inflation, all maintenance must be performed by an authorized NISSAN/INFINITI dealer.
- Improper maintenance, including incorrect removal and installation of the SRS, can lead to personal injury caused by unintentional activation of the system. For removal of Spiral Cable and Air Bag Module, see the SRS section.
- Do not use electrical test equipment on any circuit related to the SRS unless instructed to in this Service Manual. SRS wiring harnesses can be identified by yellow and/or orange harnesses or harness connectors.

# PREPARATION

## PREPARATION

PFP:00002

### Special Service Tools

EIS0016R

The actual shapes of Kent-Moore tools may differ from those of special service tools illustrated here.

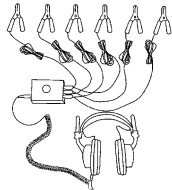
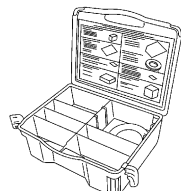
Tool number (Kent-Moore No.) Tool name	Description
— (J-39570) Chassis ear	 <p style="text-align: center;">SIIA0993E</p> Locating the noise
— (J-43980) NISSAN Squeak and Rattle kit	 <p style="text-align: center;">SIIA0994E</p> Repairing the cause of noise

### Commercial Service Tools

EIS0016S

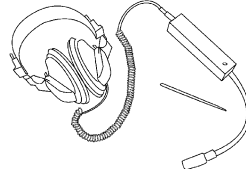
Tool name (Kent-Moore No.)	Description
Engine ear (J-39565)	 <p style="text-align: center;">SIIA0995E</p> Locating the noise

A  
B  
C  
D  
E  
F  
G  
H  
EI  
J  
K  
L  
M

# SQUEAK AND RATTLE TROUBLE DIAGNOSES

## SQUEAK AND RATTLE TROUBLE DIAGNOSES

PF0:00003

### Work Flow

EIS0016T

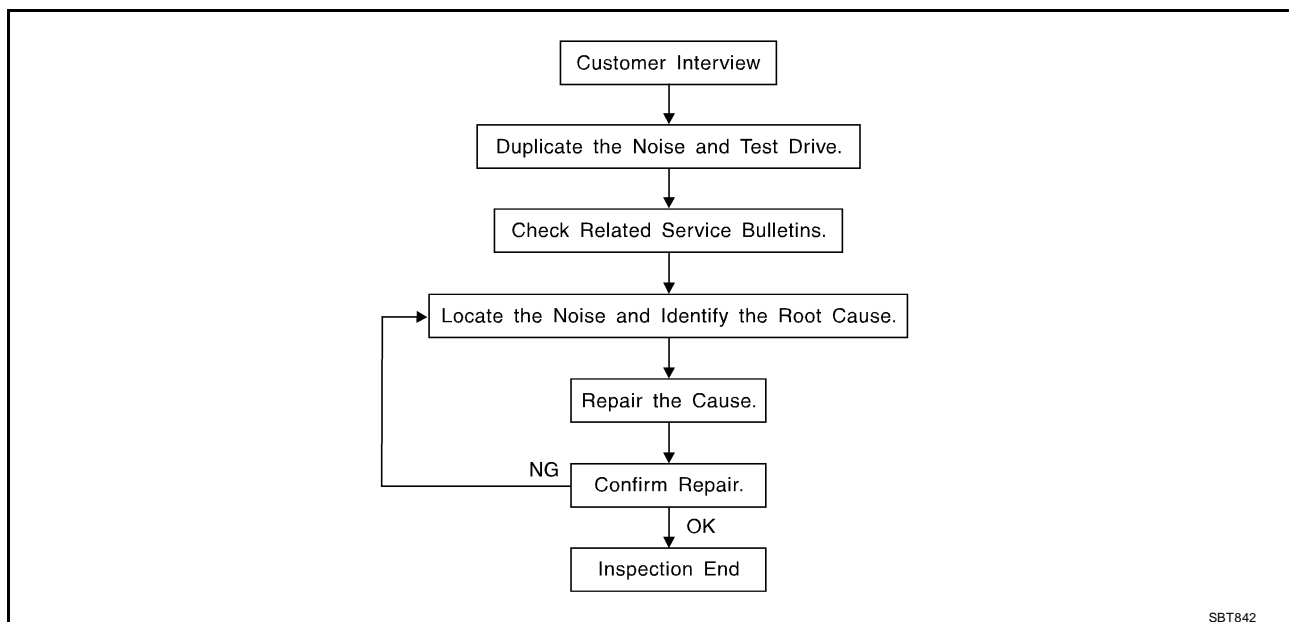

### CUSTOMER INTERVIEW

Interview the customer, if possible, to determine the conditions that exist when the noise occurs. Use the Diagnostic Worksheet during the interview to document the facts and conditions when the noise occurs and any customer's comments; refer to [EI-8, "Diagnostic Worksheet"](#). This information is necessary to duplicate the conditions that exist when the noise occurs.

- The customer may not be able to provide a detailed description or the location of the noise. Attempt to obtain all the facts and conditions that exist when the noise occurs (or does not occur).
- If there is more than one noise in the vehicle, be sure to diagnose and repair the noise that the customer is concerned about. This can be accomplished by test driving the vehicle with the customer.
- After identifying the type of noise, isolate the noise in terms of its characteristics. The noise characteristics are provided so the customer, service adviser and technician are all speaking the same language when defining the noise.
- Squeak — (Like tennis shoes on a clean floor)  
Squeak characteristics include the light contact/fast movement/brought on by road conditions/hard surfaces = higher pitch noise/softer surfaces = lower pitch noises/edge to surface = chirping
- Creak — (Like walking on an old wooden floor)  
Creak characteristics include firm contact/slow movement/twisting with a rotational movement/pitch dependent on materials/often brought on by activity.
- Rattle — (Like shaking a baby rattle)  
Rattle characteristics include the fast repeated contact/vibration or similar movement/loose parts/missing clip or fastener/incorrect clearance.
- Knock — (Like a knock on a door)  
Knock characteristics include hollow sounding/sometimes repeating/often brought on by driver action.
- Tick — (Like a clock second hand)  
Tick characteristics include gentle contacting of light materials/loose components/can be caused by driver action or road conditions.
- Thump — (Heavy, muffled knock noise)  
Thump characteristics include softer knock/dead sound often brought on by activity.
- Buzz — (Like a bumblebee)  
Buzz characteristics include high frequency rattle/firm contact.
- Often the degree of acceptable noise level will vary depending upon the person. A noise that you may judge as acceptable may be very irritating to the customer.
- Weather conditions, especially humidity and temperature, may have a great effect on noise level.

# SQUEAK AND RATTLE TROUBLE DIAGNOSES

## DUPLICATE THE NOISE AND TEST DRIVE

If possible, drive the vehicle with the customer until the noise is duplicated. Note any additional information on the Diagnostic Worksheet regarding the conditions or location of the noise. This information can be used to duplicate the same conditions when you confirm the repair.

If the noise can be duplicated easily during the test drive, to help identify the source of the noise, try to duplicate the noise with the vehicle stopped by doing one or all of the following:

- Close a door.
- Tap or push/pull around the area where the noise appears to be coming from.
- Rev the engine.
- Use a floor jack to recreate vehicle "twist".
- At idle, apply engine load (electrical load, half-clutch on M/T model, drive position on A/T model).
- Raise the vehicle on a hoist and hit a tire with a rubber hammer.
- Drive the vehicle and attempt to duplicate the conditions the customer states exist when the noise occurs.
- If it is difficult to duplicate the noise, drive the vehicle slowly on an undulating or rough road to stress the vehicle body.

## CHECK RELATED SERVICE BULLETINS

After verifying the customer concern or symptom, check ASIST for Technical Service Bulletins (TSBs) related to that concern or symptom.

If a TSB relates to the symptom, follow the procedure to repair the noise.

## LOCATE THE NOISE AND IDENTIFY THE ROOT CAUSE

1. Narrow down the noise to a general area. To help pinpoint the source of the noise, use a listening tool (Chassis Ear: J-39570, Engine Ear: J-39565 and mechanics stethoscope).
2. Narrow down the noise to a more specific area and identify the cause of the noise by:
  - Removing the components in the area that you suspect the noise is coming from.  
**Do not use too much force when removing clips and fasteners, otherwise clips and fasteners can be broken or lost during the repair, resulting in the creation of new noise.**
  - Tapping or pushing/pulling the component that you suspect is causing the noise.  
**Do not tap or push/pull the component with excessive force, otherwise the noise will be eliminated only temporarily.**
  - Feeling for a vibration with your hand by touching the component(s) that you suspect is (are) causing the noise.
  - Placing a piece of paper between components that you suspect are causing the noise.
  - Looking for loose components and contact marks.

Refer to [EI-6, "Generic Squeak and Rattle Troubleshooting"](#).

## REPAIR THE CAUSE

- If the cause is a loose component, tighten the component securely.
- If the cause is insufficient clearance between components:
  - Separate components by repositioning or loosening and retightening the component, if possible.
  - Insulate components with a suitable insulator such as urethane pads, foam blocks, felt cloth tape or urethane tape. A NISSAN Squeak and Rattle Kit (J-43980) is available through your authorized NISSAN Parts Department.

### CAUTION:

**Do not use excessive force as many components are constructed of plastic and may be damaged. Always check with the Parts Department for the latest parts information.**

The following materials are contained in the NISSAN Squeak and Rattle Kit (J-43980). Each item can be ordered separately as needed.

URETHANE PADS [1.5 mm (0.059 in) thick]

Insulates connectors, harness, etc.

76268-9E005: 100 x 135 mm (3.94 x 5.31 in)/76884-71L01: 60 x 85 mm (2.36 x 3.35 in)/76884-71L02: 15 x 25 mm (0.59 x 0.98 in)

INSULATOR (Foam blocks)

Insulates components from contact. Can be used to fill space behind a panel.

# SQUEAK AND RATTLE TROUBLE DIAGNOSES

73982-9E000: 45 mm (1.77 in) thick, 50 x 50 mm (1.97 x 1.97 in)/73982-50Y00: 10 mm (0.39 in) thick, 50 x 50 mm (1.97 x 1.97 in)

INSULATOR (Light foam block)

80845-71L00: 30 mm (1.18 in) thick, 30 x 50 mm (1.18 x 1.97 in)

FELT CLOTH TAPE

Used to insulate where movement does not occur. Ideal for instrument panel applications.

68370-4B000: 15 x 25 mm (0.59 x 0.98 in) pad/68239-13E00: 5 mm (0.20 in) wide tape roll

The following materials, not found in the kit, can also be used to repair squeaks and rattles.

UHMW (TEFLON) TAPE

Insulates where slight movement is present. Ideal for instrument panel applications.

SILICONE GREASE

Used in place of UHMW tape that will be visible or not fit.

Note: Will only last a few months.

SILICONE SPRAY

Use when grease cannot be applied.

DUCT TAPE

Use to eliminate movement.

## CONFIRM THE REPAIR

Confirm that the cause of a noise is repaired by test driving the vehicle. Operate the vehicle under the same conditions as when the noise originally occurred. Refer to the notes on the Diagnostic Worksheet.

## Generic Squeak and Rattle Troubleshooting

EIS0016U

Refer to Table of Contents for specific component removal and installation information.

### INSTRUMENT PANEL

Most incidents are caused by contact and movement between:

1. The cluster lid A and instrument panel
2. Acrylic lens and combination meter housing
3. Instrument panel to front pillar garnish
4. Instrument panel to windshield
5. Instrument panel mounting pins
6. Wiring harnesses behind the combination meter
7. A/C defroster duct and duct joint

These incidents can usually be located by tapping or moving the components to duplicate the noise or by pressing on the components while driving to stop the noise. Most of these incidents can be repaired by applying felt cloth tape or silicone spray (in hard to reach areas). Urethane pads can be used to insulate wiring harness.

#### CAUTION:

**Do not use silicone spray to isolate a squeak or rattle. If you saturate the area with silicone, you will not be able to recheck the repair.**

### CENTER CONSOLE

Components to pay attention to include:

1. Shifter assembly cover to finisher
2. A/C control unit and upper/lower cluster lid C
3. Wiring harnesses behind audio and A/C control unit

The instrument panel repair and isolation procedures also apply to the center console.

### DOORS

Pay attention to the:

1. Finisher and inner panel making a slapping noise
2. Inside handle escutcheon to door finisher
3. Wiring harnesses tapping
4. Door striker out of alignment causing a popping noise on starts and stops

# SQUEAK AND RATTLE TROUBLE DIAGNOSES

Tapping or moving the components or pressing on them while driving to duplicate the conditions can isolate many of these incidents. You can usually insulate the areas with felt cloth tape or insulator foam blocks from the NISSAN Squeak and Rattle Kit (J-43980) to repair the noise.

A

## TRUNK

Trunk noises are often caused by a loose jack or loose items put into the trunk by the owner.

B

In addition look for:

1. Trunk lid bumpers out of adjustment
2. Trunk lid striker out of adjustment
3. The trunk lid torsion bars knocking together
4. A loose license plate or bracket

C

Most of these incidents can be repaired by adjusting, securing or insulating the item(s) or component(s) causing the noise.

D

## SUNROOF/HEADLINER

Noises in the sunroof/headliner area can often be traced to one of the following:

1. Sunroof lid, rail, linkage or seals making a rattle or light knocking noise
2. Sunvisor shaft shaking in the holder
3. Front or rear windshield touching headliner and squeaking

E

Again, pressing on the components to stop the noise while duplicating the conditions can isolate most of these incidents. Repairs usually consist of insulating with felt cloth tape.

F

G

## OVERHEAD CONSOLE (FRONT AND REAR)

Overhead console noises are often caused by the console panel clips not being engaged correctly. Most of these incidents are repaired by pushing up on the console at the clip locations until the clips engage.

H

In addition look for:

1. Loose harness or harness connectors.
2. Front console map/reading lamp lens loose.
3. Loose screws at console attachment points.

EI

## SEATS

When isolating seat noises it is important to note the position the seat is in and the load placed on the seat when the noise is present. These conditions should be duplicated when verifying and isolating the cause of the noise.

J

Cause of seat noise include:

1. Headrest rods and holders
2. A squeak between the seat pad cushion and frame
3. The rear seat back lock and bracket

K

L

These noises can be isolated by moving or pressing on the suspected components while duplicating the conditions under which the noise occurs. Most of these incidents can be repaired by repositioning the component or applying urethane tape to the contact area.

M

## UNDERHOOD

Some interior noises may be caused by components under the hood or on the engine wall. The noise is then transmitted into the passenger compartment.

Causes of transmitted underhood noises include:

1. Any component mounted to the engine wall
2. Components that pass through the engine wall
3. Engine wall mounts and connectors
4. Loose radiator mounting pins
5. Hood bumpers out of adjustment
6. Hood striker out of adjustment

These noises can be difficult to isolate since they cannot be reached from the interior of the vehicle. The best method is to secure, move or insulate one component at a time and test drive the vehicle. Also, engine RPM or load can be changed to isolate the noise. Repairs can usually be made by moving, adjusting, securing, or insulating the component causing the noise.

# SQUEAK AND RATTLE TROUBLE DIAGNOSES

## Diagnostic Worksheet

EIS0016V



### SQUEAK & RATTLE DIAGNOSTIC WORKSHEET

Dear Nissan Customer:

We are concerned about your satisfaction with your Nissan vehicle. Repairing a squeak or rattle sometimes can be very difficult. To help us fix your Nissan right the first time, please take a moment to note the area of the vehicle where the squeak or rattle occurs and under what conditions. You may be asked to take a test drive with a service advisor or technician to ensure we confirm the noise you are hearing.

#### I. WHERE DOES THE NOISE COME FROM? (circle the area of the vehicle)

The illustrations are for reference only, and may not reflect the actual configuration of your vehicle.

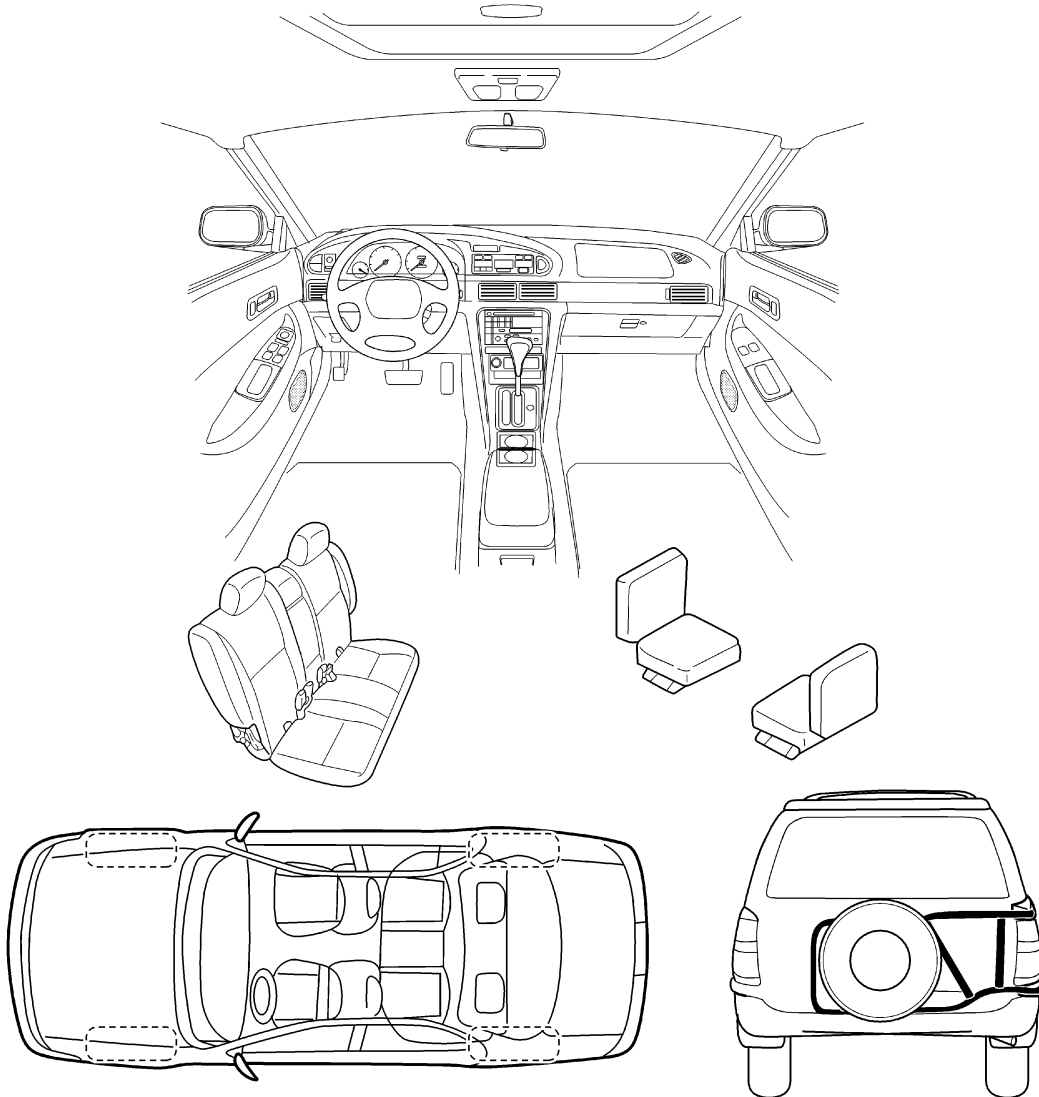

Continue to the back of the worksheet and briefly describe the location of the noise or rattle. In addition, please indicate the conditions which are present when the noise occurs.

LIWA0276E



# SQUEAK AND RATTLE TROUBLE DIAGNOSES

## SQUEAK & RATTLE DIAGNOSTIC WORKSHEET- page 2

Briefly describe the location where the noise occurs:

---

---

---

### II. WHEN DOES IT OCCUR? (check the boxes that apply)

- |  |   |
|--|---|
| <input type="checkbox"/> anytime                             | <input type="checkbox"/> after sitting out in the sun |
| <input type="checkbox"/> 1 <sup>st</sup> time in the morning | <input type="checkbox"/> when it is raining or wet    |
| <input type="checkbox"/> only when it is cold outside        | <input type="checkbox"/> dry or dusty conditions      |
| <input type="checkbox"/> only when it is hot outside         | <input type="checkbox"/> other: _____                 |

### III. WHEN DRIVING:

- through driveways
- over rough roads
- over speed bumps
- only at about \_\_\_\_ mph
- on acceleration
- coming to a stop
- on turns : left, right or either (circle)
- with passengers or cargo
- other: \_\_\_\_\_
- after driving \_\_\_\_ miles or \_\_\_\_ minutes

### IV. WHAT TYPE OF NOISE?

- squeak (like tennis shoes on a clean floor)
- creak (like walking on an old wooden floor)
- rattle (like shaking a baby rattle)
- knock (like a knock on a door)
- tick (like a clock second hand)
- thump (heavy, muffled knock noise)
- buzz (like a bumble bee)

### TO BE COMPLETED BY DEALERSHIP PERSONNEL

#### Test Drive Notes:

---

---

	<u>YES</u>	<u>NO</u>	Initials of person <u>performing</u>
Vehicle test driven with customer	<input type="checkbox"/>	<input type="checkbox"/>	_____
- Noise verified on test drive	<input type="checkbox"/>	<input type="checkbox"/>	_____
- Noise source located and repaired	<input type="checkbox"/>	<input type="checkbox"/>	_____
- Follow up test drive performed to confirm repair	<input type="checkbox"/>	<input type="checkbox"/>	_____

VIN: \_\_\_\_\_ Customer Name: \_\_\_\_\_

W.O. #: \_\_\_\_\_ Date: \_\_\_\_\_

**This form must be attached to Work Order**

SBT844

# CLIP AND FASTENER









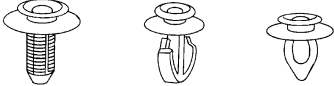

## CLIP AND FASTENER

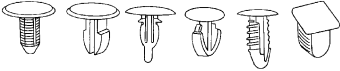
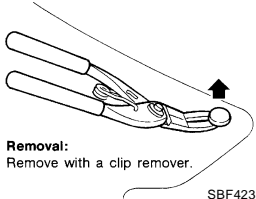
PFP:76906

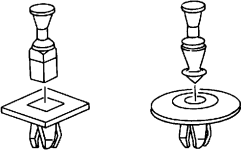
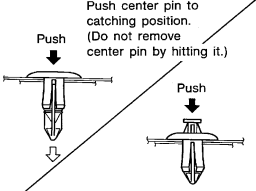

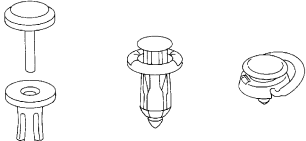
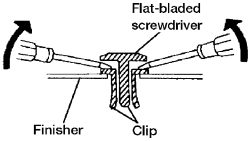

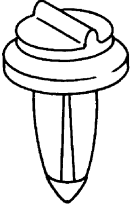
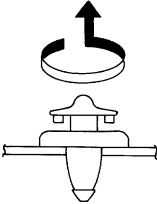

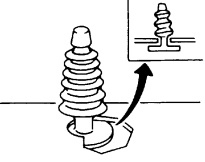
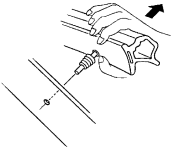
### Description

EIS0016W

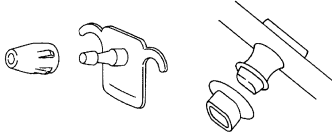
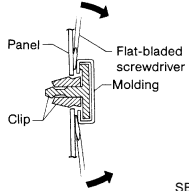
- Clips and fasteners in EI section correspond to the following numbers and symbols.
- Replace any clips and/or fasteners which are damaged during removal or installation.

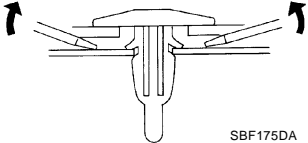
Symbol No.	Shapes	Removal & Installation
<p>C101</p> 	 <p style="text-align: center;">SBF302H</p>	<p><b>Removal:</b> Remove by bending up with flat-bladed screwdrivers or clip remover.</p>  <p style="text-align: right;">SBF367BA</p>
<p>C103</p> 	 <p style="text-align: center;">SBT095</p>	 <p><b>Removal:</b> Remove with a clip remover.</p> <p style="text-align: right;">SBF423H</p>
<p>C203</p> 	 <p style="text-align: center;">SBF258G</p>	<p>Push center pin to catching position. (Do not remove center pin by hitting it.)</p>  <p><b>Installation:</b> SBF708E</p>
<p>C205</p> 	 <p style="text-align: center;">MBT080A</p>	<p><b>Removal:</b></p>  <p style="text-align: right;">SBF638CA</p>
<p>C206</p> 	 <p style="text-align: center;">MBF519B</p>	 <p style="text-align: right;">MBF520B</p>
<p>CE103</p> 	 <p style="text-align: center;">SBF104B</p>	<p><b>Removal:</b></p>  <p style="text-align: right;">SBF147B</p>

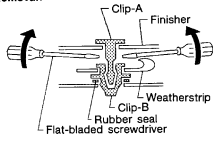
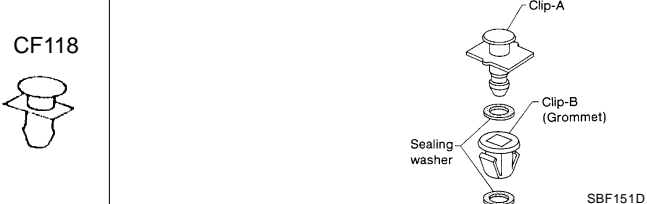
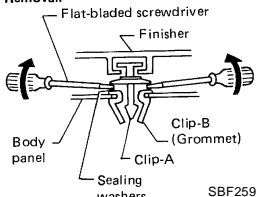
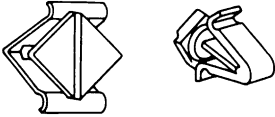
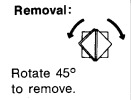

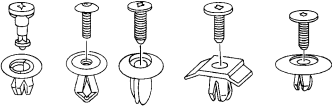
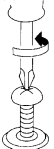
# CLIP AND FASTENER

Symbol No.	Shapes	Removal & Installation
CE107	 <p style="text-align: center;">SBF411H</p>	 <p style="text-align: right;">SBF767B</p>
CE117	 <p style="text-align: center;">SBF174D</p>	<p><b>Removal:</b> Remove by bending up with a flat-bladed screwdriver or pliers.</p>  <p style="text-align: right;">SBF175DA</p>
CF110	 <p style="text-align: center;">SBF648B</p>	<p><b>Removal:</b></p>  <p style="text-align: right;">SBF649B</p>
CF118	 <p style="text-align: center;">SBF151D</p>	<p><b>Removal:</b></p>  <p style="text-align: right;">SBF259G</p>
CG101	 <p style="text-align: center;">SBF145B</p>	<p><b>Removal:</b></p>  <p>Rotate 45° to remove.</p> <p><b>Installation:</b></p>  <p><b>Removal:</b></p>  <p style="text-align: right;">SBF085B</p>
CS101	 <p style="text-align: center;">SBF078B</p>	<p><b>Removal:</b></p> <ol style="list-style-type: none"> <li>Screw out with a Phillips screwdriver.</li> <li>Remove female portion with flat-bladed screwdriver.</li> </ol>  <p style="text-align: right;">SBF992G</p>

A  
B  
C  
D  
E  
F  
G  
H  
I  
J  
K  
L  
M

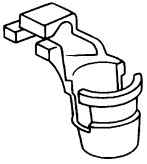
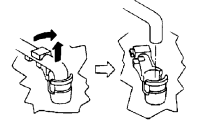

# CLIP AND FASTENER

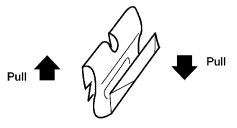
Symbol No.	Shapes	Removal & Installation
CR103	 <p style="text-align: center;">SBF768B</p>	<p><b>Removal:</b> Holder portion of clip must be spread out to remove rod.</p>  <p style="text-align: right;">SBF770B</p>
Metal Clip	 <p style="text-align: center;">WBT072</p>	<p><b>Removal:</b></p>  <p style="text-align: right;">WBT073</p>

# BODY FRONT END

## BODY FRONT END

PFPH5022

### Removal and Installation

EIS0016X

- When removing or installing hood, place a cloth or other padding on front fender panels and cowl top. This prevents vehicle body from being scratched.
- Bumper fascia is made of plastic. Do not use excessive force and be sure to keep oil away from it.
- Hood adjustment: Adjust at hinge portion. **B**
- Hood lock adjustment: After adjusting, check hood lock control operation. Apply a coat of grease to hood lock engaging mechanism.
- Hood opener: Do not attempt to bend cable forcibly. Doing so increases effort required to unlock hood.

### FRONT BUMPER ASSEMBLY

1. Remove screws securing left and right front fog lamps, and remove the lamps (if equipped); or remove filler trim panel.
2. Remove four clips C205 from the top of the front grille, pull up to unclip bottom and remove. **A**
3. Remove clips C205 and screws located on front side of fender protector at wheel opening.
4. Remove three bolts from the air deflector.
5. Remove two bolts securing lower side of front bumper fascia.
6. Pull off front bumper fascia and energy absorber.
7. Remove four nuts securing bumper reinforcement, then remove bumper reinforcement.
8. Remove four bolts securing front bumper side stays.
9. Remove front bumper side stays.
10. Remove the air dam if necessary.

A  
B  
C  
D  
E  
F  
G  
H  
I  
J  
K  
L  
M

EI

# BODY FRONT END

## QG18DE

### SEC. 620 • 623 • 630

#### Hood lock adjustment

Adjust hood so that hood primary lock meshes at a position 1 to 1.5mm (0.039 to 0.059 in) lower than fender.

After hood lock adjustment, adjust bumper rubber.

When securing hood lock, ensure that it does not tilt. Striker must be positioned at the center of hood primary lock.

After adjustment, ensure that hood primary and secondary lock operate properly.

Hood lock secondary latch hooking length.

More than 5.0 mm (0.197 in)

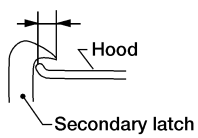

#### Bumper rubber adjustment

Adjust so that hood is aligned with fender, At that time deflection is approximately 2 mm (0.08 in).

[Bumper rubber free height is approximately 13 mm (0.51 in)]

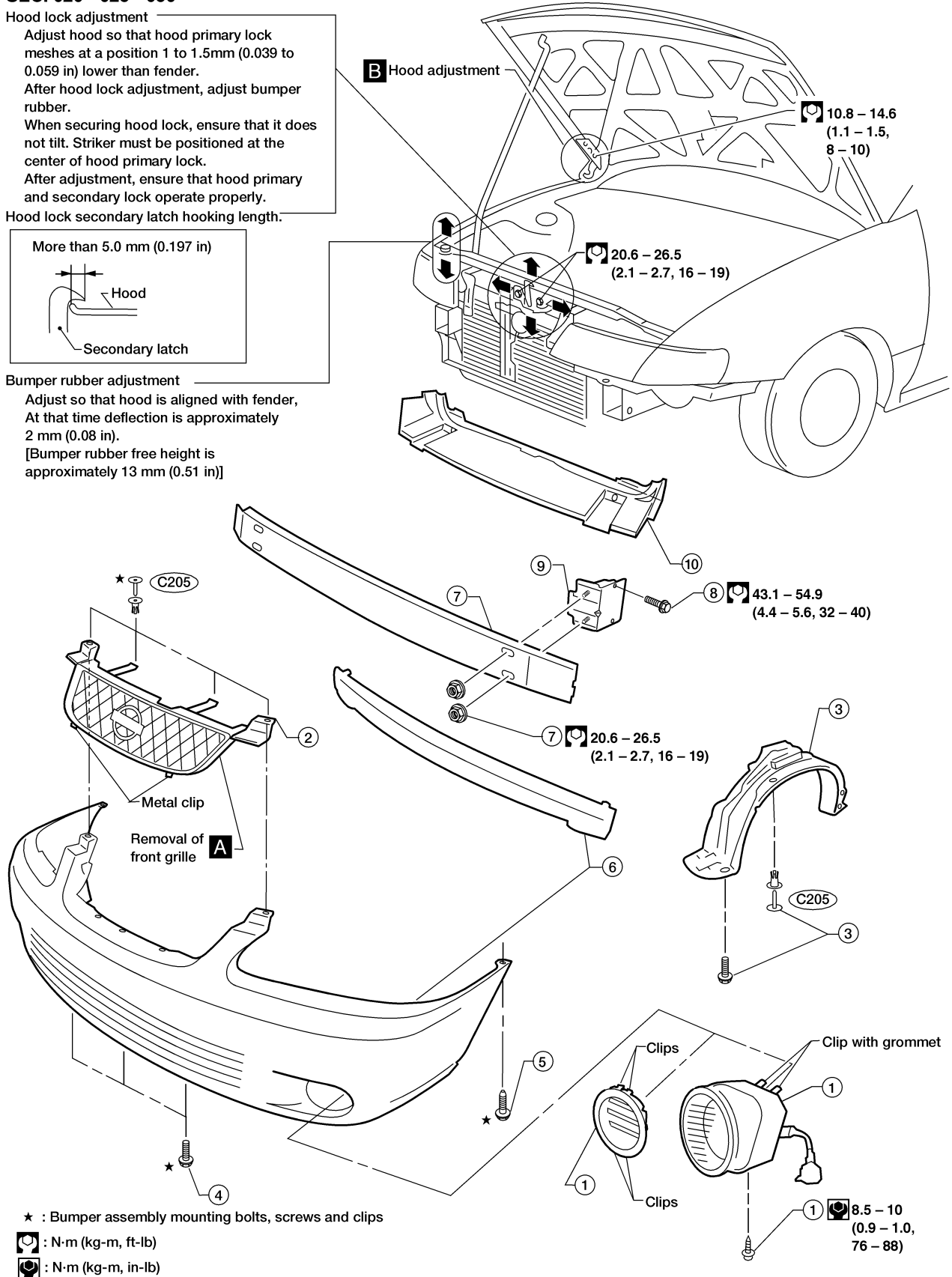

\* : Bumper assembly mounting bolts, screws and clips

: N·m (kg·m, ft·lb)

: N·m (kg·m, in·lb)

WBT038

# BODY FRONT END

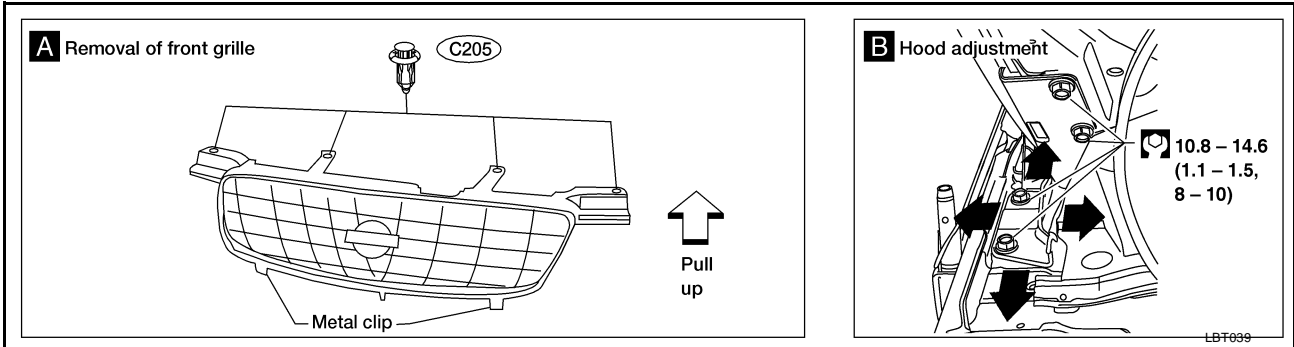

A

B

C

D

E

F

G

H

EI

J

K

L

M

# BODY FRONT END

## QR25DE

### SEC. 620 • 623 • 630

#### Hood lock adjustment

Adjust hood so that hood primary lock meshes at a position 1 to 1.5 mm (0.039 to 0.059 in) lower than fender.

After hood lock adjustment, adjust bumper rubber.

When securing hood lock, ensure that it does not tilt. Striker must be positioned at the center of hood primary lock.

After adjustment, ensure that hood primary and secondary lock operate properly.

#### Hood lock secondary latch hooking length.

More than 5.0 mm (0.197 in)

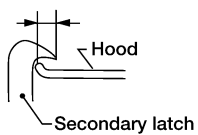

#### Bumper rubber adjustment

Adjust so that hood is aligned with fender, At that time deflection is approximately 2 mm (0.08 in).

[Bumper rubber free height is approximately 13 mm (0.51 in)]

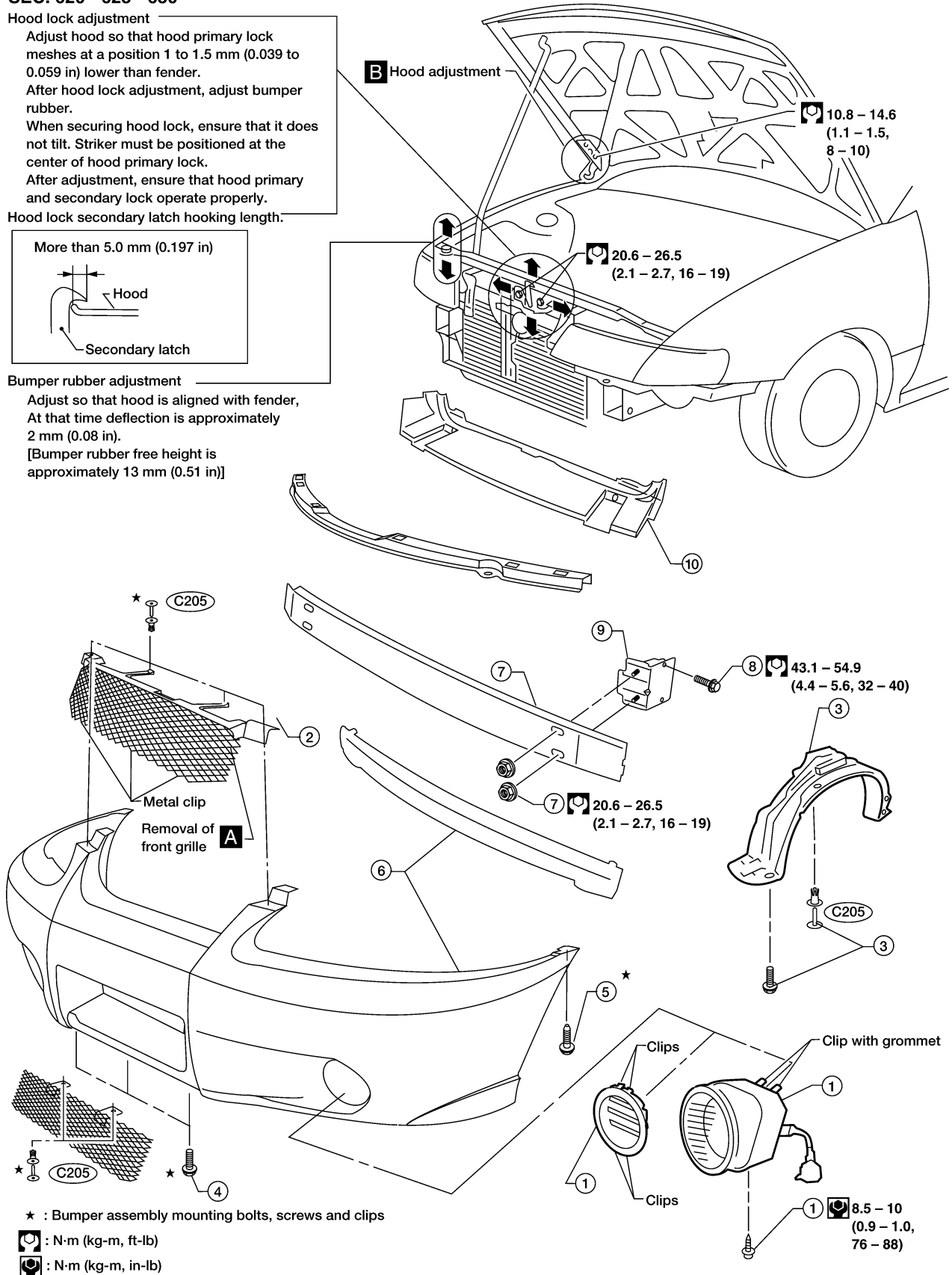

LIA0119E



# BODY FRONT END

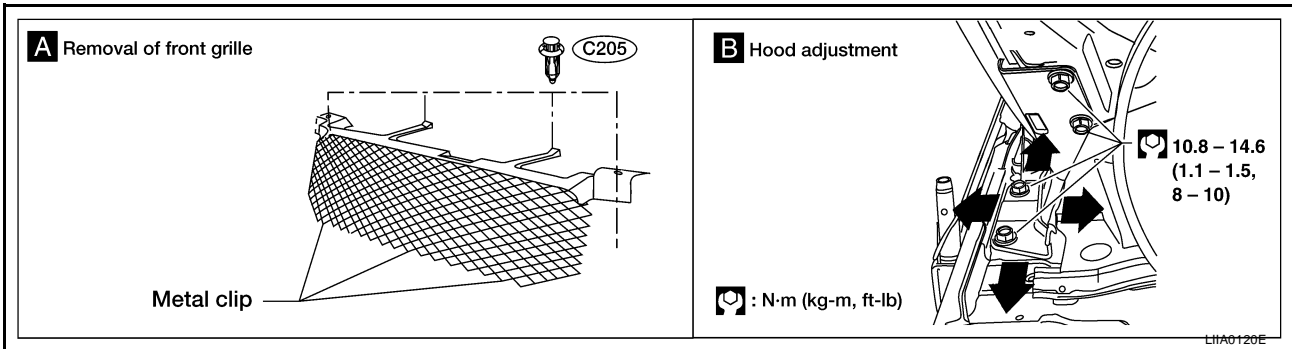

A

B

C

D

E

F

G

H

EI

J

K

L

M

# BODY REAR END AND OPENER

---

## BODY REAR END AND OPENER

PF2:F2022

### Removal and Installation

EIS0016Y

- When removing or installing trunk lid, place a cloth or other padding on rear fender panels. This prevents vehicle body from being scratched.
- Bumper fascia is made of plastic. Do not use excessive force and be sure to keep oil away from it.
- Trunk lid adjustment: Adjust at hinge-trunk lid portion for proper trunk lid fit.
- Trunk lid lock system adjustment: Adjust striker so that it is in the center of the lock. After adjustment, check trunk lid lock operation.
- Opener cable: Do not attempt to bend cable using excessive force.
- After installation, make sure that trunk lid and fuel filler lid open smoothly.

### REAR BUMPER ASSEMBLY

1. Remove two clips C205 from lower side and four clips C205 from upper side of rear bumper fascia.
2. Remove two screws from each quarter panel side.
3. Remove two screws from each upper side of fascia into bumper side brackets.
4. Remove rear bumper fascia.
5. Remove energy absorber from rear bumper reinforcement.
6. Remove four nuts securing bumper reinforcement and remove bumper reinforcement.
7. Remove four bolts securing each bumper side stay, and remove bumper side stays.

# BODY REAR END AND OPENER

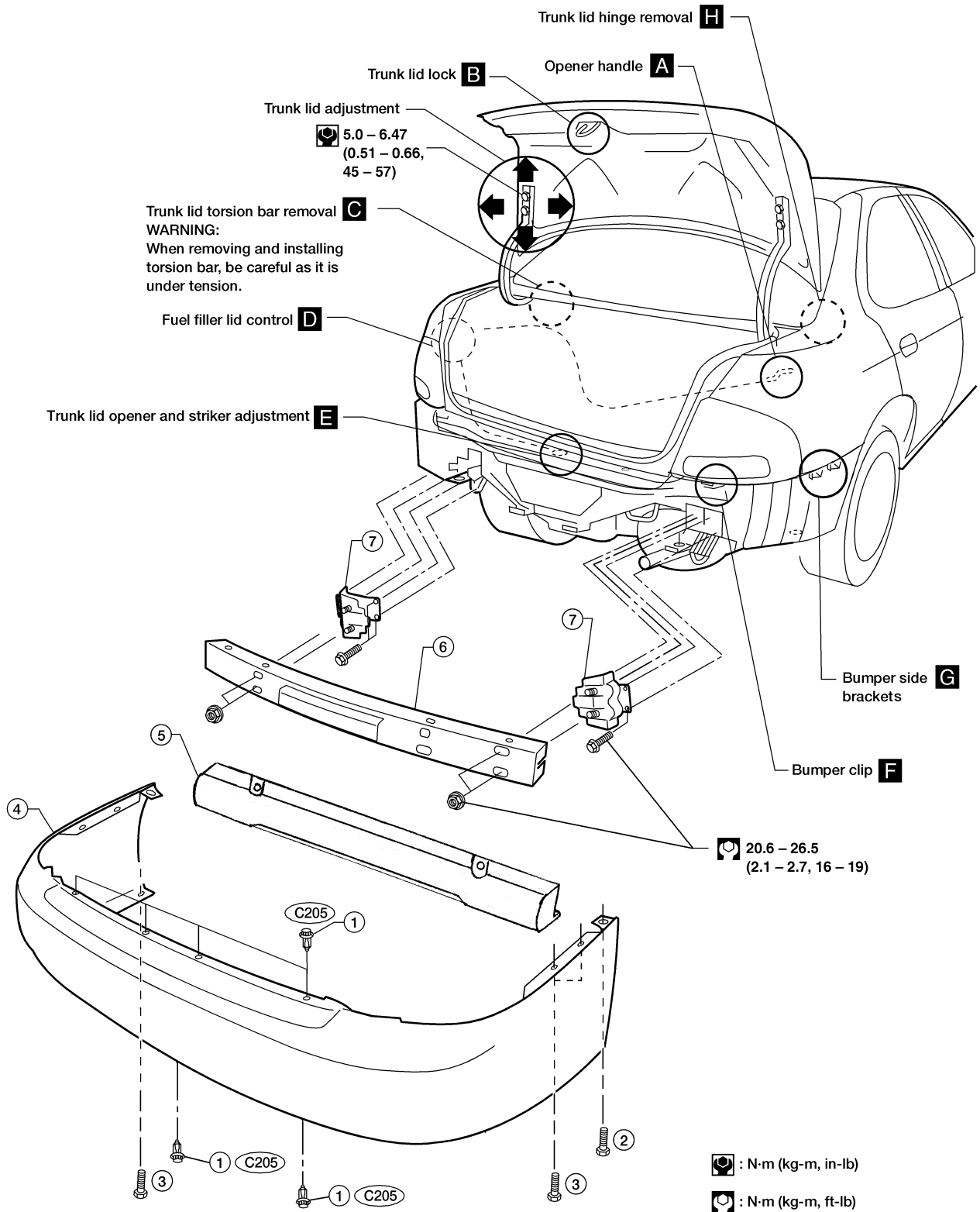

A  
B  
C  
D  
E  
F  
G  
H  
EI  
J  
K  
L  
M

# BODY REAR END AND OPENER

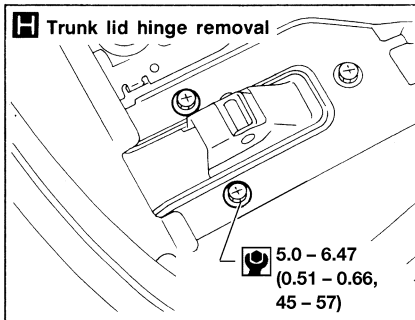
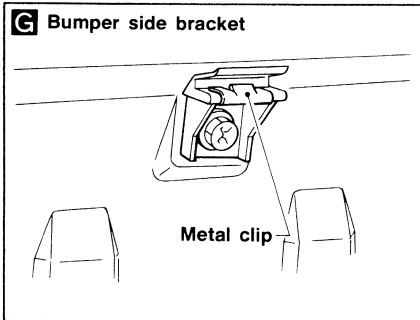
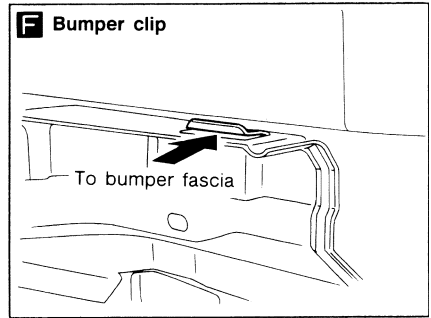
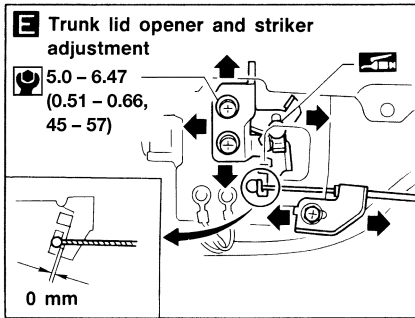
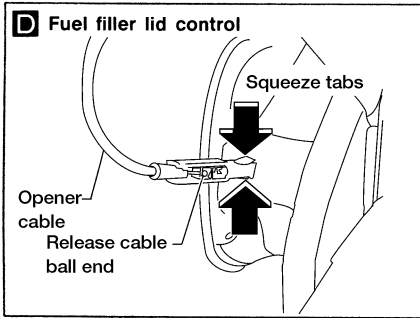
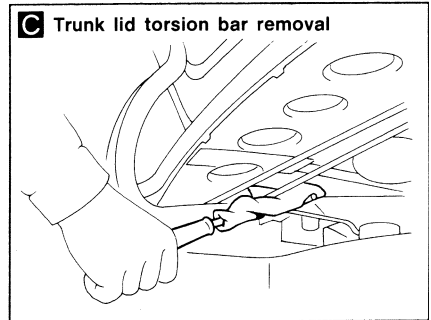
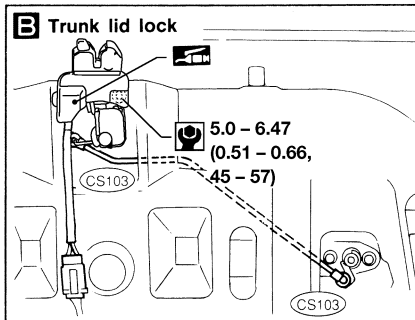
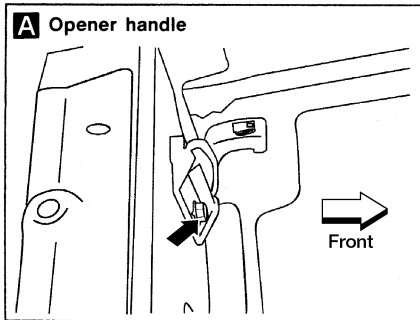

: N·m (kg-m, in-lb)

WBT086

# WINDSHIELD MOLDING

## WINDSHIELD MOLDING

### Windshield and Rear Window

PFP:72700

EIS0016Z

Windshield side molding

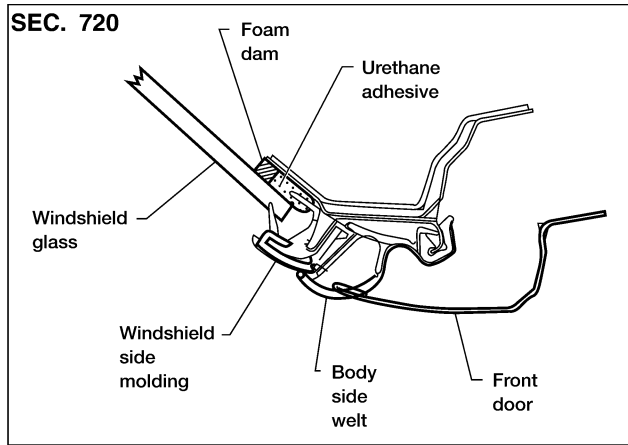

Windshield upper molding

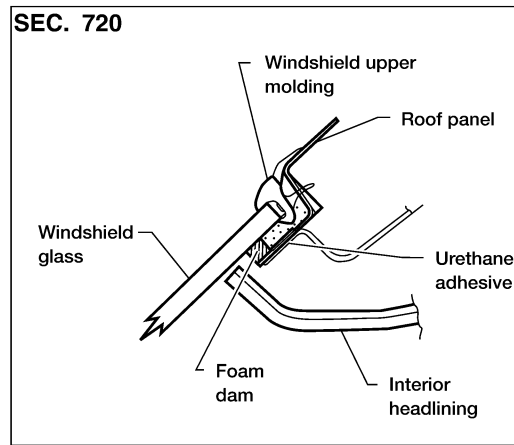

Rear window molding

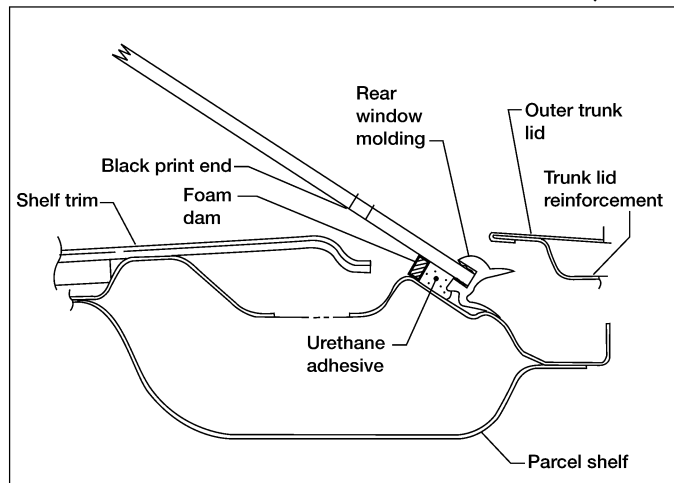
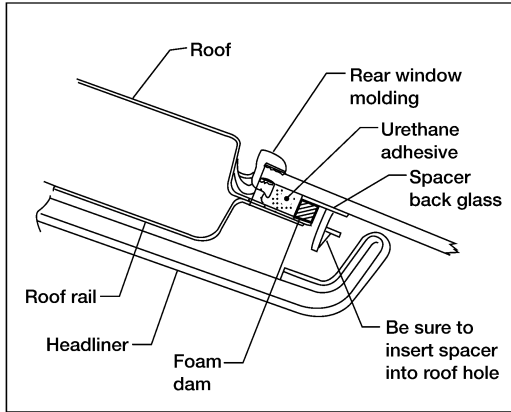

WBT114

A  
B  
C  
D  
E  
F  
G  
H  
EI  
J  
K  
L  
M

# EXTERIOR

## EXTERIOR

PFP:AAAAA

### Removal and Installation

EIS00170

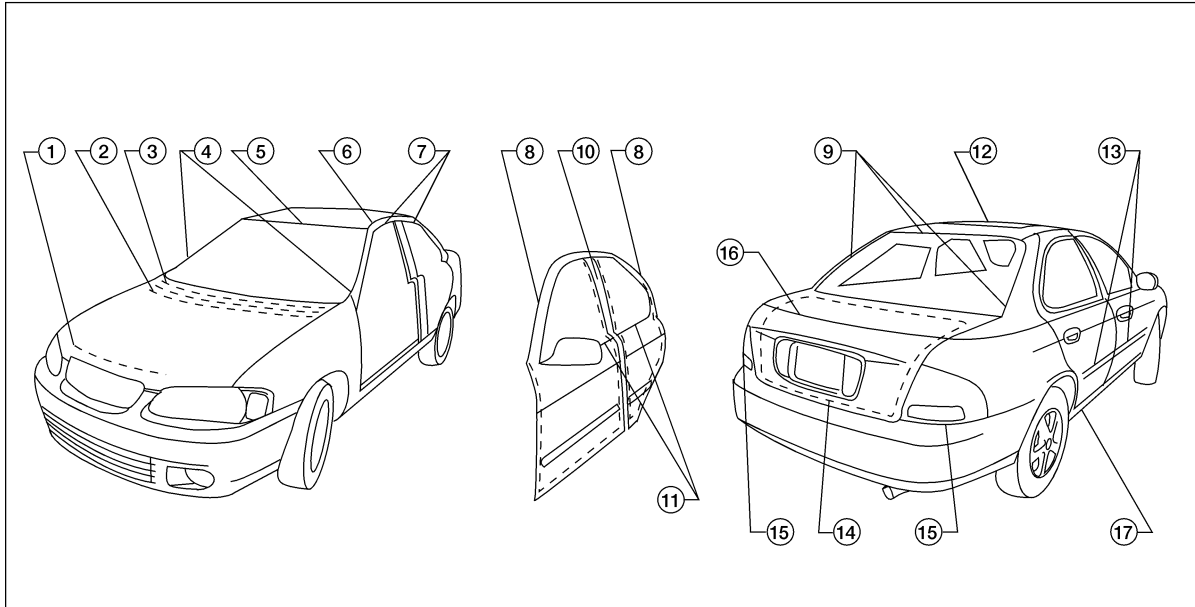

#### ① Hood front seal

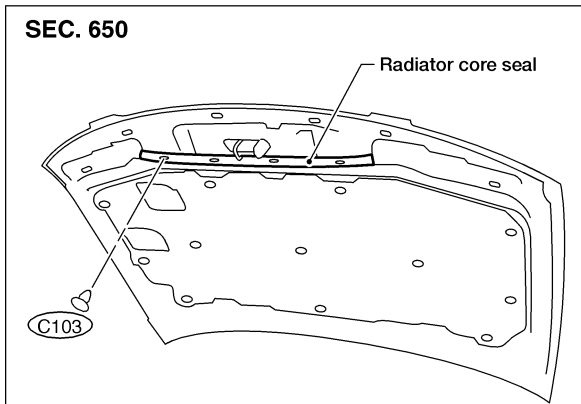

#### ② ③ Cowl top seal and cowl top grille

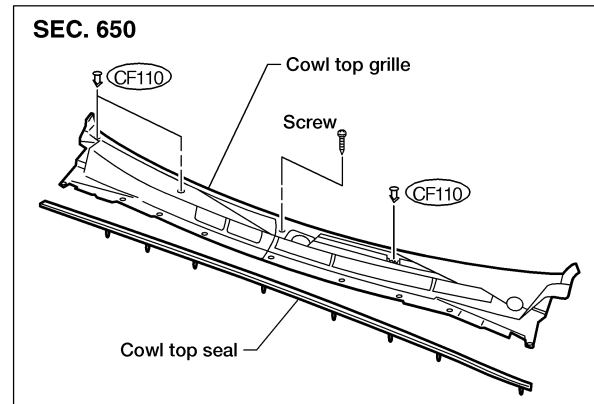

WBT054

# EXTERIOR

## ④ Windshield side molding

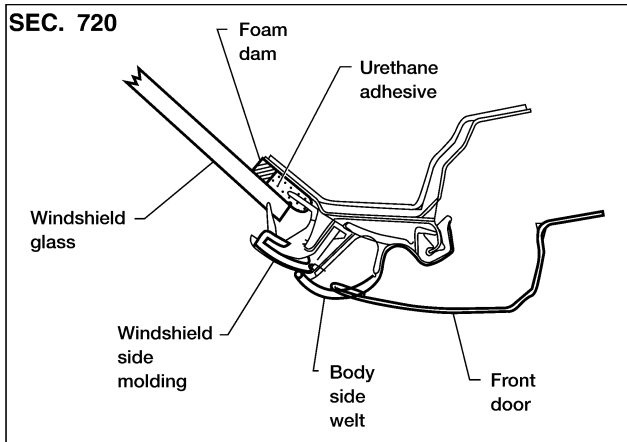

## ⑤ Windshield upper molding

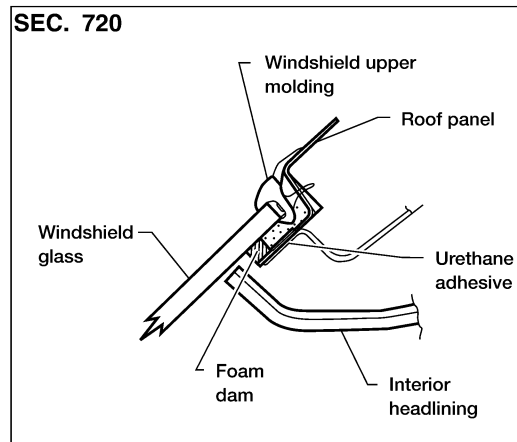

## ⑨ Rear window molding

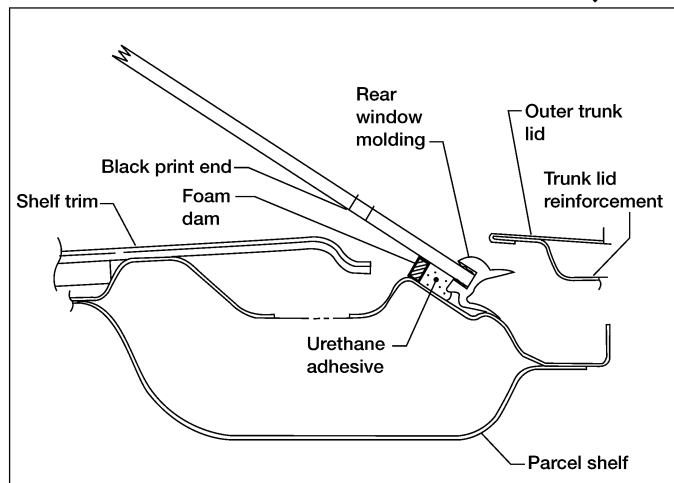
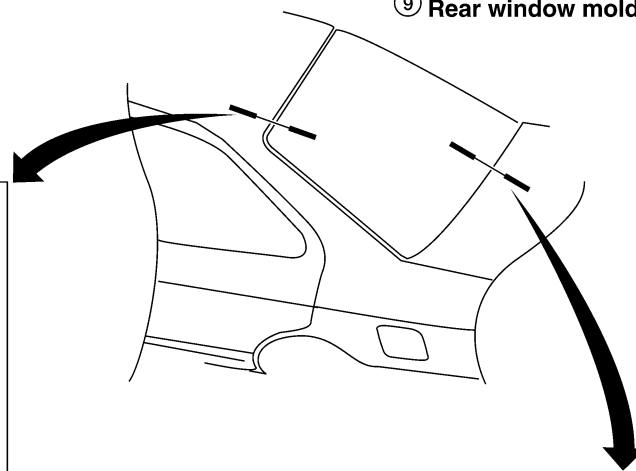
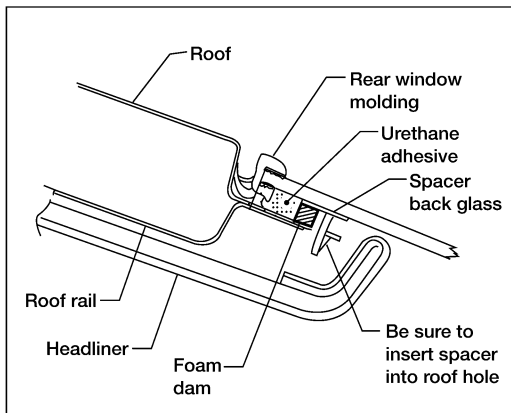

WBT113

A  
B  
C  
D  
E  
F  
G  
H  
EI  
J  
K  
L  
M

# EXTERIOR

## ⑥ Drip weatherstrip

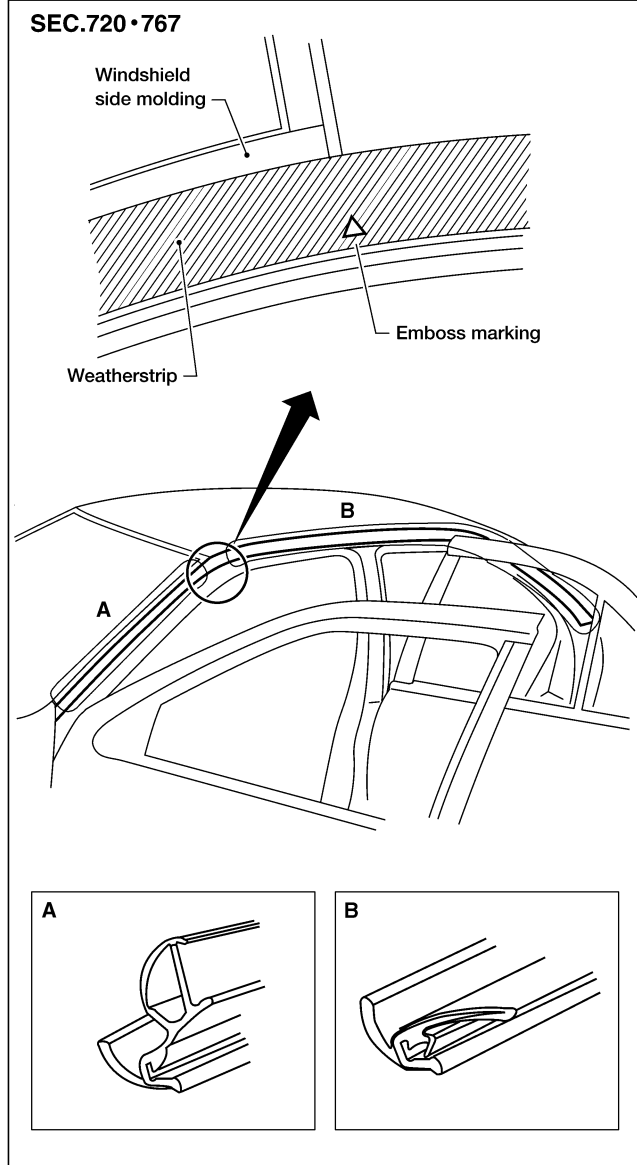

## ⑦ Body side welt

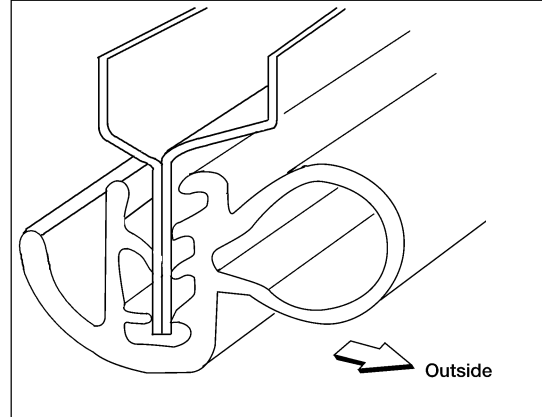

## ⑧ Door weatherstrip

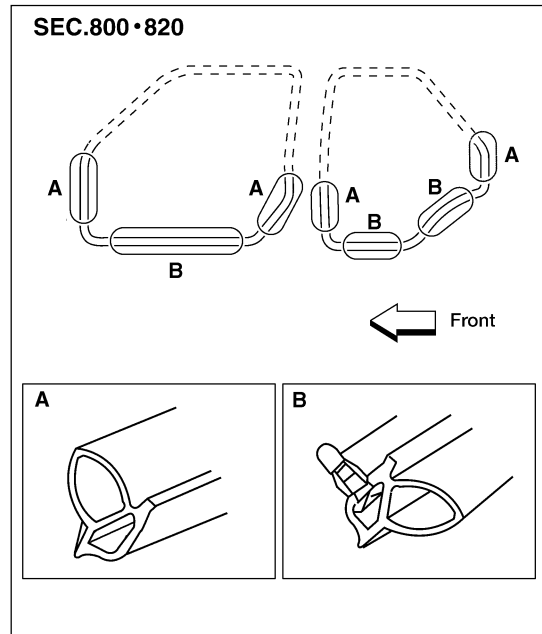

LIA0009E



# EXTERIOR

## ⑩ Rear door parting seal

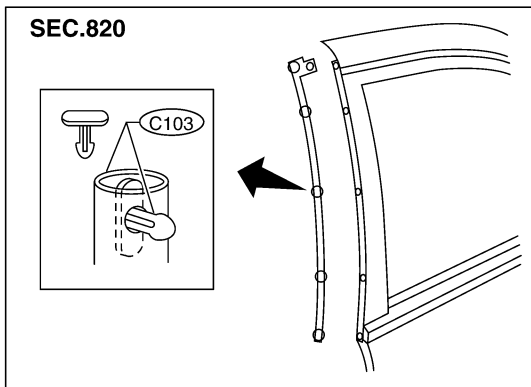

## ⑪ Door outside molding

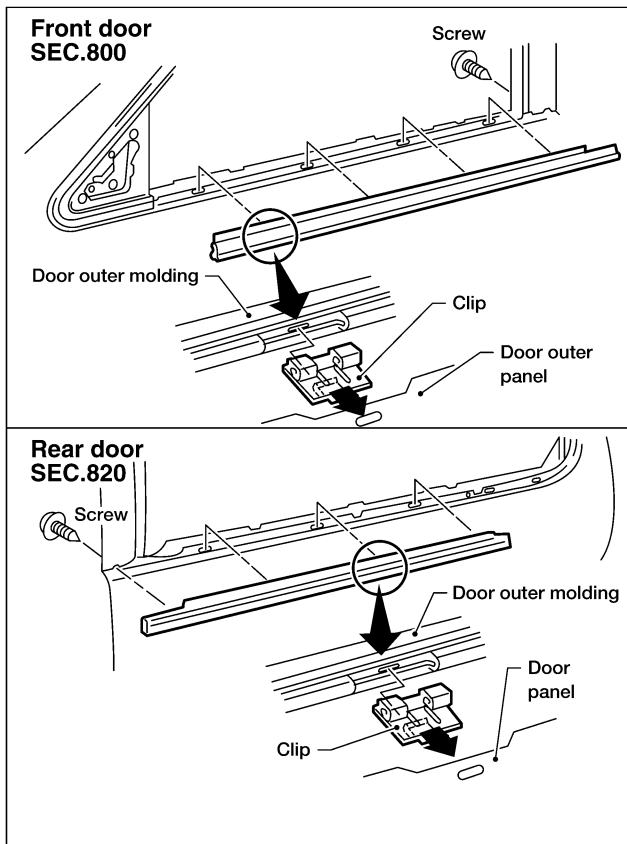

## ⑫ Sunroof lid weatherstrip

Sunroof weatherstrip is part of the glass lid and must be replaced as an assembly.

## ⑬ Side guard molding

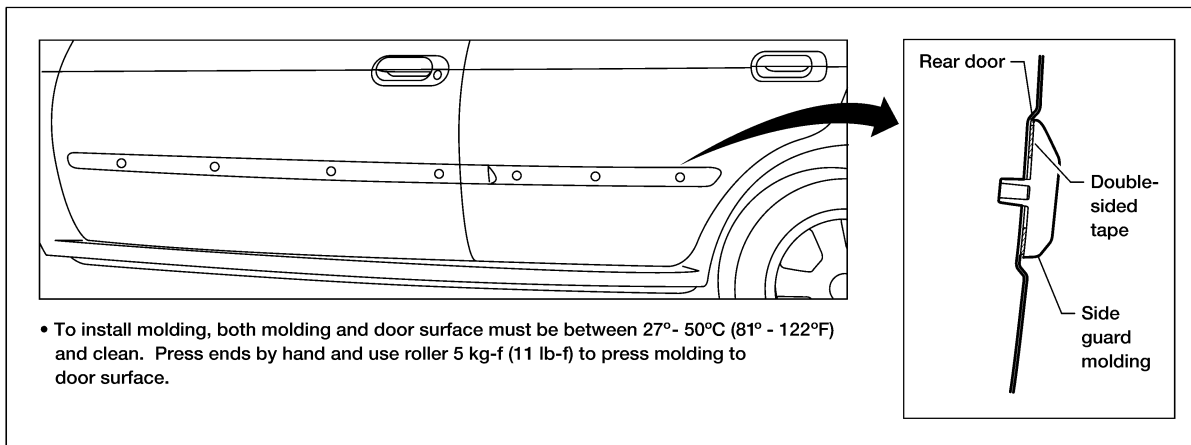

LIA0148E

A  
B  
C  
D  
E  
F  
G  
H  
EI  
J  
K  
L  
M

# EXTERIOR

## ⑭ Trunk lid weatherstrip

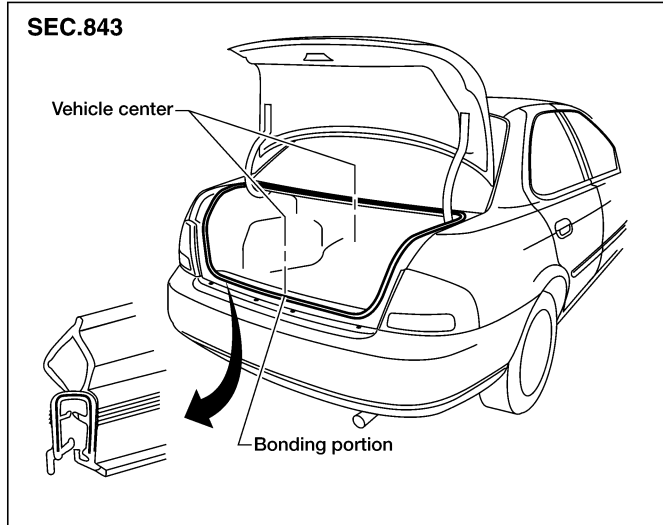

## ⑮ Rear combination lamp

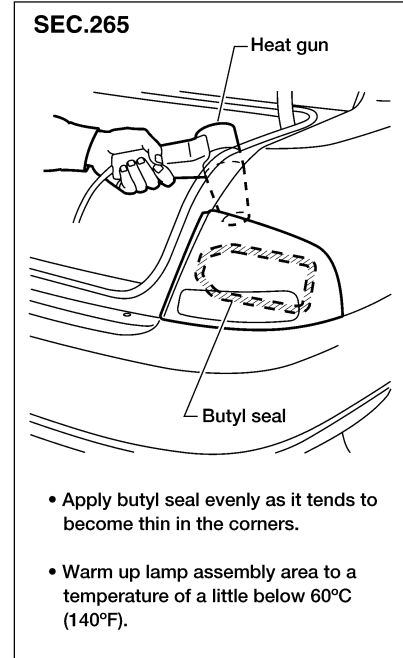

LIA0010E

# EXTERIOR

## SEC. 960

- ⑩ Rear air spoiler and high-mounted stop lamp
  - When installing, make sure that there are no gaps or waves at ends of air spoiler.
  - Before installing spoiler, clean and remove oil from surface where spoiler will be mounted.

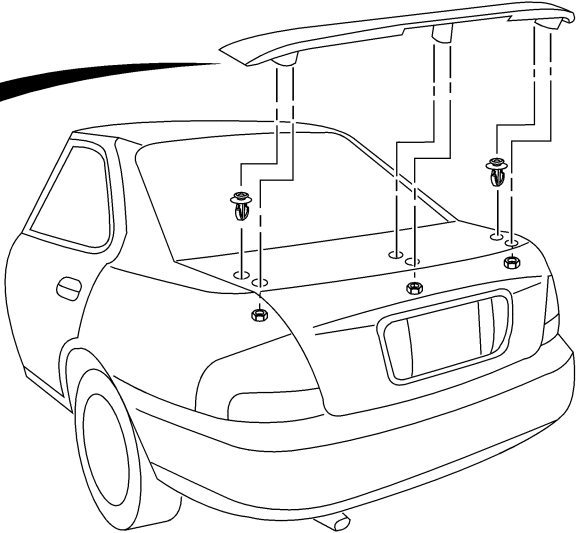
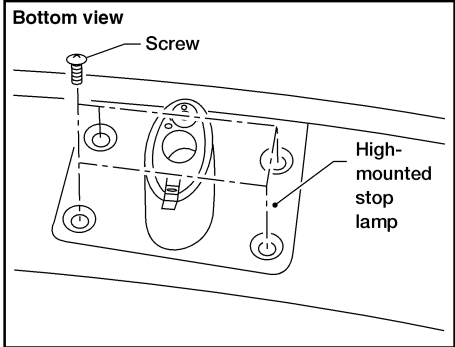

LBT065

## ⑩ Fender and center mudguard

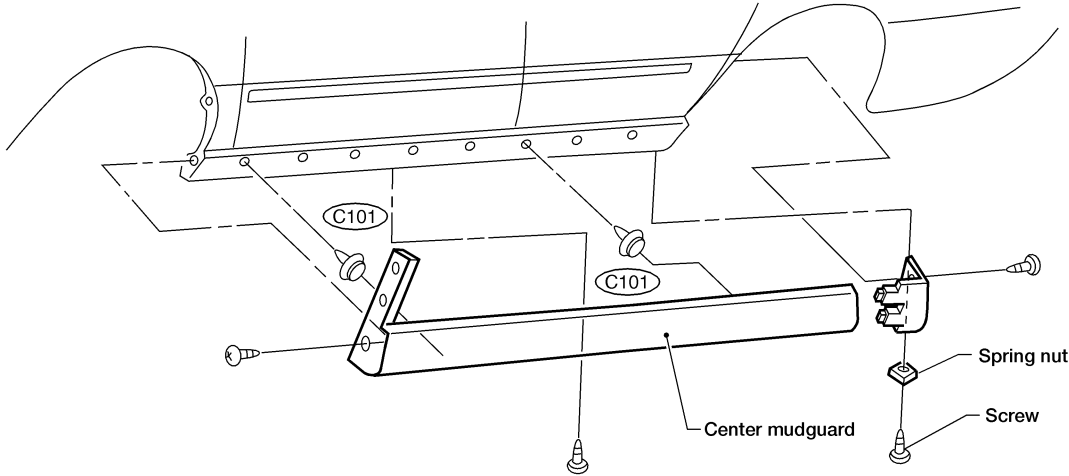

LBT059

A

B

C

D

E

F

G

H

EI

J

K

L

M

## SIDE AND FLOOR TRIM

### Removal and Installation

**CAUTION:**

- **Wrap the tip of flat-bladed screwdriver with a cloth when removing metal clips from garnishes.**
1. Remove A/T finisher or M/T shift lever boot. Refer to [IP-10, "Removal and Installation"](#) .
  2. Remove the console. Refer to [IP-10, "Removal and Installation"](#) .
  3. Remove front and rear seats. Refer to [SE-3, "Removal and Installation"](#) (front), or [SE-5, "Removal and Installation"](#) (rear).
  4. Remove kick plates.
  5. Remove dash side lower garnish. **A**
  6. Remove body side welts.
  7. Remove front seat belt floor anchor bolt. Refer to [SB-3, "Removal and Installation"](#) .
  8. Remove rear seat belt floor anchor bolt. Refer to [SB-5, "Removal and Installation"](#) .
  9. Remove center pillar lower garnish.
  10. Remove adjuster cover and pillar shoulder bolt. Refer to [SB-3, "Removal and Installation"](#) .
  11. Remove floor carpet.
  12. Remove center pillar upper garnish. **C**
  13. Remove front pillar garnish. **B**
  14. Remove rear pillar garnish. **D**
  15. Remove parcel shelf.
  16. Remove center rear seat back finisher.
  17. Remove side rear seat back finishers. **E**

# SIDE AND FLOOR TRIM

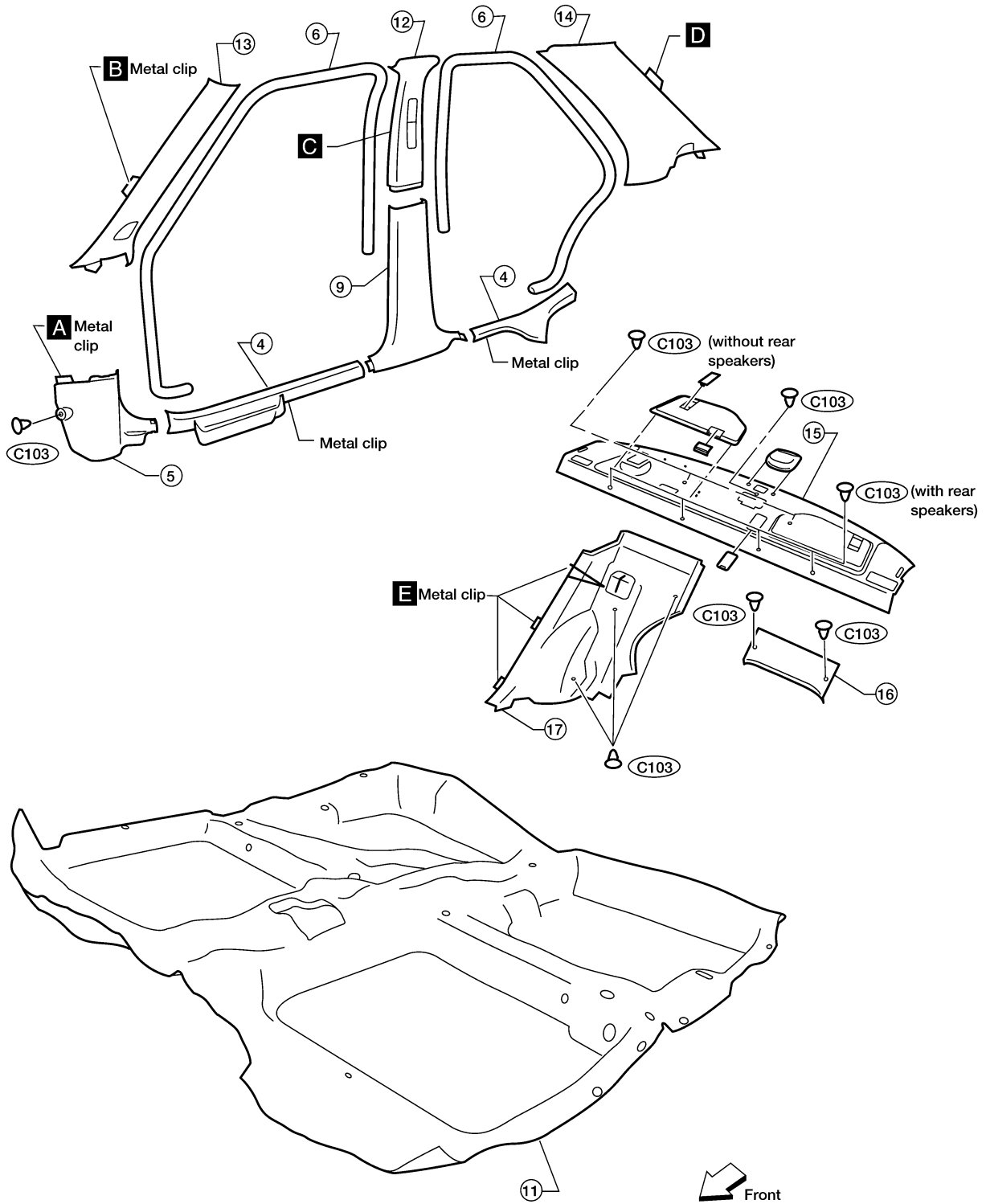

A  
B  
C  
D  
E  
F  
G  
H  
EI  
J  
K  
L  
M

# SIDE AND FLOOR TRIM

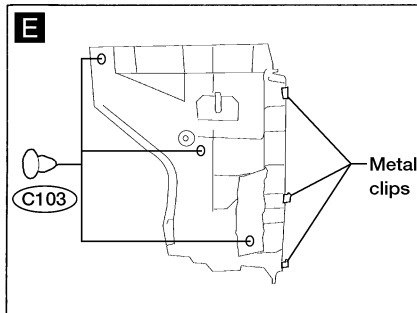
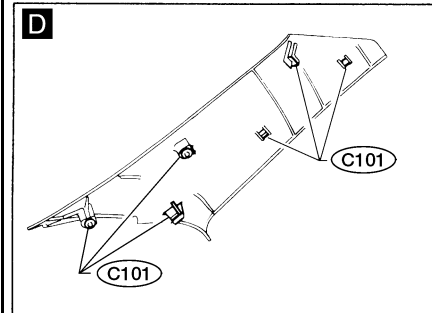
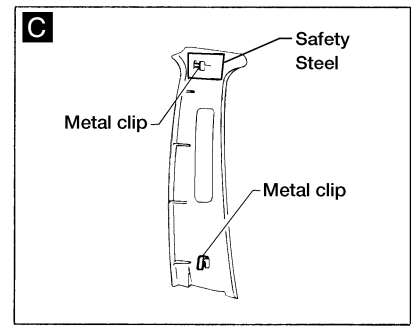
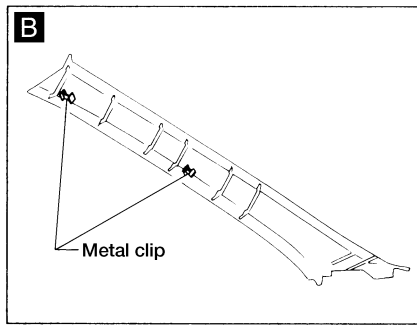
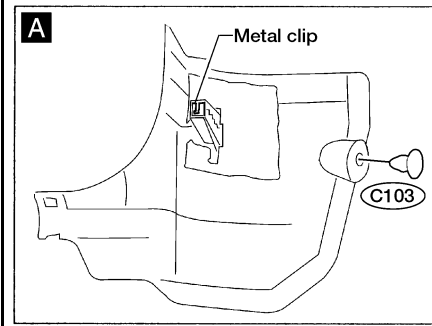

WBT044

# DOOR FINISHER

PFP:80900

## DOOR FINISHER

### Removal and Installation

EIS00172

#### CAUTION:

Wrap the tip of a flat-bladed screwdriver with cloth when prying pawls from door trim.

1. Remove the door pull finisher(s).
2. Remove power window switch(es) finisher(s), then disconnect the connector(s) (models equipped with power windows).
- **Do not lift the front of the power window switch assembly.**
3. Remove window regulator handle (models without power windows).
4. Remove screws and disconnect clips C101 and clips C103 from door.
5. Reach behind and carefully pull door trim panel from inside handle until finisher pops off.
6. Lift out door trim.

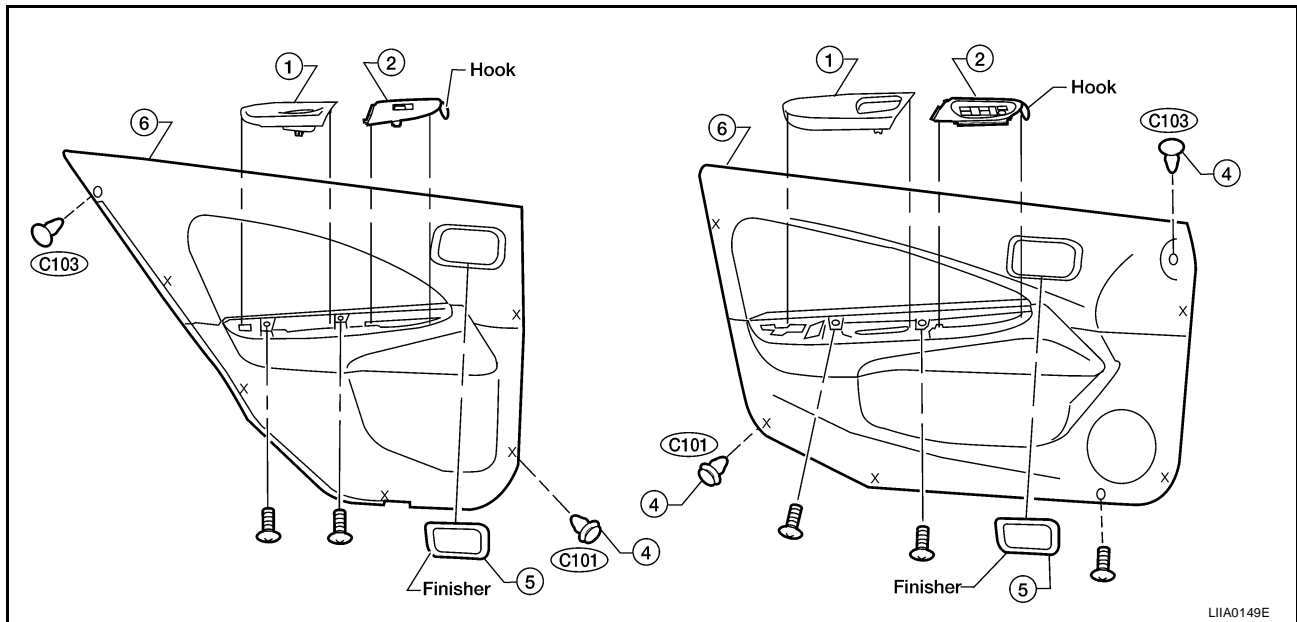

LIA0149E

A  
B  
C  
D  
E  
F  
G  
H  
EI  
J  
K  
L  
M

# ROOF TRIM

PF7:73910

## ROOF TRIM

EIS00173

### Removal and Installation

1. Fully tilt front right and left seat backs backward.
2. Remove front pillar garnish, front and rear kick plates. Refer to [EI-28, "Removal and Installation"](#).
3. Remove center pillar lower and upper garnish, and rear pillar garnish. Refer to [EI-28, "Removal and Installation"](#).
4. Remove sun visors.
5. Remove interior lamp.
6. Remove assist grips. **A**
7. Remove sunroof welt (if equipped) and door welts.
8. Remove sunroof switch (if equipped) and map lamp assembly.
9. Remove clips attached to roof.
10. Take out headlining from the front passenger door.

SEC. 738-963-964

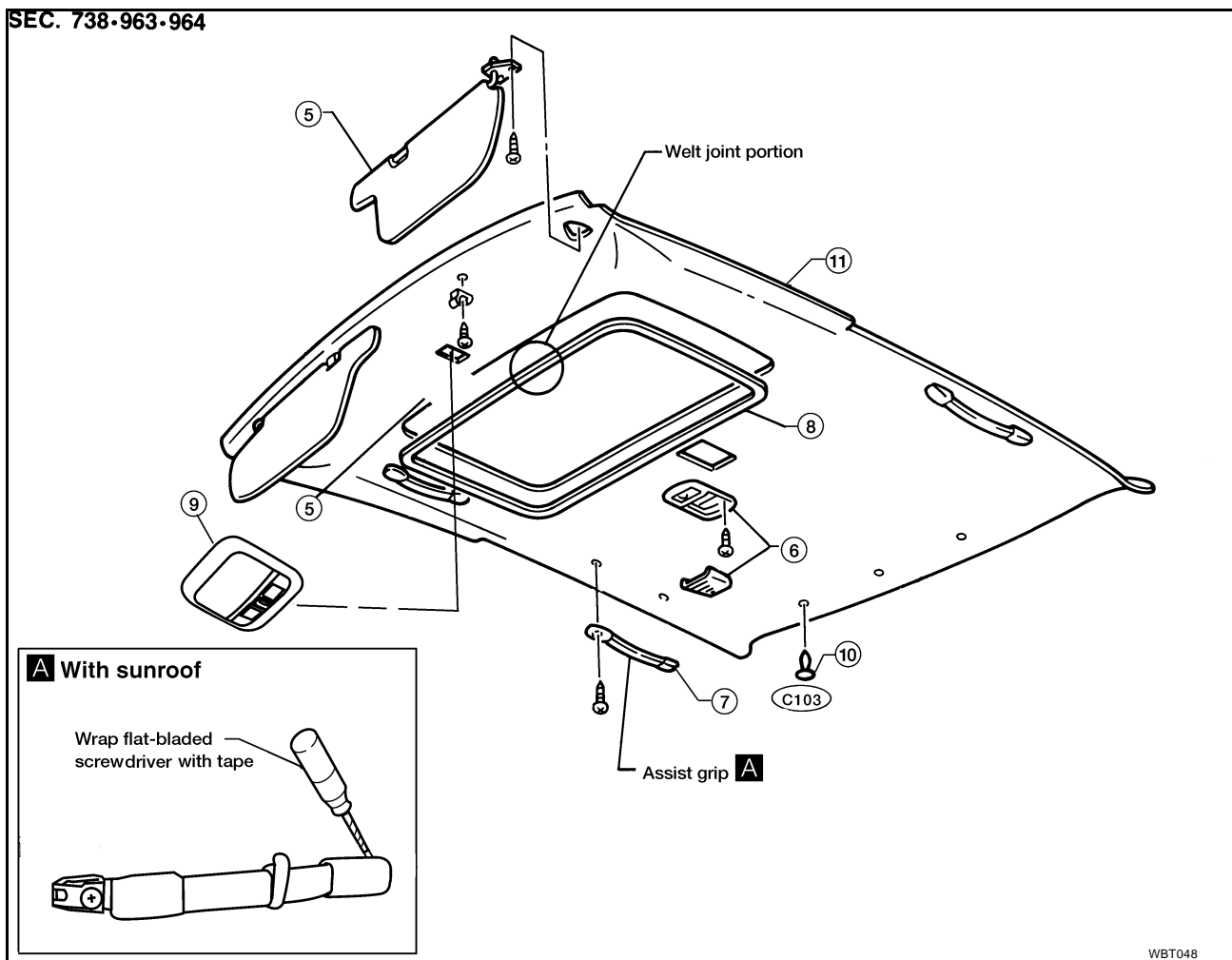



# TRUNK ROOM TRIM

## TRUNK ROOM TRIM

PFP:84920

### Removal and Installation

EIS00174

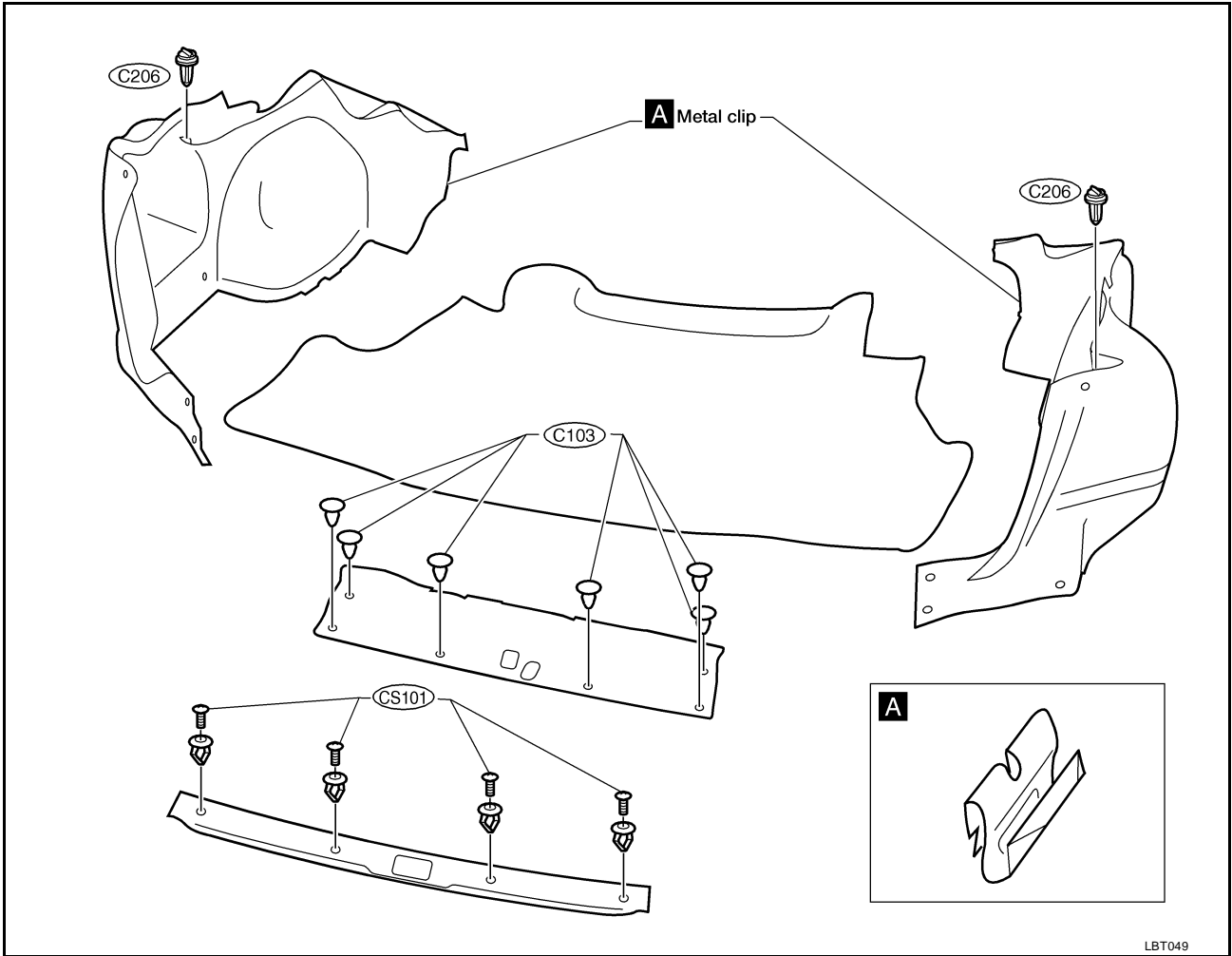

LBT049

A  
B  
C  
D  
E  
F  
G  
H  
EI  
J  
K  
L  
M

# TRUNK ROOM TRIM

---