

# SECTION **SRS**

## SUPPLEMENTAL RESTRAINT SYSTEM (SRS)

A  
B  
C

### CONTENTS

<p><b>PRECAUTIONS</b> ..... 3</p> <p>    Precautions for Supplemental Restraint System (SRS) “AIR BAG” and “SEAT BELT PRE-TENSIONER” ..... 3</p> <p>    Precautions for SRS “AIR BAG” and “SEAT BELT PRE-TENSIONER” Service ..... 3</p> <p>    Wiring Diagrams and Trouble Diagnosis ..... 3</p> <p><b>PREPARATION</b> ..... 4</p> <p>    Special service tool ..... 4</p> <p>    Commercial Service Tool ..... 4</p> <p><b>SRS CONFIGURATION</b> ..... 5</p> <p>    SRS Configuration ..... 5</p> <p>    Seat Belt Pre-tensioner with Load Limiter ..... 6</p> <p>    Side Air Bag ..... 6</p> <p>    Direct-connect SRS Component Connectors ..... 6</p> <p>    SRS Component Parts Location ..... 7</p> <p><b>TROUBLE DIAGNOSIS</b> ..... 8</p> <p>    Trouble Diagnoses Introduction ..... 8</p> <p>        DIAGNOSIS FUNCTION ..... 8</p> <p>        HOW TO CHANGE SELF-DIAGNOSIS MODE WITH CONSULT-II ..... 9</p> <p>        HOW TO CHANGE SELF-DIAGNOSIS MODE WITHOUT CONSULT-II ..... 9</p> <p>        HOW TO ERASE SELF-DIAGNOSIS RESULTS... 9</p> <p>    CONSULT-II Function (AIR BAG) ..... 11</p> <p>    How to Perform Trouble Diagnoses for Quick and Accurate Repair ..... 12</p> <p>        INFORMATION FROM CUSTOMER ..... 12</p> <p>        PRELIMINARY CHECK ..... 12</p> <p>        WORK FLOW ..... 13</p> <p>    Schematic ..... 14</p> <p>    Wiring Diagram — SRS — ..... 15</p> <p>    SRS Operation Check ..... 18</p> <p>        DIAGNOSTIC PROCEDURE 1 ..... 18</p> <p>    Trouble Diagnoses with CONSULT-II ..... 18</p> <p>        DIAGNOSTIC PROCEDURE 2 ..... 18</p> <p>        DIAGNOSTIC PROCEDURE 3 ..... 22</p> <p>        DIAGNOSTIC PROCEDURE 4 (CONTINUED FROM DIAGNOSTIC PROCEDURE 2) ..... 24</p> <p>        DIAGNOSTIC PROCEDURE 5 ..... 25</p>	<p>    Trouble Diagnoses without CONSULT-II ..... 29</p> <p>        DIAGNOSTIC PROCEDURE 6 ..... 29</p> <p>        DIAGNOSTIC PROCEDURE 7 ..... 34</p> <p>        DIAGNOSTIC PROCEDURE 8 (CONTINUED FROM DIAGNOSTIC PROCEDURE 6) ..... 35</p> <p>    Trouble Diagnoses: “AIR BAG” Warning Lamp Does Not Turn Off ..... 36</p> <p>        DIAGNOSTIC PROCEDURE 9 ..... 36</p> <p>    Trouble Diagnoses: “AIR BAG” Warning Lamp Does Not Turn On ..... 37</p> <p>        DIAGNOSTIC PROCEDURE 10 ..... 37</p> <p><b>DIAGNOSIS SENSOR UNIT</b> ..... 38</p> <p>    Removal and Installation ..... 38</p> <p>        REMOVAL ..... 38</p> <p>        INSTALLATION ..... 38</p> <p><b>FRONT SEAT BELT PRE-TENSIONER</b> ..... 39</p> <p>    Removal and Installation ..... 39</p> <p><b>SIDE AIR BAG (SATELLITE) SENSOR</b> ..... 40</p> <p>    Removal and Installation ..... 40</p> <p>        REMOVAL ..... 40</p> <p>        INSTALLATION ..... 40</p> <p><b>DRIVER AIR BAG MODULE</b> ..... 41</p> <p>    Removal and Installation ..... 41</p> <p>    Removal ..... 41</p> <p>    Installation ..... 42</p> <p><b>SPIRAL CABLE</b> ..... 43</p> <p>    Removal and Installation ..... 43</p> <p>    Removal ..... 43</p> <p>    Installation ..... 44</p> <p><b>FRONT PASSENGER AIR BAG MODULE</b> ..... 45</p> <p>    Removal and Installation ..... 45</p> <p>        REMOVAL ..... 45</p> <p>        INSTALLATION ..... 46</p> <p><b>COLLISION DIAGNOSIS</b> ..... 47</p> <p>    For Frontal Collision ..... 47</p> <p>        SRS INSPECTION (FOR FRONTAL COLLISION) ..... 47</p> <p>    For Side and Rollover Collision ..... 48</p> <p>        WHEN SRS IS ACTIVATED IN THE SIDE OR</p>
--	--

D  
E

F  
G

SRS

I  
J

K  
L

M

---

ROLLOVER COLLISION ..... 48  
WHEN SRS IS NOT ACTIVATED IN THE SIDE

OR ROLLOVER COLLISION ..... 48  
SRS INSPECTION (FOR SIDE AND ROLLOVER  
COLLISION) ..... 49

# PRECAUTIONS

## PRECAUTIONS

PF:00001

### Precautions for Supplemental Restraint System (SRS) “AIR BAG” and “SEAT BELT PRE-TENSIONER”

EHS000PP

The Supplemental Restraint System such as “AIR BAG” and “SEAT BELT PRE-TENSIONER”, used along with a front seat belt, helps to reduce the risk or severity of injury to the driver and front passenger for certain types of collision. Information necessary to service the system safely is included in the SRS and SB section of this Service Manual.

#### **WARNING:**

- To avoid rendering the SRS inoperative, which could increase the risk of personal injury or death in the event of a collision which would result in air bag inflation, all maintenance must be performed by an authorized NISSAN/INFINITI dealer.
- Improper maintenance, including incorrect removal and installation of the SRS, can lead to personal injury caused by unintentional activation of the system. For removal of Spiral Cable and Air Bag Module, see the SRS section.
- Do not use electrical test equipment on any circuit related to the SRS unless instructed to in this Service Manual. SRS wiring harnesses can be identified by yellow and/or orange harnesses or harness connectors.

### Precautions for SRS “AIR BAG” and “SEAT BELT PRE-TENSIONER” Service

EHS000JE

- Do not use electrical test equipment to check SRS circuits unless instructed to in this Service Manual.
- Before servicing the SRS, turn ignition switch “OFF”, disconnect both battery cables and wait at least 3 minutes.  
For approximately 3 minutes after the cables are removed, it is still possible for the air bag and seat belt pre-tensioner to deploy. Therefore, do not work on any SRS connectors or wires until at least 3 minutes have passed.
- Diagnosis sensor unit must always be installed with their arrow marks “←” pointing towards the front of the vehicle for proper operation. Also check diagnosis sensor unit for cracks, deformities or rust before installation and replace as required.
- The spiral cable must be aligned with the neutral position since its rotations are limited. Do not attempt to turn steering wheel or column after removal of steering gear.
- Handle air bag module carefully. Always place driver and front passenger air bag modules with the pad side facing upward and front side air bag module standing with the stud bolt side facing down.
- Conduct self-diagnosis to check entire SRS for proper function after replacing any components.
- After air bag inflates, the front instrument panel assembly should be replaced if damaged.

SRS

### Wiring Diagrams and Trouble Diagnosis

EHS000JF

When you read wiring diagrams, refer to the following:

- [GI-15, "How to Read Wiring Diagrams"](#)
- [PG-3, "POWER SUPPLY ROUTING"](#) for power distribution circuit

When you perform trouble diagnosis, refer to the following:

- [GI-11, "HOW TO FOLLOW TEST GROUPS IN TROUBLE DIAGNOSES"](#)
- [GI-27, "How to Perform Efficient Diagnosis for an Electrical Incident"](#)

# PREPARATION

## PREPARATION

PFP:00002

### Special service tool

EHS000JG

The actual shapes of Kent-Moore tools may differ from those of special service tools illustrated here.

Tool number (Kent-Moore No.) Tool name	Description
— (J-44615) Air bag lock master key set  LRS210	Removing and installing air bag locking bolts

### Commercial Service Tool

EHS000JH

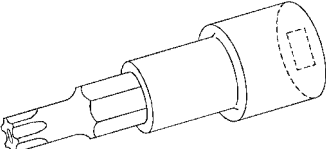
Tool name	Description
Tamper resistant torx socket  S-NT757	Size: T30

# SRS CONFIGURATION

## SRS CONFIGURATION

PFP:00000

### SRS Configuration

EHS000JI

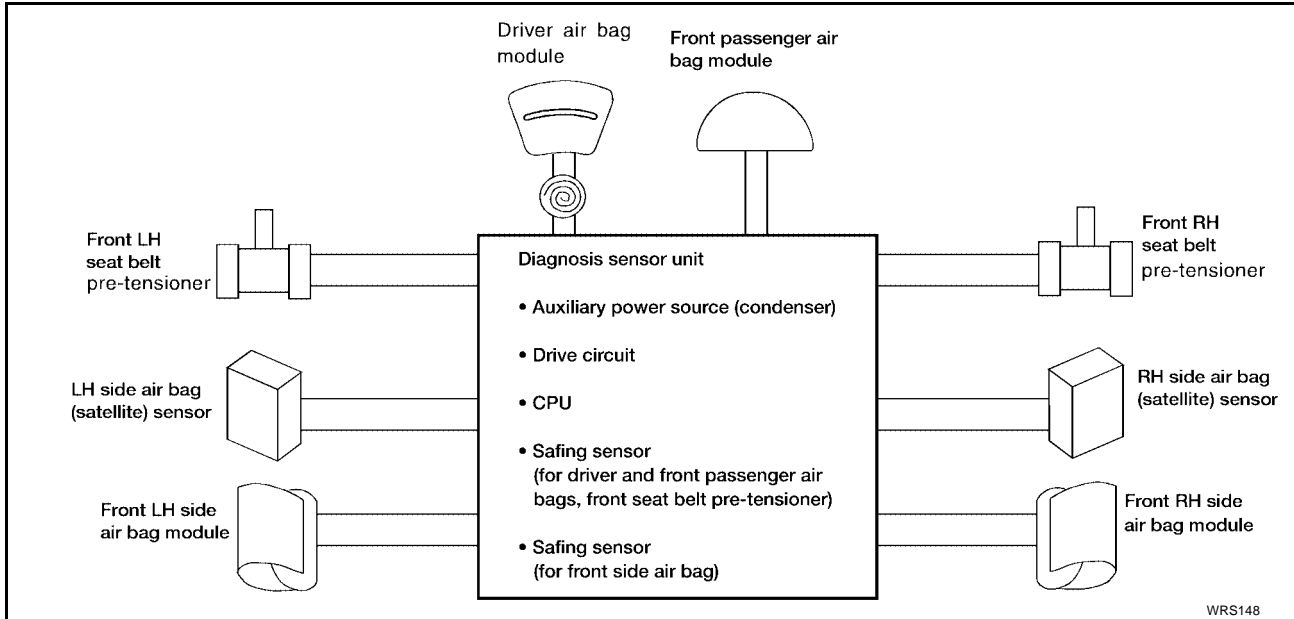

The air bag deploys if the diagnosis sensor unit activates while the ignition switch is in the "ON" or "START" position.

The collision modes for which supplemental restraint systems are activated are different among the SRS systems. For example, the driver air bag module and front passenger air bag module are activated in a frontal collision but not in a side collision.

SRS configurations which are activated for some collision modes are as follows;

SRS configuration	Frontal collision	Left side collision	Right side collision
Driver air bag module	X	—	—
Front passenger air bag module	X	—	—
Front LH seat belt pre-tensioner	X	—	—
Front RH seat belt pre-tensioner	X	—	—
Front LH side air bag module	—	X	—
Front RH side air bag module	—	—	X

A  
B  
C  
D  
E  
F  
G  
I  
J  
K  
L  
M

SRS

# SRS CONFIGURATION

## Seat Belt Pre-tensioner with Load Limiter

EHS000JJ

The front seat belt pre-tensioner system with load limiter is installed to both the driver's seat and the front passenger's seat. It operates simultaneously with the SRS air bag system in the event of a frontal collision with an impact exceeding a specified level.

When the frontal collision with an impact exceeding a specified level occurs, seat belt slack resulting from clothing or other factors is immediately taken up by the pre-tensioner. Vehicle passengers are securely restrained.

When passengers in a vehicle are thrown forward in a collision and the restraining force of the seat belt exceeds a specified level, the load limiter permits the specified extension of the seat belt by the twisting of the ELR shaft, and a relaxation of the chest-area seat belt web tension while maintaining force.

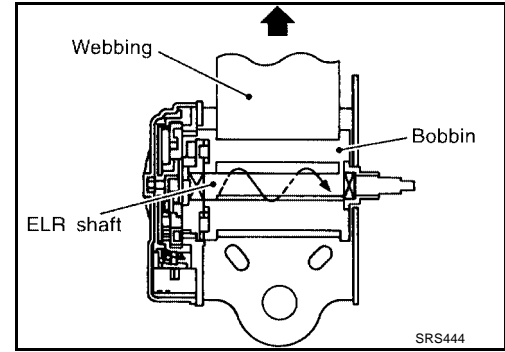

## Side Air Bag

EHS000JK

Front side air bag is built-in type.

The front seat backs with built-in type side air bag have the label shown in figure at right.

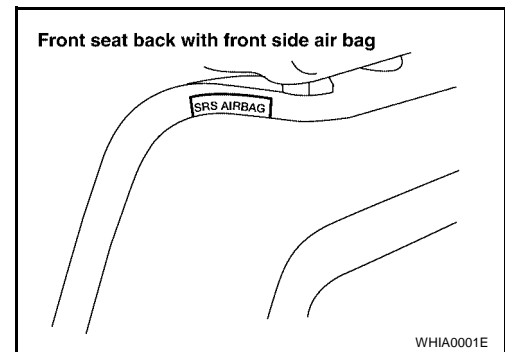

## Direct-connect SRS Component Connectors

EHS000LD

The following SRS components use direct-connect style harness connectors.

- Driver air bag module
- Front LH seat belt pre-tensioner
- Front RH seat belt pre-tensioner

Always pull up to release black locking tab prior to removing connector from SRS component.

Always push down to lock black locking tab after installing connector to SRS component. When locked, the black locking tab is level with the connector housing.

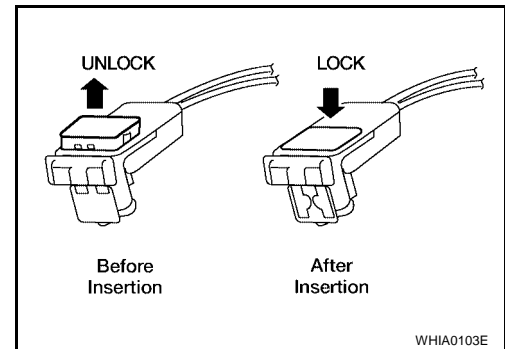

# SRS CONFIGURATION

## SRS Component Parts Location

EHS000JL

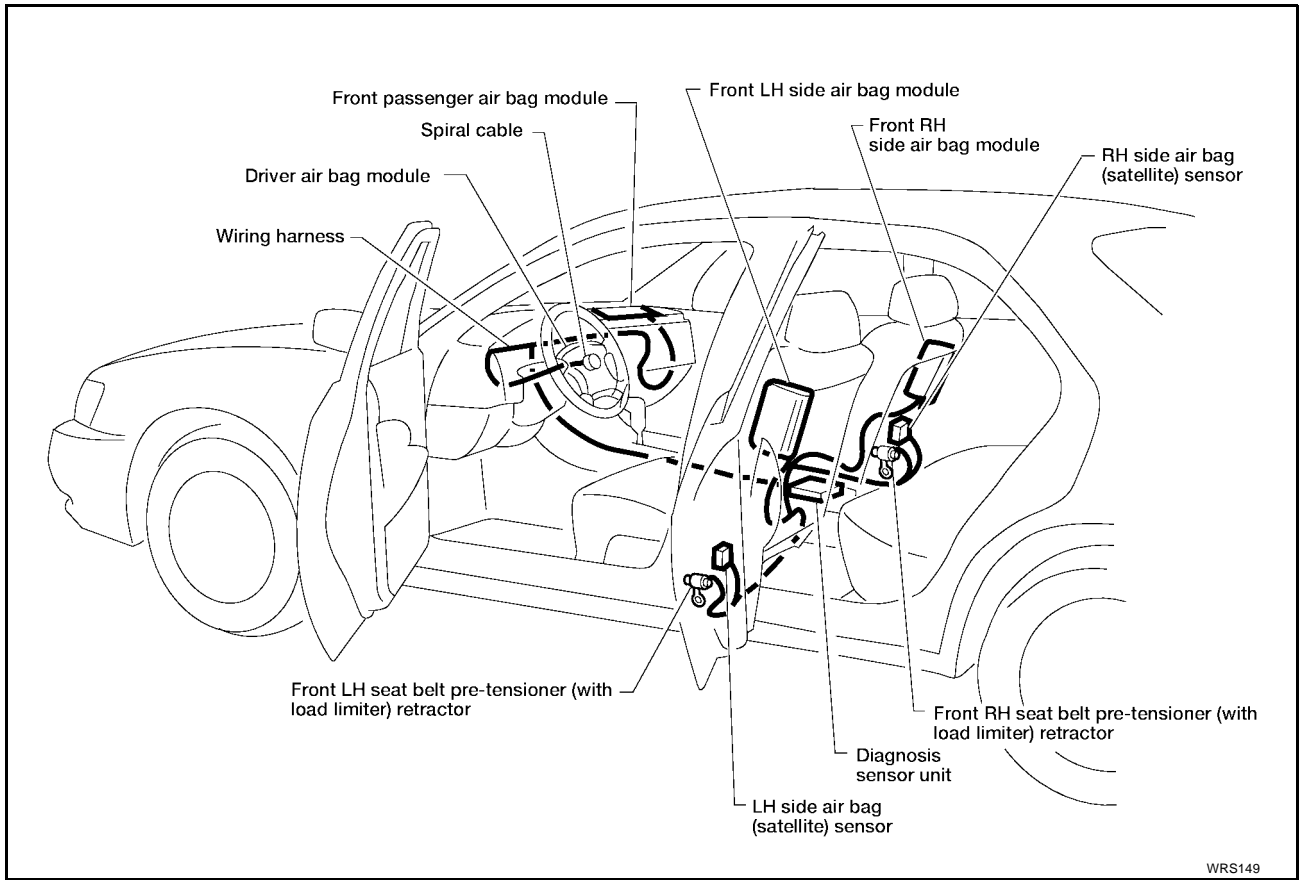

WRS149

A  
B  
C  
D  
E  
F  
G  
I  
J  
K  
L  
M

**SRS**

# TROUBLE DIAGNOSIS

## TROUBLE DIAGNOSIS

PF0:00004

### Trouble Diagnoses Introduction

EHS000JM

#### CAUTION:

- Do not use electrical test equipment on any circuit related to the SRS unless instructed to in this Service Manual. SRS wiring harnesses can be identified by yellow and/or orange harness connectors.
- Do not attempt to repair, splice or modify the SRS wiring harness. If the harness is damaged, replace it with a new one.
- Keep ground portion clean.

#### DIAGNOSIS FUNCTION

The SRS self-diagnosis results can be read by using "AIR BAG" warning lamp and/or CONSULT-II. The reading of these results is accomplished using one of two modes — "User mode" and "Diagnosis mode".

The User mode is exclusively prepared for the customer (driver). This mode warns the driver of a system malfunction through the operation of the "AIR BAG" warning lamp.

The Diagnosis mode allows the technician to locate and inspect the malfunctioning part.

The mode applications for the "AIR BAG" warning lamp and CONSULT-II are as follows:

	User mode	Diagnosis mode	Display type
"AIR BAG" warning lamp	X	X	ON-OFF operation
CONSULT-II	—	X	Monitoring



# TROUBLE DIAGNOSIS

## ④ HOW TO CHANGE SELF-DIAGNOSIS MODE WITH CONSULT-II

### From User Mode to Diagnosis Mode

After selecting “AIR BAG” on the “SELECT SYSTEM” screen, User mode automatically changes to Diagnosis mode.

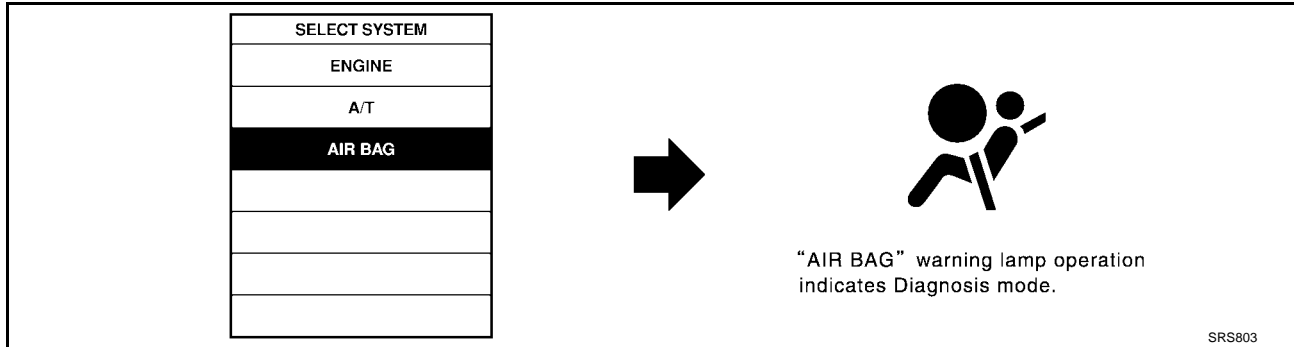

### From Diagnosis Mode to User Mode

To return to User mode from Diagnosis mode, touch “BACK” key of CONSULT-II until “SELECT SYSTEM” appears, Diagnosis mode automatically changes to User mode.

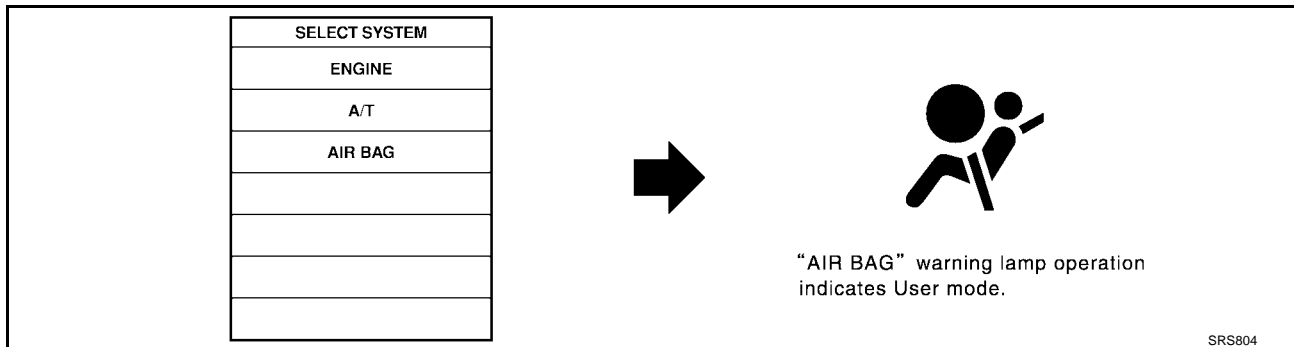

## ⊗ HOW TO CHANGE SELF-DIAGNOSIS MODE WITHOUT CONSULT-II

### From User Mode to Diagnosis Mode

Diagnosis mode activates only when a malfunction is detected, by turning ignition switch as follows:

1. Turn ignition switch “ON”.
2. After “AIR BAG” warning lamp lights for 7 seconds, turn ignition switch “OFF” within 1 second.
3. Wait more than 3 seconds.
4. Repeat steps 1 to 3 three times.
5. Turn ignition switch “ON”.

SRS will enter Diagnosis mode, if a malfunction is detected.

### From Diagnosis Mode to User Mode

After a malfunction is repaired, turn ignition switch “OFF” for at least one second, then back “ON”. Diagnosis mode is returned to User mode.

If switching Diagnosis mode to User mode is required while malfunction is being detected, turn ignition switch as follows:

1. Turn ignition switch “ON”.
2. After “AIR BAG” warning lamp lights for 7 seconds, turn ignition switch “OFF” within 1 second.
3. Wait more than 3 seconds.
4. Repeat steps 1 to 3 three times.
5. Turn ignition switch “ON”.

## HOW TO ERASE SELF-DIAGNOSIS RESULTS

### ④ With CONSULT-II

- “SELF-DIAG [CURRENT]”  
A current Self-diagnosis result is displayed on the CONSULT-II screen in real time.

# TROUBLE DIAGNOSIS

After the malfunction is repaired completely, no malfunction is detected on "SELF-DIAG [CURRENT]".

- "SELF-DIAG [PAST]"  
Return to the "SELF-DIAG [CURRENT]" CONSULT-II screen by pushing "BACK" key of CONSULT-II and select "SELF-DIAG [CURRENT]" in SELECT DIAG MODE. Touch "ERASE" in "SELF-DIAG [CURRENT]" mode.

**NOTE:**

If the memory of the malfunction in "SELF-DIAG [PAST]" is not erased, the User mode shows the system malfunction by the operation of the warning lamp even if the malfunction is repaired completely.

- "TROUBLE DIAG RECORD"  
The memory of "TROUBLE DIAG RECORD" cannot be erased.

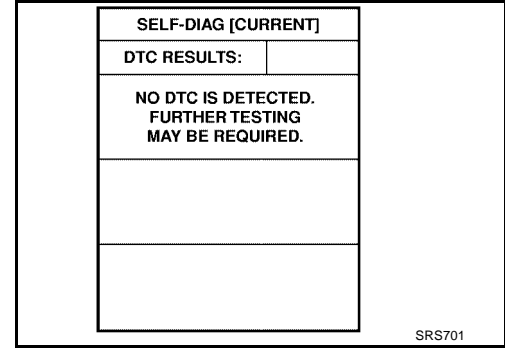

⊗ **Without CONSULT-II**

After a malfunction is repaired, switch the ignition "OFF" for at least one second, then back "ON". Diagnosis mode returns to the User mode. At that time, the self-diagnostic result is cleared.

# TROUBLE DIAGNOSIS

## CONSULT-II Function (AIR BAG)

EHS0017A

CONSULT-II can display each diagnostic item using the diagnostic test modes shown following.

AIR BAG diagnostic mode	Description
SELF-DIAG [CURRENT]	A current Self-diagnosis result (also indicated by the number of warning lamp flashes in the Diagnosis mode) is displayed on the CONSULT-II screen in real time. This refers to a malfunctioning part requiring repairs.
SELF-DIAG [PAST]	Diagnosis results previously stored in the memory are displayed on the CONSULT-II screen. The stored results will remain until memory erasing is executed.
TROUBLE DIAG RECORD	With TROUBLE DIAG RECORD, diagnosis results previously erased by a reset operation can be displayed on the CONSULT-II screen.
ECU DISCRIMINATED NO.	<p>The diagnosis sensor unit for each vehicle model is assigned with its own, individual classification number. This number will be displayed on the CONSULT-II screen, as shown. When replacing the diagnosis sensor unit, refer to the part number for the compatibility. After installation, replacement with a correct unit can be checked by confirming this classification number on the CONSULT-II screen.</p> <p><b>For NISSAN MODEL B15, the diagnosis sensor unit discriminated numbers assigned are A616 (for models with side air bags) and A615 (for models without side air bags).</b></p> <div style="border: 1px solid black; padding: 5px; margin-top: 10px;"> <div style="text-align: center; border: 1px solid black; padding: 5px;"> <p>ECU DISCRIMINATED NO.</p> <p>ECU No. XXXX</p> </div> <div style="text-align: center; border: 1px solid black; padding: 2px;"> <p>PRINT</p> </div> <div style="display: flex; justify-content: center; gap: 10px;"> <div style="border: 1px solid black; padding: 2px 5px;">BACK</div> <div style="border: 1px solid black; padding: 2px 5px;">LIGHT</div> <div style="border: 1px solid black; padding: 2px 5px;">COPY</div> </div> <p style="text-align: right; font-size: small;">ARS366</p> </div>

A  
B  
C  
D  
E  
F  
G  
I  
J  
K  
L  
M

SRS

# TROUBLE DIAGNOSIS

---

## How to Perform Trouble Diagnoses for Quick and Accurate Repair

EHS000JN

A good understanding of the malfunction conditions can make troubleshooting faster and more accurate. In general, each customer feels differently about a malfunction. It is important to fully understand the symptoms or conditions for a customer complaint.

### INFORMATION FROM CUSTOMER

WHAT ..... Vehicle model

WHEN ..... Date, Frequencies

WHERE ..... Road conditions

HOW ..... Operating conditions, Symptoms

### PRELIMINARY CHECK

Check that the following parts are in good order.

- Battery [Refer to [SC-4, "BATTERY"](#) .]
- Fuse
- System component-to-harness connections

# TROUBLE DIAGNOSIS

## WORK FLOW

### NOTE:

Seat belt pre-tensioner malfunction is indicated by "AIR BAG" warning lamp.

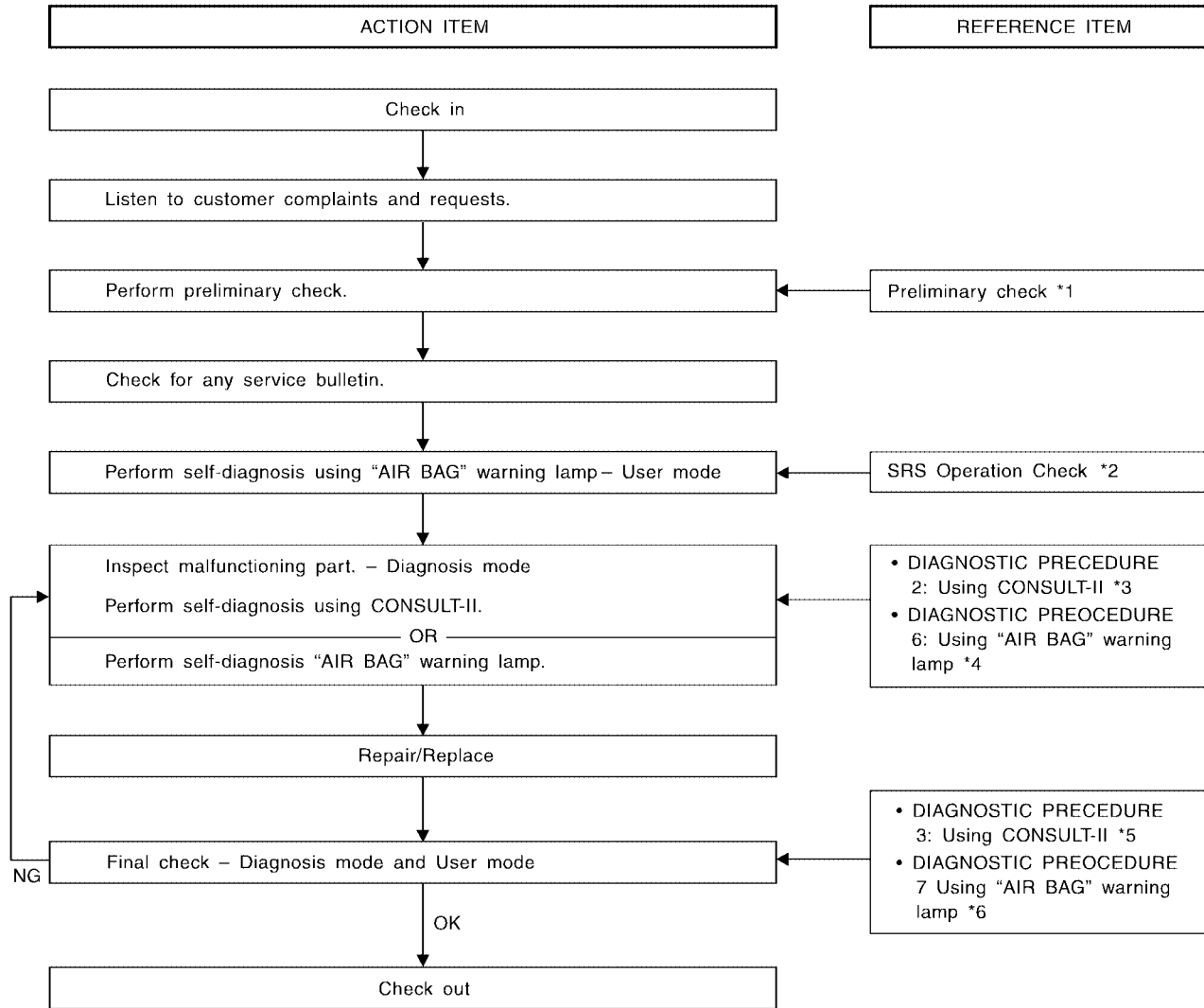

A  
B  
C  
D  
E  
F  
G  
SRS  
I  
J  
K  
L  
M

\*1: [SRS-12](#)

\*2: [SRS-18](#)

\*3: [SRS-18](#)

\*4: [SRS-29](#)

\*5: [SRS-22](#)

\*6: [SRS-34](#)

WRS155

# TROUBLE DIAGNOSIS

## Schematic

EHS000JO

(SA) : WITH SIDE AIR BAGS

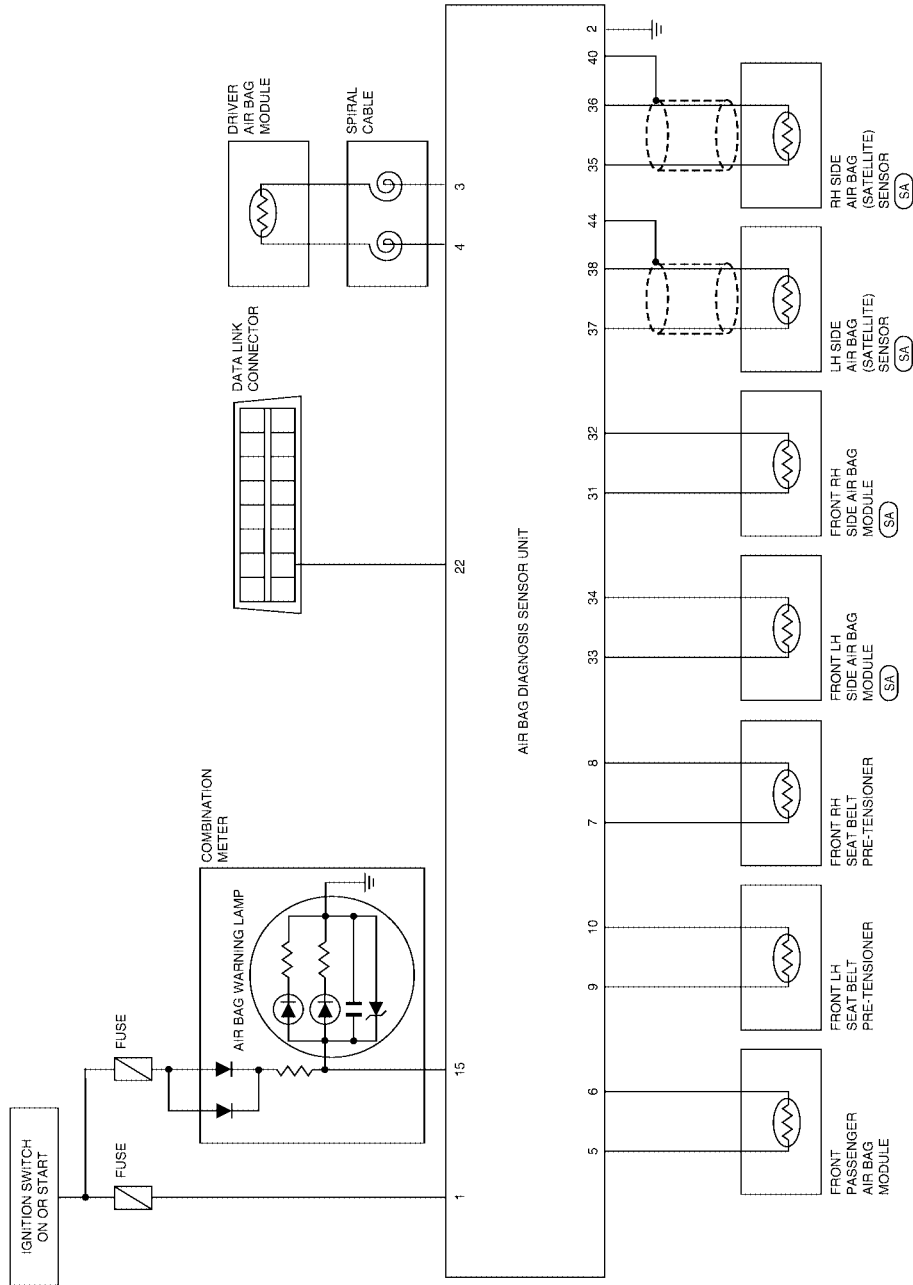

# TROUBLE DIAGNOSIS

## Wiring Diagram — SRS —

EHS000JP

### SRS-SRS-01

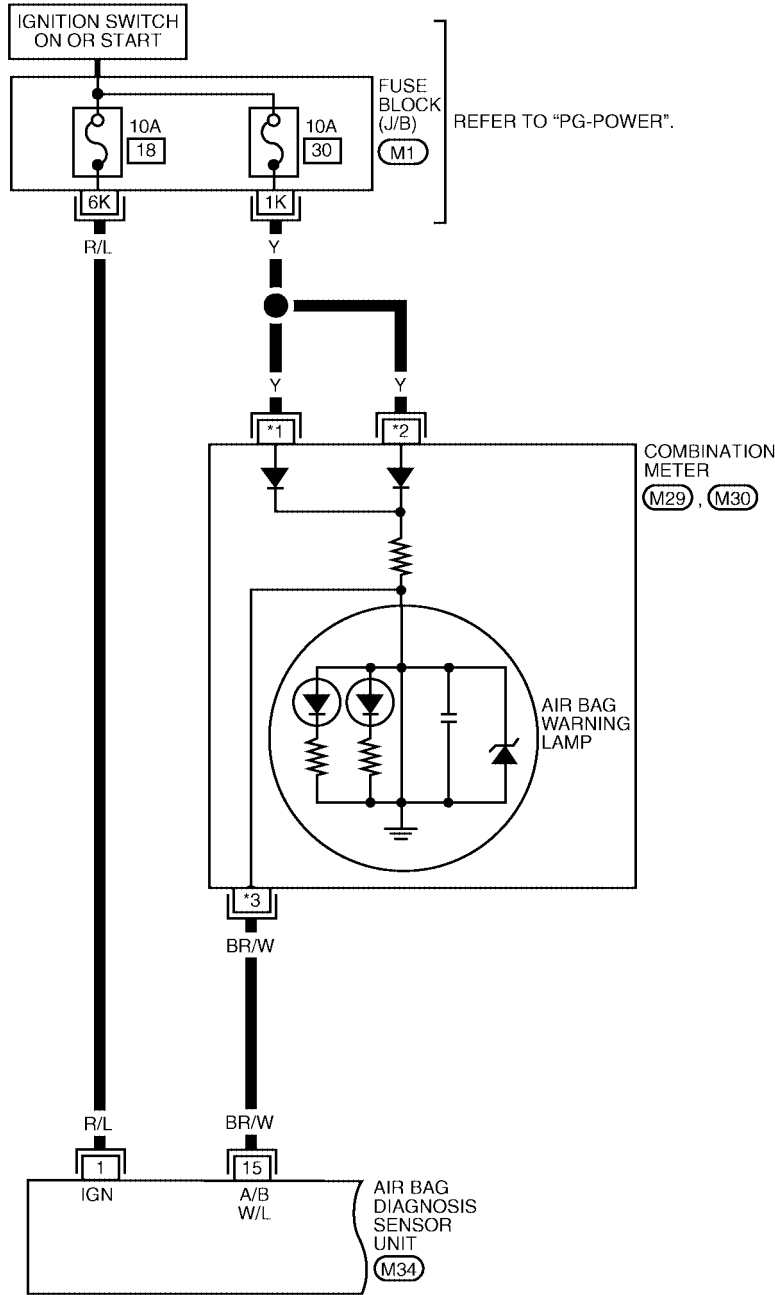

- ◊EK : WITHOUT TACHOMETER
- ◊GT : QG18DE ENGINE WITH TACHOMETER
- ◊QR : WITH QR25DE ENGINE
- ◊TK : WITH TACHOMETER
- \*1 ◊EK : 20
- ◊GT : 6
- ◊QR : 7
- \*2 ◊EK : 26
- ◊GT : 41
- ◊QR : 14
- \*3 ◊EK : 16
- ◊GT : 1
- ◊QR : 1

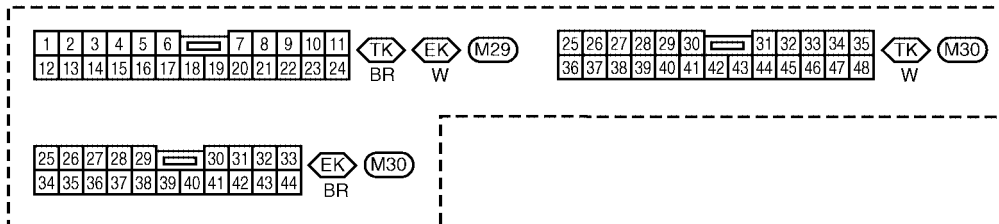
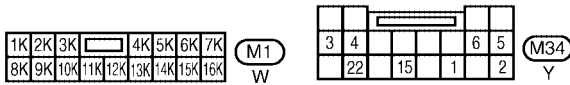

WHWA0085E

# TROUBLE DIAGNOSIS

SRS-SRS-02

◊SA◊ : WITH SIDE AIR BAGS

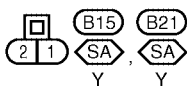
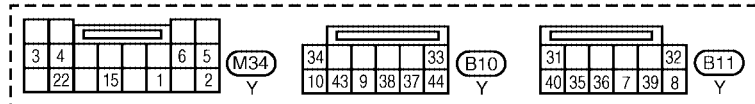
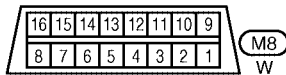
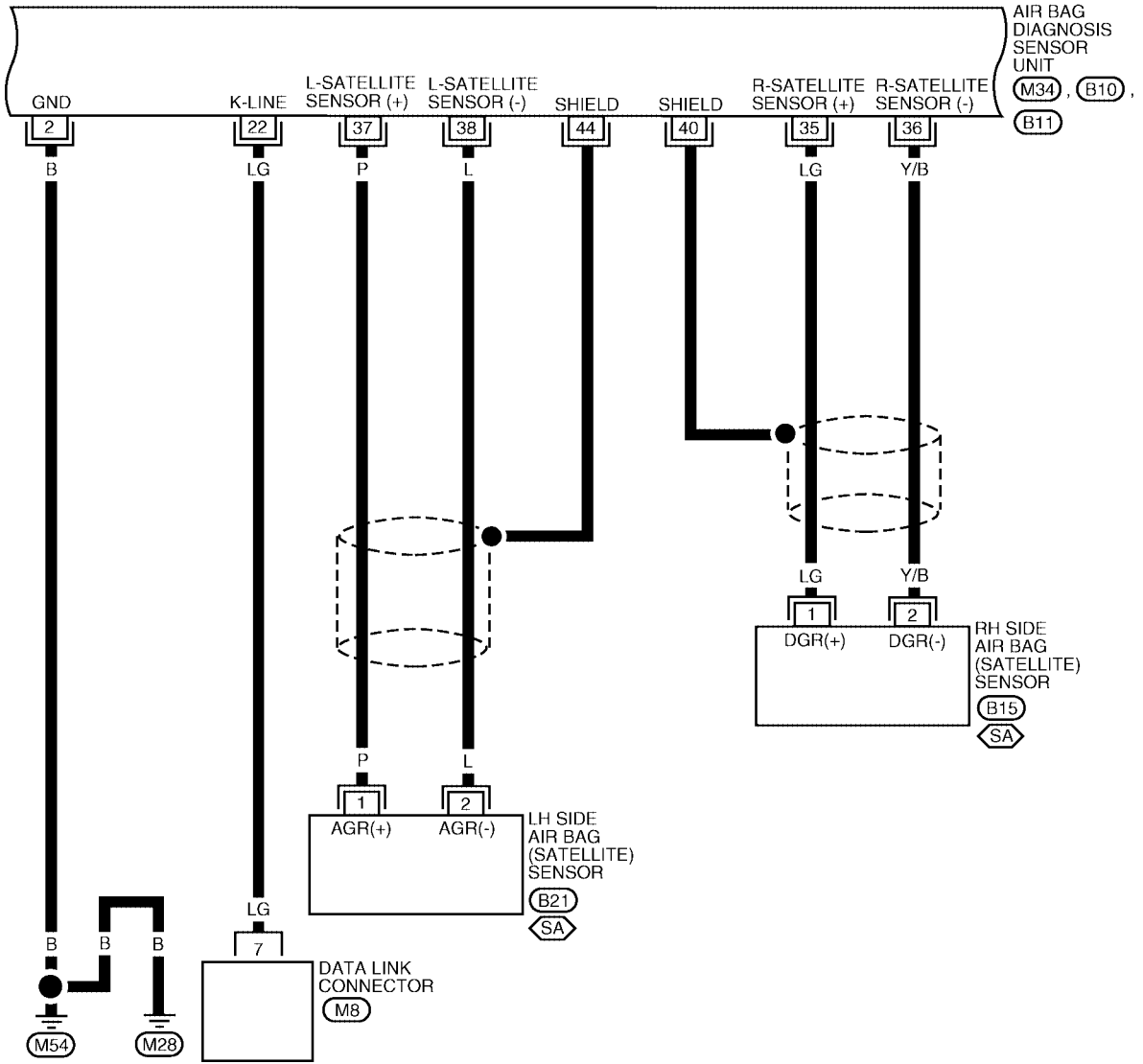

WHWA0086E



# TROUBLE DIAGNOSIS

SRS-SRS-03

A  
B  
C  
D  
E  
F  
G  
H  
I  
J  
K  
L  
M

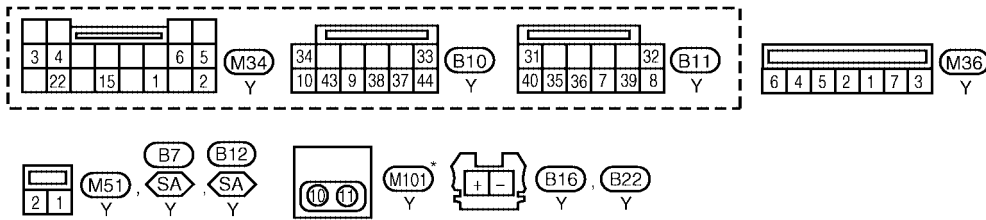
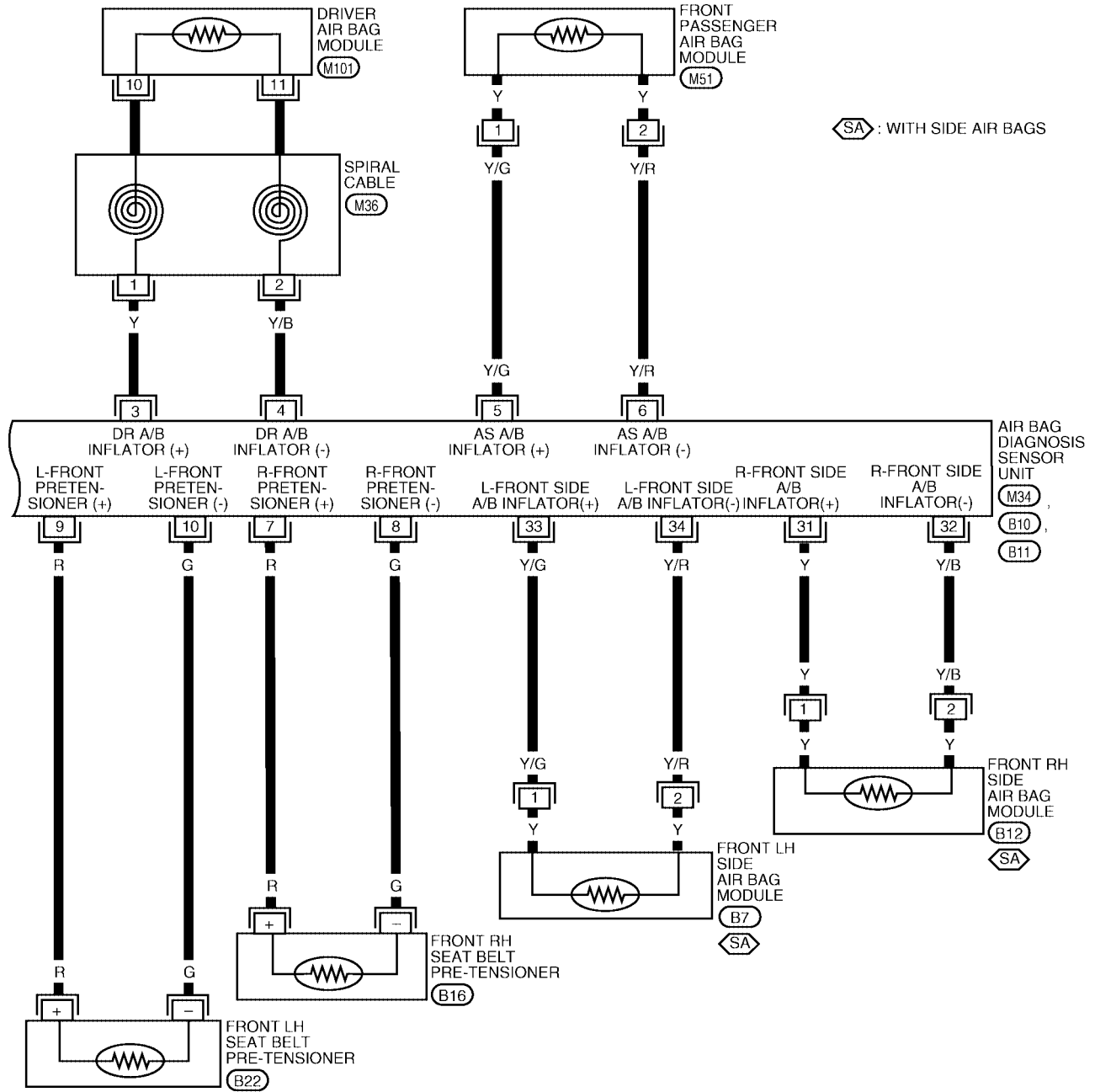

\* THIS CONNECTOR IS NOT SHOWN IN "HARNESS LAYOUT " OF PG SECTION.

WHWA0087E

# TROUBLE DIAGNOSIS

EHS000JQ

## SRS Operation Check DIAGNOSTIC PROCEDURE 1

### Checking Air Bag Operation by Using "AIR BAG" Warning Lamp — User Mode

1. After turning ignition switch from "OFF" to "ON", "AIR BAG" warning lamp operates.
2. Compare "AIR BAG" warning lamp operation to the chart below.

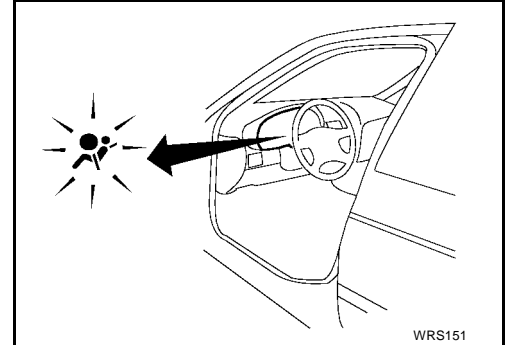

WRS151

"AIR BAG" warning lamp operation — User mode —	SRS condition	Reference item
<p>MRS095A</p>	No malfunction is detected. No further action is necessary.	—
<p>MRS096A</p>	The system is malfunctioning and needs to be repaired as indicated.	Go to <a href="#">SRS-18, "DIAGNOSTIC PROCEDURE 2"</a> or <a href="#">SRS-29, "DIAGNOSTIC PROCEDURE 6"</a> .
<p>MRS097A</p>	<p>Air bag is deployed. Front seat belt pre-tensioner is deployed.</p> <p>Air bag fuse, diagnosis sensor unit or harness is malfunctioning and needs to be repaired.</p>	<p>Go to <a href="#">SRS-47, "COLLISION DIAGNOSIS"</a>.</p> <p>Go to <a href="#">SRS-36, "DIAGNOSTIC PROCEDURE 9"</a>.</p>
<p>MRS098A</p>	<p>One of the following has occurred and needs to be repaired.</p> <ul style="list-style-type: none"> <li>● Meter fuse is blown.</li> <li>● "AIR BAG" warning lamp circuit has open or short.</li> <li>● Diagnosis sensor unit is malfunctioning.</li> </ul>	Go to <a href="#">SRS-37, "DIAGNOSTIC PROCEDURE 10"</a> .

## Ⓜ Trouble Diagnoses with CONSULT-II DIAGNOSTIC PROCEDURE 2

EHS000JR

### Inspecting SRS malfunctioning parts by using CONSULT-II — Diagnosis mode

#### CAUTION:

If CONSULT-II is used with no connection of CONSULT-II CONVERTER, malfunction might be detected in self-diagnosis depending on control unit which carry out CAN communication.

# TROUBLE DIAGNOSIS

1. Turn ignition switch OFF.
2. Connect CONSULT-II to the data link connector.

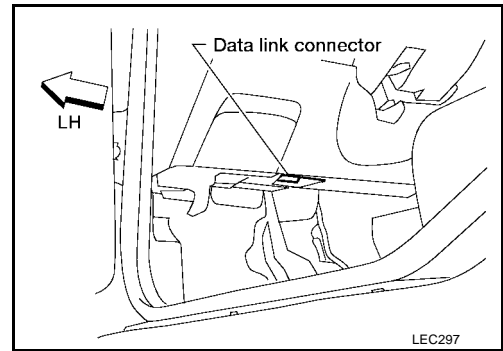

3. Turn ignition switch ON.
4. Touch "START (NISSAN BASED VHCL)".

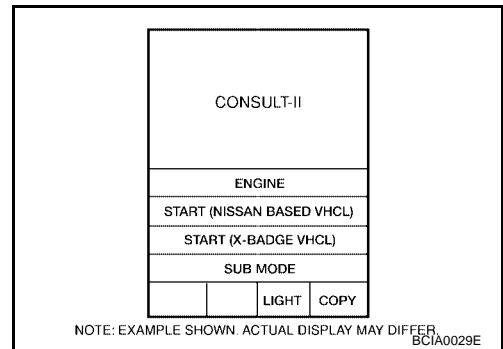

5. Touch "AIR BAG".  
If "AIR BAG" is not indicated, refer to [GI-39, "CONSULT-II Data Link Connector \(DLC\) Circuit"](#) .

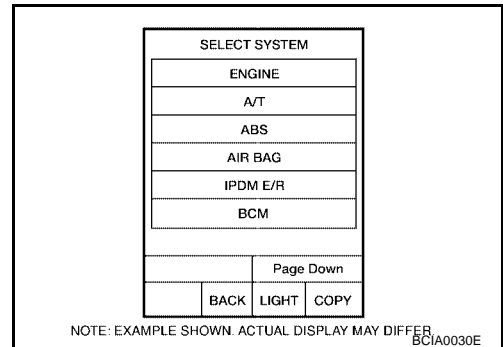

6. Touch "SELF-DIAG [CURRENT]".

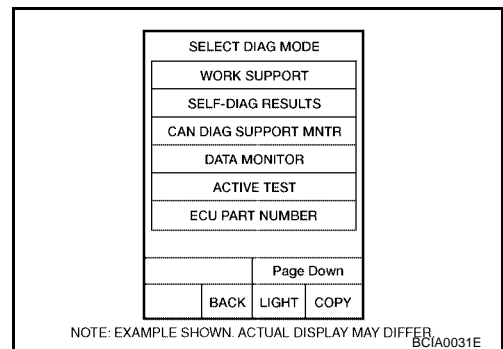

A  
B  
C  
D  
E  
F  
G  
I  
J  
K  
L  
M

SRS

# TROUBLE DIAGNOSIS

7. Diagnostic code is displayed on "SELF-DIAG [CURRENT]".

SELF-DIAG [CURRENT]
DTC RESULTS
DRIVER AIRBAG MODULE [OPEN] [B1049]

WHIA0151E

If no malfunction is detected on "SELF-DIAG [CURRENT]" even though malfunction is detected in "SRS Operation Check", refer to [SRS-24, "DIAGNOSTIC PROCEDURE 4 \(CONTINUED FROM DIAGNOSTIC PROCEDURE 2\)"](#) , to diagnose the following cases:

- Self-diagnostic result "SELF-DIAG [PAST]" (previously stored in the memory) might not be erased after repair.
  - The SRS system malfunctions intermittently.
8. Touch "PRINT".
9. Compare diagnostic codes. Refer to [SRS-20, "CONSULT-II Diagnostic Code Chart \("SELF-DIAG \[CURRENT\]\)"](#) .

SELF-DIAG [CURRENT]
DTC RESULTS:
NO DTC IS DETECTED. FURTHER TESTING MAY BE REQUIRED.

SRS701

10. Touch "BACK" key of CONSULT-II until "SELECT SYSTEM" appears in order to return to User mode from Diagnosis mode.
11. Turn ignition switch "OFF", then turn off and disconnect CONSULT-II and disconnect both battery cables.
12. Repair the system as outlined by the "Repair order" in "CONSULT-II Diagnostic Code Chart", that corresponds to the self-diagnostic result.
13. After repairing the system, refer to [SRS-22, "DIAGNOSTIC PROCEDURE 3"](#) for final checking.

## CONSULT-II Diagnostic Code Chart ("SELF-DIAG [CURRENT])"

Diagnostic item	Explanation	Repair order <b>Recheck SRS at each replacement.</b>
NO DTC IS DETECTED.	When malfunction is indicated by the "AIR BAG" warning lamp in User mode	<ul style="list-style-type: none"> <li>● Self-diagnostic result "SELF-DIAG [PAST]" (previously stored in the memory) might not be erased after repair.</li> <li>● Intermittent malfunction has been detected in the past.</li> </ul>
	<ul style="list-style-type: none"> <li>● Low battery voltage (Less than 9V)</li> </ul>	<ul style="list-style-type: none"> <li>● Go to <a href="#">SRS-24, "DIAGNOSTIC PROCEDURE 4 (CONTINUED FROM DIAGNOSTIC PROCEDURE 2)"</a> .</li> <li>● Go to <a href="#">SRS-22, "DIAGNOSTIC PROCEDURE 3"</a> after charging battery.</li> </ul>
	<ul style="list-style-type: none"> <li>● No malfunction is detected.</li> </ul>	<ul style="list-style-type: none"> <li>● Go to <a href="#">SRS-22, "DIAGNOSTIC PROCEDURE 3"</a> .</li> </ul>

# TROUBLE DIAGNOSIS

Diagnostic item	Explanation	Repair order <b>Recheck SRS at each replacement.</b>	
DRIVER AIR BAG MODULE [OPEN] [B1049]	● Driver air bag module circuit is open. (including the spiral cable)	<ol style="list-style-type: none"> <li>1. Visually check the wiring harness connection.</li> <li>2. Replace the harness if it has visible damage.</li> <li>3. Replace the spiral cable.</li> <li>4. Replace driver air bag module. (Before disposal, it must be deployed.)</li> <li>5. Replace the diagnosis sensor unit.</li> <li>6. Replace the related harness.</li> </ol>	A
DRIVER AIR BAG MODULE [VB-SHORT] [B1050]	● Driver air bag module circuit is shorted to some power supply circuit. (including the spiral cable)		B
DRIVER AIR BAG MODULE [GND-SHORT] [B1051]	● Driver air bag module circuit is shorted to ground. (including the spiral cable)		C
DRIVER AIR BAG MODULE [SHORT] [B1052]	● Driver air bag module circuits are shorted to each other.		D
ASSIST A/B MODULE [OPEN] [B1065]	● Front passenger air bag module circuit is open.	<ol style="list-style-type: none"> <li>1. Visually check the wiring harness connection.</li> <li>2. Replace the harness if it has visible damage.</li> <li>3. Replace front passenger air bag module. (Before disposal, it must be deployed.)</li> <li>4. Replace the diagnosis sensor unit.</li> <li>5. Replace the related harness.</li> </ol>	E
ASSIST A/B MODULE [VB-SHORT] [B1066]	● Front passenger air bag module circuit is shorted to some power supply circuit.		F
ASSIST A/B MODULE [GND-SHORT] [B1067]	● Front passenger air bag module circuit is shorted to ground.		G
ASSIST A/B MODULE [SHORT] [B1068]	● Front passenger air bag module circuits are shorted to each other.		SRS
SIDE MODULE LH [OPEN] [B1134]	● Front LH side air bag module circuit is open.	<ol style="list-style-type: none"> <li>1. Visually check the wiring harness connection.</li> <li>2. Replace the harness if it has visible damage.</li> <li>3. Replace front LH seatback assembly. (Before disposal, it must be deployed.)</li> <li>4. Replace the diagnosis sensor unit.</li> <li>5. Replace the related harness.</li> </ol>	I
SIDE MODULE LH [VB-SHORT] [B1135]	● Front LH side air bag module circuit is shorted to some power supply circuits.		J
SIDE MODULE LH [GND-SHORT] [B1136]	● Front LH side air bag module circuit is shorted to ground.		K
SIDE MODULE LH [SHORT] [B1137]	● Front LH side air bag module circuits are shorted to each other.		L
SIDE MODULE RH [OPEN] [B1129]	● Front RH side air bag module circuit is open.	<ol style="list-style-type: none"> <li>1. Visually check the wiring harness connection.</li> <li>2. Replace the harness if it has visible damage.</li> <li>3. Replace front RH seatback assembly. (Before disposal, it must be deployed.)</li> <li>4. Replace the diagnosis sensor unit.</li> <li>5. Replace the related harness.</li> </ol>	M
SIDE MODULE RH [VB-SHORT] [B1130]	● Front RH side air bag module circuit is shorted to some power supply circuits.		M
SIDE MODULE RH [GND-SHORT] [B1131]	● Front RH side air bag module circuit is shorted to ground.		M
SIDE MODULE RH [SHORT] [B1132]	● Front RH side air bag module circuits are shorted to each other.		M

# TROUBLE DIAGNOSIS

Diagnostic item	Explanation	Repair order <b>Recheck SRS at each replacement.</b>
SATELLITE SENS LH [UNIT FAIL] [B1118] or [B1119] SATELLITE SENS LH [COMM FAIL] [B1120]	<ul style="list-style-type: none"> <li>LH side air bag (satellite) sensor</li> </ul>	<ol style="list-style-type: none"> <li>1. Visually check the wiring harness connection.</li> <li>2. Replace the harness if it has visible damage.</li> <li>3. Replace the LH side air bag (satellite) sensor.</li> <li>4. Replace the diagnosis sensor unit.</li> <li>5. Replace the related harness.</li> </ol>
SATELLITE SENS RH [UNIT FAIL] [B1113] or [B1114] SATELLITE SENS RH [COMM FAIL] [B1115]	<ul style="list-style-type: none"> <li>RH side air bag (satellite) sensor</li> </ul>	<ol style="list-style-type: none"> <li>1. Visually check the wiring harness connection.</li> <li>2. Replace the harness if it has visible damage.</li> <li>3. Replace the RH side air bag (satellite) sensor.</li> <li>4. Replace the diagnosis sensor unit.</li> <li>5. Replace the related harness.</li> </ol>
PRE-TEN FRONT LH [OPEN] [B1086]	<ul style="list-style-type: none"> <li>The circuit for the front LH pre-tensioner is open to some power supply circuit.</li> </ul>	<ol style="list-style-type: none"> <li>1. Visually check the wiring harness connections.</li> <li>2. Replace the harness if it has visible damage.</li> <li>3. Replace the front LH seat belt. (Before disposal, it must be deployed.)</li> <li>4. Replace the diagnosis sensor unit.</li> <li>5. Replace the related harness.</li> </ol>
PRE-TEN FRONT LH [VB-SHORT] [B1087]	<ul style="list-style-type: none"> <li>The circuit for the front LH pre-tensioner is shorted to some power supply circuit.</li> </ul>	
PRE-TEN FRONT LH [GND-SHORT] [B1088]	<ul style="list-style-type: none"> <li>The circuit for the front LH pre-tensioner is shorted to ground.</li> </ul>	
PRE-TEN FRONT LH [SHORT] [B1089]	<ul style="list-style-type: none"> <li>The circuits for the front LH pre-tensioner are shorted to each other.</li> </ul>	
PRE-TEN FRONT RH [OPEN] [B1081]	<ul style="list-style-type: none"> <li>The circuit for the front RH pre-tensioner is open to some power supply circuit.</li> </ul>	
PRE-TEN FRONT RH [VB-SHORT] [B1082]	<ul style="list-style-type: none"> <li>The circuit for the front RH pre-tensioner is shorted to some power supply circuit.</li> </ul>	<ol style="list-style-type: none"> <li>1. Visually check the wiring harness connections.</li> <li>2. Replace the harness if it has visible damage.</li> <li>3. Replace the front RH seat belt. (Before disposal, it must be deployed.)</li> <li>4. Replace the diagnosis sensor unit.</li> <li>5. Replace the related harness.</li> </ol>
PRE-TEN FRONT RH [GND-SHORT] [B1083]	<ul style="list-style-type: none"> <li>The circuit for the front RH pre-tensioner is shorted to ground.</li> </ul>	
PRE-TEN FRONT RH [SHORT] [B1084]	<ul style="list-style-type: none"> <li>The circuits for the front RH pre-tensioner are shorted to each other.</li> </ul>	
CONTROL UNIT [B1XXX]	<ul style="list-style-type: none"> <li>Diagnosis sensor unit is malfunctioning.</li> </ul>	

Follow the procedures in numerical order when repairing malfunctioning parts. Confirm whether malfunction is eliminated using the air bag warning lamp or CONSULT-II each time repair is finished. If malfunction is still observed, proceed to the next step. When malfunction is eliminated, further repair work is not required.

## DIAGNOSTIC PROCEDURE 3

Final checking after repairing SRS by using CONSULT-II — Diagnosis mode

### CAUTION:

If CONSULT-II is used with no connection of CONSULT-II CONVERTER, malfunction might be detected in self-diagnosis depending on control unit which carry out CAN communication.

# TROUBLE DIAGNOSIS

1. After repairing SRS, connect both battery cables.
2. Connect CONSULT-II to data link connector.
3. Turn ignition switch ON.

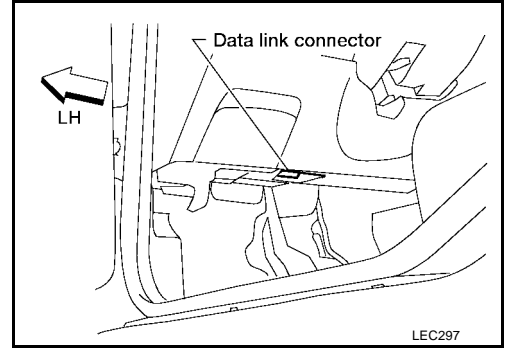

4. Touch "START (NISSAN BASED VHCL)".

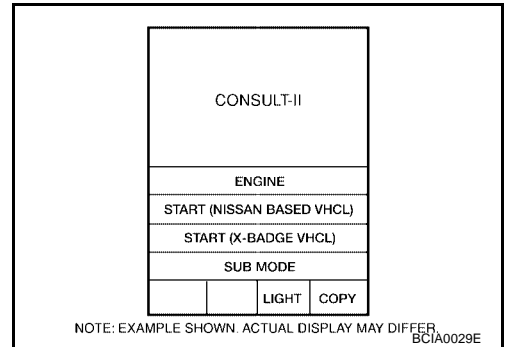

5. Touch "AIR BAG".  
If "AIR BAG" is not indicated, refer to [GI-39, "CONSULT-II Data Link Connector \(DLC\) Circuit"](#).

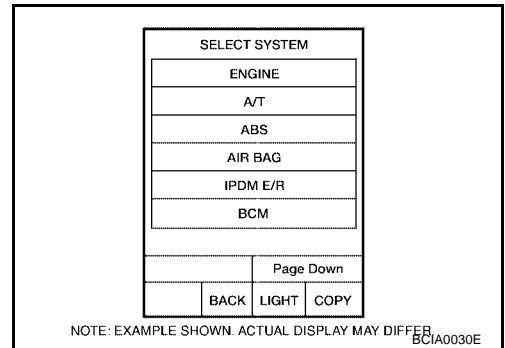

6. Touch "SELF-DIAG [CURRENT]".

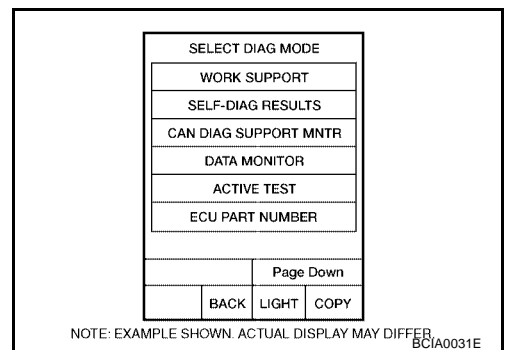

A  
B  
C  
D  
E  
F  
G  
**SRS**  
I  
J  
K  
L  
M

# TROUBLE DIAGNOSIS

7. If no malfunction is detected on "SELF-DIAG [CURRENT]", repair of SRS is completed. Go to step 8.  
If any malfunction is detected on "SELF-DIAG [CURRENT]", the malfunctioning part is not repaired completely or another malfunctioning part is detected. Go to [SRS-18, "DIAGNOSTIC PROCEDURE 2"](#), and repair malfunctioning part completely.

SELF-DIAG [CURRENT]	
DTC RESULTS:	
NO DTC IS DETECTED. FURTHER TESTING MAY BE REQUIRED.	

SRS701

8. Touch "ERASE".

**NOTE:**

**Touch "ERASE" to clear the memory of the malfunction ("SELF-DIAG [PAST])."**

If the memory of the malfunction in "SELF-DIAG [PAST]" is not erased, the User mode shows the system malfunction by the operation of the warning lamp even if the malfunction is repaired completely.

SELF-DIAG [PAST]	
DTC RESULTS	
DRIVER AIRBAG MODULE [OPEN] [B1049]	

WHIA0152E

9. Touch "BACK" key of CONSULT-II to "SELECT DIAG MODE" screen. Touch "SELF-DIAG [PAST]".

SELECT DIAG MODE		
WORK SUPPORT		
SELF-DIAG RESULTS		
CAN DIAG SUPPORT MNTR		
DATA MONITOR		
ACTIVE TEST		
ECU PART NUMBER		
		Page Down
BACK	LIGHT	COPY

NOTE: EXAMPLE SHOWN. ACTUAL DISPLAY MAY DIFFER.  
ECIA0031E

10. Check that no malfunction is detected on "SELF-DIAG [PAST]".  
11. Touch "BACK" key of CONSULT-II until "SELECT SYSTEM" appears in order to return to User mode from Diagnosis mode.  
12. Turn ignition switch OFF then turn off and disconnect CONSULT-II.  
13. Go to [SRS-18, "Checking Air Bag Operation by Using "AIR BAG" Warning Lamp — User Mode"](#).

SELF-DIAG [PAST]	
DTC RESULTS:	
NO DTC IS DETECTED. FURTHER TESTING MAY BE REQUIRED.	

SRS702

## DIAGNOSTIC PROCEDURE 4 (CONTINUED FROM DIAGNOSTIC PROCEDURE 2) Inspecting SRS malfunctioning record

### 1. CONSIDER POSSIBILITY OF NOT ERASING SELF-DIAGNOSTIC RESULT AFTER REPAIRING

Is it the first time for maintenance of SRS?

Yes or No

Yes >> Go to [SRS-25, "DIAGNOSTIC PROCEDURE 5"](#).

No >> Self-diagnostic result "SELF-DIAG [PAST]" (previously stored in the memory) might not be erased after repair. Go to [SRS-22, "DIAGNOSTIC PROCEDURE 3"](#).



# TROUBLE DIAGNOSIS

## DIAGNOSTIC PROCEDURE 5

### Inspecting SRS intermittent malfunction by using CONSULT-II — Diagnosis mode

**CAUTION:**

If CONSULT-II is used with no connection of CONSULT-II CONVERTER, malfunction might be detected in self-diagnosis depending on control unit which carry out CAN communication.

1. Turn ignition switch OFF.
2. Connect CONSULT-II to data link connector.

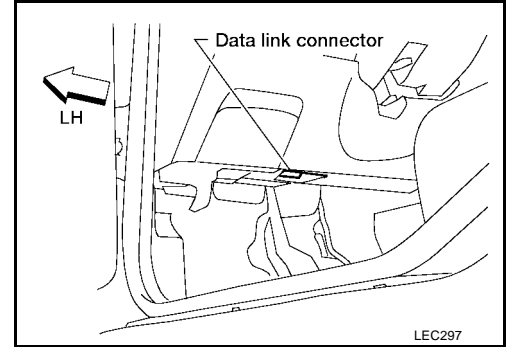

3. Turn ignition switch ON.
4. Touch "START (NISSAN BASED VHCL)".

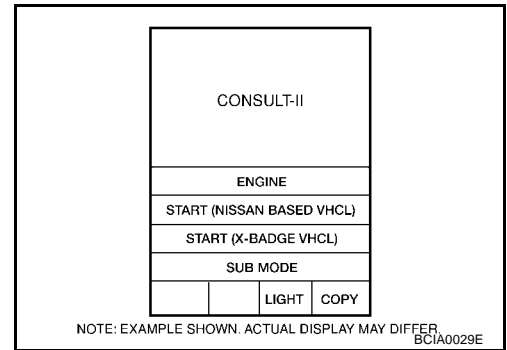

5. Touch "AIR BAG".  
If "AIR BAG" is not indicated, refer to [GI-39, "CONSULT-II Data Link Connector \(DLC\) Circuit"](#).

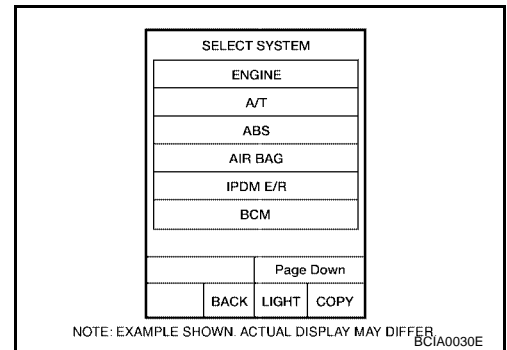

6. Touch "SELF-DIAG [PAST]".

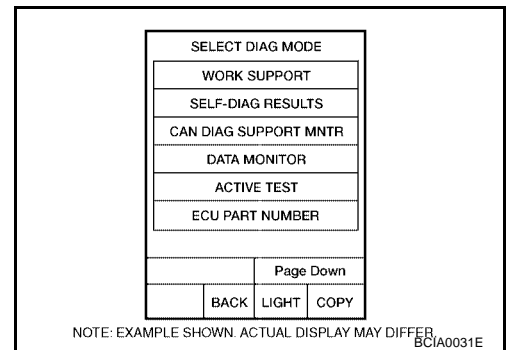

A  
B  
C  
D  
E  
F  
G  
I  
J  
K  
L  
M

SRS

## TROUBLE DIAGNOSIS

7. If diagnostic codes are displayed on "SELF-DIAG [PAST]", go to step 10.

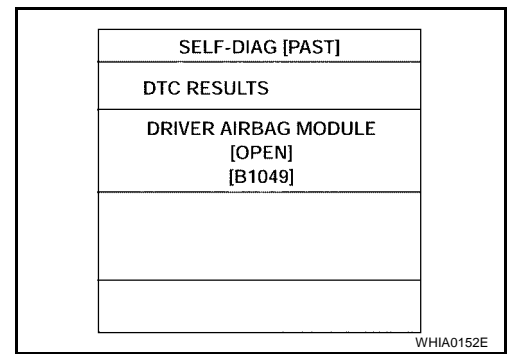

If no malfunction is detected on "SELF-DIAG [PAST]", touch "BACK" and go back to "SELECT DIAG MODE".

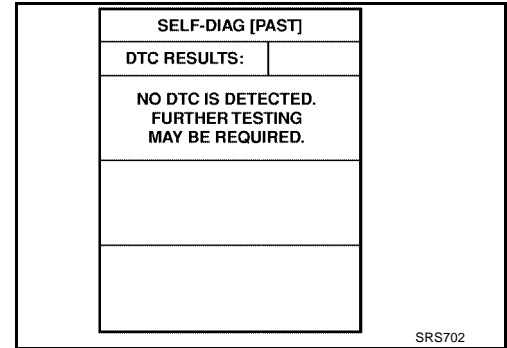

8. Touch "TROUBLE DIAG RECORD".

**NOTE:**

**With "TROUBLE DIAG RECORD", diagnosis results previously erased by a reset operation can be displayed.**

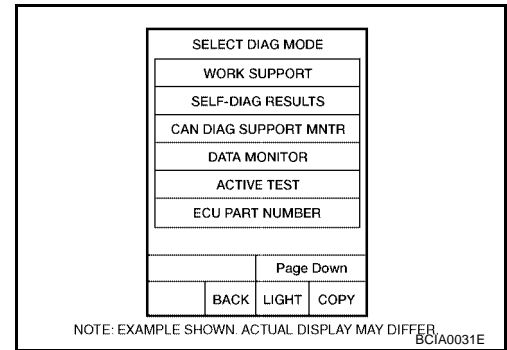

9. Diagnostic code is displayed on "TROUBLE DIAG RECORD".  
10. Touch "PRINT".

11. Compare diagnostic codes to [SRS-27, "Intermittent Malfunction Diagnostic Code Chart \("SELF-DIAG \[PAST\]" or "TROUBLE DIAG RECORD"\)"](#).

12. Touch "BACK" key of CONSULT-II until "SELECT SYSTEM" appears.

13. Turn ignition switch OFF, then turn off and disconnect CONSULT-II, and both battery cables.

14. Repair the system as outlined by the "Repair order" in "Intermittent Malfunction Diagnostic Code Chart", that corresponds to the self-diagnostic result. For replacement procedure of component parts, refer to the Removal and Installation procedure for the appropriate component.

15. Go to [SRS-22, "DIAGNOSTIC PROCEDURE 3"](#), for final checking.

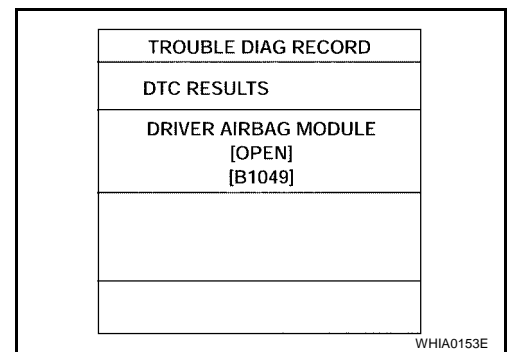

# TROUBLE DIAGNOSIS

## Intermittent Malfunction Diagnostic Code Chart (“SELF-DIAG [PAST]” or “TROUBLE DIAG RECORD”)

Diagnostic item	Explanation	Repair order
NO DTC IS DETECTED.	<ul style="list-style-type: none"> <li>No malfunction is detected.</li> </ul>	<ul style="list-style-type: none"> <li>Go to <a href="#">SRS-22, "DIAGNOSTIC PROCEDURE 3"</a>.</li> </ul>
DRIVER AIR BAG MODULE [OPEN] [B1049]	<ul style="list-style-type: none"> <li>Driver air bag module circuit is open. (including the spiral cable)</li> </ul>	<ol style="list-style-type: none"> <li>Visually check the wiring harness connection.</li> <li>Replace the harness if it has visible damage.</li> <li>If the harness check is OK, replace the spiral cable, diagnosis sensor unit and driver air bag module. (Before disposal, it must be deployed.)</li> </ol>
DRIVER AIR BAG MODULE [VB-SHORT] [B1050]	<ul style="list-style-type: none"> <li>Driver air bag module circuit is shorted to some power supply circuit. (including the spiral cable)</li> </ul>	
DRIVER AIR BAG MODULE [GND-SHORT] [B1051]	<ul style="list-style-type: none"> <li>Driver air bag module circuit is shorted to ground. (including the spiral cable)</li> </ul>	
DRIVER AIR BAG MODULE [SHORT] [B1052]	<ul style="list-style-type: none"> <li>Driver air bag module circuits are shorted to each other.</li> </ul>	
ASSIST A/B MODULE [OPEN] [B1065]	<ul style="list-style-type: none"> <li>Front passenger air bag module circuit is open.</li> </ul>	
ASSIST A/B MODULE [VB-SHORT] [B1066]	<ul style="list-style-type: none"> <li>Front passenger air bag module circuit is shorted to some power supply circuit.</li> </ul>	<ol style="list-style-type: none"> <li>Visually check the wiring harness connection.</li> <li>Replace the harness if it has visible damage.</li> <li>If the harness check is OK, replace the diagnosis sensor unit and front passenger air bag module. (Before disposal, it must be deployed.)</li> </ol>
ASSIST A/B MODULE [GND-SHORT] [B1067]	<ul style="list-style-type: none"> <li>Front passenger air bag module circuit is shorted to ground.</li> </ul>	
ASSIST A/B MODULE [SHORT] [B1068]	<ul style="list-style-type: none"> <li>Front passenger air bag module circuits are shorted to each other.</li> </ul>	
SIDE MODULE LH [OPEN] [B1134]	<ul style="list-style-type: none"> <li>Front LH side air bag module circuit is open.</li> </ul>	
SIDE MODULE LH [VB-SHORT] [B1135]	<ul style="list-style-type: none"> <li>Front LH side air bag module circuit is shorted to some power supply circuits.</li> </ul>	<ol style="list-style-type: none"> <li>Visually check the wiring harness connection.</li> <li>Replace the harness if it has visible damage.</li> <li>If the harness check is OK, replace the diagnosis sensor unit and front LH seat-back assembly. (Before disposal, it must be deployed.)</li> </ol>
SIDE MODULE LH [GND-SHORT] [B1136]	<ul style="list-style-type: none"> <li>Front LH side air bag module circuit is shorted to ground.</li> </ul>	
SIDE MODULE LH [SHORT] [B1137]	<ul style="list-style-type: none"> <li>Front LH side air bag module circuits are shorted to each other.</li> </ul>	
SIDE MODULE RH [OPEN] [B1129]	<ul style="list-style-type: none"> <li>Front RH side air bag module circuit is open.</li> </ul>	
SIDE MODULE RH [VB-SHORT] [B1130]	<ul style="list-style-type: none"> <li>Front RH side air bag module circuit is shorted to some power supply circuits.</li> </ul>	<ol style="list-style-type: none"> <li>Visually check the wiring harness connection.</li> <li>Replace the harness if it has visible damage.</li> <li>If the harness check is OK, replace the diagnosis sensor unit and front RH seat-back assembly. (Before disposal, it must be deployed.)</li> </ol>
SIDE MODULE RH [GND-SHORT] [B1131]	<ul style="list-style-type: none"> <li>Front RH side air bag module circuit is shorted to ground.</li> </ul>	
SIDE MODULE RH [SHORT] [B1132]	<ul style="list-style-type: none"> <li>Front RH side air bag module circuits are shorted to each other.</li> </ul>	

A  
B  
C  
D  
E  
F  
G  
I  
J  
K  
L  
M

**SRS**

## TROUBLE DIAGNOSIS

Diagnostic item	Explanation	Repair order
SATELLITE SENS LH [UNIT FAIL] [B1118] or [B1119] SATELLITE SENS LH [COMM FAIL] [B1120]	<ul style="list-style-type: none"> <li>● LH side air bag (satellite) sensor</li> </ul>	<ol style="list-style-type: none"> <li>1. Visually check the wiring harness connection.</li> <li>2. Replace the harness if it has visible damage.</li> <li>3. If the harness check is OK, replace the diagnosis sensor unit and LH side air bag (satellite) sensor.</li> </ol>
SATELLITE SENS RH [UNIT FAIL] [B1113] or [B1114] SATELLITE SENS RH [COMM FAIL] [B1115]	<ul style="list-style-type: none"> <li>● RH side air bag (satellite) sensor</li> </ul>	<ol style="list-style-type: none"> <li>1. Visually check the wiring harness connection.</li> <li>2. Replace the harness if it has visible damage.</li> <li>3. If the harness check is OK, replace the diagnosis sensor unit and RH side air bag (satellite) sensor.</li> </ol>
PRE-TEN FRONT LH [OPEN] [B1086]	<ul style="list-style-type: none"> <li>● The circuit for front LH pre-tensioner is open to some power supply circuit.</li> </ul>	<ol style="list-style-type: none"> <li>1. Visually check the wiring harness connection.</li> <li>2. Replace the harness if it has visible damage.</li> <li>3. If the harness check is OK, replace the diagnosis sensor unit and front LH seat belt. (Before disposal, it must be deployed.)</li> </ol>
PRE-TEN FRONT LH [VB-SHORT] [B1087]	<ul style="list-style-type: none"> <li>● The circuit for front LH pre-tensioner is shorted to some power supply circuit.</li> </ul>	
PRE-TEN FRONT LH [GND-SHORT] [B1088]	<ul style="list-style-type: none"> <li>● The circuit for front LH pre-tensioner is shorted to ground.</li> </ul>	
PRE-TEN FRONT LH [SHORT] [B1089]	<ul style="list-style-type: none"> <li>● The circuits for the front LH pre-tensioner are shorted to each other.</li> </ul>	
PRE-TEN FRONT RH [OPEN] [B1081]	<ul style="list-style-type: none"> <li>● The circuit for front RH pre-tensioner is open to some power supply circuit.</li> </ul>	
PRE-TEN FRONT RH [VB-SHORT] [B1082]	<ul style="list-style-type: none"> <li>● The circuit for front RH pre-tensioner is shorted to some power supply circuit.</li> </ul>	<ol style="list-style-type: none"> <li>1. Visually check the wiring harness connection.</li> <li>2. Replace the harness if it has visible damage.</li> <li>3. If the harness check is OK, replace the diagnosis sensor unit and front RH seat belt. (Before disposal, it must be deployed.)</li> </ol>
PRE-TEN FRONT RH [GND-SHORT] [B1083]	<ul style="list-style-type: none"> <li>● The circuit for front RH pre-tensioner is shorted to ground.</li> </ul>	
PRE-TEN FRONT RH [SHORT] [B1084]	<ul style="list-style-type: none"> <li>● The circuits for the front RH pre-tensioner are shorted to each other.</li> </ul>	
CONTROL UNIT [B1XXX]	<ul style="list-style-type: none"> <li>● Diagnosis sensor unit is malfunctioning.</li> </ul>	<ol style="list-style-type: none"> <li>1. Visually check the wiring harness connection.</li> <li>2. Replace the harness if it has visible damage.</li> <li>3. If the harness check is OK, replace the diagnosis sensor unit.</li> </ol>

Follow the procedures in numerical order when repairing malfunctioning parts, then make the final system check.

# TROUBLE DIAGNOSIS

EHS000JS

## ⊗ Trouble Diagnoses without CONSULT-II DIAGNOSTIC PROCEDURE 6

Inspecting SRS malfunctioning parts by using "AIR BAG" warning lamp — Diagnosis mode

**NOTE:**

**SRS will not enter Diagnosis mode if no malfunction is detected in User mode.**

1. Turn ignition switch "ON".
2. After "AIR BAG" warning lamp lights for 7 seconds, turn ignition switch "OFF" within 1 second.
3. Wait more than 3 seconds.
4. Repeat steps 1 to 3 three times.
5. Turn ignition switch "ON".  
SRS is now in Diagnosis mode.
6. "AIR BAG" warning lamp operates in Diagnosis mode as follows:

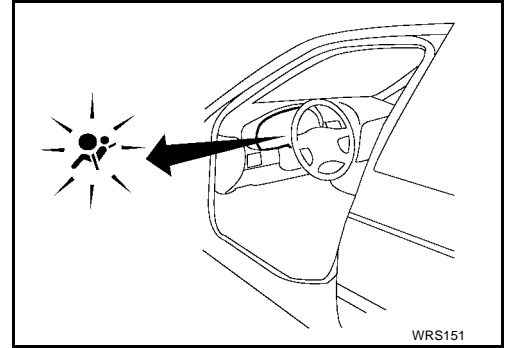

**NOTE:**

If SRS does not enter Diagnosis mode even though malfunction is detected in User mode, check the battery voltage.

If the battery voltage is less than 9V, charge the battery. Then go to [SRS-34, "DIAGNOSTIC PROCEDURE 7"](#)

If the battery voltage is OK, replace the diagnosis sensor unit.

No.	"AIR BAG" warning lamp flash pattern — Diagnosis mode —	SRS condition
1		<p>a through b are repeated.</p> <ul style="list-style-type: none"> <li>● Diagnosis results (previously stored in the memory) might not be erased after repair.</li> <li>● Intermittent malfunction has been detected in the past.</li> </ul> <p>Go to <a href="#">SRS-35, "DIAGNOSTIC PROCEDURE 8 (CONTINUED FROM DIAGNOSTIC PROCEDURE 6)"</a>.</p>

A  
B  
C  
D  
E  
F  
G  
SRS  
I  
J  
K  
L  
M

# TROUBLE DIAGNOSIS

No.	"AIR BAG" warning lamp flash pattern — Diagnosis mode —	SRS condition
2	<p style="text-align: right; font-size: small;">SRS341</p>	<p><b>a</b> through <b>d</b> are repeated.</p> <p><b>b</b> — Driver and front passenger air bag marker (For identifying driver air bag, front passenger air bag and/or seat belt pre-tensioner malfunctioning)</p> <p><b>d</b> — Indicates malfunctioning part. The number of flash varies with malfunctioning part (0.5 sec. ON and 0.5 sec. OFF is counted as one flash.)</p>
3	<p style="text-align: right; font-size: small;">SRS342A</p>	<p><b>a</b> through <b>f</b> are repeated.</p> <p><b>b, c, d</b> — Front side air bag marker (For identifying front side air bag malfunctioning)</p> <p><b>f</b> — Indicates malfunctioning part. The number of flash varies with malfunctioning part (0.5 sec. ON and 0.5 sec. OFF is counted as one flash.)</p>

7. Malfunctioning part is indicated by the number of flashes (part **d** or **f**). Compare the number of flashes to [SRS-30, "Air Bag Warning Lamp Flash Code Chart \(Diagnosis mode\)"](#), and locate malfunctioning part.
8. Turn ignition switch "OFF", and disconnect both battery cables.
9. Repair the system as outlined by the "Repair order" in "Warning Lamp Flash Code Chart" that corresponds to the flash code. For replacement procedure of component parts, refer to the Removal and Installation procedure for the appropriate component.
10. After repairing the system, refer to [SRS-34, "DIAGNOSTIC PROCEDURE 7"](#).

## Air Bag Warning Lamp Flash Code Chart (Diagnosis mode)

<ul style="list-style-type: none"> <li>● Diagnosis results (previously stored in the memory) might not be erased after repair.</li> <li>● Intermittent malfunction has been detected in the past.</li> </ul>	<p>Flash pattern</p> <p style="text-align: right; font-size: small;">SRS333</p>	<p><b>a</b> through <b>b</b> are repeated.</p>
<p>Repair order</p> <ul style="list-style-type: none"> <li>● Go to <a href="#">SRS-35, "DIAGNOSTIC PROCEDURE 8 (CONTINUED FROM DIAGNOSTIC PROCEDURE 6)"</a>.</li> </ul>		

# TROUBLE DIAGNOSIS

<p>The front RH seat belt pre-tensioner circuit is malfunctioning. (<b>d</b> : 1 flash)</p>	<p>Flash pattern</p> <p style="text-align: right;">SRS801</p>	<p><b>a</b> through <b>d</b> are repeated. <b>d</b> — One flash indicates malfunctioning front RH pre-tensioner circuit.</p>	A
	<p>Repair order ("Recheck SRS at each replacement").</p> <ol style="list-style-type: none"> <li>1. Visually check the wiring harness connections.</li> <li>2. Replace the harness if it has visible damage.</li> <li>3. Replace front RH seat belt pre-tensioner. (Before disposing, it must be deployed.)</li> <li>4. Replace the diagnosis sensor unit.</li> <li>5. Replace the related harness.</li> </ol>	B	
<p>The driver air bag module circuit is malfunctioning. (<b>d</b> : 2 flashes)</p>	<p>Flash pattern</p> <p style="text-align: right;">SRS334</p>	<p><b>a</b> through <b>d</b> are repeated. <b>d</b> — Two flashes indicate malfunctioning driver air bag module circuit.</p>	C
	<p>Repair order ("Recheck SRS at each replacement.")</p> <ol style="list-style-type: none"> <li>1. Visually check the wiring harness connection.</li> <li>2. Replace the harness if it has visible damage.</li> <li>3. Replace the spiral cable.</li> <li>4. Replace driver air bag module. (Before disposal, it must be deployed.)</li> <li>5. Replace the diagnosis sensor unit.</li> <li>6. Replace the related harness.</li> </ol>	D	
<p>The front LH seat belt pre-tensioner circuit is malfunctioning. (<b>d</b> : 3 flashes)</p>	<p>Flash pattern</p> <p style="text-align: right;">SRS802</p>	<p><b>a</b> through <b>d</b> are repeated. <b>d</b> — Three flashes indicate malfunctioning front LH pre-tensioner circuit.</p>	E
	<p>Repair order ("Recheck SRS at each replacement").</p> <ol style="list-style-type: none"> <li>1. Visually check the wiring harness connections.</li> <li>2. Replace the harness if it has visible damage.</li> <li>3. Replace front LH seat belt pre-tensioner. (Before disposing, it must be deployed.)</li> <li>4. Replace the diagnosis sensor unit.</li> <li>5. Replace the related harness.</li> </ol>	F	

SRS

# TROUBLE DIAGNOSIS

<p>The diagnosis sensor unit is malfunctioning. (<b>d</b> : 7 flashes)</p>	<p style="text-align: center;">Flash pattern</p> <p style="text-align: right; font-size: small;">SRS335</p>	<p><b>a</b> through <b>d</b> are repeated. <b>d</b> — Seven flashes indicate malfunctioning diagnosis sensor unit.</p>
<p>Repair order ("Recheck SRS at each replacement.")</p> <ol style="list-style-type: none"> <li>1. Visually check the wiring harness connections.</li> <li>2. Replace the harness if it has visible damage.</li> <li>3. Replace the diagnosis sensor unit.</li> <li>4. Replace the related harness.</li> </ol>		
<p>The front passenger air bag module circuit is malfunctioning. (<b>d</b> : 8 flashes)</p>	<p style="text-align: center;">Flash pattern</p> <p style="text-align: right; font-size: small;">SRS336</p>	<p><b>a</b> through <b>d</b> are repeated. <b>d</b> — Eight flashes indicate malfunctioning front passenger air bag module circuit.</p>
<p>Repair order ("Recheck SRS at each replacement.")</p> <ol style="list-style-type: none"> <li>1. Visually check the wiring harness connection.</li> <li>2. Replace the harness if it has visible damage.</li> <li>3. Replace front passenger air bag module. (Before disposal, it must be deployed.)</li> <li>4. Replace the diagnosis sensor unit.</li> <li>5. Replace the related harness.</li> </ol>		
<p>The front RH side air bag module circuit is malfunctioning. (<b>f</b> : 1 flash)</p>	<p style="text-align: center;">Flash pattern</p> <p style="text-align: right; font-size: small;">SRS338</p>	<p><b>a</b> through <b>f</b> are repeated. <b>f</b> — One flash indicates malfunctioning front RH side air bag module circuit.</p>
<p>Repair order ("Recheck SRS at each replacement.")</p> <ol style="list-style-type: none"> <li>1. Visually check the wiring harness connection.</li> <li>2. Replace the harness if it has visible damage.</li> <li>3. Replace front RH seatback assembly. (Before disposal, the front RH side air bag module must be deployed.)</li> <li>4. Replace the diagnosis sensor unit.</li> <li>5. Replace the related harness.</li> </ol>		

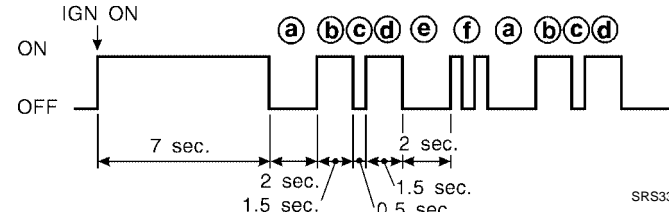
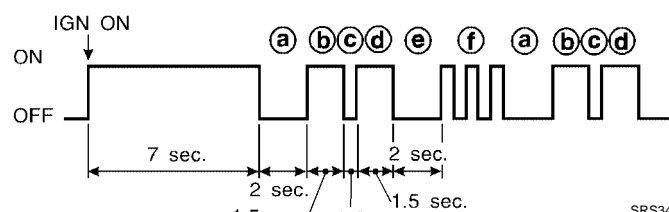
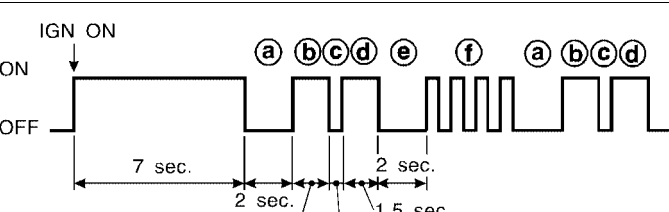

# TROUBLE DIAGNOSIS

<p>The front LH side air bag module circuit is malfunctioning. (f : 2 flashes)</p>	<p style="text-align: center;">Flash pattern</p>  <p>a through f are repeated. f — Two flashes indicate malfunctioning front LH side air bag module circuit.</p> <p>Repair order ("Recheck SRS at each replacement.")</p> <ol style="list-style-type: none"> <li>1. Visually check the wiring harness connection.</li> <li>2. Replace the harness if it has visible damage.</li> <li>3. Replace front LH seatback assembly. (Before disposal, the front LH side air bag module must be deployed.)</li> <li>4. Replace the diagnosis sensor unit.</li> <li>5. Replace the related harness.</li> </ol>	<p>A</p> <p>B</p> <p>C</p> <p>D</p> <p>E</p>
<p>The RH side air bag (satellite) sensor is malfunctioning. (f : 3 flashes)</p>	<p style="text-align: center;">Flash pattern</p>  <p>a through f are repeated. f — Three flashes indicate malfunctioning RH side air bag (satellite) sensor circuit.</p> <p>Repair order ("Recheck SRS at each replacement.")</p> <ol style="list-style-type: none"> <li>1. Visually check the wiring harness connection.</li> <li>2. Replace the harness if it has visible damage.</li> <li>3. Replace the RH side air bag (satellite) sensor.</li> <li>4. Replace the diagnosis sensor unit.</li> <li>5. Replace the related harness.</li> </ol>	<p>F</p> <p>G</p> <p style="background-color: black; color: white; text-align: center; padding: 2px;">SRS</p> <p>I</p> <p>J</p>
<p>The LH side air bag (satellite) sensor is malfunctioning. (f : 4 flashes)</p>	<p style="text-align: center;">Flash pattern</p>  <p>a through f are repeated. f — Four flashes indicate malfunctioning LH side air bag (satellite) sensor circuit.</p> <p>Repair order ("Recheck SRS at each replacement.")</p> <ol style="list-style-type: none"> <li>1. Visually check the wiring harness connection.</li> <li>2. Replace the harness if it has visible damage.</li> <li>3. Replace the LH side air bag (satellite) sensor.</li> <li>4. Replace the diagnosis sensor unit.</li> <li>5. Replace the related harness.</li> </ol>	<p>K</p> <p>L</p> <p>M</p>

Follow the procedures in numerical order when repairing malfunctioning parts. Confirm whether malfunction is eliminated using the air bag warning lamp or CONSULT-II each time repair is finished. If malfunction is still observed, proceed to the next step. When malfunction is eliminated, further repair work is not required.

# TROUBLE DIAGNOSIS

## DIAGNOSTIC PROCEDURE 7

### Final checking after repairing SRS by using "AIR BAG" warning lamp — Diagnosis mode and User mode

1. After repairing SRS, connect both battery cables.
2. Open driver's door.
3. Turn ignition switch "ON".
4. "AIR BAG" warning lamp operates in Diagnosis mode as follows:

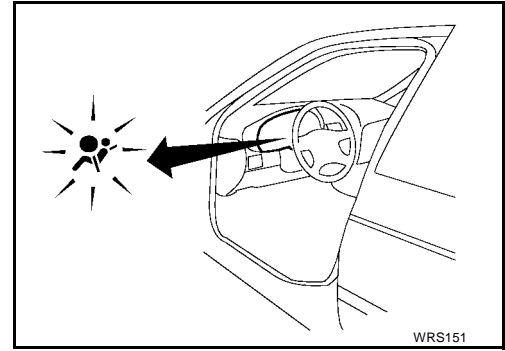

No.	"AIR BAG" warning lamp flash pattern — Diagnosis mode —	SRS condition
1		<p><b>a</b> through <b>b</b> are repeated.</p> <p>No malfunction is detected or repair is completed. No further action is necessary.</p>
2		<p><b>a</b> through <b>d</b> are repeated.</p> <p><b>b</b> — Driver and front passenger air bag marker (For identifying driver air bag, front passenger air bag and/or seat belt pre-tensioner malfunctioning)</p> <p><b>d</b> — Indicates malfunctioning part. The number of flashes varies with malfunctioning part (0.5 sec. ON and 0.5 sec. OFF is counted as one flash.)</p> <p>The system is malfunctioning and needs to be repaired.</p>
3		<p><b>a</b> through <b>f</b> are repeated.</p> <p><b>b, c, d</b> — Front side air bag marker (For identifying front side air bag malfunctioning)</p> <p><b>f</b> — Indicates malfunctioning part. The number of flashes varies with malfunctioning part (0.5 sec. ON and 0.5 sec. OFF is counted as one flash.)</p>

#### NOTE:

When diagnosis sensor unit is replaced with new one, "AIR BAG" warning lamp will operate in User mode. Checking "AIR BAG" warning lamp operation in Diagnosis mode is not required. Go to step 6.

5. If "AIR BAG" warning lamp operates as shown in No. 1 in chart above, turn ignition switch "OFF" to reset from Diagnosis mode to User mode and to erase the memory of the malfunction. Then go to step 6.  
If "AIR BAG" warning lamp operates as shown in No. 2 or No. 3 in chart above, the malfunctioning part is not repaired completely, or another malfunctioning part is detected. Go to [SRS-29, "DIAGNOSTIC PROCEDURE 6"](#), and repair malfunctioning part completely.
6. Turn ignition switch "ON". "AIR BAG" warning lamp operates in User mode. Compare "AIR BAG" warning lamp operation to the chart below.



#### NOTE:

If switching Diagnosis mode to User mode is required while malfunction is being detected, turn ignition switch as follows:

7. Turn ignition switch "ON".
8. After "AIR BAG" warning lamp lights for 7 seconds, turn ignition switch "OFF".

# TROUBLE DIAGNOSIS

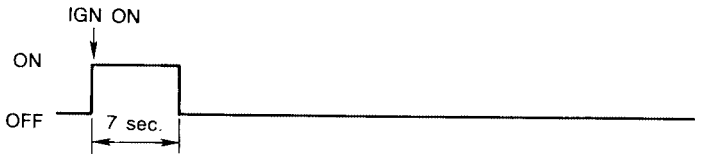
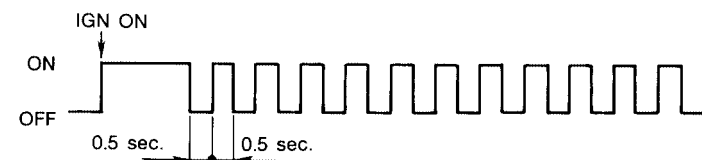
9. Wait more than 3 seconds.
  10. Repeat steps 1 to 3 three times.
  11. Turn ignition switch "ON".
- SRS is now in User mode.

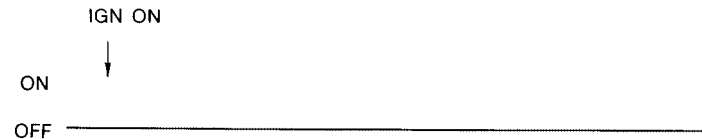
"AIR BAG" warning lamp operation — User mode —	SRS condition	Reference item
 <p style="text-align: right; font-size: small;">MRS095A</p>	<p>No malfunction is detected. No further action is necessary.</p>	<p>—</p>
 <p style="text-align: right; font-size: small;">MRS096A</p>	<p>The system is malfunctioning and needs to be repaired as indicated.</p>	<p>Go to <a href="#">SRS-29, "DIAGNOSTIC PROCEDURE 6"</a>.</p>
 <p style="text-align: right; font-size: small;">MRS097A</p>	<p>Air bag is deployed.</p> <p>Air bag fuse, diagnosis sensor unit or harness is malfunctioning and needs to be repaired.</p>	<p>Go to <a href="#">SRS-47, "COLLISION DIAGNOSIS"</a>.</p> <p>Go to <a href="#">SRS-36, "DIAGNOSTIC PROCEDURE 9"</a>.</p>
 <p style="text-align: right; font-size: small;">MRS098A</p>	<p>One of the following has occurred and needs to be repaired.</p> <ul style="list-style-type: none"> <li>● Meter fuse is blown.</li> <li>● "AIR BAG" warning lamp circuit has open or short.</li> <li>● Diagnosis sensor unit is malfunctioning.</li> </ul>	<p>Go to <a href="#">SRS-37, "DIAGNOSTIC PROCEDURE 10"</a>.</p>

## DIAGNOSTIC PROCEDURE 8 (CONTINUED FROM DIAGNOSTIC PROCEDURE 6) Inspecting SRS malfunctioning record

### 1. CONSIDER POSSIBILITY OF NOT ERASING SELF-DIAGNOSTIC RESULT AFTER REPAIRING

Is it the first time for maintenance of SRS?

Yes or No

- Yes >> Go to [SRS-25, "DIAGNOSTIC PROCEDURE 5"](#). (Further inspection cannot be performed without CONSULT-II.)
- No >> Diagnosis results (previously stored in the memory) might not be erased after repair. Go to [SRS-34, "DIAGNOSTIC PROCEDURE 7"](#).

# TROUBLE DIAGNOSIS

EHS000JT

## Trouble Diagnoses: "AIR BAG" Warning Lamp Does Not Turn Off DIAGNOSTIC PROCEDURE 9

### 1. SEE THE DEPLOYMENT OF AIR BAG MODULE

Is air bag module deployed?

Yes or No

- Yes >> Refer to [SRS-47, "COLLISION DIAGNOSIS"](#).
- No >> GO TO 2.

### 2. CHECK AIR BAG FUSE

Check 10A fuse 18 [located in the fuse block (J/B)].

OK or NG

- OK >> GO TO 4.
- NG >> GO TO 3.

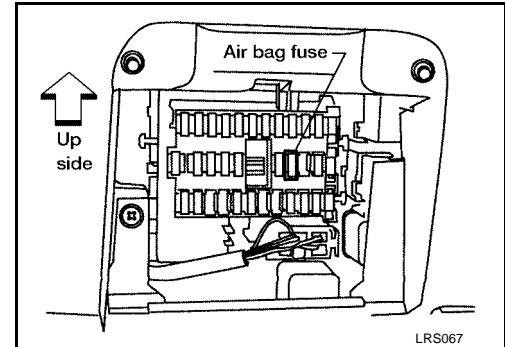

### 3. CHECK AIR BAG FUSE AGAIN

Replace "AIR BAG" fuse and turn ignition switch ON.

Is "AIR BAG" fuse blown again?

- Yes >> Repair main harness and/or replace related harness.
- No >> Inspection End.

### 4. CHECK DIAGNOSIS SENSOR UNIT



Connect CONSULT-II and touch "START".

Is "AIR BAG" displayed on CONSULT-II?

Yes or No

- Yes >> GO TO 5.
- No >> Visually check the wiring harness connection of diagnosis sensor unit. If the harness connection check result is OK, replace diagnosis sensor unit. Refer to [SRS-38, "Removal and Installation"](#).

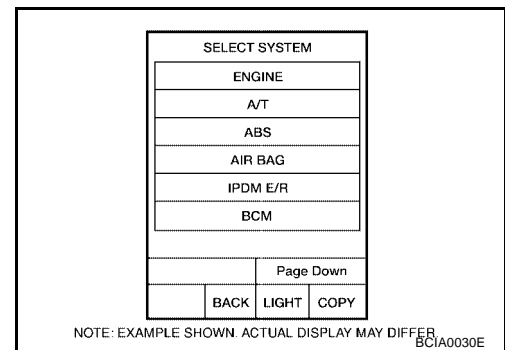

### 5. CHECK HARNESS CONNECTION

Is harness connection between warning lamp and diagnosis sensor unit OK?

OK or NG

- OK >> Replace diagnosis sensor unit. Refer to [SRS-38, "Removal and Installation"](#).
- NG >> Connect "AIR BAG" warning lamp and diagnosis sensor unit connector properly. If "AIR BAG" warning lamp still does not go off, replace harness.

# TROUBLE DIAGNOSIS

## Trouble Diagnoses: "AIR BAG" Warning Lamp Does Not Turn On DIAGNOSTIC PROCEDURE 10

EHS000JU

### 1. CHECK "METER" FUSE

Check 10A fuse 30 [located in the fuse block (J/B)].

OK or NG

OK >> GO TO 3.

NG >> GO TO 2.

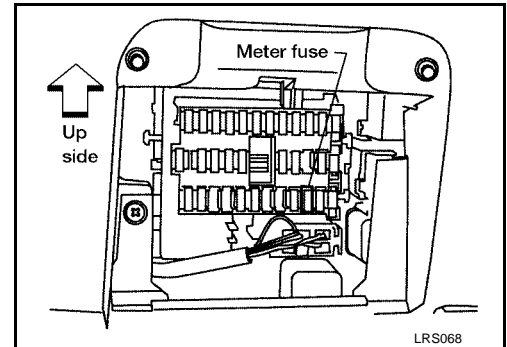

### 2. CHECK "METER" FUSE AGAIN

Replace "METER" fuse and turn ignition switch ON.

Is "METER" fuse blown again?

Yes >> Repair main harness.

No >> Inspection End.

### 3. CHECK HARNESS CONNECTION BETWEEN DIAGNOSIS SENSOR UNIT AND "AIR BAG" WARNING LAMP

Disconnect diagnosis sensor unit connector and turn ignition switch "ON".

Does "AIR BAG" warning lamp turn on?

Yes or No

Yes >> Replace diagnosis sensor unit. Refer to [SRS-38. "Removal and Installation"](#).

No >> Check the ground circuit of "AIR BAG" warning lamp.

A

B

C

D

E

F

G

SRS

I

J

K

L

M

# DIAGNOSIS SENSOR UNIT

PFP:28556

EHS000JV

## DIAGNOSIS SENSOR UNIT

### Removal and Installation REMOVAL

#### CAUTION:

- Before servicing SRS, turn the ignition switch off, disconnect both battery cables and wait for at least 3 minutes.
  - Do not use old bolts after removal; replace with new ones.
  - Check diagnosis sensor unit for proper installation.
  - Check diagnosis sensor unit to ensure it is free of deformities, dents, cracks or rust. If they show any visible signs of damage, replace them with new ones.
  - Check diagnosis sensor unit brackets to ensure they are free of deformities or rust.
  - Replace diagnosis sensor unit if it has been dropped or sustained an impact.
  - After replacement of diagnosis sensor unit, perform self-diagnosis for SRS. Refer to [SRS-18, "SRS Operation Check"](#) for details.
1. Disconnect driver, front passenger and front side air bag module connectors. Also, disconnect front seat belt pre-tensioner connectors.
  2. Remove console box. Refer to [IP-10, "INSTRUMENT PANEL ASSEMBLY"](#).
  3. Disconnect diagnosis sensor unit connector.
  4. Remove bolts from diagnosis sensor unit.  
Then remove the diagnosis sensor unit.

### INSTALLATION

#### NOTE:

- To install, reverse the removal procedure sequence.

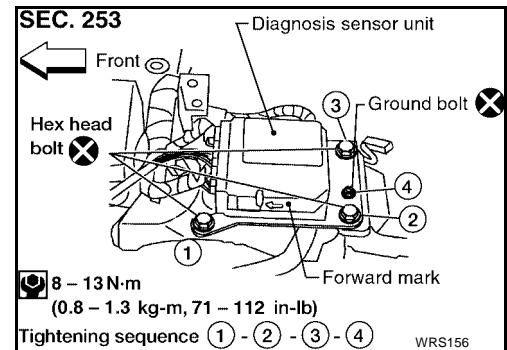

# FRONT SEAT BELT PRE-TENSIONER

---

## FRONT SEAT BELT PRE-TENSIONER

PFP:86884

### Removal and Installation

EHS000JW

For removal and installation of front seat belt pre-tensioners, refer to [SB-3, "Removal and Installation"](#) .

A

B

C

D

E

F

G

SRS

I

J

K

L

M

# SIDE AIR BAG (SATELLITE) SENSOR

PFP:K8EH0

## SIDE AIR BAG (SATELLITE) SENSOR

EHS000JX

### Removal and Installation

#### REMOVAL

#### CAUTION:

- Before servicing SRS, turn the ignition switch off, disconnect both battery cables and wait at least 3 minutes.
  - Do not use old nut or bolt coated with bonding agent after removal; replace with new ones.
  - Check side air bag (satellite) sensor to ensure they are free of deformities, dents, cracks or rust. If it shows any visible signs of damage, replace it with new one.
  - Do not attempt to disassemble side air bag (satellite) sensor.
  - Replace side air bag (satellite) sensor if it has been dropped or sustained an impact.
1. Remove front seat belt pre-tensioner. Refer to [SB-3, "Removal and Installation"](#).
  2. Disconnect side air bag (satellite) sensor connector.
  3. Remove bolt and nut from side air bag (satellite) sensor unit. Then remove the side air bag (satellite) sensor.

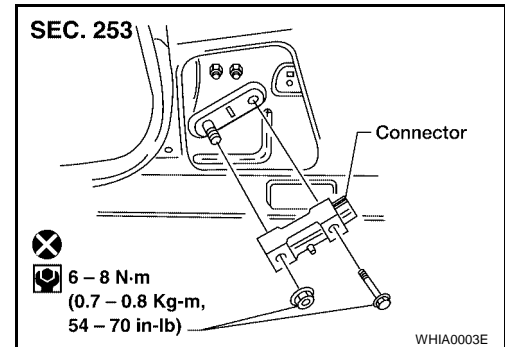

#### INSTALLATION

#### CAUTION:

- Check side air bag (satellite) sensor for proper installation.
- After replacement of side air bag (satellite) sensor, check SRS function and perform self-diagnosis. Refer to [SRS-18, "SRS Operation Check"](#) for details.

To install, reverse the removal procedure sequence.



# DRIVER AIR BAG MODULE

## DRIVER AIR BAG MODULE

PFK:K8510

### Removal and Installation

EHS000JY

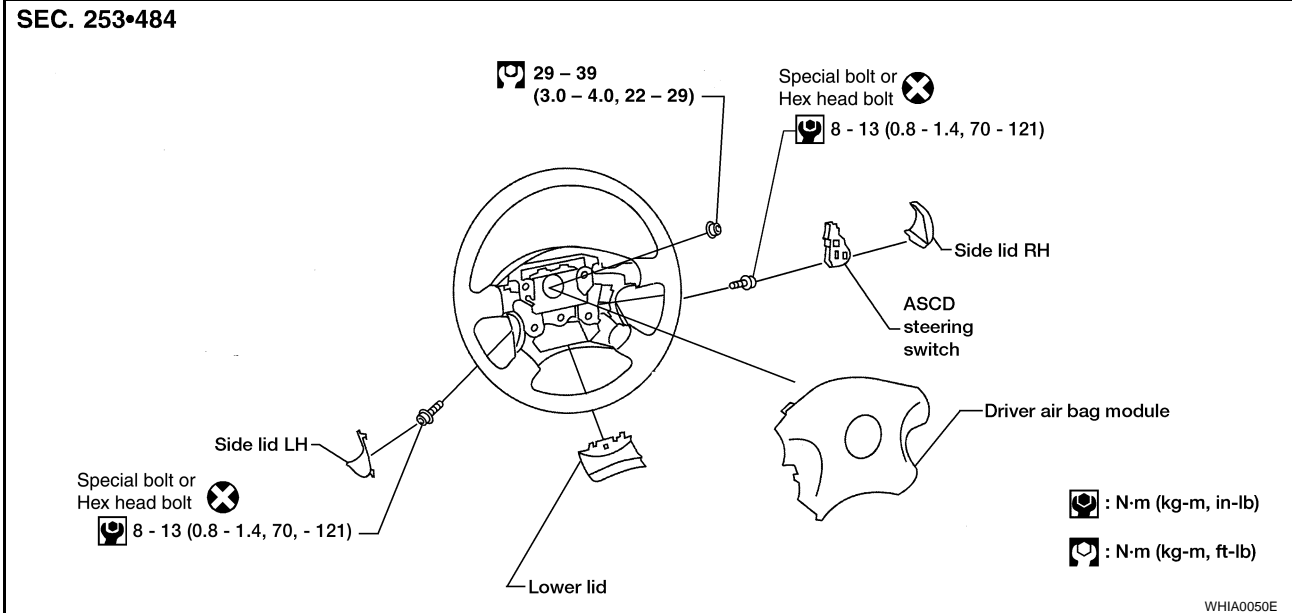

### Removal

EHS000JZ

#### CAUTION:

- Do not attempt to repair or replace damaged direct-connect driver air bag module connectors. If a direct-connect harness connector is damaged, the harness must be replaced.
  - Before servicing SRS, turn the ignition switch off, disconnect both battery cables and wait at least 3 minutes.
  - Always work from the side of driver air bag module.
1. Remove side lids and ASCD steering switch (if equipped). Using the TAMPER RESISTANT TORX (Size T30) (if equipped), remove left and right special bolts or hex head bolts. Driver air bag module can then be removed.
  2. Disconnect the air bag harness connector and remove the air bag module.
    - For removal/installation of the direct-connect SRS connectors, refer to [SRS-6, "Direct-connect SRS Component Connectors"](#).

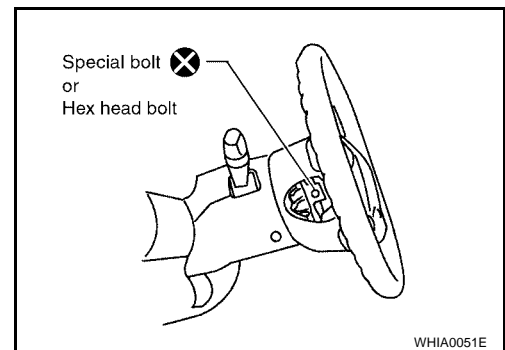

#### CAUTION:

- Always place driver air bag module with pad side facing upward.
- Do not attempt to disassemble air bag module.
- The bolts are coated with bonding agent. Do not use old bolts after removal; replace with new ones.
- Do not insert any foreign objects (screwdriver, etc.) into air bag module connector.

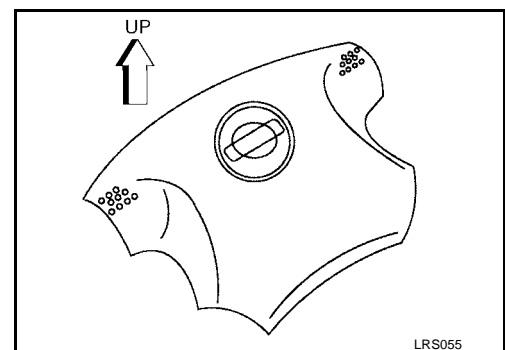

# DRIVER AIR BAG MODULE

- Replace driver air bag module if it has been dropped or sustained an impact.
- Do not expose the driver air bag module to temperatures exceeding 90°C (194°F).
- Do not allow oil, grease or water to come in contact with the driver air bag module.

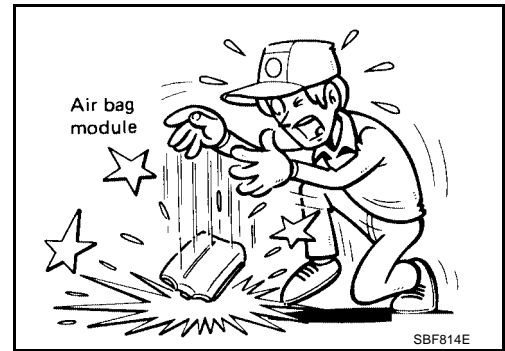

EHS000K0

## Installation

1. Connect driver air bag harness connector.
  - For removal/installation of the direct-connect SRS connectors, refer to [SRS-6, "Direct-connect SRS Component Connectors"](#).
2. Position driver air bag module, press firmly and tighten with new special bolts.
3. Install ASCD steering switch (if equipped) and all lids.
4. Connect both battery cables, then conduct self-diagnosis to ensure entire SRS operates properly. (Use CONSULT-II or warning lamp check.)
5. Turn steering wheel to the left end and then to the right end fully to make sure that spiral cable is set in the neutral position.

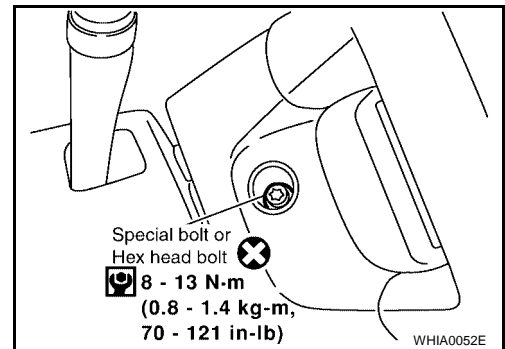

If air bag warning lamp blinks or stays ON (at the user mode), it shows the spiral cable may be snapped due to its improper position. Perform self-diagnosis again (use CONSULT-II or warning lamp). Refer to [SRS-18, "SRS Operation Check"](#). If a malfunction is detected, replace the spiral cable with a new one.

6. Perform self-diagnosis again to check that no malfunction is detected. Go to [SRS-18, "SRS Operation Check"](#) and perform self-diagnosis to ensure entire SRS operates properly. (Use CONSULT-II or warning lamp check.)

# SPIRAL CABLE

PFP:25554

## SPIRAL CABLE

### Removal and Installation

EHS000K1

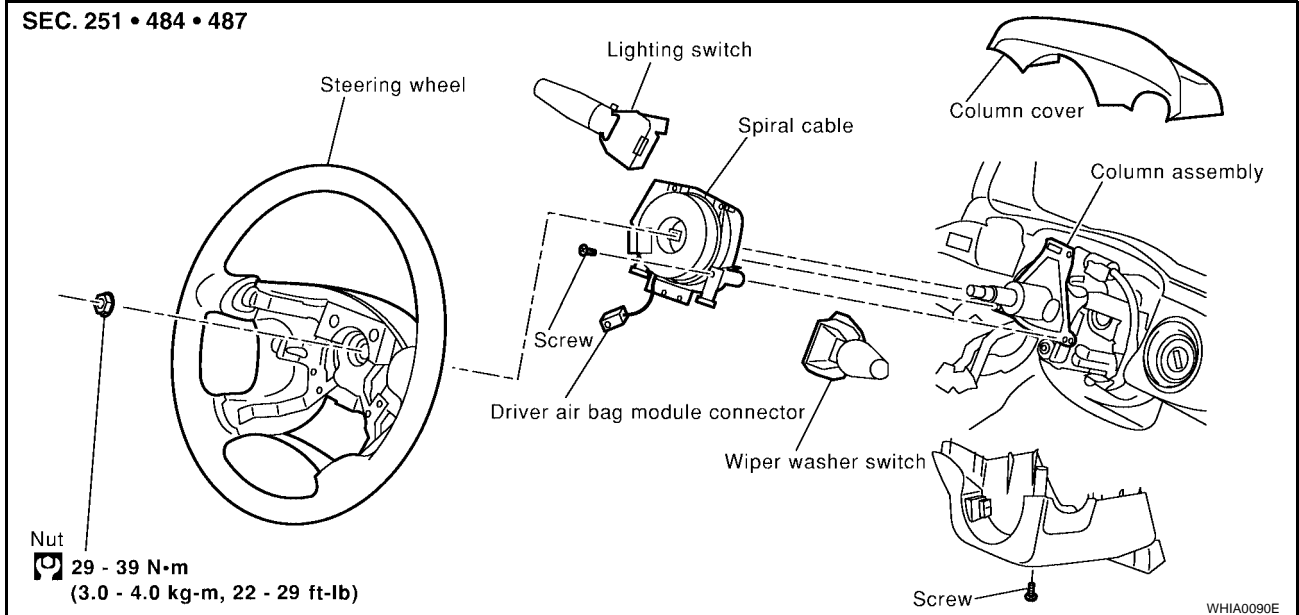

### Removal

EHS000K2

#### CAUTION:

- Before servicing SRS, turn the ignition switch off, disconnect both battery cables and wait at least 3 minutes.

1. Remove driver air bag module. Refer to [SRS-41, "Removal"](#).
2. Set steering wheel in the neutral position.
3. Remove lower lid and disconnect horn connector. Remove steering wheel nut.
4. Using steering wheel puller, remove steering wheel. Be careful not to over-tighten puller bolt on steering wheel.

#### CAUTION:

- Do not tap or bump the steering wheel.
5. Remove steering column cover.

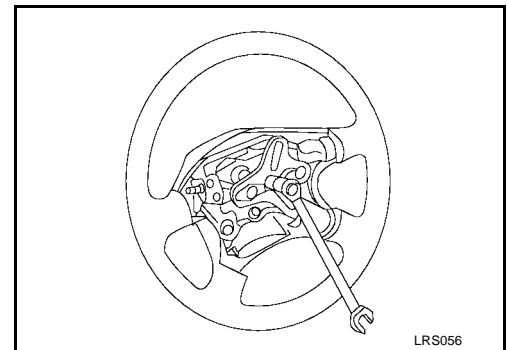

6. Unlock the spiral cable connector. Then disconnect connectors and remove the four screws. The spiral cable can then be removed.

#### CAUTION:

- Do not attempt to disassemble spiral cable.
- Do not apply lubricant to the spiral cable.

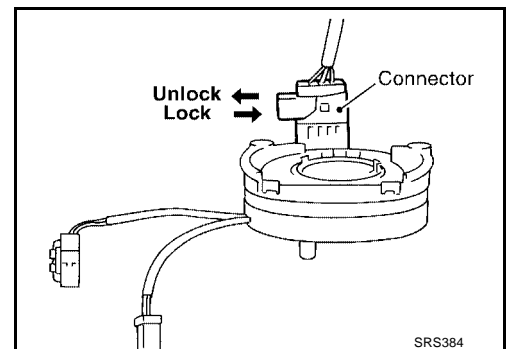

A  
B  
C  
D  
E  
F  
G

SRS

I  
J  
K  
L  
M

# SPIRAL CABLE

EHS000K3

## Installation

1. Set the front wheels in the straight-ahead position.
2. Make sure that the spiral cable is in the neutral position. The neutral position is detected by turning left about 3.5 revolutions from the right end position. Align the two marks (▲).

### CAUTION:

- The spiral cable may snap due to steering operation if the cable is installed in an improper position.
  - Also, with the steering linkage disconnected, the cable may snap by turning the steering wheel beyond the limited number of turns. To set spiral cable to neutral position turn to the left approximately 3.5 turns from the right end position.
3. Connect spiral cable connector and tighten with screws. Install steering column cover.
  4. Install steering wheel, aligning with spiral cable pin guides, and pull spiral cable through.
  5. Connect horn connector and engage spiral cable with pawls in steering wheel. Move driver air bag module connector away from steering wheel lower lid opening.
  6. Tighten nut.

 : 29 - 39 N-m (3.0 - 4.0 kg-m, 22 - 29 ft-lb)

7. Install driver air bag module. Refer to [SRS-42, "Installation"](#).
8. Connect both battery cables, then conduct self-diagnosis to ensure entire SRS operates properly. Refer to [SRS-18, "SRS Operation Check"](#).

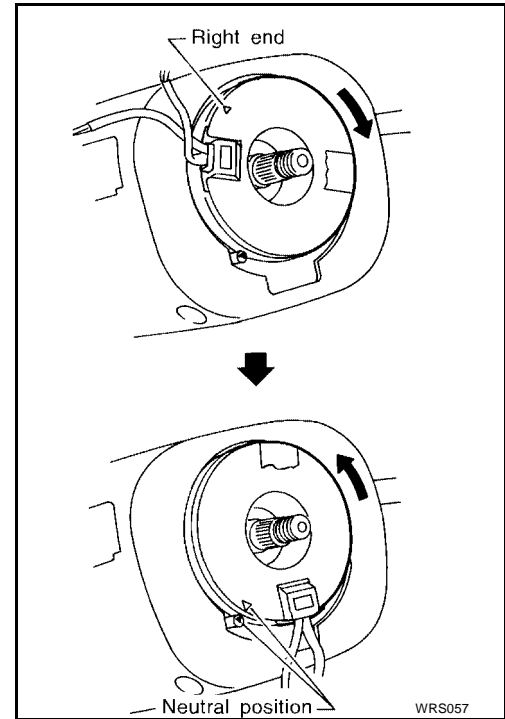

# FRONT PASSENGER AIR BAG MODULE

PF:K8515

EHS000K4

## FRONT PASSENGER AIR BAG MODULE

### Removal and Installation REMOVAL

#### CAUTION:

- Do not attempt to repair or replace damaged direct-connect front passenger air bag module connectors. If a direct-connect harness connector is damaged, the harness must be replaced.
  - Before servicing SRS, turn the ignition switch off, disconnect both battery cables and wait for at least 3 minutes.
  - Always work from the side of or under air bag module.
1. Remove glove box assembly. Refer to [IP-10, "INSTRUMENT PANEL ASSEMBLY"](#) for details.
  2. Disconnect front passenger air bag module connector from air bag harness connector.
  3. Remove the nuts and hex bolts from front passenger air bag module.
  4. Remove the front passenger air bag module from the instrument panel.
- The front passenger air bag module is heavy and should be supported using both hands during removal.

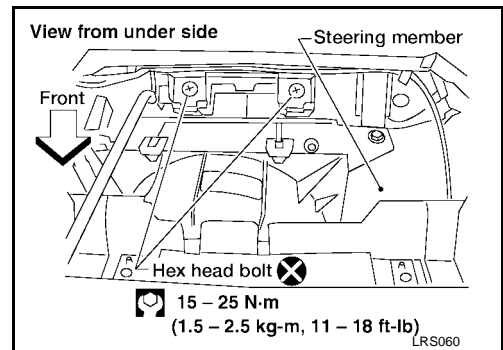
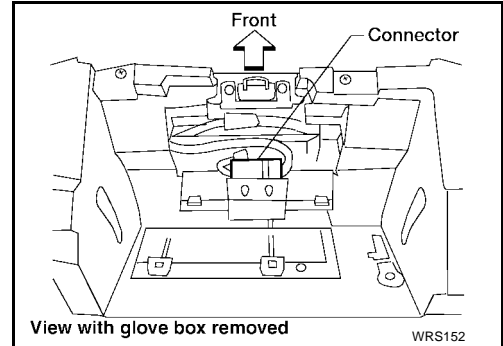

#### CAUTION:

- Always place front passenger air bag module with pad side facing upward.
- Do not attempt to disassemble air bag module.
- The special bolts are coated with bonding agent. Do not use old bolts after removal; replace with new coated bolts.
- Do not insert any foreign objects (screwdriver, etc.) into air bag module connector.

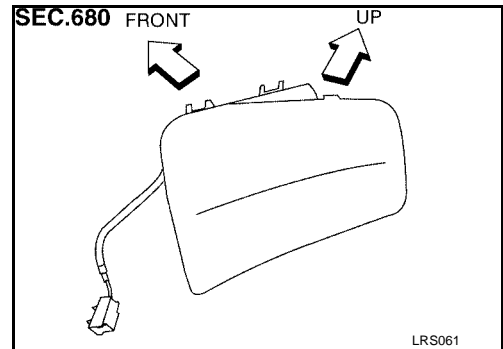

- Replace air bag module if it has been dropped or sustained an impact.
- Do not expose the air bag module to temperatures exceeding 90°C (194°F).
- Do not allow oil, grease or water to come in contact with the front passenger air bag module.
- After air bag inflates, the front instrument panel assembly should be replaced if damaged.



A  
B  
C  
D  
E  
F  
G  
SRS  
I  
J  
K  
L  
M

# FRONT PASSENGER AIR BAG MODULE

## INSTALLATION

### CAUTION:

- **Always work from the side of or under air bag module.**
1. Install front passenger air bag module on steering member.
    - Ensure harness is not caught between rear of air bag module and steering member.
  2. Install glove box assembly. (Glove box lid is open.)

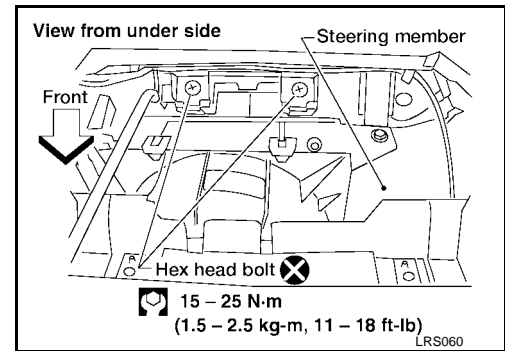

3. Connect front passenger air bag module connector to air bag harness connector.
4. Close the glove box lid.
5. Connect both battery cables.
6. Go to [SRS-18, "SRS Operation Check"](#) and perform self-diagnosis to ensure entire SRS operates properly. (Use CONSULT-II or warning lamp check.)

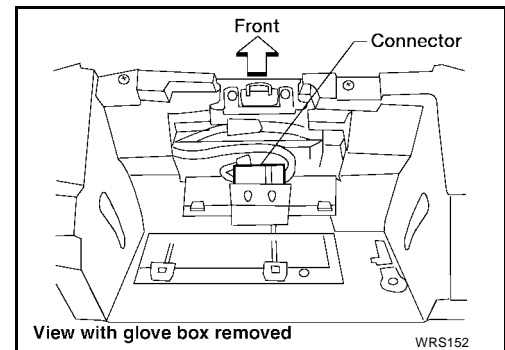

# COLLISION DIAGNOSIS

PFP:00015

## COLLISION DIAGNOSIS

### For Frontal Collision

EHS001MU

Check the SRS components using the following table.

- After the work is completed, perform self-diagnosis to check that no malfunction is detected. Refer to [SRS-18, "SRS Operation Check"](#).

### SRS INSPECTION (FOR FRONTAL COLLISION)

Part	SRS is activated	SRS is NOT activated
Driver air bag module	If the driver air bag has deployed: <b>REPLACE</b> Install with new fasteners.	If the driver air bag has NOT been activated: 1. Remove driver air bag module. Check harness cover and connectors for damage, terminals for deformities, and harness for binding. 2. Install driver air bag module into the steering wheel to check fit and alignment with the wheel. 3. If no damage is found, reinstall with new fasteners. 4. If damaged— <b>REPLACE</b> . Install driver air bag modules with new fasteners.
Front passenger air bag module	If the front passenger air bag has deployed: <b>REPLACE</b> Install with new fasteners.	If the front passenger air bag has NOT been activated: 1. Remove front passenger air bag module. Check harness cover and connectors for damage, terminals for deformities, and harness for binding. 2. Install front passenger air bag module into the instrument panel to check fit with the instrument panel. 3. If no damage is found, reinstall with new fasteners. 4. If damaged— <b>REPLACE</b> . Install front passenger air bag modules with new fasteners.
Crash zone sensor	If any of the front air bags or seat belt pre-tensioners* have been activated: <b>REPLACE</b> the crash zone sensor and bracket with new fasteners.  *: Confirm seat belt pre-tensioner activation using CONSULT-II only.	If the front air bags or seat belt pre-tensioners have NOT been activated: 1. Remove the crash zone sensor. Check harness connectors for damage, terminals for deformities, and harness for binding. 2. Check for visible signs of damage (dents, cracks, deformation) of the crash zone sensor and bracket. 3. Install the crash zone sensor to check fit. 4. If no damage is found, reinstall with new fasteners. 5. If damaged— <b>REPLACE</b> the crash zone sensor and bracket with new fasteners.
Seat belt pre-tensioner assemblies (All applicable locations: buckle, reel, lap outer)	If either the driver or passenger seat belt pre-tensioner* has been activated: <b>REPLACE</b> all seat belt pre-tensioner assemblies with new fasteners.  *: Confirm seat belt pre-tensioner activation using CONSULT-II only.	If the pre-tensioners have NOT been activated: 1. Remove seat belt pre-tensioners. Check harness cover and connectors for damage, terminals for deformities, and harness for binding. 2. Check belts for damage and anchors for loose mounting. 3. Check retractor for smooth operation. 4. Check seat belt adjuster for damage. 5. Check for deformities of the center pillar inner. 6. If the center pillar inner has no damage, <b>REPLACE</b> the seat belt pre-tensioner assembly. 7. If no damage is found, reinstall seat belt pre-tensioner assembly. 8. If damaged— <b>REPLACE</b> . Install the seat belt pre-tensioners with new fasteners.
Diagnosis sensor unit	If any of the SRS components have been activated: <b>REPLACE</b> the diagnosis sensor unit. Install with new fasteners.	If none of the SRS components have been activated: 1. Check case for dents, cracks or deformities. 2. Check connectors for damage, and terminals for deformities. 3. If no damage is found, reinstall with new fasteners. 4. If damaged— <b>REPLACE</b> . Install diagnosis sensor unit with new fasteners.

# COLLISION DIAGNOSIS

Part	SRS is activated	SRS is NOT activated
Steering wheel	<ol style="list-style-type: none"> <li>1. Visually check steering wheel for deformities.</li> <li>2. Check harness (built into steering wheel) and connectors for damage, and terminals for deformities.</li> <li>3. Install driver air bag module into the steering wheel to check fit and alignment with the wheel.</li> <li>4. Check steering wheel for excessive free play.</li> <li>5. If no damage is found, reinstall.</li> <li>6. If damaged—REPLACE.</li> </ol>	
Spiral cable	If the driver front air bag has deployed: REPLACE the spiral cable.	If the driver front air bag has not deployed: <ol style="list-style-type: none"> <li>1. Visually check spiral cable and combination switch for damage.</li> <li>2. Check connectors and protective tape for damage.</li> <li>3. Check steering wheel for noise, binding or heavy operation.</li> <li>4. If no damage is found, reinstall.</li> <li>5. If damaged—REPLACE.</li> </ol>
Occupant classification system (Passenger seat)	<ol style="list-style-type: none"> <li>1. Remove passenger seat.</li> <li>2. Check control unit case for dents, cracks or deformities.</li> <li>3. Check connectors and pressure sensor tube for damage, and terminals for deformities.</li> <li>4. Check seat frame and cushion pan for dents or deformities.</li> <li>5. If no damage is found, reinstall seat with new fasteners.</li> <li>6. If damaged — REPLACE seat cushion assembly with new fasteners.</li> </ol>	
Harness and connectors	<ol style="list-style-type: none"> <li>1. Check connectors for poor connection, damage, and terminals for deformities.</li> <li>2. Check harness for binding, chafing, cuts, or deformities.</li> <li>3. If no damage is found, reinstall the harness and connectors.</li> <li>4. If damaged—REPLACE the damaged harness. Do not attempt to repair, splice or modify any SRS harness.</li> </ol>	
Instrument panel	If the passenger front air bag has deployed: REPLACE the instrument panel assembly.	If the passenger front air bag has NOT deployed: <ol style="list-style-type: none"> <li>1. Visually check instrument panel for damage.</li> <li>2. If no damage is found, reinstall the instrument panel.</li> <li>3. If damaged—REPLACE the instrument panel.</li> </ol>

## For Side and Rollover Collision

*EHS001MV*

Check the SRS components using the following table.

- After the work is completed, perform self-diagnosis to check that no malfunction is detected. Refer to [SRS-18, "SRS Operation Check"](#).

### WHEN SRS IS ACTIVATED IN THE SIDE OR ROLLOVER COLLISION

1. Replace the following components:
  - Front seat back assembly (on the side on which side air bag is activated)
  - Diagnosis sensor unit
  - (LH or RH) side air bag (satellite) sensor (on the side on which side air bag is activated)
2. Check the SRS components and the related parts using the following table.
  - Replace any SRS components and the related parts showing visible signs of damage (dents, cracks, deformation).
3. Conduct self-diagnosis using CONSULT-II and "AIR BAG" warning lamp. Refer to [SRS-18, "SRS Operation Check"](#) for details. Ensure entire SRS operates properly.

### WHEN SRS IS NOT ACTIVATED IN THE SIDE OR ROLLOVER COLLISION

1. Check the SRS components and the related parts using the following table.
  - If the front seat back assembly is damaged, the front seat back assembly must be replaced.
2. Conduct self-diagnosis using CONSULT-II and "AIR BAG" warning lamp. Refer to [SRS-18, "SRS Operation Check"](#) for details. Ensure entire SRS operates properly.



# COLLISION DIAGNOSIS

## SRS INSPECTION (FOR SIDE AND ROLLOVER COLLISION)

Part	SRS is activated	SRS is NOT activated	A
LH side curtain air bag module	If the LH side curtain air bag has deployed: REPLACE the LH side curtain air bag module. (Repair the center pillar inner, etc. before installing new one if damaged.)	If the LH side curtain air bag has NOT deployed: 1. Check for visible signs of damage (dents, tears, deformation) of the center pillar on the collision side. 2. If damaged—Remove the LH side curtain air bag module. 3. Check for visible signs of damaged (tears etc.) of the LH side curtain air bag module. 4. Check harness and connectors for damage, and terminals for deformities. 5. If no damage is found, reinstall the LH side curtain air bag module with new fasteners. 6. If damaged—REPLACE the LH side curtain air bag module with new fasteners.	B C D
RH side curtain air bag module	If the RH side curtain air bag has deployed: REPLACE the RH side curtain air bag module. (Repair the center pillar inner, etc. before installing new one if damaged.)	If the RH side curtain air bag has NOT deployed: 1. Check for visible signs of damage (dents, tears, deformation) of the center pillar on the collision side. 2. If damaged—Remove the RH side curtain air bag module. 3. Check for visible signs of damaged (tears etc.) of the RH side curtain air bag module. 4. Check harness and connectors for damage, and terminals for deformities. 5. If no damage is found, reinstall the RH side curtain air bag module with new fasteners. 6. If damaged—REPLACE the RH side curtain air bag module with new fasteners.	E F G
Front LH side air bag module	If the front LH side air bag has deployed: REPLACE front LH seatback assembly.	If the front LH side air bag has NOT deployed: 1. Check for visible signs of damage (dents, tears, deformation) of the seat back on the collision side. 2. Check harness and connectors for damage, and terminals for deformities. 3. If damaged—REPLACE the front LH seatback assembly.	SRS I
Front RH side air bag module	If the front RH side air bag has deployed: REPLACE front RH seatback assembly.	If the front RH side air bag has NOT deployed: 1. Check for visible signs of damage (dents, tears, deformation) of the seat back on the collision side. 2. Check harness and connectors for damage, and terminals for deformities. 3. If damaged—REPLACE the front RH seatback assembly.	J K
(LH or RH) side air bag (satellite) sensor	If any of the SRS components have deployed: REPLACE the side air bag (satellite) sensor on the collision side with new fasteners. (Repair the center pillar inner, etc. before installing new one if damaged.)	If none of the SRS components have been activated: 1. Remove the side air bag (satellite) sensor on the collision side. Check harness connectors for damage, terminals for deformities, and harness for binding. 2. Check for visible signs of damage (dents, cracks, deformation) of the side air bag (satellite) sensor. 3. Install the side air bag (satellite) sensor to check fit. 4. If no damage is found, reinstall the side air bag (satellite) sensor with new fasteners. 5. If damaged—REPLACE the side air bag (satellite) sensor with new fasteners.	L M
Diagnosis sensor unit	If any of the SRS components have deployed: REPLACE the diagnosis sensor unit with new fasteners.	If none of the SRS components have been activated: 1. Check case and bracket for dents, cracks or deformities. 2. Check connectors for damage, and terminals for deformities. 3. If no damage is found, reinstall the diagnosis sensor unit with new fasteners. 4. If damaged—REPLACE the diagnosis sensor unit with new fasteners.	

## COLLISION DIAGNOSIS

Part	SRS is activated	SRS is NOT activated
Seat belt pre-tensioner assemblies (All applicable locations: buckle, reel, lap outer)	If either the driver or passenger seat belt pre-tensioner* has been activated: <b>REPLACE</b> all seat belt pre-tensioner assemblies with new fasteners.  *: Confirm seat belt pre-tensioner activation using CONSULT-II only.	If the pre-tensioners have NOT been activated: 1. Remove seat belt pre-tensioners. Check harness cover and connectors for damage, terminals for deformities, and harness for binding. 2. Check belts for damage and anchors for loose mounting. 3. Check retractor for smooth operation. 4. Check seat belt adjuster for damage. 5. Check for deformities of the center pillar inner. 6. If the center pillar inner has no damage, <b>REPLACE</b> the seat belt pre-tensioner assembly. 7. If no damage is found, reinstall seat belt pre-tensioner assembly. 8. If damaged— <b>REPLACE</b> . Install the seat belt pre-tensioners with new fasteners.
Seat (with front side air bag)	If either the front LH or front RH side air bag modules has been deployed: <b>REPLACE</b> front seat-back assembly on the deployed side.	If the front LH or front RH side air bag modules have NOT deployed: 1. Visually check the seat on the collision side. 2. Remove the seat on the collision side and check the following for damage and deformities. – Harness, connectors and terminals – Frame and recliner (for front and rear seat), and also adjuster and slides (for front seat) 3. If no damage is found, reinstall the seat. 4. If damaged— <b>REPLACE</b> the damaged seat parts using new fasteners. If the front seat back is damaged, the front seat back assembly must be replaced.
Center inner pillar	1. Check the center inner pillar on the collision side for damage (dents, cracks, deformation). 2. If damaged— <b>REPAIR</b> the center inner pillar.	
Trim/headlining	1. Check for visible signs of damage (dents, cracks, deformation) of the interior trim on the collision side. 2. If damaged— <b>REPLACE</b> the damaged trim parts.	