

SECTION **RF**
ROOF

A
B
C
D
E
F
G
H
RF
J
K
L
M

CONTENTS

PRECAUTIONS	2	SUNROOF/HEADLINING	7
Precautions for Supplemental Restraint System (SRS) "AIR BAG" and "SEAT BELT PRE-TENSIONER"	2	OVERHEAD CONSOLE (FRONT AND REAR).....	7
PREPARATION	3	SEATS	7
Special service tool	3	UNDERHOOD	7
Commercial Service Tool	3	Diagnostic Worksheet	8
SQUEAK AND RATTLE TROUBLE DIAGNOSES	4	SUNROOF	10
Work Flow	4	System Description	10
CUSTOMER INTERVIEW	4	POWER	10
DUPLICATE THE NOISE AND TEST DRIVE	5	TILT AND SLIDE OPERATION	10
CHECK RELATED SERVICE BULLETINS	5	Wiring Diagram — SROOF —	11
LOCATE THE NOISE AND IDENTIFY THE ROOT CAUSE	5	Memory Reset Adjustment	12
REPAIR THE CAUSE	5	Removal	13
CONFIRM THE REPAIR	6	SUNROOF LID ASSEMBLY	14
Generic Squeak and Rattle Troubleshooting	6	SHADE ASSEMBLY	14
INSTRUMENT PANEL	6	SUNROOF ASSEMBLY	14
CENTER CONSOLE	6	Trouble Diagnoses	15
DOORS	6	DIAGNOSTIC TABLE	15
TRUNK	7	ADJUSTMENT	15
		DRAIN HOSES	16
		WEATHERSTRIP	16
		LINK AND WIRE ASSEMBLY	16

PRECAUTIONS

PRECAUTIONS

PFP:00001

Precautions for Supplemental Restraint System (SRS) “AIR BAG” and “SEAT BELT PRE-TENSIONER”

EIS0016F

The Supplemental Restraint System such as “AIR BAG” and “SEAT BELT PRE-TENSIONER”, used along with a front seat belt, helps to reduce the risk or severity of injury to the driver and front passenger for certain types of collision. Information necessary to service the system safely is included in the SRS and SB section of this Service Manual.

WARNING:

- To avoid rendering the SRS inoperative, which could increase the risk of personal injury or death in the event of a collision which would result in air bag inflation, all maintenance must be performed by an authorized NISSAN/INFINITI dealer.
- Improper maintenance, including incorrect removal and installation of the SRS, can lead to personal injury caused by unintentional activation of the system. For removal of Spiral Cable and Air Bag Module, see the SRS section.
- Do not use electrical test equipment on any circuit related to the SRS unless instructed to in this Service Manual. SRS wiring harnesses can be identified by yellow and/or orange harness connectors.

PREPARATION

PREPARATION

PF0:00002

Special service tool

EIS0016G

The actual shapes of Kent-Moore tools may differ from those of special service tools illustrated here.

Tool number (Kent-Moore No.) Tool name	Description
— (J-39570) Chassis ear	Locating noise
— (J-43980) NISSAN Squeak and Rattle Kit	Repairing the cause of noise

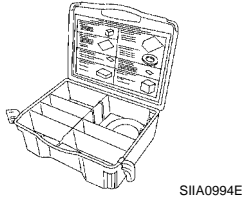
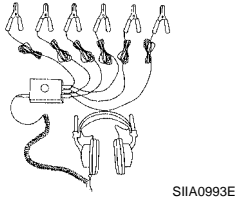

Commercial Service Tool

EIS0016H

Tool name (Kent-Moore No.)	Description
Engine ear (J-39565)	Locating noise

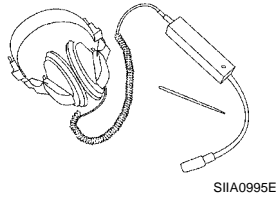

SQUEAK AND RATTLE TROUBLE DIAGNOSES

SQUEAK AND RATTLE TROUBLE DIAGNOSES

PF0:0000

Work Flow

EIS0047U

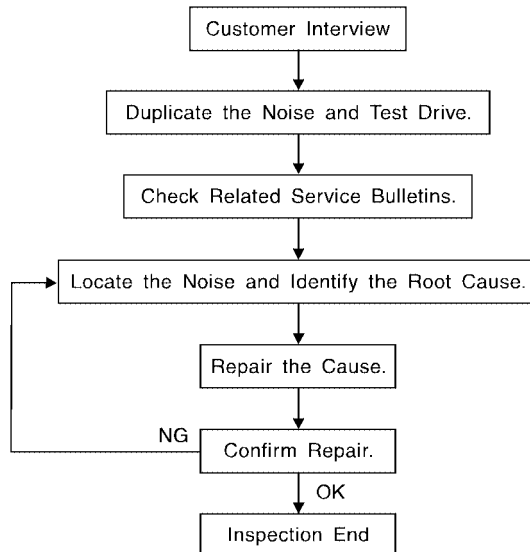

SBT842

CUSTOMER INTERVIEW

Interview the customer if possible, to determine the conditions that exist when the noise occurs. Use the Diagnostic Worksheet during the interview to document the facts and conditions when the noise occurs and any customer's comments; refer to [RF-8, "Diagnostic Worksheet"](#). This information is necessary to duplicate the conditions that exist when the noise occurs.

- The customer may not be able to provide a detailed description or the location of the noise. Attempt to obtain all the facts and conditions that exist when the noise occurs (or does not occur).
- If there is more than one noise in the vehicle, be sure to diagnose and repair the noise that the customer is concerned about. This can be accomplished by test driving the vehicle with the customer.
- After identifying the type of noise, isolate the noise in terms of its characteristics. The noise characteristics are provided so the customer, service adviser and technician are all speaking the same language when defining the noise.
- Squeak —(Like tennis shoes on a clean floor)
Squeak characteristics include the light contact/fast movement/brought on by road conditions/hard surfaces = higher pitch noise/softer surfaces = lower pitch noises/edge to surface = chirping.
- Creak—(Like walking on an old wooden floor)
Creak characteristics include firm contact/slow movement/twisting with a rotational movement/pitch dependent on materials/often brought on by activity.
- Rattle—(Like shaking a baby rattle)
Rattle characteristics include the fast repeated contact/vibration or similar movement/loose parts/missing clip or fastener/incorrect clearance.
- Knock —(Like a knock on a door)
Knock characteristics include hollow sounding/sometimes repeating/often brought on by driver action.
- Tick—(Like a clock second hand)
Tick characteristics include gentle contacting of light materials/loose components/can be caused by driver action or road conditions.
- Thump—(Heavy, muffled knock noise)
Thump characteristics include softer knock/dead sound often brought on by activity.
- Buzz—(Like a bumble bee)
Buzz characteristics include high frequency rattle/firm contact.
- Often the degree of acceptable noise level will vary depending upon the person. A noise that you may judge as acceptable may be very irritating to the customer.
- Weather conditions, especially humidity and temperature, may have a great effect on noise level.

SQUEAK AND RATTLE TROUBLE DIAGNOSES

DUPLICATE THE NOISE AND TEST DRIVE

If possible, drive the vehicle with the customer until the noise is duplicated. Note any additional information on the Diagnostic Worksheet regarding the conditions or location of the noise. This information can be used to duplicate the same conditions when you confirm the repair.

If the noise can be duplicated easily during the test drive, to help identify the source of the noise, try to duplicate the noise with the vehicle stopped by doing one or all of the following:

- 1) Close a door.
 - 2) Tap or push/pull around the area where the noise appears to be coming from.
 - 3) Rev the engine.
 - 4) Use a floor jack to recreate vehicle "twist".
 - 5) At idle, apply engine load (electrical load, half-clutch on M/T model, drive position on A/T model).
 - 6) Raise the vehicle on a hoist and hit a tire with a rubber hammer.
- Drive the vehicle and attempt to duplicate the conditions the customer states exist when the noise occurs.
 - If it is difficult to duplicate the noise, drive the vehicle slowly on an undulating or rough road to stress the vehicle body.

CHECK RELATED SERVICE BULLETINS

After verifying the customer concern or symptom, check ASIST for Technical Service Bulletins (TSBs) related to that concern or symptom.

If a TSB relates to the symptom, follow the procedure to repair the noise.

LOCATE THE NOISE AND IDENTIFY THE ROOT CAUSE

1. Narrow down the noise to a general area. To help pinpoint the source of the noise, use a listening tool (Chassis Ear: J-39570, Engine Ear: J-39565 and mechanic's stethoscope).
2. Narrow down the noise to a more specific area and identify the cause of the noise by:
 - removing the components in the area that you suspect the noise is coming from. Do not use too much force when removing clips and fasteners, otherwise clips and fasteners can be broken or lost during the repair, resulting in the creation of new noise.
 - tapping or pushing/pulling the component that you suspect is causing the noise. Do not tap or push/pull the component with excessive force, otherwise the noise will be eliminated only temporarily.
 - feeling for a vibration with your hand by touching the component(s) that you suspect is (are) causing the noise.
 - placing a piece of paper between components that you suspect are causing the noise.
 - looking for loose components and contact marks.
Refer to [RF-6, "Generic Squeak and Rattle Troubleshooting"](#).

REPAIR THE CAUSE

- If the cause is a loose component, tighten the component securely.
- If the cause is insufficient clearance between components:
 - separate components by repositioning or loosening and retightening the component, if possible.
 - insulate components with a suitable insulator such as urethane pads, foam blocks, felt cloth tape or urethane tape. A NISSAN Squeak and Rattle Kit (J-43980) is available through your authorized NISSAN Parts Department.

CAUTION:

Do not use excessive force as many components are constructed of plastic and may be damaged.

Always check with the Parts Department for the latest parts information.

The following materials are contained in the NISSAN Squeak and Rattle Kit (J-43980). Each item can be ordered separately as needed.

URETHANE PADS [1.5 mm (0.059 in) thick]

Insulates connectors, harness, etc.

76268-9E005: 100×135 mm (3.94×5.31 in)/76884-71L01: 60×85 mm (2.36×3.35 in)/76884-71L02: 15×25 mm (0.59×0.98 in)

INSULATOR (Foam blocks)

Insulates components from contact. Can be used to fill space behind a panel.

73982-9E000: 45 mm (1.77 in) thick, 50×50 mm (1.97×1.97 in)/73982-50Y00: 10 mm (0.39 in) thick, 50×50 mm (1.97×1.97 in)

INSULATOR (Light foam block)

SQUEAK AND RATTLE TROUBLE DIAGNOSES

80845-71L00: 30 mm (1.18 in) thick, 30×50 mm (1.18×1.97 in)

FELT CLOTH TAPE

Used to insulate where movement does not occur. Ideal for instrument panel applications.

68370-4B000: 15×25 mm (0.59×0.98 in) pad/**68239-13E00:** 5 mm (0.20 in) wide tape roll. The following materials not found in the kit can also be used to repair squeaks and rattles.

UHMW (TEFLON) TAPE

Insulates where slight movement is present. Ideal for instrument panel applications.

SILICONE GREASE

Used instead of UHMW tape that will be visible or not fit.

Note: Will only last a few months.

SILICONE SPRAY

Use when grease cannot be applied.

DUCT TAPE

Use to eliminate movement.

CONFIRM THE REPAIR

Confirm that the cause of a noise is repaired by test driving the vehicle. Operate the vehicle under the same conditions as when the noise originally occurred. Refer to the notes on the Diagnostic Worksheet.

Generic Squeak and Rattle Troubleshooting

EIS0047V

Refer to Table of Contents for specific component removal and installation information.

INSTRUMENT PANEL

Most incidents are caused by contact and movement between:

1. The cluster lid A and instrument panel
2. Acrylic lens and combination meter housing
3. Instrument panel to front pillar garnish
4. Instrument panel to windshield
5. Instrument panel mounting pins
6. Wiring harnesses behind the combination meter
7. A/C defroster duct and duct joint

These incidents can usually be located by tapping or moving the components to duplicate the noise or by pressing on the components while driving to stop the noise. Most of these incidents can be repaired by applying felt cloth tape or silicone spray (in hard to reach areas). Urethane pads can be used to insulate wiring harness.

CAUTION:

Do not use silicone spray to isolate a squeak or rattle. If you saturate the area with silicone, you will not be able to recheck the repair.

CENTER CONSOLE

Components to pay attention to include:

1. Shifter assembly cover to finisher
2. A/C control unit and cluster lid C
3. Wiring harnesses behind audio and A/C control unit

The instrument panel repair and isolation procedures also apply to the center console.

DOORS

Pay attention to the:

1. Finisher and inner panel making a slapping noise
2. Inside handle escutcheon to door finisher
3. Wiring harnesses tapping
4. Door striker out of alignment causing a popping noise on starts and stops

Tapping or moving the components or pressing on them while driving to duplicate the conditions can isolate many of these incidents. You can usually insulate the areas with felt cloth tape or insulator foam blocks from the NISSAN Squeak and Rattle Kit (J-43980) to repair the noise.

SQUEAK AND RATTLE TROUBLE DIAGNOSES

TRUNK

Trunk noises are often caused by a loose jack or loose items put into the trunk by the owner. In addition look for:

1. Trunk lid bumpers out of adjustment
2. Trunk lid striker out of adjustment
3. The trunk lid torsion bars knocking together
4. A loose license plate or bracket

Most of these incidents can be repaired by adjusting, securing or insulating the item(s) or component(s) causing the noise.

SUNROOF/HEADLINING

Noises in the sunroof/headlining area can often be traced to one of the following:

1. Sunroof lid, rail, linkage or seals making a rattle or light knocking noise
2. Sun visor shaft shaking in the holder
3. Front or rear windshield touching headliner and squeaking

Again, pressing on the components to stop the noise while duplicating the conditions can isolate most of these incidents. Repairs usually consist of insulating with felt cloth tape.

OVERHEAD CONSOLE (FRONT AND REAR)

Overhead console noises are often caused by the console panel clips not being engaged correctly. Most of these incidents are repaired by pushing up on the console at the clip locations until the clips engage.

In addition look for :

1. Loose harness or harness connectors.
2. Front console map/reading lamp lense loose.
3. Loose screws at console attachment points.

SEATS

When isolating seat noise it's important to note the position the seat is in and the load placed on the seat when the noise is present. These conditions should be duplicated when verifying and isolating the cause of the noise.

Cause of seat noise include:

1. Headrest rods and holder
2. A squeak between the seat pad cushion and frame
3. The rear seat back lock and bracket

These noises can be isolated by moving or pressing on the suspected components while duplicating the conditions under which the noise occurs. Most of these incidents can be repaired by repositioning the component or applying urethane tape to the contact area.

UNDERHOOD

Some interior noise may be caused by components under the hood or on the engine wall. The noise is then transmitted into the passenger compartment.

Causes of transmitted underhood noise include:

1. Any component mounted to the engine wall
2. Components that pass through the engine wall
3. Engine wall mounts and connectors
4. Loose radiator mounting pins
5. Hood bumpers out of adjustment
6. Hood striker out of adjustment

These noises can be difficult to isolate since they cannot be reached from the interior of the vehicle. The best method is to secure, move or insulate one component at a time and test drive the vehicle. Also, engine RPM or load can be changed to isolate the noise. Repairs can usually be made by moving, adjusting, securing, or insulating the component causing the noise.

A

B

C

D

E

F

G

H

RF

J

K

L

M

SQUEAK AND RATTLE TROUBLE DIAGNOSES

Diagnostic Worksheet

EIS0047W



SQUEAK & RATTLE DIAGNOSTIC WORKSHEET

Dear Nissan Customer:

We are concerned about your satisfaction with your Nissan vehicle. Repairing a squeak or rattle sometimes can be very difficult. To help us fix your Nissan right the first time, please take a moment to note the area of the vehicle where the squeak or rattle occurs and under what conditions. You may be asked to take a test drive with a service advisor or technician to ensure we confirm the noise you are hearing.

I. WHERE DOES THE NOISE COME FROM? (circle the area of the vehicle)

The illustrations are for reference only, and may not reflect the actual configuration of your vehicle.

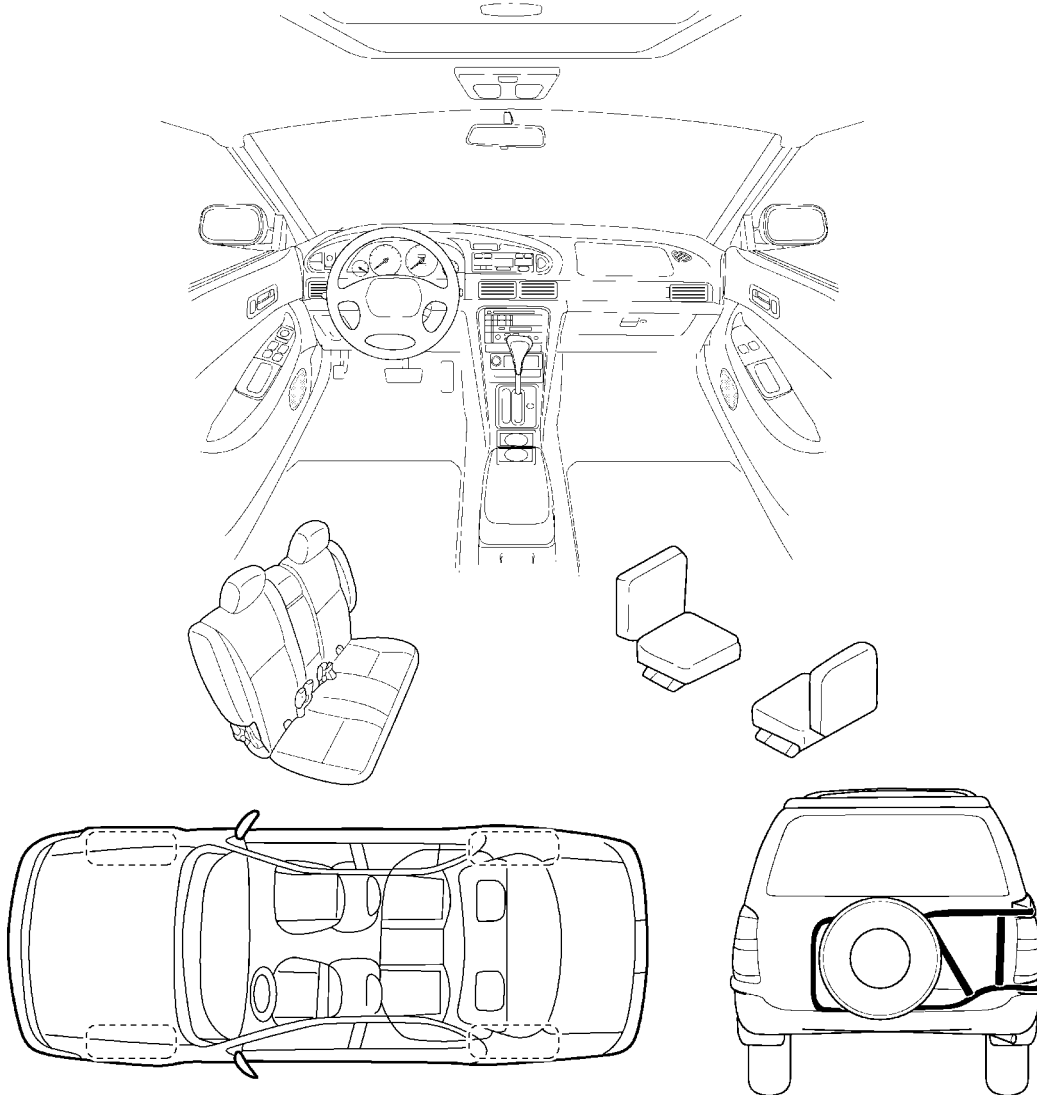

Continue to the back of the worksheet and briefly describe the location of the noise or rattle. In addition, please indicate the conditions which are present when the noise occurs.

LIWA0276E

SQUEAK AND RATTLE TROUBLE DIAGNOSES

SQUEAK & RATTLE DIAGNOSTIC WORKSHEET- page 2

Briefly describe the location where the noise occurs:

II. WHEN DOES IT OCCUR? (check the boxes that apply)

- | | |
|--|---|
| <input type="checkbox"/> anytime | <input type="checkbox"/> after sitting out in the sun |
| <input type="checkbox"/> 1 st time in the morning | <input type="checkbox"/> when it is raining or wet |
| <input type="checkbox"/> only when it is cold outside | <input type="checkbox"/> dry or dusty conditions |
| <input type="checkbox"/> only when it is hot outside | <input type="checkbox"/> other: _____ |

III. WHEN DRIVING:

- through driveways
- over rough roads
- over speed bumps
- only at about ____ mph
- on acceleration
- coming to a stop
- on turns : left, right or either (circle)
- with passengers or cargo
- other: _____
- after driving ____ miles or ____ minutes

IV. WHAT TYPE OF NOISE?

- squeak (like tennis shoes on a clean floor)
- creak (like walking on an old wooden floor)
- rattle (like shaking a baby rattle)
- knock (like a knock on a door)
- tick (like a clock second hand)
- thump (heavy, muffled knock noise)
- buzz (like a bumble bee)

TO BE COMPLETED BY DEALERSHIP PERSONNEL

Test Drive Notes:

	YES	NO	Initials of person performing
Vehicle test driven with customer	<input type="checkbox"/>	<input type="checkbox"/>	_____
- Noise verified on test drive	<input type="checkbox"/>	<input type="checkbox"/>	_____
- Noise source located and repaired	<input type="checkbox"/>	<input type="checkbox"/>	_____
- Follow up test drive performed to confirm repair	<input type="checkbox"/>	<input type="checkbox"/>	_____

VIN: _____ Customer Name: _____

W.O. #: _____ Date: _____

SBT844

This form must be attached to Work Order

SUNROOF

PFP:91210

System Description POWER

EIS0016L

Power is supplied at all times:

- through 30A fusible link (letter **d** , located in the fuse and fusible link box)
- to sunroof motor assembly terminal 5.

The power circuit is protected by the circuit breaker. The sunroof motor assembly is grounded through body ground R5.

NOTE:

When the battery or sunroof motor harness connector is disconnected during service, the sunroof will not operate properly.

Procedure for resetting motor memory:

From any sunroof position (full open, partially open, closed, partially vented, and vented), push and hold the button in the forward position until the sunroof vent is in the full up position. This resets the sunroof motor memory and the sunroof will operate correctly.

TILT AND SLIDE OPERATION

The sunroof is controlled by the sunroof switch. With the sunroof in the closed position, depressing the UP/CLOSE switch will tilt the rear of the sunroof up. The sunroof will stop when the switch is released, or when the sunroof reaches its maximum tilt position.

The sunroof will tilt down when in the tilt up position and the DOWN/OPEN switch is depressed. The sunroof will stop when the switch is released, or when the sunroof is fully closed.

With the sunroof in the closed position, pressing the DOWN/OPEN switch will cause the sunroof to slide open. The sunroof will slide open until the switch is released or until it is all the way open. The sunroof will close when in the open position, and the UP/CLOSE switch is depressed. The sunroof will slide until the switch is released, or when the sunroof is fully closed.

All automatic operations in sunroof are controlled by internal limit switches located in the sunroof motor assembly.

SUNROOF

Wiring Diagram — SROOF —

EIS0016M

RF-SROOF-01

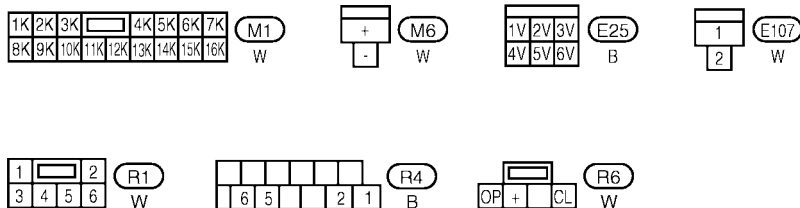
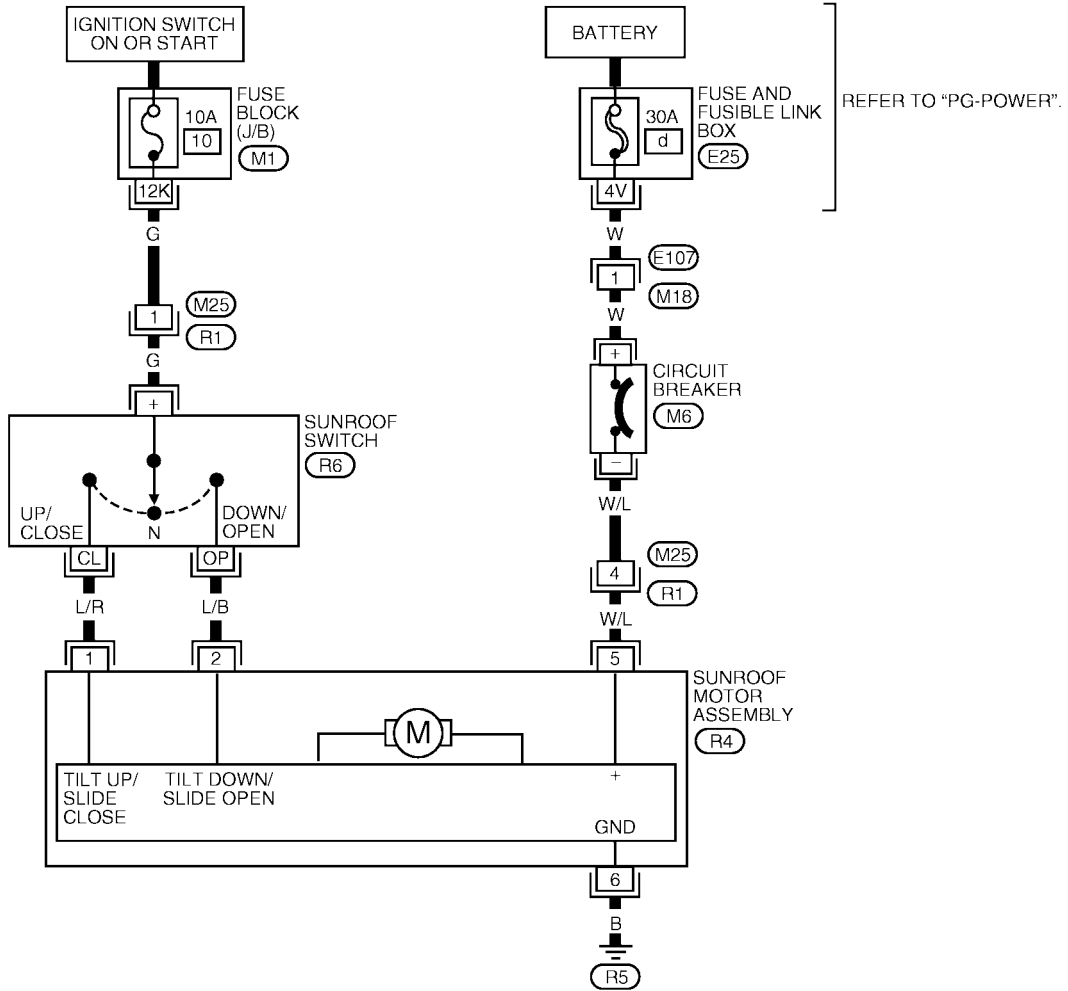

W1WA0001E

SUNROOF

EIS0016N

Memory Reset Adjustment

If the battery is disconnected or the sunroof motor harness connector is disconnected, the sunroof motor memory must be reset. To reset the sunroof motor memory from any sunroof position (full open, partially open, closed, partially vented, and vented), push and hold the sunroof button in the forward position until the sunroof vents in the full up position. This resets the sunroof motor memory and now the sunroof will operate correctly.

Install motor and limit SW assembly and sunroof rail assembly in the following sequence:

1. Arrange equal lengths of link and wire assemblies on both sides of the sunroof opening.
2. Connect the sunroof connector to the sunroof switch and positive (+) power supply.
3. Set the lid assembly to the fully closed position **A** by operating the sunroof switch.
4. Fit the outer side of the lid assembly to the surface of the roof outer body panel.
5. Remove the motor and keep the DOWN/OPEN switch depressed until the motor pinion gear reaches the end of its rotating range.
6. Install the motor.
7. Check that the motor drive gear fits properly in wires.
8. Press the UP/CLOSE switch to check the lid assembly for normal tilting.
9. Check the sunroof lid assembly for normal operations (tilt up, tilt down, open and close).

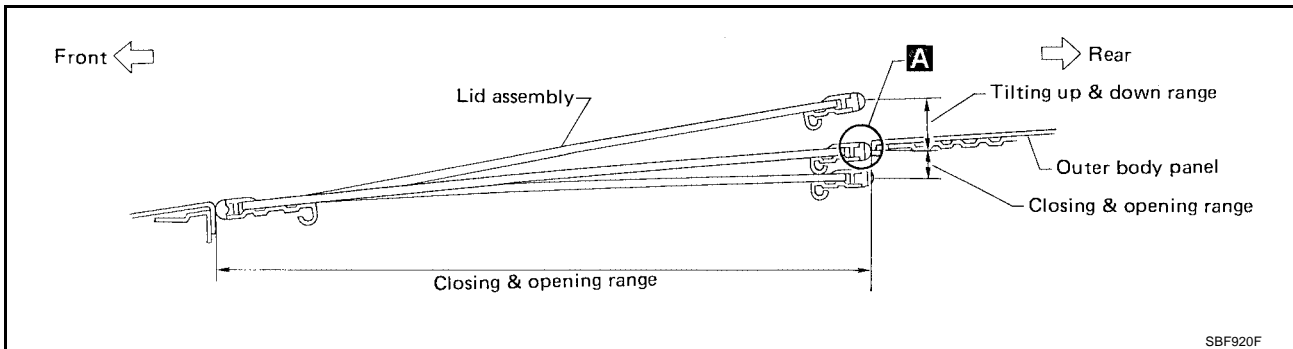

SUNROOF

EIS00160

Removal

SEC. 736

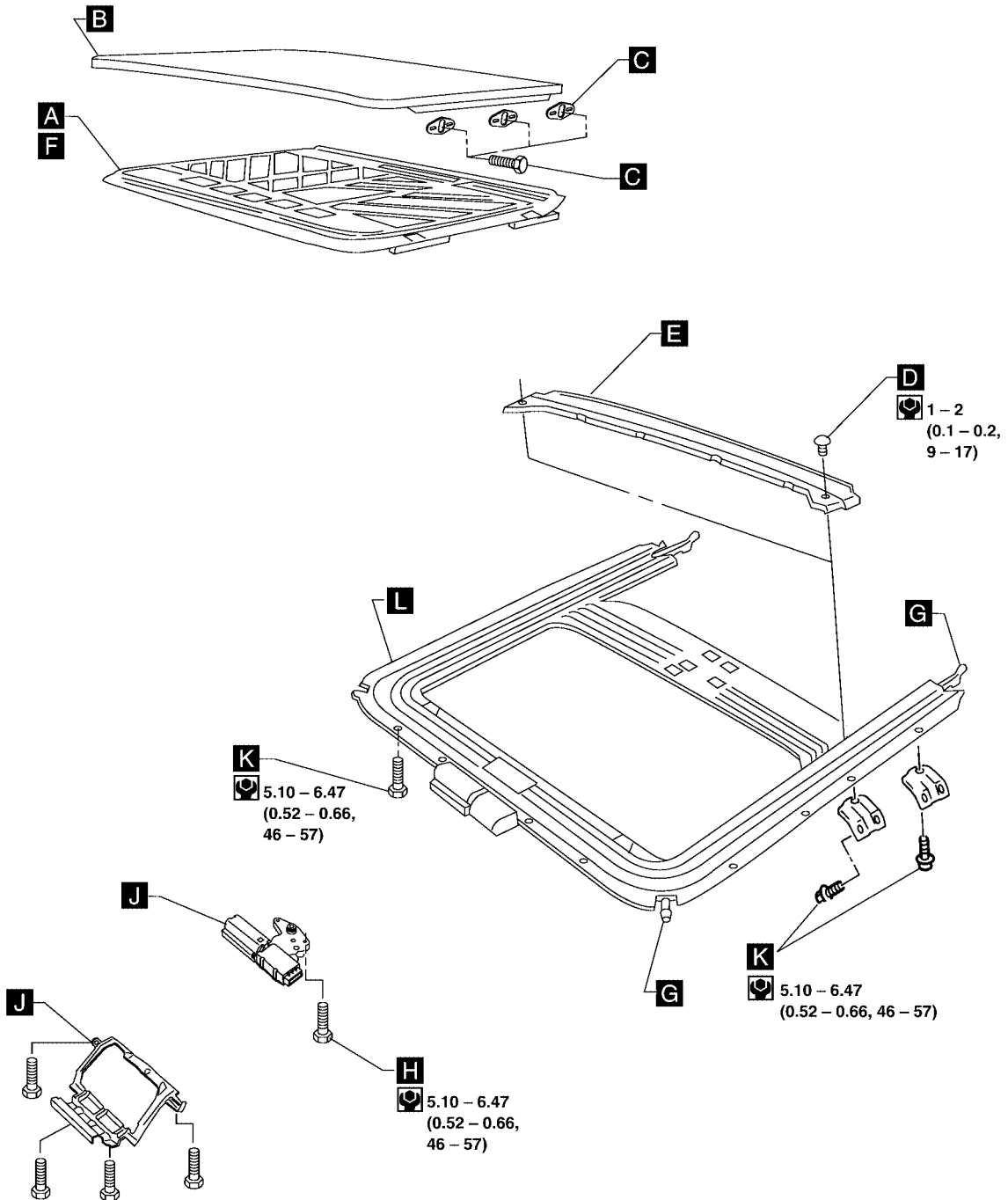

: N-m (kg-m, in-lb)

WIIA0001E

- After any repair, check sunroof operation and glass lid alignment.
- Handle the finisher plate and glass lid with care so as not to cause damage.
- To ease installation, mark each point before removal.

CAUTION:

- Always work with a helper.

SUNROOF

- Before removal, fully close the glass lid assembly, then after removal, do not move the motor assembly.

SUNROOF LID ASSEMBLY

1. Open the sunroof shade. **A**
2. Close the glass lid. **B**
3. Remove the six bolts securing the glass lid assembly to the sunroof assembly. **C**

SHADE ASSEMBLY

1. After removing the glass lid assembly, remove the two screws securing the drain channel. **D**
2. Remove the drain channel. **E**
3. Remove the shade assembly. **F**

SUNROOF ASSEMBLY

1. Remove the headlining. Refer to [EI-32, "Removal and Installation"](#) .
2. Disconnect the front and rear drain hoses. **G**
3. Remove the two screws securing the sunroof motor to the sunroof assembly. **H**
4. Remove the sunroof motor and bracket. **J**
5. Remove bolts securing the sunroof assembly to the roof. **K**
6. Remove the sunroof assembly. **L**

SUNROOF

Trouble Diagnoses DIAGNOSTIC TABLE

EIS0016P

		Check items (Components)			
		Adjustment	Drain hoses	Weatherstrip	Link and wire assembly
	Reference page	RF-15. "ADJUSTMENT"	RF-16. "DRAIN HOSES"	RF-16. "WEATHER- STRIP"	RF-16. "LINK AND WIRE ASSEMBLY"
Symptom	Excessive wind noise	1		2	
	Water leaks	1	2	3	
	Sunroof rattles	1	4	2	3
	Excessive operation noise	1		2	3

The numbers in this table mean checking order.

ADJUSTMENT

SEC. 736

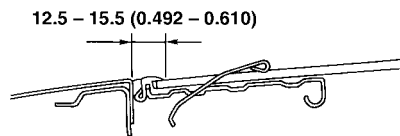
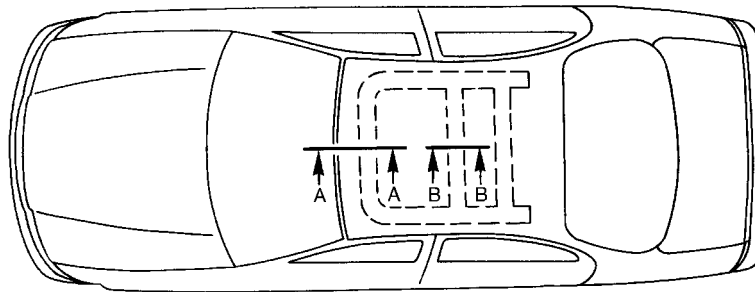

A - A

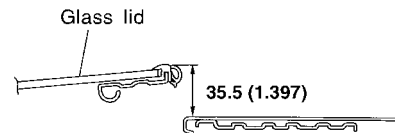

B - B (When sunroof is tilted up)

Unit: mm (in)

WBT061

If any gap or height difference between glass lid and roof is found, check glass lid fit and adjust as follows:

Gap Adjustment

1. Open the shade assembly.
2. Tilt the glass lid up then remove the side trim.
3. Loosen the glass lid securing bolts (3 each on left and right sides), then tilt the glass lid down.
4. Adjust the glass lid from outside of vehicle so it resembles "A-A" as shown in the figure above.
5. Tilt the glass lid up and down until it is adjusted to "B-B" as shown in the figure above.
6. After adjusting the glass lid, tilt the glass lid up and tighten the bolts.
7. Tilt the glass lid up and down several times to check that it moves smoothly.

SUNROOF

Height Difference Adjustment

1. Tilt the glass lid up and down.
2. Check the height difference between the roof panel and the glass lid to see if it is as "A-A" as shown in the figure above.
3. If necessary, adjust it by using one of following procedures.
 - Adjust by adding or removing adjustment shim(s) between the glass lid and link assembly.
 - If the glass lid protrudes above the roof panel, add shim(s) or plain washer(s) at the sunroof mounting bracket or stud bolt locations to adjust sunroof installation as required.

DRAIN HOSES

1. Remove the headlining to access the drain hose connections. (Refer to [EI-32, "Removal and Installation"](#) .)

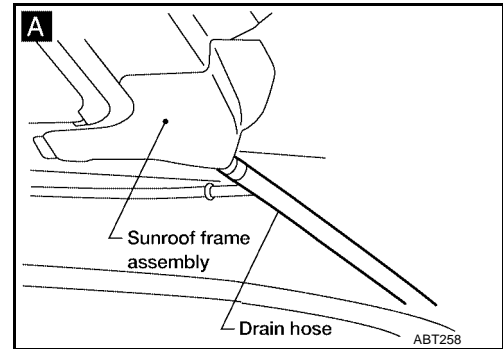

2. Check visually for proper connections, damage or deterioration. **A** (The figure shows only the front side.)
3. If leakage occurs around the trunk room side trim and check connecting area. Check for proper connection or damage.
4. Remove the drain hoses and check visually for any damage, cracks or deterioration.
5. Pour water into the drain hoses to find the damaged portion.
 - If any damaged portion is found at each step, replace the damaged hose.

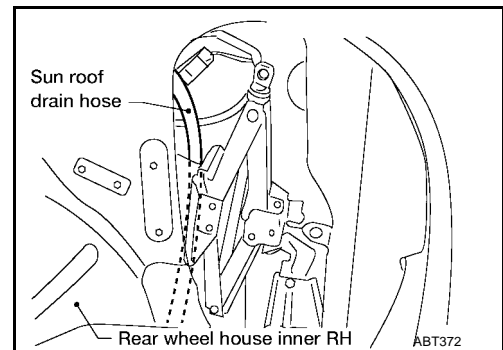

WEATHERSTRIP

- In case of leakage around the roof lid, close it and pour water over the roof lid to find the damaged or gap portion.
- If gap is between the weatherstrip and the roof panel, perform gap adjustment. Refer to [RF-15, "Gap Adjustment"](#) .
- If gap is between the weatherstrip and the roof lid, or if weatherstrip is flattened, damaged or deteriorated, replace the roof lid assembly. (Weatherstrip is not serviceable.)

LINK AND WIRE ASSEMBLY

NOTE:

Before replacing a suspect part, carefully ensure it is the source of noise being experienced.

1. Check link to determine if coating film has peeled off to such an extent that substrate is visible. Check also to determine if link is the source of noise. If it is, replace it.
2. Visually check to determine if a sufficient amount of petroleum jelly has been applied to wire or rail groove. If not, add petroleum jelly as required.
3. Check wire for any damage or deterioration. If damaged, replace wire.