

A
LU

SECTION LU

ENGINE LUBRICATION SYSTEM

C

CONTENTS

QG18DE	QR25DE
PRECAUTIONS 2	PRECAUTIONS 12
Precautions for Liquid Gasket 2	Precautions for Liquid Gasket 12
REMOVAL OF LIQUID GASKET SEALING 2	REMOVAL OF LIQUID GASKET SEALING 12
LIQUID GASKET APPLICATION PROCEDURE 2	LIQUID GASKET APPLICATION PROCEDURE .. 12
PREPARATION 3	PREPARATION 13
Special Service Tools 3	Special Service Tools 13
LUBRICATION SYSTEM 4	LUBRICATION SYSTEM 14
Lubrication Circuit 4	Lubrication Circuit 14
ENGINE OIL 5	ENGINE OIL 16
Inspection 5	Inspection 16
OIL LEVEL AND MUDDINESS 5	OIL LEVEL AND MUDINESS 16
OIL LEAKAGE 5	OIL LEAKAGE 16
OIL PRESSURE CHECK 5	OIL PRESSURE CHECK 16
Changing Engine Oil 6	Changing Engine Oil 17
OIL FILTER 7	OIL FILTER 18
Removal and Installation 7	Removal and Installation 18
REMOVAL 7	REMOVAL 18
INSTALLATION 7	INSTALLATION 18
OIL PUMP 8	OIL PUMP 19
Removal and Installation 8	Removal and Installation 19
Disassembly and Assembly 8	Disassembly and Assembly 19
Inspection 8	DISASSEMBLY 19
Regulator Valve Inspection 10	INSPECTION AFTER DISASSEMBLY 19
SERVICE DATA AND SPECIFICATIONS (SDS) 11	ASSEMBLY 21
Oil Pressure 11	SERVICE DATA AND SPECIFICATIONS (SDS) 22
Oil Pump 11	Oil Pressure 22
Regulator Valve 11	Oil Pump 22
Oil Capacity 11	Regulator Valve 22
	Oil Capacity 22

PRECAUTIONS

Precautions for Liquid Gasket

REMOVAL OF LIQUID GASKET SEALING

- After removing the mounting bolts and nuts, disconnect and remove the sealant using a seal cutter.

CAUTION:

Be careful not to damage the mating surfaces.

- In areas where the cutter is difficult to use, use a plastic hammer to lightly tap the areas where the sealant is applied.

CAUTION:

If for some unavoidable reason a tool such as a flat-bladed screwdriver is used, be careful not to damage the mating surfaces.

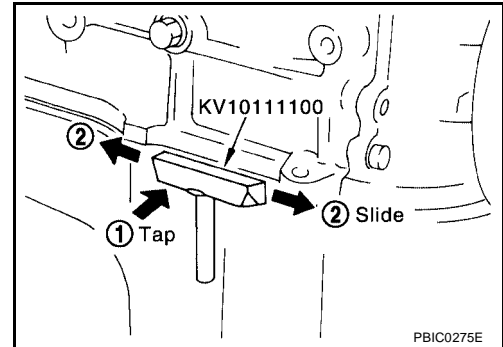

LIQUID GASKET APPLICATION PROCEDURE

- Using a scraper, remove the old sealant adhering to the gasket application surface and the mating surface.
 - Remove the old sealant completely from the groove of the gasket application surface, mounting bolts, and bolt holes.
- Clean the mating surface to remove dirt, moisture, grease, and foreign material.
- Attach the sealant tube to the tube presser.

Use Genuine RTV Silicone Sealant or equivalent. Refer to [GI-46. "RECOMMENDED CHEMICAL PRODUCTS AND SEALANTS"](#).

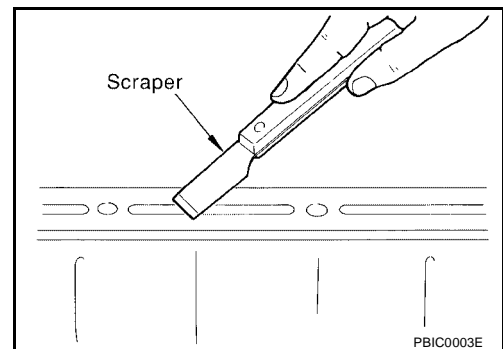

- Apply the sealant without breaks to the specified location with the specified dimensions.
 - If there is a groove for the sealant application, apply the Sealant to the groove.
 - As for the bolt holes, normally apply the sealant inside the holes. Occasionally, it should be applied outside the holes.

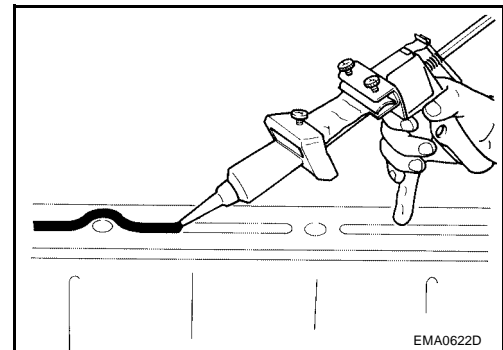

- Within five minutes of sealant application, install the mating component.
- If the sealant protrudes, wipe it off immediately.
- Do not retighten after the installation.
- After 30 minutes or more have passed after installation, fill the engine with oil and coolant.

CAUTION:

If there are specific instructions in the service manual, observe them.

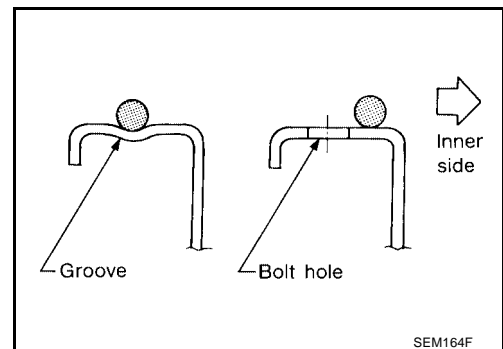

PREPARATION

[QG18DE]

PFP:00002

EBS00CGC

PREPARATION

Special Service Tools

The actual shapes of Kent-Moore tools may differ from those of special service tools illustrated here.

Tool number (Kent-Moore No.) Tool name	Description
(J34301-C) Oil pressure gauge set 1. (J34301-1) Oil pressure gauge 2. (J34301-2) Hoses 3. (J34298) Adapter 4. (J34282-1) Adapter 5. (790-301-1230-A) 60° adapter 6. (J34301-15) Square socket	Measuring oil pressure Maximum measuring range: 1,373 kPa (14 kg/cm² , 199 psi)
KV10115800 (J-37140-A) Oil filter wrench	Removing and installing oil filter
WS39930000 (—) Tube presser	Pressing the tube of liquid gasket

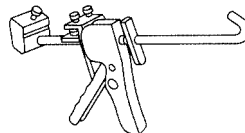
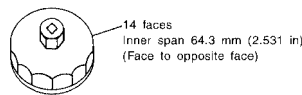
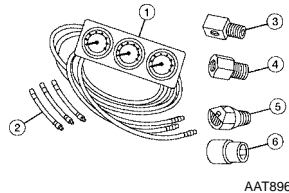

A

LU

C

D

E

F

G

H

I

J

K

L

M

LUBRICATION SYSTEM

[QG18DE]

PF1:15010

EBS00CGD

LUBRICATION SYSTEM

Lubrication Circuit

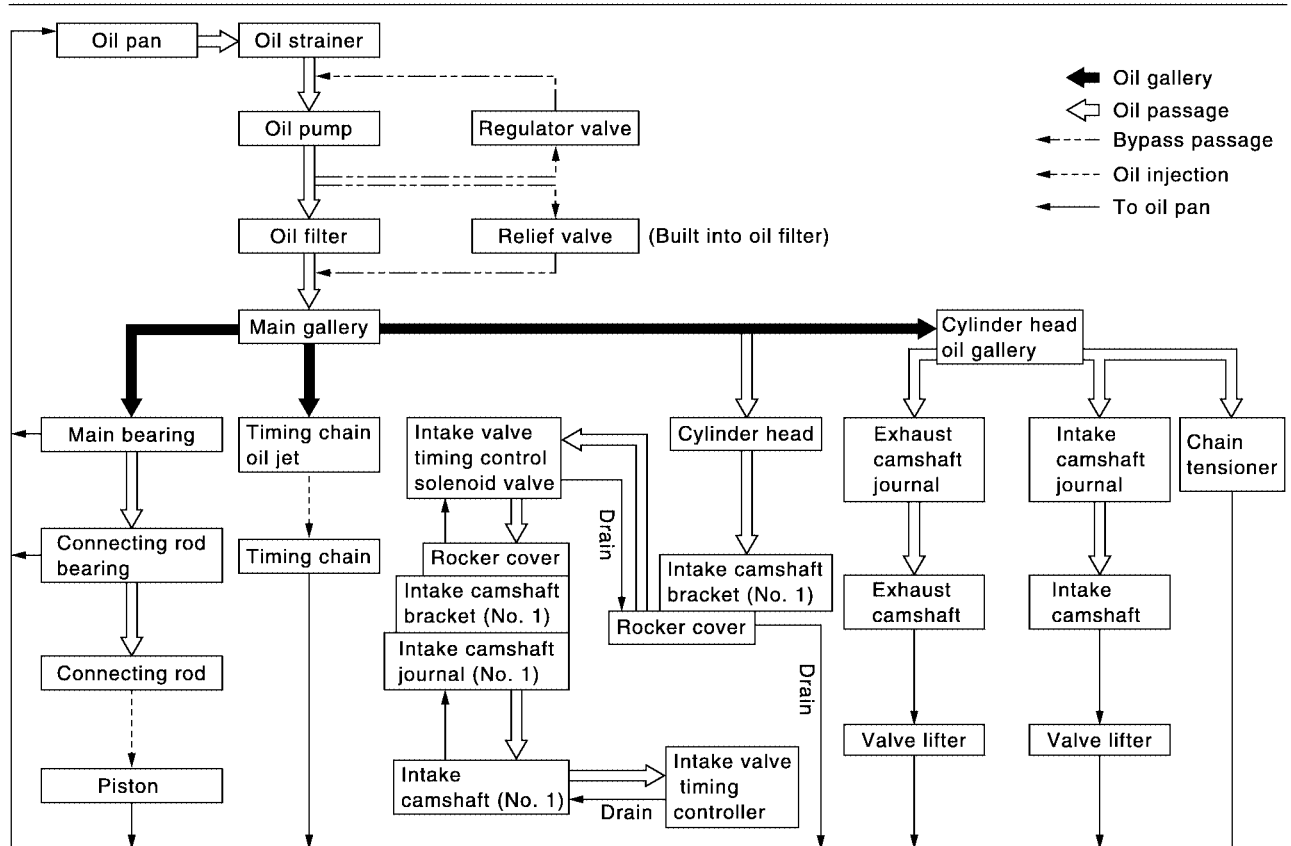
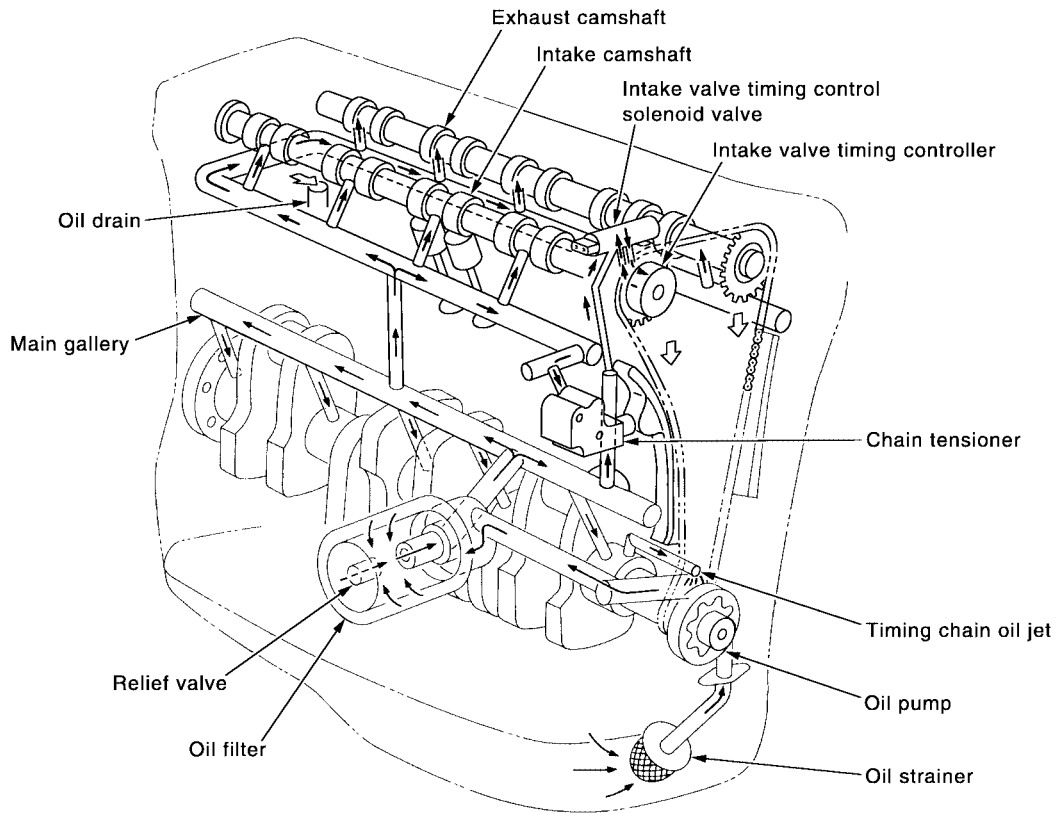

PBIC1071E

ENGINE OIL

Inspection

OIL LEVEL AND MUDDINESS

- Ensure the vehicle is on a level surface with engine off, then check the oil level. If the engine is already started, stop it and allow 10 minutes before checking.
- Check that the oil level is within the range shown in the figure.
- If it is out of range, add oil as necessary. Refer to [MA-13, "RECOMMENDED FLUIDS AND LUBRICANTS"](#) .
- Check the oil for white turbidity or remarkable contamination.
- If the oil becomes turbid and white, it is highly probable that it is contaminated with coolant. Diagnose the problem and correct as necessary.

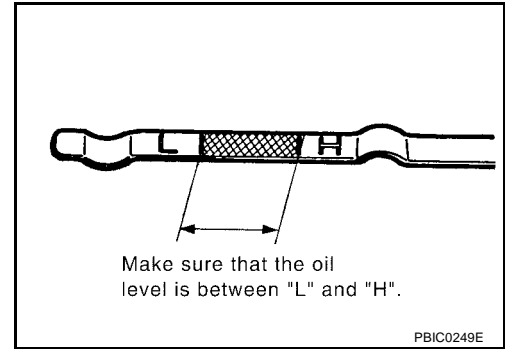

OIL LEAKAGE

Check for oil leakage around the following areas.

- Oil pan
- Oil pan drain plug
- Oil pressure switch
- Oil filter
- Front cover
- Mating surface between cylinder block and cylinder head
- Mating surface between cylinder head and rocker cover
- Crankshaft oil seal.

OIL PRESSURE CHECK

WARNING:

- **Be careful not to burn yourself, as the engine oil may be hot.**
 - **For M/T models, put gearshift lever in Neutral. For A/T models, put the selector lever in Park "P" position.**
1. Check the oil level.
 2. Remove the oil pressure switch.
 3. Connect the oil pressure gauge using the Tool.
 4. After warming up the engine to the normal operating temperature, check that oil pressure corresponding to the engine speed is produced.

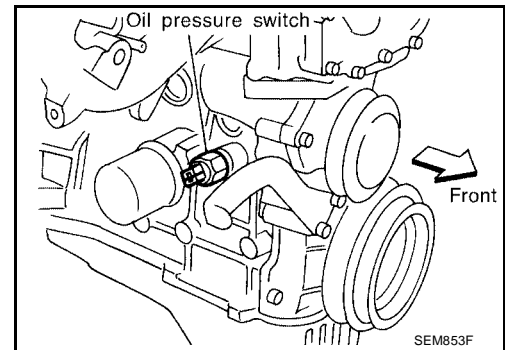

Engine oil pressure [Oil temperature is 80°C (176°F)]

Engine speed (rpm)	Idle speed	2,000	6,000
Engine pressure kPa (kg/cm ² , psi)	Approx. 98 (1.0, 14) or more	Approx. 294 (3.0, 43) or more	Approx. 392 (4.0, 57) or more

5. After checking, install the oil pressure switch as follows.
 - a. Remove old sealant adhering to the switch and engine.
 - b. Apply thread sealant. Tighten switch to specification.
Use Genuine High Performance Thread Sealant or equivalent. Refer to [GI-46, "RECOMMENDED CHEMICAL PRODUCTS AND SEALANTS"](#) .

Oil pressure switch : 12 - 17 N-m (1.22 - 1.73 kg-m, 8.8 - 12.5 ft-lb)

Changing Engine Oil

WARNING:

- Be careful not to burn yourself, as the engine oil may be hot.
 - Prolonged and repeated contact with used engine oil may cause skin cancer: try to avoid direct skin contact with used oil. If skin contact is made, wash thoroughly with soap or hand cleaner as soon as possible.
1. Warm up engine, and check for oil leakage from engine components.
 2. Stop engine and wait for 10 minutes.
 3. Remove drain plug and oil filler cap to drain the oil.
 4. Remove the oil filter and install a new filter.
 5. Install the oil pan drain plug with a new washer.

CAUTION:

- Be sure to clean the drain plug and install with new washer.
 Oil pan drain plug : 29 - 39 N-m (3.0 - 4.0 kg-m, 22 - 29 ft-lb)
 - The refill capacity depends on the oil temperature and drain time. Use these specifications for reference only.
 Always use the dipstick to determine that the proper amount of oil is in the engine.
6. Fill the engine with oil.

Oil specification and viscosity

- Refer to [MA-13, "Fluids and Lubricants"](#) .

Oil capacity (Approximate):

Drain and refill	With oil filter change	2.7 ℓ (2-7/8 US qt, 2-3/8 Imp qt)
	Without oil filter change	2.5 ℓ (2-5/8 US qt, 2-1/4 Imp qt)
Dry engine (engine overhaul)		3.1 ℓ (3-1/4 US qt, 2-3/4 Imp qt)

7. Warm up the engine and check the area around the drain plug and oil filter for oil leakage.
8. Stop the engine and wait for 10 minutes.
9. Check the oil level. Refer to [LU-5, "ENGINE OIL"](#) .

OIL FILTER

Removal and Installation

REMOVAL

1. Remove the RH engine under cover.
2. Using an oil filter wrench, remove the oil filter.

CAUTION:

- Be careful not to get burned when the engine and engine oil are hot.
- When removing, prepare a shop cloth to absorb any oil leakage or spillage.
- Do not allow engine oil to adhere to the drive belts.
- Completely wipe off any oil that adheres to the engine and the vehicle.

INSTALLATION

1. Remove foreign materials adhering to the oil filter installation surface.
2. Apply engine oil to the oil seal circumference of the new oil filter.

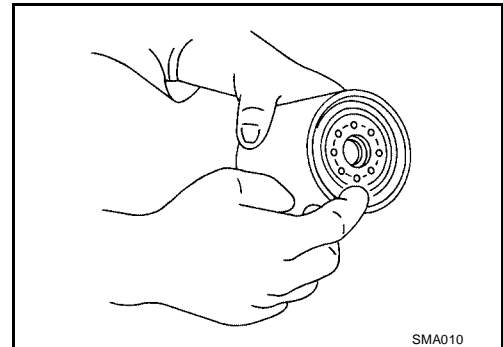

3. Screw the oil filter manually until it touches the installation surface, then tighten it by 2/3 turn.

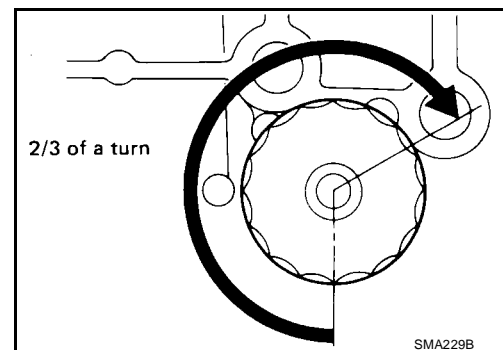

4. After warming up the engine, check for engine oil leakage.
5. Check oil level with the dipstick and add engine oil as necessary. Refer to [LU-5, "ENGINE OIL"](#).
6. Install the RH engine under cover.

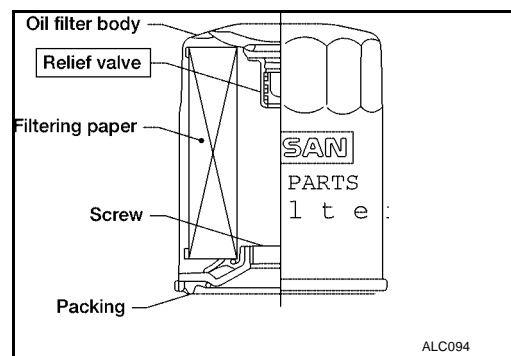

OIL PUMP

PFP:15010

Removal and Installation

EBS00CGH

- When installing the oil pump, apply clean engine oil to the rotor.
 - Make sure that O-ring seal is fitted properly.
 - Use a scraper to remove the old sealant from the mating surface of the front cover.
 - Also remove all traces of the old sealant from the mating surface of the engine block.
1. Remove the drive belts.
 2. Remove the oil pan. Refer to [EM-18, "Removal"](#) .
 3. Remove the oil strainer.
 4. Remove the front cover. Refer to [EM-43, "Removal"](#) .
 5. Install the front cover, applying a continuous bead of Genuine RTV Silicone Sealant or equivalent to mating surface of front cover assembly. Refer to [LU-2, "LIQUID GASKET APPLICATION PROCEDURE"](#) .
 6. Installation is in the reverse order of removal.

Disassembly and Assembly

EBS00CGI

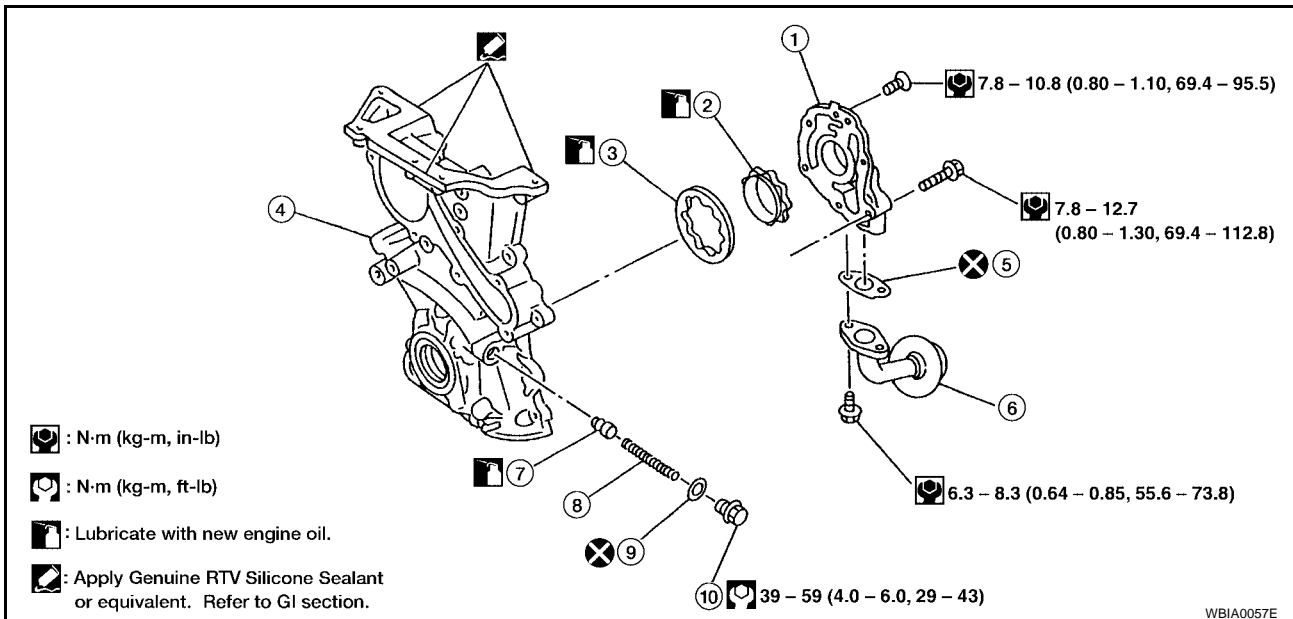

- | | | |
|--------------------|----------------|-----------------|
| 1. Oil pump cover | 2. Inner rotor | 3. Outer rotor |
| 4. Front cover | 5. Gasket | 6. Oil strainer |
| 7. Regulator valve | 8. Spring | 9. Washer |
| 10. Plug | | |

Inspection

EBS00CGJ

- Install the oil pump rotors with the punch marks on the oil pump cover side, as shown.

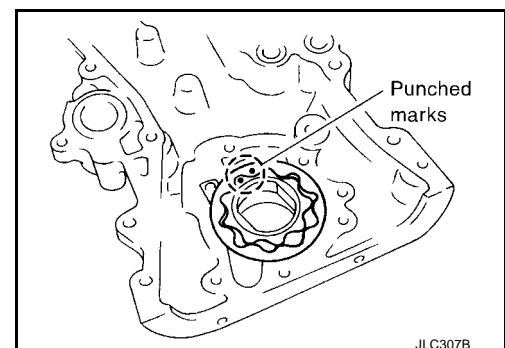

OIL PUMP

[QG18DE]

- Using a feeler gauge, check the following clearances.

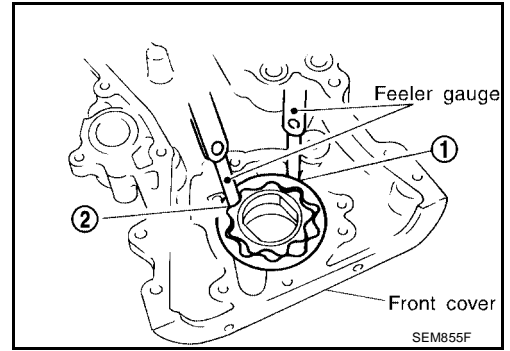

Standard clearance:

Unit: mm (in)

Body to outer rotor radial clearance 1	0.114 - 0.200 (0.0045 - 0.0079)
Inner rotor to outer rotor tip clearance 2	Below 0.18 (0.0071)
Body to inner rotor clearance 3	0.030 - 0.070 (0.0012 - 0.0028)
Body to outer rotor axial clearance 4	0.030 - 0.090 (0.0012 - 0.0035)
Inner rotor to brazed portion of housing clearance 5	0.045 - 0.091 (0.0018 - 0.0036)

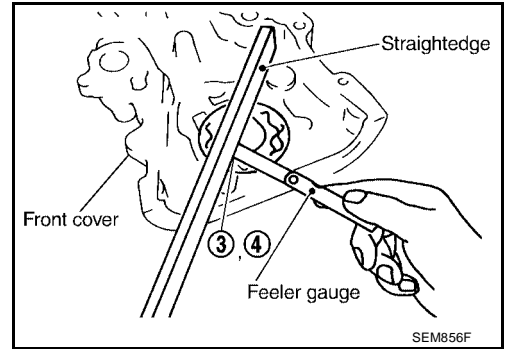

- If the tip clearance (2) exceeds the limit, replace the rotor set.
- If the body to rotor clearances (1, 3, 4, 5) exceed the limit, replace the front cover assembly.

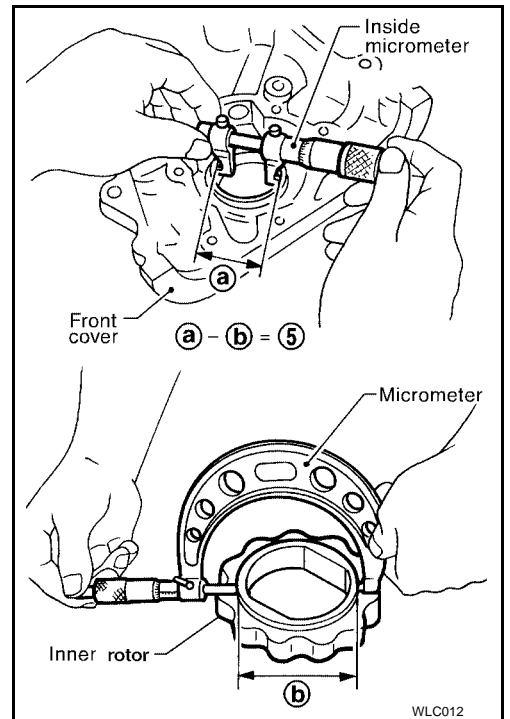

Regulator Valve Inspection

1. Visually inspect components for wear and damage.
2. Check oil pressure regulator valve sliding surface and valve spring.
3. Coat regulator valve with engine oil.
 - Check that the regulator valve falls smoothly into the valve hole by its own weight and gravity.
 - If damaged, replace the regulator valve set or front cover assembly.

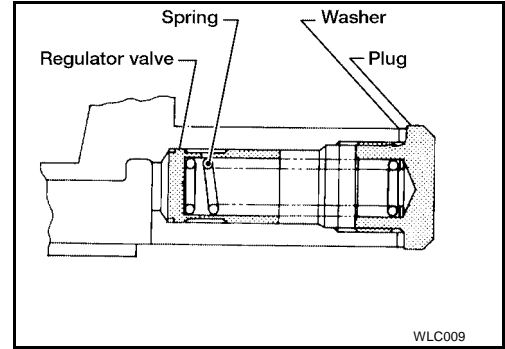

4. Check regulator valve to front cover clearance.

Clearance : 0.040 - 0.097 mm (0.0016 - 0.0038 in)

- If the valve exceeds the specification, replace the front cover assembly.

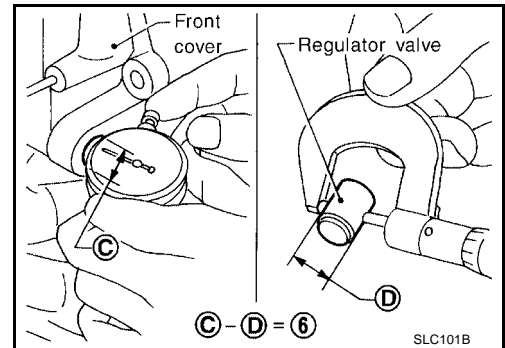

SERVICE DATA AND SPECIFICATIONS (SDS)

[QG18DE]

SERVICE DATA AND SPECIFICATIONS (SDS)

PF0:00030

Oil Pressure

EBS00CGL

Engine speed (rpm)	Approximate discharge pressure kPa (kg/cm ² , psi)
Idle speed	Approx. 98 (1.0, 14) or more
2,000	Approx. 294 (3.0, 43) or more
6,000	Approx. 392 (4.0, 57) or more

Oil Pump

EBS00CGM

Unit: mm (in)

Body to outer rotor radial clearance	0.114 - 0.200 (0.0045 - 0.0079)
Inner rotor to outer rotor tip clearance	Below 0.18 (0.0071)
Body to inner rotor clearance	0.030 - 0.070 (0.0012 - 0.0028)
Body to outer rotor axial clearance	0.030 - 0.090 (0.0012 - 0.0035)
Inner rotor to brazed portion of housing clearance	0.045 - 0.091 (0.0018 - 0.0036)

Regulator Valve

EBS00CGN

Unit: mm (in)

Regulator valve to oil pump cover clearance	0.040 - 0.097 (0.0016 - 0.0038)
---	---------------------------------

Oil Capacity

EBS00EYQ

Unit: ℓ (US qt., Imp qt.)

With oil filter change	2.7 (2-7/8, 2-3/8)
Without oil filter change	2.5 (2-5/8, 2-1/4)
Dry engine (engine overhaul)	3.1 (3-1/4, 2-3/4)

PRECAUTIONS

Precautions for Liquid Gasket

REMOVAL OF LIQUID GASKET SEALING

- After removing the mounting bolts and nuts, disconnect and remove the sealant using a seal cutter.

CAUTION:

Be careful not to damage the mating surfaces.

- In areas where the cutter is difficult to use, use a plastic hammer to lightly tap the areas where the sealant is applied.

CAUTION:

If for some unavoidable reason a tool such as a flat-bladed screwdriver is used, be careful not to damage the mating surfaces.

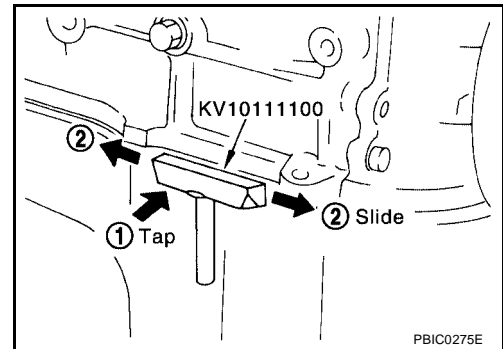

LIQUID GASKET APPLICATION PROCEDURE

- Using a scraper, remove the old sealant adhering to the gasket application surface and the mating surface.
 - Remove the old sealant completely from the groove of the gasket application surface, mounting bolts, and bolt holes.
- Clean the mating surface to remove dirt, moisture, grease, and foreign material.
- Attach the sealant tube to the tube presser.

Use Genuine RTV Silicone Sealant or equivalent. Refer to [GI-46. "RECOMMENDED CHEMICAL PRODUCTS AND SEALANTS"](#).

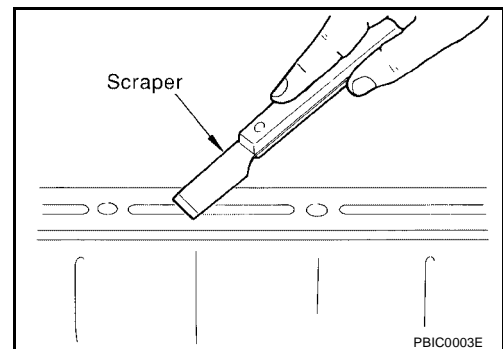

- Apply the sealant without breaks to the specified location with the specified dimensions.
 - If there is a groove for the sealant application, apply the Sealant to the groove.
 - As for the bolt holes, normally apply the sealant inside the holes. Occasionally, it should be applied outside the holes.

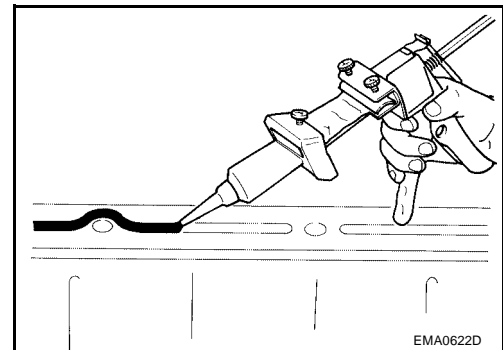

- Within five minutes of sealant application, install the mating component.
- If the sealant protrudes, wipe it off immediately.
- Do not retighten after the installation.
- After 30 minutes or more have passed after installation, fill the engine with oil and coolant.

CAUTION:

If there are specific instructions in the service manual, observe them.

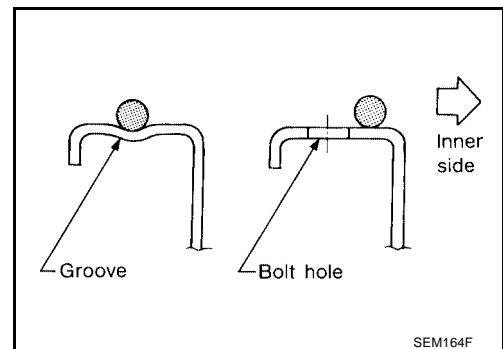

PREPARATION

[QR25DE]

PF0:00002

EBS00CGP

PREPARATION

Special Service Tools

The actual shape of Kent-Moore tools may differ from those of special service tools illustrated here.

Tool number Tool name	Description
ST25051001 (J34301-1) Oil pressure gauge	Measuring oil pressure Maximum measuring range: 2,452 kPa (25 kg/cm², 356 psi)
ST25052000 (J34301-2) Hose	Adapting oil pressure gauge to cylinder block
KV10115801 (J37140-A) Oil filter wrench	Removing and installing oil filter
WS39930000 (-) Tube presser	Pressing the tube of RTV Silicone Sealant

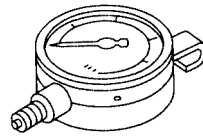

S-NT050

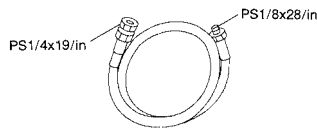

S-NT559

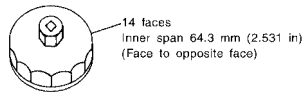

S-NT772

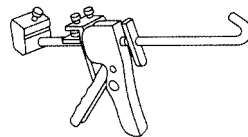

S-NT052

A

LU

C

D

E

F

G

H

I

J

K

L

M

LUBRICATION SYSTEM

Lubrication Circuit

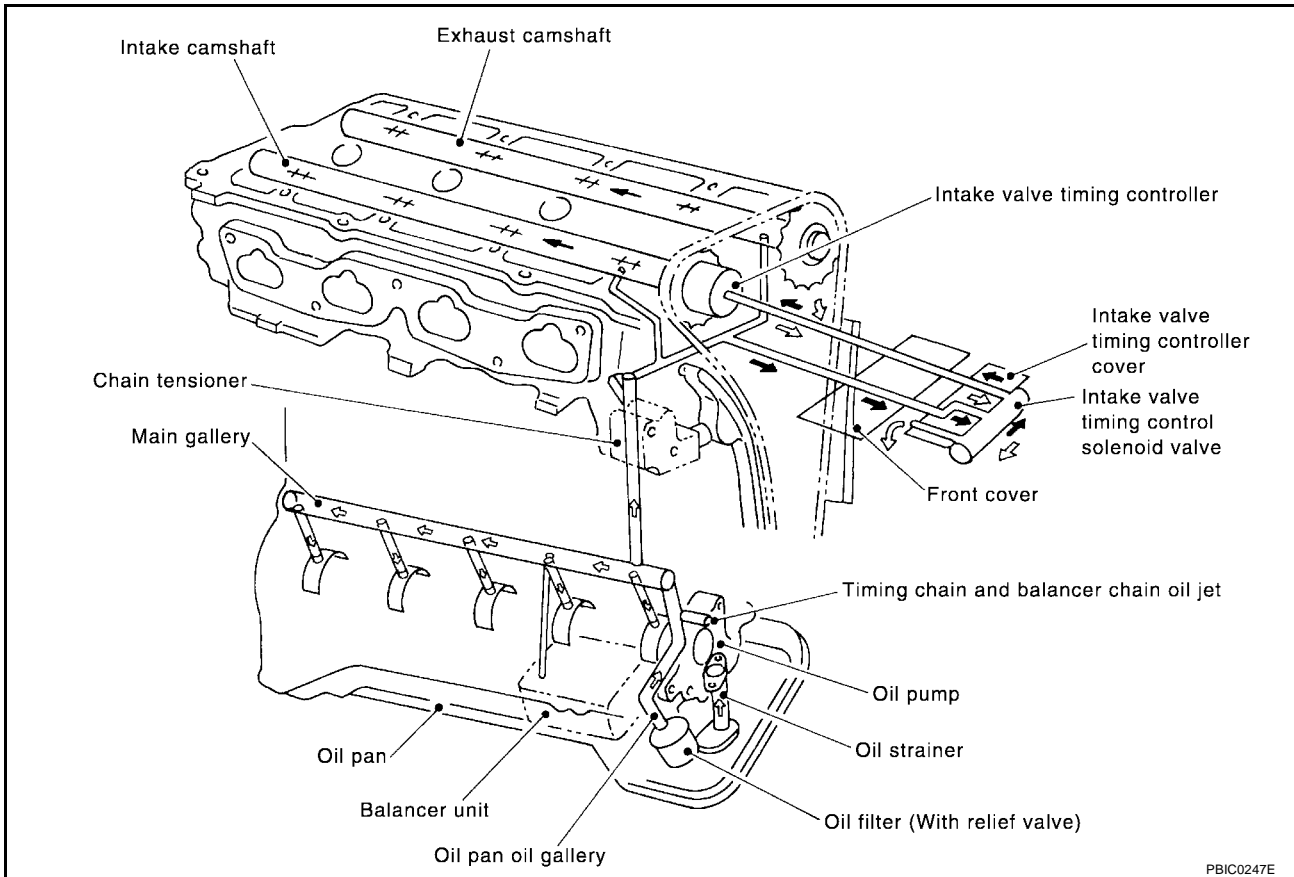

LUBRICATION SYSTEM

[QR25DE]

System Drawing

EBS00CGR

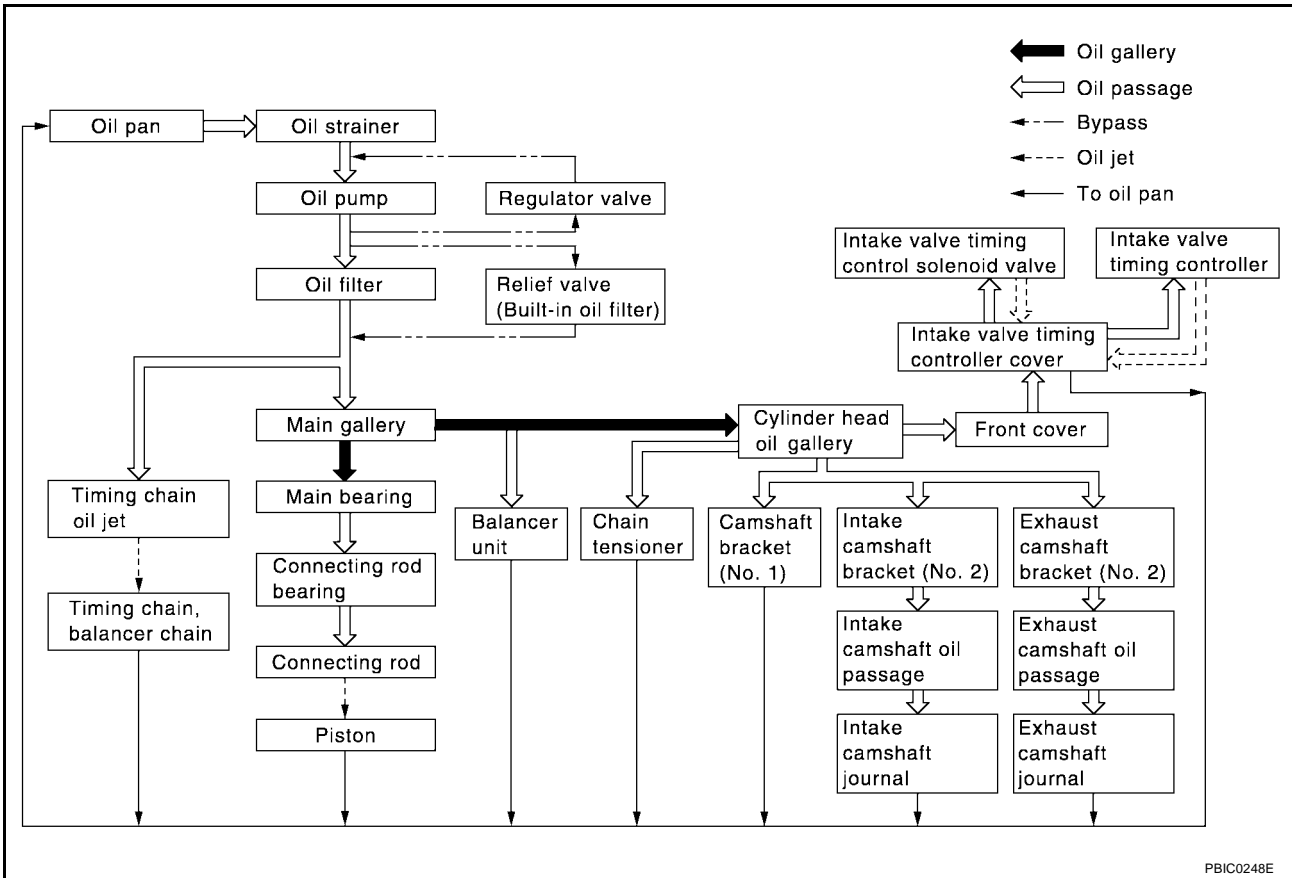

A

LU

C

D

E

F

G

H

I

J

K

L

M

ENGINE OIL

Inspection

OIL LEVEL AND MUDINESS

- Ensure the vehicle is on a level surface with engine off, then check the oil level. If the engine is already started, stop it and allow 10 minutes before checking.
- Check that the oil level is within the range shown in the figure and adjust if necessary.
- If it is out of range, add oil as necessary. Refer to [MA-13, "RECOMMENDED FLUIDS AND LUBRICANTS"](#) .
- Check the oil for white turbidity or remarkable contamination.
- If the oil becomes turbid and white, it is highly probable that it is contaminated with coolant. Diagnose the problem and correct as necessary.

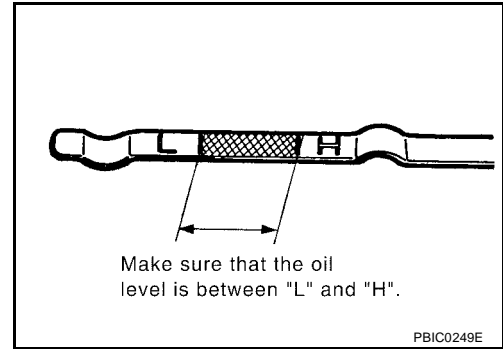

OIL LEAKAGE

Check for oil leakage around the following areas.

- Oil pan
- Oil pan drain plug
- Oil pressure switch
- Oil filter
- IVTC (intake valve timing control) cover
- Front cover
- Mating surface between cylinder block and cylinder head
- Mating surface between cylinder head and rocker cover
- Crankshaft oil seal

OIL PRESSURE CHECK

WARNING:

- **Be careful not to burn yourself, as the engine oil may be hot.**
 - **For M/T models, put gearshift lever in Neutral position. For A/T models, put selector lever in Park "P" position.**
1. Check the oil level.
 2. Remove the under cover.
 3. Remove the oil pressure switch to connect the oil pressure gauge.
 4. After warming up the engine to the normal operating temperature, check that oil pressure corresponding to the engine speed is produced.

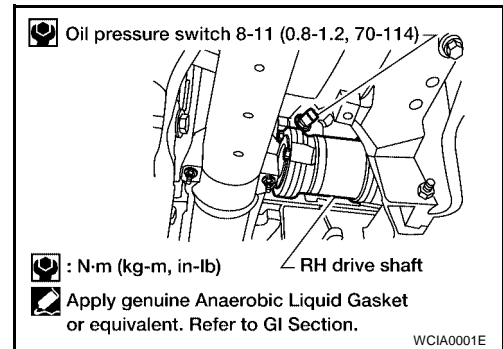

Engine oil pressure [Oil temperature is 80 °C (176 °F)]

Engine speed (rpm)	Idle speed	2,000	6,000
Engine pressure kPa (kg/cm ² , psi)	Approx. 98 (1.0, 14) or more	Approx. 294 (3.0, 43) or more	Approx. 392 (4.0, 57) or more

5. After checking, install the oil pressure switch as follows:
 - a. Remove the old thread sealant adhering to the switch and engine.
 - b. Apply thread sealant. Tighten the switch to specification.
Use Genuine High Performance Thread Sealant or equivalent. Refer to [GI-46, "RECOMMENDED CHEMICAL PRODUCTS AND SEALANTS"](#) .

Oil pressure switch : 12.3 - 17.2 N·m (1.25 - 1.75 kg·m, 10 - 12 ft·lb)

Changing Engine Oil

WARNING:

- Be careful not to burn yourself, as the engine oil is hot.
 - Prolonged and repeated contact with used engine oil may cause skin cancer: try to avoid direct skin contact with used oil. If skin contact is made, wash thoroughly with soap or hand cleaner as soon as possible.
1. Warm up engine, and check for oil leakage from engine components.
 2. Stop the engine and wait for 10 minutes.
 3. Remove the oil drain plug and oil filler cap to drain the oil.
 4. Remove the oil filter and replace it with a new oil filter.
 5. Install the oil drain plug using a new washer.

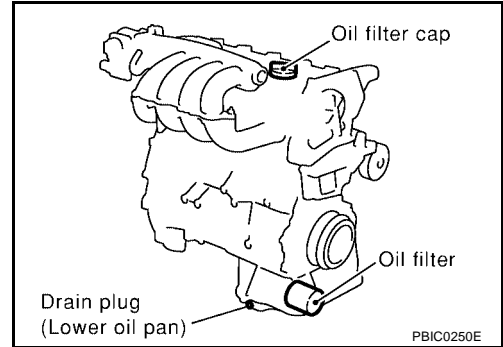

Oil pan drain plug : 29 - 39 N-m (3.0 - 4.0 kg-m, 22 - 29 ft-lb)

CAUTION:

- Clean the oil drain plug and install with a new washer.
6. Fill the engine with the specified oil.
 - Refer to [MA-13, "RECOMMENDED FLUIDS AND LUBRICANTS"](#) .
- Oil capacity (Approximate):

Drain and refill	With oil filter change	4.0 ℓ (4-1/4 US qt, 3-1/2 Imp qt)
	Without oil filter change	3.8 ℓ (4 US qt, 3-3/8 Imp qt)
Dry engine (engine overhaul)		4.5 ℓ (4-3/4 US qt, 4 Imp qt)

- The refill capacity depends on the oil temperature and drain time. Use these specifications for reference only.
 - Always use the dipstick to determine when the proper amount of oil is in the engine.
7. Warm up the engine and check the area around the oil drain plug and oil filter for oil leakage.
 8. Stop the engine and wait for 10 minutes.
 9. Check the oil level using the dipstick. Refer to [LU-16, "ENGINE OIL"](#) .

OIL FILTER

Removal and Installation

REMOVAL

1. Open the oil filter installation/removal access cover on the RH engine under cover.
2. Using an oil filter wrench, remove the oil filter.

CAUTION:

- Be careful not to get burned when the engine and engine oil are hot.
- When removing, prepare a shop cloth to absorb any oil leakage or spillage.
- Do not allow engine oil to adhere to the drive belts.
- Completely wipe off any oil that adheres to the engine and the vehicle.

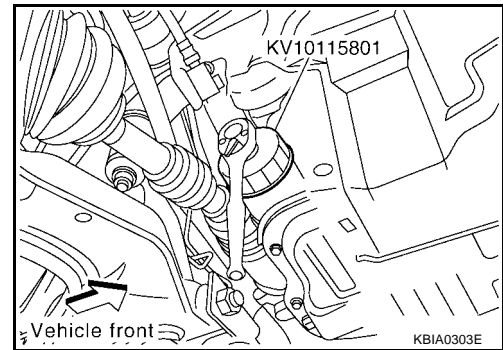

INSTALLATION

1. Remove foreign material adhering to the oil filter installation surface.
2. Apply a thin coating of engine oil to the oil seal surface of the new oil filter.

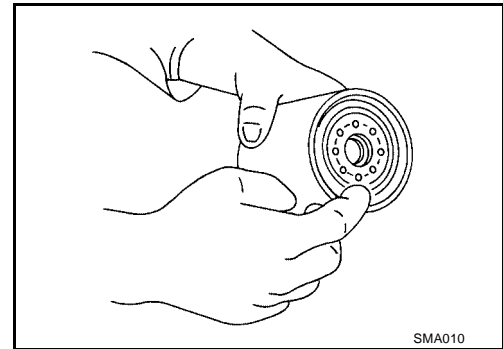

3. Screw the oil filter manually until it touches the installation surface and then tighten it by 2/3 turn. Or tighten the oil filter to the correct specification.

Oil filter : 14.7 - 20.5 N·m (1.5 - 2.1 kg·m, 11 - 15 ft·lb)

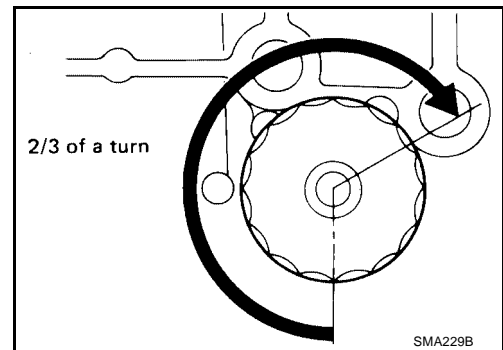

4. After warming up the engine, check for engine oil leakage.
5. Check the oil level and adjust the engine oil level as necessary. Refer to [LU-16, "ENGINE OIL"](#).

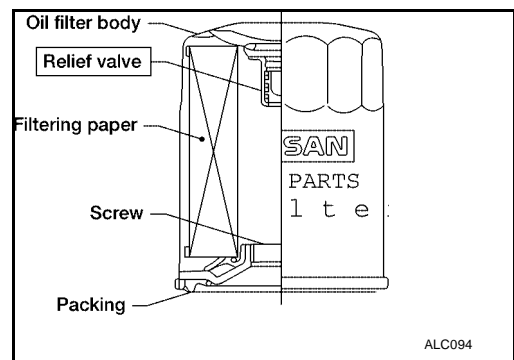

OIL PUMP

Removal and Installation

1. To remove the oil pump, remove the front cover. Refer to [EM-136, "TIMING CHAIN"](#).
 - Only perform the steps necessary to remove the front cover.
2. Installation is in the reverse order of removal.

Disassembly and Assembly

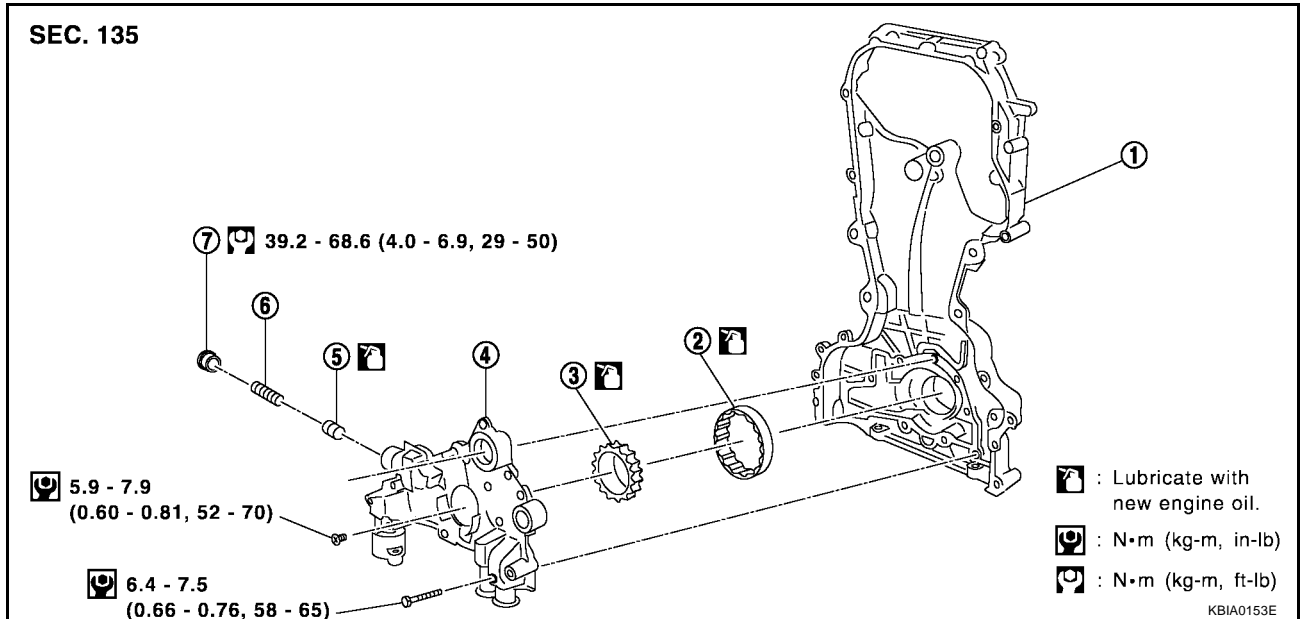

- | | | |
|-------------------|--------------------|---------------------------|
| 1. Front cover | 2. Outer rotor | 3. Inner rotor |
| 4. Oil pump cover | 5. Regulator valve | 6. Regulator valve spring |
| 7. Regulator plug | | |

CAUTION:

Before installation, apply new engine oil to the parts as instructed in the figure.

DISASSEMBLY

1. Remove the oil pump cover.
2. Remove the inner rotor and the outer rotor from the front cover.
3. After removing the regulator plug, remove the regulator valve spring and the regulator valve.

INSPECTION AFTER DISASSEMBLY

1. Measuring the internal clearance of the oil pump components.
 - Measure the clearance with a feeler gauge.

Clearance between outer rotor and oil pump body (position 1):

Standard : 0.114 - 0.179 mm (0.0045 - 0.0070 in) clearance

Tip clearance between inner rotor and outer rotor (position 2):

Standard : Less than 0.220 mm (0.0087 in) clearance

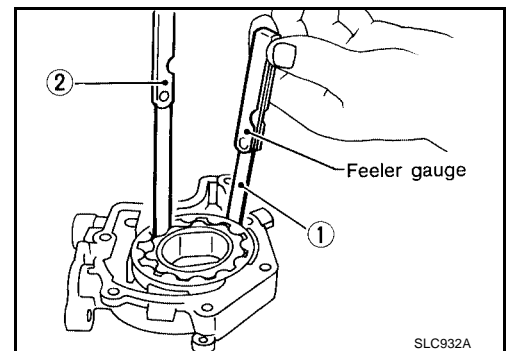

OIL PUMP

[QR25DE]

- Measure clearance with feeler gauge and straightedge. Side clearance between inner rotor and oil pump body (position 3):

**Standard clearance : 0.030 - 0.070 mm
(0.0012 - 0.0028 in)**

- Side clearance between outer rotor and oil pump body (position 4):

**Standard clearance : 0.060 - 0.110 mm
(0.0024 - 0.0043 in)**

- Calculate the clearance between inner rotor and oil pump body as follows.

2. Measure the outer diameter of protruded portion of inner rotor (Position 5).

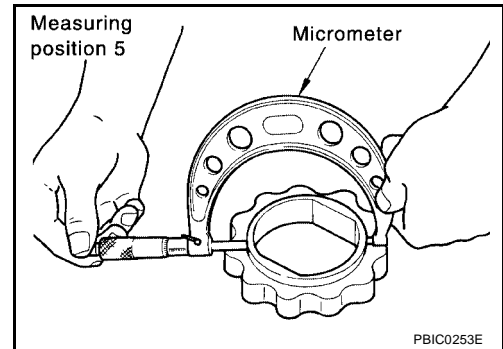
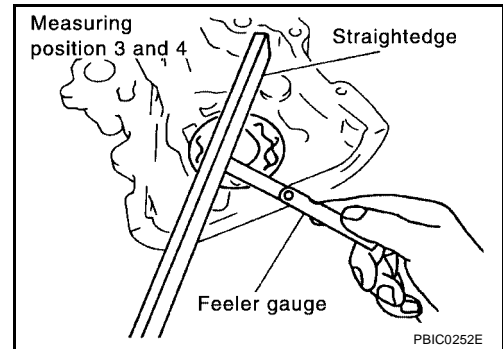

3. Measure the inner diameter of oil pump body with an inside micrometer (Position 6).

(Clearance) = (Inner diameter of oil pump body) – (Outer diameter of inner rotor):

**Standard clearance : 0.035 - 0.070 mm
(0.0014 - 0.0028 in)**

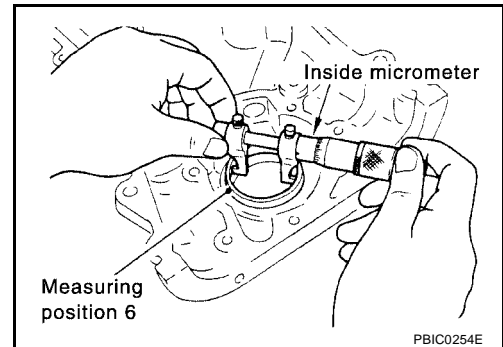

4. Measure the regulator valve clearance.

- (Clearance) = D1 (Valve hole diameter) – D2 (Outer diameter of valve):

**Standard clearance : 0.040 - 0.097 mm
(0.0016 - 0.0038 in)**

CAUTION:

Coat the regulator valve with engine oil.

Check that it falls smoothly into the valve hole by its own weight.

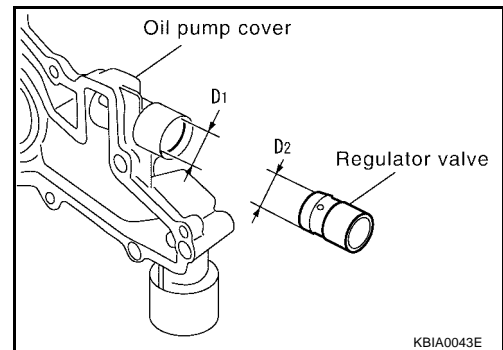

OIL PUMP

[QR25DE]

ASSEMBLY

- Assembly is in the reverse order of disassembly.
- Install the inner rotor and outer rotor with the punched marks on the oil pump cover side.

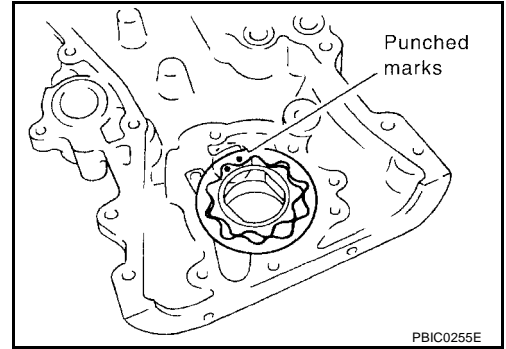

A

LU

C

D

E

F

G

H

I

J

K

L

M

SERVICE DATA AND SPECIFICATIONS (SDS)

[QR25DE]

SERVICE DATA AND SPECIFICATIONS (SDS)

PFP:00030

Oil Pressure

EBS00CGX

Engine speed (rpm)	Approximate discharge pressure kPa (kg/cm ² , psi)
Idle speed	Approx. 98 (1.0, 14) or more
2,000	Approx. 294 (3.0, 43) or more
6,000	Approx. 392 (4.0, 57) or more

Oil Pump

EBS00CGY

Unit: mm (in)

Body to outer rotor radial clearance	0.114 - 0.179 (0.0045-0.0070)
Inner rotor to outer rotor tip clearance	Less than 0.220 (0.0087)
Body to inner rotor axial clearance	0.030 - 0.070 (0.0012 - 0.0028)
Body to outer rotor axial clearance	0.060 - 0.110 (0.0024 - 0.0043)
Inner rotor to brazed portion of housing clearance	0.035 - 0.070 (0.0014 - 0.0028)

Regulator Valve

EBS00CGZ

Unit: mm (in)

Regulator valve to oil pump cover clearance	0.040 - 0.097 (0.0016 - 0.0038)
---	---------------------------------

Oil Capacity

EBS00CH0

Unit: ℓ (US qt., Imp qt.)

With oil filter change	Approximately 4.0 (4-1/4, 3-1/2)
Without oil filter change	Approximately 3.8 (4, 3-3/8)
Dry engine (engine overhaul)	Approximately 4.5 (4-3/4, 4)