

SECTION **DI**

DRIVER INFORMATION SYSTEM

CONTENTS

<b>PRECAUTION</b> .....	<b>3</b>	INSPECTION/VEHICLE SPEED SENSOR .....	21	A
Precautions for Supplemental Restraint System (SRS) "AIR BAG" and "SEAT BELT PRE-TENSIONER" .....	3	INSPECTION/ENGINE REVOLUTION SIGNAL..	22	B
Wiring Diagrams and Trouble Diagnosis .....	3	INSPECTION/FUEL LEVEL SENSOR UNIT AND FUEL PUMP .....	23	C
<b>METERS AND GAUGES</b> .....	<b>4</b>	INSPECTION/WATER TEMPERATURE GAUGE .....	25	D
Component Parts and Harness Connector Location...	4	Electrical Components Inspection .....	26	E
System Description .....	5	FUEL LEVEL SENSOR UNIT CHECK .....	26	F
UNIFIED CONTROL METER .....	5	VEHICLE SPEED SENSOR SIGNAL CHECK ...	26	G
HOW TO CHANGE THE DISPLAY FOR ODO/TRIP METER (WITHOUT TRIP COMPUTER) .....	5	Removal and Installation of Combination Meter ...	26	H
HOW TO CHANGE THE DISPLAY FOR ODO/TRIP METER (WITH TRIP COMPUTER) .....	5	<b>WARNING LAMPS</b> .....	<b>27</b>	I
POWER SUPPLY AND GROUND CIRCUIT .....	6	Schematic .....	27	J
WATER TEMPERATURE GAUGE .....	6	WITHOUT TACHOMETER .....	27	
TACHOMETER .....	6	WITH TACHOMETER .....	28	
FUEL GAUGE .....	6	Wiring Diagram — WARN — .....	29	
SPEEDOMETER .....	6	WITHOUT TACHOMETER .....	29	
CAN Communication System Description .....	6	WITH TACHOMETER (QG18DE MODELS) .....	32	
Combination Meter .....	7	WITH TACHOMETER (QR25DE MODELS) .....	36	DI
WITHOUT TACHOMETER .....	7	Electrical Components Inspection .....	40	
WITH TACHOMETER (QG18DE MODELS) .....	8	FUEL WARNING LAMP OPERATION CHECK...	40	L
QR25DE .....	9	OIL PRESSURE SWITCH CHECK .....	40	
Schematic .....	10	DIODE CHECK .....	40	
WITHOUT TACHOMETER .....	10	<b>WARNING CHIME</b> .....	<b>41</b>	M
WITH TACHOMETER (QG18DE MODELS) .....	11	Component Parts and Harness Connector Location..	41	
WITH TACHOMETER (QR25DE MODELS) .....	12	System Description .....	42	
Wiring Diagram — METER — .....	13	WITHOUT POWER DOOR LOCKS .....	42	
WITHOUT TACHOMETER .....	13	WITH POWER DOOR LOCKS .....	42	
WITH TACHOMETER (QG18DE MODELS) .....	14	Wiring Diagram — CHIME — .....	44	
WITH TACHOMETER (QR25DE MODELS) .....	15	WITHOUT POWER DOOR LOCKS .....	44	
Meter/Gauge Operation and Odo/Trip Meter Segment Check in Diagnosis Mode .....	16	WITH POWER DOOR LOCKS .....	45	
SELF-DIAGNOSIS FUNCTION .....	16	CONSULT-II Function (BCM) .....	46	
HOW TO ALTERNATE DIAGNOSIS MODE .....	16	CONSULT-II BASIC OPERATION PROCEDURE (WITH POWER DOOR LOCKS) .....	46	
Trouble Diagnoses .....	17	CONSULT-II Application Items (With Power Door Locks) .....	47	
PRELIMINARY CHECK .....	17	"KEY WARN ALARM" .....	47	
SYMPTOM CHART .....	18	"LIGHT WARN ALM" .....	47	
POWER SUPPLY AND GROUND CIRCUIT CHECK .....	18	"SEAT BELT ALM" .....	47	
		Trouble Diagnoses (Without Power Door Locks) ...	48	
		SYMPTOM CHART .....	48	

POWER SUPPLY AND GROUND CIRCUIT CHECK .....	48
DIAGNOSTIC PROCEDURE 1 (LIGHTING SWITCH INPUT SIGNAL CHECK) .....	49
DIAGNOSTIC PROCEDURE 2 (KEY SWITCH INSERT SIGNAL CHECK) .....	49
DIAGNOSTIC PROCEDURE 3 (SEAT BELT BUCKLE SWITCH LH CHECK) .....	50
DIAGNOSTIC PROCEDURE 4 .....	51
Trouble Diagnoses (With Power Door Locks) .....	53
SYMPTOM CHART .....	53
POWER SUPPLY AND GROUND CIRCUIT CHECK .....	53
DIAGNOSTIC PROCEDURE 1 (LIGHTING SWITCH INPUT SIGNAL CHECK) .....	54
DIAGNOSTIC PROCEDURE 2 (KEY SWITCH INSERT SIGNAL CHECK) .....	55
DIAGNOSTIC PROCEDURE 3 (SEAT BELT BUCKLE SWITCH LH CHECK) .....	56
DIAGNOSTIC PROCEDURE 4 .....	57

<b>BOARD COMPUTER .....</b>	<b>60</b>
System Description .....	60
FUNCTION .....	60
OUTSIDE AIR TEMPERATURE INDICATION .....	60
DTE (DISTANCE TO EMPTY) INDICATION .....	60
TRIP DISTANCE .....	60
TRIP TIME .....	60
AVERAGE FUEL CONSUMPTION .....	60
AVERAGE VEHICLE SPEED .....	60
HOW TO CHANGE/RESET INDICATION .....	60
CAN Communication System Description .....	61
Wiring Diagram — B/COMP — .....	62
Trouble Diagnoses .....	63
SEGMENT CHECK .....	63
PRELIMINARY CHECK .....	63
DIAGNOSIS PROCEDURE .....	63
Electrical Components Inspection .....	64
AMBIENT SENSOR .....	64

# PRECAUTION

## PRECAUTION

PF0:00011

### Precautions for Supplemental Restraint System (SRS) “AIR BAG” and “SEAT BELT PRE-TENSIONER”

EKS00BNX

The Supplemental Restraint System such as “AIR BAG” and “SEAT BELT PRE-TENSIONER”, used along with a front seat belt, helps to reduce the risk or severity of injury to the driver and front passenger for certain types of collision. Information necessary to service the system safely is included in the SRS and SB section of this Service Manual.

#### **WARNING:**

- To avoid rendering the SRS inoperative, which could increase the risk of personal injury or death in the event of a collision which would result in air bag inflation, all maintenance must be performed by an authorized NISSAN/INFINITI dealer.
- Improper maintenance, including incorrect removal and installation of the SRS, can lead to personal injury caused by unintentional activation of the system. For removal of Spiral Cable and Air Bag Module, see the SRS section.
- Do not use electrical test equipment on any circuit related to the SRS unless instructed to in this Service Manual. SRS wiring harnesses can be identified by yellow and/or orange harnesses or harness connectors.

### Wiring Diagrams and Trouble Diagnosis

EKS00BXP

When you read wiring diagrams, refer to the following:

- Refer to [GI-15, "How to Read Wiring Diagrams"](#) .
- Refer to [PG-3, "POWER SUPPLY ROUTING"](#) for power distribution circuit.

When you perform trouble diagnosis, refer to the following:

- Refer to [GI-11, "HOW TO FOLLOW TEST GROUPS IN TROUBLE DIAGNOSES"](#) .
- Refer to [GI-27, "How to Perform Efficient Diagnosis for an Electrical Incident"](#) .

A  
B  
C  
D  
E  
F  
G  
H  
I  
J  
L  
M

DI

# METERS AND GAUGES

## METERS AND GAUGES

PF2:24814

### Component Parts and Harness Connector Location

EKS00399

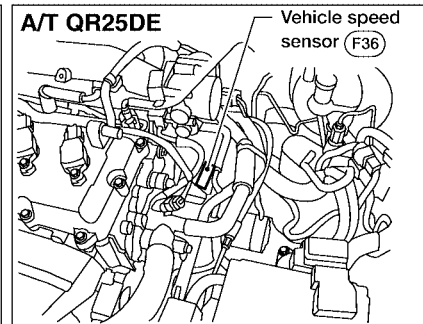
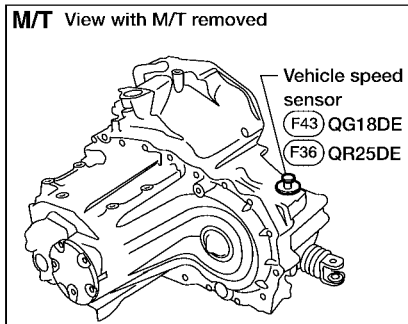
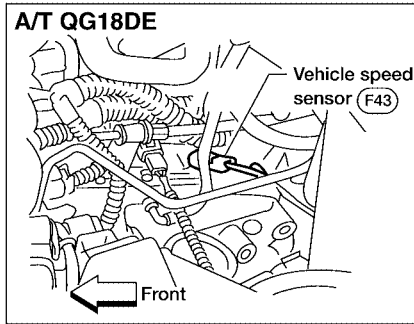
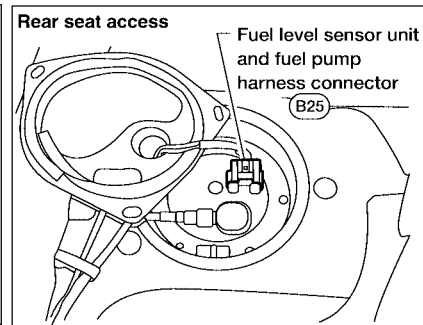
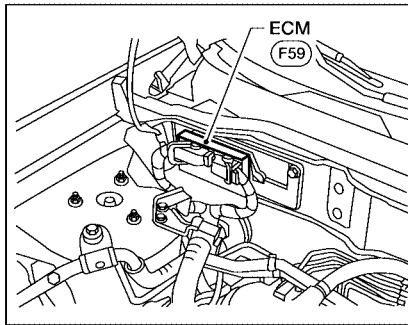
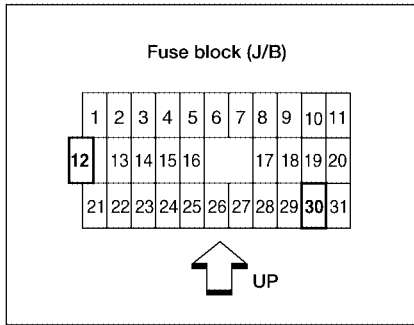

WKIA1094E

# METERS AND GAUGES

EKS0039A

## System Description UNIFIED CONTROL METER

- Speedometer, odo/trip meter, tachometer (if equipped), fuel gauge and water temperature gauge are controlled by the unified meter control unit built-in combination meter.
- Digital meter is adopted for odo/trip meter.\*  
\*The record of the odometer is kept even if the battery cable is disconnected. The record of the trip meter is erased when the battery cable is disconnected.
- Odo/trip meter segment can be checked in diagnosis mode.
- Meter/gauge can be checked in diagnosis mode.

## HOW TO CHANGE THE DISPLAY FOR ODO/TRIP METER (WITHOUT TRIP COMPUTER)

### NOTE:

Turn ignition switch to the ON position to operate odo/trip meter.

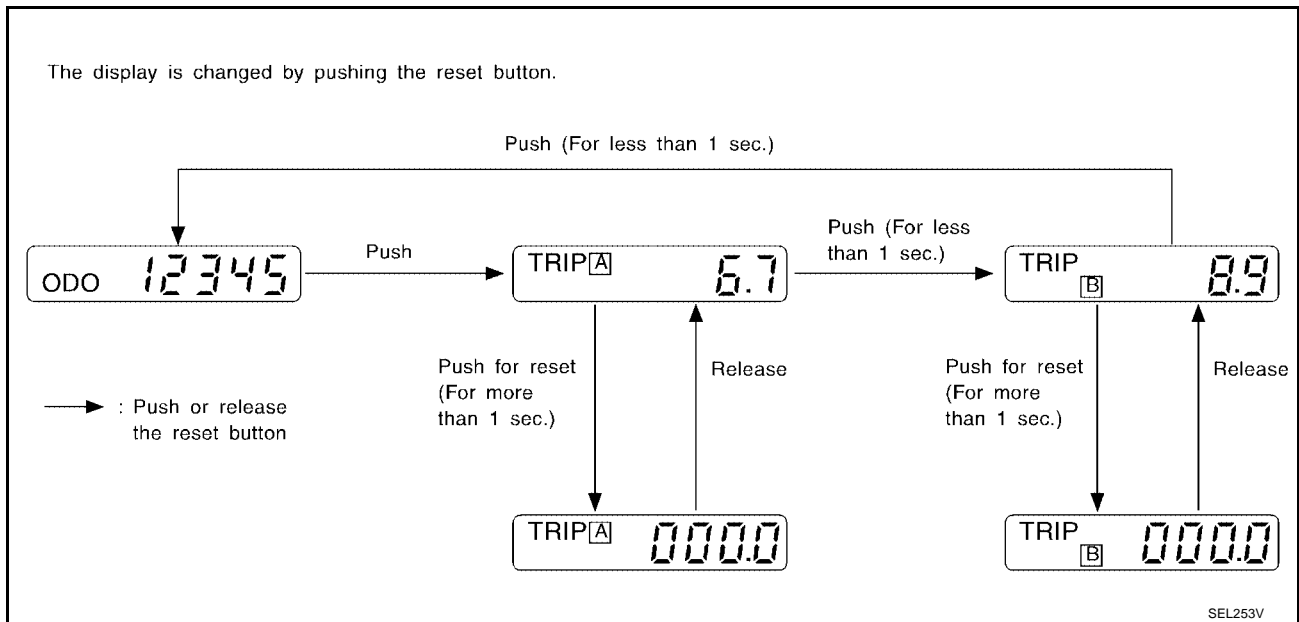

## HOW TO CHANGE THE DISPLAY FOR ODO/TRIP METER (WITH TRIP COMPUTER)

### NOTE:

Turn ignition switch to the ON position to operate odo/trip meter.

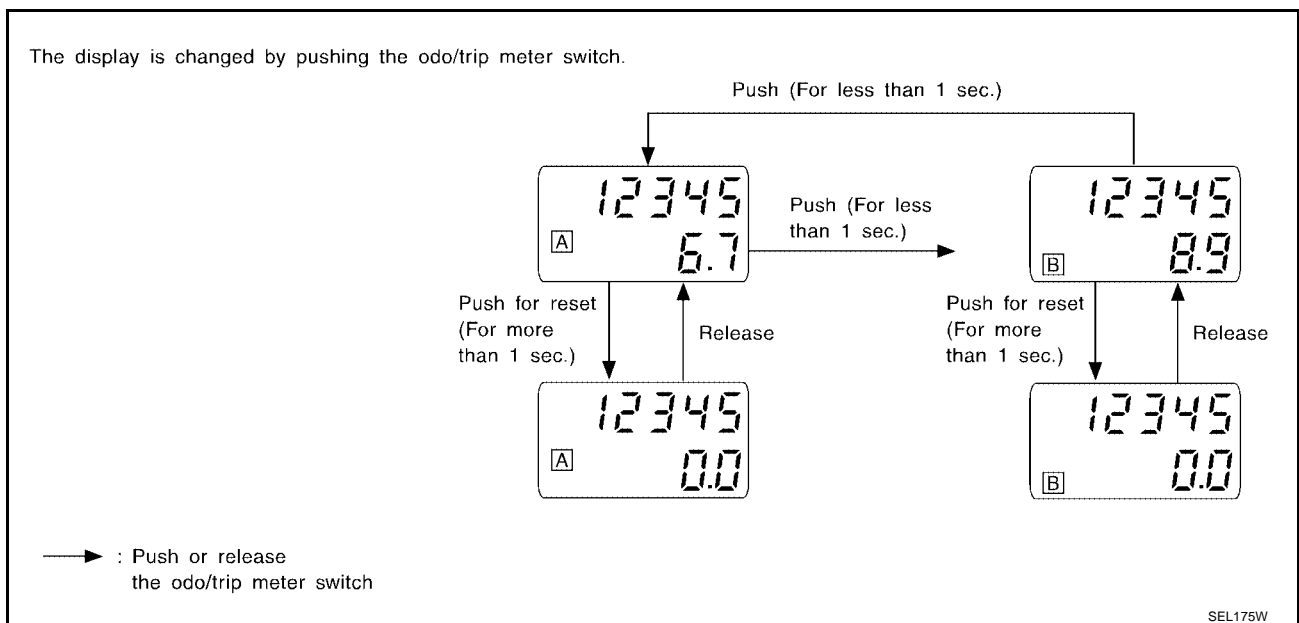

# METERS AND GAUGES

---

## POWER SUPPLY AND GROUND CIRCUIT

Power is supplied at all times:

- through 10A fuse [No. 12, located in the fuse block (J/B)]
- to combination meter terminal 25 (without tachometer), or 42 (QG18DE with tachometer), or 13 (QR25DE).

With the ignition switch in the ON or START position, power is supplied:

- through 10A fuse [No. 30, located in the fuse block (J/B)]
- to combination meter terminal 26 and 20 (without tachometer), or 41 and 6 (QG18DE with tachometer), or 14 and 7 (QR25DE).

Ground is supplied:

- to combination meter terminal 27 (without tachometer), or 48 (QG18DE with tachometer), or 12 (QR25DE)
- through body grounds M28 and M54.
- to combination meter terminal 31 (without tachometer), or 45 (QG18DE with tachometer), or 8 (QR25DE)
- through body grounds B19 and B13.

## WATER TEMPERATURE GAUGE

The water temperature gauge indicates the engine coolant temperature.

ECM provides a water temperature signal to combination meter for water temperature gauge with CAN communication line.

## TACHOMETER

The tachometer indicates engine speed in revolutions per minute (rpm).

ECM provides an engine speed signal to combination meter for tachometer with CAN communication line.

## FUEL GAUGE

The fuel gauge indicates the approximate fuel level in the fuel tank.

The fuel gauge is regulated by a variable ground signal supplied:

- to combination meter terminal 30 (without tachometer), or 44 (QG18DE with tachometer), or 21 (QR25DE) for the fuel gauge
- from terminal 2 of the fuel level sensor unit and fuel pump
- through terminal 5 of the fuel level sensor unit and fuel pump, and
- through body grounds B19 and B13.

## SPEEDOMETER

The combination meter receives a voltage signal from the vehicle speed sensor for the speedometer.

The voltage is supplied:

- to combination meter terminal 29 (without tachometer), or 47 (QG18DE with tachometer), or 17 (QR25DE) for the speedometer
- from terminal 1 (with QG18DE), or terminal + (with QR25DE) of the vehicle speed sensor.

The speedometer converts the voltage into the vehicle speed displayed.

## CAN Communication System Description

EKS003LD

Refer to [LAN-4, "CAN COMMUNICATION"](#) .

# METERS AND GAUGES

## Combination Meter WITHOUT TACHOMETER

EKS0039B

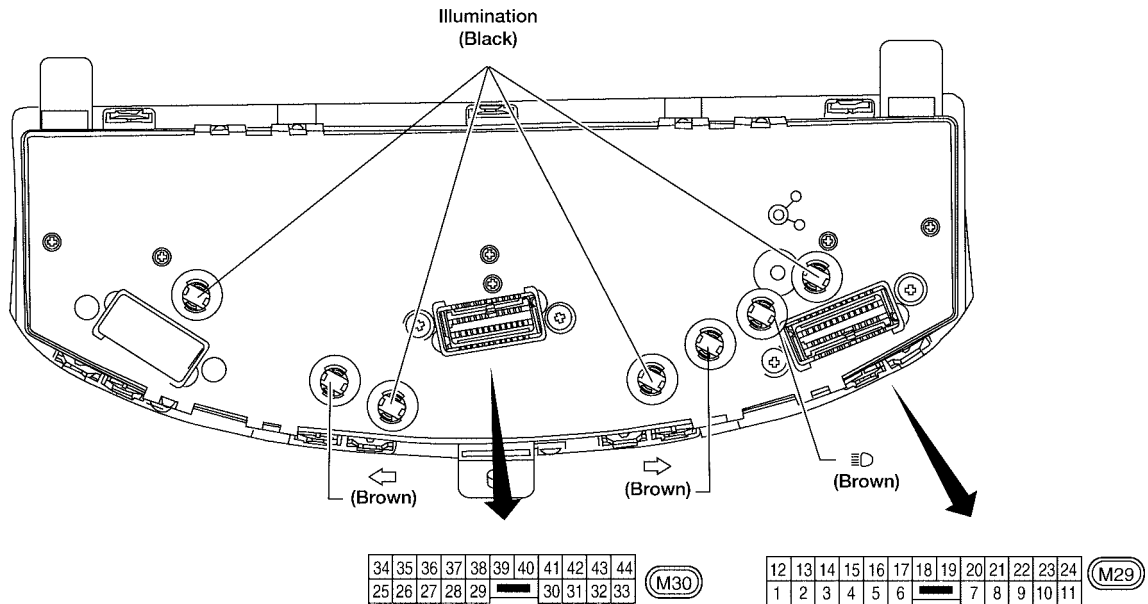
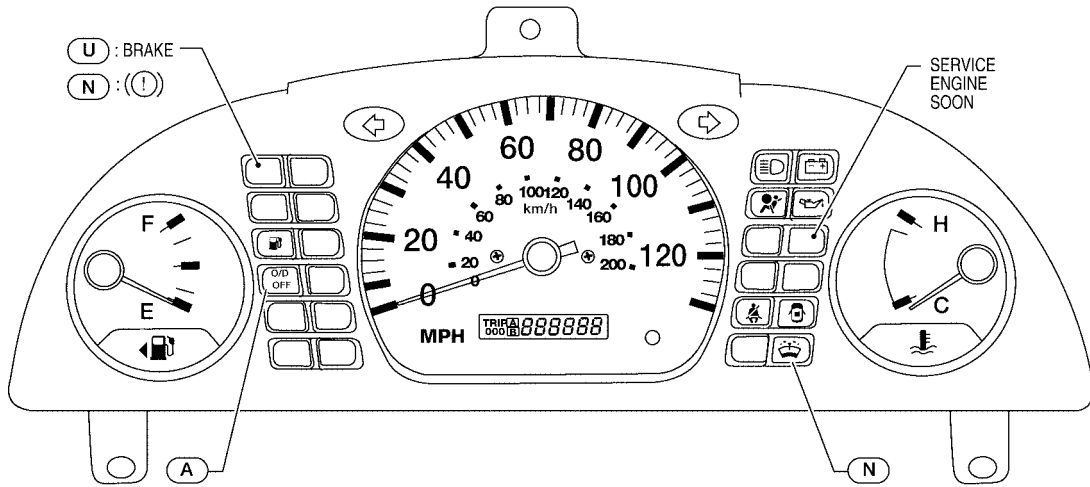

- (U) : For U.S.A
- (N) : For Canada
- (A) : With A/T

Bulb socket color	Bulb wattage
Brown	1.4W
Black	3.0W

( ) : Bulb socket color

WKIA0289E

# METERS AND GAUGES

## WITH TACHOMETER (QG18DE MODELS)

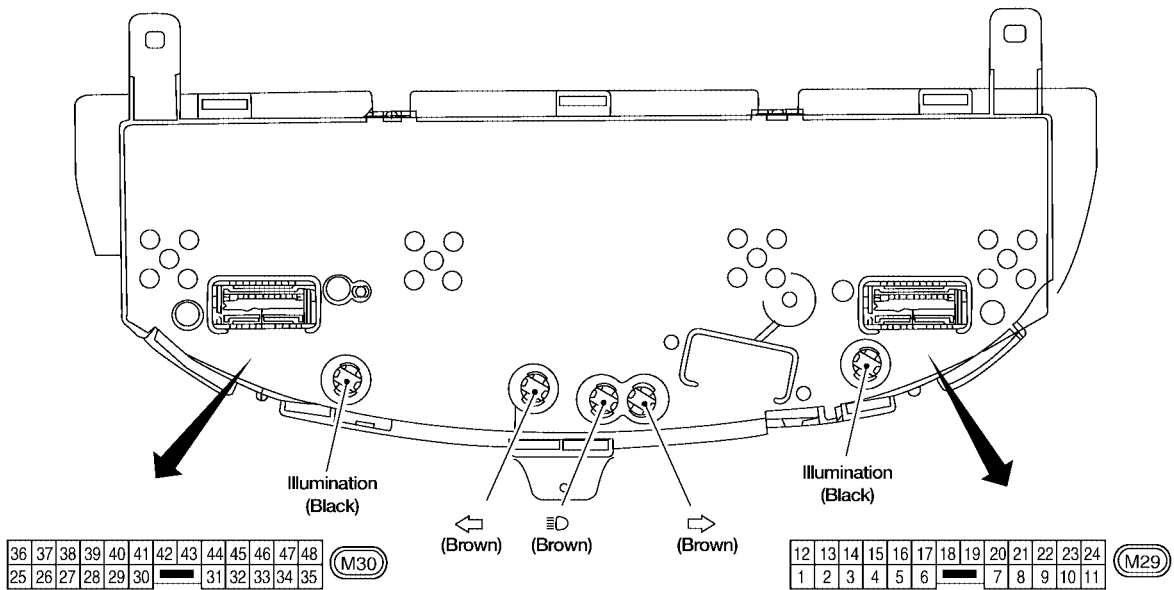
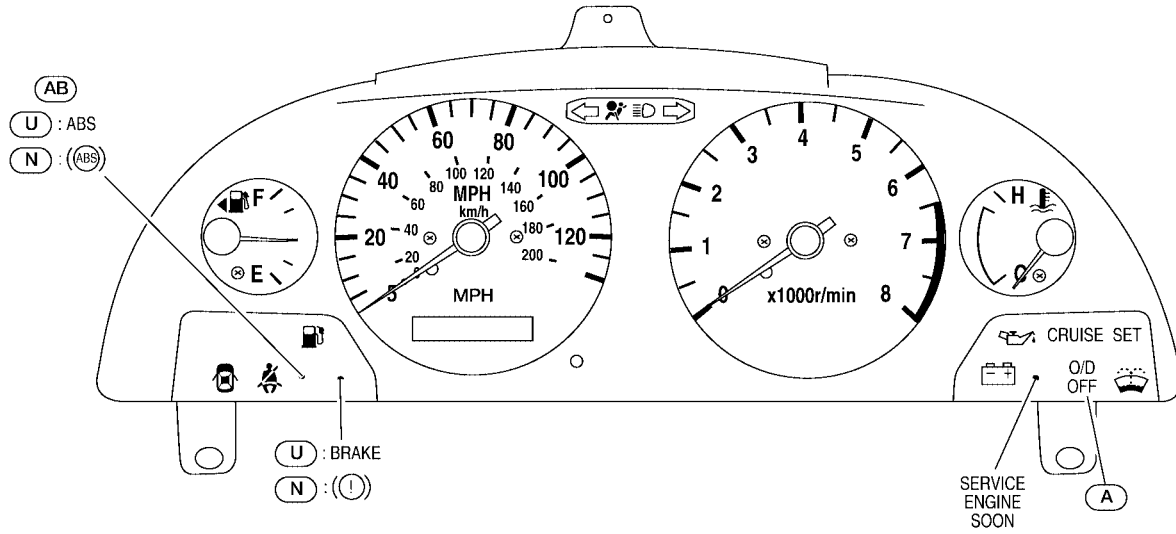

- (U) : For USA
- (N) : For Canada
- (A) : With A/T
- (AB) : With ABS

Bulb socket color	Bulb wattage
Brown	1.4W
Black	3.0W

( ) : Bulb socket color

WKIA1095E



# METERS AND GAUGES

QR25DE

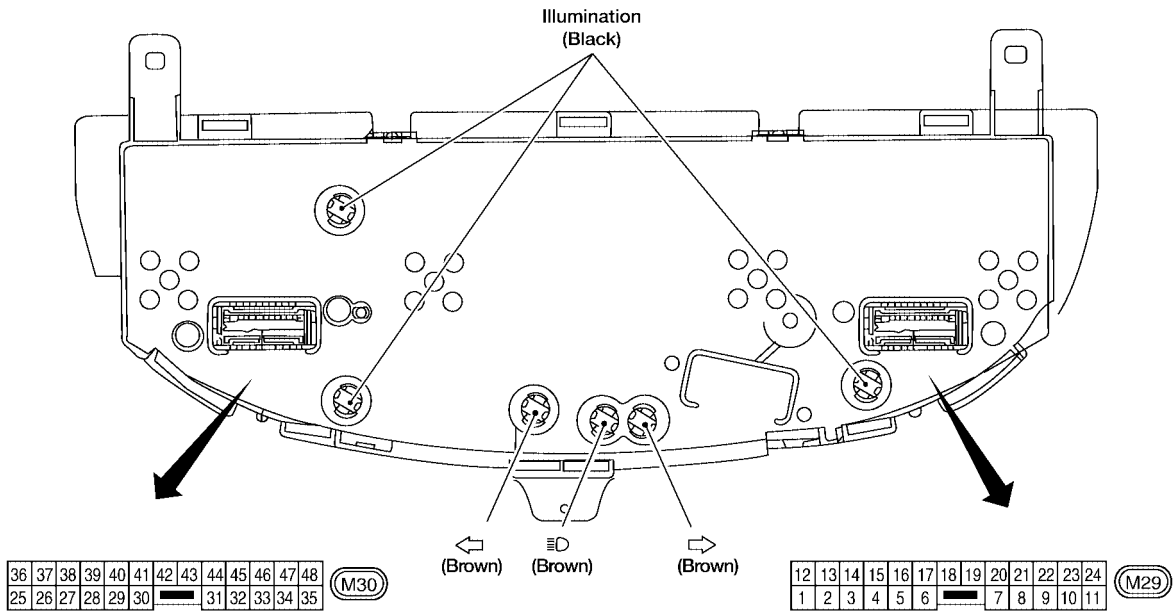
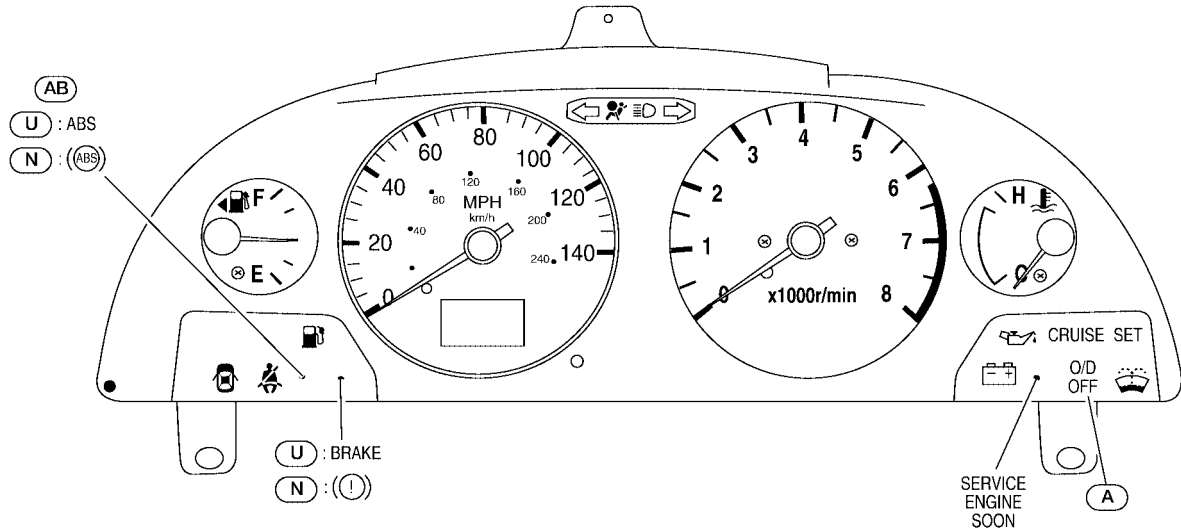

- U** : For USA
- N** : For Canada
- A** : With A/T
- AB** : With ABS

Bulb socket color	Bulb wattage
Brown	1.4W
Black	3.0W

( ) : Bulb socket color

WKIA1096E

# METERS AND GAUGES

## Schematic WITHOUT TACHOMETER

EKS0039C

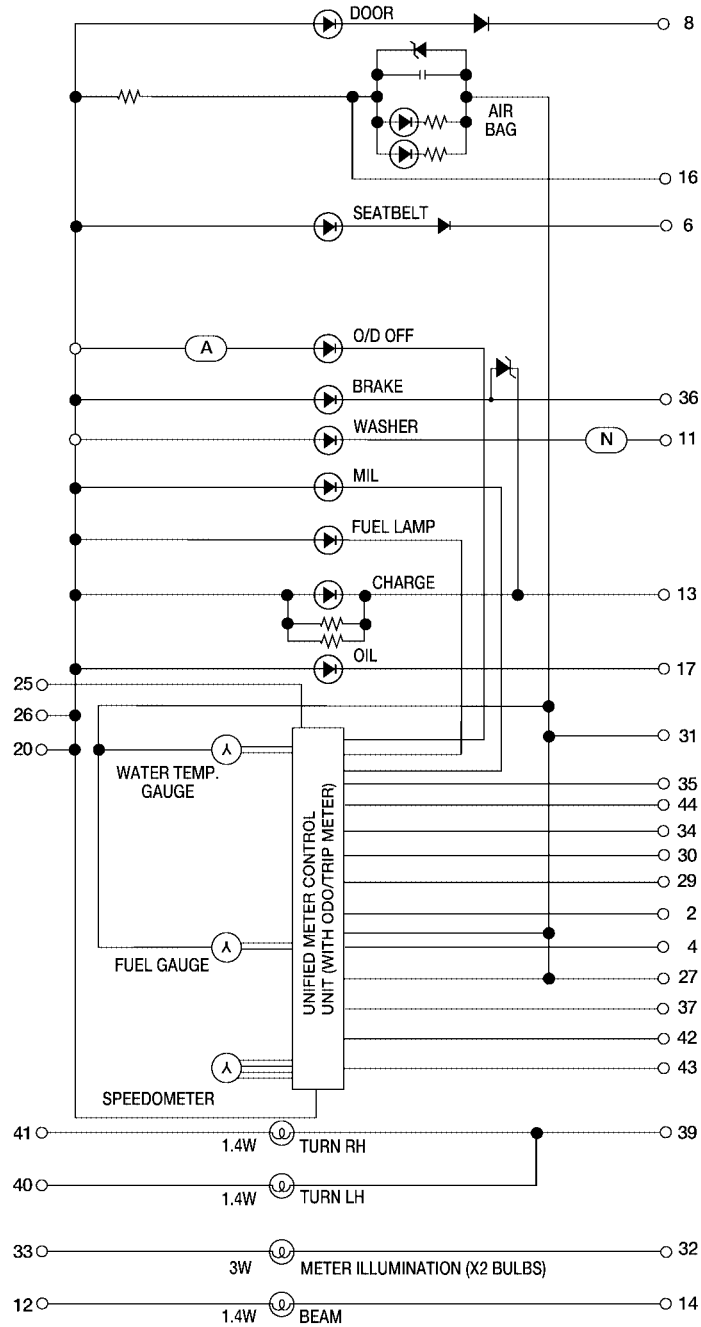

(A) : With A/T  
(N) : CANADA

WKWA0607E

# METERS AND GAUGES

## WITH TACHOMETER (QG18DE MODELS)

A  
B  
C  
D  
E  
F  
G  
H  
I  
J  
DI  
L  
M

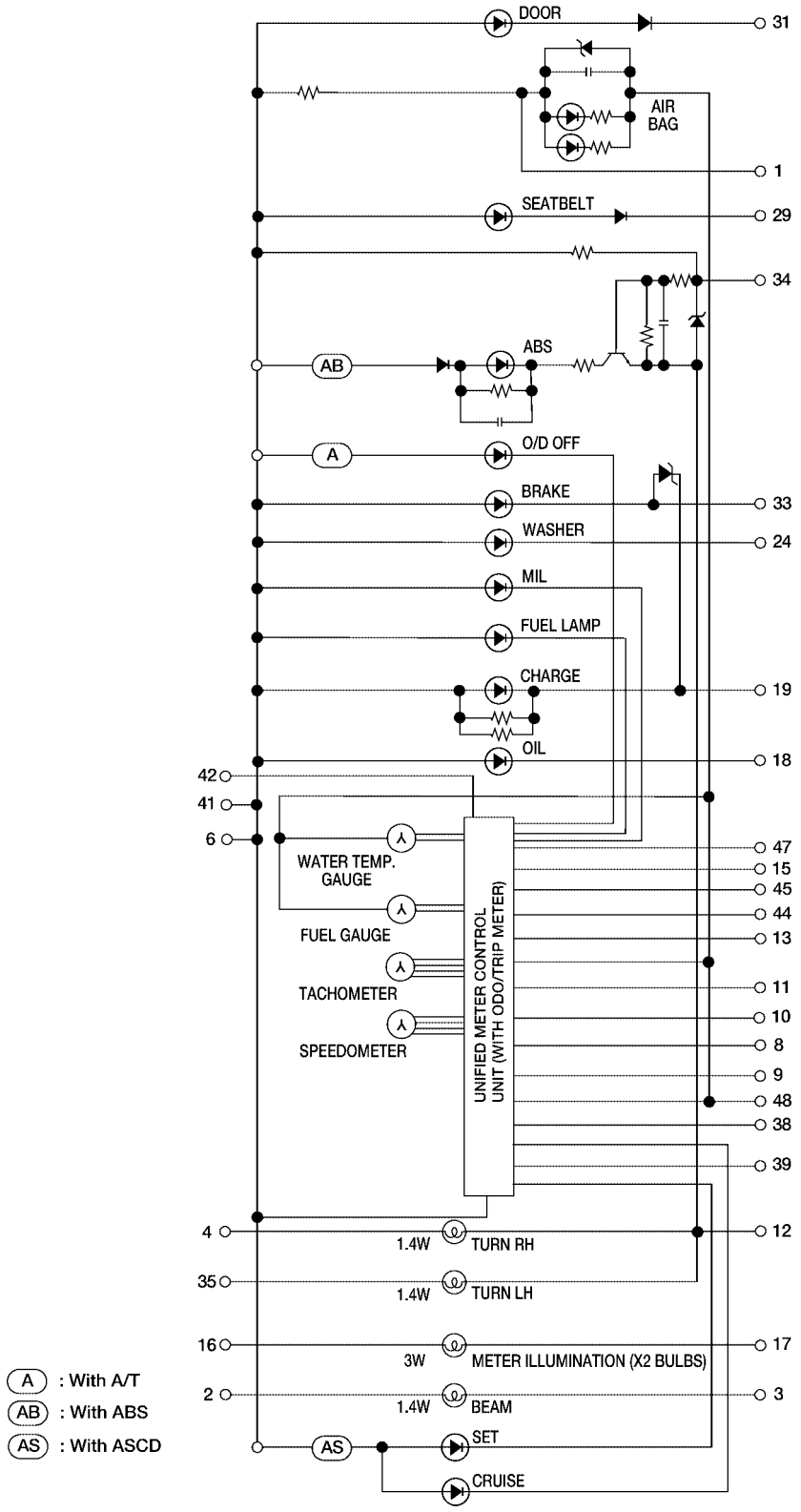

WKWA1611E

# METERS AND GAUGES

## WITH TACHOMETER (QR25DE MODELS)

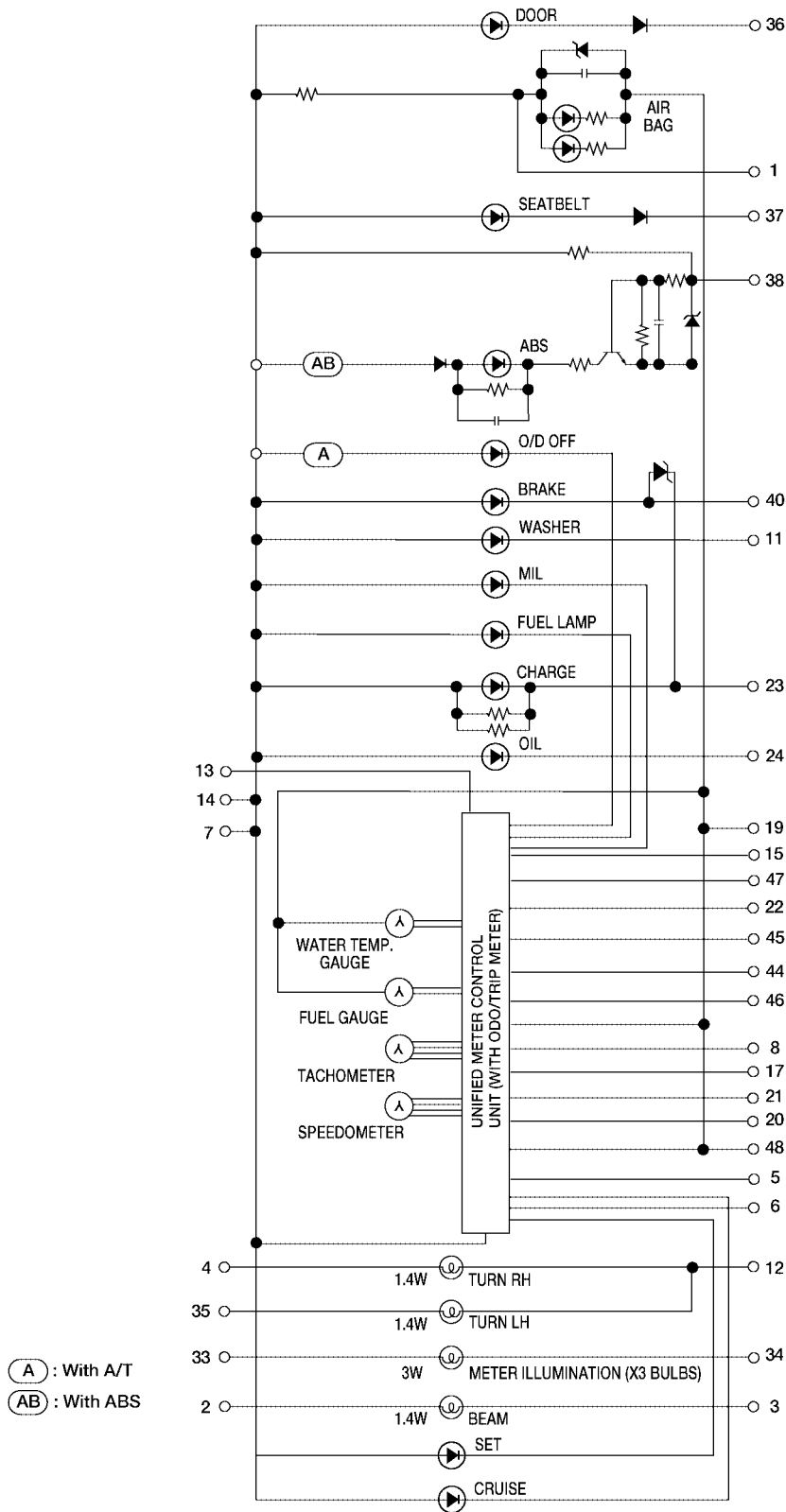

WKWA1612E

# METERS AND GAUGES

## Wiring Diagram — METER — WITHOUT TACHOMETER

EKS0039D

### DI-METER-01

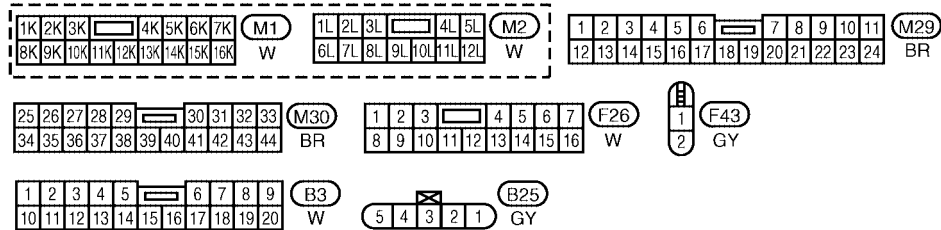
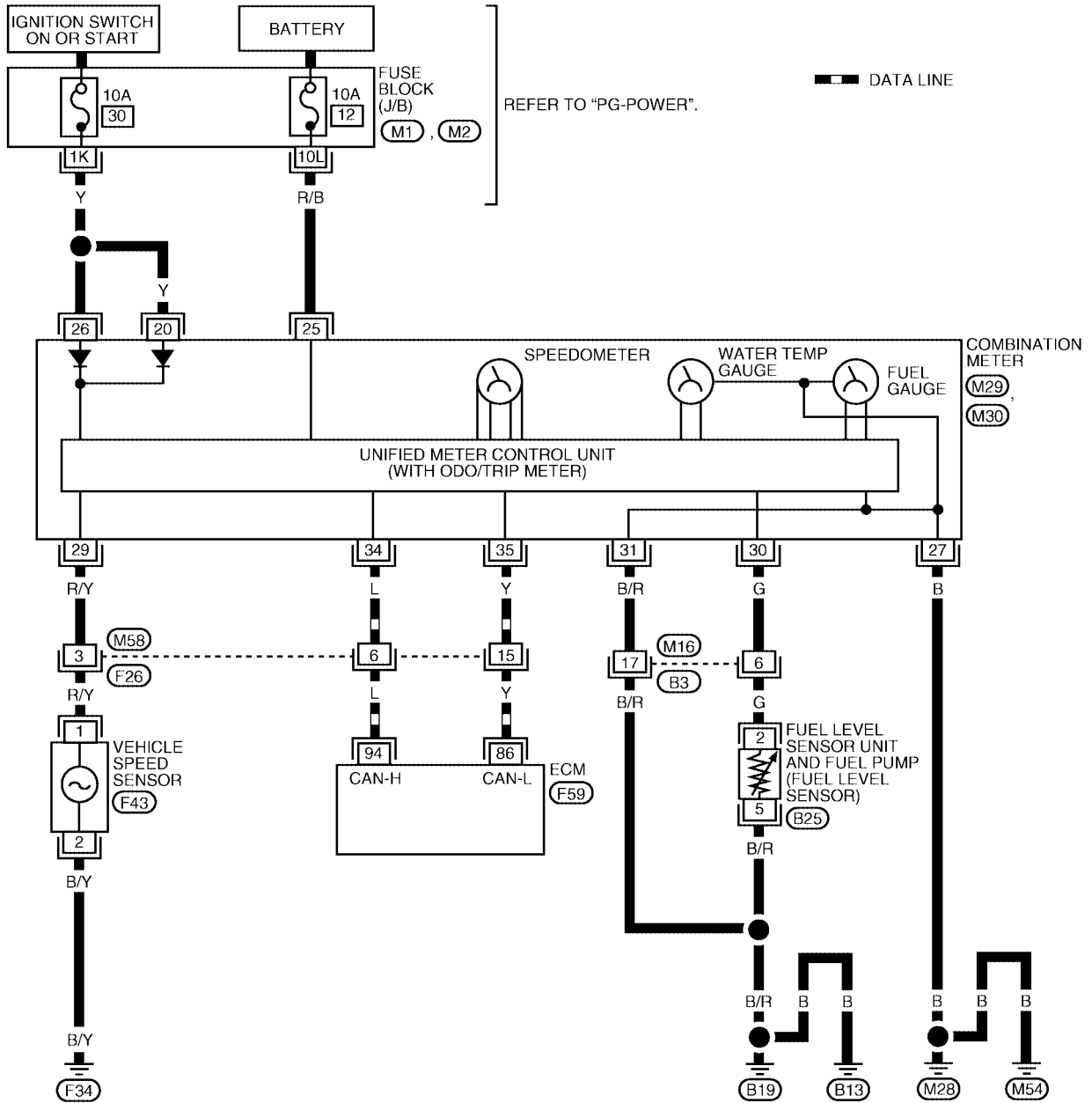

REFER TO THE FOLLOWING.  
(F59) - ELECTRICAL UNITS

WKWA1613E

# METERS AND GAUGES

## WITH TACHOMETER (QG18DE MODELS)

## DI-METER-02

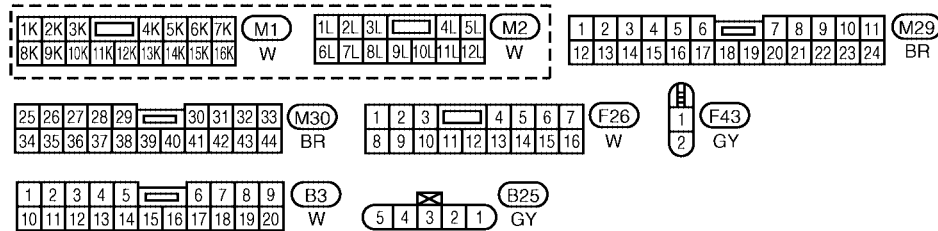
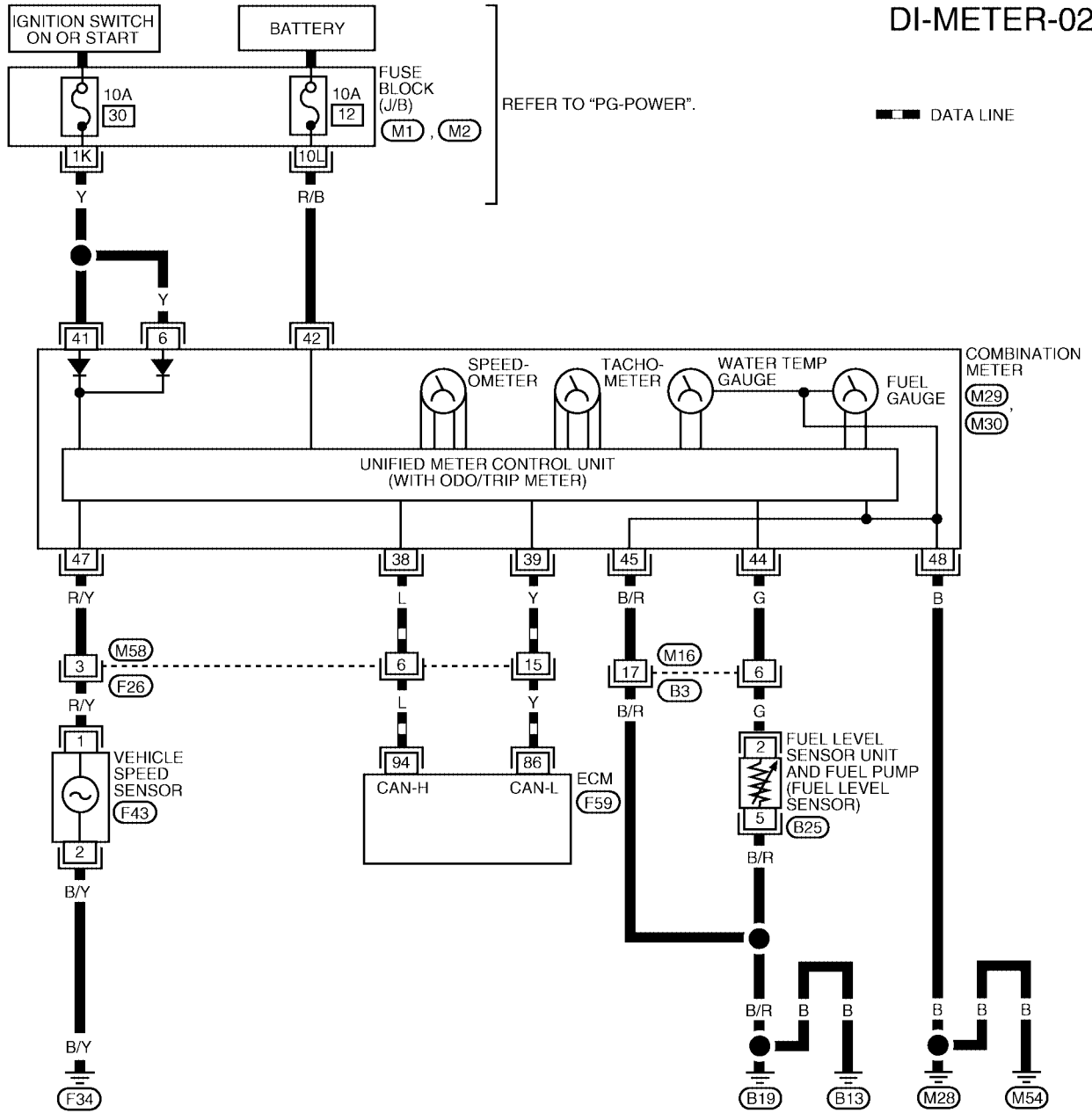

REFER TO THE FOLLOWING.  
 (F59) - ELECTRICAL UNITS

# METERS AND GAUGES

## WITH TACHOMETER (QR25DE MODELS)

DI-METER-03

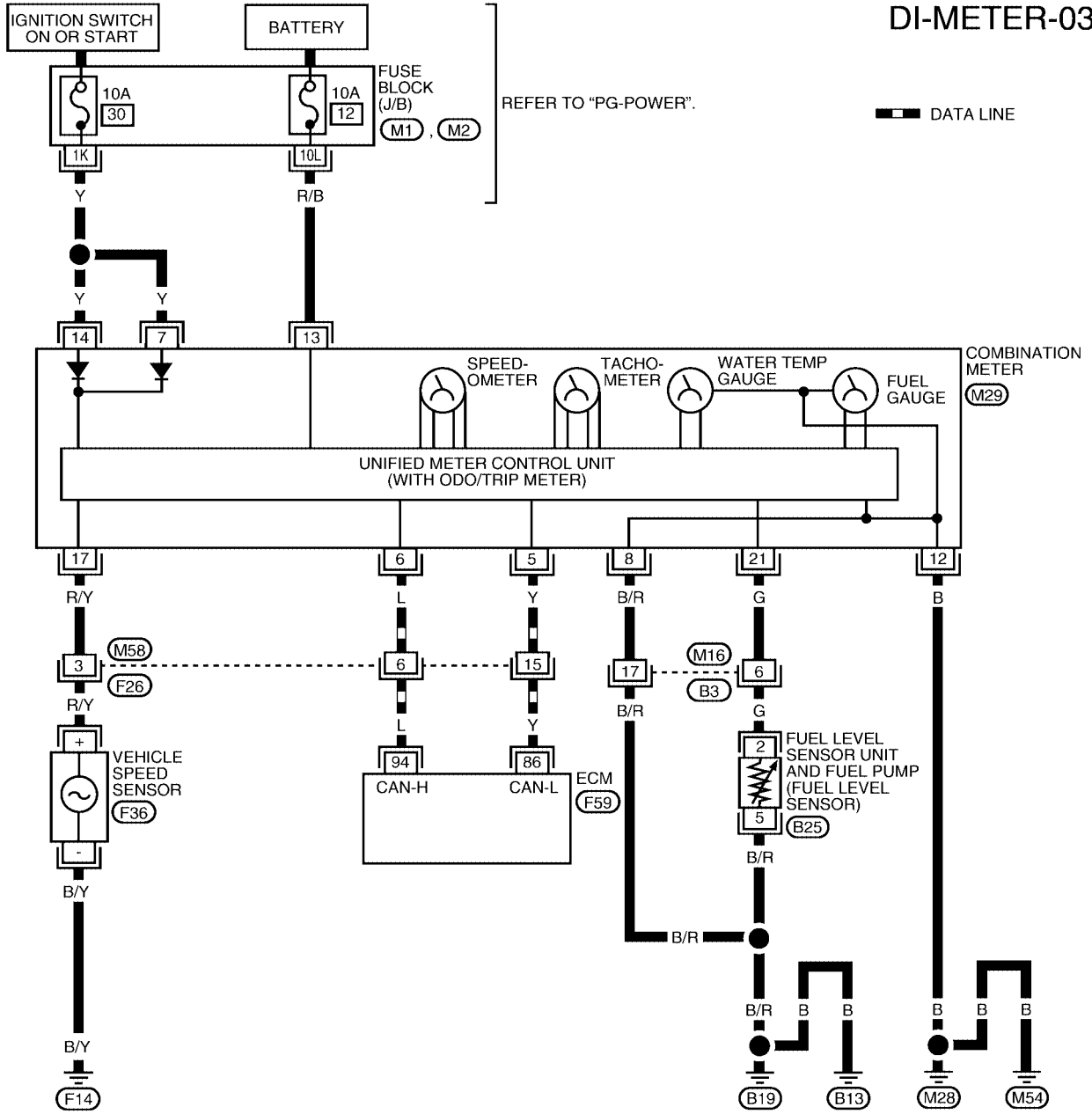

A  
B  
C  
D  
E  
F  
G  
H  
I  
J  
K  
L  
M

DI

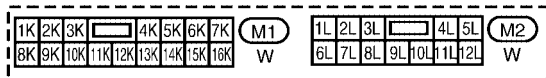

REFER TO THE FOLLOWING.  
(F59) - ELECTRICAL UNITS

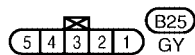
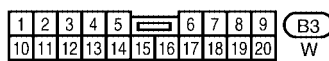
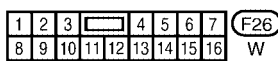

WKWA0605E

# METERS AND GAUGES

## Meter/Gauge Operation and Odo/Trip Meter Segment Check in Diagnosis Mode

EKS0039E

### SELF-DIAGNOSIS FUNCTION

- Odo/trip meter segment can be checked in diagnosis mode.
- Meters/gauges can be checked in diagnosis mode.

### HOW TO ALTERNATE DIAGNOSIS MODE

1. Turn ignition switch to ON and change odo/trip meter to "TRIP A" or "TRIP B".
2. Turn ignition switch to OFF.
3. Turn ignition switch to ON when pushing odo/trip meter switch.
4. Release odo/trip meter switch 1 second after ignition switch is turned ON.
5. Push odo/trip meter switch three times within 7 seconds.
6. All odo/trip meter segments should be turned on.

#### NOTE:

If some segments are not turned on, combination meter should be replaced.

At this point, the unified meter control unit is turned to diagnosis mode.

7. Push odo/trip meter switch. Indication of each meter/gauge should be as shown in figure while pushing odo/trip meter switch.

#### NOTE:

It takes a few seconds for indication of fuel gauge and water temperature gauge to become stable.

8. Turn ignition switch to OFF or start engine to cancel diagnosis mode.

QG18DE

TRIP A 000000  
ODO B 000000

QR25DE

000000  
A B 00.00  
ICY 00.00  
dte mpg mph

WKIA1120E

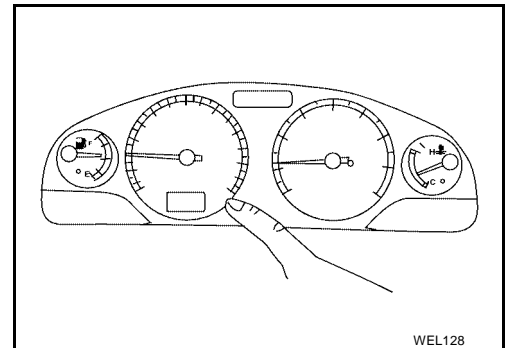

WEL128



# METERS AND GAUGES

## Trouble Diagnoses PRELIMINARY CHECK

EKS0039F

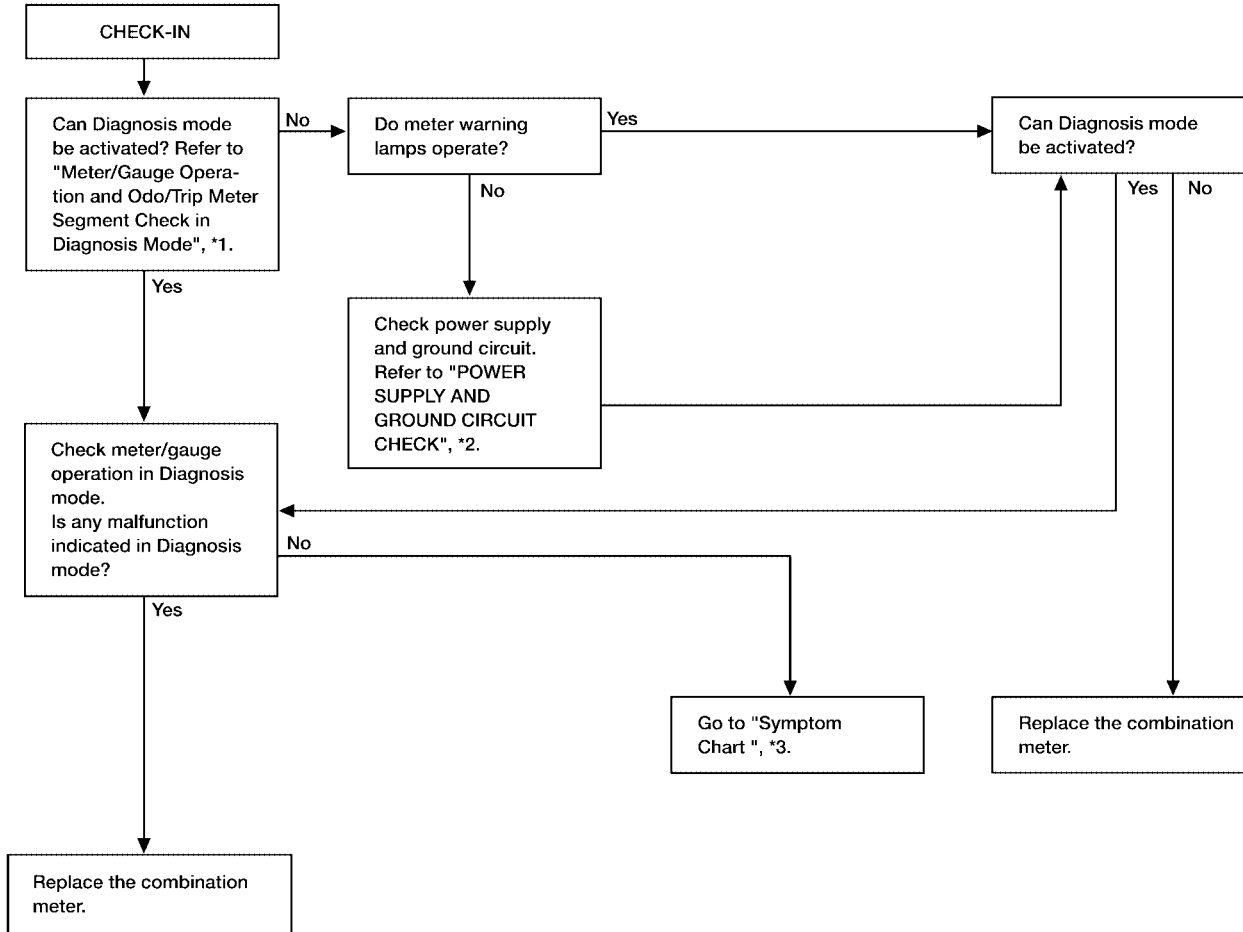

\*1: [DI-16](#)

\*2: [DI-18](#)

\*3: [DI-18](#)

WKIA0159E

A  
B  
C  
D  
E  
F  
G  
H  
I  
J  
DI  
L  
M

# METERS AND GAUGES

## SYMPTOM CHART

Symptom	Possible causes	Repair order
One meter/gauge (speedometer/tachometer/fuel gauge/water temp. gauge) is malfunctioning.	1. Sensor signal - Vehicle speed signal - Engine revolution signal - Fuel gauge - Water temp. gauge	1. Check the sensor for malfunctioning meter/gauge. <a href="#">DI-21. "INSPECTION/VEHICLE SPEED SENSOR"</a> <a href="#">DI-22. "INSPECTION/ENGINE REVOLUTION SIGNAL"</a> <a href="#">DI-23. "INSPECTION/FUEL LEVEL SENSOR UNIT AND FUEL PUMP"</a> <a href="#">DI-25. "INSPECTION/WATER TEMPERATURE GAUGE"</a>
Multiple meters/gauges (except odo/trip meter) are malfunctioning.	2. Unified meter control unit	2. Replace combination meter assembly.

Before starting trouble diagnoses below, perform "PRELIMINARY CHECK", [DI-17. "PRELIMINARY CHECK"](#) .

## POWER SUPPLY AND GROUND CIRCUIT CHECK

### 1. CHECK FUSE

Check for blown combination meter fuses.

Unit	Power source	Fuse No.
Combination meter	Battery	12
	Ignition switch ON or START	30

#### OK or NG

OK >> GO TO 2.

NG >> If fuse is blown, be sure to eliminate cause of malfunction before installing new fuse. Refer to [PG-3. "POWER SUPPLY ROUTING"](#) .

# METERS AND GAUGES

## 2. CHECK POWER SUPPLY CIRCUIT

1. Disconnect combination meter connector M29 (QR25DE) or M29 and M30 for (QG18DE).
2. Check voltage between combination meter harness connector terminals and ground.

### (QG18DE WITHOUT TACHOMETER)

Terminals		Ignition switch position			
(+)		(-)	OFF	ACC	ON
Connector	Terminal (Wire color)				
M30	25 (R/B)	Ground	Battery voltage	Battery voltage	Battery voltage
	26 (Y)		0V	0V	Battery voltage
M29	20 (Y)		0V	0V	Battery voltage

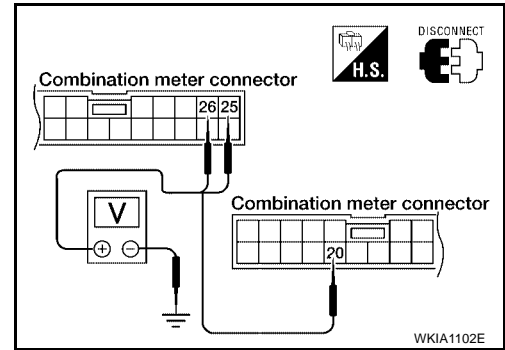

### (QG18DE WITH TACHOMETER)

Terminals		Ignition switch position			
(+)		(-)	OFF	ACC	ON
Connector	Terminal (Wire color)				
M30	42 (R/B)	Ground	Battery voltage	Battery voltage	Battery voltage
	41 (Y)		0V	0V	Battery voltage
M29	6 (Y)		0V	0V	Battery voltage

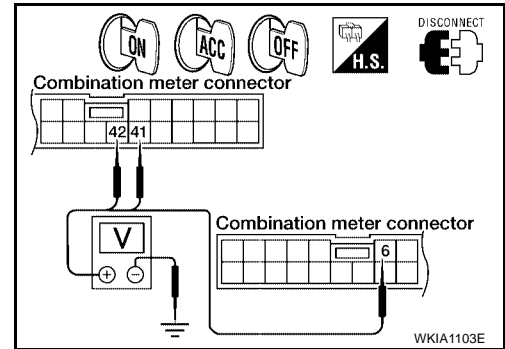

### (QR25DE)

Terminals		Ignition switch position			
(+)		(-)	OFF	ACC	ON
Connector	Terminal (Wire color)				
M29	13 (R/B)	Ground	Battery voltage	Battery voltage	Battery voltage
	14 (Y)		0V	0V	Battery voltage
	7 (Y)		0V	0V	Battery voltage

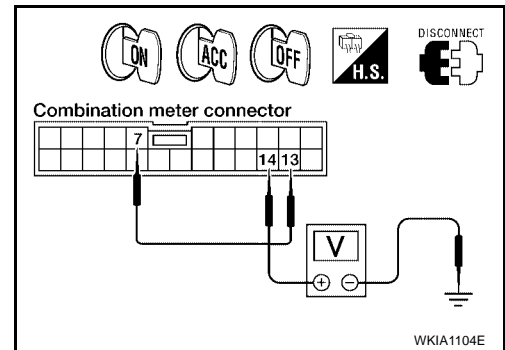

### OK or NG

OK >> GO TO 3.

NG >> Check the following.

- Harness for open between combination meter and fuse

# METERS AND GAUGES

## 3. CHECK GROUND CIRCUIT

Check continuity between combination meter harness connector terminals and ground.

### (QG18DE WITHOUT TACHOMETER)

Terminals			Continuity
(+)		(-)	
Connector	Terminal (Wire color)		
M30	27 (B)	Ground	Yes

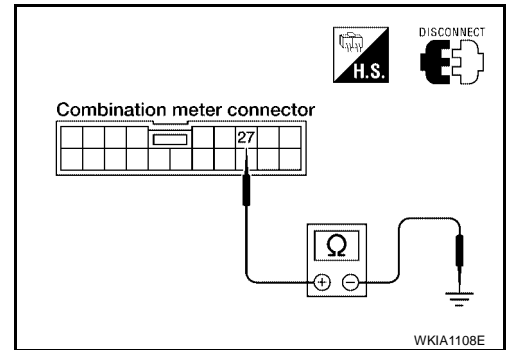

### (QG18DE WITH TACHOMETER)

Terminals			Continuity
(+)		(-)	
Connector	Terminal (Wire color)		
M30	48 (B)	Ground	Yes

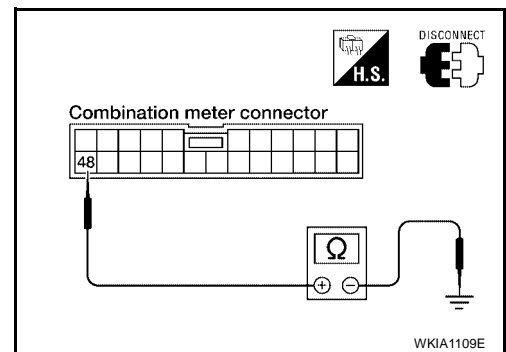

### (QR25DE)

Terminals			Continuity
(+)		(-)	
Connector	Terminal (Wire color)		
M29	12 (B)	Ground	Yes

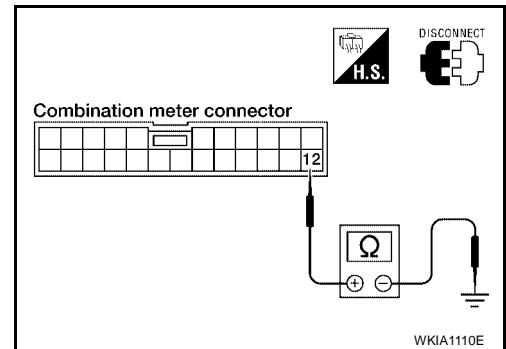

#### OK or NG

- OK >> Inspection End.
- NG >> Repair harness or connector.

# METERS AND GAUGES

## INSPECTION/VEHICLE SPEED SENSOR

### 1. CHECK VEHICLE SPEED SENSOR OUTPUT

1. Remove vehicle speed sensor from transmission.
2. Check voltage between the combination meter terminal and ground while quickly turning speed sensor pinion.

Terminals			Voltage
(+)		(-)	
Connector	Terminal (Wire color)		
QG18DE (WITHOUT TACHOMETER)			
M30	29 (R/Y)	Ground	Approx. 0.5V
QG18DE (WITH TACHOMETER)			
M30	47 (R/Y)	Ground	Approx. 0.5V
QR25DE			
M29	17 (R/Y)	Ground	Approx. 0.5V

#### OK or NG

- OK >> Vehicle speed sensor is OK.  
 NG >> GO TO 2.

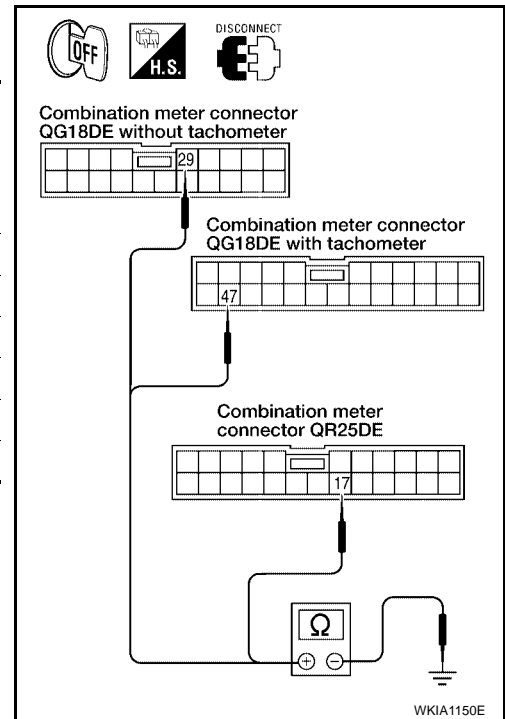

### 2. CHECK VEHICLE SPEED SENSOR

Check resistance between vehicle speed sensor connector F43 terminals 1 and 2 (with QG18DE), or connector F36 terminals + and - (with QR25DE).

**Resistance**      **Approx. 250Ω**

#### OK or NG

- OK >> Check the following.
- Harness between combination meter and vehicle speed sensor.
  - Vehicle speed sensor ground circuit.
- NG >> Replace vehicle speed sensor.

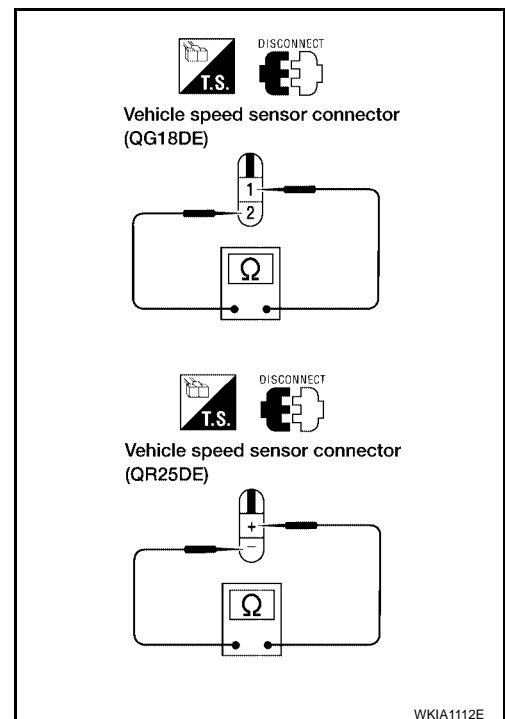

# METERS AND GAUGES

---

## INSPECTION/ENGINE REVOLUTION SIGNAL

### 1. CHECK ECM SELF-DIAGNOSIS

---

Perform ECM self diagnosis. Refer to [EC-138, "SELF-DIAG RESULTS MODE"](#) (QG18DE models) or [EC-796, "SELF-DIAG RESULTS MODE"](#) (QR25DE models).

OK or NG

OK >> Replace combination meter.

NG >> Go to ECM trouble diagnosis. Refer to [EC-97, "TROUBLE DIAGNOSIS"](#) (QG18DE models) or [EC-756, "TROUBLE DIAGNOSIS"](#) (QR25DE models).

# METERS AND GAUGES

## INSPECTION/FUEL LEVEL SENSOR UNIT AND FUEL PUMP

### 1. CHECK GROUND CIRCUIT FOR FUEL LEVEL SENSOR UNIT

Check harness continuity between fuel level sensor unit and fuel pump connector terminal 5 and ground.

**Continuity should exist.**

OK or NG

OK >> GO TO 2.

NG >> Repair harness or connector.

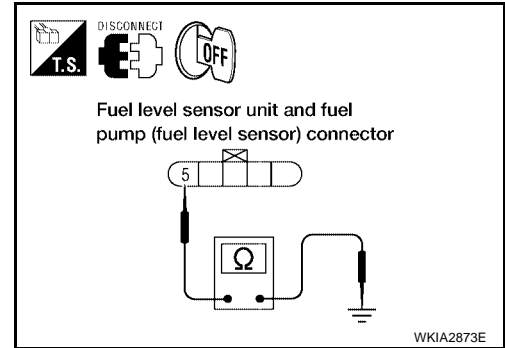

### 2. CHECK FUEL LEVEL SENSOR UNIT

Refer to [DI-26, "FUEL LEVEL SENSOR UNIT CHECK"](#) .

OK or NG

OK >> GO TO 3.

NG >> Replace fuel level sensor unit. Refer to [FL-3, "Removal and Installation"](#) .

A  
B  
C  
D  
E  
F  
G  
H  
I  
J  
DI  
L  
M

# METERS AND GAUGES

## 3. CHECK HARNESS FOR OPEN OR SHORT

1. Disconnect combination meter connector and fuel level sensor unit and fuel pump connector.
2. Check continuity between combination meter terminal and fuel level sensor unit and fuel pump connector terminal.

Terminals				Continuity
(+)		(-)		
Connector	Terminal (Wire color)	Connector	Terminal (Wire color)	
QG18DE (WITHOUT TACHOMETER)				
M30	30 (G)	B25	2 (G)	Yes
QG18DE (WITH TACHOMETER)				
M30	44 (G)	B25	2 (G)	Yes
QR25DE				
M29	21 (G)	B25	2 (G)	Yes

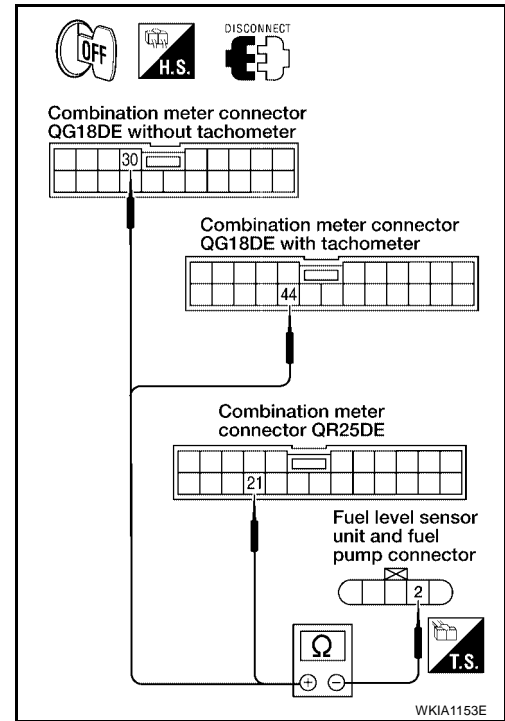

3. Check continuity between combination meter terminal and ground.

Terminals			Continuity
(+)		(-)	
Connector	Terminal (Wire color)		
QG18DE (WITHOUT TACHOMETER)			
M30	30 (G)	Ground	No
QG18DE (WITH TACHOMETER)			
M30	44 (G)	Ground	No
QR25DE			
M29	21 (G)	Ground	No

### OK or NG

- OK >> Fuel level sensor unit is OK.  
 NG >> Repair harness or connector.

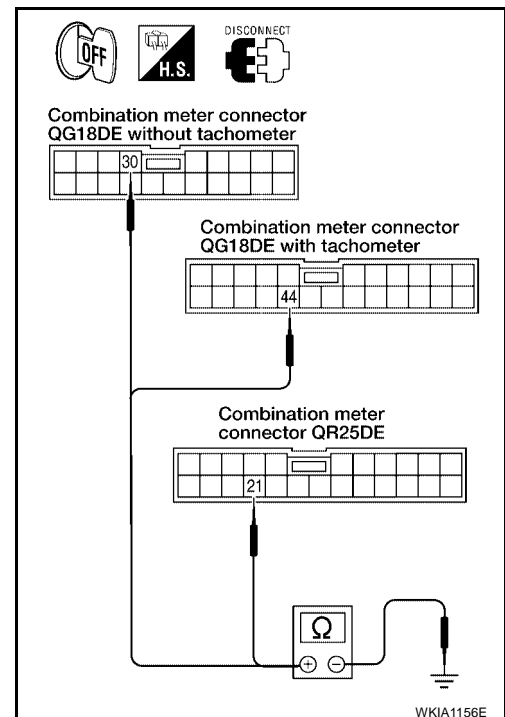



# METERS AND GAUGES

---

## INSPECTION/WATER TEMPERATURE GAUGE

### 1. CHECK ECM SELF-DIAGNOSIS

---

Perform ECM self diagnosis. Refer to [EC-138, "SELF-DIAG RESULTS MODE"](#) (QG18DE models) or [EC-796, "SELF-DIAG RESULTS MODE"](#) (QR25DE models).

OK or NG

OK >> Replace combination meter.

NG >> Go to ECM trouble diagnosis. Refer to [EC-97, "TROUBLE DIAGNOSIS"](#) (QG18DE models) or [EC-756, "TROUBLE DIAGNOSIS"](#) (QR25DE models).

A  
B  
C  
D  
E  
F  
G  
H  
I  
J  
DI  
L  
M

DI

# METERS AND GAUGES

## Electrical Components Inspection FUEL LEVEL SENSOR UNIT CHECK

EKS0039G

- For removal, refer to [FL-3, "Removal and Installation"](#) .  
Check the resistance between terminals 2 and 5.

Ohmmeter		Float position		mm (in)	Resistance (Approximate)
(+)	(-)				
2	5	*1	Full	136.1 (5.358)	4.5 - 5.5 Ω
		*2	1/2	89.8 (3.535)	31.5 - 33.5 Ω
		*3	Empty	31.3 (1.232)	80 - 83 Ω

\*1 and \*3: When float rod is in contact with stopper.

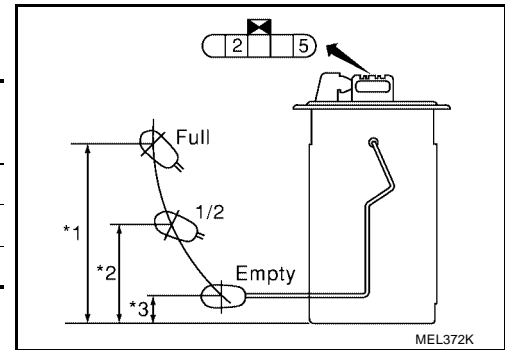

## VEHICLE SPEED SENSOR SIGNAL CHECK

- Remove vehicle speed sensor from transmission.
- Turn vehicle speed sensor pinion quickly and measure voltage across terminals 1 and 2 (with QG18DE), or terminals + and - (with QR25DE).

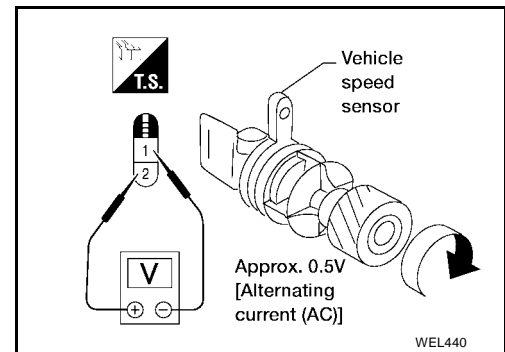

## Removal and Installation of Combination Meter

EKS008XR

For removal and installation procedure, refer to [IP-10, "Removal and Installation"](#) .

# WARNING LAMPS

## WARNING LAMPS

### Schematic WITHOUT TACHOMETER

PF:24814

EKS0039H

- U : USA
- N : CANADA
- A : WITH A/T

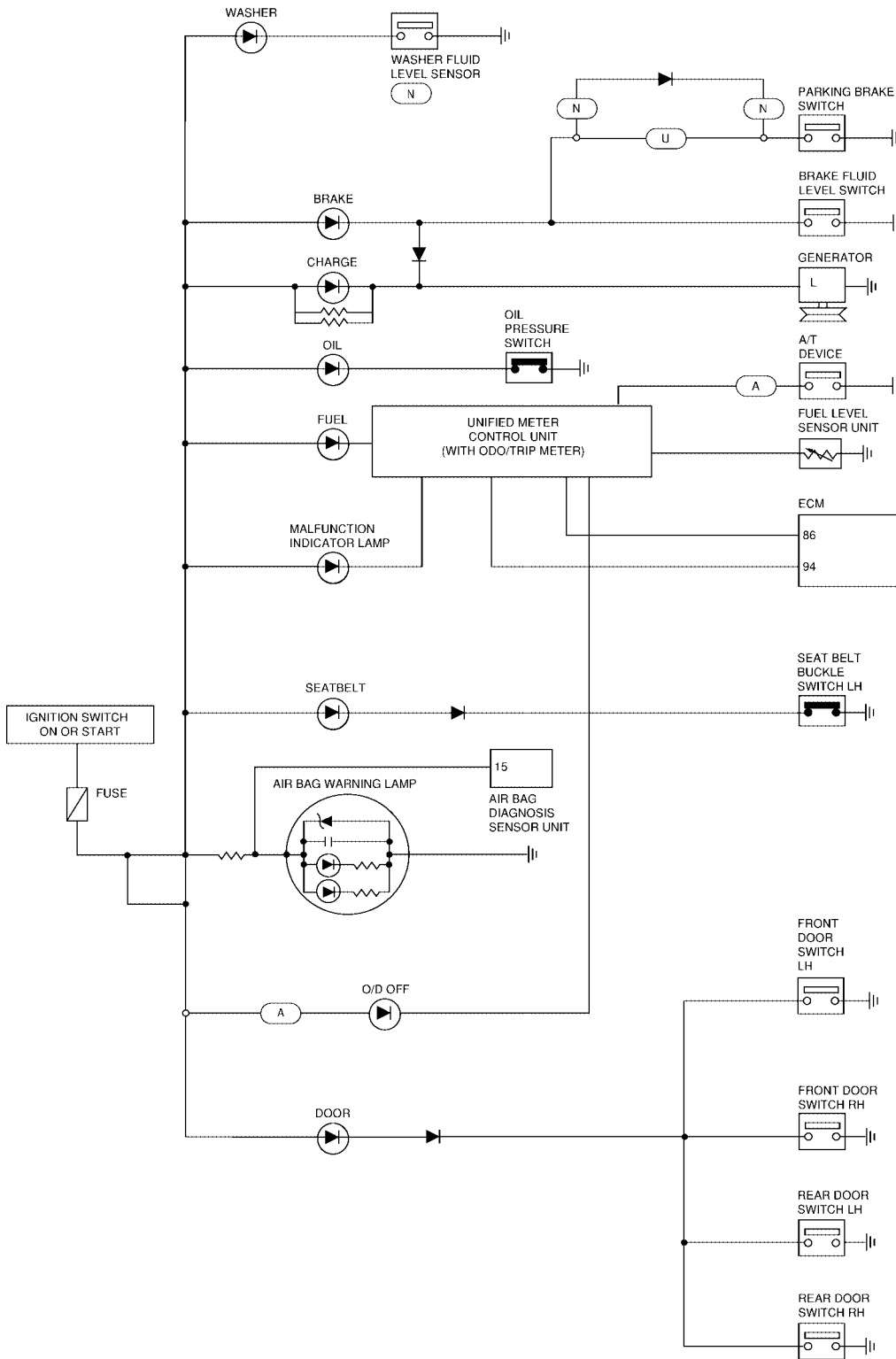

A  
B  
C  
D  
E  
F  
G  
H  
I  
J  
DI  
L  
M

# WARNING LAMPS

## WITH TACHOMETER

- U : USA
- N : CANADA
- AB : WITH ABS
- A : WITH A/T

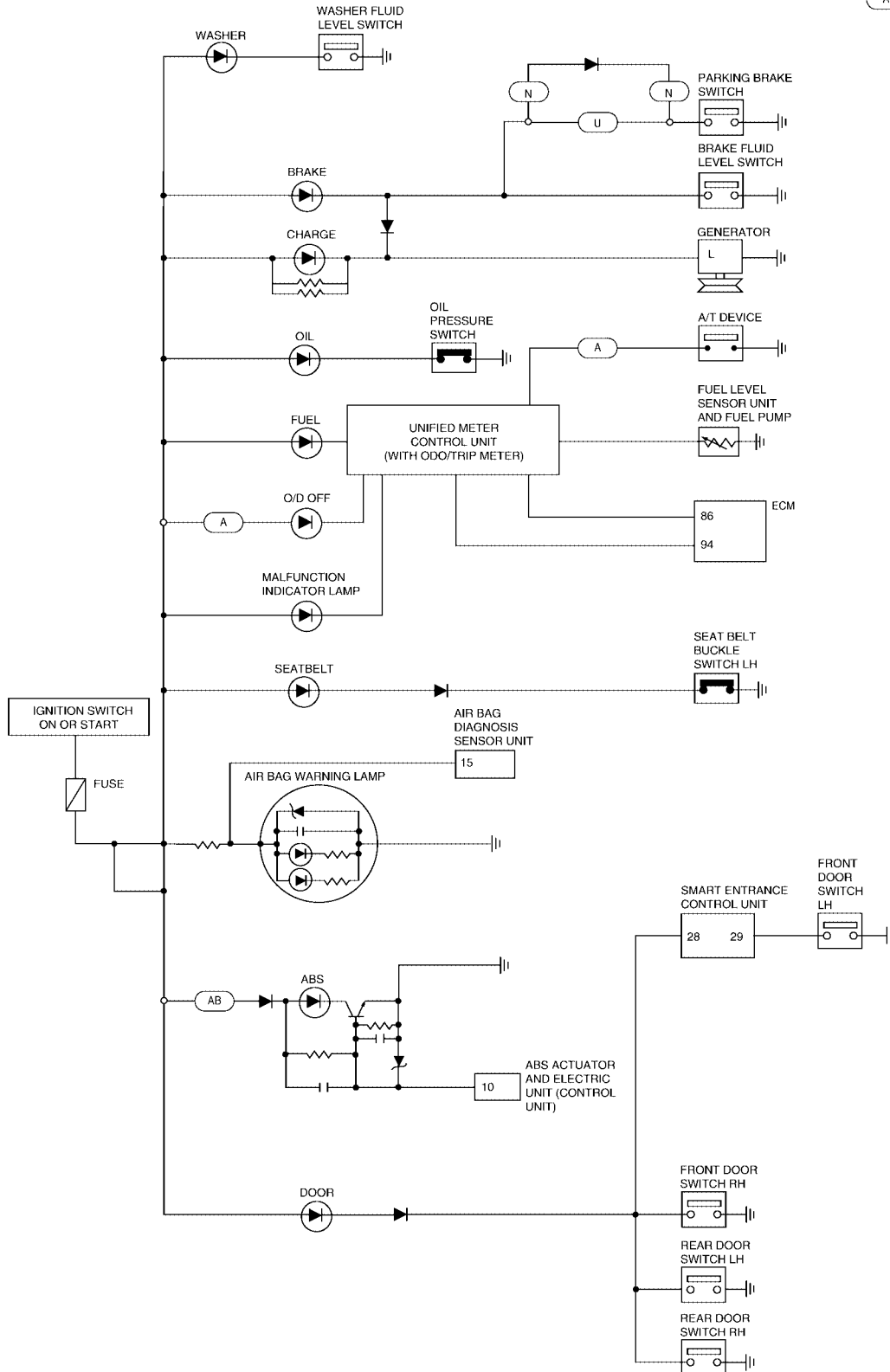

WKWA0610E

# WARNING LAMPS

EKS0039I

## Wiring Diagram — WARN — WITHOUT TACHOMETER

DI-WARN-01

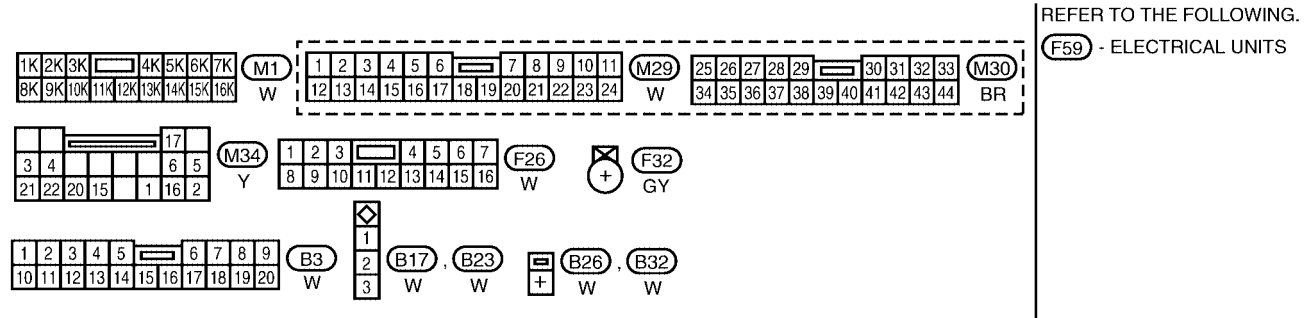
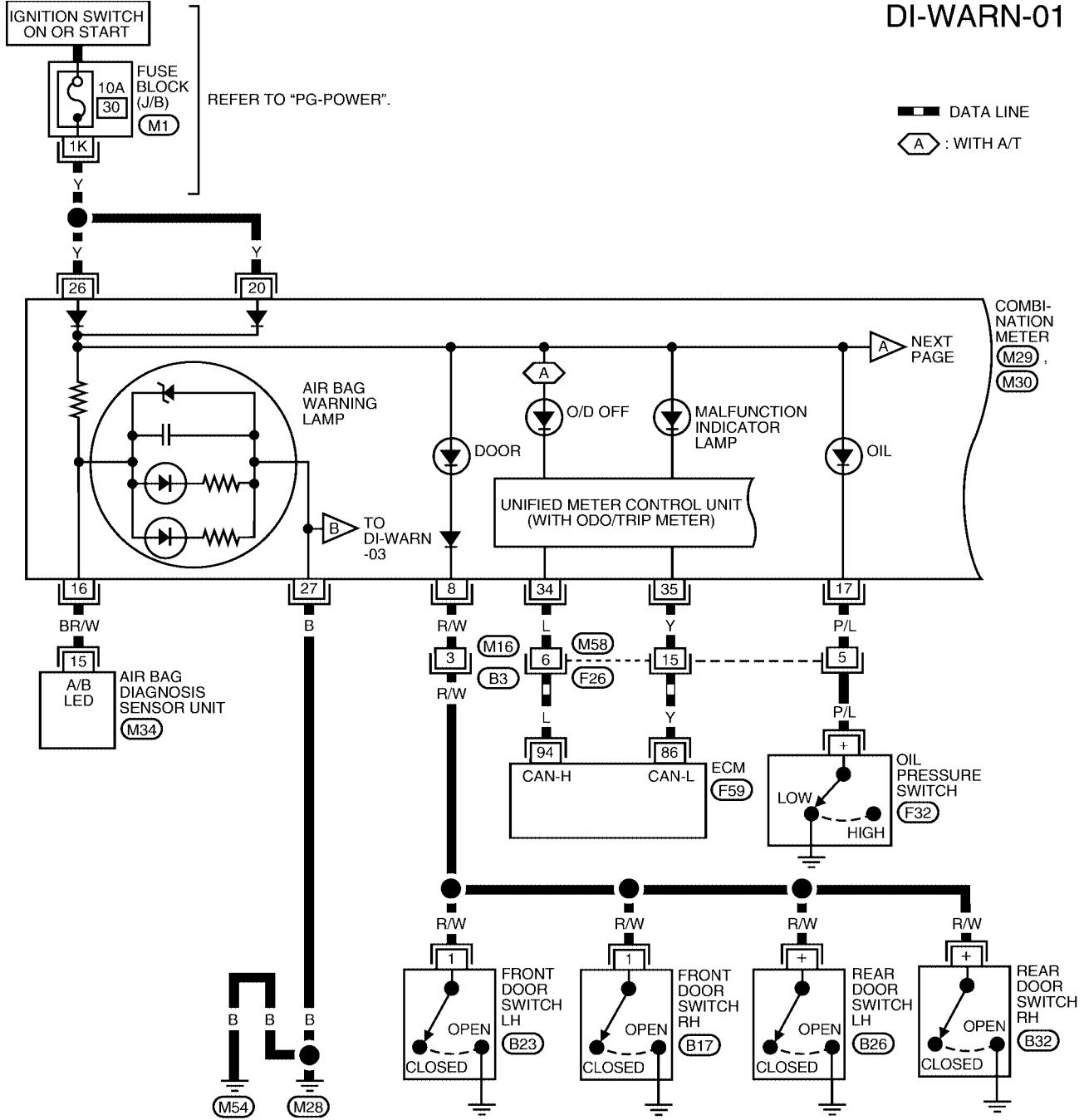

# WARNING LAMPS

DI-WARN-02

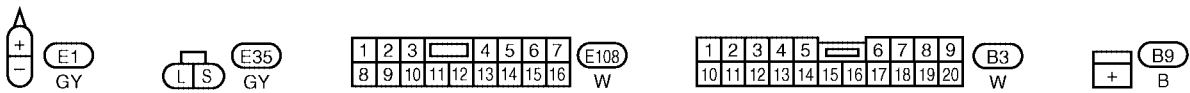
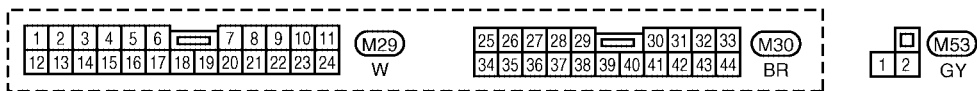
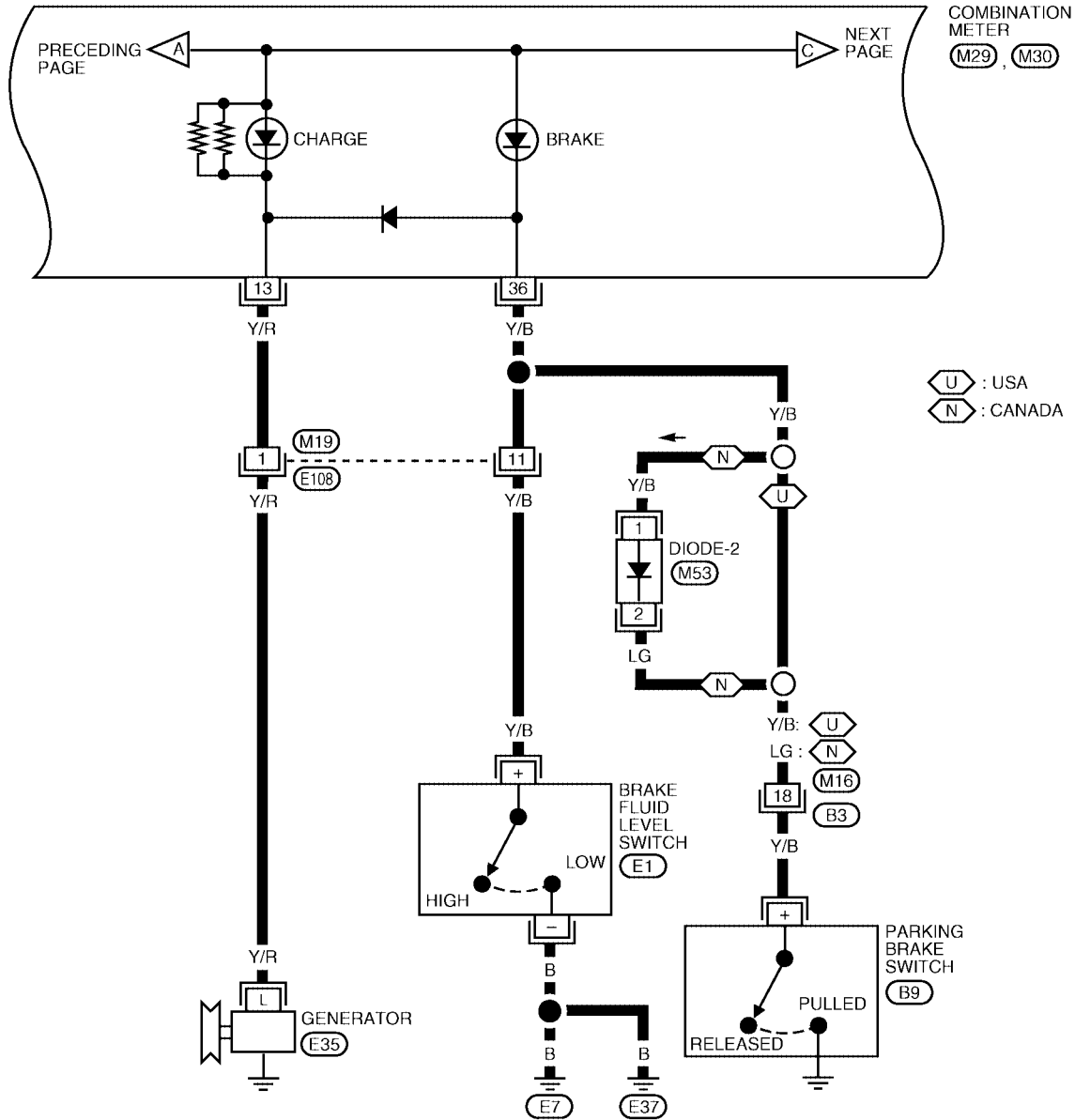

WKWA1616E

# WARNING LAMPS

DI-WARN-03

(N) : CANADA  
(A) : WITH A/T

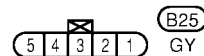
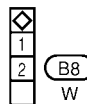
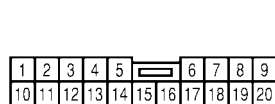
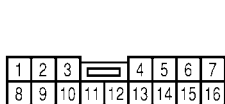
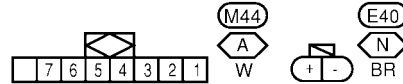
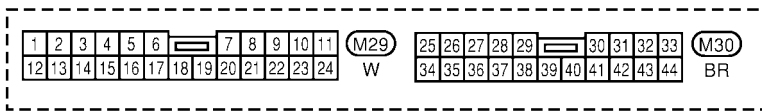
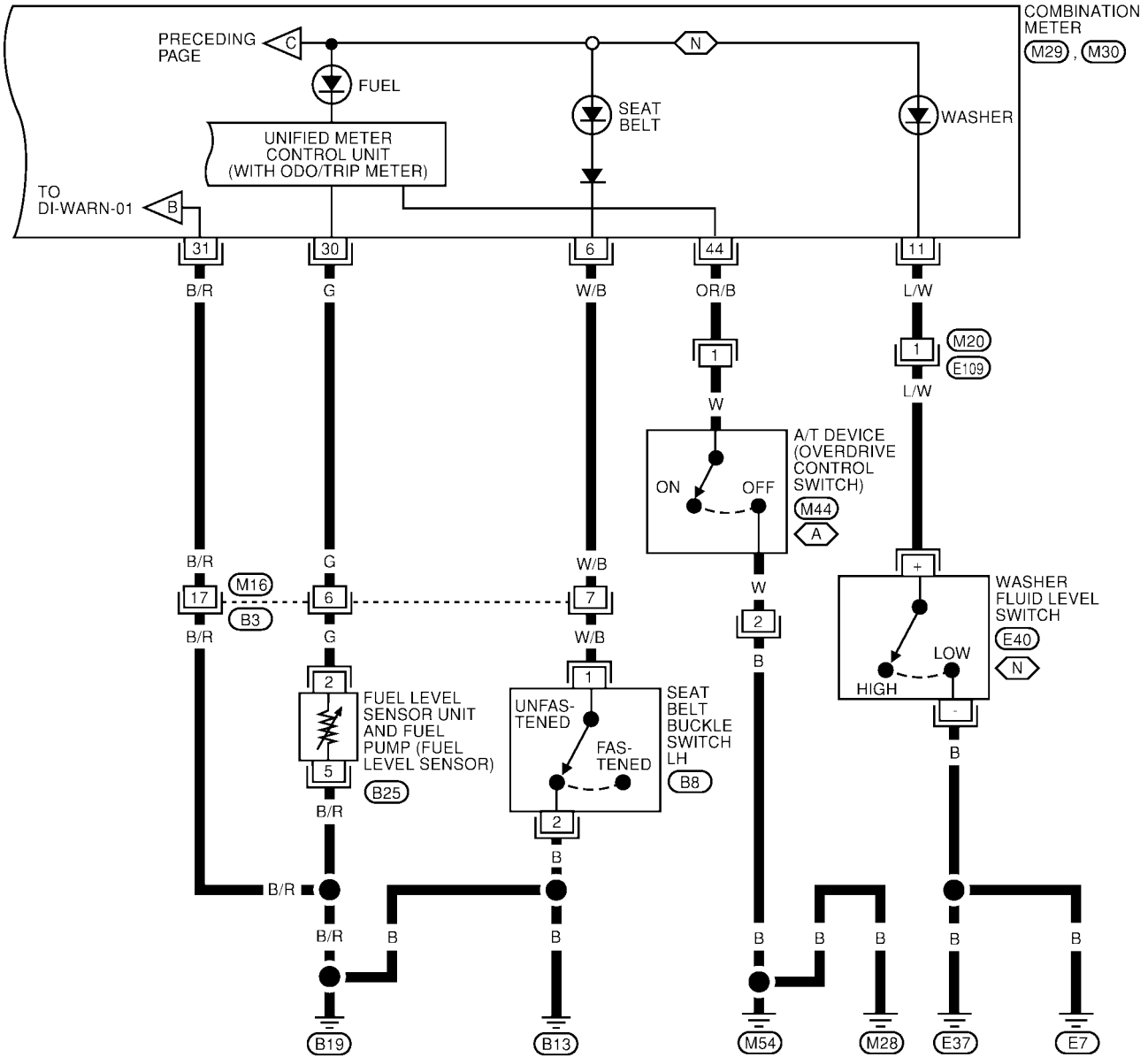

WKWA1617E

# WARNING LAMPS

## WITH TACHOMETER (QG18DE MODELS)

DI-WARN-04

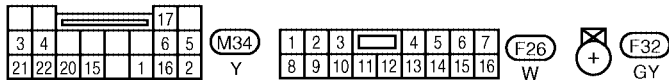
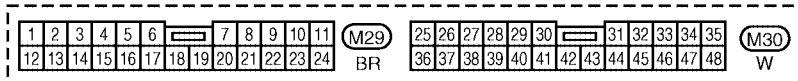
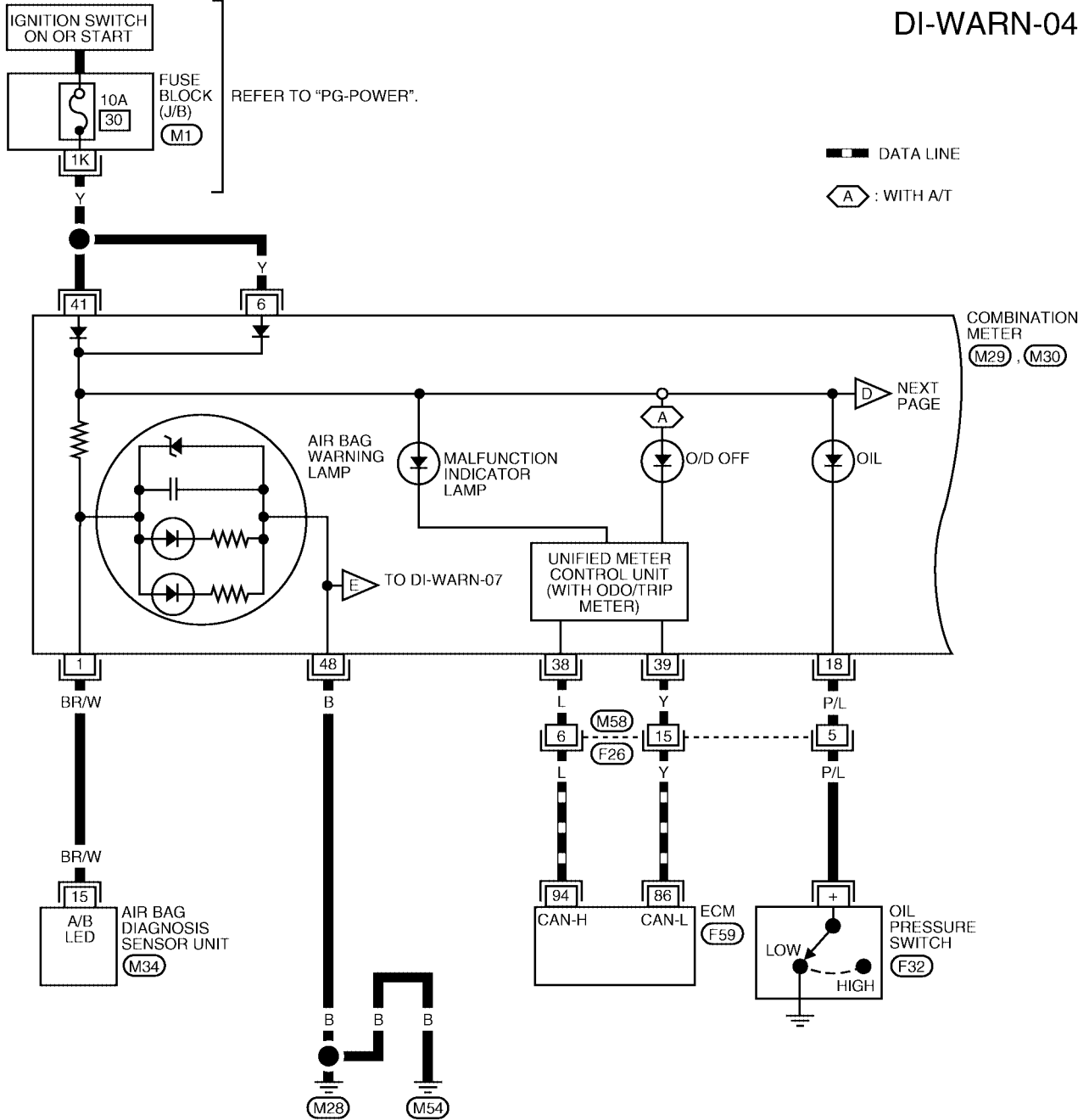

REFER TO THE FOLLOWING.  
(F59) - ELECTRICAL UNITS

WKWA1618E



# WARNING LAMPS

DI-WARN-05

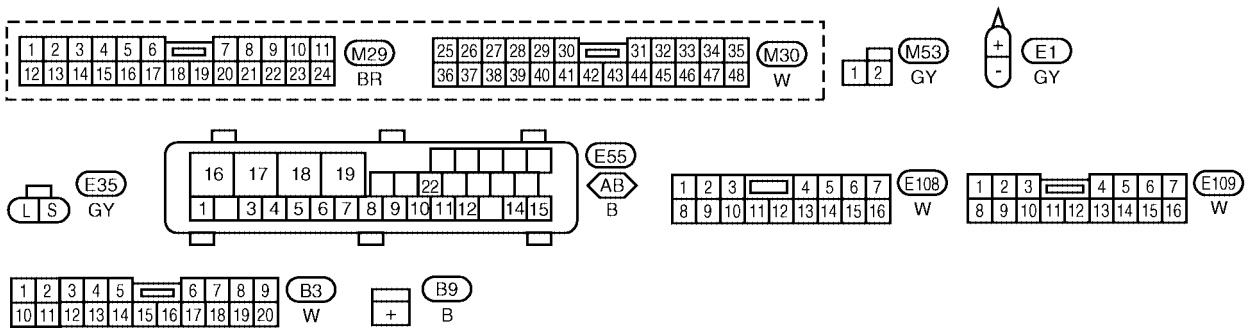
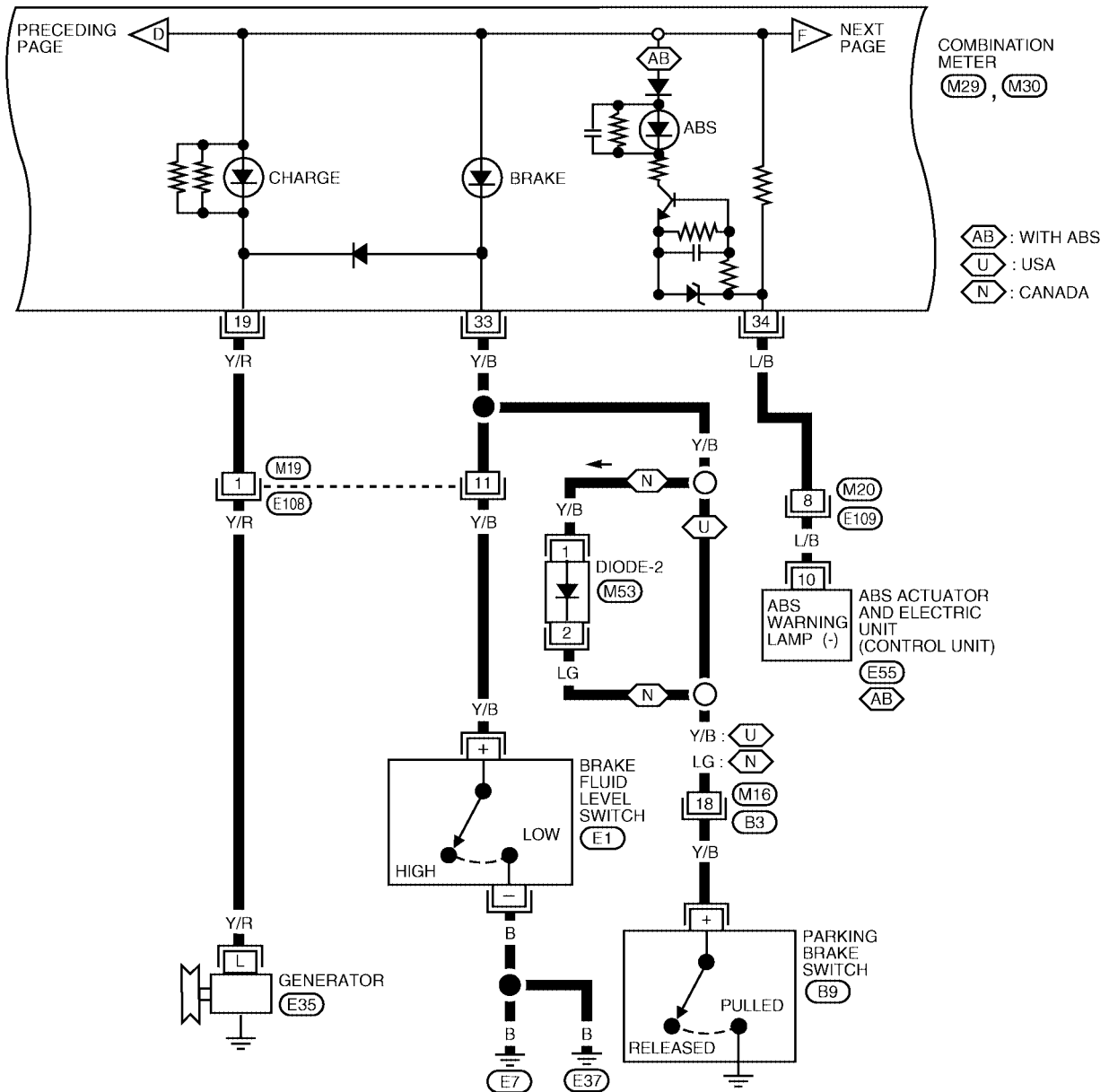

WKWA1619E

# WARNING LAMPS

DI-WARN-06

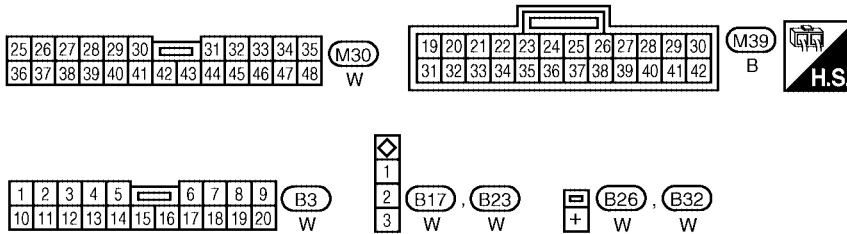
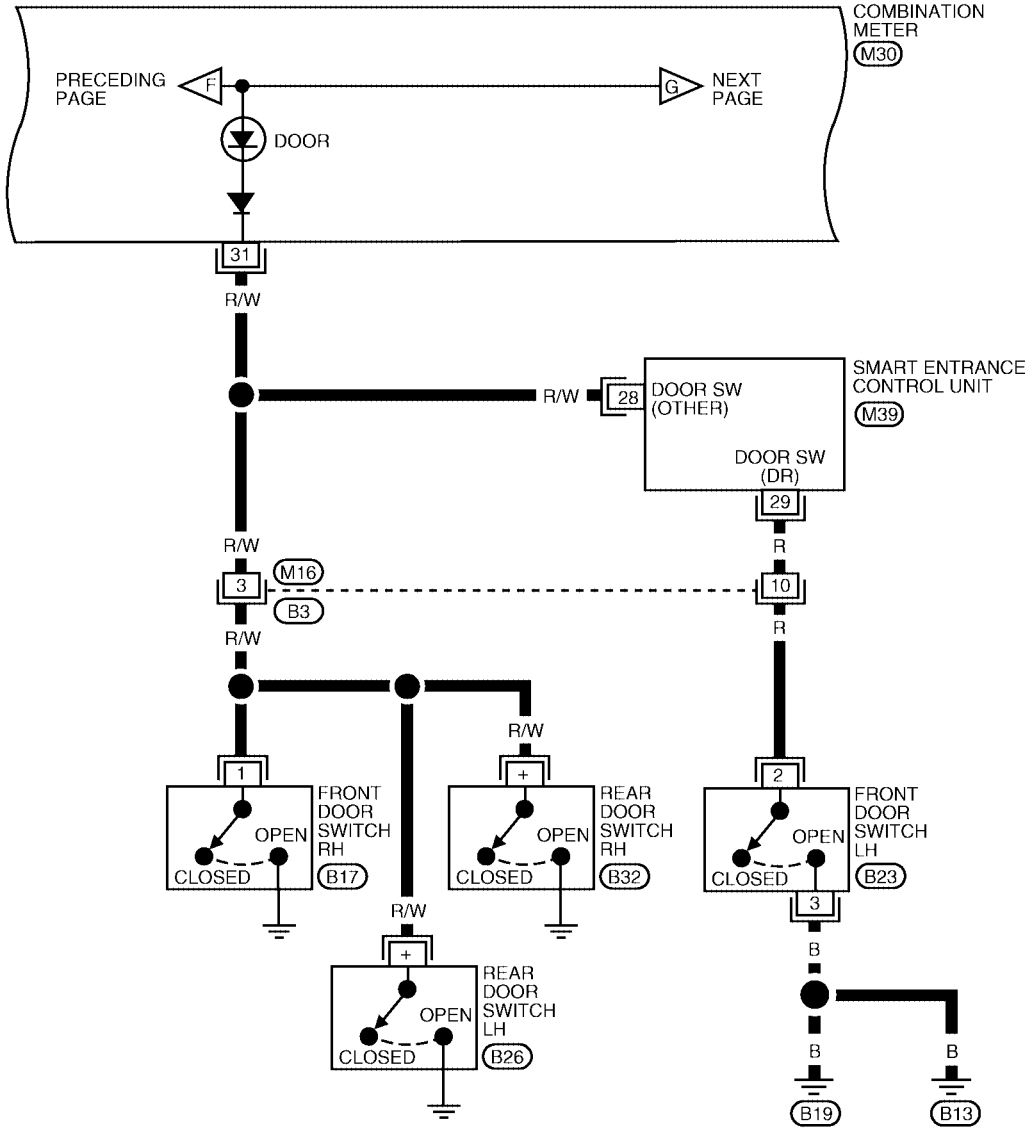

WKWA1620E

# WARNING LAMPS

DI-WARN-07

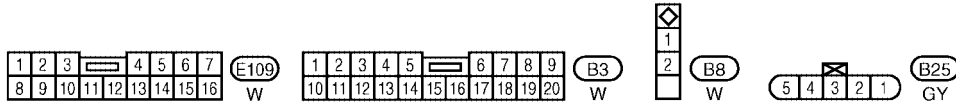
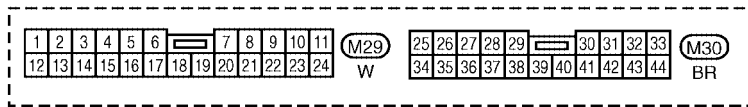
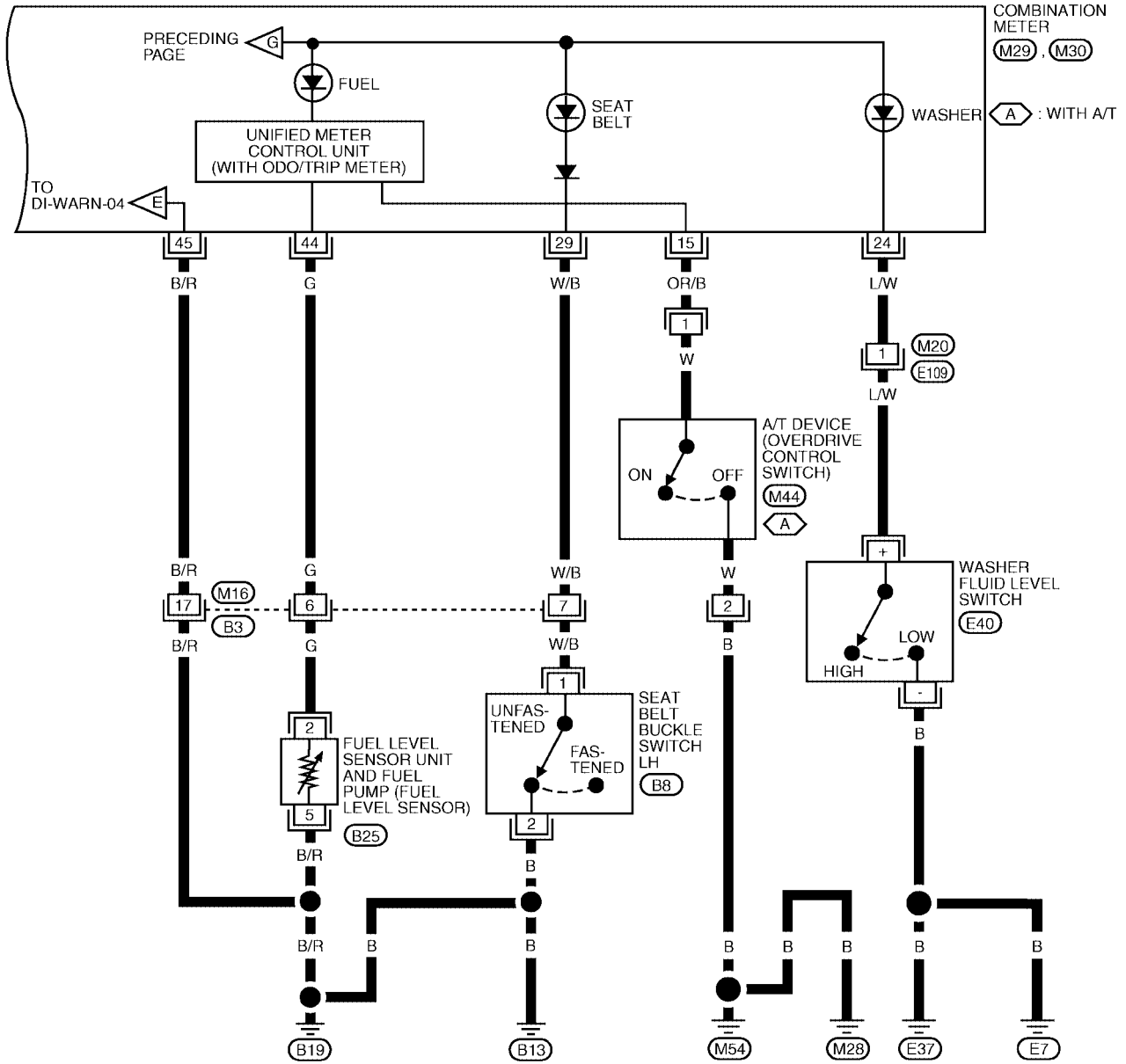

A  
B  
C  
D  
E  
F  
G  
H  
I  
J  
K  
L  
M

DI

# WARNING LAMPS

## WITH TACHOMETER (QR25DE MODELS)

DI-WARN-08

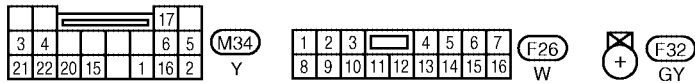
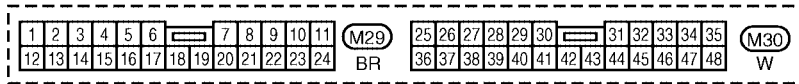
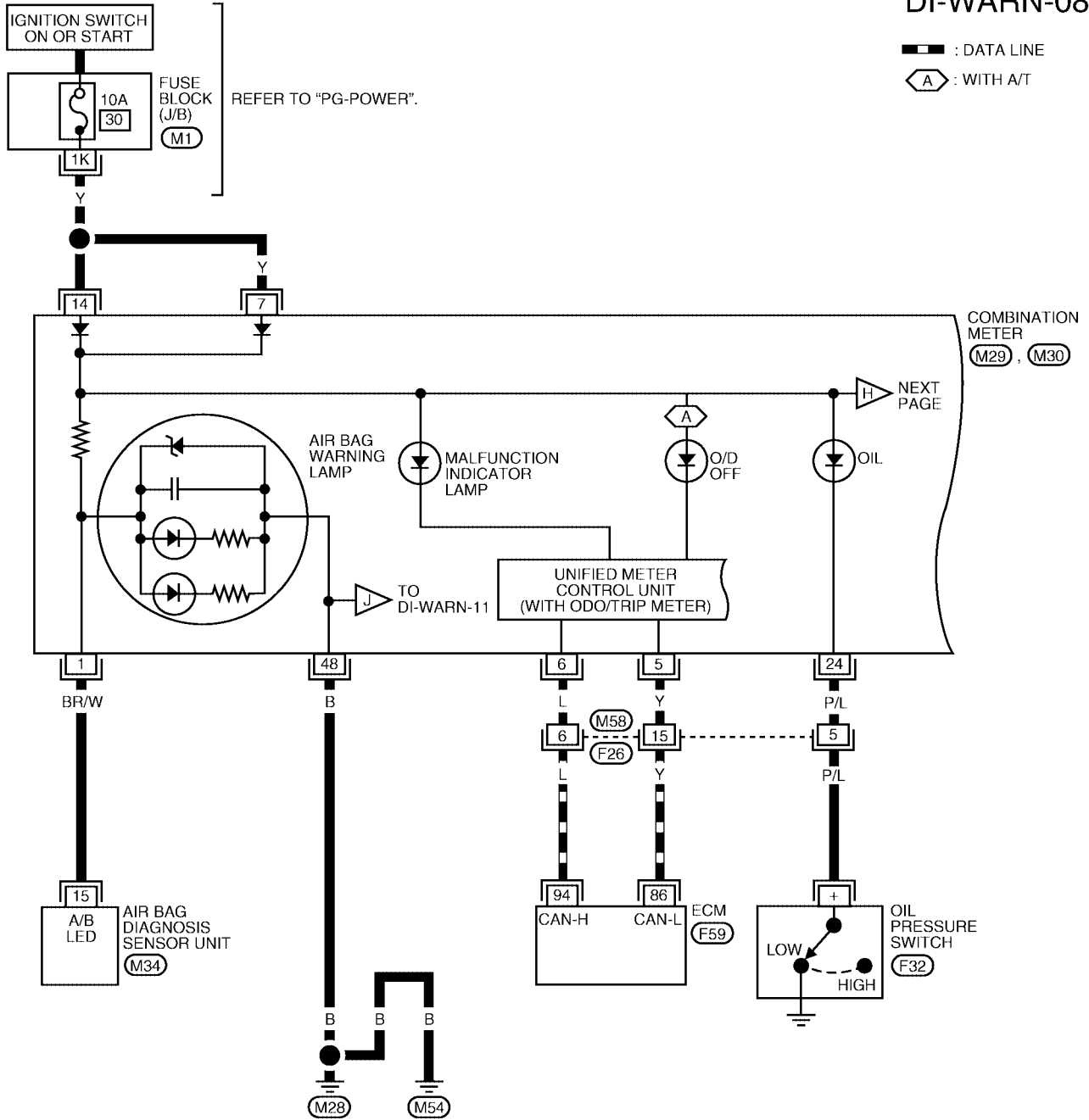

REFER TO THE FOLLOWING.  
 (F59) - ELECTRICAL UNITS

WKWA1622E

# WARNING LAMPS

DI-WARN-09

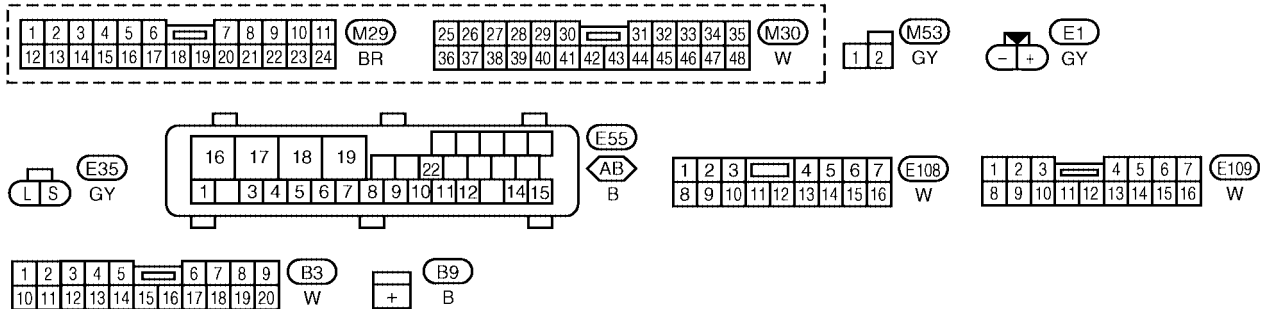
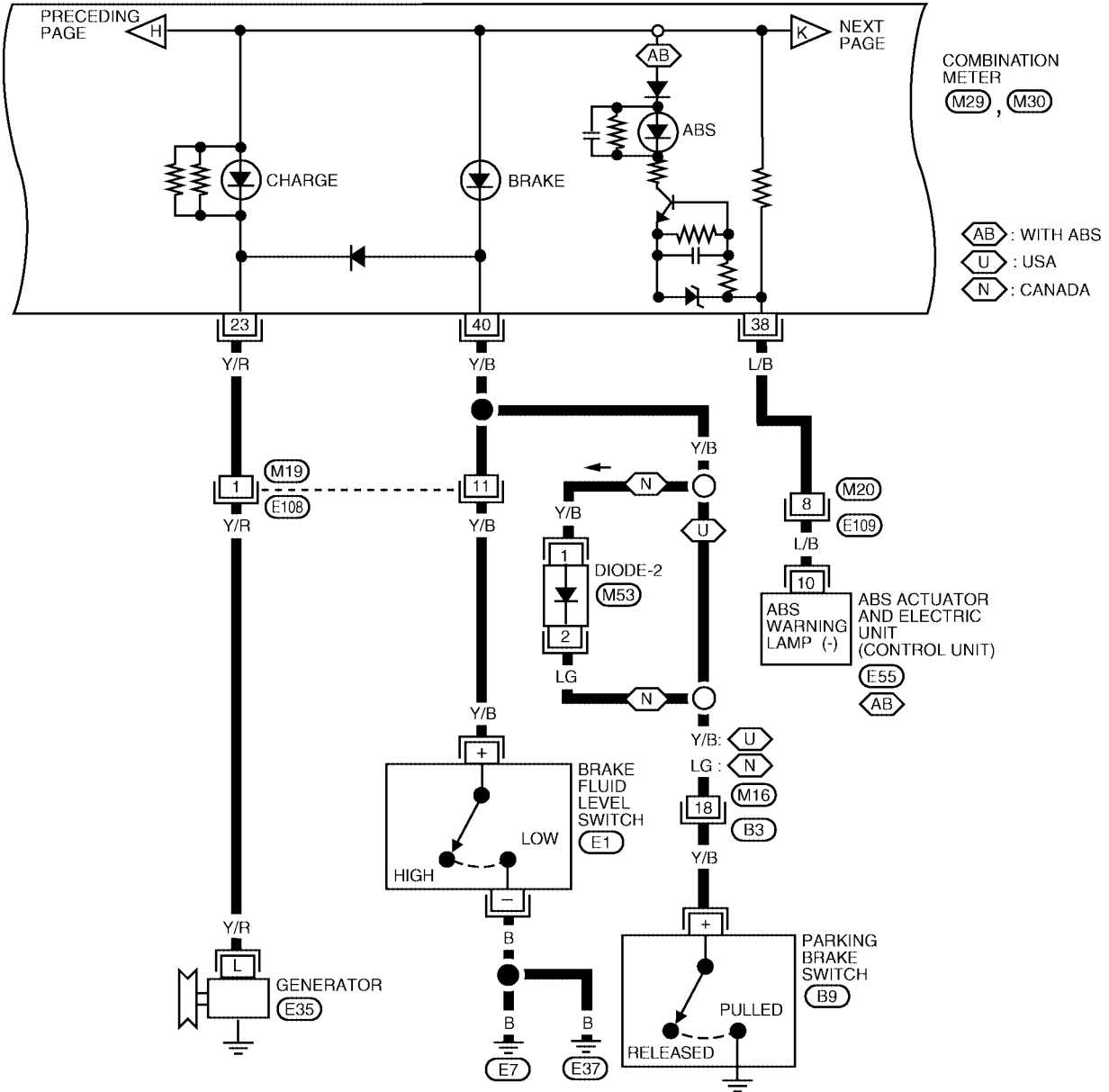

WKWA1623E

# WARNING LAMPS

DI-WARN-10

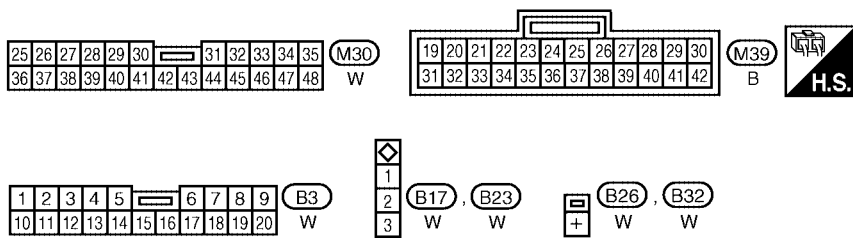
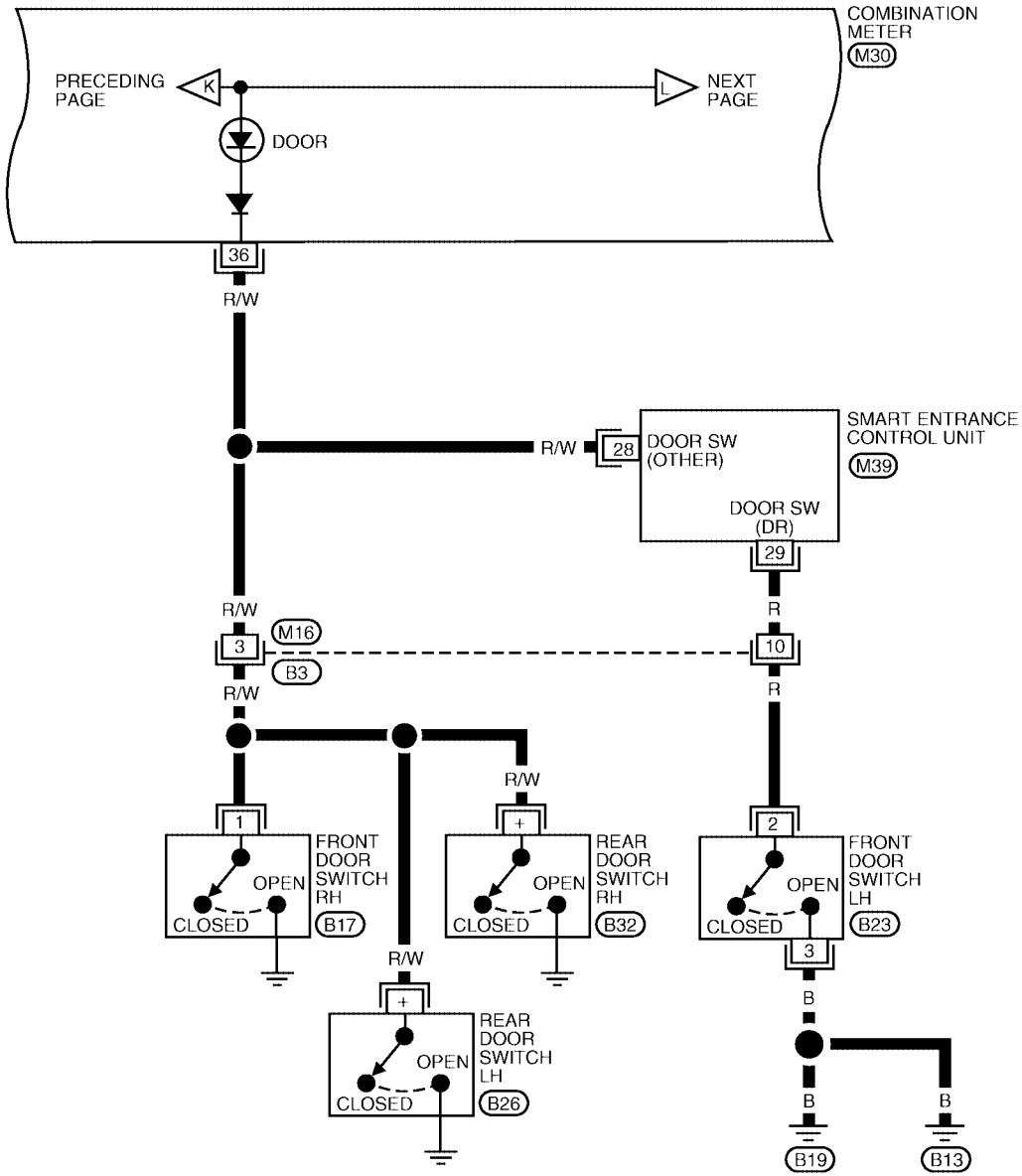

WKWA1624E

# WARNING LAMPS

DI-WARN-11

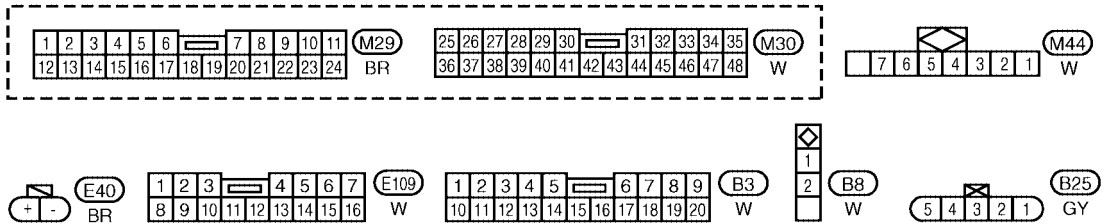
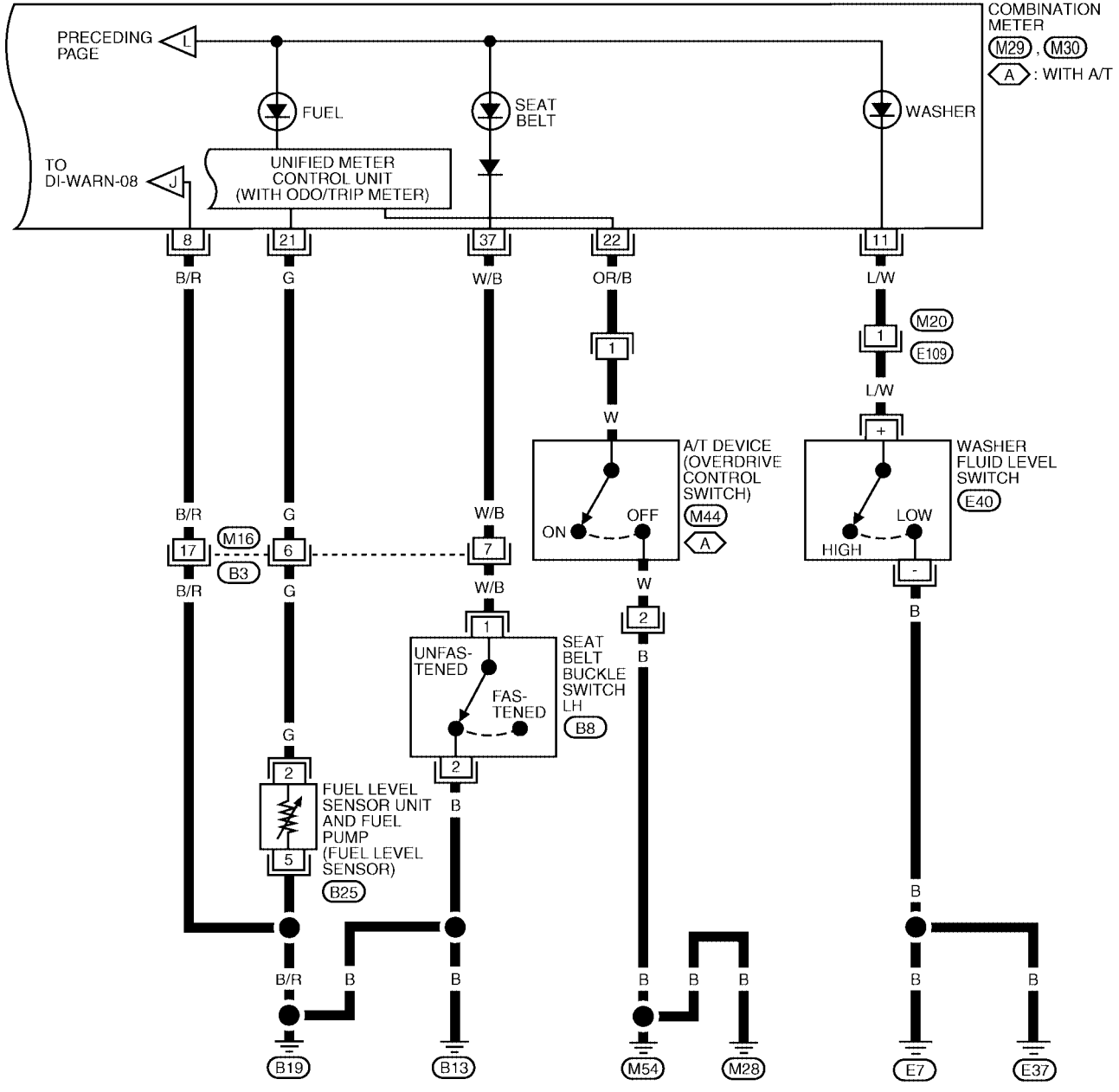

WKWA1625E

# WARNING LAMPS

EKS0039J

## Electrical Components Inspection FUEL WARNING LAMP OPERATION CHECK

1. Turn ignition switch OFF.
2. Disconnect fuel level sensor unit and fuel pump harness connector B25.
3. Connect a resistor (80Ω) between fuel level sensor unit and fuel pump harness connector terminals 2 and 5.
4. Turn ignition switch ON.

The fuel warning lamp should come on.

### NOTE:

ECM might store the 1st trip DTC P0180 and the 1st trip DTC P0464 during this inspection.

If the DTC is stored in ECM memory, erase the DTC after reconnecting fuel level sensor unit and fuel pump harness connector.

Refer to [EC-64, "HOW TO ERASE EMISSION-RELATED DIAGNOSTIC INFORMATION"](#) (QG18DE), [EC-712, "HOW TO ERASE EMISSION-RELATED DIAGNOSTIC INFORMATION"](#) (QR25DE).

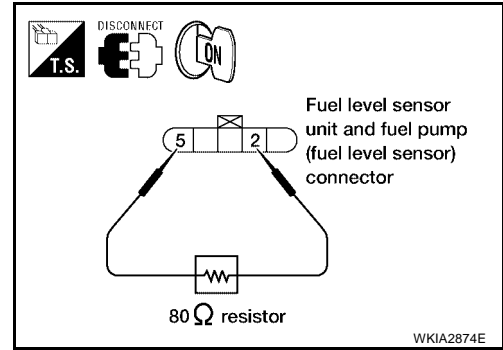

## OIL PRESSURE SWITCH CHECK

Check the continuity between the terminals of oil pressure switch and body ground.

Condition	Oil pressure kPa (kg/cm <sup>2</sup> , psi)	Continuity
Engine running	More than 10 - 20 (0.1 - 0.2, 1 - 3)	No
Engine not running	Less than 10 - 20 (0.1 - 0.2, 1 - 3)	Yes

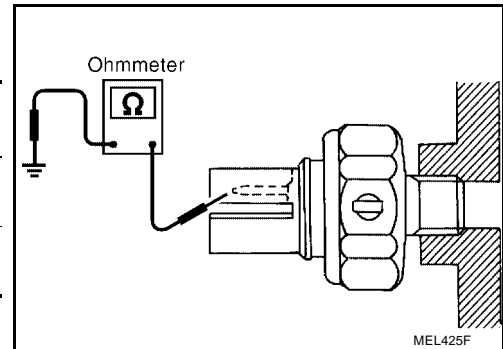

## DIODE CHECK

- Check continuity using an ohmmeter.
- Diode is functioning properly if test results are as shown in the figure.
- Check diodes at the combination meter harness connector instead of on the combination meter assembly. Refer to [DI-29, "Wiring Diagram — WARN —"](#).

### NOTE:

Specification may vary depending on the type of tester. Before performing this inspection, be sure to refer to the instruction manual for the tester to be used.

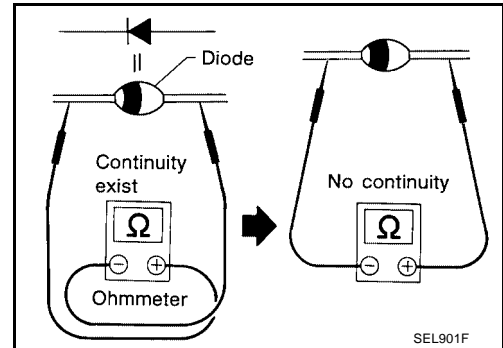



# WARNING CHIME

## WARNING CHIME

PF:24814

### Component Parts and Harness Connector Location

EKS0039K

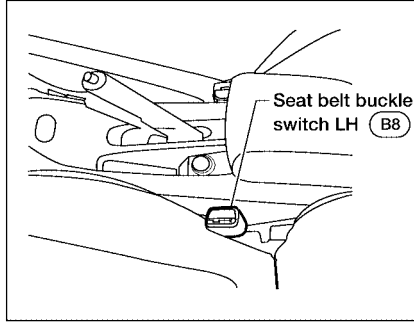
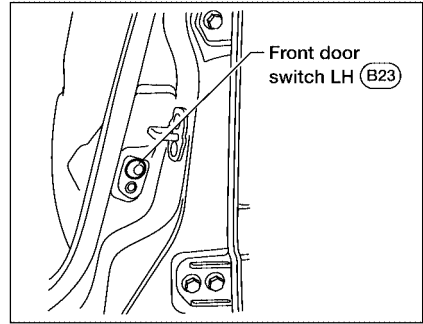
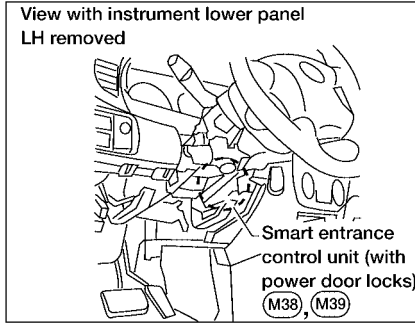
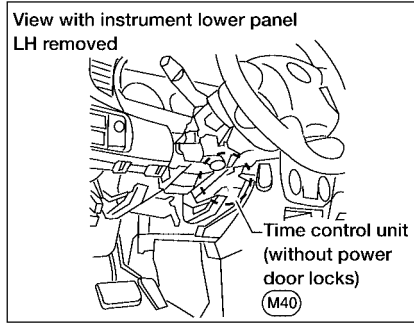
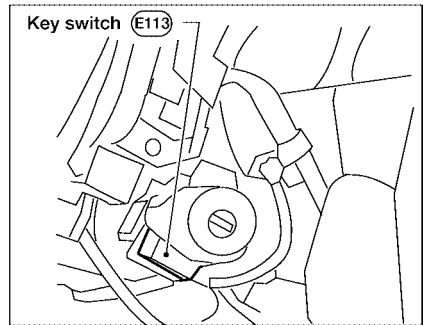
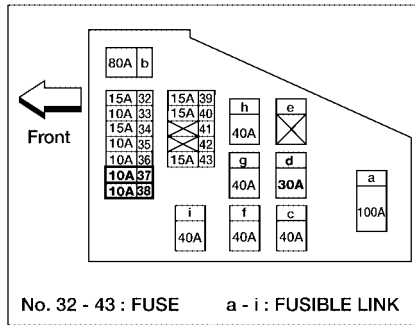
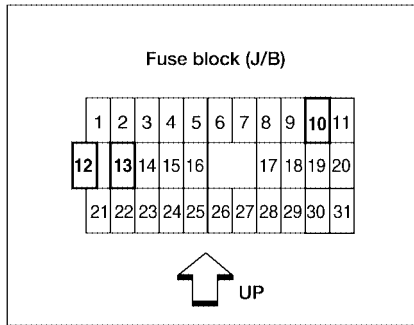

WKIA0160E

A  
B  
C  
D  
E  
F  
G  
H  
I  
J  
DI  
L  
M

# WARNING CHIME

EKS0039L

## System Description WITHOUT POWER DOOR LOCKS

The warning chime is controlled by the time control unit.

The warning chime is located in the time control unit.

Power is supplied at all times:

- through 10A fuse [No. 13, located in fuse block (J/B)]
- to time control unit terminal 7
- through 10A fuse [No. 12, located in the fuse block (J/B)]
- to key switch terminal 2, and
- through 10A fuse (No. 38, located in the fuse and fusible link box)
- to combination switch (lighting switch) terminal 11.

With the ignition switch in the ON or START position, power is supplied:

- through 10A fuse [No. 10, located in the fuse block (J/B)]
- to time control unit terminal 9.

Ground is supplied to time control unit terminal 8 through body grounds M28 and M54.

When a signal, or combination of signals, is received by the time control unit, the warning chime will sound.

## Ignition Key Warning Chime

With the key in the ignition switch, the ignition switch in the OFF position, and the driver door open, the warning chime will sound.

Power is supplied:

- from key switch terminal 1
- to time control unit terminal 4.

Ground is supplied:

- from front door switch LH terminal 2
- to time control unit terminal 2.

Front door switch LH terminal 3 is grounded through body grounds B13 and B19.

## Light Warning Chime

With ignition switch OFF, driver door open, and combination switch (lighting switch) in parking lamp (1ST) or ON (2ND) position, warning chime will sound.

Power is supplied:

- from combination switch (lighting switch) terminal 12
- to time control unit terminal 5.

Ground is supplied:

- from front door switch LH terminal 2
- to time control unit terminal 2.

Front door switch LH terminal 3 is grounded through body grounds B13 and B19.

## Seat Belt Warning Chime

With ignition switch turned ON and seat belt unfastened (seat belt buckle switch LH ON), warning chime will sound for approximately 6 seconds.

Ground is supplied:

- from seat belt buckle switch LH terminal 1
- to time control unit terminal 1.

Seat belt buckle switch LH terminal 2 is grounded through body grounds B13 and B19.

## WITH POWER DOOR LOCKS

The warning chime is controlled by the smart entrance control unit.

The warning chime is located in the smart entrance control unit.

Power is supplied at all times:

- through 10A fuse (No. 37, located in fuse and fusible link box)
- to smart entrance control unit terminal 10,
- through 10A fuse [No. 12, located in the fuse block (J/B)]

# WARNING CHIME

- to key switch terminal 2, and
- through 10A fuse (No. 38, located in the fuse and fusible link box)
- to combination switch (lighting switch) terminal 11.

With the ignition switch in the ON or START position, power is supplied:

- through 10A fuse [No. 10, located in the fuse block (J/B)]
- to smart entrance control unit terminal 33.

Ground is supplied to smart entrance control unit terminal 16 through body grounds M28 and M54.

When a signal, or combination of signals, is received by the smart entrance control unit, the warning chime will sound.

## Ignition Key Warning Chime

With the key in the ignition switch, the ignition switch in the OFF position, and the driver door open, the warning chime will sound.

Power is supplied:

- from key switch terminal 1
- to smart entrance control unit terminal 32.

Ground is supplied:

- from front door switch LH terminal 2
- to smart entrance control unit terminal 29.

Front door switch LH terminal 3 is grounded through body grounds B13 and B19.

## Light Warning Chime

With ignition switch OFF, driver door open, and combination switch (lighting switch) in parking lamp (1ST) or ON (2ND) position, warning chime will sound.

Power is supplied:

- from combination switch (lighting switch) terminal 12
- to smart entrance control unit terminal 34.

Ground is supplied:

- from front door switch LH terminal 2
- to smart entrance control unit terminal 29.

Front door switch LH terminal 3 is grounded through body grounds B13 and B19.

## Seat Belt Warning Chime

With ignition switch turned ON and seat belt unfastened (seat belt switch ON), warning chime will sound for approximately 6 seconds.

Ground is supplied:

- from seat belt buckle switch LH terminal 1
- to smart entrance control unit terminal 22.

Seat belt buckle switch LH terminal 2 is grounded through body grounds B13 and B19.

A

B

C

D

E

F

G

H

I

J

DI

L

M

# WARNING CHIME

EKS0039M

## Wiring Diagram — CHIME — WITHOUT POWER DOOR LOCKS

DI-CHIME-01

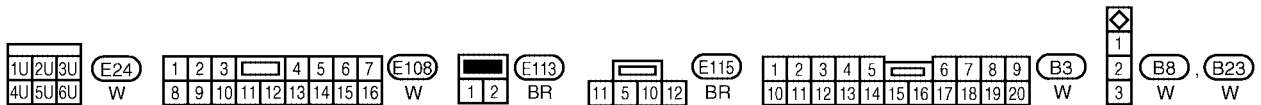
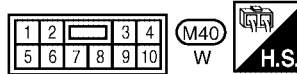
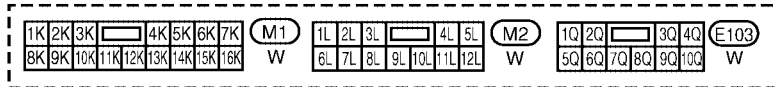
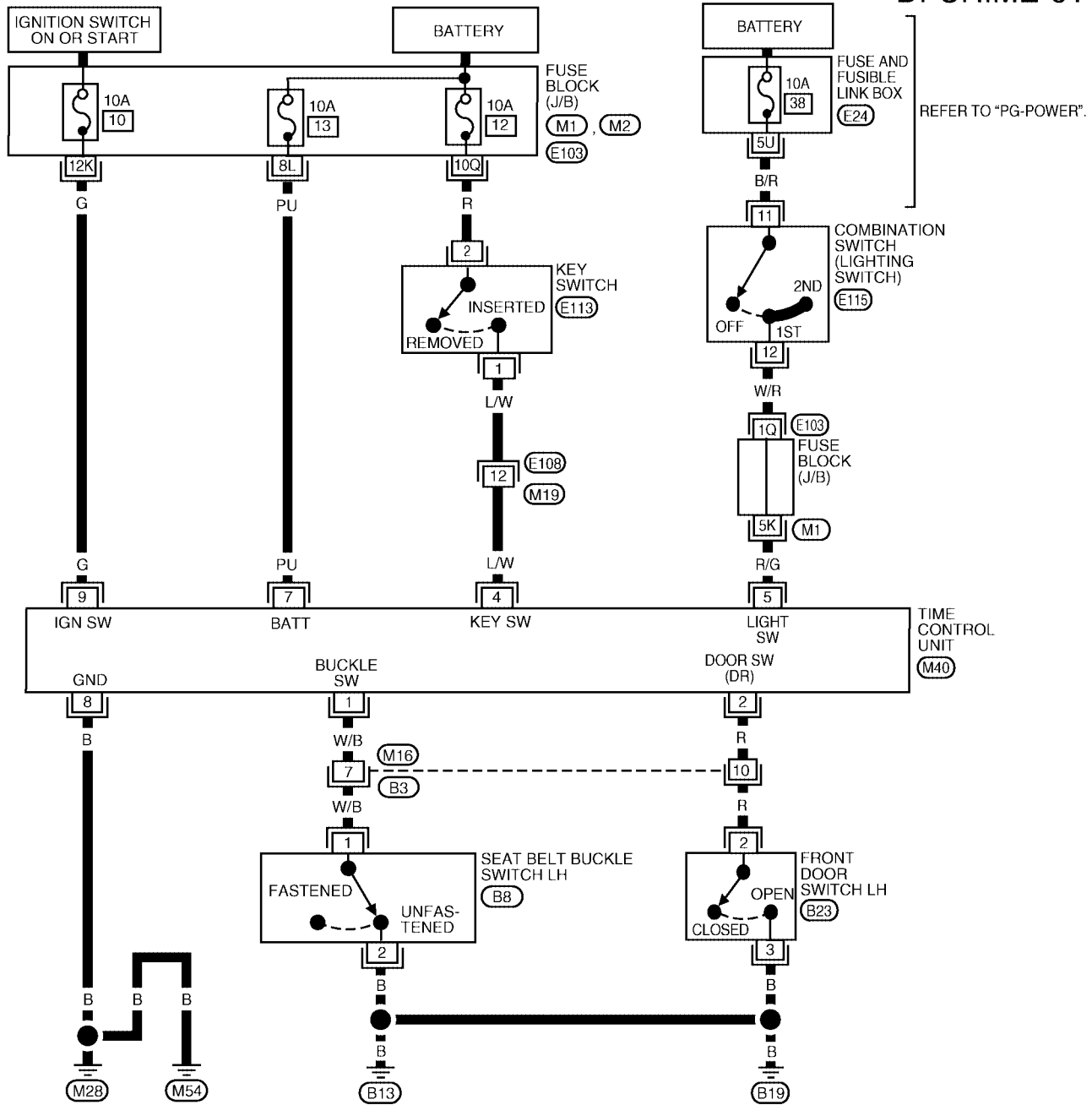

WKWA1626E

# WARNING CHIME

## WITH POWER DOOR LOCKS

DI-CHIME-02

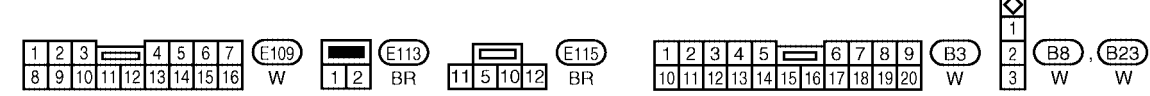
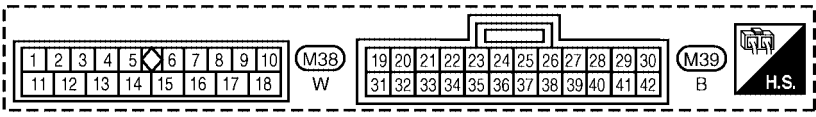
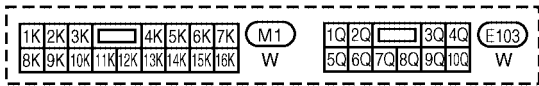
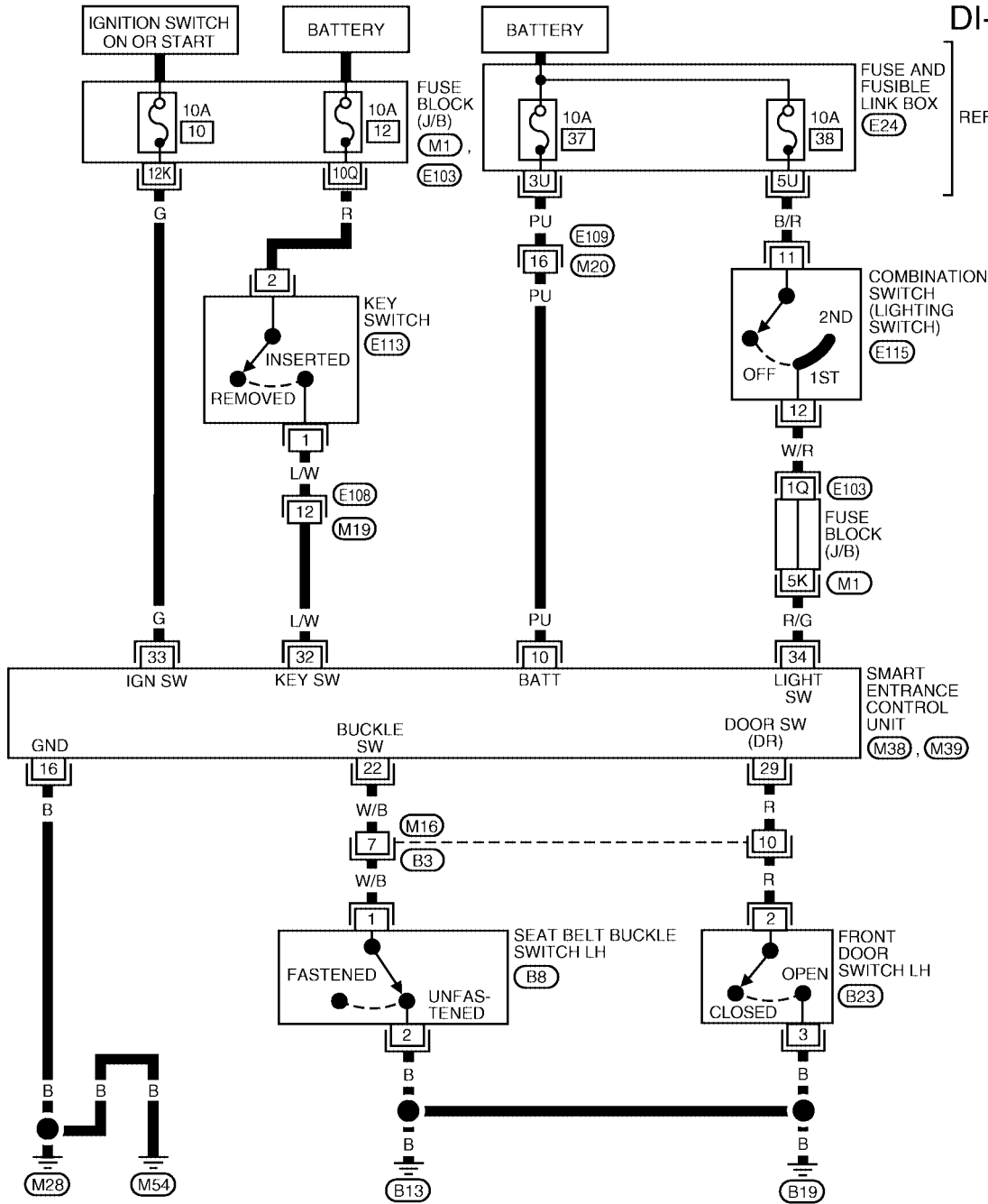

A  
B  
C  
D  
E  
F  
G  
H  
I  
J  
K  
L  
M

DI

# WARNING CHIME

EKS0039N

## CONSULT-II Function (BCM)

CONSULT-II can display each diagnostic item using the diagnostic test modes shown following.

BCM diagnostic test item	Diagnostic mode	Description
Inspection by part	WORK SUPPORT	Supports inspections and adjustments. Commands are transmitted to the BCM for setting the status suitable for required operation, input/output signals are received from the BCM and received data is displayed.
	DATA MONITOR	Displays BCM input/output data in real time.
	ACTIVE TEST	Operation of electrical loads can be checked by sending drive signal to them.
	SELF-DIAG RESULTS	Displays BCM self-diagnosis results.
	CAN DIAG SUPPORT MNTR	The result of transmit/receive diagnosis of CAN communication can be read.
	ECU PART NUMBER	BCM part number can be read.
	CONFIGURATION	Performs BCM configuration read/write functions.

## CONSULT-II BASIC OPERATION PROCEDURE (WITH POWER DOOR LOCKS)

### CAUTION:

If CONSULT-II is used with no connection of CONSULT-II CONVERTER, malfunctions might be detected in self-diagnosis depending on control unit which carries out CAN communication.

1. With the ignition switch OFF, connect CONSULT-II and CONSULT-II CONVERTER to the data link connector, then turn ignition switch ON.

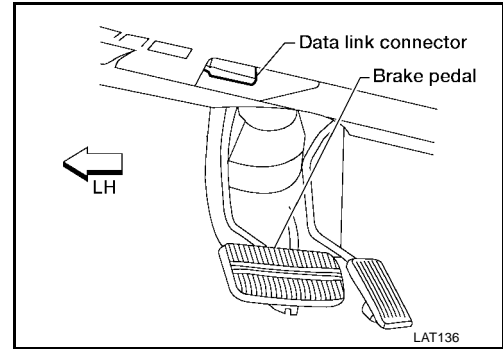

2. Touch "START (NISSAN BASED VHCL)".

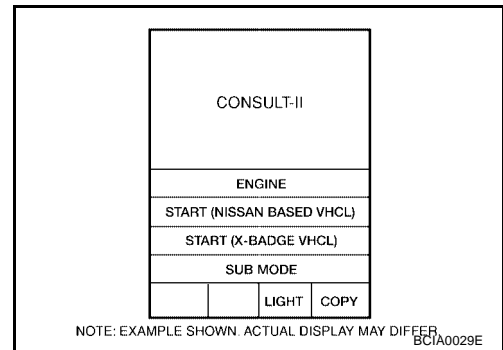

3. Touch "SMART ENTRANCE".

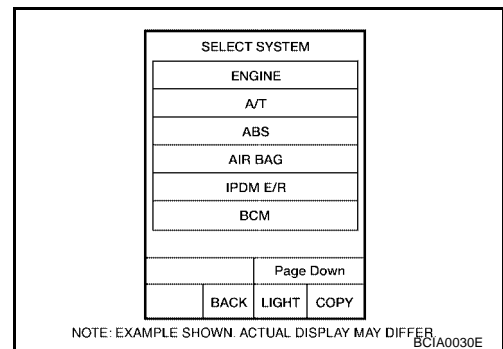

# WARNING CHIME

4. Touch “KEY WARN ALM”, “LIGHT WARN ALM” or “SEAT BELT ALM”.

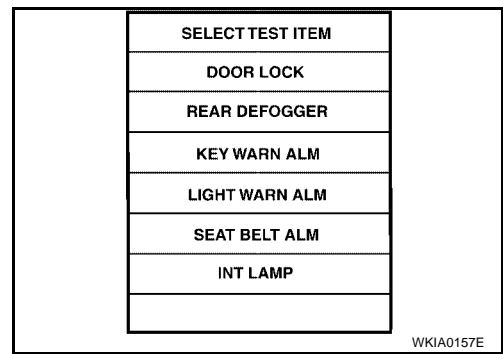

5. Select diagnosis mode. “DATA MONITOR” and “ACTIVE TEST” are available for the warning chime.

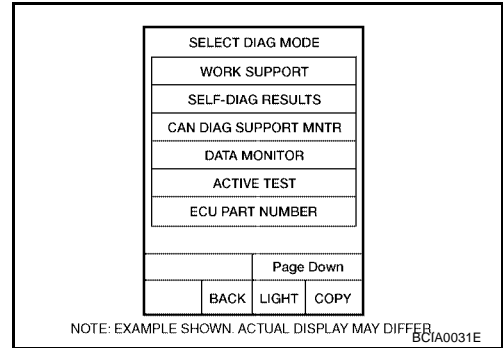

## CONSULT-II Application Items (With Power Door Locks) “KEY WARN ALARM”

EKS00390

### Data Monitor

Monitored Item	Description
IGN ON SW	Indicates [ON/OFF] condition of ignition switch.
KEY ON SW	Indicates [ON/OFF] condition of key switch.
DOOR SW-DR	Indicates [ON/OFF] condition of front door switch LH.

### Active Test

Test Item	Description
CHIME	This test is able to check key warning chime operation. Key warning chime sounds after touching “ON” on CONSULT-II screen.

## “LIGHT WARN ALM”

### Data Monitor

Monitored Item	Description
IGN ON SW	Indicates [ON/OFF] condition of ignition switch.
HD/LMP 1ST SW	Indicates [ON/OFF] condition of lighting switch.
DOOR SW-DR	Indicates [ON/OFF] condition of front door switch LH.

### Active Test

Test Item	Description
CHIME	This test is able to check light warning chime operation. Light warning chime sounds after touching “ON” on CONSULT-II screen.

## “SEAT BELT ALM”

### Data Monitor

Monitored Item	Description
IGN ON SW	Indicates [ON/OFF] condition of ignition switch.
SEAT BELT SW	Indicates [ON/OFF] condition of seat belt buckle switch LH.

# WARNING CHIME

## Active Test

Test Item	Description
CHIME	This test is able to check seat belt warning chime operation. Seat belt warning chime sounds after touching "ON" on CONSULT-II screen.

## Trouble Diagnoses (Without Power Door Locks) SYMPTOM CHART

EKS0039P

REFERENCE PAGE	<a href="#">DI-48</a>	<a href="#">DI-49</a>	<a href="#">DI-49</a>	<a href="#">DI-50</a>	<a href="#">DI-51</a>
SYMPTOM	POWER SUPPLY AND GROUND CIRCUIT CHECK	DIAGNOSTIC PROCEDURE 1 (LIGHTING SWITCH INPUT SIGNAL CHECK)	DIAGNOSTIC PROCEDURE 2 (KEY SWITCH INSERT/SIGNAL CHECK)	DIAGNOSTIC PROCEDURE 3 (SEAT BELT BUCKLE SWITCH LH CHECK)	DIAGNOSTIC PROCEDURE 4
Light warning chime does not activate.	X	X			X
Ignition key warning chime does not activate.	X		X		X
Seat belt warning chime does not activate.	X			X	X
All warning chimes do not activate.	X				X

X: Applicable

## POWER SUPPLY AND GROUND CIRCUIT CHECK

### Power Supply Circuit Check

Terminals			Ignition switch position		
(+)		(-)	OFF	ACC	ON
Connector	Terminal (Wire color)				
M40	7 (PU)	Ground	Battery voltage	Battery voltage	Battery voltage
M40	9 (G)	Ground	0V	0V	Battery voltage

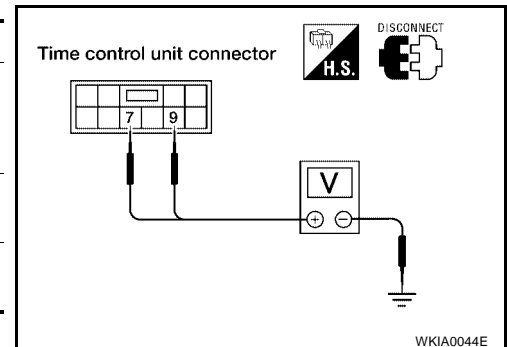



# WARNING CHIME

## Ground Circuit Check

Terminals		(-)	Continuity
(+) Terminal (Wire color)			
Connector	Terminal (Wire color)		
M40	8 (B)	Ground	Yes

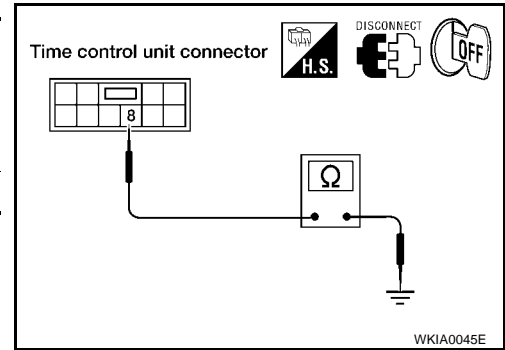

## DIAGNOSTIC PROCEDURE 1 (LIGHTING SWITCH INPUT SIGNAL CHECK)

### 1. CHECK LIGHTING SWITCH INPUT SIGNAL

Check voltage between time control unit terminal 5 and ground.

Terminals		(-)	Condition of lighting switch		
(+) Terminal (Wire color)			1st position	2nd position	OFF
Connector	Terminal (Wire color)				
M40	5 (R/G)	Ground	Battery voltage	Battery voltage	0V

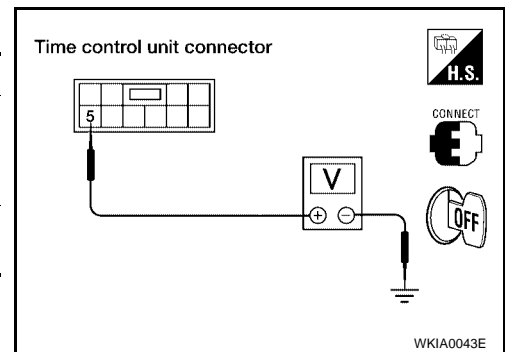

OK or NG

OK >> Combination switch (lighting switch) is OK.

NG >> Check the following.

- 10A fuse (No. 38, located in the fuse and fusible link box)
- Harness for open or short between control unit and combination switch (lighting switch)

## DIAGNOSTIC PROCEDURE 2 (KEY SWITCH INSERT SIGNAL CHECK)

### 1. CHECK KEY SWITCH INPUT SIGNAL

Check voltage between time control unit terminal 4 and ground.

Terminals		(-)	Condition of key switch	
(+) Terminal (Wire color)			Key inserted	Key removed
Connector	Terminal (Wire color)			
M40	4 (L/W)	Ground	Battery voltage	0V

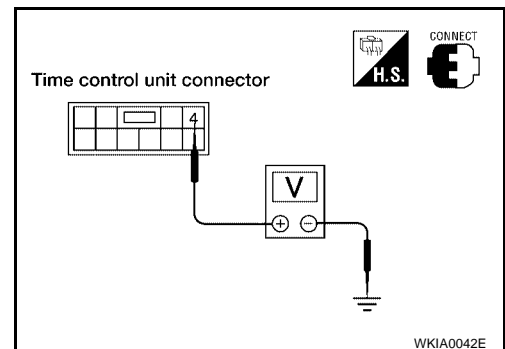

OK or NG

OK >> Key switch is OK.

NG >> GO TO 2.

# WARNING CHIME

## 2. CHECK KEY SWITCH

Check continuity between terminals 1 and 2.

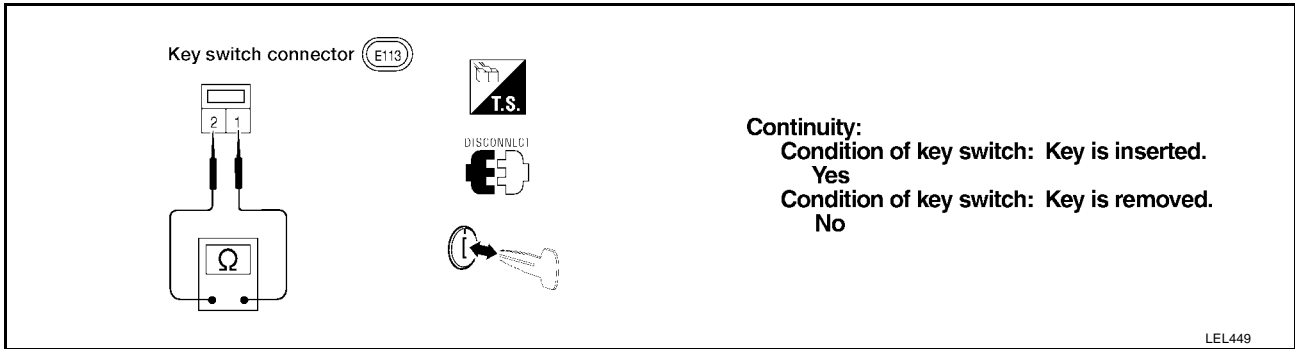

**OK or NG**

OK >> Check the following.

- 10A fuse [No. 12, located in fuse block (J/B)]
- Harness for open or short between key switch and fuse
- Harness for open or short between time control unit and key switch

NG >> Replace key switch.

## DIAGNOSTIC PROCEDURE 3 (SEAT BELT BUCKLE SWITCH LH CHECK)

### 1. CHECK SEAT BELT BUCKLE SWITCH LH INPUT SIGNAL

1. Turn ignition switch ON.
2. Check voltage between time control unit terminal 1 and ground.

Terminals		Condition of seat belt buckle switch LH		
(+)		(-)	Fastened	Unfastened
Connector	Terminal (Wire color)			
M40	1 (W/B)	Ground	Approx. 5V	0V

**OK or NG**

OK >> Seat belt buckle switch LH is OK.

NG >> GO TO 2.

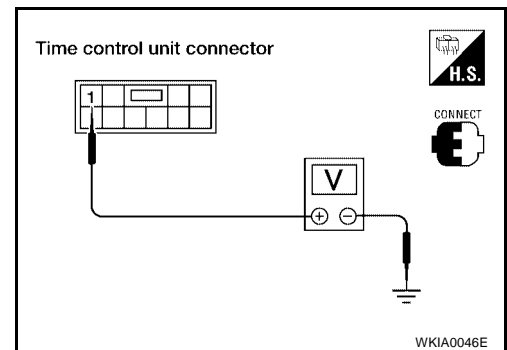

# WARNING CHIME

## 2. CHECK SEAT BELT BUCKLE SWITCH LH

Check continuity between terminals 1 and 2 when seat belt is fastened and unfastened.

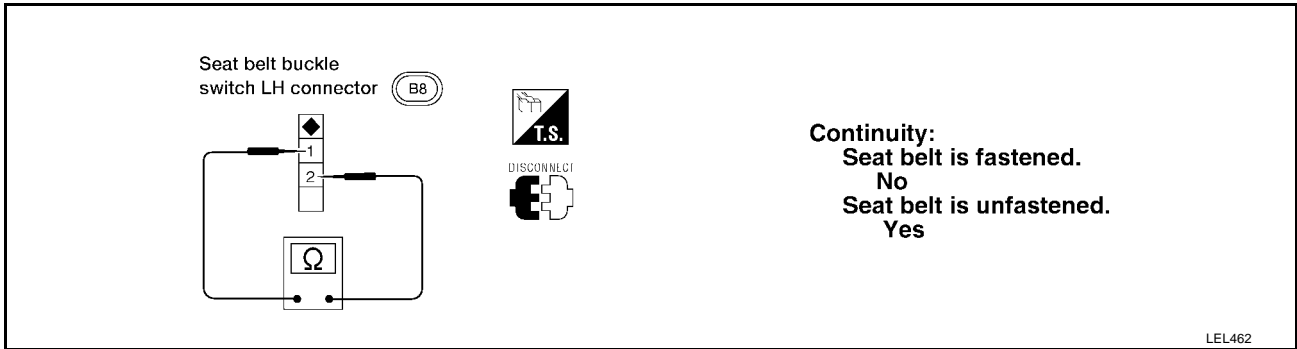

**OK or NG**

**OK** >> Check the following.

- Seat belt buckle switch LH ground circuit
- Harness for open between time control unit and seat belt buckle switch LH

**NG** >> Replace seat belt buckle switch LH.

## DIAGNOSTIC PROCEDURE 4

### 1. CHECK IGNITION ON SIGNAL

Check voltage between time control unit terminal 9 and ground.

Terminals		Ignition switch position		
(+)	(-)	OFF	ACC	ON
9 (G)	Ground	0V	0V	Battery voltage

**OK or NG**

**OK** >> GO TO 2.

**NG** >> Check the following.

- 10A fuse [No. 10, located in fuse block (J/B)]
- Harness for open or short between time control unit and fuse

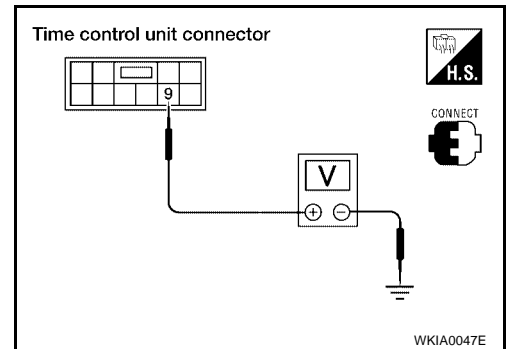

### 2. CHECK FRONT DOOR SWITCH LH INPUT SIGNAL

With ignition switch OFF, check voltage between time control unit terminal 2 and ground.

Terminals		Condition of driver's door		
(+) Connector		(-)	Closed	Open
M40	Terminal 2 (R)	Ground	Approx. 5V	0V

**OK or NG**

**OK** >> System is OK.

**NG** >> GO TO 3.

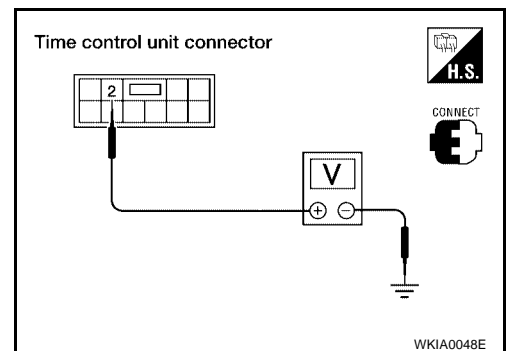

## WARNING CHIME

### 3. CHECK FRONT DOOR SWITCH LH

Check continuity between terminals 2 and 3.

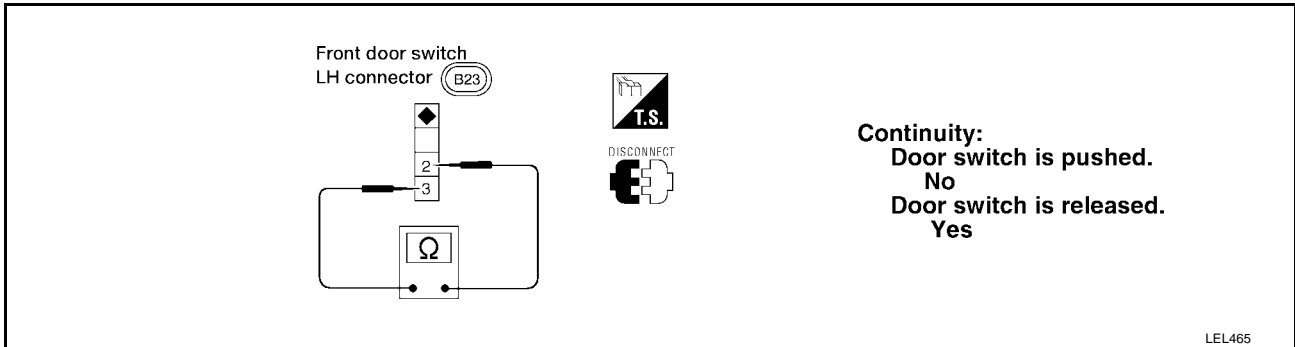

#### OK or NG

OK >> Check the following.

- Front door switch LH ground circuit and condition
- Harness for open or short between time control unit and front door switch LH

NG >> Replace front door switch LH.

# WARNING CHIME

## Trouble Diagnoses (With Power Door Locks) SYMPTOM CHART

EKS00390

REFERENCE PAGE	<a href="#">DI-53</a>	<a href="#">DI-54</a>	<a href="#">DI-55</a>	<a href="#">DI-56</a>	<a href="#">DI-57</a>
SYMPTOM	POWER SUPPLY AND GROUND CIRCUIT CHECK	DIAGNOSTIC PROCEDURE 1 (LIGHTING SWITCH INPUT SIGNAL CHECK)	DIAGNOSTIC PROCEDURE 2 (KEY SWITCH INSERT SIGNAL CHECK)	DIAGNOSTIC PROCEDURE 3 (SEAT BELT BUCKLE SWITCH LH CHECK)	DIAGNOSTIC PROCEDURE 4
Light warning chime does not activate.	X	X			X
Ignition key warning chime does not activate.	X		X		X
Seat belt warning chime does not activate.	X			X	X
All warning chimes do not activate.	X				X

X: Applicable

### POWER SUPPLY AND GROUND CIRCUIT CHECK

#### Power Supply Circuit Check

Terminals		Ignition switch position		
(+)	(-)	OFF	ACC	ON
10	Ground	Battery voltage	Battery voltage	Battery voltage

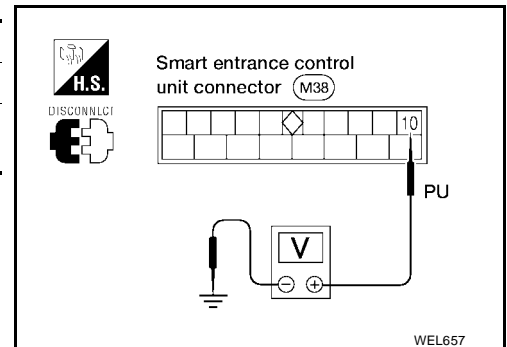

# WARNING CHIME

## Ground Circuit Check

Terminals		(-)	Continuity
(+) Connector			
Terminal (Wire color)			
M38	16 (B)	Ground	Yes

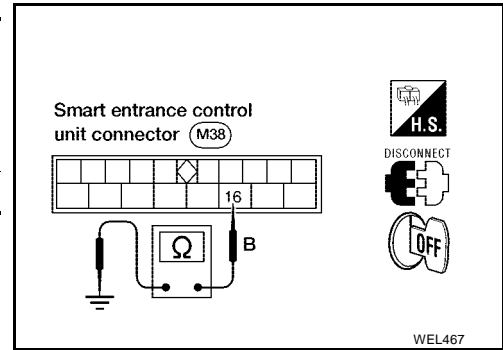

## DIAGNOSTIC PROCEDURE 1 (LIGHTING SWITCH INPUT SIGNAL CHECK)

### 1. CHECK LIGHTING SWITCH INPUT SIGNAL

#### With CONSULT-II

Check combination switch (lighting switch) ("HD/LMP 1ST SW") in "DATA MONITOR" mode with CONSULT-II.

DATA MONITOR	
MONITOR	
HD/LMP 1ST SW	OFF

When lighting switch is in 1st or 2nd position:  
**HD/LMP 1ST SW ON**

When lighting switch is in OFF position:  
**HD/LMP 1ST SW OFF**

SEL316W

#### Without CONSULT-II

Check voltage between smart entrance control unit terminal 34 and ground.

Smart entrance control unit connector (M39)

34 (R/G)

H.S. CONNECT OFF

WEL468

**Voltage [V]:**  
**Condition of lighting switch:**  
**Parking lamp (1ST) or ON (2ND)**  
**Approx. 12**  
**Condition of lighting switch: OFF**  
**0**

#### OK or NG

OK >> Combination switch (lighting switch) is OK.

NG >> Check the following.

- 10A fuse (No. 38, located in the fuse and fusible link box)
- Harness for open or short between smart entrance control unit and combination switch (lighting switch)

# WARNING CHIME

## DIAGNOSTIC PROCEDURE 2 (KEY SWITCH INSERT SIGNAL CHECK)

### 1. CHECK KEY SWITCH INPUT SIGNAL

#### With CONSULT-II

Check key switch ("KEY ON SW") in "DATA MONITOR" mode with CONSULT-II.

DATA MONITOR	
MONITOR	
KEY ON SW	ON

When key is inserted to ignition key cylinder:  
**KEY ON SW ON**

When key is removed from ignition key cylinder:  
**KEY ON SW OFF**

SEL315W

#### Without CONSULT-II

Check voltage between smart entrance control unit terminal 32 and ground.

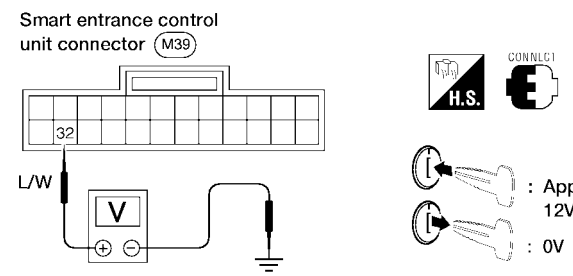

Smart entrance control unit connector (M39)

Voltage [V]:  
Condition of key switch: Key is inserted. Approx. 12  
Condition of key switch: Key is removed. 0

WEL469

OK or NG

- OK >> Key switch is OK.
- NG >> GO TO 2.

### 2. CHECK KEY SWITCH

Check continuity between terminals 1 and 2.

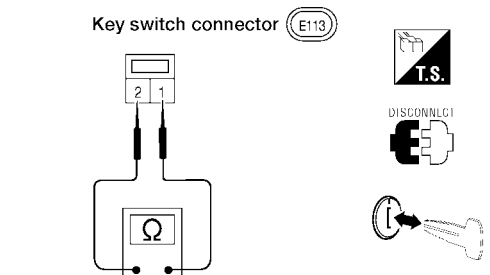

Key switch connector (E113)

Continuity:  
Condition of key switch: Key is inserted. Yes  
Condition of key switch: Key is removed. No

LEL449

OK or NG

- OK >> Check the following.
  - 10A fuse [No. 12, located in fuse block (J/B)]
  - Harness for open or short between key switch and fuse
  - Harness for open or short between smart entrance control unit and key switch
- NG >> Replace key switch.

# WARNING CHIME

## DIAGNOSTIC PROCEDURE 3 (SEAT BELT BUCKLE SWITCH LH CHECK)

### 1. CHECK SEAT BELT BUCKLE SWITCH LH INPUT SIGNAL

#### ④ With CONSULT-II

Check seat belt buckle switch LH ("SEAT BELT SW") in "DATA MONITOR" mode with CONSULT-II.

DATA MONITOR	
MONITOR	
SEAT BELT SW	ON

When seat belt is fastened:  
SEAT BELT SW OFF

When seat belt is released:  
SEAT BELT SW ON

LEL658

#### ⊗ Without CONSULT-II

1. Turn ignition switch ON.
2. Check voltage between smart entrance control unit terminal 22 and ground.

Smart entrance control unit connector (M39)

22

W/B

V

H.S.

CONNECT

ON

DISCONNECT

Voltage [V]:  
Condition of seat belt buckle switch LH: Fastened  
Approx. 5  
Condition of seat belt buckle switch LH: Unfastened  
0

WEL470

#### OK or NG

- OK >> Seat belt buckle switch LH is OK.  
NG >> GO TO 2.

### 2. CHECK SEAT BELT BUCKLE SWITCH LH

Check continuity between terminals 1 and 2 when seat belt is fastened and unfastened.

Seat belt buckle switch LH connector (B8)

1

2

Ω

I.S.

DISCONNECT

Continuity:  
Seat belt is fastened.  
No  
Seat belt is unfastened.  
Yes

LEL462

#### OK or NG

- OK >> Check the following.
- Seat belt buckle switch LH ground circuit
  - Harness for open between smart entrance control unit and seat belt buckle switch LH
- NG >> Replace seat belt buckle switch LH.



# WARNING CHIME

## DIAGNOSTIC PROCEDURE 4

### 1. CHECK IGNITION ON SIGNAL

#### With CONSULT-II

Check ignition switch ON signal ("IGN ON SW") in "DATA MONITOR" mode with CONSULT-II.

DATA MONITOR	
MONITOR	
IGN ON SW	ON

When ignition switch is ON:  
**IGN ON SW ON**

When ignition switch is OFF:  
**IGN ON SW OFF**

SEL318W

#### Without CONSULT-II

Check voltage between smart entrance control unit terminal 33 and ground.

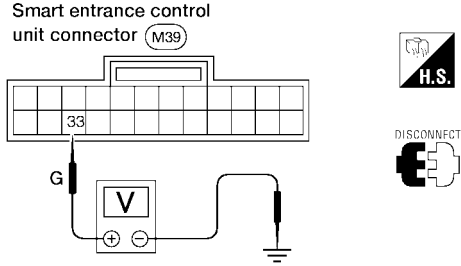

Terminals		Ignition switch position		
(+)	(-)	OFF	ACC	ON
33	Ground	0V	0V	Battery voltage

WEL471

#### OK or NG

OK >> GO TO 2.

NG >> Check the following.

- 10A fuse [No. 10, located in fuse block (J/B)]
- Harness for open or short between smart entrance control unit and fuse

# WARNING CHIME

## 2. CHECK FRONT DOOR SWITCH LH INPUT SIGNAL

### With CONSULT-II

Check front door switch LH signal ("DOOR SW-DR") in "DATA MONITOR" mode with CONSULT-II.

DATA MONITOR	
MONITOR	
DOOR SW-DR	OFF

When driver's door is open:  
**DOOR SW-DR ON**

When driver's door is closed:  
**DOOR SW-DR OFF**

SEL319W

### Without CONSULT-II

Check voltage between smart entrance control unit terminal 29 and ground.

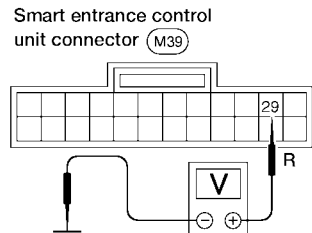

Smart entrance control unit connector (M39)

**H.S.**  
CONNECT

Voltage [V]:  
Condition of driver's door: **CLOSED**  
Approx. 5  
Condition of driver's door: **OPENED**  
0

WEL472

OK or NG

- OK >> GO TO 4.  
NG >> GO TO 3.

## 3. CHECK FRONT DOOR SWITCH LH

Check continuity between terminals 2 and 3.

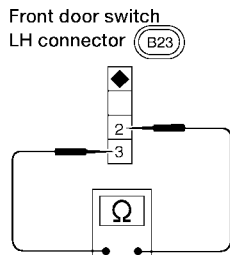

Front door switch LH connector (B23)

**T.S.**  
DISCONNECT

Continuity:  
Door switch is pushed.  
No  
Door switch is released.  
Yes

LEL465

OK or NG

- OK >> Check the following.
- Front door switch LH ground circuit and condition
  - Harness for open between smart entrance control unit and front door switch LH
- NG >> Replace front door switch LH.

# WARNING CHIME

## 4. CHECK WARNING CHIME

### With CONSULT-II

Perform "CHIME" in "ACTIVE TEST" mode with CONSULT-II.

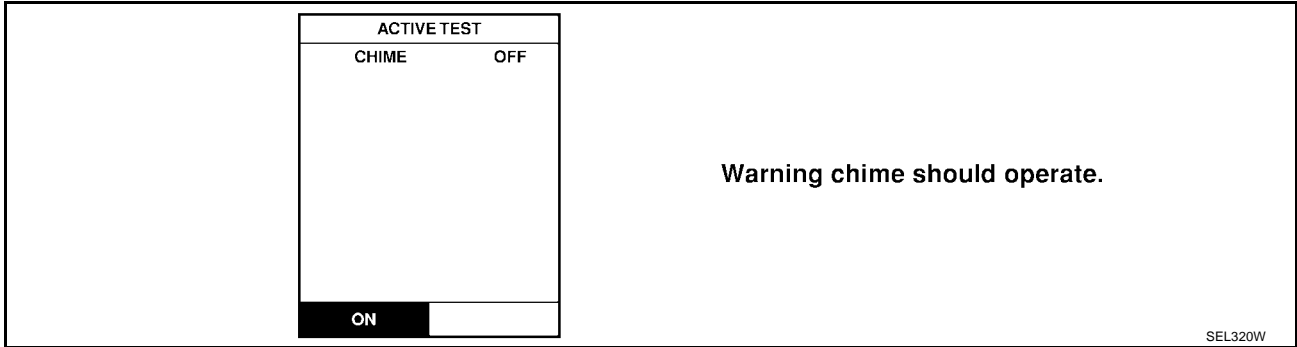

### OK or NG

- OK >> System is OK.
- NG >> Replace smart entrance control unit.

A  
B  
C  
D  
E  
F  
G  
H  
I  
J  
DI  
L  
M

## BOARD COMPUTER

### System Description FUNCTION

The board computer can indicate the following items.

- Outside air temperature
- DTE (distance to empty)
- Trip distance
- Trip time
- Average fuel consumption
- Average vehicle speed

### OUTSIDE AIR TEMPERATURE INDICATION

The outside air temperature indication is displayed while the ignition switch is in the ON position.

Signal is supplied

- through ambient sensor terminal 1
- to combination meter (board computer) terminal 20.

Indication range is between -30 and 55°C (-22 and 131°F). When outside temperature is less than 3°C (37°F), display shows ICY. In this case, the display will change to the outside air temperature mode even though the display is showing a different mode. When outside temperature is more than 55°C (131°F), indication will be blank. The indicated temperature is not affected by engine heat. It changes only when one of the following conditions exists.

- When vehicle speed is more than 20 km/h (12 MPH).
- The ignition switch has been turned OFF for more than 3.5 hours.
- When outside air temperature is less than the indicated temperature.

### DTE (DISTANCE TO EMPTY) INDICATION

The range indication provides the driver with an estimation of the distance that can be driven before refueling. The range is calculated by signals from the fuel level sensor unit (fuel remaining), ECM (fuel consumption) and vehicle speed sensor. The indication will be refreshed every 30 seconds. When fuel remaining is less than approximately 10 ℓ (10 5/8 US quarts), the indication will blink as a warning. If the fuel remaining is less than approximately 8 ℓ (8 1/2 US quarts), the indication will show "---". In this case, the display will change to the DTE mode even though the display is showing a different mode. When the battery is disconnected and reconnected, DTE mode will display "---" until the vehicle is driven 500 miles (804.5 km).

### TRIP DISTANCE

Trip distance is calculated by signal from the vehicle speed sensor. If trip distance is reset, trip time will be reset at the same time.

### TRIP TIME

Trip time displays cumulative ignition switch ON time. If trip time is reset, trip distance will be reset at the same time.

### AVERAGE FUEL CONSUMPTION

Average fuel consumption indication is calculated by signals from the vehicle speed sensor and the ECM (fuel consumption). The indication will be refreshed every 30 seconds.

### AVERAGE VEHICLE SPEED

Average vehicle speed indication is calculated by running distance and running time. The indication will be refreshed every 30 seconds. If average vehicle speed is reset, average fuel consumption will be reset at the same time. After resetting, the display will show "---" for 30 seconds.

### HOW TO CHANGE/RESET INDICATION

Indication can be changed in the following order by momentarily depressing the board computer switch.

Outside air temperature → DTE → Trip distance → Trip time → Average fuel consumption → Average vehicle speed.

Holding the switch for more than 0.8 second will reset the indication of the currently displayed mode (trip distance, trip time, average vehicle speed or average fuel consumption).

# BOARD COMPUTER

---

**NOTE:**

After the display changes automatically, the indication can be changed to the last mode by pushing the board computer switch.

## **CAN Communication System Description**

EKS00654

Refer to [LAN-4, "CAN COMMUNICATION"](#) .

A

B

C

D

E

F

G

H

I

J

**DI**

L

M

# BOARD COMPUTER

EKS00655

## Wiring Diagram — B/COMP —

DI-B/COMP-01

— : DATA LINE

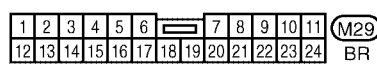
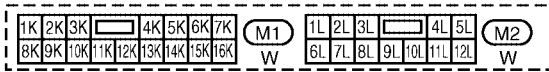
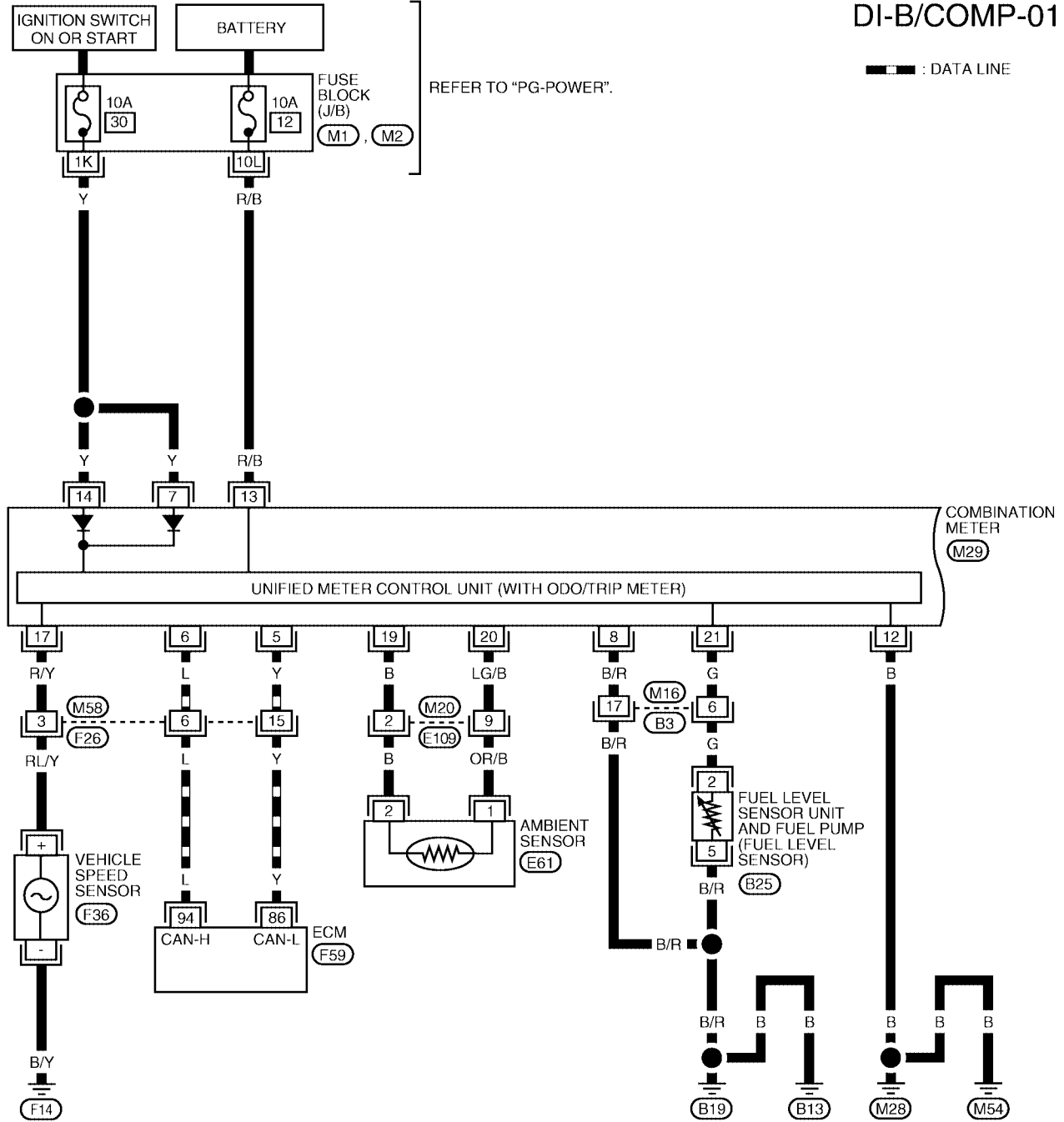

REFER TO THE FOLLOWING.  
 (F59) - ELECTRICAL UNITS

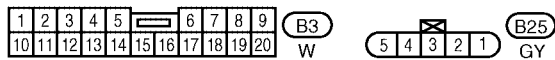
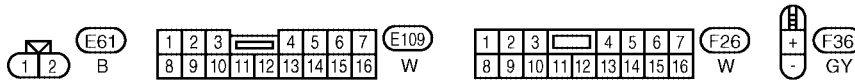

WKWA1658E

# BOARD COMPUTER

EKS00656

## Trouble Diagnoses SEGMENT CHECK

The board computer segment display can be checked by entering combination meter self-diagnostic mode. Refer to [DI-16, "SELF-DIAGNOSIS FUNCTION"](#).

### PRELIMINARY CHECK

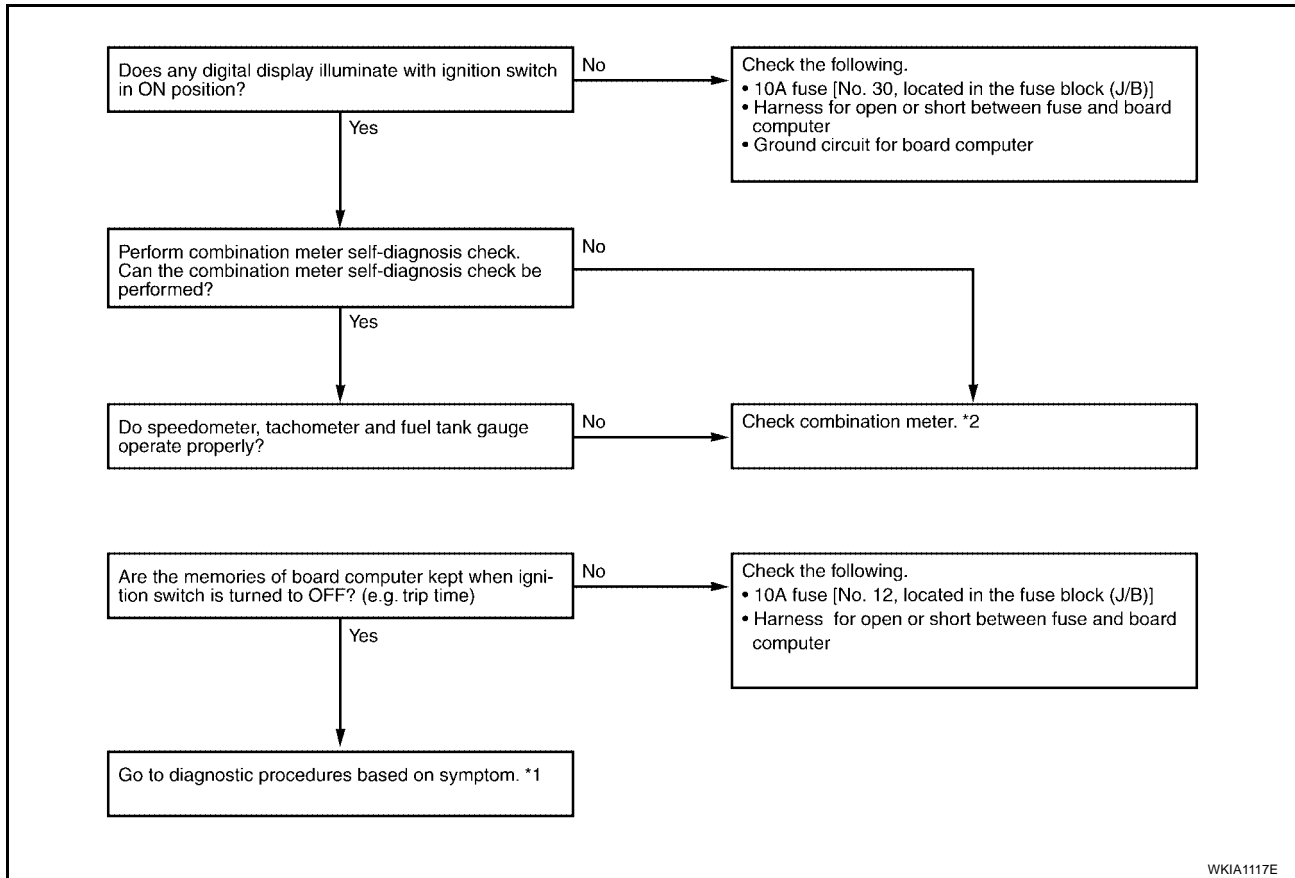

\*1 [DI-63, "DIAGNOSIS PROCEDURE"](#) \*2 [DI-17, "PRELIMINARY CHECK"](#)

### DIAGNOSIS PROCEDURE

Symptom	Possible cause	Repair order
Outside air temperature display is not displayed properly. (It may take a short time to steady the indication after ignition switch is turned ON.)  <b>NOTE:</b> If the meter is powered up with the ambient sensor disconnected, outside air temperature display will show "---" even if the sensor is reconnected. In this case, with the sensor connected, disconnect and reconnect the battery, then the correct temperature will be displayed.	1. Ambient sensor 2. Ambient sensor circuit 3. Vehicle speed sensor signal	1. Check ambient sensor. 2. Check harness for open or short between ambient sensor and board computer. 3. Check harness for open or short between combination meter terminal 17 and vehicle speed sensor.
DTE (distance to empty) is not displayed properly.)	1. Average fuel consumption display 2. Fuel tank gauge signal circuit.	1. Make sure fuel consumption is displayed properly. If NG, check fuel consumption display. 2. Make sure fuel gauge operates properly. If NG, check fuel gauge.
Trip distance is not indicated properly.	1. Vehicle speed sensor signal circuit	1. Check harness for open or short between combination meter terminal 17 and vehicle speed sensor.

# BOARD COMPUTER

Symptom	Possible cause	Repair order
Trip time is not indicated properly.	1. Fuse	1. 10A fuse [No. 12 (located in fuse block (J/B))]. Verify battery voltage is present at combination meter terminal 13.
Average fuel consumption is not displayed properly.	1. Trip distance display 2. Fuel consumption signal	1. Check harness for open or short between combination meter terminal 17 and vehicle speed sensor. 2. Check CAN lines for open or short between ECM and combination meter.
Average vehicle speed is not indicated properly.	1. Trip distance display 2. Trip time display	1. Check harness for open or short between combination meter terminal 17 and vehicle speed sensor. 2. Make sure trip time is displayed properly. If NG, check trip time display.

## Electrical Components Inspection AMBIENT SENSOR

EKS00657

After disconnecting ambient sensor harness connector, measure resistance between terminals 2 and 1 at sensor harness side, using the table below.

Temperature °C (°F)	Resistance kΩ
-15 (5)	12.73
-10 (14)	9.92
-5 (23)	7.80
0 (32)	6.19
5 (41)	4.95
10 (50)	3.99
15 (59)	3.24
20 (68)	2.65
25 (77)	2.19
30 (86)	1.81
35 (95)	1.51
40 (104)	1.27
45 (113)	1.07

If NG, replace ambient sensor.

