

# CO

## SECTION

# ENGINE COOLING SYSTEM

A

CO

C

D

E

## CONTENTS

<b>QG18DE</b>	<b>SERVICE DATA AND SPECIFICATIONS (SDS) ..... 20</b>
<b>PRECAUTIONS ..... 3</b>	Capacity ..... 20
Precautions For Liquid Gasket ..... 3	Thermostat ..... 20
<b>REMOVAL OF LIQUID GASKET ..... 3</b>	Radiator ..... 20
LIQUID GASKET APPLICATION PROCEDURE... 3	
<b>PREPARATION ..... 4</b>	
Special Service Tools ..... 4	
<b>OVERHEATING CAUSE ANALYSIS ..... 5</b>	
Overheating Cause Analysis ..... 5	
<b>COOLING SYSTEM ..... 7</b>	
Cooling Circuit ..... 7	
<b>ENGINE COOLANT ..... 8</b>	
System Check ..... 8	
CHECKING COOLING SYSTEM HOSES ..... 8	
CHECKING RESERVOIR LEVEL ..... 8	
CHECKING COOLING SYSTEM FOR LEAKS.... 8	
CHECKING RADIATOR ..... 8	
CHECKING RADIATOR CAP ..... 9	
Refilling Engine Coolant ..... 9	
<b>WATER PUMP ..... 10</b>	
Removal and Installation ..... 10	
Inspection ..... 11	
<b>THERMOSTAT AND THERMOSTAT HOUSING ..... 12</b>	
Removal and Installation ..... 12	
<b>REMOVAL ..... 12</b>	
INSPECTION AFTER REMOVAL ..... 12	
<b>INSTALLATION ..... 13</b>	
<b>RADIATOR ..... 14</b>	
Removal and Installation ..... 14	
<b>REMOVAL ..... 14</b>	
<b>INSTALLATION ..... 14</b>	
Disassembly and Assembly ..... 15	
<b>PREPARATION ..... 15</b>	
DISASSEMBLY ..... 15	
<b>ASSEMBLY ..... 16</b>	
Inspection ..... 18	
<b>COOLING FAN ..... 19</b>	
Disassembly and Assembly Radiator Cooling Fan.. 19	
DISASSEMBLY ..... 19	
<b>ASSEMBLY ..... 19</b>	
	<b>QR25DE</b>
	<b>PRECAUTIONS ..... 21</b>
	Precautions For Liquid Gasket ..... 21
	<b>REMOVAL OF LIQUID GASKET ..... 21</b>
	LIQUID GASKET APPLICATION PROCEDURE.. 21
	<b>PREPARATION ..... 22</b>
	Special Service Tools ..... 22
	<b>OVERHEATING CAUSE ANALYSIS ..... 23</b>
	Troubleshooting Chart ..... 23
	<b>COOLING SYSTEM ..... 25</b>
	Cooling Circuit ..... 25
	<b>ENGINE COOLANT ..... 26</b>
	System Check ..... 26
	CHECKING COOLING SYSTEM HOSES ..... 26
	CHECKING RESERVOIR LEVEL ..... 26
	CHECKING COOLING SYSTEM FOR LEAKS... 26
	CHECKING RADIATOR ..... 26
	CHECKING RADIATOR CAP ..... 27
	Refilling Engine Coolant ..... 27
	<b>WATER PUMP ..... 28</b>
	Removal and Installation ..... 28
	<b>REMOVAL ..... 28</b>
	INSPECTION AFTER REMOVAL ..... 29
	<b>INSTALLATION ..... 29</b>
	INSPECTION AFTER INSTALLATION ..... 29
	<b>THERMOSTAT AND THERMOSTAT HOUSING ..... 30</b>
	Removal and Installation ..... 30
	<b>REMOVAL ..... 30</b>
	INSPECTION AFTER REMOVAL ..... 31
	<b>INSTALLATION ..... 31</b>
	<b>RADIATOR ..... 32</b>
	Removal and Installation ..... 32
	<b>REMOVAL ..... 32</b>
	<b>INSTALLATION ..... 32</b>

F

G

H

I

J

K

L

M

Disassembly and Assembly .....	33	<b>SERVICE DATA AND SPECIFICATIONS (SDS) .....</b>	<b>38</b>
PREPARATION .....	33	Capacity .....	38
DISASSEMBLY .....	33	Thermostat .....	38
ASSEMBLY .....	34	Water Control Valve .....	38
Inspection .....	36	Radiator .....	38
<b>COOLING FAN .....</b>	<b>37</b>		
Disassembly and Assembly .....	37		
DISASSEMBLY .....	37		
ASSEMBLY .....	37		

## PRECAUTIONS

### Precautions For Liquid Gasket REMOVAL OF LIQUID GASKET

- After removing the bolts and nuts, disconnect and remove the sealant using Tool.

**Tool number** : KV10111100 (J-37228)

**CAUTION:**

**Be careful not to damage the mating surfaces.**

- In areas where the cutter is difficult to use, use a plastic hammer to lightly tap the liquid gasket applied area.

**CAUTION:**

**If for some unavoidable reason a tool such as a flat-blade screwdriver is used, be careful not to damage the mating surfaces.**

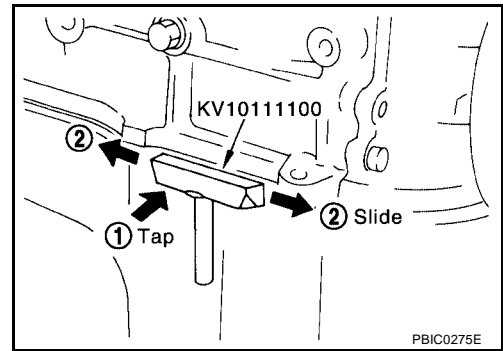

### LIQUID GASKET APPLICATION PROCEDURE

- Using a scraper, remove the old sealant adhering to the application surface and the mating surface.
- Remove the old sealant completely from the groove of the application surface, mounting bolts, and bolt holes.
- Thoroughly clean the application surface and the mating surface to remove adhering moisture, grease and foreign material.
- Attach the sealant tube to the tube presser.

**Use Genuine RTV Silicone Sealant or equivalent. Refer to [GI-46. "RECOMMENDED CHEMICAL PRODUCTS AND SEALANTS"](#) .**

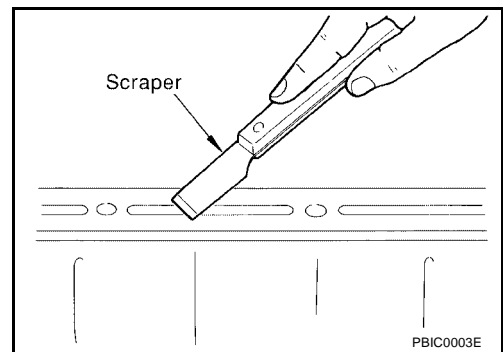

- Apply the sealant without breaks to the specified location with the specified dimensions.
- If there is a groove for the sealant application, apply the sealant to the groove.

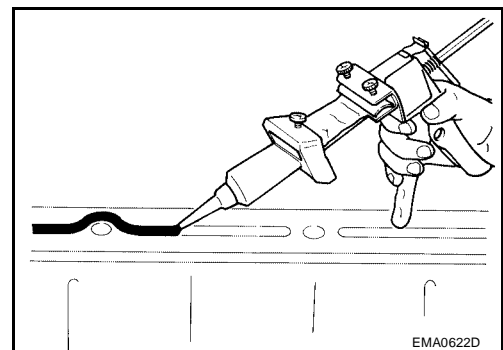

- As for the bolt holes, normally apply the sealant inside the holes. Occasionally, it should be applied outside the holes.
- Within five minutes of sealant application, install the mating component.
- If the sealant protrudes, wipe it off immediately.
- Do not retighten after the installation.
- After 30 minutes or more have passed from the installation, fill the engine with the specified oil and coolant. Refer to [MA-13. "RECOMMENDED FLUIDS AND LUBRICANTS"](#) .

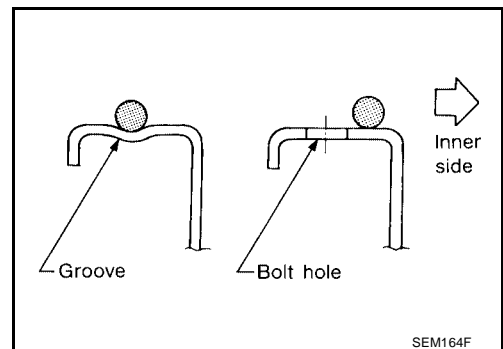

# PREPARATION

[QG18DE]



PFP:00002

EBS00CH2

## PREPARATION

### Special Service Tools

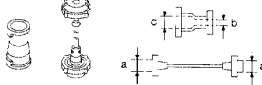
The actual shapes of Kent-Moore tools may differ from those of special service tools illustrated here.

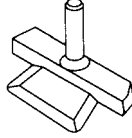
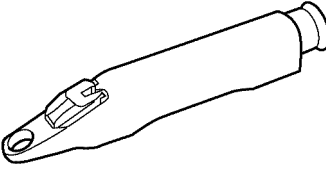
Tool number (Kent-Moore No.) Tool name	Image	Description
EG17650301 (J33984-A) Radiator cap tester adapter	 <p style="text-align: center;">NT564</p>	Adapting radiator cap tester to radiator filler neck <b>a: 28 (1.10) via.</b> <b>b: 31.4 (1.236) via.</b> <b>c: 41.3 (1.626) via.</b> Unit: mm (in)
KV99103510 ( — ) Radiator plate pliers A	 <p style="text-align: center;">S-NT224</p>	Installing radiator upper and lower tanks
KV99103520 ( — ) Radiator plate pliers B	 <p style="text-align: center;">S-NT225</p>	Removing radiator upper and lower tanks
KV10111100 (J-37228) Seal cutter	 <p style="text-align: center;">NT046</p>	Removing sealant
— (J-23688) Engine coolant refractometer	 <p style="text-align: center;">WBIA0539E</p>	Checking concentration of ethylene glycol in engine coolant

# OVERHEATING CAUSE ANALYSIS

[QG18DE]

## OVERHEATING CAUSE ANALYSIS

PFP:00012

### Overheating Cause Analysis

EBS00CH3

	Symptom		Check items			
Cooling system parts malfunction	Poor heat transfer	Water pump malfunction	Worn or loose drive belt	—	CO	
		Thermostat stuck closed	Coolant circulation			
		Damaged fins	Dust contamination or paper clogging			
			Mechanical damage			
	Reduced air flow	Clogged radiator cooling tube	Excess foreign material (rust, dirt, sand, etc.)	—	C	
		Cooling fan does not operate	Engine cooling fans			
		High resistance to fan rotation				
	Damaged fan blades					
	Damaged radiator shroud	—	—	—	D	
	Improper coolant mixture ratio	—	—	—	E	
	Poor coolant quality	—	—	—	F	
	Insufficient coolant	Coolant leaks	Cooling hose	Loose clamp	—	G
				Cracked hose		
			Water pump	Poor sealing		
				Radiator cap	Loose	
Poor sealing						
Radiator			O-ring for damage, deterioration or improper fitting			
		Cracked radiator tank				
		Cracked radiator core				
Reservoir tank	Cracked reservoir tank	—	—	H		
Overflowing reservoir tank	Exhaust gas leaks into cooling system	Cylinder head deterioration	—	I		
		Cylinder head gasket deterioration				

# OVERHEATING CAUSE ANALYSIS

[QG18DE]

	Symptom		Check items		
Except cooling system parts malfunction	Over heating engine	Overload on engine	Abusive driving	High engine RPM under no load	
				Driving in low gear for extended time	
				Driving at extremely high speed	
			Powertrain system malfunction	—	
			Installed improper size wheels and tires		
			Dragging brakes		
	Blocked or restricted air flow	Blocked or restricted air flow	Blocked bumper	—	Mud, debris, or paper clogging
			Blocked radiator grille	Installed car brassiere	
			Blocked radiator	—	
			Blocked condenser	—	
Installed large fog lamp			—		

# COOLING SYSTEM

[QG18DE]

## COOLING SYSTEM

PF2:21020

### Cooling Circuit

EBS00CH4

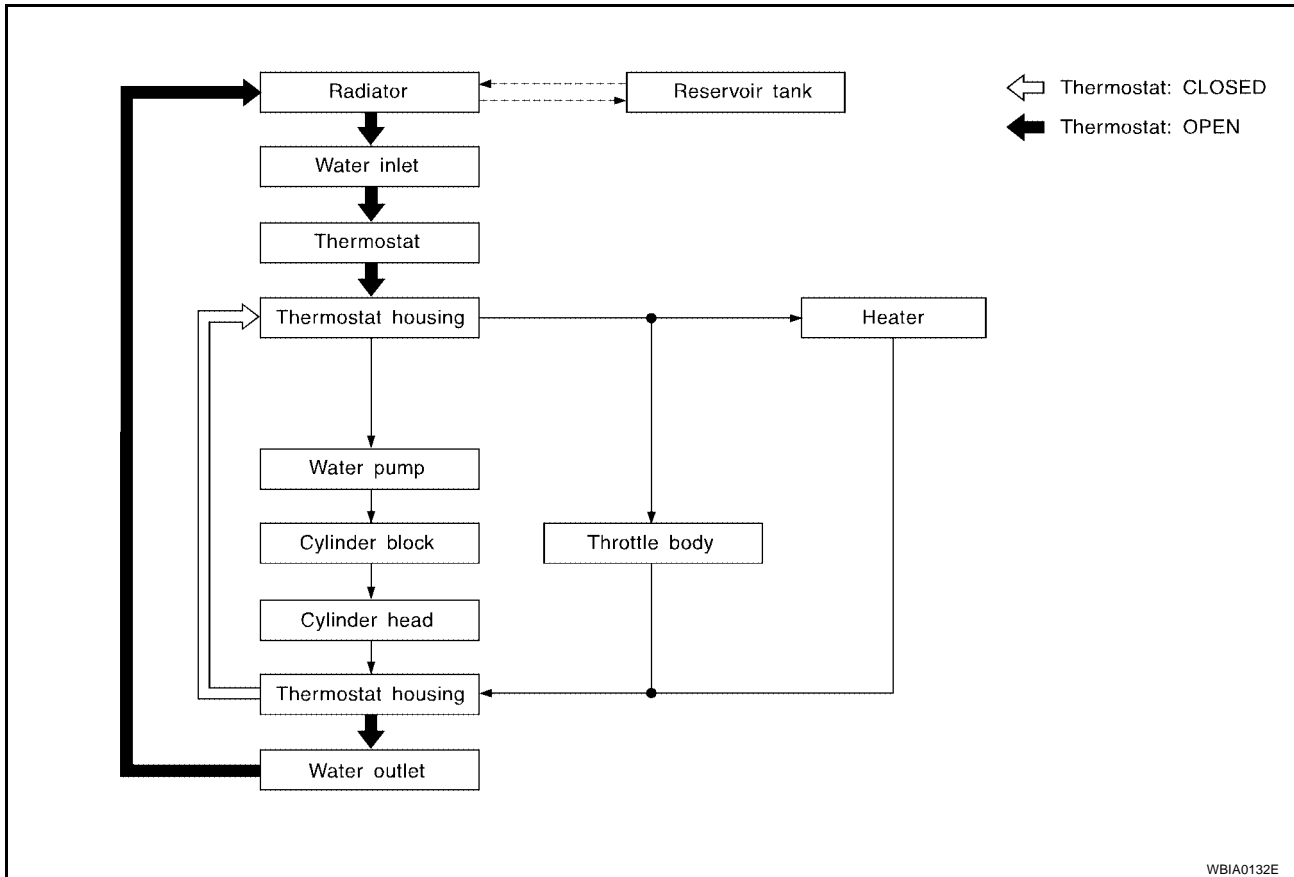

WBIA0132E

A

CO

C

D

E

F

G

H

I

J

K

L

M

## ENGINE COOLANT

### System Check

#### **WARNING:**

Never remove the radiator cap when the engine is hot. Serious burns could occur from high pressure fluid escaping from the radiator.

Wrap a thick cloth around the cap. Slowly push down and turn it a quarter turn to allow built-up pressure to escape. Carefully remove the cap by pushing down and turning it all the way.

### CHECKING COOLING SYSTEM HOSES

Check hoses for the following:

- Improper attachment
- Leaks
- Cracks
- Damage
- Loose connections
- Chafing
- Deterioration

### CHECKING RESERVOIR LEVEL

- Check if the reservoir tank coolant level is within MIN to MAX when the engine is cool.
- Adjust coolant level if it is too much or too little.

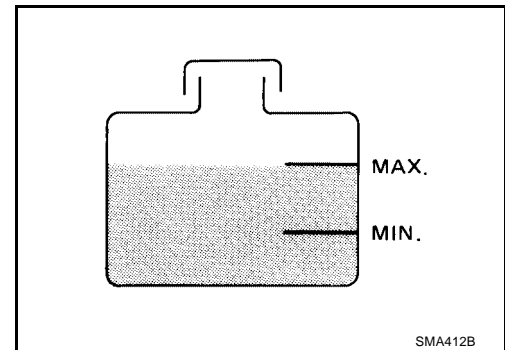

### CHECKING COOLING SYSTEM FOR LEAKS

To check for leakage, apply pressure to the cooling system using Tool.

**Testing pressure : 157 kPa (1.6 kg/cm<sup>2</sup> , 23 psi)**

#### **WARNING:**

Never remove the radiator cap when the engine is hot. Serious burns could occur from high pressure coolant escaping from the radiator.

#### **CAUTION:**

Higher pressure than specified may cause radiator damage.

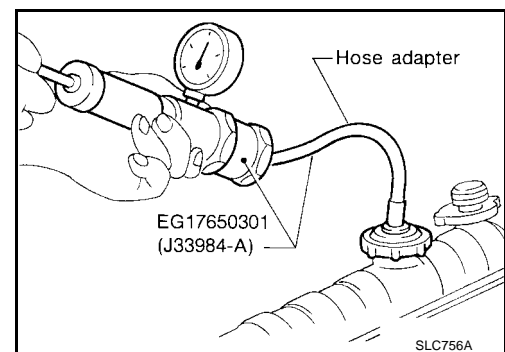

### CHECKING RADIATOR

Check radiator for mud or clogging. If necessary, clean radiator as follows:

- Be careful not to bend or damage the radiator fins.
  - When radiator is cleaned without removal, remove all surrounding parts such as cooling fan, radiator shroud and horns. Then tape the harness and connectors to prevent water from entering.
1. Apply water by hose to the back side of the radiator core vertically downward.
  2. Apply water again to all radiator core surfaces once per minute.
  3. Stop washing when clear water flows off the radiator.
  4. Blow air into the back side of radiator core vertically downward.
    - Use compressed air lower than 490 kPa (5 kg/cm<sup>2</sup> , 71 psi) and keep distance more than 300 mm (11.8 in).



5. Blow air again into all the radiator core surfaces once per minute until no water sprays out.
6. Check for leakage.

## CHECKING RADIATOR CAP

1. Inspect the radiator cap.
  - Replace the cap if the metal plunger cannot be seen around the edge of the black rubber gasket.
  - Replace the cap if deposits of waxy residue or other foreign material are on the black rubber gasket or the metal retainer.

**NOTE:**

Thoroughly wipe out the radiator filler neck to remove any waxy residue or foreign material.

2. Pull the negative-pressure valve to open it and check that it closes completely when released.
  - Check that there is no dirt or damage on the valve seat of the radiator cap negative-pressure valve.
  - Check that there are no abnormalities in the opening and closing conditions of the negative-pressure valve.

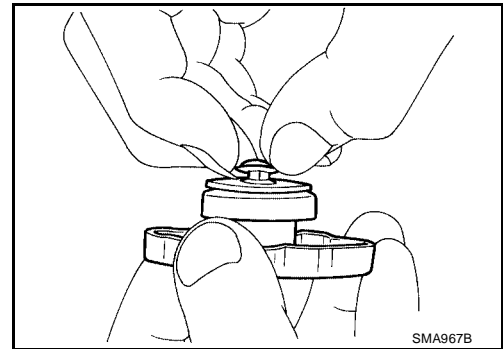

3. Check radiator cap relief pressure using Tool.

**Tool number : EG17650301 (J-33984-A)**

**Standard: 78 – 98 kPa (0.8 – 1.0 kg/cm<sup>2</sup> , 11 – 14 psi)**

**Limit: 59 kPa (0.6 kg/cm<sup>2</sup> , 9 psi)**

- When connecting the radiator cap to the tester, apply water or coolant to the cap seal surface.
- Replace the radiator cap if there is an abnormality in the negative-pressure valve, or if the open-valve pressure is outside of the standard values.

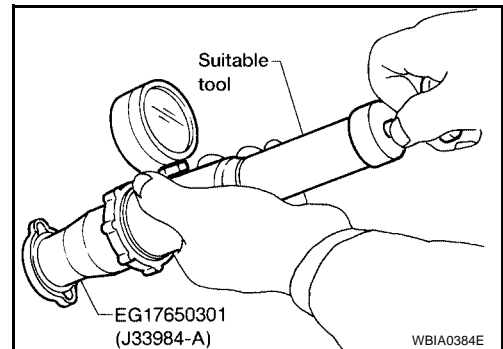

## Refilling Engine Coolant

EBS00CH6

Changing the engine coolant is part of the required maintenance of the engine. Refer to [MA-16. "Changing Engine Coolant"](#) .

## WATER PUMP

### Removal and Installation

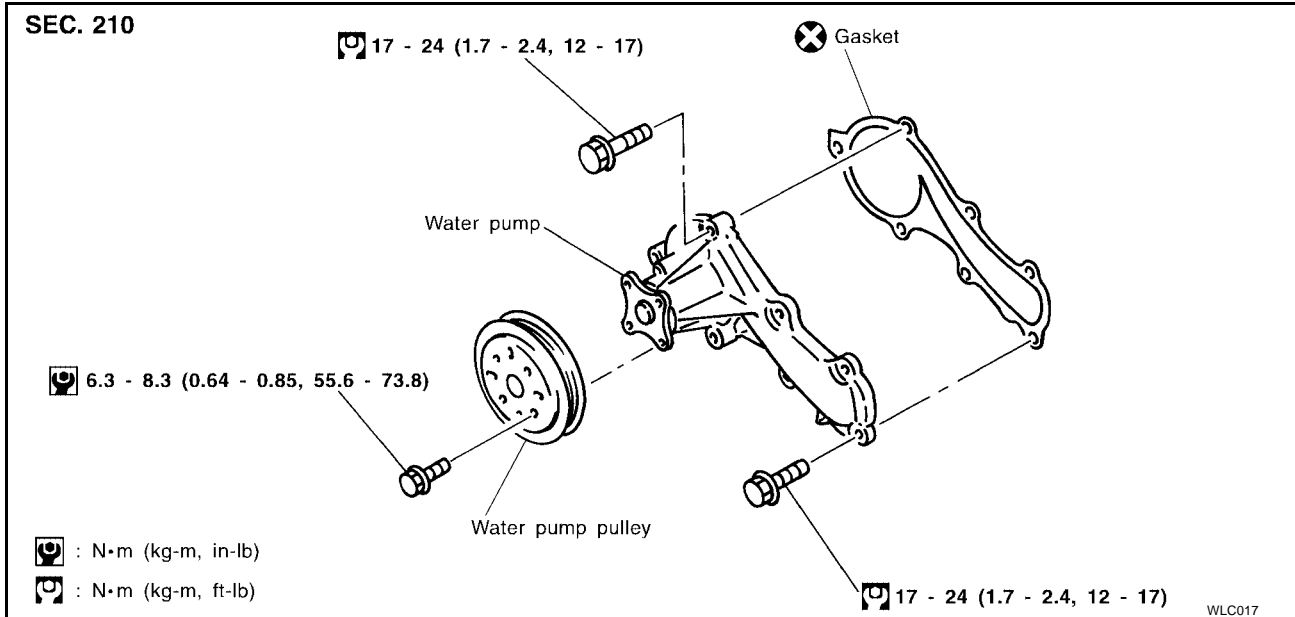

**CAUTION:**

- When removing water pump assembly, be careful not to get coolant on drive belt.
  - Water pump cannot be disassembled and should be replaced as a unit.
  - After installing water pump, check for leaks using radiator cap tester. Refer to [CO-8, "CHECKING COOLING SYSTEM FOR LEAKS"](#).
1. Drain engine coolant.  
Refer to [MA-16, "DRAINING ENGINE COOLANT"](#).

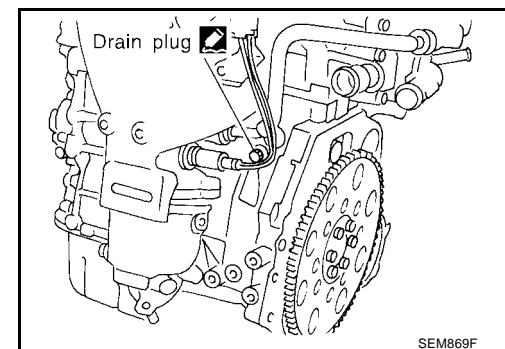
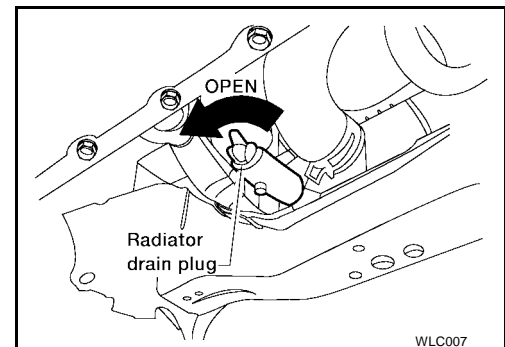

2. Remove front RH wheel.
3. Remove engine side cover.
4. Remove drive belts and idler pulley.
5. Loosen water pump pulley bolts.
6. Remove water pump pulley.

# WATER PUMP

[QG18DE]

7. Remove the water pump bolts.
8. Remove the water pump.
  - Remove liquid gasket from water pump and mating surface of cylinder block using a scraper.
9. Installation is in the reverse order of removal.
  - When applying liquid gasket to mating surface of water pump, use Genuine Anaerobic Liquid Gasket or equivalent. Refer to [GI-46, "RECOMMENDED CHEMICAL PRODUCTS AND SEALANTS"](#).
  - When filling radiator with coolant, refer to [MA-17, "REFILLING ENGINE COOLANT"](#).
  - When installing drive belts, refer to [MA-16, "Checking Drive Belts"](#).

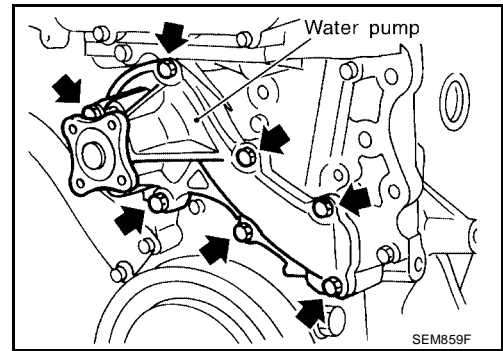

## Inspection

1. Rotate water pump shaft, replace the water pump as necessary.
  - **Check body assembly and vane for rust or corrosion.**
  - **Check for rough operation due to excessive end play.**

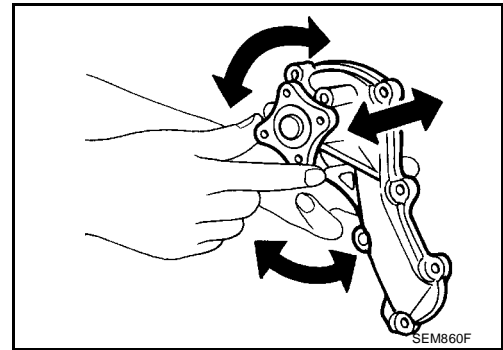

EBS00CH8

A  
CO  
C  
D  
E  
F  
G  
H  
I  
J  
K  
L  
M

## THERMOSTAT AND THERMOSTAT HOUSING

PFP:21200

### Removal and Installation

EBS00CH9

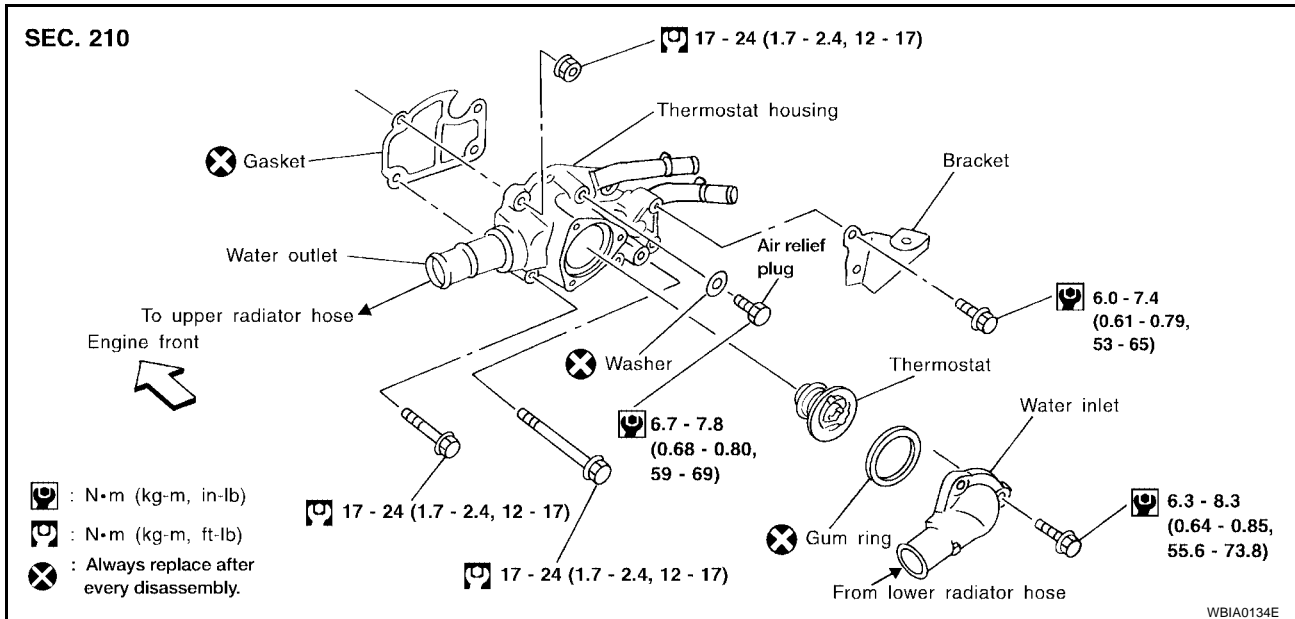

**WARNING:**

Never remove the radiator cap when the engine is hot. Serious burns could occur from high pressure coolant escaping from the radiator.

**CAUTION:**

Perform when the engine is cold.

**CAUTION:**

Be careful not to spill coolant over the engine compartment. Use a rag to absorb any spilled coolant.

### REMOVAL

1. Drain engine coolant. Refer to [MA-16, "DRAINING ENGINE COOLANT"](#) .
2. Disconnect the lower radiator hose.
3. Remove water inlet thermostat housing, then remove the thermostat.

### INSPECTION AFTER REMOVAL

- Place a string so that it is caught in the valve of the thermostat (or water control valve) and suspend it in boiling water. It must be fully immersed in the water.
- The valve opening temperature is the temperature at which the valve plate begins to rise from the top plate causing the thermostat to fall off of the string.
- Continue heating the water and thermostat to check the valve lift (the full-open valve lift distance).

**NOTE:**

The valve lift standard temperature for the thermostat (or water control valve) is the reference value.

- After checking the valve lift, lower the water temperature and check the valve closing temperature.

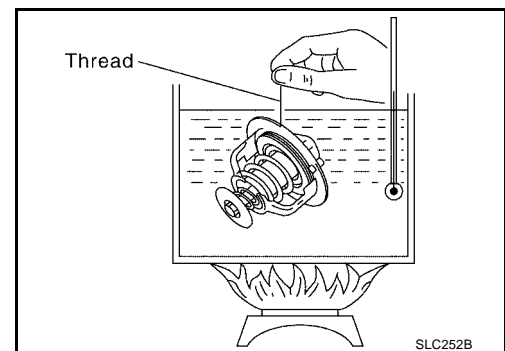

#### Standard Values

Valve opening temperature	76.5°C (170°F)
Valve lift	More than 9 mm/90°C (0.35 in/194°F)
Valve closing temperature	71.5°C (161°F)

## INSTALLATION

1. Installation is in the reverse order of removal, paying attention to the following:

- Before installing the thermostat, make sure the gum ring is properly seated around the thermostat.

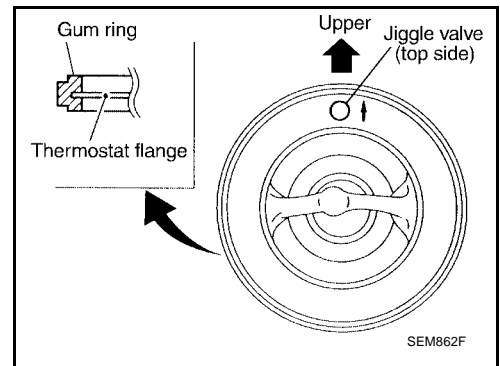

- Install thermostat with jiggle valve or air bleeder at upper side.

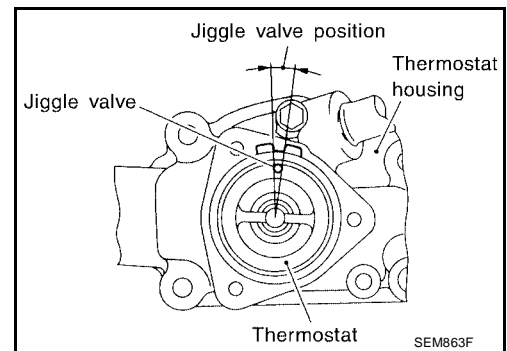

- Refill engine coolant after installation. Run engine for a few minutes, and check for any coolant leaks. Refer to [MA-17, "REFILLING ENGINE COOLANT"](#)

A  
CO  
C  
D  
E  
F  
G  
H  
I  
J  
K  
L  
M

## RADIATOR

### Removal and Installation

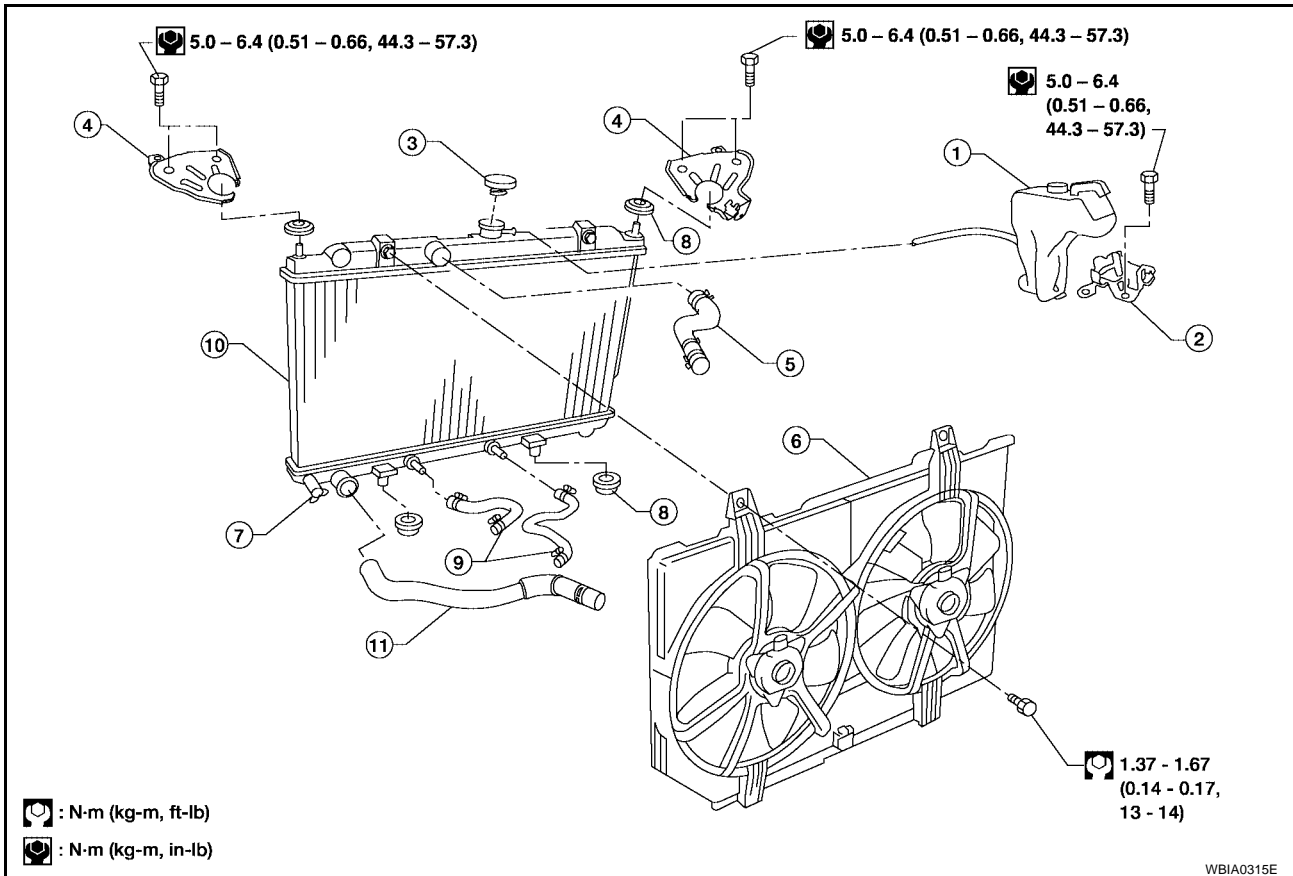

: N-m (kg-m, ft-lb)

: N-m (kg-m, in-lb)

WBIA0315E

- |                        |                           |                                 |
|------------------------|---------------------------|---------------------------------|
| 1. Reservoir tank      | 2. Reservoir tank bracket | 3. Radiator cap                 |
| 4. Mounting bracket    | 5. Upper radiator hose    | 6. Cooling fans                 |
| 7. Radiator drain plug | 8. Mounting rubber        | 9. Oil cooler hose (A/T models) |
| 10. Radiator           | 11. Lower radiator hose   |                                 |

#### WARNING:

Never remove the radiator cap when the engine is hot. Serious burns can occur from high pressure coolant escaping from the radiator. Wrap a thick cloth around the cap. Slowly push down and turn it a quarter of a turn to allow the built-up pressure to escape. Carefully remove the cap by pushing down and turning it the rest of the way.

#### REMOVAL

1. Drain engine coolant. Refer to [MA-16, "DRAINING ENGINE COOLANT"](#).
2. Remove the air duct and air cleaner assembly.
3. Disconnect the A/T oil cooler hoses (if equipped) and install a blind plug in the hoses to prevent A/T oil loss.
4. Disconnect the upper and lower radiator hoses and mounting bracket.
5. Remove the radiator and radiator fan assembly as one unit.

#### CAUTION:

Do not damage or scratch the radiator core when removing.

#### INSTALLATION

- Installation is in the reverse order of removal.

# RADIATOR

[QG18DE]

EBS00CHC

## Disassembly and Assembly

SEC. 214

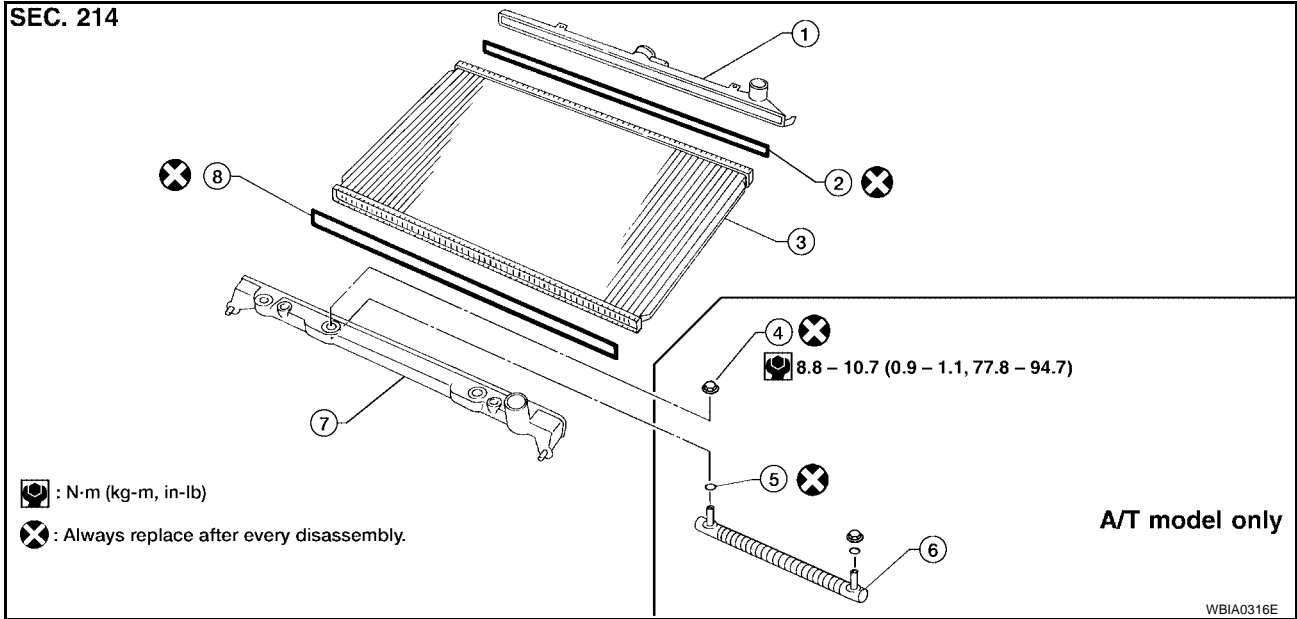

- |                            |                   |               |
|----------------------------|-------------------|---------------|
| 1. Upper tank              | 2. Sealing rubber | 3. Core       |
| 4. Oil cooler securing nut | 5. O-ring         | 6. Oil cooler |
| 7. Lower tank              | 8. Sealing rubber |               |

: N·m (kg·m, in·lb)

: Always replace after every disassembly.

A/T model only

WBIA0316E

### PREPARATION

- Attach the spacer to the tip of the radiator plate pliers A. Spacer specification: 1.5 mm (0.059 in) thick x 18 mm (0.71 in) wide x 8.5 mm (0.335 in) long.
- Make sure that when radiator plate pliers A are closed dimension H'' is approx. 7.6 mm (0.299 in).
- Adjust dimension H'' with the spacer, if necessary.

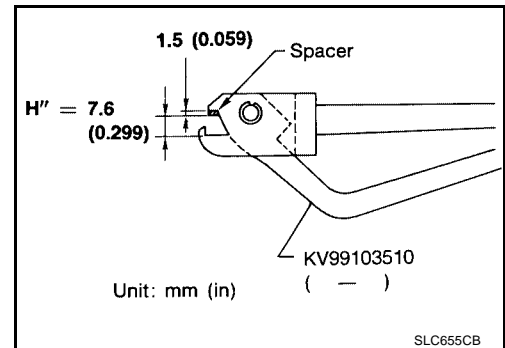

SLC655CB

### DISASSEMBLY

- Remove tank using Tool.

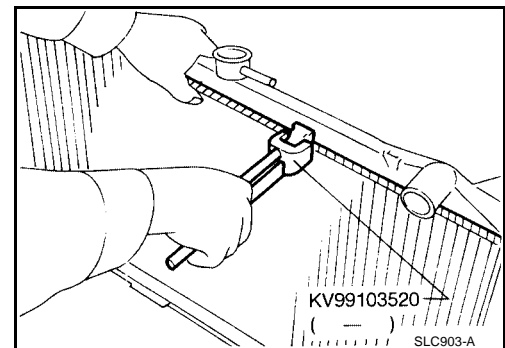

# RADIATOR

[QG18DE]

- Grip the crimped edge and bend it upwards so that Tool slips off.

**CAUTION:**  
Do not bend excessively.

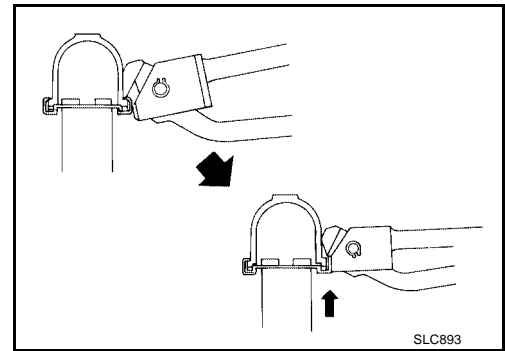

- In areas where Tool cannot be used, use a screwdriver to bend the edge up.

**CAUTION:**  
Be careful not to damage tank.

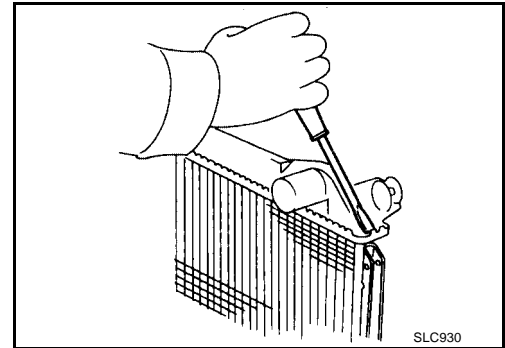

2. Make sure the edge stands straight up.
3. Remove oil cooler from tank (A/T model only).

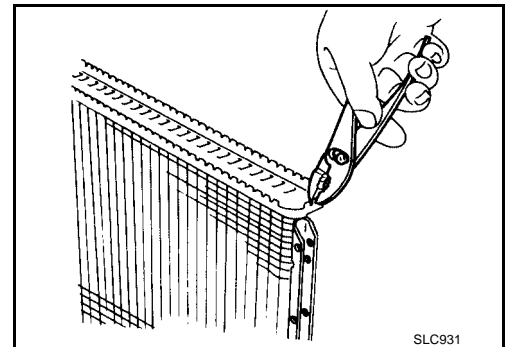

## ASSEMBLY

1. Install oil cooler (A/T model only).

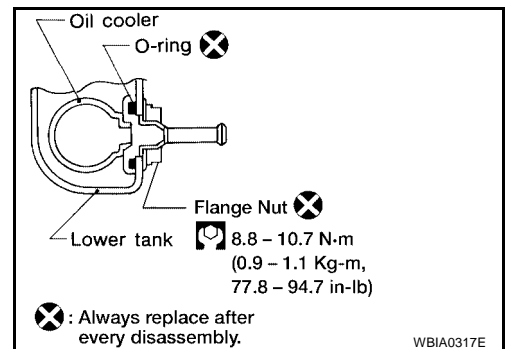



# RADIATOR

[QG18DE]

2. Clean contact portion of tank.

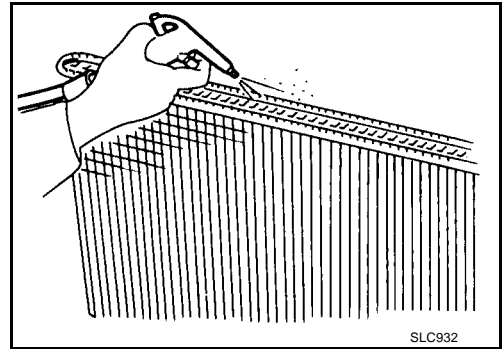

3. Install sealing rubber.

**NOTE:**

Push it in with fingers.

**CAUTION:**

Be careful not to twist sealing rubber.

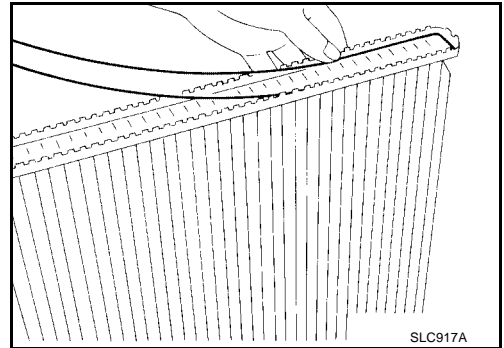

4. Crimp the tank rim in a specified sequence using Tool.

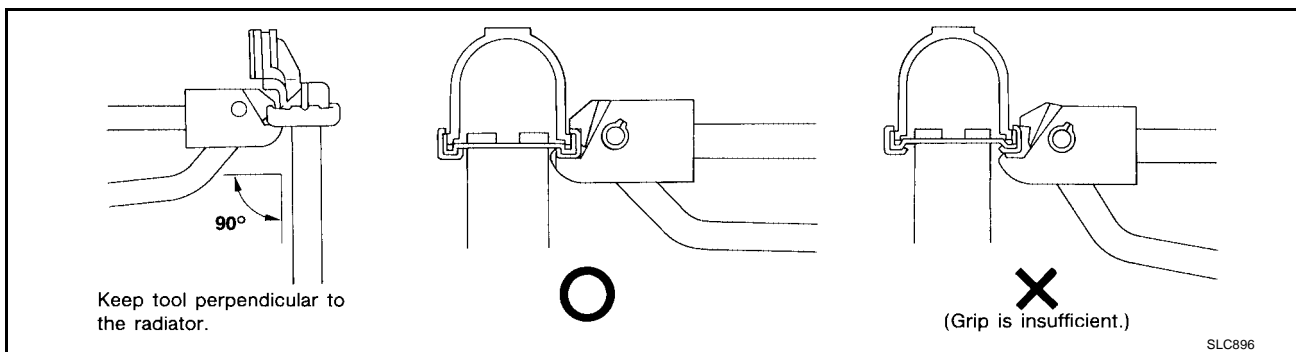
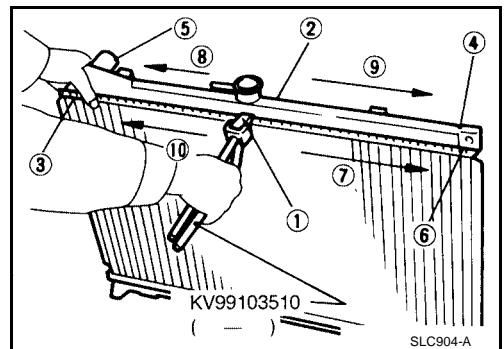

- Use pliers in the locations where the Tool cannot be used.

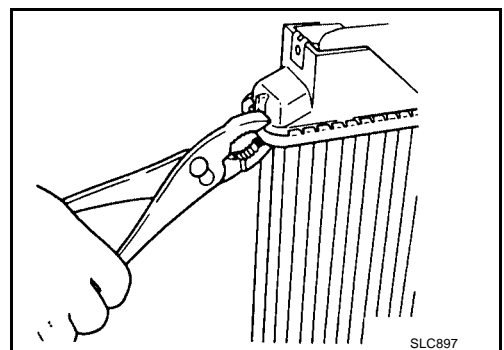

5. Make sure that the tank rim is completely crimped down.

**Standard height "H" : 8.0 - 8.4 mm (0.315 - 0.331 in)**

6. Check for any coolant leakage. Refer to [CO-8, "CHECKING COOLING SYSTEM FOR LEAKS"](#).

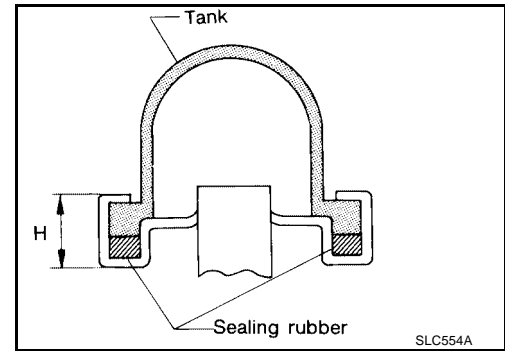

EBS00CHD

## Inspection

1. Apply pressure using Tool.

**Specified pressure value : 157 kPa (1.6 kg/cm<sup>2</sup> , 23 psi)**

**WARNING:**

To prevent the risk of the hose coming undone while under pressure, securely fasten it down with a hose clamp. Attach a hose to the oil cooler as well (A/T model only).

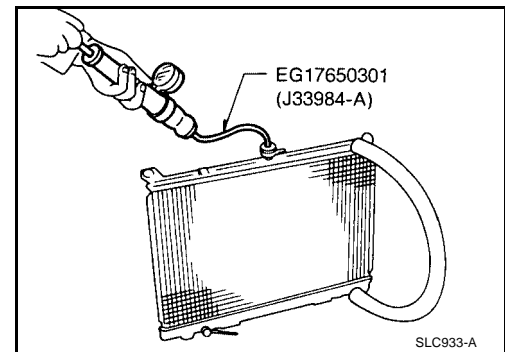

2. Check for leaks in dip tank.

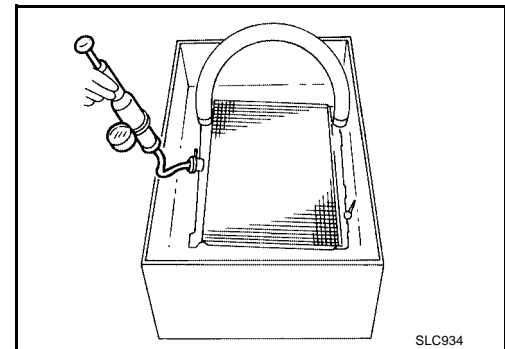

COOLING FAN

Disassembly and Assembly Radiator Cooling Fan

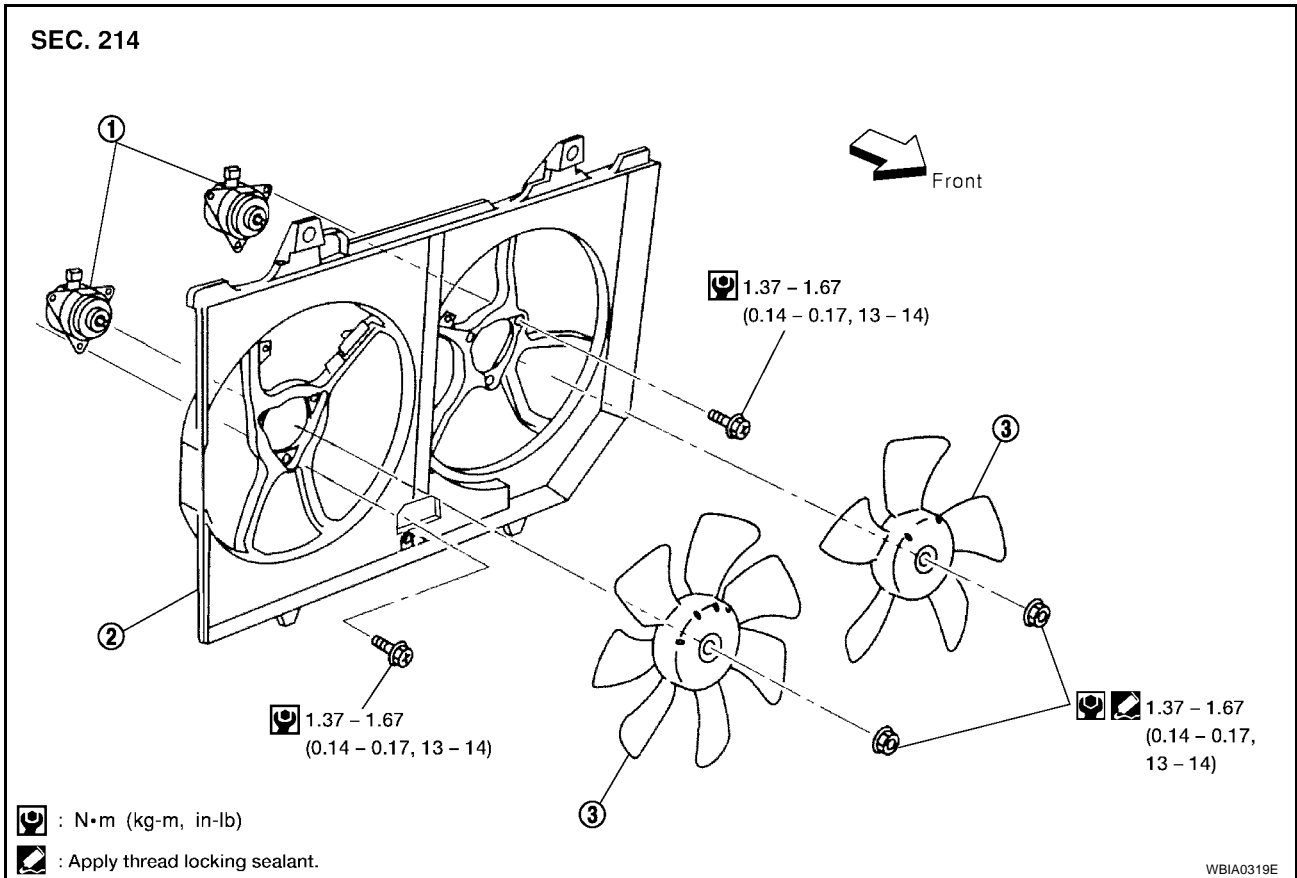

1. Cooling fan motors

2. Cooling fan shroud

3. Cooling fan blades

**DISASSEMBLY**

1. Remove the radiator and cooling fan assembly. Refer to [CO-14, "Removal"](#).
2. Remove the cooling fan shroud assembly from the radiator.
3. Remove the cooling fan blades from the shroud.
4. Remove cooling fan motors from the shroud.

**ASSEMBLY**

- Assembly is in the reverse order of disassembly.

# SERVICE DATA AND SPECIFICATIONS (SDS)

[QG18DE]

## SERVICE DATA AND SPECIFICATIONS (SDS)

PF0:00030

### Capacity

EBS00GJS

Unit: ℓ (US gal, Imp gal)

Coolant capacity with reservoir tank (MAX level)	A/T	6.6 (1 3/4, 1 1/2)
	M/T	6.7 (1 3/4, 1 1/2)

### Thermostat

EBS00CHF

Valve opening temperature	76.5°C (170°F)
Valve lift	More than 9 mm/90°C (0.35 in/194°F)
Valve closing temperature	71.5°C (161°F)

### Radiator

EBS00CHG

Unit: kPa (kg/cm<sup>2</sup>, psi)

Cap relief pressure	Standard	78 - 98 (0.8 - 1.0, 11 - 14)
	Limit	59 (0.6, 9)
Leakage test pressure		157 (1.6, 23)

## PRECAUTIONS

### Precautions For Liquid Gasket REMOVAL OF LIQUID GASKET

- After removing the bolts and nuts, disconnect and remove the sealant using Tool.

**Tool number : KV10111100 (J-37228)**

**CAUTION:**

**Be careful not to damage the mating surfaces.**

- In areas where the cutter is difficult to use, use a plastic hammer to lightly tap the sealant applied area.

**CAUTION:**

**If for some unavoidable reason a tool such as a flat-blade screwdriver is used, be careful not to damage the mating surfaces.**

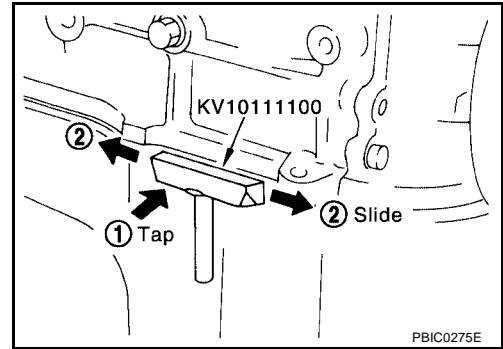

### LIQUID GASKET APPLICATION PROCEDURE

- Using a scraper, remove the old sealant adhering to the application surface and the mating surface.
- Remove the old sealant completely from the groove of the application surface, mounting bolts, and bolt holes.
- Thoroughly clean the application surface and the mating surface to remove adhering moisture, grease and foreign material.
- Attach the sealant tube to the tube presser.

**Use Genuine RTV Silicone Sealant or equivalent. Refer to [GI-46. "RECOMMENDED CHEMICAL PRODUCTS AND SEALANTS"](#) .**

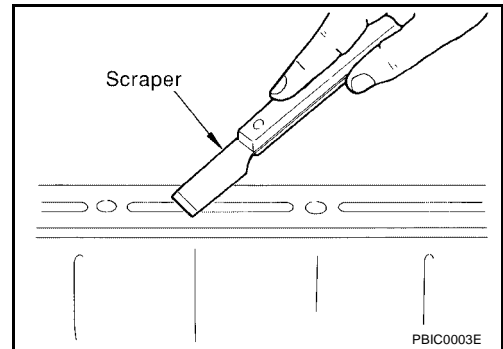

- Apply the sealant without breaks to the specified location with the specified dimensions.
- If there is a groove for the sealant application, apply the sealant to the groove.

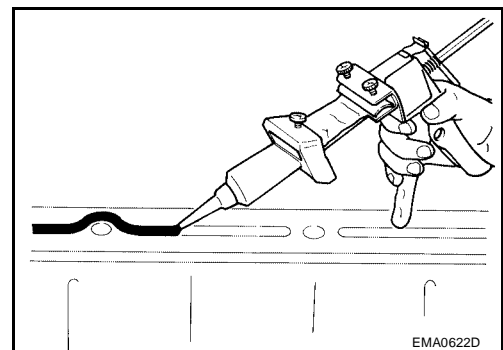

- As for the bolt holes, normally apply the sealant inside the holes. Occasionally, it should be applied outside the holes.
- Within five minutes of sealant application, install the mating component.
- If the sealant protrudes, wipe it off immediately.
- Do not retighten after the installation.
- After 30 minutes or more have passed from the installation, fill the engine with the specified oil and coolant. Refer to [MA-13. "RECOMMENDED FLUIDS AND LUBRICANTS"](#) .

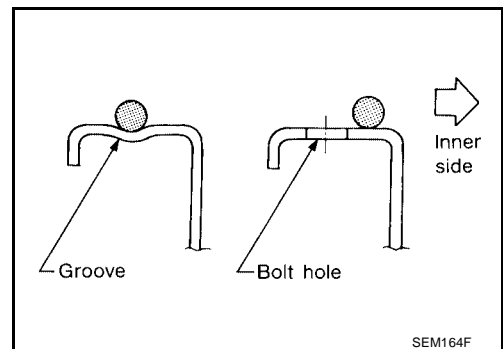

# PREPARATION

[QR25DE]



PFP:00002

EBS00CHI

## PREPARATION

### Special Service Tools

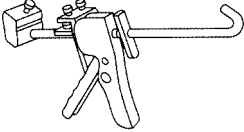
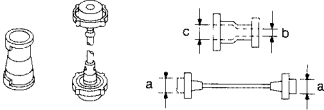
The actual shapes of Kent-Moore tools may differ from those of special tools illustrated here.

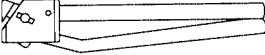
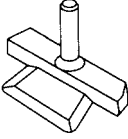
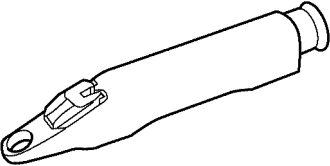
Tool number (Kent-Moore No.) Tool name	Description
WS39930000 ( — ) Tube presser	Pressing the tube of liquid gasket   S-NT052
EG17650301 (J33984-A) Radiator cap tester adapter	Adapting radiator cap tester to radiator filler neck <b>a: 28 (1.10) diameter</b> <b>b: 31.4 (1.236) diameter</b> <b>c: 41.3 (1.626) diameter</b> Unit: mm (in)   S-NT564
KV99103510 ( — ) Radiator plate pliers A	Installing radiator upper and lower tanks   S-NT224
KV99103520 ( — ) Radiator plate pliers B	Removing radiator upper and lower tanks   S-NT225
KV10111100 (J-37228) Seal cutter	Removing sealant   NT046
— (J-23688) Engine coolant refractometer	Checking concentration of ethylene glycol in engine coolant   WBIA0539E

# OVERHEATING CAUSE ANALYSIS

[QR25DE]

PFP:00012

EBS00CHJ

## OVERHEATING CAUSE ANALYSIS

### Troubleshooting Chart

	Symptom		Check items			
Cooling system parts malfunction	Poor heat transfer	Water pump malfunction	Worn or loose drive belt	—	CO	
		Thermostat stuck closed	—			
		Damaged fins	Dust contamination or paper clogging			
			Mechanical damage			
	Reduced air flow	Clogged radiator cooling tube	Excess foreign material (rust, dirt, sand, etc.)	—	C	
		Cooling fan does not operate	Fan blades			
		High resistance to fan rotation				
	Damaged fan blades					
	Damaged radiator shroud	—	—	—	D	
	Improper coolant mixture ratio	—	—	—	E	
	Poor coolant quality	—	—	—	F	
	Insufficient coolant	Coolant leaks	Cooling hose	Loose clamp	—	G
				Cracked hose		
			Water pump	Poor sealing		
				Radiator cap	Loose	
Poor sealing						
Radiator			O-ring for damage, deterioration or improper fitting			
		Cracked radiator tank				
		Cracked radiator core				
Reservoir tank		Cracked reservoir tank		H		
Overflowing reservoir tank	Exhaust gas leaks into cooling system	Cylinder head deterioration	—	I		
		Cylinder head gasket deterioration				

# OVERHEATING CAUSE ANALYSIS

[QR25DE]

	Symptom		Check items		
Except cooling system parts malfunction	—	Overload on engine	Abusive driving	High engine rpm under no load	
				Driving in low gear for extended time	
				Driving at extremely high speed	
			Powertrain system malfunction	—	
			Installed improper size wheels and tires		
			Dragging brakes		
	Blocked or restricted air flow	Blocked or restricted air flow	Blocked bumper	—	Mud, debris, or paper clogging
			Blocked radiator grille	Installed car brassiere	
			Blocked radiator	—	
			Blocked condenser	—	
Installed large fog lamp			—		



# COOLING SYSTEM

[QR25DE]

## COOLING SYSTEM

PFP:21020

### Cooling Circuit

EBS00CHK

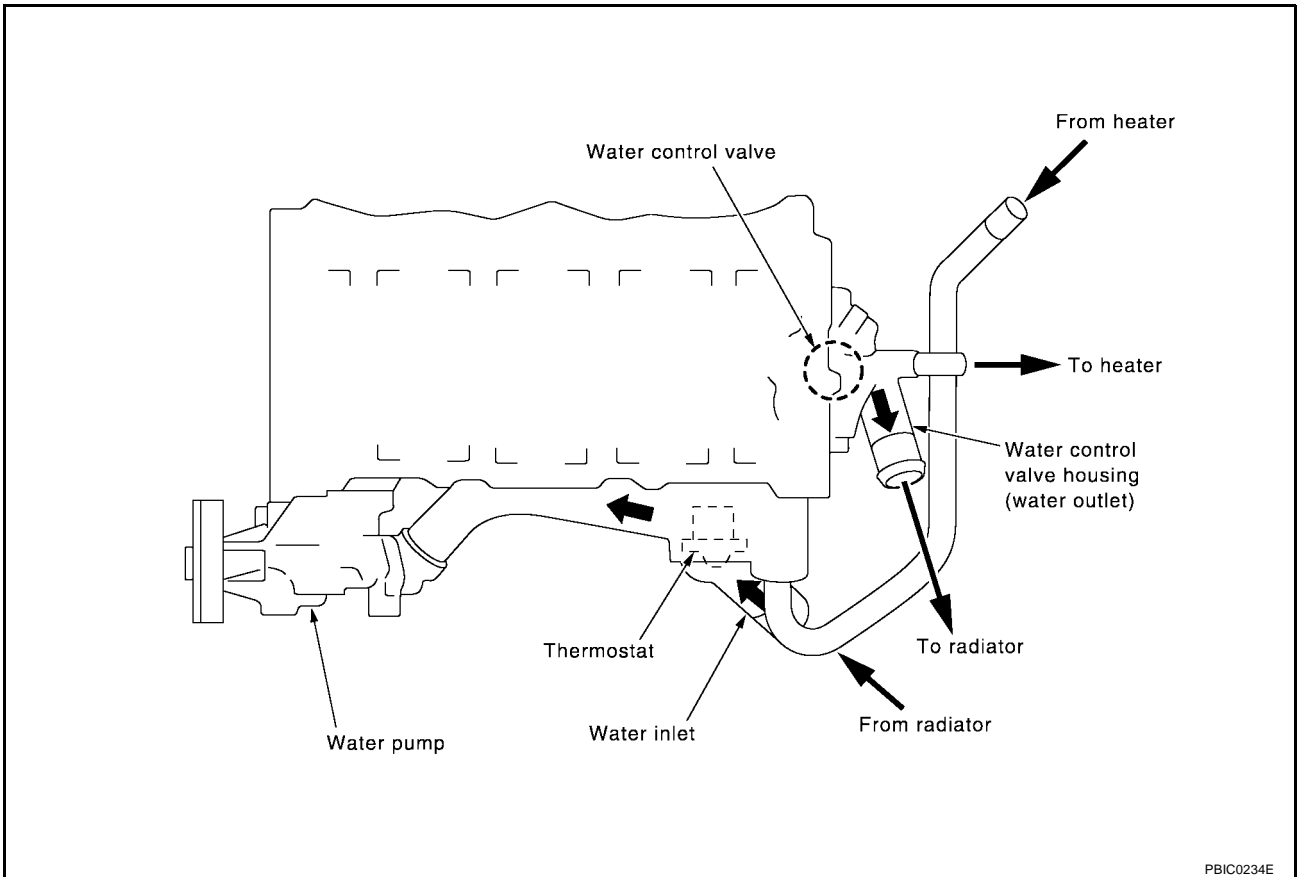

PBIC0234E

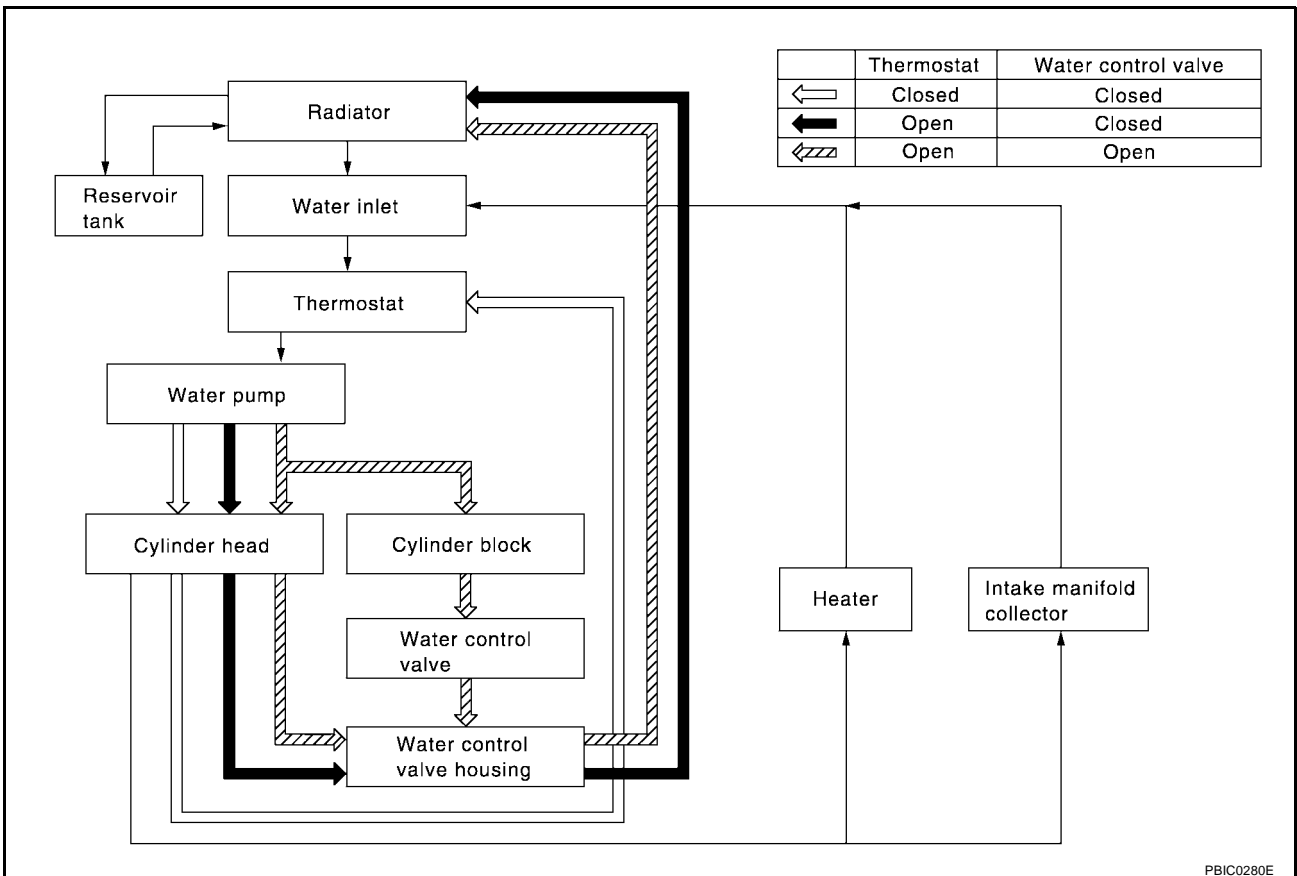

PBIC0280E

## ENGINE COOLANT

### System Check

#### **WARNING:**

Never remove the radiator cap when the engine is hot. Serious burns could occur from high pressure fluid escaping from the radiator.

Wrap a thick cloth around the cap. Slowly push down and turn it a quarter turn to allow built-up pressure to escape. Carefully remove the cap by pushing down and turning it all the way.

### CHECKING COOLING SYSTEM HOSES

Check hoses for the following:

- Improper attachment
- Leaks
- Cracks
- Damage
- Loose connections
- Chafing
- Deterioration

### CHECKING RESERVOIR LEVEL

- Check if the reservoir tank coolant level is within MIN to MAX when the engine is cool.
- Adjust coolant level if it is too much or too little.

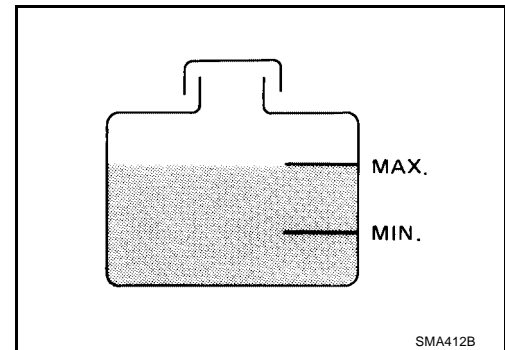

### CHECKING COOLING SYSTEM FOR LEAKS

To check for leakage, apply pressure to the cooling system using Tool.

**Testing pressure : 157 kPa (1.6 kg/cm<sup>2</sup> , 23 psi)**

#### **WARNING:**

Never remove the radiator cap when the engine is hot. Serious burns could occur from high pressure coolant escaping from the radiator.

#### **CAUTION:**

Higher pressure than specified may cause radiator damage.

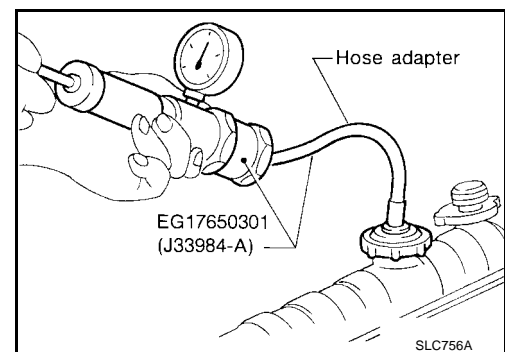

### CHECKING RADIATOR

Check radiator for mud or clogging. If necessary, clean radiator as follows:

- Be careful not to bend or damage the radiator fins.
  - When radiator is cleaned without removal, remove all surrounding parts such as cooling fan, radiator shroud and horns. Then tape the harness and connectors to prevent water from entering.
1. Apply water by hose to the back side of the radiator core vertically downward.
  2. Apply water again to all radiator core surfaces once per minute.
  3. Stop washing when clear water is flowing off the radiator.
  4. Blow air into the back side of radiator core vertically downward.
- Use compressed air lower than 490 kPa (5 kg/cm<sup>2</sup> , 71 psi) and keep distance more than 30 cm (11.8 in).
  - 5. Blow air again into all the radiator core surfaces once per minute until no water sprays out.

6. Check for leaks.

### CHECKING RADIATOR CAP

- Inspect the radiator cap.
  - Replace the cap if the metal plunger cannot be seen around the edge of the black rubber gasket.
  - Replace the cap if deposits of waxy residue or other foreign material are on the black rubber gasket or the metal retainer.

**NOTE:**

Thoroughly wipe out the radiator filler neck to remove any waxy residue or foreign material.

- Pull the negative-pressure valve to open it and check that it closes completely when released.
  - Check that there is no dirt or damage on the valve seat of the radiator cap negative-pressure valve.
  - Check that there are no abnormalities in the opening and closing conditions of the negative-pressure valve.

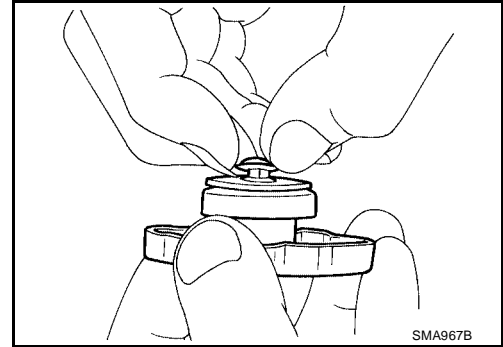

- Check radiator cap relief pressure using Tool.

**Tool number : EG17650301 (J-33984-A)**

**Standard: 78 – 98 kPa (0.8 – 1.0 kg/cm<sup>2</sup> , 11 – 14 psi)**

**Limit: 59 kPa (0.6 kg/cm<sup>2</sup> , 9 psi)**

- When connecting the radiator cap to the tester, apply water or coolant to the cap seal surface.
- Replace the radiator cap if there is an abnormality in the negative-pressure valve, or if the open-valve pressure is outside of the standard values.

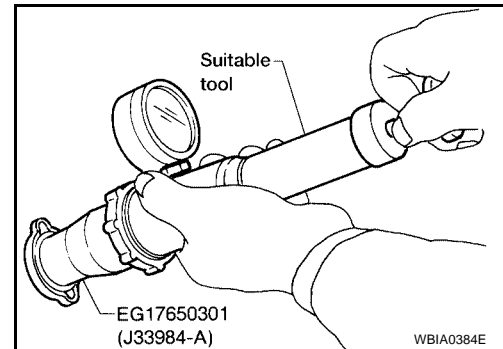

### Refilling Engine Coolant

EBS00EYT

Changing the engine coolant is part of the required maintenance of the engine. Refer to [MA-23, "Changing Engine Coolant"](#) .

## WATER PUMP

### Removal and Installation

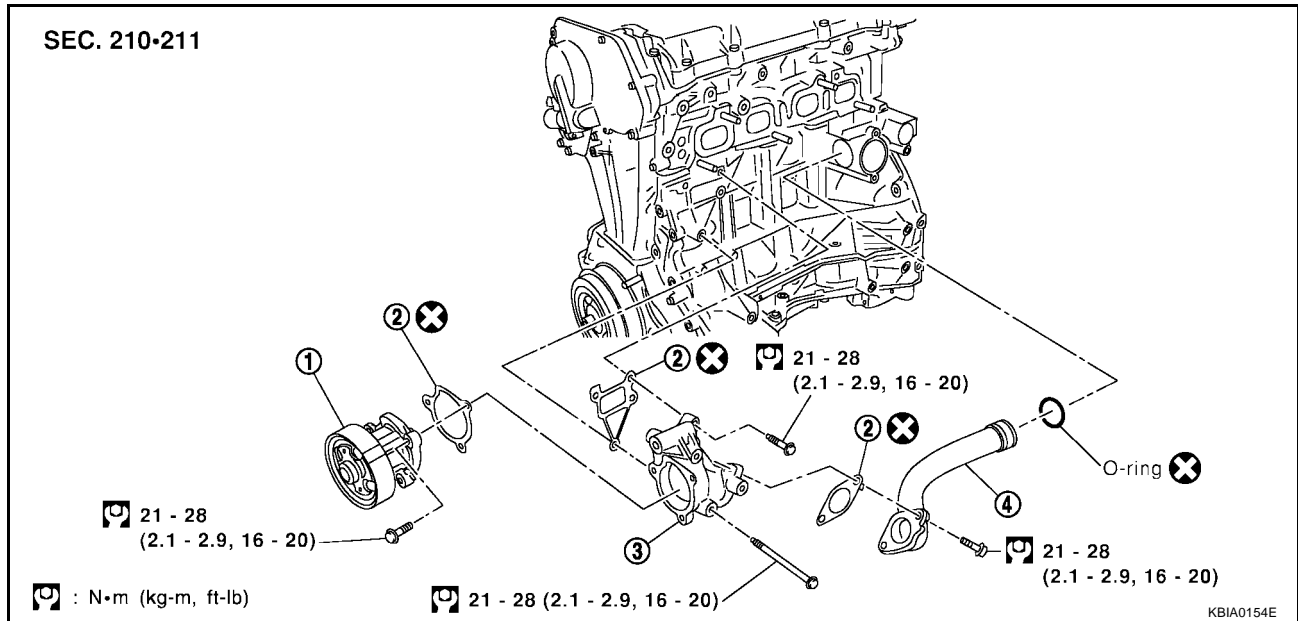

- |               |           |                       |
|---------------|-----------|-----------------------|
| 1. Water pump | 2. Gasket | 3. Water pump housing |
| 4. Water pipe |           |                       |

**WARNING:**

Never remove the radiator cap when the engine is hot. Serious burns could occur from high pressure coolant escaping from the radiator.

### REMOVAL

#### Water Pump

1. Drain the engine coolant. Refer to [MA-23, "DRAINING ENGINE COOLANT"](#) .

**CAUTION:**

**Perform when the engine is cold.**

2. Remove the generator. Refer to [SC-32, "Removal"](#) .
3. Remove the water pump.
  - Coolant will leak from the cylinder block, have a drain pan in position.

**CAUTION:**

- Handle the water pump vane so that it does not contact any other parts.
- The water pump cannot be disassembled and should be replaced as a unit.

4. Remove the water pipe mounting bolts.
5. Remove the water pump housing from the engine block. Use a new gasket for installation.

#### Water Pipe

1. Remove the water pump.
2. Remove the exhaust manifold. Refer to [EX-3, "Removal and Installation"](#) .
3. Remove the water pipe from the thermostat housing.

## INSPECTION AFTER REMOVAL

- Visually check that there is no significant dirt or rust on the water pump body and vane.
- Check that there is no play when rotating the vane shaft, and that it turns smoothly when rotated by hand.
- If necessary, replace the water pump as an assembly.

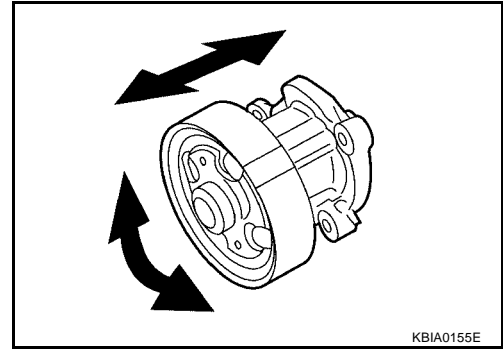

## INSTALLATION

Installation is in the reverse order of removal.

### NOTE:

When inserting the water pipe end into the thermostat housing, apply coolant to the O-ring seal and install immediately.

## INSPECTION AFTER INSTALLATION

After installing the water pump and pipe, check for leaks using the radiator cap tester. Refer to [CO-26, "CHECKING RADIATOR"](#) .

A

CO

C

D

E

F

G

H

I

J

K

L

M

## THERMOSTAT AND THERMOSTAT HOUSING

PFP:21200

### Removal and Installation

EBS00CHO

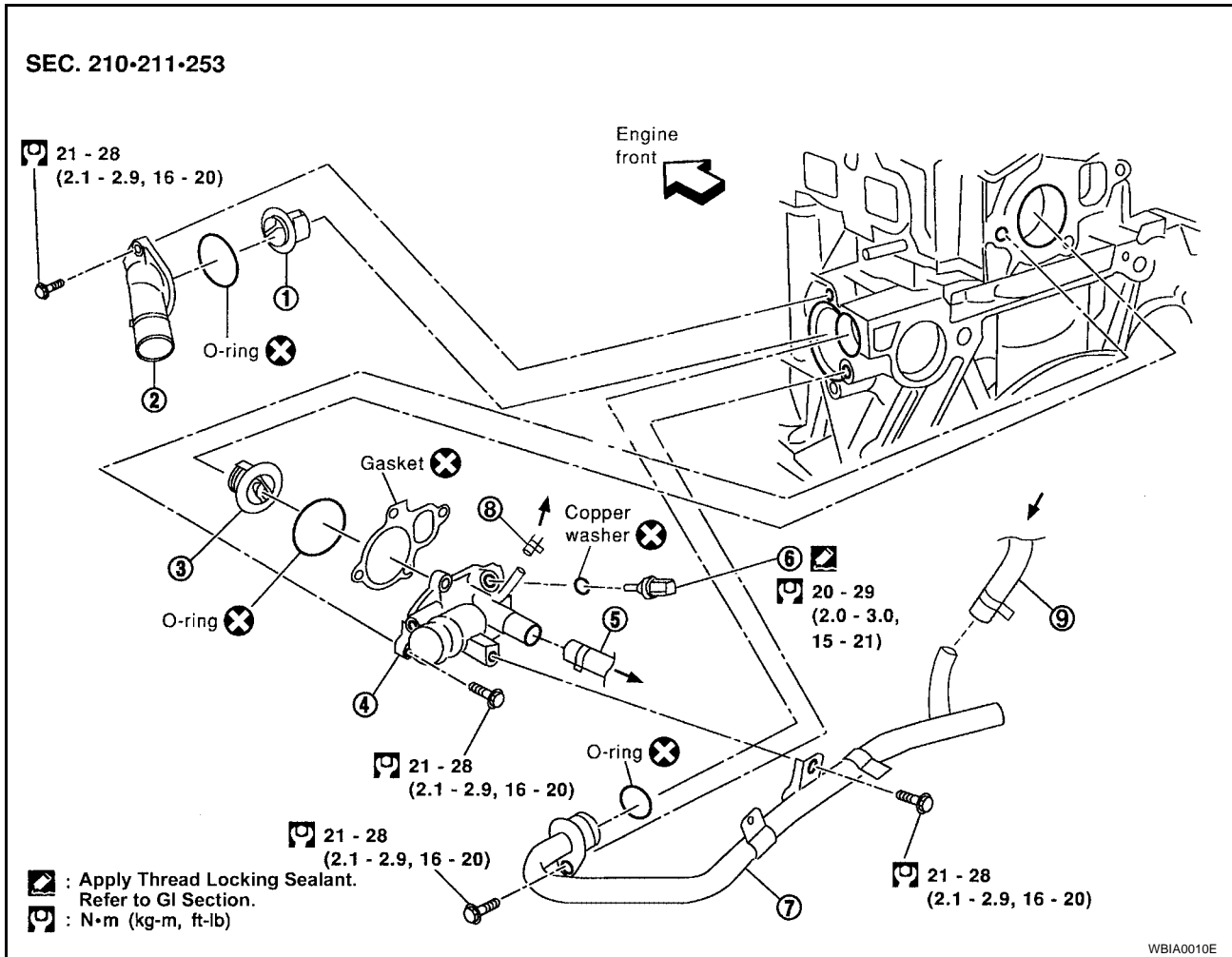

- |                         |                                |                                 |
|-------------------------|--------------------------------|---------------------------------|
| 1. Thermostat           | 2. Water inlet housing         | 3. Water control valve          |
| 4. Water outlet housing | 5. Heater hose                 | 6. Water temperature sensor     |
| 7. Heater pipe          | 8. Throttle body coolant inlet | 9. Throttle body coolant outlet |

#### WARNING:

Never remove the radiator cap when the engine is hot. Serious burns could occur from high pressure coolant escaping from the radiator.

#### CAUTION:

Perform when the engine is cold.

#### CAUTION:

Be careful not to spill coolant over the engine compartment. Use a rag to absorb any spilled coolant.

### REMOVAL

#### Thermostat

1. Drain engine coolant. Refer to [MA-23, "DRAINING ENGINE COOLANT"](#).
2. Remove the lower radiator hose from the water inlet housing.
3. Remove the water inlet housing.
4. Remove the thermostat.

#### Water Control Valve

1. Drain engine coolant. Refer to [MA-23, "DRAINING ENGINE COOLANT"](#).
2. Remove the upper radiator hose, heater pipe, and heater hose.
3. Remove the water outlet housing.

4. Remove the water control valve.

## INSPECTION AFTER REMOVAL

- Place a string so that it is caught in the valve of the thermostat (or water control valve) and suspend it in boiling water. It must be fully immersed in the water.
- The valve opening temperature is the temperature at which the valve plate begins to rise from the top plate causing the thermostat to fall off of the string.
- Continue heating the water and thermostat to check valve lift (the full-open valve lift distance).

**NOTE:**

The valve lift standard temperature for the thermostat (or water control valve) is the reference value.

- After checking the valve lift, lower the water temperature and check the valve closing temperature.

### Standard Values

Component	Thermostat	Water control valve
Valve opening temperature	80.5 - 83.5°C (177 - 182°F)	93.5 - 96.5°C (200 - 206°F)
Valve lift	More than 8 mm/95°C (0.315 in/203°F)	More than 8 mm/108°C (0.315 in/226° F)
Valve closing temperature	77°C (171°F)	90°C (194° F)

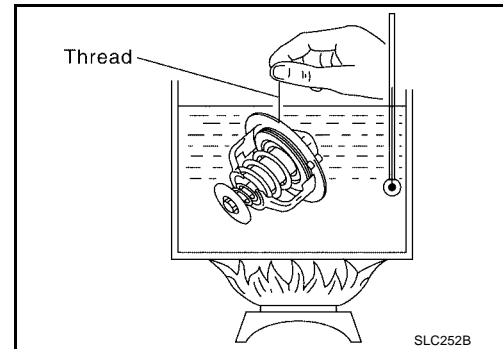

## INSTALLATION

- Installation is in the reverse order of removal.

### Thermostat and Water Control Valve

- Install the thermostat and water control valve with the whole circumference of each flange fitting securely inside the rubber ring. (The example in the figure shown is the thermostat.)

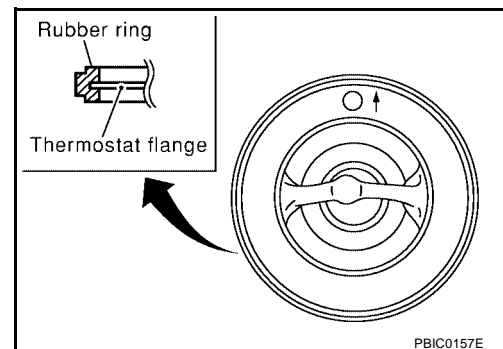

- Install the thermostat with the jiggle valve facing upwards. (The position deviation may be within the range of  $\pm 10^\circ$ .)
- Install the water control valve with the up-mark facing up and the frame center part facing upwards. The position deviation may be within the range of  $\pm 10^\circ$  of vertical.

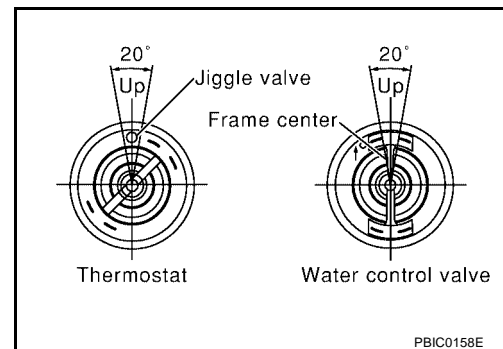

### Heater Pipe

- Apply clean coolant to the heater pipe O-ring, and immediately install the heater pipe into the installation holes.

## RADIATOR

### Removal and Installation

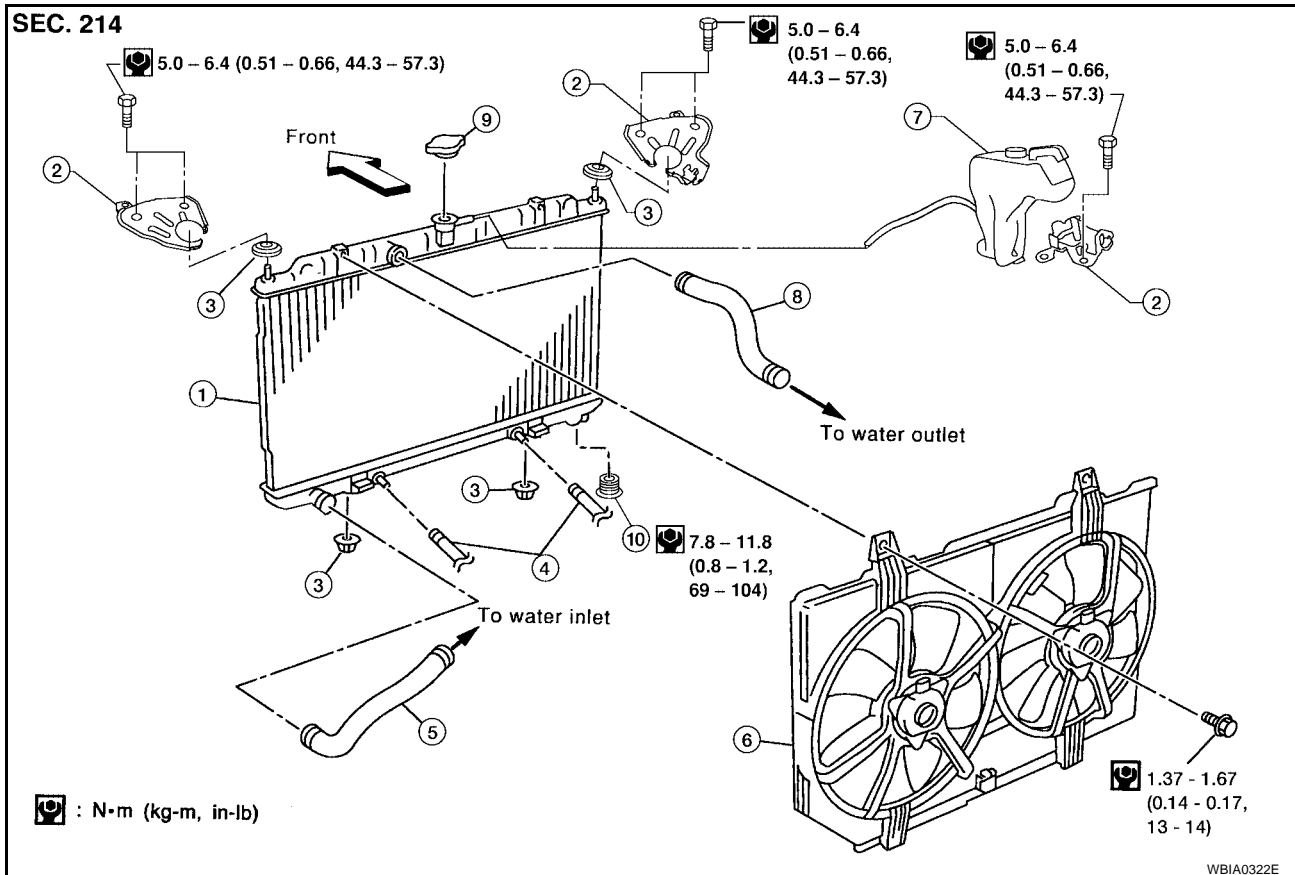

- |                                      |                          |                         |
|--------------------------------------|--------------------------|-------------------------|
| 1. Radiator                          | 2. Bracket               | 3. Mounting rubber      |
| 4. A/T oil cooler hose (if equipped) | 5. Radiator hose (lower) | 6. Cooling fan assembly |
| 7. Reservoir tank                    | 8. Radiator hose (upper) | 9. Radiator cap         |
| 10. Drain plug                       |                          |                         |

### WARNING:

Never remove the radiator cap when the engine is hot. Serious burns could occur from high pressure coolant escaping from the radiator. Wrap a thick cloth around the cap. Slowly push down and turn it a quarter turn to allow built-up pressure to escape. Carefully remove the cap by pushing down and turning it three-quarters around.

### REMOVAL

1. Drain the engine coolant. Refer to [MA-23, "DRAINING ENGINE COOLANT"](#).
2. Remove the air duct with air cleaner assembly. Refer to [EM-106, "Removal and Installation"](#).
3. Disconnect A/T oil cooler hoses (if equipped).
  - Install a blind plug to avoid leakage of A/T oil.
4. Disconnect the radiator upper hose, lower hose, and mounting bracket.
5. Remove the radiator and cooling fan assembly

### CAUTION:

- Do not damage or scratch radiator core when removing.

### INSTALLATION

Installation is in the reverse order of removal.

- After installation, run the engine until it reaches full operating temperature and check for any cooling system leaks. Repair any leaks as necessary.



# RADIATOR

[QR25DE]

EBS00CHO

## Disassembly and Assembly

SEC. 214

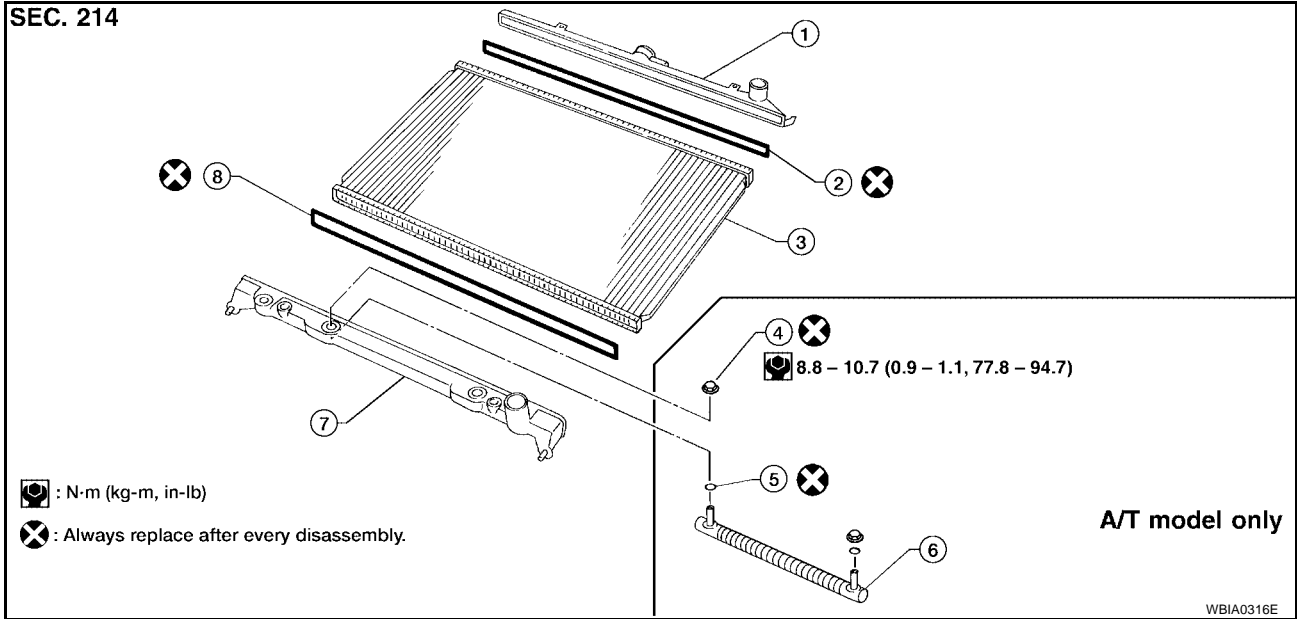

- |                            |                   |               |
|----------------------------|-------------------|---------------|
| 1. Upper tank              | 2. Sealing rubber | 3. Core       |
| 4. Oil cooler securing nut | 5. O-ring         | 6. Oil cooler |
| 7. Lower tank              | 8. Sealing rubber |               |

: N·m (kg·m, in·lb)

: Always replace after every disassembly.

A/T model only

WBIA0316E

### PREPARATION

1. Attach the spacer to the tip of the radiator plate pliers A. Spacer specification: 1.5 mm (0.059 in) thick x 18 mm (0.71 in) wide x 8.5 mm (0.335 in) long.
2. Make sure that when radiator plate pliers A are closed dimension H'' is approx. 7.6 mm (0.299 in).
3. Adjust dimension H'' with the spacer, if necessary.

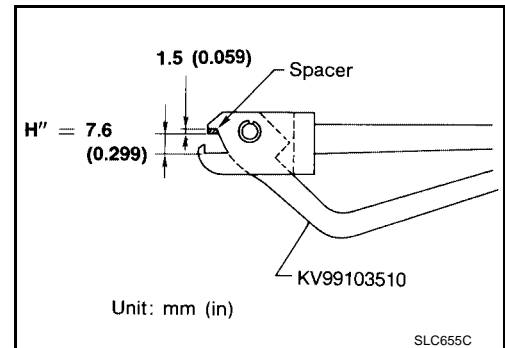

SLC655C

### DISASSEMBLY

1. Remove tank using Tool.

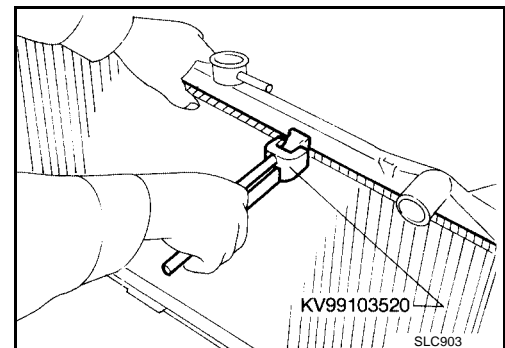

SLC903

# RADIATOR

[QR25DE]

- Grip the crimped edge and bend it upwards so that the Tool slips off.

**CAUTION:**

**Do not bend excessively.**

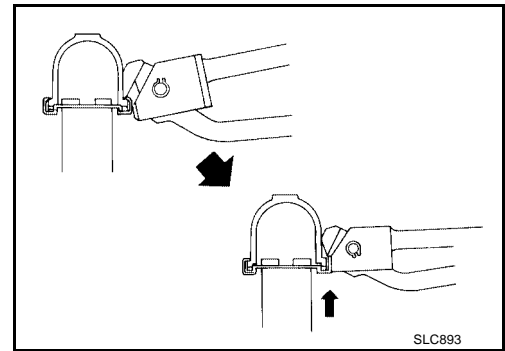

- In areas where Tool cannot be used, use a screwdriver to bend the edge up.

**CAUTION:**

**Be careful not to damage tank.**

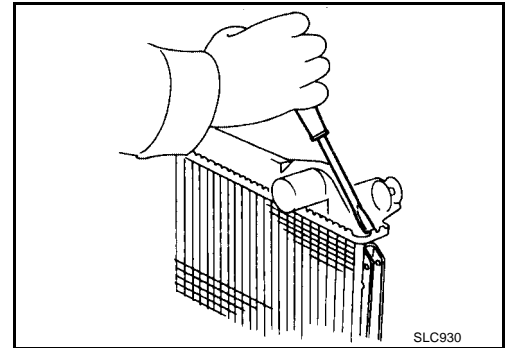

2. Make sure the edge stands straight up.
3. Remove oil cooler from tank (A/T model only).

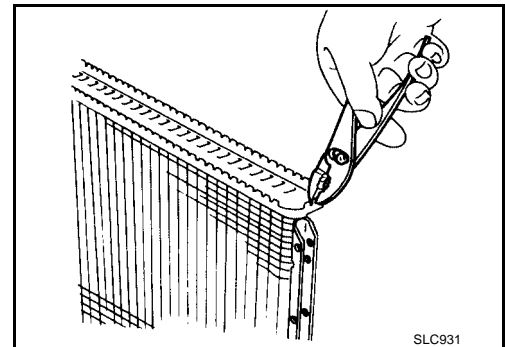

## ASSEMBLY

1. Install oil cooler (A/T model only).

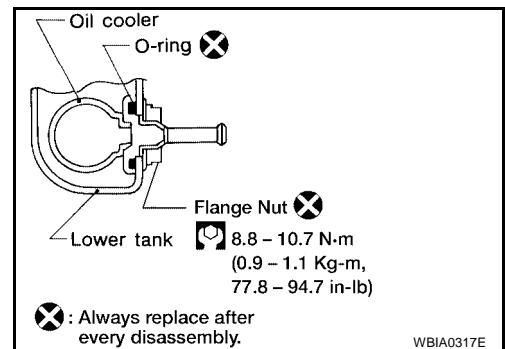

# RADIATOR

[QR25DE]

2. Clean contact portion of tank.

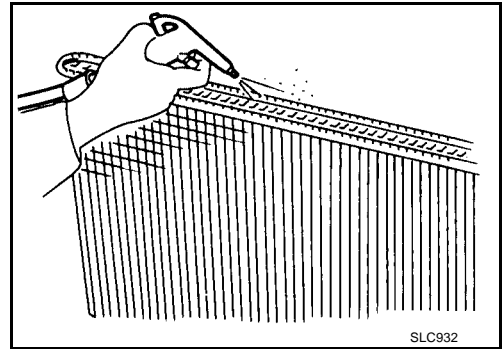

3. Install sealing rubber.

**NOTE:**

Push it in with fingers.

**CAUTION:**

Be careful not to twist sealing rubber.

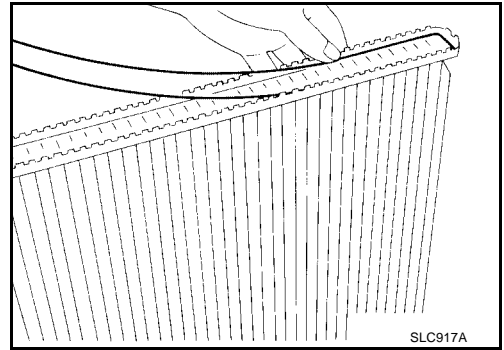

4. Crimp tank in specified sequence using Tool.

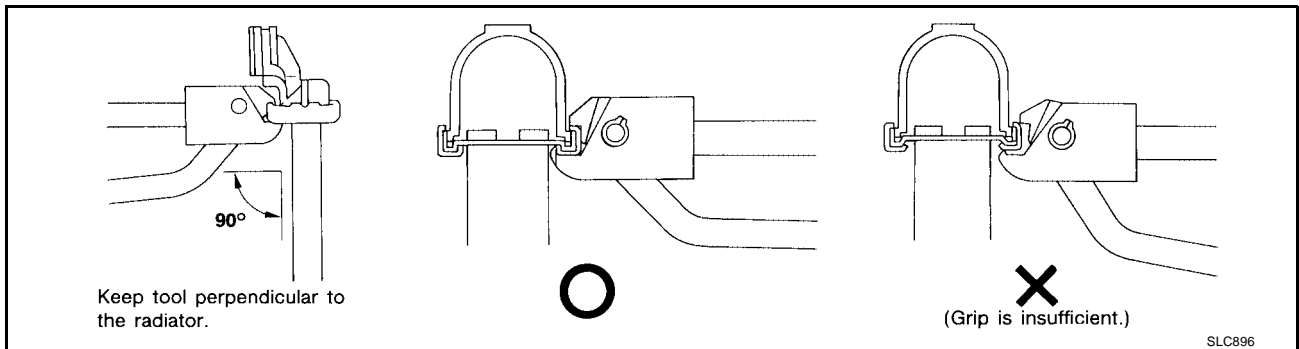
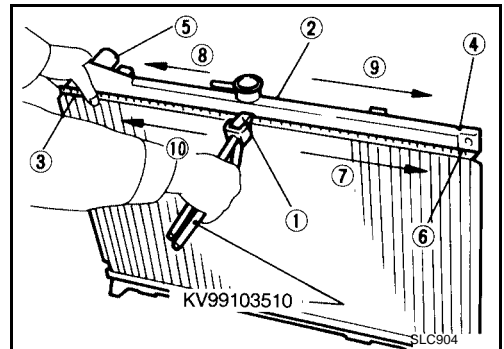

- Use pliers in the locations where Tool cannot be used.

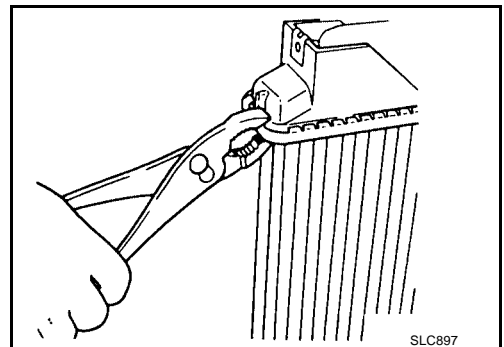

A  
CO  
C  
D  
E  
F  
G  
H  
I  
J  
K  
L  
M

# RADIATOR

[QR25DE]

5. Make sure that the rim is completely crimped down.

**Standard height "H" : 8.0 - 8.4 mm (0.315 - 0.331 in)**

6. Confirm that there is no leakage.

- Refer to [CO-26, "CHECKING COOLING SYSTEM FOR LEAKS"](#).

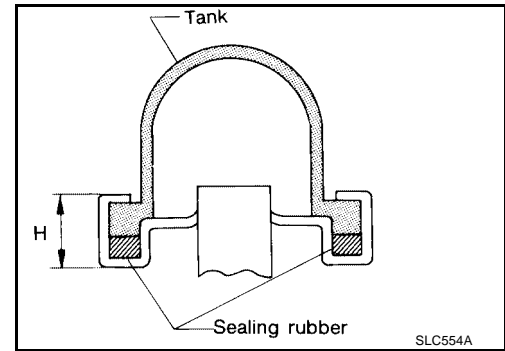

EBS00CHR

## Inspection

1. Apply pressure using Tool.

**Specified pressure value : 157 kPa (1.6 kg/cm<sup>2</sup> , 23 psi)**

### **WARNING:**

To prevent the risk of the hose coming undone while under pressure, securely fasten it down with a hose clamp. Attach a hose to the oil cooler as well (A/T model only).

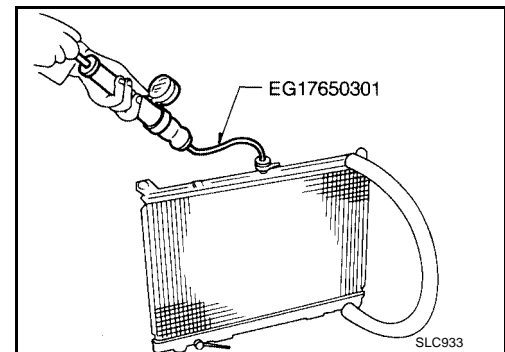

2. Check for leaks in dip tank.

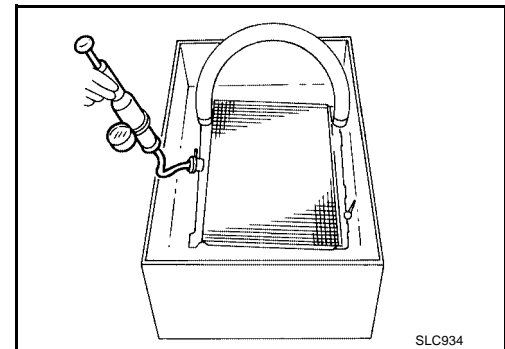

COOLING FAN

Disassembly and Assembly

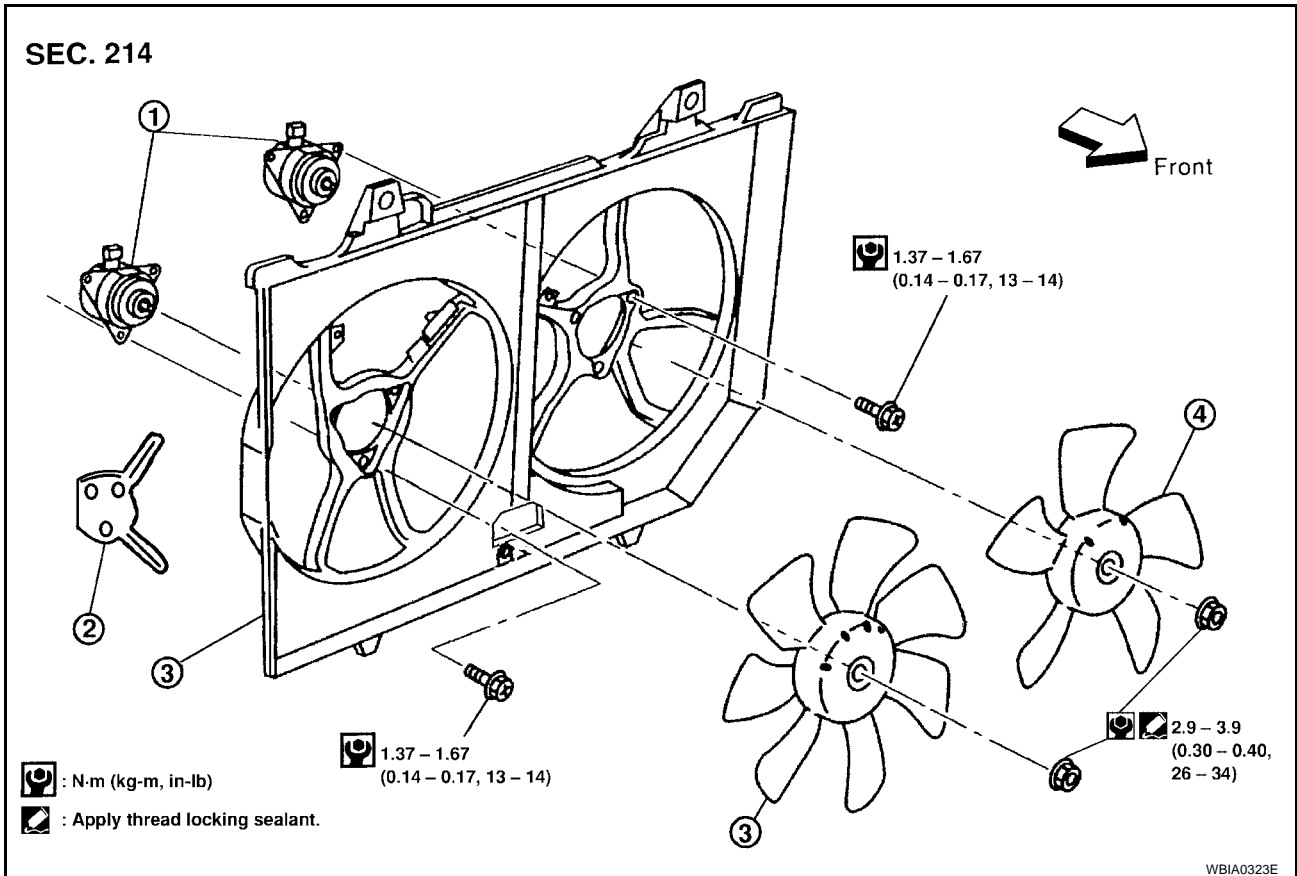

- 1. Cooling fan motor
- 2. Insulator
- 3. Cooling fan shroud
- 4. Cooling fan blade

**DISASSEMBLY**

1. Remove the radiator and cooling fan assembly. Refer to [CO-32, "REMOVAL"](#).
2. Remove the cooling fan shroud from the radiator.
3. Remove the cooling fan blades from the cooling fan motors.
4. Remove the insulator.
5. Remove the cooling fan motors from the fan shroud.

**ASSEMBLY**

- Assembly is in the reverse order of disassembly.

# SERVICE DATA AND SPECIFICATIONS (SDS)

[QR25DE]

## SERVICE DATA AND SPECIFICATIONS (SDS)

PFP:00030

### Capacity

EBS00CHT

Unit: ℓ (US gal, Imp gal)

Coolant capacity with reservoir tank (MAX level)	A/T	6.7 (1 3/4, 1 1/2)
	M/T	6.8 (1 3/4, 1 1/2)

### Thermostat

EBS00CHU

Valve opening temperature	80.5 - 83.5°C (177 - 182°F)
Valve lift	More than 8 mm/95°C (0.315 in/203°F)
Valve closing temperature	77°C (171°F)

### Water Control Valve

EBS00CHV

Valve opening temperature	93.5 - 96.5°C (200 - 206°F)
Valve lift	More than 8 mm/108°C (0.315 in/226°F)
Valve closing temperature	90°C (194°F)

### Radiator

EBS00CHW

Unit: kPa (kg/cm<sup>2</sup>, psi)

Cap relief pressure	Standard	78- 98 (0.8 -1.0, 11-14)
	Limit	59 (0.6, 9)
Leakage test pressure		157 (1.6, 23)