

SECTION **RSU**
 REAR SUSPENSION

A
B
C
D

RSU

CONTENTS

PRECAUTIONS	2	Disassembly	10	F
Precautions	2	Inspection	10	
PREPARATION	3	SHOCK ABSORBER ASSEMBLY	10	
Commercial Service Tools	3	UPPER RUBBER SEAT AND BUSHING	10	G
NOISE, VIBRATION, AND HARSHNESS (NVH)		COIL SPRING	10	
TROUBLESHOOTING	4	Assembly	10	
NVH Troubleshooting Chart	4	TORSION BEAM, LATERAL LINK AND CONTROL		H
REAR SUSPENSION ASSEMBLY	5	ROD	11	
Components	5	Disassembly	11	
On-Vehicle Service	6	Inspection	11	
Rear Wheel Alignment	6	Rubber Bushing Replacement	11	I
PRELIMINARY INSPECTION	6	TRAILING ARM	11	
CAMBER	7	LATERAL LINK	11	
TOE-IN	7	CONTROL ROD	11	J
REMOVAL AND INSTALLATION	8	Assembly	12	
Removal and Installation	8	SERVICE DATA AND SPECIFICATIONS (SDS)	13	
REMOVAL	8	General Specifications (Rear)	13	K
INSTALLATION	8	Rear Wheel Alignment (Unladen*)	13	
COIL SPRING AND SHOCK ABSORBER	10	Wheelarch Height (Unladen*)	13	L
Removal and Installation	10			M

PRECAUTIONS

PRECAUTIONS

PFP:00001

Precautions

EES0001T

- When installing each rubber part, final tightening must be carried out under unladen condition* with tires on ground. Oil will shorten the life of rubber bushings. Be sure to wipe off any spilled oil.
*: Fuel, radiator coolant and engine oil full. Spare tire, jack, hand tools and mats in designated positions.
- Use flare nut wrench when removing or installing brake tubes.
- After installing removed suspension parts, check wheel alignment.
- Do not jack up at the trailing arm and lateral link.
- Always torque brake lines when installing.
- Lock nuts are un reusable parts; always use new ones. When replacing, do not wipe the oil off of the new lock nut before tightening.

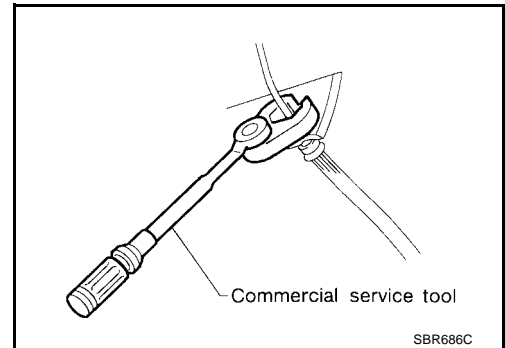

PREPARATION

PREPARATION

PFP:00002

Commercial Service Tools

EES000IU

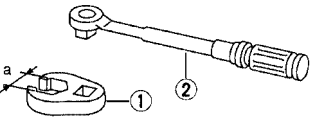
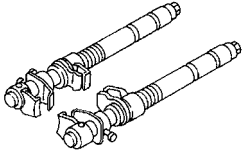
Tool name	Description
<p>Equivalent to GG94310000 1 Flare nut crowfoot 2 Torque wrench</p>  <p>S-NT360</p>	<p>Removing and installing brake piping a: 10 mm (0.39 in)</p>
<p>Spring compressor</p>  <p>NT717</p>	<p>Removing and installing coil spring</p>

A
B
C
D
RSU
F
G
H
I
J
K
L
M

NOISE, VIBRATION, AND HARSHNESS (NVH) TROUBLESHOOTING

NOISE, VIBRATION, AND HARSHNESS (NVH) TROUBLESHOOTING

PFP:00003

NVH Troubleshooting Chart

EES000IV

Use the following chart to help you find the cause of the symptom. If necessary, repair or replace these parts.

Symptom		Possible Cause and SUSPECTED PARTS															Reference page				
		Improper installation, looseness	Shock absorber deformation, damage or deflection	Bushing or mounting deterioration	Parts interference	Spring fatigue	Suspension looseness	Incorrect wheel alignment	Out-of-round	Imbalance	Incorrect air pressure	Uneven tire wear	Deformation or damage	Non-uniformity	Incorrect tire size	AXLE	SUSPENSION	TIRES	ROAD WHEEL	BRAKES	
SUSPENSION	Noise	x	x	x	x	x	x														Refer to RSU-5
	Shake	x	x	x	x		x									x		x	x	x	Refer to RSU-5
	Vibration	x	x	x	x	x										x		x			Refer to RSU-10 , RSU-11
	Shimmy	x	x	x	x			x								x		x	x	x	—
	Judder	x	x	x												x		x	x	x	Refer to RSU-13
	Poor quality ride or handling	x	x	x	x	x		x								x		x	x		Refer to RSU-5 , RSU-6
TIRES	Noise	x							x	x	x	x	x		x	x			x	x	Refer to RSU-6
	Shake	x							x	x	x	x		x	x	x			x	x	Refer to WT-4
	Vibration										x			x	x	x					Refer to WT-6
	Shimmy	x							x	x	x	x	x	x	x	x	x			x	—
	Judder	x							x	x	x	x	x	x	x	x	x			x	Refer to RSU-13
	Poor quality ride or handling	x							x	x	x	x	x		x	x	x			x	Refer to RAX-4
ROAD WHEEL	Noise	x							x	x		x			x	x	x	x	x	x	Refer to SUSPENSION in this chart.
	Shake	x							x	x		x			x	x	x	x		x	Refer to TIRES in this chart.
	Shimmy, Judder	x							x	x		x			x	x	x			x	Refer to ROAD WHEEL in this chart.
	Poor quality ride or handling	x							x	x		x			x	x	x			x	Refer to BR-5

x: Applicable

REAR SUSPENSION ASSEMBLY

REAR SUSPENSION ASSEMBLY

PF:55020

Components

EES000W

SEC.431

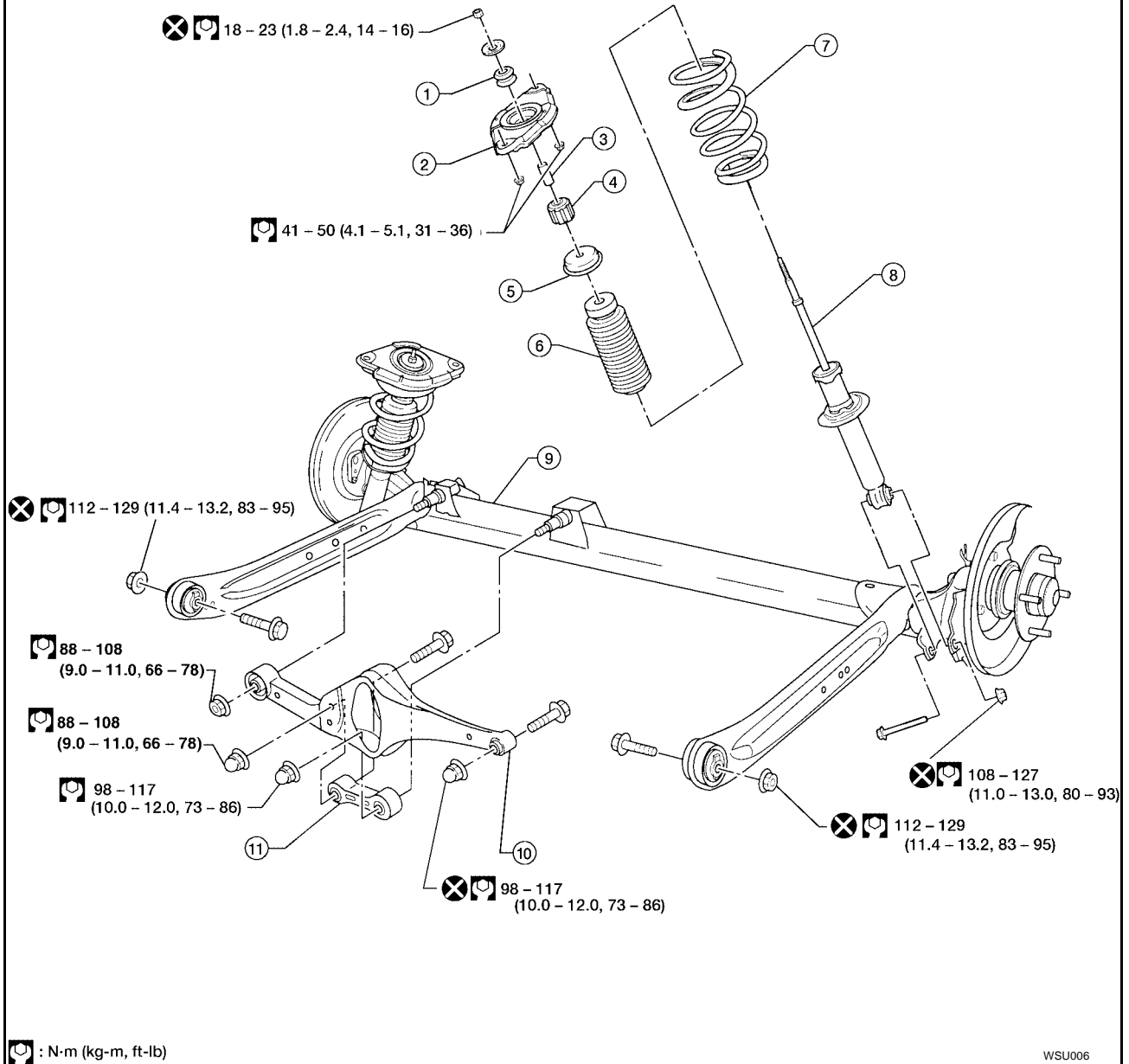

- | | | |
|--------------------------|------------------------------------|------------------|
| 1. Bushing | 2. Shock absorber mounting bracket | 3. Distance tube |
| 4. Distance tube bushing | 5. Bound bumper cover | 6. Bound bumper |
| 7. Coil spring | 8. Shock absorber | 9. Torsion beam |
| 10. Lateral link | 11. Control rod | |

A
B
C
D
RSU
F
G
H
I
J
K
L
M

REAR SUSPENSION ASSEMBLY

EES0001X

On-Vehicle Service

Check axle and suspension parts for excessive play, wear or damage.

- Shake each rear wheel to check for excessive play.
- Retighten all nuts and bolts to the specified torque.

Tightening torque : Refer to [RSU-5, "Components"](#) .

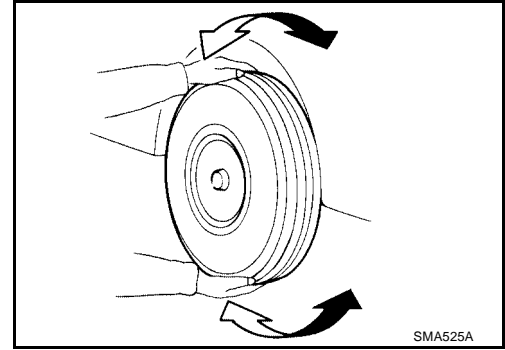

- Check shock absorber for oil leakage or other damage.
- Check wheelarch height. Refer to [RSU-13, "Wheelarch Height \(Unladen*\)"](#) .

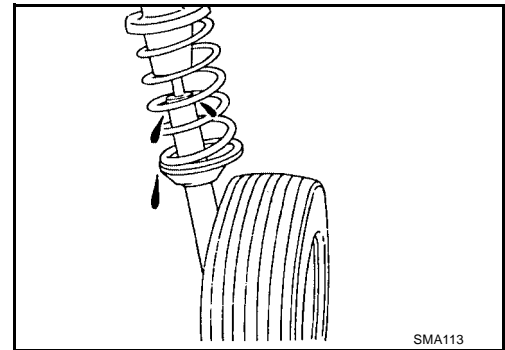

Rear Wheel Alignment

EES0001Y

Before checking rear wheel alignment, be sure to make a preliminary inspection (Unladen*).

*: Fuel, radiator coolant and engine oil full. Spare tire, jack, hand tools and mats in designated positions.

PRELIMINARY INSPECTION

1. Check tires for wear and improper inflation.
2. Check wheels for deformation, cracks and other damage. If deformed, remove wheel and check wheel runout.
 - a. Remove tire from wheel and mount wheel on a tire balance machine.
 - b. Set dial indicator as shown in the illustration.

Wheel runout (Dial indicator value) : Refer to [WT-6, "Road Wheel"](#) .

3. Check front wheel bearings for looseness.
4. Check front suspension for looseness.
5. Check steering linkage for looseness.
6. Check that front shock absorbers work properly.
7. Check vehicle wheelarch height (unladen*). Refer to [RSU-13, "Wheelarch Height \(Unladen*\)"](#) .

- *: Fuel, radiator coolant and engine oil full. Spare tire, jack, hand tools and mats in designated positions.

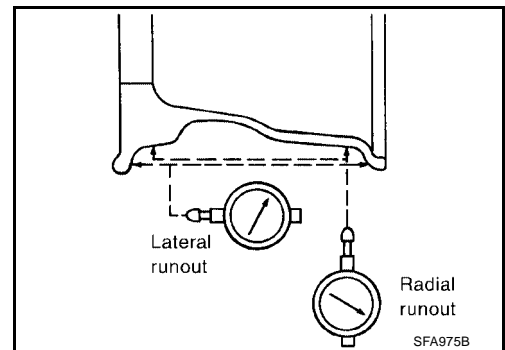

REAR SUSPENSION ASSEMBLY

CAMBER

Camber is preset at factory and cannot be adjusted.

Camber : Refer to [RSU-13, "Rear Wheel Alignment \(Unladen*\)"](#) .

1. Measure camber of both right-hand and left-hand wheels with a suitable alignment gauge.
2. If the camber is not within specification, inspect and replace any damaged or worn rear suspension parts.

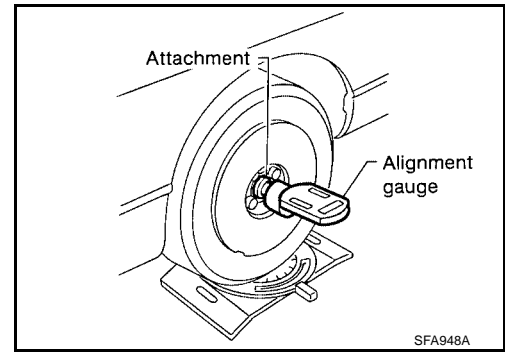

TOE-IN

Toe-in is preset at factory and cannot be adjusted.

Measure toe-in using following procedure. If out of specification, inspect and replace any damaged or worn rear suspension parts.

WARNING:

- Always perform the following procedure on a flat surface.
 - Make sure that no person is in front of the vehicle before pushing it.
1. Bounce rear of vehicle up and down to stabilize the posture.
 2. Push the vehicle straight ahead about 5 m (16 ft).

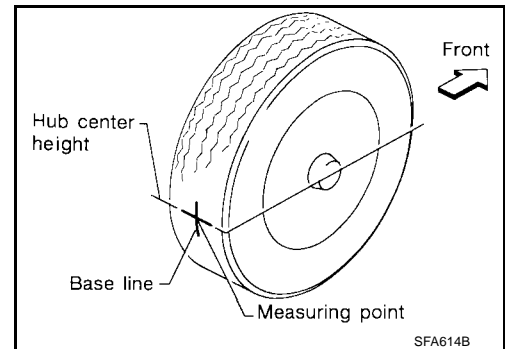

3. Put a mark on base line of the tread (rear side) of both tires at the same height of hub center. This mark is a measuring point.
4. Measure distance "A" (rear side).
5. Push the vehicle slowly ahead to rotate the wheels 180 degrees (1/2 turn).

If the wheels have rotated more than 180 degrees (1/2 turn), try the above procedure again from the beginning. Never push vehicle backward.

6. Measure distance "B" (front side).

Total toe-in : $A - B$
Refer to [RSU-13, "Rear Wheel Alignment \(Unladen*\)"](#) .

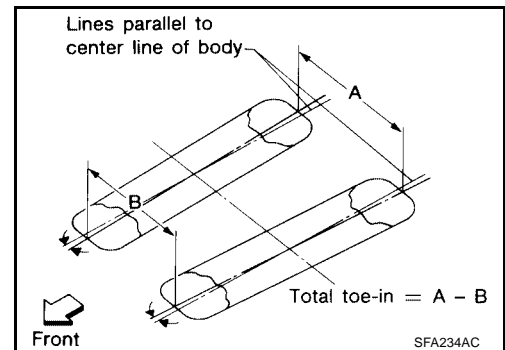

REMOVAL AND INSTALLATION

PFP:00000

EES0001Z

REMOVAL AND INSTALLATION

Removal and Installation REMOVAL

CAUTION:

- Before removing the rear suspension assembly, disconnect the ABS wheel sensor from the assembly. Failure to do so may result in damaged sensor wires and sensor becoming inoperative.

- Drain brake fluid before disconnecting brake lines.

1. Disconnect brake hydraulic lines and parking brake cables at toggle levers. (Models with drum brakes.)

2. Disconnect brake hydraulic lines and parking brake cables from calipers and remove brake calipers and rotors. (Models with disc brakes.)

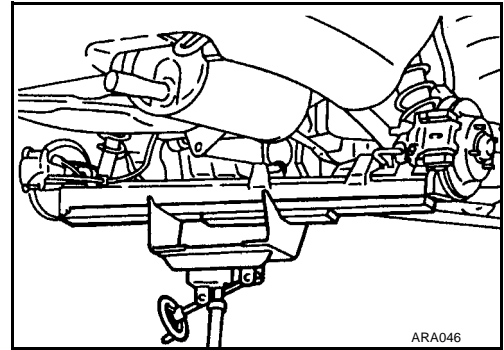

3. Disconnect ABS wheel sensor, if equipped.

4. Using a transmission jack, raise torsion beam a little, and remove nuts and bolts from the trailing arms, shock absorber assemblies (lower side) and lateral link.

5. Lower transmission jack and remove suspension.

6. Remove luggage compartment trim. Refer to [EI-33, "Removal and Installation"](#).

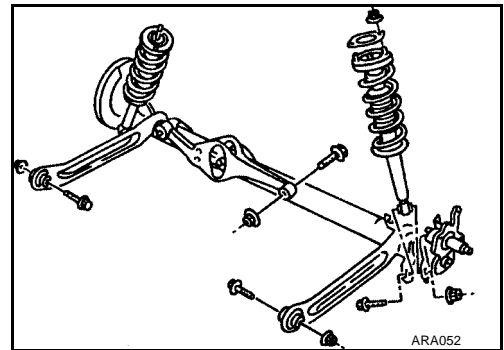

7. Remove shock absorber fixing nuts (upper side). Then pull out shock absorber assemblies.

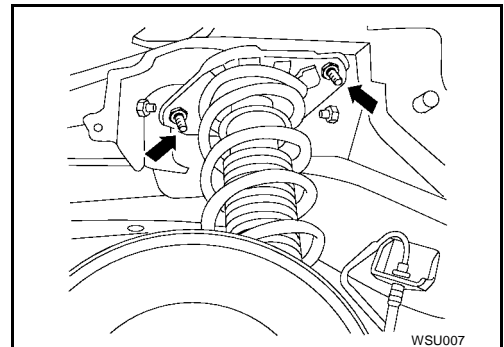

INSTALLATION

CAUTION:

- Refill with new brake fluid DOT 3.

- Never reuse drained brake fluid.

1. Attach torsion beam at trailing arm and lateral link to vehicle. Do not tighten bolts at this time.

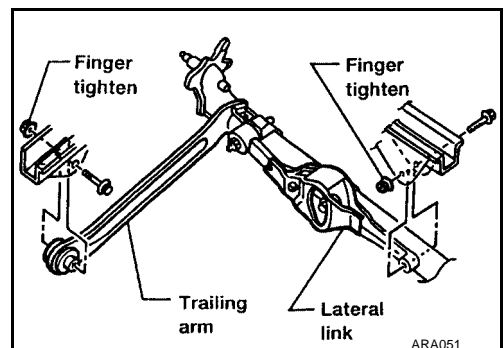

REMOVAL AND INSTALLATION

- Using a transmission jack, place lateral link and control rod horizontally against torsion beam. Tighten lateral link on vehicle.
- Attach shock absorber assembly to vehicle. Then tighten the lower side of shock absorber assembly.
- Lower torsion beam to fully extended position. Remove transmission jack and tighten torsion beam, at trailing arm, to specified torque. Refer to [RSU-5, "Components"](#).
- Install brake hydraulic lines and tighten flare nuts.

Flare nut tightening torque : 15 - 18 N·m (1.5 - 1.8 kg·m, 11 - 13 ft·lb)

- Connect ABS wheel sensor, if equipped.
- Bleed air. Refer to [BR-7, "Bleeding Brake System"](#).
- Install ABS wheel sensor.

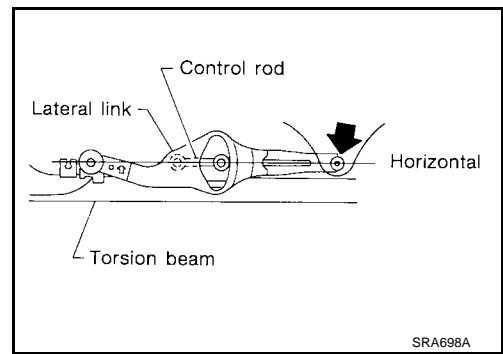

A
B
C
D

RSU

F
G
H
I
J
K
L
M

COIL SPRING AND SHOCK ABSORBER

COIL SPRING AND SHOCK ABSORBER

PFP:56210

Removal and Installation

EES000J0

Remove shock absorber upper and lower fixing nuts.

Do not remove piston rod lock nut on vehicle.

Disassembly

EES000J1

1. Set shock absorber in vise, then **loosen** piston rod lock nut. **Do not remove piston rod lock nut at this time.**
2. Compress spring with Tool so that the shock absorber upper spring seat can be turned by hand.

WARNING:

Make sure that the pawls of the two spring compressors are firmly hooked on the spring. The spring compressors must be tightened alternately so as not to tilt the spring.

3. Remove piston rod lock nut.

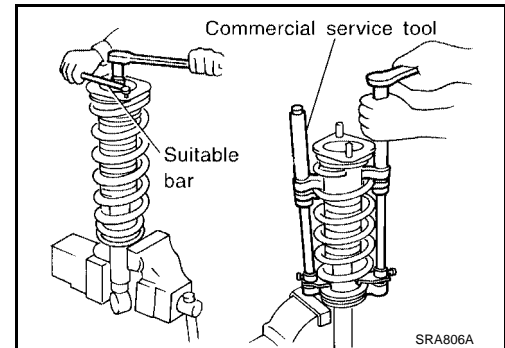

EES000J2

Inspection

SHOCK ABSORBER ASSEMBLY

- Check for smooth operation through a full stroke, both compression and extension.
- Check for oil leakage on welded or gland packing portions.
- Check piston rod for cracks, deformation or other damage. Replace if necessary.

UPPER RUBBER SEAT AND BUSHING

Check rubber parts for deterioration or cracks.

Replace if necessary.

COIL SPRING

Check for cracks, deformation or other damage. Replace if necessary.

Assembly

EES000J3

- Locate upper spring seat as shown.

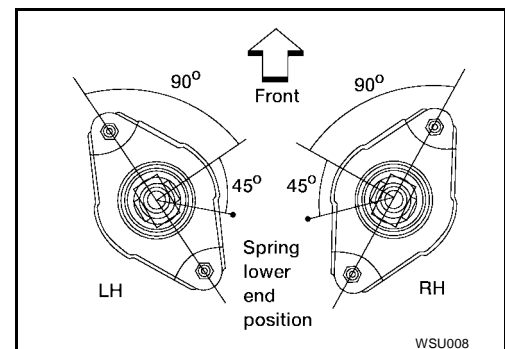

- When installing coil spring, be careful not to reverse top and bottom direction. (Top end is flat.)
- When installing coil spring on shock absorber, it must be positioned as shown.

CAUTION:

Do not reuse piston rod lock nut.

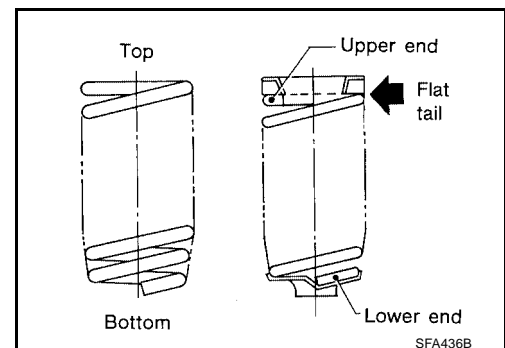

TORSION BEAM, LATERAL LINK AND CONTROL ROD

TORSION BEAM, LATERAL LINK AND CONTROL ROD

PF5:55130

Disassembly

EES000J4

- Remove torsion beam assembly. Refer to [RSU-8, "REMOVAL"](#).
- Remove lateral link and control rod from torsion beam.

Inspection

EES000J5

- Check for cracks, distortion or other damage. Replace if necessary.

Standard length : "A" 207 - 208 mm (8.15 - 8.19 in)
"B" 394 - 395 mm (15.51 - 15.55 in)
"C" 601 - 603 mm (23.66 - 23.74 in)
"D" 106 - 108 mm (4.17 - 4.25 in)

- Check all rubber parts for wear, cracks or deformation. Replace if necessary.

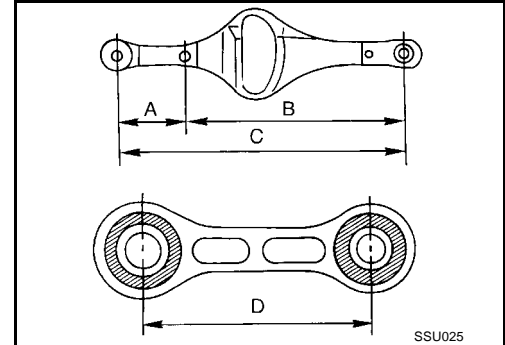

Rubber Bushing Replacement TRAILING ARM

EES000J6

Trailing arm bushings are press fit and must be centered properly in trailing arm collars.

1. Press out old bushing from trailing arm collar.
 2. Press in new bushing until inside edge of bushing is 16.7 to 17.7 mm (0.66 to 0.70 in) from inside edge of trailing arm.
- Do not allow bushing to incline more than 1 degree.
 - During installation, do not allow trailing arm to bend or twist.

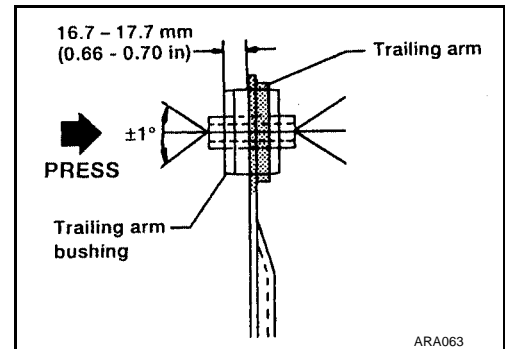

LATERAL LINK

Lateral link bushings are press fit. The large lateral link bushing is directional and must be installed in a specific position.

1. Remove lateral link.
2. Press out bushings. Note installation position of large bushing before removing.
3. Press in small bushing until bushing is centered in lateral link collar.
4. Press in large bushing until bushing is centered in lateral link collar.
 - a. Position bushing on lateral link collar.
 - b. Angle between bushing centerline and collar centerline must be within 3 degrees as shown in illustration.

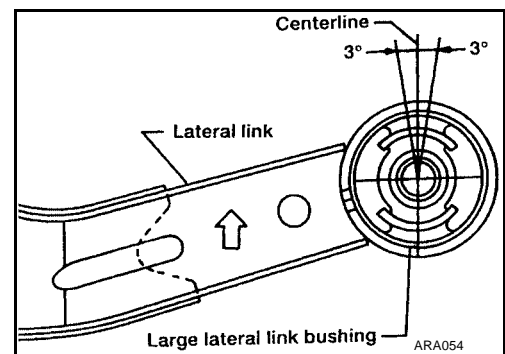

CONTROL ROD

Control rod bushings are not replaceable. If bushings are worn or damaged, replace control rod.

TORSION BEAM, LATERAL LINK AND CONTROL ROD

EES000J7

Assembly

1. Temporarily assemble lateral link and control rod.
 - When installing the control rod, connect the bushing with the smaller inner diameter to the lateral link.

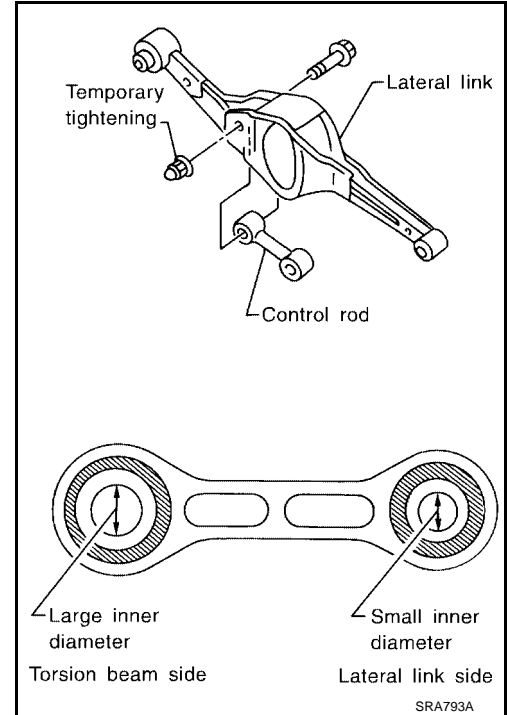

2. Temporarily install lateral link and control rod on torsion beam.
 - When installing, place lateral link with the arrow topside.

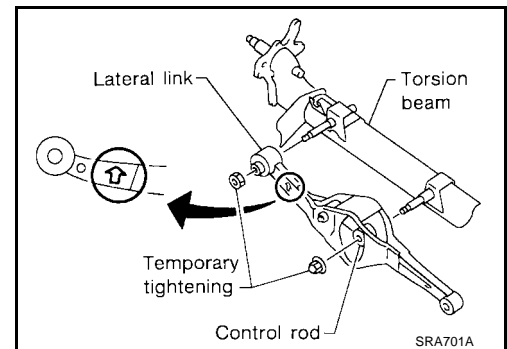

3. Place lateral link and control rod horizontally against torsion beam, and tighten to the specified torque.
4. Install torsion beam assembly. Refer to [RSU-8, "INSTALLATION"](#).

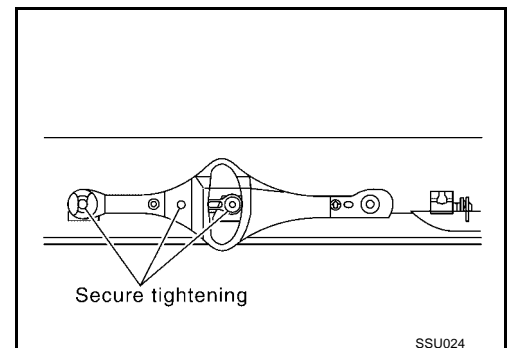

SERVICE DATA AND SPECIFICATIONS (SDS)

SERVICE DATA AND SPECIFICATIONS (SDS)

PF0:00030

General Specifications (Rear)

EES000J8

Suspension type	Multi-link beam suspension
Shock absorber type	Double-acting hydraulic

Rear Wheel Alignment (Unladen*)

EES000J9

Camber Degree minute (Decimal degree)		Minimum	-1°45' (-1.75°)
		Nominal	-1°00' (-1.00°)
		Maximum	-0°15' (-0.25°)
Total toe-in	Distance (A – B) mm (in)	Minimum	-3 (-0.12)
		Nominal	1 (0.04)
		Maximum	5 (0.20)
	Angle (left plus right) Degree minute (Decimal degree)	Minimum	-16' (-0.27°)
		Nominal	5'30" (0.09°)
		Maximum	26' (0.43°)

*: Fuel, radiator coolant and engine oil full. Spare tire, jack, hand tools and mats in designated positions.

Wheelarch Height (Unladen*)

EES000JA

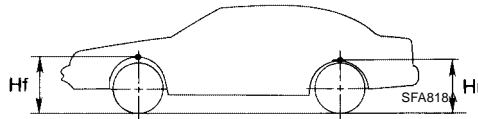

Engine Model	QG18DE	QR25DE	
		SE-R	SPEC-V
Tire Size	195/60HR15	195/55HR16	215/45ZR17
Front (Hf) mm (in)	664 (26.14)	660 (25.98)	664 (26.14)
Rear (Hr) mm (in)	658 (25.91)	652 (25.67)	655 (25.79)

*: Fuel, radiator coolant and engine oil full. Spare tire, jack, hand tools and mats in designated positions.

SERVICE DATA AND SPECIFICATIONS (SDS)
