

A
B
C
D
E

SECTION MTC

MANUAL AIR CONDITIONER

CONTENTS

<p>PRECAUTIONS 3</p> <p>Precautions for Supplemental Restraint System (SRS) "AIR BAG" and "SEAT BELT PRE-TENSIONER" 3</p> <p>Precautions for Working with HFC-134a (R-134a).... 3</p> <p>Contaminated Refrigerant 3</p> <p>General Refrigerant Precautions 4</p> <p>Precautions for Leak Detection Dye 4</p> <p>A/C Identification Label 4</p> <p>Precautions for Refrigerant Connection 5</p> <p>FEATURES OF NEW TYPE REFRIGERANT CONNECTION 5</p> <p>O-RING AND REFRIGERANT CONNECTION..... 6</p> <p>Precautions for Servicing Compressor 8</p> <p>Precautions for Service Equipment 8</p> <p>RECOVERY/RECYCLING EQUIPMENT 8</p> <p>ELECTRONIC LEAK DETECTOR 8</p> <p>VACUUM PUMP 9</p> <p>MANIFOLD GAUGE SET 9</p> <p>SERVICE HOSES 9</p> <p>SERVICE COUPLERS 10</p> <p>CHARGING CYLINDER 10</p> <p>Wiring Diagrams and Trouble Diagnosis 10</p> <p>PREPARATION11</p> <p>Special Service Tools11</p> <p>HFC-134a (R-134a) Service Tools and Equipment. 12</p> <p>COMMERCIAL SERVICE TOOL 14</p> <p>REFRIGERATION SYSTEM 15</p> <p>Refrigeration Cycle 15</p> <p>REFRIGERANT FLOW 15</p> <p>FREEZE PROTECTION 15</p> <p>REFRIGERANT SYSTEM PROTECTION 15</p> <p>LUBRICANT 16</p> <p>Maintenance of Lubricant Quantity in Compressor.. 16</p> <p>LUBRICANT 16</p> <p>CHECKING AND ADJUSTING 16</p> <p>TROUBLE DIAGNOSIS 19</p> <p>Component Layout 19</p> <p>Control Operation 20</p> <p>FAN CONTROL SWITCH 20</p>	<p>REAR WINDOW DEFOGGER SWITCH 20</p> <p>MODE CONTROL KNOB 20</p> <p>TEMPERATURE CONTROL KNOB 20</p> <p>RECIRCULATION (REC) SWITCH 20</p> <p>AIR CONDITIONER (A/C) SWITCH 20</p> <p>Discharge Air Flow 21</p> <p>System Description 22</p> <p>SWITCHES AND THEIR CONTROL FUNCTIONS 22</p> <p>Component Location 23</p> <p>ENGINE COMPARTMENT 23</p> <p>PASSENGER COMPARTMENT 24</p> <p>Wiring Diagram — Heater — 25</p> <p>QG18DE MODELS 25</p> <p>Wiring Diagram — A/C, M — 27</p> <p>QG18DE MODELS 27</p> <p>QR25DE MODELS 31</p> <p>How to Perform Trouble Diagnoses for Quick and Accurate Repair 34</p> <p>WORK FLOW 34</p> <p>SYMPTOM TABLE 34</p> <p>Operational Check 35</p> <p>CONDITIONS: 35</p> <p>PROCEDURE: 35</p> <p>Main Power Supply and Ground Circuit Check 37</p> <p>POWER SUPPLY CIRCUIT CHECK 37</p> <p>INTAKE DOOR 38</p> <p>Trouble Diagnosis Procedure for Intake Door 38</p> <p>Component Description 38</p> <p>INTAKE DOOR MOTOR 38</p> <p>Intake Door Motor Circuit 39</p> <p>Control Linkage Adjustment 41</p> <p>INTAKE DOOR MOTOR 41</p> <p>Mode Door 42</p> <p>TROUBLE DIAGNOSIS PROCEDURE FOR MODE DOOR 42</p> <p>CONTROL LINKAGE ADJUSTMENT 43</p> <p>Air Mix Door 44</p> <p>TROUBLE DIAGNOSIS PROCEDURE FOR AIR</p>
---	--

F
G
H
I
MTC
K
L
M

MIX DOOR	44	Inspection	72
Temperature Control Linkage Adjustment	45	CLUTCH DISC	72
BLOWER MOTOR	46	PULLEY	72
Trouble Diagnosis Procedure for Blower Motor	46	COIL	72
Blower Motor Circuit	46	Installation	72
Electrical Components Inspection	50	QG18DE	72
FAN CONTROL SWITCH	50	QR25DE	74
BLOWER MOTOR	50	Break-In Operation	75
FAN RESISTOR	50	THERMAL PROTECTOR	76
MAGNET CLUTCH	51	Inspection	76
Trouble Diagnosis Procedure for Magnet Clutch ...	51	IN-CABIN MICROFILTER	77
Magnet Clutch Circuit	52	Removal and Installation	77
Electrical Component Inspection	55	FUNCTION	77
A/C RELAY	55	REPLACEMENT TIMING	77
REFRIGERANT PRESSURE SENSOR	56	REPLACEMENT PROCEDURES	77
INSUFFICIENT COOLING	57	HEATER & COOLING UNIT (HEATER CORE)	78
Trouble Diagnosis Procedure for Insufficient Cool- ing	57	Removal	78
Performance Test Diagnoses	58	Installation	78
Performance Chart	60	BLOWER UNIT	79
TEST CONDITION	60	Removal	79
TEST READING	60	Installation	79
Trouble Diagnoses for Abnormal Pressure	61	A/C EVAPORATOR	80
BOTH HIGH AND LOW-PRESSURE SIDES ARE TOO HIGH.	61	Removal	80
HIGH-PRESSURE SIDE IS TOO HIGH AND LOW-PRESSURE SIDE IS TOO LOW.	61	Installation	81
HIGH-PRESSURE SIDE IS TOO LOW AND LOW-PRESSURE SIDE IS TOO HIGH.	62	REFRIGERANT LINES	82
BOTH HIGH- AND LOW-PRESSURE SIDES ARE TOO LOW.	62	HFC-134a (R-134a) Service Procedure	82
LOW-PRESSURE SIDE SOMETIMES BECOMES NEGATIVE.	63	SETTING OF SERVICE TOOLS AND EQUIP- MENT	82
LOW-PRESSURE SIDE BECOMES NEGATIVE. ... 63	63	Removal and Installation	84
INSUFFICIENT HEATING	64	QG18DE	84
Trouble Diagnosis Procedure for Insufficient Heat- ing	64	QR25DE	85
NOISE	65	Checking Refrigerant Leaks	86
Trouble Diagnosis Procedure for Noise	65	PRELIMINARY CHECK	86
INTAKE SENSOR	66	Electronic Refrigerant Leak Detector	86
Intake Sensor Circuit	66	PRECAUTIONS FOR HANDLING LEAK DETECTOR	86
COMPONENT DESCRIPTION	66	CHECKING PROCEDURE	87
DIAGNOSTIC PROCEDURE	66	Fluorescent Dye Leak Detector	88
Removal and Installation	67	PRECAUTIONS FOR FLUORESCENT DYE LEAK DETECTION	88
COMPRESSOR	68	CHECKING SYSTEM FOR LEAKS USING THE FLUORESCENT LEAK DETECTOR	88
Removal and Installation	68	DYE INJECTION	88
COMPRESSOR CLUTCH	69	BELT	90
Overhaul	69	Tension Adjustment	90
QG18DE	69	SERVICE DATA AND SPECIFICATIONS (SDS)	91
QR25DE	69	General Specifications	91
Removal	70	COMPRESSOR	91
QG18DE	70	LUBRICANT	91
QR25DE	71	REFRIGERANT	91
		Inspection and Adjustment	91
		ENGINE IDLING SPEED (WHEN A/C IS ON)	91
		BELT TENSION	91

PRECAUTIONS

PRECAUTIONS

PFP:00001

Precautions for Supplemental Restraint System (SRS) “AIR BAG” and “SEAT BELT PRE-TENSIONER”

EJS001QX

The Supplemental Restraint System such as “AIR BAG” and “SEAT BELT PRE-TENSIONER”, used along with a front seat belt, helps to reduce the risk or severity of injury to the driver and front passenger for certain types of collision. Information necessary to service the system safely is included in the SRS and SB section of this Service Manual.

WARNING:

- To avoid rendering the SRS inoperative, which could increase the risk of personal injury or death in the event of a collision which would result in air bag inflation, all maintenance must be performed by an authorized NISSAN/INFINITI dealer.
- Improper maintenance, including incorrect removal and installation of the SRS, can lead to personal injury caused by unintentional activation of the system. For removal of Spiral Cable and Air Bag Module, see the SRS section.
- Do not use electrical test equipment on any circuit related to the SRS unless instructed to in this Service Manual. SRS wiring harnesses can be identified by yellow and/or orange harnesses or harness connectors.

Precautions for Working with HFC-134a (R-134a)

EJS001A7

WARNING:

- CFC-12 (R-12) refrigerant and HFC-134a (R-134a) refrigerant are not compatible. If the refrigerants are mixed and compressor failure is likely to occur. Refer to [MTC-3, "Contaminated Refrigerant"](#). To determine the purity of HFC-134a (R-134a) in the vehicle and recovery tank, use Refrigerant Recovery/Recycling Recharging equipment and Refrigerant Identifier.
- Use only specified lubricant for the HFC-134a (R-134a) A/C system and HFC-134a (R-134a) components. If lubricant other than that specified is used, compressor failure is likely to occur.
- The specified HFC-134a (R-134a) lubricant rapidly absorbs moisture from the atmosphere. The following handling precautions must be observed:
 - When removing refrigerant components from a vehicle, immediately cap (seal) the component to minimize the entry of moisture from the atmosphere.
 - When installing refrigerant components to a vehicle, do not remove the caps (unseal) until just before connecting the components. Connect all refrigerant loop components as quickly as possible to minimize the entry of moisture into system.
 - Only use the specified lubricant from a sealed container. Immediately reseal containers of lubricant. Without proper sealing, lubricant will become moisture saturated and should not be used.
 - Avoid breathing A/C refrigerant and lubricant vapor or mist. Exposure may irritate eyes, nose and throat. Remove R-134a from the A/C system, using certified service equipment meeting requirements of SAE J2210 (R-134a recycling equipment), or J2209 (R-134a recovery equipment). If accidental system discharge occurs, ventilate work area before resuming service. Additional health and safety information may be obtained from refrigerant and lubricant manufacturers.
 - Do not allow A/C lubricant to come in contact with styrofoam parts. Damage may result.

Contaminated Refrigerant

EJS001A8

If a refrigerant other than pure R-134a is identified in a vehicle, your options are:

- Explain to the customer that environmental regulations prohibit the release of contaminated refrigerant into the atmosphere.
- Explain that recovery of the contaminated refrigerant could damage your service equipment and refrigerant supply.
- Suggest the customer return the vehicle to the location of previous service where the contamination may have occurred.
- If you choose to perform the repair, recover the refrigerant using only **dedicated equipment and containers. Do not recover contaminated refrigerant into your existing service equipment.** If your facility does not have dedicated recovery equipment, you may contact a local refrigerant product retailer for available service. This refrigerant must be disposed of in accordance with all federal and local regulations. In addition, replacement of all refrigerant system components on the vehicle is recommended.

A
B
C
D
E
F
G
H
I
K
L
M

MTC

PRECAUTIONS

- If the vehicle is within the warranty period, the air conditioner warranty is void. Please contact Nissan Customer Affairs for further assistance.

General Refrigerant Precautions

EJS001A9

WARNING:

- Do not release refrigerant into the air. Use approved recovery/recycling equipment to capture the refrigerant every time an air conditioning system is discharged.
- Always wear eye and hand protection (goggles and gloves) when working with any refrigerant or air conditioning system.
- Do not store or heat refrigerant containers above 52°C (125°F).
- Do not heat a refrigerant container with an open flame; if container warming is required, place the bottom of the container in a warm pail of water.
- Do not intentionally drop, puncture, or incinerate refrigerant containers.
- Keep refrigerant away from open flames: poisonous gas will be produced if refrigerant burns.
- Refrigerant will displace oxygen, therefore be certain to work in well ventilated areas to prevent suffocation.
- Do not pressure test or leak test HFC-134a (R-134a) service equipment and/or vehicle air conditioning systems with compressed air during repair. Some mixtures of air and R-134a have been shown to be combustible at elevated pressures. These mixtures, if ignited, may cause injury or property damage. Additional health and safety information may be obtained from refrigerant manufacturers.

Precautions for Leak Detection Dye

EJS001AA

- The A/C system contains a fluorescent leak detection dye used for locating refrigerant leaks. An ultraviolet (UV) lamp is required to illuminate the dye when inspecting for leaks.
- Always wear fluorescence enhancing UV safety glasses to protect your eyes and enhance the visibility of the fluorescent dye.
- A compressor shaft seal should not be repaired because of dye seepage. The compressor shaft seal should only be repaired after confirming the leak with an electronic refrigerant leak detector (J-41995).
- Always remove any dye from the leak area after repairs are complete to avoid a misdiagnosis during a future service.
- Do not allow dye to come into contact with painted body panels or interior components. If dye is spilled, clean immediately with the approved dye cleaner. Fluorescent dye left on a surface for an extended period of time **cannot be removed**.
- Do not spray the fluorescent dye cleaning agent on hot surfaces (engine exhaust manifold, etc.).
- Do not use more than one refrigerant dye bottle (1/4 ounce / 7.4 cc) per A/C system.
- Leak detection dyes for R-134a and R-12 A/C systems are different. Do not use R-134a leak detection dye in R-12 A/C systems or R-12 leak detection dye in R-134a A/C systems or A/C system damage may result.
- The fluorescent properties of the dye will remain for over three (3) years unless a compressor failure occurs.

A/C Identification Label

EJS001AB

Vehicles are equipped factory installed fluorescent dye and have this identification label on the under side of hood.

NOTE:

Vehicles equipped with factory installed fluorescent dye have a green label.

AIR CONDITIONER NISSAN		
	REFRIGERANT	COMPRESSOR LUBRICANT
TYPE (PART NO.)	HFC134a (R134a)	Nissan UV Luminous Oil Type R [KLH00-PAGR0]
AMOUNT		
CAUTION PRECAUTION		
• REFRIGERANT UNDER HIGH PRESSURE.		
• SYSTEM TO BE SERVICED BY QUALIFIED PERSONNEL.		
• IMPROPER SERVICE METHODS MAY CAUSE PERSONAL INJURY.		
• CONSULT SERVICE MANUAL.		
• THIS AIR CONDITIONER SYSTEM COMPLIES WITH SAE J-639.		
Nissan Motor Co., Ltd., TOKYO, Japan		
27090 6P102		
LHA175		

PRECAUTIONS

EJS001AC

Precautions for Refrigerant Connection FEATURES OF NEW TYPE REFRIGERANT CONNECTION

- The O-ring has been relocated. It has also been provided with a groove for proper installation. This eliminates the chance of the O-ring being caught in, or damaged by, the mating part. The sealing direction of the O-ring is now set vertically in relation to the contacting surface of the mating part to improve sealing characteristics.
- The reaction force of the O-ring will not occur in the direction that causes the joint to pull out, thereby facilitating piping connections.

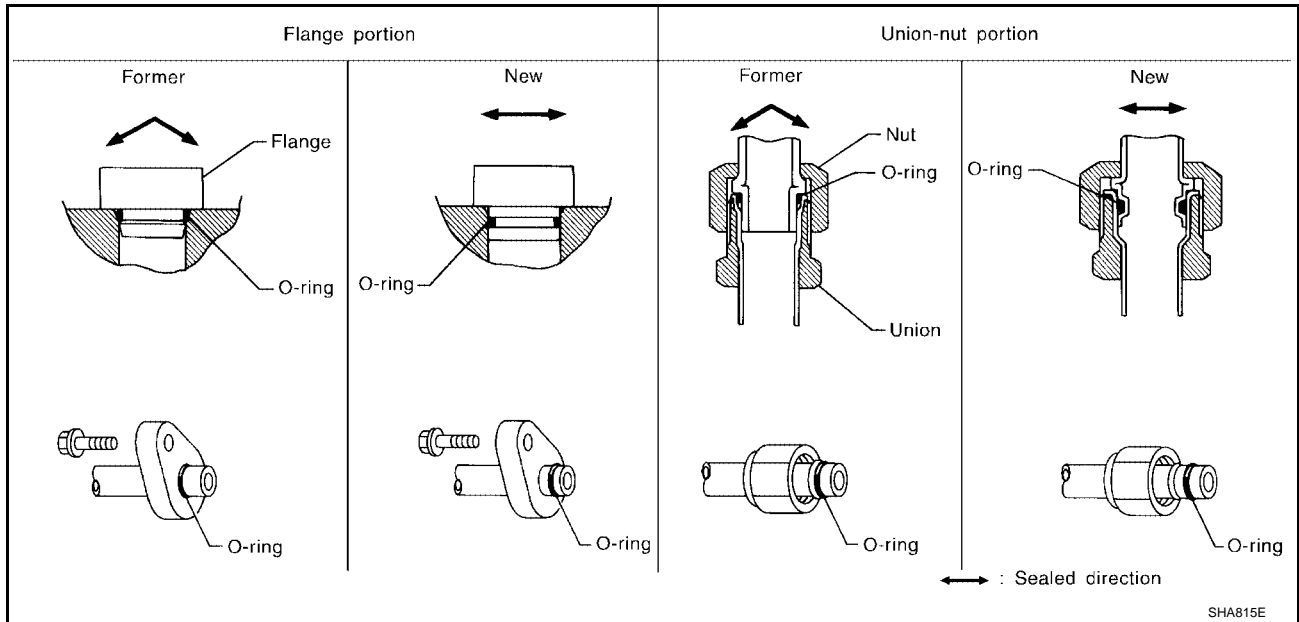

A
B
C
D
E
F
G
H
I

MTC

K
L
M

PRECAUTIONS

O-RING AND REFRIGERANT CONNECTION

QG18DE

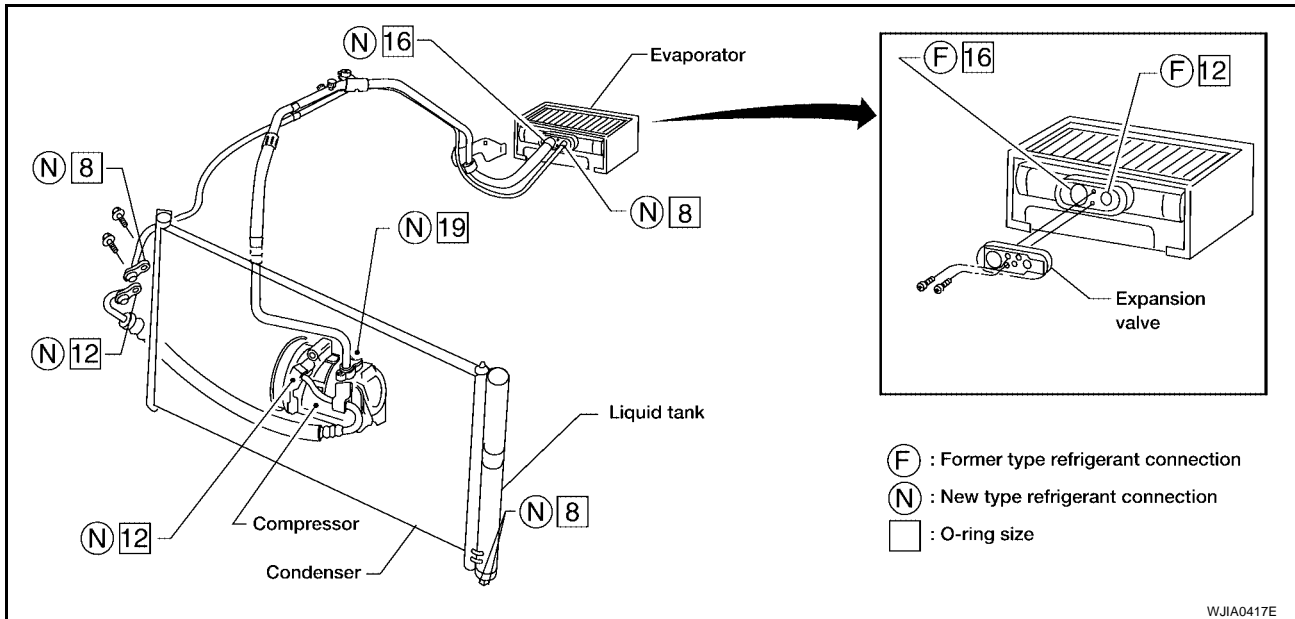

QR25DE

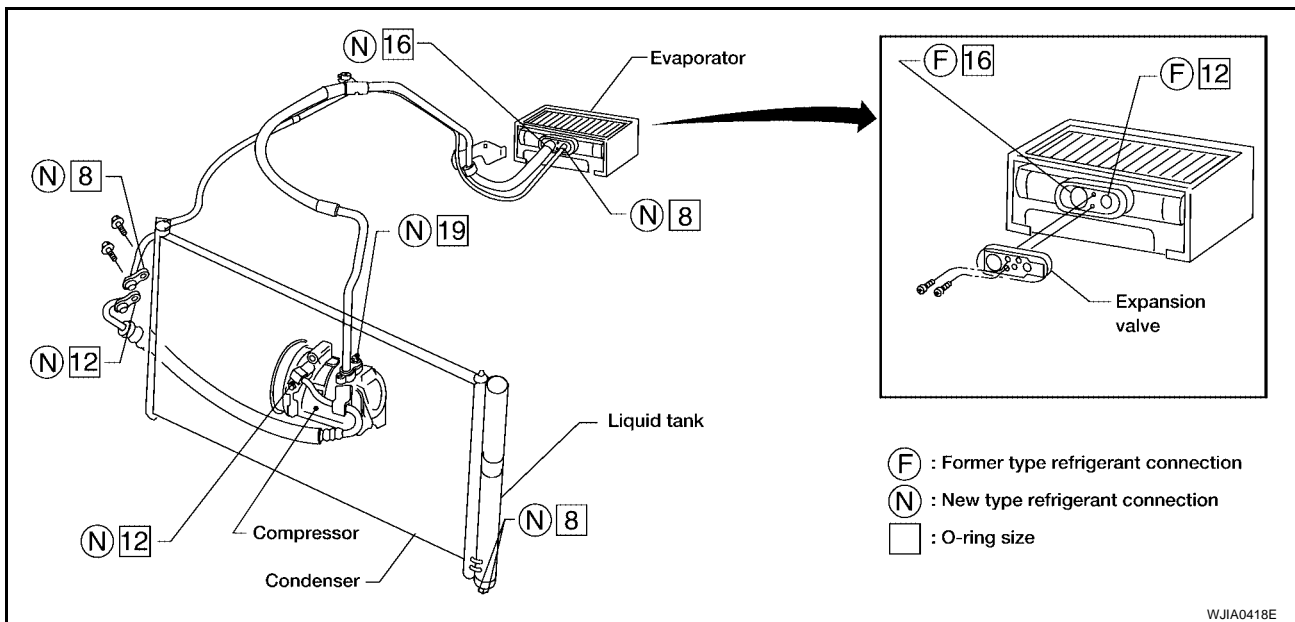

CAUTION:

The new and former refrigerant connections in some systems use different O-ring configurations. Do not confuse O-rings since they are not interchangeable. If a wrong O-ring is installed, refrigerant will leak at, or around, the connection.

PRECAUTIONS

O-Ring Part Numbers and Specifications

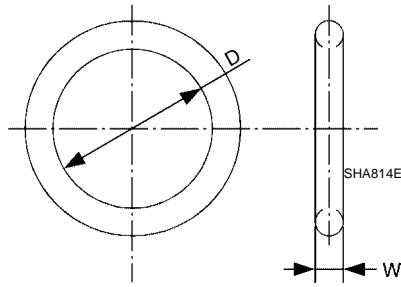

Connection type	O-ring size	Part number*	D mm (in)	W mm (in)
New	8	92471 N8210	6.8 (0.268)	1.85 (0.0728)
Former	12	92475 71L00	10.8 (0.425)	1.78 (0.0701)
New	12	92472 N8210	10.9 (0.429)	3.65 (0.1437)
Former	16	92475 72L00	13.9 (0.547)	1.78 (0.0701)
New	16	92473 N8210	13.6 (0.535)	2.43 (0.0957)
New	19	92474 N8210	16.5 (0.650)	2.43 (0.0957)

*: Always check with the Parts Department for the latest parts information.

WARNING:

Make sure all refrigerant is discharged into the recycling equipment and the pressure in the system is less than atmospheric pressure. Then gradually loosen the discharge side hose fitting and remove it.

CAUTION:

When replacing or cleaning refrigerant cycle components, observe the following.

- When the compressor is removed, store it in the same position as it is when mounted on the car. Failure to do so will cause lubricant to enter the low pressure chamber.
- When connecting tubes, always use a torque wrench and a back-up wrench.
- After disconnecting tubes, immediately plug all openings to prevent entry of dirt and moisture.
- When installing an air conditioner in the vehicle, connect the pipes as the final stage of the operation. Do not remove the seal caps of pipes and other components until just before required for connection.
- Allow components stored in cool areas to warm to working area temperature before removing seal caps. This prevents condensation from forming inside A/C components.
- Thoroughly remove moisture from the refrigeration system before charging the refrigerant.
- Always replace used O-rings.
- When connecting tube, apply lubricant to circle of the O-rings shown in illustration. Be careful not to apply lubricant to threaded portion.
Lubricant name: Genuine Nissan A/C System Lubricant Type R or equivalent
Part number: KLH00-PAGRO
- O-ring must be closely attached to dented portion of tube.
- When replacing the O-ring, be careful not to damage O-ring and tube.
- Connect tube until you hear it click, then tighten the nut or bolt by hand until snug. Make sure that the O-ring is installed to tube correctly.

A
B
C
D
E
F
G
H
I
K
L
M

MTC

PRECAUTIONS

- After connecting line, conduct leak test and make sure that there is no leakage from connections. When the gas leaking point is found, disconnect that line and replace the O-ring. Then tighten connections of seal seat to the specified torque.

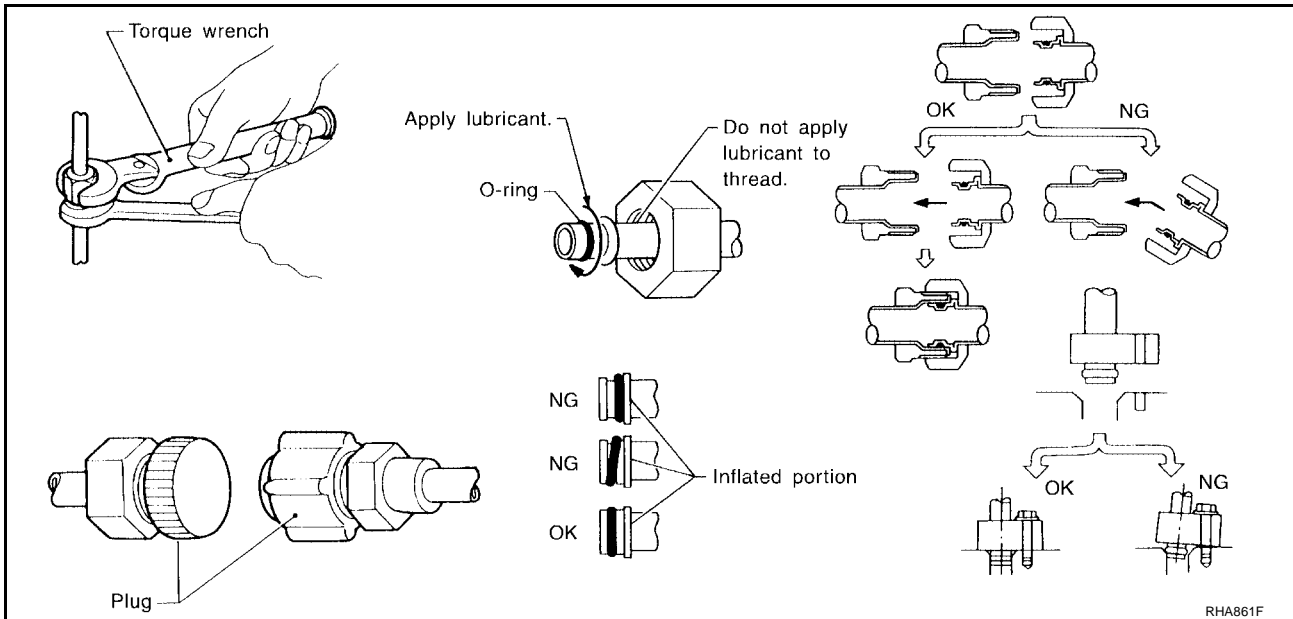

Precautions for Servicing Compressor

EJS001AD

- Plug all openings to prevent moisture and foreign matter from entering.
- When the compressor is removed, store it in the same position as it is when mounted on the car.
- When replacing or repairing compressor, follow "Maintenance of Lubricant Quantity in Compressor" exactly. Refer to [MTC-16, "Maintenance of Lubricant Quantity in Compressor"](#).
- Keep friction surfaces between clutch and pulley clean. If the surface is contaminated, with lubricant, wipe it off by using a clean waste cloth moistened with thinner.
- After compressor service operation, turn the compressor shaft by hand more than five turns in both directions. This will equally distribute lubricant inside the compressor. After the compressor is installed, let the engine idle and operate the compressor for one hour.
- After replacing the compressor magnet clutch, apply voltage to the new one and check for normal operation. [Gap between clutch disc and pulley is 0.3 - 0.6 mm (0.012 - 0.024 in)]

Precautions for Service Equipment RECOVERY/RECYCLING EQUIPMENT

EJS001AE

Follow the manufacturer's instructions for machine operation and machine maintenance. Never introduce any refrigerant other than that specified into the machine.

ELECTRONIC LEAK DETECTOR

Follow the manufacturer's instructions for tester operation and tester maintenance.

PRECAUTIONS

VACUUM PUMP

The lubricant contained inside the vacuum pump is not compatible with the specified lubricant for HFC-134a (R-134a) A/C systems. The vent side of the vacuum pump is exposed to atmospheric pressure so the vacuum pump lubricant may migrate out of the pump into the service hose. This is possible when the pump is switched off after evacuation (vacuuming) and hose is connected to it. To prevent this migration, use a manual valve situated near the hose-to-pump connection, as follows.

- Usually vacuum pumps have a manual isolator valve as part of the pump. Close this valve to isolate the service hose from the pump.
- For pumps without an isolator, use a hose equipped with a manual shut-off valve near the pump end. Close the valve to isolate the hose from the pump.
- If the hose has an automatic shut off valve, disconnect the hose from the pump: as long as the hose is connected, the valve is open and lubricating oil may migrate.

Some one-way valves open when vacuum is applied and close under a no vacuum condition. Such valves may restrict the pump's ability to pull a deep vacuum and are not recommended.

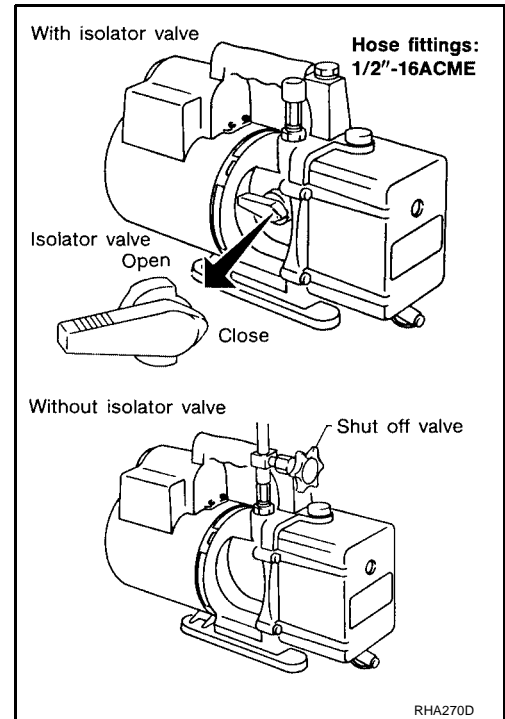

MANIFOLD GAUGE SET

Be certain that the gauge face indicates R-134a or 134a. Make sure the gauge set has 1/2"-16 ACME threaded connections for service hoses. Confirm the set has been used only with refrigerant HFC-134a (R-134a) along with specified lubricant.

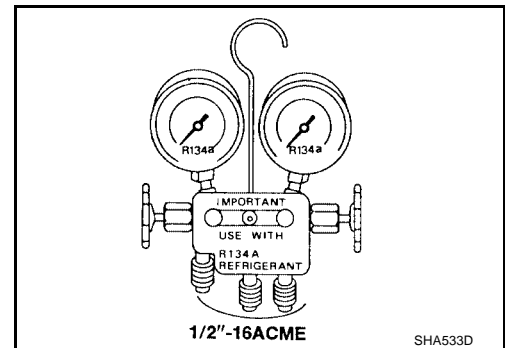

SERVICE HOSES

Be certain that the service hoses display the markings described (colored hose with black stripe). All hoses must include positive shut off devices (either manual or automatic) near the end of the hoses opposite the manifold gauge.

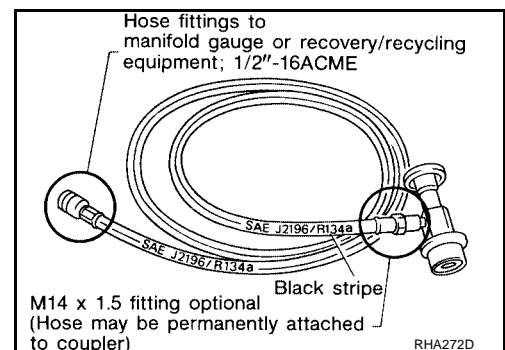

A
B
C
D
E
F
G
H
I
K
L
M

MTC

PRECAUTIONS

SERVICE COUPLERS

Never attempt to connect HFC-134a (R-134a) service couplers to an CFC-12 (R-12) A/C system. The HFC-134a (R-134a) couplers will not properly connect to the CFC-12 (R-12) system. However, if an improper connection is attempted, discharging and contamination may occur.

Shut-off valve rotation	A/C service valve
Clockwise	Open
Counterclockwise	Close

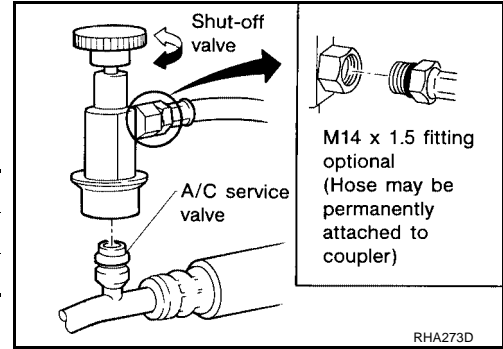

CHARGING CYLINDER

Using a charging cylinder is not recommended. Refrigerant may be vented into air from cylinder's top valve when filling the cylinder with refrigerant. Also, the accuracy of the cylinder is generally less than that of an electronic scale or of quality recycle/recharge equipment.

Wiring Diagrams and Trouble Diagnosis

EJS001AF

When you read wiring diagrams, refer to the following:

- [GI-13, "How to Read Wiring Diagrams"](#)
- [PG-5, "Wiring Diagram — POWER —"](#)

When you perform trouble diagnosis, refer to the following:

- [GI-9, "How to Follow Trouble Diagnoses"](#)
- [GI-26, "How to Perform Efficient Diagnosis for an Electrical Incident"](#)

PREPARATION

PREPARATION

PF0:00002

Special Service Tools

EJS001AG

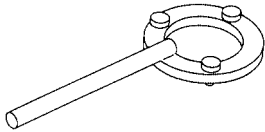
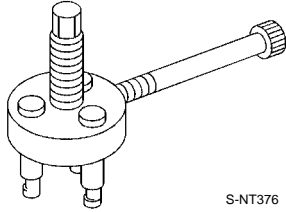
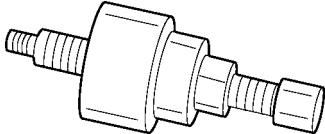
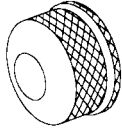
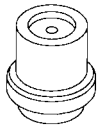
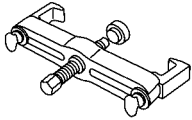
Tool number (Kent-Moore No.) Tool name	Description
KV99231260 (J-38874) Clutch disc wrench  NT204	Removing shaft nut and clutch disc
KV99232340 (J-38874) Clutch disc puller  S-NT376	Removing clutch disc
(J-38873-A) Drive plate installer  WJIA0367E	Installing pulley and drive plate
KV99234330 (J-39024) Pulley installer  NT207	Installing pulley
KV99233130 (J-39023) Pulley puller  NT208	Removing pulley
KV99233130 (J-29884) (with small adaptor) Pulley puller  LHA172	Removing pulley

A
B
C
D
E
F
G
H
I
K
L
M

MTC

PREPARATION

EJS001AH



HFC-134a (R-134a) Service Tools and Equipment

Never mix HFC-134a refrigerant and/or its specified lubricant with CFC-12 (R-12) refrigerant and/or its lubricant.

Separate and non-interchangeable service equipment must be used for handling each type of refrigerant/lubricant.

Refrigerant container fittings, service hose fittings and service equipment fittings (equipment which handles refrigerant and/or lubricant) are different between CFC-12 (R-12) and HFC-134a (R-134a). This is to avoid mixed use of the refrigerants/lubricant.

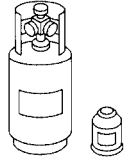
Adapters that convert one size fitting to another must never be used: refrigerant/lubricant contamination will occur and compressor failure will result.

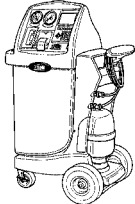
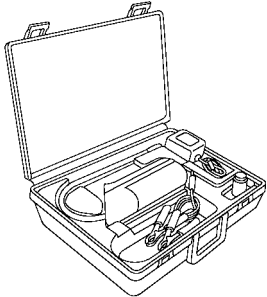
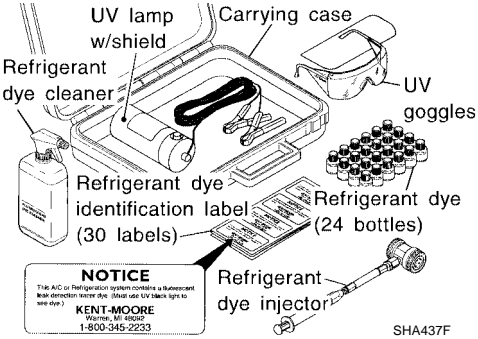
Tool number (Kent-Moore No.) Tool name	Description
HFC-134a (R-134a) refrigerant  S-NT196	Container color: Light blue Container marking: HFC-134a (R-134a) Fitting size: Thread size ● large container 1/2 ² -16 ACME
KLH00-PAGR0 (–) Genuine Nissan A/C System Lubricant Type R  S-NT197	Type: Poly alkylene glycol oil (PAG), type R Application: HFC-134a (R-134a) vane rotary compressors (Nissan only) Lubricity: 40 ml [Litre] (1.4 US fl oz, 1.4 Imp fl oz)
(J-43600) Recovery/Recycling Recharging equipment (ACR2000)  WJIA0293E	Function: Refrigerant Recovery and Recycling and Recharging
(J-41995) Electrical leak detector  AHA281A	Power supply: ● DC 12V (Cigarette lighter)
(J-43926) Refrigerant dye leak detection kit Kit includes: (J-42220) UV lamp and UV safety glasses (J-41459) Refrigerant dye injector (J-41447) qty. 24 HFC-134a (R-134a) refrigerant dye (J-43872) Refrigerant dye cleaner  SHA437F	Power supply: DC 12V (Battery terminal)

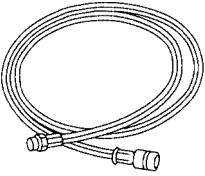

PREPARATION

Tool number (Kent-Moore No.) Tool name	Description	A
(J-42220) Fluorescent dye leak detector	 <p>Power supply: DC 12V (Battery terminal) For checking refrigerant leak when fluorescent dye is installed in A/C system. Includes: UV lamp and UV safety glasses</p> <p style="text-align: center;">SHA438F</p>	B C
(J-41447) HFC-134a (R-134a) Fluorescent leak detection dye (Box of 24, 1/4 ounce bottles)	 <p>Application: For HFC-134a (R-134a) PAG oil Container: 1/4 ounce (7.4cc) bottle (Includes self-adhesive dye identification labels for affixing to vehicle after charging system with dye.)</p> <p style="text-align: center;">Refrigerant dye (24 bottles)</p> <p style="text-align: center;">SHA439F</p>	D E
(J-41459) HFC-134a (R-134a) Dye injector Use with J-41447, 1/4 ounce bottle	 <p>For injecting 1/4 ounce of fluorescent leak detection dye into A/C system.</p> <p style="text-align: center;">SHA440F</p>	F G H
(J-43872) Dye cleaner	 <p>For cleaning dye spills.</p> <p style="text-align: center;">SHA441F</p>	I MTC
(J-39183) Manifold gauge set (with hoses and couplers)	 <p>Identification:</p> <ul style="list-style-type: none"> ● The gauge face indicates R-134a. <li style="padding-left: 20px;">Fitting size: Thread size ● 1/2² -16 ACME <p style="text-align: center;">RJIA0196E</p>	K L M
Service hoses <ul style="list-style-type: none"> ● High side hose (J-39501-72) ● Low side hose (J-39502-72) ● Utility hose (J-39476-72) 	 <p>Hose color:</p> <ul style="list-style-type: none"> ● Low hose: Blue with black stripe ● High hose: Red with black stripe ● Utility hose: Yellow with black stripe or green with black stripe <p>Hose fitting to gauge:</p> <ul style="list-style-type: none"> ● 1/2² -16 ACME <p style="text-align: center;">S-NT201</p>	

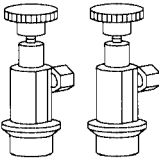
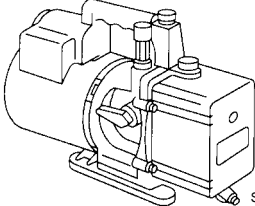
PREPARATION

Tool number (Kent-Moore No.) Tool name	Description
Service couplers <ul style="list-style-type: none"> ● High side coupler (J-39500-20) ● Low side coupler (J-39500-24) 	<div style="text-align: center;">  <p style="font-size: small; margin-top: 5px;">S-NT202</p> </div> <p>Hose fitting to service hose:</p> <ul style="list-style-type: none"> ● M14 x 1.5 fitting is optional or permanently attached.
(J-39649) Vacuum pump (Including the isolator valve)	<div style="text-align: center;">  <p style="font-size: small; margin-top: 5px;">S-NT203</p> </div> <p>Capacity:</p> <ul style="list-style-type: none"> ● Air displacement: 4 CFM ● Micron rating: 20 microns ● Oil capacity: 482 g (17 oz) Fitting size: Thread size ● 1/2² -16 ACME

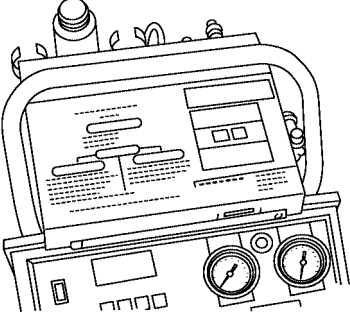
COMMERCIAL SERVICE TOOL

Tool name	Description
(J-41810-NI) Refrigerant identifier equipment (R-134a)	<div style="text-align: center;">  <p style="font-size: small; margin-top: 5px;">RJIA0197E</p> </div> <p>For checking refrigerant purity and for system contamination</p>
(J-44614) Clutch disc holding tool	<div style="text-align: center;">  </div> <p>For holding clutch disc</p>

REFRIGERATION SYSTEM

PFP:KA990

EJS001AI

REFRIGERATION SYSTEM

Refrigeration Cycle REFRIGERANT FLOW

The refrigerant flows in the standard pattern, that is, through the compressor, the condenser, the liquid tank, through the evaporator, and back to the compressor. The refrigerant evaporation through the evaporator coil is controlled by an externally equalized expansion valve, located inside the evaporator case.

FREEZE PROTECTION

The compressor cycles go on and off to maintain the evaporator temperature within a specified range. When the evaporator coil temperature falls below a specified point, the intake sensor interrupts the compressor operation. When the evaporator coil temperature rises above the specification, the thermo control amplifier allows compressor operation.

REFRIGERANT SYSTEM PROTECTION

Refrigerant Pressure Sensor

The refrigerant system is protected against excessively high or low pressures by the refrigerant pressure sensor, located on the refrigerant lines where they attach to the condenser. If the system pressure rises above or falls below the specifications, the refrigerant pressure sensor detects the pressure inside the refrigerant line and sends the voltage signal to the ECM. The ECM turns the A/C relay OFF and stops the compressor when pressure on the high pressure side detected by refrigerant pressure sensor is over about 2,746 kPa (28 kg/cm², 398 psi) or below about 177 kPa (1.8 kg/cm², 26 psi).

Pressure Relief Valve

The refrigerant system is also protected by a pressure relief valve, located in the rear head of the compressor. When the pressure of refrigerant in the system increases to an abnormal level [more than 3,727 kPa (38 kg/cm², 540 psi)], the release port on the pressure relief valve automatically opens and releases refrigerant into the atmosphere.

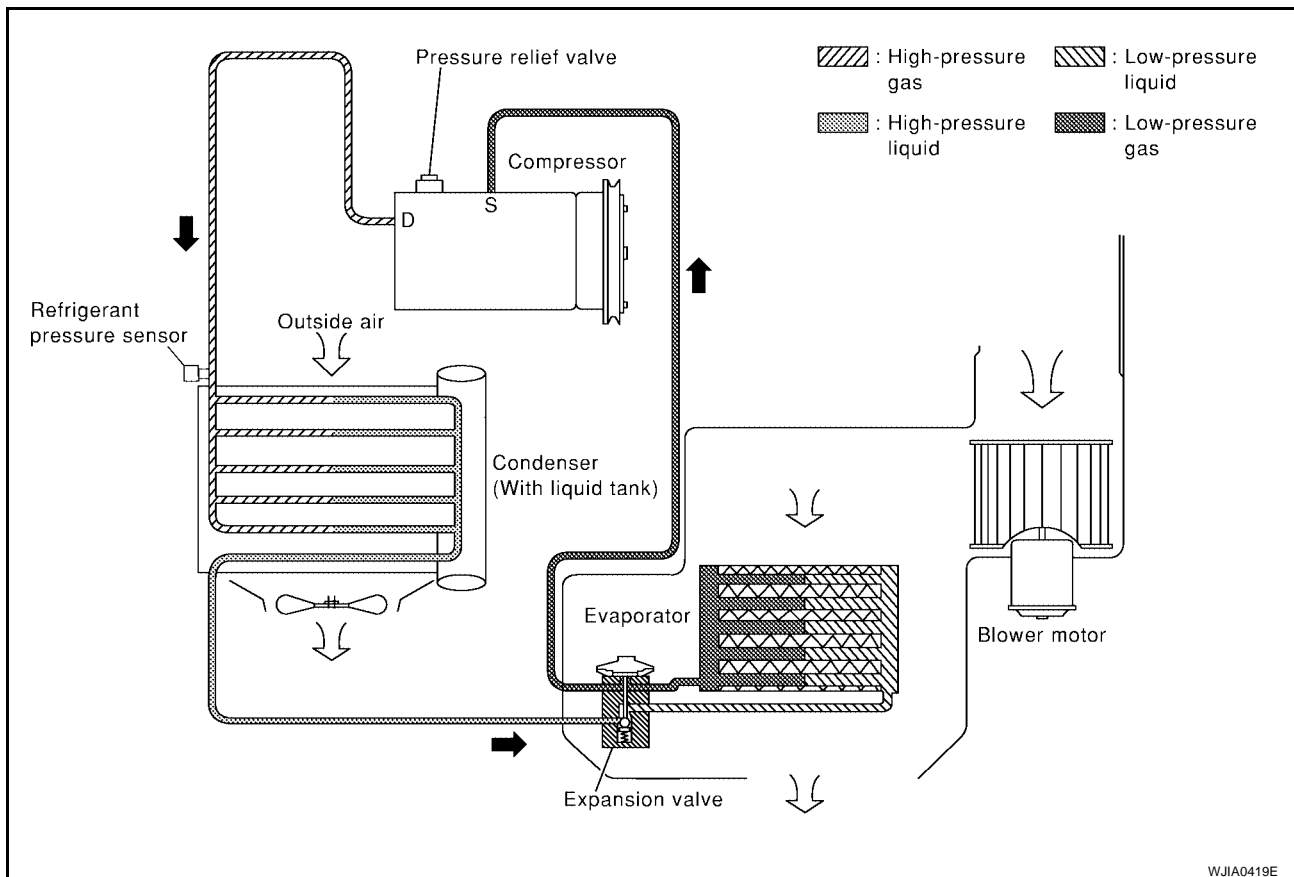

A

B

C

D

E

F

G

H

I

MTC

K

L

M

LUBRICANT

Maintenance of Lubricant Quantity in Compressor

EJS001AJ

The lubricant in the compressor circulates through the system with the refrigerant. Add lubricant to compressor when replacing any component or after a large refrigerant leakage has occurred. It is important to maintain the specified amount.

If lubricant quantity is not maintained properly, the following malfunctions may result:

- Lack of lubricant: May lead to a seized compressor
- Excessive lubricant: Inadequate cooling (thermal exchange interference)

LUBRICANT

Name: Genuine Nissan A/C System Lubricant Type R or equivalent

Part number: KLH00-PAGR0

CHECKING AND ADJUSTING

Adjust the lubricant quantity according to the test group shown below.

1. LUBRICANT RETURN OPERATION

Can lubricant return operation be performed?

- A/C system works properly.
- There is no evidence of a large amount of lubricant leakage.

Yes or No

Yes >> GO TO 2.

No >> GO TO 3.

2. PERFORM LUBRICANT RETURN OPERATION

1. Start engine, and set the following conditions:
 - **Test condition**
 - Engine speed: Idling to 1,200 rpm**
 - A/C switch: ON**
 - Blower speed: Max. position**
2. Perform lubricant return operation for about 10 minutes.
3. Stop engine.

CAUTION:

If excessive lubricant leakage is noted, do not perform the lubricant return operation.

>> GO TO 3.

3. CHECK COMPRESSOR

Should the compressor be replaced?

Yes or No

Yes >> GO TO [MTC-68. "Removal and Installation"](#) .

No >> GO TO 4.

4. CHECK ANY PART

Is there any part to be replaced? (Evaporator, condenser, liquid tank or in case there is evidence of a large amount of lubricant leakage.)

Yes or No

Yes >> GO TO [MTC-17. "Lubricant Adjusting Procedure for Components Replacement Except Compressor"](#) .

No >> Carry out the A/C performance test.

LUBRICANT

Lubricant Adjusting Procedure for Components Replacement Except Compressor

After replacing any of the following major components, add the correct amount of lubricant to the system.

Amount of lubricant to be added

Part replaced	Lubricant to be added to system	Remarks
	Amount of lubricant ml (US fl oz, Imp fl oz)	
Evaporator	75 (2.5, 2.6)	—
Condenser	75 (2.5, 2.6)	—
Liquid tank	5 (0.2, 0.2)	Add if compressor is not replaced.
In case of refrigerant leak	30 (1.0, 1.1)	Large leak
	—	Small leak *1

- *1: If refrigerant leak is small, no addition of lubricant is needed.

Lubricant Adjustment Procedure for Compressor Replacement

- Before connecting the recovery/recycling recharging equipment to the vehicle, check the recovery/recycling recharging equipment gauges. No refrigerant pressure should be displayed. If OK, recover refrigerant from equipment lines.
- Confirm refrigerant purity in supply tank using recovery/recycling recharging equipment and refrigerant identifier. If NG, refer to [MTC-3, "Contaminated Refrigerant"](#).
- Connect recovery/recycling recharging equipment to the vehicle. Confirm refrigerant purity in vehicle A/C system using recovery/recycling recharging equipment and refrigerant identifier. If NG, refer to [MTC-3, "Contaminated Refrigerant"](#).
- Discharge refrigerant into the refrigerant recovery/recycling recharging equipment. Measure lubricant discharged into the recovery/recycling recharging equipment.
- Drain the lubricant from the "old" (removed) compressor into a graduated container and recover the amount of lubricant drained.
- Drain the lubricant from the "new" compressor into a separate, clean container.
- Measure an amount of new lubricant installed equal to amount drained from "old" compressor. Add this lubricant to "new" compressor through the suction port opening.
- Measure an amount of new lubricant equal to the amount recovered during discharging. Add this lubricant to "new" compressor through the suction port opening.
- If the liquid tank also needs to be replaced, add an additional 5 ml (0.2 US fl oz, 0.2 Imp fl oz) of lubricant at this time.

Do not add this 5 ml (0.2 US fl oz, 0.2 Imp fl oz) of lubricant if only replacing the compressor.

LUBRICANT

Lubricant adjusting procedure for compressor replacement

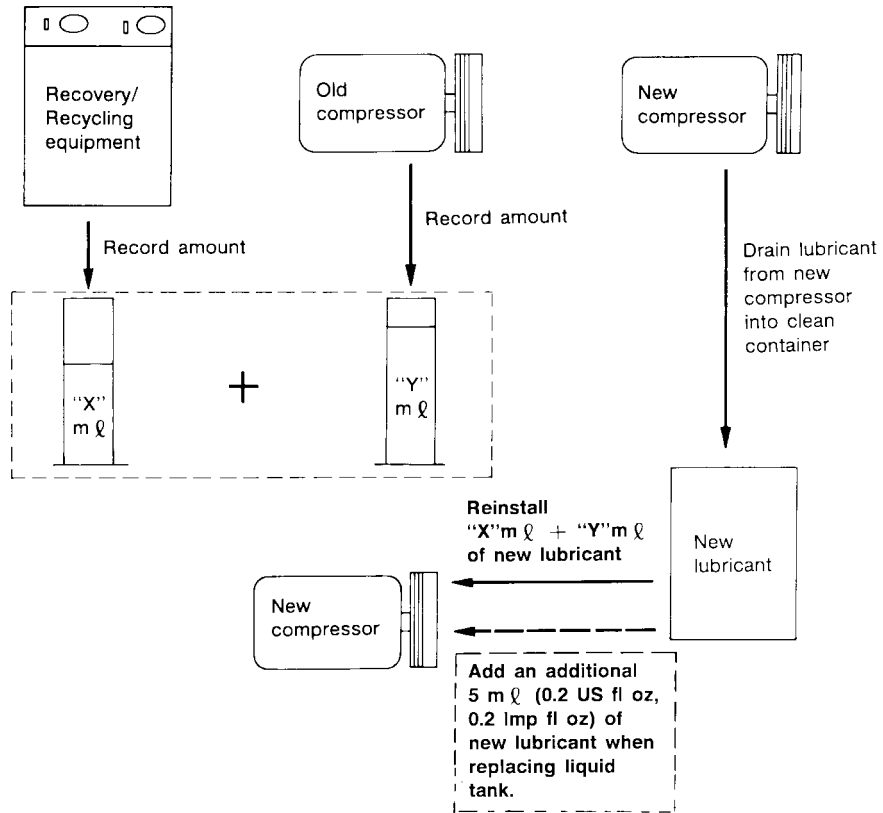

RHA065DD

TROUBLE DIAGNOSIS

TROUBLE DIAGNOSIS

PFP:00004

Component Layout

EJS001AK

SEC. 270•271•272•273

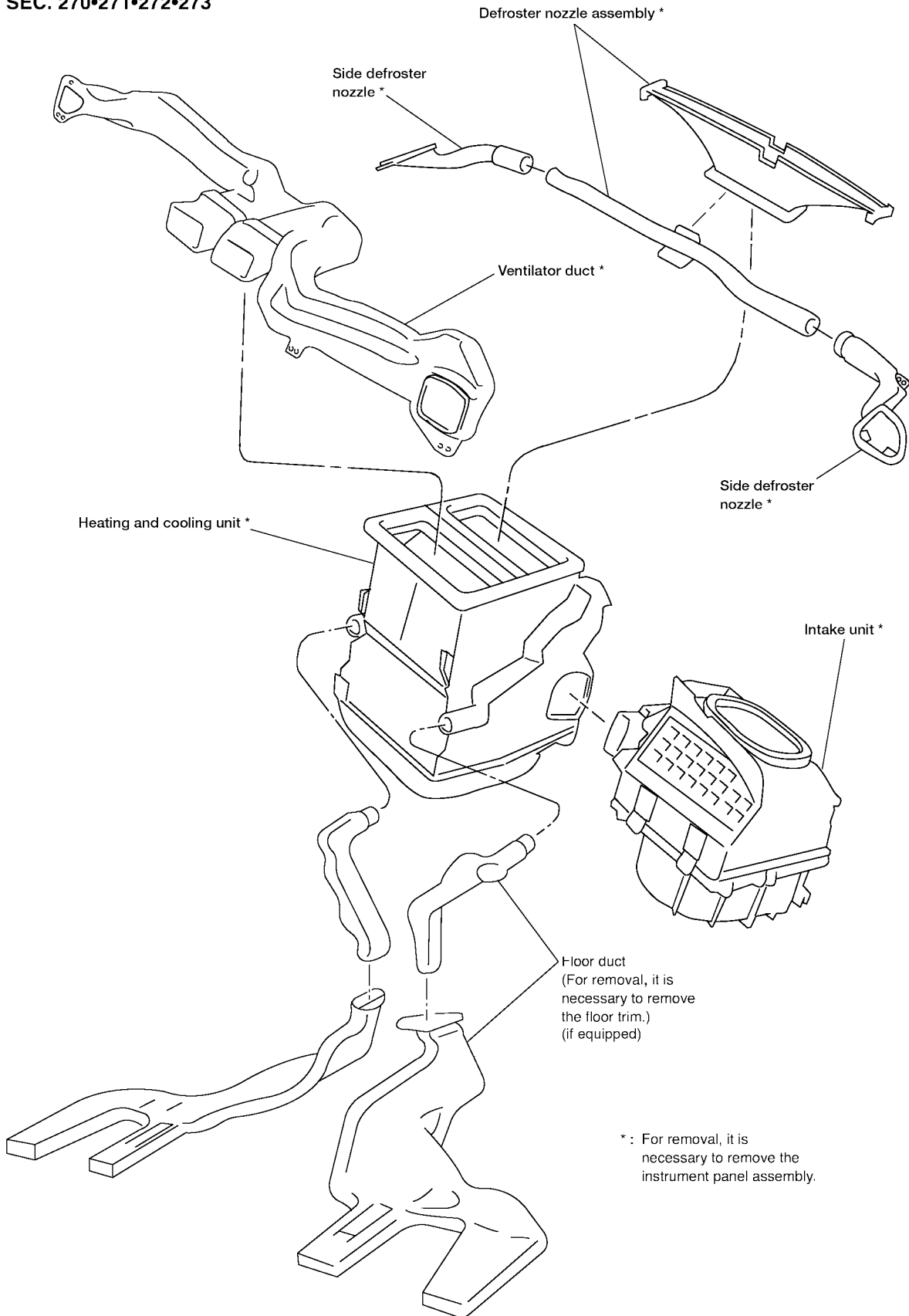

A
B
C
D
E
F
G
H
I
K
L
M

MTC

TROUBLE DIAGNOSIS

Control Operation

EJS001AL

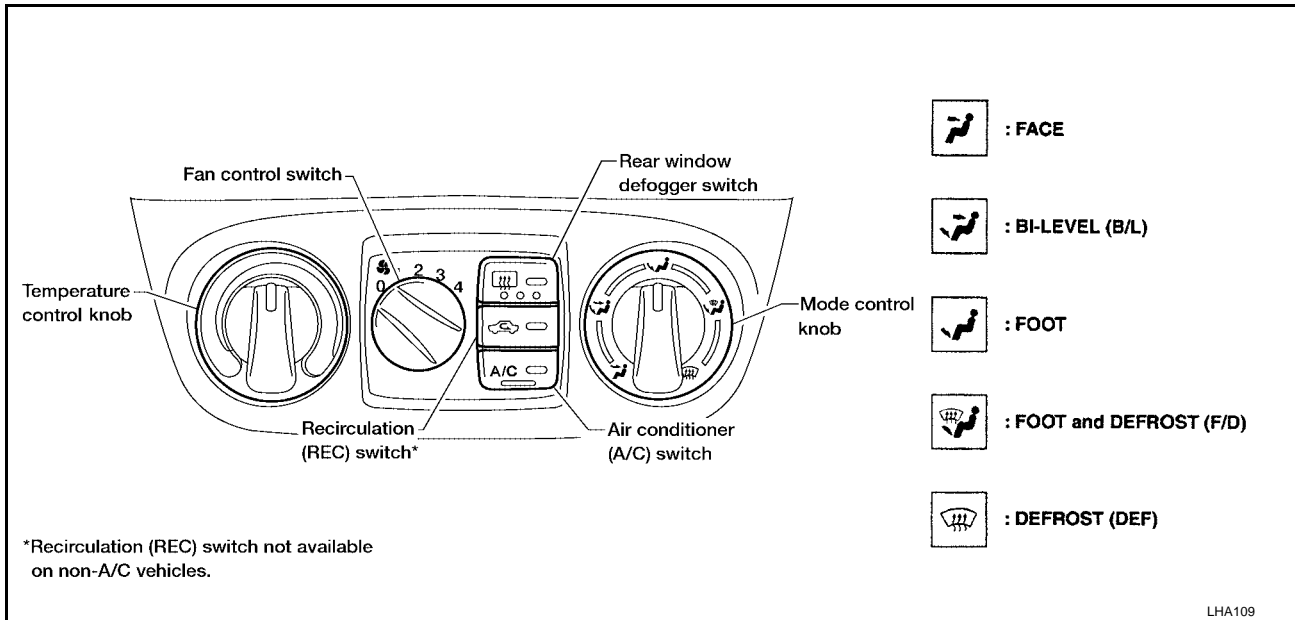

FAN CONTROL SWITCH

This switch turns the fan ON and OFF, and controls fan speed.

REAR WINDOW DEFOGGER SWITCH

This switch turns the rear window defogger ON and OFF.

MODE CONTROL KNOB

This control knob controls the outlet air flow.

When DEF or F/D mode is selected, the push control unit sets the intake door to FRESH.

The compressor turns on when DEF mode is selected and remains on until the key is turned off.

TEMPERATURE CONTROL KNOB

This knob adjusts the temperature of the discharge air.

RECIRCULATION (REC) SWITCH

OFF position: Outside air is drawn into the passenger compartment.

ON position: Interior air is recirculated inside the vehicle.

The indicator lamp will also light.

Recirculation is canceled when DEF or F/D mode is selected, and resumes when another mode is chosen.

AIR CONDITIONER (A/C) SWITCH

The air conditioner switch controls the A/C system. When the switch is depressed with the fan ON, the compressor will turn ON. The indicator lamp will also light.

The air conditioner cooling function operates only when the engine is running.

TROUBLE DIAGNOSIS

Discharge Air Flow

EJS001AM

A
B
C
D
E
F
G
H
I
MTC
K
L
M

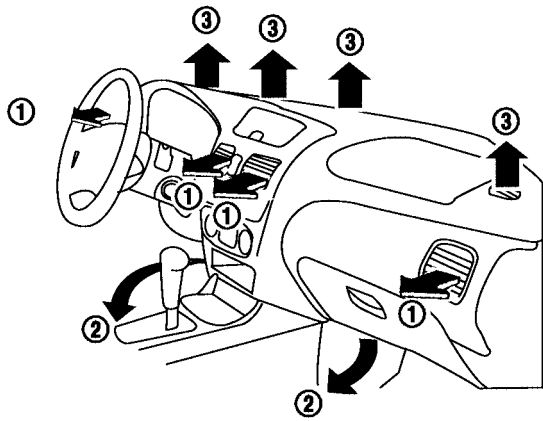

Foot

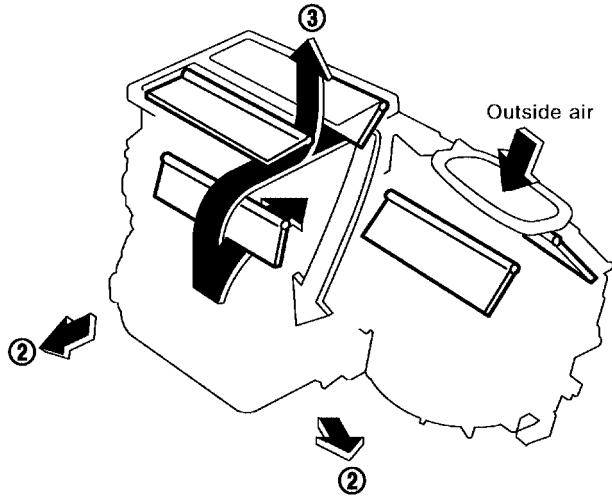

Ventilation

(Recirculation  position)

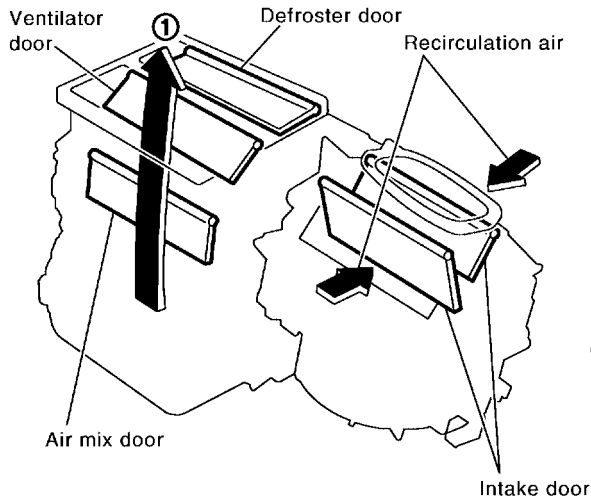

F/D

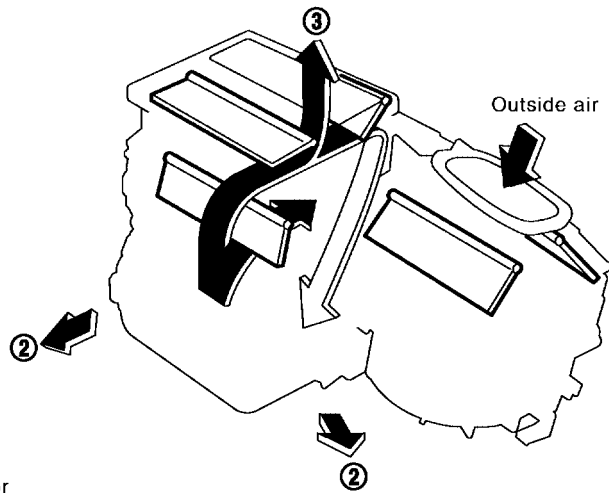

Bi-level

(Fresh  position)

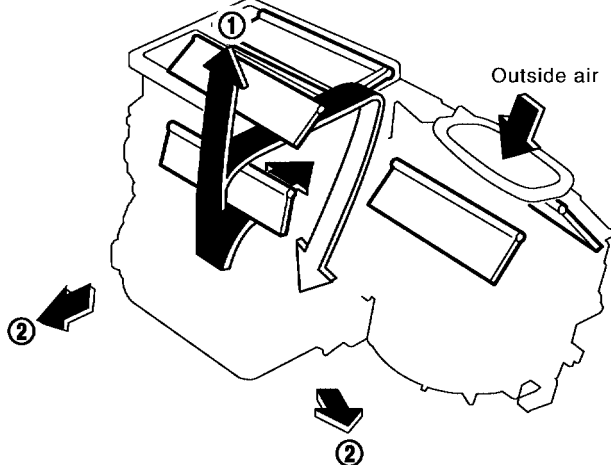

Defroster

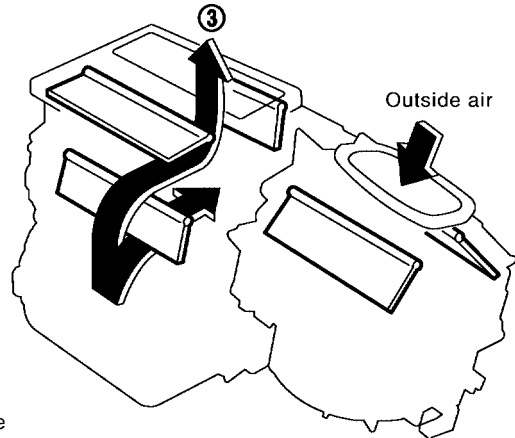

- ①: To face
- ②: To foot
- ③: To defroster













For air flow %, refer to "Operational Check", "TROUBLE DIAGNOSES".

LHA127

TROUBLE DIAGNOSIS

System Description SWITCHES AND THEIR CONTROL FUNCTIONS

EJS001AN

Knob/Switch	Knob/Switch position							Air outlet	Intake air	Compressor
	A/C									
A/C	○							—	—	ON*1
Mode			○					FACE	—	—
				○				B/L	—	—
					○			FOOT	—	—
						○		F/D	FRE	—
							○	DEF	FRE	ON*1
							○	—	REC*2	—

*1: Compressor operation is controlled by the ECM (when the compressor is activated in DEF mode, it remains on until the key is turned off).

*2: In DEF and F/D modes, REC switch is canceled.

TROUBLE DIAGNOSIS

Component Location ENGINE COMPARTMENT

EJS001AO

A
B
C
D
E
F
G
H
I
MTC
K
L
M

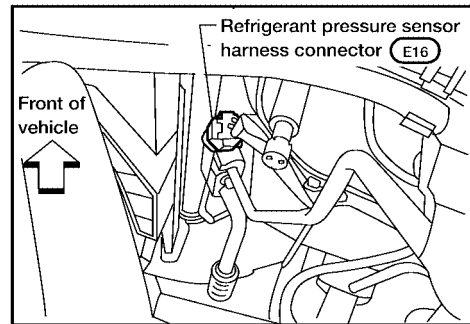
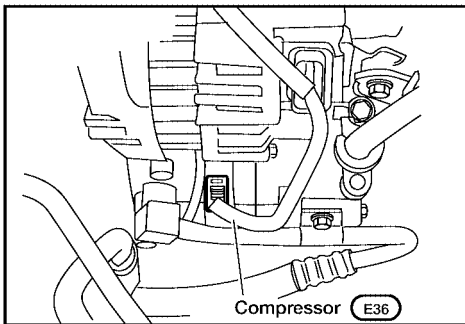
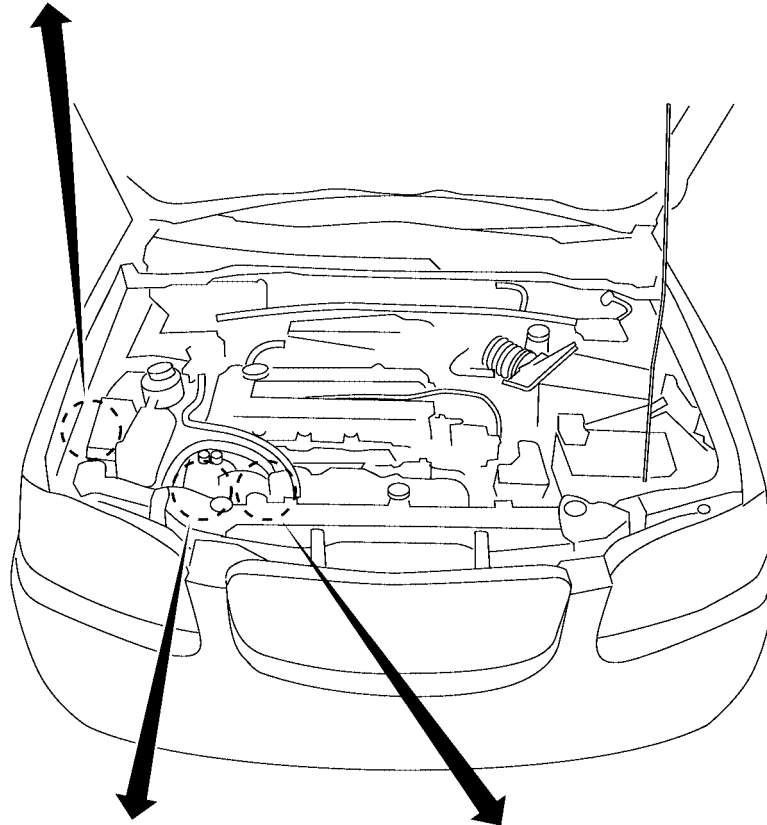
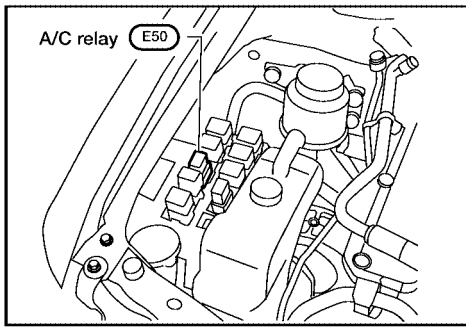

WJIA0248E

TROUBLE DIAGNOSIS

PASSENGER COMPARTMENT

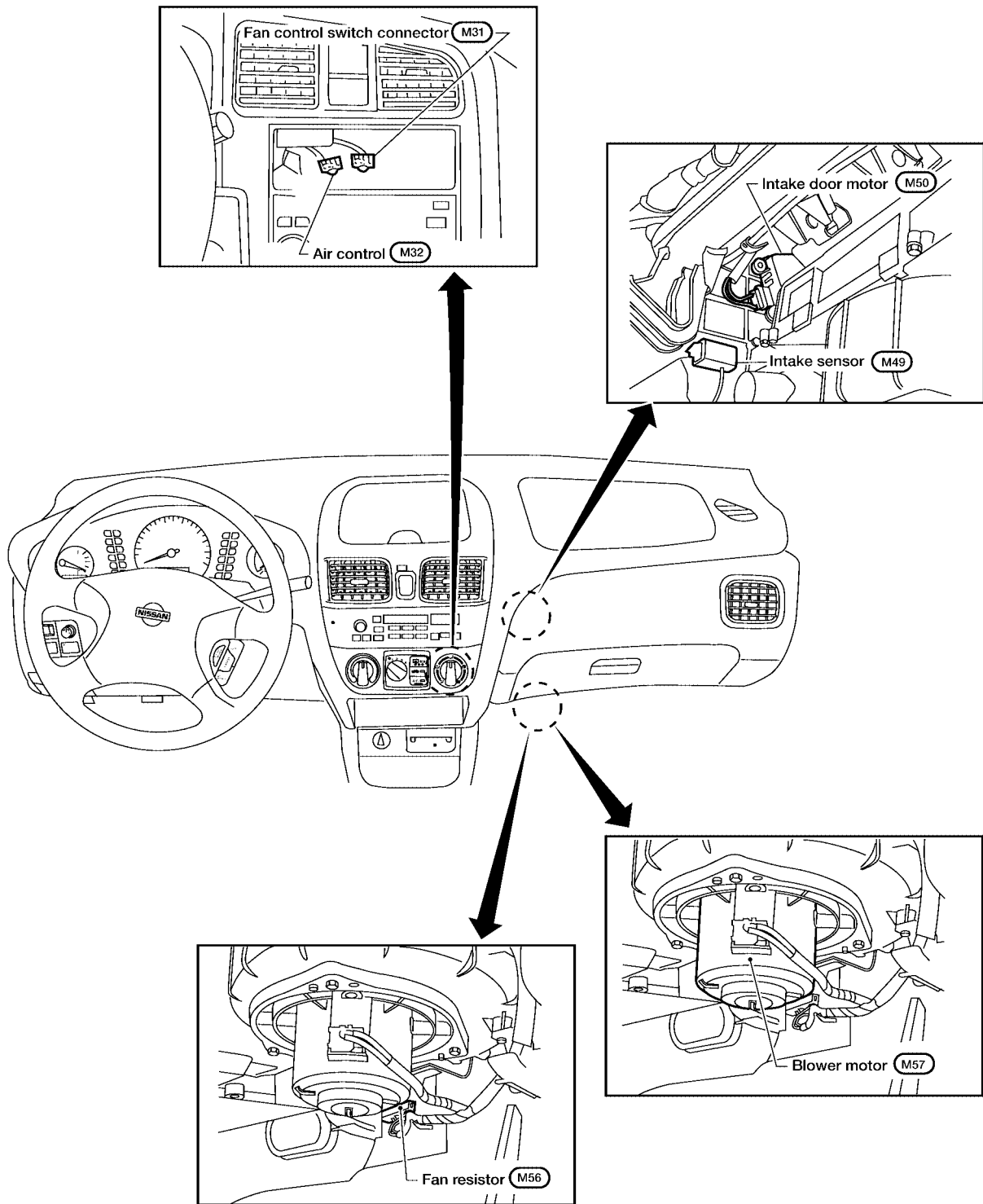

TROUBLE DIAGNOSIS

Wiring Diagram — Heater — QG18DE MODELS

EJS001AP

MTC-HEATER-01

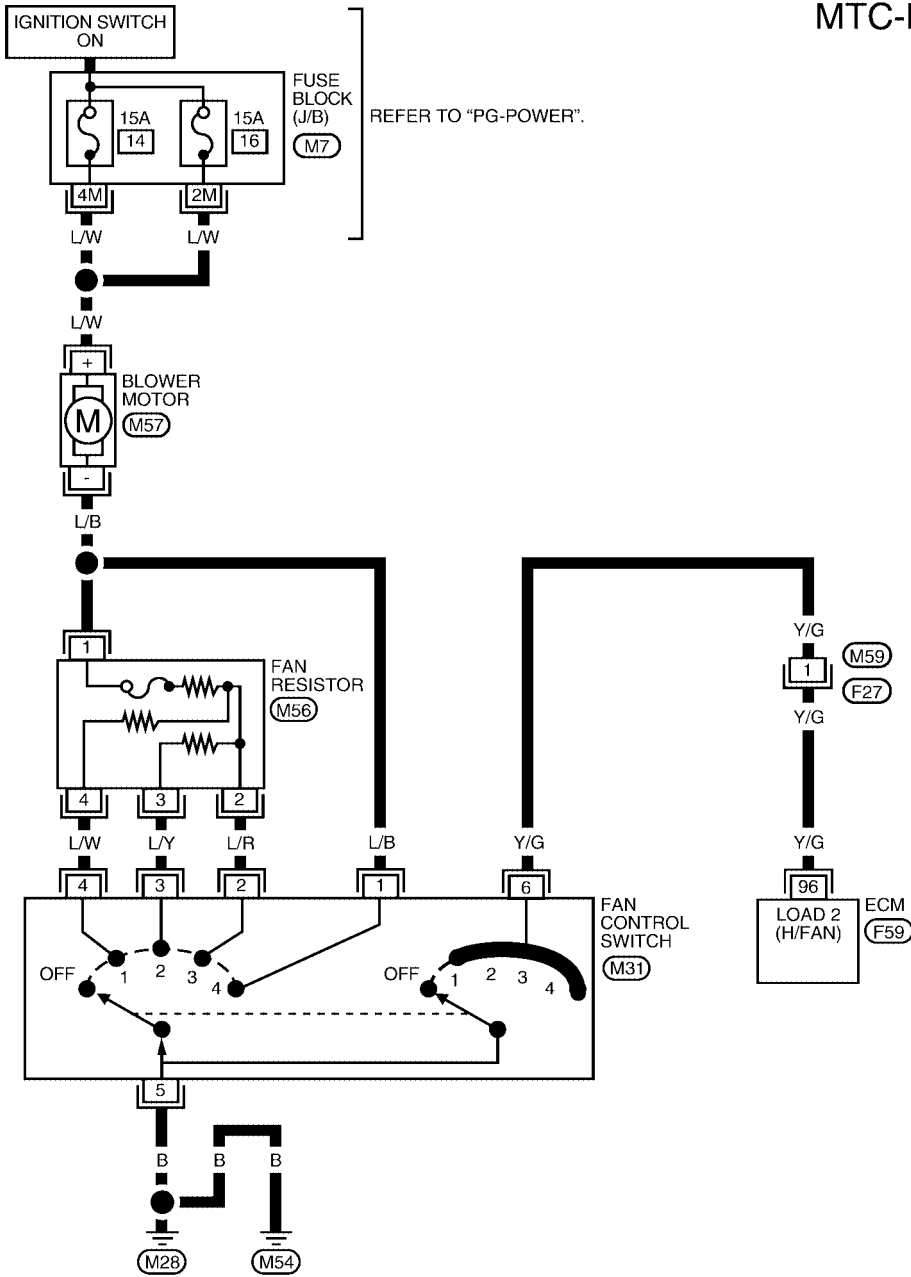

A
B
C
D
E
F
G
H
I
MTC
K
L
M

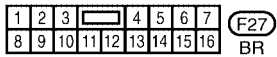
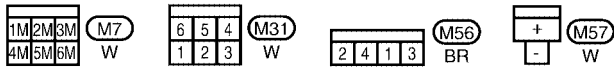

REFER TO THE FOLLOWING.
(F59) - ELECTRICAL UNITS

TROUBLE DIAGNOSIS

ECM TERMINALS AND REFERENCE VALUE MEASURED BETWEEN EACH TERMINAL AND GROUND				
TERMINAL	WIRE COLOR	ITEM	CONDITION	DATA (DC)
96	Y/G	FAN CONTROL SWITCH	FAN CONTROL SWITCH "ON" (ENGINE RUNNING)	APPROX. 0V
			FAN CONTROL SWITCH "OFF" (ENGINE RUNNING)	APPROX. 5V

TROUBLE DIAGNOSIS

EJS001AQ

Wiring Diagram — A/C, M — QG18DE MODELS

MTC-A/C,M-01

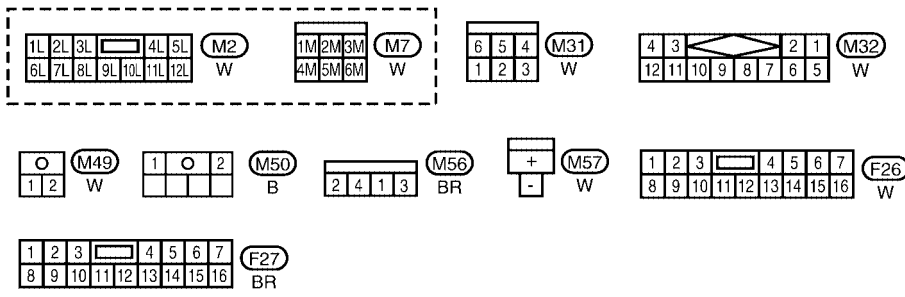
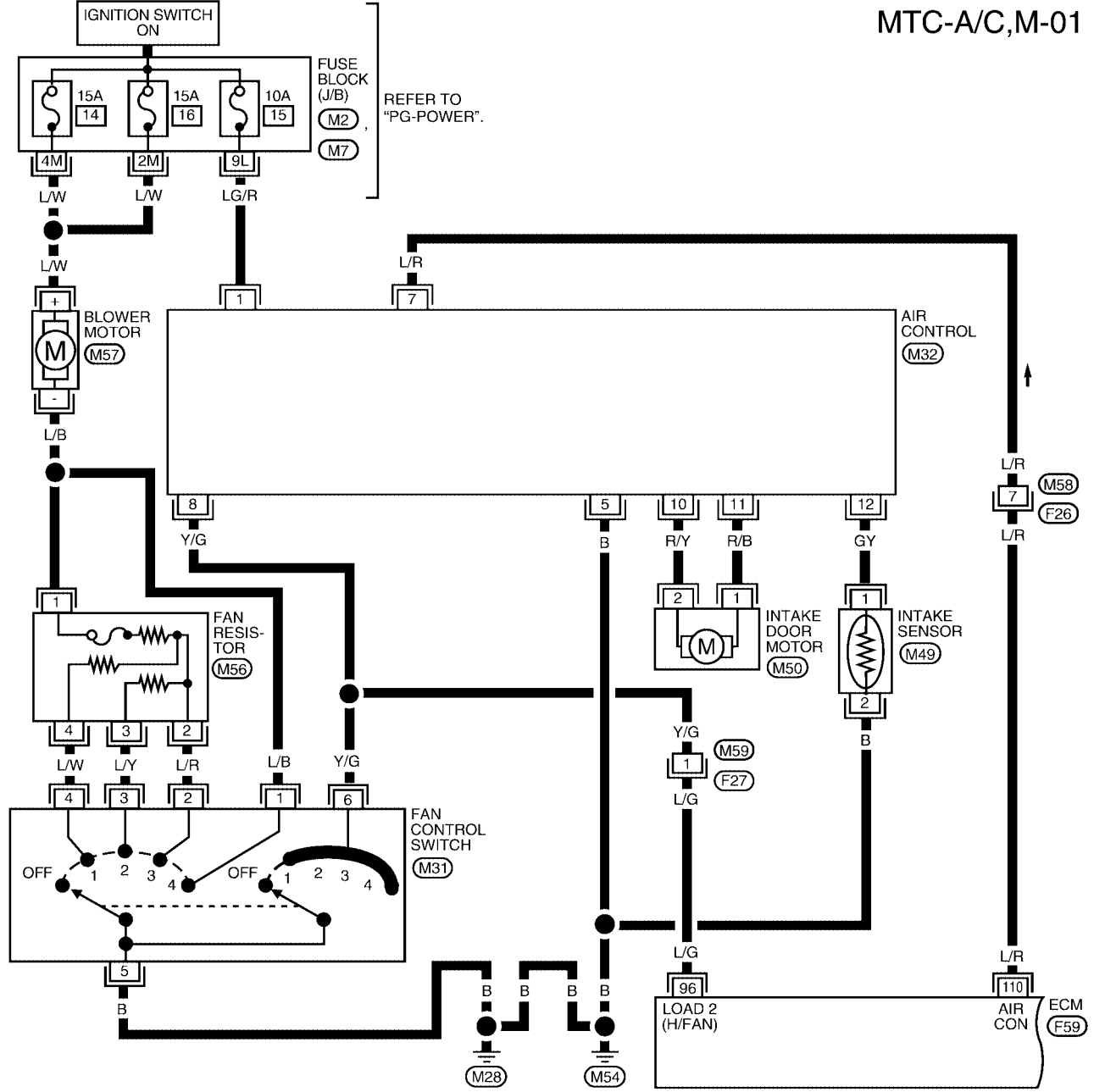

REFER TO THE FOLLOWING.
F59 - ELECTRICAL UNITS

A
B
C
D
E
F
G
H
I
MTC
K
L
M

TROUBLE DIAGNOSIS

ECM TERMINALS AND REFERENCE VALUE MEASURED BETWEEN EACH TERMINAL AND GROUND

TERMINAL	WIRE COLOR	ITEM	CONDITION	DATA (DC)
96	Y/G	FAN CONTROL SWITCH	FAN CONTROL SWITCH "ON" (ENGINE RUNNING)	APPROX. 0V
			FAN CONTROL SWITCH "OFF" (ENGINE RUNNING)	APPROX. 5V
110	L/R	AIR CONDITIONER SWITCH SIGNAL	BOTH A/C SWITCH AND BLOWER SWITCH "ON" (ENGINE RUNNING)	APPROX. 0V
			A/C SWITCH "OFF" (ENGINE RUNNING)	BATTERY VOLTAGE

TROUBLE DIAGNOSIS

MTC-A/C,M-02

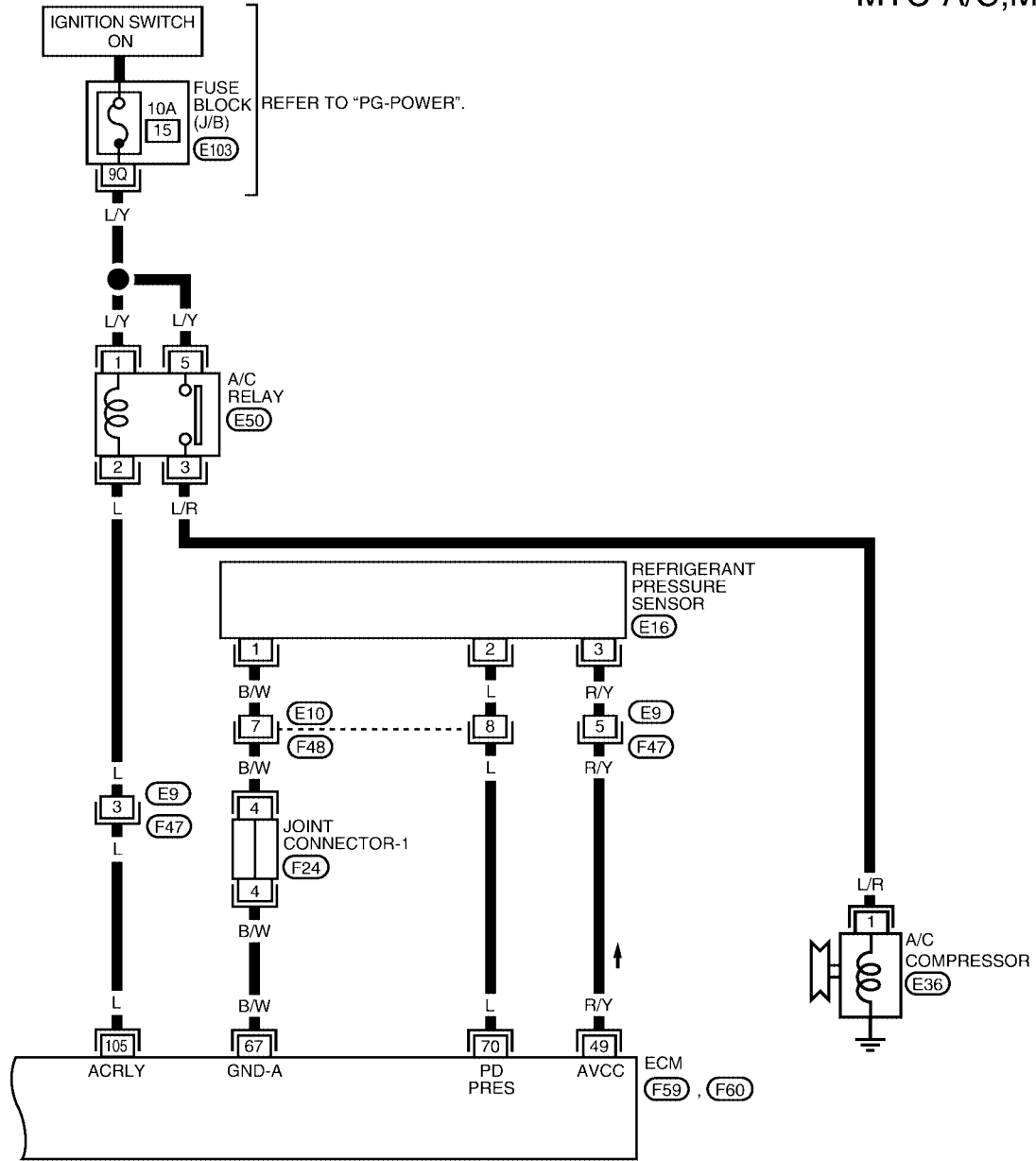

A
B
C
D
E
F
G
H
I
MTC
K
L
M

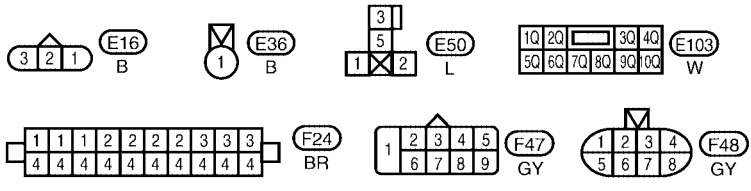

REFER TO THE FOLLOWING.
 (F59), (F60) - ELECTRICAL UNITS

TROUBLE DIAGNOSIS

ECM TERMINALS AND REFERENCE VALUE MEASURED BETWEEN EACH TERMINAL AND GROUND

TERMINAL	WIRE COLOR	ITEM	CONDITION	DATA (DC)
49	R/L	SENSOR POWER SUPPLY	IGNITION SWITCH "ON"	APPROX. 5.0V
67	B/W	ECM GROUND	IDLE SPEED (ENGINE RUNNING)	1V OR LESS
70	L	REFRIGERANT PRESSURE SENSOR	BOTH A/C SWITCH AND BLOWER SWITCH "ON" (ENGINE RUNNING, WARM-UP CONDITION, COMPRESSOR OPERATING)	0.36 - 3.88V
105	L	AIR CONDITIONER RELAY	BOTH A/C SWITCH AND BLOWER SWITCH "ON" (ENGINE RUNNING) (COMPRESSOR OPERATING)	0 - 1.0V
			A/C SWITCH "OFF" (ENGINE RUNNING)	BATTERY VOLTAGE

TROUBLE DIAGNOSIS

QR25DE MODELS

MTC-A/C, M-03

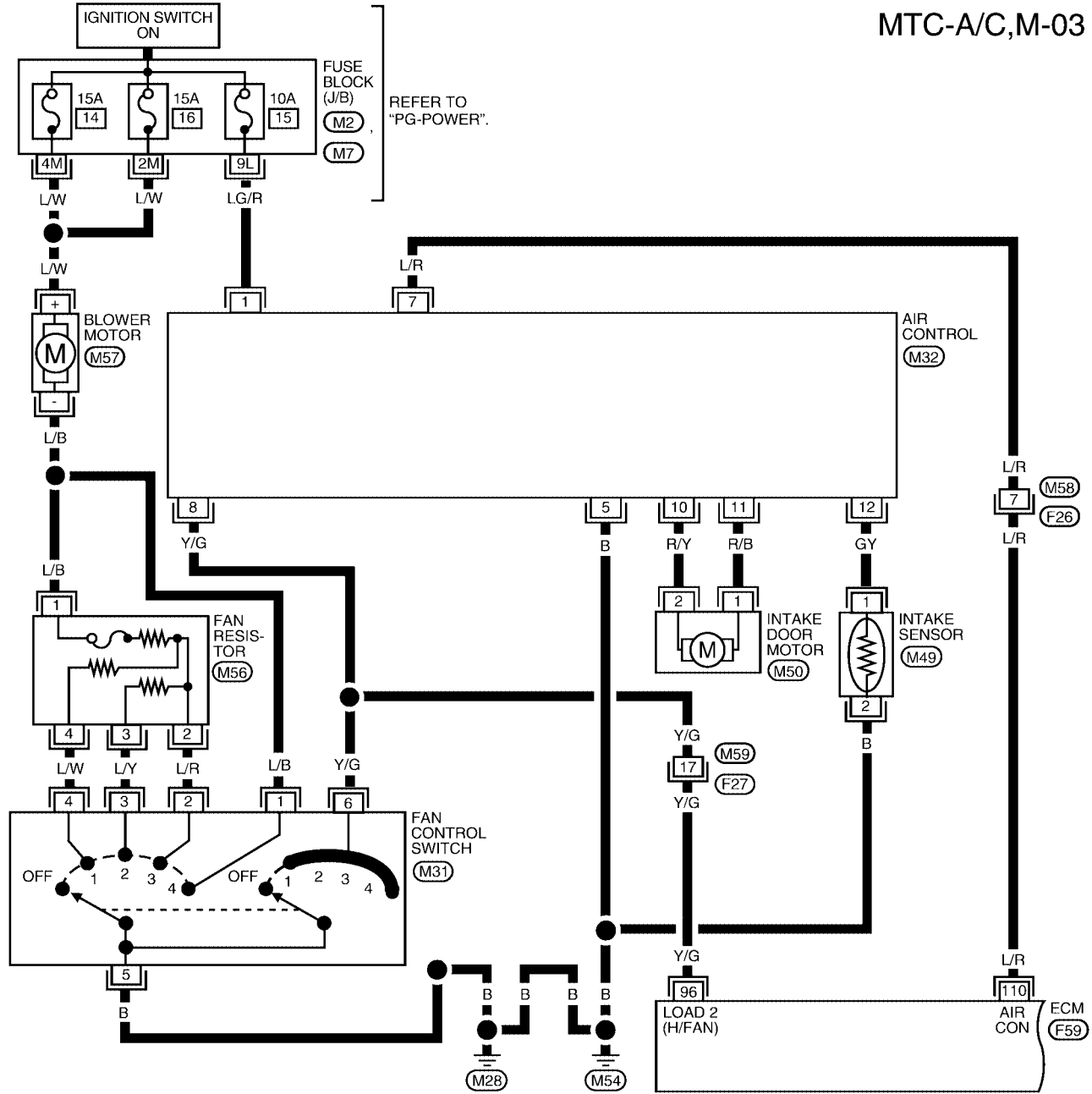

A
B
C
D
E
F
G
H
I
MTC
K
L
M

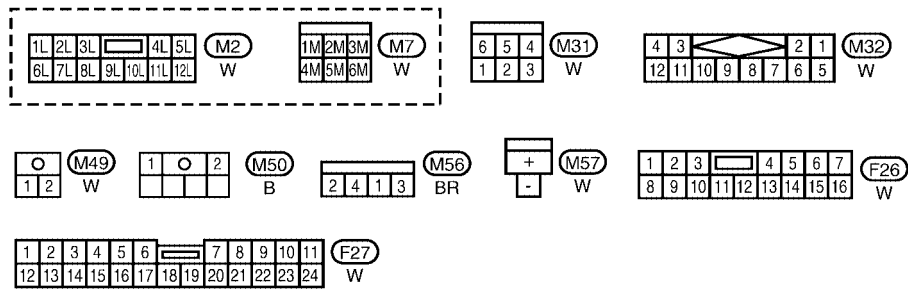

REFER TO THE FOLLOWING.
 (F59) - ELECTRICAL UNITS

TROUBLE DIAGNOSIS

ECM TERMINALS AND REFERENCE VALUE MEASURED BETWEEN EACH TERMINAL AND GROUND

TERMINAL	WIRE COLOR	ITEM	CONDITION	DATA (DC)
96	Y/G	FAN CONTROL SWITCH	FAN CONTROL SWITCH "ON" (ENGINE RUNNING)	APPROX. 0V
			FAN CONTROL SWITCH "OFF" (ENGINE RUNNING)	APPROX. 5V
110	L/R	AIR CONDITIONER SWITCH SIGNAL	BOTH A/C SWITCH AND BLOWER SWITCH "ON" (ENGINE RUNNING)	APPROX. 0V
			A/C SWITCH "OFF" (ENGINE RUNNING)	BATTERY VOLTAGE

TROUBLE DIAGNOSIS

MTC-A/C,M-04

A
B
C
D
E
F
G
H
I
MTC
K
L
M

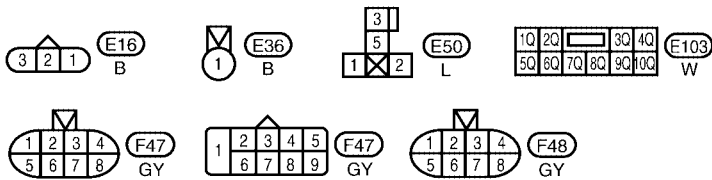
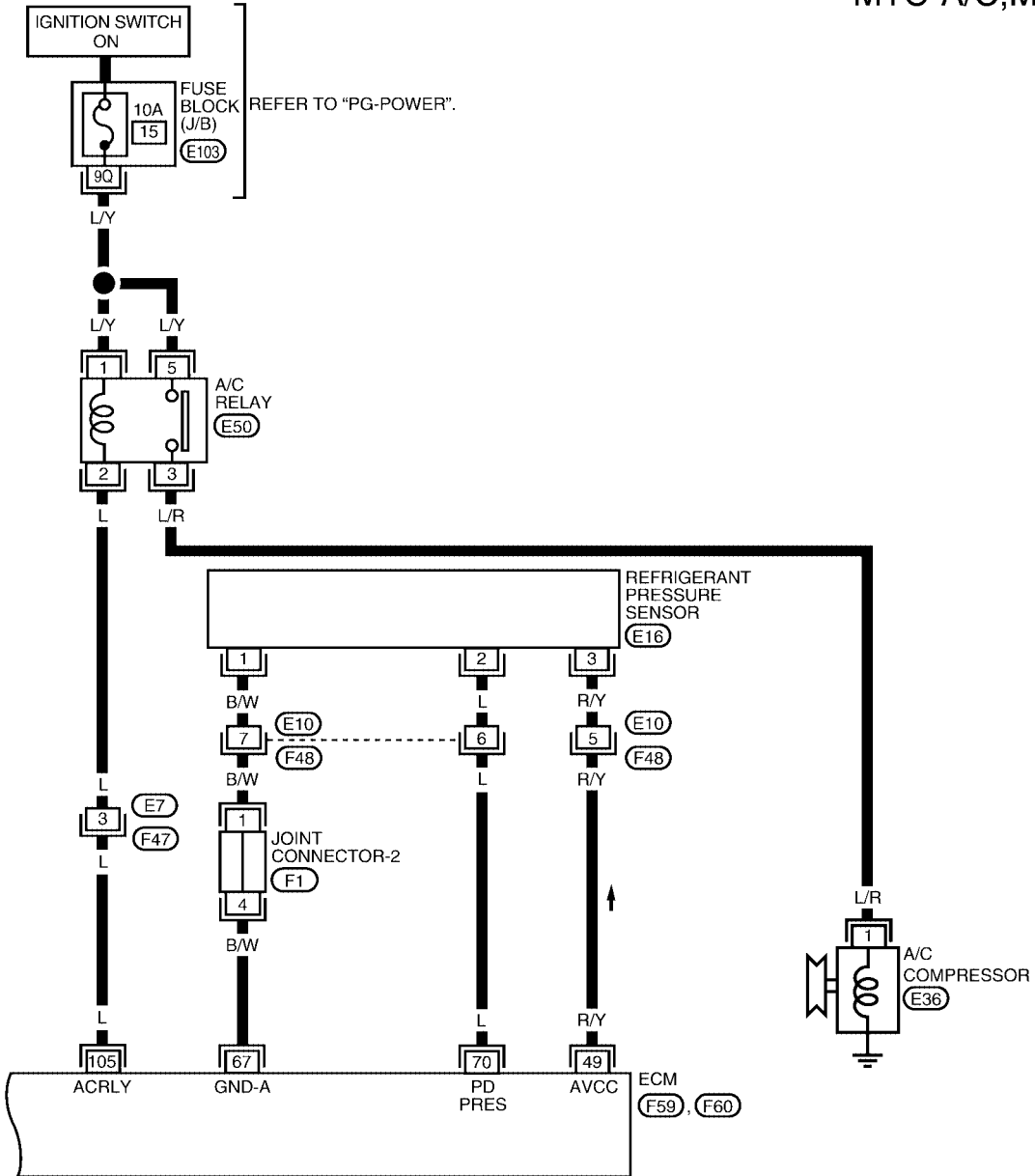

REFER TO THE FOLLOWING.
 (F1) - JOINT CONNECTOR
 (F59), (F60) - ELECTRICAL UNITS

WJWA0056E

TROUBLE DIAGNOSIS

ECM TERMINALS AND REFERENCE VALUE MEASURED BETWEEN EACH TERMINAL AND GROUND

TERMINAL	WIRE COLOR	ITEM	CONDITION	DATA (DC)
49	R/Y	SENSOR POWER SUPPLY	IGNITION SWITCH "ON"	APPROX. 5.0V
58	B/W	ECM GROUND	IDLE SPEED (ENGINE RUNNING)	1V OR LESS
70	L	REFRIGERANT PRESSURE SENSOR	BOTH A/C SWITCH AND BLOWER SWITCH "ON" (ENGINE RUNNING, WARM-UP CONDITION, COMPRESSOR OPERATING)	0.36 - 3.88V
105	L	AIR CONDITIONER RELAY	BOTH A/C SWITCH AND BLOWER SWITCH "ON" (ENGINE RUNNING) (COMPRESSOR OPERATING)	0 - 1.0V
			A/C SWITCH "OFF" (ENGINE RUNNING)	BATTERY VOLTAGE

How to Perform Trouble Diagnoses for Quick and Accurate Repair

EJS001AR

WORK FLOW

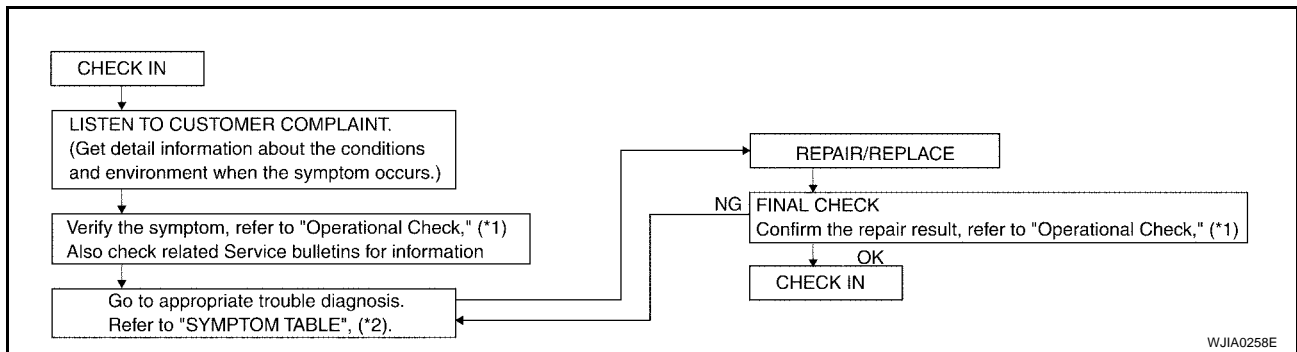

WJIA0258E

*1: [MTC-35](#)

*2: [MTC-34](#)

SYMPTOM TABLE

Symptom	Reference page
● Intake door does not change in VENT, B/L or FOOT mode.	● Go to "TROUBLE DIAGNOSIS PROCEDURE FOR INTAKE DOOR". MTC-38
● Air outlet does not change.	● Go to "TROUBLE DIAGNOSIS PROCEDURE FOR MODE DOOR". MTC-42
● Air mix door does not change.	● Go to "TROUBLE DIAGNOSIS PROCEDURE FOR AIR MIX DOOR". MTC-44
● Blower motor does not rotate at all.	● Go to "TROUBLE DIAGNOSIS PROCEDURE FOR BLOWER MOTOR". MTC-46
● Magnet clutch does not engage when A/C switch and fan switch are ON.	● Go to "TROUBLE DIAGNOSIS PROCEDURE FOR MAGNET CLUTCH". MTC-51
● Insufficient cooling.	● Go to "TROUBLE DIAGNOSIS PROCEDURE FOR INSUFFICIENT COOLING". MTC-57
● Insufficient heating.	● Go to "TROUBLE DIAGNOSIS PROCEDURE FOR INSUFFICIENT HEATING". MTC-64
● Noise	● Go to "TROUBLE DIAGNOSIS PROCEDURE FOR NOISE". MTC-65

TROUBLE DIAGNOSIS

EJS001AS

Operational Check

The purpose of the operational check is to confirm that the system operates properly.

CONDITIONS:

- Engine running and at normal operating temperature.

PROCEDURE:

1. Check Blower

1. Turn fan control switch to 1-speed.
Blower should operate on 1-speed.
2. Then turn fan control switch to 2-speed, and continue checking blower speed until all speeds are checked.
3. Leave fan control switch on 4-speed.

If NG, go to [MTC-46, "Trouble Diagnosis Procedure for Blower Motor"](#).

If OK, continue with next check.

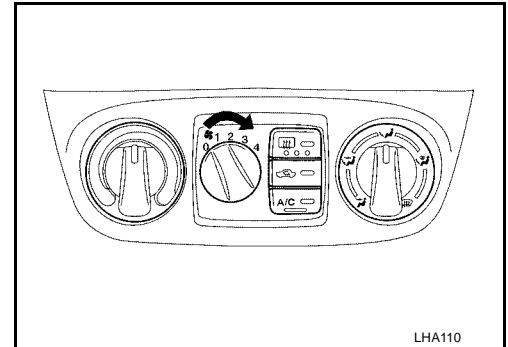

2. Check Discharge Air

1. Turn knob to each mode.

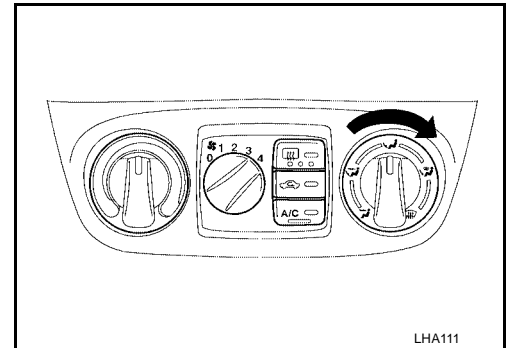

2. Confirm that discharge air comes out according to the air distribution table.

Refer to [MTC-21, "Discharge Air Flow"](#).

If NG, go to [MTC-42, "TROUBLE DIAGNOSIS PROCEDURE FOR MODE DOOR"](#).

If OK, continue with next check.





NOTE:

Confirm that the compressor clutch is engaged (visual inspection) and intake door position is at FRESH when the DEF  mode is selected.

Confirm that the intake door position is at FRESH when the F/D  mode is selected.

Intake door position is checked in the next step.

Discharge air flow

Mode control knob	Air outlet/distribution		
	Face	Foot	Defroster
	100%	–	–
	60%	40%	–
	–	80%	20%
	–	60%	40%
	–	–	100%

RHA654F

A
B
C
D
E
F
G
H
I

MTC

K
L
M

TROUBLE DIAGNOSIS

3. Check Recirculation

1. Press REC  switch.
Recirculation indicator should illuminate.
2. Listen for intake door position change (you should hear blower sound change slightly).

If NG, go to [MTC-38, "Trouble Diagnosis Procedure for Intake Door"](#) .
If OK, continue with next check.

NOTE:

- Recirculation does not operate in DEF  and F/D  modes.

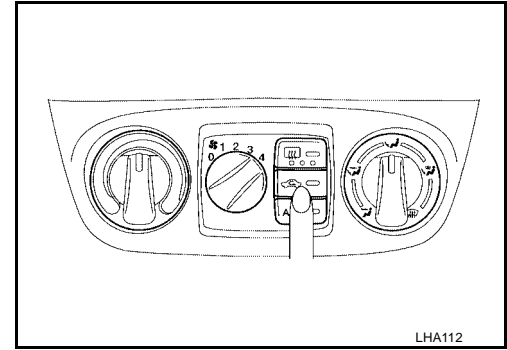

4. Check Temperature Decrease

1. Turn temperature control knob to full cold.
2. Check for cold air at discharge air outlets.

If NG, go to [MTC-57, "Trouble Diagnosis Procedure for Insufficient Cooling"](#) .

If OK, continue with next check.

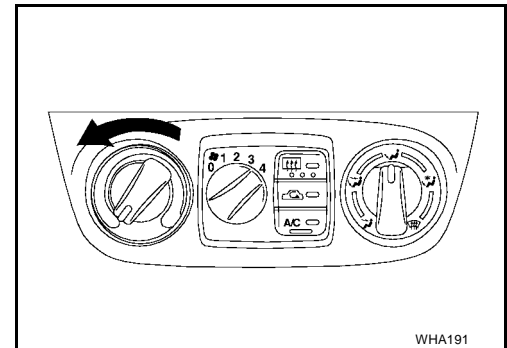

5. Check Temperature Increase

1. Turn temperature control knob to full hot.
2. Check for hot air at discharge air outlets.

If NG, go to [MTC-64, "Trouble Diagnosis Procedure for Insufficient Heating"](#) .

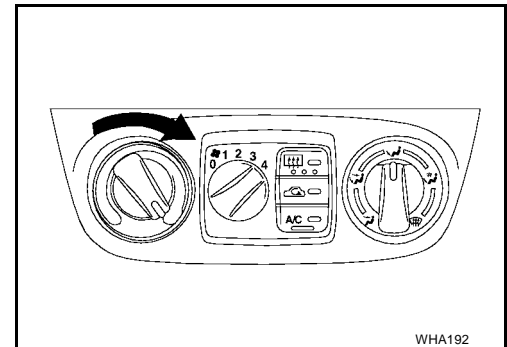

6. Check Air Conditioner Switch

Turn the fan control switch to the desired (1- to 4-speed) position and push the A/C switch to turn ON the air conditioner.

The indicator lamp should come on when air conditioner is ON.

If NG, go to [MTC-51, "Trouble Diagnosis Procedure for Magnet Clutch"](#) .

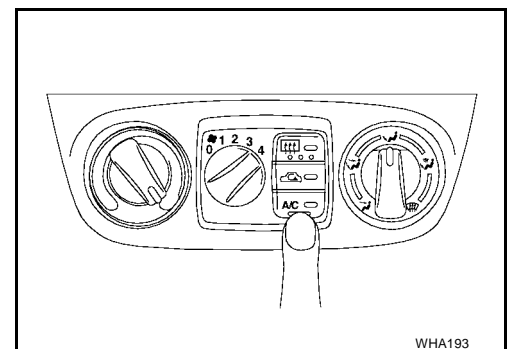

TROUBLE DIAGNOSIS

Main Power Supply and Ground Circuit Check POWER SUPPLY CIRCUIT CHECK

EJS001AT

Check power supply circuit for air conditioner system.
Refer to [PG-5, "Wiring Diagram — POWER —"](#) .

A

B

C

D

E

F

G

H

I

MTC

K

L

M

INTAKE DOOR

PF2:27245

EJS001AU

INTAKE DOOR

Trouble Diagnosis Procedure for Intake Door

SYMPTOM:

- Intake door does not change.

INSPECTION FLOW

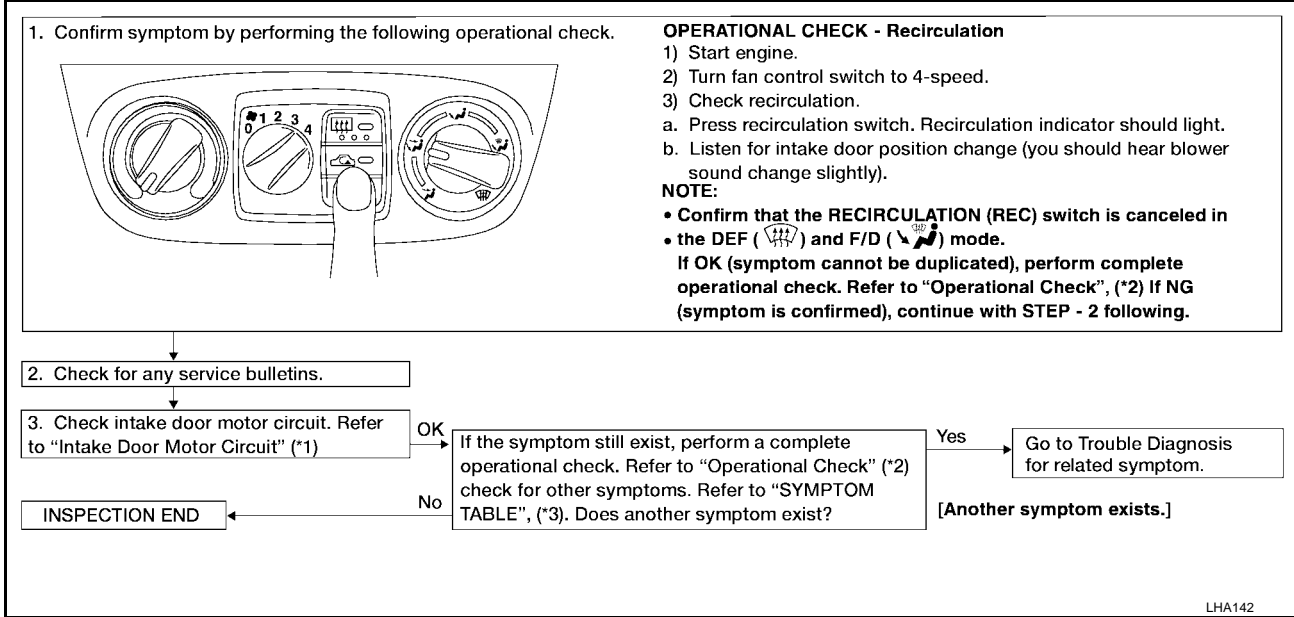

*1 [MTC-39](#)

*2 [MTC-35](#)

*3 [MTC-34](#)

Component Description INTAKE DOOR MOTOR

EJS001AV

The intake door motor is installed on the intake unit. Using a link, it opens and closes the intake door.

When REC switch is ON, the ground line of the motor is switched from terminal 2 to 1. This starts the motor because the position switch contacts built into it make current flow. When REC switch is OFF, the ground line is switched from terminal 1 to 2. The contacts turn along with the motor. When they reach the non-current flow position, the motor will stop.

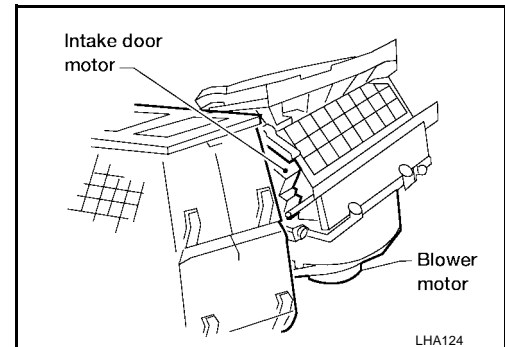

INTAKE DOOR

Intake Door Motor Circuit

EJS001AW

SYMPTOM:

- Intake door does not change.

1. CHECK POWER SUPPLY FOR INTAKE DOOR MOTOR

Disconnect intake door motor harness connector.

Do approx. 12 volts exist between intake door motor harness terminal Nos. 1, 2 and body ground?

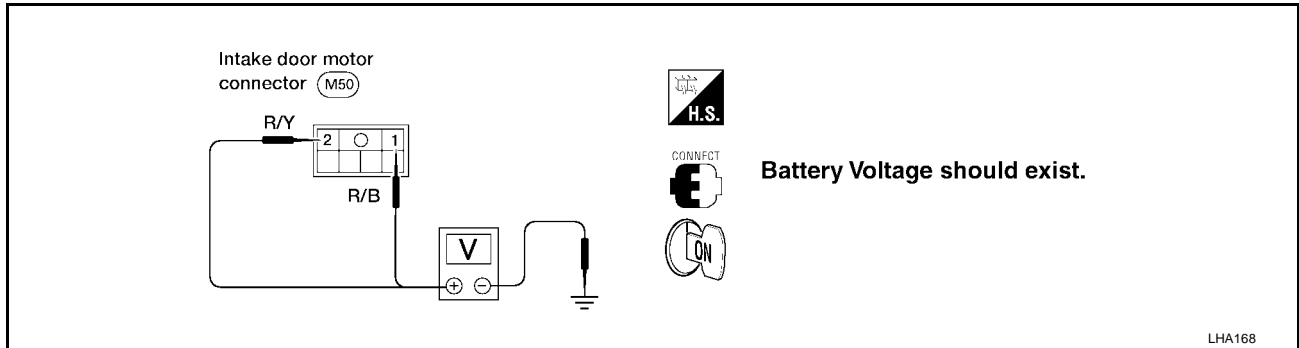

Yes or No

Yes >> GO TO 3.

No >> GO TO 2.

A

B

C

D

E

F

G

H

I

MTC

K

L

M

INTAKE DOOR

2. CHECK CIRCUIT CONTINUITY BETWEEN INTAKE DOOR MOTOR AND AIR CONTROL UNIT

Check circuit continuity between A/C control unit harness terminal Nos. 10 (11) and intake door motor harness terminal Nos. 2 (1).

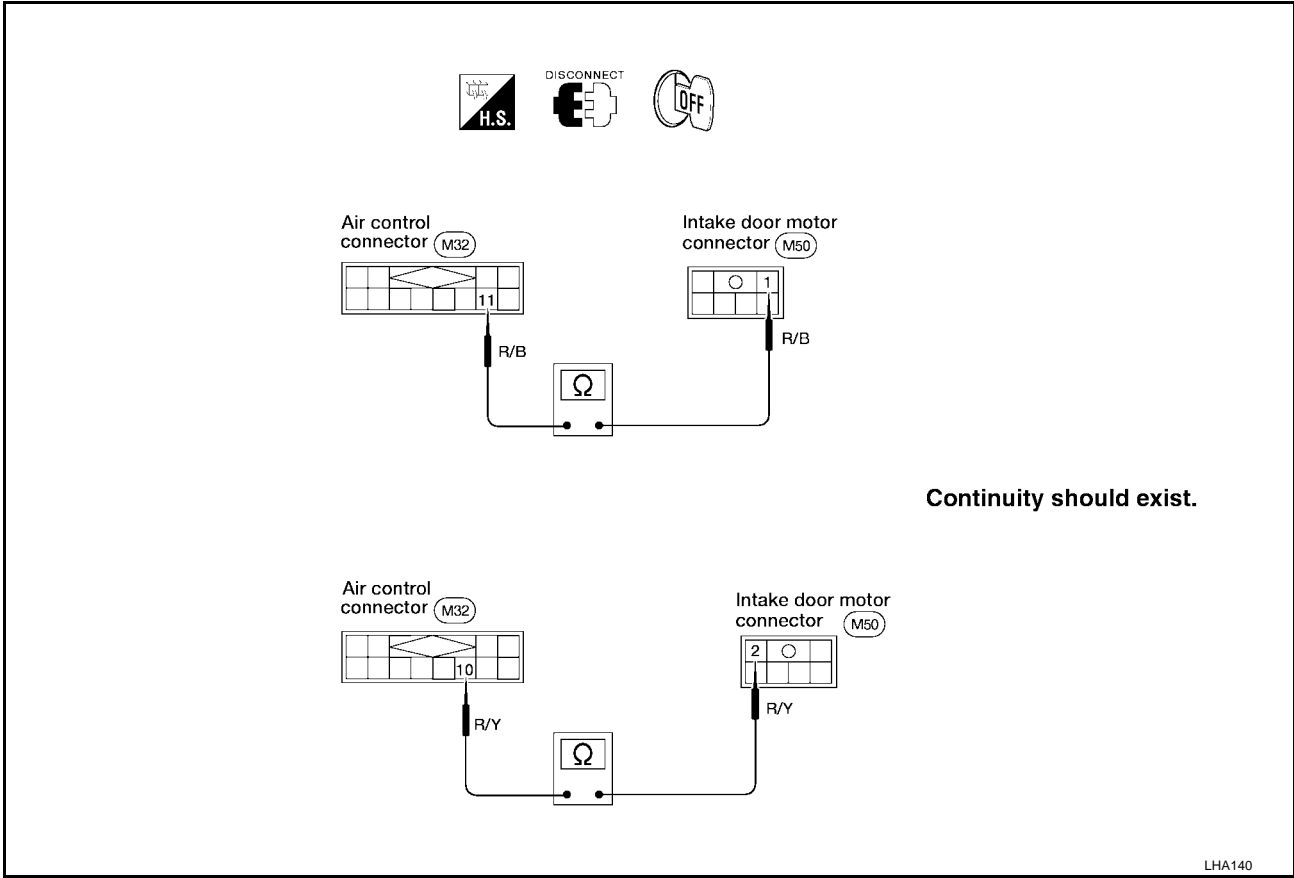

If OK, check harness for short.

Yes or No

- Yes >> Replace A/C control unit.
- No >> Repair harness or connector.

3. CHECK CIRCUIT CONTINUITY OF INTAKE DOOR MOTOR

Check circuit continuity between intake door motor harness terminal No. 1 and No. 2.

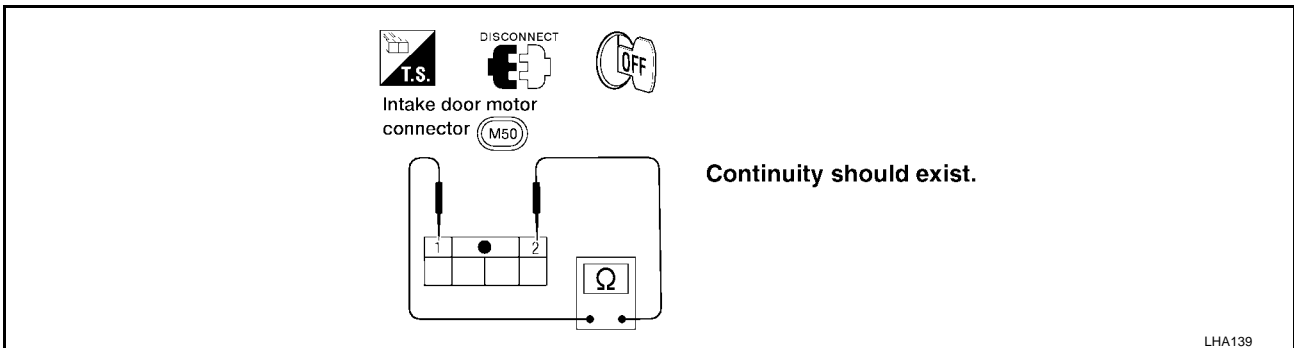

OK or NG

- OK >> GO TO 4.
- NG >> Replace intake door motor.

INTAKE DOOR

4. CHECK INTAKE DOOR LINKAGE

Refer to [MTC-43, "CONTROL LINKAGE ADJUSTMENT"](#) .

OK or NG

OK >> **INSPECTION END.**

NG >> Repair or adjust.

Control Linkage Adjustment INTAKE DOOR MOTOR

1. Install intake door motor on intake unit.
Ensure that the intake door motor lever is fitted into the slit portion of intake door link.
2. Connect the intake door motor harness connector.
3. Turn ignition switch to "ON" position.
4. Check that intake door operates properly when REC switch is turned ON and OFF.

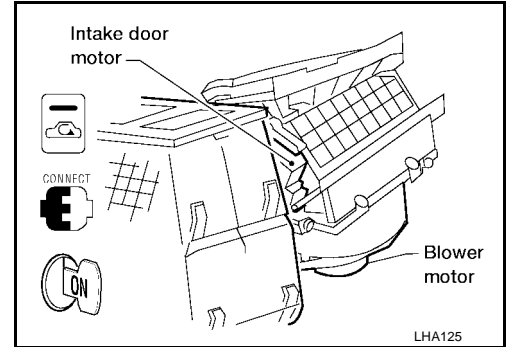

A
B
C
D
E
F
G
H
I
MTC
K
L
M

INTAKE DOOR

EJS001AY

Mode Door TROUBLE DIAGNOSIS PROCEDURE FOR MODE DOOR

SYMPTOM:

- Mode door does not change.

INSPECTION FLOW

1. Confirm symptom by performing the following operational check.

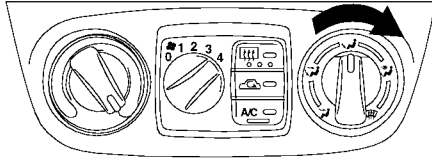

OPERATIONAL CHECK - Discharge air.

- 1) Turn mode control knob.
- 2) Confirm that discharge air comes out according to the air distribution table at left. Refer to "Discharge Air Flow" in "DESCRIPTION" (*1).

Discharge air flow

Mode control knob	Air outlet/distribution		
	Face	Foot	Defroster
	100%	-	-
	60%	40%	-
	-	80%	20%
	-	60%	40%
	-	-	100%

NOTE:

Confirm that the compressor clutch is engaged (visual inspection) and intake door position is at FRESH when the DEF () or D/F () button is pressed.

If OK (symptom cannot be duplicated), perform complete operational check (*3).

If NG (symptom is confirmed), continue with STEP-2 following.

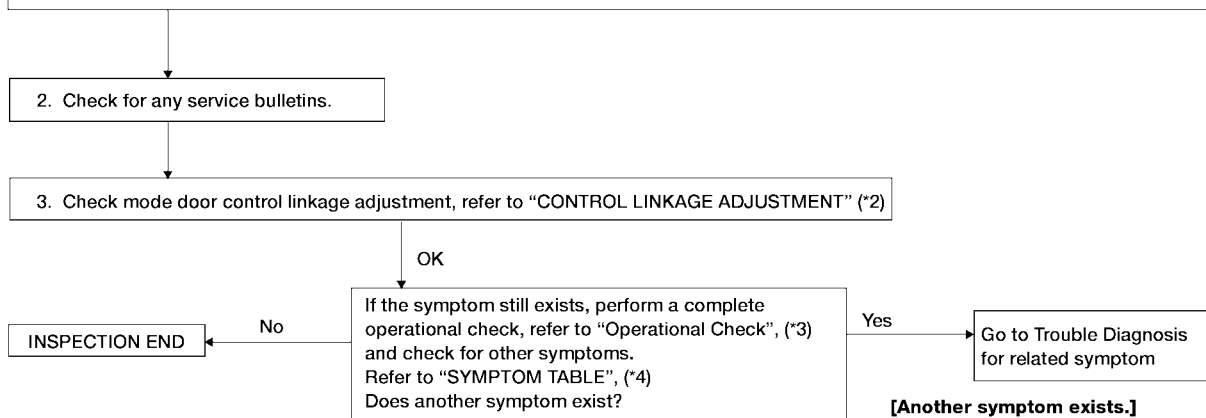

*1 [MTC-21](#)

*2 [MTC-41](#)

*3 [MTC-35](#)

*4 [MTC-34](#)

LHA146

INTAKE DOOR

CONTROL LINKAGE ADJUSTMENT

Mode Door Control Linkage

- Turn mode door control knob to  position.
- Set side link in DEF mode.
- Pull on outer cable in direction of arrow and then clamp it.
- **After positioning mode door control cable, check that it operates properly.**

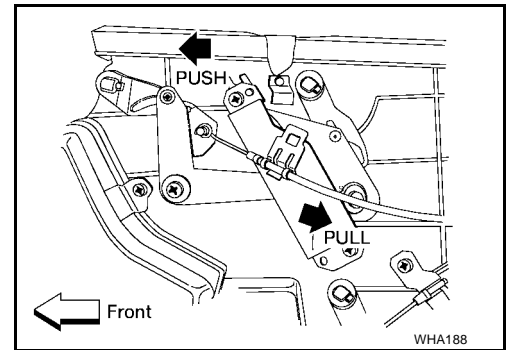

A

B

C

D

E

F

G

H

I

MTC

K

L

M

INTAKE DOOR

EJS001AZ

Air Mix Door

TROUBLE DIAGNOSIS PROCEDURE FOR AIR MIX DOOR

SYMPTOM:

- Air mix door does not change.

INSPECTION FLOW

1. Confirm symptom by performing the following operational check.

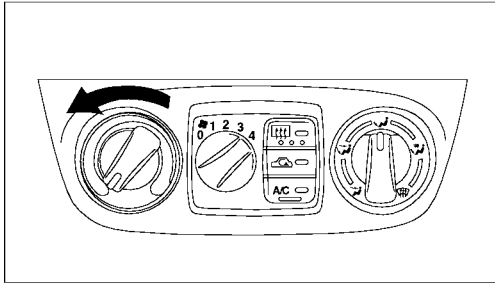

OPERATIONAL CHECK - Recirculation

1. Check Temperature Decrease
 - 1) Turn temperature control knob to full cold.
 - 2) Check for cold air at discharge air outlets.

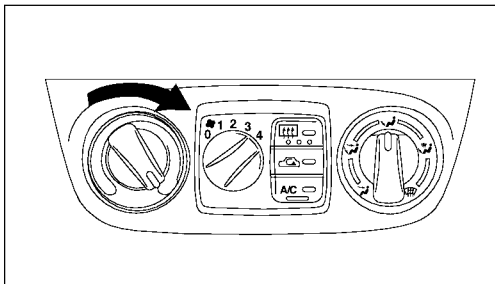

2. Check Temperature Increase
 - 1) Turn temperature control knob to full hot.
 - 2) Check for hot air at discharge air outlets.

If OK (symptom cannot be duplicated). Perform complete operational check. (*1)
If NG (symptom is confirmed), continue with STEP-2 following.

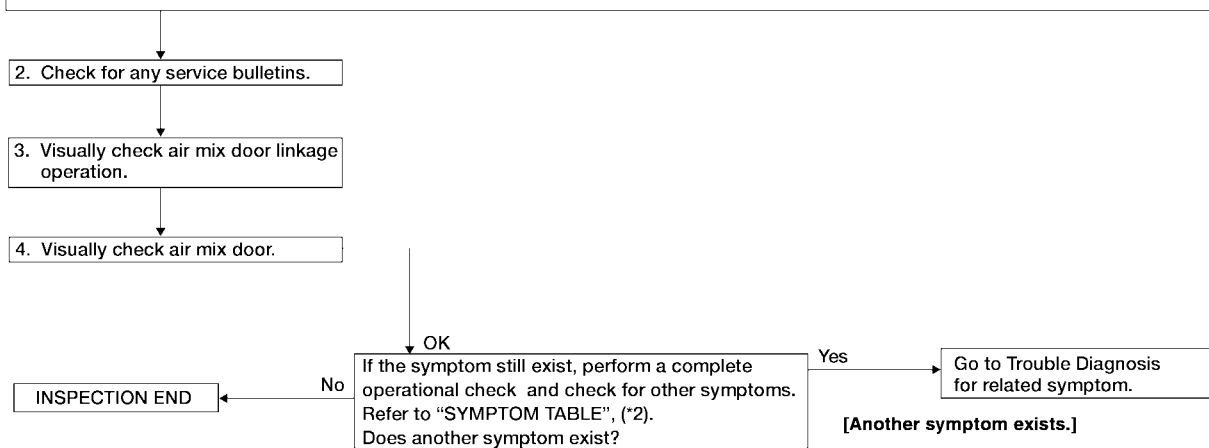

*1 [MTC-35](#)

*2 [MTC-34](#)

WHA190

INTAKE DOOR

Temperature Control Linkage Adjustment

EJS001B0

Temperature Control Cable

- Turn temperature control knob to the full cold position.
- Set the air mix door lever in the full cold position by hand.
- Pull on cable cover in the direction of the arrow and then clamp cable cover.

After positioning air mix door control cable, check for proper operation.

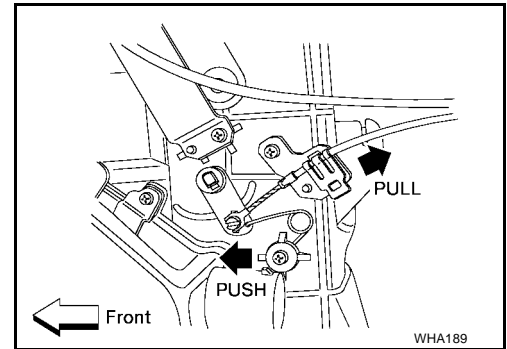

A

B

C

D

E

F

G

H

I

MTC

K

L

M

BLOWER MOTOR

PF2:27226

EJS001B1

BLOWER MOTOR

Trouble Diagnosis Procedure for Blower Motor

SYMPTOM:

- Blower motor does not rotate at all.

INSPECTION FLOW

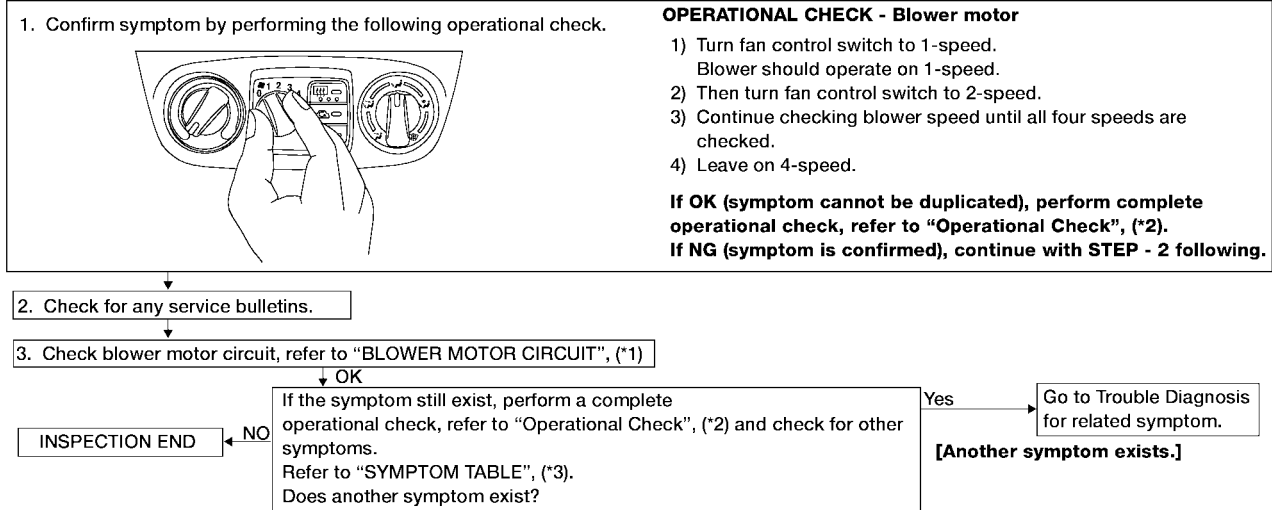

LHA138

*1 [MTC-46](#)

*2 [MTC-35](#)

*3 [MTC-34](#)

Blower Motor Circuit

EJS001B2

SYMPTOM:

- Blower motor does not rotate.

Symptom table No.	INCIDENT
1	Fan fails to rotate.
2	Fan does not rotate at 1-speed.
3	Fan does not rotate at 2-speed.
4	Fan does not rotate at 3-speed.
5	Fan does not rotate at 4-speed.

1. DIAGNOSTIC PROCEDURE

Check if blower motor rotates properly at each fan speed.
Conduct checks as per symptom table above.

- 1 >> GO TO 2.
2, 3, 4 >> GO TO 8.
5 >> GO TO 10.

BLOWER MOTOR

2. CHECK POWER SUPPLY FOR BLOWER MOTOR

1. Disconnect blower motor harness connector.
2. Do approx. 12 volts exist between blower motor harness terminal + and body ground?

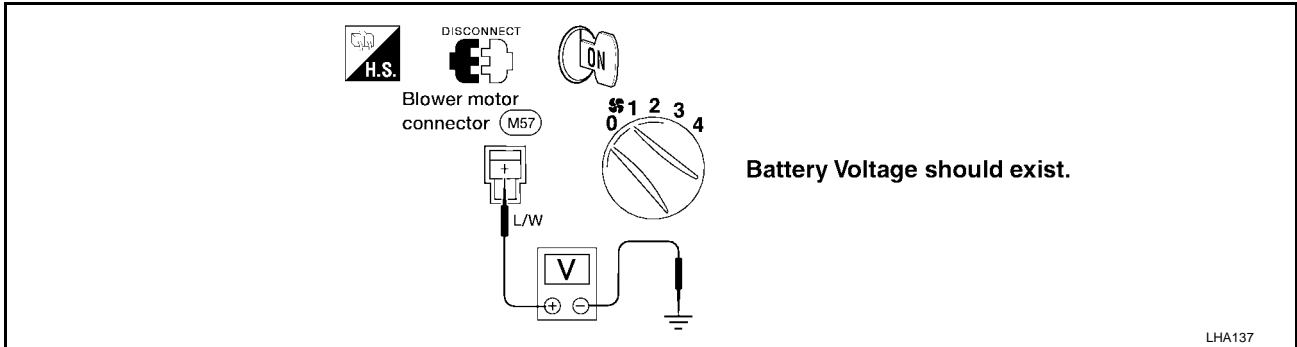

Yes or No

Yes >> GO TO 3.

No >> Check 15A (Nos. 14 and 16) fuses at fuse block. Refer to [PG-9, "IGNITION POWER SUPPLY — IGNITION SW. IN "ON" .](#)

3. CHECK CIRCUIT CONTINUITY FOR BLOWER MOTOR

1. Turn fan control switch to any position except OFF.
2. Check circuit continuity between blower motor connector M57 terminal – (L/B) and body ground.

Continuity should exist.

OK or NG

OK >> GO TO 4.

NG >> Reconnect blower motor harness connector. GO TO 5.

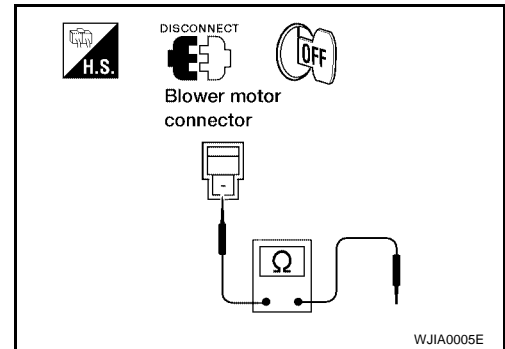

4. CHECK BLOWER MOTOR

Refer to [MTC-50, "BLOWER MOTOR" .](#)

OK or NG

OK >> **INSPECTION END.**

NG >> Replace blower motor.

BLOWER MOTOR

5. CHECK BLOWER MOTOR CIRCUIT BETWEEN BLOWER MOTOR AND FAN RESISTOR

Do approx. 12 volts exist between fan resistor harness terminal No. 1 and body ground?

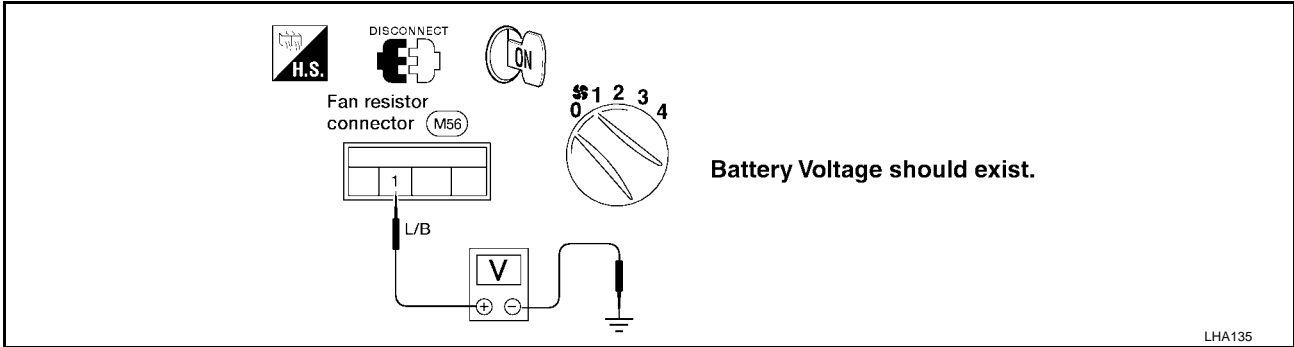

Yes or No

Yes >> Disconnect fan control switch harness connector. GO TO 7.

No >> Disconnect blower motor and fan resistor harness connectors. GO TO 6.

6. CHECK CIRCUIT CONTINUITY BETWEEN BLOWER MOTOR AND FAN RESISTOR

Check circuit continuity between blower motor harness terminal – and fan resistor harness terminal No. 1.

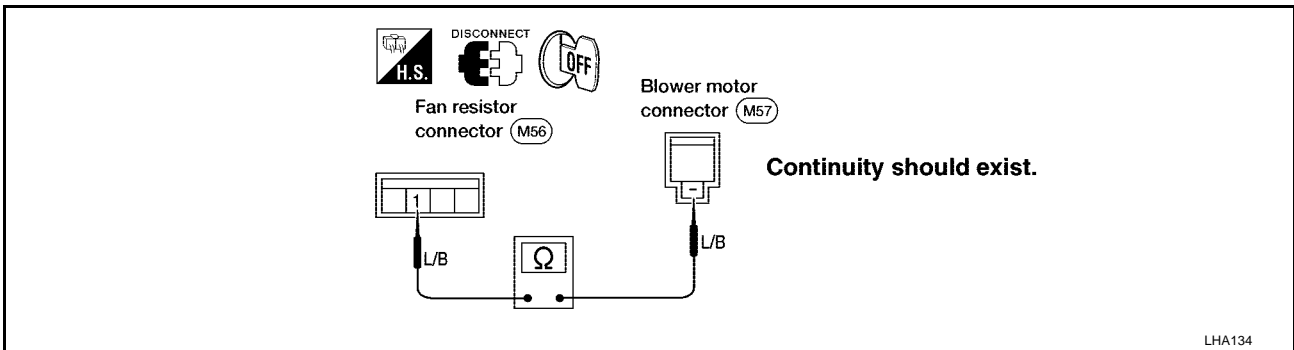

OK or NG

OK >> Check harness for short and repair as necessary.

NG >> Check harness for open and check connectors. Repair as necessary.

7. CHECK GROUND CIRCUIT FOR FAN CONTROL SWITCH

Check circuit continuity between fan control switch harness terminal No. 5 and body ground.

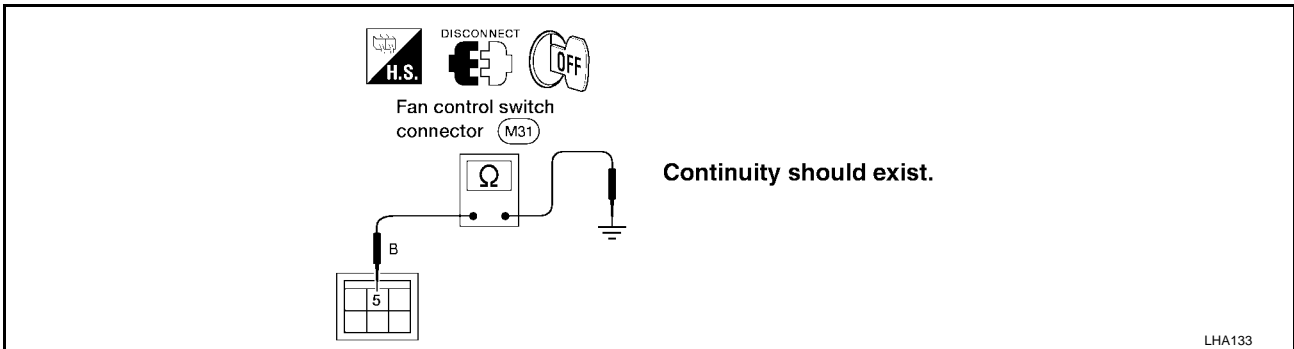

OK or NG

OK >> GO TO 8.

NG >> Repair harness or connector.

BLOWER MOTOR

8. CHECK RESISTOR AFTER DISCONNECTING IT

Refer to [MTC-50, "FAN RESISTOR"](#) .

OK or NG

- OK >> GO TO 9.
- NG >> Replace fan resistor.

9. CHECK FAN RESISTOR HARNESS CONNECTOR

Reconnect fan resistor harness connector.

- 1 >> GO TO 12.
- 2, 3, 4 >> GO TO 10.

10. CHECK FAN CONTROL SWITCH CIRCUIT

Do approx. 12 volts exist between each fan control switch harness terminal and body ground?

Symptom table No.	Terminal No.		Voltage
	(+)	(-)	
2	4	Body ground	Approx. 12V
3	3		
4	2		
5	1		

LHA131

Yes or No

- Yes >> GO TO 12.
- No >> GO TO 11.

11. CHECK CIRCUIT CONTINUITY BETWEEN FAN CONTROL SWITCH AND FAN RESISTOR

Check circuit continuity between fan control switch harness terminal and fan resistor harness terminal.

Terminal No.		Continuity
Fan control switch	Fan resistor	
1	1	Yes
2	2	
3	3	
4	4	

LHA132

OK or NG

- OK >> Check harness for short and repair as necessary.
- NG >> Check harness for open and check connectors. Repair as necessary.

12. CHECK FAN CONTROL SWITCH AFTER DISCONNECTING IT

Refer to [MTC-50, "FAN CONTROL SWITCH"](#) .

OK or NG

- OK >> **INSPECTION END.**
- NG >> Replace fan control switch.

BLOWER MOTOR

EJS001B3

Electrical Components Inspection FAN CONTROL SWITCH

Check continuity between terminals at each switch position.

Fan control switch position	Continuity between terminals
OFF	
1	4 — 5 — 6
2	3 — 5 — 6
3	2 — 5 — 6
4	1 — 5 — 6

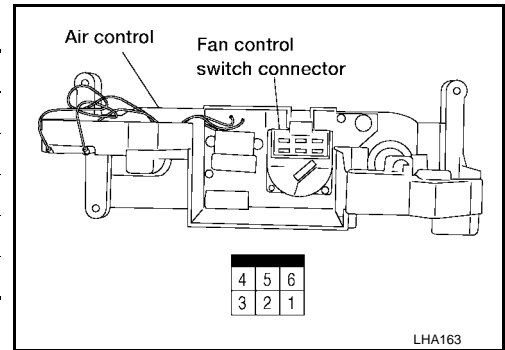

BLOWER MOTOR

Confirm smooth rotation of the blower motor.

- Ensure that there are no foreign particles inside the intake unit.

FAN RESISTOR

Check resistance between terminals.

Terminal No.		Resistance (Approx.)
(+)	(-)	
3	1	1.305 - 1.595Ω
4		2.457 - 3.003Ω
2		0.225 - 0.275Ω

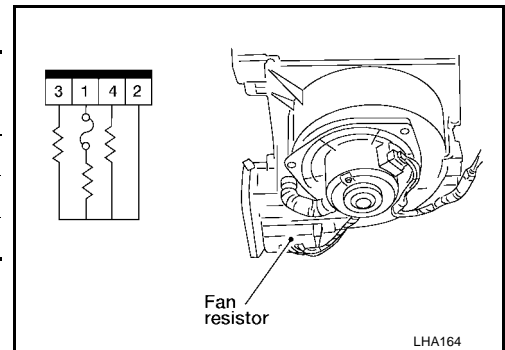

MAGNET CLUTCH

PFP:92660

EJS001B4

MAGNET CLUTCH

Trouble Diagnosis Procedure for Magnet Clutch

SYMPTOM:

- Magnet clutch does not operate when A/C switch and fan control switch are ON.

INSPECTION FLOW

1. Confirm symptom by performing the following operational check.

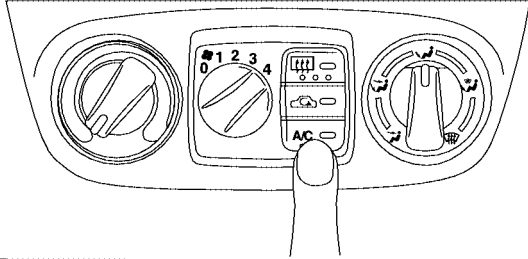

OPERATIONAL CHECK - A/C switch

Turn fan control switch to the desired (1 to 4-speed) position and push the air conditioner switch to turn ON the air conditioner. The indicator light should come on when air conditioner is ON.

If OK (symptom cannot be duplicated), perform complete operational check, refer to "Operational Check", (*3).
If NG (symptom is confirmed), continue with STEP-2 following.

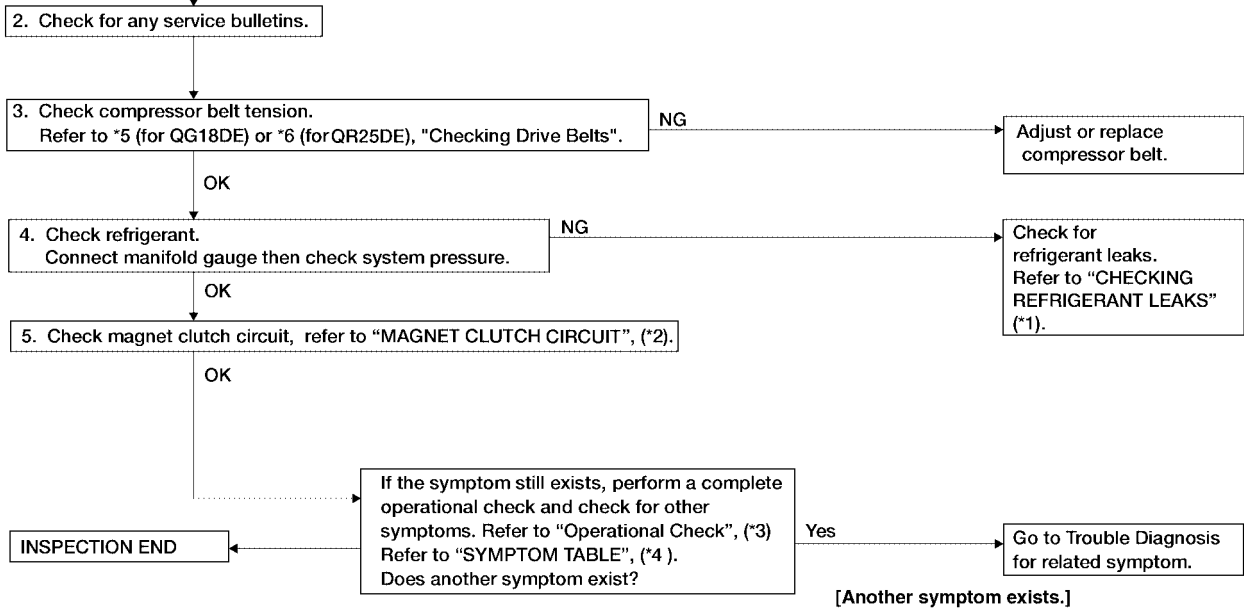

*1 [MTC-86](#)

*2 [MTC-52](#)

*3 [MTC-35](#)

*4 [MTC-34](#)

*5 [MA-16](#)

*6 [MA-23](#)

WJIA0006E

MAGNET CLUTCH

EJS001B5

Magnet Clutch Circuit

SYMPTOM:

- Magnet clutch does not engage when A/C switch and fan control switch are ON.

1. CHECK POWER SUPPLY FOR COMPRESSOR

Disconnect compressor harness connector.

Do approx. 12 volts exist between compressor harness connector E36 terminal 1, (L/R) and body ground?

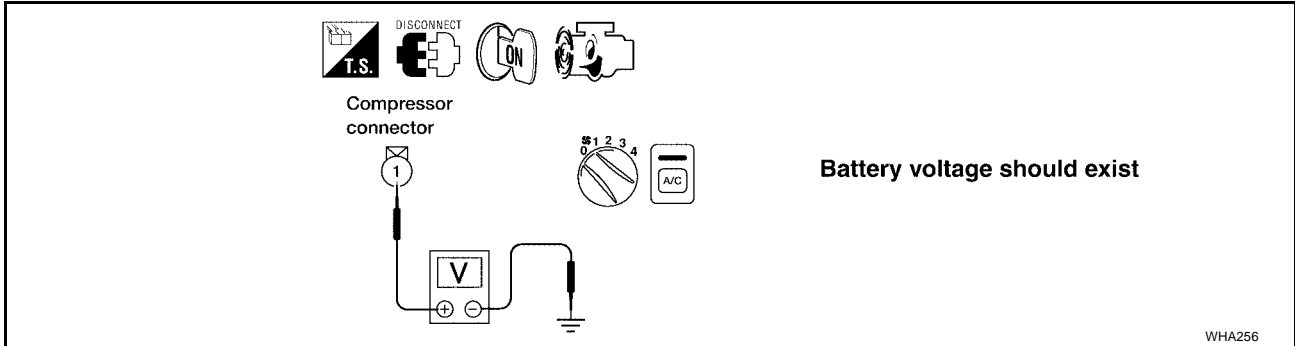

Yes or No

Yes >> GO TO 2.

No >> GO TO 3.

2. CHECK MAGNET CLUTCH COIL

Disconnect magnet clutch connector.

Do approx. 3.2Ω exist between A/C compressor harness connector E36 terminal 1, (L/R) and body ground?

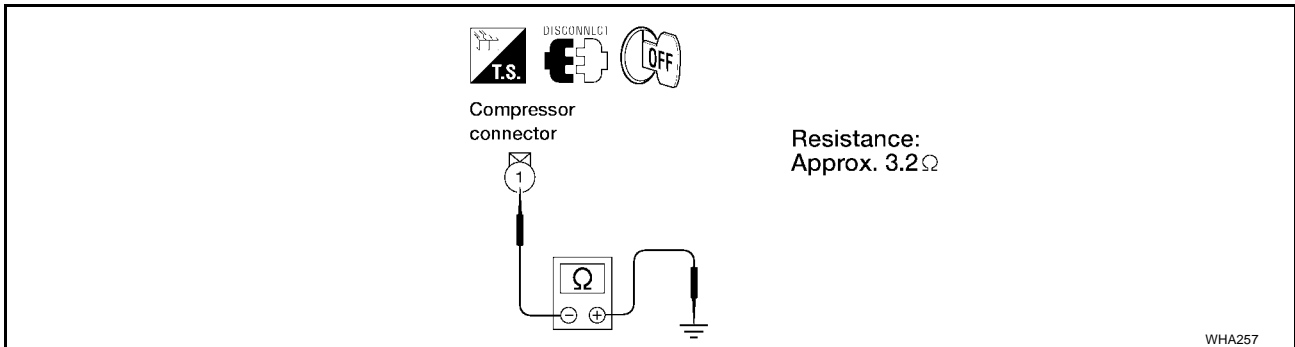

Yes or No

Yes >> **INSPECTION END.**

No >> Replace magnet clutch. Refer to [MTC-69, "COMPRESSOR CLUTCH"](#).

MAGNET CLUTCH

3. CHECK CIRCUIT CONTINUITY BETWEEN A/C RELAY AND COMPRESSOR HARNESS

Disconnect A/C relay.

Check circuit continuity between A/C relay harness terminal 3 and compressor harness terminal 1.

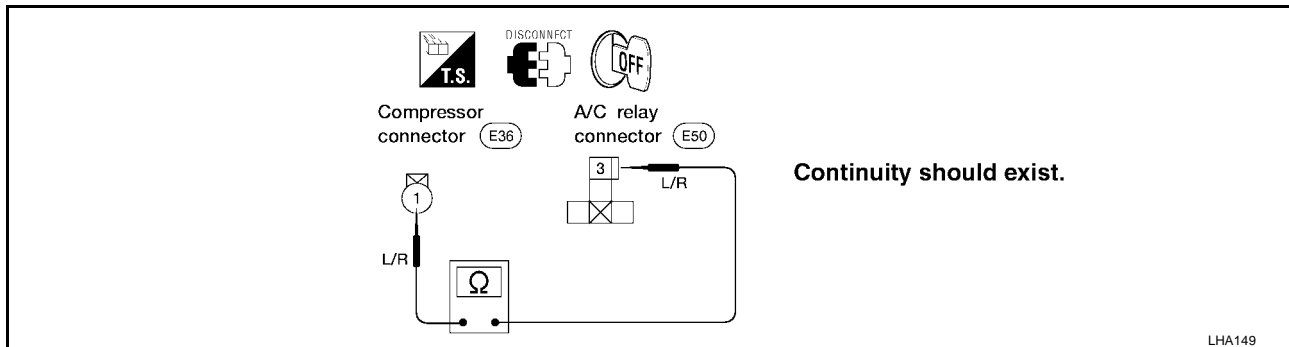

If OK, check harness for short.

OK or NG

OK >> GO TO 4.

NG >> Repair harness or connector.

4. CHECK INTAKE SENSOR CIRCUIT

Refer to [MTC-66, "Intake Sensor Circuit"](#) .

OK or NG

OK >> GO TO 5.

NG >> Repair as necessary.

5. CHECK POWER SUPPLY FOR A/C RELAY

Disconnect A/C relay.

Do approx. 12 volts exist between A/C relay harness terminal 1, 5 and body ground?

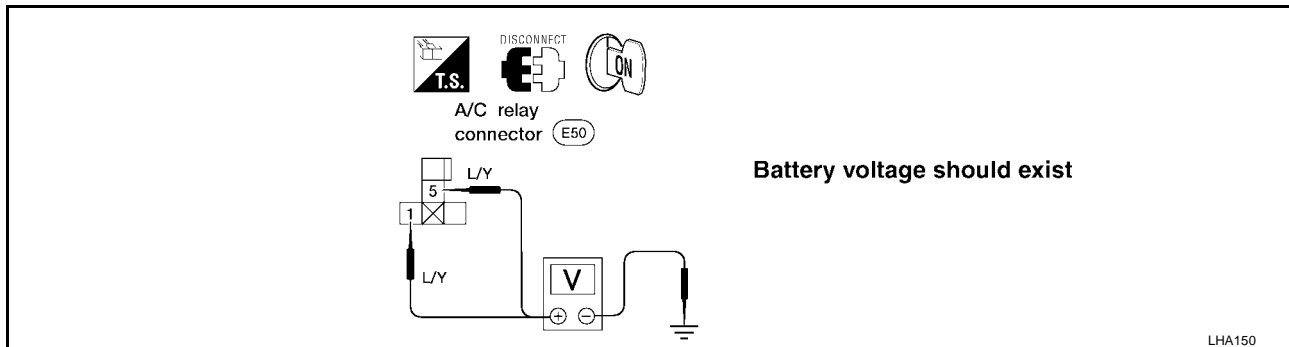

Yes or No

Yes >> GO TO 6.

No >> Check power supply circuit and 10A (No. 15) fuse at fuse block. Refer to [PG-9, "IGNITION POWER SUPPLY — IGNITION SW. IN "ON" "](#) .

6. CHECK A/C RELAY AFTER DISCONNECTING IT

Refer to [MTC-55, "A/C RELAY"](#) .

OK or NG

OK >> Reconnect A/C relay. GO TO 7.

NG >> Replace A/C relay.

MAGNET CLUTCH

7. CHECK COIL SIDE CIRCUIT OF A/C RELAY

Reconnect A/C relay.

Do approx. 12 volts exist between ECM harness connector F59 terminal 105 (L) and body ground?

Battery voltage should exist.

Yes or No

Yes >> GO TO 9.

No >> Disconnect A/C relay. Disconnect ECM harness connector. GO TO 8.

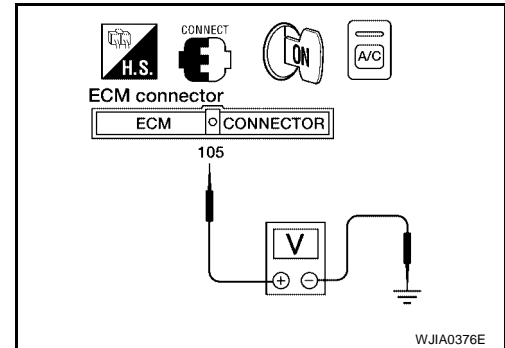

8. CHECK CIRCUIT CONTINUITY BETWEEN A/C RELAY AND ECM HARNESS

Check circuit continuity between A/C relay harness connector E50 terminal 2 (L) and ECM harness connector F59 terminal 105 (L).

Continuity should exist.

If OK, check harness for short.

OK or NG

OK >> Check ECM. Refer to [EC-106, "ECM Terminals and Reference Value"](#) (with QG18DE), or [EC-746, "ECM Terminals and Reference Value"](#) (with QR25DE).

NG >> Repair harness or connector.

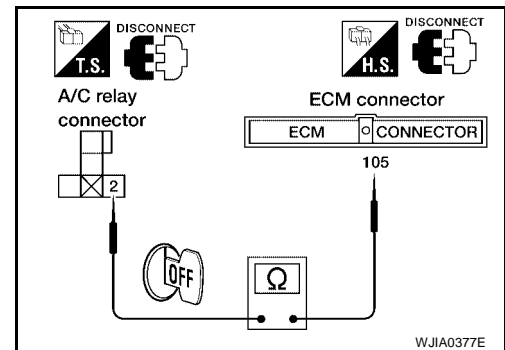

9. CHECK VOLTAGE FOR ECM

Do approx. 12 volts exist between ECM harness connector F59 terminal No. 110 (L/R) and body ground?

Battery voltage should exist.

Yes or No

Yes >> GO TO 10.

No >> Check ECM. Refer to [EC-106, "ECM Terminals and Reference Value"](#) (with QG18DE), or [EC-746, "ECM Terminals and Reference Value"](#) (with QR25DE).

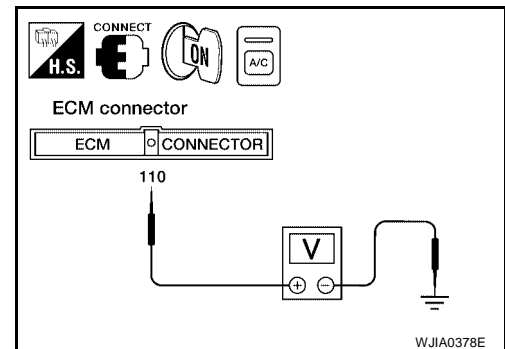

10. CHECK REFRIGERANT PRESSURE SENSOR

Refer to [MTC-56, "REFRIGERANT PRESSURE SENSOR"](#).

OK or NG

OK >> GO TO 11.

NG >> Replace refrigerant pressure sensor.

MAGNET CLUTCH

11. CHECK CIRCUIT CONTINUITY BETWEEN FAN CONTROL SWITCH AND A/C CONTROL UNIT

Disconnect A/C control unit and fan control switch.
Check circuit continuity between fan control switch harness connector M31 terminal No. 6 (Y/G) and A/C control unit harness connector M32 terminal No. 8 (Y/G).

Continuity should exist.

If OK, check harness for short.

OK or NG

- OK >> GO TO 12.
- NG >> Repair harness or connector.

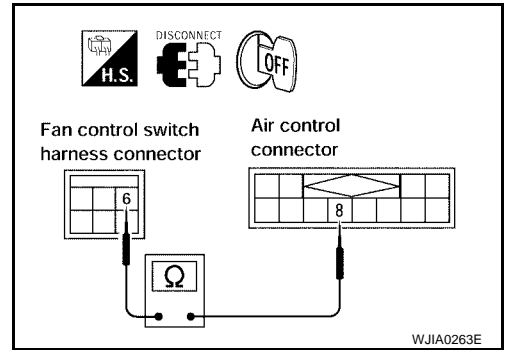

12. CHECK FAN CONTROL SWITCH GROUND

Disconnect fan control switch harness connector.
Does continuity exist between fan control switch harness terminal No. 5 and body ground?

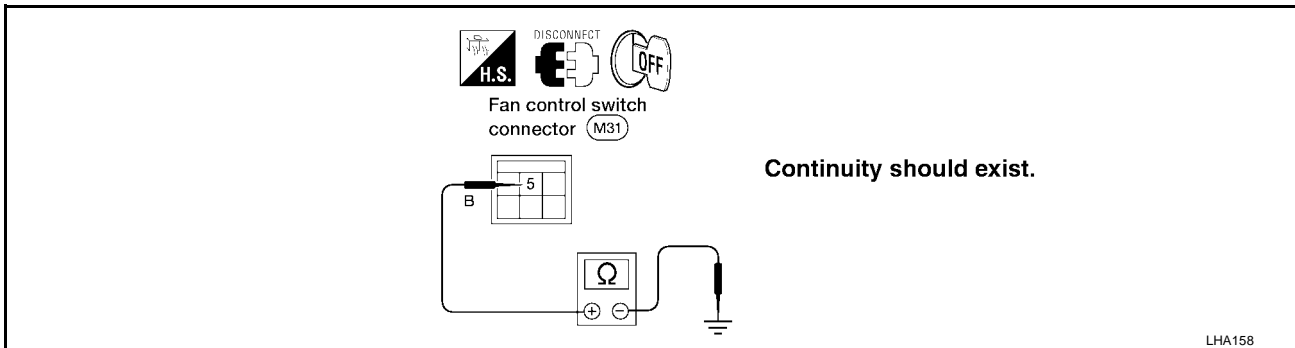

Yes or No

- Yes >> Replace A/C control unit.
- No >> Repair harness or connector.

Electrical Component Inspection A/C RELAY

EJS001B6

Check continuity between terminal Nos. 3 and 5.

Conditions	Continuity
12V direct current supply between terminal Nos. 1 and 2	Yes
No current supply	No

If NG, replace relay.

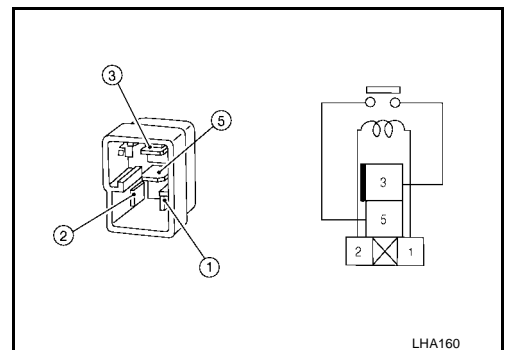

MAGNET CLUTCH

REFRIGERANT PRESSURE SENSOR

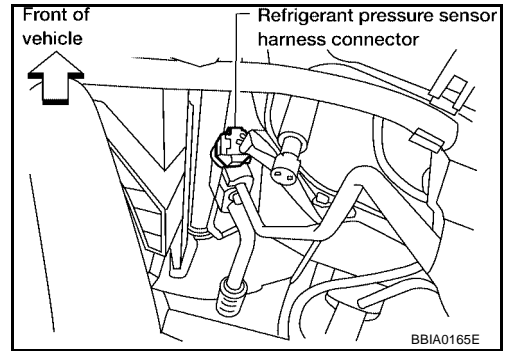

Make sure that higher A/C refrigerant pressure results in higher refrigerant pressure sensor output voltage.

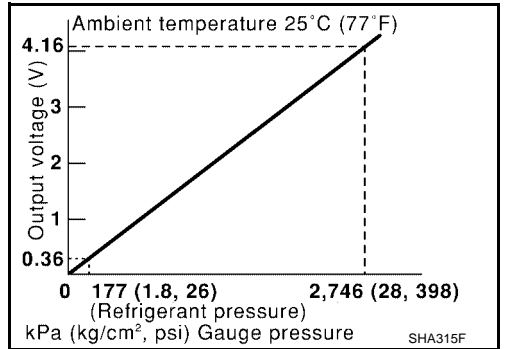

INSUFFICIENT COOLING

PFP:00000

INSUFFICIENT COOLING

Trouble Diagnosis Procedure for Insufficient Cooling

EJS001B7

SYMPTOM:

- Insufficient cooling

INSPECTION FLOW

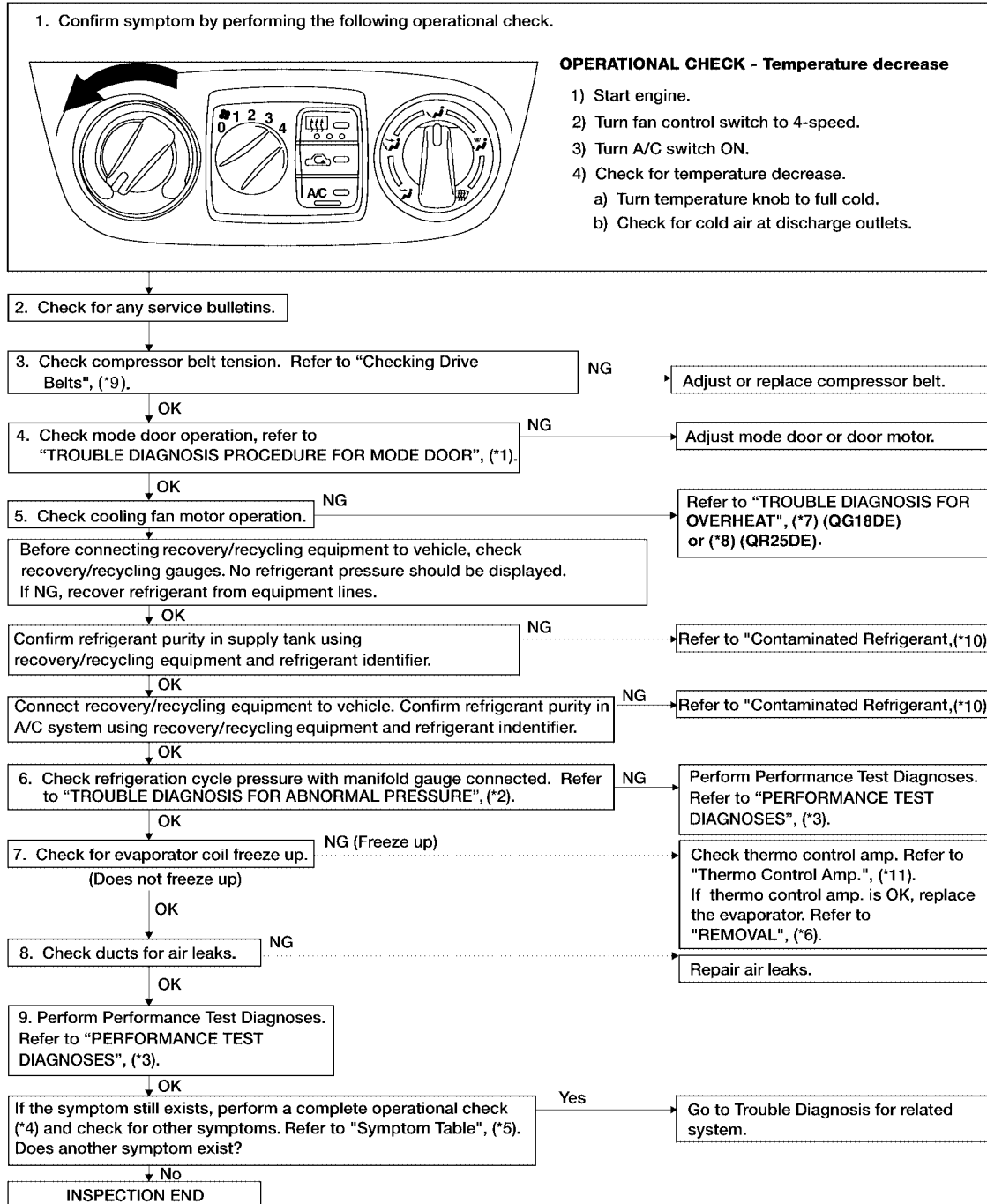

WJJA0364E

*1 [MTC-42](#)

*2 [MTC-61](#)

*3 [MTC-58](#)

*4 [MTC-35](#)

*5 [MTC-34](#)

*6 [MTC-80](#)

*7 [EC-1092](#)

*8 [EC-1092](#)

*9 [MA-17](#) (QG18DE) or [MA-24](#) (QR25DE)

*10 [MTC-3](#)

*11 [MTC-66](#)

INSUFFICIENT COOLING

Performance Test Diagnoses

EJS001B8

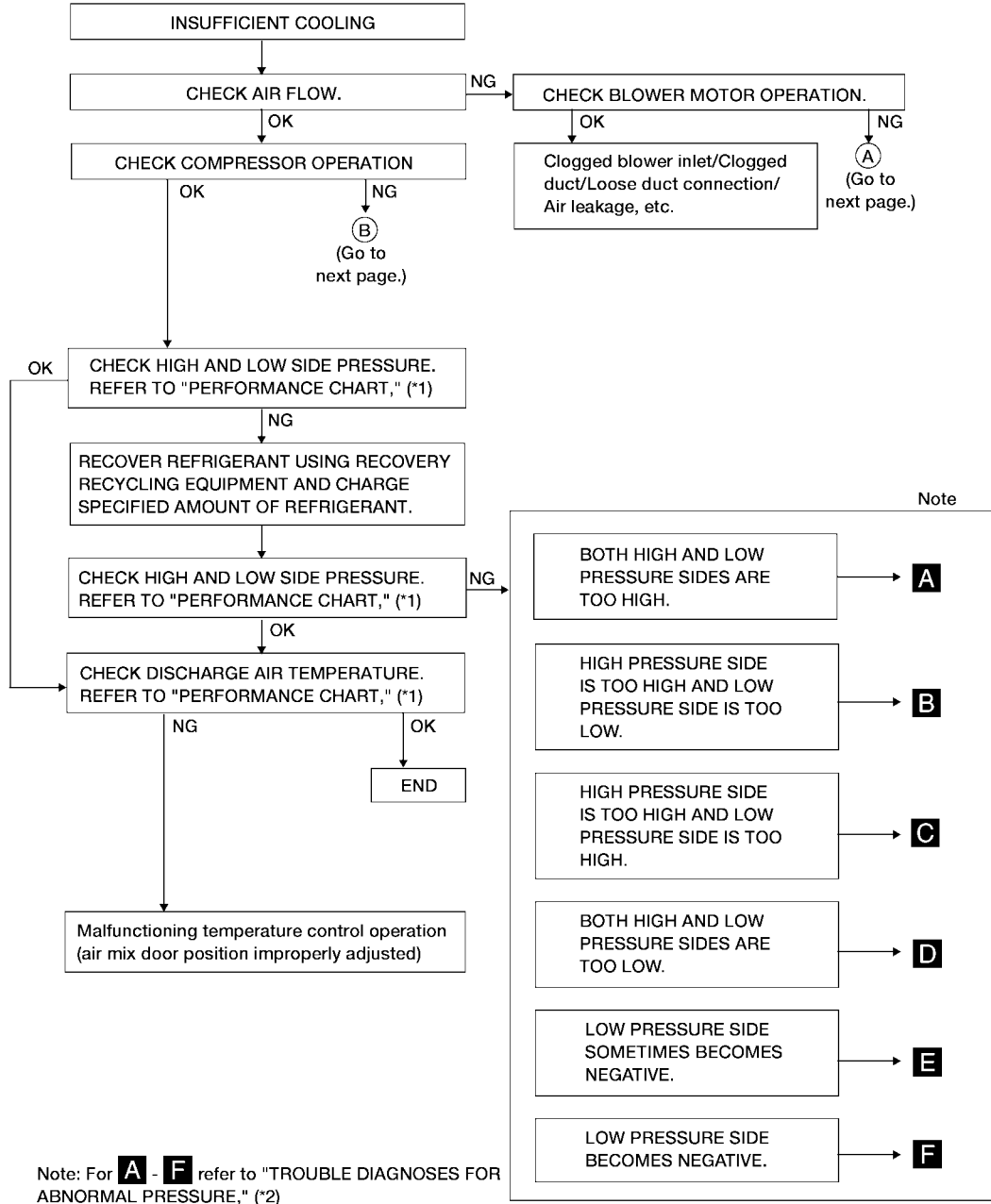

*1 [MTC-60](#)

*2 [MTC-61](#)

LHA196

INSUFFICIENT COOLING

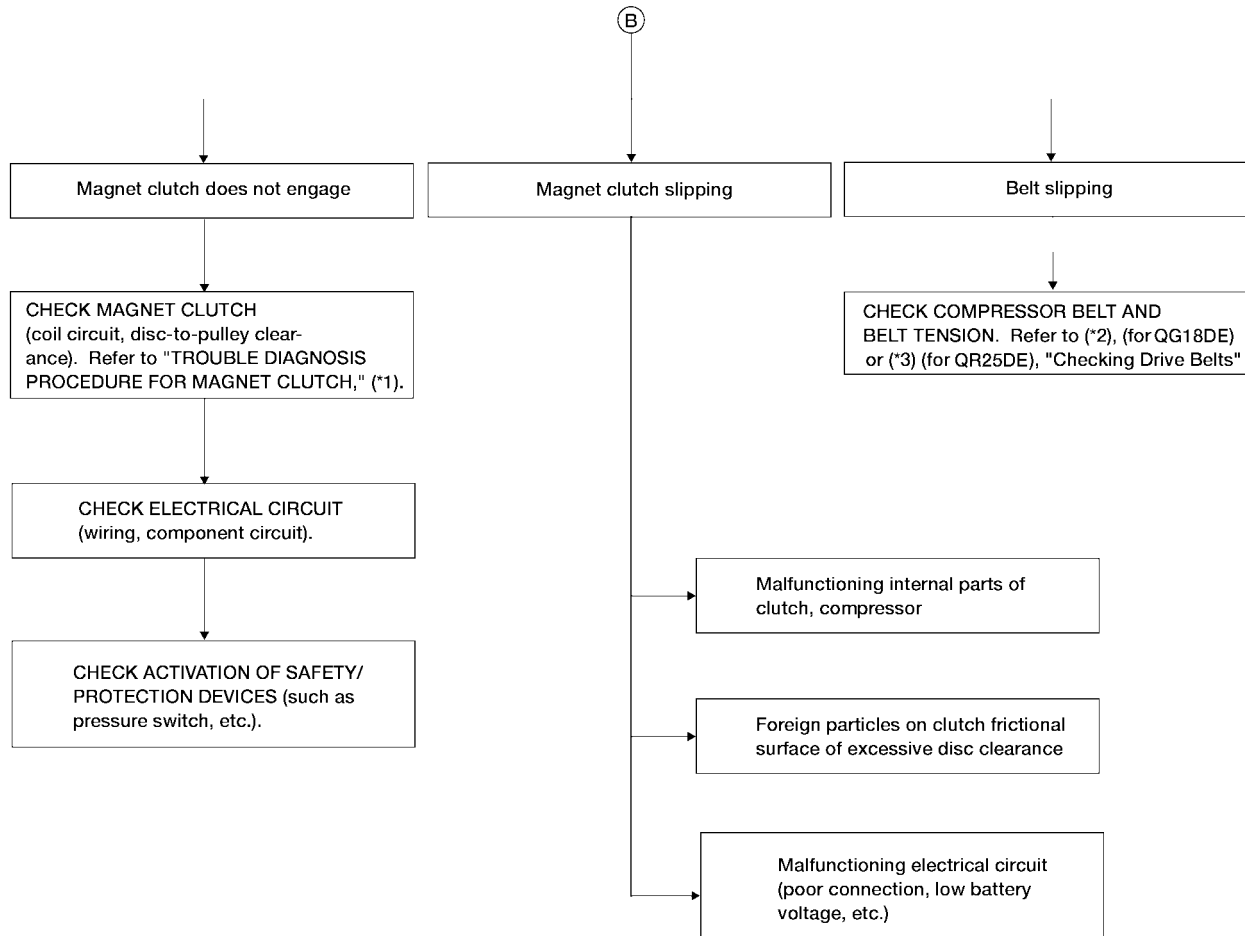
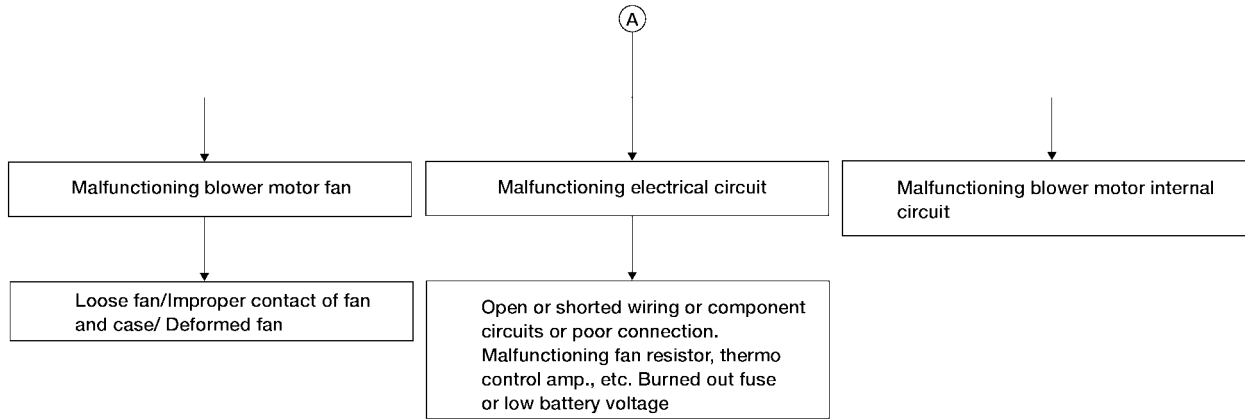

*1 [MTC-51](#)

*2 [MA-16](#)

*3 [MA-23](#)

WJIA0008E

A
B
C
D
E
F
G
H
I
K
L
M

MTC

INSUFFICIENT COOLING

Performance Chart

EJS001B9



The Nissan A/C system uses a thermal expansion valve to provide a restriction which causes a pressure change and also controls refrigerant flow through the evaporator.

The best way to diagnose a condition in the refrigerant system is to note the system pressures (shown by the manifold gauges) and the clutch cycle rate and times. Then, compare the findings to the charts.

- The system pressures are low (compressor suction) and high (compressor discharge).
- A clutch cycle is the time the clutch is engaged plus the time it is disengaged (time on plus time off).
- Clutch cycle times are the lengths of time (in seconds) that the clutch is ON and OFF.

TEST CONDITION

Testing must be performed as follows:

Vehicle location	Indoors or in the shade (in a well-ventilated place)
Doors	Closed
Door windows	Open
Hood	Open
TEMP. switch	Max. COLD
Mode switch	 (Ventilation) set
REC switch	 (Recirculation) set
 (blower) speed	4-speed
Engine speed	1,500 rpm

Operate the air conditioning system for 10 minutes before taking measurements.

TEST READING

Recirculating-to-Discharge Air Temperature Table

Inside air (Recirculating air) at blower assembly inlet		Discharge air temperature at center ventilator °C (°F)
Relative humidity %	Air temperature °C (°F)	
50 - 60	20 (68)	6.6 - 8.3 (44 - 47)
	25 (77)	10.4 - 12.4 (51 - 54)
	30 (86)	14.2 - 16.7 (58 - 62)
	35 (95)	18.2 - 21 (65 - 70)
	40 (104)	22.0 - 25.2 (72 - 77)
60 - 70	20 (68)	8.3 - 9.8 (47 - 50)
	25 (77)	12.4 - 14.4 (54 - 58)
	30 (86)	16.7 - 18.9 (62 - 66)
	35 (95)	21.0 - 23.6 (70 - 74)
	40 (104)	25.2 - 28.1 (77 - 83)

Ambient Air Temperature-to-Operating Pressure Table

Ambient air		High-pressure (Discharge side) kPa (kg/cm ² , psi)	Low-pressure (Suction side) kPa (kg/cm ² , psi)
Relative humidity %	Air temperature °C (°F)		
50 - 70	20 (68)	961 - 1,187 (9.8 - 12.1, 139 - 172)	108 - 157 (1.1 - 1.6, 16 - 23)
	25 (77)	1,295 - 1,599 (13.2 - 16.3, 186 - 228)	161.8 - 215.8 (1.65 - 2.2, 23.5 - 31.3)
	30 (86)	1,285 - 1,599 (13.1 - 16.0, 186 - 228)	167 - 216 (1.7 - 2.2, 24 - 31)
	35 (95)	1,520 - 1,863 (15.5 - 19.0, 220 - 279)	235 - 284 (2.4 - 2.9, 34 - 41)
	40 (104)	1,765 - 2,158 (18 - 22, 256 - 313)	289.3 - 353.1 (2.95 - 3.6, 41.9 - 51.2)

INSUFFICIENT COOLING

EJS001BA

Trouble Diagnoses for Abnormal Pressure

Whenever system's high and/or low side pressure is abnormal, diagnose using a manifold gauge. The marker above the gauge scale in the following tables indicates the standard (normal) pressure range. However, since the standard (normal) pressure differs from vehicle to vehicle, refer to [MTC-60, "Ambient Air Temperature-to-Operating Pressure Table"](#).

BOTH HIGH AND LOW-PRESSURE SIDES ARE TOO HIGH.

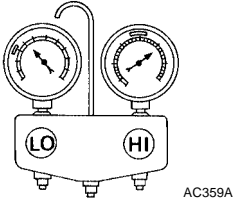
Gauge indication	Refrigerant cycle	Probable cause	Corrective action
<p>Both high and low-pressure sides are too high.</p> <p>A</p>  <p style="text-align: right; font-size: small;">AC359A</p>	<ul style="list-style-type: none"> Pressure is reduced soon after water is splashed on condenser. 	<p>Excessive refrigerant charge in refrigeration cycle</p>	<p>Reduce refrigerant until specified pressure is obtained.</p>
	<p>Air suction by cooling fan is insufficient.</p>	<p>Insufficient condenser cooling performance</p> <p style="text-align: center;">↓</p> <p>1. Condenser fins are clogged.</p> <p>2. Improper fan rotation of cooling fan</p>	<ul style="list-style-type: none"> Clean condenser. Check and repair cooling fan as necessary.
	<ul style="list-style-type: none"> Low-pressure pipe is not cold. When compressor is stopped high-pressure value quickly drops by approximately 196 kPa (2 kg/cm², 28 psi). It then decreases gradually thereafter. 	<p>Poor heat exchange in condenser (After compressor operation stops, high pressure decreases too slowly.)</p> <p style="text-align: center;">↓</p> <p>Air in refrigeration cycle</p>	<p>Evacuate repeatedly and recharge system.</p>
	<p>Engine tends to overheat.</p>	<p>Engine cooling systems malfunction.</p>	<p>Check and repair each engine cooling system.</p>
	<ul style="list-style-type: none"> An area of the low-pressure pipe is colder than areas near the evaporator outlet. Plates are sometimes covered with frost. 	<ul style="list-style-type: none"> Excessive liquid refrigerant on low-pressure side Excessive refrigerant discharge flow Expansion valve is open a little compared with the specification. <p style="text-align: center;">↓</p> <p>1. Improper thermal valve installation</p> <p>2. Improper expansion valve adjustment</p>	<p>Replace expansion valve.</p>

HIGH-PRESSURE SIDE IS TOO HIGH AND LOW-PRESSURE SIDE IS TOO LOW.

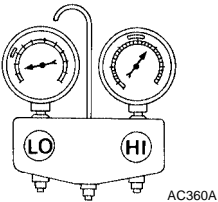
Gauge indication	Refrigerant cycle	Probable cause	Corrective action
<p>High-pressure side is too high and low-pressure side is too low.</p> <p>B</p>  <p style="text-align: right; font-size: small;">AC360A</p>	<p>Upper side of condenser and high-pressure side are hot, however, liquid tank is not so hot.</p>	<p>High-pressure tube or parts located between compressor and condenser are clogged or crushed.</p>	<ul style="list-style-type: none"> Check and repair or replace malfunctioning parts. Check lubricant for contamination.

INSUFFICIENT COOLING

HIGH-PRESSURE SIDE IS TOO LOW AND LOW-PRESSURE SIDE IS TOO HIGH.

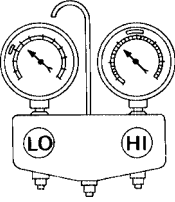
Gauge indication	Refrigerant cycle	Probable cause	Corrective action
High-pressure side is too low and low-pressure side is too high. C  AC356A	High and low-pressure sides become equal soon after compressor operation stops.	Compressor pressure operation is improper. ↓ Damaged inside compressor packings	Replace compressor.
	No temperature difference between high and low-pressure sides	Compressor pressure operation is improper. ↓ Damaged inside compressor packings.	Replace compressor.

BOTH HIGH- AND LOW-PRESSURE SIDES ARE TOO LOW.

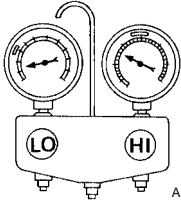
Gauge indication	Refrigerant cycle	Probable cause	Corrective action
Both high- and low-pressure sides are too low. D  AC353A	<ul style="list-style-type: none"> There is a big temperature difference between receiver drier outlet and inlet. Outlet temperature is extremely low. Liquid tank inlet and expansion valve are frosted. 	Compressor discharge capacity does not change. (Compressor stroke is set at maximum.)	<ul style="list-style-type: none"> Replace liquid tank. Check lubricant for contamination.
	<ul style="list-style-type: none"> Temperature of expansion valve inlet is extremely low as compared with areas near liquid tank. Expansion valve inlet may be frosted. Temperature difference occurs somewhere in high-pressure side 	High-pressure pipe located between receiver drier and expansion valve is clogged.	<ul style="list-style-type: none"> Check and repair malfunctioning parts. Check lubricant for contamination.
	<ul style="list-style-type: none"> Expansion valve and liquid tank are warm or only cool when touched. 	Low refrigerant charge ↓ Leaking fittings or components	Check refrigerant for leaks. Refer to MTC-86, "Checking Refrigerant Leaks" .
	There is a big temperature difference between expansion valve inlet and outlet while the valve itself is frosted.	Expansion valve closes a little compared with the specification. ↓ 1. Improper expansion valve adjustment 2. Malfunctioning thermal valve 3. Outlet and inlet may be clogged.	<ul style="list-style-type: none"> Remove foreign particles by using compressed air. Check lubricant for contamination.
	An area of the low-pressure pipe is colder than areas near the evaporator outlet.	Low-pressure pipe is clogged or crushed.	<ul style="list-style-type: none"> Check and repair malfunctioning parts. Check lubricant for contamination.
	Air flow volume is not enough or is too low.	Evaporator is frozen.	<ul style="list-style-type: none"> Check intake sensor operation. Refer to MTC-66, "INTAKE SENSOR" . Replace expansion valve.

INSUFFICIENT COOLING

LOW-PRESSURE SIDE SOMETIMES BECOMES NEGATIVE.

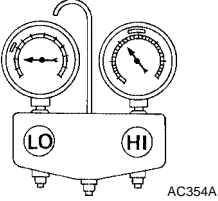
Gauge indication	Refrigerant cycle	Probable cause	Corrective action
<p>Low-pressure side sometimes becomes negative.</p> <p>E</p>  <p style="text-align: right; font-size: small;">AC354A</p>	<ul style="list-style-type: none"> ● Air conditioning system does not function and does not cyclically cool the compartment air. ● The system constantly functions for a certain period of time after compressor is stopped and restarted. 	<p>Refrigerant does not discharge cyclically.</p> <p style="text-align: center;">↓</p> <p>Moisture is frozen at expansion valve outlet and inlet.</p> <p style="text-align: center;">↓</p> <p>Water is mixed with refrigerant.</p>	<ul style="list-style-type: none"> ● Drain water from refrigerant or replace refrigerant. ● Replace liquid tank.

LOW-PRESSURE SIDE BECOMES NEGATIVE.

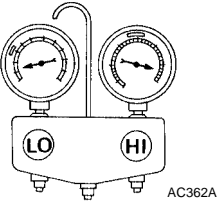
Gauge indication	Refrigerant cycle	Probable cause	Corrective action
<p>Low-pressure side becomes negative.</p> <p>F</p>  <p style="text-align: right; font-size: small;">AC362A</p>	<p>Liquid tank or front/rear side of expansion valve's pipe is frosted or dewed.</p>	<p>High-pressure side is closed and refrigerant does not flow.</p> <p style="text-align: center;">↓</p> <p>Expansion valve or liquid tank is frosted.</p>	<p>Leave the system at rest until no frost is present. Start it again to check whether or not the problem is caused by water or foreign particles.</p> <ul style="list-style-type: none"> ● If water is the cause, initially cooling is okay. Then the water freezes causing a blockage. Drain water from refrigerant or replace refrigerant. ● If due to foreign particles, remove expansion valve and remove particles with dry and compressed air (not shop air). ● If either of the above methods cannot correct the problem, replace expansion valve. ● Replace liquid tank. ● Check lubricant for contamination.

A
B
C
D
E
F
G
H
I
K
L
M

MTC

INSUFFICIENT HEATING

PF0:0000

EJS001BB

INSUFFICIENT HEATING

Trouble Diagnosis Procedure for Insufficient Heating

Symptom:

- Insufficient heating

Inspection Flow

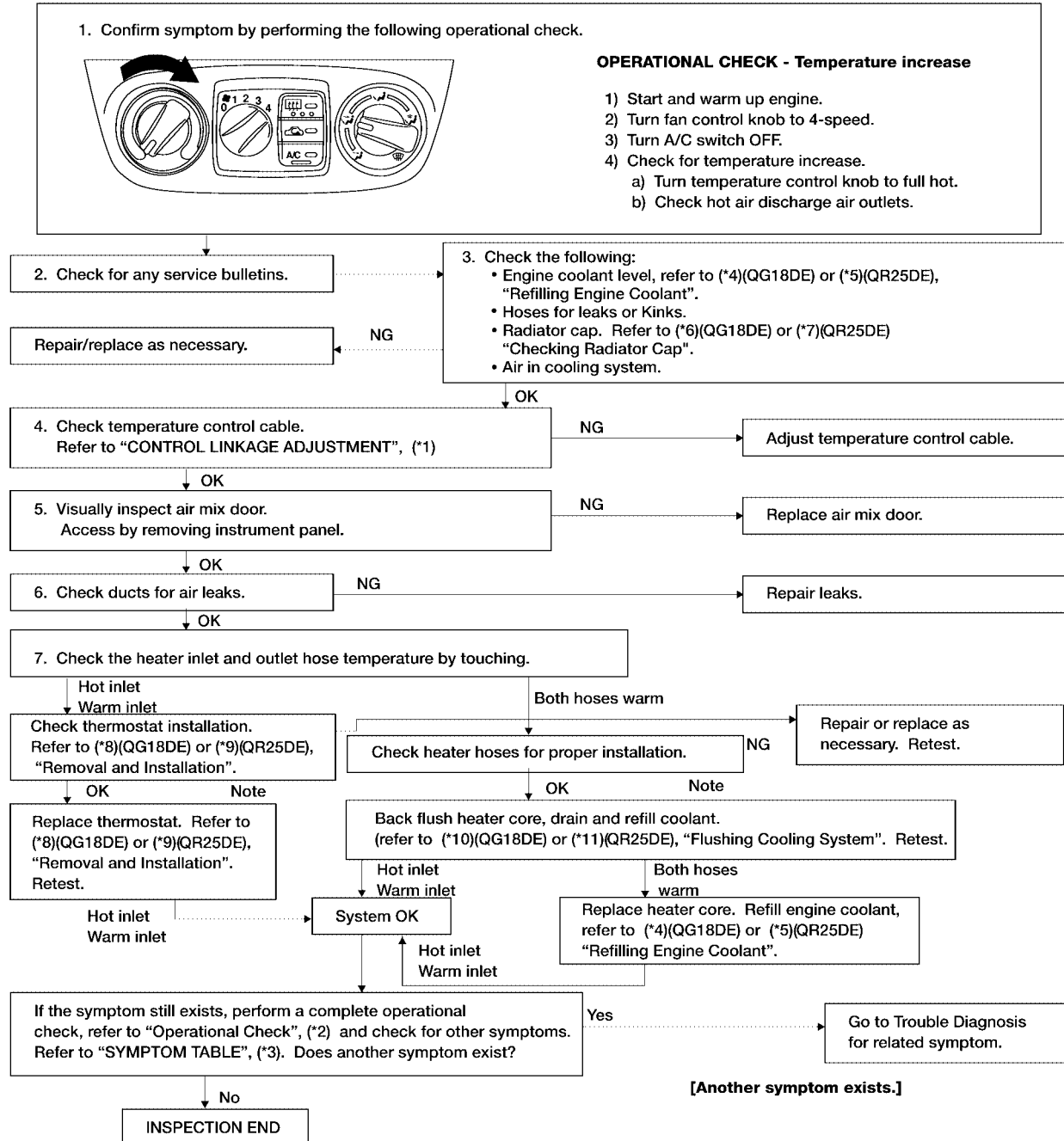

WJJA0009E

*1 [MTC-41](#)

*2 [MTC-35](#)

*3 [MTC-34](#)

*4 [MA-17](#)

*5 [MA-24](#)

*6 [CO-9](#)

*7 [CO-36](#)

*8 [CO-12](#)

*9 [CO-30](#)

*10 [MA-19](#)

*11 [MA-25](#)

NOISE

PF0:00004

EJS001BC

NOISE

Trouble Diagnosis Procedure for Noise

SYMPTOM:

- Noise

INSPECTION FLOW

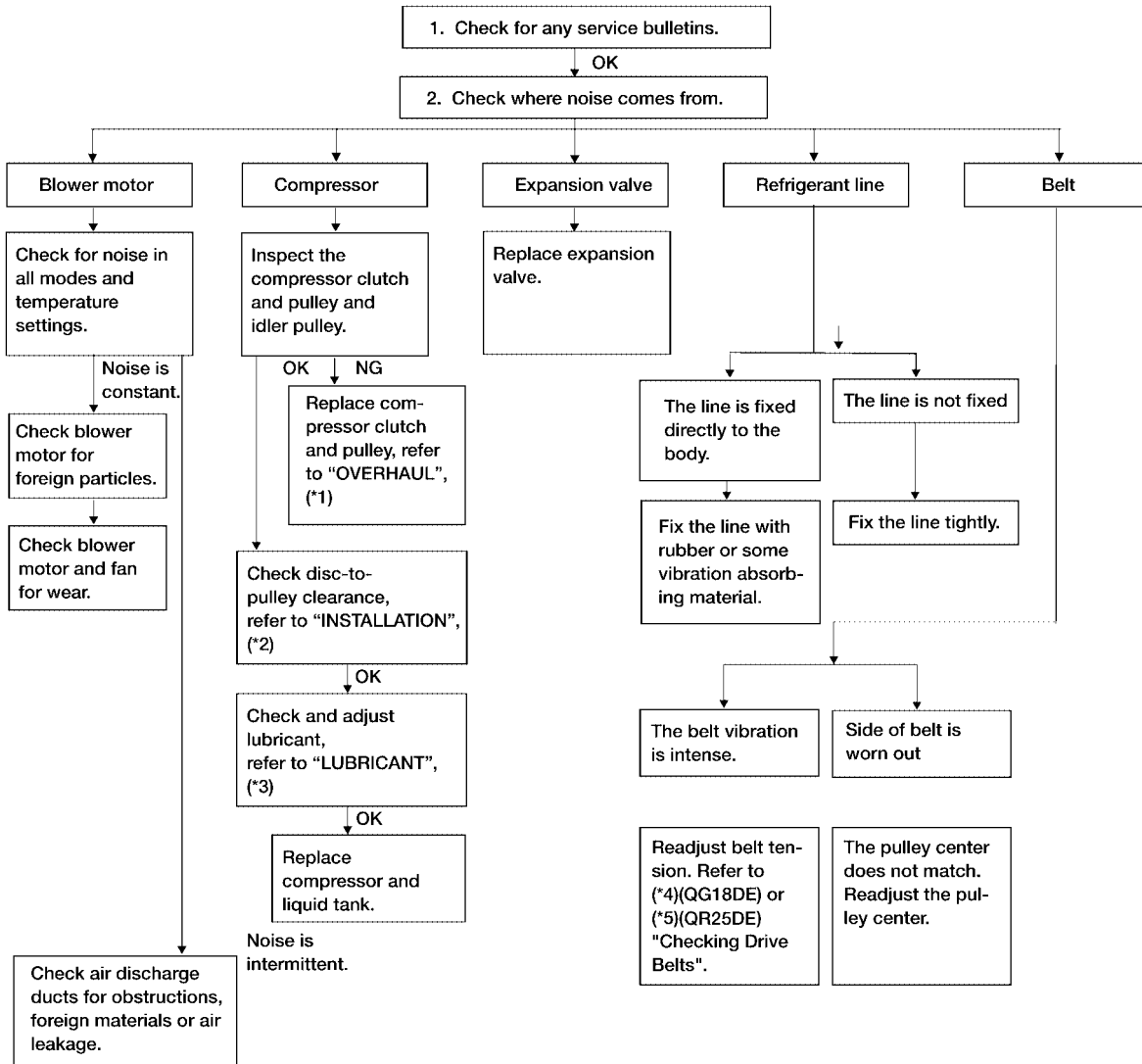

*1 [MTC-69](#)

*4 [MA-16](#)

*2 [MTC-72](#)

*5 [MA-23](#)

*3 [MTC-16](#)

WJIA0214E

INTAKE SENSOR

PF2:27723

EJS001GW

INTAKE SENSOR

Intake Sensor Circuit COMPONENT DESCRIPTION

Intake Sensor

The intake sensor is located on the heater and cooling unit. It converts temperature of air after it passes through the evaporator into a resistance value which is then input to the A/C control unit.

After disconnecting intake sensor harness connector, measure resistance between terminals 1 and 2 at sensor harness side, using the table below.

Temperature °C (°F)	Resistance kΩ
-15 (5)	12.34
-10 (14)	9.62
-5 (23)	7.56
0 (32)	6.00
5 (41)	4.80
10 (50)	3.87
15 (59)	3.15
20 (68)	2.57
25 (77)	2.12
30 (86)	1.76
35 (95)	1.47
40 (104)	1.23
45 (113)	1.04

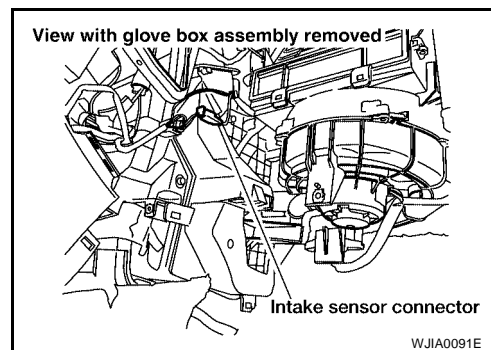

If NG, replace intake sensor.

DIAGNOSTIC PROCEDURE

SYMPTOM: Intake sensor circuit is open or shorted.

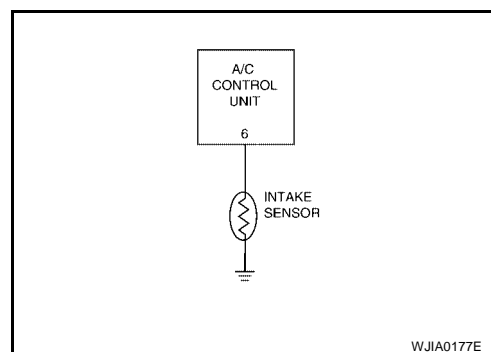

1. CHECK INTAKE SENSOR CIRCUIT BETWEEN INTAKE SENSOR AND BODY GROUND

Disconnect intake sensor harness connector.

Terminals		Continuity
(+)	(-)	
Connector	Terminal No. (Wire color)	Body ground
M49	2 (B)	Yes

OK or NG

OK >> GO TO 2.

NG >> Repair harness or connector.

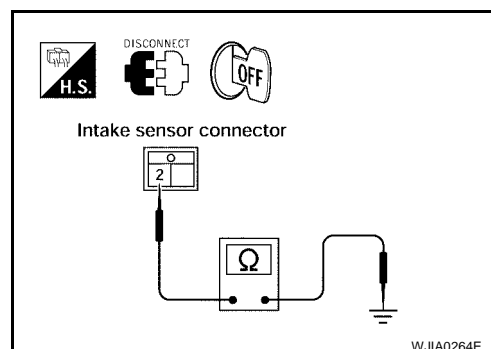

INTAKE SENSOR

2. CHECK INTAKE SENSOR CIRCUIT BETWEEN INTAKE SENSOR AND A/C CONTROL UNIT

Disconnect A/C control unit harness connector.

Terminals				Continuity
(+)		(-)		
Connector	Terminal No. (Wire color)	Connector	Terminal No. (Wire color)	Yes
M49	1 (GY)	M32	12 (GY)	

OK or NG

OK >> GO TO 3.

NG >> Repair harness or connector.

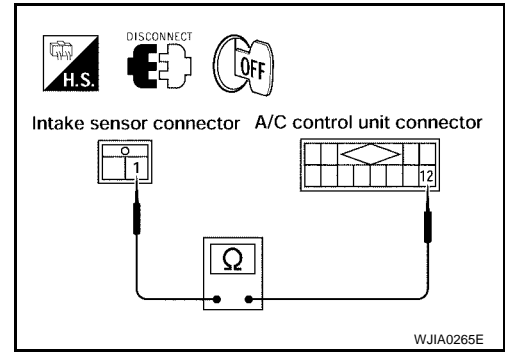

3. CHECK INTAKE SENSOR

Refer to [MTC-66, "Intake Sensor Circuit"](#) .

OK or NG

OK >> Replace A/C control unit.

NG >> Replace intake sensor.

Removal and Installation

1. Remove the evaporator. Refer to [MTC-80, "Removal"](#) .
2. Remove the intake sensor clip and then the sensor.

CAUTION:

Be careful not to damage the core surface.

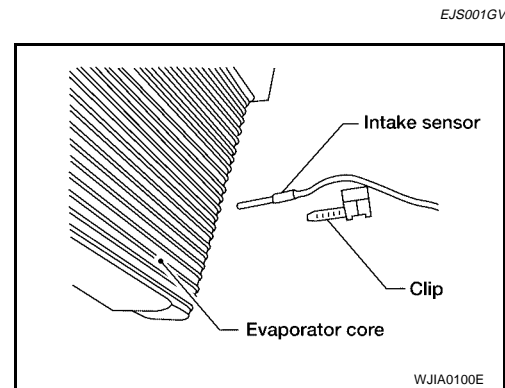

COMPRESSOR

COMPRESSOR

PFP:92600

Removal and Installation

EJS001BD

SEC. 274 • 275
QG18DE

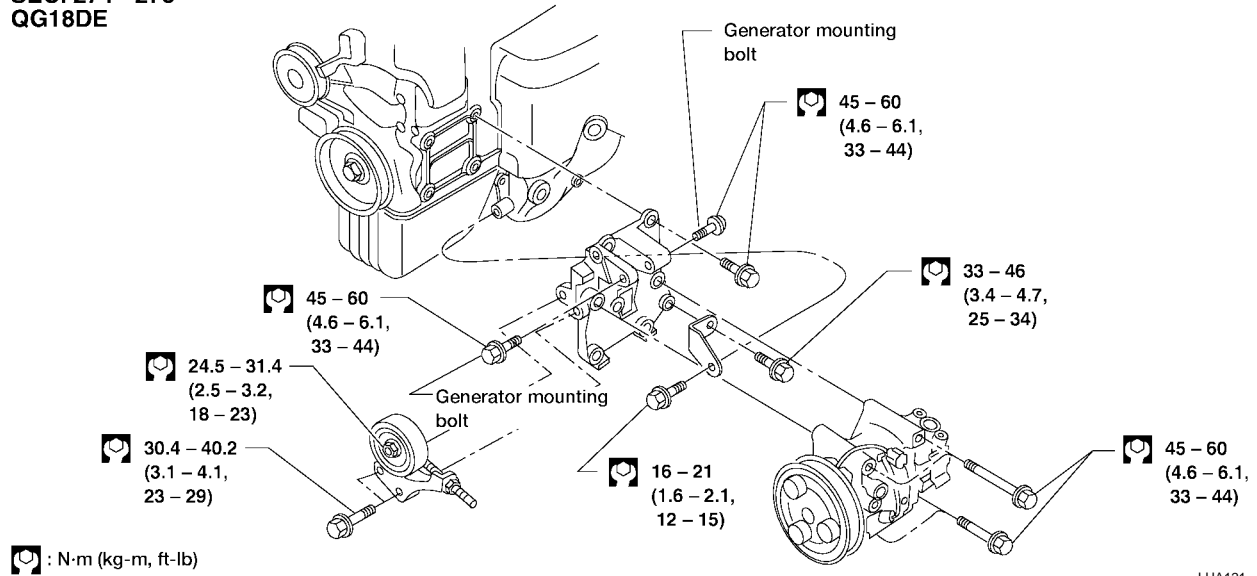

LHA121

SEC. 274•275
QR25DE

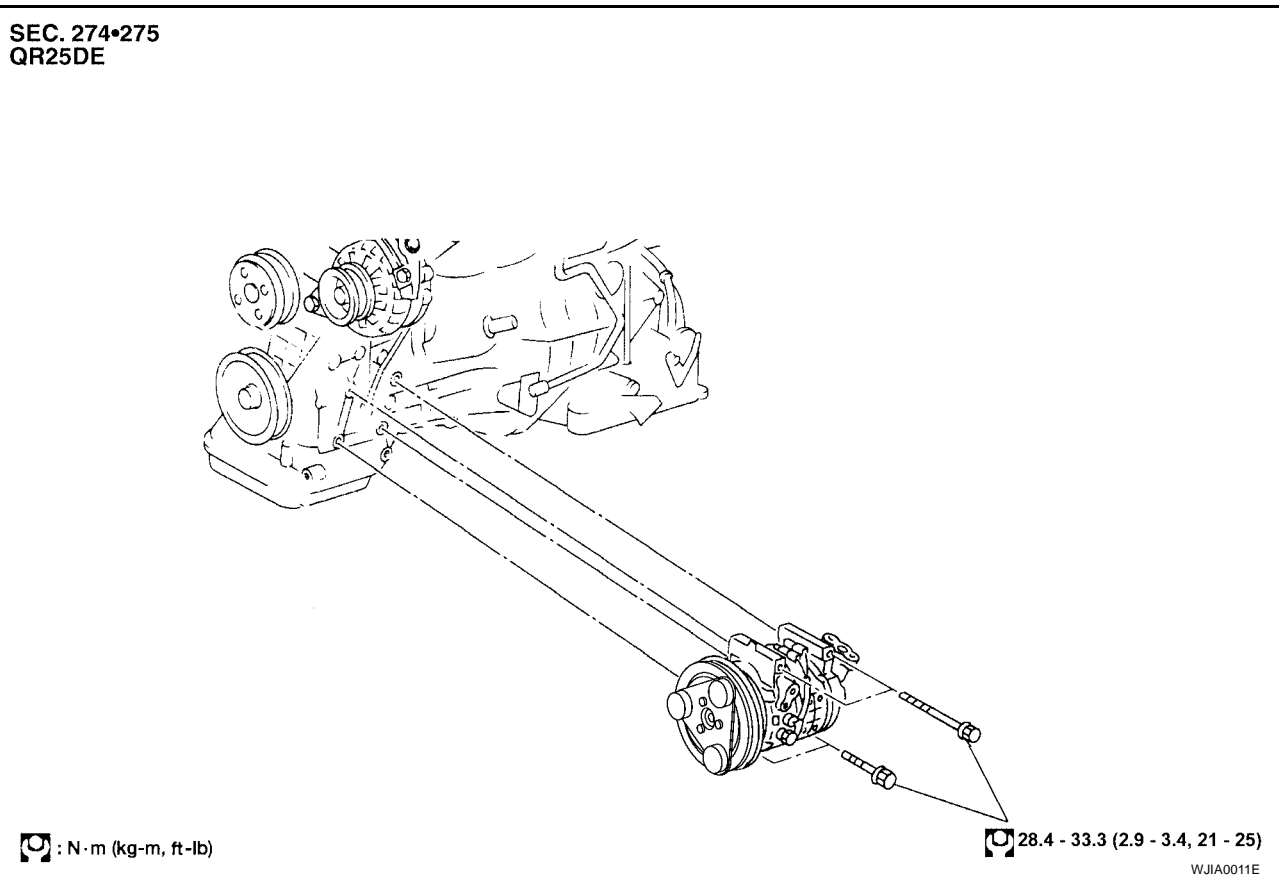

WJIA0011E

COMPRESSOR CLUTCH

COMPRESSOR CLUTCH

PFP:92600

Overhaul QG18DE

EJS001BE

A
B
C
D
E
F
G

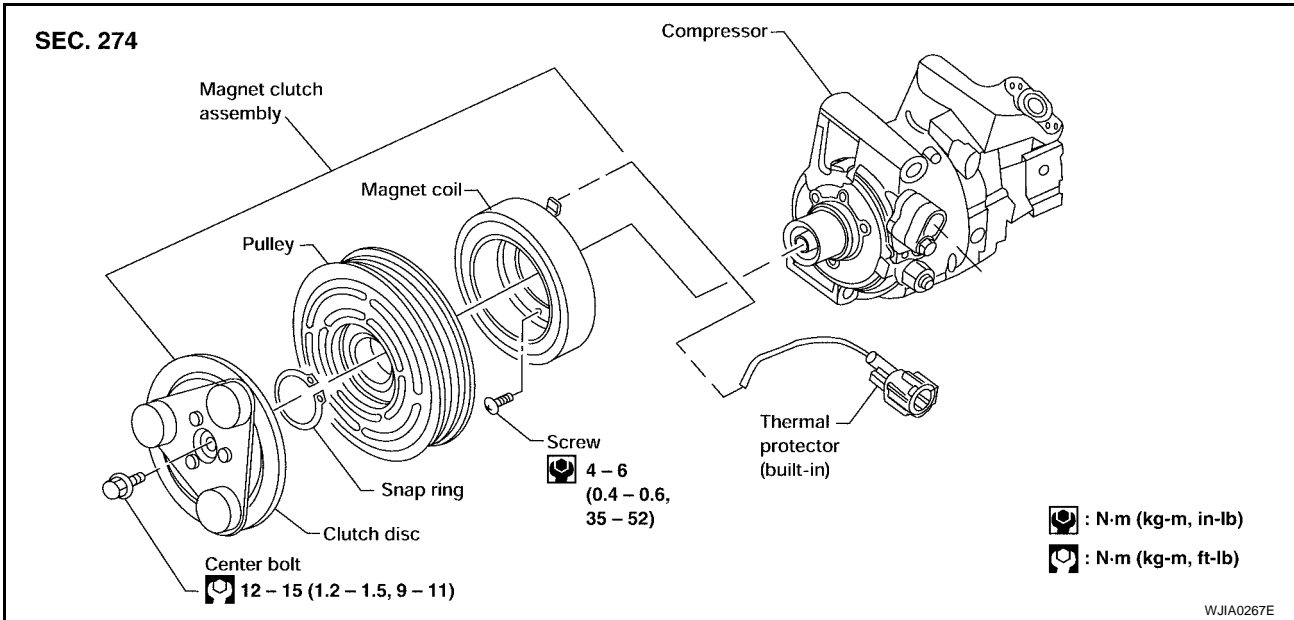

QR25DE

H
I

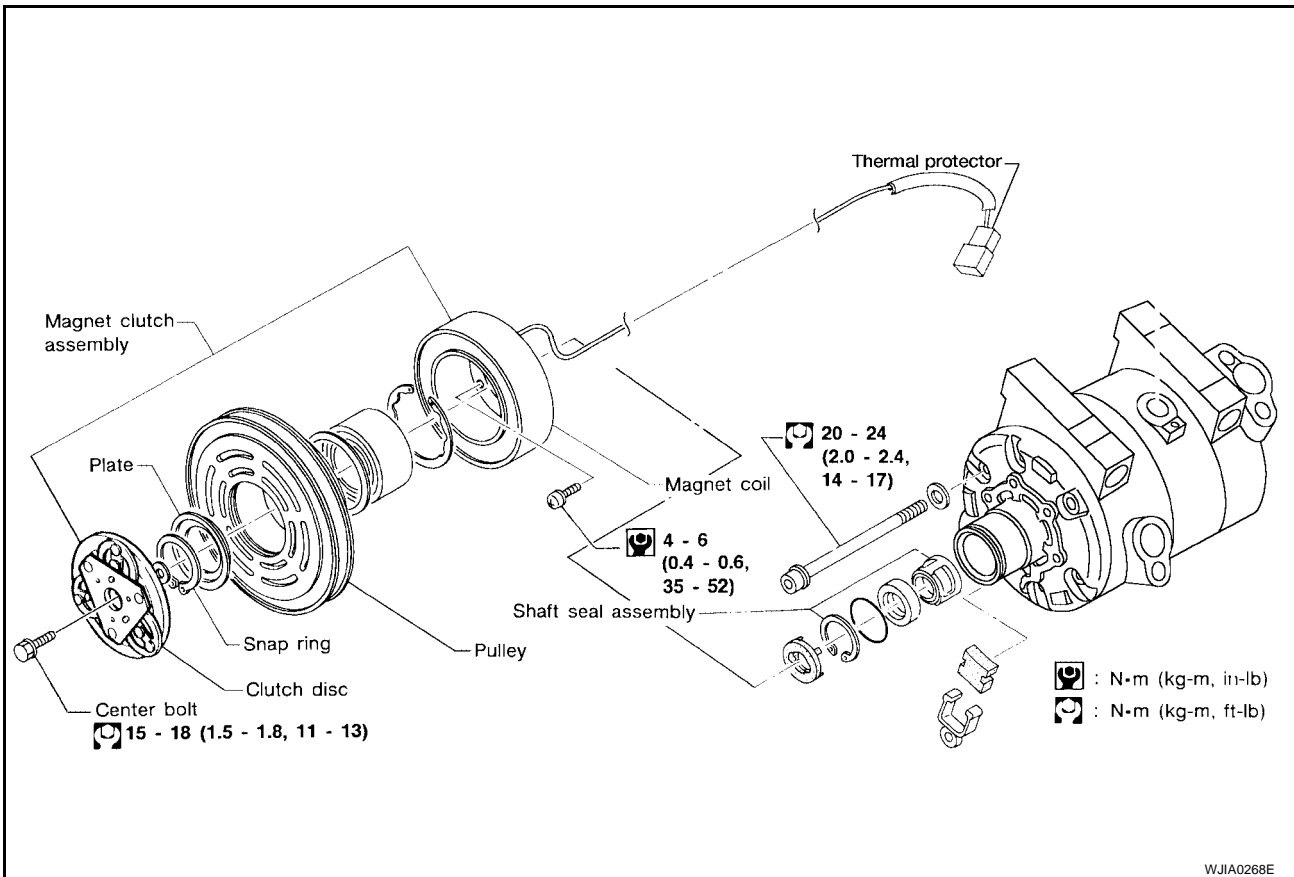

MTC

K
L
M

COMPRESSOR CLUTCH

EJS001BF

Removal QG18DE

- When removing center bolt, hold clutch disc with clutch disc tool.
- Remove the clutch disc.
Clutch disc holding tool:
(J-44614) Commercial service tool

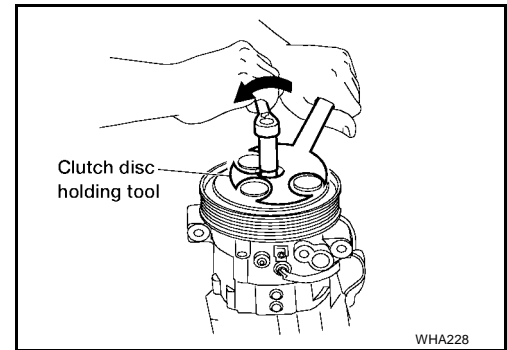

- Remove the snap ring using external snap ring pliers.

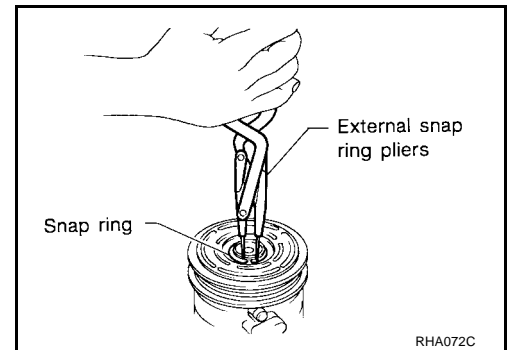

- Pulley removal:

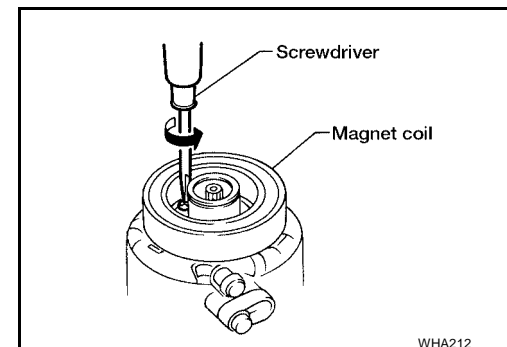
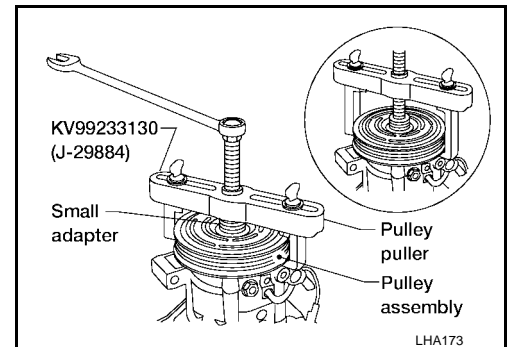

Use a pulley puller with small adapter. Position the small adapter on the end of the drive shaft and the center of the puller on the small adapter. Remove the pulley assembly with the puller.

To prevent deformation of the pulley groove, the puller claws should be hooked under (not into) the pulley groove.

- Remove the snap ring using external snap ring pliers.
- Remove the magnet coil harness clip using a screwdriver, the three magnet coil fixing screws and remove the magnet coil.

COMPRESSOR CLUTCH

QR25DE

- When removing center bolt, hold clutch disc with clutch disc tool.
- Remove the drive plate using the clutch disc puller. Insert the holder's three pins into the drive plate. Rotate the holder clockwise to hook it onto the plate. Then tighten the center bolt to remove the drive plate. While tightening the center bolt, insert a round bar (screwdriver, etc.) between two of the pins (as shown in the figure) to prevent drive plate rotation. After removing the drive plate, remove the shims from either the drive shaft or the drive plate.

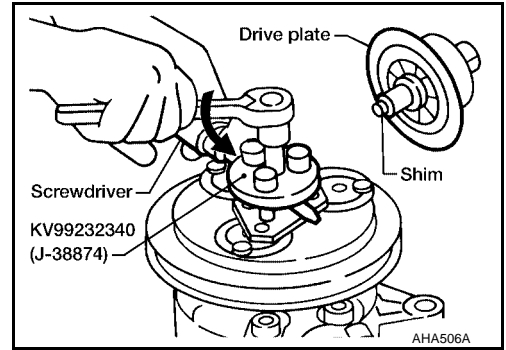
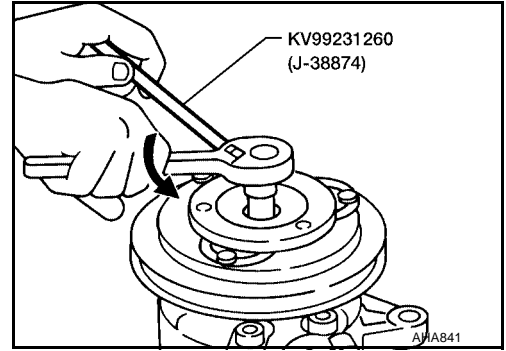

- Remove the snap ring using external snap ring pliers.

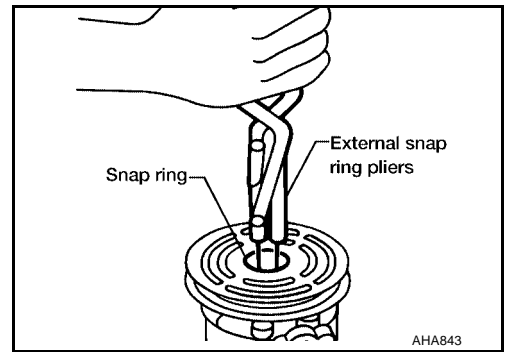

- For pulley removal, use pulley puller. Use a commercially available pulley puller. Position the center of the puller on the end of the drive shaft. Remove the pulley assembly with the puller. **To prevent deformation of the pulley groove, the puller claws should be hooked under (not into) the pulley groove.**
- Remove the field coil harness clip using a screwdriver.

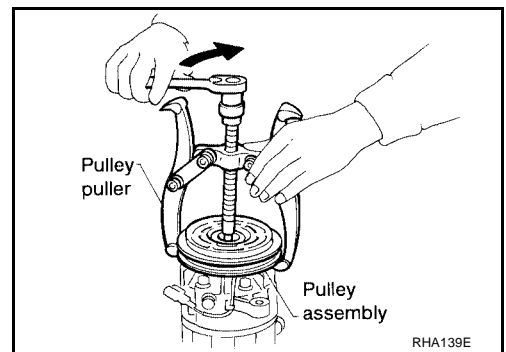

A
B
C
D
E
F
G
H
I
MTC
K
L
M

COMPRESSOR CLUTCH

- Remove the three field coil fixing screws and remove the field coil.

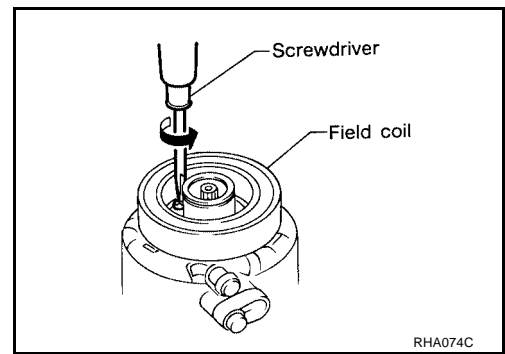

EJS001BG

Inspection CLUTCH DISC

If the contact surface shows signs of damage due to excessive heat, replace clutch disc and pulley.

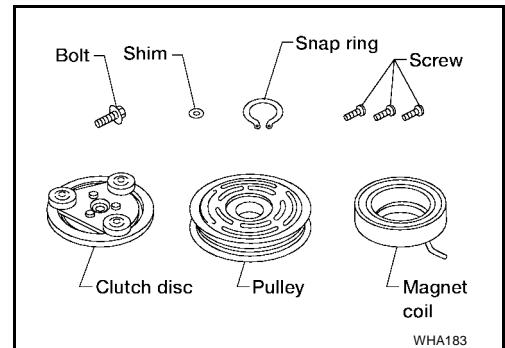

PULLEY

Check the appearance of the pulley assembly. If contact surface of pulley shows signs of excessive grooving, replace clutch disc and pulley. The contact surfaces of the pulley assembly should be cleaned with a suitable solvent before reinstallation.

COIL

Check magnet coil for loose connection or cracked insulation.

Installation QG18DE

EJS001BH

- Install the magnet coil.
Be sure to align the magnet coil pin with the hole in the compressor front head.
- Install the magnet coil harness clip using a screwdriver.

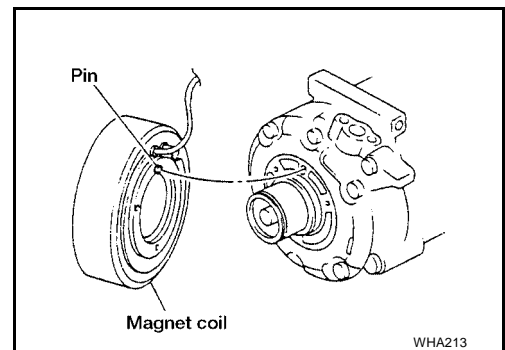

- Install the pulley assembly using the installer and a wrench, and then install the snap ring using snap ring pliers.

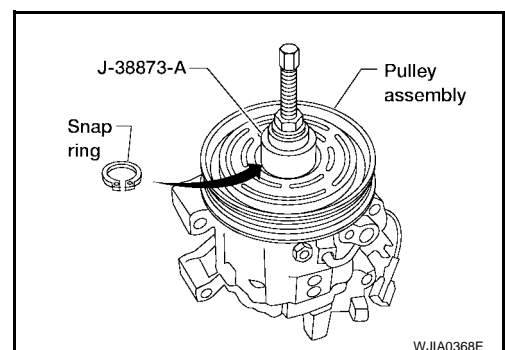

COMPRESSOR CLUTCH

- Install the clutch disc on the drive shaft, together with the original shim(s). Press the clutch disc down using the drive plate installer.

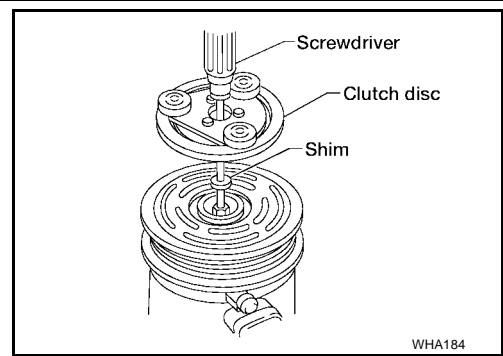

- Using the clutch disc tool to prevent clutch disc rotation, tighten the bolt to 12 to 15 N·m (1.2 to 1.5 kg·m, 9 to 11 ft·lb) torque.
- **After tightening the bolt, check that the pulley rotates smoothly.**

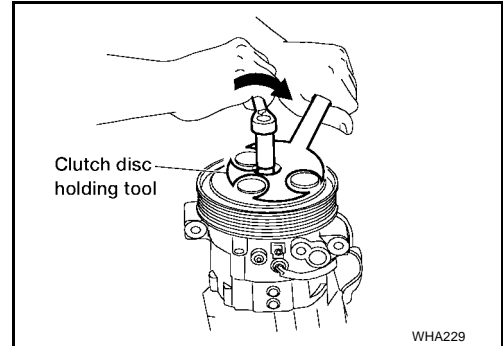

- Check clearance all the way around the clutch disc.

Clutch disc-to-pulley : 0.3 - 0.6 mm (0.012 - 0.024 in) clearance

If the specified clearance is not obtained, replace adjusting spacer and readjust.

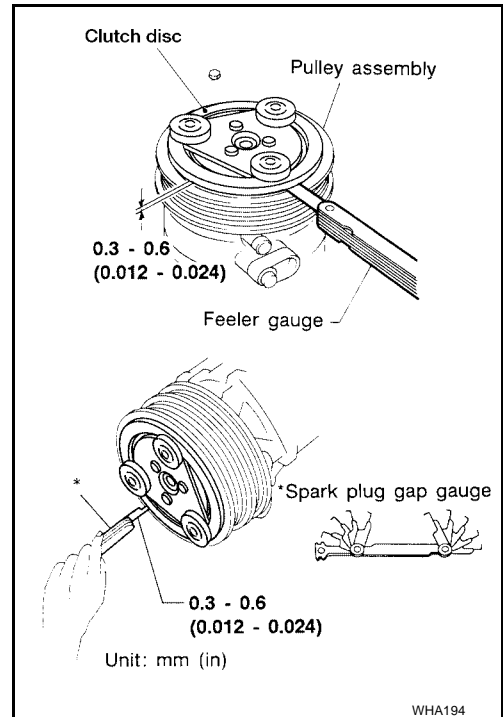

A
B
C
D
E
F
G
H
I
MTC
K
L
M

COMPRESSOR CLUTCH

QR25DE

- Install the field coil.
Be sure to align the magnet coil pin with the hole in the compressor front head.
- Install the magnet coil harness clip using a screwdriver.

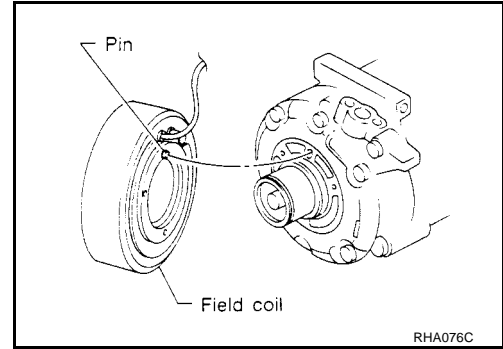

- Install the pulley assembly using the installer, and then install the snap ring using snap ring pliers.

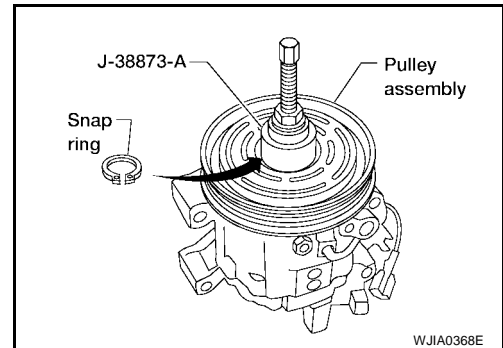

- Install the drive plate on the drive shaft, together with the original shim(s). Press the drive plate down with the installer.

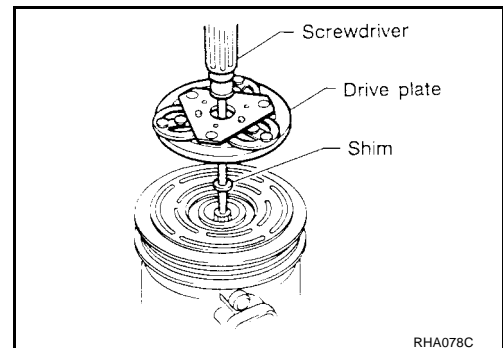

- Using the holder to prevent clutch disc rotation, tighten the bolt to 12 to 15 N-m (1.2 to 1.5 kg-m, 9 to 11 ft-lb) torque.
- **After tightening the bolt, check that the pulley rotates smoothly.**

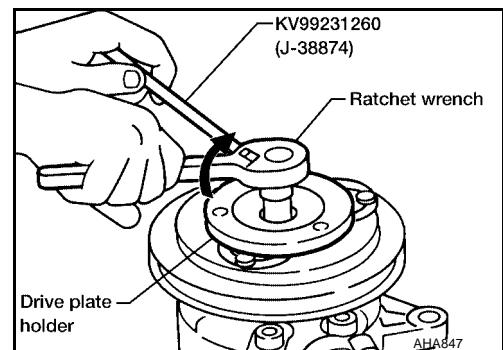

COMPRESSOR CLUTCH

- Check clearance all the way around the clutch disc.

Clutch disc-to-pulley clearance : 0.3 - 0.6 mm (0.012 - 0.024 in)

If the specified clearance is not obtained, replace adjusting spacer and readjust.

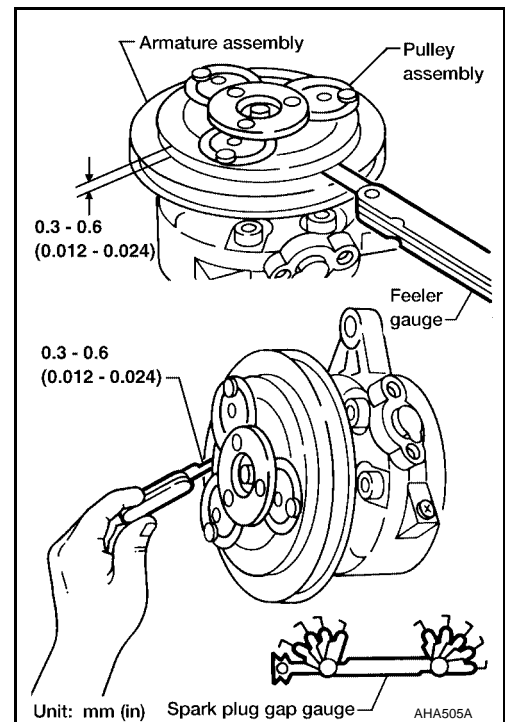

Break-In Operation

When replacing compressor clutch assembly, always conduct the break-in operation. This is done by engaging and disengaging the clutch about 30 times. Break-in operation raises the level of transmitted torque.

A
B
C
D
E
F
G
H
I

MTC

K
L
M

THERMAL PROTECTOR

THERMAL PROTECTOR

PF2:27631

Inspection

EJS001BJ

- Check continuity between terminal and ground.

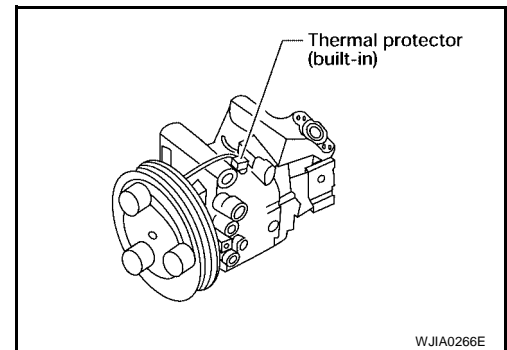

IN-CABIN MICROFILTER

PFP:27277

EJS001GX

IN-CABIN MICROFILTER

Removal and Installation FUNCTION

Air inside passenger compartment is kept clean at either recirculation or fresh mode by installing in-cabin microfilter into blower unit.

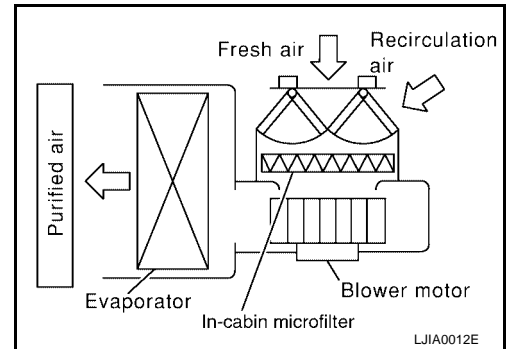

REPLACEMENT TIMING

Refer to [MA-7, "Schedule 1"](#) or [MA-11, "Schedule 2"](#).
Caution label is affixed inside the glove box.

REPLACEMENT PROCEDURES

1. Remove glove box assembly. Refer to [IP-10, "Removal and Installation"](#).
2. Remove in-cabin microfilter cover.
3. Remove the in-cabin microfilter from blower unit.
4. Replace with new in-cabin microfilter and reinstall cover on blower unit.
5. Reinstall glove box assembly.

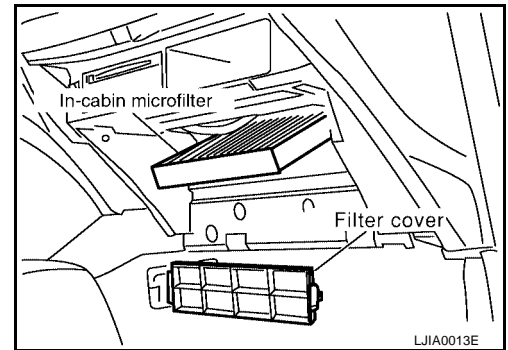

A

B

C

D

E

F

G

H

I

MTC

K

L

M

HEATER & COOLING UNIT (HEATER CORE)

HEATER & COOLING UNIT (HEATER CORE)

PF27110

Removal

EJS001BK

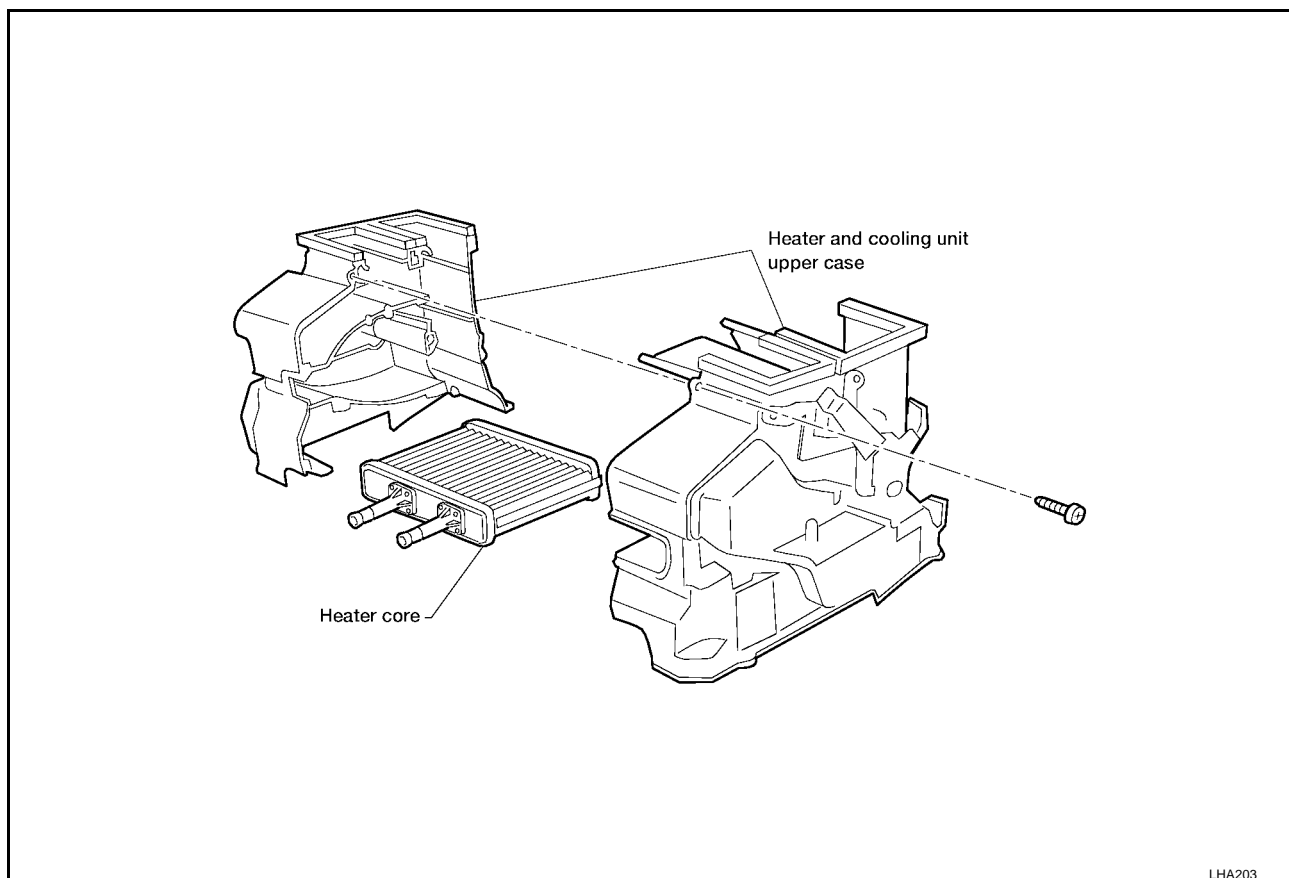

1. Drain the cooling system. Refer to [MA-16, "DRAINING ENGINE COOLANT"](#) (QG18DE), or [MA-23, "DRAINING ENGINE COOLANT"](#) (QR25DE).
2. Discharge the A/C system. Refer to [MTC-82, "Discharging Refrigerant"](#) .
3. Disconnect the two heater hoses from inside the engine compartment.
4. Remove the instrument panel assembly and steering member assembly. Refer to [IP-10, "INSTRUMENT PANEL ASSEMBLY"](#) .
5. Remove the heater unit.
6. Remove the heater core.

Installation

EJS001BL

Install in the reverse order of removal.

When filling radiator with coolant, refer to [MA-16, "DRAINING ENGINE COOLANT"](#) (QG18DE), or [MA-23, "DRAINING ENGINE COOLANT"](#) (QR25DE).

Recharge the A/C system. Refer to [MTC-82, "Evacuating System and Charging Refrigerant"](#) .

BLOWER UNIT

PFP:27200

EJS001BM

BLOWER UNIT

Removal

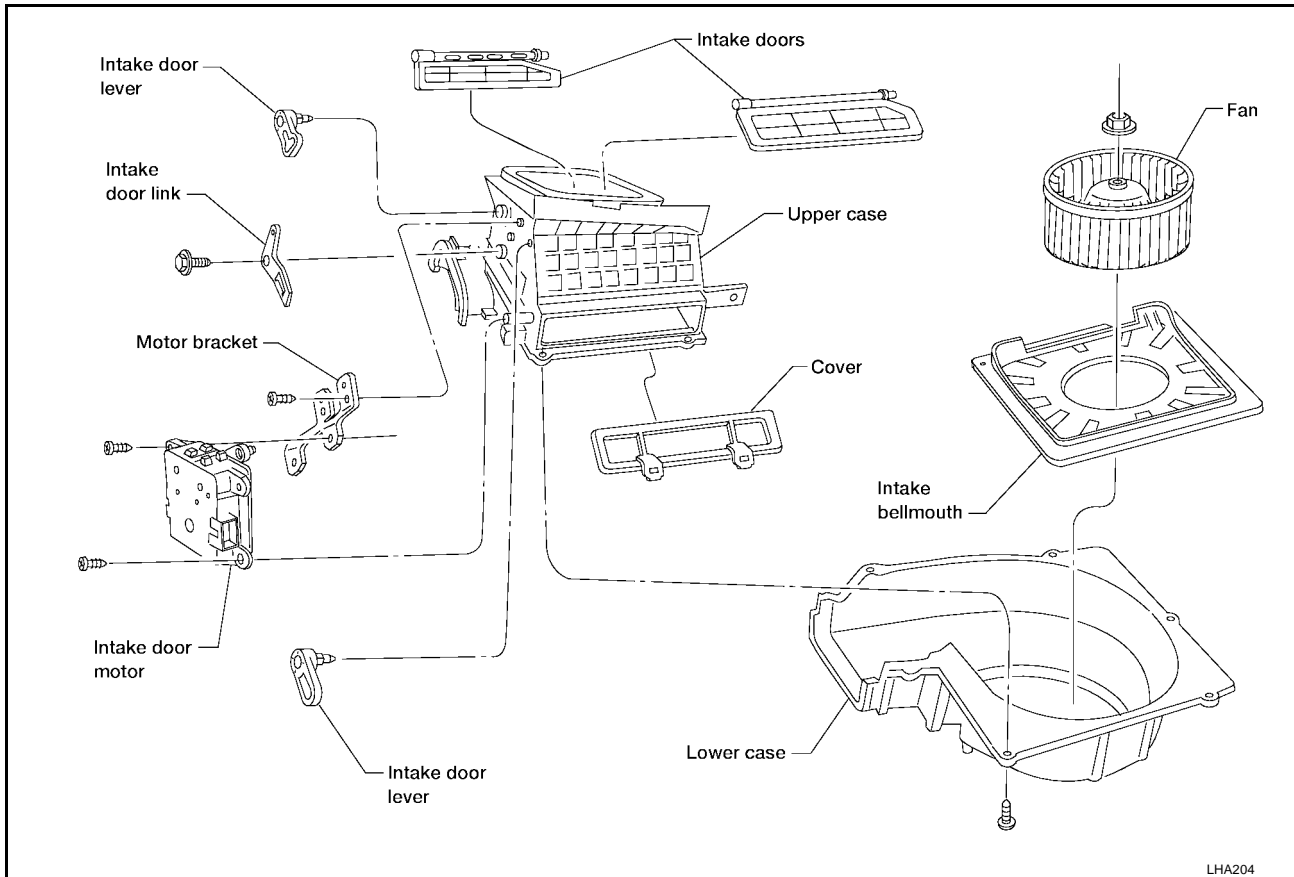

1. Discharge the A/C system. Refer to [MTC-82, "Discharging Refrigerant"](#).
2. Disconnect the two refrigerant lines from the engine compartment. Cap the A/C lines to prevent moisture from entering the system.
3. Remove the glove box and mating trim. Refer to [IP-10, "Removal and Installation"](#).
4. Remove cooling unit. Refer to [MTC-80, "Removal"](#).
5. Disconnect the resistor and blower motor connector.
6. Remove blower unit.
7. Remove the three bolts and then remove the motor from the blower case.

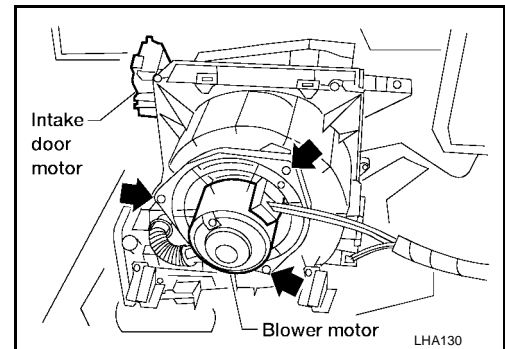

Installation

EJS001BN

Install in the reverse order of removal.

Recharge the A/C system. Refer to [MTC-82, "Evacuating System and Charging Refrigerant"](#).

A

B

C

D

E

F

G

H

I

MTC

K

L

M

A/C EVAPORATOR

A/C EVAPORATOR

PFP:27280

Removal

EJS001B0

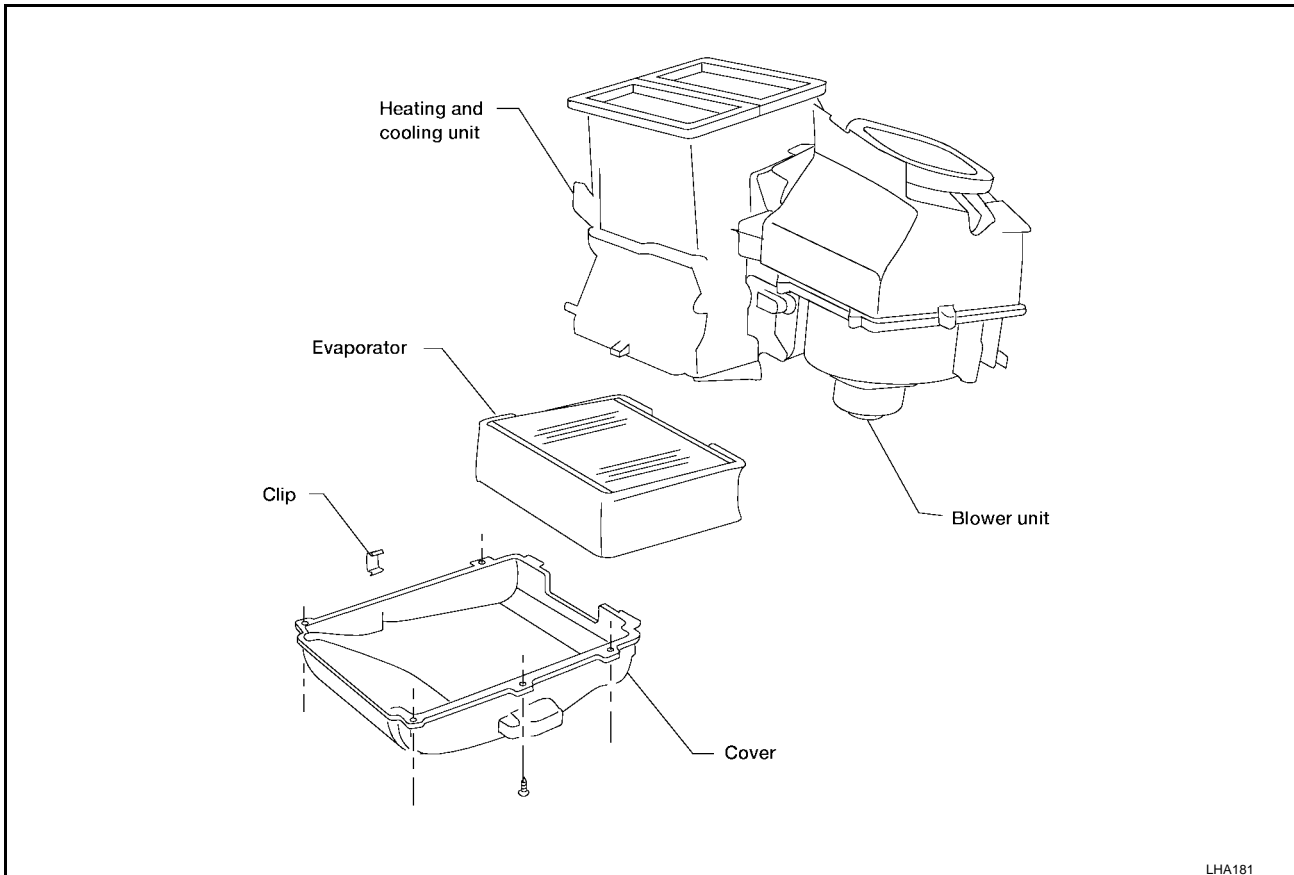

LHA181

1. Discharge the A/C system. Refer to [MTC-82, "Discharging Refrigerant"](#).
2. Remove clamp bolt and remove low-pressure and high-pressure lines from cooling unit (expansion valve). Remove lines from retaining clip on dash panel and move lines away from dash panel for clearance.
3. Install caps over cooling unit (expansion valve) ports and lines.
4. Remove both side front console side covers.
5. Remove passenger side instrument panel lower cover and left lower instrument cover clip (from blower case).
6. Remove center console.
7. Remove instrument stay assemblies LH and RH.
8. Remove floor air duct risers on the right and left sides of the console front brackets (if equipped).
9. Disconnect cooling unit drain hose from lower cooling unit cover.
10. Remove five screws and clip from heating and cooling unit lower cover.
11. Drop lower cover as far as possible, reach inside of case and slide evaporator core rearward away from dash panel as far as possible so that rear of evaporator core slides up on case retaining tabs. Evaporator core may be pushed from engine compartment to ease movement. (This provides clearance at the front of the unit so that the cover can be removed).
12. Remove lower cover.

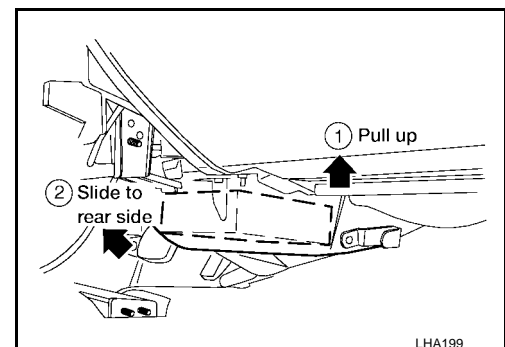

LHA199

A/C EVAPORATOR

13. Mark installation point of intake sensor and remove intake sensor from evaporator core.
14. Remove evaporator core from case by sliding forward off of case retaining tabs.
15. Remove expansion valve from evaporator core (if necessary).

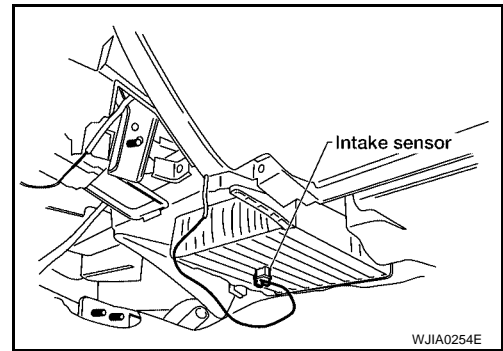

EJS001BP

Installation

Installation is the reverse of removal*.

Recharge the A/C system. Refer to [MTC-82, "Evacuating System and Charging Refrigerant"](#).

*: When installing lower cover to cooling unit case, ensure that the thermo probe is in the same location as originally installed, and that the intake sensor wire is properly positioned in case slot.

NOTE:

Be sure that the evaporator core is fully seated against the dash panel before securing lower cover.

A
B
C
D
E
F
G
H
I
K
L
M

MTC

REFRIGERANT LINES

PF9:92600

EJS001BQ

REFRIGERANT LINES

HFC-134a (R-134a) Service Procedure SETTING OF SERVICE TOOLS AND EQUIPMENT

Discharging Refrigerant

WARNING:

Avoid breathing A/C refrigerant and lubricant vapor or mist. Exposure may irritate eyes, nose and throat. Remove HFC-134a (R-134a) from A/C system using certified service equipment meeting requirements of SAE J2210 (R-134a recycling equipment) or J2209 (R-134a recovery equipment). If accidental system discharge occurs, ventilate work area before resuming service. Additional health and safety information may be obtained from refrigerant and lubricant manufacturers.

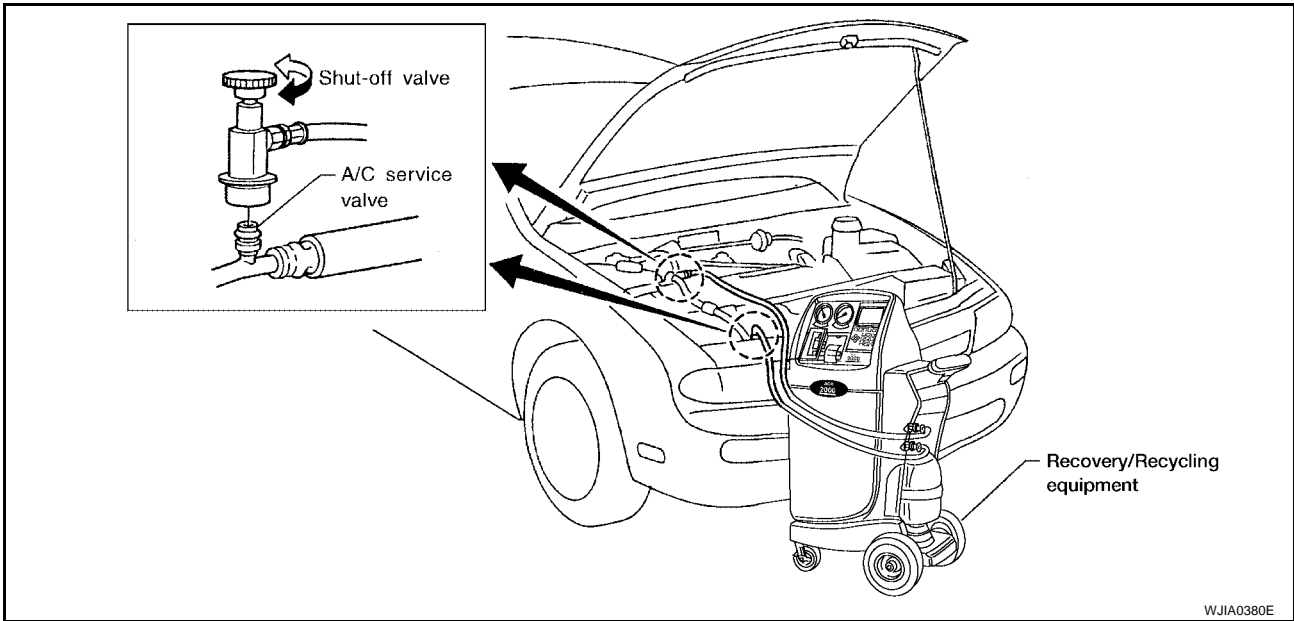

Evacuating System and Charging Refrigerant

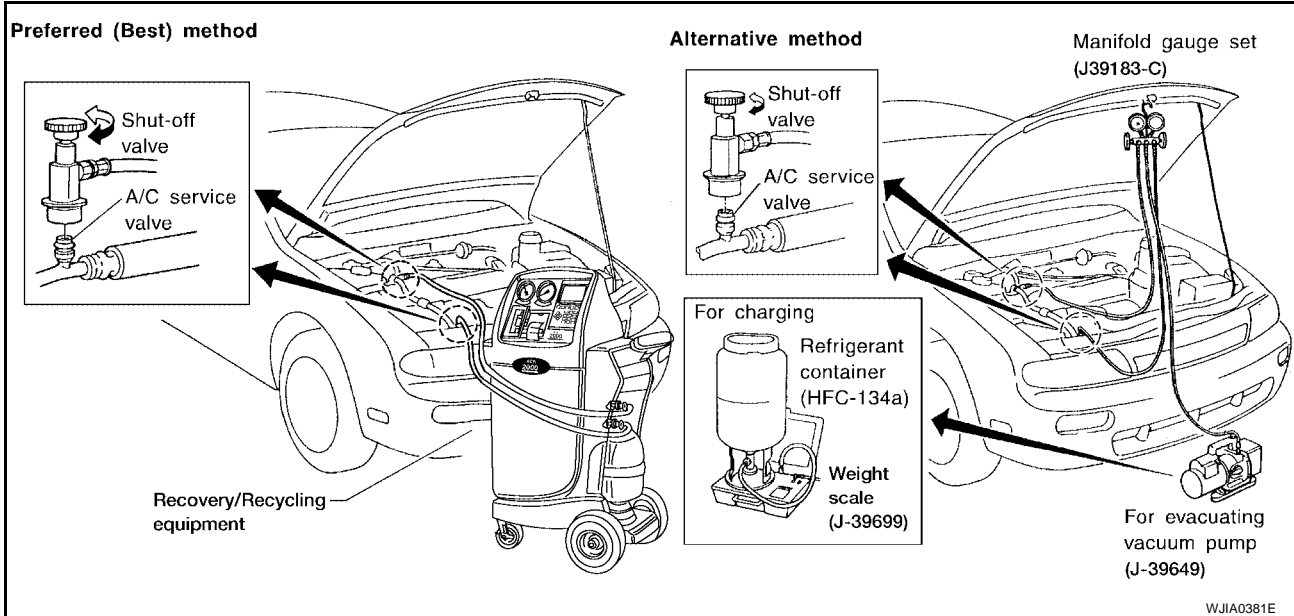

REFRIGERANT LINES

Recovered lubricant. Refer to "CHECKING AND ADJUSTING", *1.

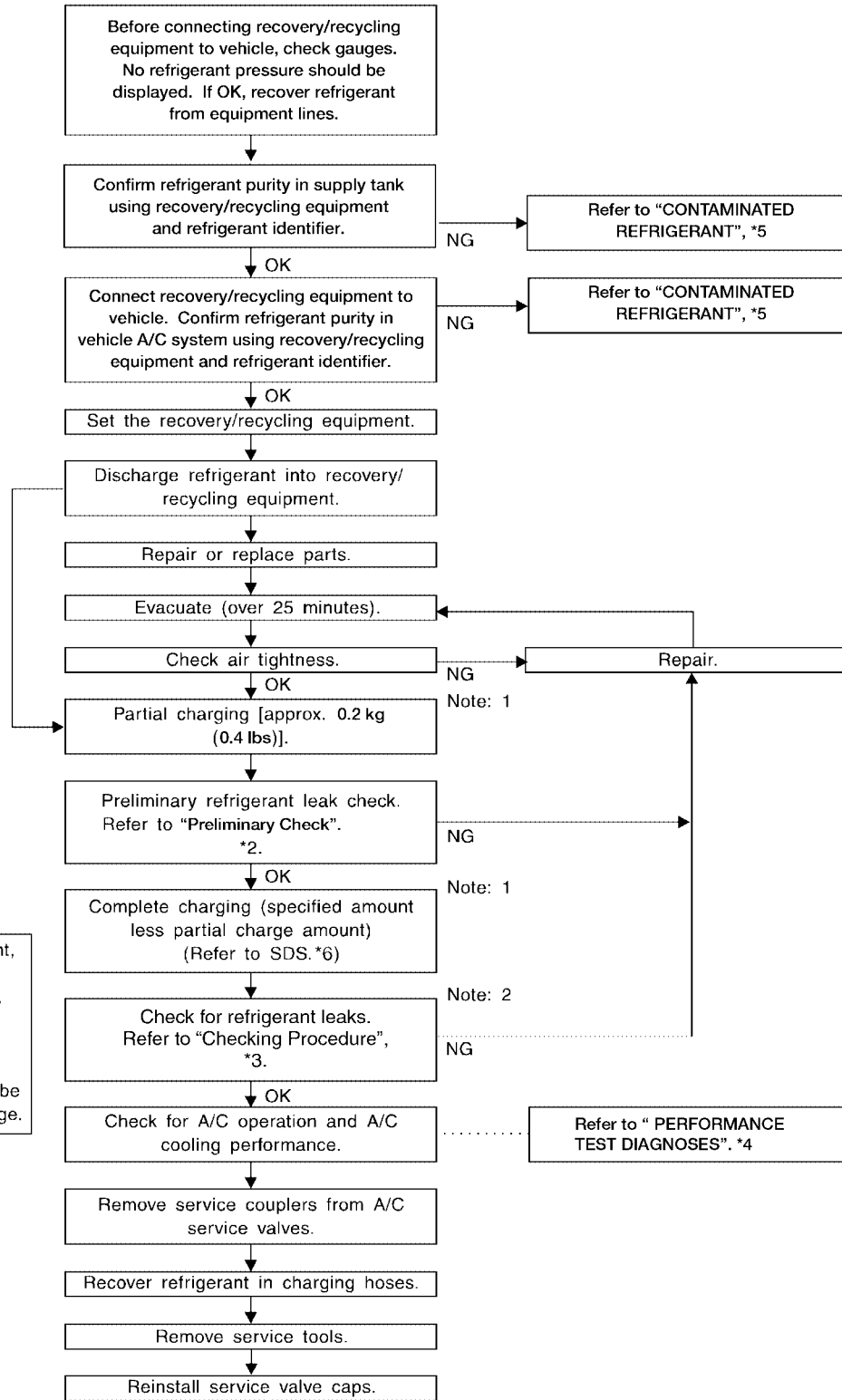

Note: 1 Before charging refrigerant, ensure engine is off.
 Note: 2 Before checking for leaks, start engine to activate air conditioning system then turn engine off. Service valve caps must be installed to prevent leakage.

*1 [MTC-16](#)
 *4 [MTC-58](#)

*2 [MTC-86](#)
 *5 [MTC-3](#)

*3 [MTC-87](#)
 *6 [MTC-91](#)

WJIA0382E

REFRIGERANT LINES

EJS001BR

Removal and Installation

- Refer to [MTC-5, "Precautions for Refrigerant Connection"](#).

QG18DE

SEC. 271 • 274 • 276

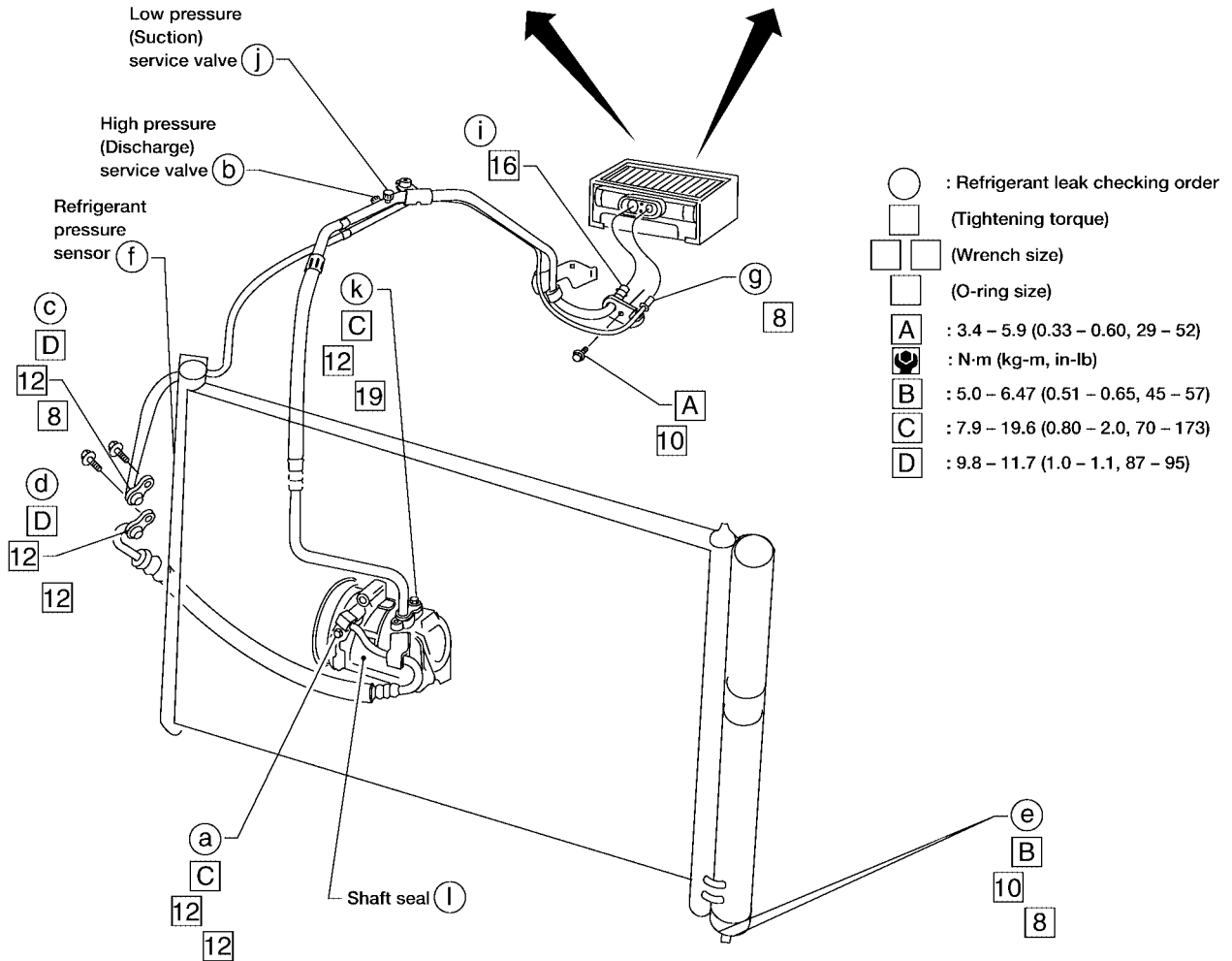
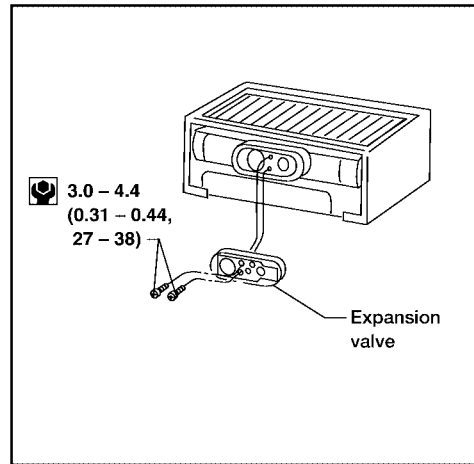
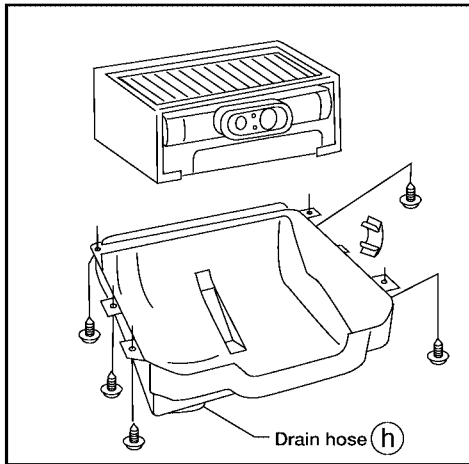

WJIA0420E

REFRIGERANT LINES

QR25DE

SEC. 271 • 274 • 276

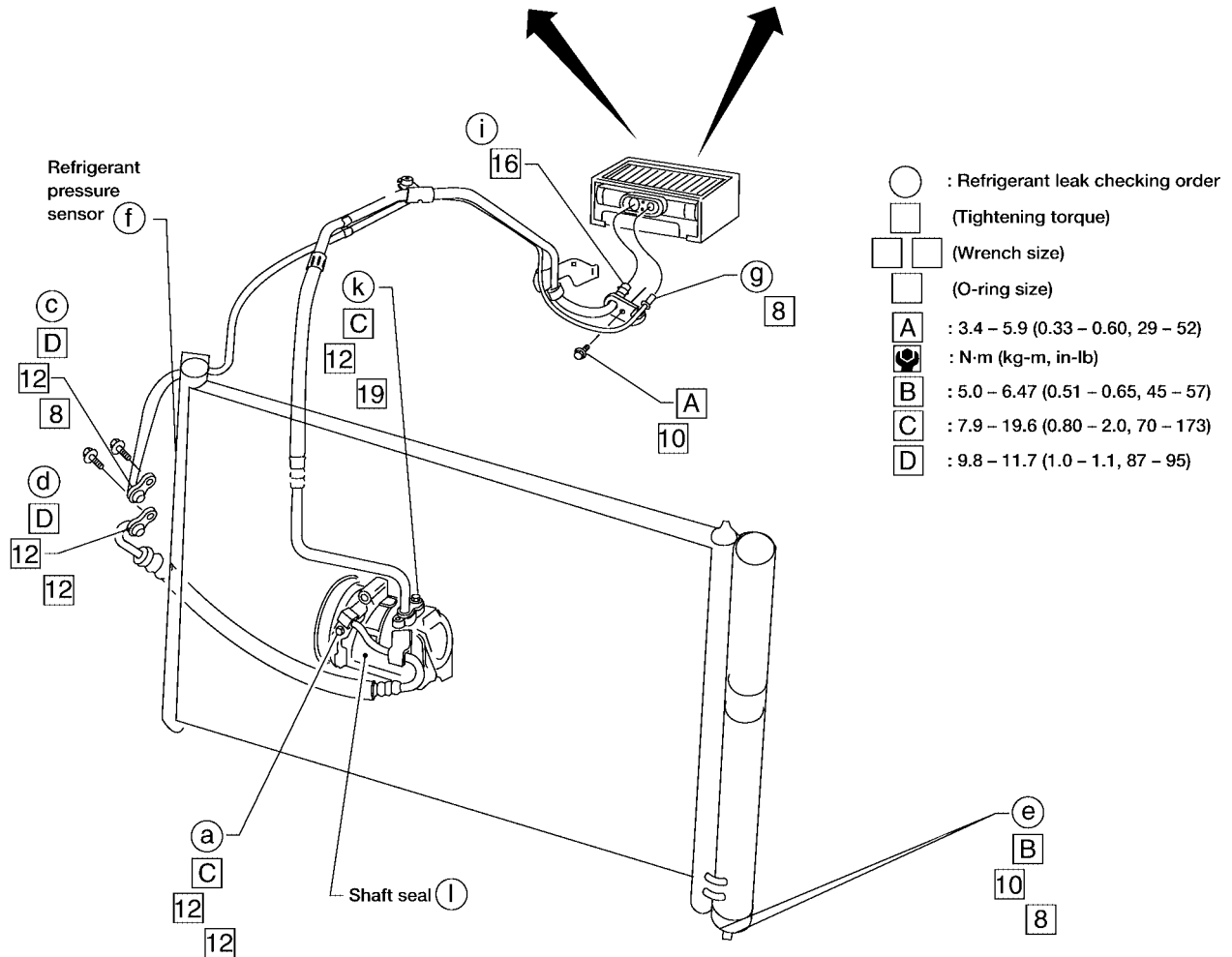
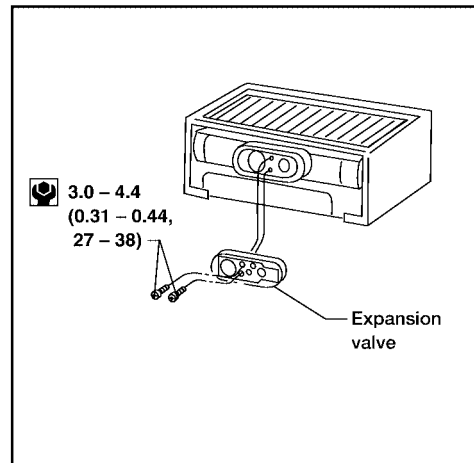
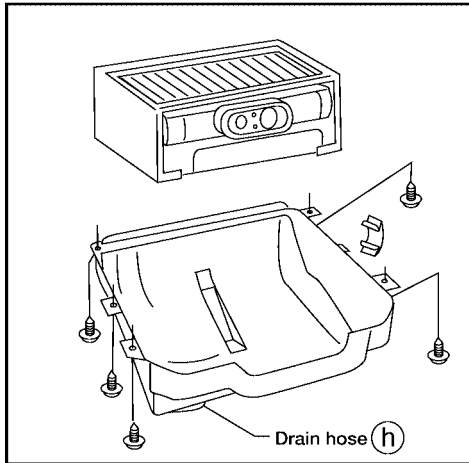

A
B
C
D
E
F
G
H
I
MTC
K
L
M

WJIA0421E

REFRIGERANT LINES

EJS001BS

Checking Refrigerant Leaks PRELIMINARY CHECK

- Perform a visual inspection of all refrigeration parts, fittings, hoses and components for signs of A/C lubricant leakage, damage and corrosion. A/C lubricant leakage may indicate an area of refrigerant leakage. Allow extra inspection time in these areas when using either an electronic refrigerant leak detector or fluorescent dye leak detector.
- If dye is observed, confirm the leak with an approved electronic refrigerant leak detector. It is possible a prior leak was repaired and not properly cleaned.
- When searching for leaks, do not stop when one leak is found but continue to check for additional leaks at all system components and connections.
- When searching for refrigerant leaks using an electronic leak detector, move the probe along the suspected leak area at 25 - 50 mm (1 - 2 in) per second and no further than 1/4 inch from the component.

NOTE:

Moving the electronic leak detector probe slower and closer to the suspected leak area will improve the chances of finding a leak.

Electronic Refrigerant Leak Detector PRECAUTIONS FOR HANDLING LEAK DETECTOR

EJS001BT

When performing a refrigerant leak check, use a J-41995 electronic refrigerant leak detector or equivalent. Ensure that the instrument is calibrated and set properly per the operating instructions. The leak detector is a delicate device. In order to use the leak detector properly, read the operating instructions and perform any specified maintenance.

- **Other gases in the work area or substances on the A/C components, for example, anti-freeze, windshield washer fluid, solvents and lubricants, may falsely trigger the leak detector. Make sure the surfaces to be checked are clean. Clean with a dry cloth or blow off with shop air.**
 - **Do not allow the sensor tip of the detector to contact with any substance. This can also cause false readings and may damage the detector.**
1. Position probe approximately 5 mm (3/16 in) away from point to be checked.

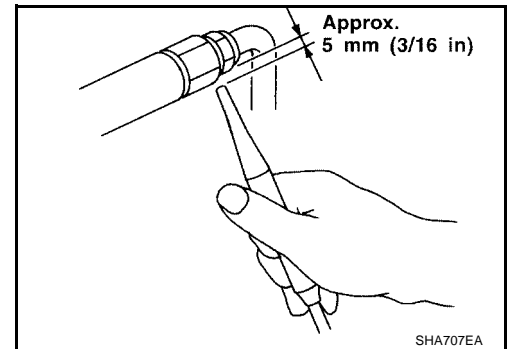
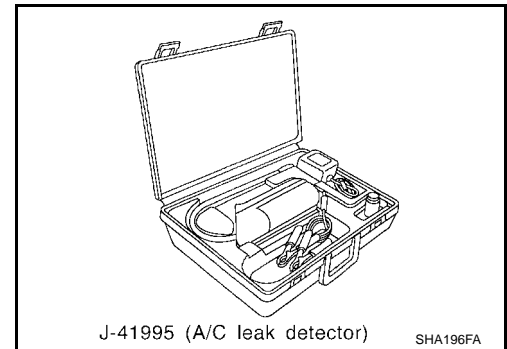

2. When testing, circle each fitting completely with probe.

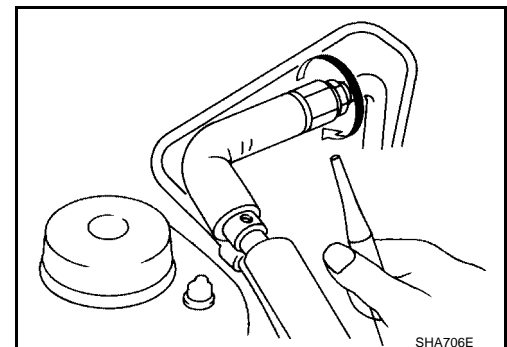

REFRIGERANT LINES

3. Move probe along component approximately 25 to 50 mm (1 to 2 in)/sec.

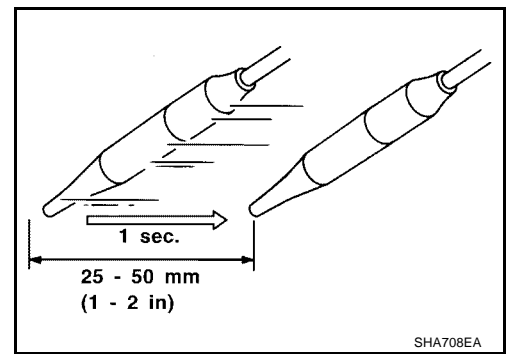

CHECKING PROCEDURE

To prevent inaccurate or false readings, make sure there is no refrigerant vapor, shop chemicals, or cigarette smoke in the vicinity of the vehicle. Perform the leak test in calm area (low air/wind movement) so that the leaking refrigerant is not dispersed.

1. Turn engine off.
2. Connect a suitable A/C manifold gauge set to the A/C service ports.
3. Check if the A/C refrigerant pressure is at least 345 kPa (3.52 kg/cm², 50 psi) above 16°C (61°F). If less than specification, recover/evacuate and recharge the system with the specified amount of refrigerant. Refer to [MTC-82, "HFC-134a \(R-134a\) Service Procedure"](#).

NOTE:

At temperatures below 16°C (61°F), leaks may not be detected since the system may not reach 345 kPa (3.52 kg/cm², 50 psi).

4. Conduct the leak test from the high side (compressor discharge **a** to evaporator inlet **g**) to the low side (evaporator drain hose **g** to shaft seal **l**). Refer to [MTC-86, "Checking Refrigerant Leaks"](#). Perform a leak check for the following areas carefully. Clean the component to be checked and move the leak detector probe completely around the connection/component.

- **Compressor**

Check the fitting of high and low pressure hoses, relief valve and shaft seal.

- **Liquid tank**

Check the pressure switch, tube fitting, weld seams and the fusible plug mount.

- **Service valves**

Check all around the service valves. Ensure service valve caps are secured on the service valves (to prevent leaks).

NOTE:

After removing A/C manifold gauge set from service valves, wipe any residue from valves to prevent any false readings by leak detector.

- **Cooling unit (Evaporator)**

With engine OFF, turn blower fan on "High" for at least 15 seconds to dissipate any refrigerant trace in the cooling unit. Wait a minimum of 10 minutes accumulation time (refer to the manufacturer's recommended procedure for actual wait time) before inserting the leak detector probe into the drain hose. Keep the probe inserted for at least ten seconds. Use caution not to contaminate the probe tip with water or dirt that may be in the drain hose.

5. If a leak detector detects a leak, verify at least once by blowing compressed air into area of suspected leak, then repeat check as outlined above.
6. Do not stop when one leak is found. Continue to check for additional leaks at all system components. If no leaks are found, perform steps 7 - 10.
7. Start engine.
8. Set the heater A/C control as follows:
 1. A/C switch ON.
 2. Face mode
 3. Recirculation switch ON
 4. Max cold temperature
 5. Fan speed high

A
B
C
D
E
F
G
H
I

MTC

K
L
M

REFRIGERANT LINES

- Run engine at 1,500 rpm for at least 2 minutes.
- Turn engine off and perform leak check again following steps 4 through 6 above.

Refrigerant leaks should be checked immediately after stopping the engine. Begin with the leak detector at the compressor. The pressure on the high pressure side will gradually drop after refrigerant circulation stops and pressure on the low pressure side will gradually rise, as shown in the graph. Some leaks are more easily detected when pressure is high.

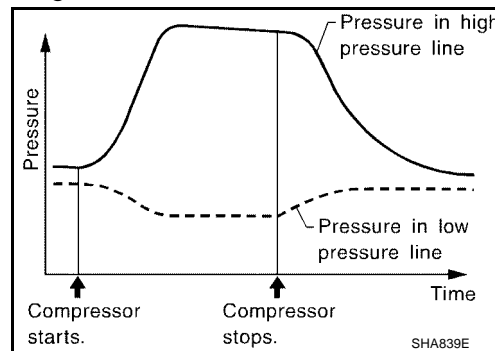

- Before connecting the recovery/recycling recharging equipment to the vehicle, check recovery/recycling recharging equipment gauges. No refrigerant pressure should be displayed. If pressure is displayed, recover refrigerant from equipment lines and then check refrigerant purity.
- Confirm refrigerant purity in supply tank using recovery/recycling recharging equipment and refrigerant identifier. Refer to [MTC-3, "Contaminated Refrigerant"](#).
- Confirm refrigerant purity in vehicle A/C system using recovery/recycling recharging equipment and refrigerant identifier. Refer to [MTC-3, "Contaminated Refrigerant"](#).
- Discharge A/C system using approved recovery/recycling equipment. Refer to [MTC-82, "Discharging Refrigerant"](#). Repair the leaking fitting or component as necessary.
- Evacuate and recharge A/C system. Refer to [MTC-82, "Evacuating System and Charging Refrigerant"](#). Perform the leak test to confirm no refrigerant leaks.
- Conduct A/C performance test to ensure system works properly.

Fluorescent Dye Leak Detector

EJS001BU

PRECAUTIONS FOR FLUORESCENT DYE LEAK DETECTION

- The fluorescent dye leak detector is not a replacement for an electronic refrigerant leak detector. The fluorescent dye leak detector should be used in conjunction with an electronic refrigerant leak detector (J-41995) to pinpoint refrigerant leaks.
- For your safety and your customer's satisfaction, read and follow all manufacturer's operating instructions and precautions prior to performing the work.
- Refer to [MTC-4, "Precautions for Leak Detection Dye"](#).

CHECKING SYSTEM FOR LEAKS USING THE FLUORESCENT LEAK DETECTOR

- Check A/C system for leaks using the UV lamp and safety glasses (J-42220) in a low sunlight area (area without windows preferable). Illuminate all components, fittings and lines. The dye will appear as a bright green/yellow area at the point of leakage. Fluorescent dye observed at the evaporator drain opening indicates an evaporator core assembly (tubes, core or expansion valve) leak.
- If the suspected area is difficult to see, use an adjustable mirror or wipe the area with a clean shop rag or cloth, then check the cloth with the UV lamp for dye residue.
- Confirm any suspected leaks with an approved electronic refrigerant leak detector.
- After the leak is repaired, remove any residual dye using dye cleaner (J-43872) to prevent future misdiagnosis.
- Perform a system performance check and verify the leak repair with an approved electronic refrigerant leak detector.

DYE INJECTION

(This procedure is only necessary when re-charging the system or when the compressor has seized and was replaced.)

Refer to [MTC-4, "Precautions for Leak Detection Dye"](#).

- Check A/C system static (at rest) pressure. Pressure must be at least 345 kPa (3.52 kg/cm², 50 psi).
- Pour one bottle (1/4 ounce / 7.4 cc) of the A/C refrigerant dye into the injector tool (J-41459).
- Connect the injector tool to the A/C LOW PRESSURE side service fitting.
- Start engine and switch A/C ON.

REFRIGERANT LINES

-
5. With the A/C operating (compressor running), inject one bottle (1/4 ounce / 7.4 cc) of fluorescent dye through the low-pressure service valve using dye injector tool J-41459 (refer to the manufacturer's operating instructions).
 6. With the engine still running, disconnect the injector tool from the service fitting.

CAUTION:

Be careful not to allow dye to spray or drip when disconnecting the injector from the system.

NOTE:

If repairing the A/C system or replacing a component, pour the dye directly into the open system connection and proceed with the service procedures.

7. Operate the A/C system for a minimum of 20 minutes to mix the dye with the system oil. Depending on the leak size, operating conditions and location of the leak, it may take from minutes to days for the dye to penetrate a leak and become visible.

A

B

C

D

E

F

G

H

I

MTC

K

L

M

BELT

BELT

PF9:92600

Tension Adjustment

EJS001BV

- Refer to [MA-16, "Checking Drive Belts"](#) (QG18DE) or [MA-23, "Checking Drive Belts"](#) (QR25DE).

SERVICE DATA AND SPECIFICATIONS (SDS)

SERVICE DATA AND SPECIFICATIONS (SDS)

PFP:00030

General Specifications COMPRESSOR

EJS001BX

Engine	QG18DE	QR25DE
Model	ZEXEL make DKV-11G	ZEXEL make DKV-14G
Type	Vane rotary	
Displacement cm ³ (cu in)/rev.	110 (6.71)	140 (8.54)
Direction of rotation	Clockwise (viewed from drive end)	
Drive belt	Poly V	

LUBRICANT

Name	NISSAN A/C System Lubricant Type R or equivalent	
Part number	KLH00-PAGR0	
Capacity mℓ (US fl oz, Imp fl oz)	Total in system	180 (6.1, 6.3)

REFRIGERANT

Type	HFC-134a (R-134a)
Capacity kg (lb)	0.45 - 0.55 (0.99 - 1.21)

Inspection and Adjustment

ENGINE IDLING SPEED (WHEN A/C IS ON)

EJS001BY

- Refer to [EC-35, "IDLE SPEED"](#) (QG18DE), or [EC-662, "IDLE SPEED"](#) (QR25DE).

BELT TENSION

- Refer to [MA-16, "Checking Drive Belts"](#) (QG18DE) or [MA-23, "Checking Drive Belts"](#) (QR25DE).

A

B

C

D

E

F

G

H

I

MTC

K

L

M

SERVICE DATA AND SPECIFICATIONS (SDS)
