

SECTION **FSU**
FRONT SUSPENSION

A
B
C
D

FSU

CONTENTS

PRECAUTIONS	2	Disassembly	9	F
Precautions	2	Inspection	9	
PREPARATION	3	SHOCK ABSORBER ASSEMBLY	9	
Special Service Tools	3	MOUNTING INSULATOR AND RUBBER PARTS..	10	G
Commercial Service Tools	3	THRUST BEARING	10	
NOISE, VIBRATION, AND HARSHNESS (NVH)		COIL SPRING	10	
TROUBLESHOOTING	4	Assembly	10	H
NVH Troubleshooting Chart	4	STABILIZER BAR	11	
FRONT SUSPENSION ASSEMBLY	5	Removal and Installation	11	
Components	5	TRANSVERSE LINK AND LOWER BALL JOINT ...	13	
On-Vehicle Service	6	Removal and Installation	13	I
Front Wheel Alignment	6	Inspection	13	
PRELIMINARY INSPECTION	7	TRANSVERSE LINK	13	
CAMBER, CASTER AND KINGPIN INCLINA-		LOWER BALL JOINT	14	J
TION	7	SERVICE DATA AND SPECIFICATIONS (SDS)	15	
TOE-IN	7	General Specifications (Front)	15	
FRONT WHEEL TURNING ANGLE	8	Front Wheel Alignment (Unladen*1)	15	K
COIL SPRING AND SHOCK ABSORBER	9	Lower Ball Joint	15	
Removal and Installation	9	Wheelarch Height (Unladen*)	16	

L
M

PRECAUTIONS

PRECAUTIONS

PFP:00001

Precautions

EES0001B

- When installing rubber parts, final tightening must be carried out under unladen condition* with tires on ground. Oil will shorten the life of rubber bushings. Be sure to wipe off any spilled oil.
*: Fuel, radiator coolant and engine oil full. Spare tire, jack, hand tools and mats in designated positions.
- After installing removed suspension parts, check wheel alignment and adjust if necessary.
- Use flare nut wrench when removing or installing brake tubes.
- Always torque brake lines when installing.
- Lock nuts are un reusable parts; always use new ones. When replacing, do not wipe the oil off the new lock nut before tightening.

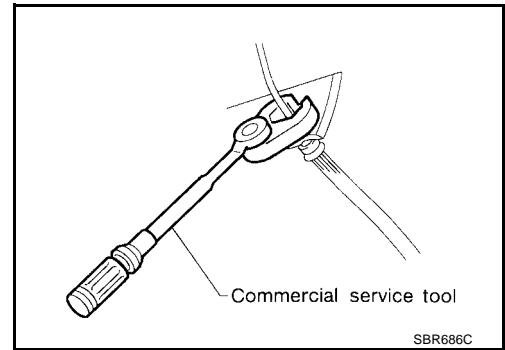

PREPARATION

PREPARATION

PF0:00002

Special Service Tools

EES0001C

The actual shapes of Kent-Moore tools may differ from those of special service tools illustrated here.

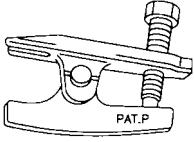
Tool number (Kent-Moore No.) Tool name	Description
HT72520000 (J25730-B) Ball joint remover  NT146	Removing tie-rod outer end and lower ball joint

Commercial Service Tools

EES0001D

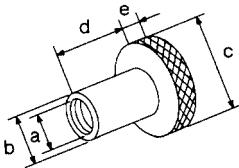
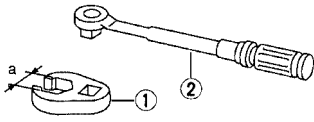
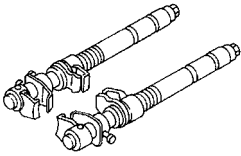
Tool name	Description
Attachment wheel alignment  NT148	Measure wheel alignment a: Screw M24 x 1.5 pitch b: 35 mm (1.38 in) dia. c: 65 mm (2.56 in) dia. d: 56 mm (2.20 in) e: 12 mm (0.47 in)
Equivalent to GG94310000 1 Flare nut crowfoot 2 Torque wrench  S-NT360	Removing and installing brake piping a: 10 mm (0.39 in)
Spring compressor  NT717	Removing and installing coil spring

A
B
C
D
FSU
F
G
H
I
J
K
L
M

NOISE, VIBRATION, AND HARSHNESS (NVH) TROUBLESHOOTING

NOISE, VIBRATION, AND HARSHNESS (NVH) TROUBLESHOOTING

PFP:00003

NVH Troubleshooting Chart

EES0001E

Use the following chart to help you find the cause of the symptom. If necessary, repair or replace these parts.

Reference page		FSU-5	FSU-5	FSU-5	—	FSU-16	FSU-5, FSU-6	FSU-6	FSU-11	FAX-4, "NVH Troubleshooting Chart"	FAX-4, "NVH Troubleshooting Chart"	WT-2, "NVH Troubleshooting Chart"	WT-2, "NVH Troubleshooting Chart"	BR-5, "NVH Troubleshooting Chart"	PS-6, "NVH Troubleshooting Chart"
Possible Cause and SUSPECTED PARTS		Improper installation, looseness	Shock absorber deformation, damage or deflection	Bushing or mounting deterioration	Parts interference	Spring fatigue	Suspension looseness	Incorrect wheel alignment	Stabilizer bar fatigue	DRIVE SHAFT	AXLE	TIRES	ROAD WHEEL	BRAKES	STEERING
Symptom	Noise	x	x	x	x	x	x			x	x	x	x	x	x
	Shake	x	x	x	x		x			x	x	x	x	x	x
	Vibration	x	x	x	x	x				x	x	x			x
	Shimmy	x	x	x	x			x			x	x	x	x	x
	Judder	x	x	x							x	x	x	x	x
	Poor quality ride or handling	x	x	x	x	x		x	x		x	x	x		

x: Applicable

FRONT SUSPENSION ASSEMBLY

FRONT SUSPENSION ASSEMBLY

PFP:54010

Components

EES000IF

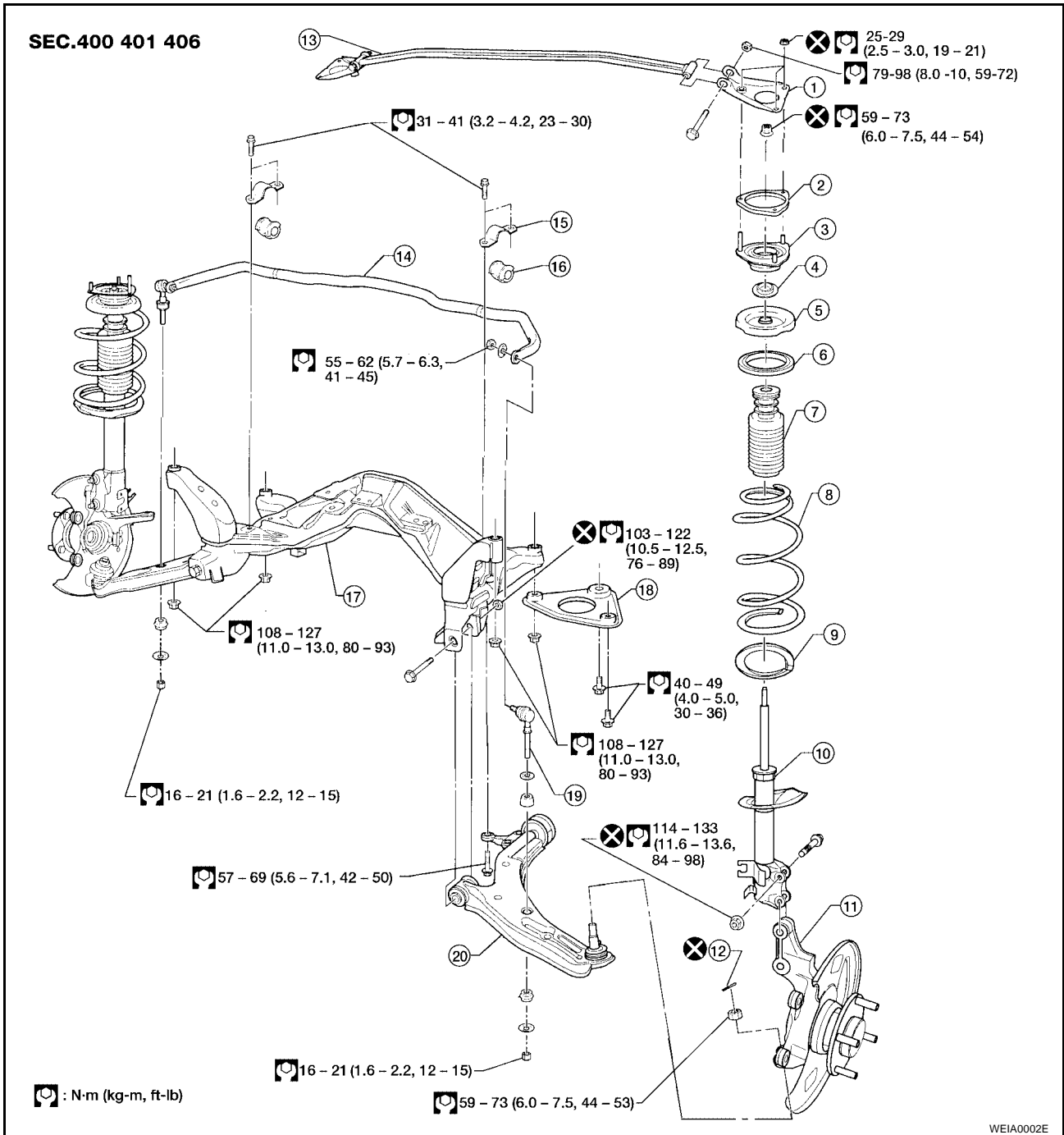

- | | | |
|------------------------------------------|------------------------------------|-----------------------------|
| 1. Strut tower bar bracket (if equipped) | 2. Strut spacer | 3. Strut mount bracket |
| 4. Strut mount bearing | 5. Spring upper seat | 6. Upper spring rubber seat |
| 7. Bound bumper rubber | 8. Coil spring | 9. Lower spring rubber seat |
| 10. Shock absorber | 11. Wheel hub and steering knuckle | 12. Cotter pin |
| 13. Strut tower bar (if equipped) | 14. Stabilizer | 15. Stabilizer clamp |
| 16. Bushing | 17. Suspension member | 18. Rebound stopper |
| 19. Connecting rod | 20. Transverse link | |

FRONT SUSPENSION ASSEMBLY

EES0001G

On-Vehicle Service

Check front axle and front suspension parts for excessive play, cracks, wear or other damage.

- Shake each front wheel to check for excessive play.
- Make sure that cotter pin is inserted.
- Retighten all axle and suspension nuts and bolts to the specified torque. Refer to [FSU-5, "Components"](#).

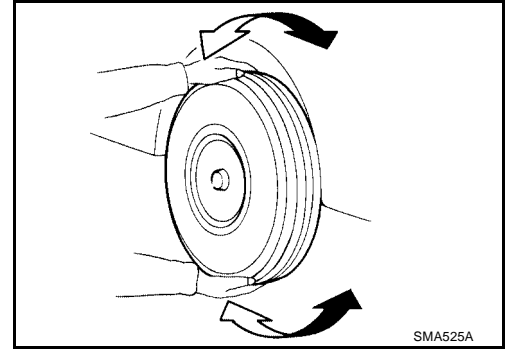

- Check strut (shock absorber) for oil leakage or other damage.
- Check suspension ball joint for grease leakage and ball joint dust cover for cracks or other damage. If ball joint dust cover is cracked or damaged, replace transverse link.

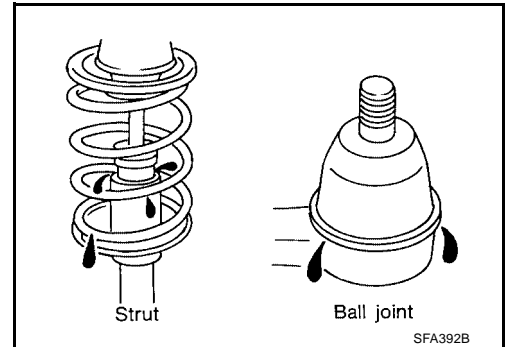

- Check spring height from top of wheelarch to the ground.
 - Vehicle must be unladen*, parked on a level surface, and tires checked for proper inflation and wear (tread wear indicator must not be showing).
 - *: Fuel, radiator coolant and engine oil full. Spare tire, jack, hand tools and mats in designated positions.
 - Bounce vehicle up and down several times before measuring.

Standard height : Refer to [FSU-16, "Wheelarch Height \(Unladen*\)"](#).

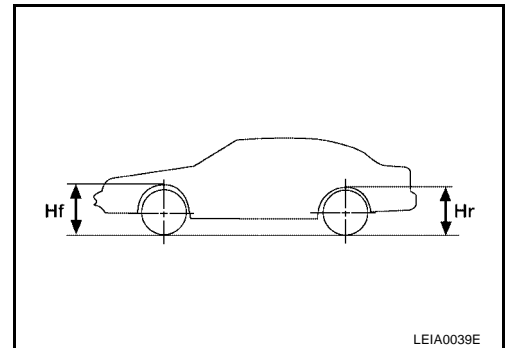

- Spring height is not adjustable. If out of specification, check for worn springs or suspension parts.

- Check suspension ball joint end play.
 - Jack up front of vehicle and set the stands.
 - Clamp dial indicator onto transverse link and place indicator tip on lower edge of brake caliper.
 - Make sure front wheels are straight and brake pedal is depressed.
 - Place a pry bar between transverse link and inner rim of road wheel.
 - While raising and releasing pry bar, observe maximum dial indicator value.

Vertical end play : 0 mm (0 in)

- If ball joint movement is beyond specifications, remove and replace it.

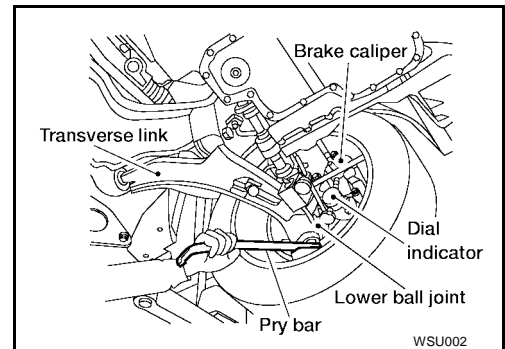

Front Wheel Alignment

EES0001H

Before checking front wheel alignment, be sure to make a preliminary inspection (unladen*).

*: Fuel, radiator coolant and engine oil full. Spare tire, jack, hand tools and mats in designated positions.

FRONT SUSPENSION ASSEMBLY

PRELIMINARY INSPECTION

1. Check tires for wear and improper inflation.
2. Check wheels for deformation, cracks and other damage. If deformed, remove wheel and check wheel runout.
- a. Remove tire from wheel and mount wheel on a tire balance machine.
- b. Set dial indicator as shown in the illustration.

Wheel runout (Dial indicator value) : Refer to [WT-3, "ROAD WHEEL"](#) .

3. Check front wheel bearings for looseness.
4. Check front suspension for looseness.
5. Check steering linkage for looseness.
6. Check that front shock absorbers work properly.
7. Check vehicle wheelarch height (unladen*). Refer to [FSU-16, "Wheelarch Height \(Unladen*\)"](#) .
 - *: Fuel, radiator coolant and engine oil full. Spare tire, jack, hand tools and mats in designated positions.

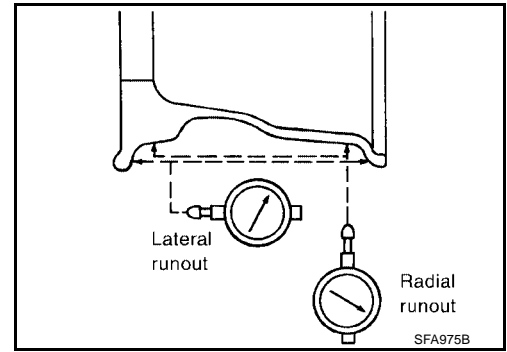

CAMBER, CASTER AND KINGPIN INCLINATION

Camber, caster and kingpin inclination are preset at factory and cannot be adjusted.

1. Measure camber, caster and kingpin inclination of both right and left wheels with a suitable alignment gauge.

Camber, caster and kingpin inclination : Refer to [FSU-15, "Front Wheel Alignment \(Unladen*1\)"](#) .

2. If camber, caster or kingpin inclination is not within specification, inspect front suspension parts. Replace damaged or worn out parts.

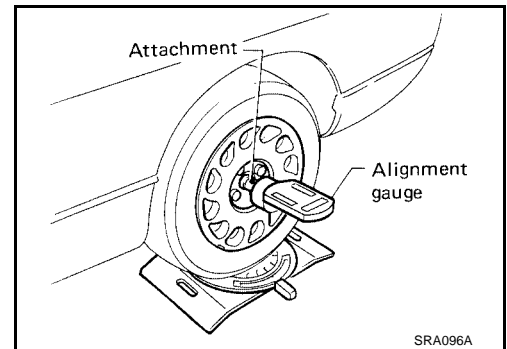

TOE-IN

Measure toe-in using the following procedure.

WARNING:

- Always perform the following procedure on a flat surface.
- Make sure that no person is in front of the vehicle before pushing it.

1. Bounce front of vehicle up and down to stabilize the posture.
2. Push the vehicle straight ahead about 5 m (16 ft).
3. Put a mark on base line of tread (rear side) of both tires at the same height as hub center. These are measuring points.

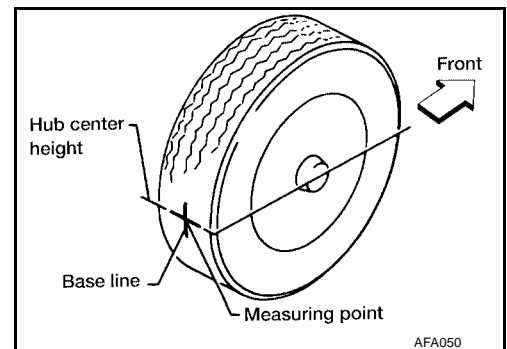

4. Measure distance "A" (rear side).
5. Push the vehicle slowly ahead to rotate the wheels 180 degrees (1/2 turn).

If the wheels have rotated more than 180 degrees (1/2 turn), try the above procedure again from the beginning. Never push vehicle backward.

6. Measure distance "B" (front side).

Total toe-in : Refer to [FSU-15, "Front Wheel Alignment \(Unladen*1\)"](#) .

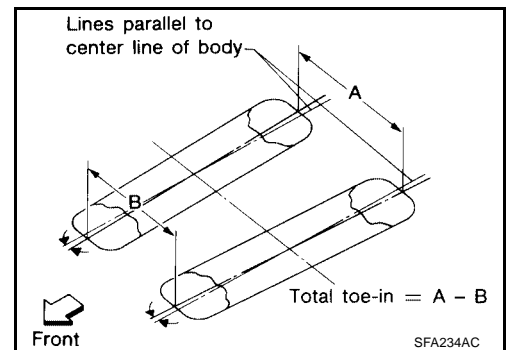

FRONT SUSPENSION ASSEMBLY

7. Adjust toe-in by varying the length of steering tie-rods.
 - a. Loosen lock nuts.
 - b. Adjust toe-in by screwing tie-rods in and out.

Standard length "L" : Refer to [FSU-15, "Front Wheel Alignment \(Unladen*1\)"](#)

- c. Tighten lock nuts to specified torque. Refer to [FSU-5, "Components"](#).

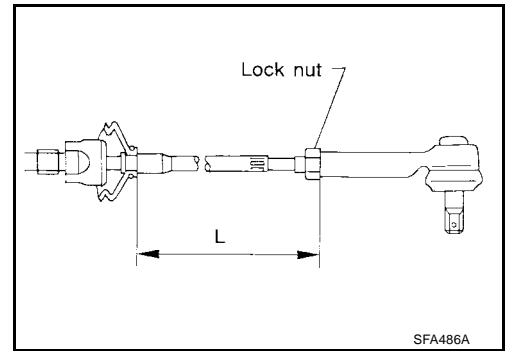

FRONT WHEEL TURNING ANGLE

1. Set wheels in straight-ahead position. Then move vehicle forward until front wheels rest on turning radius gauge properly.
2. Rotate steering wheel all the way right and left; measure turning angle.

Do not hold the steering wheel on full lock for more than 15 seconds.

Wheel turning angle (Full turn) : Refer to [FSU-15, "Front Wheel Alignment \(Unladen*1\)"](#).

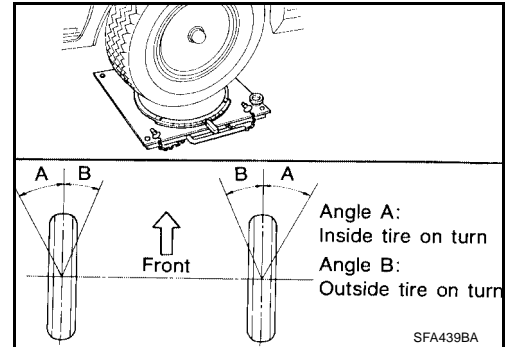

COIL SPRING AND SHOCK ABSORBER

PFP:56210

COIL SPRING AND SHOCK ABSORBER

Removal and Installation

EES000II

- Remove shock absorber fixing bolt and nut (to hoodledge).
- Do not remove piston rod lock nut on vehicle.

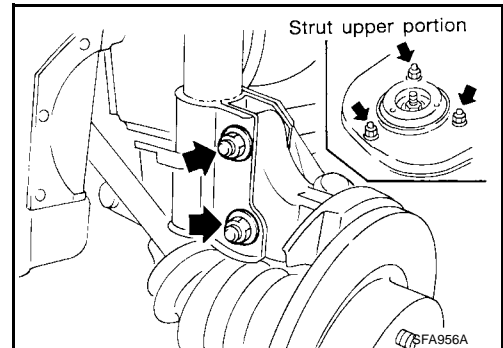

- When installing strut spacer, it must be positioned as shown.

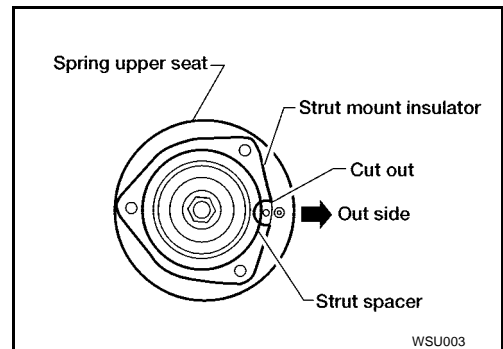

Disassembly

EES000I

1. Set shock absorber on vise, then **loosen** piston rod lock nut.
 - Do not remove piston rod lock nut at this time.
2. Compress spring with Tool so that shock absorber mounting insulator can be turned by hand.

WARNING:

Make sure that the pawls of the two spring compressors are firmly hooked on the spring. The spring compressors must be tightened alternately so as not to tilt the spring.

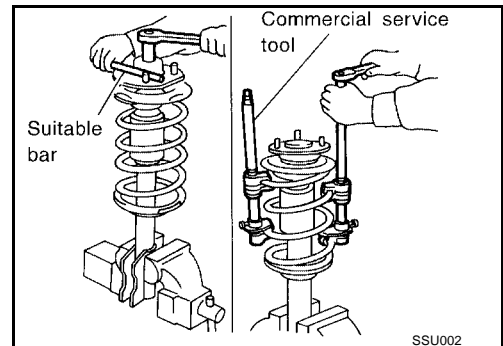

3. Remove piston rod lock nut.

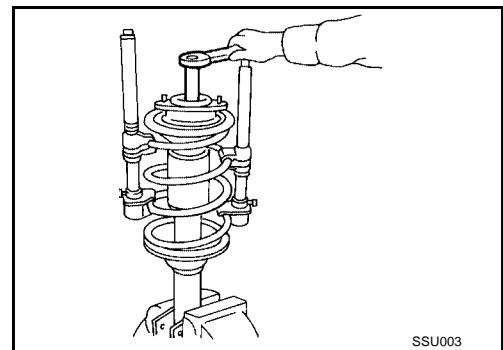

Inspection

SHOCK ABSORBER ASSEMBLY

EES000IK

- Check for smooth operation through a full stroke, both compression and extension.
- Check for oil leakage on welded or gland packing portions.
- Check piston rod for cracks, deformation or other damage and replace if necessary.

A
B
C
D
FSU
F
G
H
I
J
K
L
M

COIL SPRING AND SHOCK ABSORBER

MOUNTING INSULATOR AND RUBBER PARTS

- Check cemented rubber-to-metal portion for separation or cracks. Check rubber parts for deterioration and replace if necessary.

THRUST BEARING

- Check thrust bearing parts for abnormal noise or excessive rattle in axial direction and replace if necessary.

COIL SPRING

- Check for cracks, deformation or other damage and replace if necessary.

Assembly

- When installing coil spring on strut, it must be positioned as shown.

EES0001L

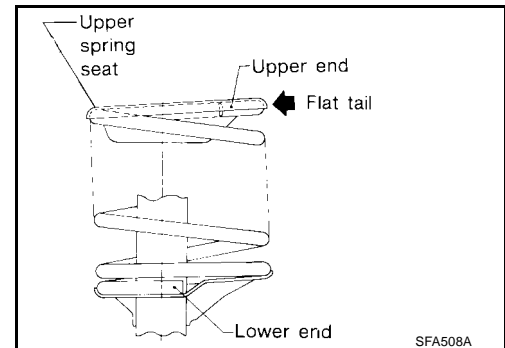

- Install upper spring seat with alignment mark facing the outer side of vehicle, in line with strut-to-knuckle attachment points.
- **Replace strut lower mounting nuts.**
- **When installing strut to knuckle, be sure to hold bolts and tighten nuts.**

**Strut to knuckle
tightening torque : 114 - 133 N·m
(11.6 - 13.6 kg-m, 84 - 98 ft-lb)**

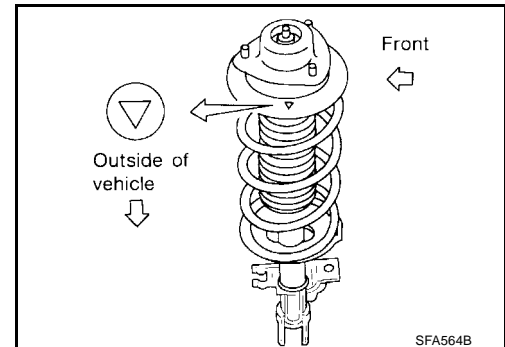

STABILIZER BAR

STABILIZER BAR

PFP:54611

EES000IM

Removal and Installation

- Remove four stabilizer bar mounting nuts from each side.

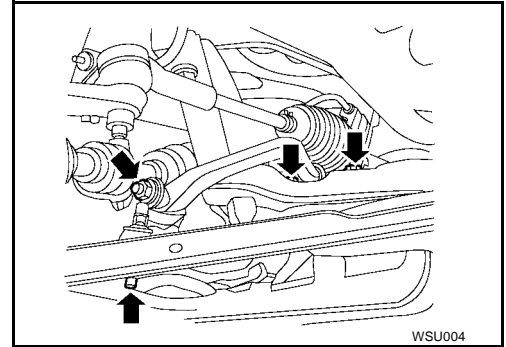

- When installing stabilizer, make sure the paint mark and clamp face in their correct directions.

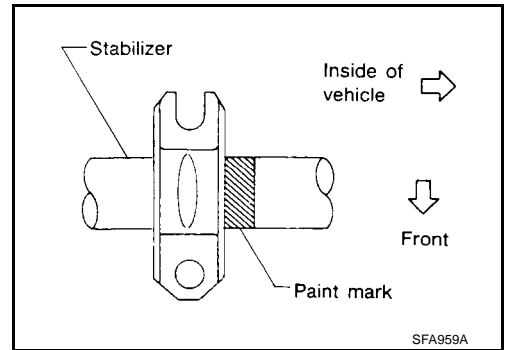

- Make sure that the slit in the bushing is in the position shown.

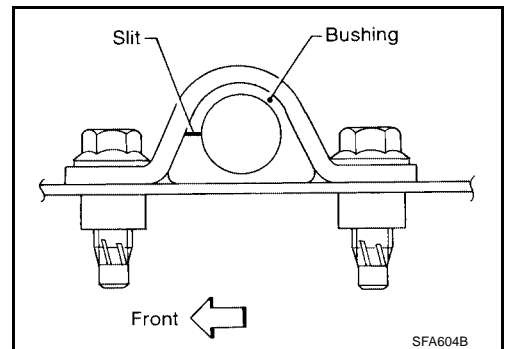

- Install four stabilizer bar mounting nuts at each side.

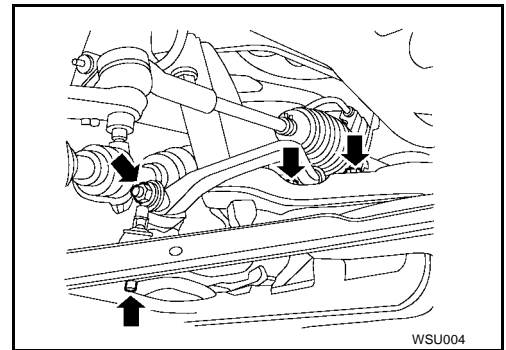

A
B
C
D
FSU
F
G
H
I
J
K
L
M

STABILIZER BAR

- Install stabilizer bar with ball joint socket properly placed.

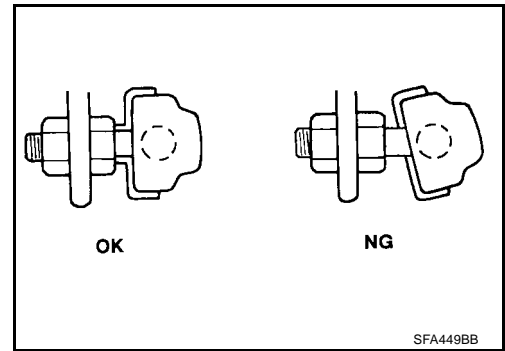

- Check stabilizer for deformation or cracks and replace if necessary.
- Check rubber bushings for deterioration or cracks and replace if necessary.
- Check ball joint can rotate in all directions. If movement is not smooth and free, replace stabilizer bar connecting rod.

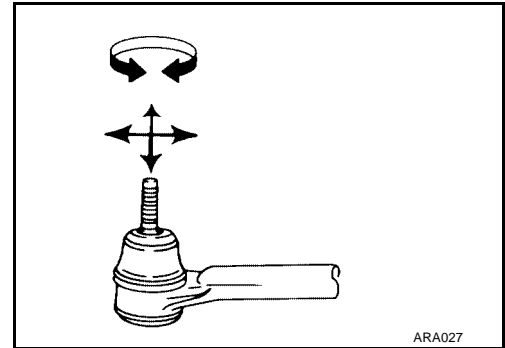

TRANSVERSE LINK AND LOWER BALL JOINT

PFP:54500

TRANSVERSE LINK AND LOWER BALL JOINT

EES000IN

Removal and Installation

1. Remove wheel bearing lock nut.
2. Remove tie-rod ball joint.
3. Remove strut lower bracket fixing bolts and nuts.
4. Separate drive shaft from knuckle by slightly tapping drive shaft end.

Cover boots with shop towel so as not to damage them when removing drive shaft.

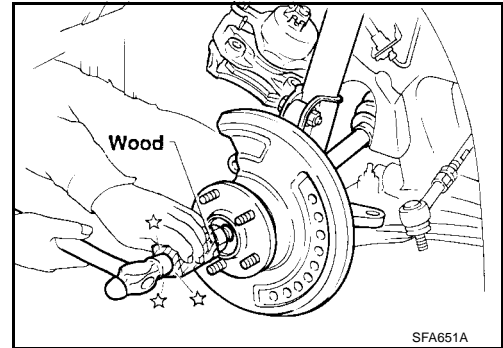

5. Separate lower ball joint stud from knuckle with suitable tool.

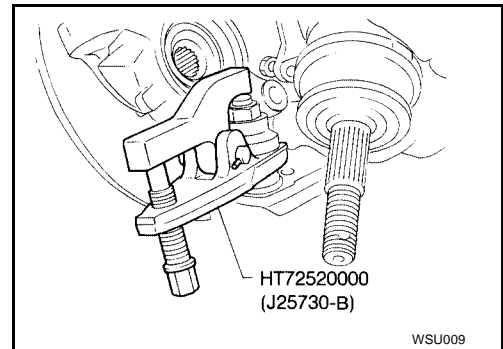

6. Remove fixing bolts.
7. Remove transverse link and lower ball joint.
8. During installation, final tightening must be carried out at curb weight with tires on the ground. Refer to [FSU-5, "Components"](#).
9. After installation, check wheel alignment. Refer to [FSU-6, "Front Wheel Alignment"](#).

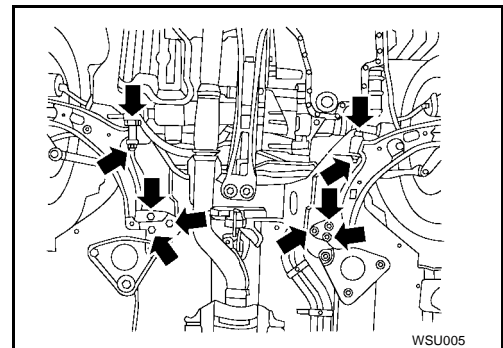

Inspection TRANSVERSE LINK

EES000IO

- Check transverse link for damage, cracks or deformation and replace if necessary.
- Check rubber bushing for damage, cracks and deformation and replace if necessary.

A
B
C
D
FSU
F
G
H
I
J
K
L
M

TRANSVERSE LINK AND LOWER BALL JOINT

LOWER BALL JOINT

- Check ball joint for play. Replace transverse link assembly if any of the following cases occur: Ball stud is worn, play in axial direction is excessive or joint is hard to swing. Before checking, turn ball joint at least 10 revolutions so that ball joint is properly broken in.

Swinging force "A" : 7.8 - 77.5 N (0.8 - 7.9 kg,
1.8 - 17.4 lb)
(measuring point
cotter pin hole of
ball stud)

Turning torque "B" : 0.50 - 4.90 N·m
(5.1 - 50 kg-cm,
4.4 - 43.4 in-lb)

Vertical end play "C" : 0 mm (0 in)

- Check dust cover for damage. Replace it and cover clamp if necessary.

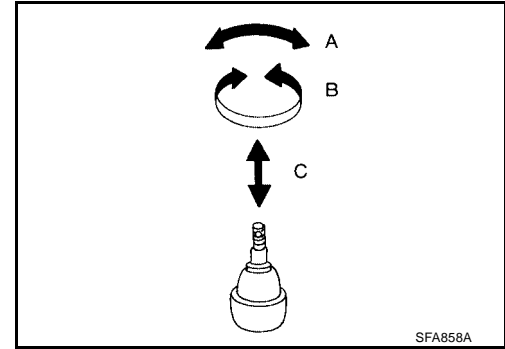

SERVICE DATA AND SPECIFICATIONS (SDS)

SERVICE DATA AND SPECIFICATIONS (SDS)

PF0:00030

General Specifications (Front)

EES0001P

Suspension type	Independent MacPherson strut
Shock absorber type	Double-acting hydraulic
Stabilizer bar	Standard equipment

Front Wheel Alignment (Unladen*1)

EES0001Q

Engine		QG18DE	QR25DE	
Camber Degree minute (Decimal degree)	Minimum	-1°05' (-1.08°)	-1°12' (-1.2°)	
	Nominal	-0°20' (-0.33°)	-0°27' (-0.45°)	
	Maximum	0°25' (0.42°)	0°18' (0.3°)	
	Left and right difference	45' (0.75°) or less	45' (0.75°) or less	
Caster Degree minute (Decimal degree)	Minimum	0°50' (0.83°)	0°58' (0.97°)	
	Nominal	1°35' (1.58°)	1°43' (1.72°)	
	Maximum	2°20' (2.33°)	2°28' (2.47°)	
	Left and right difference	45' (0.75°) or less	45' (0.75°) or less	
Kingpin inclination Degree minute (Decimal degree)	Minimum	13°52' (13.87°)	14°03' (14.05°)	
	Nominal	14°37' (14.62°)	14°46' (14.77°)	
	Maximum	15°22' (15.37°)	15°31' (15.52°)	
Total toe-in	Distance (A - B) mm (in)	Minimum	1 (0.039")	1 (0.039")
		Nominal	2 (0.079")	2 (0.079")
		Maximum	3 (0.118")	3 (0.118")
	Angle (left plus right) Degree minute (Decimal degree)	Minimum	5.5' (0.08°)	5.5' (0.08°)
		Nominal	11' (0.18°)	11' (0.18°)
		Maximum	16' (0.27°)	16' (0.27°)
Wheel turning angle Full turn*2	Inside Degree minute (Decimal degree)	Minimum	34° (34.0°)	29° (29.0°)
		Nominal	37° (37.0°)	32° (32.0°)
		Maximum	38° (38.0°)	33° (33.0°)
	Outside Degree minute (Decimal degree)	Nominal	31° (31.0°)	27° (27.0°)

*1: Fuel, radiator coolant and engine oil full. Spare tire, jack, hand tools and mats in designated positions.

*2: On power steering models, wheel turning force (at circumference of steering wheel) of 98 to 147 N (10 to 15 kg, 22 to 33 lb) with engine idle.

Lower Ball Joint

EES0001R

Swinging force "A" (Measuring point: cotter pin hole of ball stud) N (kg, lb)	7.8 - 77.5 (0.8 - 7.9, 1.8 - 17.4)
Turning torque "B" N-m (kg-cm, in-lb)	0.50 - 4.90 (5.1 - 50.0, 4.4 - 43.4)
Vertical end play "C" mm (in)	0 (0)

SERVICE DATA AND SPECIFICATIONS (SDS)

Wheelarch Height (Unladen*)

EES0012V

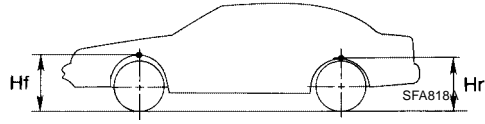

Engine Model	QG18DE	QR25DE	
		SE-R	SPEC-V
Tire Size	195/60HR15	195/55HR16	215/45ZR17
Front (Hf) mm (in)	664 (26.14)	660 (25.98)	664 (26.14)
Rear (Hr) mm (in)	658 (25.91)	652 (25.67)	655 (25.79)

*: Fuel, radiator coolant and engine oil full. Spare tire, jack, hand tools and mats in designated positions.