

A
B
MT
D
E
F
G
H
I
J
K
L
M

SECTION **MT**

MANUAL TRANSAXLE

CONTENTS

RS5F70A	
PRECAUTIONS	4
Caution	4
PREPARATION	5
Special Service Tools	5
Commercial Service Tools	7
NOISE, VIBRATION, AND HARSHNESS (NVH)	
TROUBLESHOOTING	9
NVH Troubleshooting Chart	9
DESCRIPTION	10
Cross-sectional View	10
DOUBLE-CONE SYNCHRONIZER	10
M/T OIL	11
Replacement	11
DRAINING	11
FILLING	11
Checking	11
OIL LEAKAGE AND OIL LEVEL	11
SIDE OIL SEAL	12
Removal and Installation	12
POSITION SWITCH	13
Position Switch Check	13
BACK-UP LAMP SWITCH	13
PNP SWITCH	13
CONTROL LINKAGE	14
Removal and Installation	14
TRANSAXLE GEAR CONTROL	14
STRIKING ROD OIL SEAL	15
TRANSAXLE ASSEMBLY	16
Removal and Installation	16
REMOVAL	16
INSTALLATION	19
Component Parts	20
CASE COMPONENTS	20
GEAR COMPONENTS	21
SHIFT CONTROL COMPONENTS	22
FINAL DRIVE COMPONENTS	23
Disassembly and Assembly	23
DISASSEMBLY	23
ASSEMBLY	30
INPUT SHAFT AND GEARS	41
Disassembly	41
Inspection	42
GEAR AND SHAFT	42
SYNCHRONIZERS	43
BEARING	44
Assembly	44
MAINSHAFT AND GEARS	48
Disassembly	48
Inspection	50
GEAR AND SHAFT	50
SYNCHRONIZERS	50
BEARING	51
Assembly	52
FINAL DRIVE	58
Pre-inspection	58
DIFFERENTIAL CASE SIDE	58
Disassembly	58
Inspection	59
GEAR, WASHER, SHAFT AND CASE	59
BEARING	59
Assembly	59
SHIFT CONTROL	62
Inspection	62
SERVICE DATA AND SPECIFICATIONS (SDS)	63
General Specifications	63
TRANSAXLE	63
FINAL GEAR	63
Gear End Play	64
Clearance Between Baulk Ring and Gear	64
3RD, 4TH, 5TH, REVERSE BAULK RING	64
1ST AND 2ND BAULK RING	64
Available Snap Rings	64
SNAP RING	64
Available C-rings	64
4TH INPUT GEAR C-RING	64
5TH INPUT GEAR REAR C-RING	65
MAINSHAFT C-RING	65
Available Adjusting Shims	65
INPUT SHAFT REAR BEARING ADJUSTING	

SHIM	65	DISASSEMBLY	88
MAINSHAFT ADJUSTING SHIM	66	ASSEMBLY	92
MAINSHAFT REAR BEARING ADJUSTING SHIM	66	Adjustment	98
Available Thrust Washer	67	INPUTSHAFT END PLAY	98
MAINSHAFT THRUST WASHER	67	DIFFERENTIAL SIDE BEARING PRELOAD	99
Available Washers	67	MAINSHAFT END PLAY	100
DIFFERENTIALSIDEGEARTHURSTWASHER	67	REVERSE IDLER GEAR END PLAY	101
Available Shims — Differential Side Bearing Preload and Adjusting Shim	68	INPUT SHAFT AND GEARS	103
BEARING PRELOAD	68	Disassembly and Assembly	103
DIFFERENTIAL SIDE BEARING ADJUSTING SHIMS	68	DISASSEMBLY	103
		INSPECTION AFTER DISASSEMBLY	104
		ASSEMBLY	105
		MAINSHAFT AND GEARS	110
		Disassembly and Assembly	110
		DISASSEMBLY	110
		INSPECTION AFTER DISASSEMBLY	111
		ASSEMBLY	113
		REVERSE IDLER SHAFT AND GEARS	118
		Disassembly and Assembly	118
		DISASSEMBLY	118
		INSPECTION AFTER DISASSEMBLY	118
		ASSEMBLY	119
		FINAL DRIVE	120
		Disassembly and Assembly	120
		PRE-INSPECTION	120
		DISASSEMBLY	120
		INSPECTION AFTER DISASSEMBLY	121
		ASSEMBLY	121
		SHIFT CONTROL	124
		Inspection	124
		SHIFT FORK	124
		SERVICE DATA AND SPECIFICATIONS (SDS) ...	125
		General Specifications	125
		TRANSAXLE	125
		FINAL GEAR	125
		Gear End Play	126
		Clearance Between Baulk Ring and Gear	126
		3RD, 4TH, 5TH & REVERSE BAULK RING	126
		1ST AND 2ND DOUBLE BAULK RING	126
		Available Snap Rings	126
		INPUT SHAFT SPACER	126
		5TH MAIN GEAR	126
		Available C-rings	127
		MAINSHAFT C-RING	127
		Available Thrust Washers	127
		INPUT SHAFT THRUST WASHER	127
		DIFFERENTIALSIDEGEARTHURSTWASHER	127
		Available Adjusting Shims	128
		MAINSHAFT ADJUSTING SHIM	128
		INPUT SHAFT REAR BEARING ADJUSTING SHIM	128
		SHIM	128
		MAINSHAFT REAR BEARING ADJUSTING SHIM	128
		REVERSE IDLER GEAR ADJUSTING SHIM	129
		Available Shims	129
		BEARING PRELOAD	129
		DIFFERENTIAL SIDE BEARING ADJUSTING SHIM(S)	129

RS5F51A

PRECAUTIONS	69
Cautions	69
PREPARATION	70
Special Service Tools	70
Commercial Service Tools	72
NOISE, VIBRATION, AND HARSHNESS (NVH)	
TROUBLESHOOTING	73
NVH Troubleshooting Chart	73
DESCRIPTION	74
Cross-sectional View	74
DOUBLE-CONE SYNCHRONIZER	75
REVERSE GEAR	75
M/T OIL	76
Replacement	76
DRAINING	76
FILLING	76
Checking	76
OIL LEAKAGE AND OIL LEVEL	76
SIDE OIL SEAL	77
Removal and Installation	77
REMOVAL	77
INSTALLATION	77
POSITION SWITCH	78
Checking	78
BACK-UP LAMP SWITCH	78
PARK/NEUTRAL POSITION SWITCH	78
CONTROL LINKAGE	79
Removal and Installation of Control Device and Cable	79
Cable Adjustment	80
AIR BREATHER HOSE	81
Removal and Installation	81
TRANSAXLE ASSEMBLY	82
Removal and Installation	82
REMOVAL	82
INSTALLATION	83
Component Parts	84
CASE AND HOUSING COMPONENTS	84
GEAR COMPONENTS	85
SHIFT CONTROL COMPONENTS	87
FINAL DRIVE COMPONENTS	88
Disassembly and Assembly	88

RS6F51H

PRECAUTIONS	130	INPUT SHAFT AND GEARS	165	
Caution	130	Disassembly and Assembly	165	A
PREPARATION	131	DISASSEMBLY	165	
Special Service Tools	131	INSPECTION AFTER DISASSEMBLY	166	
Commercial Service Tools	133	ASSEMBLY	167	B
NOISE, VIBRATION, AND HARSHNESS (NVH)		MAINSHAFT AND GEARS	172	
TROUBLESHOOTING	134	Disassembly and Assembly	172	
NVH Troubleshooting Chart	134	DISASSEMBLY	172	
DESCRIPTION	135	INSPECTION AFTER DISASSEMBLY	173	
Cross-sectional View	135	ASSEMBLY	175	MT
DOUBLE-CONE SYNCHRONIZER	136	REVERSE IDLER SHAFT AND GEARS	180	
REVERSE GEAR	136	Disassembly and Assembly	180	D
M/T OIL	137	DISASSEMBLY	180	
Replacement	137	INSPECTION AFTER DISASSEMBLY	180	
DRAINING	137	ASSEMBLY	181	E
FILLING	137	FINAL DRIVE	182	
Checking	137	Disassembly and Assembly	182	
OIL LEAKAGE AND OIL LEVEL	137	DISASSEMBLY	182	
SIDE OIL SEAL	138	INSPECTION AFTER DISASSEMBLY	182	F
Removal and Installation	138	ASSEMBLY	182	
REMOVAL	138	SHIFT CONTROL	184	
INSTALLATION	138	Inspection	184	G
POSITION SWITCH	139	SHIFT FORK	184	
Checking	139	SERVICE DATA AND SPECIFICATIONS (SDS) ...	185	
BACK-UP LAMP SWITCH	139	General Specifications	185	H
PARK/NEUTRAL POSITION SWITCH	139	TRANSAXLE	185	
CONTROL LINKAGE	140	FINAL GEAR	186	
Removal and Installation of Control Device and		Gear End Play	186	I
Cable	140	Clearance Between Baulk Ring and Gear	186	
Cable Adjustment	141	3RD, 4TH, 5TH, 6TH & REVERSE BAULK RING	186	
AIR BREATHER HOSE	142	1ST AND 2ND DOUBLE BAULK RING	186	
Removal and Installation	142	Available Snap Rings	187	J
TRANSAXLE ASSEMBLY	143	6TH BUSHING	187	
Removal and Installation	143	Available C-rings	187	
REMOVAL	143	MAINSHAFT C-RING	187	K
INSTALLATION	144	Available Thrust Washers	187	
Component Parts	145	INPUT SHAFT THRUST WASHER	187	
CASE AND HOUSING COMPONENTS	145	Available Adjusting Shims	188	L
GEAR COMPONENTS	146	MAINSHAFT ADJUSTING SHIM	188	
SHIFT CONTROL COMPONENTS	148	INPUT SHAFT REAR BEARING ADJUSTING		
FINAL DRIVE COMPONENTS	149	SHIM	188	M
Disassembly and Assembly	149	MAINSHAFT REAR BEARING ADJUSTING		
DISASSEMBLY	149	SHIM	188	
ASSEMBLY	153	REVERSE IDLER GEAR ADJUSTING SHIM	189	
Adjustment	160	6TH MAIN GEAR ADJUSTING SHIM	189	
INPUTSHAFT END PLAY	160	Available Shims	189	
DIFFERENTIAL SIDE BEARING PRELOAD ...	161	BEARING PRELOAD	189	
MAINSHAFT END PLAY	162	DIFFERENTIAL SIDE BEARING ADJUSTING		
REVERSE IDLER GEAR END PLAY	163	SHIM(S)	189	

PRECAUTIONS

Caution

- Do not reuse transaxle oil, once it has been drained.
- Check oil level or replace oil with vehicle on level ground.
- During removal or installation, keep inside of transaxle clear of dust or dirt.
- Check for the correct installation status prior to removal or disassembly. If mating marks are required, be certain they do not interfere with the function of the parts they are applied to.
- In principle, tighten bolts or nuts gradually in several steps working diagonally from inside to outside. If tightening sequence is specified, use it.
- Be careful not to damage sliding surfaces and mating surfaces.

PREPARATION

[RS5F70A]



PF0:00002

ECS005TE

PREPARATION

Special Service Tools

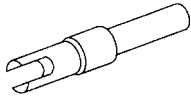
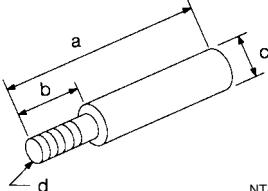
The actual shapes of the Kent-Moore tools may differ from those of the special service tools illustrated here.

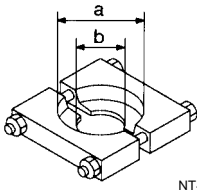
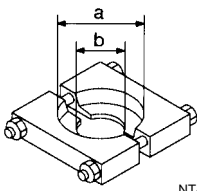
Tool number (Kent-Moore No.) Tool name	Description
KV38107700 (J39027) Preload adapter  NT087	Measuring turning torque of final drive assembly Measuring total turning torque Measuring clearance between side gear and differential case with washer Selecting differential side bearing adjusting shim [Use with KV38106000 (J34291-B).]
KV38106000 (J34291-B) Height gauge adapter (differential side bearing)  NT418	Selecting differential side bearing adjusting shim [Use with KV38107700 (J39027).] a: 140 mm (5.51 in) b: 40 mm (1.57 in) c: 16 mm (0.63 in) dia. d: M8 × 1.25P
KV32101000 (J25689-A) Pin punch  NT410	Removing and installing retaining pin Removing and installing lock pin Removing selector shaft Removing welch plug a: 4 mm (0.16 in) dia.
KV31100300 (J25689-A) Pin punch  NT410	Removing and installing retaining pin a: 4.5 mm (0.177 in) dia.
ST30031000 (J22912-O1) Puller  NT411	Removing 3rd, 5th input gear Removing 3rd & 4th and 5th & Rev synchronizer hub Removing mainshaft rear bearing Removing 2nd gear, 5th gear bush Removing 1st & 2nd synchronizer hub, 1st and 4th main gear Removing and installing differential side bearing a: 90 mm (3.54 in) dia. b: 50 mm (1.97 in) dia.
ST30021000 (J22912-O1) Puller  NT411	Removing input shaft front and rear bearing Installing input shaft front and rear bearing Installing 5th input gear, 3rd main gear and 4th main gear Installing 1st & 2nd, 3rd & 4th and 5th & Rev synchronizer hub Installing 2nd gear bush, 5th gear bush, Rev gear bush Installing mainshaft rear bearing a: 110 mm (4.33 in) dia. b: 68 mm (2.68 in) dia.

A

B

MT

D

E

F

G

H

I

J

K

L

M

PREPARATION

[RS5F70A]

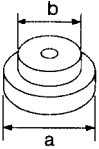
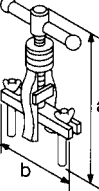
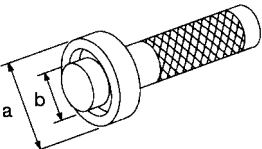
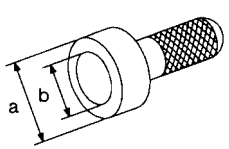
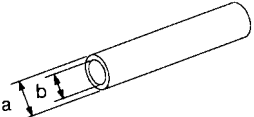
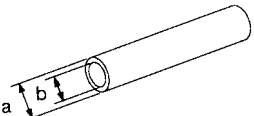
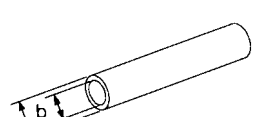
Tool number (Kent-Moore No.) Tool name	Description
ST33061000 (J8107-2) Drift <div style="text-align: center;">  <p>NT073</p> </div>	Removing differential side bearing a: 39 mm (1.54 in) dia. b: 29.5 mm (1.16 in) dia.
ST33290001 (J34286) Puller <div style="text-align: center;">  <p>NT414</p> </div>	<ul style="list-style-type: none"> ● Removing idler gear bearing outer race a: 250 mm (9.84 in) b: 160 mm (6.30 in)
ST33230000 (J25805-O1) Drift <div style="text-align: center;">  <p>NT084</p> </div>	Removing differential oil seal Installing differential side bearing a: 51 mm (2.01 in) dia. b: 28.5 mm (1.122 in) dia.
ST30720000 (J25405) Drift <div style="text-align: center;">  <p>NT115</p> </div>	Installing differential side bearing outer race a: 77 mm (3.03 in) dia. b: 55.5 mm (2.185 in) dia.
ST22350000 (J25678-O1) Drift <div style="text-align: center;">  <p>NT065</p> </div>	Installing input shaft front and rear bearing a: 34 mm (1.34 in) dia. b: 28 mm (1.10 in) dia.
ST22452000 (J34335) Drift <div style="text-align: center;">  <p>NT065</p> </div>	Installing 3rd and 4th main gear Installing 5th gear bush Installing 5th & Rev synchronizer hub Installing Rev gear bush Installing mainshaft rear bearing a: 45 mm (1.77 in) dia. b: 36 mm (1.42 in) dia.
ST37750000 (J34335) Drift <div style="text-align: center;">  <p>NT065</p> </div>	Installing input shaft oil seal Installing 5th synchronizer Installing mainshaft rear bearing Installing 5th main gear Installing 3rd & 4th synchronizer hub Installing striking rod oil seal Installing clutch housing dust seal a: 40 mm (1.57 in) dia. b: 31 mm (1.22 in) dia.

PREPARATION

[RS5F70A]

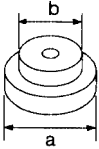
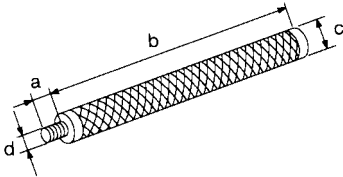
Tool number (Kent-Moore No.) Tool name	Description
ST30621000 (J35869) Drift  NT073	Installing differential side bearing outer race [Use with ST30611000 (J25742-1).] a: 79 mm (3.11 in) dia. b: 59 mm (2.32 in) dia.
ST30611000 (J25742-1) Drift handle  NT419	Installing differential side bearing outer race [Use with ST30621000 (J35869).] a: 15 mm (0.59 in) b: 335 mm (13.19 in) c: 25 mm (0.98 in) dia. d: M12 × 1.5P

Commercial Service Tools

ECS005TF

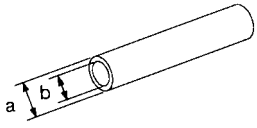
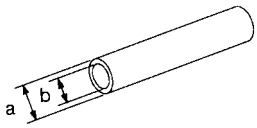
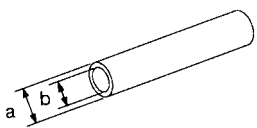
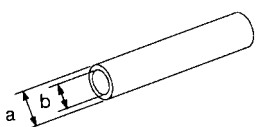
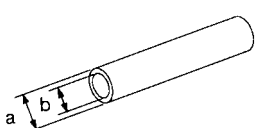
Tool name	Description
Drift  NT065	Installing differential side bearing inner race a: 56 mm (2.20 in) dia. b: 50.5 mm (1.988 in) dia.
Drift  NT065	Removing input shaft rear bearing Removing mainshaft rear bearing a: 22 mm (0.87 in) dia. b: 16 mm (0.63 in) dia.
Drift  NT065	Installing differential oil seal (Transaxle case side) a: 58 mm (2.28 in) dia. b: 50 mm (1.97 in) dia.
Drift  NT065	Installing differential oil seal (Clutch housing side) a: 54 mm (2.13 in) dia. b: 50 mm (1.97 in) dia.
Drift  NT065	Installing 2nd gear bush a: 38 mm (1.50 in) dia. b: 33 mm (1.30 in) dia.

PREPARATION

[RS5F70A]

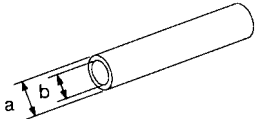
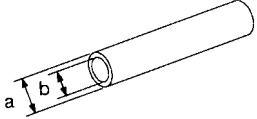
Tool name	Description
<p data-bbox="159 197 207 218">Drift</p>  <p data-bbox="850 396 894 413">NT065</p>	<p data-bbox="1013 197 1468 247">Installing 3rd & 4th and 1st & 2nd synchronizer hub</p> <p data-bbox="1013 254 1338 279">Installing mainshaft front bearing</p> <p data-bbox="1013 285 1247 310">a: 50 mm (1.97 in) dia.</p> <p data-bbox="1013 317 1247 342">b: 41 mm (1.61 in) dia.</p>
<p data-bbox="159 434 207 455">Drift</p>  <p data-bbox="850 634 894 651">NT065</p>	<p data-bbox="1013 434 1289 459">Installing input shaft oil seal</p> <p data-bbox="1013 466 1247 491">Installing 5th input gear</p> <p data-bbox="1013 497 1247 522">a: 39 mm (1.54 in) dia.</p> <p data-bbox="1013 529 1247 554">b: 30 mm (1.18 in) dia.</p>

NOISE, VIBRATION, AND HARSHNESS (NVH) TROUBLESHOOTING

[RS5F70A]

NOISE, VIBRATION, AND HARSHNESS (NVH) TROUBLESHOOTING

PFP:00003

NVH Troubleshooting Chart

ECS005TG

Use the chart below to help you find the cause of the symptom. The numbers indicate the order of the inspection. If necessary, repair or replace these parts.

Reference page		MT-11	MT-11	MT-11	MT-20			MT-14	MT-22		MT-21, MT-23			
Suspected Parts (possible cause)		(Oil level is low)	(Wrong oil)	(Oil level is high)	Gasket (damaged)	Oil Seal (worn or damaged)	O-Ring (worn or damaged)	Control Rod (worn)	Check Plug Return Spring and Check Ball (worn or damaged)	Shift Fork (worn)	Gear (worn or damaged)	Bearing (worn or damaged)	Baulk Ring (worn or damaged)	Insert Spring, Shifting Insert (damaged)
Symptom	Noise	1	2								3	3		
	Oil leakage		3	1	2	2	2							
	Hard to shift or will not shift		1	1				2					3	3
	Jumps out of gear							1	2	3	3			

A
B
MT
D
E
F
G
H
I
J
K
L
M

DESCRIPTION

Cross-sectional View

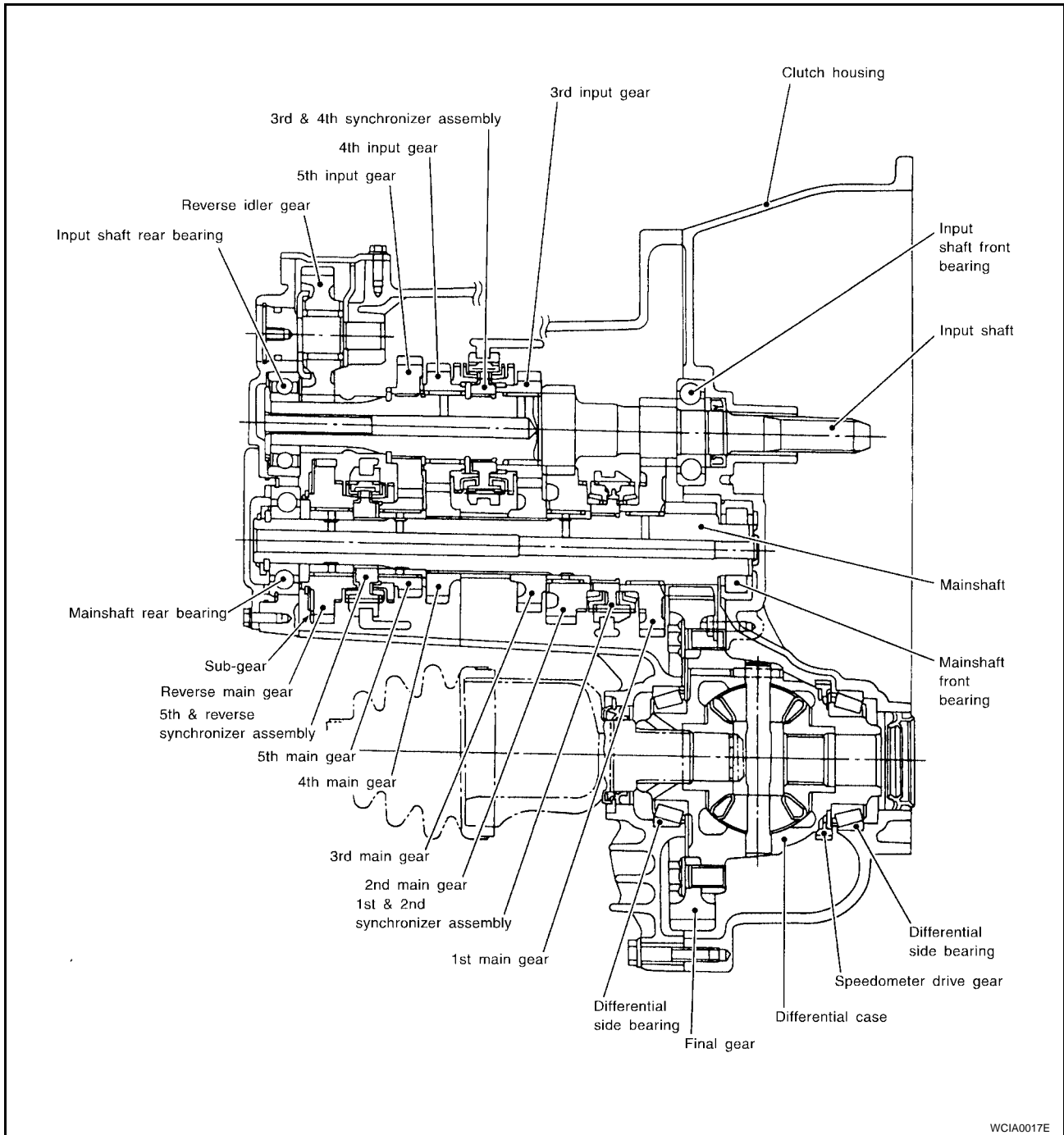

DOUBLE-CONE SYNCHRONIZER

Double-cone synchronizer is used for 1st and 2nd gears to reduce operating force of the shift lever.

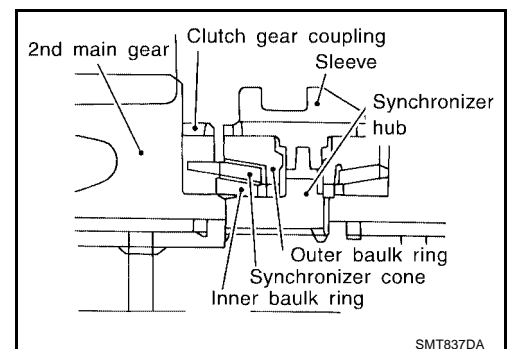

M/T OIL

Replacement
DRAINING

1. Start the engine and let it run to warm up the transaxle.
2. Stop the engine. Remove drain plug and drain oil.
3. Set a gasket on the drain plug and install it on the transaxle.

Drain plug : 10 - 19 N·m (1.0 - 2.0 kg·m, 87 - 173 in·lb)

CAUTION:

Do not reuse gasket.

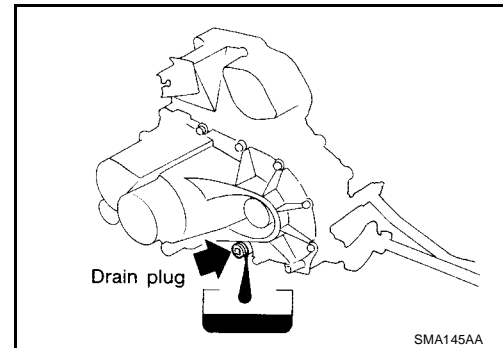

FILLING

1. Remove filler plug. Fill with new oil until oil level reaches the specified limit near filler plug mounting hole.

Oil grade : API GL-4

Capacity (reference) : Approximately 3.0 ℓ (3 1/8 qt)

2. After refilling oil, check oil level. Set a new gasket on the filler plug, then install it in the transaxle body.

Filler plug : 10 - 19 N·m (1.0 - 2.0 kg·m, 87 - 173 in·lb)

CAUTION:

Do not reuse gasket.

Checking
OIL LEAKAGE AND OIL LEVEL

- Check that oil is not leaking from transaxle.
- Check oil level from filler plug mounting hole as shown.

CAUTION:

Never start engine while checking oil level.

- Set a new gasket on the filler plug and install it in the transaxle body.

Filler plug : 10 - 19 N·m (1.0 - 2.0 kg·m, 87 - 173 in·lb)

CAUTION:

Do not reuse gasket.

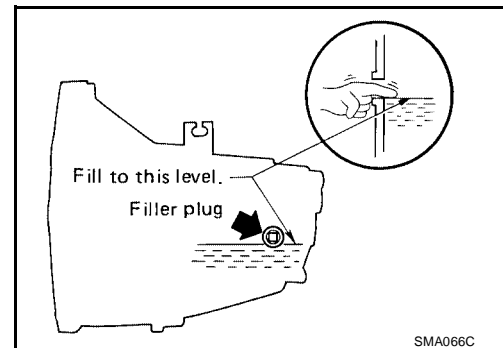

SIDE OIL SEAL

Removal and Installation

1. Remove drain plug and drain the oil from transaxle. Refer to [MT-11, "DRAINING"](#) .
2. Remove drive shafts. Refer to [FAX-14, "Removal"](#) .
3. Remove differential oil seal using Tool.

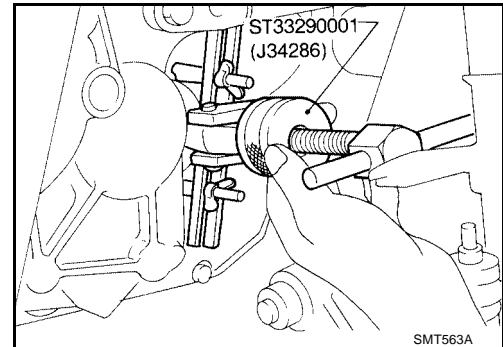

4. Install differential oil seal with a suitable tool.
 - Apply multi-purpose grease to seal lip of oil seal before installing.

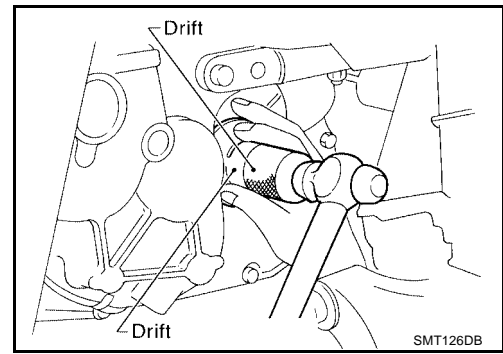

5. Install drive shafts. Refer to [FAX-16, "Installation"](#) .
 - Install differential oil seal so that dimensions "A" and "B" are within specifications.

Unit: mm (in)

Model	Dimension "A"	Dimension "B"
QG18DE (RS5F70A)	0.5 (0.020) or less	5.5 - 6.5 (0.217 - 0.256)

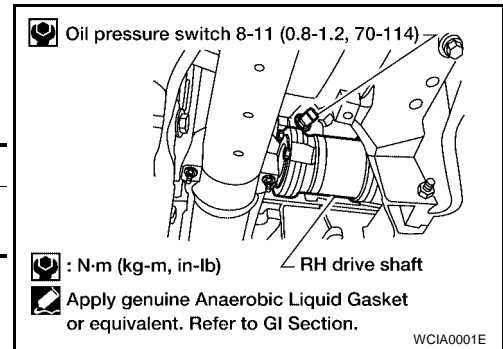

6. Refill the transaxle oil and install the drain plug with a new gasket. Refer to [MT-11, "FILLING"](#) .

POSITION SWITCH

Position Switch Check

NOTE:

For removal and installation of the switches. Refer to [MT-20, "CASE COMPONENTS"](#).

BACK-UP LAMP SWITCH

- Check continuity.

Gear position	Continuity
Reverse	Yes
Except reverse	No

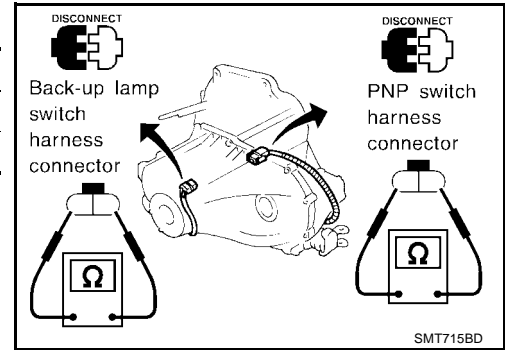

PNP SWITCH

- Check continuity.

Gear position	Continuity
Neutral	Yes
Except neutral	No

A
B
MT
D
E
F
G
H
I
J
K
L
M

CONTROL LINKAGE

Removal and Installation TRANSAXLE GEAR CONTROL

Refer to the illustration for the removal and installation procedure.

SEC. 341

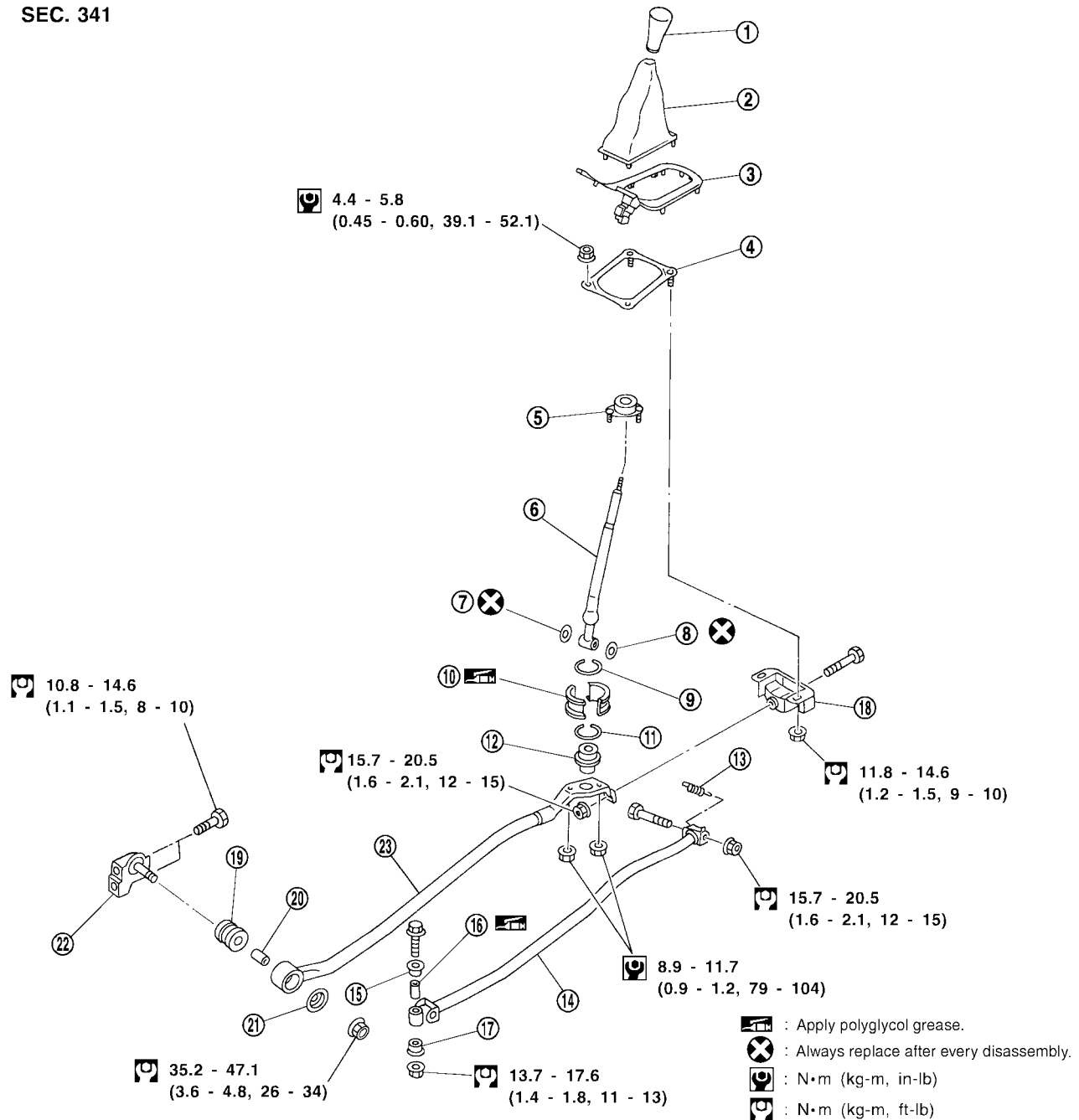

WCIA0135E

- | | | |
|--------------------------|-----------------|------------------|
| 1. Control lever knob | 2. Boot | 3. Finisher |
| 4. Control lever bracket | 5. Socket | 6. Control lever |
| 7. O-ring | 8. O-ring | 9. Ring spring |
| 10. Bearing seat | 11. Ring spring | 12. Seat |
| 13. Return spring | 14. Control rod | 15. Bushing |
| 16. Collar | 17. Bushing | 18. Bracket |
| 19. Bushing | 20. Collar | 21. Washer |
| 22. Support rod bracket | 23. Support rod | |

STRIKING ROD OIL SEAL

1. Remove transaxle control rod from yoke.
2. Remove retaining pin of yoke using Tool.
 - **Be careful not to damage boot.**

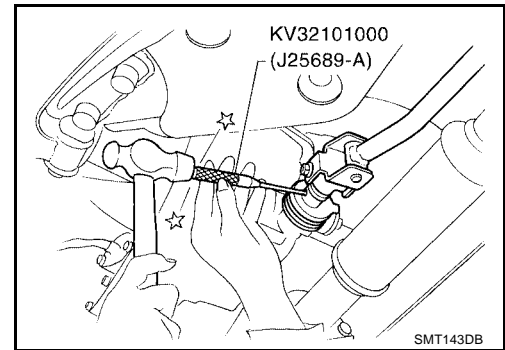

3. Remove the boot.
4. Remove striking rod oil seal with a suitable tool.

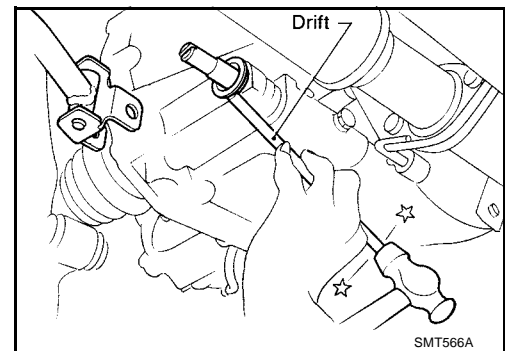

5. Install striking rod oil seal using Tool.
 - Apply multi-purpose grease to the seal lip of the oil seal before installing.

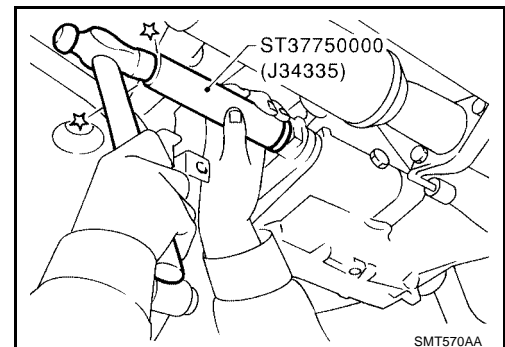

6. Install the boot.
7. Install yoke and retaining pin.
8. Connect the transaxle control rod to the yoke.

A
B
MT
D
E
F
G
H
I
J
K
L
M

TRANSAXLE ASSEMBLY

Removal and Installation REMOVAL

SEC. 320•391

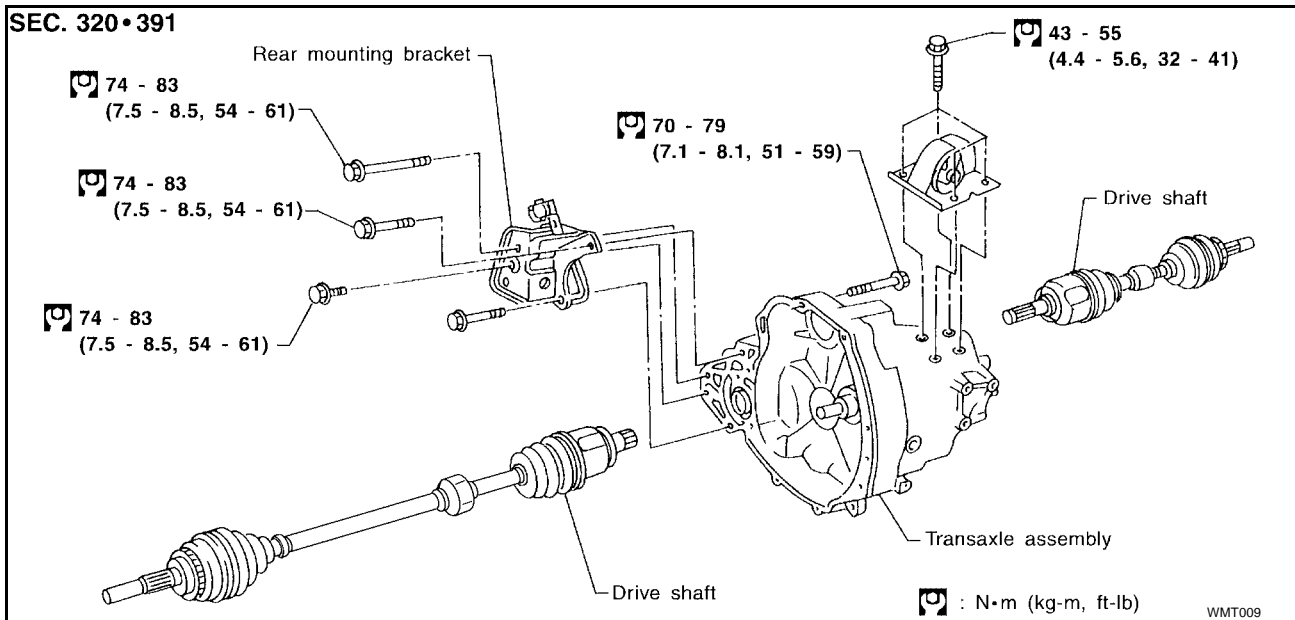

1. Remove battery negative terminal.
2. Remove air cleaner and air duct.

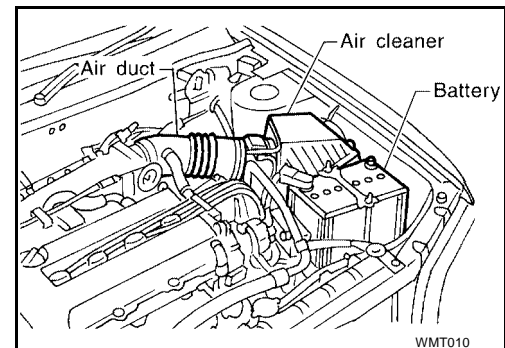

3. Remove clutch operating cylinder from transaxle. Refer to [CL-11, "Removal"](#).
4. Disconnect back-up lamp switch, VSS sensor, PNP switch, and ground harness connectors.
5. Remove starter motor from transaxle. Refer to [SC-20, "Removal"](#).

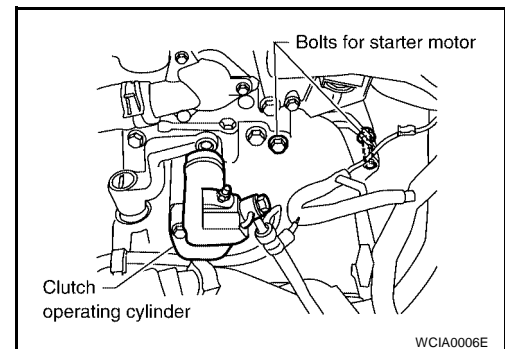

TRANSAXLE ASSEMBLY

[RS5F70A]

6. Remove air breather hose.

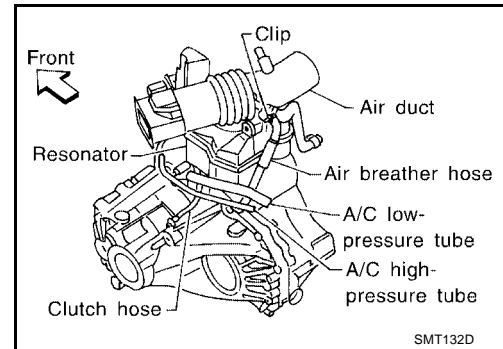

7. Remove shift control rod and support rod from transaxle.

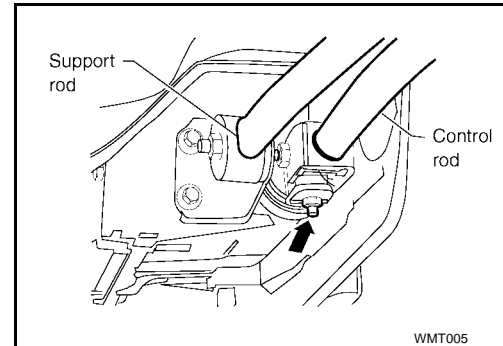

8. Remove the drain plug and drain gear oil from transaxle.
9. Remove the drive shafts from the transaxle. Refer to [FAX-14, "Removal"](#).
10. Support engine by placing a jack under oil pan as shown.

CAUTION:

Do not place jack under oil pan drain plug.

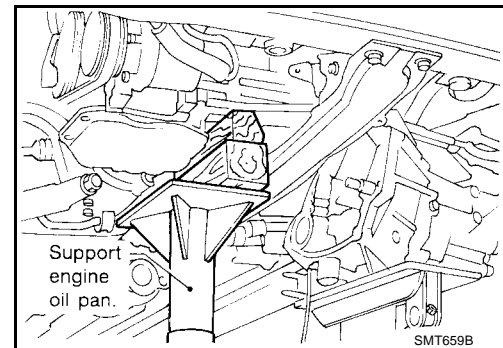

A
B
MT
D
E
F
G
H
I
J
K
L
M

TRANSAXLE ASSEMBLY

[RS5F70A]

11. Remove LH side and rear side mounting bolts.

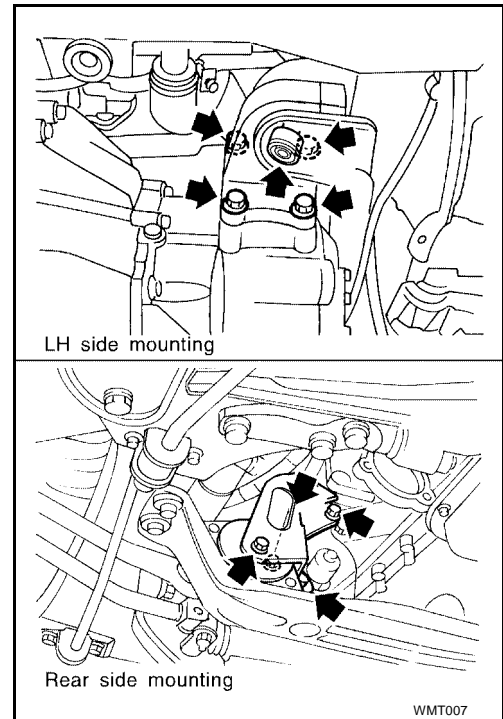

12. Remove lower housing bolts.

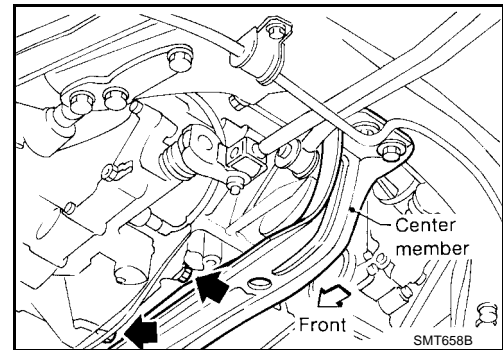

13. Remove bolts securing transaxle.

14. Lower transaxle while supporting it with a jack.

INSTALLATION

Installation is in the reverse order of removal.

- Tighten starter motor to transaxle bolts to specification.

Starter motor to transaxle bolts : 31 - 42 N·m (3.2 - 4.3 kg-m, 23 - 31 ft-lb)

- Tighten LH and rear mounts to specification.
- Install transaxle to engine, tighten the bolts to specification.

Bolt No.	Tightening torque N·m (kg-m, ft-lb)	" ℓ "mm (in)
1	30 - 40 (3.1 - 4.1, 22 - 30)	70 (2.76)
2	30 - 40 (3.1 - 4.1, 22 - 30)	80 (3.15)
3	30 - 40 (3.1 - 4.1, 22 - 30)	30 (1.18)
4*	16 - 21 (1.6 - 2.1, 12 - 15)	25 (0.98)
Front gusset A to engine	30 - 40 (3.1 - 4.1, 22 - 30)	20 (0.79)
Rear gusset B to engine	16 - 21 (1.6 - 2.1, 12 - 15)	16 (0.63)

*: With gussets

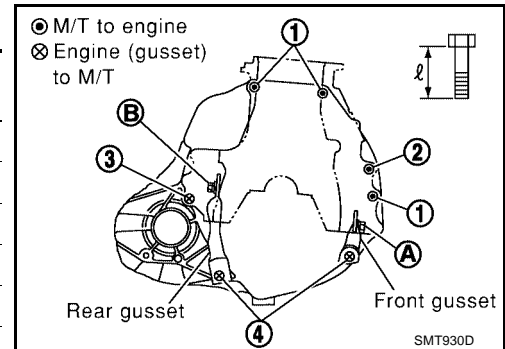

A
B
MT
D
E
F
G
H
I
J
K
L
M

TRANSAXLE ASSEMBLY

[RS5F70A]

ECS00570

Component Parts CASE COMPONENTS

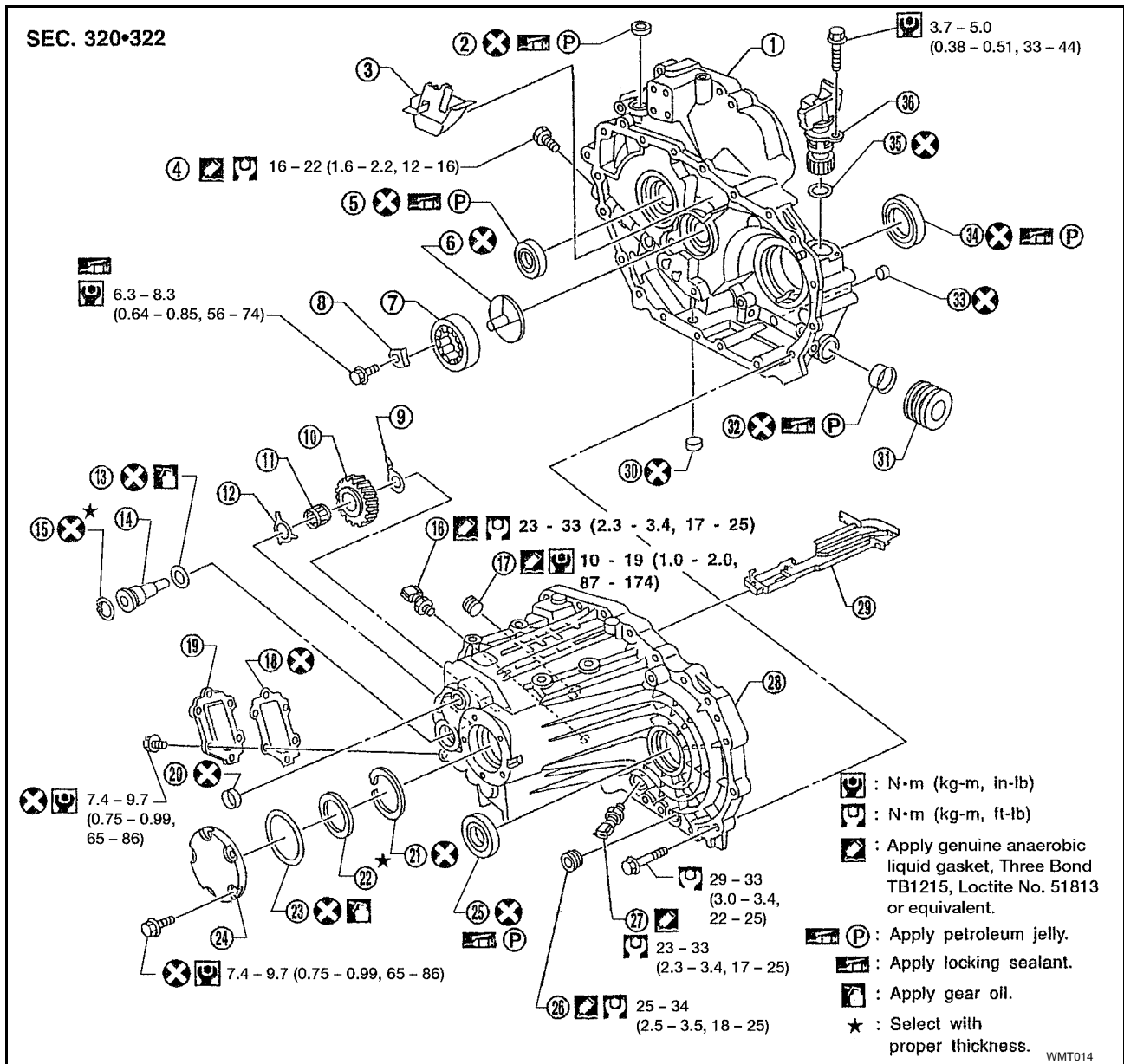

- | | | |
|-------------------------------------------|--------------------------------|-------------------------------------------|
| 1. Clutch housing | 2. Dust seal | 3. Oil pocket |
| 4. Check plug | 5. Input shaft oil seal | 6. Oil channel |
| 7. Mainshaft front bearing | 8. Bearing retainer | 9. Reverse idler gear front thrust washer |
| 10. Reverse idler gear | 11. Reverse idler gear bearing | 12. Reverse idler gear rear thrust washer |
| 13. O-ring | 14. Reverse idler gear shaft | 15. Snap ring |
| 16. Back-up lamp switch | 17. Filler plug | 18. Side cover gasket |
| 19. Side cover | 20. Welch plug | 21. Mainshaft bearing snap ring |
| 22. Mainshaft rear bearing adjusting shim | 23. O-ring | 24. Rear cover |
| 25. Differential oil seal | 26. Drain plug | 27. PNP switch |
| 28. Transmission case | 29. Oil gutter | 30. Welch plug |
| 31. Boot | 32. Striking rod oil seal | 33. Welch plug |
| 34. Differential oil seal | 35. O-ring | 36. Speedometer pinion |

GEAR COMPONENTS

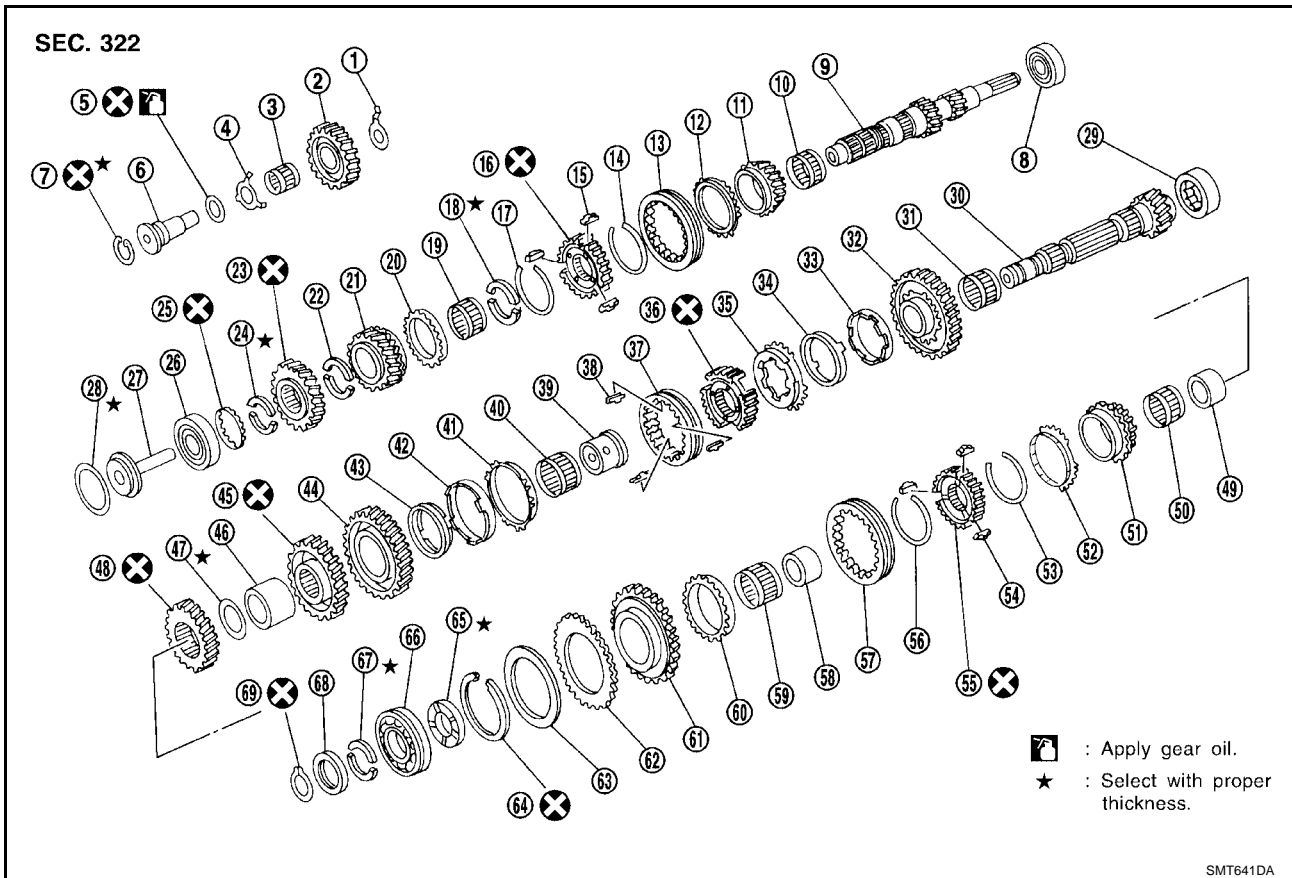

- | | | |
|---------------------------------------------|---------------------------------|--------------------------------|
| 1. Reverse idler gear front thrust washer | 2. Reverse idler gear | 3. Reverse idler gear bearing |
| 4. Reverse idler gear rear thrust washer | 5. O-ring | 6. Reverse idler gear shaft |
| 7. Snap ring | 8. Input shaft front bearing | 9. Input shaft |
| 10. 3rd gear needle bearing | 11. 3rd input gear | 12. 3rd gear baulk ring |
| 13. Coupling sleeve | 14. Spread spring | 15. Shifting insert |
| 16. 3rd & 4th synchronizer hub | 17. Spread spring | 18. 4th gear C-ring |
| 19. 4th gear needle bearing | 20. 4th gear baulk ring | 21. 4th input gear |
| 22. 5th gear front C-ring | 23. 5th input gear | 24. 5th gear rear C-ring |
| 25. C-ring holder | 26. Input shaft rear bearing | 27. Oil channel |
| 28. Input shaft rear bearing adjusting shim | 29. Mainshaft front bearing | 30. Mainshaft |
| 31. 1st gear needle bearing | 32. 1st main gear | 33. 1st inner baulk ring |
| 34. 1st synchronizer cone | 35. 1st outer baulk ring | 36. 1st & 2nd synchronizer hub |
| 37. Coupling sleeve | 38. Insert spring | 39. 2nd gear bushing |
| 40. 2nd gear needle bearing | 41. 2nd gear outer baulk ring | 42. 2nd gear synchronizer cone |
| 43. 2nd inner baulk ring | 44. 2nd main gear | 45. 3rd main gear |
| 46. Spacer | 47. Mainshaft adjusting shim | 48. 4th main gear |
| 49. 5th gear bushing | 50. 5th gear needle bearing | 51. 5th main gear |
| 52. 5th gear baulk ring | 53. Spread spring | 54. Shifting insert |
| 55. 5th & reverse synchronizer hub | 56. Spread spring | 57. Coupling sleeve |
| 58. Reverse gear bushing | 59. Reverse gear needle bearing | 60. Reverse gear baulk ring |
| 61. Reverse main gear | 62. Sub-gear | 63. Sub-gear washer |
| 64. Snap ring | 65. Mainshaft thrust washer | 66. Mainshaft rear bearing |
| 67. Mainshaft C-ring | 68. C-ring holder | 69. Snap ring |

SMT641DA

FINAL DRIVE COMPONENTS

SEC. 322

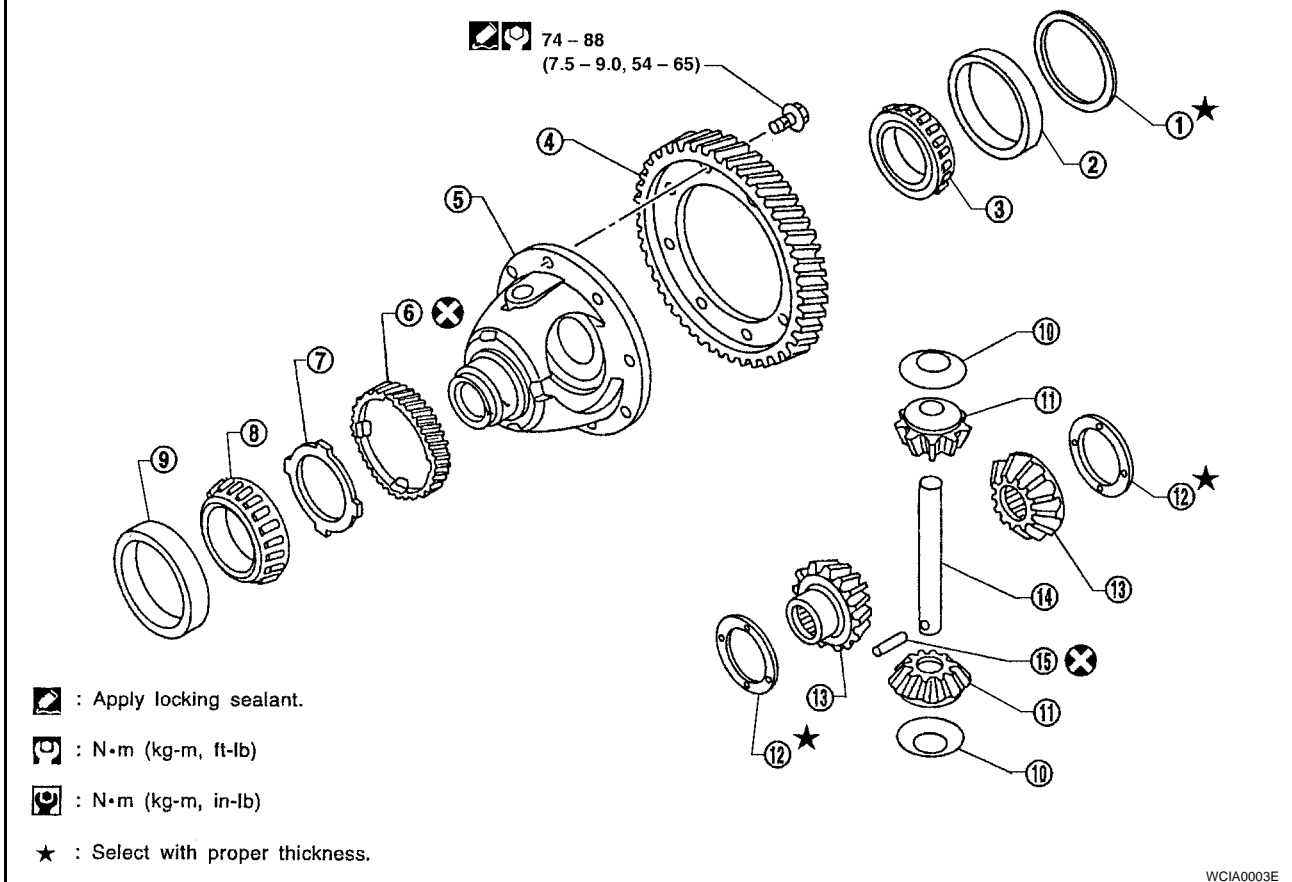

- | | | |
|---------------------------------------------|-----------------------------------------|-----------------------------------------|
| 1. Differential side bearing adjusting shim | 2. Differential side bearing outer race | 3. Differential side bearing |
| 4. Final gear | 5. Differential case | 6. Speedometer drive gear |
| 7. Speedometer stopper | 8. Differential side bearing | 9. Differential side bearing outer race |
| 10. Pinion mate thrust washer | 11. Pinion mate gear | 12. Side gear thrust washer |
| 13. Side gear | 14. Pinion mate shaft | 15. Lock pin |

Disassembly and Assembly

DISASSEMBLY

Transaxle Case

1. Remove back-up lamp switch, PNP switch, drain plug, and filler plug from transaxle case.

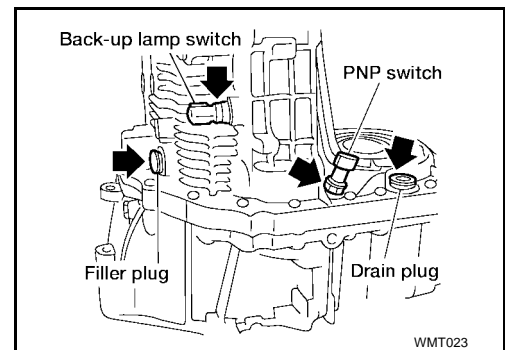

TRANSAXLE ASSEMBLY

[RS5F70A]

2. Remove snap ring from reverse idler shaft as shown.
3. Remove side cover and rear cover from case.

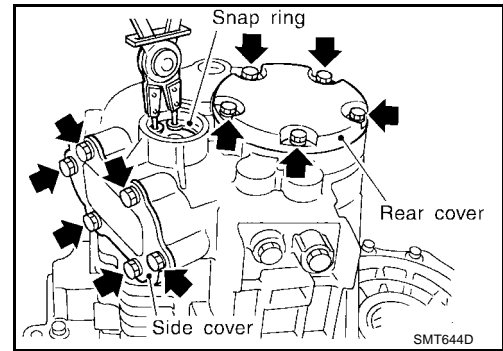

4. Remove O-ring and mainshaft bearing adjusting shim.
5. Remove reverse idler gear shaft.
 - a. Attach bolt (M6) to thread of reverse idler gear shaft end as shown.
 - b. Pull out the attached bolt (M6), and remove reverse idler gear shaft from case.

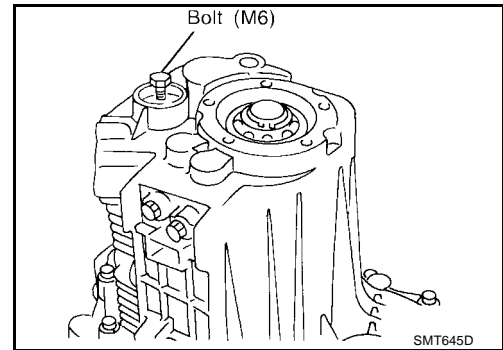

6. Remove reverse idler gear, thrust washer (front, rear), and bearing from case.
7. Remove mainshaft rear bearing snap ring from case.

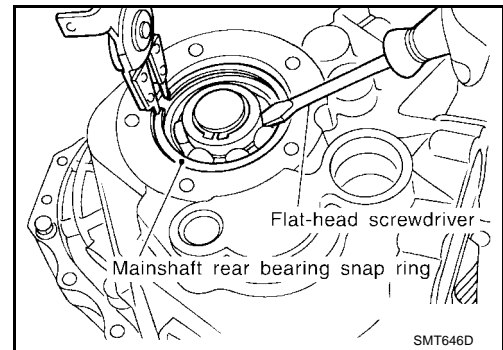

8. Remove check plugs, springs, and check balls from case.

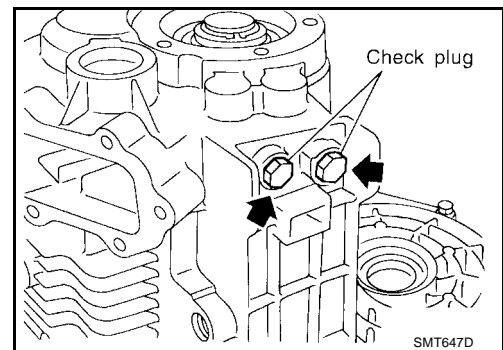

TRANSAXLE ASSEMBLY

[RS5F70A]

9. Remove transaxle case mounting bolts.

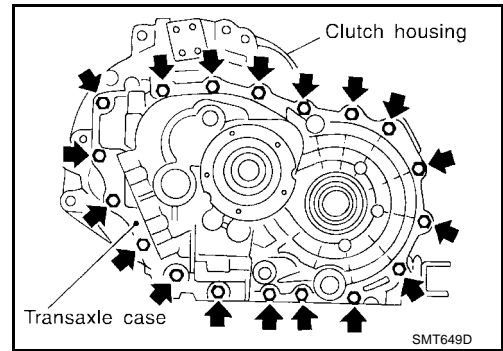

10. Remove input shaft rear bearing adjusting shim from transaxle case.
11. Remove oil gutter from transaxle case.

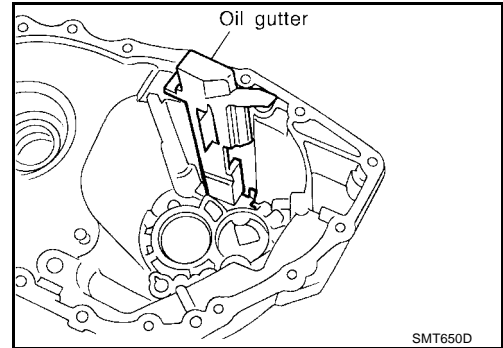

12. Remove differential side bearing outer race and adjusting shim from transaxle case using Tool.

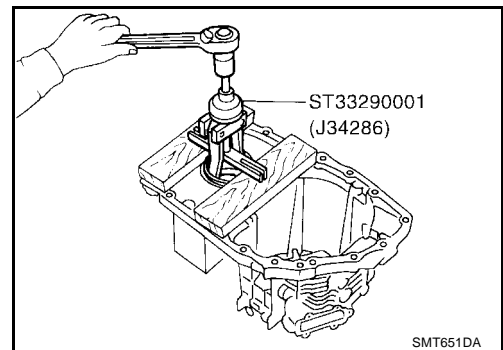

13. Remove differential oil seal from transaxle case using Tool.

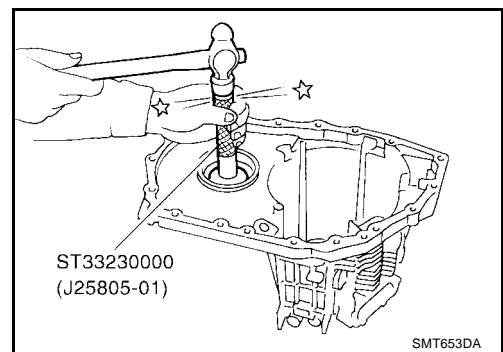

A
B
MT
D
E
F
G
H
I
J
K
L
M

14. Remove welch plugs from transaxle case using Tool.

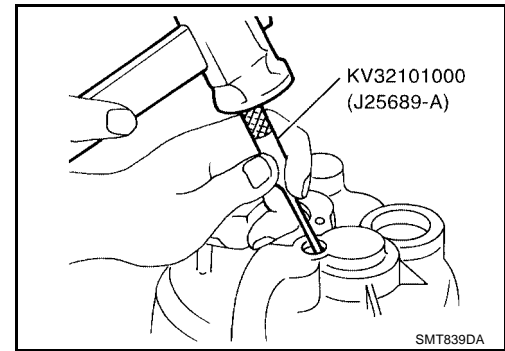

Clutch Housing

1. Remove transaxle case from clutch housing.
2. Remove check plugs, check springs, check pins, and check balls from housing.

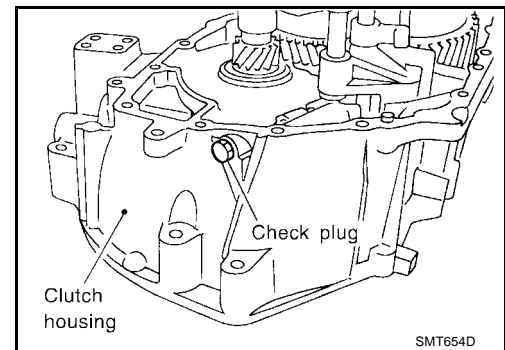

3. Remove 3rd & 4th bracket retaining pin using Tool.

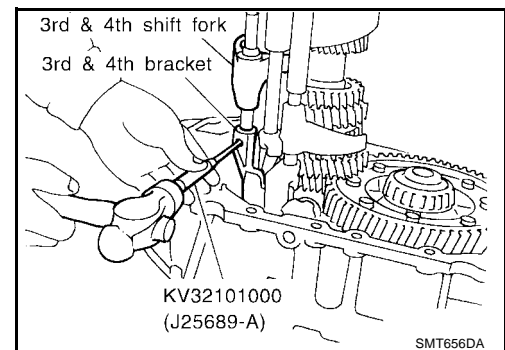

4. Remove 3rd & 4th shift fork stopper ring.

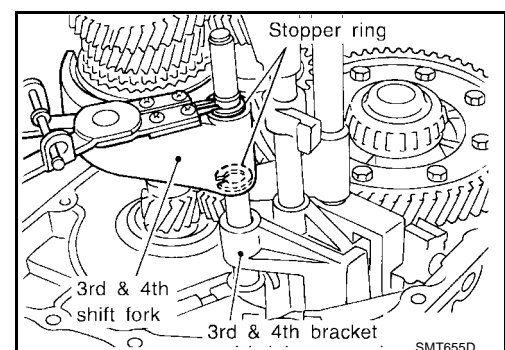

5. Remove 3rd & 4th fork rod.
6. Remove 3rd & 4th shift fork and bracket.

TRANSAXLE ASSEMBLY

[RS5F70A]

7. Remove interlock plunger and check ball.
8. Remove 5th & reverse bracket stopper ring.

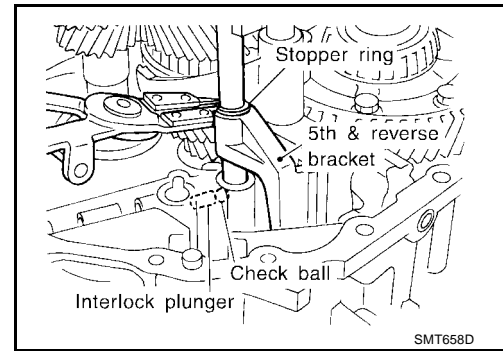

9. Remove retaining pins from 5th & reverse shift fork and 5th & reverse bracket using Tool.

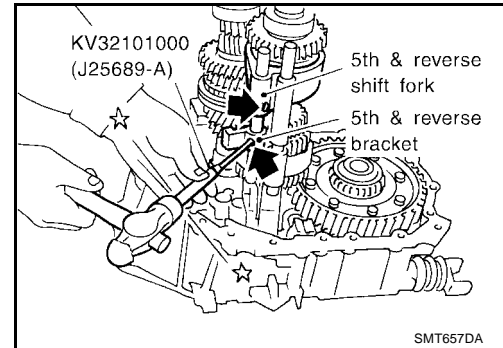

10. Remove 5th & reverse fork rod.
11. Remove interlock pin from 5th & reverse fork rod using Tool.
12. Remove reverse switch bracket and 5th & reverse bracket.
13. Remove check ball from housing.
14. Remove retaining pin for 1st & 2nd shift fork and 1st & 2nd bracket using Tool.

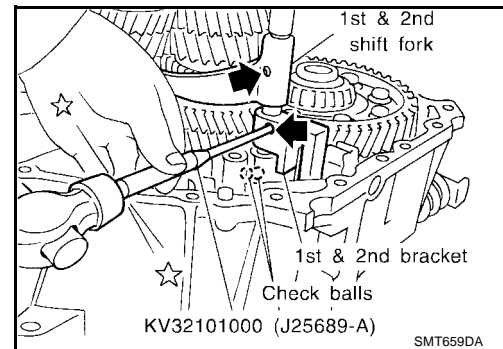

15. Remove 1st & 2nd fork rod.
16. Remove 5th & reverse and 1st & 2nd shift forks, and 1st & 2nd bracket.
17. Remove both input shaft and mainshaft assemblies from housing.

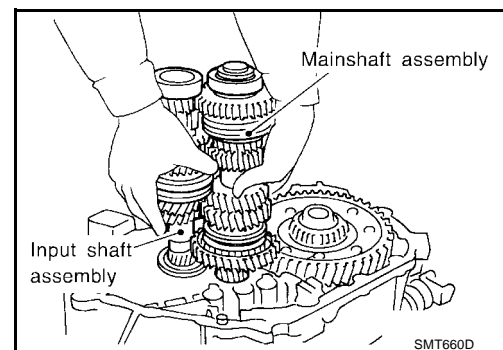

A

B

MT

D

E

F

G

H

I

J

K

L

M

TRANSAXLE ASSEMBLY

[RS5F70A]

- 18. Remove final drive assembly from housing.
- 19. Remove oil pocket from housing.

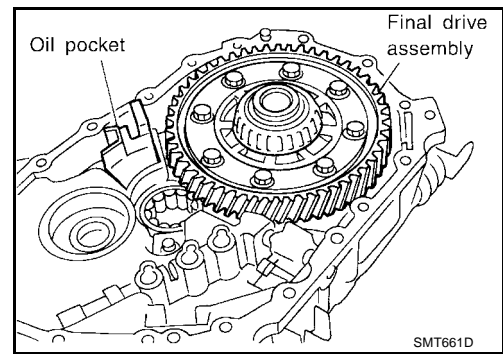

- 20. Remove mainshaft bearing retainer from housing.
- 21. Cut off oil channel using a cutter as shown.

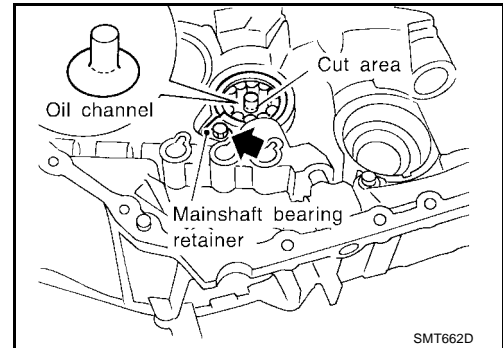

- 22. Remove mainshaft front bearing from housing using Tool.

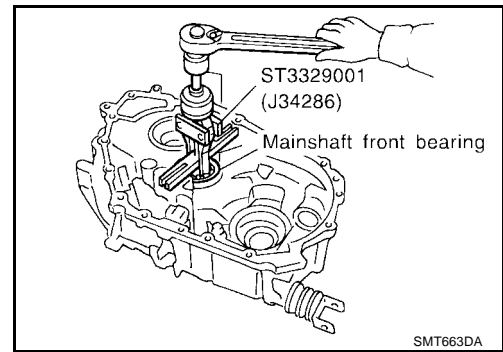

- 23. Using a magnet or other suitable tool, remove selector pin from selector shaft.

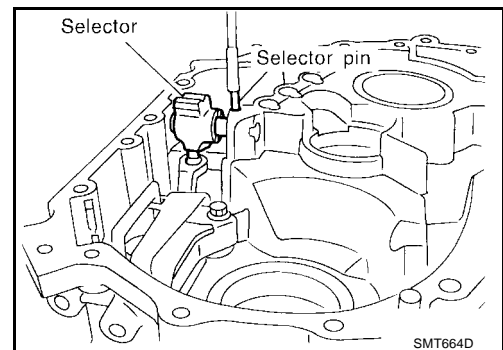

- 24. Remove selector shaft and plug, then remove selector using Tool.

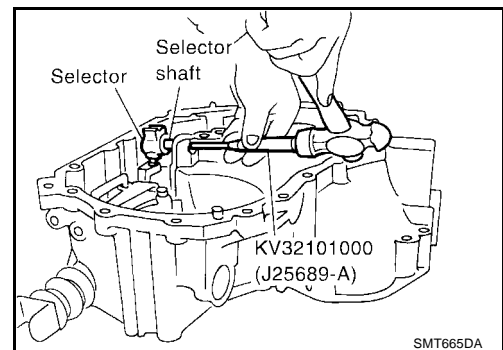

TRANSAXLE ASSEMBLY

[RS5F70A]

25. Remove reamer bolts, then remove select check leaf spring, return spring, steel ball, reverse gate, selector arm, bearing, and bushing.

CAUTION:

Be careful not to lose the steel ball.

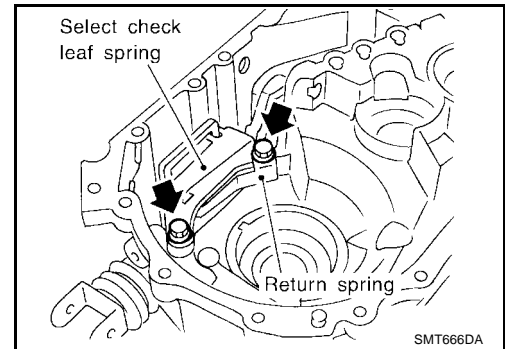

26. Remove retaining pin and plug from striking lever using Tool.

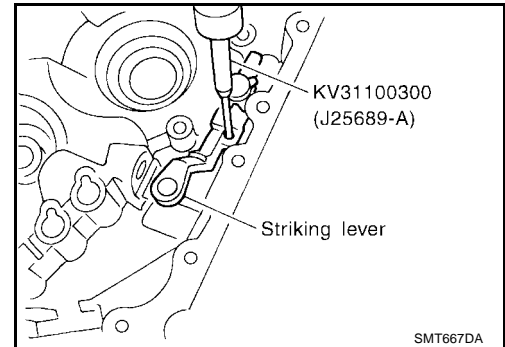

27. Remove striking rod, then striking lever from housing.
28. Using a flat-head screwdriver or other suitable tool, remove dust seal, input shaft oil seal, and striking rod oil seal from housing.

CAUTION:

When removing dust and oil seals, be careful not to damage mounting surfaces of dust seal and oil seal.

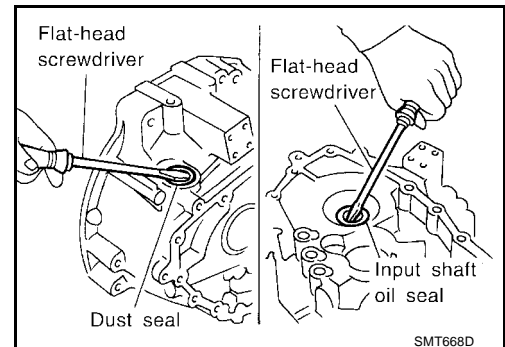

29. Remove differential oil seal from housing using Tool.

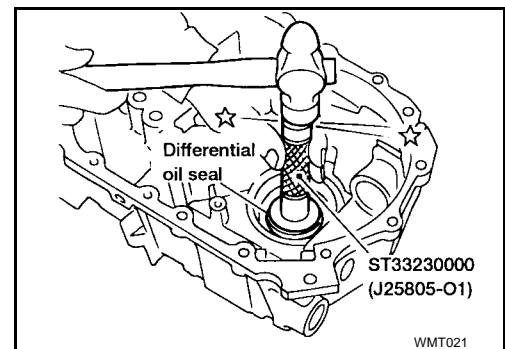

A
B
MT
D
E
F
G
H
I
J
K
L
M

30. Remove differential side outer race from housing using Tool.

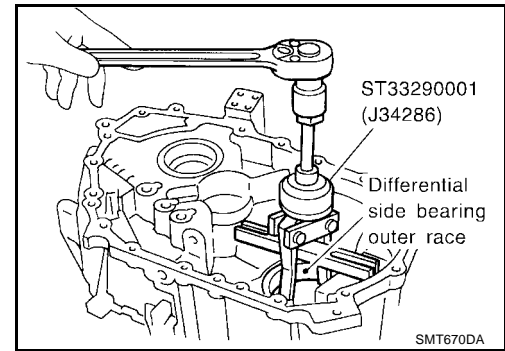

ASSEMBLY

Clutch Housing

1. Hammer the new striking rod oil seal into clutch housing as far as it will go using Tool.

CAUTION:

Do not reuse striking rod oil seal.

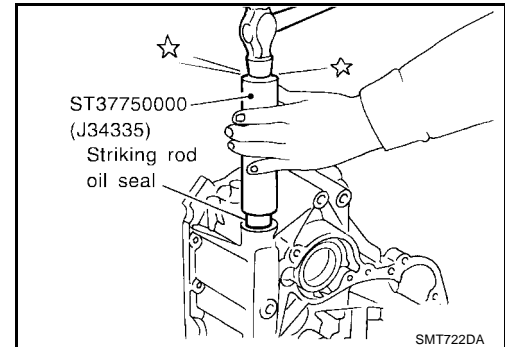

2. Hammer the differential oil seal into clutch housing with a suitable tool until it becomes flush with clutch housing end face.

CAUTION:

Do not reuse differential oil seal.

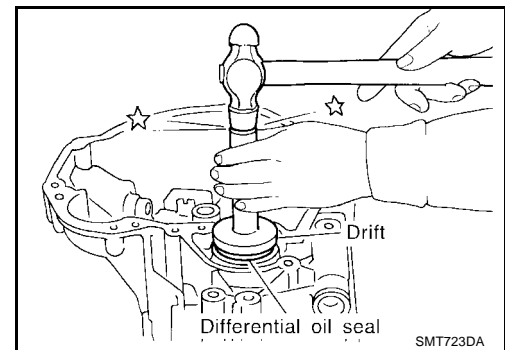

3. Hammer input shaft oil seal into clutch housing as far as it will go with a suitable tool.

CAUTION:

Do not reuse input shaft oil seal.

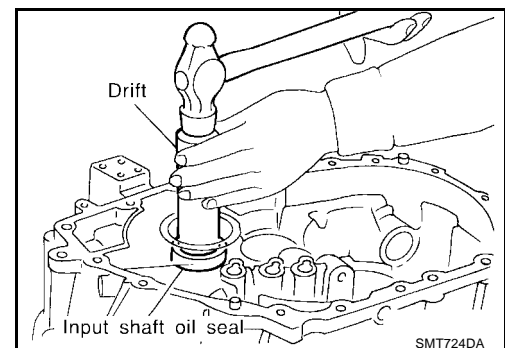

TRANSAXLE ASSEMBLY

[RS5F70A]

4. Hammer the dust seal into clutch housing as far as it will go using Tool.

CAUTION:

Do not reuse dust seal.

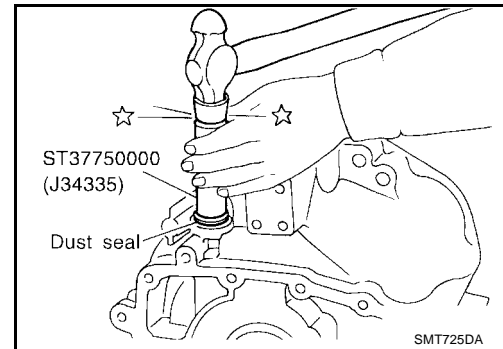

5. Install outer race of differential side bearing using Tool.

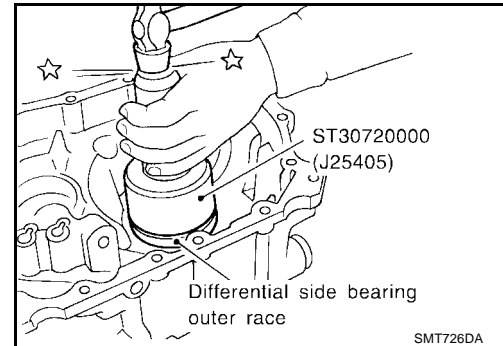

6. Install new oil channel (mainshaft).

CAUTION:

Pay attention to installation direction of oil channel.

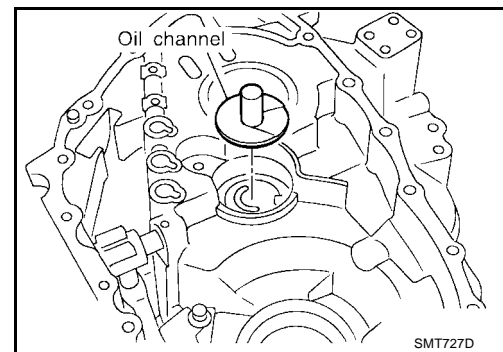

7. Align the notches on mainshaft front bearing and transaxle case. Then, install mainshaft front bearing with a suitable tool.

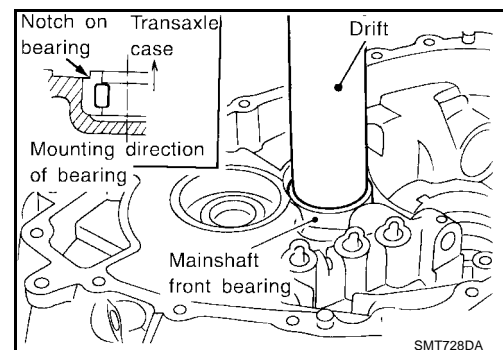

8. Install mainshaft bearing retainer, tighten bolt to specification.

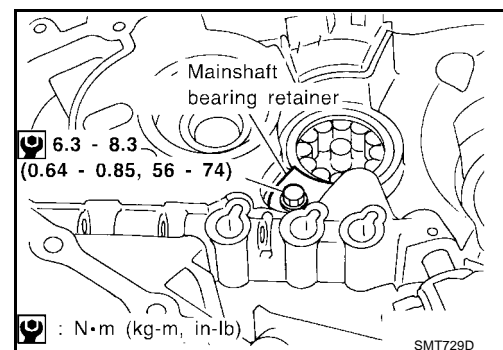

TRANSAXLE ASSEMBLY

[RS5F70A]

9. Attach boot, striking rod, and striking lever to clutch housing. Install new retaining pin for striking lever using Tool.

CAUTION:

- Before installing striking rod, wrap the end with a vinyl tape or similar product to prevent oil seal from being damaged.
- Do not reuse retaining pin.

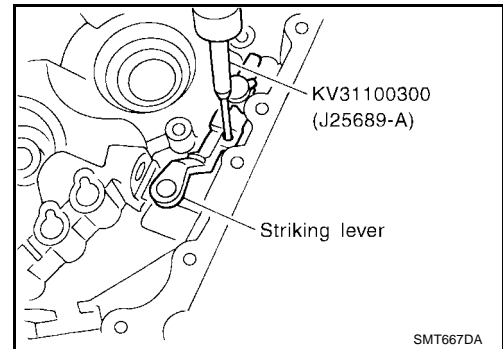

10. Hammer the new welch plug (striking lever side) with a general-purpose drift [OD: 12 mm (0.47 in)].

CAUTION:

Do not reuse welch plug.

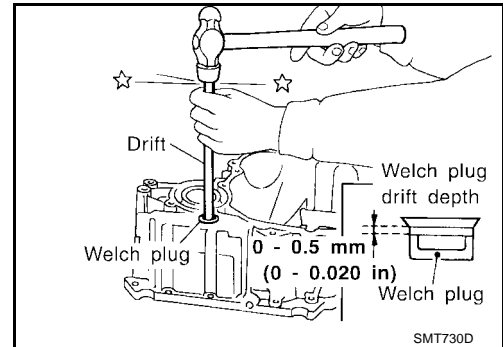

11. Install selector, selector shaft, and selector shaft pin into clutch housing.

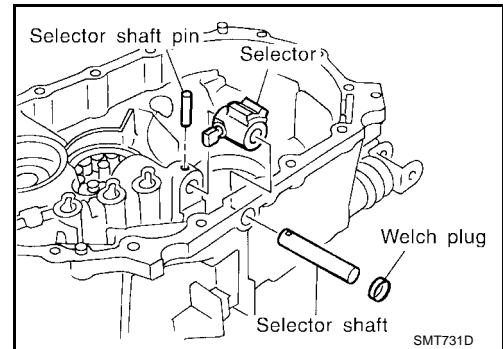

12. Hammer the new welch plug (selector shaft side) with a general-purpose drift [OD: 12 mm (0.47 in)].

CAUTION:

Do not reuse welch plug.

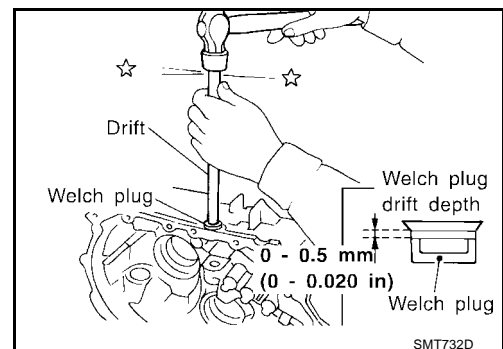

13. Install select check leaf spring, return spring, steel ball, reverse gate, selector arm, bushing, and return bearing.

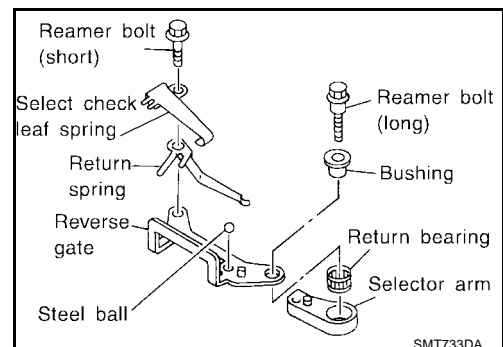

14. Tighten the two reamer bolts to specification.

CAUTION:

Use correct reamer bolts for each installation point, because each bolt has a different length.

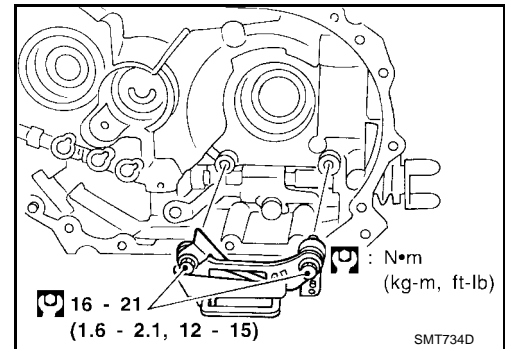

15. Install oil pocket.

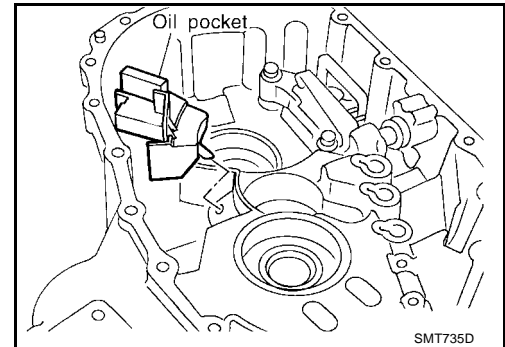

16. Install differential assembly, input shaft assembly, and mainshaft assembly into clutch housing.

CAUTION:

Be careful not to damage input shaft oil seal during installation of input shaft assembly.

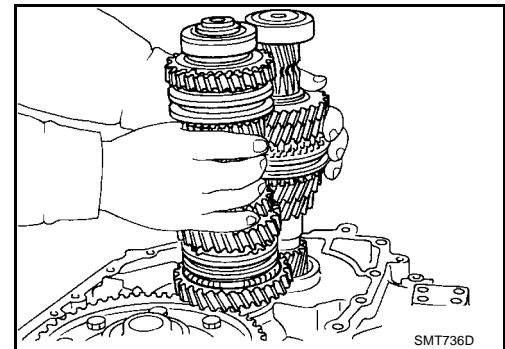

17. Install 5th & reverse shift fork.

18. Install 1st & 2nd shift fork, bracket, and fork rod.

19. Install retaining pin for 1st & 2nd bracket using Tool.

CAUTION:

Do not reuse retaining pin.

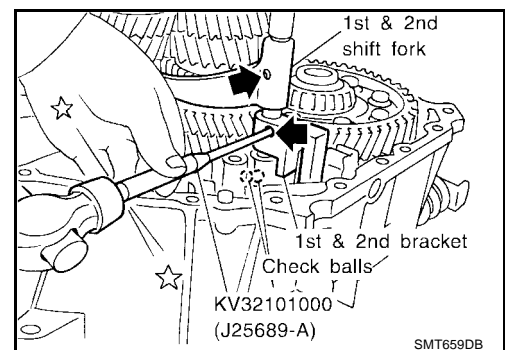

20. Install two check balls.

A
B
MT
D
E
F
G
H
I
J
K
L
M

TRANSAXLE ASSEMBLY

[RS5F70A]

21. Install interlock pin into 5th & reverse fork rod using Tool.
22. Install reverse switch bracket, 5th & reverse bracket, and fork rod.
23. Install new retaining pin for 5th & reverse shift fork and reverse switch bracket using Tool.

CAUTION:

Do not reuse retaining pin.

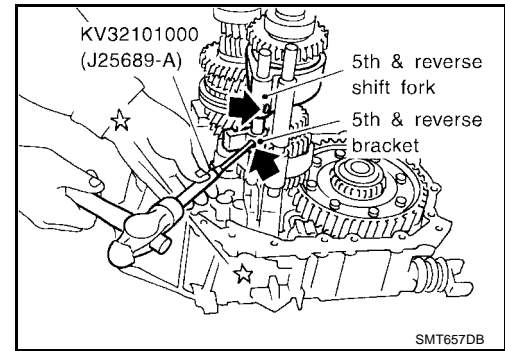

24. Install 5th & reverse bracket stopper ring.

CAUTION:

Do not reuse stopper pin.

25. Install check ball and interlock plunger.
26. Install 3rd & 4th shift fork, bracket, and fork rod.
27. Install 3rd & 4th bracket retaining pin using Tool.

CAUTION:

Do not reuse retaining pin.

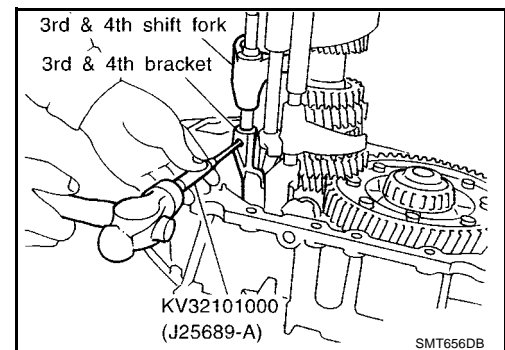

28. Install 3rd & 4th shift fork stopper ring.

CAUTION:

Do not reuse stopper ring.

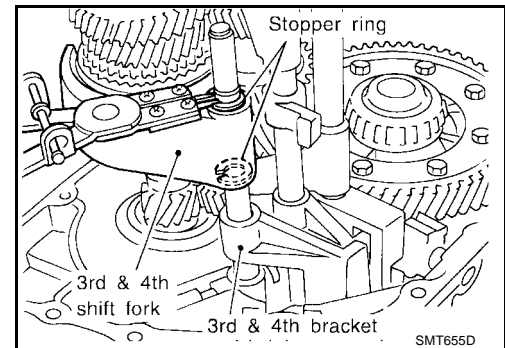

29. Install check ball, check pin, and check spring, and apply Anaerobic Liquid Gasket or equivalent onto the check plug. Then, tighten the check plug to specification. Refer to [MT-22, "SHIFT CONTROL COMPONENTS"](#).

Transaxle Case

1. Insert differential oil seal into differential case with a suitable tool until it becomes flush with case end face.

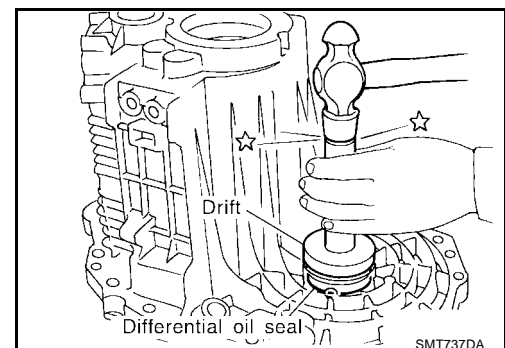

TRANSAXLE ASSEMBLY

[RS5F70A]

2. Install welch plug into transaxle case with a suitable tool.

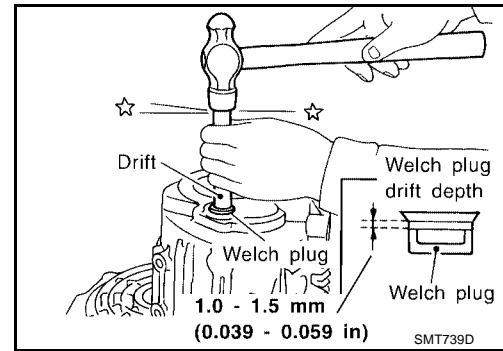

3. Calculate dimension "N" (thickness of adjusting shim) using the following procedure to satisfy specification of end play for differential side bearing.

End play : 0.15 - 0.21 mm (0.0059 - 0.0083 in)

Dimension "N" = (N1 - N2) + End play

N : Thickness of adjusting shim

N1 : Distance between clutch housing case end face and mounting face of adjusting shim

N2 : Distance between differential side bearing and transaxle case

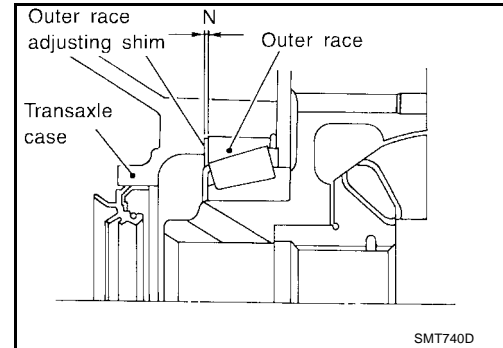

Use the "Available Shims" table for the available shim sizes. Refer to [MT-68, "Available Shims — Differential Side Bearing Preload and Adjusting Shim"](#).

- a. Using dial gauge and scale, measure dimension "N1" between clutch housing case end face and mounting face of adjusting shim.

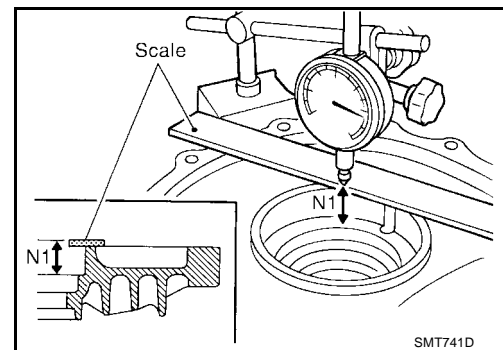

- b. Install outer race onto differential side bearing on final gear side. Holding the outer race horizontally by hand, rotate the final gear five times or more (for smooth movement of bearing roller).
- c. Using dial gauge and scale as shown, measure dimension "N2" between differential side bearing outer race and transaxle case end face.

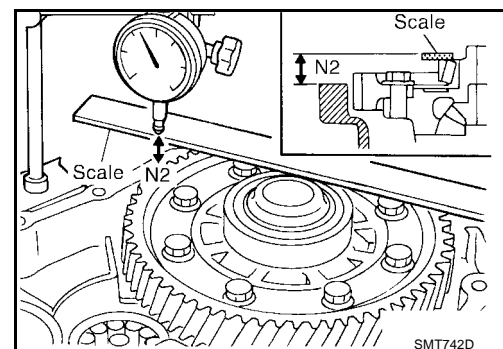

TRANSAXLE ASSEMBLY

[RS5F70A]

4. Install the selected shim and bearing outer race using Tool.

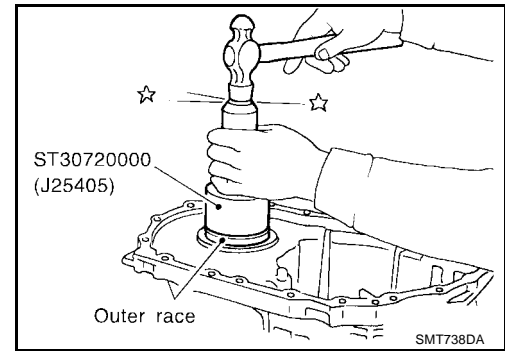

5. Measure the turning torque of the final drive assembly using Tool.

Turning torque of final drive assembly (New bearing) : 2.9 - 6.9 N-m (30 - 70 kg-cm, 26 - 61 in-lb)

- When the old bearing is used again, turning torque will be slightly less than the above.
- Make sure turning torque is close to the specified range.
- Changes in turning torque of final drive assembly per revolution should be within 1.0 N-m (10 kg-cm, 8.7 in-lb) without binding.

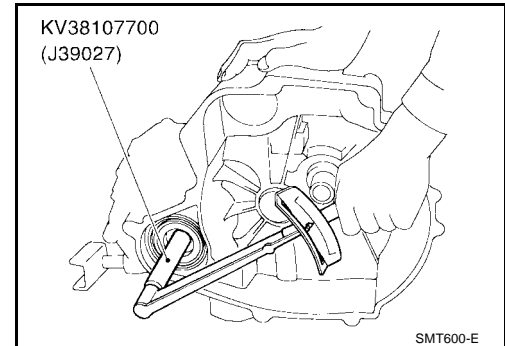

6. Calculate dimension "O" (thickness of adjusting shim) using the following procedure to satisfy specification of end play for input shaft rear bearing.

End play : 0 - 0.06 mm (0 - 0.0024 in)

Dimension "O" = (O1 - O2) + End play

O : Thickness of adjusting shim

O1 : Distance between transaxle case end face and mounting face of adjusting shim

O2 : Distance between clutch housing case end face and end face of input shaft rear bearing

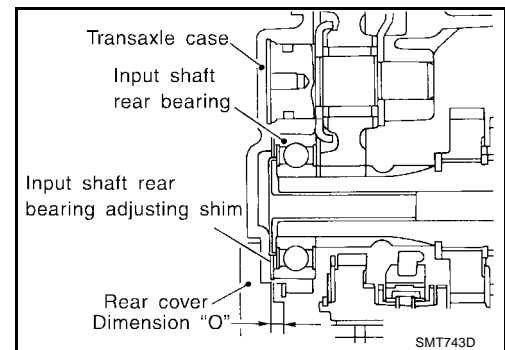

Use the "Available Shims" table for the available shim sizes. Refer to [MT-65, "Available Adjusting Shims"](#).

- a. Using block gauge, scale, and dial gauge, measure dimension "O1" between transaxle case end face and mounting face of adjusting shim.

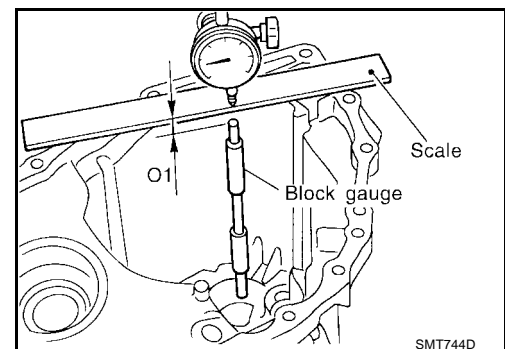

TRANSAXLE ASSEMBLY

[RS5F70A]

- b. Using block gauge, scale, and dial gauge as shown in the figure, measure dimension "O2" between clutch housing case end face and end face of input shaft rear bearing.

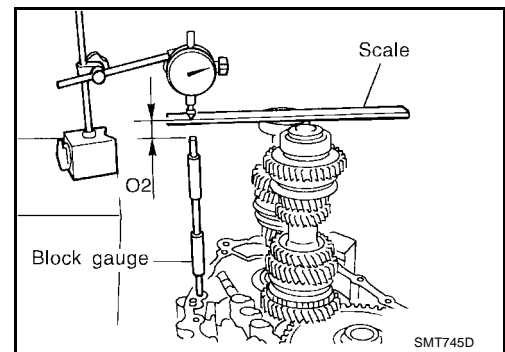

7. Install selected input shaft rear bearing adjusting shim onto input shaft.
8. Install oil gutter into transaxle case.

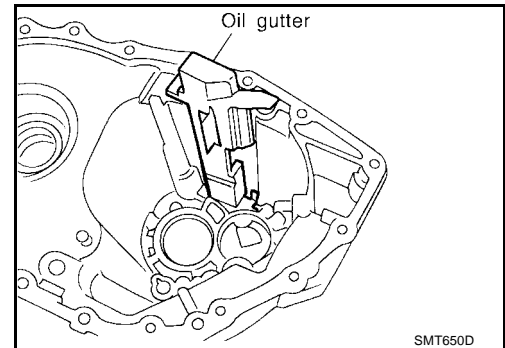

9. Clean mating surfaces of clutch housing and transaxle case. Check for cracks and damage, then apply sealant. Use Genuine Anaerobic Liquid Gasket or equivalent. Refer to [GI-44, "Recommended Chemical Products and Sealants"](#).

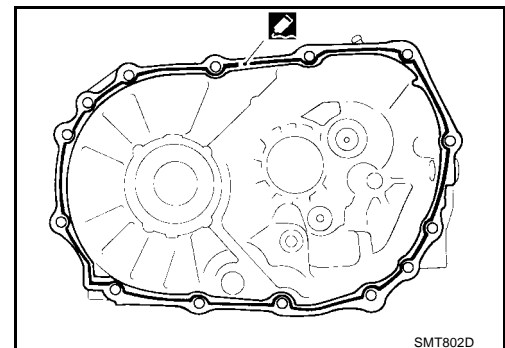

10. Install transaxle case onto clutch housing, and tighten mounting bolts with specified torque.

Transaxle case mounting bolts

: Refer to [MT-20, "CASE COMPONENTS"](#).

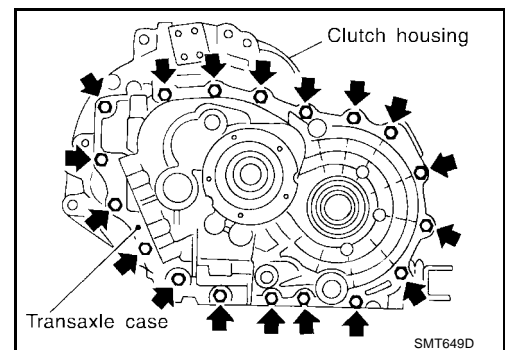

TRANSAXLE ASSEMBLY

[RS5F70A]

11. Apply sealant to threads of back-up lamp switch, PNP switch, and drain plug, then install them. Use Genuine Anaerobic Liquid Gasket or equivalent. Refer to [GI-44, "Recommended Chemical Products and Sealants"](#).

NOTE:

Fill the case with oil before installation of filler plug.

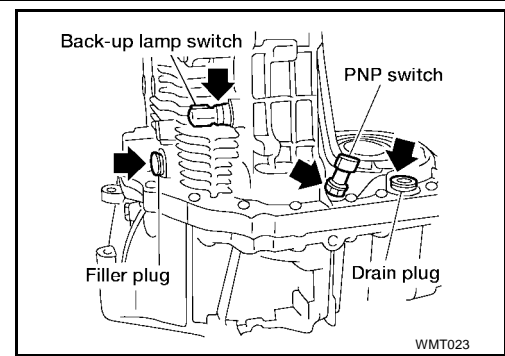

12. Install speedometer pinion assembly.

CAUTION:

Do not reuse O-ring.

13. Install check springs and check balls. Apply sealant to the thread on the check plug, and install it.

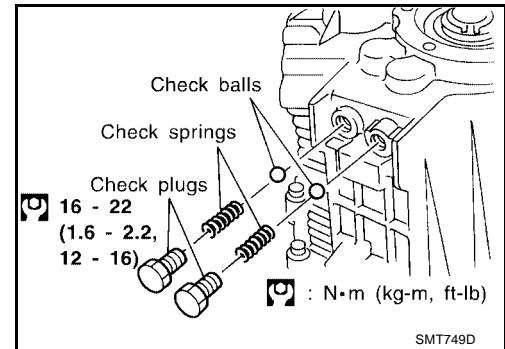

14. Calculate thickness of adjusting shim using the following procedure to satisfy specification of end play for mainshaft rear bearing.

- End play** : 0 - 0.06 mm (0 - 0.0024 in)
- Dimension "P"** = (P1 - P2) + End play
- P** : Thickness of adjusting shim
- P1** : Distance between transaxle case end face and mainshaft rear bearing
- P2** : Distance between adjusting shim end face of rear cover and transaxle mounting face

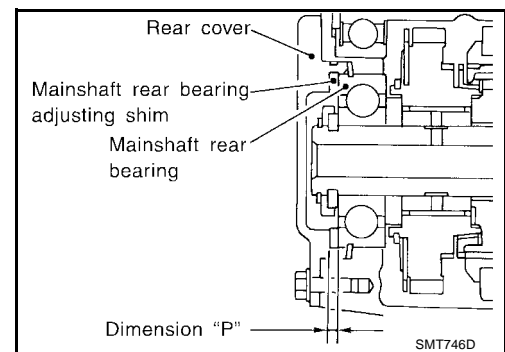

Use the "Available Shims" table for the available shim sizes. Refer to [MT-65, "Available Adjusting Shims"](#).

- a. Using dial gauge as shown in the figure, measure dimension "P1" between transaxle case end face and mainshaft rear bearing.

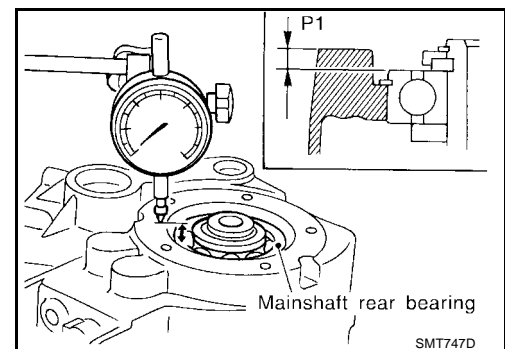

TRANSAXLE ASSEMBLY

[RS5F70A]

- b. Using dial gauge as shown in the figure, measure dimension "P2" between adjusting shim mounting face of rear cover and transaxle mounting face.

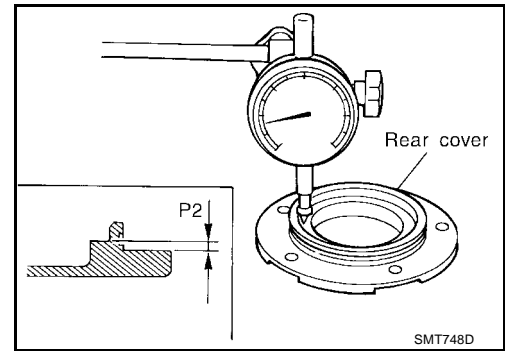

15. Using snap ring pliers and flat-head screwdriver as shown, install snap ring.

CAUTION:

Do not reuse snap ring.

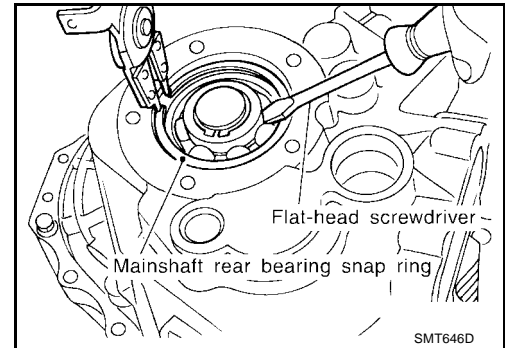

16. Install selected mainshaft adjusting shim.
17. Install reverse idler gear, O-ring, thrust washers (front and rear), and bearing onto reverse idler shaft.

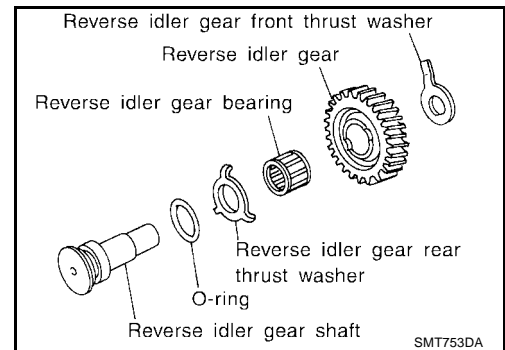

18. Install snap ring into transaxle case using snap ring pliers.

CAUTION:

- Do not reuse snap ring.
- Do not reuse O-ring.
- Before installation, apply gear oil to O-ring.

19. Using feeler gauge, measure the end play of snap ring, and select a snap ring suitable to satisfy the following specification.

End play : 0.05 - 0.25 mm (0.0020 - 0.0098 in)

Use the "Available Shims" table for the available shim sizes. Refer to [MT-64, "Available Snap Rings"](#).

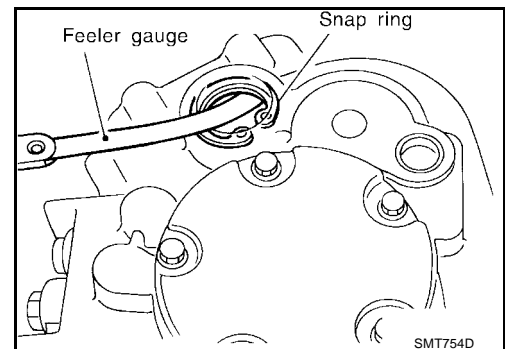

TRANSAXLE ASSEMBLY

[RS5F70A]

20. Install selected snap ring with a suitable tool.

CAUTION:
Do not reuse snap ring.

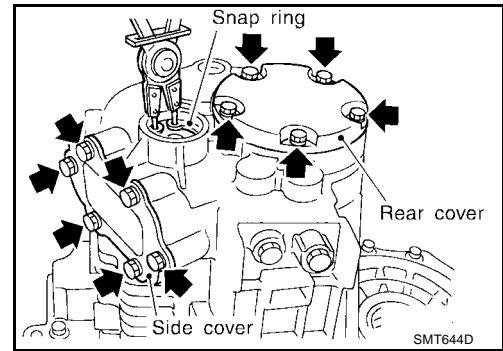

21. Apply gear oil to rear cover O-ring, and install rear cover, side cover gasket, and side cover. Then tighten mounting bolts with specified torque.

Use the "Available Shims" table for the available shim sizes. Refer to [MT-20, "CASE COMPONENTS"](#) .

CAUTION:
Do not reuse mounting bolts for rear cover and side cover.

INPUT SHAFT AND GEARS

Disassembly

1. Before disassembly, measure the end plays of 3rd and 4th input gears with a suitable tool. Refer to [MT-64, "Gear End Play"](#).
 - If end play is not within specification, disassemble and check the parts.

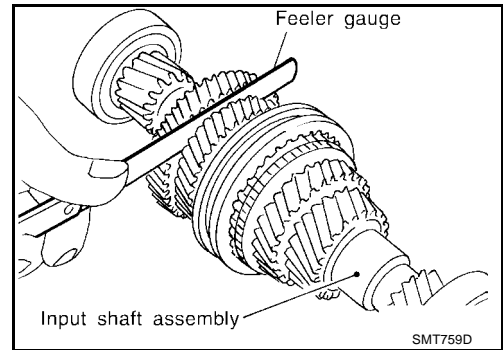

2. Remove oil channel from input shaft rear bearing.

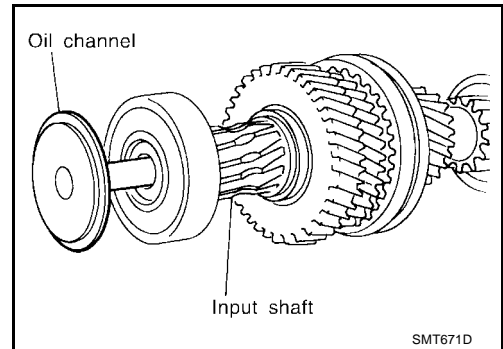

3. Press out input shaft rear bearing using Tool.

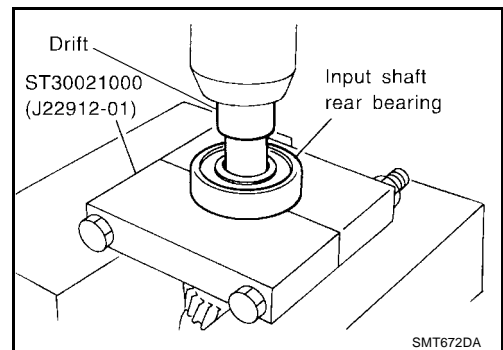

4. Remove C-ring holder.
5. Remove 5th gear rear C-ring.

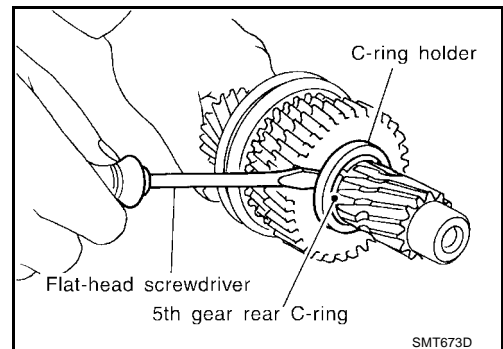

A
B
MT
D
E
F
G
H
I
J
K
L
M

INPUT SHAFT AND GEARS

[RS5F70A]

6. Remove 5th input gear from input shaft using Tool.
7. Remove 5th gear front C-ring.

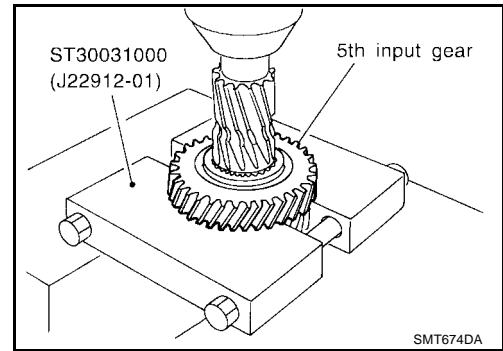

8. Remove 4th input gear, baulk ring, 4th gear needle bearing, and 4th gear C-ring from input shaft.
9. Press out both 3rd & 4th synchronizer hub assembly and 3rd input gear from input shaft using Tool.
10. Remove 3rd gear needle bearing.

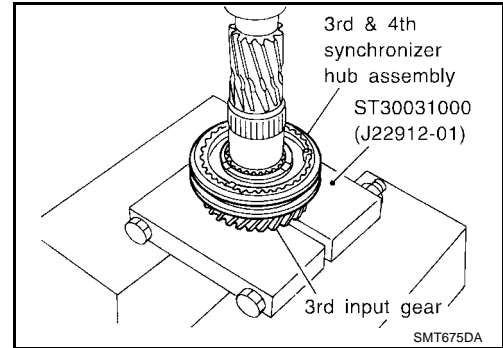

11. Press out input shaft front bearing from input shaft using Tool.

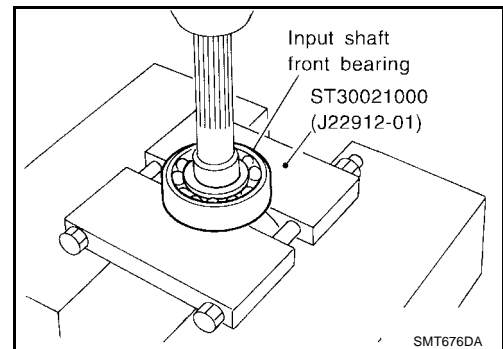

ECS005TR

Inspection GEAR AND SHAFT

- Check shaft for cracks, wear or bending.
- Check gears for excessive wear, chips or cracks.

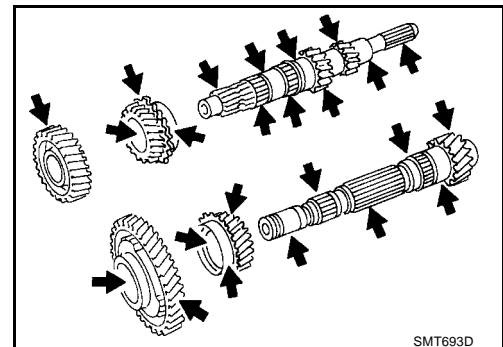

SYNCHRONIZERS

- Check spline area of coupling sleeves, hubs and gears for wear or cracks.
- Check baulk rings for cracks or deformation.
- Check insert springs for wear or deformation.

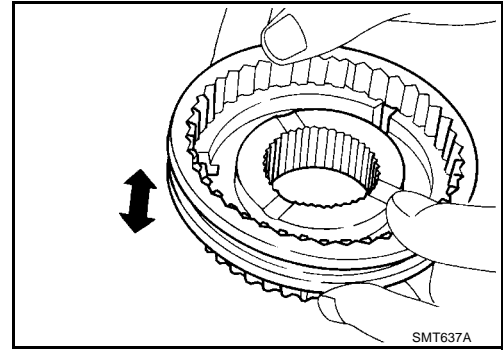

- If any crack, damage, or excessive wear is found on cam face of baulk ring or working face of insert, replace it.

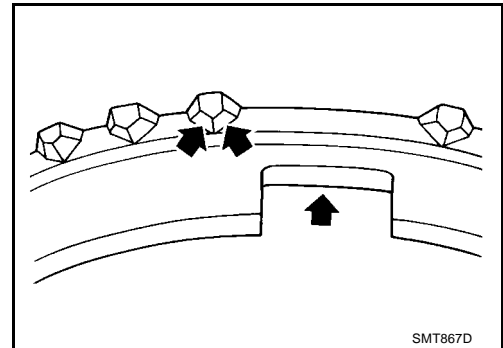

- Measure the movement (free play in dimension "L") of 3rd & 4th coupling sleeve with the end fixed and the other end lifted as shown in the figure. If the movement exceeds specification, replace the sleeve.

Coupling sleeve	Dimension "L"
3rd & 4th	0 - 0.95 mm (0 - 0.0374 in)

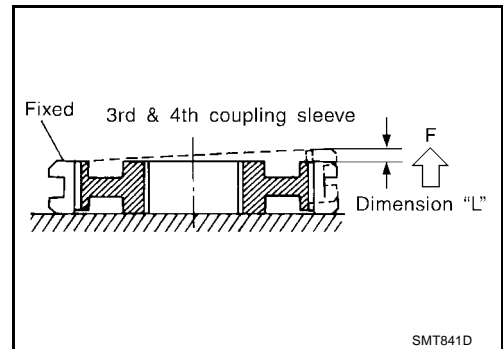

- Measure clearance between baulk ring and gear. Refer to [MT-64, "Clearance Between Baulk Ring and Gear"](#) .

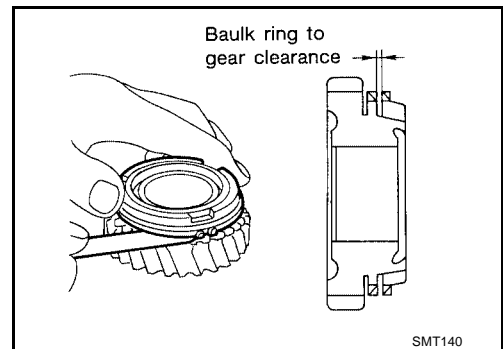

A
B
MT
D
E
F
G
H
I
J
K
L
M

BEARING

- Make sure bearings roll freely and are free from noise, cracks, pitting or wear.

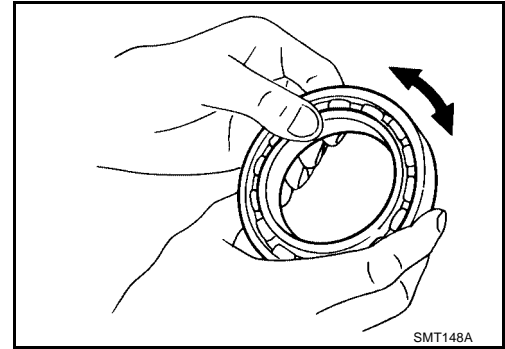

Assembly

1. Press on input shaft front bearing using Tool.

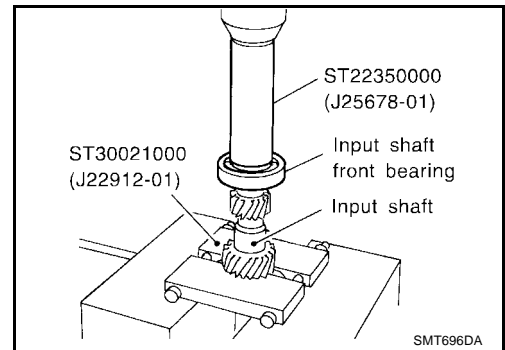

2. Install 3rd gear needle, 3rd input gear and 3rd gear baulk ring bearing to input shaft.
3. Install spread spring, shifting insert, and 3rd & 4th synchronizer hub onto 3rd & 4th coupling sleeve.

- Pay attention to the shape of spread spring and shifting insert for correct assembly. Do not install spread spring hook onto the same shifting insert.

CAUTION:

Do not reuse 3rd & 4th synchronizer hub.

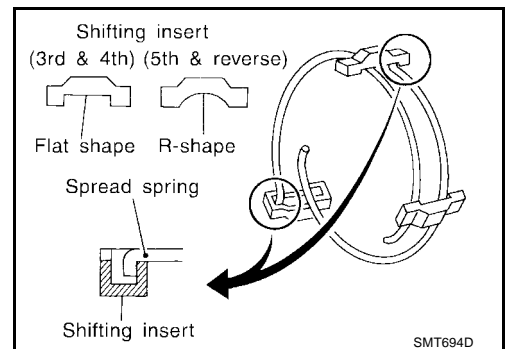

- Install synchronizer hub with its three grooves facing the front side (3rd input gear side).

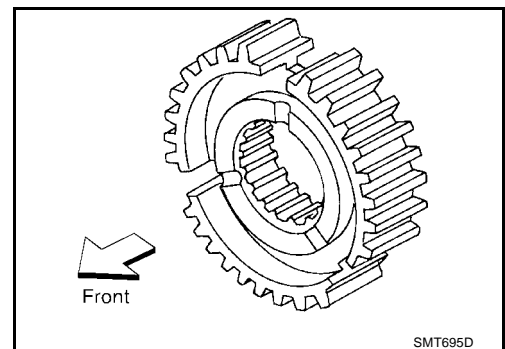

INPUT SHAFT AND GEARS

[RS5F70A]

- Install 3rd & 4th coupling sleeve with its chamfered surface facing the 4th input gear side.

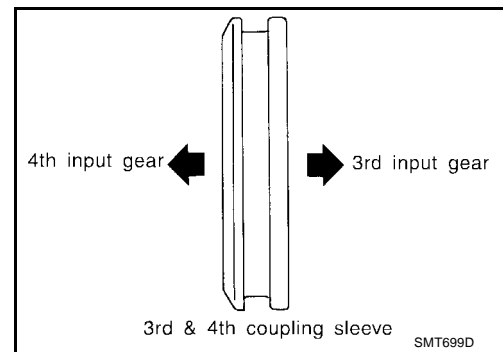

4. Position bearing replacer to the front side of input shaft front bearing.

- Align grooves of shifting insert and 3rd gear baulk ring. Then, press it onto 3rd & 4th synchronizer hub assembly using a drift.

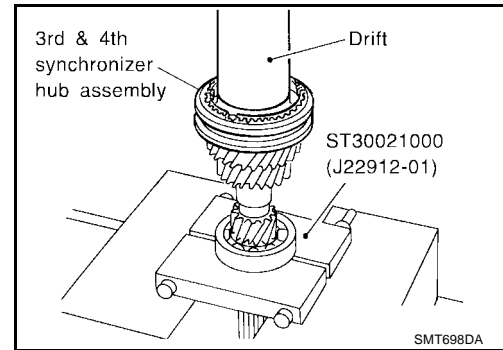

5. Install 4th gear C-ring onto input shaft using Tool.
6. Measure the end play of 3rd & 4th synchronizer hub with a suitable tool, and check if it is within allowable specification.

End play : 0 - 0.06 mm (0 - 0.0024 in)

7. If not within specification, adjust the end play by changing thickness of 4th (input) gear C-ring. Refer to [MT-64, "Available C-rings"](#).

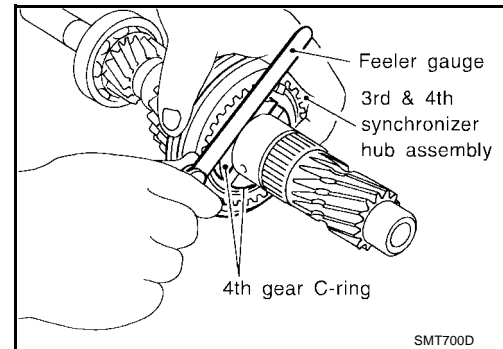

8. Install 4th gear needle bearing, 4th gear baulk ring, and 5th gear front C-ring.

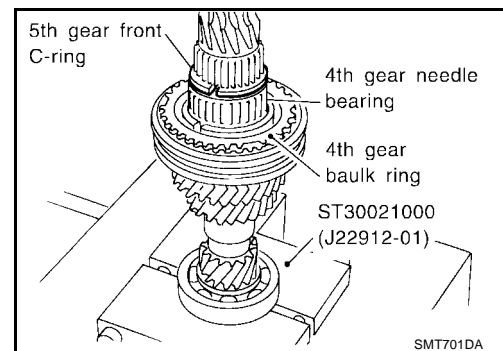

9. Install 4th input gear using Tool.

INPUT SHAFT AND GEARS

[RS5F70A]

10. Position 5th input gear as shown, to install it on input shaft.

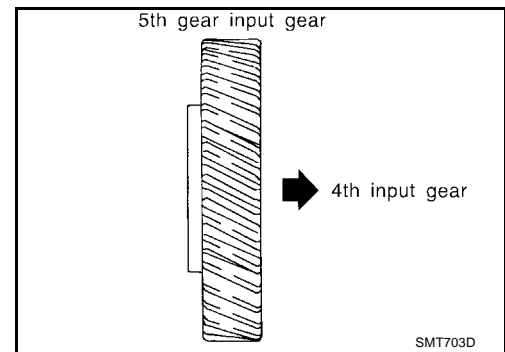

11. Install 5th input gear using Tool as shown.

CAUTION:
Do not reuse 5th input gear.

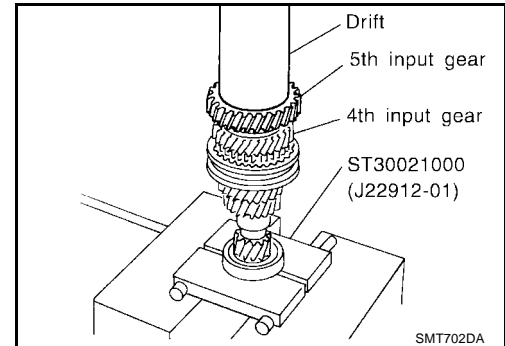

12. Install 5th gear rear C-ring onto input shaft using Tool.

13. Measure the end play of 5th input gear with a suitable tool, and check if it is within the allowable specification below.

End play : 0 - 0.06 mm (0 - 0.0024 in)

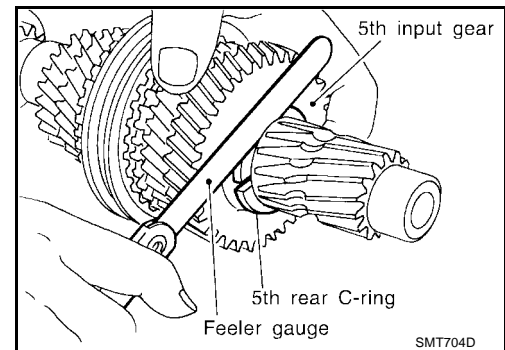

14. If not within specification, adjust the end play by changing thickness of the 5th (input gear) rear C-ring. Refer to [MT-64, "Available C-rings"](#).

15. Install C-ring holder onto 5th gear rear C-ring using Tool.

CAUTION:
Do not reuse C-ring holder.

16. Install input shaft rear bearing using Tool.

CAUTION:
Install input shaft rear bearing with its brown surface facing the input gear side.

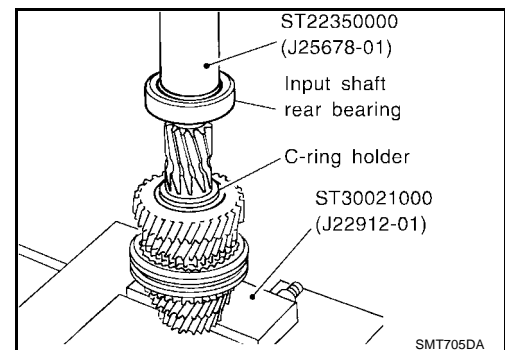

INPUT SHAFT AND GEARS

[RS5F70A]

17. Install oil channel onto input shaft.

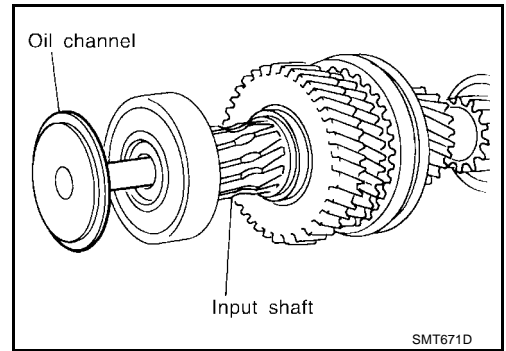

18. Measure gear end play as a final check. Refer to [MT-64, "Gear End Play"](#).

A
B
MT
D
E
F
G
H
I
J
K
L
M

MAINSHAFT AND GEARS

PFP:32241

Disassembly

ECS005TT

1. Before disassembly, measure gear end play with a suitable tool. Refer to [MT-64, "Gear End Play"](#) .
 - If end play is not within the specified limit, disassemble and check the parts.

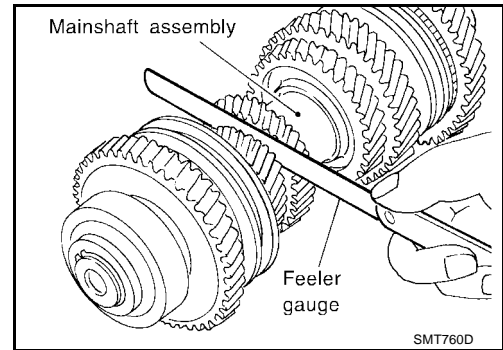

2. Remove snap ring with a suitable tool.

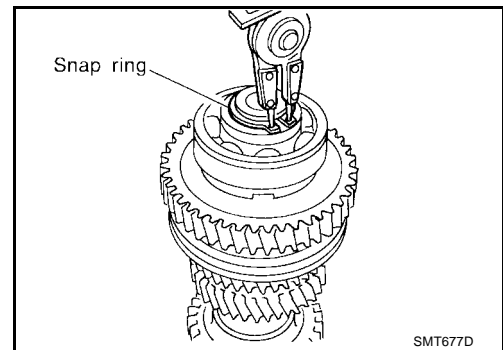

3. Remove C-ring holder and mainshaft C-ring.

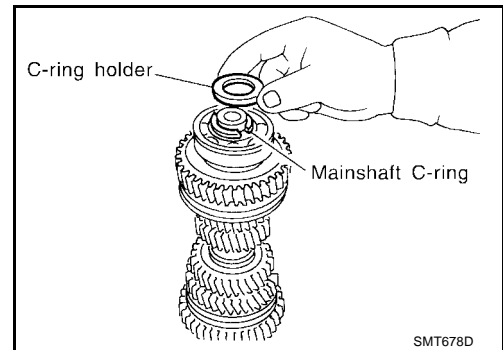

4. Press out mainshaft rear bearing from mainshaft using Tool.

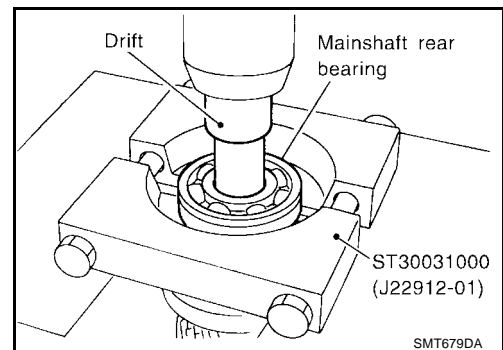

MAINSHAFT AND GEARS

[RS5F70A]

5. Remove mainshaft thrust washer.

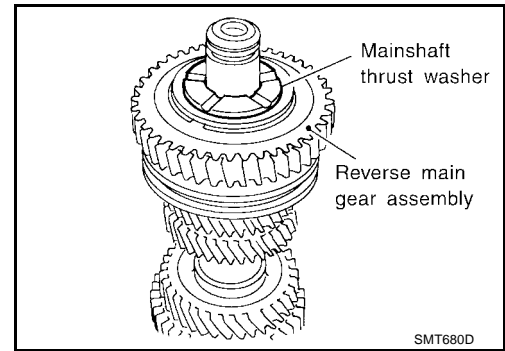

6. Remove snap ring from mainshaft. Then, remove reverse main gear assembly, reverse gear needle bearing, and reverse gear baulk ring.
7. Place bearing replacer between 5th & reverse synchronizer hub and 5th main gear, and press out both reverse gear bushing and 5th & reverse synchronizer assembly using Tool.

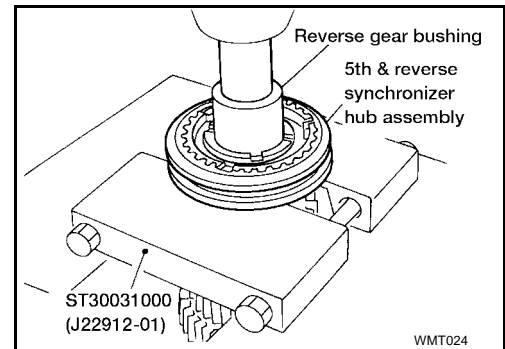

8. Remove 5th main gear, 5th gear baulk ring, and 5th gear needle bearing.
9. Place bearing replacer between 3rd and 4th main gears, and press out both 5th gear bushing and 4th main gear using Tool.

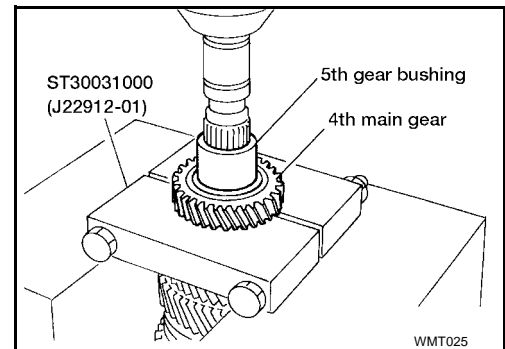

10. Remove mainshaft adjusting shim and spacer.

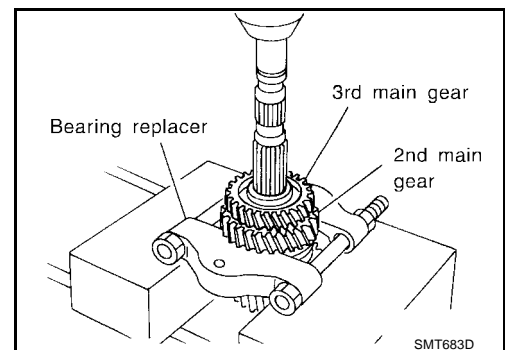

11. Place bearing replacer between 2nd main gear and 1st & 2nd synchronizer hub, and press out both 3rd and 2nd main gears.
12. Remove 2nd double cone assembly, 2nd gear bushing, and coupling sleeve assembly.

13. Place bearing replacer on 1st gear front side, and press out all of 2nd gear bushing, 1st & 2nd synchronizer hub, 1st main gear, and 1st double cone using Tool.

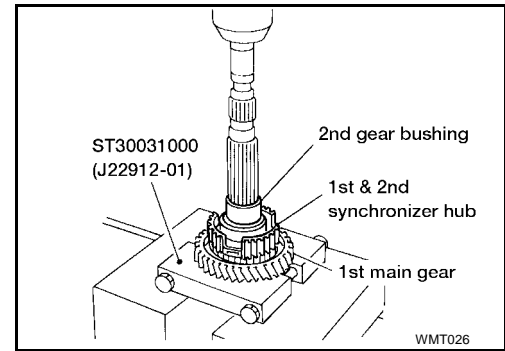

14. Remove 1st gear needle bearing.

Inspection GEAR AND SHAFT

ECS005TU

- Check shaft for cracks, wear or bending.
- Check gears for excessive wear, chips or cracks.

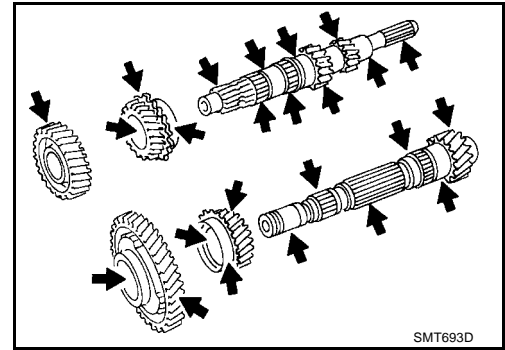

SYNCHRONIZERS

- Check spline area of coupling sleeves, hubs and gears for wear or cracks.
- Check baulk rings for cracks or deformation.
- Check insert springs for wear or deformation.

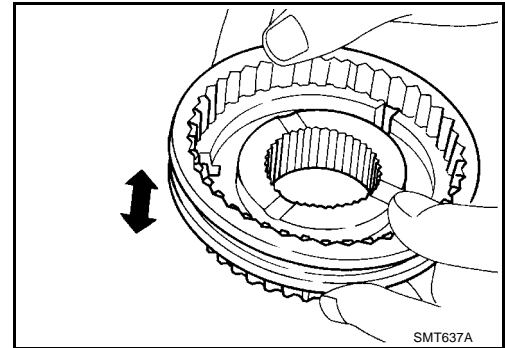

- If any crack, damage, or excessive wear is found on cam face of baulk ring or working face of insert, replace it.

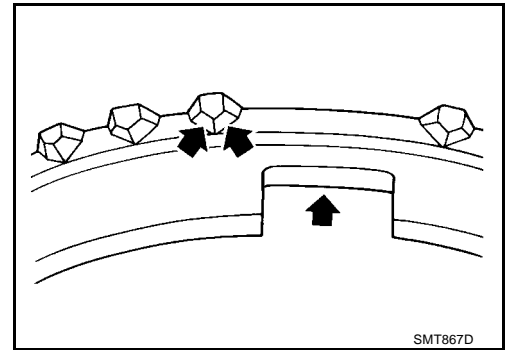

MAINSHAFT AND GEARS

[RS5F70A]

- Measure the movement (play, dimension "L") of 1st & 2nd coupling sleeve and 5th & reverse coupling sleeve with their end fixed and the other end lifted as shown in the figure. If the movement exceeds specification, replace the sleeve.

Coupling sleeve	Length "L"
1st & 2nd	0 - 0.68 mm (0 - 0.0268 in)
5th & Reverse	0 - 0.89 mm (0 - 0.0350 in)

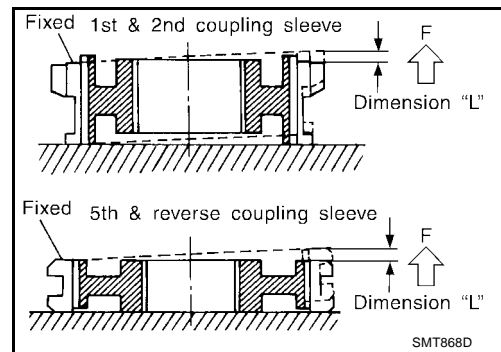

- Measure clearance between baulk ring and gear. Refer to [MT-64, "Clearance Between Baulk Ring and Gear"](#).

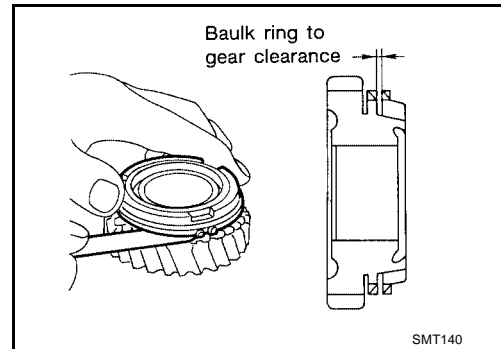

BEARING

- Make sure bearings roll freely and are free from noise, cracks, pitting or wear.

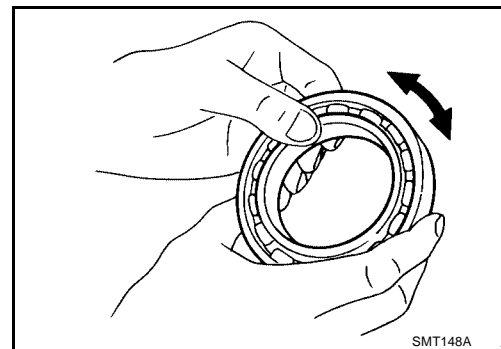

- Measure wear of inner and outer baulk ring as shown.

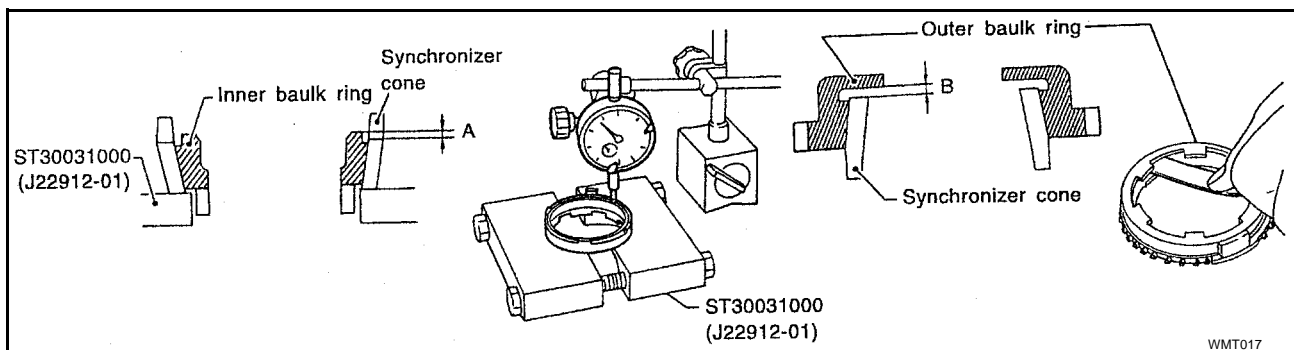

- Place baulk rings in position on synchronizer cone.
- While holding baulk ring against synchronizer cone as far as it will go, measure dimensions "A" and "B" using Tool.

Standard "A": 0.6 - 0.8 mm (0.024 - 0.031 in)

"B": 0.6 - 1.1 mm (0.024 - 0.043 in)

Wear limit : 0.2 mm (0.008 in)

- If dimension "A" or "B" is smaller than the wear limit, replace outer baulk ring, inner baulk ring and synchronizer cone as a set.

Assembly

1. Install 1st gear needle bearing and 1st main gear onto mainshaft.

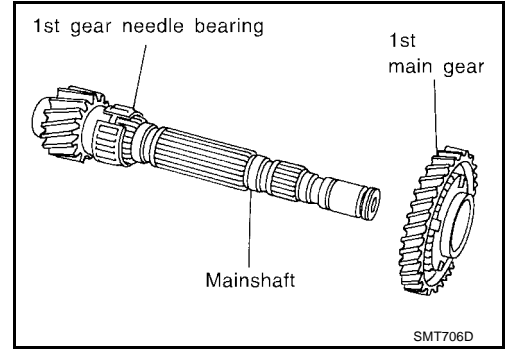

2. Install 1st double cone assembly onto mainshaft.
3. Install 1st & 2nd synchronizer hub with its three grooves facing the front side (1st main gear side) onto mainshaft.

CAUTION:

Do not reuse 1st & 2nd synchronizer hub.

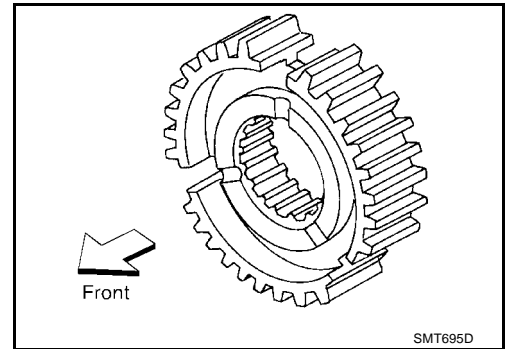

4. Install 1st & 2nd synchronizer hub using Tool.

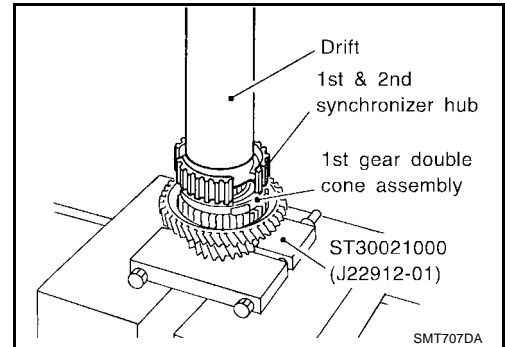

5. Install insert spring onto 1st & 2nd coupling sleeve.

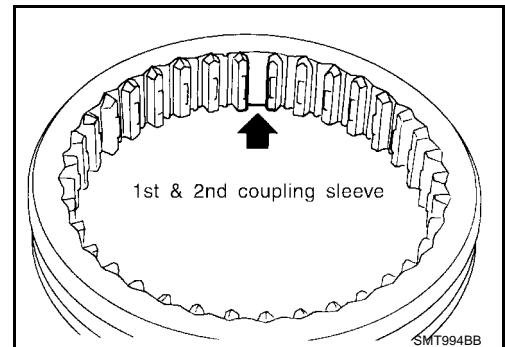

MAINSHAFT AND GEARS

[RS5F70A]

6. Install 1st & 2nd coupling sleeve with its chamfered surface facing the 1st main gear side onto 1st & 2nd synchronizer hub.

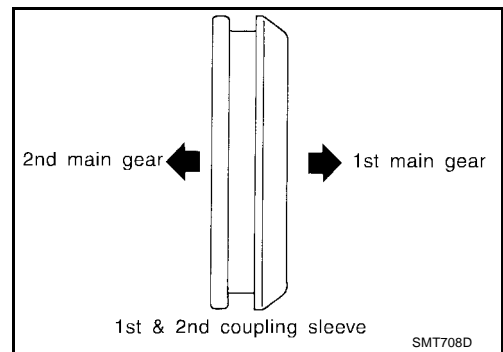

7. Install 2nd gear bushing with its flange surface facing 1st & 2nd synchronizer hub side using Tool.

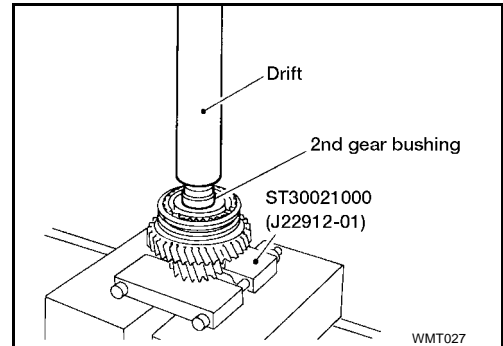

8. Install 2nd needle bearing, 2nd double cone assembly, and 2nd main gear onto mainshaft using Tool.

9. Position 3rd main gear as shown, and install it using Tool.

CAUTION:

Do not reuse 3rd main gear.

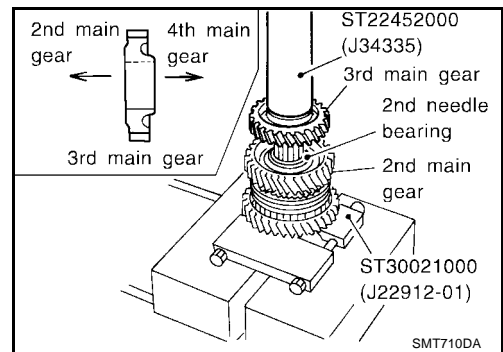

10. Install spacer and mainshaft adjusting shim onto mainshaft.

11. Select a mainshaft adjusting shim suitable to satisfy the following specification of dimension "L" and install it onto mainshaft.

Specification of dimension "L" : 151.35 - 151.45 mm (5.9586 - 5.9626 in)

Mainshaft adjusting shims : Refer to [MT-65, "Available Adjusting Shims"](#) .

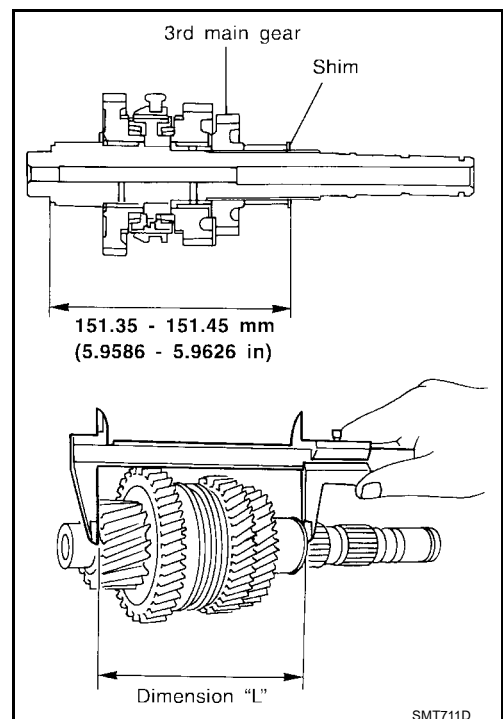

MAINSHAFT AND GEARS

[RS5F70A]

12. Position 4th main gear as shown, and install it onto mainshaft.

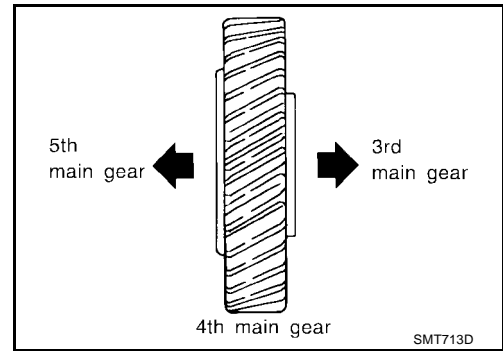

13. Install 4th main gear onto mainshaft using Tool.

CAUTION:
Do not reuse 4th main gear.

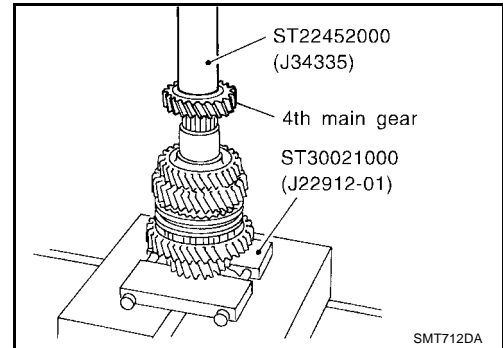

14. Install 5th gear bushing with its flange surface facing the 4th main gear side using Tool.

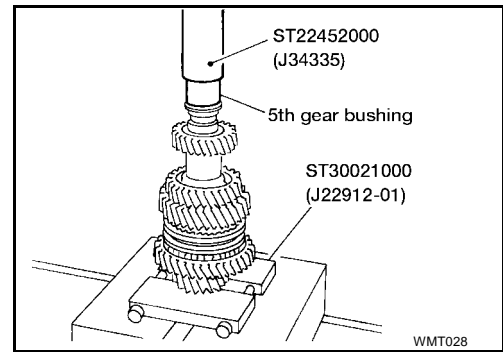

15. Install 5th needle bearing, 5th main gear, and 5th gear baulk ring onto mainshaft.

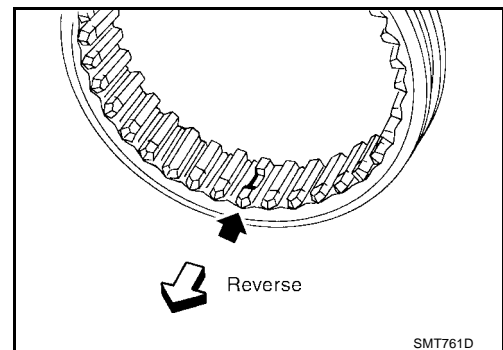

16. Being careful of the following points, install spread spring, shifting insert, and 5th & reverse synchronizer hub onto 5th & reverse coupling sleeve.

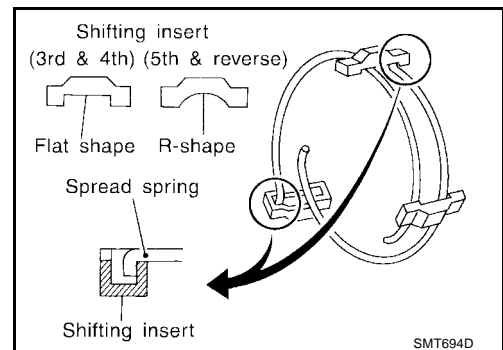

- Pay attention to the shape of spread spring and shifting insert for correct assembly.
Do not install spread spring hook onto the same shifting insert.
- Install synchronizer hub with its three grooves facing the front side (5th main gear side).

CAUTION:

Do not reuse 5th & reverse synchronizer hub.

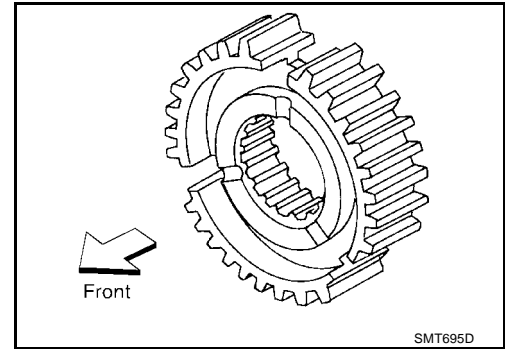

- Install 5th & reverse coupling sleeve with its chamfered surface facing the reverse main gear side.

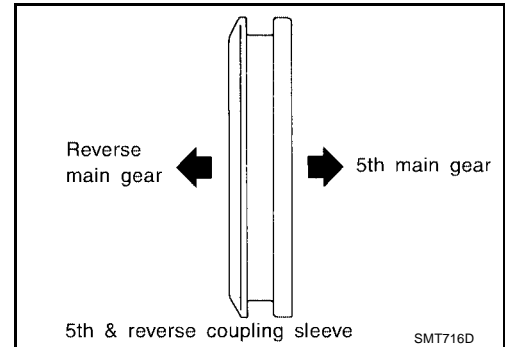

17. Install 5th & reverse synchronizer hub assembly using Tool.

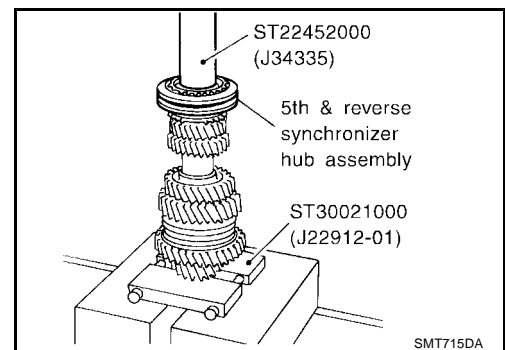

18. Install reverse gear baulk ring using Tool.

19. Install reverse gear bushing using Tool.

20. Install reverse gear needle bearing using Tool.

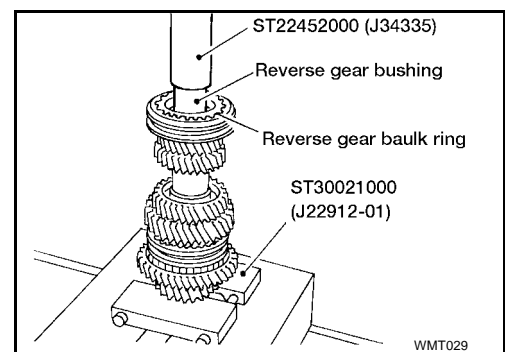

21. Install sub-gear, sub-gear washer, and snap ring onto reverse main gear.

CAUTION:

- Pay attention to direction of sub-gear washer.
- Do not reuse snap ring.

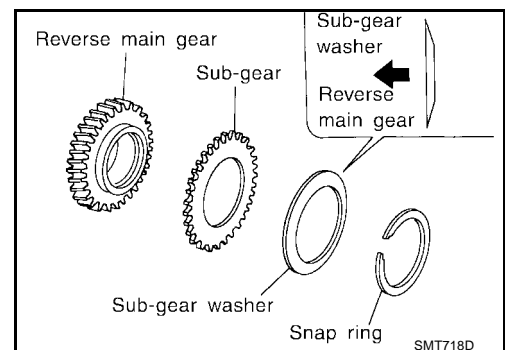

22. Install reverse main gear assembly onto mainshaft.
23. Select a thrust washer suitable to satisfy the following specification of dimension "M" as shown, and install it onto mainshaft.

Specification of dimension "M" : 244.20 - 244.30 mm (9.6142 - 9.6181 in)
Available thrust washers : Refer to [MT-67. "Available Thrust Washer"](#) .

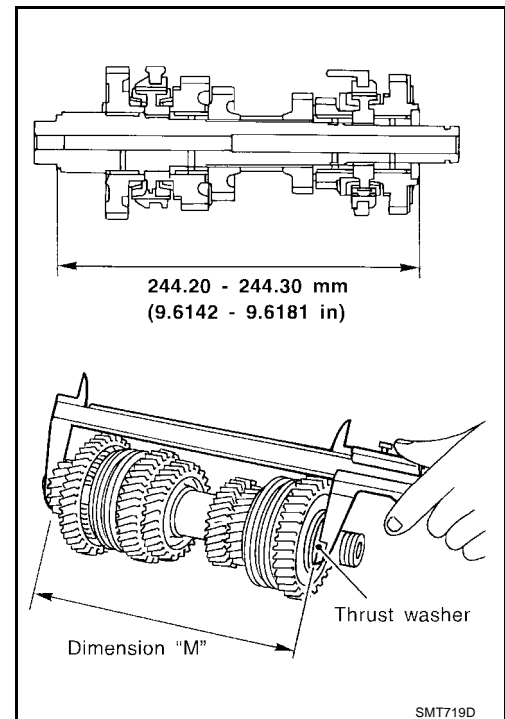

24. Install mainshaft rear bearing using Tool.

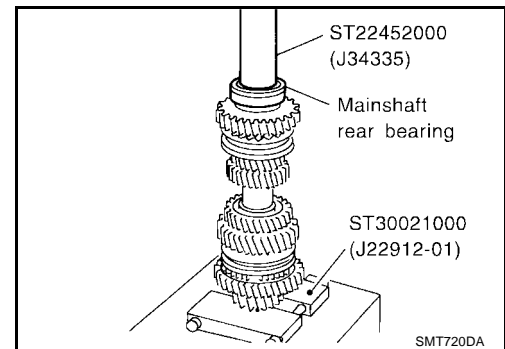

25. Install mainshaft C-ring.
26. Using feeler gauge, measure the end play of mainshaft rear bearing with a suitable tool, and check if it satisfies the following specification.

End play : 0 - 0.06 mm (0 - 0.0024 in)
Mainshaft C-rings : Refer to [MT-64. "Available C-rings"](#) .

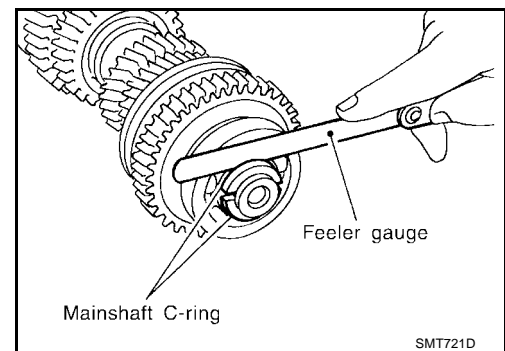

27. Install C-ring holder.

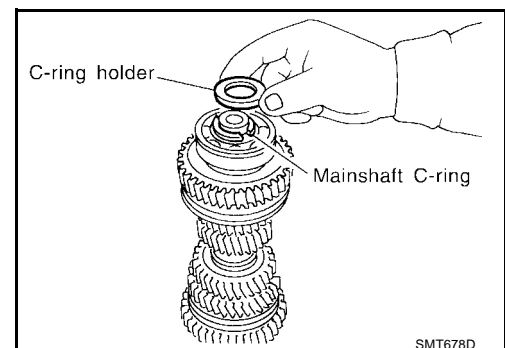

MAINSHAFT AND GEARS

[RS5F70A]

28. Install snap ring with a suitable tool.

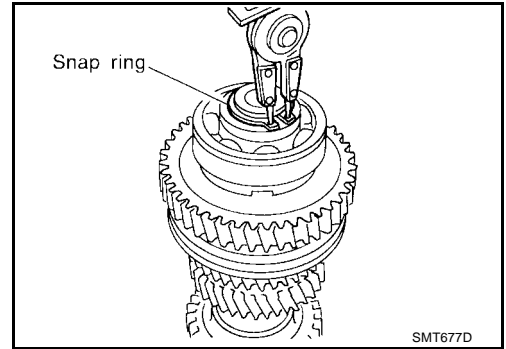

29. Measure gear end play as a final check. Refer to [MT-64, "Gear End Play"](#) .

A
B
MT
D
E
F
G
H
I
J
K
L
M

FINAL DRIVE

PF3:38411

Pre-inspection DIFFERENTIAL CASE SIDE

ECS005TW

1. Clean final drive assembly sufficiently to prevent side gear thrust washer, differential case, side gear, and other parts from sticking by gear oil.
2. Upright the differential case so that the side gear to be measured faces upward.
3. Place final drive adapter and dial gauge onto side gear. Move side gear up and down, and measure the clearance using Tool.

Clearance between side gear and differential case : 0.1 - 0.2 mm (0.004 - 0.008 in)

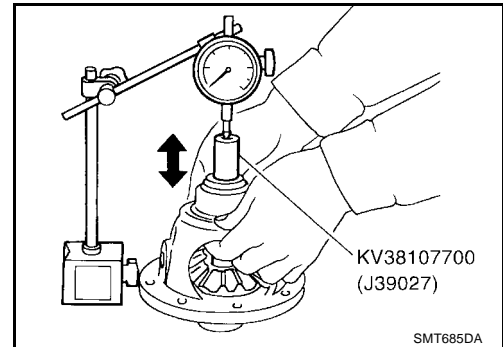

4. If not within specification, adjust the clearance by changing thrust washer thickness.
5. Turn differential case upside down, and measure the clearance between side gear and differential case on the other side in the same way using Tool.

Disassembly

ECS005TX

1. Remove the final gear bolts. Then, separate the final gear from differential case.
2. Make a notch and remove speedometer drive gear using a scraper or other suitable tool.
 - **Bearing replacer cannot be positioned unless speedometer drive gear is removed.**

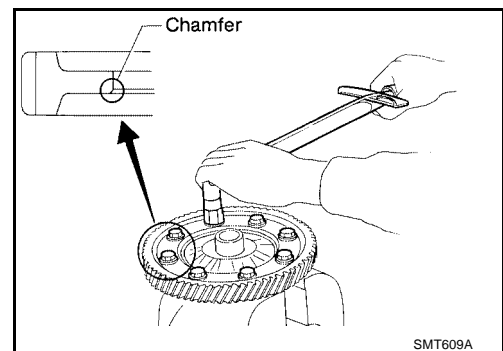

3. Remove differential side bearing of final gear side using Tool.
4. Turn differential case upside down, and remove differential side bearing of speedometer drive gear side using Tool.
 - **Be careful not to mix up the differential side bearings.**

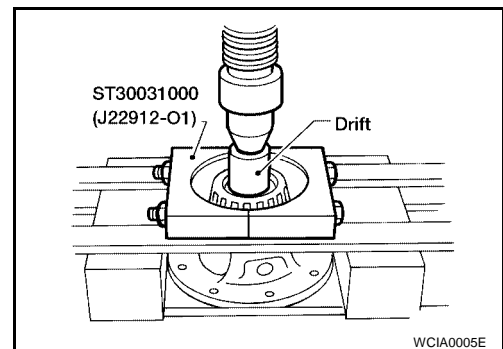

5. Remove speedometer stopper.
6. Remove lock pins from pinion mate shaft using Tool.

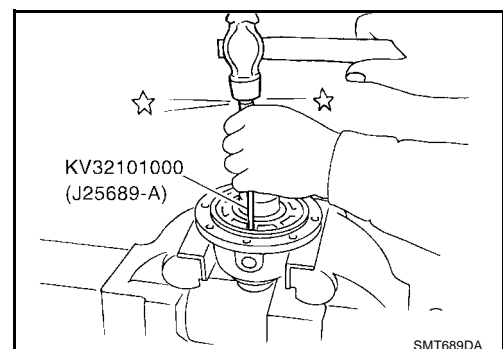

7. Remove pinion mate shaft.
8. Rotate pinion mate gear, and remove pinion mate gear, pinion mate thrust washer, side gear, and side gear thrust washer from differential case.

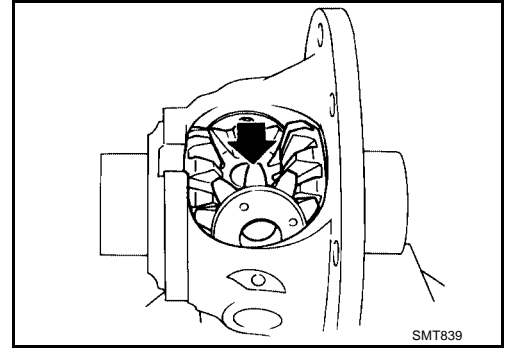

ECS005TY

Inspection GEAR, WASHER, SHAFT AND CASE

- Check mating surfaces of differential case, side gears and pinion mate gears.
- Check washers for wear.

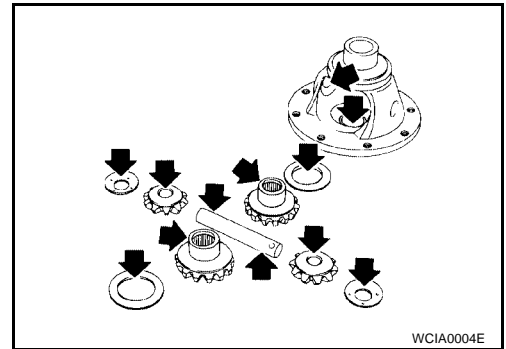

BEARING

- Make sure bearings roll freely and are free from noise, cracks, pitting or wear.

CAUTION:

When replacing tapered roller bearing, replace outer and inner race as a set.

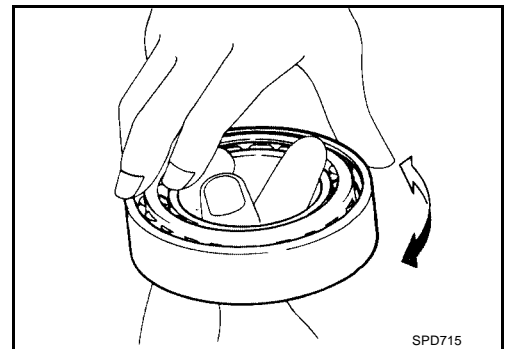

ECS005TZ

Assembly

1. Apply gear oil to sliding area of differential case, each gear, and thrust washer.
2. Install side gear thrust washer and side gear into differential case.
3. Position pinion mate gear and pinion mate thrust washer diagonally, and install them into differential case while rotating.

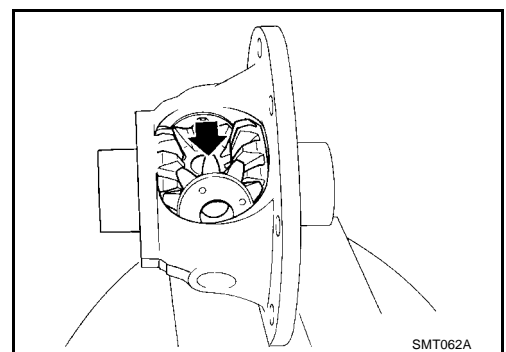

4. Insert pinion mate shaft into differential case.

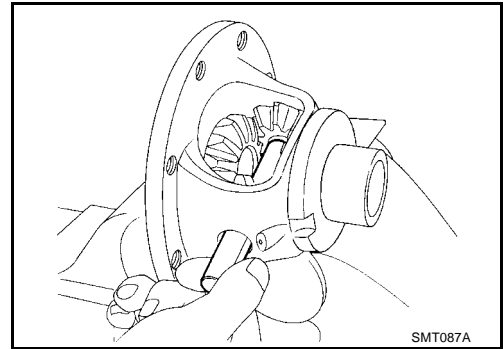

5. Upright the differential case so that its side gear to be measured faces upward.
6. Place preload adapter and dial gauge onto side gear. Move side gear up and down, and measure the clearance using Tool.
7. Turn differential case upside down, and measure the clearance between side gear and differential case on the other side in the same way using Tool.

Clearance of side gear and differential case : 0.1 - 0.2 mm (0.004 - 0.008 in)

Differential side gear thrust washers : Refer to [MT-67, "Available Washers"](#) .

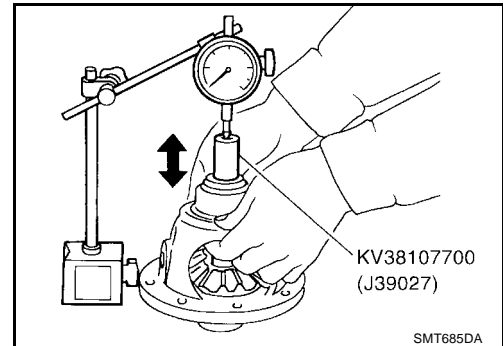

8. Install retaining pin using Tool.

- **Make sure that retaining pin is flush with case.**

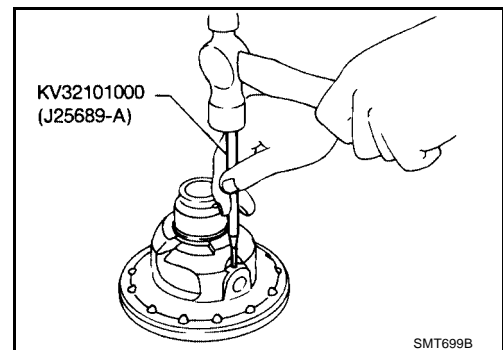

9. Align and install speedometer drive gear into differential case.
10. Install speedometer stopper.

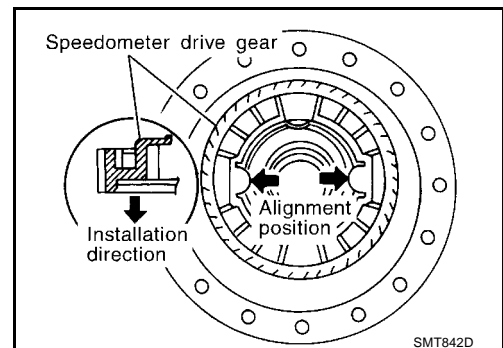

FINAL DRIVE

[RS5F70A]

11. Install differential side bearing using Tool.
12. Turn differential case upside down, and install another differential side bearing on the other side in the same way using Tool.

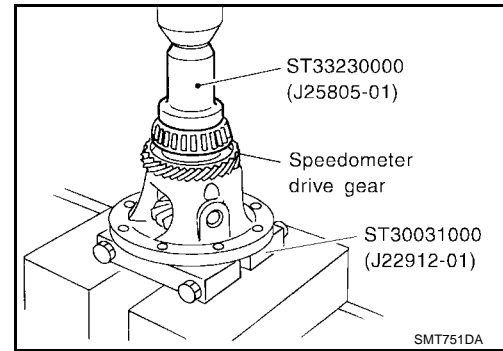

13. Install the final gear into the differential case. Apply sealant onto the final gear bolts, and tighten them in the order as shown to the specified torque.

Final gear bolts : Refer to [MT-23, "FINAL DRIVE COMPONENTS"](#) .

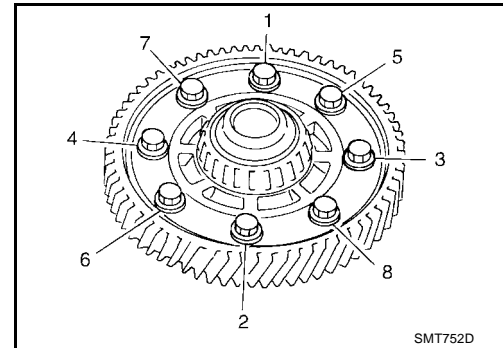

A
B
MT
D
E
F
G
H
I
J
K
L
M

SHIFT CONTROL

Inspection

- Check if the width of shift fork hook (sliding area with coupling sleeve) is within allowable specification below.

Item	One-side wear specification	Sliding width of new part
1st & 2nd	0.2 mm (0.008 in)	7.80 - 7.93 mm (0.3071 - 0.3122 in)
3rd & 4th	0.2 mm (0.008 in)	7.80 - 7.93 mm (0.3071 - 0.3122 in)
5th & reverse	0.2 mm (0.008 in)	7.80 - 7.93 mm (0.3071 - 0.3122 in)

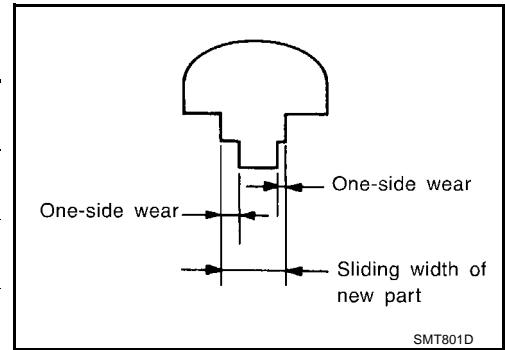

- Check if shift check groove of fork rod or 5th & reverse check groove is worn, or has any other abnormalities.

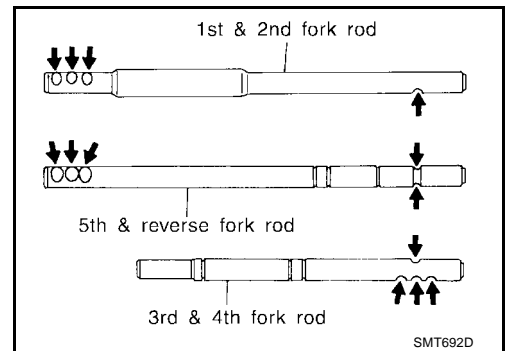

SERVICE DATA AND SPECIFICATIONS (SDS)

[RS5F70A]

SERVICE DATA AND SPECIFICATIONS (SDS)

PFP:00030

General Specifications TRANSAXLE

ECS005U1

Engine		QG18DE	
Transaxle model		RS5F70A	
Number of speeds		5	
Synchromesh type		Warner	
Shift pattern			
Gear ratio	1st	3.333	
	2nd	1.955	
	3rd	1.286	
	4th	0.926	
	5th	0.756	
	Reverse	3.214	
Number of teeth	Input gear	1st	15
		2nd	22
		3rd	28
		4th	41
		5th	45
		Rev.	14
	Main gear	1st	50
		2nd	43
		3rd	36
		4th	38
		5th	34
		Rev.	45
Reverse idler gear		37	
Oil level (Reference)	mm (in)*1	75.5 - 80.5 (2.972 - 3.169)	
Oil capacity	ℓ (qt)	3.0 (3 1/8)	
Remarks		1st & 2nd double baulk ring type synchronizer	
		Reverse sub-gear	

*1: Refer to [MA-13, "Fluids and Lubricants"](#) .

FINAL GEAR

Engine		QG18DE
Transaxle model		RS5F70A
Final gear ratio		4.176
Number of teeth	Final gear/Pinion	71/17
	Side gear/Pinion mate gear	16/10

SERVICE DATA AND SPECIFICATIONS (SDS)

[RS5F70A]

Gear End Play

ECS005U2

Unit: mm (in)

Gear	End play
1st main gear	0.18 - 0.31 (0.0071 - 0.0122)
2nd main gear	
5th main gear	
Reverse main gear	
3rd input gear	
4th input gear	0.17 - 0.44 (0.0067 - 0.0173)

Clearance Between Baulk Ring and Gear 3RD, 4TH, 5TH, REVERSE BAULK RING

ECS005U3

Unit: mm (in)

Standard		Wear limit
3rd	0.90 - 1.45 (0.0354 - 0.0571)	0.7 (0.028)
4th		
5th		
Reverse	0.9 - 1.35 (0.0354 - 0.0531)	

1ST AND 2ND BAULK RING

Unit: mm (in)

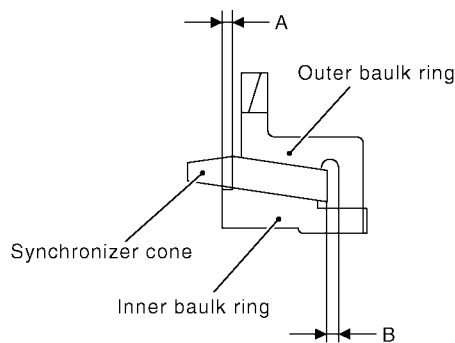

SMT906D

Dimension	Standard	Wear limit
A	0.6 - 0.8 (0.024 - 0.031)	0.2 (0.008)
B	0.6 - 1.1 (0.024 - 0.043)	

Available Snap Rings SNAP RING

ECS005U4

End play	0.05 - 0.25 mm (0.0020 - 0.0098 in)
Thickness	Part number*
1.45 mm (0.0571 in)	32204-6J000
1.55 mm (0.0610 in)	32204-6J001
1.65 mm (0.0650 in)	32204-6J002
1.75 mm (0.0689 in)	32204-6J003
1.85 mm (0.0728 in)	32204-6J004

*: Always check with the parts department for the latest information.

Available C-rings 4TH INPUT GEAR C-RING

ECS005U5

End play	0 - 0.06 mm (0 - 0.0024 in)
Thickness	Part number*

SERVICE DATA AND SPECIFICATIONS (SDS)

[RS5F70A]

3.00 mm (0.1181 in)	32205-6J000
3.03 mm (0.1193 in)	32205-6J001
3.06 mm (0.1205 in)	32205-6J002
3.09 mm (0.1217 in)	32205-6J003
3.12 mm (0.1228 in)	32205-6J004

*: Always check with the parts department for the latest information.

5TH INPUT GEAR REAR C-RING

End play	0 - 0.06 mm (0 - 0.0024 in)
Thickness	Part number*
2.59 mm (0.1020 in)	32205-6J005
2.62 mm (0.1031 in)	32205-6J006
2.65 mm (0.1043 in)	32205-6J007
2.68 mm (0.1055 in)	32205-6J008
2.71 mm (0.1067 in)	32205-6J009
2.74 mm (0.1079 in)	32205-6J010

*: Always check with the parts department for the latest information.

MAINSHAFT C-RING

End play	0 - 0.06 mm (0 - 0.0024 in)
Thickness	Part number*
3.48 mm (0.1370 in)	32348-6J000
3.51 mm (0.1382 in)	32348-6J001
3.54 mm (0.1394 in)	32348-6J002
3.57 mm (0.1406 in)	32348-6J003
3.60 mm (0.1417 in)	32348-6J004
3.63 mm (0.1429 in)	32348-6J005
3.66 mm (0.1441 in)	32348-6J006
3.69 mm (0.1453 in)	32348-6J007
3.72 mm (0.1465 in)	32348-6J008
3.75 mm (0.1476 in)	32348-6J009
3.78 mm (0.1488 in)	32348-6J010
3.81 mm (0.1500 in)	32348-6J011
3.84 mm (0.1512 in)	32348-6J012
3.87 mm (0.1524 in)	32348-6J013
3.90 mm (0.1535 in)	32348-6J014
3.93 mm (0.1547 in)	32348-6J015
3.96 mm (0.1559 in)	32348-6J016

*: Always check with the parts department for the latest information.

Available Adjusting Shims INPUT SHAFT REAR BEARING ADJUSTING SHIM

ECS005U6

End play	0 - 0.06 mm (0 - 0.0024 in)
Thickness	Part number*
0.74 mm (0.0291 in)	32225-6J003
0.78 mm (0.0307 in)	32225-6J004
0.82 mm (0.0323 in)	32225-6J005
0.86 mm (0.0339 in)	32225-6J006

SERVICE DATA AND SPECIFICATIONS (SDS)

[RS5F70A]

0.90 mm (0.0354 in)	32225-6J007
0.94 mm (0.0370 in)	32225-6J008
0.98 mm (0.0386 in)	32225-6J009
1.02 mm (0.0402 in)	32225-6J010
1.06 mm (0.0417 in)	32225-6J011
1.10 mm (0.0433 in)	32225-6J012
1.14 mm (0.0449 in)	32225-6J013
1.18 mm (0.0465 in)	32225-6J014
1.22 mm (0.0480 in)	32225-6J015
1.26 mm (0.0496 in)	32225-6J016
1.30 mm (0.0512 in)	32225-6J017
1.34 mm (0.0528 in)	32225-6J018
1.38 mm (0.0543 in)	32225-6J019
1.42 mm (0.0559 in)	32225-6J020
1.46 mm (0.0575 in)	32225-6J021
1.50 mm (0.0591 in)	32225-6J022
1.54 mm (0.0606 in)	32225-6J023
1.58 mm (0.0622 in)	32225-6J024
1.62 mm (0.0638 in)	32225-6J060
1.66 mm (0.0654 in)	32225-6J061

*: Always check with the parts department for the latest information.

MAINSHAFT ADJUSTING SHIM

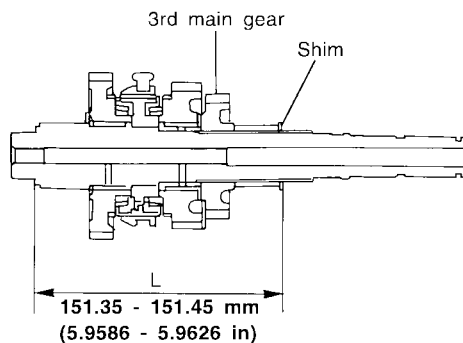

SMT907D

Standard length "L"	151.35 - 151.45 mm (5.9586 - 5.9626 in)
Thickness	Part number*
0.48 mm (0.0189 in)	32238-6J000
0.56 mm (0.0220 in)	32238-6J001
0.64 mm (0.0252 in)	32238-6J002
0.72 mm (0.0283 in)	32238-6J003
0.80 mm (0.0315 in)	32238-6J004
0.88 mm (0.0346 in)	32238-6J005

*: Always check with the parts department for the latest information.

MAINSHAFT REAR BEARING ADJUSTING SHIM

End play	0 - 0.06 mm (0 - 0.0024 in)
Thickness	Part number*
2.99 mm (0.1177 in)	32238-6J010
3.03 mm (0.1193 in)	32238-6J011

SERVICE DATA AND SPECIFICATIONS (SDS)

[RS5F70A]

3.07 mm (0.1209 in)	32238-6J012
3.11 mm (0.1224 in)	32238-6J013
3.15 mm (0.1240 in)	32238-6J014
3.19 mm (0.1256 in)	32238-6J015
3.23 mm (0.1272 in)	32238-6J016
3.27 mm (0.1287 in)	32238-6J017
3.31 mm (0.1303 in)	32238-6J018
3.35 mm (0.1319 in)	32238-6J019
3.39 mm (0.1335 in)	32238-6J020
3.43 mm (0.1350 in)	32238-6J021
3.47 mm (0.1366 in)	32238-6J022
3.51 mm (0.1382 in)	32238-6J023

*: Always check with the parts department for the latest information.

Available Thrust Washer MAINSHAFT THRUST WASHER

ECS005U7

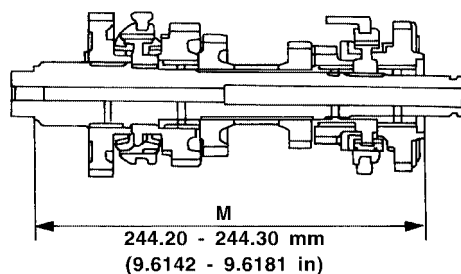

SMT843D

Standard length "M"	244.20 - 244.30 mm (9.6142 - 9.6181 in)
Thickness	Part number*
6.04 mm (0.2378 in)	32246-6J000
6.12 mm (0.2409 in)	32246-6J001
6.20 mm (0.2441 in)	32246-6J002
6.28 mm (0.2472 in)	32246-6J003
6.36 mm (0.2504 in)	32246-6J004

*: Always check with the parts department for the latest information.

Available Washers DIFFERENTIAL SIDE GEAR THRUST WASHER

ECS005U8

Clearance between side gear and differential case	0.1 - 0.2 mm (0.004 - 0.008 in)
Thickness mm (in)	Part number*
0.75 - 0.80 (0.0295 - 0.0315)	38424-D2111
0.80 - 0.85 (0.0315 - 0.0335)	38424-D2112
0.85 - 0.90 (0.0335 - 0.0354)	38424-D2113
0.90 - 0.95 (0.0354 - 0.0374)	38424-D2114
0.95 - 1.00 (0.0374 - 0.0394)	38424-D2115

*: Always check with the parts department for the latest information.

SERVICE DATA AND SPECIFICATIONS (SDS)

[RS5F70A]

Available Shims — Differential Side Bearing Preload and Adjusting Shim BEARING PRELOAD

ECS005U9

Unit: mm (in)

Differential side bearing preload: T*	0.15 - 0.21 (0.0059 - 0.0083)
---------------------------------------	-------------------------------

* Install shims which are "deflection of differential case" + "T" in thickness.

DIFFERENTIAL SIDE BEARING ADJUSTING SHIMS

Thickness mm (in)	Part number*
0.44 (0.0173)	38454-M8000
0.48 (0.0189)	38454-M8001
0.52 (0.0205)	38454-M8002
0.56 (0.0220)	38454-M8003
0.60 (0.0236)	38454-M8004
0.64 (0.0252)	38454-M8005
0.68 (0.0268)	38454-M8006
0.72 (0.0283)	38454-M8007
0.76 (0.0299)	38454-M8008
0.80 (0.0315)	38454-M8009
0.84 (0.0331)	38454-M8010
0.88 (0.0346)	38454-M8011

*: Always check with the parts department for the latest information.

PRECAUTIONS

[RS5F51A]

PRECAUTIONS

PFP:00001

Cautions

ECS005UA

- Do not reuse transaxle oil, once it has been drained.
- Check oil level or replace oil with vehicle on level ground.
- During removal or installation, keep inside of transaxle clear of dust or dirt.
- Check for the correct installation status prior to removal or disassembly. If mating marks are required, be certain they do not interfere with the function of the parts they are applied to.
- In principle, tighten bolts or nuts gradually in several steps working diagonally from inside to outside. If tightening sequence is specified, observe it.
- Be careful not to damage sliding surfaces and mating surfaces.

A

B

MT

D

E

F

G

H

I

J

K

L

M

PREPARATION

[RS5F51A]

PFP:00002

ECS005UB

PREPARATION

Special Service Tools

The actual shapes of the Kent-Moore tools may differ from those of the special tools illustrated here.

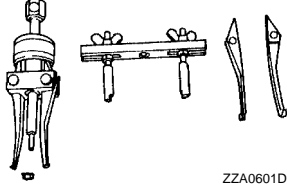
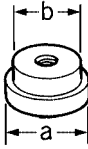
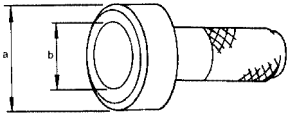
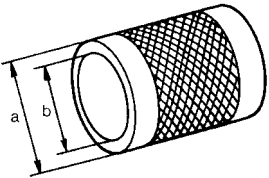
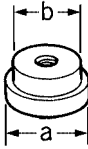
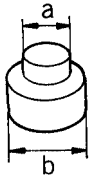
Tool number (Kent-Moore No.) Tool name		Description
KV381054S0 (J34286) Puller	 <p style="text-align: center;">ZZA0601D</p>	Side bearing outer race removal Main shaft front bearing removal
ST35321000 (—) Drift	 <p style="text-align: center;">ZZA1000D</p>	Input shaft oil seal installation Reverse main gear installation 1st bushing installation 1st-2nd synchronizer hub installation 2nd bushing installation 3rd main gear installation a: 49 mm (1.93 in) dia. b: 41 mm 1.61 in) dia.
ST30720000 (J25405) Drift	 <p style="text-align: center;">ZZA0811D</p>	Differential oil seal installation Differential side bearing outer race installation Mainshaft rear bearing installation Differential side bearing installation a: 77 mm (3.03 in) dia. b: 55.5 mm (2.185 in) dia.
ST33200000 (J26082) Drift	 <p style="text-align: center;">ZZA1002D</p>	Mainshaft front bearing installation 4th main gear installation 5th main gear installation a: 60 mm (2.36 in) dia. b: 44.5 mm (1.752 in) dia.
ST33061000 (J8107-2) Drift	 <p style="text-align: center;">ZZA1000D</p>	Bore plug installation Differential side bearing removal a: 38 mm (1.50 in) dia. b: 28.5 mm (1.122 in) dia.
ST33052000 (—) Drift	 <p style="text-align: center;">ZZA1023D</p>	Welch plug installation Input shaft rear bearing removal Input shaft bearing spacer and 5th stopper removal 5th bushing, thrust washer, 4th input gear, 4th gear bushing, 3rd-4th synchronizer hub and 3rd input gear removal Input shaft front bearing installation Mainshaft rear bearing removal 4th main gear and 5th main gear removal a: 22 mm (0.87 in) dia. b: 28 mm (1.10 in) dia.

PREPARATION

[RS5F51A]

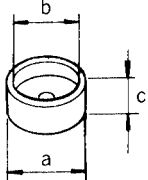
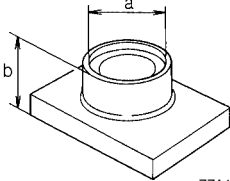
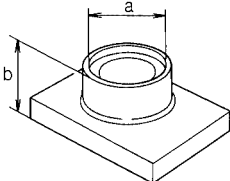
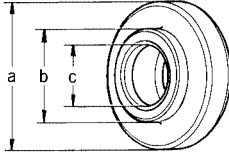
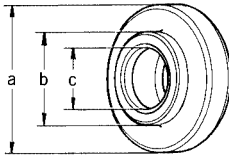
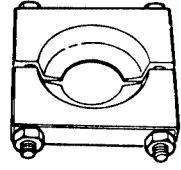
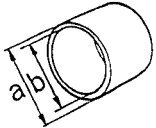
Tool number (Kent-Moore No.) Tool name	Description	
KV40105020 (—) Drift	 <p>5th input gear and synchronizer hub removal 3rd main gear, 2nd main gear, 2nd bushing, 1st-2nd synchronizer hub, 1st main gear, re- verse main gear and 1st bushing removal a: 39.7 mm (1.563 in) dia. b: 35 mm (1.38 in) dia. c: 15 mm (0.59 in).</p>	A B MT
KV40105710 (—) Press stand	 <p>3rd-4th synchronizer hub installation 4th bushing installation 5th bushing installation 5th synchronizer hub installation 2nd bushing installation 3rd main gear installation a: 46 mm (1.81 in) dia. b: 41 mm (1.61 in).</p>	D E F
ST38220000 (—) Press stand	 <p>Reverse main gear installation 1st bushing installation 1st-2nd synchronizer hub installation a: 63 mm (2.48 in) dia. b: 65 mm (2.56 in).</p>	G H
ST30032000 (J26010-01) Drift	 <p>5th stopper and input shaft bearing spacer in- stallation Input shaft front bearing installation a: 63 mm (2.48 in) dia. b: 38 mm (1.50 in) dia. c: 31 mm (1.22 in) dia.</p>	I J
ST30901000 (J26010-01) Drift	 <p>Input shaft rear bearing installation 4th main gear installation 5th main gear installation Mainshaft rear bearing installation a: 79 mm (3.11 in) dia. b: 45 mm (1.77 in) dia. c: 35.2 mm (1.386 in) dia.</p>	K L
ST30031000 (J22912-01) Puller	 <p>Measuring wear of 1st and 2nd baulk ring</p>	M
KV40101630 (J35870) Drift	 <p>Reverse main gear installation a: 68 mm (2.68 in) dia. b: 60 mm (2.36 in) dia.</p>	

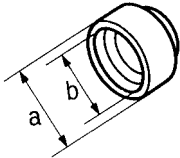
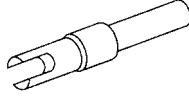

PREPARATION

[RS5F51A]

Tool number (Kent-Moore No.) Tool name	Description
KV38102510 (—) Drift	1st bushing installation 1st-2nd synchronizer hub installation Differential side bearing installation a: 71 mm (2.80 in) dia. b: 65 mm (2.56 in) dia.
 <p style="text-align: right; font-size: small;">ZZA0838D</p>	
(J39713) Preload adapter	Checking differential side gear end play
 <p style="text-align: right; font-size: small;">NT087</p>	

Commercial Service Tools

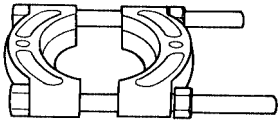
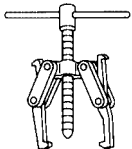
ECS005UC

Tool name	Description
Puller	Each bearing gear and bushing removal
 <p style="text-align: right; font-size: x-small;">ZZB0823D</p>	
Puller	Each bearing gear and bushing removal
 <p style="text-align: right; font-size: x-small;">NT077</p>	
Pin punch	Each retaining pin removal and installation Tip: 4.5 mm (0.177 in) dia.
 <p style="text-align: right; font-size: x-small;">ZZA0815D</p>	

NOISE, VIBRATION, AND HARSHNESS (NVH) TROUBLESHOOTING

[RS5F51A]

NOISE, VIBRATION, AND HARSHNESS (NVH) TROUBLESHOOTING

PF0:0003

NVH Troubleshooting Chart

ECS005UD

Use the chart below to help you find the cause of the symptom. The numbers indicate the order of the inspection. If necessary, repair or replace these parts.

Reference page		MT-76	MT-76	MT-76	MT-84			MT-79	MT-87		MT-85, MT-88			
Suspected parts (possible cause)		(oil level is low)	(wrong oil)	(oil level is high)	Gasket (damaged)	Oil seal (worn or damaged)	O-Ring (worn or damaged)	Control device and cable (worn)	Check plug return spring and check ball (worn or damaged)	Shift fork (worn)	Gear (worn or damaged)	Bearing (worn or damaged)	Baulk ring (worn or damaged)	Insert spring, shifting insert (damaged)
Symptom	Noise	1	2								3	3		
	Oil leakage		3	1	2	2	2							
	Hard to shift or will not shift		1	1				2					3	3
	Jumps out of gear							1	2	3	3			

A
B
MT
D
E
F
G
H
I
J
K
L
M

DESCRIPTION

Cross-sectional View

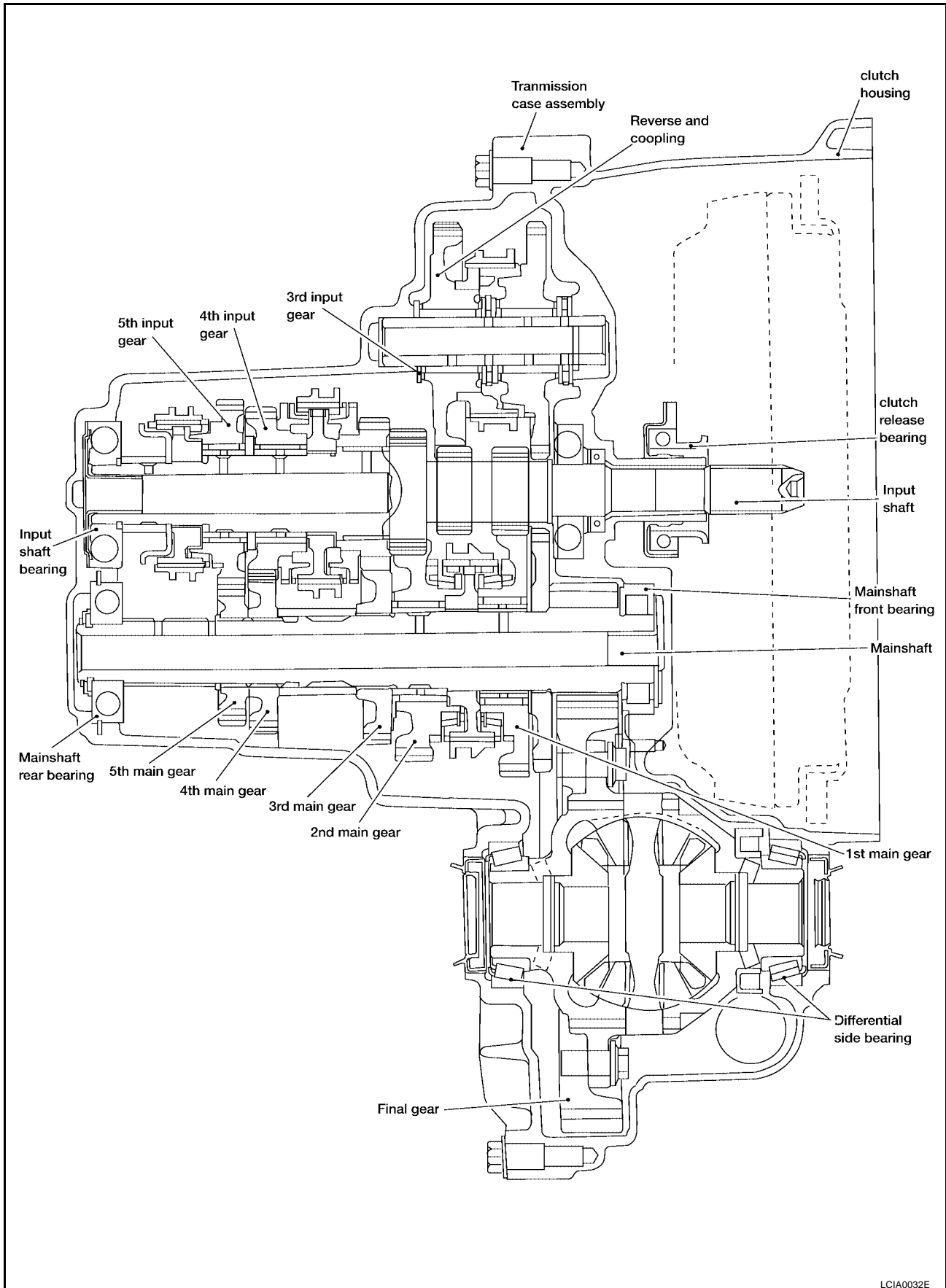

DESCRIPTION

[RS5F51A]

DOUBLE-CONE SYNCHRONIZER

Double-cone synchronizer is adopted for 1st and 2nd gears to reduce operating force of the shift lever.

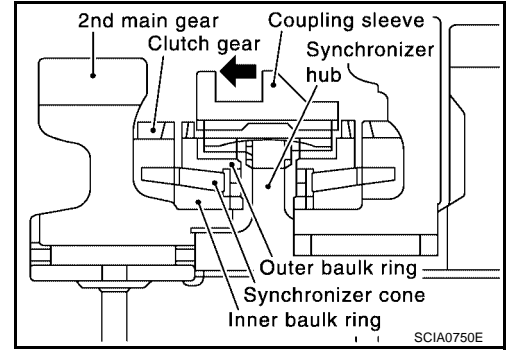

REVERSE GEAR

Description of reverse gear components are as shown.

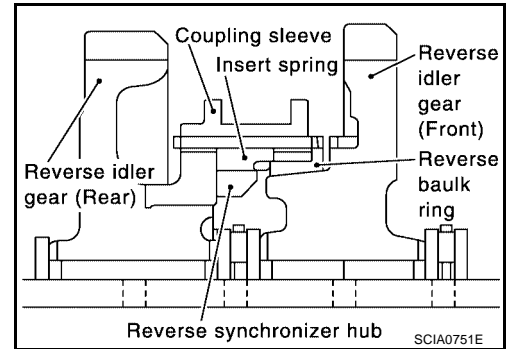

A
B
MT
D
E
F
G
H
I
J
K
L
M

M/T OIL**Replacement
DRAINING**

1. Start the engine and let it run to warm up the transaxle.
2. Stop the engine. Remove drain plug and drain oil.
3. Set a new gasket on the drain plug and install it on the transaxle.

Drain plug : 30 - 39 N·m (3.1 - 4.0 kg·m, 23 - 28 ft·lb)

CAUTION:

Do not reuse gasket.

FILLING

1. Remove filler plug. Fill with new oil until oil level reaches the specified limit near filler plug mounting hole.

Oil grade : API GL-4

Capacity (reference) : Approximately 2.3 ℓ (2 3/8 qt)

2. After refilling oil, check oil level. Assemble new gasket on to filler plug, then install it on the transaxle body.

Filler plug : 30 - 39 N·m (3.1 - 4.0 kg·m, 23 - 28 ft·lb)

CAUTION:

Do not reuse gasket.

**Checking
OIL LEAKAGE AND OIL LEVEL**

ECS005UG

- Check that oil is not leaking from transaxle.
- Check oil level from filler plug mounting hole as shown.

CAUTION:

Never start engine while checking oil level.

- Set a new gasket on the filler plug and install it on the transaxle.

Filler plug : 30 - 39 N·m (3.1 - 4.0 kg·m, 23 - 28 ft·lb)

CAUTION:

Do not reuse gasket.

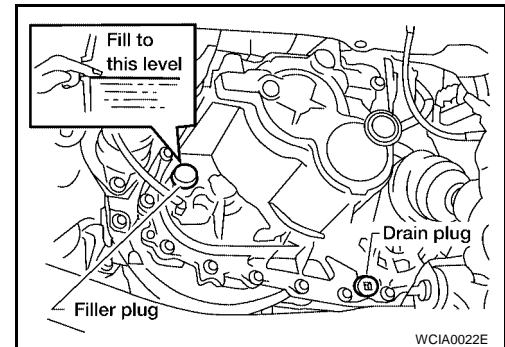

SIDE OIL SEAL

[RS5F51A]

PF3:32113

ECS005UH

SIDE OIL SEAL

Removal and Installation

REMOVAL

1. Remove the drive shaft from the transaxle body. Refer to [FAX-14, "Removal"](#).
2. Remove oil seal with a slotted screwdriver.

CAUTION:

Be careful not to damage the case surface when removing the oil seal.

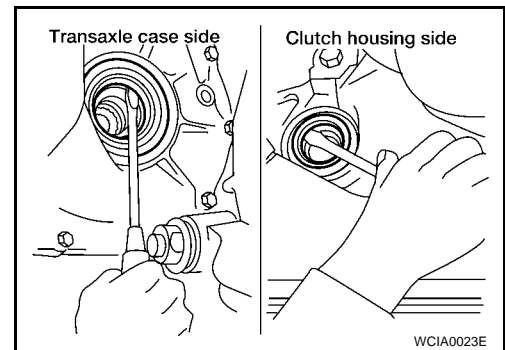

INSTALLATION

Installation is in the reverse order of removal.

- Using Tool (drift), drive the oil seal straight until it protrudes from the case end equal to dimension "A" as shown.

Dimension "A" : Within 0.5 mm (0.02 in) or flush with the case.

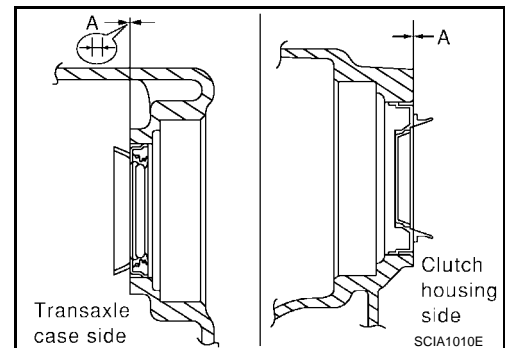

Special Service Tool

Drift to be used	ST30720000
------------------	------------

CAUTION:

- When installing oil seal, apply multi-purpose grease to oil seal lips.
 - Oil seal is not reusable.
- Check the oil level after installation. Refer to [MT-76, "Checking"](#).

POSITION SWITCH

Checking

NOTE:

For removal and installation of the switches. Refer to [MT-84, "Component Parts"](#) .

BACK-UP LAMP SWITCH

- Check continuity.

Gear position	Continuity
Reverse	Yes
Except reverse	No

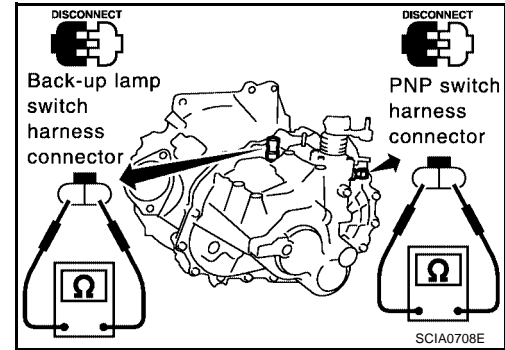

PARK/NEUTRAL POSITION SWITCH

- Check continuity.

Gear position	Continuity
Neutral	Yes
Except neutral	No

CONTROL LINKAGE

[RS5F51A]

PF3:34103

ECS005UJ

CONTROL LINKAGE

Removal and Installation of Control Device and Cable

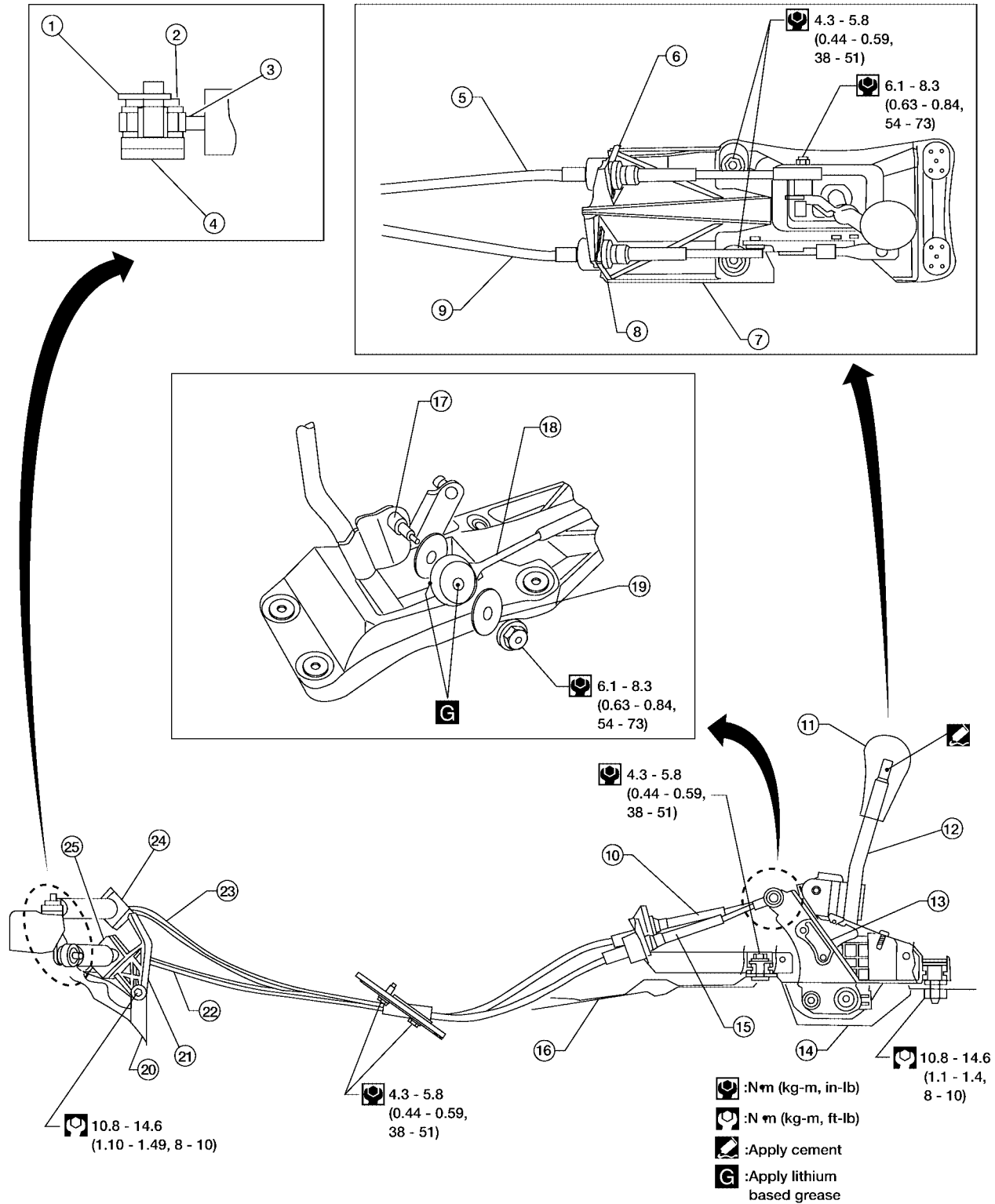

- 1. Snap pin
- 2. Washer
- 3. Cable
- 4. Manual lever
- 5. Shift cable
- 6. Lock plate
- 7. Control device assembly
- 8. Lock plate
- 9. Select cable
- 10. Shift cable
- 11. Control lever knob
- 12. Control lever

- 13. Control lever
- 14. Control lever
- 15. Control lever
- 16. Control lever
- 17. Control lever
- 18. Control lever
- 19. Control lever
- 20. Control lever
- 21. Control lever
- 22. Control lever
- 23. Control lever
- 24. Control lever
- 25. Control lever

- 26. Control lever
- 27. Control lever
- 28. Control lever
- 29. Control lever
- 30. Control lever
- 31. Control lever
- 32. Control lever
- 33. Control lever
- 34. Control lever
- 35. Control lever
- 36. Control lever
- 37. Control lever
- 38. Control lever
- 39. Control lever
- 40. Control lever

WCIA0136E

- | | | |
|-----------------------------|--------------------|----------------------------|
| 13. Control device assembly | 14. Cover | 15. Select cable |
| 16. Floor | 17. Pin | 18. Shift cable |
| 19. Washer | 20. Clutch housing | 21. Cable mounting bracket |
| 22. Select cable | 23. Shift cable | 24. Lock plate |
| 25. Lock plate | | |

CAUTION:

- Note that the select side lock plate for securing the control cable is different from the one on the shift side.
- After assembly, make sure selector lever automatically returns to Neutral when it is moved to 1st, 2nd, or Reverse.

Cable Adjustment

ECS0077V

NOTE:

After installation of the select cable, the cable must be adjusted for proper operation. This adjustment is performed before installing the interior console and shift boot.

1. Slide clip "B" from under clip "A" as shown.

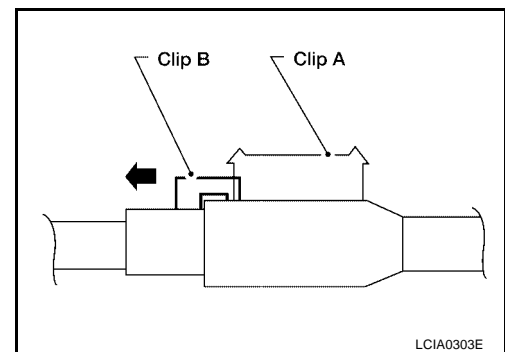

2. Shift the control lever to the neutral position.

CAUTION:

Do not move the control lever when adjusting the cables.

3. Push clip "A" into the cable end case until it snaps into place as shown.

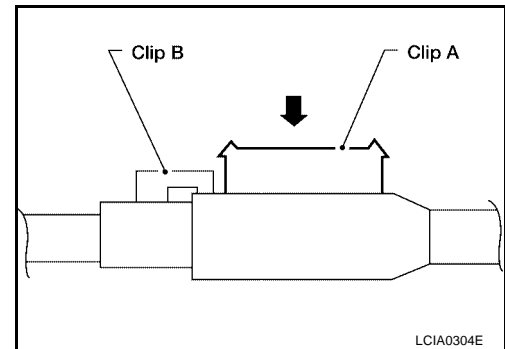

4. Slide clip "B" back over clip "A" until it snaps into place and holds clip "A" in place as shown.

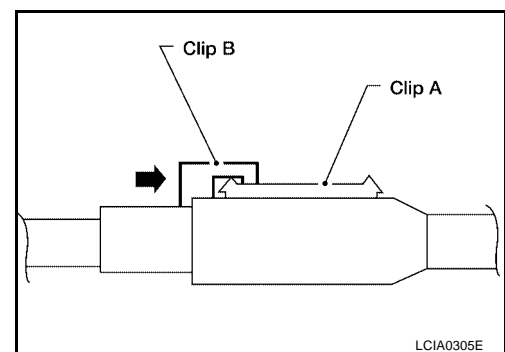

AIR BREATHER HOSE

Removal and Installation

Refer to the illustration for air breather hose removal and installation information.

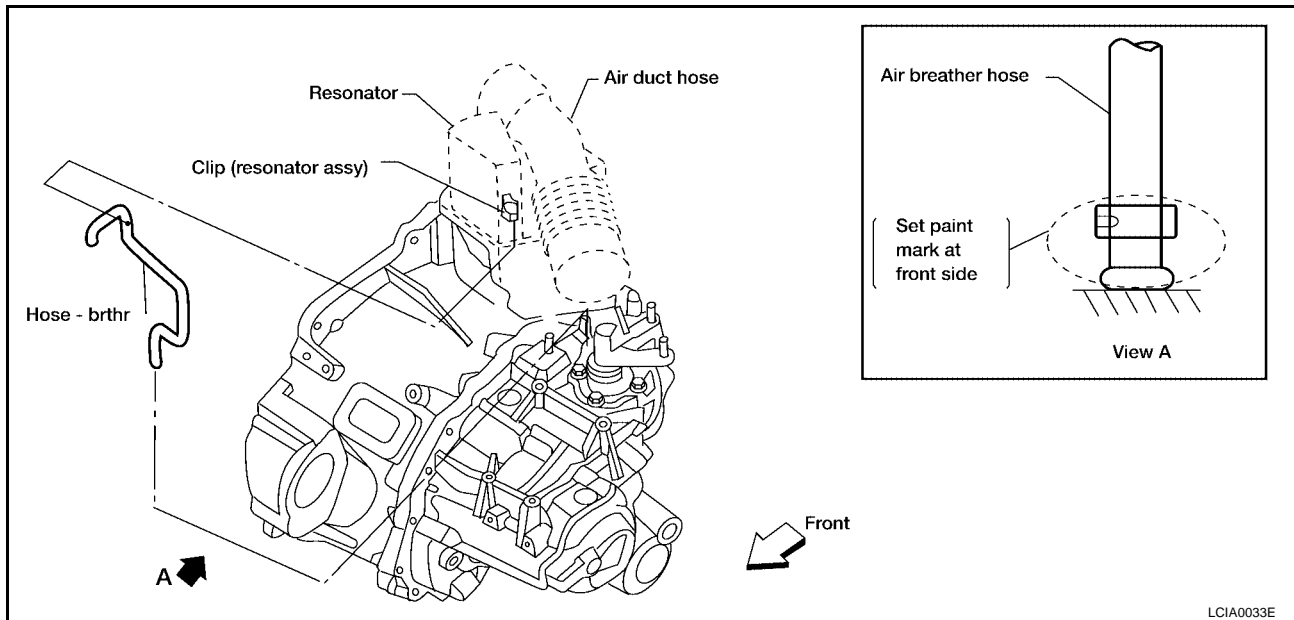

CAUTION:

- Make sure there are no pinched or restricted areas on the air breather hose caused by bending or winding when installing it.
- Be sure to insert hose into the transaxle tube until overlap area reaches the spool.

A
B
MT
D
E
F
G
H
I
J
K
L
M

TRANSAXLE ASSEMBLY

Removal and Installation

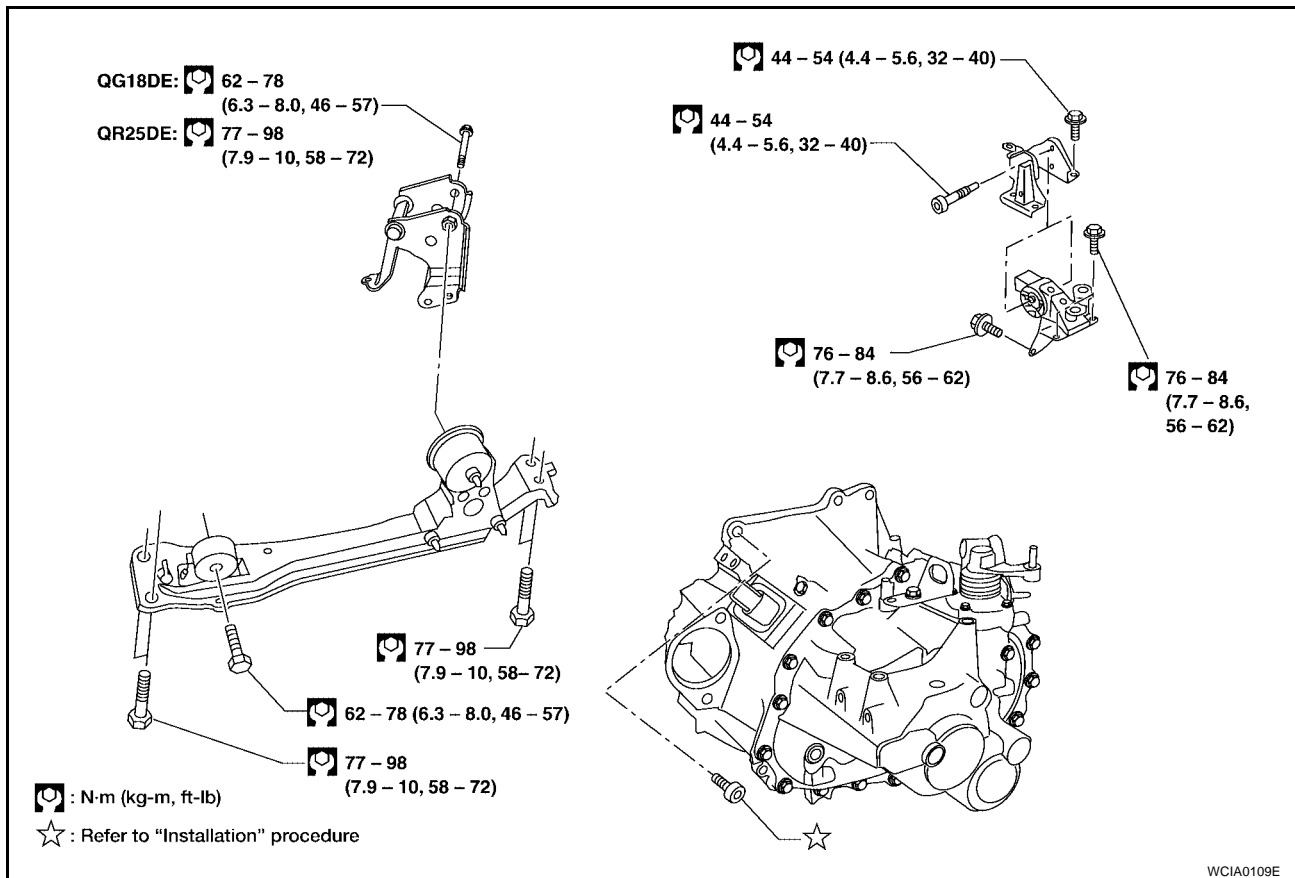

REMOVAL

1. Remove air cleaner and air duct.
 2. Remove battery.
 3. Remove the air breather hose. Refer to [MT-81, "Removal and Installation"](#).
 4. Remove clutch operating cylinder.
- CAUTION:**
Do not depress clutch pedal during removal procedure.
5. Remove engine under cover.
 6. Remove the control cable from the transaxle. Refer to [MT-79, "Removal and Installation of Control Device and Cable"](#).
 7. Drain gear oil from transaxle. Refer to [MT-76, "Replacement"](#).
 8. Disconnect connectors and harnesses for:
 - PNP switch.
 - Speed sensor.
 - Back-up lamp switch.
 - Ground.
 9. Remove the exhaust front tube. Refer to [EX-3, "Removal and Installation"](#).
 10. Remove the drive shafts. Refer to [FAX-14, "Removal"](#).
 11. Remove starter motor. Refer to [SC-20, "Removal and Installation"](#).
 12. Place a jack under the transaxle.

CAUTION:

When setting the jack, be careful not to bring it into contact with the switch.

13. Remove the center member, the engine insulator and the engine mount bracket.

TRANSAXLE ASSEMBLY

[RS5F51A]

14. Support the engine by placing a jack under the oil pan. Do not position the jack so it is in contact with the drain plug.
15. Remove the bolts that mount the engine to the transaxle.
16. Remove the transaxle from the vehicle.

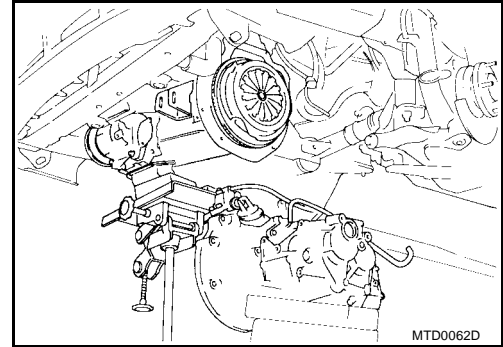

INSTALLATION

Installation is the reverse order of removal.

- When installing the transaxle to the engine, use the tightening torque and sequence shown below:

CAUTION:

When installing transaxle, be careful not to bring transaxle input shaft into contact with the clutch cover.

Bolt No.	1	2	3	4	5	6	7	8	9	10
"ℓ" mm (in)	40	82	47	47	52	40	40	40	30	30
Tightening torque N·m (kg·m, ft·lb)	30 - 40 (3.1 - 4.1, 22 - 29)	70 - 80 (7.1 - 8.1, 52 - 59)				30 - 40 (3.1 - 4.1, 22 - 29)				

- After installation, check oil level, and look for leaks and loose mechanisms.

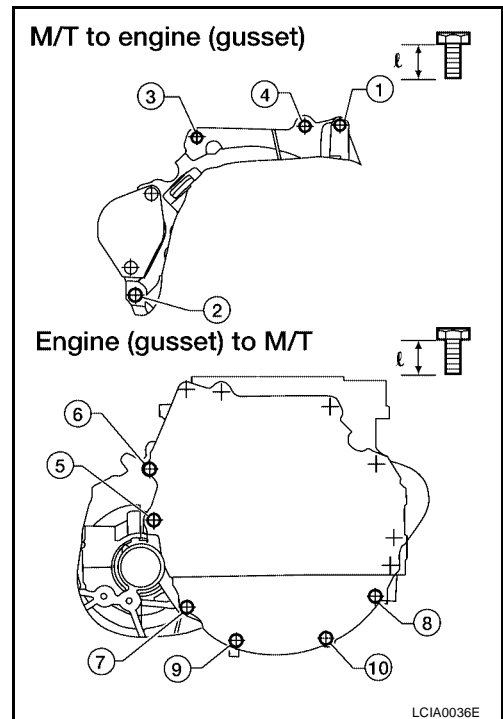

TRANSAXLE ASSEMBLY

[RS5F51A]

ECS005UM

Component Parts CASE AND HOUSING COMPONENTS

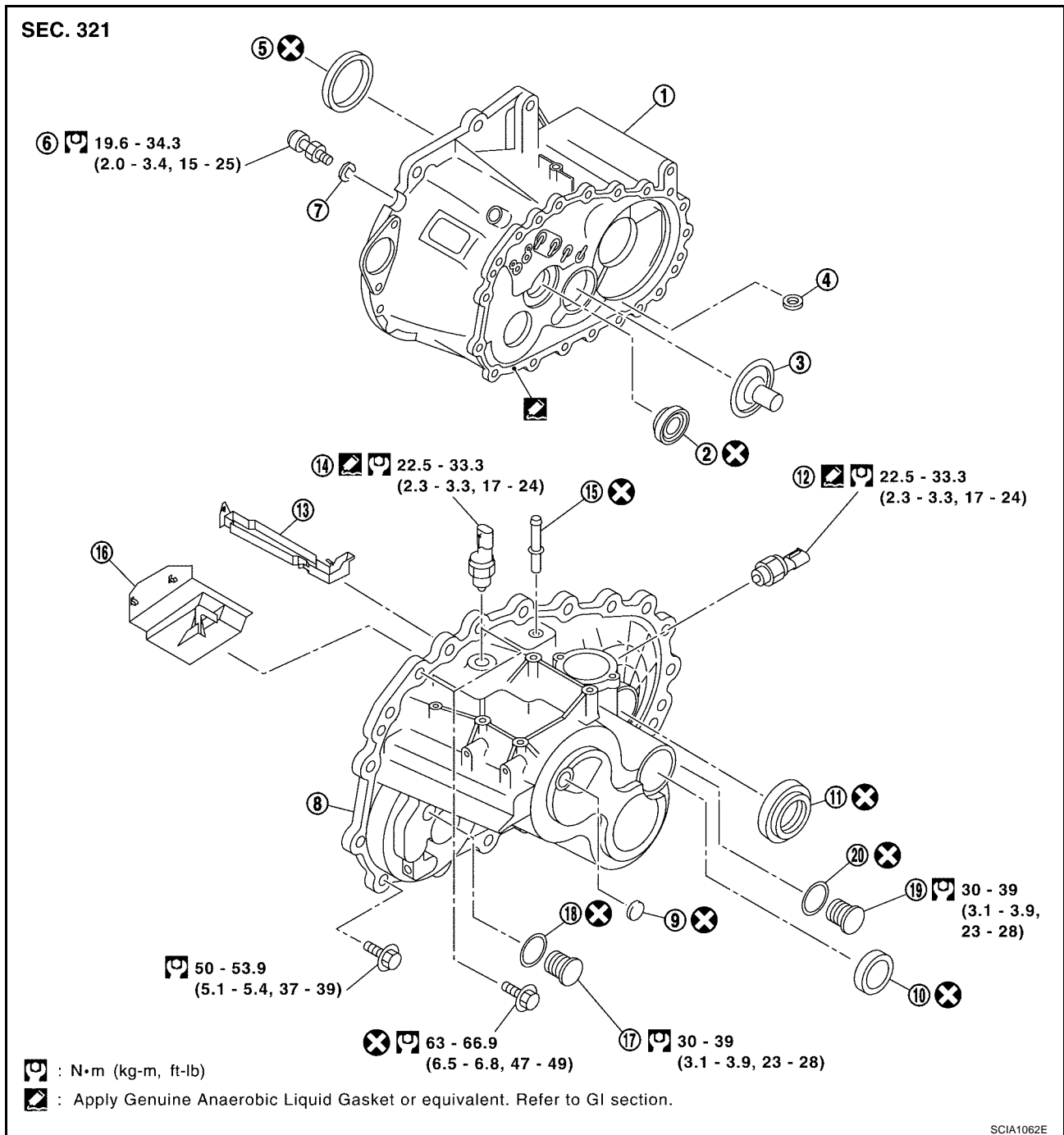

- | | | |
|-------------------|---------------------------|----------------------------------|
| 1. Clutch housing | 2. Input shaft oil seal | 3. Oil channel |
| 4. Magnet | 5. Differential oil seal | 6. Ball pin |
| 7. Washer | 8. Transaxle case | 9. Welch plug |
| 10. Bore plug | 11. Differential oil seal | 12. Park/Neutral position switch |
| 13. Oil gutter | 14. Back-up lamp switch | 15. Air breather tube |
| 16. Baffle plate | 17. Filler plug | 18. Gasket |
| 19. Drain plug | 20. Gasket | |

GEAR COMPONENTS

SEC. 322

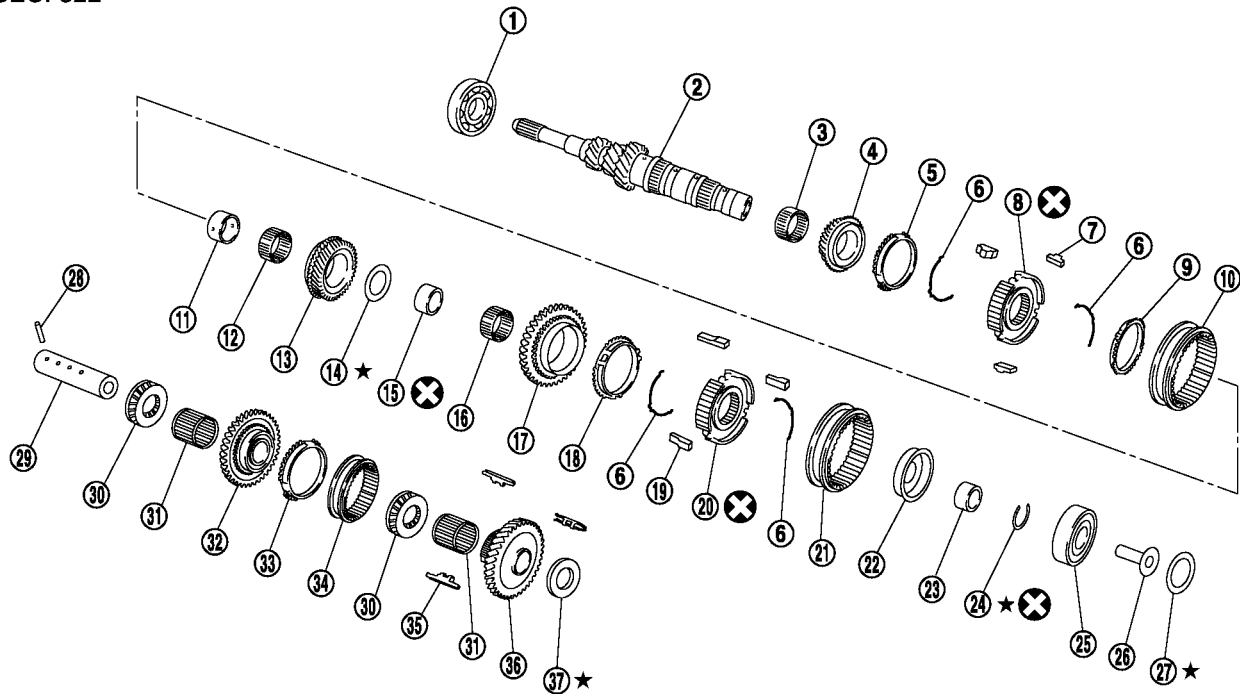

★ : Select proper thickness.

NOTE :

- Apply gear oil to gears, shafts, synchronizers and bearings when assembling.
- Replace (8) and (10), (20) and (21) as a set.

SCIA0385E

- | | | |
|---------------------------------------|--------------------------------|---------------------------------------------|
| 1. Input shaft front bearing | 2. Input shaft | 3. Needle bearing |
| 4. 3rd input gear | 5. 3rd baulk ring | 6. Spread spring |
| 7. 3rd & 4th shifting insert | 8. 3rd & 4th synchronizer hub | 9. 4th baulk ring |
| 10. 3rd & 4th coupling sleeve | 11. Bushing | 12. Needle bearing |
| 13. 4th input gear | 14. Thrust washer | 15. Bushing |
| 16. Needle bearing | 17. 5th input gear | 18. 5th baulk ring |
| 19. 5th shifting insert | 20. 5th synchronizer hub | 21. 5th coupling sleeve |
| 22. 5th stopper | 23. Input shaft bearing spacer | 24. Snap ring |
| 25. Input shaft rear bearing | 26. Oil channel | 27. Input shaft rear bearing adjusting shim |
| 28. Lock pin | 29. Reverse idler shaft | 30. Thrust needle bearing |
| 31. Needle bearing | 32. Reverse idler gear (front) | 33. Reverse baulk ring |
| 34. Reverse coupling sleeve | 35. Insert spring | 36. Reverse idler gear (rear) |
| 37. Reverse idler gear adjusting shim | | |

A
B
MT
D
E
F
G
H
I
J
K
L
M

TRANSAXLE ASSEMBLY

[RS5F51A]

SEC. 322

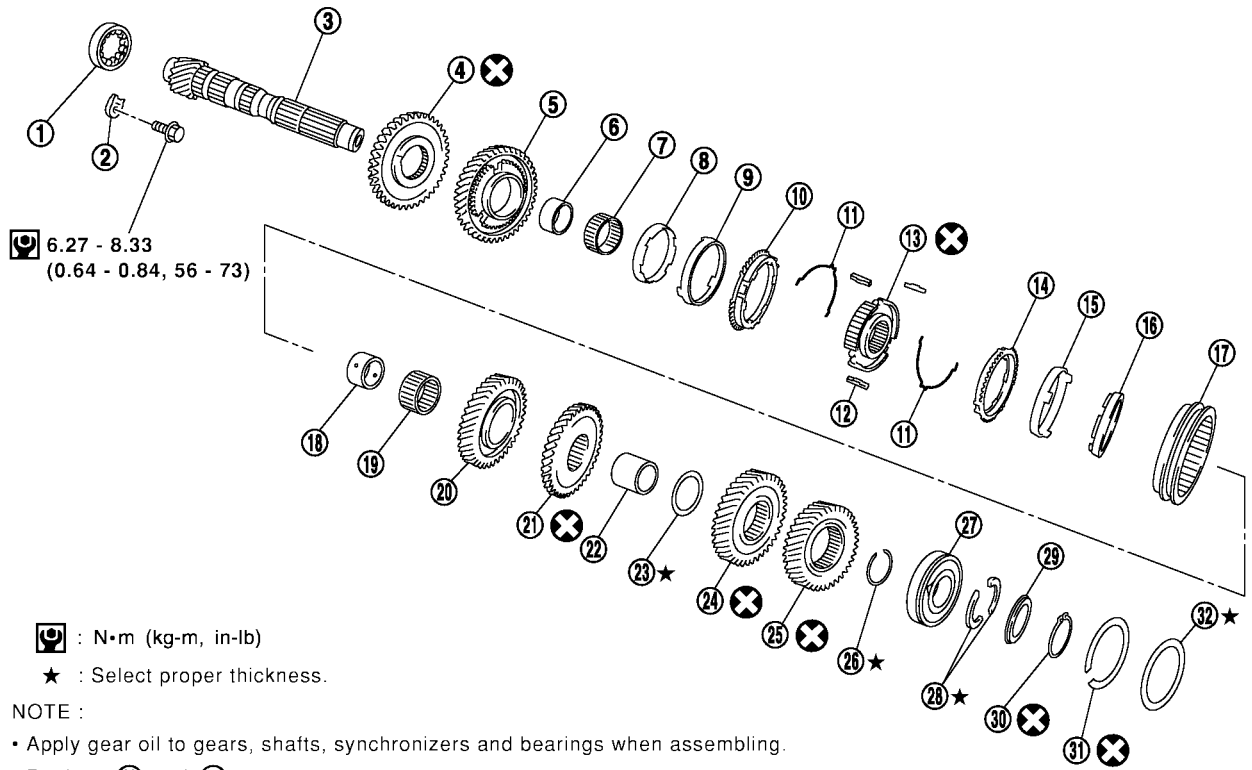

SCIA0386E

- | | | |
|--------------------------------|-------------------------------------------|--------------------------------|
| 1. Mainshaft front bearing | 2. Mainshaft bearing retainer | 3. Mainshaft |
| 4. Reverse main gear | 5. 1st main gear | 6. Bushing |
| 7. Needle bearing | 8. 1st inner baulk ring | 9. 1st gear synchronizer cone |
| 10. 1st outer baulk ring | 11. Spread spring | 12. 1st & 2nd shifting insert |
| 13. 1st & 2nd synchronizer hub | 14. 2nd outer baulk ring | 15. 2nd gear synchronizer cone |
| 16. 2nd inner baulk ring | 17. 1st & 2nd coupling sleeve | 18. Bushing |
| 19. Needle bearing | 20. 2nd main gear | 21. 3rd main gear |
| 22. 3rd & 4th mainshaft spacer | 23. 4th main adjusting shim | 24. 4th main gear |
| 25. 5th main gear | 26. Snap ring | 27. Mainshaft rear bearing |
| 28. Mainshaft C-ring | 29. C-ring holder | 30. Snap ring |
| 31. Snap ring | 32. Mainshaft rear bearing adjusting shim | |

SHIFT CONTROL COMPONENTS

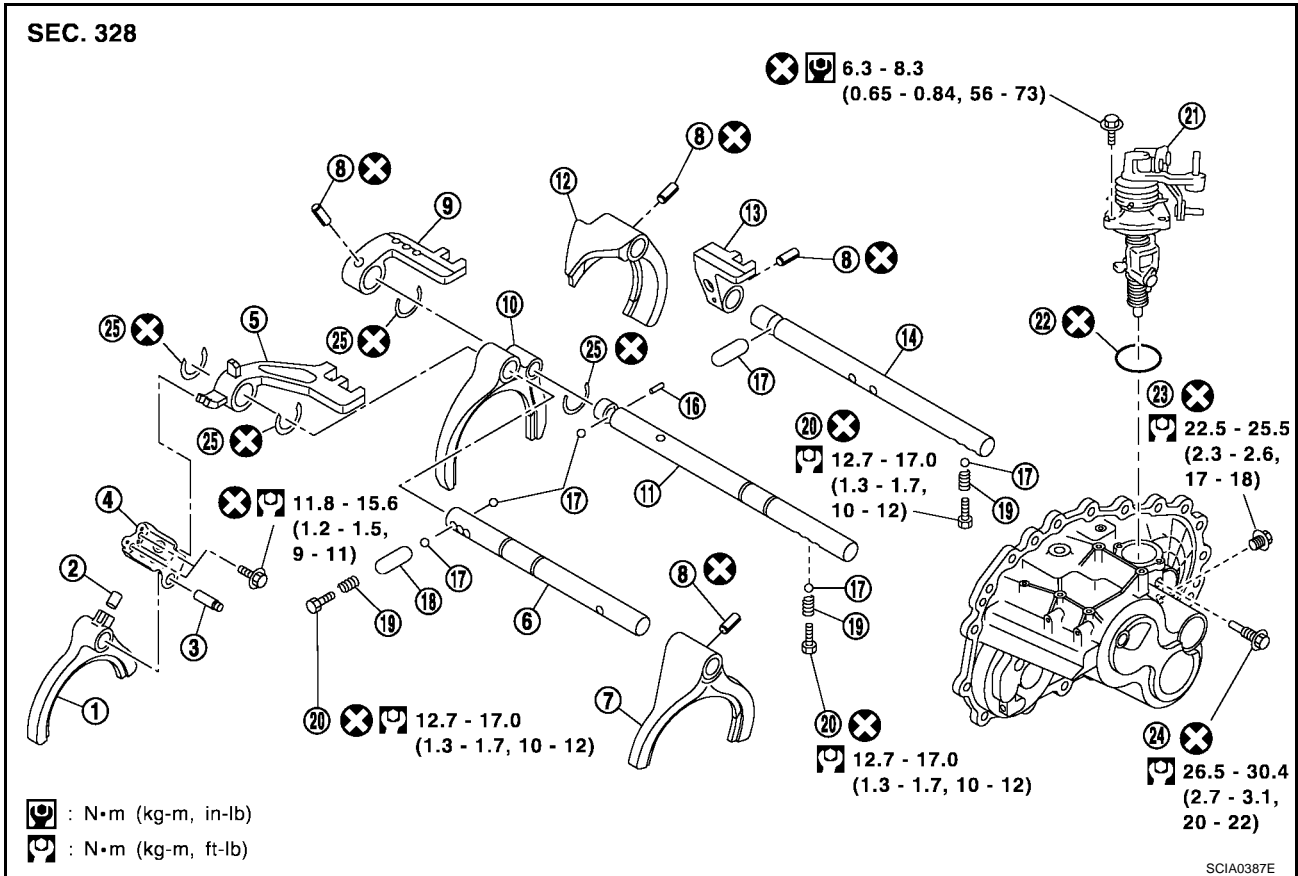

- | | | |
|---------------------------|--------------------------|---------------------------|
| 1. Reverse shift fork | 2. Shifter cap | 3. Reverse fork rod |
| 4. Reverse lever assembly | 5. 5th & reverse bracket | 6. 5th & reverse fork rod |
| 7. 5th shift fork | 8. Retaining pin | 9. 3rd & 4th bracket |
| 10. 3rd & 4th shift fork | 11. 3rd & 4th fork rod | 12. 1st & 2nd shift fork |
| 13. 1st & 2nd bracket | 14. 1st & 2nd fork rod | 15. Shift check sleeve |
| 16. Inter lock pin | 17. Check ball | 18. Shift check sleeve |
| 19. Check spring | 20. Check plug | 21. Control rod assembly |
| 22. O-ring | 23. Shift check | 24. Stopper bolt |
| 25. Stopper ring | | |

FINAL DRIVE COMPONENTS

SEC. 381

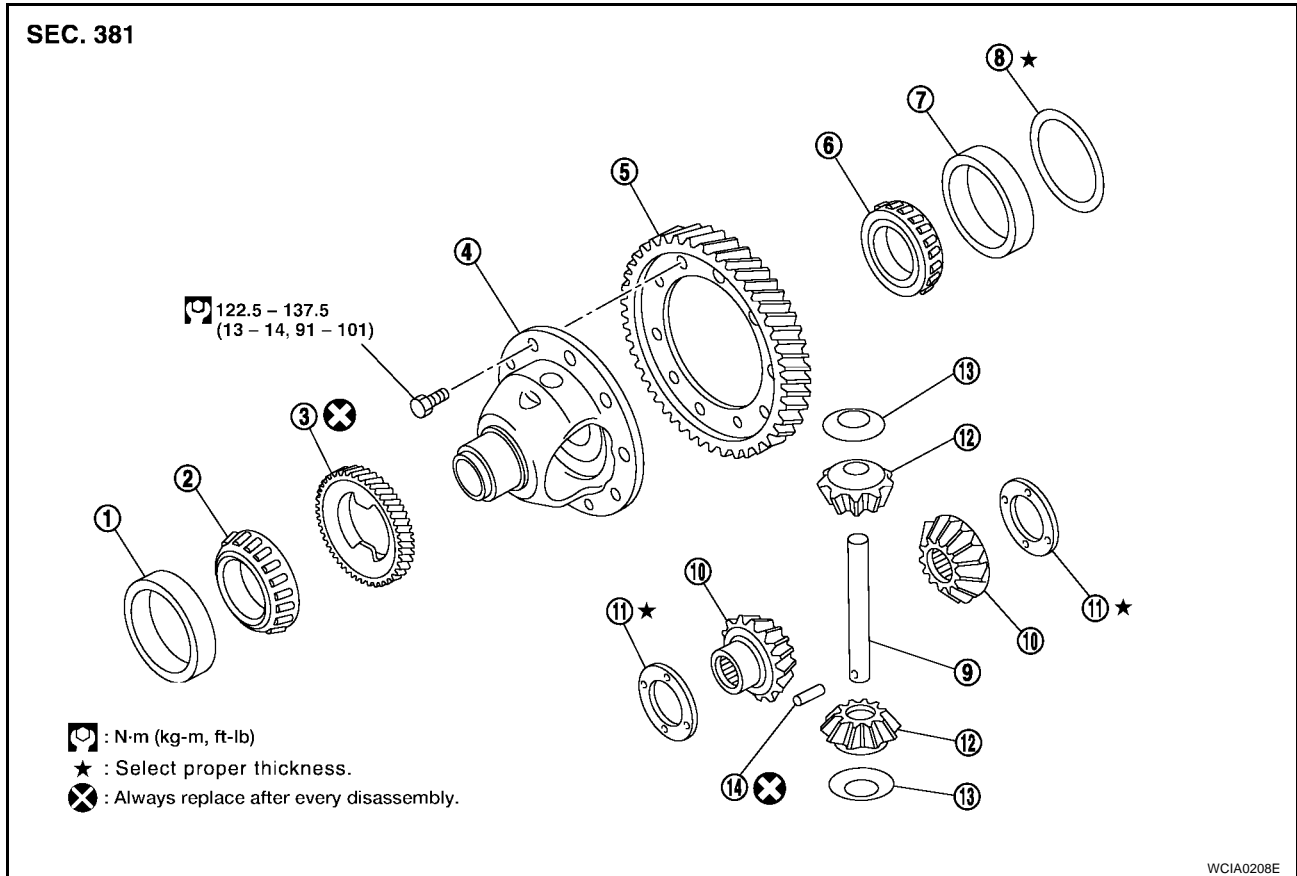

- : N·m (kg·m, ft·lb)
- ★ : Select proper thickness.
- ✕ : Always replace after every disassembly.

- | | | |
|-----------------------------------------|---------------------------------------------|------------------------------|
| 1. Differential side bearing outer race | 2. Differential side bearing | 3. Speedometer drive gear |
| 4. Differential case | 5. Final gear | 6. Differential side bearing |
| 7. Differential side bearing outer race | 8. Differential side bearing adjusting shim | 9. Pinion mate shaft |
| 10. Side gear | 11. Side gear thrust washer | 12. Pinion mate gear |
| 13. Pinion mate gear washer | 14. Retaining pin | |

Disassembly and Assembly

DISASSEMBLY

ECS005UN

1. Remove drain plug and filler plug.
2. Remove park/neutral position switch and back-up lamp switch.
3. After removing shift check and stopper bolt, remove control assembly.

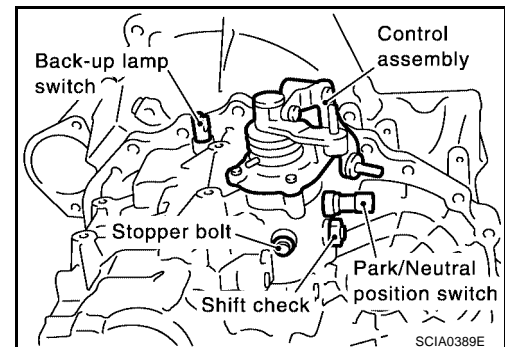

TRANSAXLE ASSEMBLY

[RS5F51A]

4. Remove check plugs (3 pieces), check springs (3 pieces), check balls (3 pieces) and shift check sleeve (1 piece) as shown.

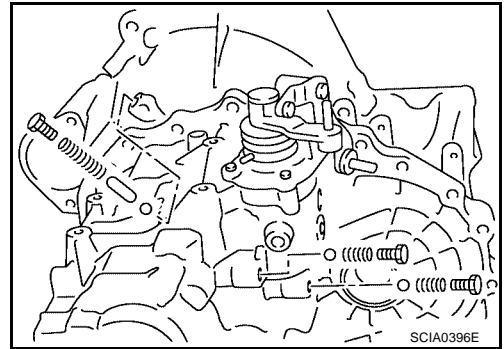

5. Remove transaxle case fixing bolts as shown.

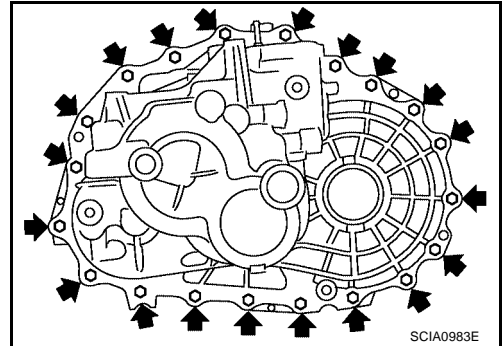

6. Remove bore plug.

CAUTION:

Be careful not to damage transaxle case.

7. While spreading the snap ring of mainshaft rear bearing located at bore plug hole, remove transaxle case.
8. Remove oil gutter, baffle plate.
9. Remove snap ring, mainshaft rear bearing adjusting shim and input shaft rear bearing adjusting shim from transaxle case.
10. Remove differential side bearing outer race (transaxle case side) and the adjustment shim using Tool as shown.

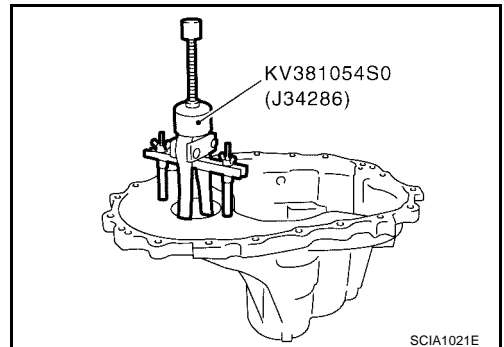

11. Remove the welch plug as shown.

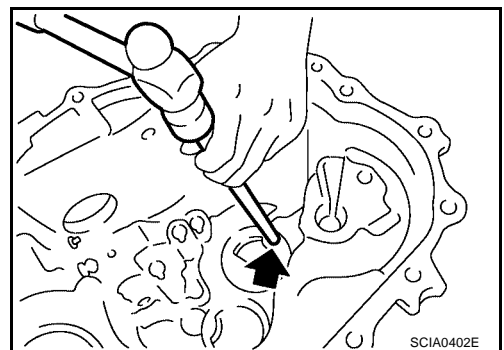

A
B
MT
D
E
F
G
H
I
J
K
L
M

TRANSAXLE ASSEMBLY

[RS5F51A]

12. Remove differential oil seal as shown.

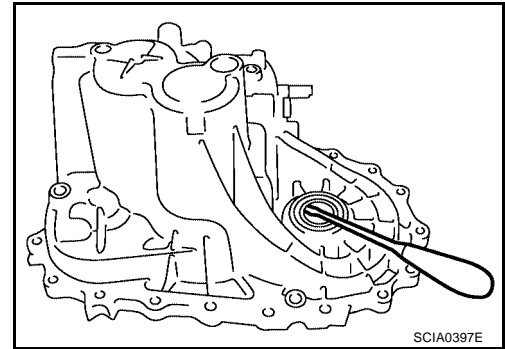

13. Remove magnet from clutch housing.

14. With shift lever in 5th position, remove the bracket bolts from the reverse lever assembly. Lift the reverse lever assembly to remove.

CAUTION:

Be careful not to lose shifter cap.

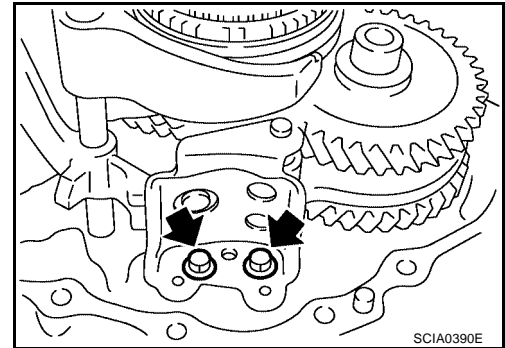

15. Pull out reverse fork rod then remove reverse shift fork.

16. Shift 3rd & 4th fork rod to 3rd position. Remove retaining pin of 5th shift fork using pin punch.

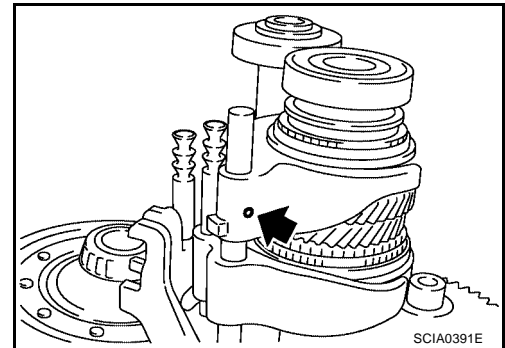

17. Remove stopper rings for 5th & reverse bracket.

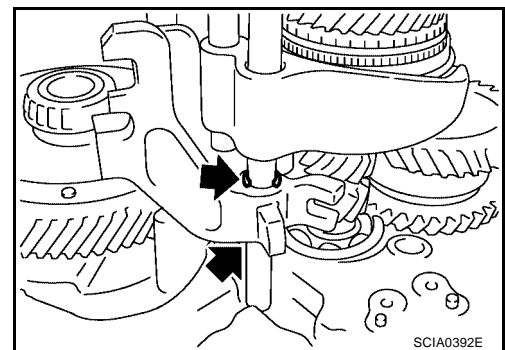

18. Pull out 5th & reverse fork rod and remove 5th shift fork and 5th & reverse bracket.

19. Remove check balls (2 pieces) and inter lock pin.

TRANSAXLE ASSEMBLY

[RS5F51A]

20. Remove retaining pin of 3rd & 4th bracket using pin punch.

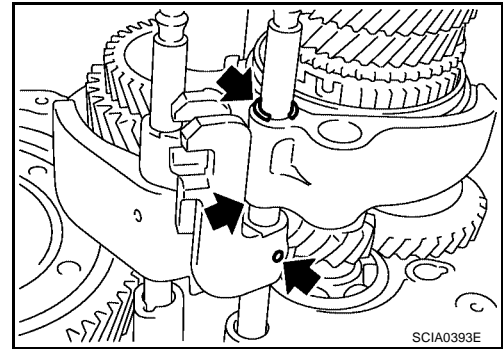

21. Remove stopper rings for 3rd & 4th shift fork.
22. Pull out 3rd & 4th fork rod and remove 3rd & 4th shift fork and bracket.
23. Remove shift check sleeve from clutch housing.
24. Remove retaining pin of 1st & 2nd shift fork using pin punch.

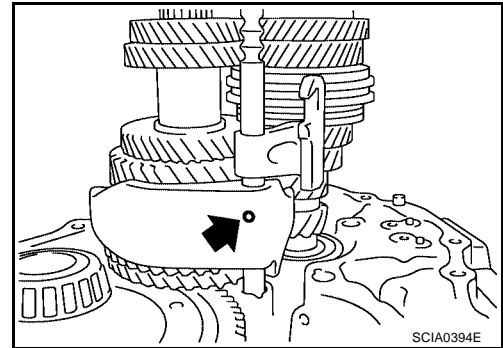

25. Pull out 1st & 2nd shift fork with bracket.
26. Remove 1st & 2nd shift fork.
27. Remove retaining pin of 1st & 2nd bracket using pin punch and separate 1st & 2nd fork rod and bracket.
28. Remove gear components from clutch housing.

- a. While tapping input shaft with plastic hammer, remove input shaft assembly, mainshaft assembly and reverse idler gear assembly as a set.

CAUTION:

Always withdraw mainshaft straight out. Failure to do so can damage resin oil channel on clutch housing side.

- b. Remove final drive assembly.

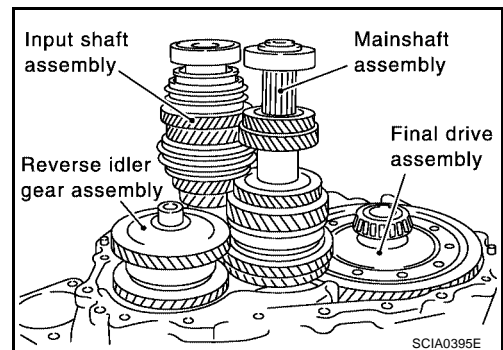

29. Remove mainshaft bearing retainer and then the mainshaft front bearing using Tool as shown.

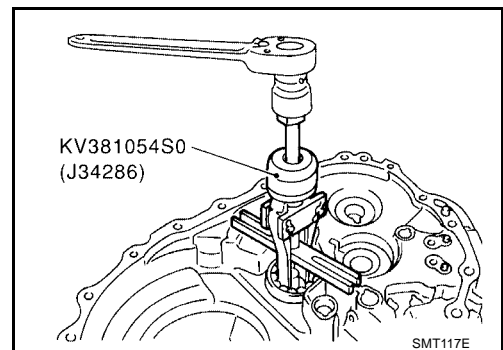

30. Remove oil channel on mainshaft side.
31. Remove differential oil seal (clutch housing side).

TRANSAXLE ASSEMBLY

[RS5F51A]

32. Remove differential side bearing outer race (clutch housing side).

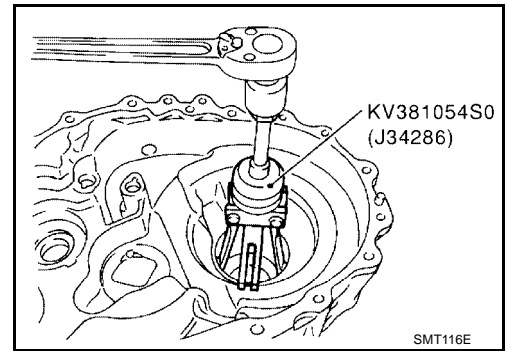

33. Remove input shaft oil seal.

CAUTION:
Be careful not to damage clutch housing.

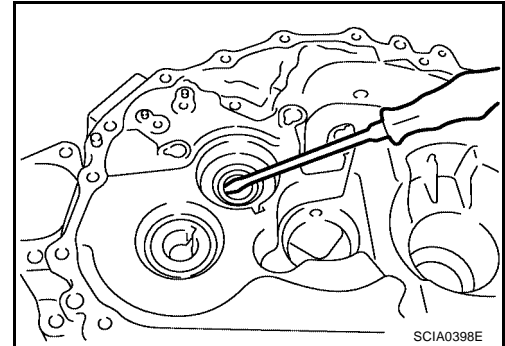

ASSEMBLY

1. Install a new input shaft oil seal from the clutch housing end, to a depth of 1.8 - 2.8 mm (0.071 - 0.110 in) using Tool as shown.

CAUTION:
Oil seals are not reusable.

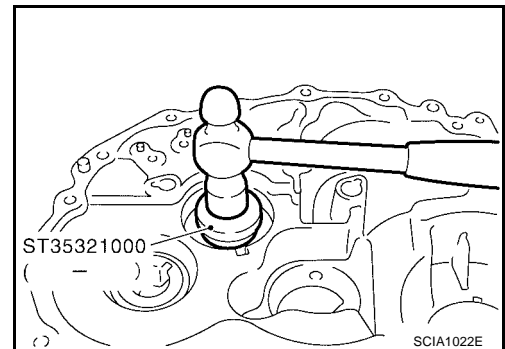

2. Install a new differential oil seal using Tool as shown.

CAUTION:
Oil seals are not reusable.

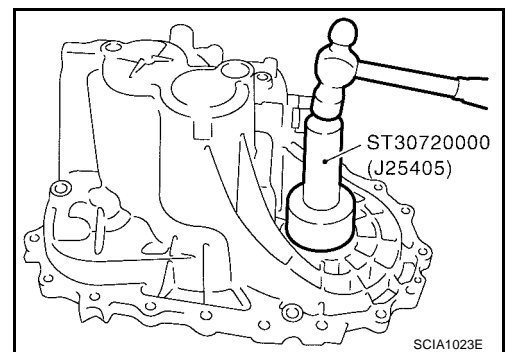

TRANSAXLE ASSEMBLY

[RS5F51A]

3. Install oil channel on mainshaft side.

CAUTION:

Position oil channel with specified orientation for installation as shown.

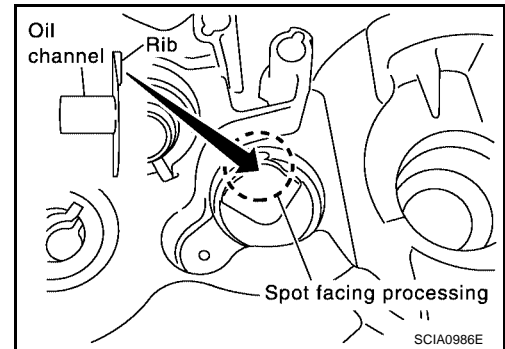

4. Install mainshaft front bearing using Tool as shown.

CAUTION:

Install with orientation as shown.

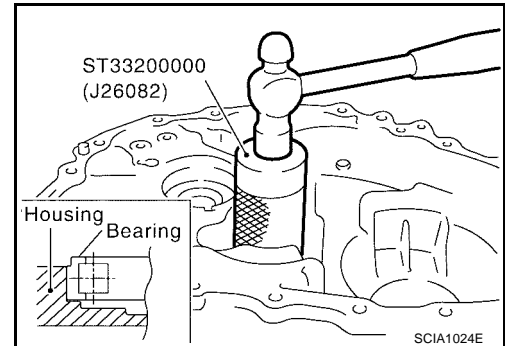

5. Install bearing retainer for mainshaft front bearing.

Bearing retainer bolt : 6.27 - 8.33 N·m (0.64 - 0.84 kg·m, 56 - 73 in·lb)

CAUTION:

Install with the punched surface facing up.

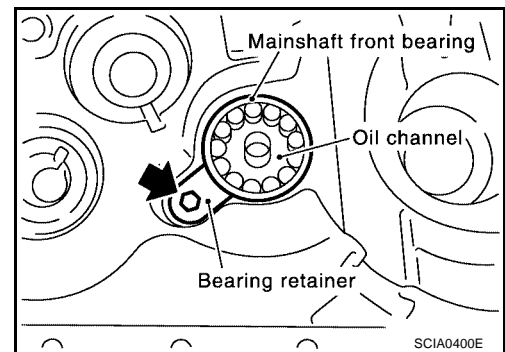

6. Install differential side bearing outer race using Tool as shown.

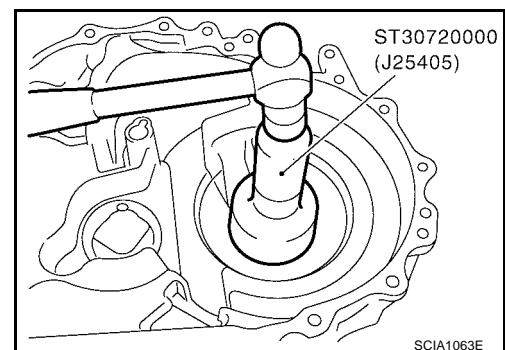

7. Install final drive assembly into clutch housing.

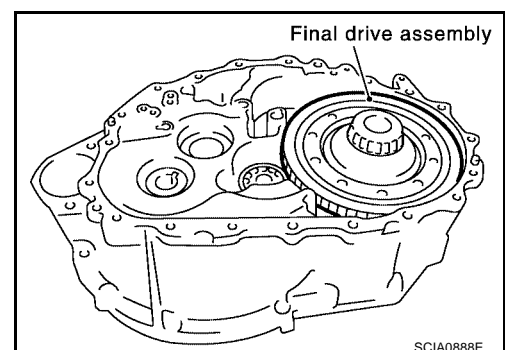

A

B

MT

D

E

F

G

H

I

J

K

L

M

TRANSAXLE ASSEMBLY

[RS5F51A]

8. Install input shaft assembly, mainshaft assembly, and reverse idler gear assembly into clutch housing.

CAUTION:

Be sure not to damage input shaft oil seal.

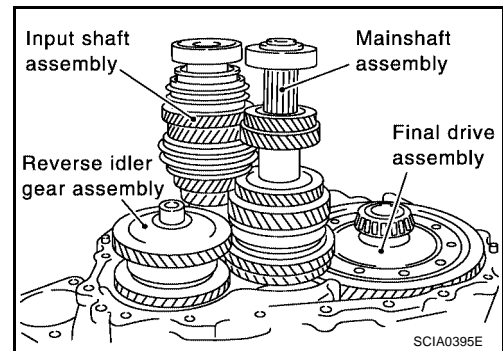

9. Install 1st-2nd fork rod bracket onto 1st-2nd fork rod, and then install a new retaining pin.

CAUTION:

Retaining pins are not reusable.

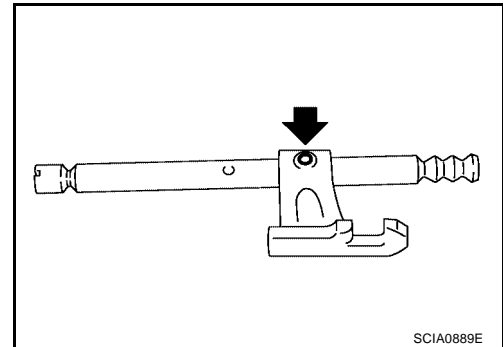

10. Install 1st-2nd fork rod and 1st-2nd shift fork, and then install a new retaining pin.

CAUTION:

Retaining pins are not reusable.

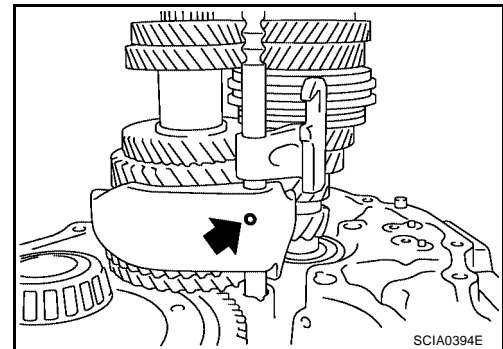

11. Install shift check sleeve.

12. Install 3rd-4th bracket, 3rd-4th shift fork, and 3rd-4th fork rod with interlock pin.

13. Install a new stopper ring onto 3rd-4th shift fork.

CAUTION:

Stopper rings are not reusable.

14. Install a new retaining pin onto 3rd-4th bracket.

CAUTION:

Retaining pins are not reusable.

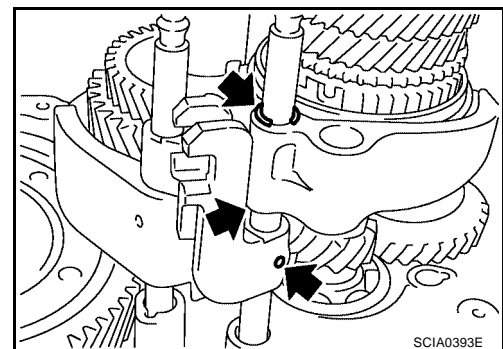

15. Install 2 check balls.

TRANSAXLE ASSEMBLY

[RS5F51A]

16. Install 5th-reverse bracket, 5th shift fork, and 5th-reverse fork rod.
17. Install a new stopper ring onto 5th-reverse bracket.

CAUTION:

Stopper rings are not reusable.

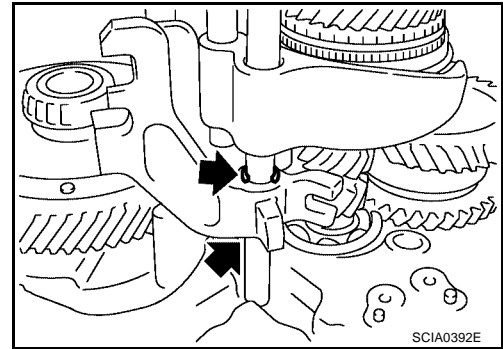

18. Install a new retaining pin onto 5th shift fork.

CAUTION:

Retaining pins are not reusable.

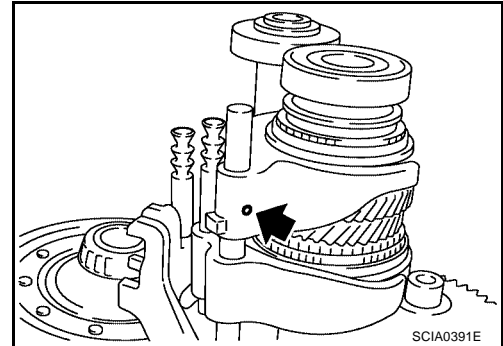

19. Install reverse shift fork and reverse fork rod.
20. Install reverse lever assembly following procedures below.
 - a. Install shifter cap onto reverse lever assembly cam, and then install them onto reverse shift fork.

CAUTION:

Do not drop shifter cap.

- b. While lifting reverse shift fork, align cam with 5th-reverse fork rod bracket.

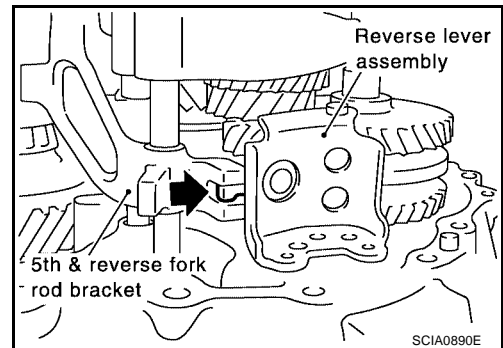

- c. Install the reverse lever assembly and tighten the reverse lever assembly bolts to specification.

Reverse lever assembly bolts : 11.8 - 15.6 N-m (1.2 - 1.5 kg-m, 9 - 11 ft-lb)

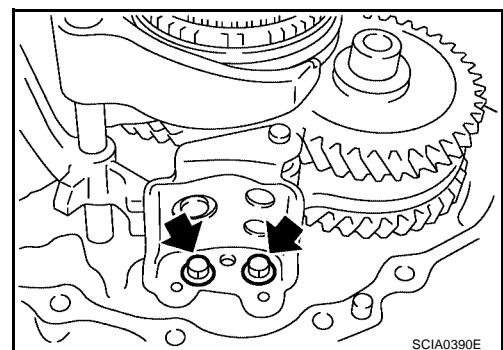

21. Install the magnet onto clutch housing.
22. Install selected input shaft adjusting shim onto input shaft.
 - For selection of adjusting shims, refer to [MT-98, "INPUTSHAFT END PLAY"](#).
23. Install baffle plate and oil gutter.
24. Install transaxle case following procedures below.

TRANSAXLE ASSEMBLY

[RS5F51A]

- a. Install selected mainshaft rear bearing adjusting shim into transaxle case.
 - For selection of adjusting shims, refer to [MT-100, "MAINSHAFT END PLAY"](#) .
- b. Temporarily install a new snap ring for the mainshaft rear bearing into transaxle case.

CAUTION:

Do not reuse the snap ring.

- c. Apply sealant to mating surfaces of transaxle case and clutch housing. Use Genuine Anaerobic Liquid Gasket or equivalent. Refer to [GI-44, "Recommended Chemical Products and Sealants"](#) .

CAUTION:

Remove old sealant adhering to mounting surfaces. Also remove any moisture, oil, or foreign material adhering to application and mounting surfaces.

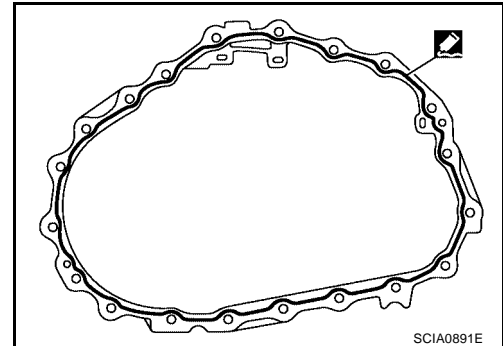

- d. With snap ring of mainshaft rear bearing temporarily installed, place transaxle case over clutch housing as shown.

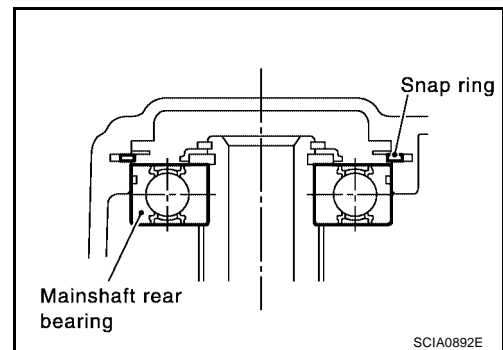

- e. Through bore plug mounting hole, with snap ring stretched, and lift up mainshaft assembly from the control assembly mounting hole.
- f. Securely install snap ring onto mainshaft rear bearing as shown.

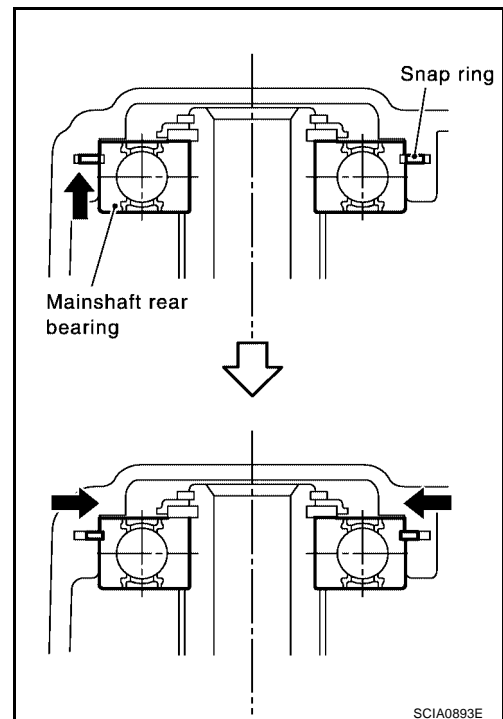

TRANSAXLE ASSEMBLY

[RS5F51A]

- g. Tighten mounting bolts "A" and "B" to specification as shown.

Bolt A : 50.0 - 53.9 N·m (5.1 - 5.4 kg·m, 37 - 39 ft·lb)

Bolt B : 63.0 - 66.9 N·m (6.5 - 6.8 kg·m, 47 - 49 ft·lb)

CAUTION:

Always replace bolts "B" as they are self-sealing bolts.

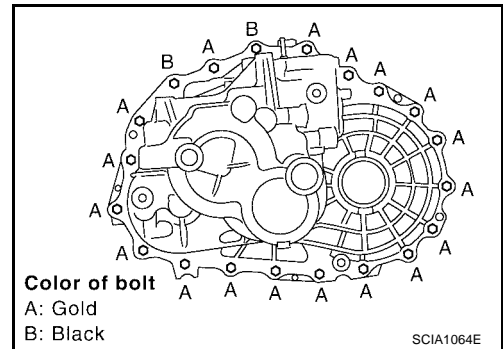

- h. Install control assembly.

CAUTION:

Do not reuse the O-ring.

- i. Install a new shift check and a new stopper bolt.

CAUTION:

Shift check and stopper bolt are not reusable.

25. Install a new bore plug using Tool as shown.

CAUTION:

Bore plugs are not reusable.

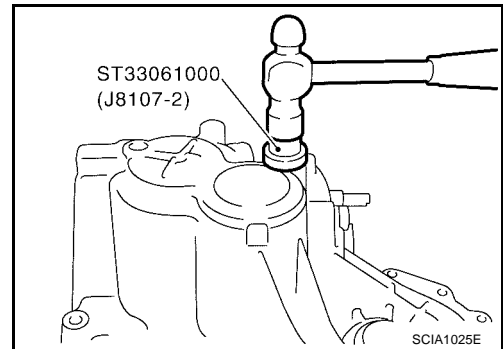

26. Install a new welch plug using Tool as shown.

CAUTION:

Do not reuse the welch plug.

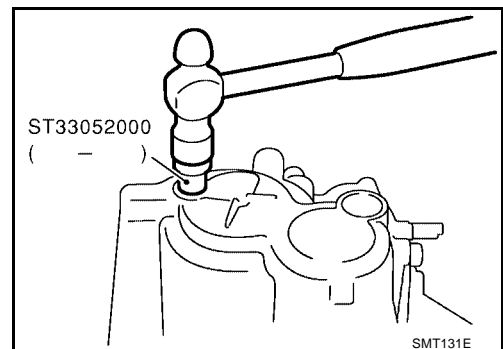

27. Install 1 shift check sleeve, 3 check balls, 3 check springs, and 3 new check ball plugs as shown.

CAUTION:

Check ball plugs are not reusable.

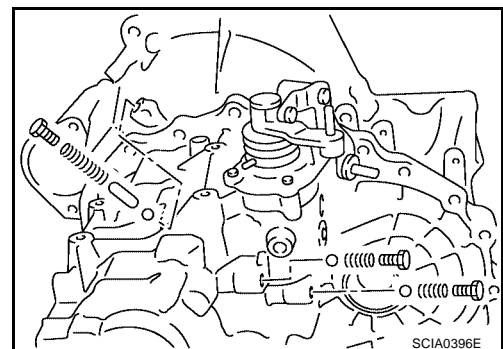

TRANSAXLE ASSEMBLY

[RS5F51A]

28. Apply sealant to threads of PNP switch and back-up lamp switch, then install them into transaxle case. Use Genuine Anaerobic Liquid Gasket or equivalent. Refer to [GI-44, "Recommended Chemical Products and Sealants"](#).

29. Install new gaskets onto drain plug and filler plug, and then install them into transaxle case.

CAUTION:

- Gaskets are not reusable.
- After oil is filled, tighten filler plug to specified torque.

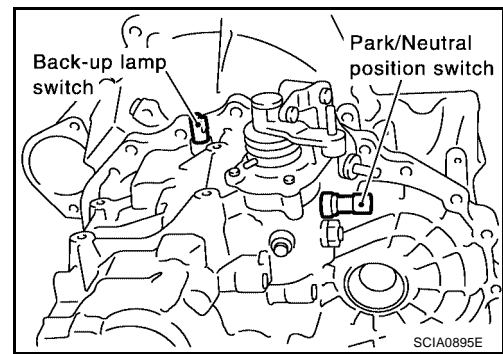

ECS005UO

Adjustment INPUTSHAFT END PLAY

- When adjusting input shaft end play, select adjusting shim for input shaft bearing. To select adjusting shim, measure clearance between transaxle case and input shaft rear bearing.
- Calculate dimension "O" (thickness of adjusting shim) using the following procedure to meet specification of end play for input shaft rear bearing.

End play : 0 - 0.06 mm (0 - 0.0024 in)

Dimension "O" = (O₁ - O₂) + End play

O : Thickness of adjusting shim

O₁ : Distance between transaxle case end face and mounting face of adjusting shim

O₂ : Distance between clutch housing case end face and end face of input shaft rear bearing

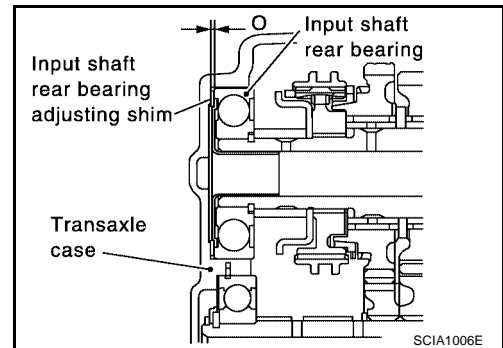

Adjusting Shim

Shim thickness	Part number	Shim thickness	Part number	Shim thickness	Part number
0.40 mm (0.0157 in)	32225 8H500	0.88 mm (0.0346 in)	32225 8H512	1.36 mm (0.0520 in)	32225 8H524
0.44 mm (0.0173 in)	32225 8H501	0.92 mm (0.0362 in)	32225 8H513	1.40 mm (0.0551 in)	32225 8H560
0.48 mm (0.0189 in)	32225 8H502	0.96 mm (0.0378 in)	32225 8H514	1.44 mm (0.0567 in)	32225 8H561
0.52 mm (0.0205 in)	32225 8H503	1.00 mm (0.0396 in)	32225 8H515	1.48 mm (0.0583 in)	32225 8H562
0.56 mm (0.0220 in)	32225 8H504	1.04 mm (0.0409 in)	32225 8H516	1.52 mm (0.0598 in)	32225 8H563
0.60 mm (0.0236 in)	32225 8H505	1.08 mm (0.0425 in)	32225 8H517	1.56 mm (0.0614 in)	32225 8H564
0.64 mm (0.0252 in)	32225 8H506	1.12 mm (0.0441 in)	32225 8H518	1.60 mm (0.0630 in)	32225 8H565
0.68 mm (0.0268 in)	32225 8H507	1.16 mm (0.0457 in)	32225 8H519	1.64 mm (0.0646 in)	32225 8H566
0.72 mm (0.0283 in)	32225 8H508	1.20 mm (0.0472 in)	32225 8H520	1.68 mm (0.0661 in)	32225 8H567
0.76 mm (0.0299 in)	32225 8H509	1.24 mm (0.0488 in)	32225 8H521	1.72 mm (0.0677 in)	32225 8H568
0.80 mm (0.0315 in)	32225 8H510	1.28 mm (0.0504 in)	32225 8H522		
0.84 mm (0.0331 in)	32225 8H511	1.32 mm (0.0520 in)	32225 8H523		

CAUTION:

Only 1 adjusting shim can be selected.

1. Using depth micrometer and straight edge, measure dimension "O₁" between transaxle case end face and mounting face of adjusting shim as shown.

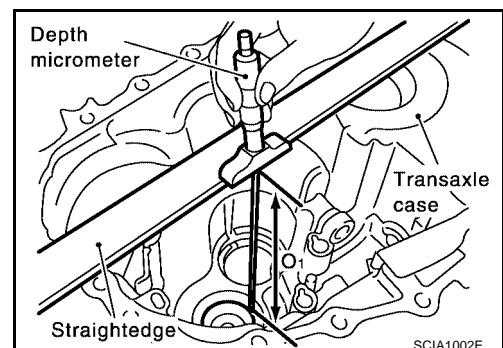

- Using depth micrometer and straight edge, measure dimension "O₂" between clutch housing case end face and end face of input shaft rear bearing as shown.

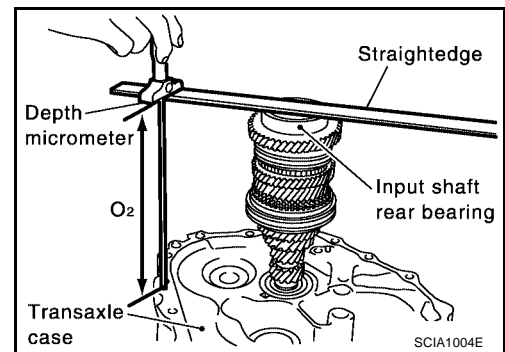

- Install selected input shaft rear bearing adjusting shim onto input shaft.

DIFFERENTIAL SIDE BEARING PRELOAD

- When adjusting differential side bearing preload, select adjusting shim for differential side bearing. To select adjusting shim, measure clearance "L" between transaxle case and differential side bearing outer race.
- Calculate dimension "L" (thickness of adjusting shim) using the following procedure to meet specification of preload for differential side bearing.

Preload : 0.15 - 0.21 mm (0.0059 - 0.0083 in)

Dimension "L" = (L₁ - L₂) + Preload

L : Thickness of adjusting shim

L₁ : Distance between clutch housing case end face and mounting face of adjusting shim

L₂ : Distance between differential side bearing and transaxle case

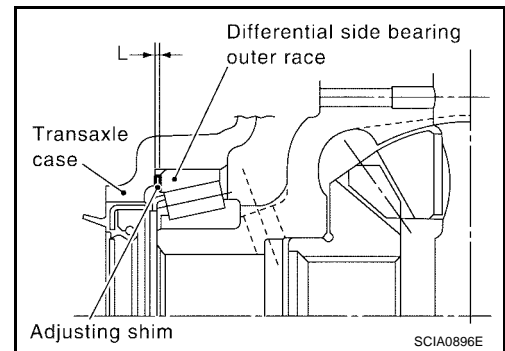

Adjusting Shim

Shim thickness	Part number
0.48 mm (0.0189 in)	31438 80X00
0.52 mm (0.0205 in)	31438 80X01
0.56 mm (0.0220 in)	31438 80X02
0.60 mm (0.0236 in)	31438 80X03
0.64 mm (0.0252 in)	31438 80X04
0.68 mm (0.0268 in)	31438 80X05
0.72 mm (0.0283 in)	31438 80X06
0.76 mm (0.0299 in)	31438 80X07
0.80 mm (0.0315 in)	31438 80X08
0.84 mm (0.0331 in)	31438 80X09
0.88 mm (0.0346 in)	31438 80X10
0.92 mm (0.0362 in)	31438 80X11

CAUTION:

Up to 2 adjusting shims can be selected.

- Using depth micrometer and straight edge, measure dimension "L₁" between clutch housing case end face and mounting face of adjusting shim as shown.

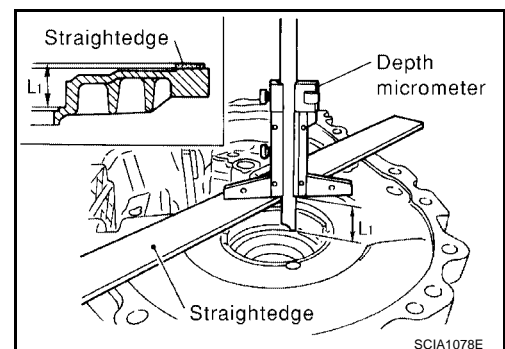

TRANSAXLE ASSEMBLY

[RS5F51A]

2. Install outer race onto differential side bearing on final gear side. Holding the outer race horizontally by hand, rotate final gear five times or more (for smooth movement of bearing roller).
3. Using depth micrometer and straight edge, measure dimension "L2" between differential side bearing outer race and transaxle case end face as shown.

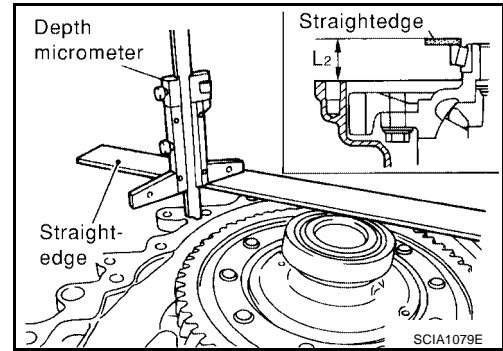

4. Install selected adjusting shim and then differential side bearing outer race using Tool as shown.

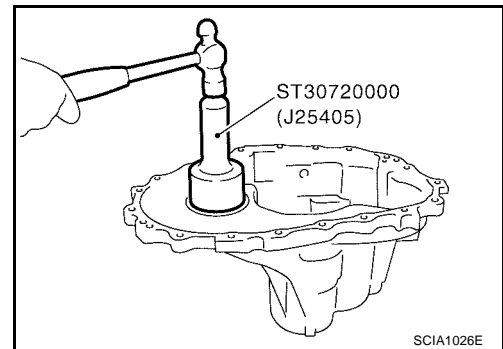

MAINSHAFT END PLAY

- When adjusting mainshaft end play, select adjusting shim for mainshaft rear bearing. To select adjusting shim, measure clearance "M" between transaxle case and mainshaft rear bearing.
- Calculate dimension "P" (thickness of adjusting shim) using the following procedure to meet specification of end play for mainshaft rear bearing.

End play : 0 - 0.06 mm (0 - 0.0024 in)

Dimension "P" = "M" + End play

P : Thickness of adjusting shim

M : Distance between mainshaft rear bearing and transaxle case

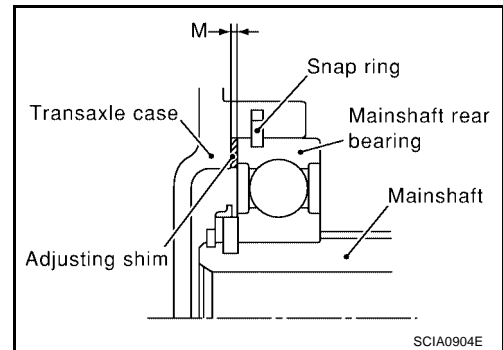

Adjusting Shim

Shim thickness	Part number
0.44 mm (0.0173 in)	32238 8H510
0.48 mm (0.0189 in)	32238 8H511
0.52 mm (0.0205 in)	32238 8H512
0.56 mm (0.0220 in)	32238 8H513
0.60 mm (0.0236 in)	32238 8H514
0.64 mm (0.0252 in)	32238 8H515
0.68 mm (0.0268 in)	32238 8H516
0.72 mm (0.0283 in)	32238 8H517
0.76 mm (0.0299 in)	32238 8H518
0.80 mm (0.0315 in)	32238 8H519
0.84 mm (0.0331 in)	32238 8H520
0.88 mm (0.0346 in)	32238 8H521
0.92 mm (0.0362 in)	32238 8H522
0.96 mm (0.0378 in)	32238 8H523
1.00 mm (0.0396 in)	32238 8H524
1.04 mm (0.0409 in)	32238 8H560
1.08 mm (0.0425 in)	32238 8H561

CAUTION:

Only 1 adjusting shim can be selected.

1. Install mainshaft assembly to clutch housing.
2. Install snap ring to transaxle case.
3. Install transaxle case to clutch housing, and temporarily assemble them with fixing bolts. Install snap ring temporarily to mainshaft rear bearing.
4. Install dial gauge to snap ring access hole, and expand snap ring. Lift mainshaft assembly through control assembly installation hole, and push it against transaxle case. This state shall be defined as base. Moving distance of mainshaft assembly, with snap ring fit on main bearing, becomes "M".

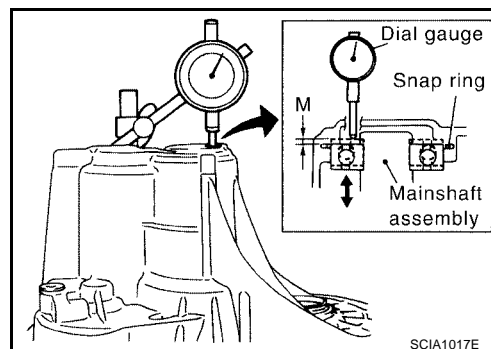

REVERSE IDLER GEAR END PLAY

- When adjusting reverse idler gear end play, select adjusting shim for reverse idler gear. To select adjusting shim, measure clearance between transaxle case and reverse idler gear.
- Calculate dimension "Q" (thickness of adjusting shim) using the following procedure to meet specification of end play for reverse idler gear.

End play : 0.04 - 0.14 mm (0.0016 - 0.0055 in)

Dimension "Q" = (Q1 - Q2) + End play

Q : Thickness of adjusting shim

Q1 : Distance between transaxle case end face and mounting face of adjusting shim

Q2 : Distance between clutch housing case end face and end face of reverse idler gear

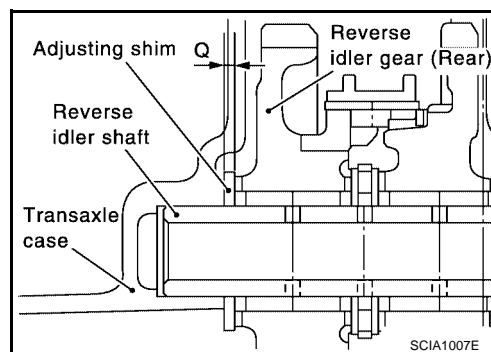

Adjusting Shim

Shim thickness	Part number
1.76 mm (0.0693 in)	32237 8H500
1.84 mm (0.0724 in)	32237 8H501
1.92 mm (0.0756 in)	32237 8H502
2.00 mm (0.0787 in)	32237 8H503
2.08 mm (0.0819 in)	32237 8H504
2.16 mm (0.0850 in)	32237 8H505
2.24 mm (0.0882 in)	32237 8H506
2.32 mm (0.0913 in)	32237 8H507
2.40 mm (0.0945 in)	32237 8H508
2.48 mm (0.0976 in)	32237 8H509
2.56 mm (0.1008 in)	32237 8H510
2.64 mm (0.1039 in)	32237 8H511

CAUTION:

Only 1 adjusting shim can be selected.

- Using depth micrometer and straight edge, measure dimension "Q1" between transaxle case end face and mounting face of adjusting shim as shown.

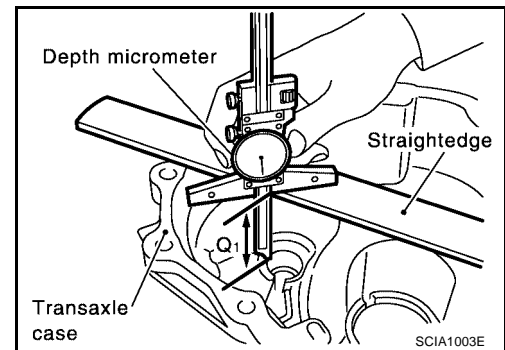

- Using depth micrometer and straight edge, measure dimension "Q2" between clutch housing case end face and end face of reverse idler gear as shown.

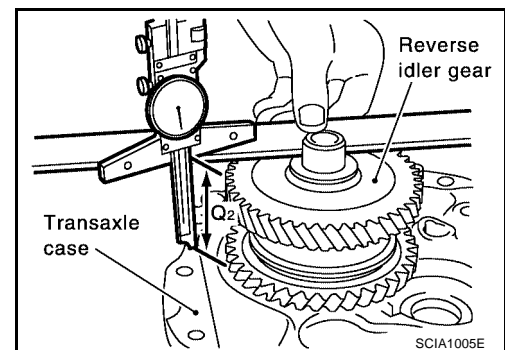

- Install selected reverse idler gear adjusting shim onto reverse idler gear.

INPUT SHAFT AND GEARS

Disassembly and Assembly

DISASSEMBLY

1. Before disassembling, measure the end play for 3rd, 4th, and 5th input gears as shown.

End play standard range

3rd gear : 0.18 - 0.31 mm (0.0071 - 0.0122 in)

4th gear : 0.20 - 0.30 mm (0.0079 - 0.0118 in)

5th gear : 0.06 - 0.16 mm (0.0024 - 0.0063 in)

CAUTION:

If measurement is outside the standard range, disassemble to check contact surfaces of gear, shaft, and hub. Adjust with snap ring at assembly.

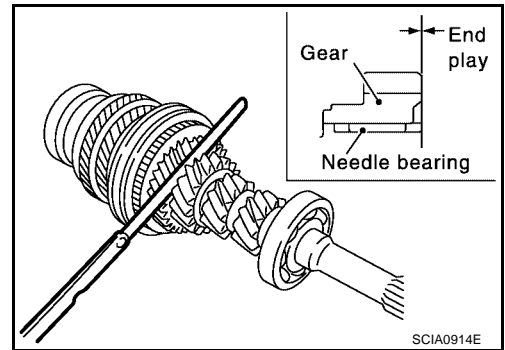

2. Remove the oil channel.
3. Remove the input shaft rear bearing using Tool as shown.

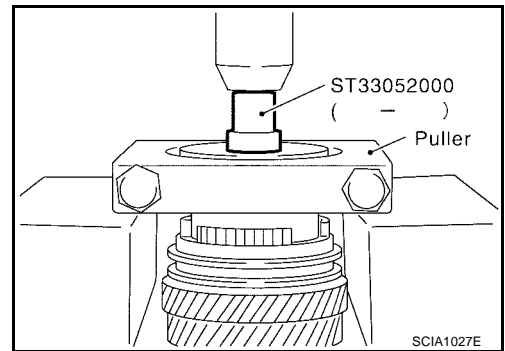

4. Remove the snap ring as shown.

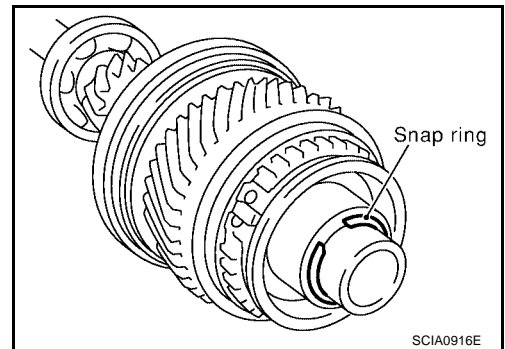

5. Remove input shaft bearing spacer and 5th stopper simultaneously using Tool as shown.

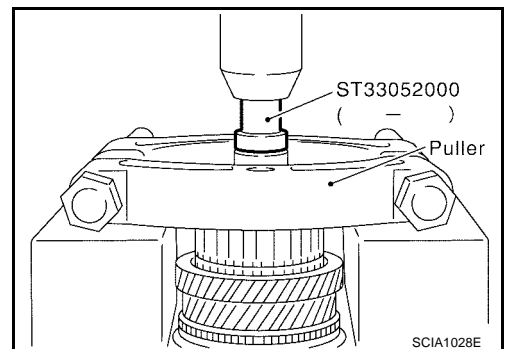

A
B
MT
D
E
F
G
H
I
J
K
L
M

INPUT SHAFT AND GEARS

[RS5F51A]

6. Remove 5th input gear and synchronizer hub assembly simultaneously using Tool as shown.
7. Remove 5th needle bearing.

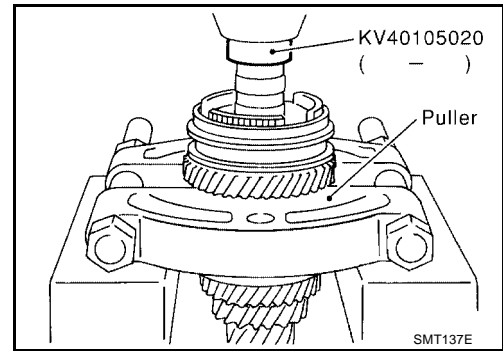

8. Remove 5th bushing, thrust washer, 4th input gear, 4th needle bearing, 4th bushing, 4th baulk ring, 3rd-4th synchronizer hub assembly, 3rd baulk ring and 3rd input gear simultaneously using Tool as shown.
9. Remove 3rd needle bearing.

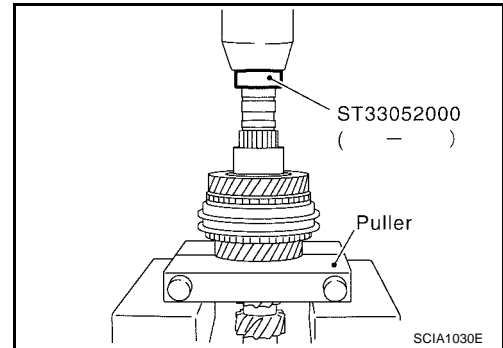

10. Remove input shaft front bearing using Tool as shown.

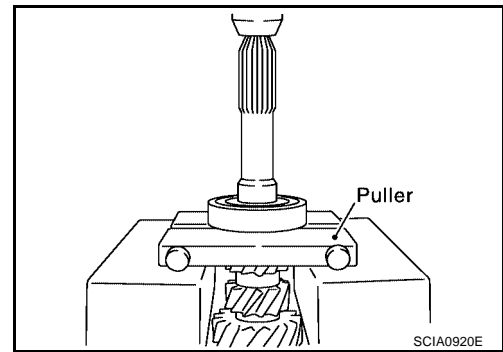

INSPECTION AFTER DISASSEMBLY

Input Shaft and Gears

Check parts for conditions listed below. If necessary, replace them with new ones.

- Damage, peeling, dent, uneven wear, bending of shaft.
- Excessive wear, damage, peeling of gears.

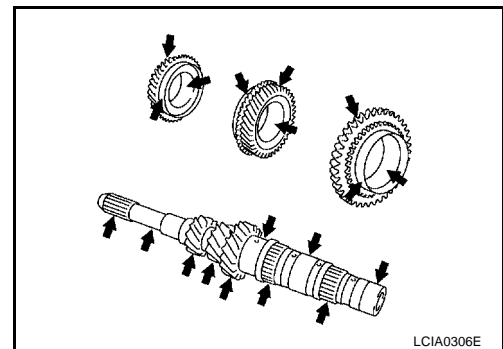

Synchronizer

Check parts for conditions listed below. If necessary, replace them with new ones.

- Damage and excessive wear of contact surfaces of coupling sleeve, synchronizer hub, and shifting insert
- Coupling sleeve and synchronizer hub must move smoothly.

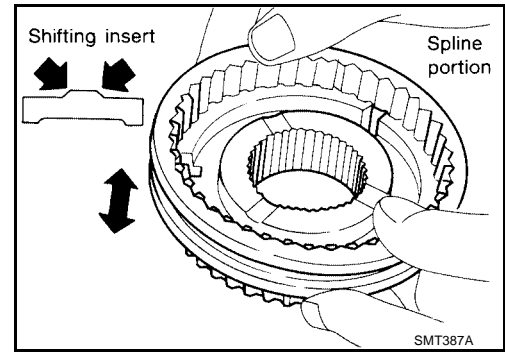

- If any crack, damage, or excessive wear is found on cam face of baulk ring or working face of insert, replace it.

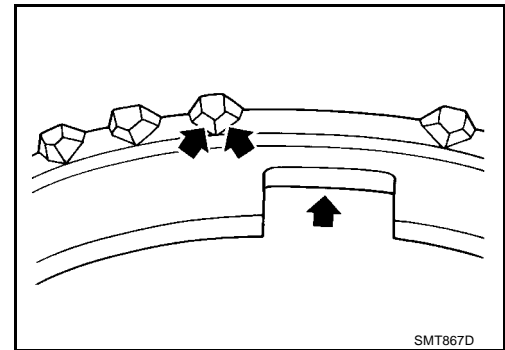

Baulk Ring Clearance

Check parts for conditions listed below. If necessary, replace them with new ones.

- Press baulk ring against cone, and measure clearance between baulk ring and cone. If measurement is below limit, replace it with a new one.

Baulk ring clearance

Standard

3rd and 4th : 0.9 - 1.45 mm (0.035 - 0.0571 in)

5th : 0.95 - 1.4 mm (0.0374 - 0.055 in)

Limit value : 0.7 mm (0.028 in)

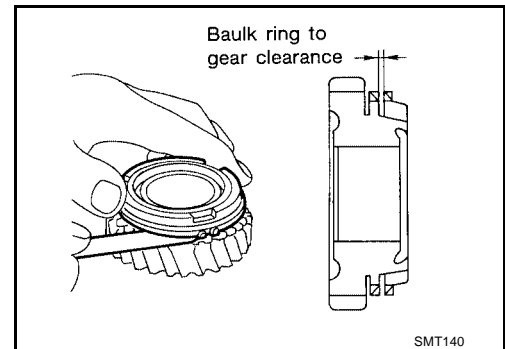

Bearing

Check parts for conditions listed below. If necessary, replace them with new ones.

- Damage and rough rotation of bearing

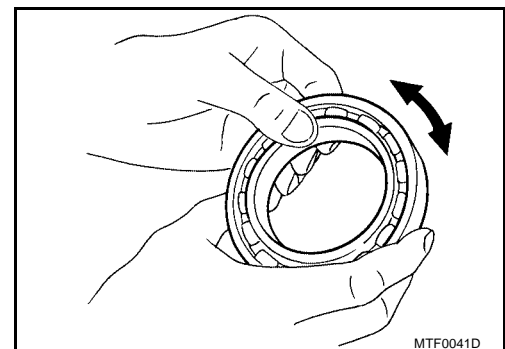

ASSEMBLY

1. Install 3rd needle bearing.
2. Install 3rd input gear and 3rd baulk ring.

A
B
MT
D
E
F
G
H
I
J
K
L
M

INPUT SHAFT AND GEARS

[RS5F51A]

3. Install spread spring, shifting insert and new 3rd-4th synchronizer hub onto 3rd-4th coupling sleeve.

CAUTION:

- Install with orientation of synchronizer hub as shown.
- Do not reuse 3rd-4th synchronizer hub.

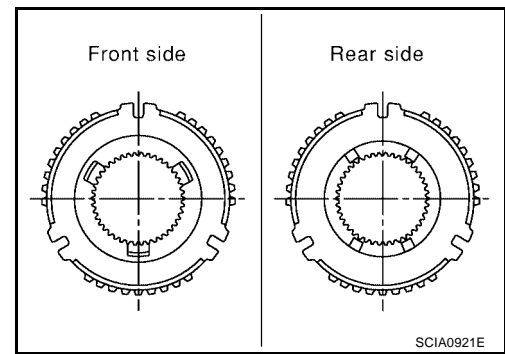

- Install with orientation of coupling sleeve as shown.

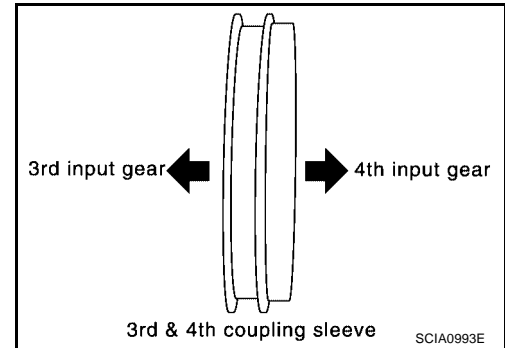

- Do not to hook the ends of the two spread springs (front and back have two each) on the same shifting insert as shown.

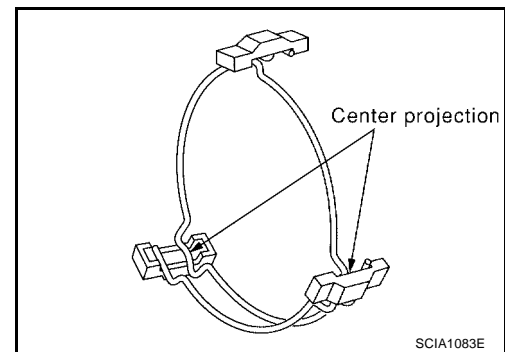

4. Install 3rd-4th synchronizer hub assembly using Tool as shown.

CAUTION:

Align the grooves of the shifting insert and 3rd baulk ring.

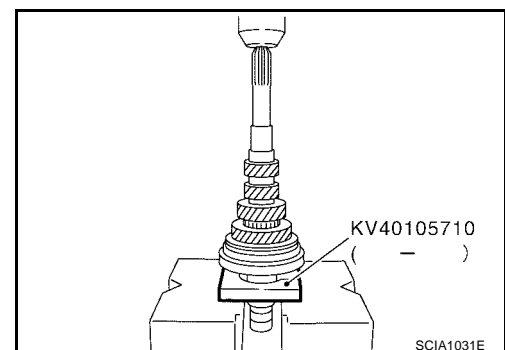

5. Install 4th bushing using Tool as shown.
6. Install 4th baulk ring.
7. Install 4th input gear and 4th needle bearing.

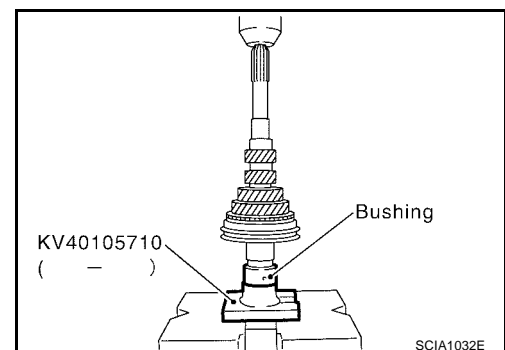

INPUT SHAFT AND GEARS

[RS5F51A]

8. Select thrust washer so that dimension "C2" satisfies standard below. Then install it onto input shaft.

Standard for dimension "C2" : 154.7 - 154.8 mm (6.091 - 6.094 in)

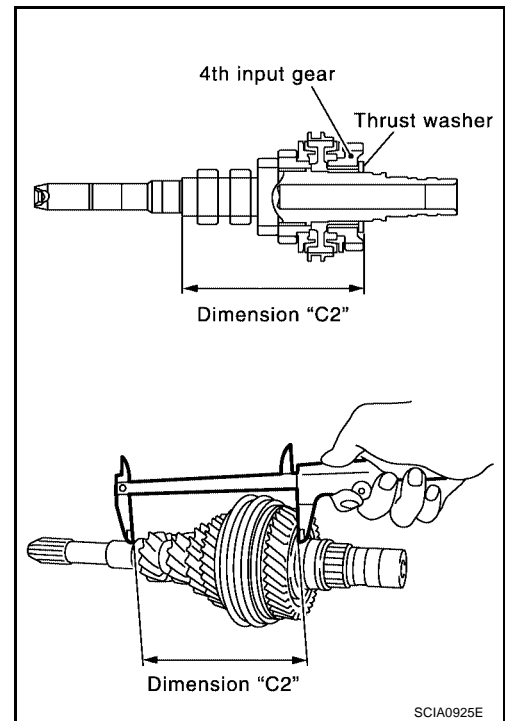

CAUTION:
Only one thrust washer can be selected.

Thrust Washer

Thickness	Part number	Thickness	Part number
3.84 mm (0.1512 in)	32347 8H500	4.02 mm (0.1583 in)	32347 8H503
3.90 mm (0.1535 in)	32347 8H501	4.08 mm (0.1606 in)	32347 8H504
3.96 mm (0.1559 in)	32347 8H502	4.14 mm (0.1630 in)	32347 8H505

9. Install 5th bushing using Tool as shown.
10. Install 5th needle bearing and 5th input gear.
11. Install 5th baulk ring.

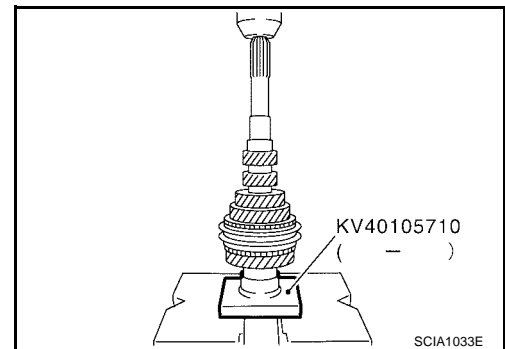

12. Install spread spring, shifting insert and 5th synchronizer hub onto 5th coupling sleeve.

CAUTION:
● Install with orientation of synchronizer hub and shifting insert as shown.

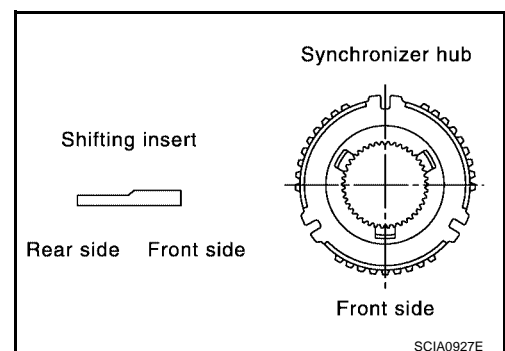

INPUT SHAFT AND GEARS

[RS5F51A]

- Install with orientation of coupling sleeve as shown.

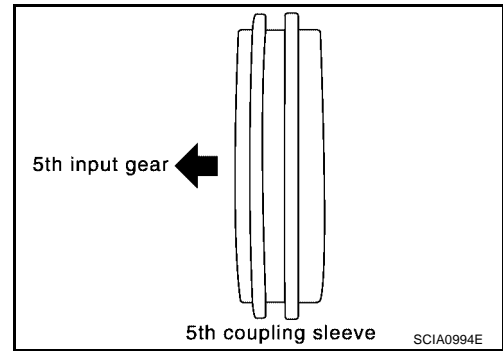

- Do not hook the ends of the two spread springs (front and back has two each) on the same shifting insert as shown.

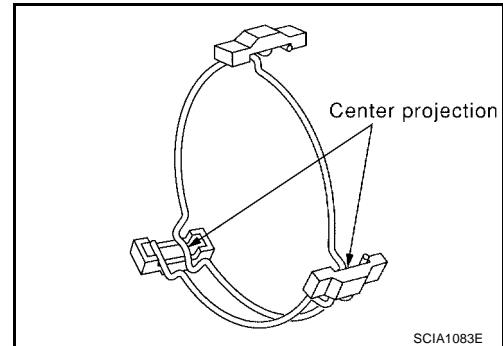

13. Install 5th synchronizer hub assembly using Tool as shown.

CAUTION:
Align the grooves of 5th shifting insert and 5th baulk ring.

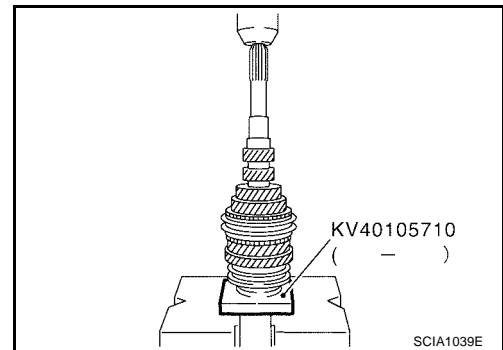

14. Install 5th stopper and then input shaft bearing spacer using Tool as shown.

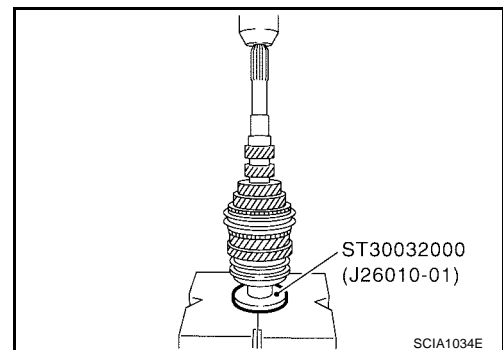

15. Install snap ring onto input shaft, and check that end play (gap between snap ring and groove) of input shaft bearing spacer is within the standard value.

End play standard value : 0 - 0.1 mm (0 - 0.004 in)

- If the measurement is outside the standard value, select the required snap ring size to correct the end play.

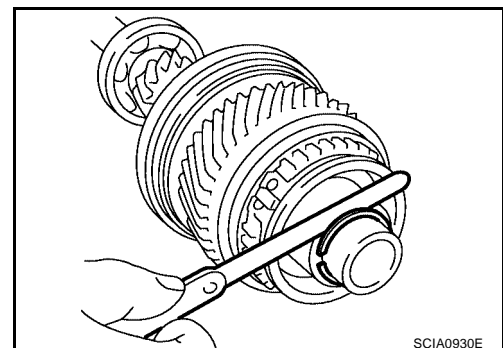

INPUT SHAFT AND GEARS

[RS5F51A]

Snap Rings

Thickness	Part number	Thickness	Part number
1.71 mm (0.0673 in)	32204 8H510	2.01 mm (0.0791 in)	32204 8H516
1.76 mm (0.0693 in)	32204 8H511	2.06 mm (0.0811 in)	32204 8H517
1.81 mm (0.0713 in)	32204 8H512	2.11 mm (0.0831 in)	32204 8H518
1.86 mm (0.0732 in)	32204 8H513	2.16 mm (0.0850 in)	32204 8H519
1.91 mm (0.0752 in)	32204 8H514	2.21 mm (0.0871 in)	32204 8H520
1.96 mm (0.0772 in)	32204 8H515	2.26 mm (0.0890 in)	32204 8H521

16. Install the input shaft rear bearing using Tool as shown.

CAUTION:

Install input shaft rear bearing with its brown surface facing the input gear side.

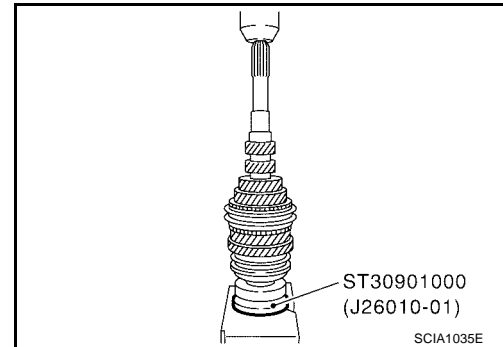

17. Install the input shaft front bearing using Tool as shown.

18. Install the oil channel onto input shaft.

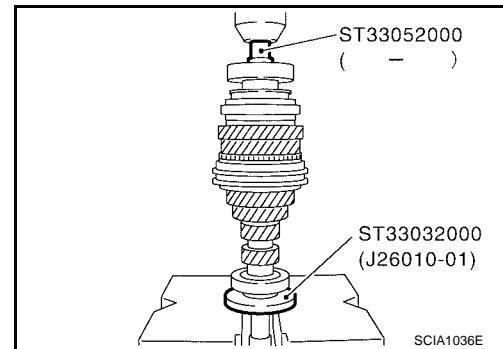

19. Check the end play of 3rd, 4th, and 5th input gears.

End play standard value

3rd gear : 0.18 - 0.31 mm (0.0071 - 0.0122 in)

4th gear : 0.20 - 0.30 mm (0.0079 - 0.0118 in)

5th gear : 0.06 - 0.16 mm (0.0024 - 0.0063 in)

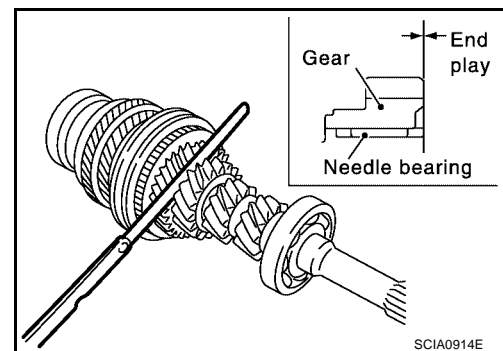

MAINSHAFT AND GEARS

Disassembly and Assembly

DISASSEMBLY

1. Before disassembling, measure the end play of 1st and 2nd main gears.

End play standard value

1st gear : 0.20 - 0.30 mm (0.0079 - 0.0118 in)

2nd gear : 0.06 - 0.16 mm (0.0024 - 0.0063 in)

CAUTION:

If the measurement is outside the standard value, disassemble to check the contact surfaces of the gear, shaft, and hub. Adjust with the correct snap ring size at assembly.

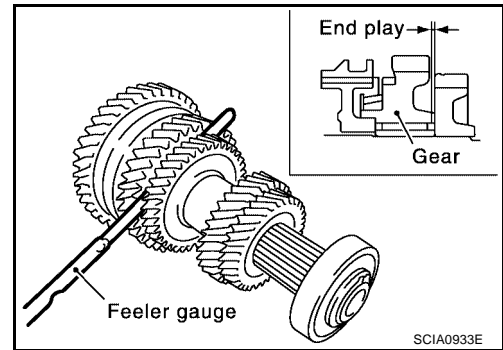

2. Remove the snap ring.
3. Remove the C-ring holder, and then mainshaft C-ring as shown.

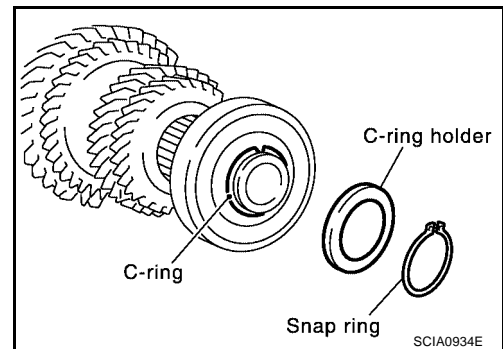

4. Remove the mainshaft rear bearing using Tool as shown.

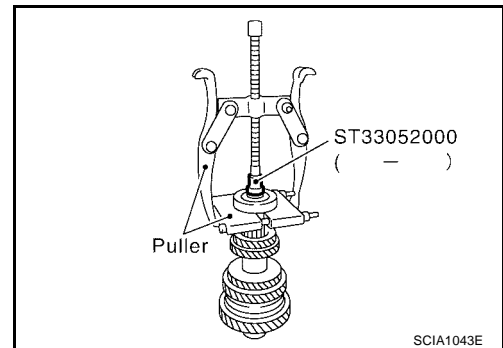

5. Remove the snap ring.

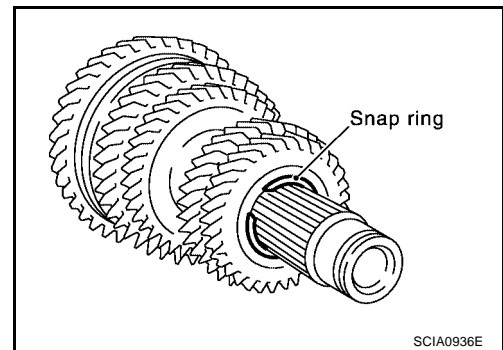

MAINSHAFT AND GEARS

[RS5F51A]

6. Remove 4th main gear and 5th main gear simultaneously using Tool as shown.
7. Remove adjusting shim.
8. Remove 3rd-4th mainshaft spacer.

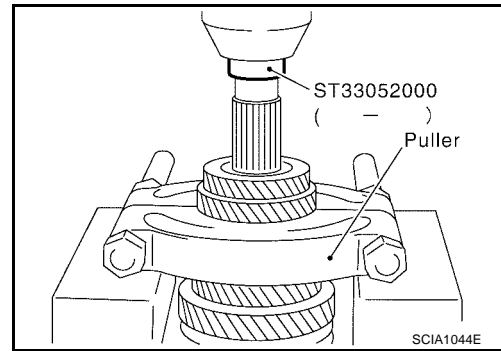

9. Remove 3rd main gear, 2nd main gear, 2nd needle bearing, 2nd bushing, 1st-2nd synchronizer hub assembly, 1st main gear, reverse main gear, 1st needle bearing, and 1st bushing simultaneously using Tool as shown.

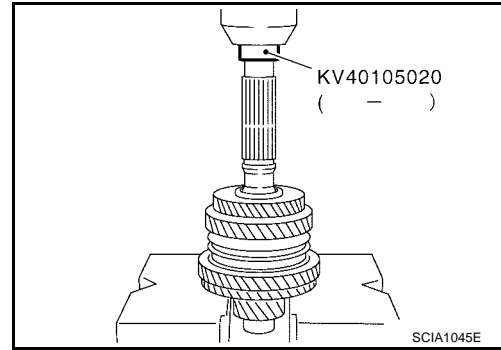

INSPECTION AFTER DISASSEMBLY

Mainshaft and Gears

Check parts listed. If necessary, replace them with new ones.

- Damage, peeling, dent, uneven wear, bending, and other non-standard conditions of the shaft.
- Excessive wear, damage, peeling, and other non-standard conditions of the gears.

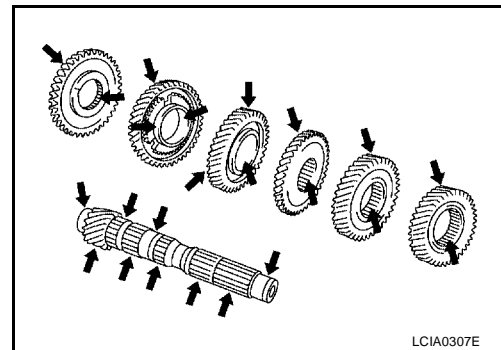

Synchronizer

Check parts listed. If necessary, replace them with new ones.

- Damage and unusual wear on contact surfaces of coupling sleeve, synchronizer hub, and shifting insert.
- Coupling sleeve and synchronizer hub must move smoothly.

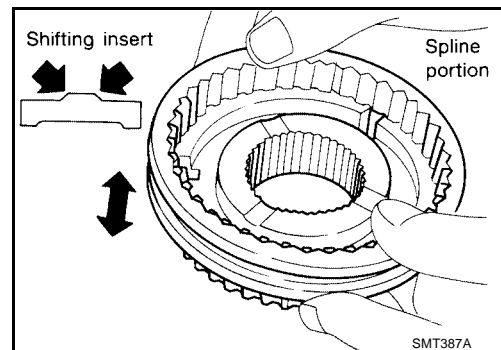

A
B
MT
D
E
F
G
H
I
J
K
L
M

- If any crack, damage, or excessive wear is found on cam face of baulk ring or working face of insert, replace it.

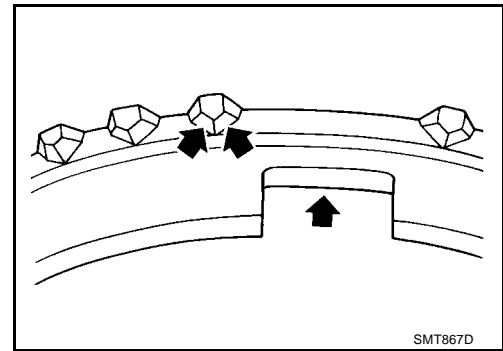

Baulk Ring Clearance

Checking the double cone synchronizer (1st and 2nd).

- Check the clearance of the outer baulk ring, synchronizer cone, and inner baulk ring of 1st and 2nd double cone synchronizers, following the procedure below.

NOTE:

The mean value is the middle value of a set of measurements between the highest and lowest values. It is calculated by adding the highest and lowest measured value and dividing their sum by two: $[(\text{high value}) + (\text{low value})] / 2 = \text{mean value}$.

CAUTION:

Outer baulk ring, synchronizer cone, and inner baulk ring act as a set to control the clearances "A" and "B". If the measurement exceeds the service limit value, replace all of them as a set.

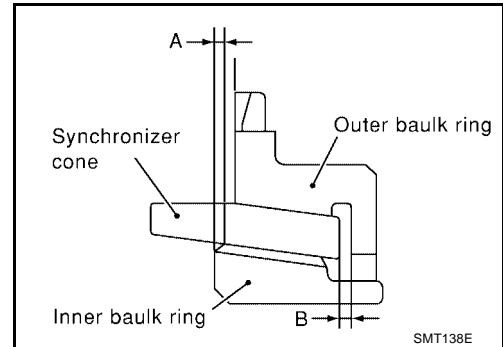

1. Using a dial gauge and Tool, measure clearance "A" at two or more points diagonally opposite, and calculate the mean value.

Clearance "A"

Standard : 0.6 - 0.8 mm (0.024 - 0.031 in)

Limit value : 0.2 mm (0.008 in) or less

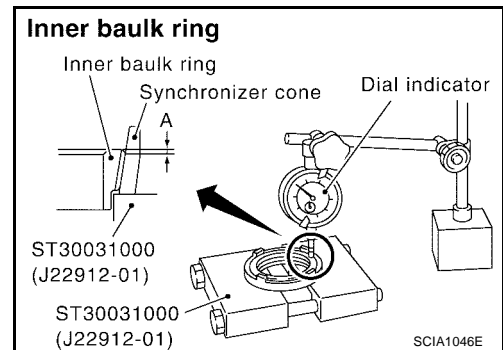

2. Using a feeler gauge, measure clearance "B" at two or more points diagonally opposite, and calculate the mean value.

Clearance "B"

Standard : 0.6 - 1.1 mm (0.024 - 0.043 in)

Limit value : 0.2 mm (0.008 in) or less

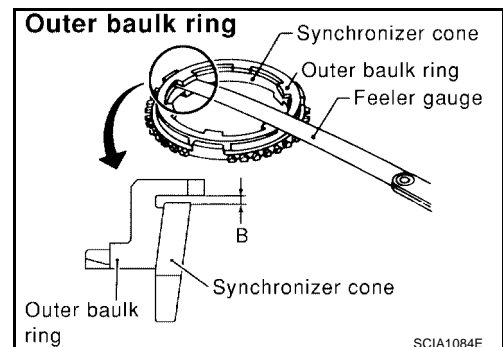

Bearing

Check items below. If necessary, replace them with new ones.

- Damage and rough rotation of bearing

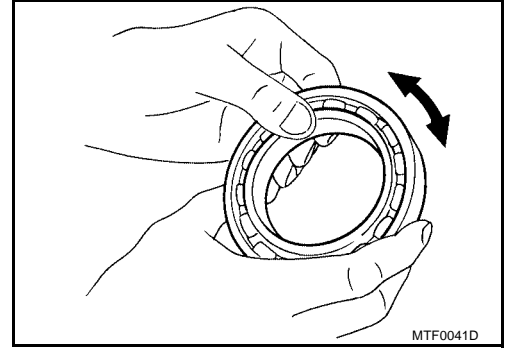

ASSEMBLY

1. Install reverse main gear using Tools as shown.

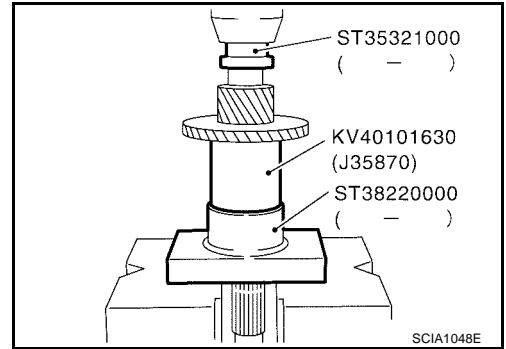

CAUTION:

Install the reverse main gear with the specified orientation as shown.

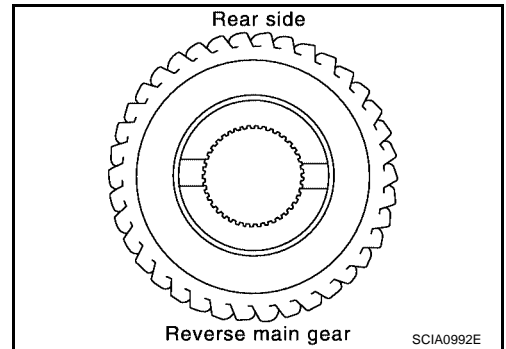

2. Install 1st bushing using Tools as shown.
3. Install needle bearing, and then 1st main gear.

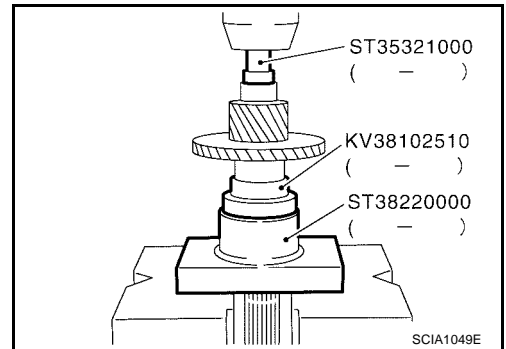

A
B
MT
D
E
F
G
H
I
J
K
L
M

MAINSHAFT AND GEARS

[RS5F51A]

4. Install spread spring, shifting insert and new 1st-2nd synchronizer hub onto 1st-2nd coupling sleeve.

CAUTION:

- Install with orientation of synchronizer hub as shown.
- Do not reuse the 1st-2nd synchronizer hub.

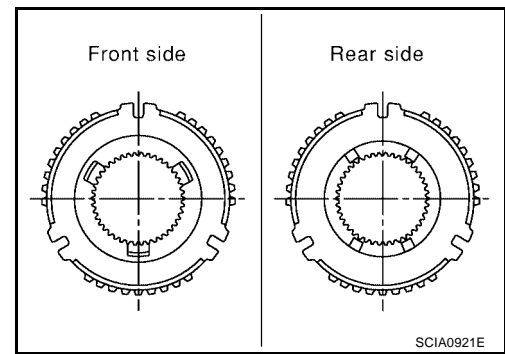

- Install with orientation of coupling sleeve as shown.

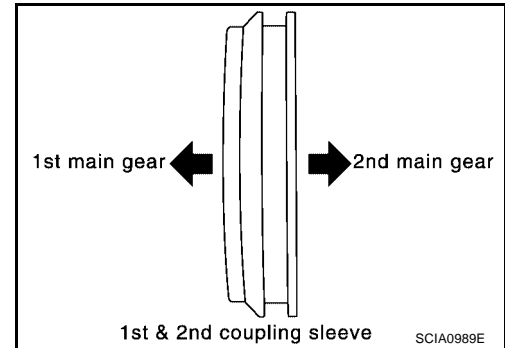

- Do not hook the ends of the two spread springs (front and back have two each) on same shifting insert as shown.

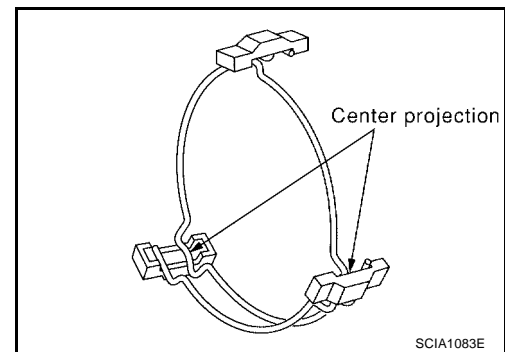

5. Install 1st gear synchronizer assembly onto mainshaft, and synchronizer hub assembly onto mainshaft using Tools as shown.

CAUTION:

- Outer baulk ring, synchronizer cone, and inner baulk ring on 2nd gear-side must have been removed.
- Install with orientation of coupling sleeve.

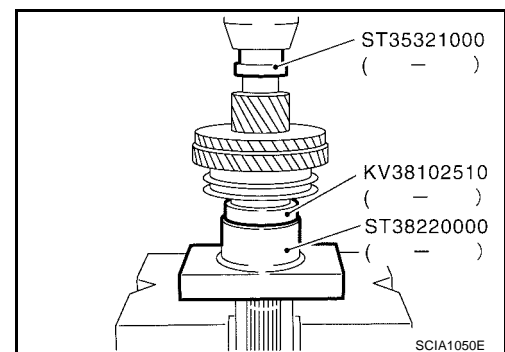

6. Install 2nd bushing using Tools as shown.
7. Install outer baulk ring, synchronizer cone, and inner baulk ring on 2nd gear-side.
8. Install 2nd needle bearing and 2nd gear.

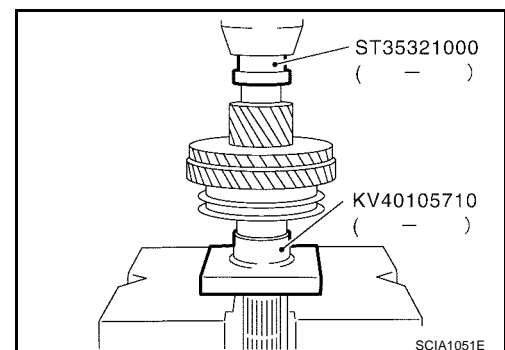

MAINSHAFT AND GEARS

[RS5F51A]

9. Install 3rd main gear using Tools as shown.

CAUTION:
Install with orientation of 3rd main gear as shown.

10. Install 3rd-4th mainshaft spacer.

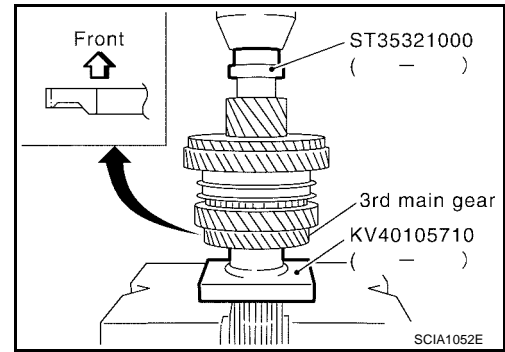

11. Select a suitable adjusting shim so that the dimension "C1" satisfies the standard value below, and install it onto the mainshaft as shown.

Standard for dimension "C1" : 173.85 - 173.95 mm (6.844 - 6.848 in)

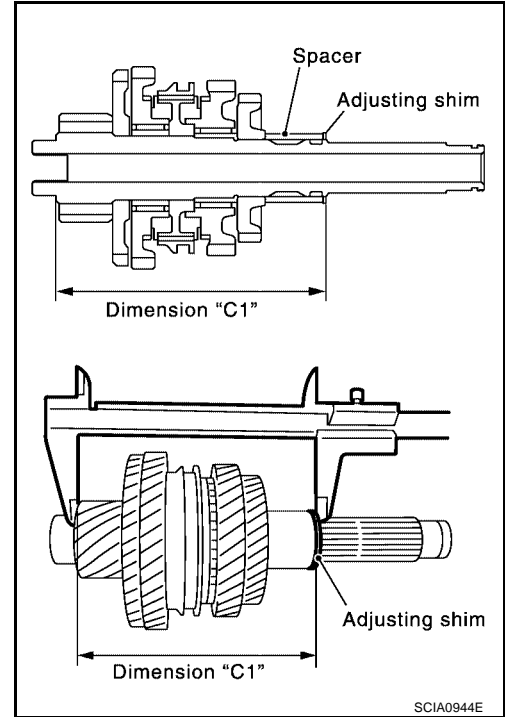

CAUTION:
Only 1 adjusting shim can be selected.

Adjusting Shims

Thickness	Part number	Thickness	Part number
0.52 mm (0.0205 in)	32238 8H500	0.84 mm (0.0331 in)	32238 8H504
0.60 mm (0.0236 in)	32238 8H501	0.92 mm (0.0362 in)	32238 8H505
0.68 mm (0.0268 in)	32238 8H502	1.00 mm (0.0394 in)	32238 8H506
0.76 mm (0.0299 in)	32238 8H503	1.08 mm (0.0425 in)	32238 8H507

12. Install 4th main gear using Tools as shown.

CAUTION:
Install with orientation of 4th main gear as shown.

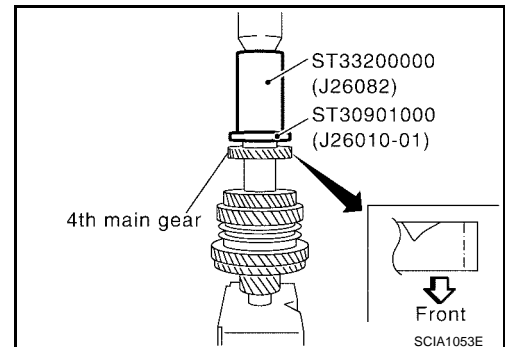

13. Install 5th main gear using Tools as shown.

CAUTION:
Install with orientation of 5th main gear as shown.

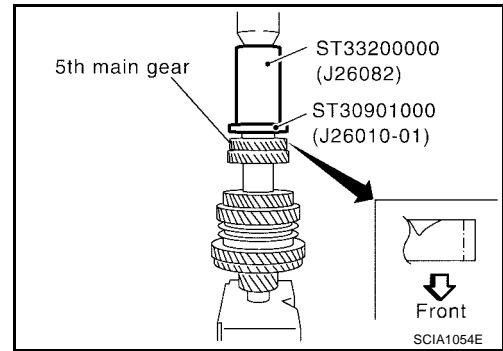

14. Install snap ring onto mainshaft, and check that end play of 5th main gear satisfies standard value as shown.

End play standard value : 0 - 0.1 mm (0 - 0.004 in)

- If measurement is outside the standard value, reselect the required size snap ring.

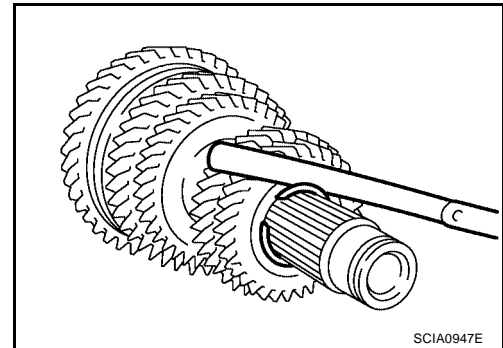

Snap Rings

Thickness	Part number	Thickness	Part number
1.85 mm (0.0728 in)	32204 8H500	2.05 mm (0.0807 in)	32204 8H504
1.90 mm (0.0748 in)	32204 8H501	2.10 mm (0.0827 in)	32204 8H505
1.95 mm (0.0768 in)	32204 8H502	2.15 mm (0.0846 in)	32204 8H506
2.00 mm (0.0787 in)	32204 8H503	2.20 mm (0.0866 in)	32204 8H507

15. Install mainshaft rear bearing using Tools as shown.

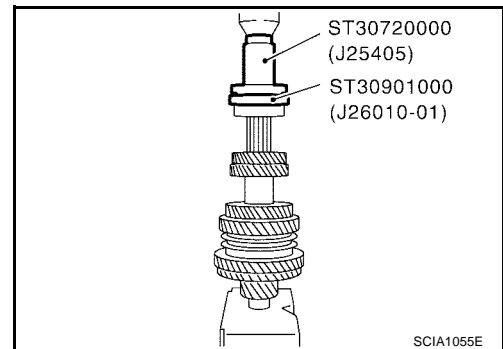

16. Install C-ring onto mainshaft, and check that end play of mainshaft rear bearing meets specification as shown.

End play standard value : 0 - 0.06 mm (0 - 0.0024 in)

- If measurement is outside the standard value, reselect the required size C-ring.

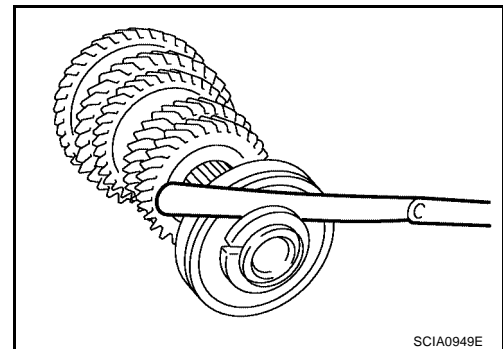

MAINSHAFT AND GEARS

[RS5F51A]

C-rings

Thickness	Part number	Thickness	Part number
2.535 mm (0.0866 in)	32348 8H800	2.835 mm (0.1116 in)	32348 8H810
2.565 mm (0.1010 in)	32348 8H801	2.865 mm (0.1128 in)	32348 8H811
2.595 mm (0.1022 in)	32348 8H802	2.895 mm (0.1140 in)	32348 8H812
2.625 mm (0.1033 in)	32348 8H803	2.925 mm (0.1152 in)	32348 8H813
2.655 mm (0.1045 in)	32348 8H804	2.955 mm (0.1163 in)	32348 8H814
2.685 mm (0.1057 in)	32348 8H805	2.985 mm (0.1175 in)	32348 8H815
2.715 mm (0.1069 in)	32348 8H806	3.015 mm (0.1187 in)	32348 8H816
2.745 mm (0.1081 in)	32348 8H807	3.045 mm (0.1199 in)	32348 8H817
2.775 mm (0.1093 in)	32348 8H808	3.075 mm (0.1211 in)	32348 8H818
2.805 mm (0.1104 in)	32348 8H809		

17. Fit C-ring holder, and install snap ring as shown.

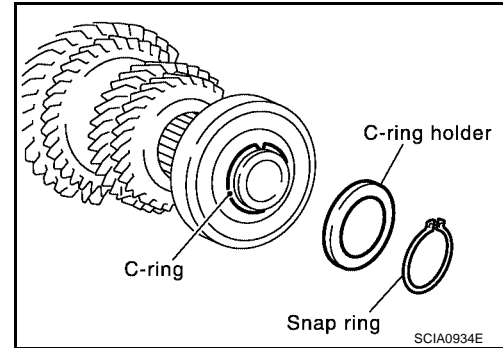

18. Check end play of 1st and 2nd main gears.

End play standard value

1st gear : 0.20 - 0.30 mm (0.0079 - 0.0118 in)

2nd gear : 0.06 - 0.16 mm (0.0024 - 0.0063 in)

REVERSE IDLER SHAFT AND GEARS

Disassembly and Assembly DISASSEMBLY

1. Remove reverse idler gear adjusting shim.
2. Remove reverse idler gear (rear), reverse coupling sleeve and insert spring simultaneously.
3. Remove reverse idler gear needle bearing.
4. Remove thrust needle bearing.
5. Remove reverse baulk ring.
6. Remove reverse idler gear (front).
7. Remove reverse idler gear needle bearing.
8. Remove thrust needle bearing.
9. Pull off locking pin from reverse idler shaft.

INSPECTION AFTER DISASSEMBLY

Reverse Idler Shaft and Gears

Check parts listed below. If necessary, replace them with new ones.

- Damage, peeling, dent, uneven wear, bending, and other non-standard conditions of the shaft.
- Excessive wear, damage, peeling, and other non-standard conditions of the gears.

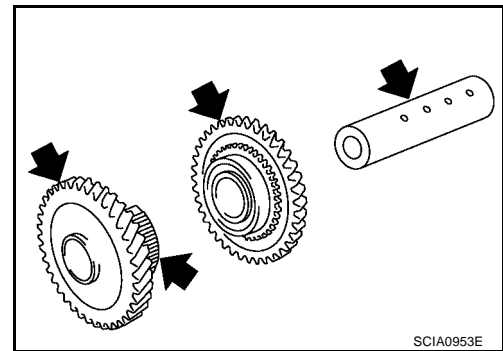

Synchronizer

Check parts listed below. If necessary, replace them with new ones.

- Damage and unusual wear on contact surfaces of coupling sleeve, synchronizer hub, and insert spring.
- Coupling sleeve and synchronizer hub must move smoothly.

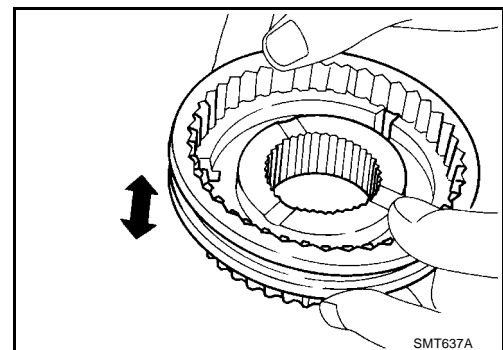

- If any crack, damage, or excessive wear is found on cam face of baulk ring or working face of insert, replace it.

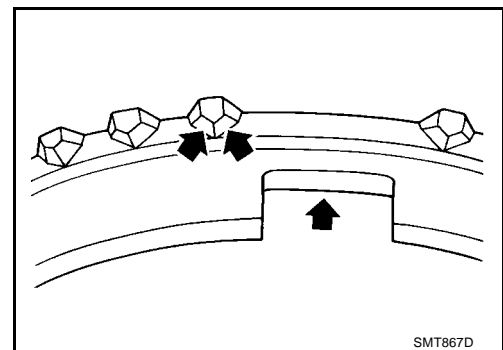

Baulk Ring Clearance

Press baulk ring against cone, and measure clearance between baulk ring and cone. If measurement is below limit value, replace it with a new one.

Clearance

Standard : 0.95 - 1.4 mm (0.0374 - 0.055 in)

Limit value : 0.7 mm (0.028 in)

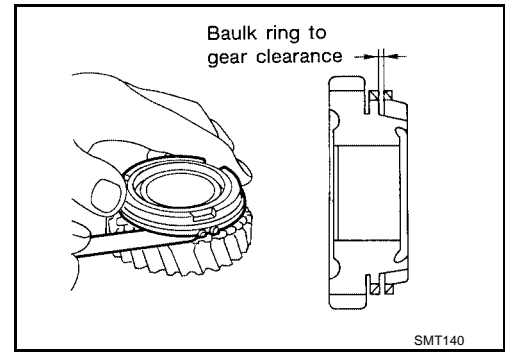

Bearing

Check parts listed below. If necessary, replace them with new ones.

- Damage and rough rotation of bearing.

ASSEMBLY

Assembly is in the reverse order of disassembly.

CAUTION:

- Install with orientation of insert spring as shown.

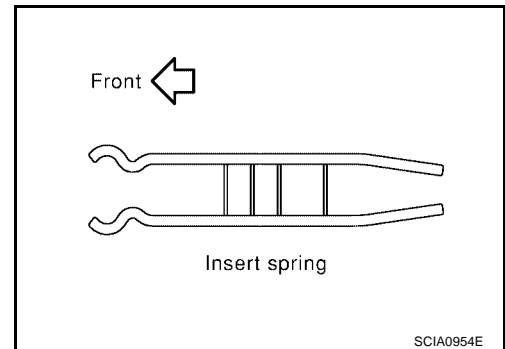

A
B
MT
D
E
F
G
H
I
J
K
L
M

FINAL DRIVE

PFP:38411

Disassembly and Assembly PRE-INSPECTION

ECS005US

1. Clean final drive assembly sufficiently to prevent side gear thrust washer, differential case, side gear, and other parts from sticking by gear oil.
2. Upright the differential case so that the side gear to be measured faces upward.
3. Place final drive adapter and dial indicator onto side gear using Tool as shown.

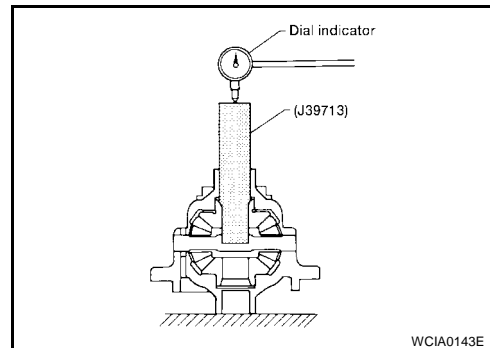

4. Move side gear up and down, and measure the clearance as shown.

Clearance between side gear and differential case : 0.1 - 0.2 mm (0.004 - 0.008 in)

CAUTION:

There must be no resistance and the gears must rotate freely.

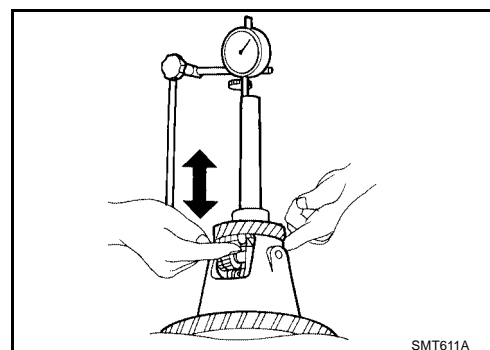

5. If the clearance measured is not within specification, adjust the clearance by changing the thrust washer thickness.
6. Turn the differential case upside down, and measure the clearance between the side gear and differential case on the other side to the same specifications, adjust using a thrust washer as necessary.

DISASSEMBLY

1. Remove the final gear bolts and then separate the final gear from the differential case.
2. Remove speedometer drive gear.
3. Using Tool and puller, remove differential side bearing (clutch housing side) as shown.

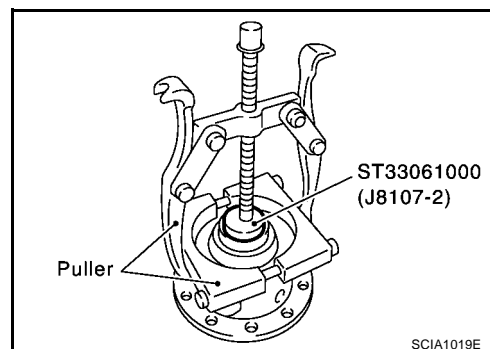

FINAL DRIVE

[RS5F51A]

- Using Tool and puller, remove differential side bearing (transaxle case side) as shown.

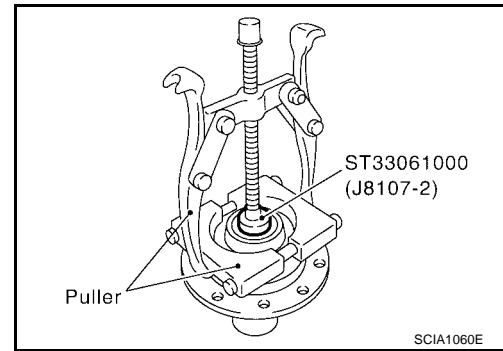

- Using a pin punch, pull out lock pin and pinion mate shaft as shown.

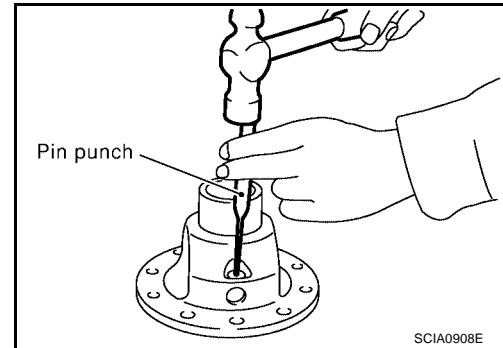

- Rotate pinion mate gears, and remove pinion mate gears, pinion mate thrust washers, side gears, and side gear thrust washers from differential case.

INSPECTION AFTER DISASSEMBLY

Gear, Washer, Shaft and Case

- Check side gears, side gear thrust washers, pinion mate shaft, pinion mate gears, pinion mate thrust washers and differential case as shown. If necessary, replace with new parts.

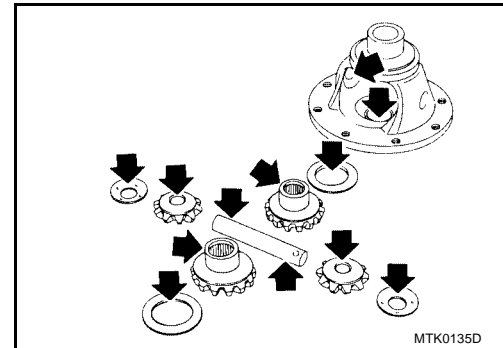

Bearing

- Check for bearing damage and rough rotation as shown. If necessary, replace with new parts.

CAUTION:

When replacing tapered roller bearing, replace outer and inner races as a set.

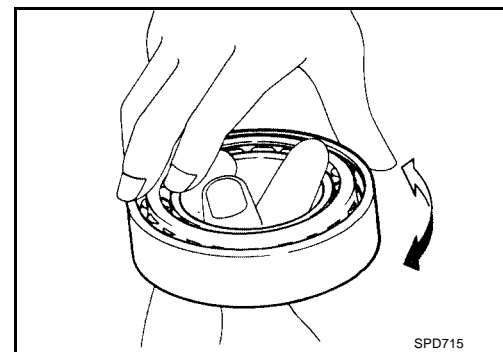

ASSEMBLY

- Apply gear oil to sliding area of differential case, each gear, and thrust washer.

A
B
MT
D
E
F
G
H
I
J
K
L
M

FINAL DRIVE

[RS5F51A]

2. Install side gear thrust washers and side gears into differential case as shown.

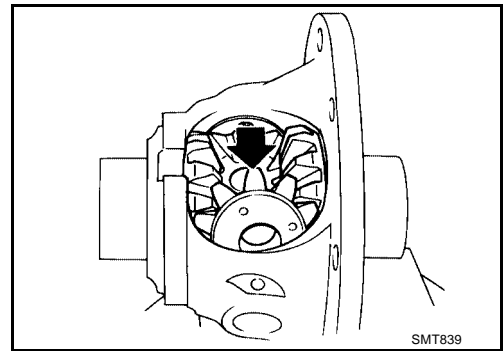

3. While rotating pinion mate thrust washers and pinion mate gears, and aligning them diagonally, install them into differential case.

4. Insert pinion mate shaft into differential case as shown.

CAUTION:

Be sure not to damage pinion mate thrust washers.

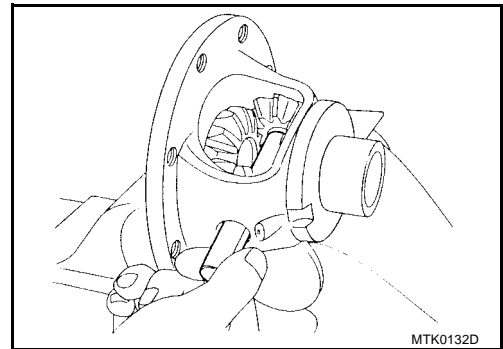

5. Measure end play of side gears, using the procedure below. Then select side gear thrust washer.

- a. Upright the differential case so that its side gear to be measured faces upward.
- b. Place final drive adapter and dial indicator onto side gears as shown.

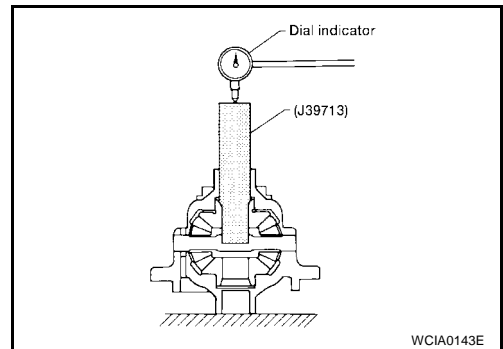

- c. Move side gears up and down to measure end play, and select thrust washer so that it meets specification.

End play standard value : 0.1 - 0.2 mm (0.004 - 0.008 in)

CAUTION:

- There must be no resistance and the gears must rotate freely.
- Place differential case upside down. Measure the end play for opposite side-gears using the same procedure.
- Only one thrust washer can be selected.

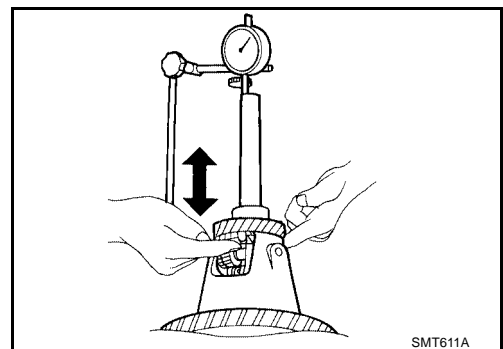

Thrust washers

Thickness	Part number
0.75 mm (0.0295 in)	38424 81X00
0.80 mm (0.0315 in)	38424 81X01
0.85 mm (0.0335 in)	38424 81X02
0.90 mm (0.0354 in)	38424 81X03
0.95 mm (0.0374 in)	38424 81X04

FINAL DRIVE

[RS5F51A]

6. Drive a new lock pin into the pinion mate shaft using a suitable tool as shown.

CAUTION:

Do not reuse the lock pin.

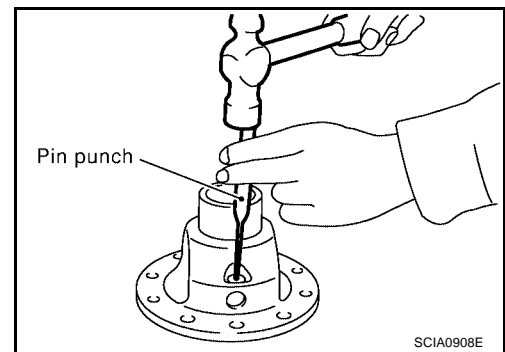

7. Install differential side bearing (transaxle case side) using Tool as shown.

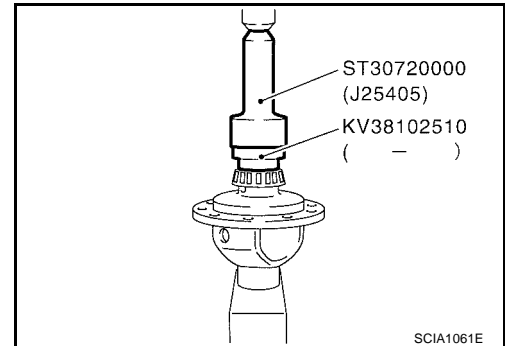

8. Align and install speedometer drive gear onto differential case as shown.

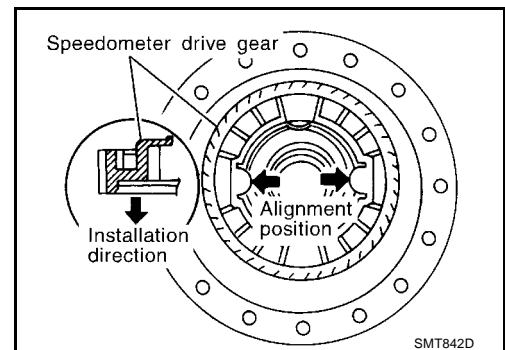

9. Install differential side bearing (clutch housing side) using Tools as shown.

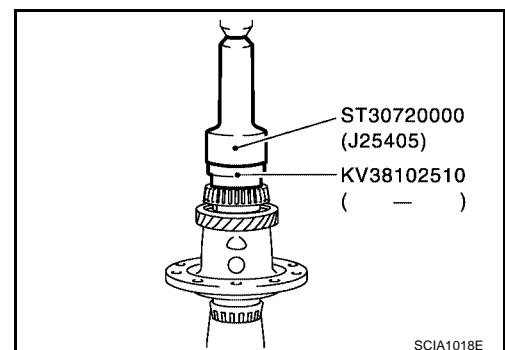

10. Install the final gear into the differential case, and tighten the final gear bolts to specification.

Final gear bolts : Refer to [MT-88, "FINAL DRIVE COMPONENTS"](#) .

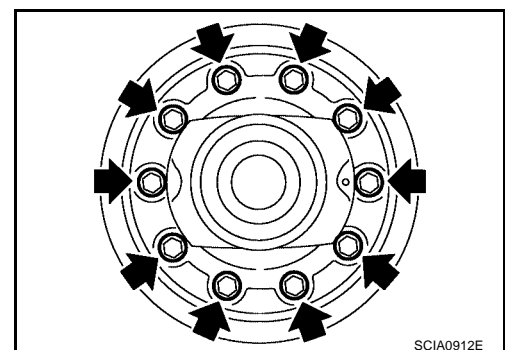

A
B
MT
D
E
F
G
H
I
J
K
L
M

SHIFT CONTROL

Inspection

- Check the contact surfaces and sliding areas for wear, damage, and bending as shown. Replace any parts as necessary.

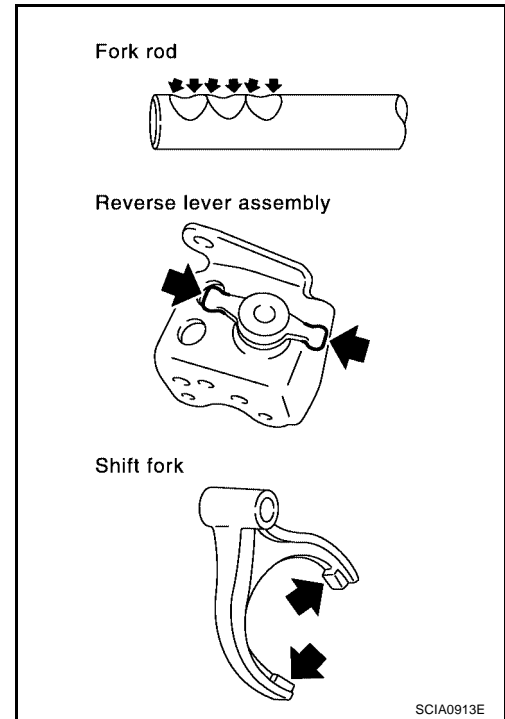

SHIFT FORK

- Check that the width of the shift fork hooks (sliding area with coupling sleeve) as shown, are within specification.

Item	One-side wear specification	Sliding width of new part
1st & 2nd	0.2 mm (0.008 in)	7.80 - 7.93 mm (0.3071 - 0.3122 in)
3rd & 4th	0.2 mm (0.008 in)	7.80 - 7.93 mm (0.3071 - 0.3122 in)
5th	0.2 mm (0.008 in)	6.10 - 6.23 mm (0.2402 - 0.2453 in)
Reverse	0.2 mm (0.008 in)	12.80 - 12.93 mm (0.5039 - 0.5091 in)

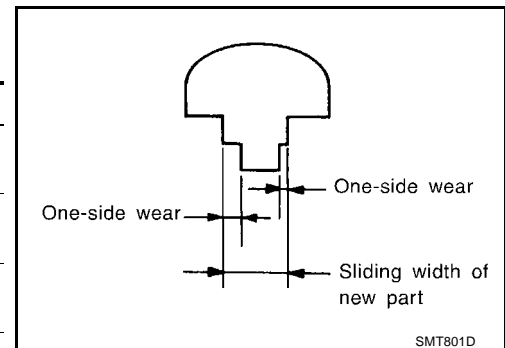

SERVICE DATA AND SPECIFICATIONS (SDS)

[RS5F51A]

SERVICE DATA AND SPECIFICATIONS (SDS)

PF0:00030

General Specifications TRANSAXLE

ECS005UU

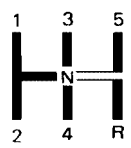
Engine		QR25DE	
Transaxle model		RS5F51A	
Model code number		8U006	
Number of speed		5	
Synchromesh type		Warner	
Shift pattern		 <p style="text-align: right;">SCIA0821E</p>	
Gear ratio	1st	3.153	
	2nd	1.842	
	3rd	1.258	
	4th	0.947	
	5th	0.772	
	Reverse	3.002	
Number of teeth	Input gear	1st	13
		2nd	19
		3rd	31
		4th	38
		5th	44
		Reverse	13
	Main gear	1st	41
		2nd	35
		3rd	39
		4th	36
		5th	34
		Reverse	38
	Reverse idler gear	Front	37
		Rear	38
Oil capacity ℓ (qt)		2.3 (2 3/8)	
Remarks	Reverse synchronizer	Installed	
	Double baulk ring type synchronizer	1st & 2rd synchronizer	

FINAL GEAR

Engine		QR25DE
Transaxle model		RS5F51A
Model code number		8U006
Final gear ratio		4.133
Number of teeth	Final gear/Pinion	62/15
	Side gear/Pinion mate gear	14/10

SERVICE DATA AND SPECIFICATIONS (SDS)

[RS5F51A]

Gear End Play

ECS005UV

Unit: mm (in)

Gear	End play
1st main gear	0.20 - 0.30 (0.0079 - 0.0118)
2nd main gear	0.06 - 0.16 (0.0024 - 0.0063)
3rd input gear	0.18 - 0.31 (0.0071 - 0.0122)
4th input gear	0.20 - 0.30 (0.0079 - 0.0118)
5th input gear	0.06 - 0.16 (0.0024 - 0.0063)

Clearance Between Baulk Ring and Gear 3RD, 4TH, 5TH & REVERSE BAULK RING

ECS005UW

Unit: mm (in)

Standard	Wear limit
3rd	0.9 - 1.45 (0.035 - 0.0571)
4th	0.9 - 1.45 (0.035 - 0.0571)
5th	0.95 - 1.4 (0.0374 - 0.055)
Reverse	0.95 - 1.4 (0.0374 - 0.055)

1ST AND 2ND DOUBLE BAULK RING

Unit: mm (in)

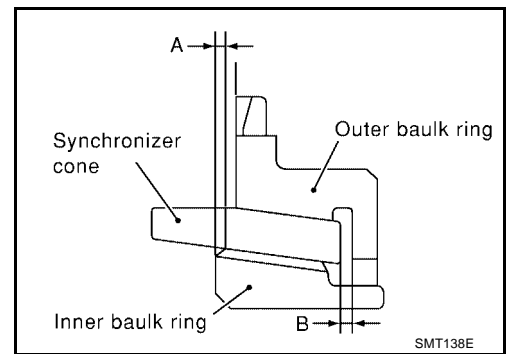

Dimension	Standard	Wear limit
A	0.6 - 0.8 (0.024 - 0.031)	0.2 (0.008)
B	1.6 - 1.1 (0.024 - 0.043)	0.2 (0.008)

Available Snap Rings INPUT SHAFT SPACER

ECS005UX

End play		0 - 0.1 mm (0 - 0.004 in)	
Thickness mm (in)	Part number*	Thickness mm (in)	Part number*
1.71 (0.0673)	32204 8H510	2.01 (0.0791)	32204 8H516
1.76 (0.0693)	32204 8H511	2.06 (0.0811)	32204 8H517
1.81 (0.0713)	32204 8H512	2.11 (0.0831)	32204 8H518
1.86 (0.0732)	32204 8H513	2.16 (0.0850)	32204 8H519
1.91 (0.0752)	32204 8H514	2.21 (0.0871)	32204 8H520
1.96 (0.0772)	32204 8H515	2.26 (0.0890)	32204 8H521

*: Always check with the Parts Department for the latest parts information.

5TH MAIN GEAR

End play		0 - 0.1 mm (0 - 0.004 in)	
Thickness mm (in)	Part number*	Thickness mm (in)	Part number*
1.85 (0.0728)	32204 8H500	2.05 (0.0807)	32204 8H504
1.90 (0.0748)	32204 8H501	2.10 (0.0827)	32204 8H505
1.95 (0.0768)	32204 8H502	2.15 (0.0846)	32204 8H506
2.00 (0.0787)	32204 8H503	2.20 (0.0866)	32204 8H507

SERVICE DATA AND SPECIFICATIONS (SDS)

[RS5F51A]

*: Always check with the Parts Department for the latest parts information.

Available C-rings MAINSHAFT C-RING

ECS005UY

End play		0 - 0.06 mm (0 - 0.0024 in)	
Thickness mm (in)	Part number*	Thickness mm (in)	Part number*
2.535 (0.0866)	32348 8H800	2.835 (0.1116)	32348 8H810
2.565 (0.1010)	32348 8H801	2.865 (0.1128)	32348 8H811
2.595 (0.1022)	32348 8H802	2.895 (0.1140)	32348 8H812
2.625 (0.1033)	32348 8H803	2.925 (0.1152)	32348 8H813
2.655 (0.1045)	32348 8H804	2.955 (0.1163)	32348 8H814
2.685 (0.1057)	32348 8H805	2.985 (0.1175)	32348 8H815
2.715 (0.1069)	32348 8H806	3.015 (0.1187)	32348 8H816
2.745 (0.1081)	32348 8H807	3.045 (0.1199)	32348 8H817
2.775 (0.1093)	32348 8H808	3.075 (0.1211)	32348 8H818
2.805 (0.1104)	32348 8H809		

*: Always check with the Parts Department for the latest parts information.

Available Thrust Washers INPUT SHAFT THRUST WASHER

ECS005UZ

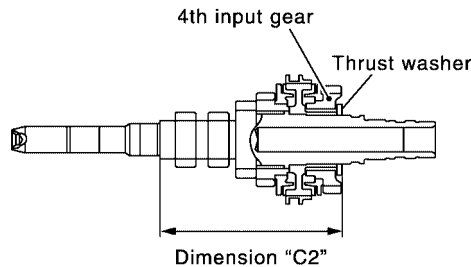

SCIA1008E

Standard length "C2"		154.7 - 154.8 mm (6.091 - 6.094in)	
Thickness mm (in)	Part number*	Thickness mm (in)	Part number*
3.84 (0.1512)	32347 8H500	4.02 (0.1583)	32347 8H503
3.90 (0.1535)	32347 8H501	4.08 (0.1606)	32347 8H504
3.96 (0.1559)	32347 8H502	4.14 (0.1630)	32347 8H505

*: Always check with the Parts Department for the latest parts information.

DIFFERENTIAL SIDE GEAR THRUST WASHER

Allowable clearance between side gear and differential case with washer	0.1 - 0.2 mm (0.004 - 0.008 in)
Thickness mm (in)	Part number*
0.75 (0.0295)	38424 81X00
0.80 (0.0315)	38424 81X01
0.85 (0.0335)	38424 81X02
0.90 (0.0354)	38424 81X03
0.95 (0.0374)	38424 81X04

*: Always check with the Parts Department for the latest parts information.

SERVICE DATA AND SPECIFICATIONS (SDS)

[RS5F51A]

ECS005V0

Available Adjusting Shims MAINSHAFT ADJUSTING SHIM

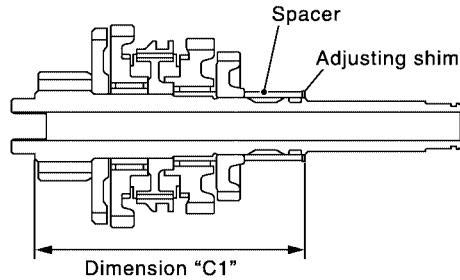

SCIA1009E

Standard length "C1"		173.85 - 173.95 mm (6.844 - 6.848in)	
Thickness mm (in)	Part number*	Thickness mm (in)	Part number*
0.52 (0.0205)	32238 8H500	0.84 (0.0331)	32238 8H504
0.60 (0.0236)	32238 8H501	0.92 (0.0362)	32238 8H505
0.68 (0.0268)	32238 8H502	1.00 (0.0394)	32238 8H506
0.76 (0.0299)	32238 8H503	1.08 (0.0425)	32238 8H507

*: Always check with the Parts Department for the latest parts information.

INPUT SHAFT REAR BEARING ADJUSTING SHIM

End play			0 - 0.06 mm (0 - 0.0024 in)		
Thickness mm (in)	Part number*	Thickness mm (in)	Part number*	Thickness mm (in)	Part number*
0.40 (0.0157)	32225 8H500	0.88 (0.0346)	32225 8H512	1.36 (0.0520)	32225 8H524
0.44 (0.0173)	32225 8H501	0.92 (0.0362)	32225 8H513	1.40 (0.0551)	32225 8H560
0.48 (0.0189)	32225 8H502	0.96 (0.0378)	32225 8H514	1.44 (0.0567)	32225 8H561
0.52 (0.0205)	32225 8H503	1.00 (0.0396)	32225 8H515	1.48 (0.0583)	32225 8H562
0.56 (0.0220)	32225 8H504	1.04 (0.0409)	32225 8H516	1.52 (0.0598)	32225 8H563
0.60 (0.0236)	32225 8H505	1.08 (0.0425)	32225 8H517	1.56 (0.0614)	32225 8H564
0.64 (0.0252)	32225 8H506	1.12 (0.0441)	32225 8H518	1.60 (0.0630)	32225 8H565
6.68 (0.0268)	32225 8H507	1.16 (0.0457)	32225 8H519	1.64 (0.0646)	32225 8H566
0.72 (0.0283)	32225 8H508	1.20 (0.0472)	32225 8H520	1.68 (0.0661)	32225 8H567
0.76 (0.0299)	32225 8H509	1.24 (0.0488)	32225 8H521	1.72 (0.0677)	32225 8H568
0.80 (0.0315)	32225 8H510	1.28 (0.0504)	32225 8H522		
0.84 (0.0331)	32225 8H511	1.32 (0.0520)	32225 8H523		

*: Always check with the Parts Department for the latest parts information.

MAINSHAFT REAR BEARING ADJUSTING SHIM

End play		0 - 0.06 mm (0 - 0.0024 in)	
Thickness mm (in)	Part number*	Thickness mm (in)	Part number*
0.44 (0.0173)	32238 8H510	0.80 (0.0315)	32238 8H519
0.48 (0.0189)	32238 8H511	0.84 (0.0331)	32238 8H520
0.52 (0.0205)	32238 8H512	0.88 (0.0346)	32238 8H521
0.56 (0.0220)	32238 8H513	0.92 (0.0362)	32238 8H522
0.60 (0.0236)	32238 8H514	0.96 (0.0378)	32238 8H523
0.64 (0.0252)	32238 8H515	1.00 (0.0396)	32238 8H524
0.68 (0.0268)	32238 8H516	1.04 (0.0409)	32238 8H560
0.72 (0.0283)	32238 8H517	1.08 (0.0425)	32238 8H561
0.76 (0.0299)	32238 8H518		

*: Always check with the Parts Department for the latest parts information.

SERVICE DATA AND SPECIFICATIONS (SDS)

[RS5F51A]

REVERSE IDLER GEAR ADJUSTING SHIM

End play		0.04 - 0.14 mm (0.0016 - 0.0055 in)	
Thickness mm (in)	Part number*	Thickness mm (in)	Part number*
1.76 (0.0693)	32237 8H500	2.24 (0.0882)	32237 8H506
1.84 (0.0724)	32237 8H501	2.32 (0.0913)	32237 8H507
1.92 (0.0756)	32237 8H502	2.40 (0.0945)	32237 8H508
2.00 (0.0787)	32237 8H503	2.48 (0.0976)	32237 8H509
2.08 (0.0819)	32237 8H504	2.56 (0.1008)	32237 8H510
2.16 (0.0850)	32237 8H505	2.64 (0.1039)	32237 8H511

*: Always check with the Parts Department for the latest parts information.

Available Shims

ECS005V1

— Differential Side Bearing Preload and Adjusting Shim —

BEARING PRELOAD

Differential side bearing preload: L*	0.15 - 0.21 mm (0.0059 - 0.0083)
---------------------------------------	----------------------------------

*: Install shims which are "deflection of differential case" + "L" in thickness.

DIFFERENTIAL SIDE BEARING ADJUSTING SHIM(S)

Thickness mm (in)	Part number*	Thickness mm (in)	Part number*
0.48 (0.0189)	31438 80X00	0.72 (0.0283)	31438 80X06
0.52 (0.0205)	31438 80X01	0.76 (0.0299)	31438 80X07
0.56 (0.0220)	31438 80X02	0.80 (0.0315)	31438 80X08
0.60 (0.0236)	31438 80X03	0.84 (0.0331)	31438 80X09
0.64 (0.0252)	31438 80X04	0.88 (0.0346)	31438 80X10
0.68 (0.0268)	31438 80X05	0.92 (0.0362)	31438 80X11

*: Always check with the Parts Department for the latest parts information.

PRECAUTIONS

PFP:00001

Caution

ECS005V2

- Do not reuse transaxle oil, once it has been drained.
- Check oil level, and drain and refill transaxle oil with the vehicle on level ground.
- During removal or installation, keep inside of transaxle clean of dust and dirt.
- Check for the correct installation orientation prior to removal or disassembly. If mating marks are required, be certain they do not interfere with the function of the parts they are applied to.
- In principle, tighten bolts or nuts gradually in several steps working diagonally and from inside to outside as applicable. If a tightening sequence is specified, follow it as specified.
- Be careful not to damage the sliding surfaces and mating surfaces of parts.

PREPARATION

[RS6F51H]

PF0:00002

ECS005V3

PREPARATION

Special Service Tools

The actual shapes of the Kent-Moore tools may differ from those of the special tools illustrated here.

Tool number (Kent-Moore No.) Tool name	Description
KV381054S0 (J34286) Puller	Side bearing outer race removal Mainshaft front bearing removal
ST35321000 (—) Drift	Input shaft oil seal installation Reverse main gear installation 1st bushing installation 1st-2nd synchronizer hub installation 2nd bushing installation 3rd main gear installation a: 49 mm (1.93 in) dia. b: 41 mm (1.61 in) dia.
ST30720000 (J25405) Drift	Differential oil seal installation Differential side bearing outer race installation Mainshaft rear bearing installation Differential side bearing installation a: 77 mm (3.03 in) dia. b: 55.5 mm (2.185 in) dia.
ST33200000 (J26082) Drift	Mainshaft front bearing installation 6th bushing installation 4th main gear installation 5th main gear installation 6th main gear installation a: 60 mm (2.36 in) dia. b: 44.5 mm (1.752 in) dia.
ST33061000 (J8107-2) Drift	Bore plug installation Differential side bearing removal a: 38 mm (1.50 in) dia. b: 28.5 mm (1.122 in) dia.
ST33052000 (—) Drift	Welch plug installation Input shaft rear bearing removal 5th bushing, thrust washer, 4th input gear, 4th gear bushing, 3rd-4th synchronizer hub and 3rd input gear removal Input shaft front bearing installation 6th input gear and 6th bushing removal Mainshaft rear bearing removal 4th main gear and 5th main gear removal 6th main gear removal a: 22 mm (0.87 in) dia. b: 28 mm (1.10 in) dia.

A

B

MT

D

E

F

G

H

I

J

K

L

M

PREPARATION

[RS6F51H]

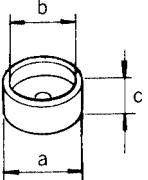
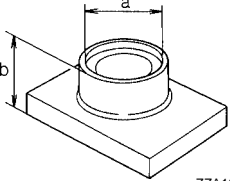
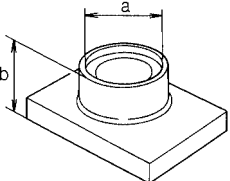
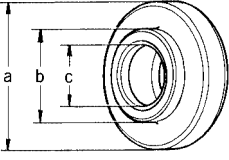
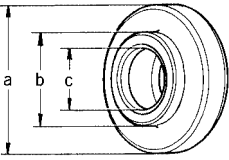
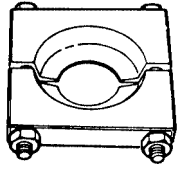
Tool number (Kent-Moore No.) Tool name	Description
KV40105020 (—) Drift	 <p>5th input gear and synchronizer hub removal 3rd main gear, 2nd main gear, 2nd bushing, 1st-2nd synchronizer hub, 1st main gear, re- verse main gear and 1st bushing removal a: 39.7 mm (1.563 in) dia. b: 35 mm (1.38 in) dia. c: 15 mm (0.59 in)</p> <p style="text-align: right;">ZZA1133D</p>
KV40105710 (—) Press stand	 <p>3rd-4th synchronizer hub installation 4th bushing installation 5th bushing installation 5th-6th synchronizer hub installation 2nd bushing installation 3rd main gear installation a: 46 mm (1.81 in) dia. b: 41 mm (1.61 in)</p> <p style="text-align: right;">ZZA1058D</p>
ST38220000 (—) Press stand	 <p>Reverse main gear installation 1st bushing installation 1st-2nd synchronizer hub installation a: 63 mm (2.48 in) dia. b: 65 mm (2.56 in)</p> <p style="text-align: right;">ZZA1058D</p>
ST30032000 (J26010-01) Drift	 <p>Input shaft front bearing installation a: 80 mm (3.15 in) dia. b: 38 mm (1.50 in) dia. c: 31 mm (1.22 in) dia.</p> <p style="text-align: right;">ZZA0978D</p>
ST30901000 (J26010-01) Drift	 <p>Input shaft rear bearing installation 4th main gear installation 5th main gear installation 6th main gear installation Mainshaft rear bearing installation a: 79 mm (3.11 in) dia. b: 45 mm (1.77 in) dia. c: 35.2 mm (1.386 in) dia.</p> <p style="text-align: right;">ZZA0978D</p>
ST30031000 (J22912-01) Puller	 <p>Measuring wear of 1st and 2nd baulk ring</p> <p style="text-align: right;">ZZA0537D</p>

PREPARATION

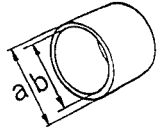
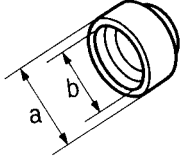

[RS6F51H]

Tool number (Kent-Moore No.) Tool name	Description
KV40101630 (J35870) Drift  ZZA1003D	Reverse main gear installation a: 68 mm (2.68 in) dia. b: 60 mm (2.36 in) dia.
KV38102510 (—) Drift  ZZA0838D	1st bushing installation 1st-2nd synchronizer hub installation Differential side bearing installation a: 71 mm (2.80 in) dia. b: 65 mm (2.56 in) dia.

A
B
MT

Commercial Service Tools

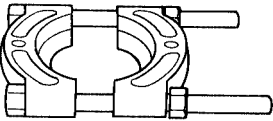
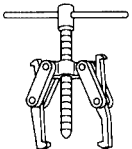
ECS005V4

Tool name	Description
Puller  ZZB0823D	Each bearing gear and bushing removal
Puller  NT077	Each bearing gear and bushing removal
Pin punch  ZZA0815D	Each retaining pin removal and installation Tip: 4.5 mm (0.177 in) dia.

F
G
H
I
J
K
L
M

NOISE, VIBRATION, AND HARSHNESS (NVH) TROUBLESHOOTING

[RS6F51H]

NOISE, VIBRATION, AND HARSHNESS (NVH) TROUBLESHOOTING

PF0:00003

NVH Troubleshooting Chart

ECS005V5

Use the chart below to help you find the cause of the symptom. The numbers indicate the order of the inspection. If necessary, repair or replace these parts.

Reference page		MT-76	MT-76	MT-76	MT-84			MT-140	MT-87		MT-85, MT-88			
Suspected parts (possible cause)		(oil level is low)	(wrong oil)	(oil level is high)	Gasket (damaged)	Oil seal (worn or damaged)	O-Ring (worn or damaged)	Control device and cable (worn)	Check plug return spring and check ball (worn or damaged)	Shift fork (worn)	Gear (worn or damaged)	Bearing (worn or damaged)	Baulk ring (worn or damaged)	Insert spring, shifting insert (damaged)
Symptom	Noise	1	2								3	3		
	Oil leakage		3	1	2	2	2							
	Hard to shift or will not shift		1	1				2					3	3
	Jumps out of gear							1	2	3	3			

DESCRIPTION

[RS6F51H]

DESCRIPTION

PF0:0000

Cross-sectional View

ECS005V6

RS6F51H

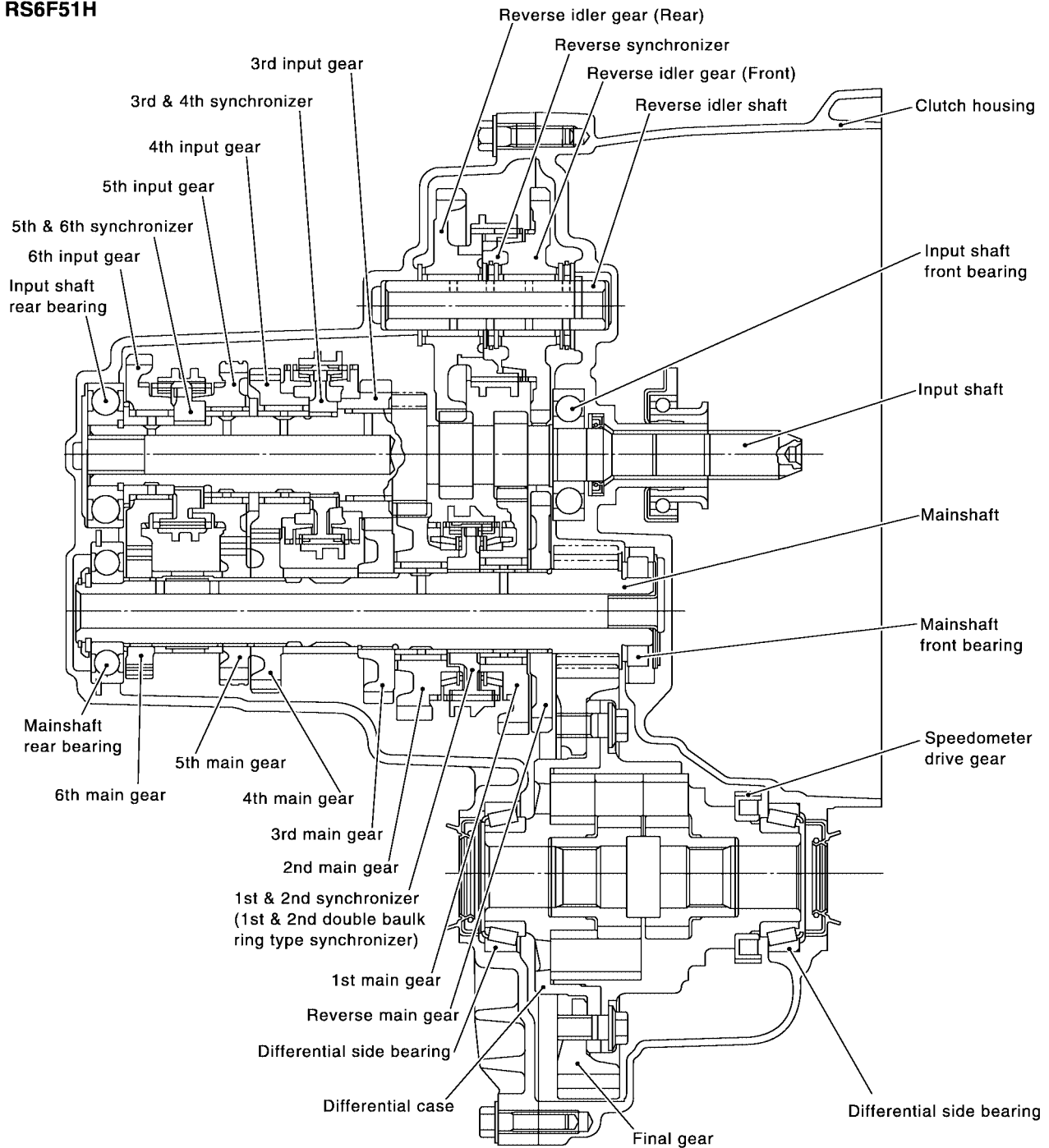

SCIA0999E

DOUBLE-CONE SYNCHRONIZER

Double-cone synchronizer is used for 1st and 2nd gears to reduce operating force of the shift lever as shown.

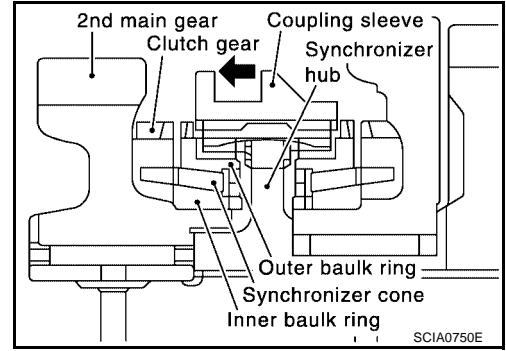

REVERSE GEAR

Description of reverse gear components is as shown.

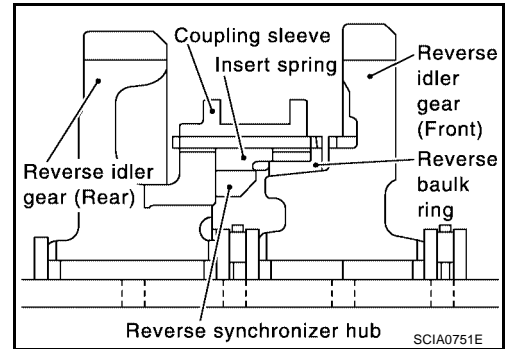

M/T OIL**Replacement
DRAINING**

1. Start the engine and let it run to warm up the transaxle oil.
2. Stop the engine. Remove drain plug and drain oil.
3. Set a new gasket on the drain plug and install it in transaxle body.

Drain plug : 30 - 39 N·m (3.1 - 4.0 kg·m, 23 - 28 ft·lb)

CAUTION:

Do not reuse gasket.

FILLING

1. Remove filler plug. Fill with new oil until oil level reaches the specified limit near filler plug mounting hole.

Oil grade : API GL-4

Capacity (reference) : Approximately 2.3 ℓ (2 3/8 qt)

2. After refilling oil, check oil level. Assemble a new gasket on to filler plug, then install it in transaxle body.

Filler plug : 30 - 39 N·m (3.1 - 4.0 kg·m, 23 - 28 ft·lb)

CAUTION:

Do not reuse gasket.

**Checking
OIL LEAKAGE AND OIL LEVEL**

- Check that oil is not leaking from transaxle.
 - Check oil level from filler plug mounting hole as shown.
- CAUTION:**
Never start engine while checking oil level.
- Set a new gasket on the filler plug and install it in transaxle body.

Filler plug : 30 - 39 N·m (3.1 - 4.0 kg·m, 23 - 28 ft·lb)

CAUTION:

Do not reuse gasket.

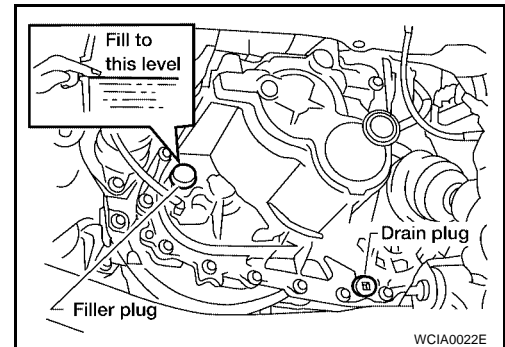

SIDE OIL SEAL

Removal and Installation

REMOVAL

1. Remove the drive shaft from the transaxle body. Refer to [FAX-14, "Removal"](#).
2. Remove oil seal with a slotted screwdriver.

CAUTION:

Be careful not to damage the case surface when removing the oil seal.

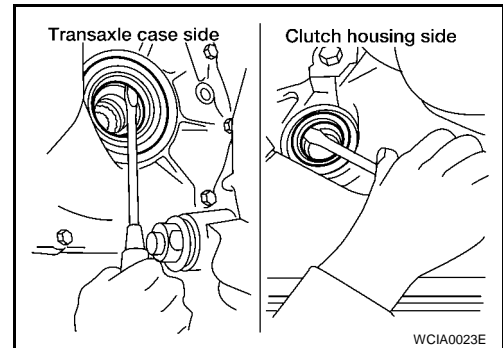

INSTALLATION

Installation is in the reverse order of removal.

- Using Tool (drift), drive the new oil seal straight until it protrudes from the case end equal to dimension "A" as shown.

Dimension "A" : Within 0.5 mm (0.02 in) or flush with the case.

CAUTION:

- Before installing oil seal, apply multi-purpose grease to oil seal lips.
- Oil seal is not reusable.

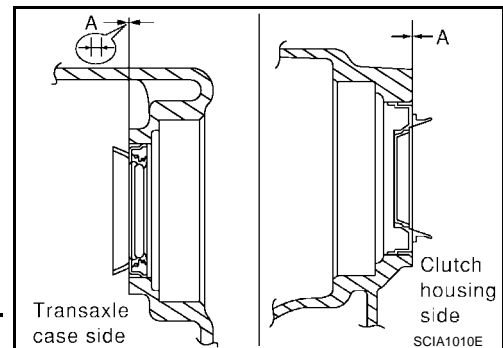

Drift to be used (special service tool)	ST30720000 (J25405)
-----------------------------------------	---------------------

- Check oil level after installation. Refer to [MT-137, "Checking"](#).

POSITION SWITCH

Checking

NOTE:

For removal and installation of the switches. Refer to [MT-145, "Component Parts"](#).

BACK-UP LAMP SWITCH

- Check continuity.

Gear position	Continuity
Reverse	Yes
Except reverse	No

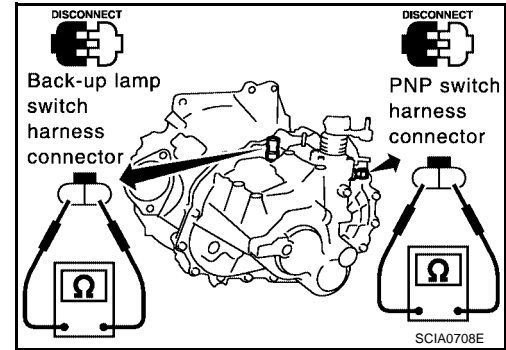

PARK/NEUTRAL POSITION SWITCH

- Check continuity.

Gear position	Continuity
Neutral	Yes
Except neutral	No

A
B
MT
D
E
F
G
H
I
J
K
L
M

CONTROL LINKAGE

PF3:34103

Removal and Installation of Control Device and Cable

ECS006H6

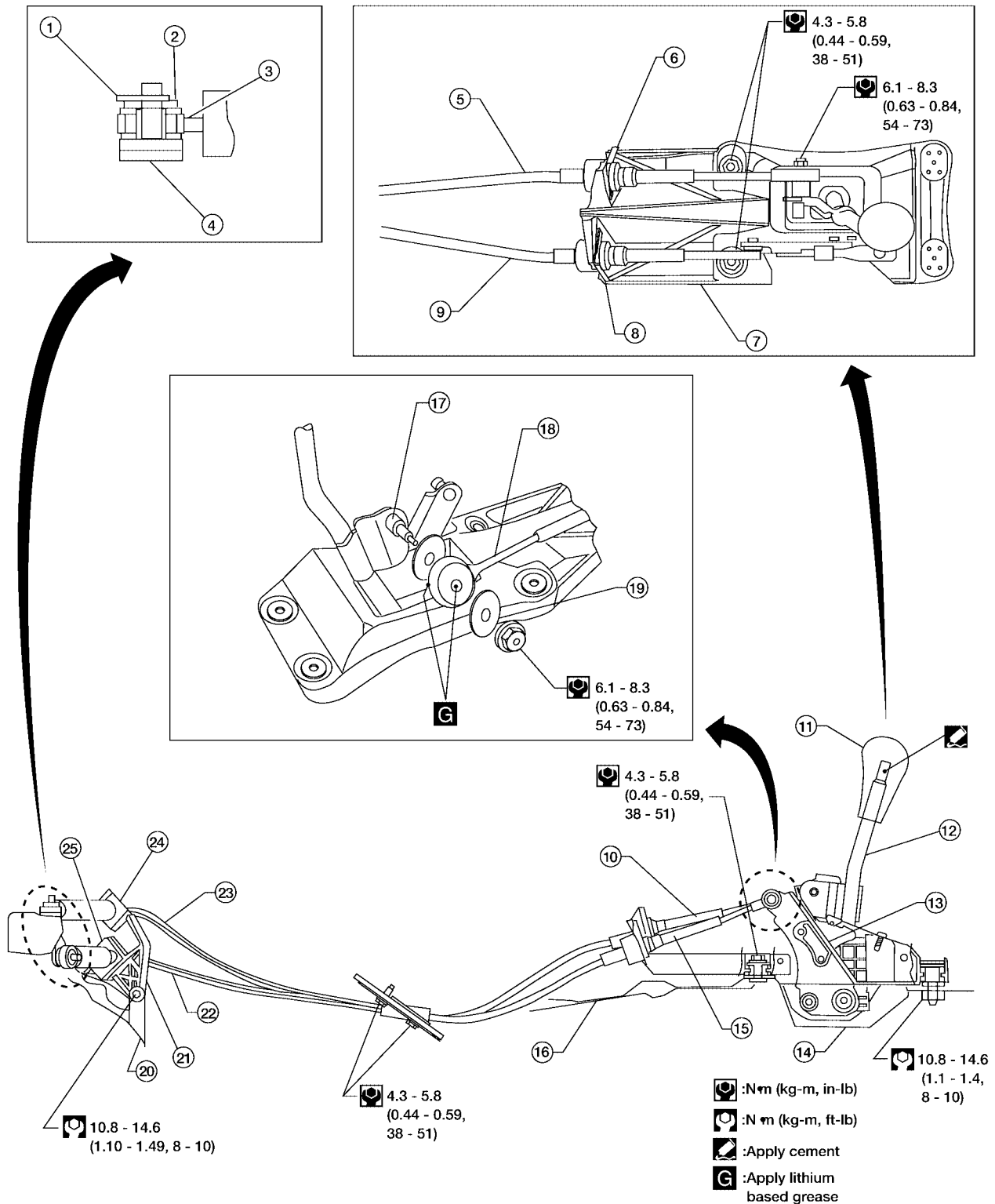

WCIA0136E

- 1. Snap pin
- 2. Washer
- 3. Cable
- 4. Manual lever
- 5. Shift cable
- 6. Lock plate
- 7. Control device assembly
- 8. Lock plate
- 9. Select cable
- 10. Shift cable
- 11. Control lever knob
- 12. Control lever

- | | | |
|-----------------------------|--------------------|----------------------------|
| 13. Control device assembly | 14. Cover | 15. Select cable |
| 16. Floor | 17. Pin | 18. Shift cable |
| 19. Washer | 20. Clutch housing | 21. Cable mounting bracket |
| 22. Select cable | 23. Shift cable | 24. Lock plate |
| 25. Lock plate | | |

CAUTION:

- Note that the select side lock plate for securing the control cable is different from the one on the shift side.
- After assembly, make sure selector lever automatically returns to Neutral when it is moved to 1st, 2nd, or Reverse.

Cable Adjustment

ECS0077W

NOTE:

After installation of the select cable, the cable must be adjusted for proper operation. This adjustment is performed before installing the interior console and shift boot.

1. Slide clip "B" from under clip "A" as shown.

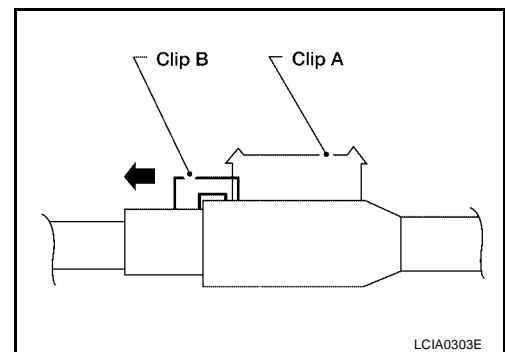

2. Shift the control lever to the neutral position.

CAUTION:

Do not move the control lever when adjusting the cables.

3. Push clip "A" into the cable end case until it snaps into place as shown.

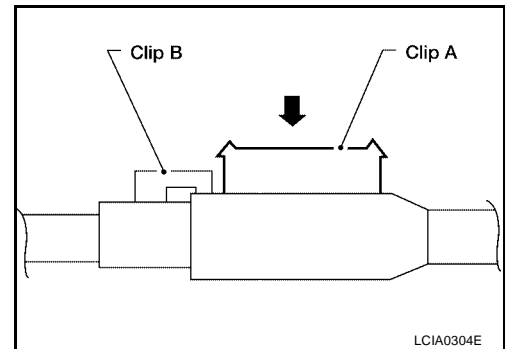

4. Slide clip "B" back over clip "A" until it snaps into place and holds clip "A" in place as shown.

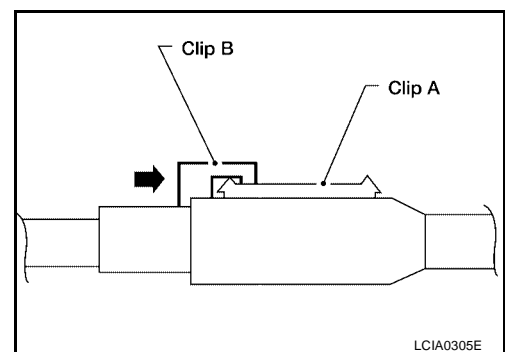

A
B
MT
D
E
F
G
H
I
J
K
L
M

AIR BREATHER HOSE Removal and Installation

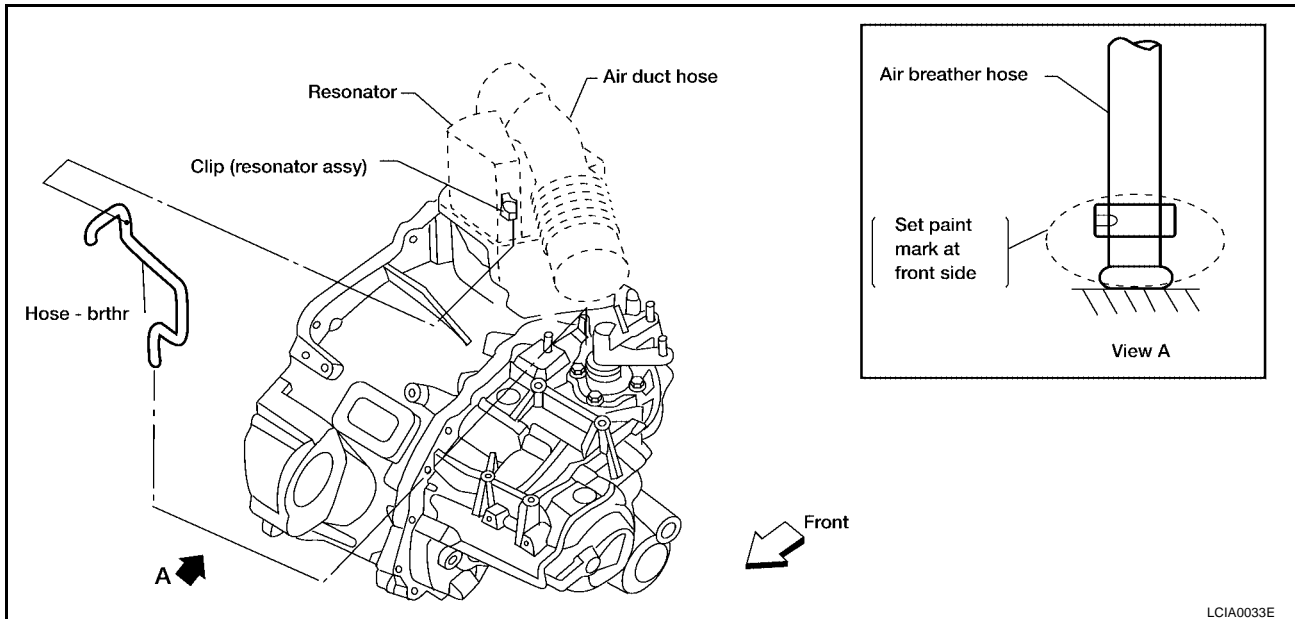

LCIA0033E

CAUTION:

- Make sure there are no pinched or restricted areas on the air breather hose caused by bending or winding when installing it.
- Insert the air breather hose into the transaxle tube until the overlap area reaches the spool.

TRANSAXLE ASSEMBLY

PFP:32010

Removal and Installation

ECS005VD

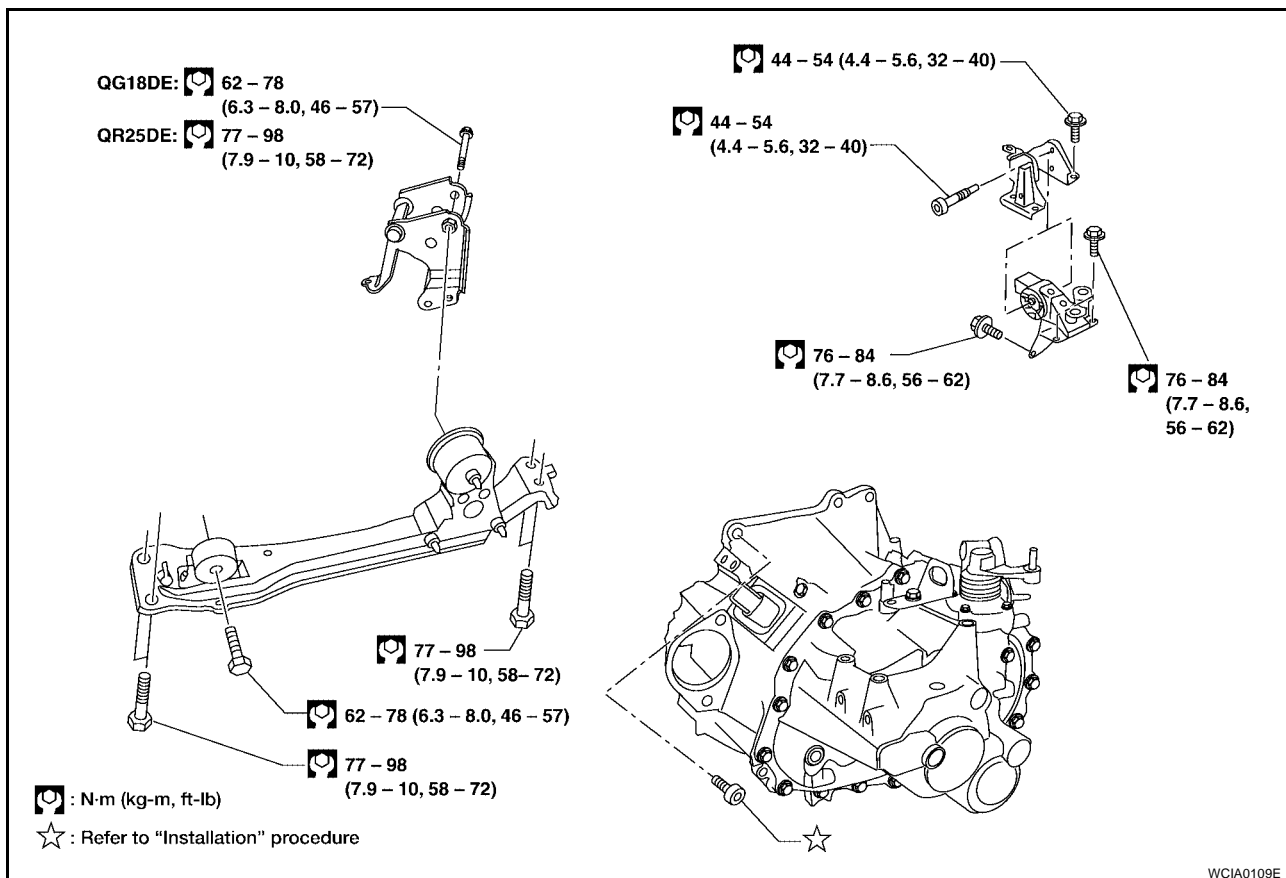

REMOVAL

1. Remove the air cleaner and air duct.
2. Remove the battery.
3. Remove the air breather hose. Refer to [MT-81, "Removal and Installation"](#) .
4. Remove the clutch operating cylinder.

CAUTION:
Do not depress the clutch pedal during the removal procedure.
5. Remove the engine under cover.
6. Disconnect the control cable from the transaxle. Refer to [MT-140, "Removal and Installation of Control Device and Cable"](#) .
7. Drain the gear oil from the transaxle. Refer to [MT-76, "Replacement"](#) .
8. Remove the connectors and harnesses for:
 - PNP switch
 - Speed sensor
 - Back-up lamp switch
 - Ground
9. Remove the exhaust front tube. Refer to [EX-3, "Removal and Installation"](#) .
10. Remove the drive shaft. Refer to [FAX-14, "Removal"](#) .
11. Remove the starter motor. Refer to [SC-20, "Removal and Installation"](#) .
12. Place a suitable jack under the transaxle.

CAUTION:
When setting the jack, be careful not to bring it into contact with the switches.
13. Remove the center member, engine insulator, and engine mount bracket.
14. Support the engine by placing a jack under the engine oil pan.

15. Remove the bolts that mount the engine to the transaxle.
16. Remove the transaxle from the vehicle as shown.

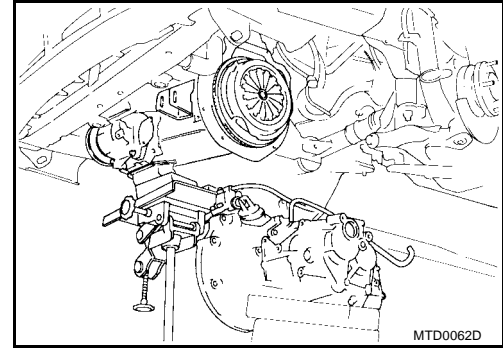

INSTALLATION

Installation is the reverse order of removal.

- When installing the transaxle to the engine, use the specified tightening torque in the numerical sequence as shown.

CAUTION:

When installing the transaxle, do not allow the transaxle input shaft to make contact with the clutch cover.

Bolt No.	1	2	3	4	5	6	7	8	9	10
" \varnothing " mm (in)	40	82	47	47	52	40	40	40	30	30
Tightening torque N·m (kg·m, ft·lb)	30 - 40 (3.1 - 4.1, 22 - 29)		70 - 80 (7.1 - 8.1, 52 - 59)			30 - 40 (3.1 - 4.1, 22 - 29)				

- After installation, check the transaxle oil level, and check for any leaks and any loose mechanisms.

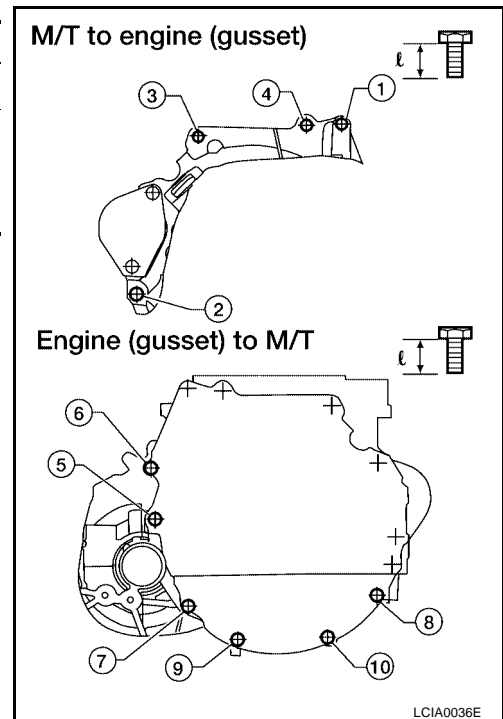

TRANSAXLE ASSEMBLY

[RS6F51H]

ECS005VE

Component Parts CASE AND HOUSING COMPONENTS

SEC. 321

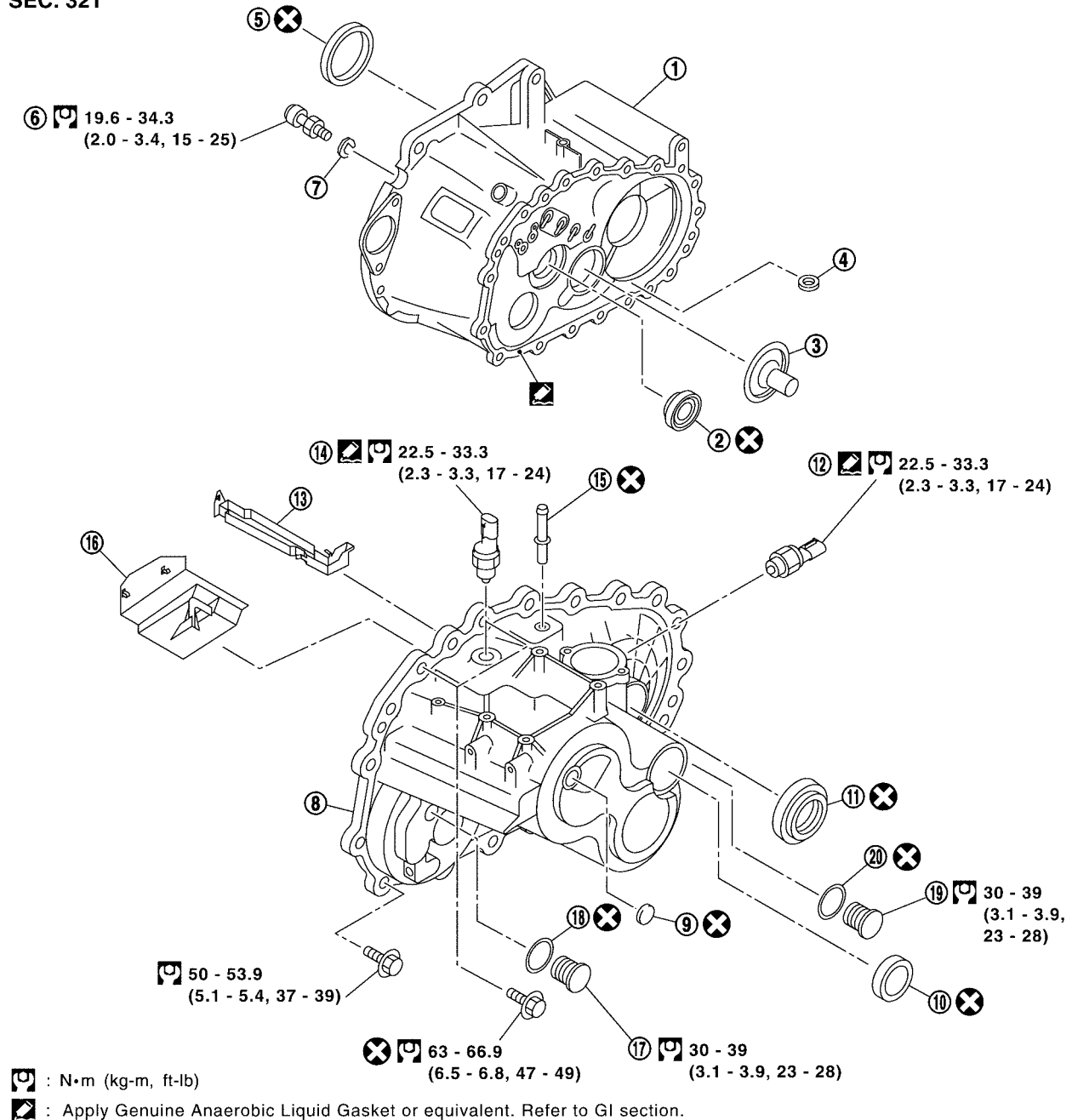

SCIA1062E

- | | | |
|-------------------|---------------------------|----------------------------------|
| 1. Clutch housing | 2. Input shaft oil seal | 3. Oil channel |
| 4. Magnet | 5. Differential oil seal | 6. Ball pin |
| 7. Washer | 8. Transaxle case | 9. Welch plug |
| 10. Bore plug | 11. Differential oil seal | 12. Park/Neutral position switch |
| 13. Oil gutter | 14. Back-up lamp switch | 15. Air breather tube |
| 16. Baffle plate | 17. Filler plug | 18. Gasket |
| 19. Drain plug | 20. Gasket | |

GEAR COMPONENTS

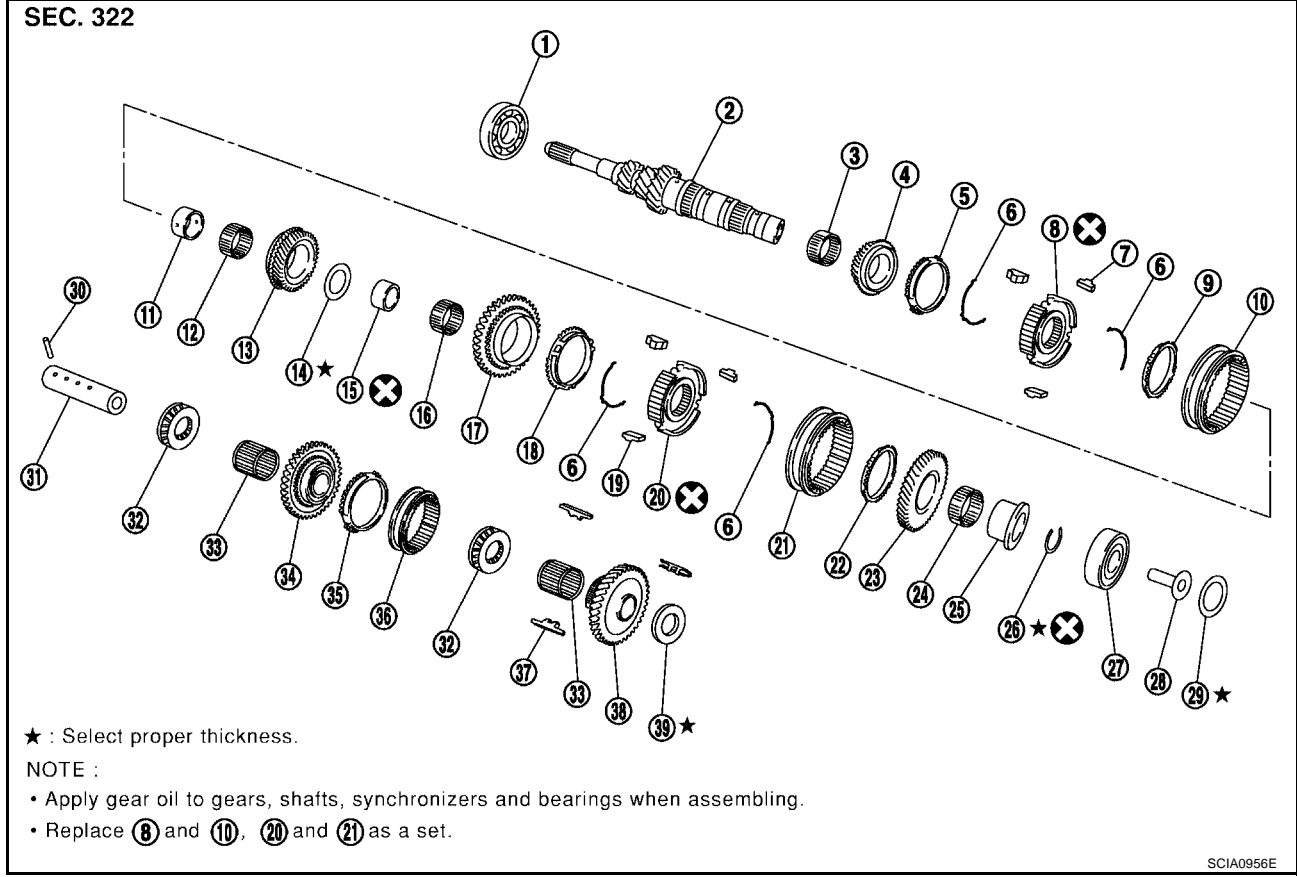

- | | | |
|--------------------------------|---------------------------------------------|---------------------------------------|
| 1. Input shaft front bearing | 2. Input shaft | 3. Needle bearing |
| 4. 3rd input gear | 5. 3rd baulk ring | 6. Spread spring |
| 7. 3rd & 4th shifting insert | 8. 3rd & 4th synchronizer hub | 9. 4th baulk ring |
| 10. 3rd & 4th coupling sleeve | 11. Bushing | 12. Needle bearing |
| 13. 4th input gear | 14. Thrust washer | 15. Bushing |
| 16. Needle bearing | 17. 5th input gear | 18. 5th baulk ring |
| 19. 5th & 6th shifting insert | 20. 5th & 6th synchronizer hub | 21. 5th & 6th coupling sleeve |
| 22. Baulk ring | 23. 6th input gear | 24. Needle bearing |
| 25. Bushing | 26. Snap ring | 27. Input shaft rear bearing |
| 28. Oil channel | 29. Input shaft rear bearing adjusting shim | 30. Retaining pin |
| 31. Reverse idler shaft | 32. Thrust bearing | 33. Needle bearing |
| 34. Reverse idler gear (Front) | 35. Reverse baulk ring | 36. Reverse coupling sleeve |
| 37. Insert spring | 38. Reverse idler gear (Rear) | 39. Reverse idler gear adjusting shim |

TRANSAXLE ASSEMBLY

[RS6F51H]

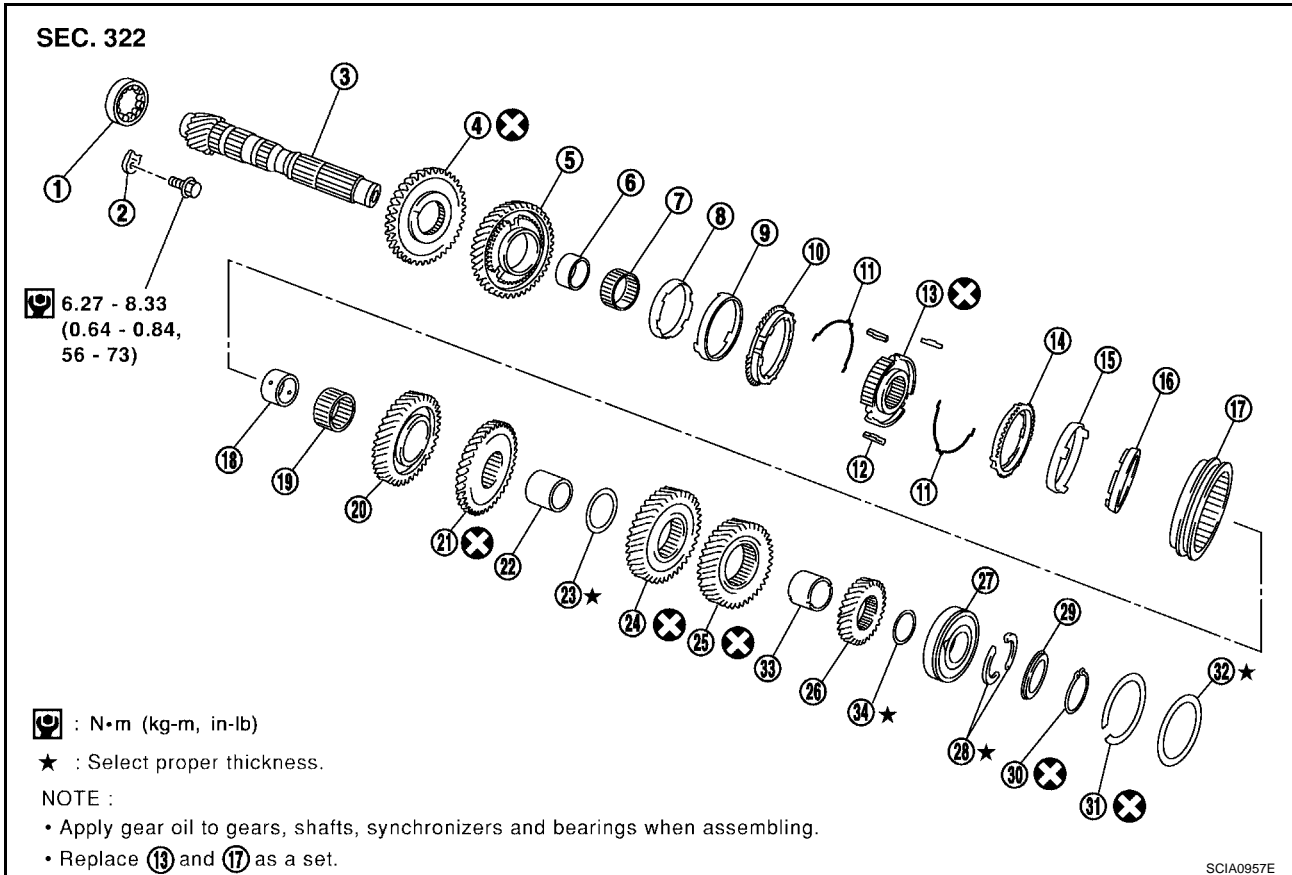

- | | | |
|--------------------------------|-------------------------------------------|--------------------------------|
| 1. Mainshaft front bearing | 2. Mainshaft bearing retainer | 3. Mainshaft |
| 4. Reverse main gear | 5. 1st main gear | 6. Bushing |
| 7. Needle bearing | 8. 1st inner baulk ring | 9. 1st gear synchronizer cone |
| 10. 1st outer baulk ring | 11. Spread spring | 12. 1st & 2nd shifting insert |
| 13. 1st & 2nd synchronizer hub | 14. 2nd outer baulk ring | 15. 2nd gear synchronizer cone |
| 16. 2nd inner baulk ring | 17. 1st & 2nd coupling sleeve | 18. Bushing |
| 19. Needle bearing | 20. 2nd main gear | 21. 3rd main gear |
| 22. 3rd & 4th mainshaft spacer | 23. 4th main adjusting shim | 24. 4th main gear |
| 25. 5th main gear | 26. 6th main gear | 27. Mainshaft rear bearing |
| 28. Mainshaft C-ring | 29. C-ring holder | 30. Snap ring |
| 31. Snap ring | 32. Mainshaft rear bearing adjusting shim | 33. 5th & 6th mainshaft spacer |
| 34. 6th main adjusting shim | | |

SHIFT CONTROL COMPONENTS

SEC. 328

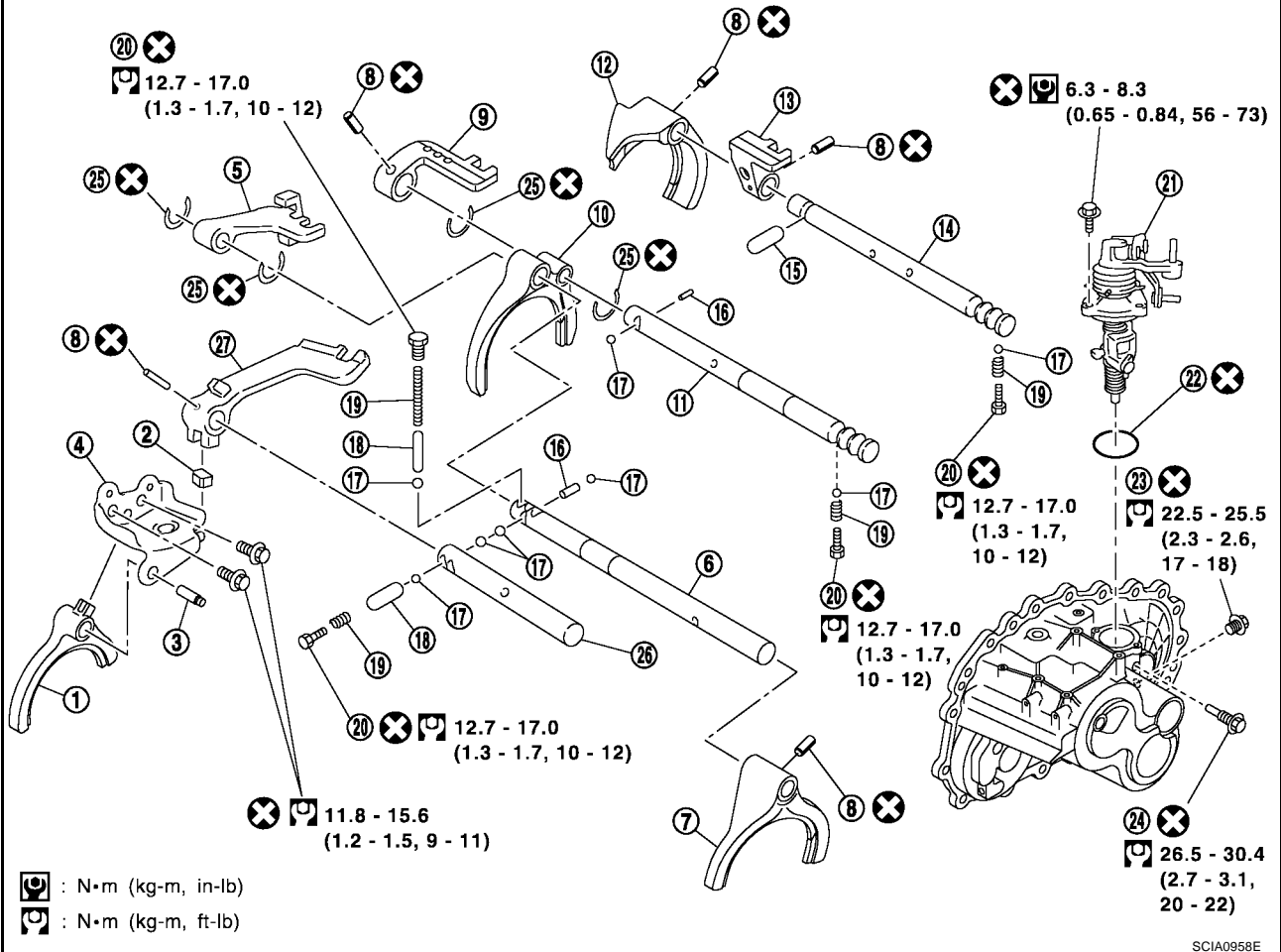

- | | | |
|---------------------------|------------------------------|--------------------------|
| 1. Reverse shift fork | 2. Shifter cap | 3. Reverse fork rod |
| 4. Reverse lever assembly | 5. 5th & 6th bracket | 6. 5th & 6th fork rod |
| 7. 5th & 6th shift fork | 8. Retaining pin | 9. 3rd & 4th bracket |
| 10. 3rd & 4th shift fork | 11. 3rd & 4th fork rod | 12. 1st & 2nd shift fork |
| 13. 1st & 2nd bracket | 14. 1st & 2nd fork rod | 15. Shift check sleeve |
| 16. Inter lock pin | 17. Check ball | 18. Shift check sleeve |
| 19. Check spring | 20. Check plug | 21. Control assembly |
| 22. O-ring | 23. Shift check | 24. Stopper bolt |
| 25. Stopper ring | 26. Reverse bracket fork rod | 27. Reverse bracket |

FINAL DRIVE COMPONENTS

SEC. 381

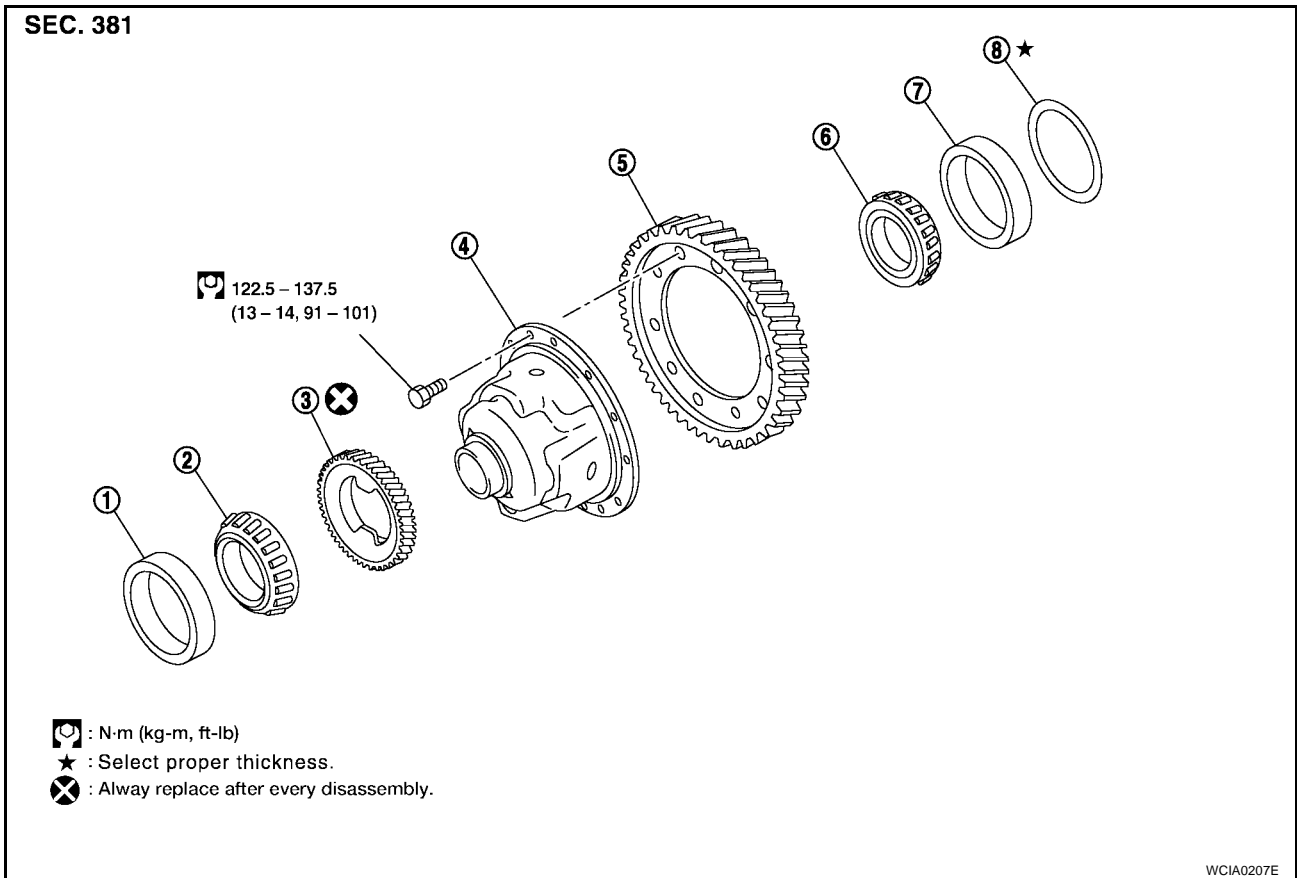

- : N·m (kg-m, ft-lb)
- : Select proper thickness.
- : Always replace after every disassembly.

- | | | |
|-----------------------------------------|---------------------------------------------|------------------------------|
| 1. Differential side bearing outer race | 2. Differential side bearing | 3. Speedometer drive gear |
| 4. Differential case | 5. Final gear | 6. Differential side bearing |
| 7. Differential side bearing outer race | 8. Differential side bearing adjusting shim | |

Disassembly and Assembly

DISASSEMBLY

ECS005VF

- Remove the drain plug and filler plug.
- Remove the park/neutral position switch and back-up lamp switch.
- After removing the shift check and stopper bolt, remove the control assembly.

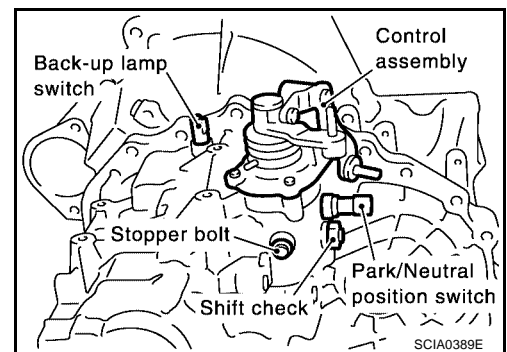

- Remove the check plugs (4 pieces), check springs (4 pieces), check balls (4 pieces), and shift check sleeve (2 pieces) as shown.

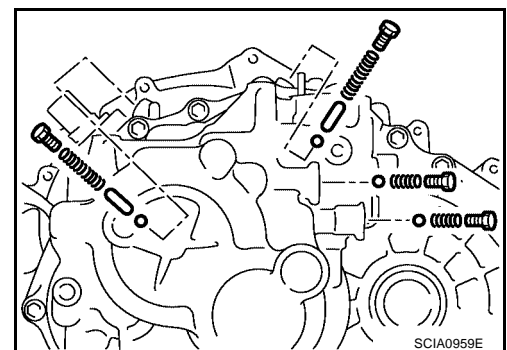

TRANSAXLE ASSEMBLY

[RS6F51H]

5. Remove the transaxle case fixing bolts as shown.

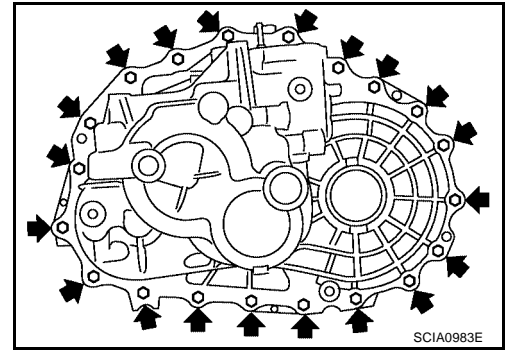

6. Remove the bore plug.

CAUTION:

Be careful not to damage transaxle case.

7. While spreading the snap ring of the mainshaft rear bearing located at bore plug hole, remove the transaxle case.
8. Remove the oil gutter and baffle plate.
9. Remove the snap ring, mainshaft rear bearing adjusting shim, and input shaft rear bearing adjusting shim from the transaxle case.
10. Remove the differential side bearing outer race (transaxle case side) using Tool as shown, and then remove the adjusting shim.

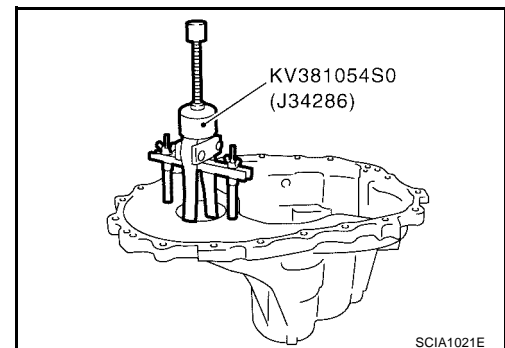

11. Remove the welch plug with a suitable punch and hammer as shown.

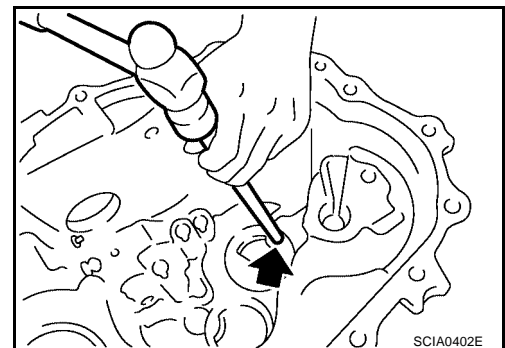

12. Remove the differential oil seal with a suitable tool as shown.

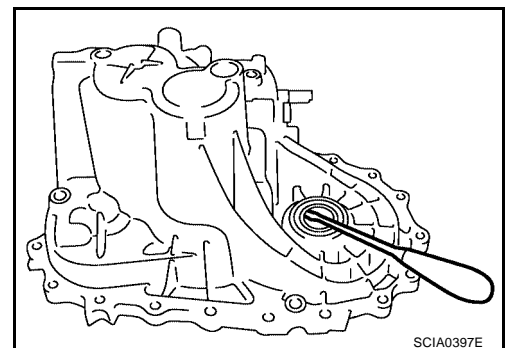

13. Remove the magnet from the clutch housing.

TRANSAXLE ASSEMBLY

[RS6F51H]

14. With the shift lever in 5th position, remove the bracket bolts from the reverse lever assembly as shown. Lift the reverse lever assembly to remove.

CAUTION:

Retain the shifter cap for installation.

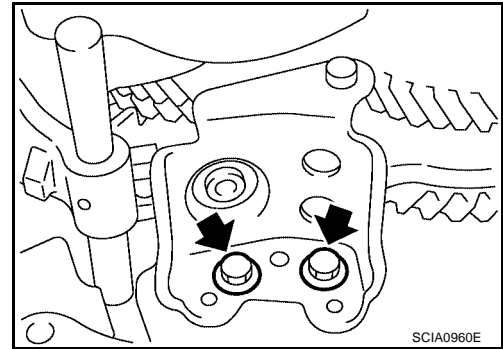

15. Pull out the reverse fork rod then remove the reverse shift fork.
16. Remove the retaining pin of the reverse bracket.

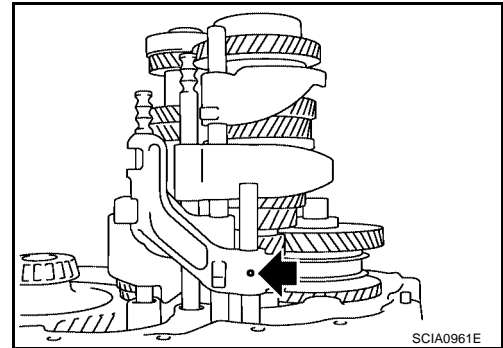

17. Pull out the reverse lever and the reverse bracket fork rod.
18. Remove the check ball (2 pieces) and the interlock pin.
19. Shift the 3rd-4th fork rod to the 3rd position. Remove the retaining pin of the 5th-6th shift fork using a pin punch.

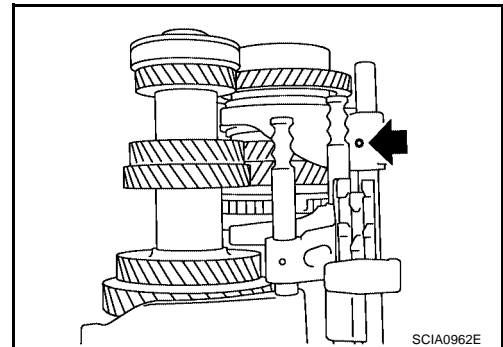

20. Remove the stopper rings for the 5th-6th bracket.

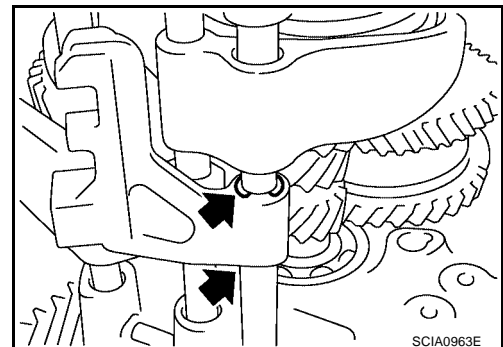

21. Pull out the 5th-6th fork rod and remove the 5th-6th shift fork and the 5th-6th bracket.
22. Remove the check balls (2 pieces) and interlock pin.

A
B
MT
D
E
F
G
H
I
J
K
L
M

TRANSAXLE ASSEMBLY

[RS6F51H]

23. Remove the retaining pin of 3rd-4th bracket using pin punch.
24. Remove the stopper rings for 3rd-4th shift fork.

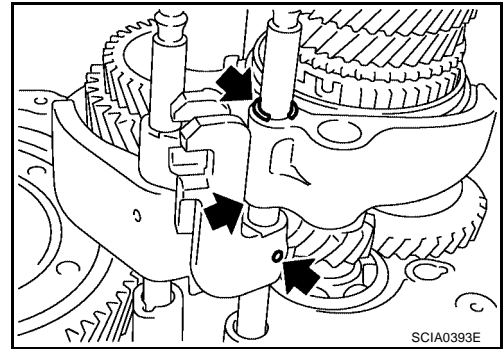

25. Pull out the 3rd-4th fork rod and remove 3rd-4th shift fork and bracket.
26. Remove the shift check sleeve from the clutch housing.
27. Remove the retaining pin of 1st-2nd shift fork using a suitable pin punch.

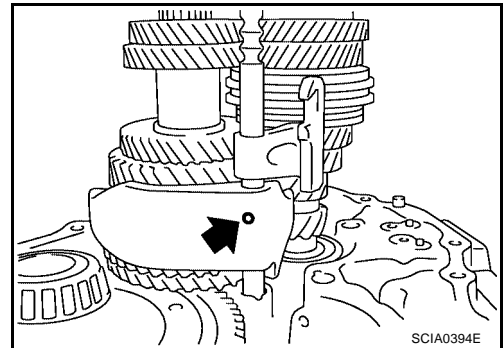

28. Pull out the 1st-2nd fork rod with bracket.
29. Remove the 1st-2nd shift fork.
30. Remove the retaining pin of 1st-2nd bracket using a suitable pin punch and separate the fork rod and bracket.
31. Remove the gear components from the clutch housing.
 - a. While tapping the input shaft with a plastic hammer, remove the input shaft assembly, mainshaft assembly, and reverse idler gear assembly as a set.

CAUTION:

Always withdraw the mainshaft straight out. Failure to do so can damage the resin oil channel on the clutch housing side.

- b. Remove the final drive assembly.

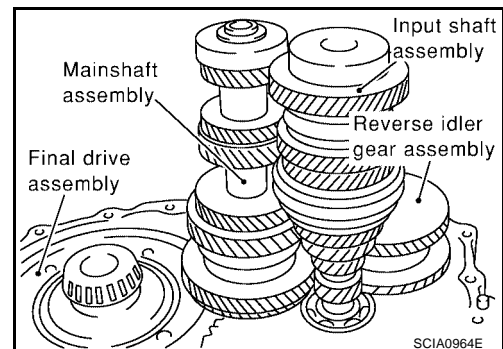

32. Remove the bearing retainer and then the mainshaft front bearing as shown.
33. Remove the oil channel on the mainshaft side.

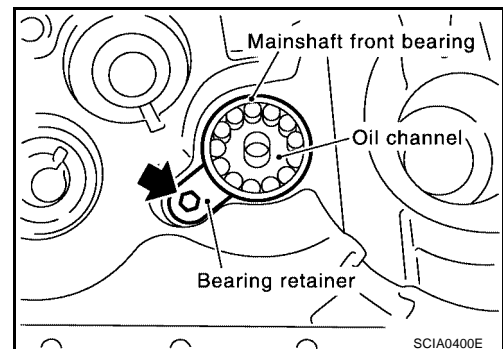

TRANSAXLE ASSEMBLY

[RS6F51H]

34. Remove the differential oil seal (clutch housing side) using Tool as shown.

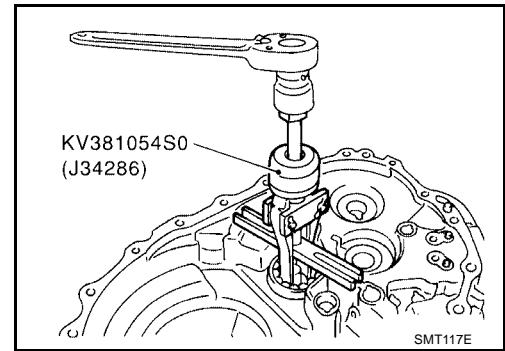

35. Remove the differential side bearing outer race (clutch housing side) using Tool as shown.

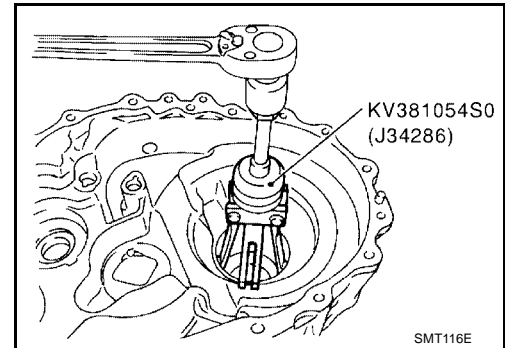

36. Remove the input shaft oil seal using a suitable tool as shown.

CAUTION:
Do not damage the clutch housing sealing surface.

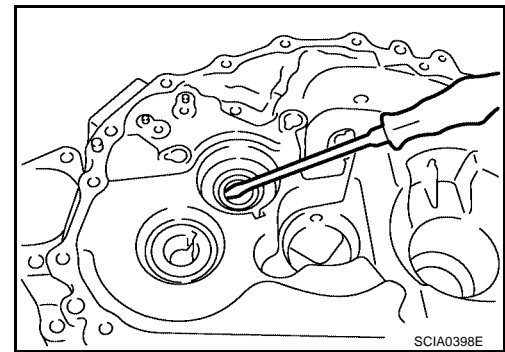

ASSEMBLY

1. Install a new input shaft oil seal from the clutch housing end of the side, to the depth of 1.8 - 2.8 mm (0.071 - 0.110 in) using Tool (drift) as shown.

CAUTION:
Oil seals are not reusable.

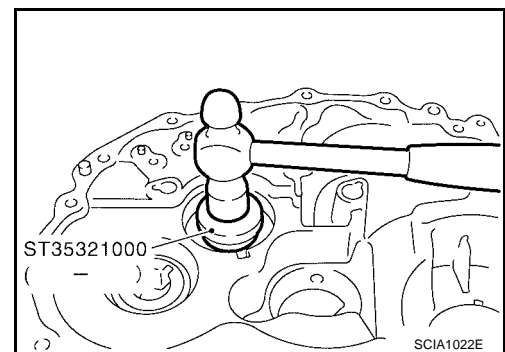

A
B
MT
D
E
F
G
H
I
J
K
L
M

TRANSAXLE ASSEMBLY

[RS6F51H]

2. Install a new differential oil seal using Tool (drift) as shown.

CAUTION:
Oil seals are not reusable.

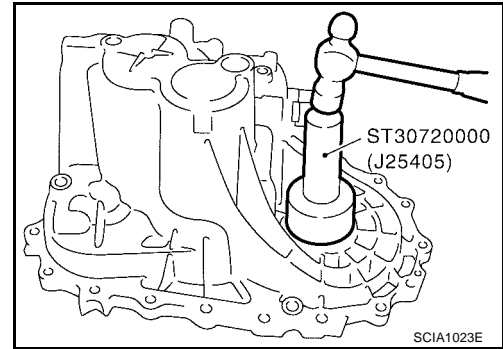

3. Install the oil channel on the mainshaft side as shown.

CAUTION:
Position the oil channel with the orientation as shown, for installation.

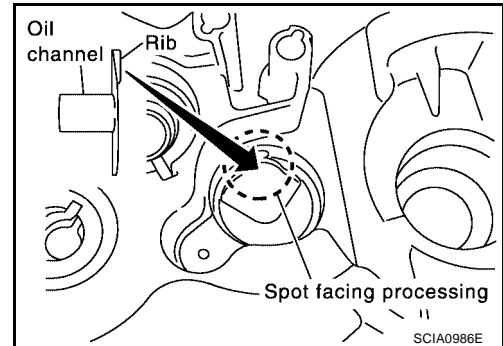

4. Install the mainshaft front bearing using Tool (drift) as shown.

CAUTION:
Position the mainshaft front bearing with the orientation as shown, for installation

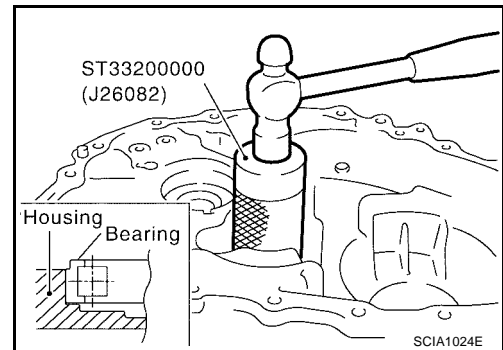

5. Install the mainshaft front bearing retainer.

CAUTION:
Install the bearing retainer with the punched surface facing up.

Bearing retainer bolt : 6.27 - 8.33 N-m (0.64 - 0.84 kg-m, 56 - 73 in-lb)

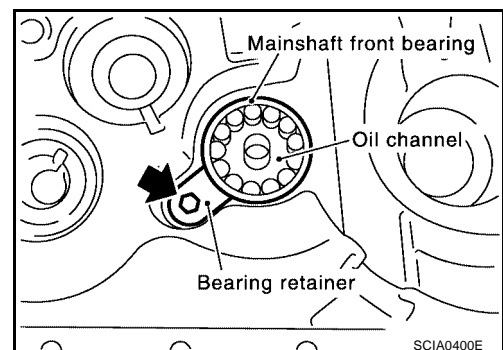

6. Install the differential side bearing outer race using Tool as shown.

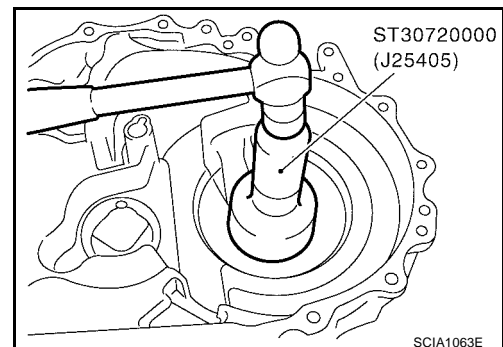

TRANSAXLE ASSEMBLY

[RS6F51H]

7. Install the final drive assembly into the clutch housing.

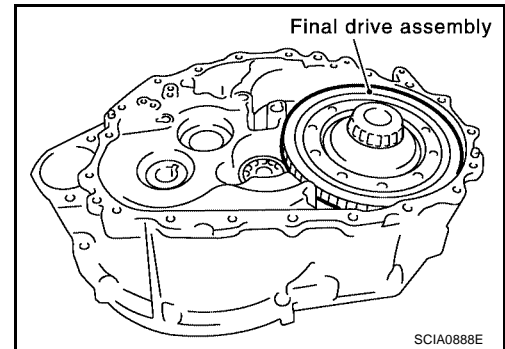

8. Install the input shaft assembly, mainshaft assembly, and reverse idler gear assembly into the clutch housing.

CAUTION:
Do not damage the input shaft oil seal.

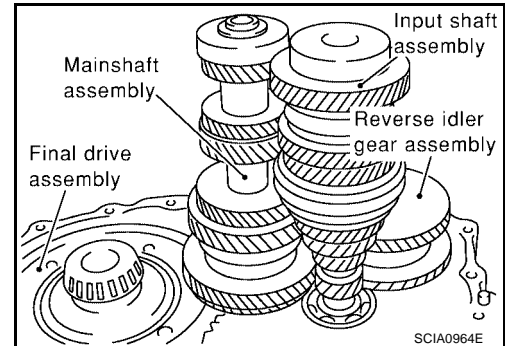

9. Install the 1st-2nd fork rod bracket onto the 1st-2nd fork rod, and then install a new retaining pin as shown.

CAUTION:
Retaining pins are not reusable.

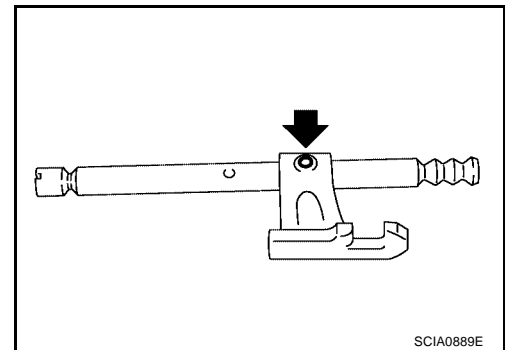

10. Install the 1st-2nd fork rod and the 1st-2nd shift fork, and then install a new retaining pin.

CAUTION:
Retaining pins are not reusable.

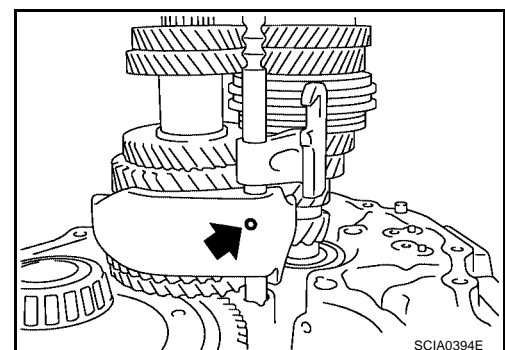

11. Install the shift check sleeve.

12. Install the 3rd-4th bracket, 3rd-4th shift fork, and 3rd-4th fork rod with the interlock pin.

A
B
MT
D
E
F
G
H
I
J
K
L
M

TRANSAXLE ASSEMBLY

[RS6F51H]

13. Install the new stopper rings onto the 3rd-4th shift fork.

CAUTION:
Stopper rings are not reusable.

14. Install a new retaining pin onto the 3rd-4th bracket.

CAUTION:
Retaining pins are not reusable.

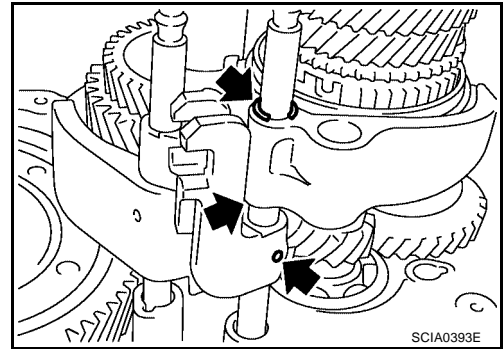

15. Install the 2 check balls.
16. Install the 5th-6th bracket, 5th-6th shift fork, and 5th-6th fork rod.
17. Install new stopper rings onto the 5th-6th bracket with interlock pin.

CAUTION:
Stopper rings are not reusable.

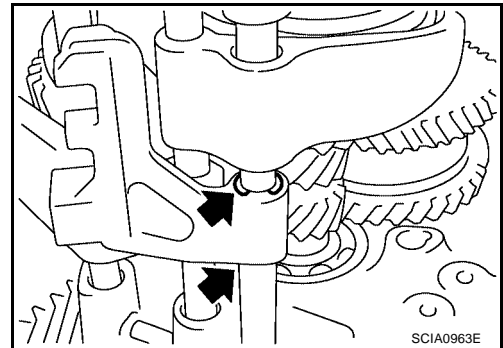

18. Install a new retaining pin onto the 5th-6th shift fork.

CAUTION:
Retaining pins are not reusable.

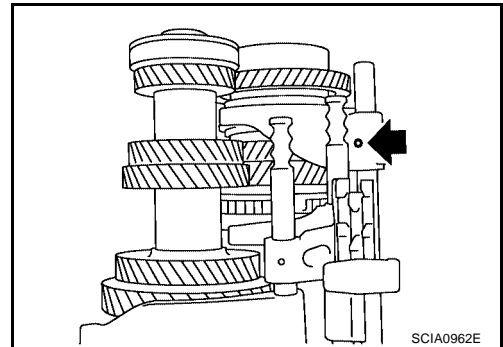

19. Install the two check balls.
20. Install the reverse bracket fork rod and reverse lever bracket.
21. Install a new retaining pin onto the reverse bracket.

CAUTION:
Retaining pins are not reusable.

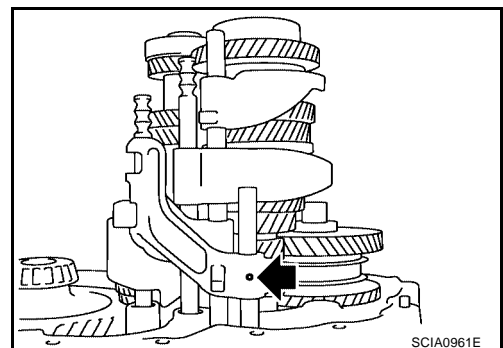

22. Install the reverse shift fork and reverse fork rod.
23. Install the reverse lever assembly using the following steps:
a. Install the shifter cap onto the reverse lever assembly cam, and then install them onto the reverse shift fork.

CAUTION:

Do not drop the shifter cap.

- b. While lifting the reverse shift fork, align the cam with the reverse bracket.

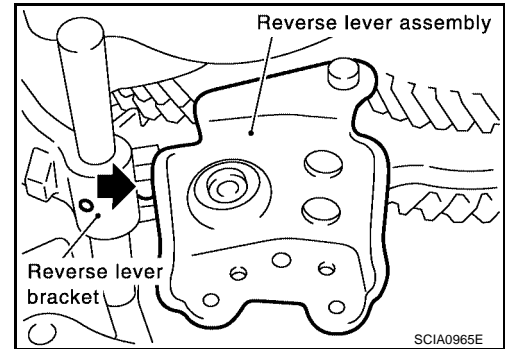

- c. Tighten the bracket bolts to specification, and install the reverse lever assembly.

Bracket bolts : 11.8 - 15.6 N·m (1.2 - 1.5 kg·m, 9 - 11 ft·lb)

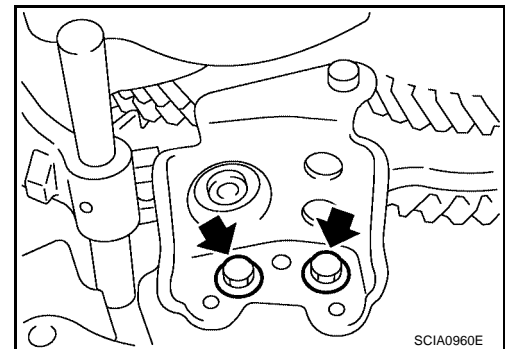

24. Install the magnet onto the clutch housing.
 25. Install the selected input shaft adjusting shim onto the input shaft.
 ● For selection of adjusting shims, refer to [MT-160, "INPUTSHAFT END PLAY"](#) .
 26. Install the baffle plate and oil gutter.
 27. Install the transaxle case using the following steps:
 a. Install the selected mainshaft rear bearing adjusting shim into the transaxle case.
 ● For selection of adjusting shims, refer to [MT-162, "MAINSHAFT END PLAY"](#) .
 b. Temporarily install the snap ring of the mainshaft rear bearing into the transaxle case.

CAUTION:

Do not reuse the snap ring.

- c. Apply sealant to the mating surfaces of the transaxle case and clutch housing as shown. Use Genuine Anaerobic Liquid Gasket or equivalent. Refer to [GI-44, "Recommended Chemical Products and Sealants"](#) .

CAUTION:

Remove any old sealant adhering to the mounting surfaces. Also remove any moisture, oil, or foreign material adhering to the sealant application and mounting surfaces.

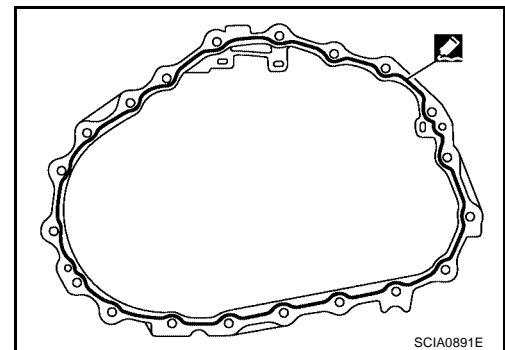

TRANSAXLE ASSEMBLY

[RS6F51H]

- d. Using a snap ring of the mainshaft rear bearing temporarily, install the transaxle case over the clutch housing as shown.

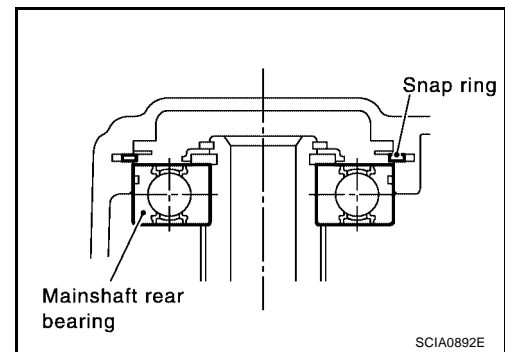

- e. Through the bore plug mounting hole, with the snap ring stretched, lift up the mainshaft assembly from the control assembly mounting hole.
- f. Securely install the snap ring onto the mainshaft rear bearing as shown.

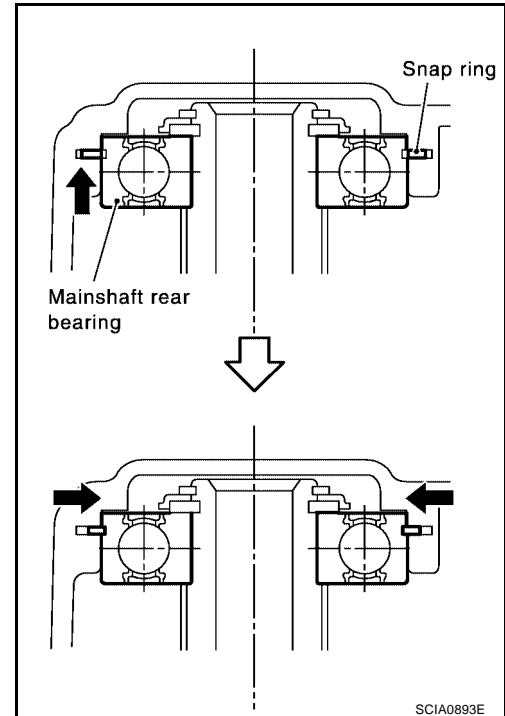

- g. Tighten the "A" bolts (gold) and new "B" bolts (black) to specification.

"A" Bolt : 50.0 - 53.9 N-m (5.1 - 5.4 kg-m, 37 - 39 ft-lb)

"B" Bolt : 63.0 - 66.9 N-m (6.5 - 6.8 kg-m, 47 - 49 ft-lb)

CAUTION:

Always replace the "B" bolts as they are self-sealing bolts.

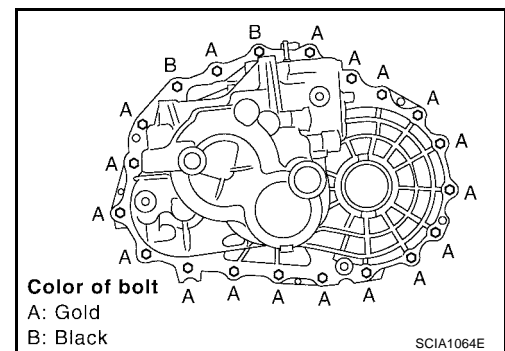

- h. Install the control assembly using new O-rings.

CAUTION:

Do not reuse the O-ring.

- i. Install a new shift check and a new stopper bolt.

CAUTION:

Shift check and stopper bolt are not reusable.

TRANSAXLE ASSEMBLY

[RS6F51H]

28. Install a new bore plug using Tool (drift) as shown.

CAUTION:
Bore plugs are not reusable.

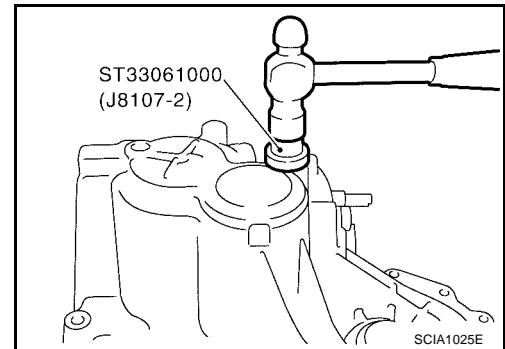

29. Install the new welch plug using Tool (drift).

CAUTION:
Do not reuse the welch plug

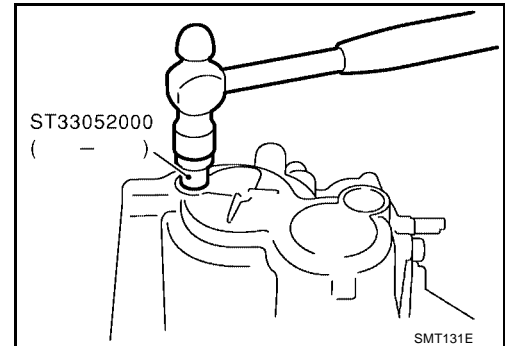

30. Install the 2 shift check sleeves, 4 check balls, 4 check springs, and 4 new check ball plugs.

CAUTION:
Check ball plugs are not reusable.

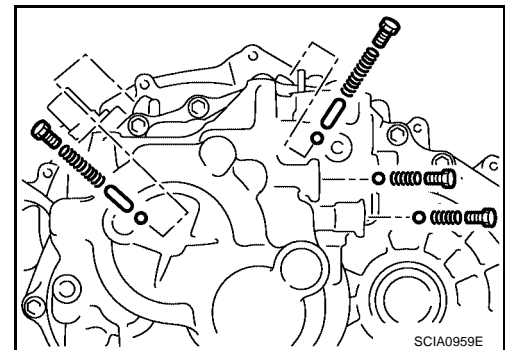

31. Apply sealant to the threads of the neutral switch and reverse lamp switch. Then install them into the transaxle case. Refer to [MT-145, "CASE AND HOUSING COMPONENTS"](#) . Use Genuine Anaerobic Liquid Gasket or equivalent. Refer to [GI-44, "Recommended Chemical Products and Sealants"](#) .

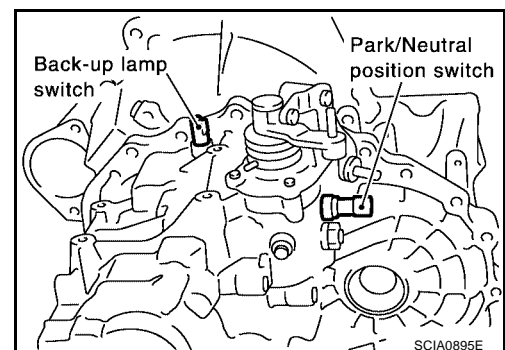

32. Install new gaskets onto the drain plug and filler plug, and then install them into the transaxle case.

CAUTION:

- Gaskets are not reusable.
- After oil is filled, tighten filler plug to specification. Refer to [MT-145, "CASE AND HOUSING COMPONENTS"](#) .

A
B
MT
D
E
F
G
H
I
J
K
L
M

Adjustment INPUTSHAFT END PLAY

- When adjusting the input shaft end play, select the adjusting shim for the input shaft bearing. To select the correct thickness for the adjusting shim, measure the clearance between the transaxle case and input shaft rear bearing.
- Calculate the dimension "O" (thickness of adjusting shim) using the following steps to adjust the input shaft rear bearing for the specified end play.

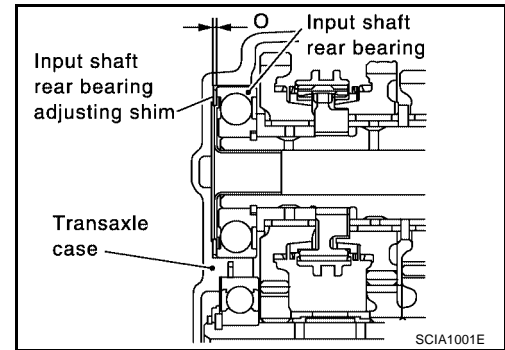

CAUTION:

Only 1 adjusting shim can be selected.

End play : 0 - 0.06 mm (0 - 0.0024 in)

Dimension "O" = (O₁ - O₂) + End play

"O" : Thickness of adjusting shim

O₁ : Distance between transaxle case end face and mounting face of adjusting shim

O₂ : Distance between clutch housing case end face and end face of input shaft rear bearing

Adjusting Shims

Shim thickness	Part number	Shim thickness	Part number	Shim thickness	Part number
0.40 mm (0.0157 in)	32225 8H500	0.88 mm (0.0346 in)	32225 8H512	1.36 mm (0.0520 in)	32225 8H524
0.44 mm (0.0173 in)	32225 8H501	0.92 mm (0.0362 in)	32225 8H513	1.40 mm (0.0551 in)	32225 8H560
0.48 mm (0.0189 in)	32225 8H502	0.96 mm (0.0378 in)	32225 8H514	1.44 mm (0.0567 in)	32225 8H561
0.52 mm (0.0205 in)	32225 8H503	1.00 mm (0.0396 in)	32225 8H515	1.48 mm (0.0583 in)	32225 8H562
0.56 mm (0.0220 in)	32225 8H504	1.04 mm (0.0409 in)	32225 8H516	1.52 mm (0.0598 in)	32225 8H563
0.60 mm (0.0236 in)	32225 8H505	1.08 mm (0.0425 in)	32225 8H517	1.56 mm (0.0614 in)	32225 8H564
0.64 mm (0.0252 in)	32225 8H506	1.12 mm (0.0441 in)	32225 8H518	1.60 mm (0.0630 in)	32225 8H565
0.68 mm (0.0268 in)	32225 8H507	1.16 mm (0.0457 in)	32225 8H519	1.64 mm (0.0646 in)	32225 8H566
0.72 mm (0.0283 in)	32225 8H508	1.20 mm (0.0472 in)	32225 8H520		
0.76 mm (0.0299 in)	32225 8H509	1.24 mm (0.0488 in)	32225 8H521		
0.80 mm (0.0315 in)	32225 8H510	1.28 mm (0.0504 in)	32225 8H522		
0.84 mm (0.0331 in)	32225 8H511	1.32 mm (0.0520 in)	32225 8H523		

- Using a depth micrometer and straight edge, measure the dimension "O₁" between the transaxle case end face and mounting face of the adjusting shim as shown.

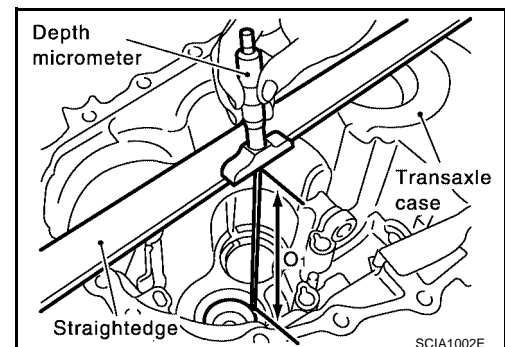

TRANSAXLE ASSEMBLY

[RS6F51H]

- Using a depth micrometer and straight edge, measure the dimension "O₂" between the clutch housing case end face and end face of the input shaft rear bearing as shown.

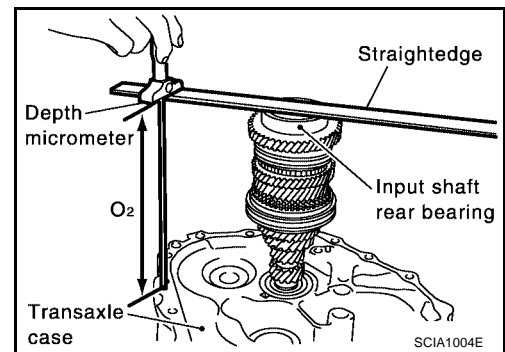

- Install the selected input shaft rear bearing adjusting shim onto the input shaft.

DIFFERENTIAL SIDE BEARING PRELOAD

- When adjusting differential side bearing preload, select adjusting shim for differential side bearing. To select adjusting shim, measure clearance "L" between transaxle case and differential side bearing outer race.
- Calculate dimension "L" (thickness of adjusting shim) using the following procedure to meet specification of preload for differential side bearing.

Preload : 0.15 - 0.21 mm (0.0059 - 0.0083 in)

Dimension "L" = (L₁ - L₂) + Preload

"L" : Thickness of adjusting shim

L₁ : Distance between clutch housing case end face and mounting face of adjusting shim

L₂ : Distance between differential side bearing and transaxle case

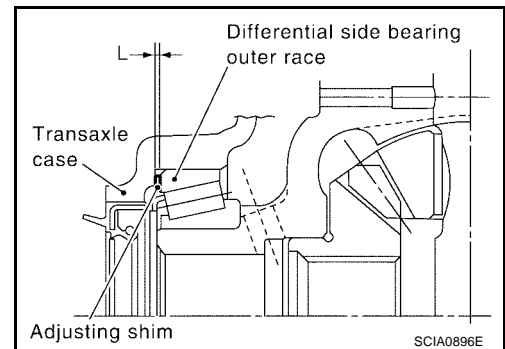

CAUTION:

Up to only 2 adjusting shims can be selected.

Adjusting Shim

Shim thickness	Part number
0.48 mm (0.0189 in)	31438 80X00
0.52 mm (0.0205 in)	31438 80X01
0.56 mm (0.0220 in)	31438 80X02
0.60 mm (0.0236 in)	31438 80X03
0.64 mm (0.0252 in)	31438 80X04
0.68 mm (0.0268 in)	31438 80X05
0.72 mm (0.0283 in)	31438 80X06
0.76 mm (0.0299 in)	31438 80X07
0.80 mm (0.0315 in)	31438 80X08
0.84 mm (0.0331 in)	31438 80X09
0.88 mm (0.0346 in)	31438 80X10
0.92 mm (0.0362 in)	31438 80X11

- Using a depth micrometer and straight edge, measure the dimension "L₁" between the clutch housing case end face and mounting face of the adjusting shim as shown.

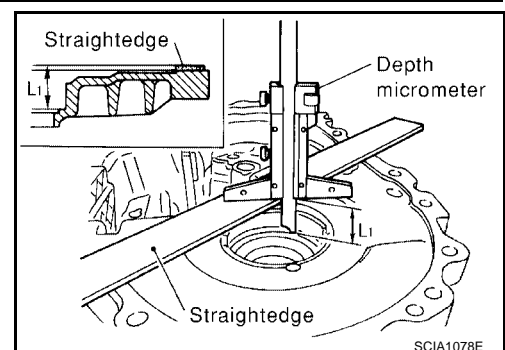

TRANSAXLE ASSEMBLY

[RS6F51H]

2. Install the outer race onto the differential side bearing on the final gear side. Holding the outer race horizontally by hand, rotate the final gear five times or more (for smooth movement of the bearing roller).
3. Using a depth micrometer and straight edge, measure the dimension "L2" between the differential side bearing outer race and transaxle case end face as shown.

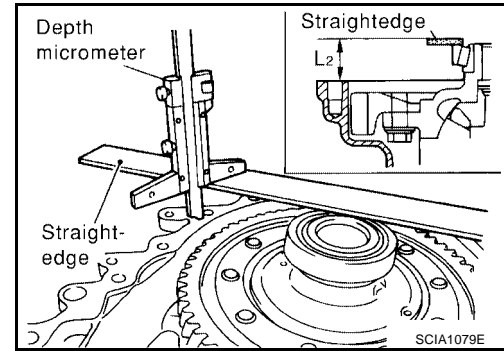

4. Install the selected adjusting shim and then the differential side bearing outer race using Tool as shown.

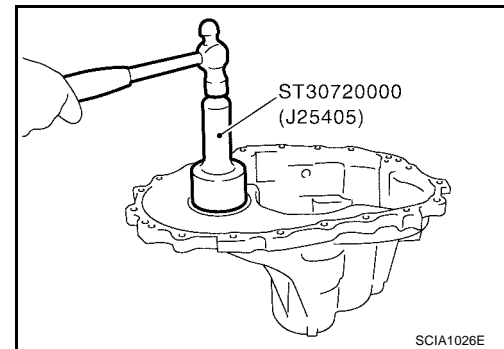

MAINSHAFT END PLAY

- When adjusting the mainshaft end play, select the adjusting shim for the mainshaft rear bearing. To select the adjusting shim, measure clearance "M" between the transaxle case and mainshaft rear bearing.
- Calculate the dimension "P" (thickness of adjusting shim) using the following procedure to meet specification of end play for mainshaft rear bearing.

End play : 0 - 0.06 mm (0 - 0.0024 in)

Dimension "P" = "M" + End play

"P" : Thickness of adjusting shim

"M" : Distance between mainshaft rear bearing and transaxle case

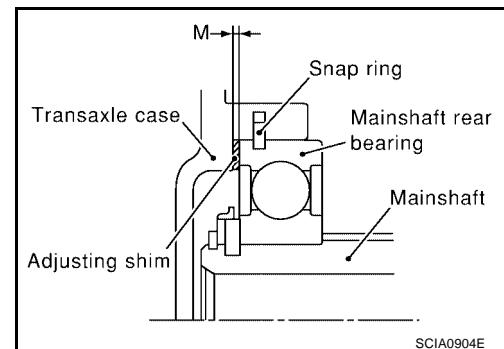

CAUTION:

Only 1 adjusting shim can be selected.

Adjusting Shim

Shim thickness	Part number
0.44 mm (0.0173 in)	32238 8H510
0.48 mm (0.0189 in)	32238 8H511
0.52 mm (0.0205 in)	32238 8H512
0.56 mm (0.0220 in)	32238 8H513
0.60 mm (0.0236 in)	32238 8H514
0.64 mm (0.0252 in)	32238 8H515
0.68 mm (0.0268 in)	32238 8H516
0.72 mm (0.0283 in)	32238 8H517
0.76 mm (0.0299 in)	32238 8H518
0.80 mm (0.0315 in)	32238 8H519
0.84 mm (0.0331 in)	32238 8H520
0.88 mm (0.0346 in)	32238 8H521
0.92 mm (0.0362 in)	32238 8H522
0.96 mm (0.0378 in)	32238 8H523
1.00 mm (0.0396 in)	32238 8H524
1.04 mm (0.0409 in)	32238 8H560
1.08 mm (0.0425 in)	32238 8H561

1. Install the mainshaft assembly to the clutch housing.
2. Install the snap ring to the transaxle case.
3. Install the transaxle case to clutch housing, and temporarily assemble them with fixing bolts. Temporarily install the snap ring to the mainshaft rear bearing.
4. Install the dial gauge to the snap ring access hole, and expand the snap ring as shown. Lift the mainshaft assembly through the control assembly installation hole, and push it against the transaxle case. This state shall be defined as base. Moving the distance of the mainshaft assembly, with the snap ring installed on the main bearing, becomes "M".

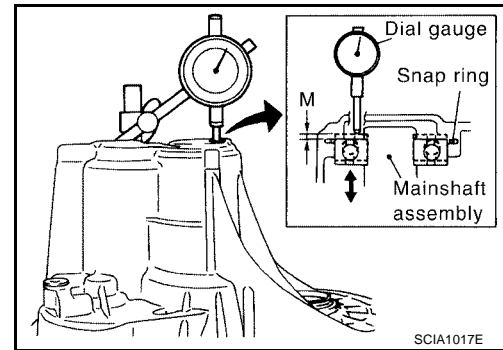

REVERSE IDLER GEAR END PLAY

- When adjusting the reverse idler gear end play, select the adjusting shim for the reverse idler gear. To select the correct thickness of adjusting shim, measure the clearance between the transaxle case and reverse idler gear.
- Calculate the dimension "Q" (thickness of adjusting shim) using the following steps to adjust the end play of the reverse idler gear to specification.

End play : 0.04 - 0.14 mm (0.0016 - 0.0055 in)

Dimension "Q" = (Q₁ - Q₂) + End play

"Q" : Thickness of adjusting shim

Q₁ : Distance between transaxle case end face and mounting face of adjusting shim

Q₂ : Distance between clutch housing case end face and end face of reverse idler gear

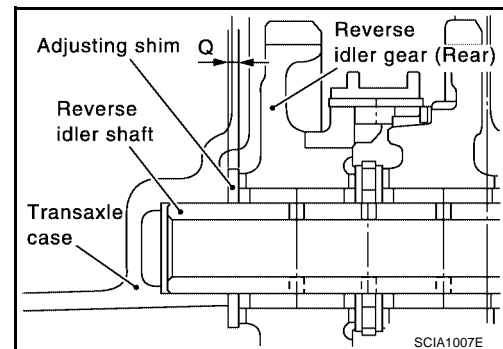

CAUTION:

Only 1 adjusting shim can be selected.

TRANSAXLE ASSEMBLY

[RS6F51H]

Adjusting Shim

Shim thickness	Part number
1.76 mm (0.0693 in)	32237 8H500
1.84 mm (0.0724 in)	32237 8H501
1.92 mm (0.0756 in)	32237 8H502
2.00 mm (0.0787 in)	32237 8H503
2.08 mm (0.0819 in)	32237 8H504
2.16 mm (0.0850 in)	32237 8H505
2.24 mm (0.0882 in)	32237 8H506
2.32 mm (0.0913 in)	32237 8H507
2.40 mm (0.0945 in)	32237 8H508
2.48 mm (0.0976 in)	32237 8H509
2.56 mm (0.1008 in)	32237 8H510
2.64 mm (0.1039 in)	32237 8H511

1. Using a depth micrometer and straight edge, measure the dimension "Q₁" between the transaxle case end face and the mounting face of the adjusting shim as shown.

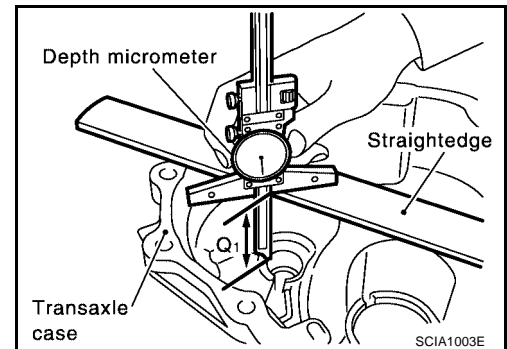

2. Using a depth micrometer and straight edge, measure the dimension "Q₂" between the clutch housing case end face and the end face of reverse idler gear as shown.

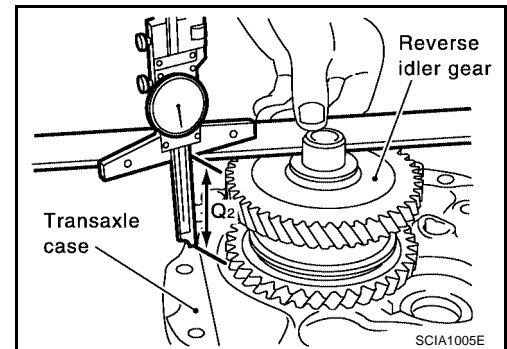

3. Install the selected reverse idler gear adjusting shim onto the reverse idler gear.

INPUT SHAFT AND GEARS

Disassembly and Assembly

DISASSEMBLY

1. Before disassembling, measure the end play for 3rd, 4th, 5th, and 6th input gears.

End play standard values

3rd gear : 0.18 - 0.31 mm (0.0071 - 0.0122 in)

4th gear : 0.20 - 0.30 mm (0.0079 - 0.0118 in)

5th gear : 0.06 - 0.16 mm (0.0024 - 0.0063 in)

6th gear : 0.06 - 0.16 mm (0.0024 - 0.0063 in)

CAUTION:

If measurement is outside the standard value, disassemble to check the contact surfaces of the gear, shaft, and, hub. Adjust using the correct size snap ring for assembly.

2. Remove the oil channel.
3. Remove the input shaft rear bearing using Tool as shown.
4. Remove the snap ring.

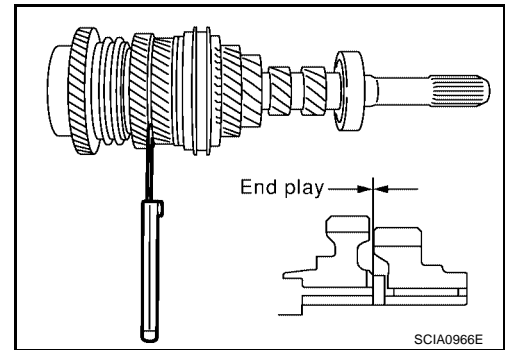

5. Remove the 6th input gear, 6th bushing, and 6th needle bearing using Tool as shown.
6. Remove the 6th baulk ring, 5th-6th coupling sleeve, and shifting insert.

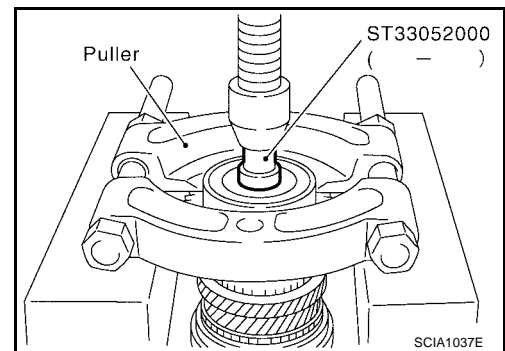

7. Remove the 5th input gear and synchronizer hub assembly simultaneously using Tool as shown.
8. Remove the 5th needle bearing.

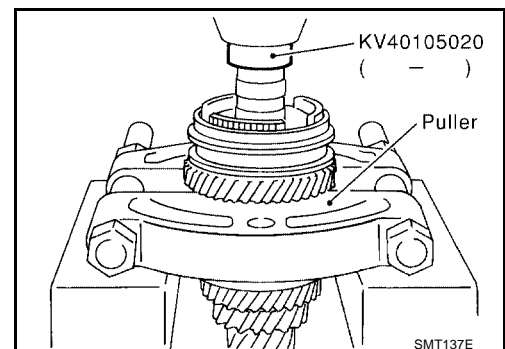
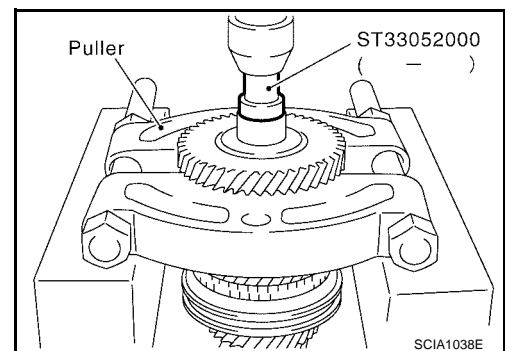

A
B
MT
D
E
F
G
H
I
J
K
L
M

9. Remove the 5th bushing, thrust washer, 4th input gear, 4th needle bearing, 4th bushing, 4th baulk ring, 3rd-4th synchronizer hub assembly, 3rd baulk ring, and 3rd input gear simultaneously using Tool as shown.
10. Remove the 3rd needle bearing.

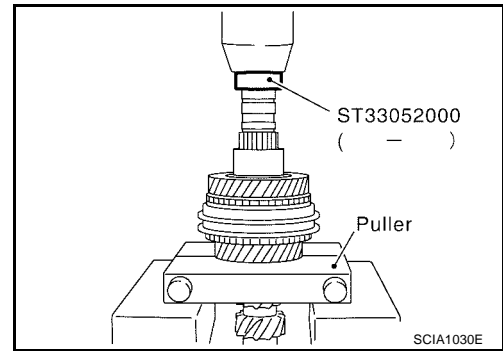

11. Remove the input shaft front bearing using Tool as shown.

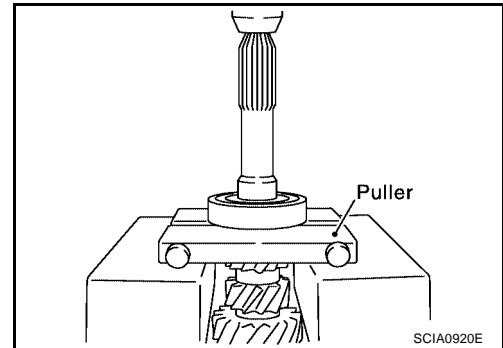

INSPECTION AFTER DISASSEMBLY

Input Shaft and Gears

Inspect the components for the following conditions as shown. If necessary, replace them with new ones.

- Damage, peeling, dent, uneven wear, or bending of the input shaft.
- Excessive wear, damage, or peeling of the input gears.

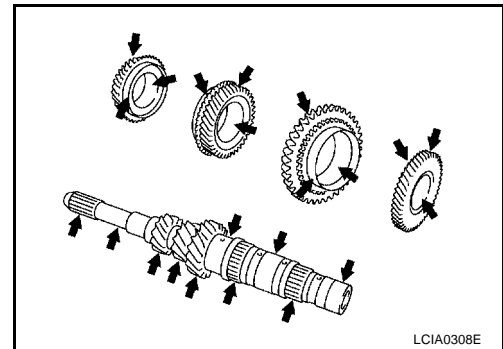

Synchronizer

Check the items below. If necessary, replace them with new ones.

- Damage and excessive wear of the contact surfaces of coupling sleeve, synchronizer hub, and shifting insert.
- Coupling sleeve and synchronizer hub must move smoothly as shown.

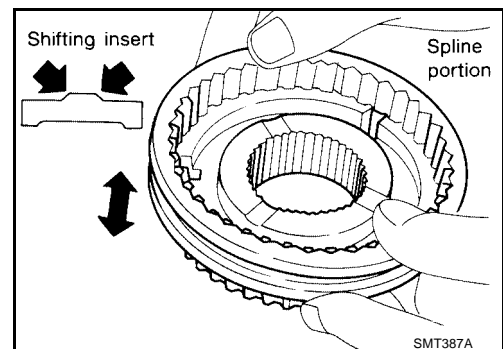

INPUT SHAFT AND GEARS

[RS6F51H]

- If any cracks, damage, or excessive wear is found on the cam face of baulk ring or working face of the insert as shown, replace it.

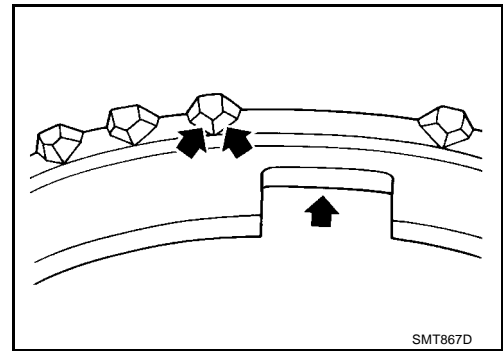

Baulk Ring Clearance

Check the items below. If necessary, replace them with new ones.

- Press the baulk ring against cone, and measure clearance between baulk ring and cone. If measurement is below limit, replace it with a new one.

Clearance - standard

3rd and 4th : 0.9 - 1.45 mm (0.035 - 0.0571 in)

5th and 6th : 0.95 - 1.4 mm (0.0374 - 0.055 in)

Limit : 0.7 mm (0.028 in)

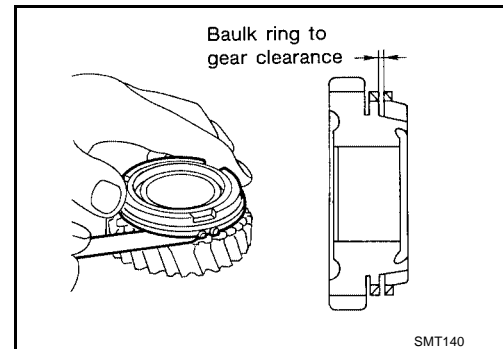

Bearing

Check the items below. If necessary, replace them with new ones.

- Damage and rough rotation of the bearing as shown.

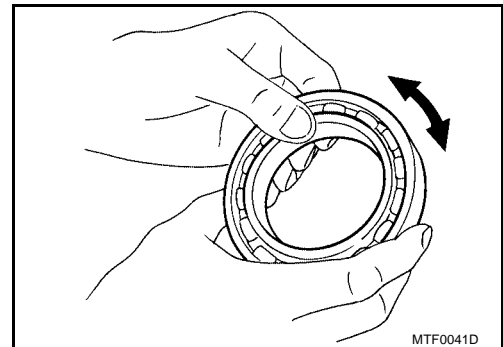

ASSEMBLY

1. Install the 3rd needle bearing.
2. Install the 3rd input gear and 3rd baulk ring.
3. Install the spread spring, shifting insert, and a new 3rd-4th synchronizer hub onto the 3rd-4th coupling sleeve.

CAUTION:

- Install with orientation of the synchronizer hub as shown.
- Do not reuse the 3rd-4th synchronizer hub.

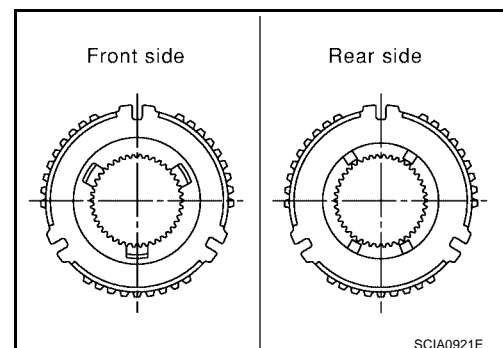

A
B
MT
D
E
F
G
H
I
J
K
L
M

INPUT SHAFT AND GEARS

[RS6F51H]

- Install with orientation of coupling sleeve as shown.

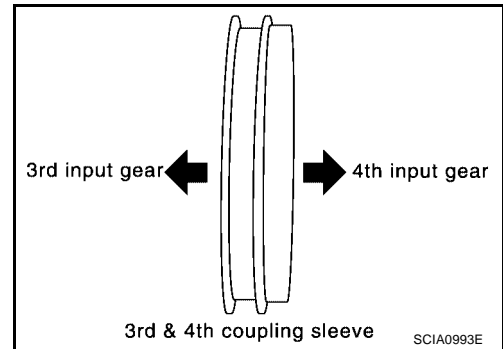

- Be sure not to hook the ends of the 2 spread springs (front and back have two each) on the same shifting insert.

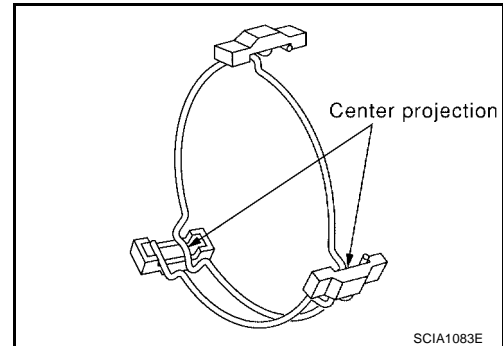

4. Install 3rd-4th synchronizer hub assembly using Tool as shown.

CAUTION:
Align grooves of shifting insert and 3rd baulk ring.

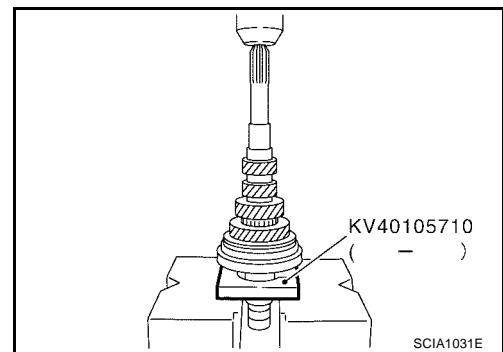

5. Install the 4th bushing using Tool as shown.
6. Install the 4th baulk ring.
7. Install the 4th input gear and 4th needle bearing.

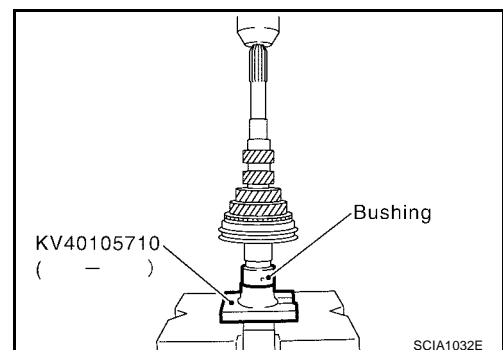

INPUT SHAFT AND GEARS

[RS6F51H]

8. Measure the dimension "C2" as shown. Select a thrust washer so that dimension "C2" satisfies standard dimension specification. Then install the thrust washer onto the input shaft.

**Standard for dimension "C2" : 154.7 - 154.8 mm
(6.091 - 6.094 in)**

CAUTION:

Only 1 thrust washer can be selected.

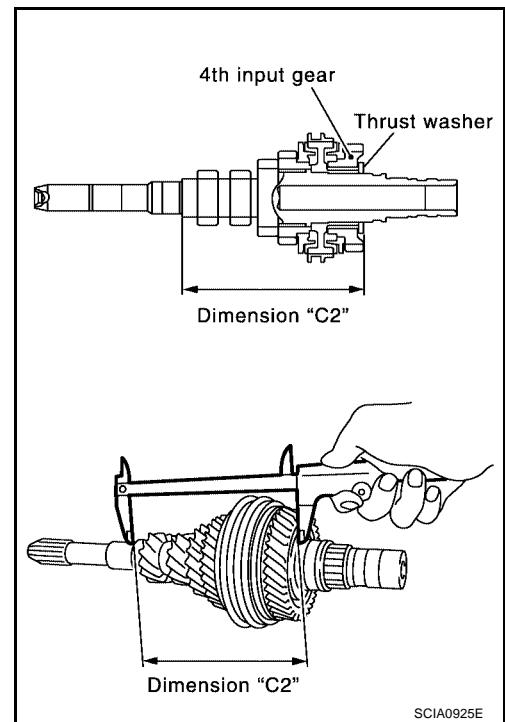

Thrust Washer

Thickness	Part number	Thickness	Part number
3.84 mm (0.1512 in)	32347 8H500	4.02 mm (0.1583 in)	32347 8H503
3.90 mm (0.1535 in)	32347 8H501	4.08 mm (0.1606 in)	32347 8H504
3.96 mm (0.1559 in)	32347 8H502	4.14 mm (0.1630 in)	32347 8H505

9. Install the 5th bushing using Tool as shown.
 10. Install the 5th needle bearing and 5th input gear.
 11. Install the 5th baulk ring.

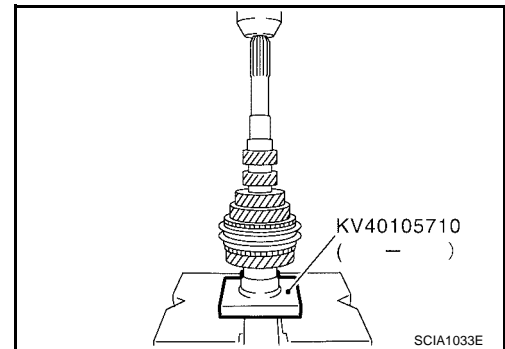

12. Install the synchronizer assembly onto a new 5th-6th synchronizer hub.

CAUTION:

- Install with the orientation of the synchronizer hub as shown.
- Do not reuse the 5th-6th synchronizer hub.

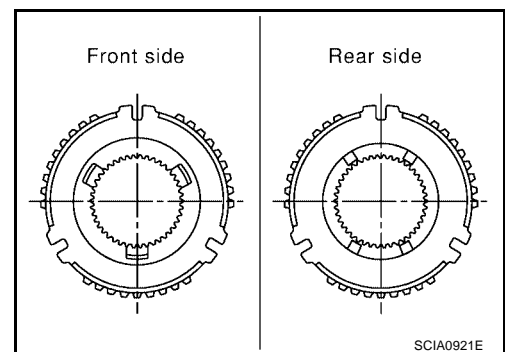

A
B
MT
D
E
F
G
H
I
J
K
L
M

INPUT SHAFT AND GEARS

[RS6F51H]

- Be sure not to hook the ends of the 2 spread springs (front and back have two each) on the same shifting insert.

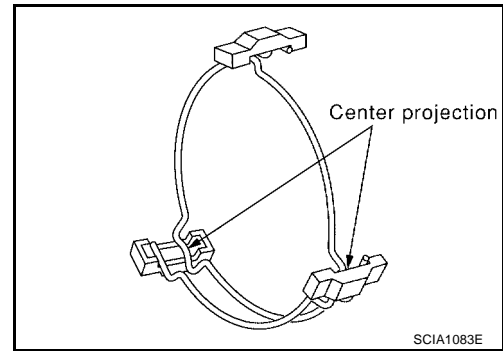

13. Install the 5th-6th synchronizer hub assembly using Tool as shown.

CAUTION:

Align the grooves of the 5th-6th shifting insert and 5th-6th baulk ring.

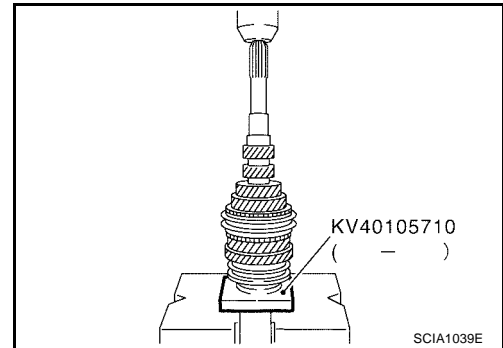

14. Install the needle bearing, 6th input gear and then 6th bushing using Tool as shown.

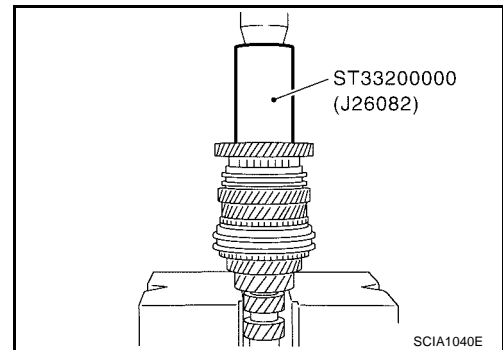

15. Install the snap ring onto the input shaft, and measure to check that end play (gap between snap ring and groove) of the 6th bushing is within specification.

End play standard value : 0 - 0.1 mm (0 - 0.004 in)

- If the measurement is outside the standard value, select the appropriate size snap ring.

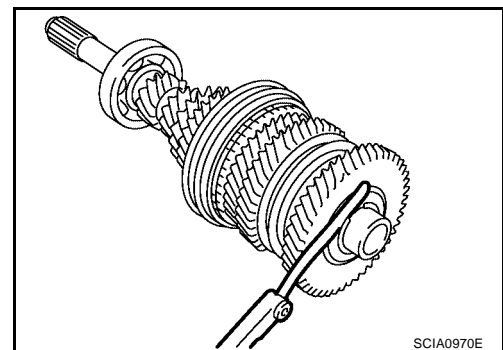

Snap Rings

Thickness	Part number	Thickness	Part number
1.76 mm (0.0693 in)	32204 8H511	2.01 mm (0.0791 in)	32204 8H516
1.81 mm (0.0713 in)	32204 8H512	2.06 mm (0.0811 in)	32204 8H517
1.86 mm (0.0732 in)	32204 8H513	2.11 mm (0.0831 in)	32204 8H518
1.91 mm (0.0752 in)	32204 8H514	2.16 mm (0.0850 in)	32204 8H519
1.96 mm (0.0772 in)	32204 8H515	2.21 mm (0.0871 in)	32204 8H520

INPUT SHAFT AND GEARS

[RS6F51H]

16. Install the input shaft rear bearing using Tool as shown.

CAUTION:

Install input shaft bearing with its brown surface facing the input gear side.

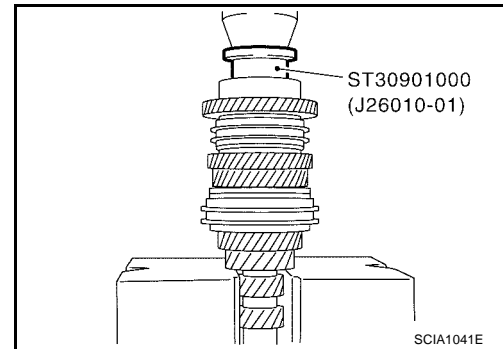

17. Install the input shaft front bearing using Tool as shown.

18. Install the oil channel onto the input shaft.

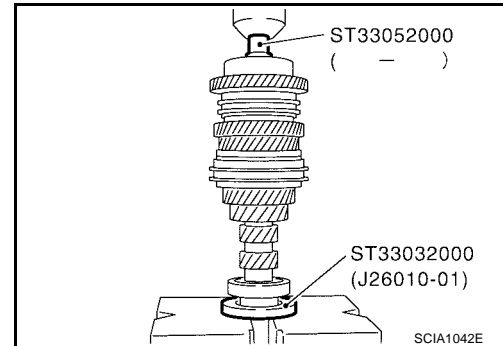

19. Check the end play of the 3rd, 4th, 5th and 6th input gears as shown.

End play standard value

3rd gear : 0.18 - 0.31 mm (0.0071 - 0.0122 in)

4th gear : 0.20 - 0.30 mm (0.0079 - 0.0118 in)

5th gear : 0.06 - 0.16 mm (0.0024 - 0.0063 in)

6th gear : 0.06 - 0.16 mm (0.0024 - 0.0063 in)

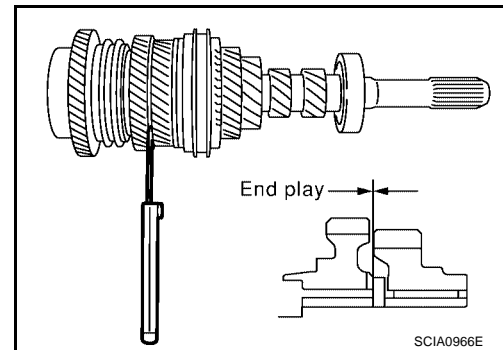

A
B
MT
D
E
F
G
H
I
J
K
L
M

MAINSHAFT AND GEARS

Disassembly and Assembly

DISASSEMBLY

1. Before disassembling, measure the end play of 1st and 2nd main gears as shown.

End play standard value

- 1st gear : 0.20 - 0.30 mm (0.0079 - 0.0118 in)**
- 2nd gear : 0.06 - 0.16 mm (0.0024 - 0.0063 in)**

CAUTION:

If the measurement is outside the standard value, disassemble to check the contact surfaces of gear, shaft, and hub. Adjust with the snap ring at assembly.

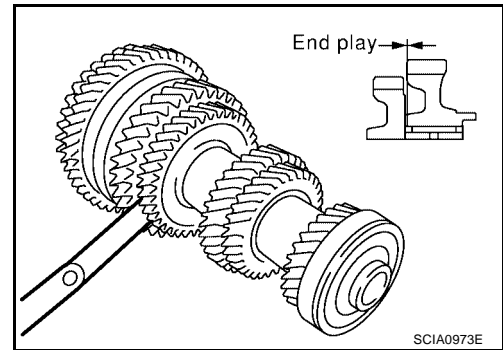

2. Remove the snap ring.
3. Remove the C-ring holder, and then mainshaft C-ring as shown.

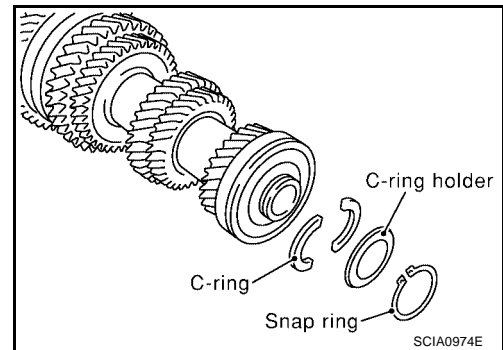

4. Remove the mainshaft rear bearing, adjust shim, and 6th main gear using Tool as shown.
5. Remove the 5th-6th mainshaft spacer.

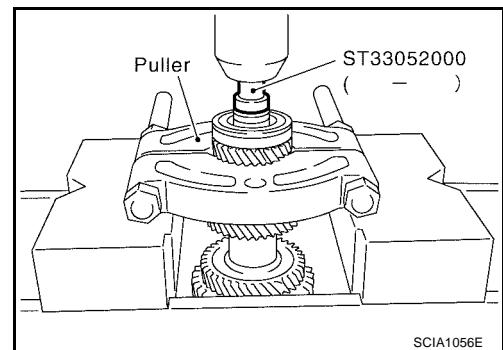

6. Remove the 4th main gear and 5th main gear simultaneously using Tool as shown.
7. Remove the adjusting shim.
8. Remove the 3rd-4th mainshaft spacer.

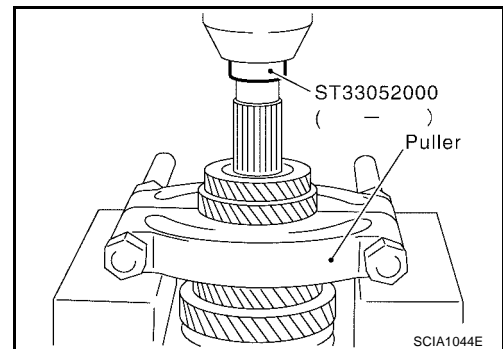

9. Remove the 3rd main gear, 2nd main gear, 2nd gear needle bearing, 2nd bushing, 1st-2nd synchronizer assembly, 1st main gear, reverse main gear, 1st gear needle bearing, and 1st bushing simultaneously using Tool as shown.

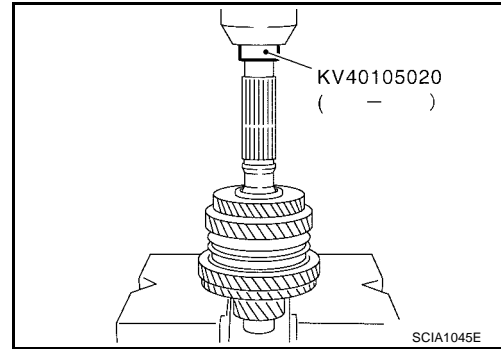

INSPECTION AFTER DISASSEMBLY

Mainshaft and Gears

Check the items listed as shown. If necessary, replace them with new ones.

- Damage, peeling, dent, uneven wear, bending, and other non-standard conditions of the mainshaft.
- Excessive wear, damage, peeling, and other non-standard conditions of the mainshaft gears.

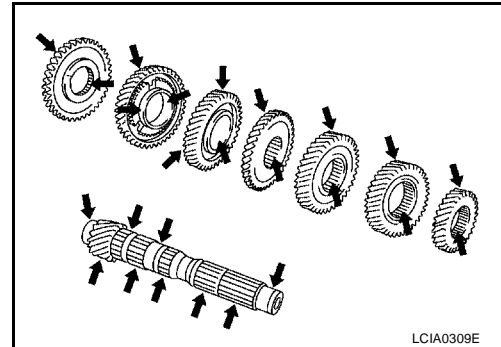

Synchronizer

Check the items listed as shown. If necessary, replace them with new ones.

- Damage, unusual wear on contact surfaces of coupling sleeve, synchronizer hub, and shifting insert.
- Coupling sleeve and synchronizer hub must move smoothly as shown.

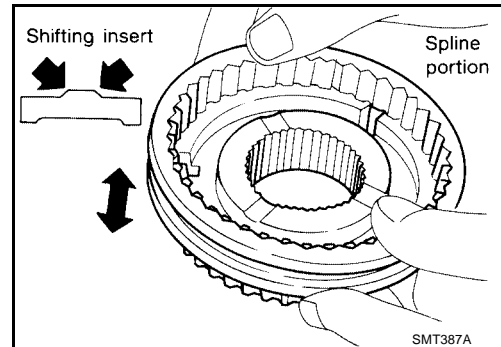

- If any cracks, damage, or excessive wear is found on the cam face of baulk ring or working face of the insert, replace it.

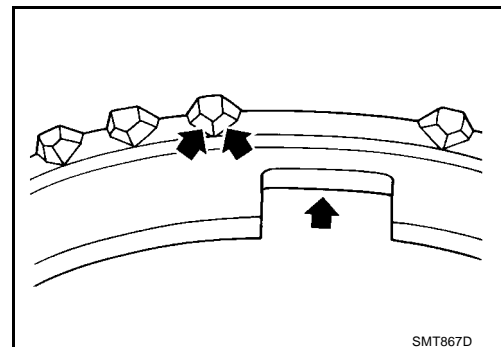

A
B
MT
D
E
F
G
H
I
J
K
L
M

Baulk Ring Clearance

Checking the double cone synchronizer (1st-2nd)

- Check the clearance of outer baulk ring, synchronizer cone, and inner baulk ring of 1st-2nd double cone synchronizer, using the following steps.

NOTE:

The mean value is the middle value of a set of measurements between the highest and lowest values. It is calculated by adding the highest and lowest measured value and dividing their sum by two: $[(\text{high value}) + (\text{low value})] / 2 = \text{mean value}$.

CAUTION:

Outer baulk ring, synchronizer cone, and inner baulk ring act as a set to control the clearances "A" and "B". If the measurement exceeds the service limit value, replace all of them as a set.

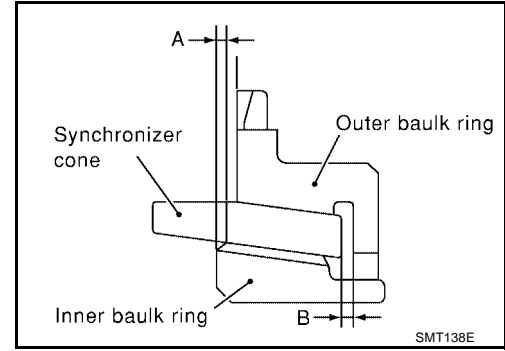

- Using a dial gauge and Tool, measure clearance "A" at two or more points diagonally opposite, and calculate mean value.

Clearance "A"

Standard : 0.6 - 0.8 mm (0.024 - 0.031 in)

Limit value : 0.2 mm (0.008 in) or less

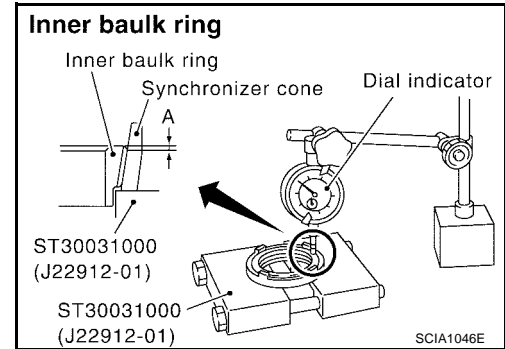

- Using a feeler gauge, measure clearance "B" at two or more points diagonally opposite, and calculate mean value as shown.

Clearance "B"

Standard : 0.6 - 1.1 mm (0.024 - 0.043 in)

Limit value : 0.2 mm (0.008 in) or less

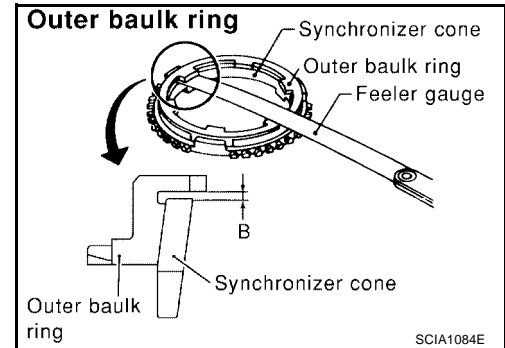

Bearing

Check the items below. If necessary, replace them with new ones.

- Damage and rough rotation of the bearing as shown.

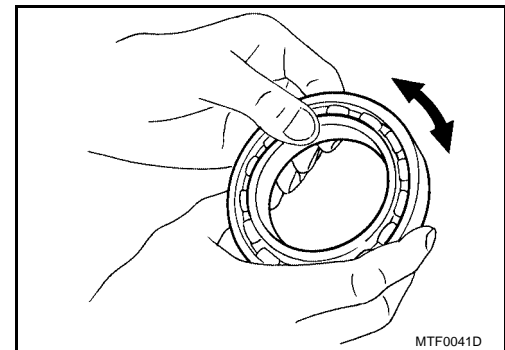

ASSEMBLY

1. Install the reverse main gear using Tool as shown.

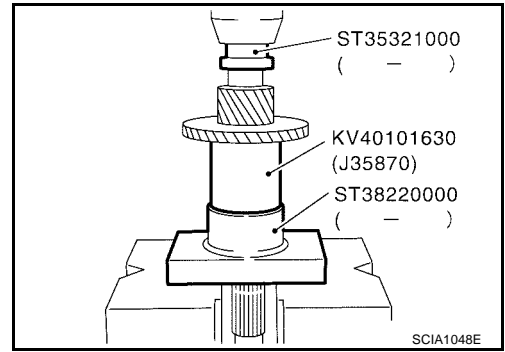

CAUTION:

Install with the orientation of reverse main gear as shown.

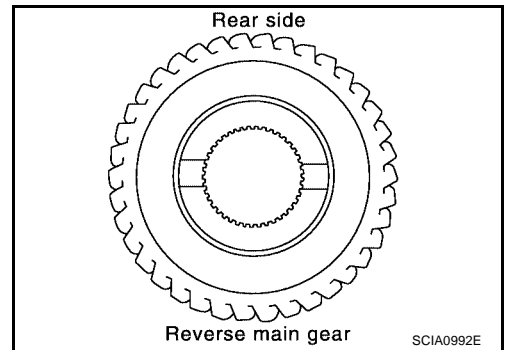

2. Install the 1st bushing using Tool as shown.
3. Install the needle bearing, and then the 1st main gear.

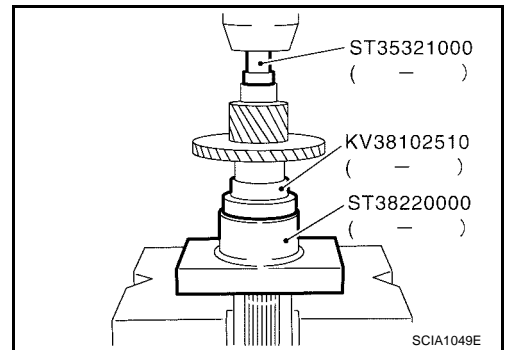

4. Install the spread spring, shifting insert, and a new 1st-2nd synchronizer hub onto the 1st-2nd coupling sleeve.

CAUTION:

- Install with the orientation of the new synchronizer hub as shown.
- Do not reuse 1st-2nd synchronizer hub

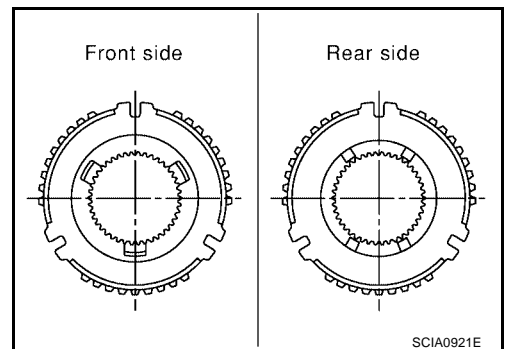

A
B
MT
D
E
F
G
H
I
J
K
L
M

MAINSHAFT AND GEARS

[RS6F51H]

- Install with the orientation of coupling sleeve as shown.

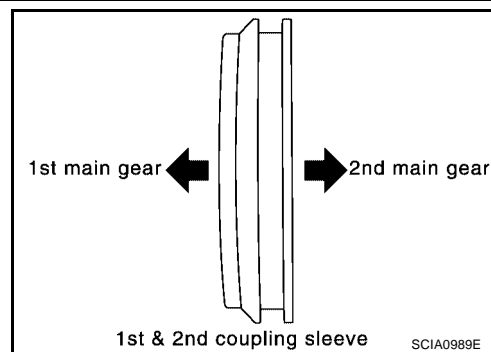

- Do not hook the ends of the two spread springs (front and back have two each) on the same shifting insert.

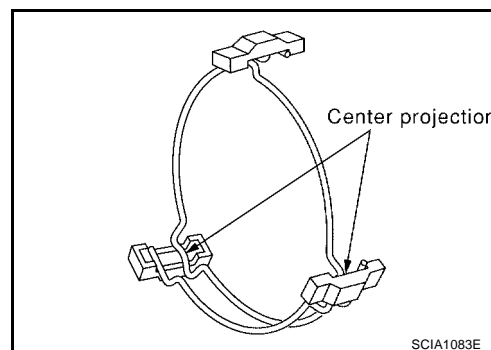

5. Install the 1st gear synchronizer assembly onto the mainshaft, and the synchronizer hub assembly onto the mainshaft using Tool as shown.

CAUTION:

- Outer baulk ring, synchronizer cone, and inner baulk ring on the 2nd gear-side must have been removed.
- Install the coupling sleeve with the proper orientation.

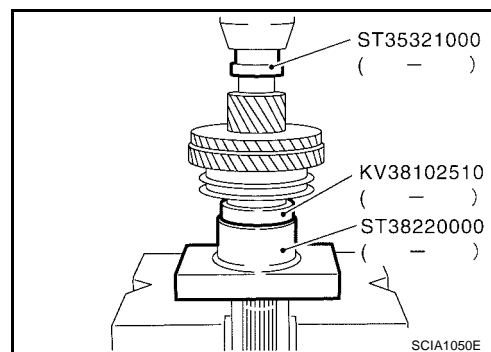

6. Install the 2nd bushing using Tool as shown.
7. Install the outer baulk ring, synchronizer cone, and inner baulk ring on 2nd gear-side.
8. Install the 2nd needle bearing and 2nd gear.

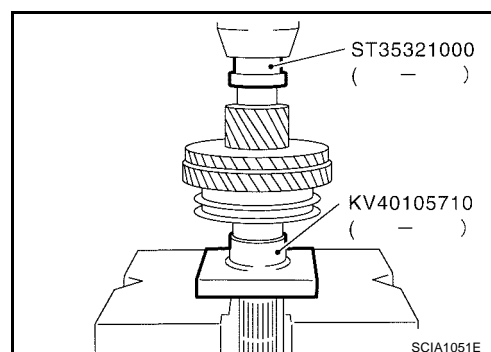

9. Install the 3rd main gear.

CAUTION:

Install the 3rd main gear with the orientation as shown.

10. Install the 3rd-4th mainshaft spacer.

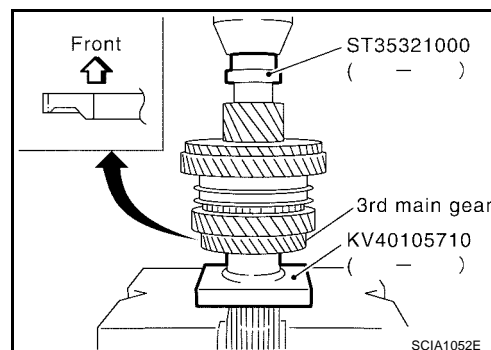

MAINSHAFT AND GEARS

[RS6F51H]

11. Measure the dimension "C1". Select a suitable adjusting shim so that the dimension "C1" satisfies the specified standard value, and install it onto the mainshaft.

Standard for dimension "C1" : 173.85 - 173.95 mm
(6.844 - 6.848 in)

CAUTION:

Only 1 adjusting shim can be selected.

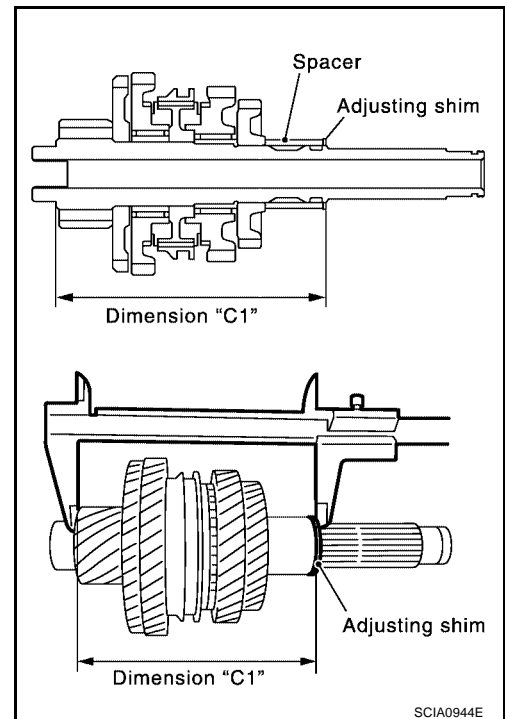

Adjusting Shim

Thickness	Part number	Thickness	Part number
0.52 mm (0.0205 in)	32238 8H500	0.84 mm (0.0331 in)	32238 8H504
0.60 mm (0.0236 in)	32238 8H501	0.92 mm (0.0362 in)	32238 8H505
0.68 mm (0.0268 in)	32238 8H502	1.00 mm (0.0394 in)	32238 8H506
0.76 mm (0.0299 in)	32238 8H503	1.08 mm (0.0425 in)	32238 8H507

12. Install the 4th main gear with the specified orientation as shown, using Tool as shown.

CAUTION:

Install the 4th main gear with the orientation as shown.

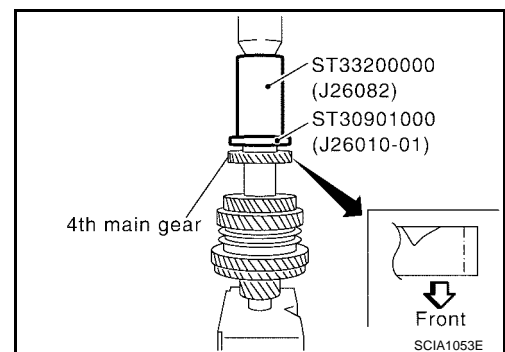

13. Install the 5th main gear with the specified orientation as shown, using Tool as shown.

CAUTION:

Install the 5th main gear with the orientation as shown.

14. Install the 5th-6th mainshaft spacer.

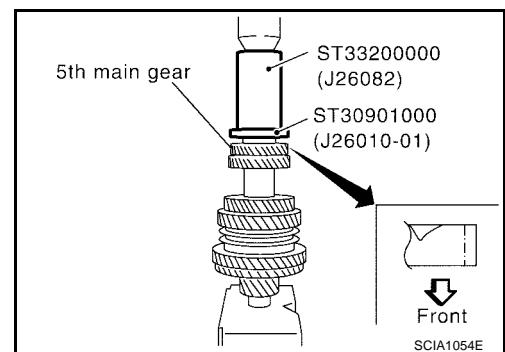

MAINSHAFT AND GEARS

[RS6F51H]

15. Install the 6th main gear using Tool as shown.

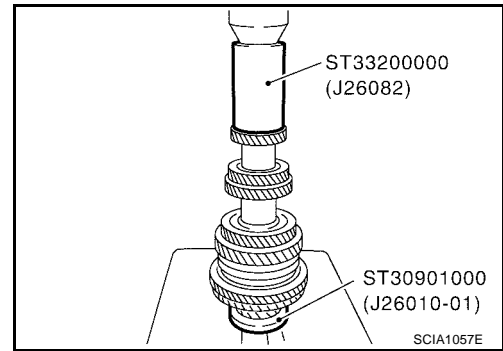

16. Select the 6th main adjusting shim and then install it onto the mainshaft.

- Calculate thickness “S” of 6th main adjusting shim by procedure below so that end play dimension between 6th main gear and mainshaft rear bearing becomes the dimension specified.

End play : 0 - 0.1 mm (0 - 0.004 in)

Dimension “S” = (“S₁” - “S₂”) + end play

“S” : Thickness of adjusting shim

“S₁” : Dimension from mainshaft standard face to mainshaft rear bearing press-fit end face

“S₂” : Dimension from mainshaft standard face to 6th main gear end face

CAUTION:

Only 1 adjusting shim can be selected.

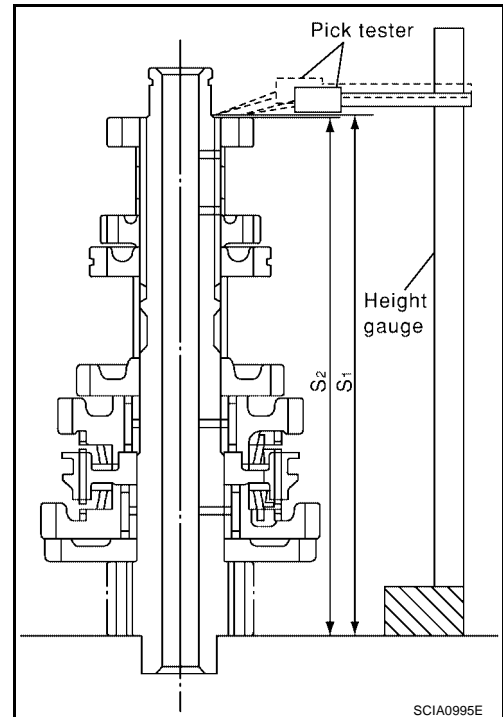

Adjusting Shim

Thickness	Part number	Thickness	Part number
0.88 mm (0.0346 in)	32237 8H560	1.20 mm (0.0472 in)	32237 8H564
0.96 mm (0.0378 in)	32237 8H561	1.28 mm (0.0504 in)	32237 8H565
1.04 mm (0.0409 in)	32237 8H562	1.36 mm (0.0535 in)	32237 8H566
1.12 mm (0.0441 in)	32237 8H563		

a. Using a height gauge, measure the dimension “S₁” and “S₂” as shown.

b. Install the selected 6th main adjusting shim to the mainshaft.

17. Install the mainshaft rear bearing using Tool as shown.

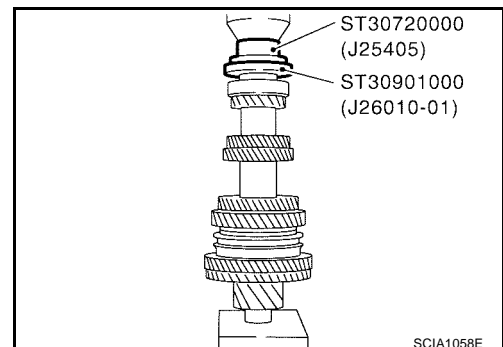

MAINSHAFT AND GEARS

[RS6F51H]

18. Install the C-ring onto the mainshaft, and check that the end play of mainshaft rear bearing meets specifications.

End play standard value : 0 - 0.06 mm (0 - 0.0024 in)

- If the measurement is outside the specified standard value, reselect a new C-ring.

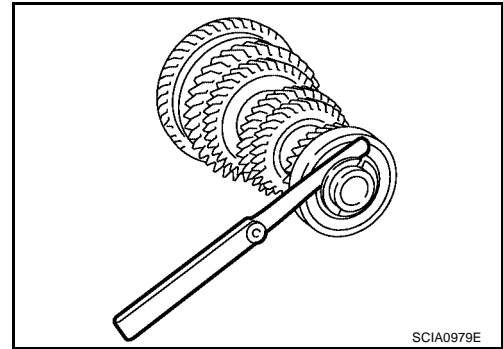

C-Ring

Thickness	Part number	Thickness	Part number
2.535 mm (0.0866 in)	32348 8H800	2.835 mm (0.1116 in)	32348 8H810
2.565 mm (0.1010 in)	32348 8H801	2.865 mm (0.1128 in)	32348 8H811
2.595 mm (0.1022 in)	32348 8H802	2.895 mm (0.1140 in)	32348 8H812
2.625 mm (0.1033 in)	32348 8H803	2.925 mm (0.1152 in)	32348 8H813
2.655 mm (0.1045 in)	32348 8H804	2.955 mm (0.1163 in)	32348 8H814
2.685 mm (0.1057 in)	32348 8H805	2.985 mm (0.1175 in)	32348 8H815
2.715 mm (0.1069 in)	32348 8H806	3.015 mm (0.1187 in)	32348 8H816
2.745 mm (0.1081 in)	32348 8H807	3.045 mm (0.1199 in)	32348 8H817
2.775 mm (0.1093 in)	32348 8H808	3.075 mm (0.1211 in)	32348 8H818
2.805 mm (0.1104 in)	32348 8H809		

19. Fit the C-ring holder, and install the snap ring as shown.

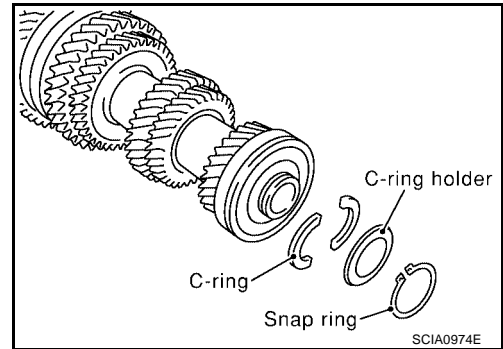

20. Check the end play of 1st and 2nd main gears as shown.

End play standard value

1st gear : 0.20 - 0.30 mm (0.0079 - 0.0118 in)

2nd gear : 0.06 - 0.16 mm (0.0024 - 0.0063 in)

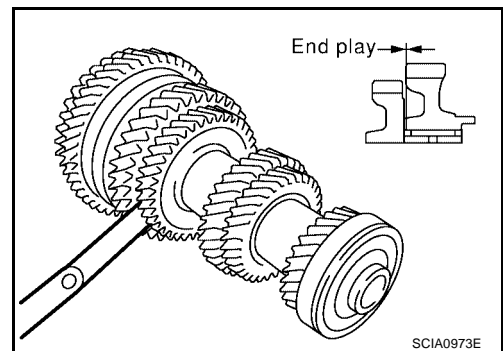

REVERSE IDLER SHAFT AND GEARS

Disassembly and Assembly DISASSEMBLY

1. Remove the reverse idler gear adjusting shim.
2. Remove the reverse idler gear (rear), reverse coupling sleeve and insert spring simultaneously.
3. Remove the reverse idler gear needle bearing.
4. Remove the thrust needle bearing.
5. Remove the reverse baulk ring.
6. Remove the reverse idler gear (front).
7. Remove the reverse idler gear needle bearing.
8. Remove the thrust needle bearing.
9. Pull off the locking pin from the reverse idler shaft.

INSPECTION AFTER DISASSEMBLY

Reverse Idler Shaft and Gears

Check the parts listed. If necessary, replace them with new ones.

- Damage, peeling, dent, uneven wear, bending, and other non-standard conditions of the reverse idler shaft.
- Excessive wear, damage, peeling, and other non-standard conditions of the reverse idler gears.

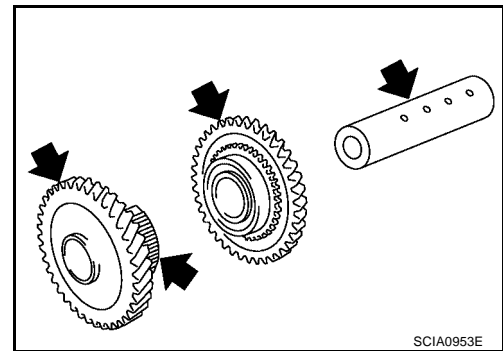

Synchronizer

Check parts listed. If necessary, replace them with new ones.

- Damage and unusual wear on contact surfaces of coupling sleeve, synchronizer hub, and insert spring.
- Coupling sleeve and synchronizer hub must move smoothly as shown.

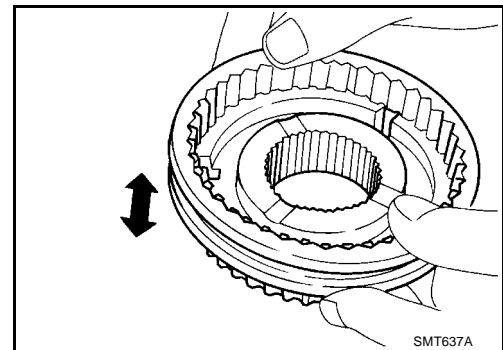

- If any crack, damage, or excessive wear is found on cam face of baulk ring or working face of insert, replace it.

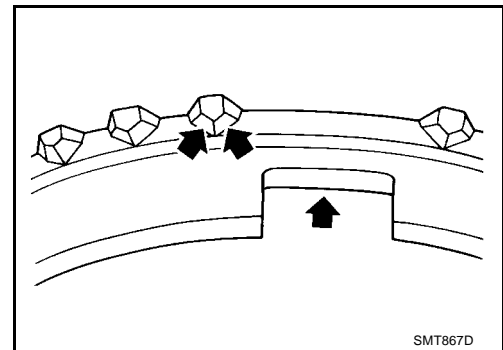

Baulk ring clearance

- Press the baulk ring against the cone, and measure the clearance between the baulk ring and cone as shown. If the measurement is below the specified limit, replace it with a new one.

Baulk ring to gear clearance

Standard : 0.95 - 1.4 mm (0.0374 - 0.055 in)

Limit value : 0.7 mm (0.028 in)

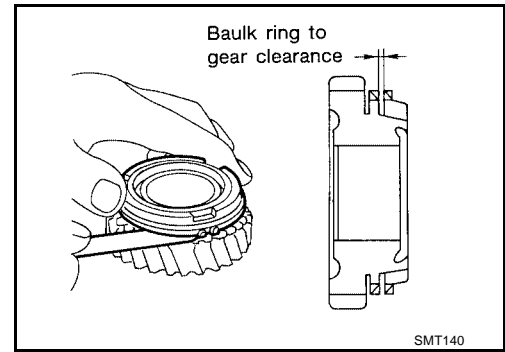

Bearing

Check the parts listed. If necessary, replace them with new ones.

- Damage and rough rotation of the bearing.

ASSEMBLY

Assembly is in the reverse order of disassembly.

CAUTION:

- Install the insert spring with the orientation as shown.

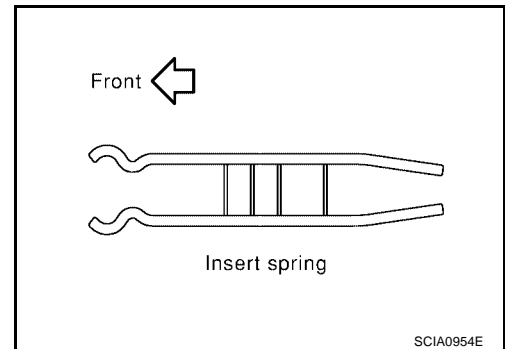

A
B
MT
D
E
F
G
H
I
J
K
L
M

FINAL DRIVE

PF3:38411

Disassembly and Assembly

ECS005VK

1. Remove the final gear bolts. Then, separate the final gear from the differential case.
2. Remove the speedometer drive gear.
3. Using a puller and Tool (drift), remove the differential side bearing (clutch housing side) as shown.

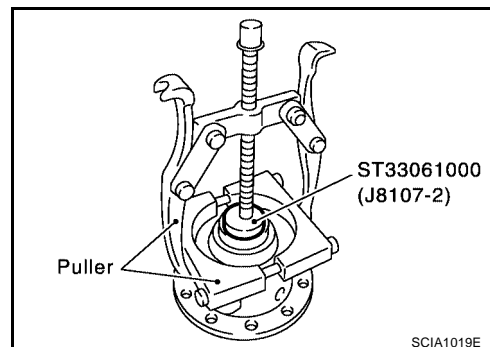

4. Using a puller and Tool (drift), remove the differential side bearing (transaxle case side) as shown.

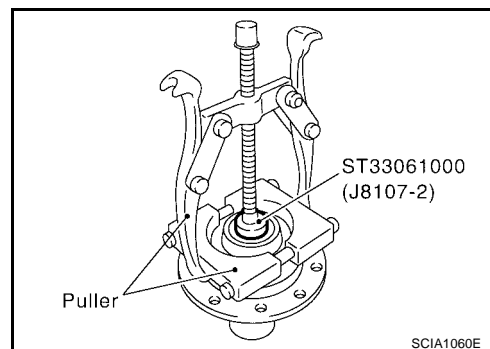

INSPECTION AFTER DISASSEMBLY

Bearing

- Check for bearing damage and rough rotation as shown. If necessary, replace with a new one.

CAUTION:

When replacing the tapered roller bearing, replace the outer and inner races as a set.

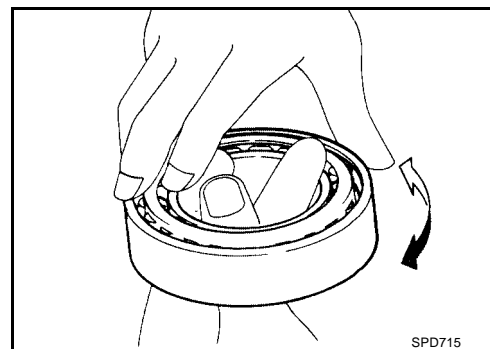

ASSEMBLY

1. Using Tool (drift), install the differential side bearing (transaxle case side) as shown.

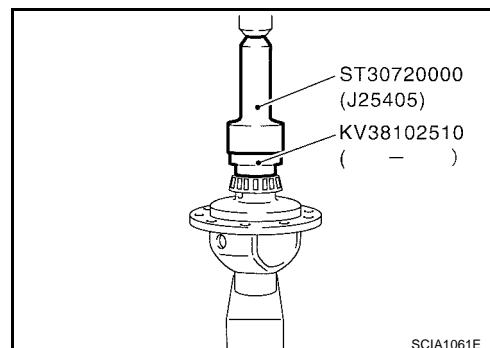

FINAL DRIVE

[RS6F51H]

- Align and install the speedometer drive gear onto the differential case as shown.

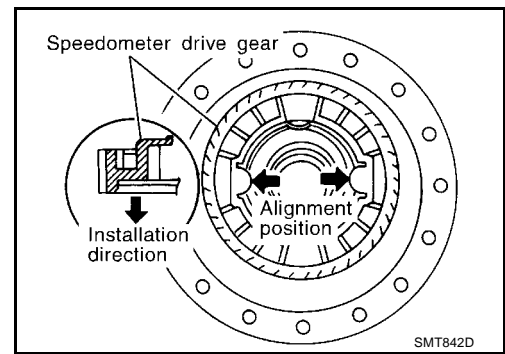

- Using Tool (drift), install the differential side bearing (clutch housing side) as shown.

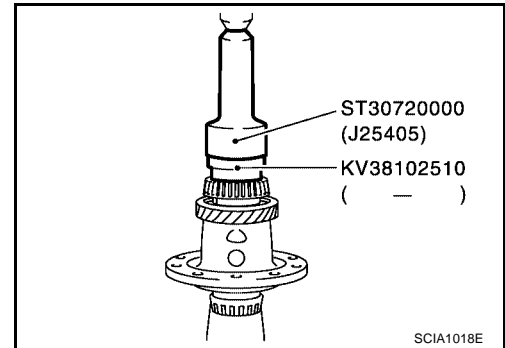

- Install the final gear into the differential case, and tighten the final gear bolts to specification.

Final gear bolts : Refer to [MT-149, "FINAL DRIVE COMPONENTS"](#) .

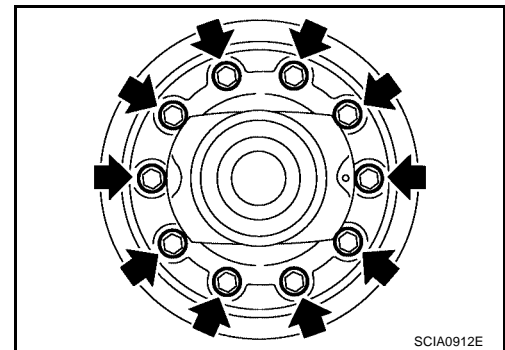

A
B
MT
D
E
F
G
H
I
J
K
L
M

SHIFT CONTROL

Inspection

- Check the contact surfaces and sliding area for wear, damage, or bending as shown. If necessary, replace the parts.

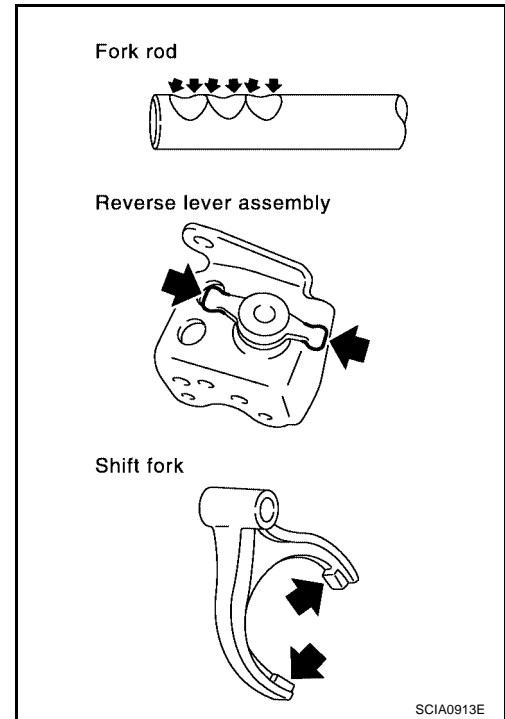

SHIFT FORK

- Check if the width of the shift fork hook (sliding area with coupling sleeve) is within specification, as shown.

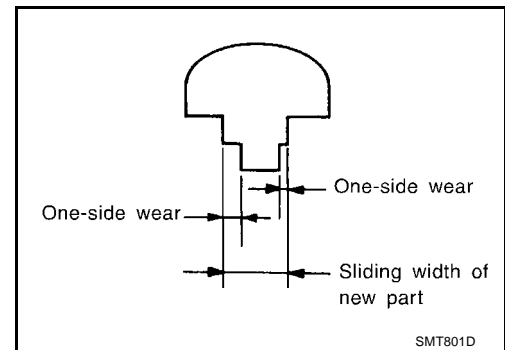

Shift Fork

Item	One-side wear specification	Sliding width of new part
1st & 2nd	0.2 mm (0.008 in)	7.80 - 7.93 mm (0.3071 - 0.3122 in)
3rd & 4th	0.2 mm (0.008 in)	7.80 - 7.93 mm (0.3071 - 0.3122 in)
5th & 6th	0.2 mm (0.008 in)	6.10 - 6.23 mm (0.2402 - 0.2453 in)
Reverse	0.2 mm (0.008 in)	12.80 - 12.93 mm (0.5039 - 0.5091 in)

SERVICE DATA AND SPECIFICATIONS (SDS)

[RS6F51H]

SERVICE DATA AND SPECIFICATIONS (SDS)

PFP:00030

General Specifications TRANSAXLE

ECS005VM

Engine		QR25DE	
Transaxle model		RS6F51H	
Model code number		8U376	
Number of speed		6	
Synchromesh type		Warner	
Shift pattern		<p style="text-align: center;">SCIA0955E</p>	
Gear ratio	1st	3.153	
	2nd	1.944	
	3rd	1.392	
	4th	1.055	
	5th	0.809	
	6th	0.673	
	Reverse	3.002	
Number of teeth	Input gear	1st	13
		2nd	18
		3rd	28
		4th	36
		5th	42
		6th	46
		Reverse	13
	Main gear	1st	41
		2nd	35
		3rd	39
		4th	38
		5th	34
		6th	29
		Reverse	38
Reverse idler gear	Front	37	
	Rear	38	
Oil capacity ℓ (qt)		2.3 (2 3/8)	
Remarks	Reverse synchronizer	Installed	
	Double baulk ring type synchronizer	1st & 2rd synchronizer	

SERVICE DATA AND SPECIFICATIONS (SDS)

[RS6F51H]

FINAL GEAR

Engine	QR25DE	
Transaxle model	RS6F51H	
Model code number	8U376	
Final gear ratio	4.133	
Number of teeth	Final gear/Pinion	62/15
	Side gear/Pinion mate gear	—

Gear End Play

ECS005VN

Unit: mm (in)

Gear	End play
1st main gear	0.20 - 0.30 (0.0079 - 0.0118)
2nd main gear	0.06 - 0.16 (0.0024 - 0.0063)
3rd input gear	0.18 - 0.31 (0.0071 - 0.0122)
4th input gear	0.20 - 0.30 (0.0079 - 0.0118)
5th input gear	0.06 - 0.16 (0.0024 - 0.0063)
6th input gear	0.06 - 0.16 (0.0024 - 0.0063)

Clearance Between Baulk Ring and Gear 3RD, 4TH, 5TH, 6TH & REVERSE BAULK RING

ECS005VO

Unit: mm (in)

Standard	Wear limit
3rd	0.9 - 1.45 (0.035 - 0.0571)
4th	0.9 - 1.45 (0.035 - 0.0571)
5th	0.95 - 1.4 (0.0374 - 0.055)
6th	0.95 - 1.4 (0.0374 - 0.055)
Reverse	0.95 - 1.4 (0.0374 - 0.055)

1ST AND 2ND DOUBLE BAULK RING

Unit: mm (in)

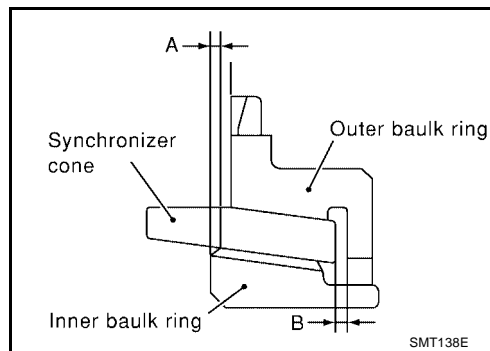

Dimension	Standard	Wear limit
A	0.6 - 0.8 (0.024 - 0.031)	0.2 (0.008)
B	0.6 - 1.1 (0.024 - 0.043)	0.2 (0.008)

SERVICE DATA AND SPECIFICATIONS (SDS)

[RS6F51H]

Available Snap Rings 6TH BUSHING

ECS005VP

End play		0 - 0.1 mm (0 - 0.004 in)	
Thickness mm (in)	Part number*	Thickness mm (in)	Part number*
1.76 (0.0693)	32204 8H511	2.01 (0.0791)	32204 8H516
1.81 (0.0713)	32204 8H512	2.06 (0.0811)	32204 8H517
1.86 (0.0732)	32204 8H513	2.11 (0.0831)	32204 8H518
1.91 (0.0752)	32204 8H514	2.16 (0.0850)	32204 8H519
1.96 (0.0772)	32204 8H515	2.21 (0.0871)	32204 8H520

*: Always check with the Parts Department for the latest parts information.

Available C-rings MAINSHAFT C-RING

ECS005VQ

End play		0 - 0.06 mm (0 - 0.0024 in)	
Thickness mm (in)	Part number*	Thickness mm (in)	Part number*
2.535 (0.0866)	32348 8H800	2.835 (0.1116)	32348 8H810
2.565 (0.1010)	32348 8H801	2.865 (0.1128)	32348 8H811
2.595 (0.1022)	32348 8H802	2.895 (0.1140)	32348 8H812
2.625 (0.1033)	32348 8H803	2.925 (0.1152)	32348 8H813
2.655 (0.1045)	32348 8H804	2.955 (0.1163)	32348 8H814
2.685 (0.1057)	32348 8H805	2.985 (0.1175)	32348 8H815
2.715 (0.1069)	32348 8H806	3.015 (0.1187)	32348 8H816
2.745 (0.1081)	32348 8H807	3.045 (0.1199)	32348 8H817
2.775 (0.1093)	32348 8H808	3.075 (0.1211)	32348 8H818
2.805 (0.1104)	32348 8H809		

*: Always check with the Parts Department for the latest parts information.

Available Thrust Washers INPUT SHAFT THRUST WASHER

ECS005VR

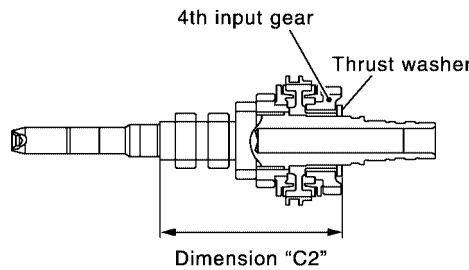

SCIA1008E

Standard length "C2"		154.7 - 154.8 mm (6.091 - 6.094in)	
Thickness mm (in)	Part number*	Thickness mm (in)	Part number*
3.84 (0.1512)	32347 8H500	4.02 (0.1583)	32347 8H503
3.90 (0.1535)	32347 8H501	4.08 (0.1606)	32347 8H504
3.96 (0.1559)	32347 8H502	4.14 (0.1630)	32347 8H505

*: Always check with the Parts Department for the latest parts information.

SERVICE DATA AND SPECIFICATIONS (SDS)

[RS6F51H]

ECS005VS

Available Adjusting Shims MAINSHAFT ADJUSTING SHIM

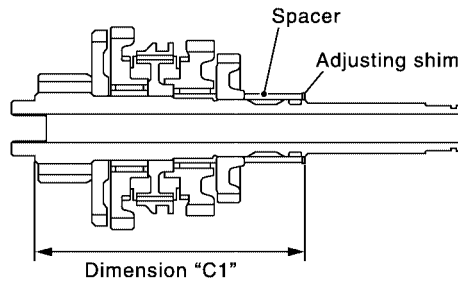

SCIA1009E

Standard length "C1"		173.85 - 173.95 mm (6.844 - 6.848in)	
Thickness mm (in)	Part number*	Thickness mm (in)	Part number*
0.52 (0.0205)	32238 8H500	0.84 (0.0331)	32238 8H504
0.60 (0.0236)	32238 8H501	0.92 (0.0362)	32238 8H505
0.68 (0.0268)	32238 8H502	1.00 (0.0394)	32238 8H506
0.76 (0.0299)	32238 8H503	1.08 (0.0425)	32238 8H507

*: Always check with the Parts Department for the latest parts information.

INPUT SHAFT REAR BEARING ADJUSTING SHIM

End play			0 - 0.06 mm (0 - 0.0024 in)		
Thickness mm (in)	Part number*	Thickness mm (in)	Part number*	Thickness mm (in)	Part number*
0.40 (0.0157)	32225 8H500	0.88 (0.0346)	32225 8H512	1.36 (0.0520)	32225 8H524
0.44 (0.0173)	32225 8H501	0.92 (0.0362)	32225 8H513	1.40 (0.0551)	32225 8H560
0.48 (0.0189)	32225 8H502	0.96 (0.0378)	32225 8H514	1.44 (0.0567)	32225 8H561
0.52 (0.0205)	32225 8H503	1.00 (0.0396)	32225 8H515	1.48 (0.0583)	32225 8H562
0.56 (0.0220)	32225 8H504	1.04 (0.0409)	32225 8H516	1.52 (0.0598)	32225 8H563
0.60 (0.0236)	32225 8H505	1.08 (0.0425)	32225 8H517	1.56 (0.0614)	32225 8H564
0.64 (0.0252)	32225 8H506	1.12 (0.0441)	32225 8H518	1.60 (0.0630)	32225 8H565
6.68 (0.0268)	32225 8H507	1.16 (0.0457)	32225 8H519	1.64 (0.0646)	32225 8H566
0.72 (0.0283)	32225 8H508	1.20 (0.0472)	32225 8H520		
0.76 (0.0299)	32225 8H509	1.24 (0.0488)	32225 8H521		
0.80 (0.0315)	32225 8H510	1.28 (0.0504)	32225 8H522		
0.84 (0.0331)	32225 8H511	1.32 (0.0520)	32225 8H523		

*: Always check with the Parts Department for the latest parts information.

MAINSHAFT REAR BEARING ADJUSTING SHIM

End play		0 - 0.06 mm (0 - 0.0024 in)	
Thickness mm (in)	Part number*	Thickness mm (in)	Part number*
0.44 (0.0173)	32238 8H510	0.80 (0.0315)	32238 8H519
0.48 (0.0189)	32238 8H511	0.84 (0.0331)	32238 8H520
0.52 (0.0205)	32238 8H512	0.88 (0.0346)	32238 8H521
0.56 (0.0220)	32238 8H513	0.92 (0.0362)	32238 8H522
0.60 (0.0236)	32238 8H514	0.96 (0.0378)	32238 8H523
0.64 (0.0252)	32238 8H515	1.00 (0.0396)	32238 8H524
0.68 (0.0268)	32238 8H516	1.04 (0.0409)	32238 8H560
0.72 (0.0283)	32238 8H517	1.08 (0.0425)	32238 8H561
0.76 (0.0299)	32238 8H518		

*: Always check with the Parts Department for the latest parts information.

SERVICE DATA AND SPECIFICATIONS (SDS)

[RS6F51H]

REVERSE IDLER GEAR ADJUSTING SHIM

End play		0.04 - 0.14 mm (0.0016 - 0.0055 in)	
Thickness mm (in)	Part number*	Thickness mm (in)	Part number*
1.76 (0.0693)	32237 8H500	2.24 (0.0882)	32237 8H506
1.84 (0.0724)	32237 8H501	2.32 (0.0913)	32237 8H507
1.92 (0.0756)	32237 8H502	2.40 (0.0945)	32237 8H508
2.00 (0.0787)	32237 8H503	2.48 (0.0976)	32237 8H509
2.08 (0.0819)	32237 8H504	2.56 (0.1008)	32237 8H510
2.16 (0.0850)	32237 8H505	2.64 (0.1039)	32237 8H511

*: Always check with the Parts Department for the latest parts information.

6TH MAIN GEAR ADJUSTING SHIM

End play		0 - 0.1 mm (0 - 0.004 in)	
Thickness mm (in)	Part number*	Thickness mm (in)	Part number*
0.88 (0.0346)	32237 8H560	1.20 (0.0472)	32237 8H564
0.96 (0.0378)	32237 8H561	1.28 (0.0504)	32237 8H565
1.04 (0.0409)	32237 8H562	1.36 (0.0520)	32237 8H566
1.12 (0.0441)	32237 8H563		

*: Always check with the Parts Department for the latest parts information.

Available Shims

ECS005VT

— Differential Side Bearing Preload and Adjusting Shim —

BEARING PRELOAD

Differential side bearing preload: L*	0.15 - 0.21 mm (0.0059 - 0.0083)
---------------------------------------	----------------------------------

*: Install shims which are "deflection of differential case" + "L" in thickness.

DIFFERENTIAL SIDE BEARING ADJUSTING SHIM(S)

Thickness mm (in)	Part number*	Thickness mm (in)	Part number*
0.48 (0.0189)	31438 80X00	0.72 (0.0283)	31438 80X06
0.52 (0.0205)	31438 80X01	0.76 (0.0299)	31438 80X07
0.56 (0.0220)	31438 80X02	0.80 (0.0315)	31438 80X08
0.60 (0.0236)	31438 80X03	0.84 (0.0331)	31438 80X09
0.64 (0.0252)	31438 80X04	0.88 (0.0346)	31438 80X10
0.68 (0.0268)	31438 80X05	0.92 (0.0362)	31438 80X11

*: Always check with the Parts Department for the latest parts information.

